



Safety

# The Safety Handbook Experience - Systems - Products Machine safety offering from ABB Jokab Safety

Power and productivity  
for a better world™



# Productivity and safety go hand in hand

**Jokab Safety was acquired by ABB in march 2010. This gives us extra strength and a sales network in 120 countries. Our goal is to become even better at supporting you as a customer through cooperation within ABB Jokab Safety globally and locally.**

The fact that the leading power and automation technology company, ABB, and a leader in machine safety, Jokab Safety, are joining forces means a lot more than just a new organisational chart. ABB has a huge footprint in the industry - from power supply to the control of each individual motor - and has been delivering reliable solutions for decades that boost productivity in the industry. The acquisition of Jokab Safety now means the last building block is in place. We can now offer our customers tailored, turnkey solutions where machine safety is an integral and value-enhancing component.

Since its inception in 1988, Jokab Safety has been adhering to the business concept of developing innovative products and solutions for machine safety. The company has supplied everything from individual safety components to fully installed protection systems for entire production lines and works on a daily basis with the practical application of safety requirements in combination with production requirements. Jokab Safety is also represented on a variety of international standards committees concerned with the safety of machinery which means that we have now added this very valuable experience and knowledge to our offering. Similarly, ABB has always been a pioneer and a representative for its business areas and a powerful voice in professional organisations and committees. All in all, this creates an enormous bank of knowledge



and experience that we look forward to sharing with our customers.

Productivity and safety are not contradictory terms. On the contrary, safety solutions that are properly executed and adapted from the beginning will increase productivity. A partner that can deliver integrated and well thought out turnkey solutions enables a production-friendly safety environment. By building up and upgrading safety solutions in existing environments in a smart way, the mode of production will not need to be adapted to meet the requirements that safety sets. Instead, this allows a system that is manufacturing-friendly and that takes into account the business and its productivity objectives.

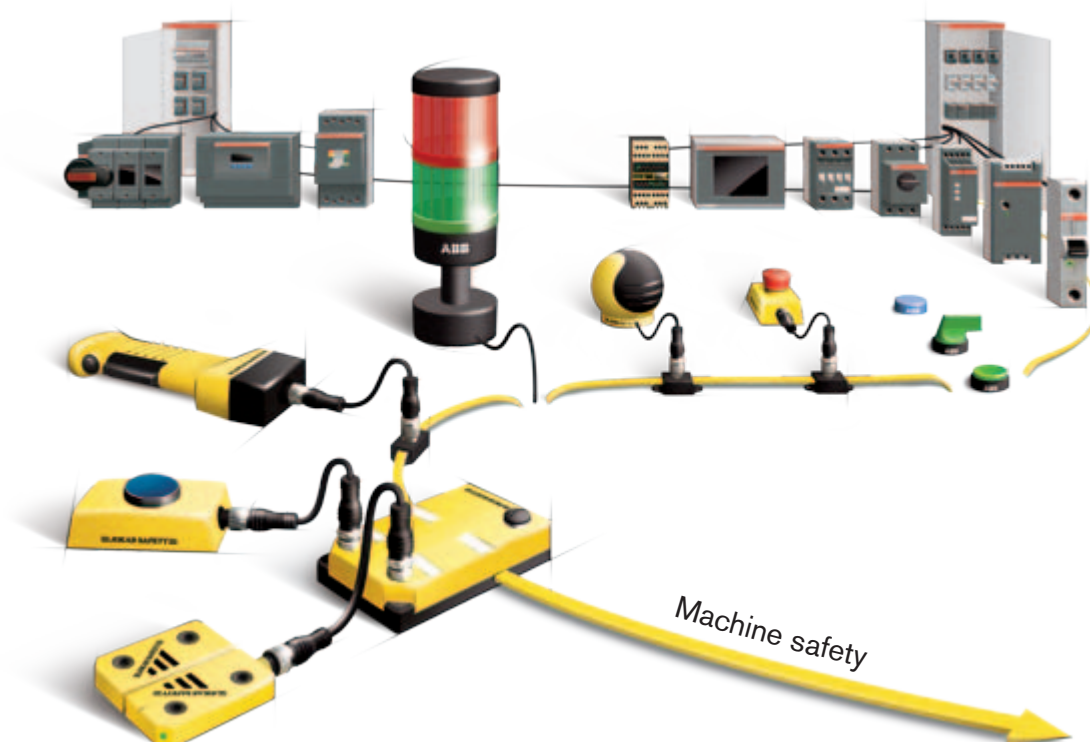



## **Introduction**

*We develop innovative products and solutions for machine safety, Safety history, Directives and Standards, Working method as specified in EN ISO 13849-1, What defines a safety function?, Applying EN 62061, A mechanical switch does not give a safe function! We train you on safety requirements*

1

## **Pluto Safety PLC**

*Pluto, Gateway, Profibus, DeviceNet, CANopen, Ethernet, Safe Encoder, IDFIX, program examples*

2

## **Pluto AS-i**

*Pluto AS-i, Urax, Flex*

3

## **Pluto Manager**

*Software for programming of Pluto*

4

## **Vital and Tina safety systems**

*Vital, Tina and Connection examples*

5

## **Safety relays**

*RT series, JSB series, Safety timers, Expansion relays, Connection examples*

6

## **Light curtains, Light grids, Light beams and Scanner**

*Focus, Spot, Look, Bjorn, Focus Wet, Blanking programmer, Connection examples*

7

## **Stop time measurement and machine diagnosis**

*Smart, Smart Manager*

8

## **Sensors/Switches**

*Eden, JSNY series, Magne, Dalton, Knox*

9

## **Control devices**

*3-position device JSHD4, Two-handed control unit Safeball*

10

## **Emergency stop devices**

*Inca, Smile, Smile Tina, Line emergency stop*

11

## **Contacts rails/Bumpers/Safety mats**

12

## **Fencing systems**

*Quick-Guard, Quick-Guard E, SafeCad, Roller doors*

13

## **EC Declaration of Conformity**

14

# We develop innovative products and solutions for machine safety

**We make it simple to build safety systems. Developing innovative products and solutions for machine safety has been our business idea since the company Jokab Safety, now ABB AB, was founded in Sweden in 1988. Our vision is to become “Your partner for machine safety – globally and locally”.**

**Many industries around the world, have discovered how much easier it has become to build protection and safety systems with our components and guidance.**

## Experience

We have great experience of practical application of safety requirements and standards from both authorities and production. We represent Sweden in standardisation organisations for machine safety and we work daily with the practical application of safety requirements in combination with production requirements. You can use our experience for training and advice.

## Systems

We deliver everything from a safety solution to complete safety systems for single machines or entire production lines. We combine production demands with safety demands for production-friendly solutions.

## Products

We market a complete range of safety products, which makes it easy to build safety systems. We develop these innovative products continuously, in cooperation with our customers. Our extensive program of products, safety solutions and our long experience in machine safety makes us a safe partner.



*Mats Linger and Torgny Olsson founded Jokab Safety AB in Sweden in 1988, together with Gunnar Widell, who remained in the company until 2001. In 2002 Jokab Safety North America was established, by means of a merger with the North American company NCC electronics, which had been founded in 1987 by Brian Sukarukoff and Scott Campbell (inset picture).*

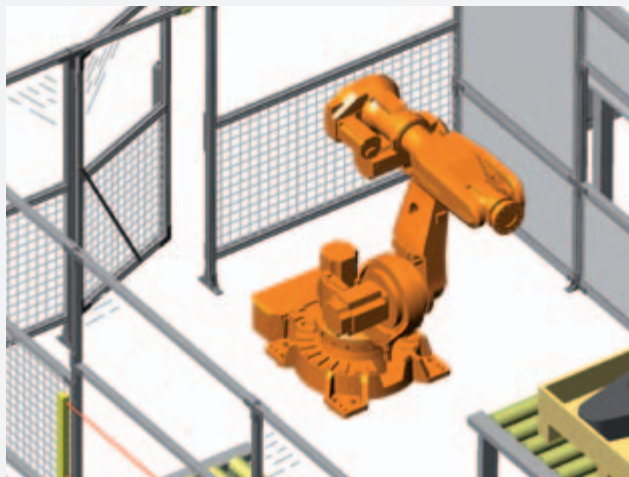

*Do you need to learn about the new safety requirements for robots? If so, please contact us.*

## Standards and regulations

### We help to develop standards

Directives and standards are very important to machinery and safety component manufacturers. We therefore participate in several international committees that develop standards, for among other things industrial robots, safety distances and control system safety features. This is experience that we absorb so that the standards will present requirements that benefit production efficiency allied to a high level of safety. We are happy to share our knowledge of standards with our customers.

# Our products revolutionise the market

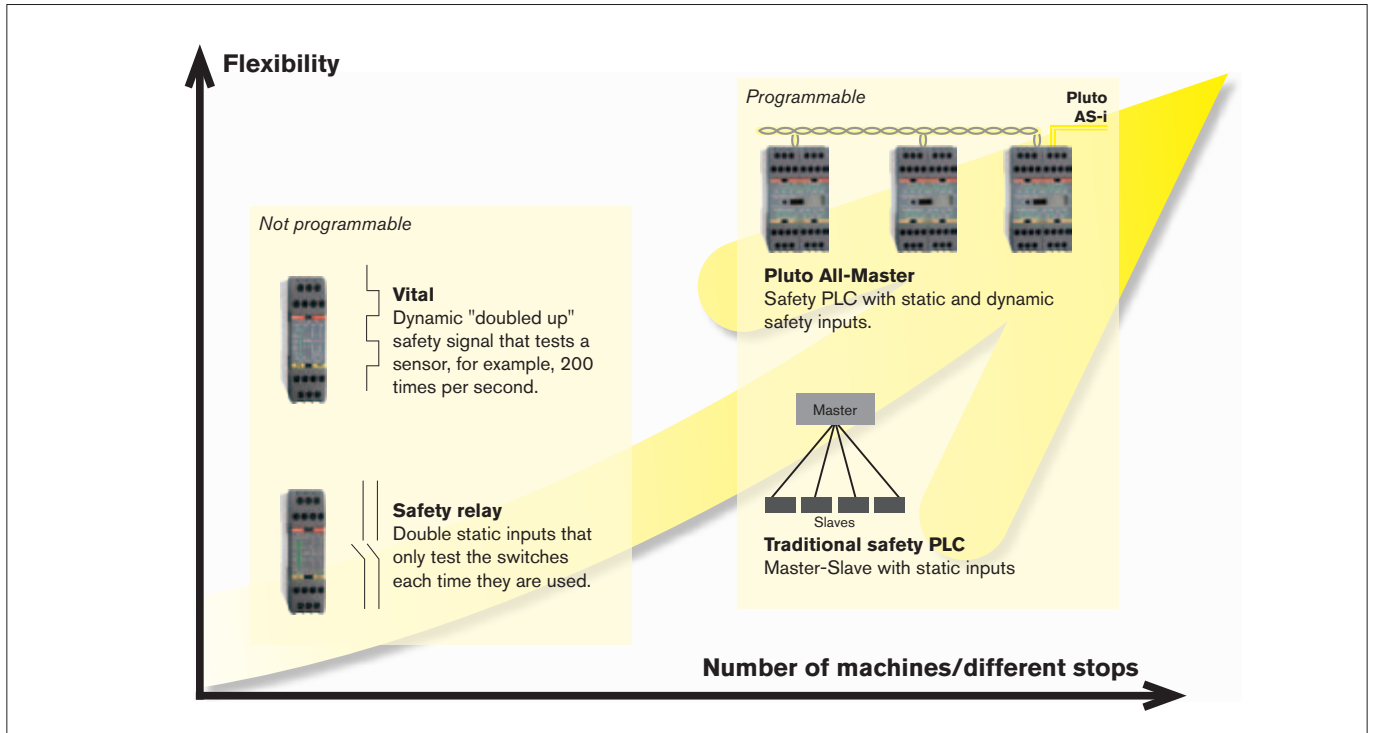

Our dynamic safety circuits and our comprehensive safety PLC are probably the most revolutionary ideas that have happened in the safety field in the control and supervision of protection, in many respects:

- They save on inputs: a dual safety circuit with one conductor instead of two. In addition, many protection devices can be connected to the same input while maintaining the highest level of safety.
- Reliability is better. Our electronic sensors have much longer lives than mechanical switches
- They are safer, since our dynamic safety sensors are checked 200 times per second. Traditional switches on a door can only be checked each time they are used, for example once per hour or even once a month.

- With the All-Master Safety PLC it is easy to connect and disconnect machinery from a safety viewpoint. Common emergency stop circuits and sensors can be created as soon as the buses are interconnected between our safety PLCs.

We are continuously designing safety systems for difficult environments and also to create new safety solutions where practical solutions are missing. New technical improvements give new possibilities and therefore we continuously develop new products.

## We train both machine builders and machine operators

### Do you construct machinery?

We can provide the training you need to construct machinery that meets the requirements. Example subjects:

- Practical implementation of the requirements in the new Machinery Directive 2006/42/EC, which is valid for machines that was delivered/put into service from the 29th of december 2009
- Risk analysis – in theory and practice
- Control systems safety, standards EN ISO 13849-1 and EN 62061

### Do you purchase and use machinery?

As a machinery user it is your responsibility to ensure that the correct requirements are complied with – regardless of whether your machinery is "new" or "old", i.e. CE-labelled or not. Unfortunately many have purchased CE-labelled machinery that does not meet the requirements. This must not be used. Having it brought into compliance by the supplier can take a long time and be expensive in terms of loss of production, etc. We can educate you on this and help you to set the right demands when buying new or even second-hand machinery.



# Safety history

## Developments of the 70's

Our background in safety started in the seventies when there was a significant focus on the safety of manually operated presses, the most dangerous machine in those days. The probability of losing a finger or hand while working with these machines was very high. New safety solutions for both safety devices as well as for the control systems for presses were developed and introduced on both old and new machines. We were directly involved in this work through the design of Two-Hand devices, control systems for presses, making safety inspections for the Health and Safety authorities and writing regulations for safety of these machines. This work provided an excellent base for our knowledge in machinery safety.

The numbers of accidents involving presses decreased significantly during these years however there is still room for new ideas to enable safety equipment become more practical and ergonomic.



*We protected people from losing fingers or/and hands in dangerous machines.*

## Developments of the 80's

During the eighties, industrial robots (Irb's) started to become commonplace in manufacturing industry. This meant that workers were outside of the dangerous areas during production but had at certain times to go inside the machine in order to e.g. adjust a product to the correct position, inspect the production cycle, troubleshoot and to programme the Irb. New risks were introduced and new safety methods required. It was for example hard to distinguish whether production machines had stopped safely or simply waiting for the next signal, such as a sensor giving a start signal while a product was being adjusted into the correct position. Mistakes in safety system design resulting in serious accidents were made, such as the omission of safety devices to stop the Irb, unreliable connection of safety devices and unreliable safety inputs on the Irb.

In the mid eighties the standards committee for safety in Industrial Robot Systems EN 775/ISO 775 was started. This was the first international standard for machine safety. In order to give the correct inputs to the standard, work around Irb's was closely studied in order to meet production integrated safety requirements. The introduction of a production oriented safety stop function was made, using for example, software to stop machines smoothly and then safety relays/contactors to disconnect the power to the machines actuators after the machine had stopped. This technique allows easy restart of production after a stop situation by the machine safeguards.

There were a lot of discussions as to whether one could have both safety and practical requirements in a standard, such as a safe stop function, which allowed an easy restart of the machine. Three-position enabling devices were also introduced for safety during programming, testing and trouble shooting of Irb's and other equipment. In the robot standard the three-position enabling function was first defined by only allowing for hazardous machinery functions in the mid switch position. Releasing or pressing the three-position push button in panic leading to a stop signal.



*Three-position enabling devices were also introduced for safety during programming.*

## Developments of the 90's

In Europe, during the nineties, the machinery directive was the start of a tremendous increase in co-operation across borders to get European standards for safety for machinery and safety devices. The experience from different European countries has led to a wide range of safety standards and this has made work in safety much easier. With the integration of Europe it is now only necessary for a safety company such as ourselves to get one approval for our components for all of Europe instead of one per country.



*European standards for safety for machinery and safety devices.*

## Developments 2000 -

Internationally the work on safety has now been intensified within ISO. The objective is to have the same structure of safety requirements and standards within ISO as within EN. ABB Jokab Safety is active both internationally and nationally in different standard working groups. The co-operation between countries is leading to better safety solutions, making it much easier to create safe working environments around the world.

## Jokab Safetys developments of the 80's



Jokab Safetys first safety relay



Jokab Safetys first steel fencing system

## Jokab Safetys developments of the 90's

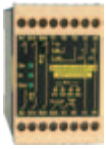

Timer reset and first light beam

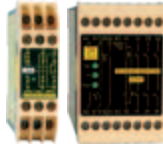
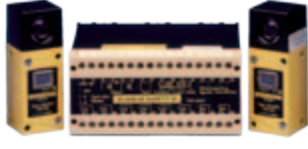

Smallest safety relays JSBT5 and JSBR4



Stop time measurement



Quick-Guard aluminium fencing system

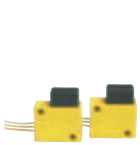

Three-position switch for robots



3-position devices



Safeball - ergonomic control device

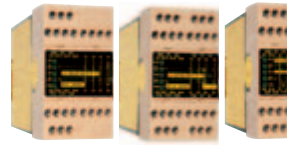

RT series universal relays



SafeCad for Quick-Guard

## Jokab Safetys developments 2000 -

### Pluto All-Master safety PLC

- Profibus DP
- DeviceNet
- CANopen
- Ethernet

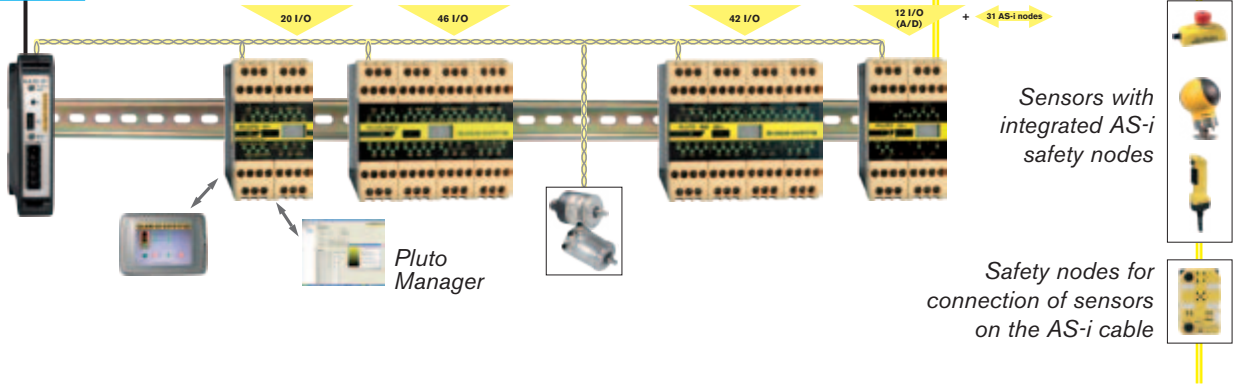

### Vital with dynamic safety circuits

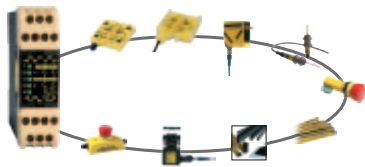

Vital 1

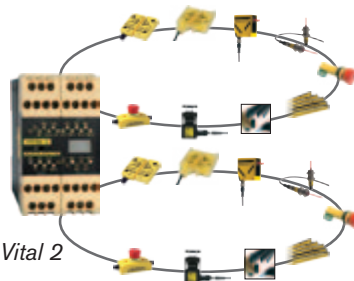

Vital 2

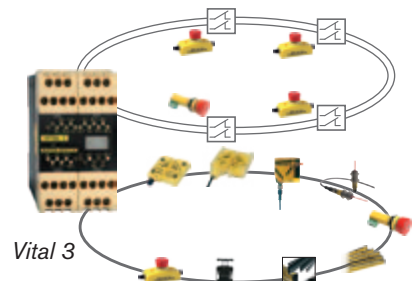

Vital 3

Non-contact sensor Eden, guard locks, Focus light beam, E-stops Inca and Smile, Smart for machine diagnosis and three-position device with hand detection

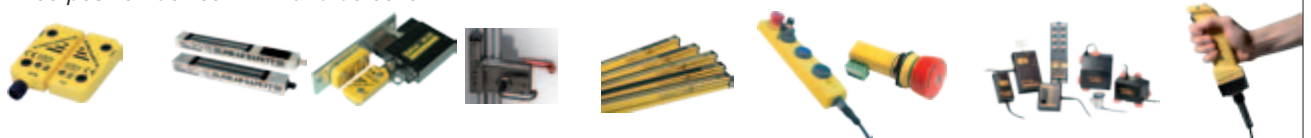

# Directives and Standards



**Directives and standards are of great importance for manufacturers of machines and safety components. EU Directives giving requirements for the minimum level of health and safety are mandatory for manufacturers to fulfil. In every member country the Directives are implemented in each countries legislation.**

**Machines which have been put on the market since december 29, 2009, must comply with the new Machinery Directive 2006/42/EC. Before that, the old Machinery Directive 98/37/EC was valid.**

The objectives of the Machinery Directive, 2006/42/EC, are to maintain, increase and equalise the safety level of machines within the members of the European Community. Based on this, the free movement of machines/products between the countries in this market can be achieved. The Machinery Directive is developed according to "The New Approach" which is based on the following principles

- The directives give the basic health and safety requirements, which are mandatory.
- Detailed solutions and technical specifications are found in harmonised standards.
- Standards are voluntary to apply, but products designed according to the harmonised standards will fulfil the basic safety requirements in the Machinery Directive.

## Harmonised standards

Harmonised standards give support on how to fulfil the requirements of the Machinery Directive. The relationship between the Machinery Directive and the harmonised standards is illustrated by the diagram below.

Within ISO (The International Organization for Standardization) work is also going on in order to harmonise the safety standards globally in parallel with the European standardisation work. One consequence of this is that many existing EN-standards will, when revised, change number. For example, EN 954-1 will when revised change number to EN ISO 13849-1. Due to the New Machinery Directive, all harmonised standards will be reviewed and revised to some extent.

ABB Jokab Safety takes an active part in the working groups both for the ISO and EN standards.

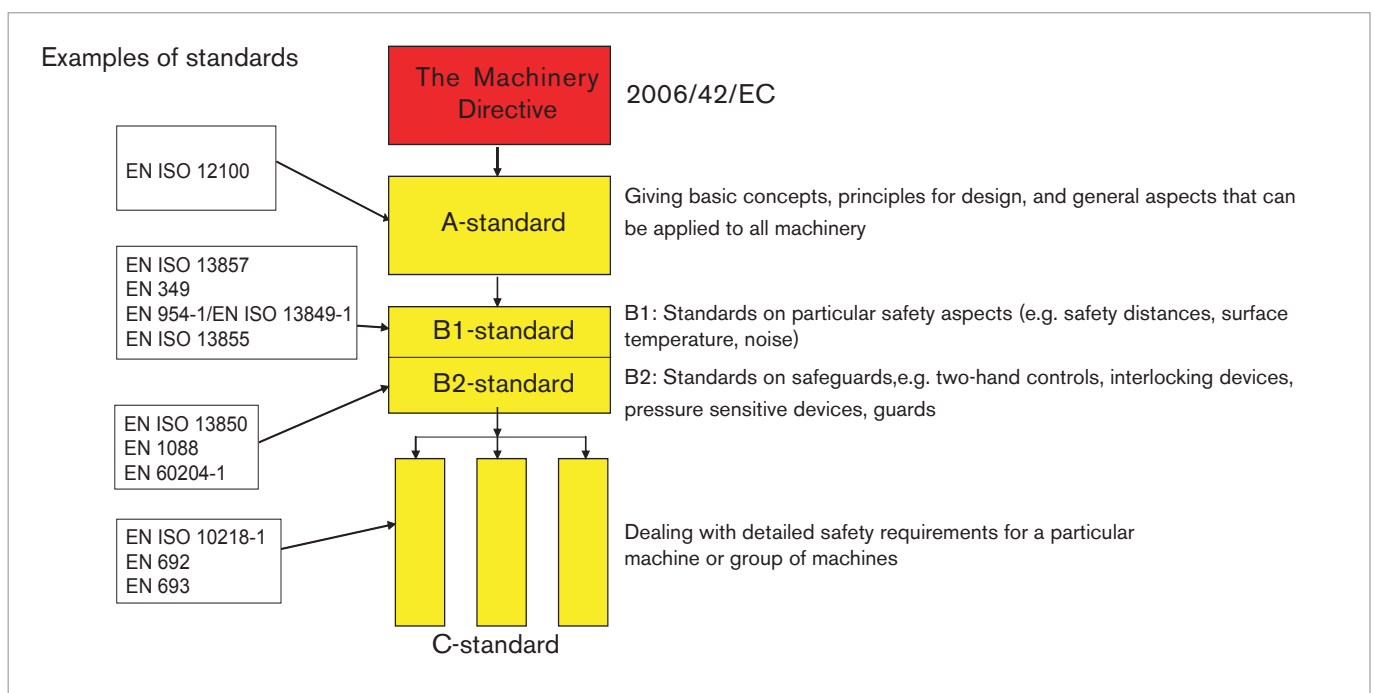



## The Machinery Directive; for machines and safety components

From 2006/42/EC

**1 §** This Directive applies to the following products:

- a) machinery;
- b) interchangeable equipment;
- c) safety components;
- d) lifting accessories;
- e) chains, ropes and webbing;
- f) removable mechanical transmission devices;
- g) partly completed machinery.

*The Machinery Directive gives the following definition:*

**a)** machinery' means:

- an assembly, fitted with or intended to be fitted with a drive system other than directly applied human or animal effort, consisting of linked parts or components, at least one of which moves, and which are joined together for a specific application,
- an assembly referred to in the first indent, missing only the components to connect it on site or to sources of energy and motion,
- an assembly referred to in the first and second indents, ready to be installed and able to function as it stands only if mounted on a means of transport, or installed in a building or a structure,
- assemblies of machinery referred to in the first, second and third indents or partly completed machinery referred to in point (g) which, in order to achieve the same end, are arranged and controlled so that they function as an integral whole,
- an assembly of linked parts or components, at least one of which moves and which are joined together, intended for lifting loads and whose only power source is directly applied human effort;

### CE-marking and Declaration of conformity

Machines manufactured or put on the market from december 29, 2009, shall be CE-marked and fulfil the requirements according to the European Machinery Directive 2006/42/EC. This is also valid for old machines (manufactured before 1 January 1995) if they are manufactured in a country outside the EEA and imported to be used in a country in the EEA.

For machines manufactured and/or released to the market between january 1, 1995, and december 28, 2009, the old Machinery Directive (98/37/EC) is valid.

**NOTE** The point in time when the Machinery Directive was implemented in each Member Country varies.

Machines have to be accompanied by a Declaration of Conformity (according to 2006/42/EC, Annex II 1.A) that states which directive and standards the machine fulfils. It also shows if the product has gone through EC Type Examination.

Safety components have to be accompanied with a Declaration of Conformity

## Requirements for the use of machinery

For a machine to be safe it is not enough that the manufacturer has been fulfilling all valid/necessary requirements. The user of the machine also has requirements to fulfil. For the use of machinery there is a Directive, 89/655/EEC (with amendment 96/63/EC and 2001/45/EC).

About CE-marked machinery the Directive gives the following requirement

### From 89/655/EEC (with amendment 96/63/EC and 2001/45/EC)

1. Without prejudice to Article 3, the employer must obtain and/or use:
- (a) work equipment which, if provided to workers in the undertaking and/or establishment for the first time after 31 December 1992, complies with:
    - (i) the provisions of any relevant Community directive which is applicable;
    - (ii) the minimum requirements laid down in Annex I, to the extent that no other Community directive is applicable or is so only partially;

This means that when repair/changes are made on the machine it shall still fulfil the requirements of the Machinery Directive. This doesn't have to mean that a new CE-marking is required. (Can be required if the changes are extensive)

**NOTE!** This means that the buyer of a machine also has to make sure that a new machine fulfills the requirements in the directives. If the machine does not fulfill the requirements the buyer is not allowed to use it.

### “Old” machines

For machines delivered or manufactured in the EEA before 1 January 1995 the following is valid.

(b) work equipment which, if already provided to workers in the undertaking and/or establishment by 31 December 1992, complies with the minimum requirements laid down in Annex I no later than four years after that date.

(c) without prejudice to point (a) (i), and notwithstanding point (a) (ii) and point (b), specific work equipment subject to the requirements of point 3 of Annex I, which, if already provided to workers in the undertaking and/or establishment by 5 December 1998, complies with the minimum requirements laid down in Annex I, no later than four years after that date.

Annex I contains minimum requirements for health and safety. There can also be additional national specific requirements for certain machines. **NB** The point in time when the Machinery Directive was implemented in each Member Country varies. Therefore it is necessary to check with the national authorities in ones own country, to find out what is considered as “old” and respectively “new” machines.

## "Old" machines

Machine that is put on the market or put into service before 1995 in the EEA.



**Council Directive 89/655/EEC (with amendment 96/63/EC and 2001/45/EC)** concerning the minimum safety and health requirements for the use of work equipment by workers at work.

Possible national legislation on specific machines

## "New" machines

1. Machine that is put on the market or put into service after 1/1 1995 in the EEA.

2. All machines that are imported to the EEA irrespective of date of origin.

**CE-marking + Declaration of conformity**



**Council Directive 89/655/EEC (with amendment 96/63/EC and 2001/45/EC)** concerning the minimum safety and health requirements for the use of work equipment by workers at work. N.B! Not annex 1, instead use applicable directives.

Low Voltage Directive 2006/95/EC

**The Machinery Directive 98/37/EC (Jan 1, 1995 - Dec 28, 2009) 2006/42/EC (from December 29, 2009)**

**EMC-directive 2004/108/EC**

Possibly more directives

## Risk assessment – an important tool both when constructing a new machine and when assessing risks on older machines

A well thought-out risk assessment supports manufacturers/users of machines to develop production friendly safety solutions. One result of this is that the safety components will not be a hindrance. This minimizes the risk of the safety system being defeated.

### New machines

The following requirement is given by the Machinery Directive

The manufacturer of machinery or his authorised representative must ensure that a risk assessment is carried out in order to determine the health and safety requirements which apply to the machinery. The machinery must then be designed and constructed taking into account the results of the risk assessment.

The standard EN ISO 12100 gives guidance on the information required to allow risk assessment to be carried out. The standard does not point out a specific method to be used. It is the responsibility of the manufacturer to select a suitable method.

### Machines in use

Risk assessment must be carried out on all machines that are in use; CE-marked as well as not CE-marked.

To fulfil the requirements from Directive 89/655/EEC (concerning the minimum safety and health requirements for the use of work equipment by workers at work) risk assessment have to be made.

### Documentation of risk assessment

The risk assessment shall be documented. In the assessment the actual risks shall be analysed as well as the level of seriousness.

## Protection or warning?

How is it possible to choose safety measures that are production friendly and in every way well balanced? The Machinery Directive gives an order of priority for the choice of appropriate methods to remove the risks. Here it is further developed in a five step method.

### Prioritize safety measures according to the five step method

1. Eliminate or reduce risks by design and construction
2. Move the work tasks outside the risk area
3. Use guards/safety devices
4. Develop safe working routines/information/education
5. Use warnings as pictograms, light, sound etc.

The further from middle of the circle, the greater the responsibility for the safety is put onto the user of the machine. If full protection is not effectively achieved in one step, one has to go to the next step and find complementary measures.

What is possible is dependant on the need for accessibility, the seriousness of the risk, appropriate safety measures etc.

### Example on prioritizing according to the 5-step-method

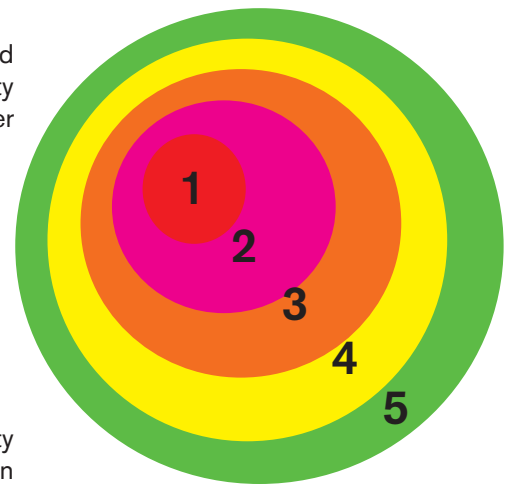

Priority	Example of hazard and safety measure taken
<b>1. Make machine safe by design and construction</b>	<i>Hazard:</i> Cuts and wounds from sharp edges and corners on machinery <i>Safety measure:</i> Round off sharp edges and corners.
<b>2. Move the work tasks outside the risk area</b>	<i>Hazard:</i> Crushing of fingers from machine movements during inspection of the production inside the risk area <i>Safety measure:</i> Installation of a camera.
<b>3. Use guard/safety devices</b>	<i>Hazard:</i> Crushing injuries because of unintended start during loading of work pieces in a mechanical press <i>Safety measure:</i> Install a light curtain to detect operator and provide safe stop of the machinery.
<b>4. Safe working routines/information</b>	<i>Hazard:</i> Crushing injuries because the machine can tip during installation and normal use. <i>Safety measure:</i> Make instructions on how the machine is to be installed to avoid the risks. This can include requirements on the type of fastening, ground, screw retention etc.
<b>5. Warnings</b>	<i>Hazard:</i> Burns because of hot surfaces in reach <i>Safety measure:</i> Warning signs

The possibilities will increase to achieve a well thought-through safety system if each risk is handled according to the described prioritizing.

### Combine the five step method with production friendly thinking. This can give you e.g.

- fast and easy restart of machines after a stop from a safety device
- enough space to safely program a robot
- places outside the risk area to observe the production
- electrically interlocked doors, instead of guards attached with screws, to be able to take the necessary measures for removing production disturbances
- a safety system that is practical for all types of work tasks, even when removing production disturbances



## Examples of regularly used EN/ISO standards

EN ISO 12100 (replaces EN ISO 12100-1/-2 and EN ISO 14121-1)	Safety of machinery - General principles for design - Risk assessment and risk reduction	Part 1: This standard defines basic terminology and methodology used in achieving safety of machinery. The provisions stated in this standard are intended for the designer. Part 2: This standard defines technical principles to help designers in achieving safety in the design of machinery.
EN ISO 13857	Safety of machinery - Safety distances to prevent hazard zones being reached by upper and lower limbs	This standard establishes values for safety distances to prevent danger zones being reached by the upper limbs. The distances apply when adequate safety can be achieved by distances alone.
EN 349 (ISO 13854)	Safety of machinery – Minimum gaps to avoid crushing of parts of the human body	The object of this standard is to enable the user (e.g. standard makers, designers of machinery) to avoid hazards from crushing zones. It specifies minimum gaps relative to parts of the human body and is applicable when adequate safety can be achieved by this method.
EN ISO 13850	Safety of machinery – Emergency stop – Principles for design	This standard specifies design principles for emergency stop equipment for machinery. No account is taken of the nature of the energy source.
EN 574	Safety of machinery – Two-hand control devices – Functional aspects – Principles for design	This standard specifies the safety requirements of a two-hand control device and its logic unit. The standard describes the main characteristics of two-hand control devices for the achievement of safety and sets out combinations of functional characteristics for three types.
EN 953	Safety of machinery – Guards – General requirements for the design and construction of fixed and movable guards	This standard specifies general requirements for the design and construction of guards provided primarily to protect persons from mechanical hazards.
EN ISO 13849-1 (replaces EN 954-1)	Safety of machinery – Safety related parts of control systems – Part 1: General principles for design	This standard provides safety requirements and guidance on the principles for the design (see 3.11 of EN 292-1:1991) of safety-related parts of control systems. For these parts it specifies categories and describes the characteristics of their safety functions. This includes programmable systems for all machinery and for related protective devices. It applies to all safety-related parts of control systems, regardless of the type of energy used, e.g. electrical, hydraulic, pneumatic, mechanical. It does not specify which safety functions and which categories shall be used in a particular case.
EN ISO 13849-2	Safety of machinery. Safety-related parts of control systems. Validation	This standard specifies the procedures and conditions to be followed for the validation by analysis and testing of: <ul style="list-style-type: none"> <li>• the safety functions provided, and</li> <li>• the category achieved of the safety-related parts of the control system in compliance with EN 954-1 (ISO 13849-1), using the design rationale provided by the designer.</li> </ul>
EN 62061	Safety of machinery. Functional safety of safety-related electrical, electronic and programmable electronic control systems	The standard defines the safety requirements and guiding principles for the design of safety-related electrical/electronic/programmable parts of a control system.
EN ISO 13855 (replaces EN 999)	Safety of machinery - Positioning of safeguards with respect to the approach speeds of parts of the human body	This standard provides parameters based on values for hand/arm and approach speeds and the methodology to determine the minimum distances from specific sensing or actuating devices of protective equipment to a danger zone.
EN 1088 and EN 1088/A1	Safety of machinery. Interlocking devices associated with guards. Principles for design and selection	This standard specifies principles for the design and selection - independent of the nature of the energy source - of interlocking devices associated with guards. It also provides requirements specifically intended for electrical interlocking devices. The standard covers the parts of guards which actuate interlocking devices.
EN 60204-1	Safety of machinery. Electrical equipment of machines. General requirements	This part of IEC 60204 applies to the application of electrical and electronic equipment and systems to machines not portable by hand while working, including a group of machines working together in a co-ordinated manner but excluding higher level systems aspects (i.e. communications between systems).

# New standards for safety in control systems

**Building a protection system that works in practice and provides sufficient safety requires expertise in several areas. The design of the safety functions in the protection system in order to ensure they provide sufficient reliability is a key ingredient. As help for this there is, for example, the EN ISO 13849-1 standard. The purpose of this text is to provide an introduction to the standard and its application in conjunction with our products.**

## Introducing the new standard

The generation change for standards on safety in control systems involving new concepts and calculations for machine builders and machine users. The EN 954-1 standard (categories) is being phased out and replaced by EN ISO 13849-1 (PL, Performance Level) and EN 62061 (SIL, Safety Integrity Level). Although the deadline for using EN 954-1 is set to 31/12/2011, it is beneficial to start applying the new standards as soon as possible as many new standards no longer refer to EN 954-1.

### PL or SIL? What should I use?

The standard you should use depends on the choice of technology, experience and customer requirements.

#### Choice of technology

- PL (Performance Level) is a technology-neutral concept that can be used for electrical, mechanical, pneumatic and hydraulic safety solutions.
- SIL (Safety Integrity Level) can, however, only be used for electrical, electronic or programmable safety solutions.

#### Experience

EN ISO 13849-1 uses categories from EN 954-1 for defining the system structure, and therefore the step to the new calculations is not so great if you have previous experience of the categories. EN 62061 defines the structures slightly differently.

#### Customer requirements

If the customer comes from an industry that is accustomed to using SIL (e.g. the process industry), requirements can also include safety functions for machine safety being SIL rated.

We notice that most of our customers prefer PL as it is technology-neutral and that they can use their previous knowledge in the categories. In this document we show some examples of how to build safety solutions in accordance with EN ISO 13849-1 and calculate the reliability of the safety functions to be used for a particular machine. The examples in this document are simplified in order to provide an understanding of the principles. The values used in the examples can change.

### What is PL (Performance Level)?

PL is a measure of the reliability of a safety function. PL is divided into five levels (a-e). PL e gives the best reliability and is equivalent to that required at the highest level of risk.

*To calculate which level the PL system achieves you need to know the following:*

- The system's structure (categories B, 1-4)
- The Mean Time To dangerous Failure of the component (MTTF<sub>d</sub>)
- The system's Diagnostic Coverage (DC)

*You will also need to:*

- protect the system against a failure that knocks out both channels (CCF)
- protect the system from systematic errors built into the design
- follow certain rules to ensure software can be developed and validated in the right way

The five PL-levels (a-e) correspond to certain ranges of PFH<sub>D</sub>-values (probability of dangerous failure per hour). These indicate how likely it is that a dangerous failure could occur over a period of one hour. In the calculation, it is beneficial to use PFH<sub>D</sub>-values directly as the PL is a simplification that does not provide equally accurate results.

### What is the easiest way of complying with the standard?

#### 1. Use pre-calculated components.

As far as it is possible, use the components with pre-calculated PL and PFH<sub>D</sub>-values. You then minimise the number of calculations to be performed. All ABB Jokab Safety products have pre-calculated PFH<sub>D</sub>-values.

#### 2. Use the calculation tool.

With the freeware application SISTEMA (see page 16) you avoid making calculations by hand. You also get help to structure your safety solutions and provide the necessary documentation.

#### 3. Use Pluto or Vital

Use the Pluto safety PLC or Vital safety controller. Not only is it easier to make calculations, but above all it is easier to ensure a higher level of safety.

# Working method as specified in EN ISO 13849-1

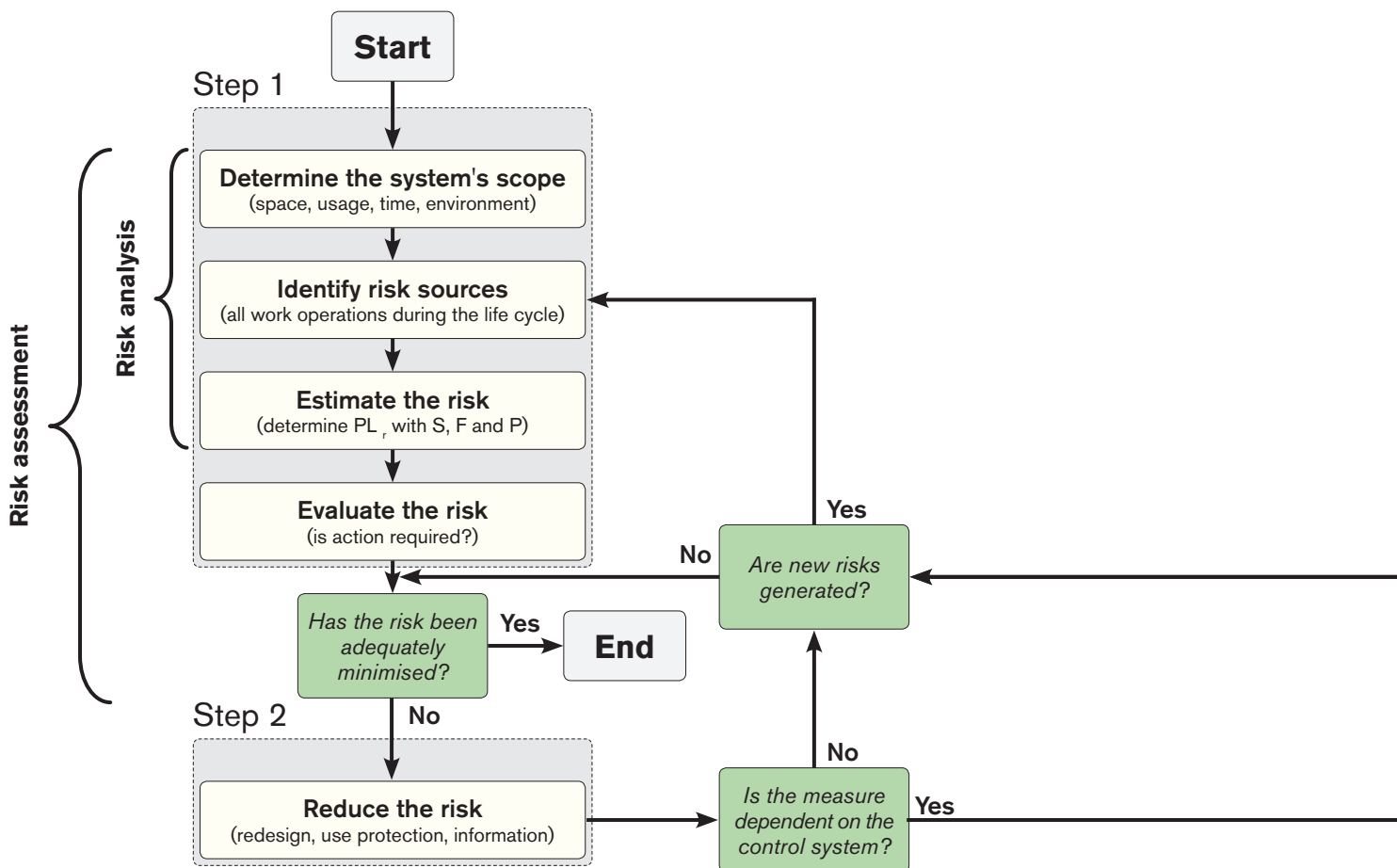

## Risk assessment and risk minimisation

According to the Machinery Directive, the machine builder (anyone who builds or modifies a machine) is required to perform a risk assessment for the machine design and also include an assessment of all the work operations that need to be performed. The EN ISO 12100 standard (combination of EN ISO 14121-1 and EN ISO 12100-1/-2) stipulates the requirements for the risk assessment of a machine. It is this that EN ISO 13849-1 is based on, and a completed risk assessment is a prerequisite for being able to work with the standard.

### Step 1 – Risk assessment

A risk assessment begins with determining the scope of the machine. This includes the space that the machine and its operators need for all of its intended applications, and all operational stages throughout the machine's life cycle.

All risk sources must then be identified for all work operations throughout the machine's life cycle.

A risk estimation is made for each risk source, i.e. indication of the degree of risk. According to EN ISO 13849-1 the risk is estimated using three factors: injury severity (S, severity),

frequency of exposure to the risk (F, frequency) and the possibility you have of avoiding or limiting the injury (P possibility). For each factor two options are given. Where the boundary between the two options lies is not specified in the standard, but the following are common interpretations:

- S1** *bruises, abrasions, puncture wounds and minor crushing injuries*
- S2** *skeletal injuries, amputations and death*
- F1** *less frequently than every two weeks*
- F2** *more often than every two weeks*
- P1** *slow machine movements, plenty of space, low power*
- P2** *quick machine movements, crowded, high power*

By setting S, F and P for the risk, you will get the PL, Performance Level (required) that is necessary for the risk source.

Finally, the risk assessment includes a risk evaluation where you determine if the risk needs to be reduced or if sufficient safety is ensured.



## Risk estimation

To calculate the performance level required ( $PL_r$ ).

### S Severity of injury

*S1 slight (usually transient injury)*

*S2 severe (usually permanent injury or death)*

### F Frequency and/or exposure time to risk source

*F1 rarely less often and/or short exposure time*

*F2 often to continuous and/or extended exposure time*

### P Possibility of avoiding the risk source or minimising the injury

*P1 possible under certain circumstances*

*P2 hardly possible*

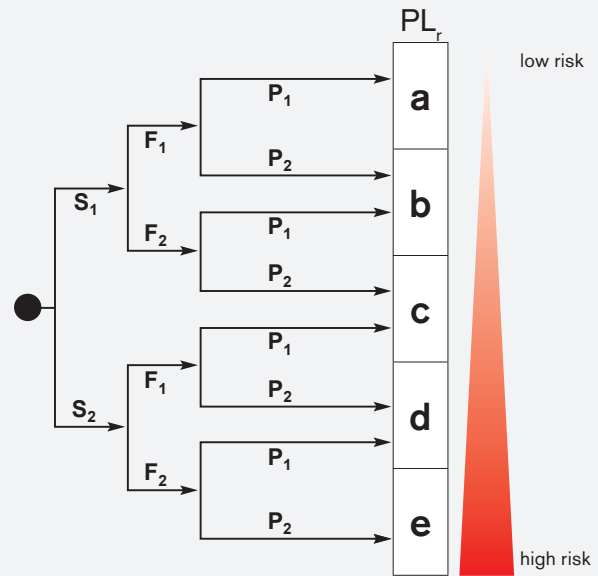

## Step 3

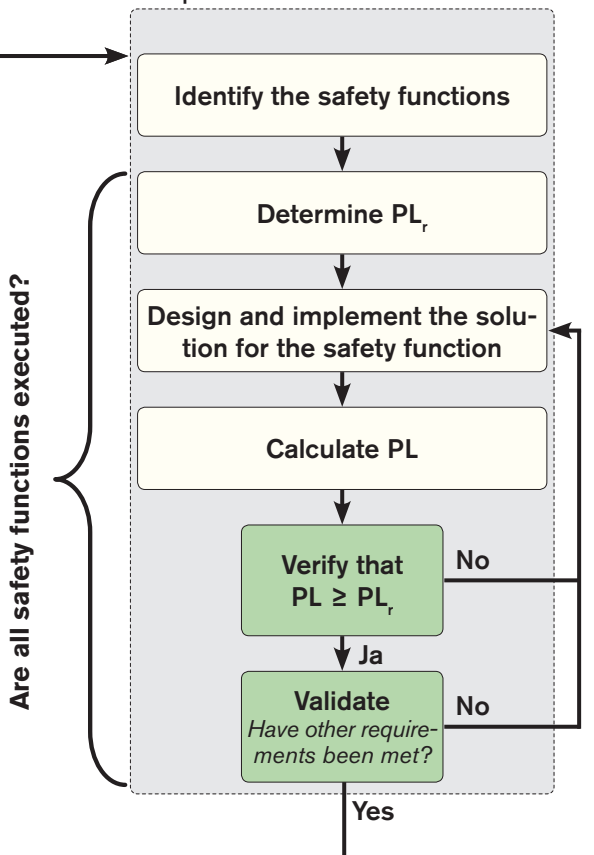

## Step 2 – Reduce the risk

If you determine that risk reduction is required, you must comply with the priority in the Machinery Directive in the selection of measures:

1. *Avoid the risk already at the design stage. (For example, reduce power, avoid interference in the danger zone.)*
2. *Use protection and/or safety devices. (For example, fences, light grids or control devices.)*
3. *Provide information about how the machine can be used safely. (For example, in manuals and on signs.)*

If risk reduction is performed using safety devices, the control system that monitors these needs to be designed as specified in EN ISO 13849-1.

## Step 3 - Design and calculate the safety functions

To begin with you need to identify the safety functions on the machine. (Examples of safety functions are emergency stop and monitoring of gate.)

For each safety function, a  $PL_r$  should be established (which has often already been made in the risk assessment). The solution for the safety function is then designed and implemented. Once the design is complete, you can calculate the PL the safety function achieves. Check that the calculated PL is at least as high as  $PL_r$  and then validate the system as per the validation plan. The validation checks that the specification of the system is carried out correctly and that the design complies with the specification. You will also need to verify that the requirements that are not included in the calculation of the PL are satisfied, that is, ensure that the software is properly developed and validated, and that you have taken adequate steps to protect the technical approach from systematic errors.

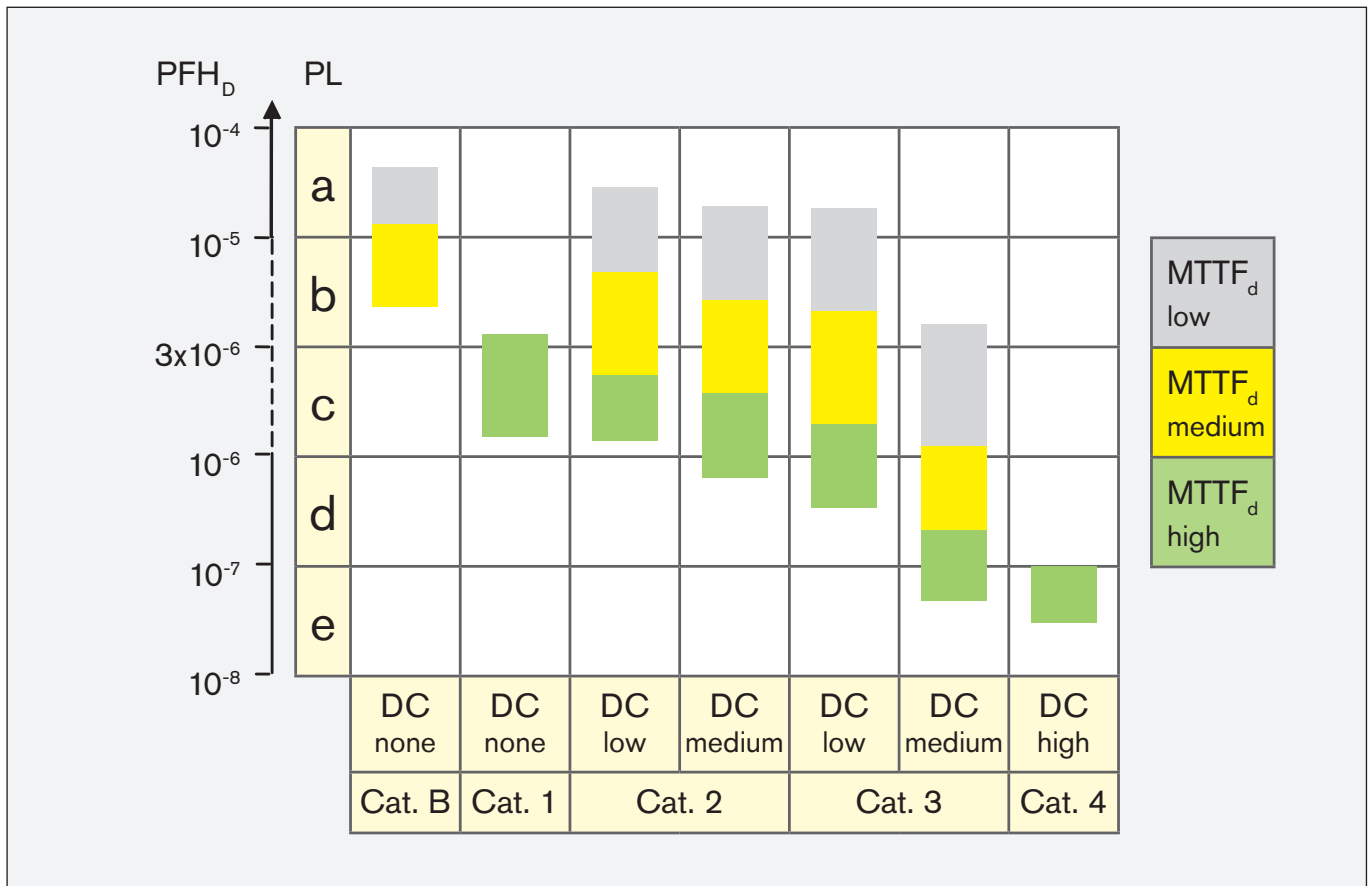

The relationship between categories, the  $DC_{avg}$ ,  $MTTF_d$  for each channel and PL. The table also shows the  $PFH_D$ -range that corresponds to each PL.

### PL calculation in Step 3

When you calculate the PL for a safety function, it is easiest to split it into separate, well defined blocks (also called subsystems). It is often logical to make the breakdown according to input, logic and output (e.g. switch - safety relay - contactors), but there may be more than three blocks depending on the connection and the number of components used (an expansion relay could for example create an additional logic block).

For each block, you calculate a PL or  $PFH_D$ -value. It is easiest if you obtain these values from the component manufacturer, so you do not have to calculate yourself. The manufacturer of switches, sensors and logic devices

often have PL and  $PFH_D$ -values for their components, but for output devices (such as contactors and valves) you do not usually specify a value as it depends on how often the component will be used. You can then either calculate yourself according to EN ISO 13849-1 or use the pre-calculated example solutions such as those from ABB Jokab Safety.

To calculate PL or  $PFH_D$  for a block, you need to know its category, DC and  $MTTF_d$ . In addition, you need to protect yourself against systematic errors and ensure that an error does not knock out both channels, and generate and validate any software used correctly. The following text gives a brief explanation of what to do.

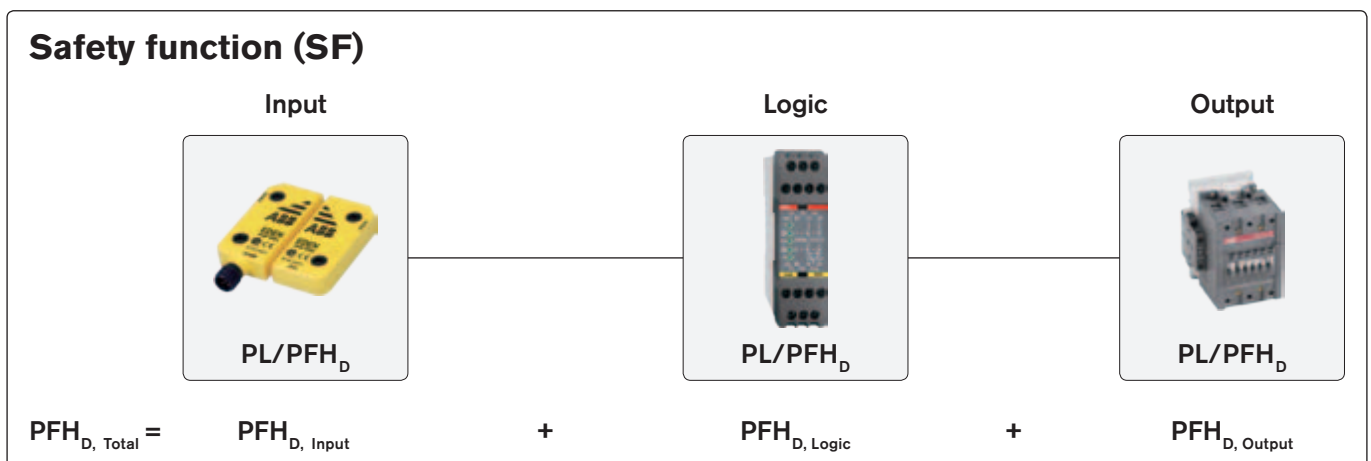

## Category

The structure for the component(s) in the block is assessed to determine the category (B, 1-4) it corresponds to. For category 4, for example, individual failures do not result in any loss of the safety function.

In order to achieve category 4 with contactors, you need to have two channels - *i.e.*, *two contactors* - that can cut the power to the machine individually. The contactors need to be monitored by connecting opening contacts to a test input on, for example a safety relay. For monitoring of this type to work, the contactors need to have contacts with positive opening operation.

## Diagnostic Coverage (DC)

A simple method to determine DC is explained in Appendix E in EN ISO 13849-1. It lists various measures and what they correspond to in terms of DC. For example, DC=99 % (which corresponds to DC high) is achieved for a pair of contactors by monitoring the contactors with the logic device.

## Mean Time To dangerous Failure (MTTF<sub>d</sub>)

In calculating the MTTF<sub>d</sub> for the block your starting point is the B<sub>10d</sub>-value (average number of cycles until 10 % of the components have a dangerous failure). To calculate the MTTF<sub>d</sub>, you also need to know the average number of cycles per year that the component will execute.

Calculation of the average number of cycles is as follows:

$$MTTF_d = \frac{B_{10d}}{0,1 \cdot n_{op}}$$

*där*

$$n_{op} = \frac{d_{op} \cdot h_{op} \cdot 3600}{t_{cycle}}$$

- n<sub>op</sub> = Number of cycles per year
- d<sub>op</sub> = Operation days per year
- h<sub>op</sub> = Operation hours per day
- t<sub>cycle</sub> = Cycle time (seconds)

Example: d<sub>op</sub> = 365 days, h<sub>op</sub> = 24 hours and t<sub>cycle</sub> = 1,800 seconds (2 times/hour) which gives n<sub>op</sub> = 17,520 cycles.

## Requirements for safety-related software

If you use a safety PLC for implementing safety functions, this places demands on how the software is developed and validated. To avoid error conditions, the software should be readable, understandable and be possible to test and maintain.

A software specification must be prepared to ensure that you can check the functionality of the program. It is also important to divide the program into modules that can be tested individually. Paragraph 4.6 and Appendix J of EN ISO 13849-1 specify requirements for safety related software.

With a B<sub>10d</sub>=2·10<sup>6</sup> this gives a MTTF<sub>d</sub>=1,141 year which corresponds to MTTF<sub>d</sub>=high.

Note that when you calculate MTTF<sub>d</sub> you have to calculate according to the total number of cycles the component will be working. A typical example of this is the contactors that frequently work for several safety functions simultaneously. This means that you must add the number of estimated cycles per year from all the safety functions that use the contactors.

For electromechanical, mechanical and pneumatic components whose MTTF<sub>d</sub> is calculated from a B<sub>10d</sub>-value, the following applies.

Also consider that if the MTTF<sub>d</sub>-value is less than 200 years, the component needs to be replaced after 10 % of the MTTF<sub>d</sub>-value (due to the T<sub>10d</sub>-value). That is, a component with MTTF<sub>d</sub> = 160 years needs to be replaced after 16 years in order for the conditions for achieving PL to continue to be valid. This is because EN ISO 13849-1 is based on a "mission time" of 20 years.

## Common Cause Failure (CCF)

In Appendix F of EN ISO 13849-1 there is a table of actions to be taken to protect against CCF, to ensure a failure does not knock out both channels.

## Systematic errors

Appendix G of EN ISO 13849-1 describes a range of actions that need to be taken to protect against incorporating faults into your design.

## PL for safety functions

PL is given in the table on the facing page. If you want to use an exact PFH<sub>D</sub>-value instead, this can be produced using a table in Appendix K in EN ISO 13849-1.

Once you have produced the PL for each block, you can generate a total PL for the safety function in Table 11 of EN ISO 13849-1. This gives a rough estimate of the PL. If you have calculated PFH<sub>D</sub> for each block instead, you can get a total of PFH<sub>D</sub> for the safety function by adding together all the values of the blocks. The safety function's total PFH<sub>D</sub> corresponds to a particular PL in Table 3 of EN ISO 13849-1.

The following are examples of requirements for software from EN ISO 13849-1:

- A development life cycle must be produced with validation measures that indicate how and when the program should be validated, for example, following a change.
- The specification and design must be documented.
- Function tests must be performed.
- Validated functional blocks must be used whenever possible.
- Data and control flow are to be described using, for example, a condition diagram or software flow chart.

# What defines a safety function?

Calculating that you have achieved the PL<sub>r</sub> that is required is not difficult, especially if you use “pre-calculated” safety devices and logic units. But what parts should then be included in each safety function? This must be resolved before you start calculating phase. To summarise in simple terms you can say that each safety device gives rise to a safety function for each machine that is affected by the safety device in question. Three safety devices that all cut the power to three machines in a cell is therefore equal to nine safety functions. In the section that follows, we explain the background.

## Multiple safety functions for a machine

Multiple safety devices are often used on a machine in order to provide satisfactory and practical protection for the operators. In the following example, the machine is protected by three safety devices connected to a logic device. The following figure illustrates this interconnection schematically.

Three safety functions (SF) are defined for the machine and are calculated as:

$$SF1: PFH_{D' F1} + PFH_{D' K1} + PFH_{D' Q1} = PFH_{D' SF1}$$

$$SF2: PFH_{D' B1} + PFH_{D' K1} + PFH_{D' Q1} = PFH_{D' SF2}$$

$$SF3: PFH_{D' S1} + PFH_{D' K1} + PFH_{D' Q1} = PFH_{D' SF3}$$

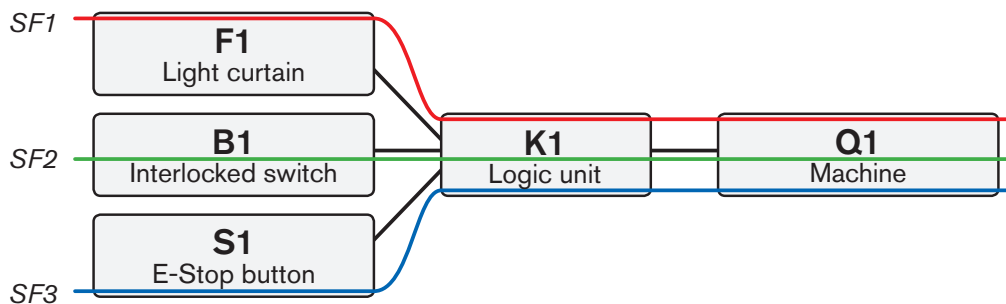

## Multiple safety functions for multiple machines in a cell

More commonly, several machines in a single cell/zone are to be protected by multiple safety devices. The following figure illustrates the interconnection schematically for an example. Each of the machines Q1 – Q3 is shut down separately and independently of K1.

If the operator enters the cell, he is exposed in this case to the same type of risk from all three machines. The power to all three machines must be cut when the operator enters the cell through the door interlocked by B1.

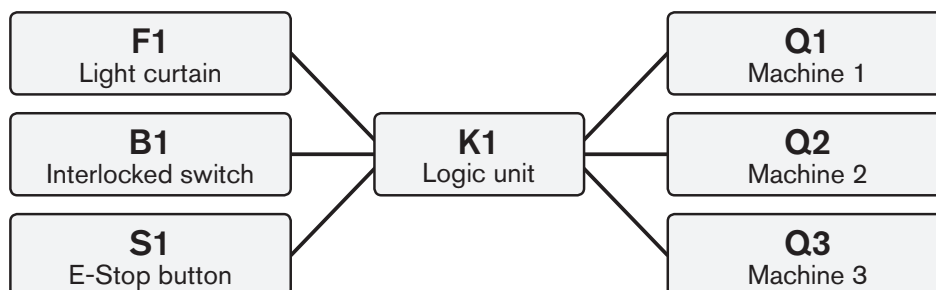



## Theoretical approach for multiple machines

The theoretical approach to calculate the safety function is as follows:

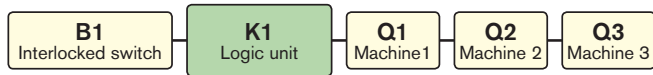

For the full safety function to be performed you require all the components to be working. Note that if B1 or K1 has a dangerous malfunction, the entire safety function is disabled. However, if for example machine Q1 has a dangerous malfunction, and is not shut down, machines Q2 and Q3 will still be shut down. One disadvantage in considering the safety function in this way is that you may have trouble achieving the  $PL_r$  required. But if you achieve the  $PL_r$  required, you can use the theoretical approach.

### Sources:

[www.dguv.de/ifa/de/pub/grl/pdf/2009\\_249.pdf](http://www.dguv.de/ifa/de/pub/grl/pdf/2009_249.pdf)  
[www.bg-metall.de/praevention/fachausschuesse/infoblatt/deutsch.html](http://www.bg-metall.de/praevention/fachausschuesse/infoblatt/deutsch.html)  
(No 047, Date 05/2010)

## Practical approach for multiple machines

A more practical approach is to divide the safety function into three parts, one for each of the three machines.

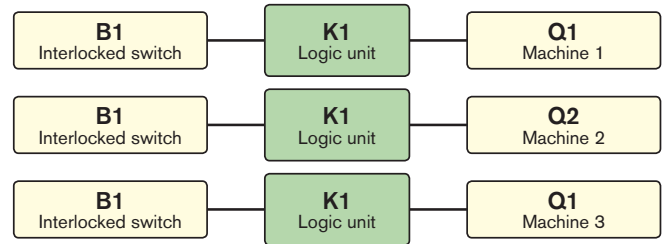

This is an approach that can provide a more accurate way of looking at the safety functions, especially where a different  $PL_r$  is required for the safety functions above. If machine Q1 is a robot and machine Q2 is a conveyor which is designed to have negligible risks, the different  $PL_r$  required to protect against risks from Q1 and Q2 will also be different. This practical approach is therefore the one recommended. The interpretation is based on information provided by IFA (Institut für Arbeitsschutz der Deutschen Gesetzlichen Unfallversicherung). For more information on this and other issues, see Sources.

## Example of safety functions for multiple machines in a cell

For a cell with three machines (one robot, one hydraulic press and one pneumatic machining tool) a risk assessment is made resulting in different  $PL_r$  for the individual machines. The robot and the hydraulic press requires  $PL_r = e$ , while the pneumatic machining tool requires  $PL_r = d$ .

One of the safety functions is that a non-contact sensor (Eden) supervised by a safety PLC (Pluto) shall disconnect the energy to all three machines in the hazard zone:

- Eden B1 ( $PFH_{D', B1} = 4,5 \cdot 10^{-9}$ )
- Pluto K1 ( $PFH_{D', K1} = 2 \cdot 10^{-9}$ )
- Robot Q1 ( $PFH_{D', Q1} = 5,79 \cdot 10^{-8}$ )
- Hydraulic press Q2 ( $PFH_{D', Q2} = 8 \cdot 10^{-8}$ )
- Pneumatic machining tool Q3 ( $PFH_{D', Q3} = 2 \cdot 10^{-7}$ ).

### Practical approach

If you use the practical approach the safety functions are as follows:

Robot:

$$PFH_{D', B1} + PFH_{D', K1} + PFH_{D', Q1} = 4,5 \cdot 10^{-9} + 2 \cdot 10^{-9} + 5,79 \cdot 10^{-8} = 6,44 \cdot 10^{-8} \longrightarrow PL e$$

Hydraulic press:

$$PFH_{D', B1} + PFH_{D', K1} + PFH_{D', Q2} = 4,5 \cdot 10^{-9} + 2 \cdot 10^{-9} + 8 \cdot 10^{-8} = 8,65 \cdot 10^{-8} \longrightarrow PL e$$

Pneumatic machining tool:

$$PFH_{D', B1} + PFH_{D', K1} + PFH_{D', Q3} = 4,5 \cdot 10^{-9} + 2 \cdot 10^{-9} + 2 \cdot 10^{-7} = 2,07 \cdot 10^{-7} \longrightarrow PL d$$

This is to be done in a similar way with other safety functions for the cell. For each safety device, you define the machines it affects, and establish the various safety functions according to this.

### Theoretical approach

How would it have worked if you had used the theoretical approach? Would the safety function have achieved  $PL e$ ?

All machines:

$$PFH_{D', B1} + PFH_{D', K1} + PFH_{D', Q1} + PFH_{D', Q2} + PFH_{D', Q3} = 4,5 \cdot 10^{-9} + 2 \cdot 10^{-9} + 5,79 \cdot 10^{-8} + 8 \cdot 10^{-8} + 2 \cdot 10^{-7} = 3,44 \cdot 10^{-7} \longrightarrow PL d$$

In this case, the safety function would therefore have not achieved a total  $PL e$ , which was required for the risks associated with a robot and hydraulic press.

### Conclusions

- Use the practical approach.
- Use safety devices/logic units with high reliability (low  $PFH_D$ ) to make it easy to achieve the  $PL_r$  required.
- With Vital or Pluto, it is easier to achieve the  $PL_r$  required.

Please note that the examples on these pages are simplified in order to explain the principles. Values of products can also change.

# Applying EN 62061

If one chooses to design a safety function in accordance with EN 62061, the level of reliability is expressed as the Safety Integrity Level, SIL. There are a total of 4 levels, but in the EN 62061 standard SIL 3 is the highest level. SIL also (similar to the Performance Level PL), is expressed as the Probability of Dangerous Failure Per Hour.

Safety Integrity Level, SIL	Probability of dangerous Failure per Hour (PFH <sub>D</sub> )
3	$\geq 10^{-8}$ to $< 10^{-7}$
2	$\geq 10^{-7}$ to $< 10^{-6}$
1	$\geq 10^{-6}$ to $< 10^{-5}$

There is a method in EN 62061 for assigning the Safety Integrity Level.

Severity (Se)	Class (Cl)				
	3-4	5-7	8-10	11-13	14-15
4	SIL2	SIL2	SIL2	SIL3	SIL3
3		(OM)	SIL1	SIL2	SIL3
2			(OM)	SIL1	SIL2
1				(OM)	SIL1

Cl=Fr+Pr+Av      OM=Other Measures

The seriousness of injury that can occur is defined at one of four levels. Class is the addition of the values of frequency (Fr, stated as a value between 1 and 5, where 5 represents the highest frequency), probability that a dangerous event will occur (Pr, stated as a value between 1 and 5, where 5 represents the highest probability) and the possibility of avoiding or limiting injury (Av, stated as a value of 1, 3 or 5, where 5 represents the least chance of avoiding or limiting an injury).

The safety function that is to be designed must at least fulfil the SIL that has been assigned to it in the analysis. The safety function consists of a number of sub-elements. Example: a door is interlocked by a non-contact sensor which is in turn monitored by a Pluto safety PLC, with outputs that break the power to two supervised contactors. The sensor is sub-element 1, Pluto is sub-element 2 and the two supervised contactors are sub-element 3. If in the analysis it has been established that SIL2 shall be used, every individual sub-element in the safety function must fulfil the SIL2 requirements. The safety function must then in its entirety fulfil the SIL2 requirements.

## Definition of protective safety in accordance with EN 62061

"Function of a machine whose failure can result in an immediate increase of the risk(s)"

If the SIL requirements are not fulfilled in any of the sub-elements or by the safety function in its entirety, there must be a re-design.

## Finally

This is just a brief introduction to the EN ISO 13849-1 and EN 62061 standards. You are welcome to contact us so that we can prepare suitable training and guide you in how to apply the standards to our products.

# A mechanical switch does not give a safe function!

## A mechanical switch does not give a safe function!

When it comes to mechanically operated interlocked switches, it has long been accepted a Category 1 switch is adequate for many installations, which is also supported by several standards. However some companies have now re-evaluated this and have instead started to demand two mechanical switches or non-contact switches/sensors, where they previously accepted single mechanical switches. Many reported incidents form the background to this. The requirements for switches to provide safe functioning are that they are mounted correctly and that their positions do not change during their life-cycle, in other words, ideal conditions. In many installations the location of hatches or doors changes over time. This has led to a switch not giving a stopping signal when an interlocked gate has opened. The reasons for this are many, but they can be summarized in mechanical deterioration or physical damage to a door/hatch. In turn this has led to an interlocked switch being affected by higher stress than the switch manufacturer's specifications. To avoid this type of malfunction it is more appropriate to use non-contact switches/sensors because mechanical deterioration does not affect the safety function, i.e. the stop signal is given directly if the position is wrong.

A non-contact switch/sensor does not have a guided function and is designed to fulfill the requirements in another way. The requirements are fulfilled either with dynamic sensors where the safety signal is monitored all the time and a fault directly leads to a stop signal or with a magnetic switch which has two independent contact elements which are monitored every time a gate opens. From the user's perspective the dynamic function is preferable because several sensors can be connected to a single safety module and still achieve PL e. Also the sensor's safety function is monitored without having to open a gate. For a magnetic switch the requirements for PL e are only fulfilled if one switch per monitoring unit is used and if the gate is opened regularly.

If PL e is to be achieved with electromechanical switches, maximum two switches can be connected to one safety relay.

This means that it is only with Eden that several doors can be supervised with one safety module and achieve PL e.

Since the standard EN 954-1 was written, development has progressed and the costs to fulfill category 4 have dropped dramatically. Generally mechanical switches are replaced with non-contact sensors to increase the reliability of production equipment. The same goes for the safety side. With electronic non-contact switches, with a transmitter and a receiver, one avoids the problems of deterioration and excessive stress which harm the sensor. For that kind of sensor dynamic monitoring is required to enable a safe function. This means that its function is constantly being monitored, hundred of times per second. The reaction time for a safe stop will then be the same during a malfunction as during the activation of a stop (e.g. a gate opening). The monitoring frequency will also be astronomical compared to that of mechanical switches and magnetic switches, which are only monitored every time they are used. In the new EN ISO 13849-1, which will replace 954-1, probability calculations are used together with different category levels to compare different "performance levels". Even when using EN ISO 13849-1 it can be so that one achieves reasonably high theoretical reliability with an electromechanical switch, although this presumes correct installation, proper use and otherwise ideal conditions. A non-contact switch instead provides high levels of both theoretical and practical reliability.

## Our conclusion, use dynamic signals!

Our conclusion is that today it is more cost effective, safer and more reliable to work with dynamic signals to achieve category 4 for sensors and monitoring units. In that case it is also possible to fulfill the Machinery Directive, 1.2.7. requirement: "A fault in the control circuit logic, or failure of or damage to the control circuit, must not lead to dangerous situations". Also one does not have to discuss whether the correct safety category has been chosen!

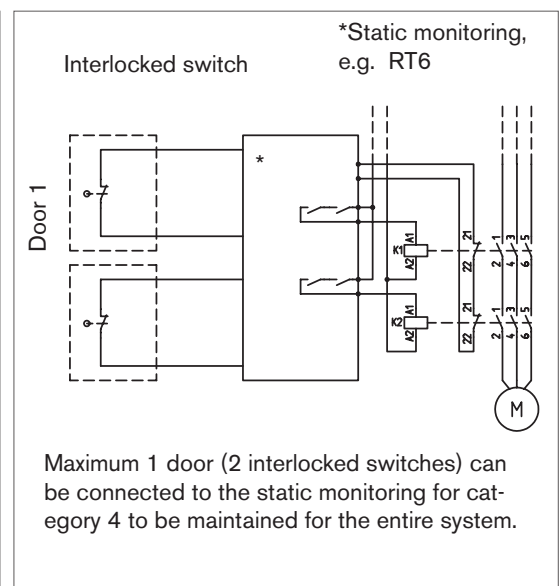
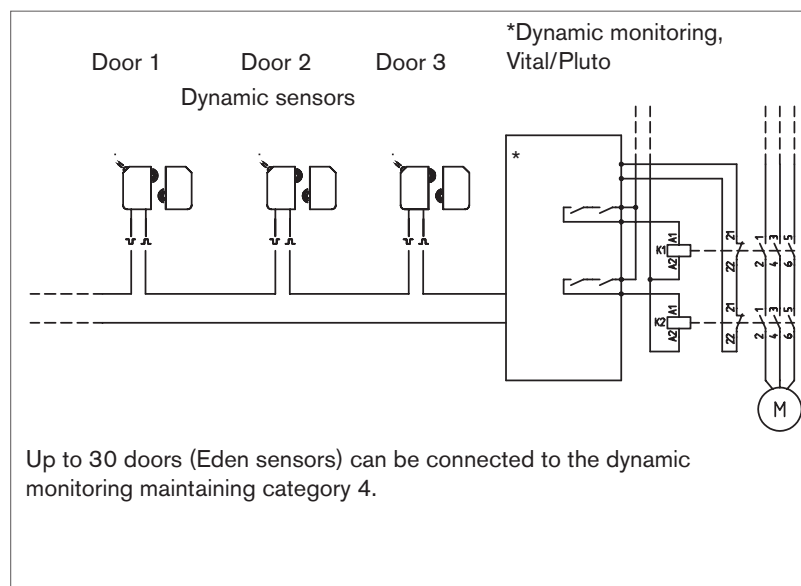

# We train you on safety requirements

- enhance your knowledge!

## What requirements are there today?

For international companies there are many new standards and regulations with which to comply. There have also been changes and revisions of existing standards and directives.

As a business and designer one is obliged to know about and to follow all the regulations. But it can be difficult for each individual company to keep track of all the new regulations and how they should be applied.

Your local ABB Jokab Safety sales office can help you with training and analysis during a build-up phase or as a continuous consulting assignment.



## Our course trainers have a extensive experience in machine safety

A distinguishing feature of all the engineers at ABB Jokab Safety is that they work daily with practical applications of standards and regulations. This is true for everything from safety components for individual machines to entire deliveries of safety systems for larger production lines. Within the company there is also a very good knowledge of machine control and production. We are also represented in standardisation groups which decide on European and International standards concerning machine safety. Because ABB Jokab Safety is represented globally, we have the knowledge of safety requirements in different countries.

## Training in machine safety

Are you building machines for sale or for your own use? Are you a user of machines? Are you working with automation of production plants or do you make technical evaluations of machines prior to purchase?

Regardless of the purpose, there is a need for knowledge concerning what requirements and regulations exist in respect of machine safety, and how they should be applied.

### We offer company-adapted training in the following fields:

- Product liability and its consequences
- CE-labelling
- The Machine Directive and how to apply it
- Choice of certification procedure with examination of the parts which are required in order to be able to CE-label a machine
- Machine safety analysis; method and cases
- Choice of safety measures/safety devices
- Requirements for manufacturer's technical documentation
- Requirements for manuals
- Requirements for "old machines"
- Harmonised standards and the applications of these, e.g.
  - EN ISO 13849-1/-2
  - EN ISO 12100
  - EN 60204-1
  - EN ISO 13850
  - EN ISO 13857
  - EN ISO 13855 (previously EN 999)
- Specific interpretation cases, e.g. re-construction of machines
- Forthcoming changes in the Machine Directive

### Company-adapted training in machine safety

Contact your local sales office with questions and your current training needs. Together with you, we will customize the training to your specific company requirements.



# Training in risk analysis

We regularly have training courses in our offices. One of these covers risk analysis and how to choose production adapted measures.

## A course in risk analysis contains the following:

- Risk analysis - from theory to practice
- What durability towards errors shall the safety system have?
- Standard EN ISO 13849-1/-2
- Safety distances for fencing systems and safety components - how do you choose?
- Cases, practice and briefing of risk analysis and choice of actions

## Product training

Our unique Pluto Safety PLC gives new and great possibilities to build-up a cost effective and flexible safety system. With this also comes the demands of higher knowledge. For you as a customer to be able to quickly get started using Pluto in the most effective way and to learn about its possibilities, we regularly offer trainings at our local sales offices. In the training course cost is included a Pluto, software for Pluto and full documentation. We also offer training on the other ABB Jokab Safety products such as the Vital solution, safety relays and light beams/curtains.

### Training - Pluto and other ABB Jokab Safety products

Contact your local sales office with questions and your current training needs. Together with you, we will customize the training to your specific company requirements.

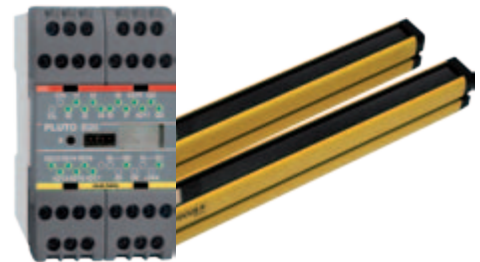

## Consulting

Do you need assistance in CE-marking a machine? Do you want a third party to carry out a risk analysis on a machine line? Do you have the need of a partner to examine how various regulations effect the safety of your machines?

We can offer assistance and support in both short and longer assignments. Here are a few examples of what we can offer you:

- **Risk analysis** with proposal of measures. We do this together with the customer and it is often done as a pilot-project so that the company afterwards themselves can carry out analysis.
- Guide the customer business through a **CE-marking** of machine/plant.
- Write/review **technical documentation/manuals**
- **Interpret** standards and regulations
- **Stopping time measurement** - We can measure the stopping time on your machines with our Stopping time and motion analyser tool. Knowledge of the stopping time is a prerequisite to be able to determine the correct safety distance. EN ISO 13855 (previously EN 999) gives the requirements.
- **Programming** of Pluto Safety-PLC.



*Stopping time measurement is required in order to be able to determine the correct safety distance.*

### Consulting - Contact us

Come to us with your needs and we will plan with you a suitable project programme. You can also contact us with short questions which we can solve directly over the phone or via e-mail.

# Pluto Safety PLC

With dynamic safety concept.

## Pluto/Gateway/Encoder

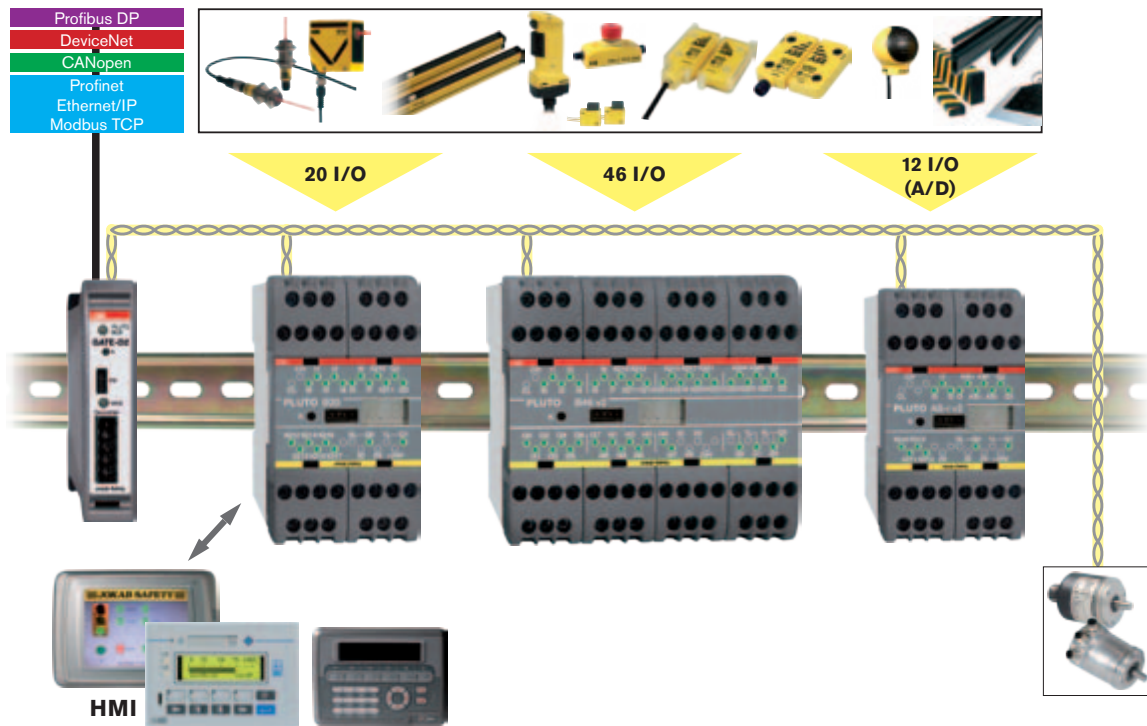

<b>Contents</b>	<b>Page</b>
<b><i>Why you should use the Pluto safety PLC</i></b> _____	<b>2:2</b>
<b><i>Pluto safety PLC</i></b> _____	<b>2:6</b>
▪ Pluto without databus _____	<b>2:8</b>
▪ Pluto with databus _____	<b>2:12</b>
▪ Certification _____	<b>2:15</b>
▪ Example – Robot cell with Pluto _____	<b>2:16</b>
 <b><i>Pluto gateway</i></b>	
▪ Gate P2-Profibus DP _____	<b>2:24</b>
▪ Gate D2-DeviceNet _____	<b>2:26</b>
▪ Gate C2-CANOpen _____	<b>2:28</b>
▪ Gate E2-Profinet, Ethernet/IP, Modbus TCP _____	<b>2:30</b>
 <b><i>Safe Encoder</i></b> _____	<b>2:32</b>

Descriptions and examples in this book show how the products work and can be used. This does not mean that they can meet the requirements for all types of machines and processes. The purchaser/user is responsible for ensuring that the product is installed and used in accordance with the applicable regulations and standards. We reserve the right to make changes in products and product sheets without previous notice. For the latest updates, refer to [www.abb.com/lowvoltage](http://www.abb.com/lowvoltage). 2011.

# Why you should have Pluto safety PLC's.

– for simplifying the design of and changes to safety systems!

Pluto is an "All-Master" safety PLC concept, that simplifies the design of safety systems and achieves the highest safety level PL e according to EN ISO 13849-1 and SIL 3 according to EN 62061 and EN 61508. The key difference between Pluto and conventional safety PLC's is that there is no "Master-Slave" relationship between the control units connected to the safety bus. Each Pluto is a 'Master' unit and can see the other Plutos' inputs and outputs, and can thereby make decisions about its own safety environment.

This concept enables simple communication, programming and changes to the safety system. With the use of a 'Gateway' device, a Pluto can communicate with other bus systems and thereby form part of a larger network. Gateway units are available for several different bus systems, such as Profibus, CanOpen, DeviceNet, Profinet, Ethernet/IP and Modbus TCP. With a Pluto AS-i, both safety slaves and standard slaves can be handled.

Pluto offers an economic solution for both single machines and for major machine systems.

## Our solution with All-Master

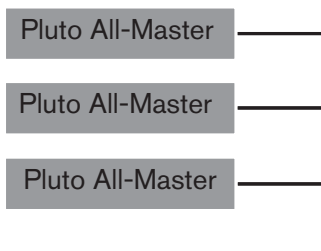

## Traditional safety PLC

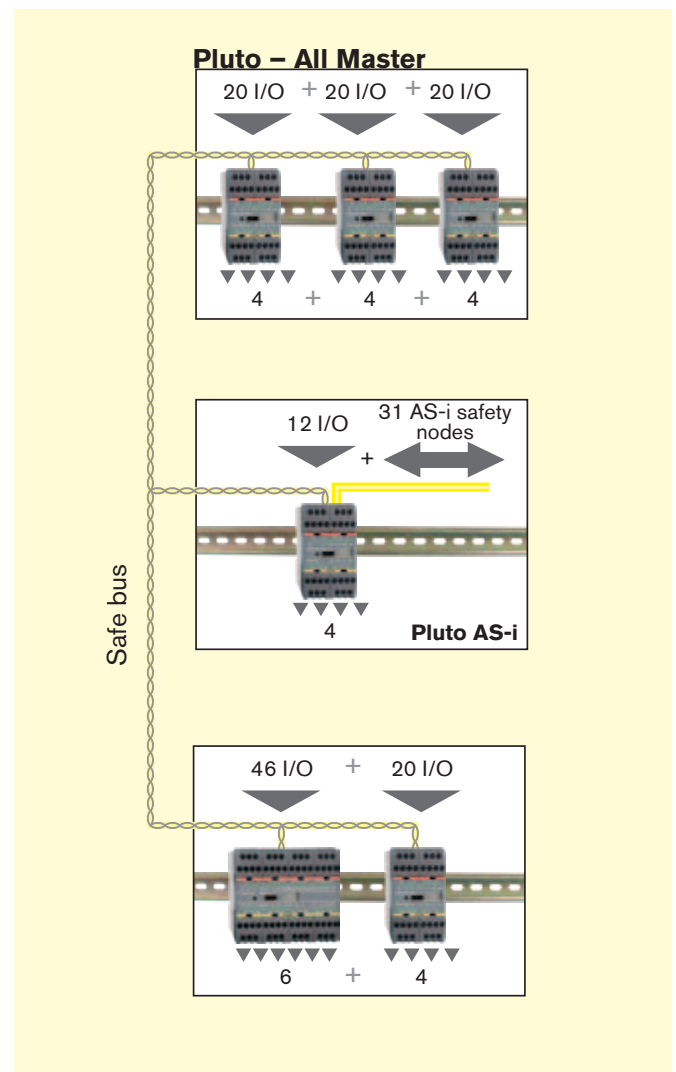
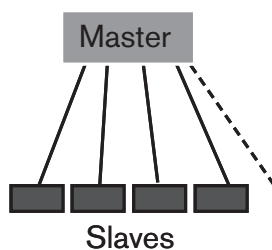



**- to supervise safety devices!**

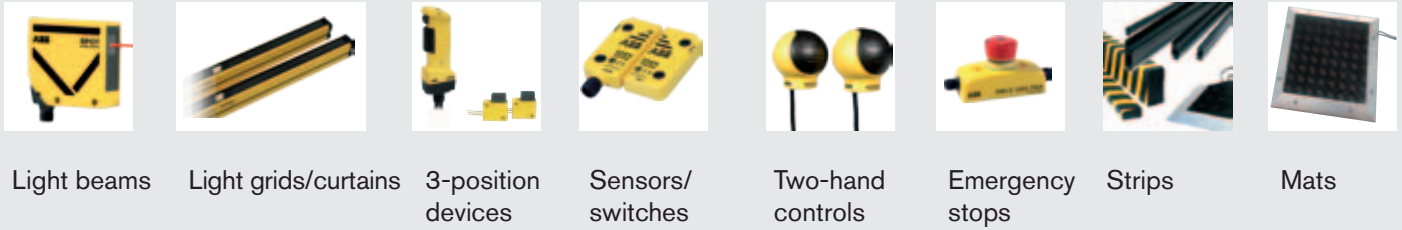

Light beams    Light grids/curtains    3-position devices    Sensors/switches    Two-hand controls    Emergency stops    Strips    Mats

Most safety devices on the market can be connected directly to Pluto units. By using dynamic signals with sensors from ABB Jokab Safety only one input is needed to achieve the highest level of safety, compared to two inputs for other manufacturers' PLCs. It is also possible to connect up to 10 sensors in series to a single input on Pluto and still achieve the highest level of safety. For example non-contact Eden

sensors, Spot light beams and Tina emergency stop buttons can all be connected in series to a single Pluto input. Even mechanical switches can be connected to the 'dynamic' safety circuit using ABB Jokab Safety's various Tina adapters. Pluto also has IO connections that can be used as both inputs and outputs.

**- to save on inputs!**

**Dynamic signals**

1-10 doors with one Eden per door  
PL e

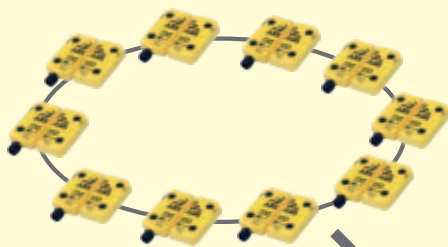

One input

**Dynamic signals**

1-10 sensors  
PL e

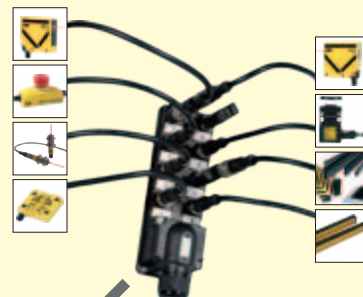

One input

**Pluto**

has inputs for static and dynamic sensors. Several sensors can be connected to one dynamic input in accordance with PL e.



One connection

Two inputs

**IO connections**

Pluto has IO connections that can be used in three ways:

- input
- output
- both input and output at the same time (e.g. for a reset button with lamp indication)

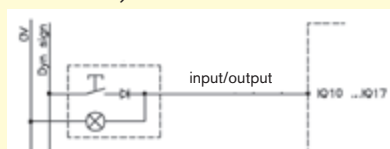

**Static inputs (mechanical switches)**

2 for each door = PL e



## Pluto safety PLC – an overview

### Pluto with a safety bus

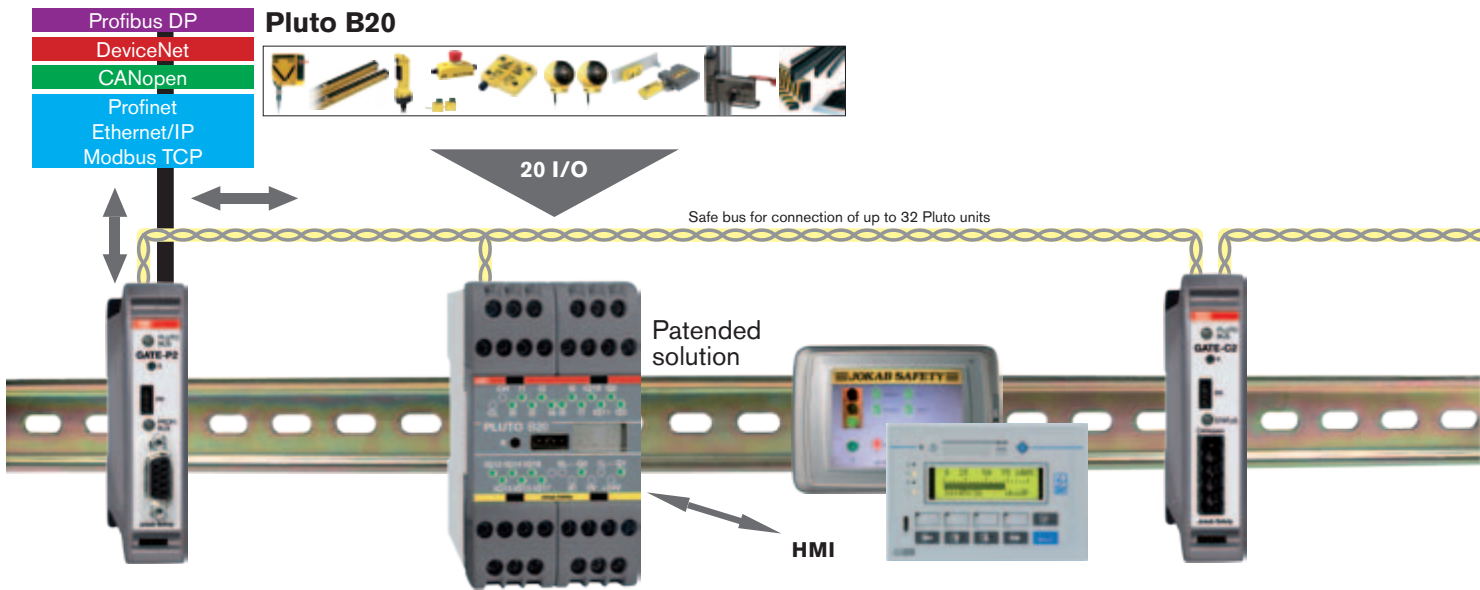

**Gateway** for two-way databus communication between Pluto and other control systems.

**Pluto** is an All-Master-System for dynamic and static safety circuits where the inputs and other information are shared on a databus. Several safety sensors can be connected to one input while still achieving the highest level of safety. Pluto has inputs for all safety devices on the market, and the Pluto Manager software selects how each input shall respond.

4 independent failsafe safety outputs

**HMI**, An HMI operator panel can communicate with Pluto in both directions. Connection can be made via the bus or direct to the front of the Pluto. The interface is RS232 and the protocol is Modbus ASCII 8 bit.

**Pluto bridge**  
With a Gateway set up as a Pluto bridge, it is possible to:

- increase the databus length
- use different databus speeds for each section
- filter information from one section to reduce the databus loading on other sections.

### Pluto without a safety bus – Singel-Pluto

A single Pluto can be used as a fully programmable safety logic controller.

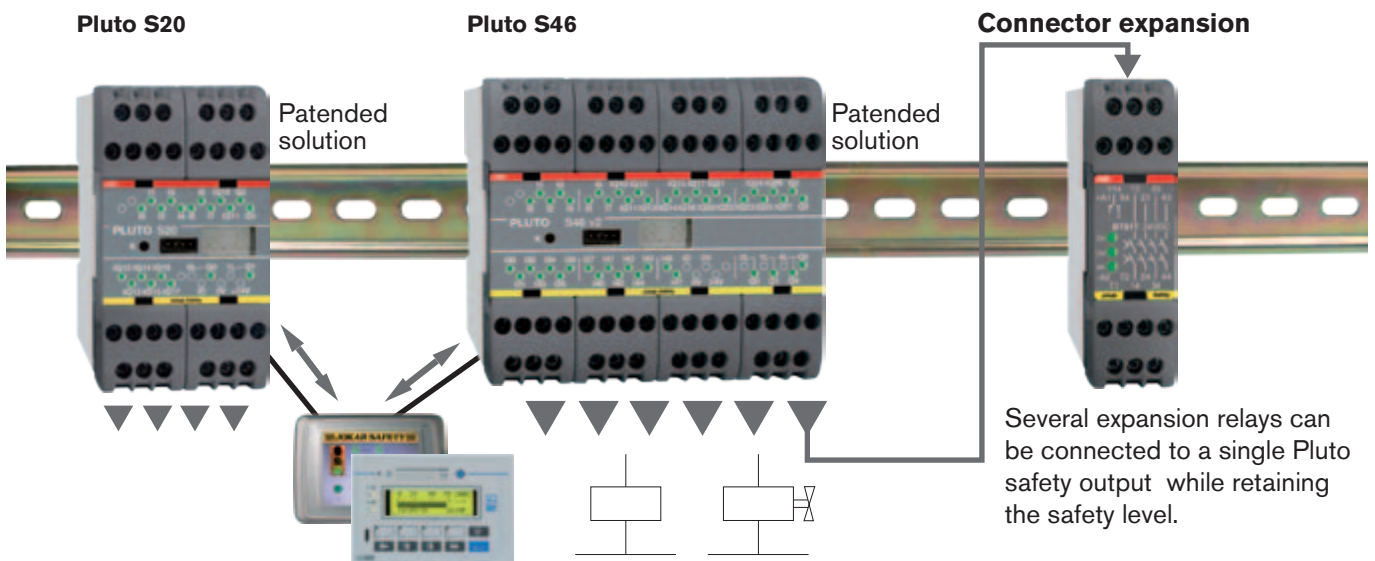

Pluto without a bus connection is available in two sizes, with 20 and 46 I/O , the S20 and S46 respectively. In other words, they are similar to the equivalent versions with bus connections, the B20 and B46.

## Pluto B46



46 I/O

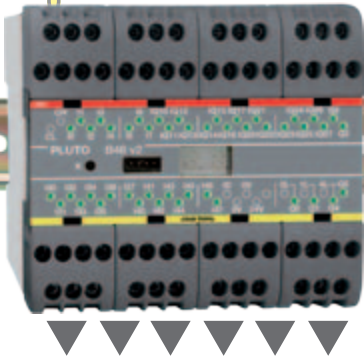

6 independent  
failsafe safety outputs

Patented  
solution

Patented  
solution

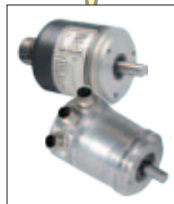

**Absolute encoder.**  
8 single turn or multi  
turn absolute encoders  
can be connected di-  
rectly to the safety bus.

## Pluto AS-i

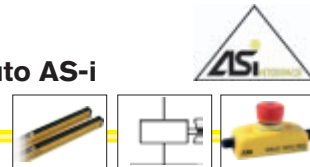

Safety Monitor/Master

12 I/O  
(A/D)

31 AS-i safety slaves



4 independent  
failsafe safety outputs

**Approvals**  
EN 954-1, Category 4  
EN ISO 13849-1, PL e  
EN 61496-1, Type 4  
EN 61508, SIL 3  
EN ISO 62061, SIL 3  
EN ISO 60204-1  
EN 50178  
EN ISO 574, Type IIIc



**Pluto AS-i** is an AS-i module which can be con-  
nected to a AS-i bus. It can either be AS-i master  
on the bus or work together with an AS-i master  
as monitor. It includes AS-i nodes, analogue and  
digital outputs, as well as safety outputs.

## IDFIX - identifies Pluto



IDFIX is a identification circuit that is unique to each device on the Pluto bus.  
It includes an identification code and makes it possible to distribute a PLC program  
in the network. There are four different versions: R, RW, DATA and PROG. IDFIX  
PROG also has the current PLC program. If the Pluto PLC module needs to be  
replaced, all the information on this is held in memory at IDFIX.

## Overview Pluto Safety-PLC

Model	S20	S46	A20	B16	B20	B46	AS-i	B42 AS-i
Number of I/O	20	46	20	16	20	46	12	42
Failsafe inputs	8	24	8	8	8	24	4	20
Failsafe inputs or non-failsafe outputs	8	8	8	8	8	8	4	16
Analog inputs	1	3	1	1	1	3	4	3
Failsafe relay outputs	2	4	2	-	2	4	2	4
Failsafe transistor outputs	2	2	2	-	2	2	2	2
Pluto bus	-	-	●	●	●	●	●	●
Current monitoring	-	-	2	-	-	-	-	-
Dimensions (b x h x d) mm	45 x 84 x 118	90 x 84 x 118	45 x 84 x 118	45 x 84 x 118	45 x 84 x 118	90 x 84 x 118	45 x 84 x 118	90 x 84 x 118
Supply voltage	24VDC	24VDC	24VDC	24VDC	24VDC	24VDC	24VDC	24VDC

# Safety PLC

# Pluto

## Approvals:

TÜV Rheinland  

## Control of:

Safety products in dynamic and static circuits  
Electrically controlled actuators such as contactors, valves, motors  
Indicators and buttons

## Features:

A Safety-PLC for each system part  
Dispersed constructions of machines  
Great flexibility  
Up to 10 sensors in series connected to one input  
Software Pluto Manager free of charge  
Handles conventional circuit breakers as well as dynamical sensors  
Custom made safety bus

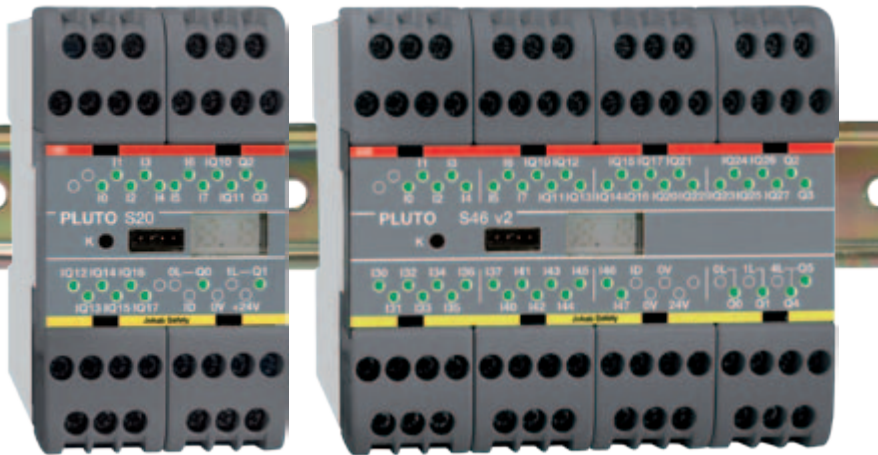

### Pluto Safety PLC facilitates the design of your safety systems

Pluto is an All-Master system for dynamic and static safety circuits where inputs and other information are shared over the bus. Multiple safety sensors can be connected to a single input and still achieve the highest level of safety. Pluto has inputs suited for every safety product on the market, and each input function is configured in the accompanying software Pluto Manager.

Besides failsafe inputs (I) Pluto has a number of failsafe relay and transistor outputs (Q). On every Pluto unit there is also a possibility of using a number of terminals as failsafe inputs, non-failsafe outputs or both in and output simultaneously (IQ). The characteristics of the terminals are easily configured in Pluto Manager.

### Safety in large and small systems

Pluto models without bus communication are stand alone units and are therefore perfectly suited for smaller systems that do not require communication with other Pluto units or gateways. Pluto models with bus communication can be connected to the Pluto bus where up to 32 Pluto units can interact and control large as well as small safety systems. The fact that Pluto is an All-Master system means that each Pluto unit controls their outputs locally, while it is as easy to read other Pluto units' inputs as their own.

Specifically for Pluto A20 is that it is equipped with an analogue input for current measurement, which can be used for e.g. monitoring of muting lamps.

Pluto is primarily designed to satisfy the requirements of EU Machinery Directive (2006/42/EG) regarding safety in control systems, but the system can also be used in other areas as in the process industry, boiler plants etc which have similar requirements.

For product information and downloads please visit

**[www.abb.com/lowvoltage](http://www.abb.com/lowvoltage)**

Click on Control Products, or search for our products at [www.abb.com/abblibrary/downloadcenter](http://www.abb.com/abblibrary/downloadcenter).



## Technical info - Pluto

### Dynamic signal

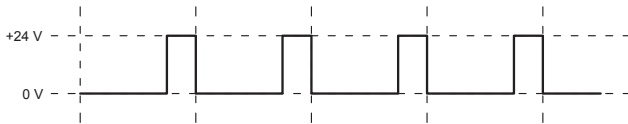

A dynamic signal makes it possible to achieve the highest level of safety with only one conductor. By transmitting a square wave and then evaluating the signal when it comes back to the controller you achieve the redundancy required. The signal is inverted once at each safety sensor (if the protection is OK) which makes it possible to detect short circuits across a sensor. When the signal switches between high (+24 V) and low (0V) it can be evaluated and tested about 200 times per second.

Pluto can generate three unique dynamic signals; A pulse, B pulse or C pulse. Short circuits between two different dynamic signals are detected whenever the signal that is created is different from the expected signal in Pluto. The kind of signal Pluto expects at the input terminal is determined in Pluto Manager (A, B or C pulse and if the signal should be inverted or not).

### Static signal

Static signals (+24 V or 0 V) can be connected to all inputs on Pluto. The kind of signal Pluto expects at the input terminal is determined in Pluto Manager. To achieve a two-channel structure according to EN ISO 13849-1 you need two inputs.

### OSSD-signal

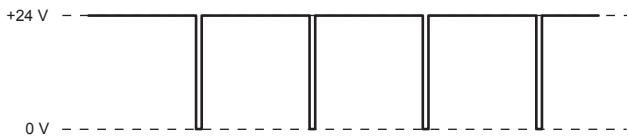

There are safety products with internal monitoring of dual OSSD signals (the device detects its own faults rather than Pluto doing this). From these devices, at least one of the two signals is connected to an I-input in Pluto, i.e. both signals must not be connected to the IQ-terminals. The terminal blocks are then configured in Pluto Manager to expect static inputs (OSSD signals are filtered internally in Pluto).

## Pluto Manager and IDFIX

### Pluto manager

The Pluto Manager is a freeware for fast, easy and safe programming of the PLC program for Pluto. The programming language used is ladder, which is supplemented with TÜV-approved function blocks for many common features. The software can also be used to configure Pluto's terminal blocks, e.g. to specify the IQ terminals that serve as inputs or outputs, and if the controller should expect a static or dynamic signal. Pluto Manager can be downloaded from [www.abb.com/lowvoltage](http://www.abb.com/lowvoltage).

### IQ – individual failsafe inputs and non-failsafe outputs

The IQ terminals can be used either as individual failsafe input or non-failsafe output (e.g. for indicator light or status signal). The terminal blocks can also be used as both input and output simultaneously, which is useful for example for push buttons (input) with indicator light (output). This function is designed primarily for reset buttons to reduce the number of used terminal blocks on the controller.

### I - individual failsafe inputs

All inputs are individually failsafe as each input is connected separately to both processors in Pluto. In order to maintain the redundancy required for two-channel structure and the highest level of safety, the dynamic signal must be used. When using static signals, two inputs must be used to achieve two-channel structure. The expected signal to the terminals blocks is determined in Pluto Manager (static or dynamic signal).

### Q - individual failsafe outputs

All Q outputs are individually safe and are independently programmable. There are both relay outputs and transistor outputs.

### Transistor outputs (-24 VDC)

The transistor outputs are just like the relay outputs, that is individually safe and independently programmable. However, the transistor outputs are different from the relay outputs as the internal connection provides the nominal input voltage -24 VDC, which is primarily intended for controlling electromechanical components such as contactors and valves. As -24 VDC is a unique signal in the majority of electrical cabinets and the fact that the output is monitored by Pluto, short circuits with other potentials can be detected right away.

### Pluto-bus

The Pluto-bus is a CAN-bus with its own safety protocol. The bus cable can be up to 600 m long at the minimum bus speed, and up to 150 m at 400 kb/s. The bus can be both extended and connected to other types of buses through gateways.

### IDFIX

IDFIX is an identification circuit that is unique to each device on the Pluto bus. It includes an identification code and makes it possible to distribute a PLC program in the network. There are four different versions: R, RW, DATA and PROG. In addition to the identification code, DATA may also include safety codes from the AS-i nodes in an AS-i system. PROG includes the current PLC program and is used with single-Pluto for program distribution. IDFIX is connected between the input terminals ID and 0V.

## Pluto without a safety bus

**Single Pluto controls and monitors safety for local systems**  
**- large as well as small systems**



20/46 I/O

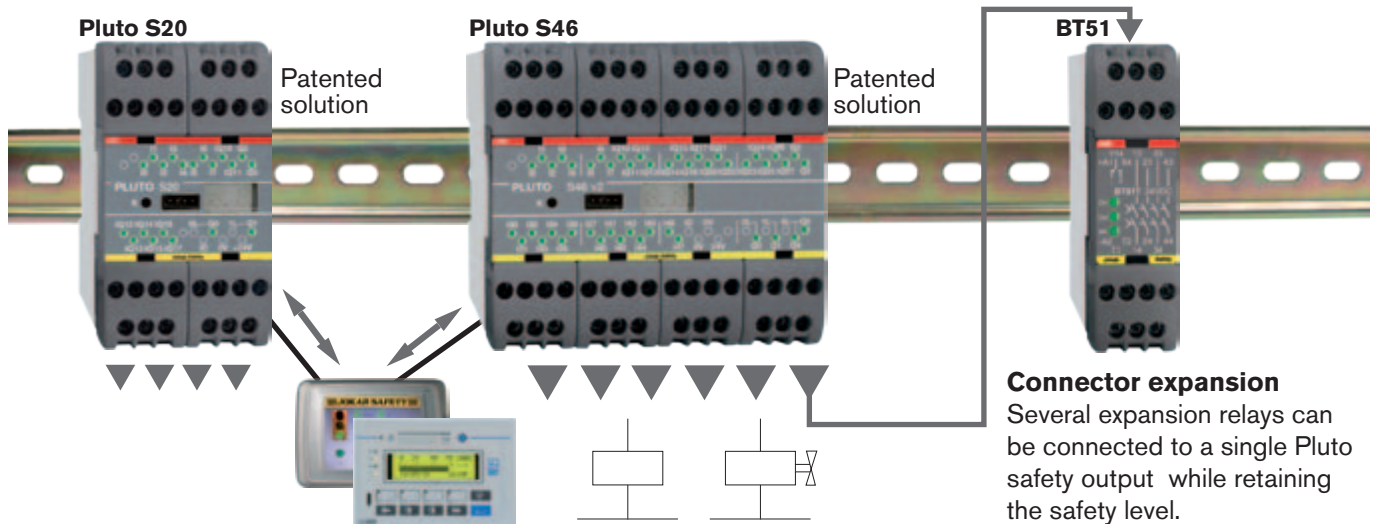

### HMI

A HMI-terminal is easy to connect to one or more Plutos through the Modbus contact.

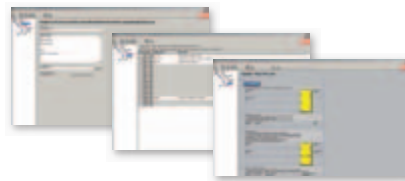

### Pluto Manager

A free of charge software is available on our website.

The Pluto S20 and Pluto S46 versions are safety PLC's that are designed for safety and protection products installed locally on a machine. With a wide range of connectivity options, a lot of protection is integrated into a PLC which in turn controls, for example, one or more safe outputs in a qualified manner without risking a dangerous situation.

Using an expansion relay, such as BT50, the number of safe outputs in Pluto can be expanded. The connection will then be made as shown in the figure. If IDFIX PROG is used for single-Pluto, there is the option of copying a PLC program via the identification circuit over to Pluto without having to connect a computer.

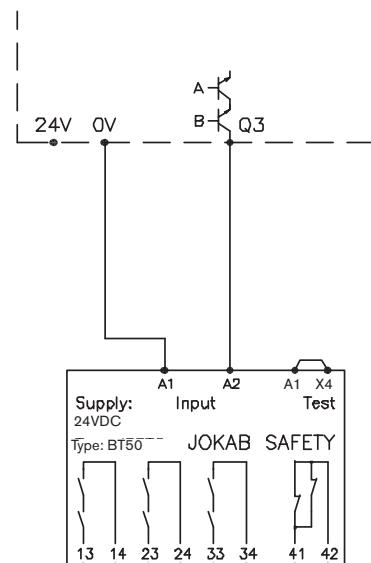



Connection example of a contact expansion with Pluto

Technical data - general	
Manufacturer:	ABB AB/Jokab Safety, Sweden
Colour:	Grey
Operating voltage:	24V DC $\pm$ 15%
Installation:	35 mm DIN rail
Electrical insulation:	Category II in accordance with IEC 61010-1
Level of safety: EN 954-1 EN ISO 13849-1 EN 61508 EN 62061	Kat. 4 PL e/kat. 4 SIL 3 SIL 3
PFH <sub>d</sub> Relay output Transistor output	2,00×10 <sup>-9</sup> 1,50×10 <sup>-9</sup>
Type:	+24 V (for PNP sensors), IQ also configurable as non-failsafe outputs
Current at 24 V Max. overvoltage	5.1 mA 27 V continuous
Safe outputs Q Q2–Q3: Output voltage tolerance  Q0, Q1, (Q4, 5):	Transistor, –24VDC, 800 mA Supply voltage - 1,5 V at 800 mA Relay outputs AC-1: 250 V/1,5 A AC-15: 250 V/1,5 A DC-1: 50 V/1,5 A DC-13: 24 V/1,5 A
Non-failsafe outputs Q Type:	Transistor +24V, PNP "open collector" also configurable as failsafe inputs
Max. current/output:	800 mA

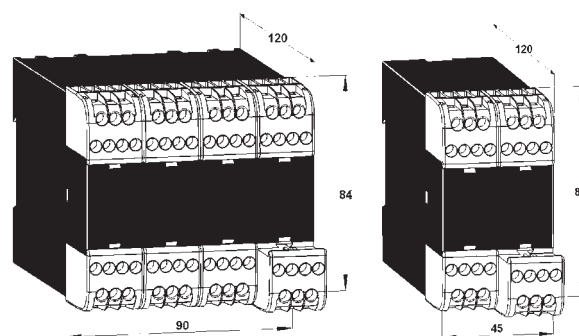
<b>Temperature</b> Ambient temperature: Storage and transport:	–10°C to +50°C –25°C to +55°C
<b>Response times</b> Dyn. A or static input to relay output: Dyn. A or static input to transistor output: Dyn. B or Dyn. C input to relay output: Dyn. B or Dyn. C input to transistor output: Software setting "NoFilt".	<20.5 ms + program exec. time <16.5 ms + program exec. time <23 ms + program exec. time <19 ms + program exec. time 5 ms shorter response time on I & IQ inputs
<b>Additional Response times</b> Databus between Pluto units Databus between Pluto units on error	10 ms 10–40 ms
<b>Enclosure classification</b> Enclosure: Connection terminals:	IP 40, IEC 60 529 IP 20, IEC 60 529

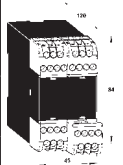

The terminal blocks are detachable without needing to disconnect the wiring. The units are assembled with a gap of at least 5 mm.

Technical data - type-specific		
	<b>Pluto S20</b> 20 I/O Non-Pluto safety bus	<b>Pluto S46</b> 46 I/O Non-Pluto safety bus
Article number/ordering data:	2TLA020070R0500	2TLA020070R1800
Failsafe inputs	8 (I0..I7)	24 (I0..I7, I30..37, I40..I47)
Failsafe inputs or non-failsafe outputs	8 (IQ10..IQ17) Max total load 2.5 A	16 (IQ10..IQ17) (IQ20..IQ27) Max. total load 2A
Analogue inputs	1 (I5) 0..27V	3 (I5) 0..27 V
Failsafe relay outputs	2 (Q0..Q1)	4 (Q0..Q1 & Q4..Q5)
Failsafe transistor outputs	2 (Q2..Q3)	2 (Q2..Q3)
Current monitoring	–	–
Pluto safety bus	–	–
Own current consumption	100...300 mA	100...500 mA
Recommended external fuse:	6 A	10A
Dimensions (w x h x d)	45 x 84 x 118 mm	90 x 84 x 118 mm

## I/O Overview - Pluto without a safety bus

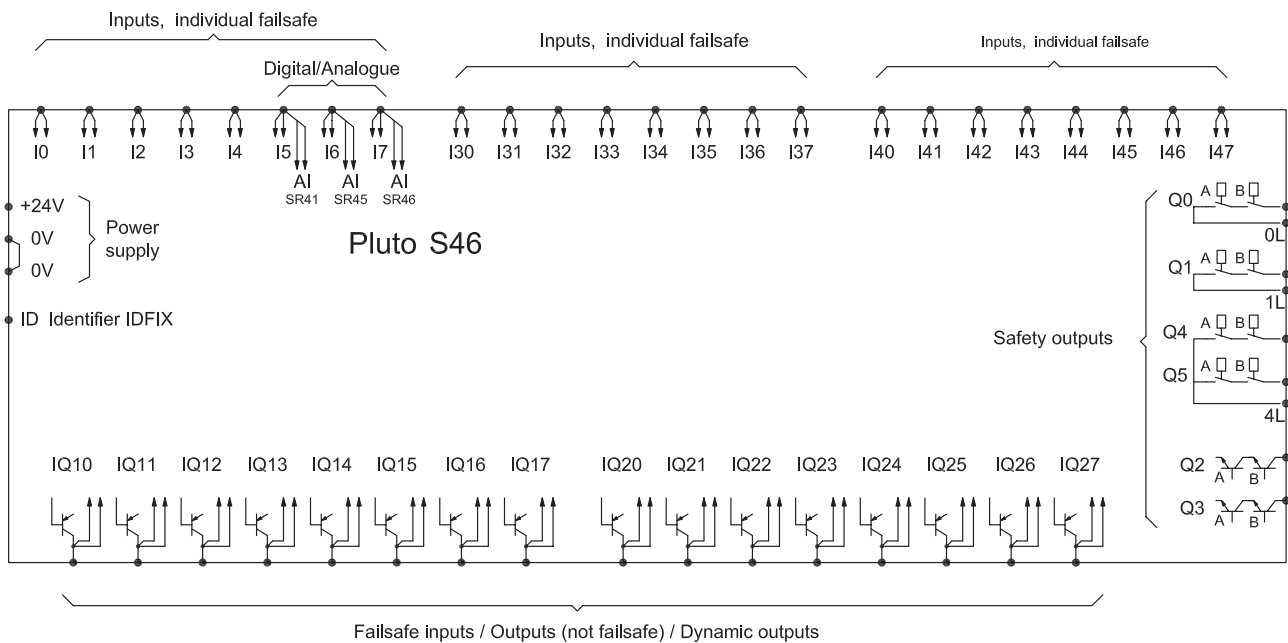
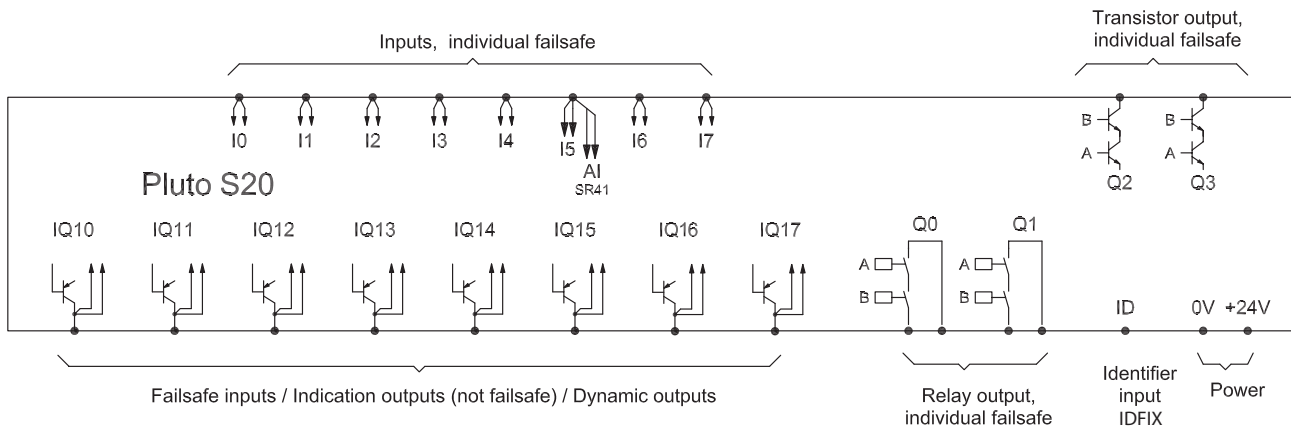

- ID: Connection for identifier, which has a unique ID number that can be read by the system.
- I.. Safety inputs (24 VDC) that are individually secure. This means that the highest level of safety can be achieved with only one input if ABB Jokab Safety dynamic safety components are used. Otherwise two inputs are required for each safety function.
- IQ.. I/O that can be used for safety inputs or signal outputs, e.g. to indicate or control functions that are not safety-related. For IQ.. as safety inputs, refer to I..
- Q0, Q1: Failsafe relay outputs that are individually failsafe and individually programmable.
- Q2, Q3: Failsafe transistor outputs (-24 VDC) that are individually failsafe and individually programmable. Intended for electro-mechanical components such as contactors and valves.
- Q4, Q5: Failsafe relay outputs with common potential that are individually failsafe and individually programmable.





## Pluto with a safety bus

**Pluto models with a safety bus controls and monitors safety for dispersed systems – large as well as small systems.**

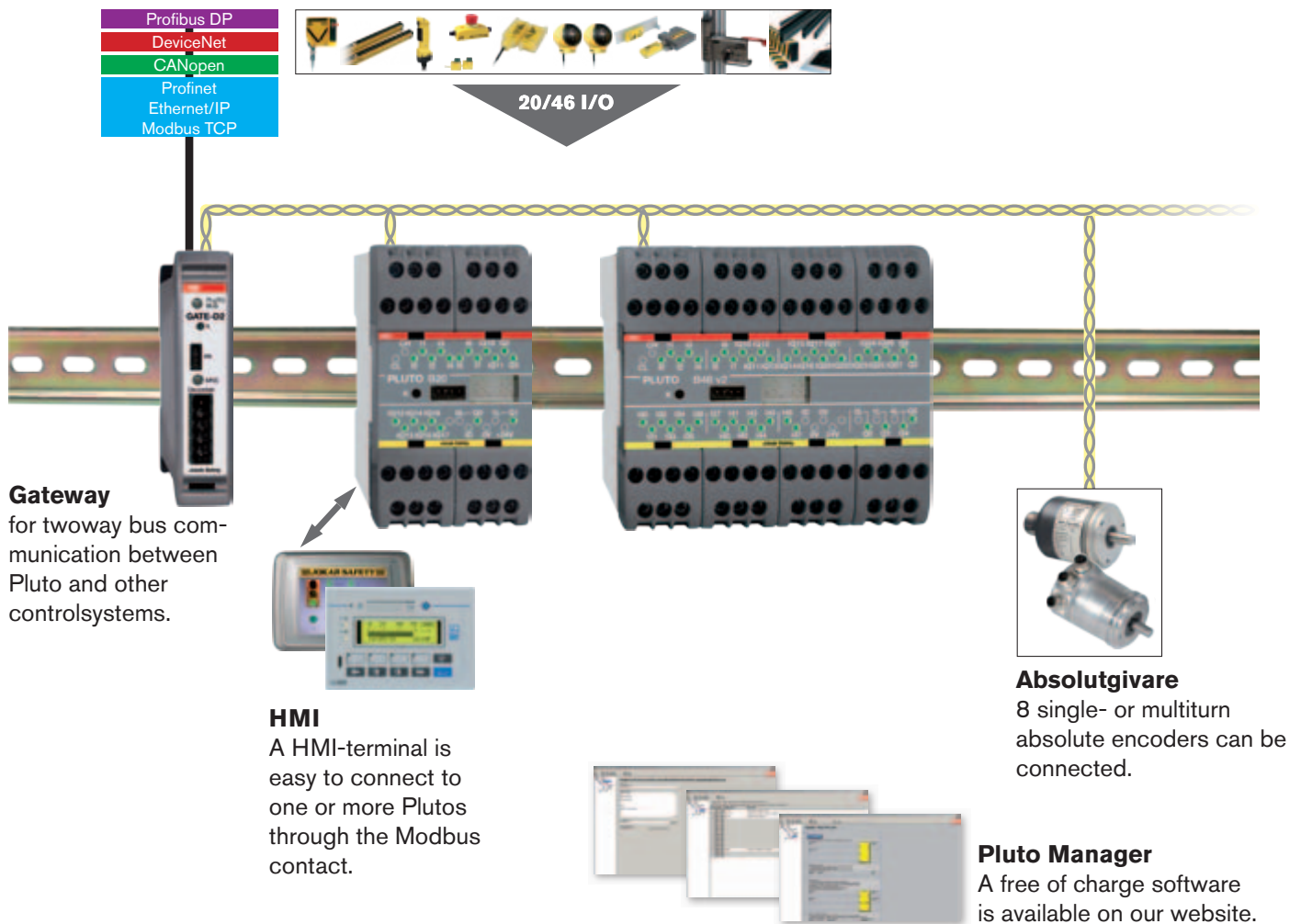

Pluto versions with bus have the same properties as single-Pluto unlike bus communication. With the help of the Pluto-bus networks can be created with multiple Plutos in interaction. Gateways can be connected to the Pluto bus for communication with other systems. The gateway models GATE D2 and C2 can also be used as an extension of the bus cable to extend the Pluto network. The fact that Pluto is an All-master system means that each Pluto device controls its outputs locally, while it is just as easy to read the inputs of other Pluto-units as it is to read its own. It is also easy to both read and write to global memory locations available across the Pluto bus. The PLC program is created using the Pluto Manager freeware and is distributed to all Pluto units. You can also connect speed and position sensors via the Pluto bus.

### Current monitoring (Pluto A20 only)



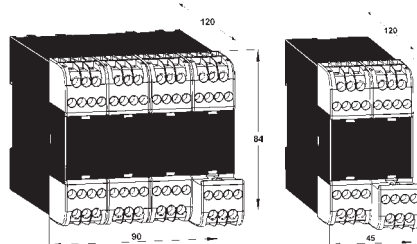

Pluto A20 can monitor the current through the IQ16 and IQ17 outputs. The function is designed for, but not limited to, ensuring that the muting lamps are working. The hardware for current monitoring is not designed with individual redundancy, which means that the function must be used dynamically if it is to be used in a safety function. This means that the current must be read and evaluated both when the output is enabled and disabled.

Technical data - general	
Manufacturer:	ABB AB/Jokab Safety, Sweden
Colour:	Grey
Operating voltage:	24V DC ±15%
Installation:	35 mm DIN rail
Electrical insulation:	Category II in accordance with IEC 61010-1
Safety level EN 954-1 EN ISO 13849-1 EN 61508 EN 62061	Kat. 4 PL e/kat. 4 SIL 3 SIL 3
PFH <sub>d</sub> Relay output Transistor output	2,00×10 <sup>-9</sup> 1,50×10 <sup>-9</sup>
Failsafe inputs I & IQ Type:	+24 V (for PNP sensors), IQ also configurable as non-failsafe outputs
Current at 24 V Max. overvoltage	5.1 mA 27 V continuous
Safe outputs Q Q2–Q3: Output voltage tolerance	Transistor, –24VDC, 800 mA Supply voltage - 1,5 V at 800 mA
Q0, Q1, (Q4, 5):	Relay outputs AC-1: 250 V/1,5 A AC-15: 250 V/1,5 A DC-1: 50 V/1,5 A DC-13: 24 V/1,5 A
Non-failsafe outputs Q Type:	Transistor +24V, PNP "open collector" also configurable as failsafe inputs
Max. current/output:	800 mA

<b>Pluto safety bus</b> Max number of Pluto units on the databus: Databus type: Databus speeds:  Databus cable length:	32 CAN 100, 125, 200, 250, 400, 500, 800, 1000 kb/s Up to 600 m, 150 m at 400 kb/s
<b>Temperature</b> Ambient temperature: Storage and transport:	–10°C to +50°C –25°C to +55°C
<b>Response times</b> Dyn. A or static input to relay output: Dyn. A or static input to transistor output: Dyn. B or Dyn. C input to relay output: Dyn. B or Dyn. C input to transistor output: Software setting "NoFilt".	<20.5 ms + program exec. time <16.5 ms + program exec. time <23 ms + program exec. time <19 ms + program exec. time 5 ms shorter response time on I & IQ inputs
<b>Additional Response times</b> Databus between Pluto units Databus between Pluto units on error	10 ms 10–40 ms
<b>Enclosure classification</b> Enclosure: Connection terminals:	IP 40, IEC 60 529 IP 20, IEC 60 529

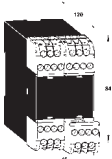

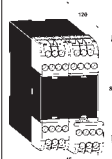
The terminal blocks are detachable without needing to disconnect the wiring. The units are assembled with a gap of at least 5 mm.

Technical data - type-specific				
	<b>Pluto A20</b> 20 I/O <i>Current monitoring</i>	<b>Pluto B16</b> 16 I/O <i>Non-failsafe outputs</i>	<b>Pluto B20</b> 20 I/O	<b>Pluto B46</b> 46 I/O
Article number/ ordering data:	2TLA020070R0300	2TLA020070R0700	2TLA020070R0600	2TLA020070R1700
Failsafe inputs	8 (I0..I7)	8 (I0..I7)	8 (I0..I7)	24 (I0..I7, I30..37, I40..I47)
Failsafe inputs or non-failsafe outputs	8 (IQ10..IQ17) Max total load 2.5 A	8 (IQ10..IQ17) Max total load 2.5 A	8 (IQ10..IQ17) Max total load 2.5 A	16 (IQ10..IQ17) (IQ20..IQ27) Max. total load 2A
Analogue inputs	1 (I5) 0..27V	1 (I5) 0..27V	1 (I5) 0..27V	3 (I5) 0..27 V
Failsafe relay outputs	2 (Q0..Q1)	–	2 (Q0..Q1)	4 (Q0..Q1 & Q4..Q5)
Failsafe transistor outputs	2 (Q2..Q3)	–	2 (Q2..Q3)	2 (Q2..Q3)
Current monitoring	2(IQ16,IQ17)0-1.0A ±10%	–	–	–
Pluto safety bus	▪	▪	▪	▪
Own current consumption	100...300 mA	100...300 mA	100...300 mA	100...500 mA
Recommended external fuse:	6 A	6 A	6 A	10A
Dimensions (w x h x d)	45 x 84 x 118 mm	45 x 84 x 118 mm	45 x 84 x 118 mm	90 x 84 x 118 mm

## I/O Overview - Pluto with a safety bus

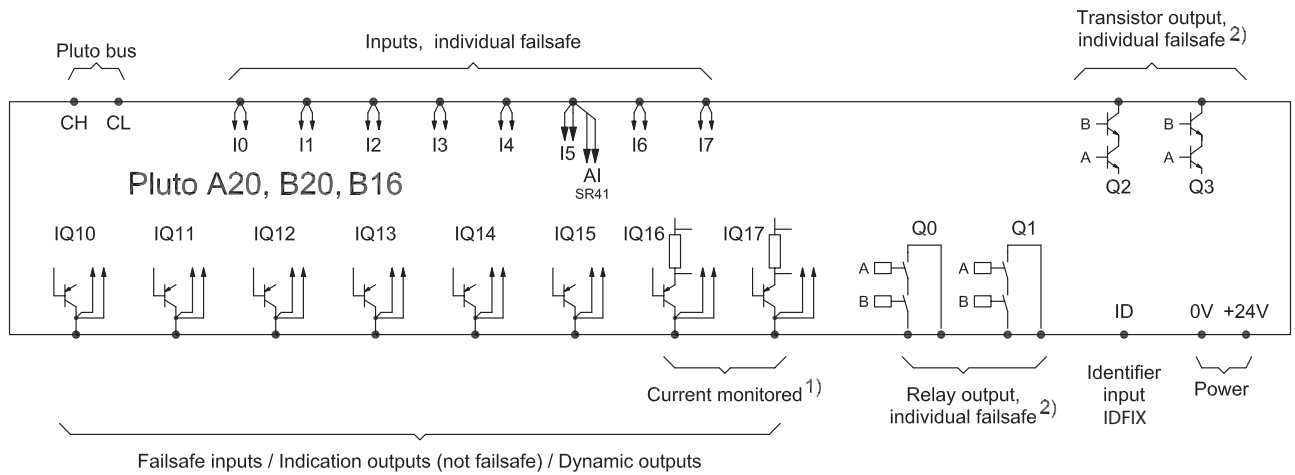

- 1) Current monitored only on A20  
 2) Not in B16

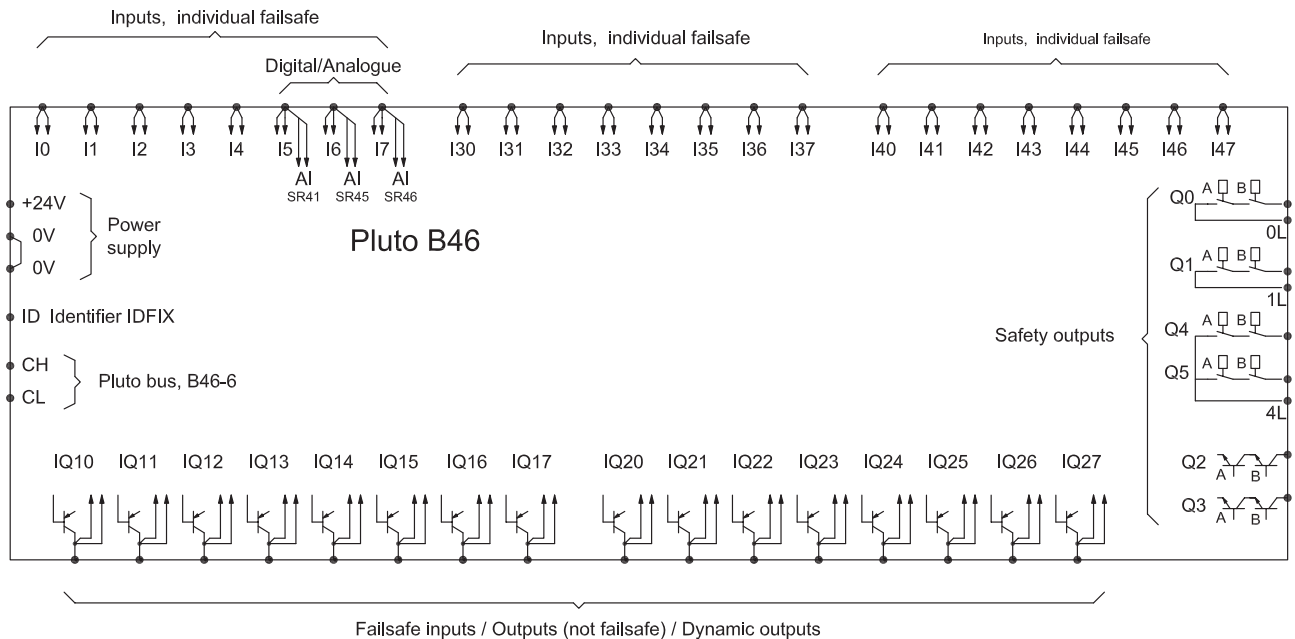

- ID:** Connection for identifier, which has a unique ID number that can be read by the system.
- I..** Safety inputs (24 VDC) that are individually secure. This means that the highest level of safety can be achieved with only one input if ABB Jokab Safety dynamic safety components are used. Otherwise two inputs are required for each safety function.
- IQ..** I/O that can be used for safety inputs or signal outputs, e.g. to indicate or control functions that are not safety-related. For IQ.. as safety inputs, refer to I..
- Q0, Q1:** Failsafe relay outputs that are individually failsafe and individually programmable.
- Q2, Q3:** Failsafe transistor outputs (-24 VDC) that are individually failsafe and individually programmable. Intended for electro-mechanical components such as contactors and valves.
- Q4, Q5** Failsafe relay outputs with common potential that are individually failsafe and individually programmable.

 TÜVRheinland®

**ZERTIFIKAT**      **EC Type-Examination Certificate**  
**CERTIFICATE**      **Reg.-No.: 01/205/5066/10**

<b>Product tested</b>	Logic unit to ensure safety functions Safety PLC	<b>Certificate holder</b>	ABB AB Jakob Safety Regelgatan 3 213 76 Malmö Sweden
<b>Type designation</b>	Pluto	<b>Manufacturer</b>	see certificate holder
<b>Causes and standards forming the basis of testing</b>	EN ISO 13049-1:2008 + AC:2009 EN 62061:2005 IEC 61508 Parts 1-7:1998 / 2000 EN 62004-1:2005 + A1:2009 (in extracts)	EN 6178:1997 EN 61496-1:2005 + A1:2006 (in extracts) EN 574:1996 + A1:2006 (in extracts)	
<b>Intended application</b>	Safety related programmable electronic systems for machinery and process industry applications  The Pluto PLC complies with the requirements of the relevant standards (Cat. 4 / PL, e acc. to EN ISO 13049-1, SIL, CL, 3 acc. to EN 62061 / IEC 61508, Type IEC of EN 574, Type 4 of EN 61496-1) and can be used in applications up to Cat. 4 / PL, e acc. to EN ISO 13049-1 and SIL 3 acc. to EN 62061 / IEC 61508.		
<b>Specific requirements</b>	The current "Version Release List" as well as the conditions defined in the Programming Manual, Safety Manual and the Operating Instructions must be considered.		
It is confirmed, that the product under test complies with the requirements for machines defined in Annex I of the EC Directive 2006/42/EC.			
This certificate is valid until 2015-11-19.			



The test report no. 5066/10 dated 2010-11-19 is an integral part of this certificate.

The holder of a valid license certificate for the product tested is authorized to affix the FS mark shown opposite to products, which are identical with the product tested.



Berlin, 2010-11-19

Certified (PLC) for Machinery, NR 0035      Ing.-Ing. Stephan Fiebig

 TÜV NORD

**EG-Baumusterprüfbescheinigung**  
 EC type-examination certificate

**Registrier-Nr.**  
 Registrier-Nr.:  
**44 205 11 300992 000**

<b>Zustellen des Auftragsgebers</b> Customer's reference	<b>Auftragdatum</b> Date of order 15.12.2010	<b>Akzeptanzform</b> File reference 000210002	<b>Prüfbericht Nr.</b> Test report no. 11 205 300992 000
<b>Name und Anschrift des Auftragsgebers</b>	<b>ABB AB</b> Jakob Safety Varförsvägen 11 434 39 Kungälv Sweden		<b>Kunden's name and address</b>

Erhält mit dem u. g. Produkt die Anforderungen des Anhangs I der Maschinenrichtlinie 2006/42/EG als neue Baubestimmung für die EG-Konformitätsbewertung.  
 The product described below meets the requirements of Annex I of the Directive 2006/42/EC as a basis for the CE declaration of conformity.

<b>Geprüft nach</b>	<b>Maschinenrichtlinie 2006/42/EG</b> Machinery Directive 2006/42/EC	<b>Tested in accordance with</b>
<b>Beschreibung des Produktes</b> (Details siehe Anlage 1)	Safe input drive for bus system "ASi Safety at Work"	<b>Description of product</b> (Details see annex 1)
<b>Typenbezeichnung</b>	<b>URAX ...</b>	<b>Type Description</b>
<b>Serial-Nr.</b>	siehe Anlage 1 see annex 1	<b>Serial no.</b>
<b>Normung</b>	EN 61508 / EN 62061, SIL 3, PFD = 10 <sup>-9</sup> EN ISO 13049-1, pl "a"	<b>Marking</b>

Bitte beachten Sie auch die unvermeidlichen Hinweise.  
 Please also pay attention to the information noted overhead!

TÜV NORD CERT GmbH  
 Zertifizierungsstelle / Certification for Machinery / Machinery  
 Besondere Prüfstelle (BPA) / Special Office (SOA)

Gültig bis / Valid to: 02.02.2016  
 Hannover, 02.02.2011

Lehrbergstr. 20 • 47699 Essen • Fax +49 (0)201 833 9130 • Fax +49 (0)201 833 2030 • Email: machinen@tuv-nord.de

 CSA INTERNATIONAL

**Certificate of Compliance**

<b>Certificate:</b> 1700339	<b>Master Contract:</b> 185438
<b>Project:</b> 1933410	<b>Date Issued:</b> 2008/01/25
<b>Issued to:</b> Jakob Safety AB Regelgatan 3 Malmö, 213 76 Sweden	

*The products listed below are eligible to bear the CSA Mark shown with adjacent indicators 'C' and 'US'*



Issued by: David Deppay, T.P.

Authorized by: Helene Valléevean, Operations Manager

Helene Valléevean

**PRODUCTS**

- CLASS 1252 R1 - PROCESS CONTROL EQUIPMENT - Certified to US Standards
- CLASS 1252 S3 - PROCESS CONTROL EQUIPMENT - Components
- CLASS 1252 R3 - PROCESS CONTROL EQUIPMENT - Certified to US Standards
- CLASS 3211 R7 - INDUSTRIAL CONTROL EQUIPMENT - Miscellaneous Apparatus

Component type? Programmable Logic Controller, permanently installed rail mounted, Models: PLUTO A/0, PLUTO I/0, PLUTO S/0, PLUTO A/6, PLUTO B/6, PLUTO B/6-6, PLUTO S/6-6 and PLUTO AS-4, rated output: 24Vdc, 5A (max), rated output: 24Vdc, 800mA / 2-3A max total load all outputs (R310-R317) (RQ30-77) and 250Vvac, 1.5A (R04-Q104-Q5), -24Vdc, 300mA (QE-Q3), IP40, IP70 terminals.

The 'C' and 'US' indicators adjacent to the CSA Mark signify that the product has been evaluated to the applicable CSA and UL/ETL Standards for use in Canada and the U.S., respectively. The 'C' indicator indicates products eligible to bear the NRTL, UL, or ETL National Recognized Testing Laboratory, as a designation granted by the U.S. Department of Safety and Health Administration (DHS) to laboratories which have been accepted to perform evaluations on U.S. Standards.

Issued for file: 1700339

## Robot cell with Pluto

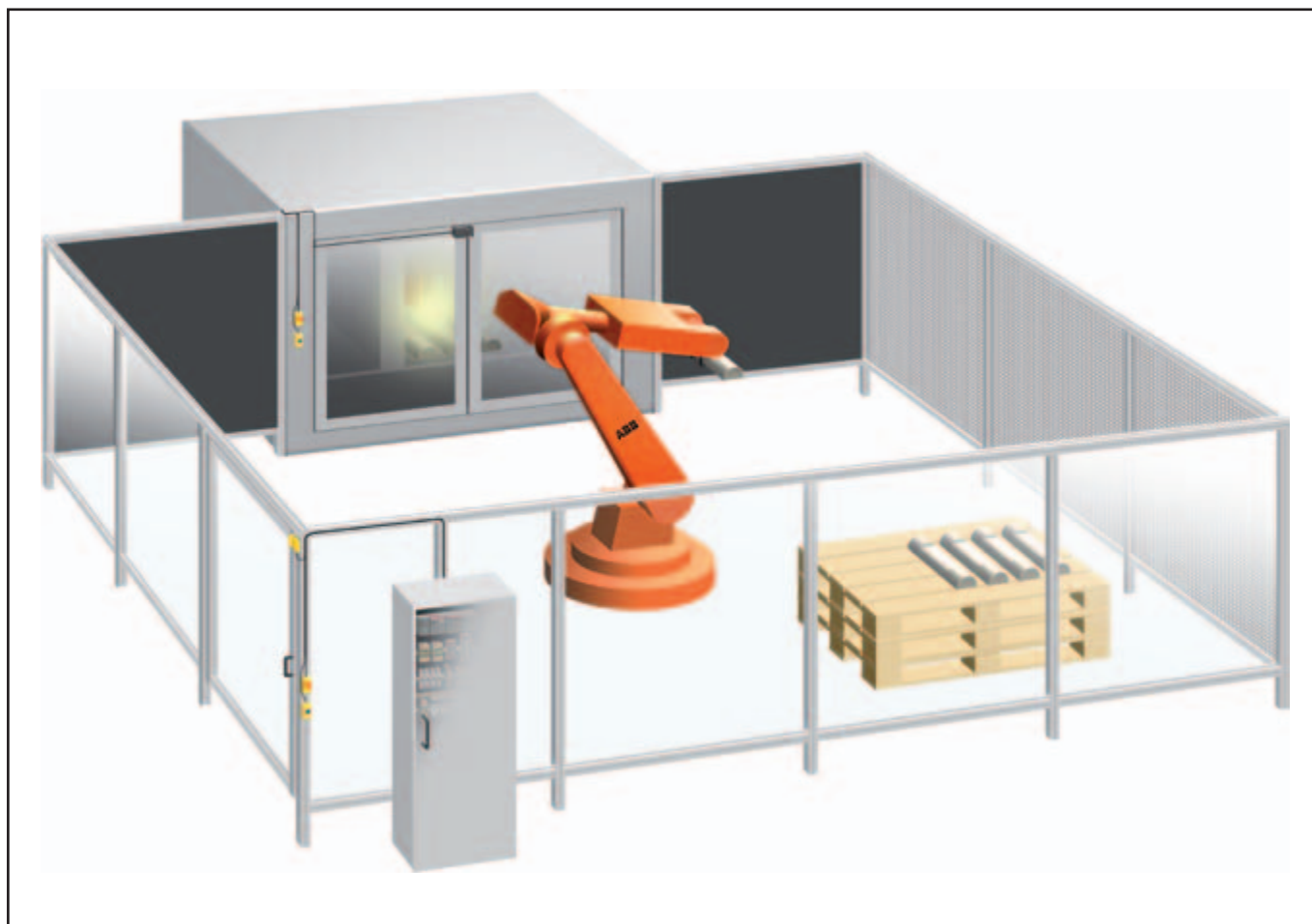

### Description:

The example describes a processing machine served by a robot. The machine safety system consists of one (Pluto 1) to which all protection has been connected. The robot has been equipped with a (Pluto 0) to which the cell protection has been connected. The Pluto for the machine has been connected via a databus cable to the robot's Pluto so that common functions, such as emergency stop, can be used by the whole cell.

### Function:

Emergency stop takes priority and will stop both the machine and the robot. The machine hatch acts as the zone divider, when the hatch is closed the machine forms one zone and the robot another zone. When the machine hatch is open, both the machine and the robot belong to the same zone. If the door is opened when the machine hatch is open, the machine and the robot will both stop, but if the machine hatch is closed, only the robot will be stopped. After the door has been opened, the system must be reset by means of the reset button on the outside of the door. Emergency stop is reset when the pressed-in button is pulled out. NOTE. The cell operating cycle must not however start immediately on resetting the emergency stop or the door.



# Electrical connections

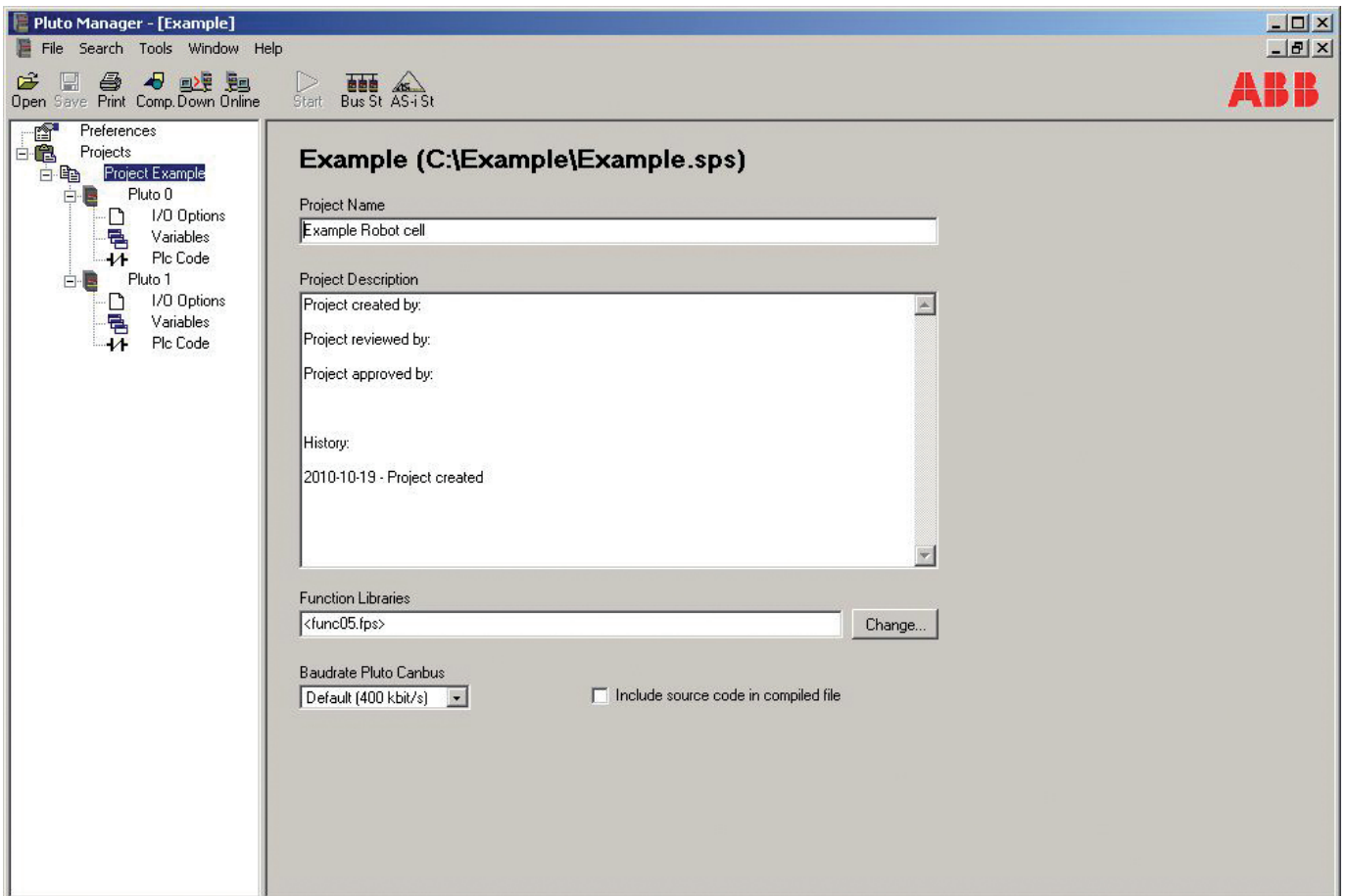
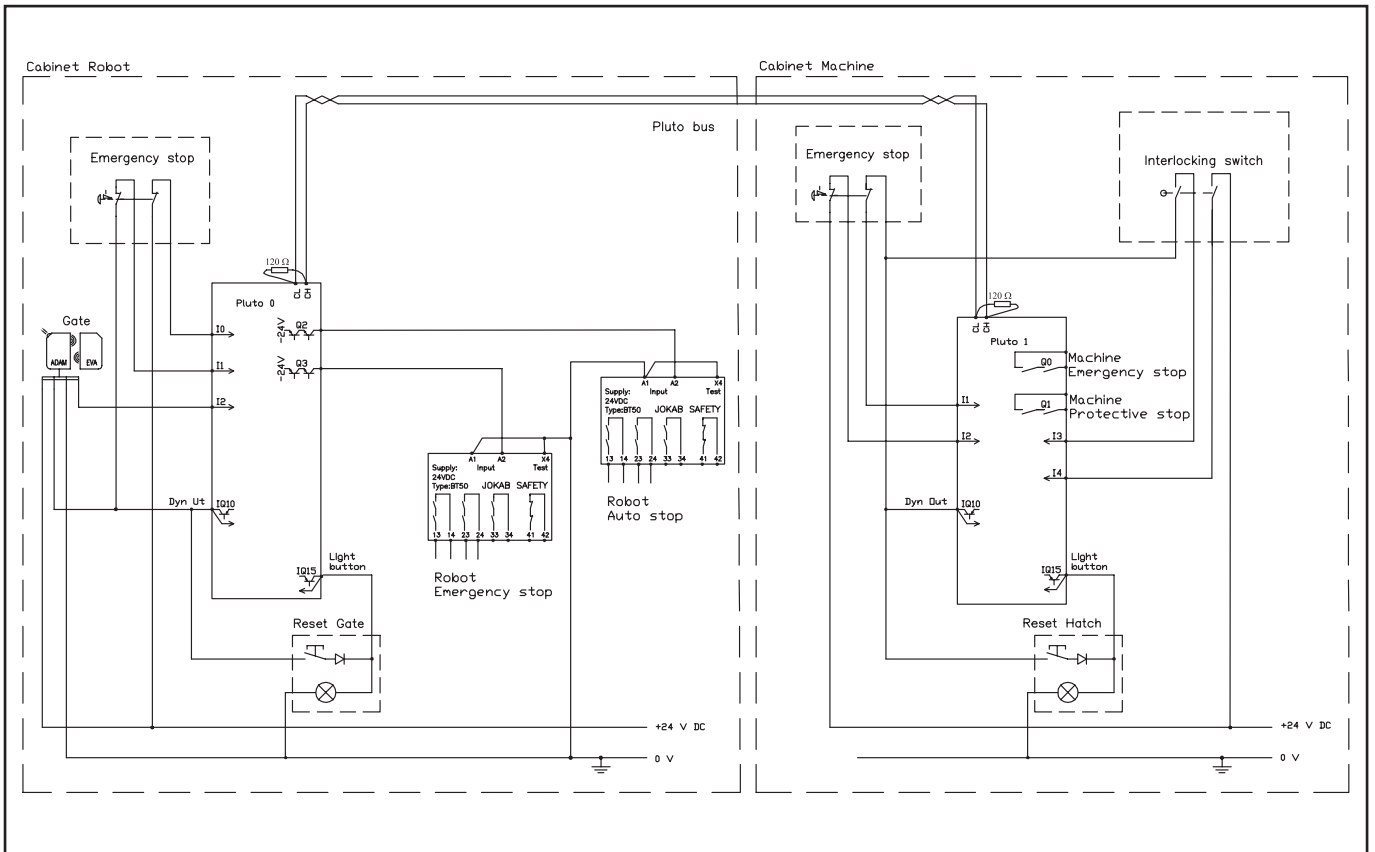

## Pluto 0 settings – Robot cabinet



### Pluto 0

IO0.0=P0\_ES1\_Ch1  
 IO0.1=P0\_ES1\_Ch2  
 IO0.2=P0\_Eden1  
 IO0.15=P0\_LB1\_In  
 Q0.2=P0\_AS\_OK  
 Q0.3=P0\_ES  
 GM0.0=P0\_ES\_OK

;Emergency stop 1 channel 1 - Static  
 ;Emergency stop 1 channel 2 - Dynamic A non-inverted  
 ;Door Eden sensor - Dynamic A  
 ;Reset Door - Light button input - Dynamic A  
 ;Robot auto stop - Expansion BT50 relay  
 ;Robot emergency stop - Expansion BT50 relay  
 ;Emergency stop OK in Pluto 0

## Pluto 1 settings – Machine cabinet

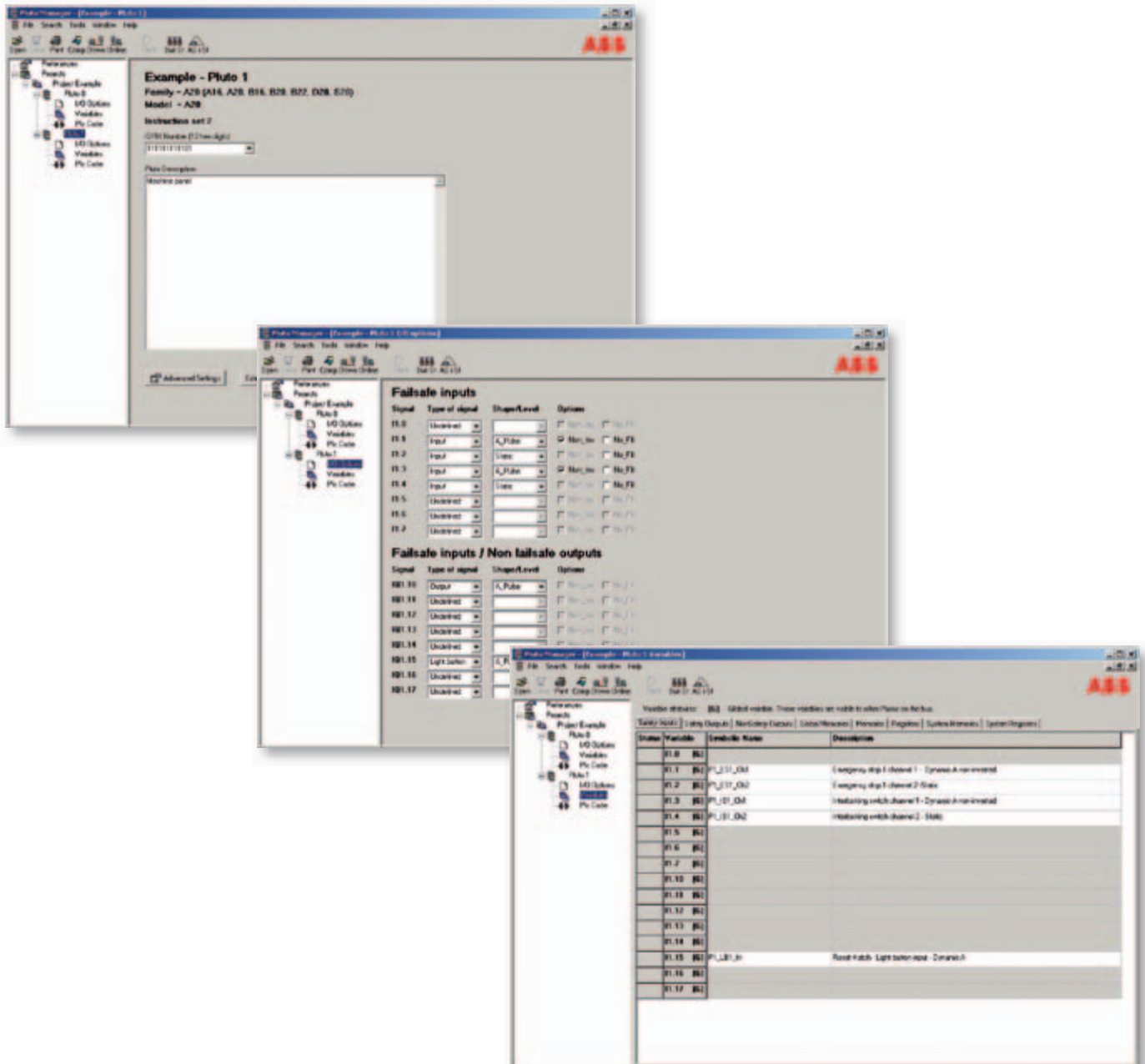

### Pluto 1

I1.1=P2\_ES1\_Ch1

;Emergency stop 1 channel 1 - Dynamic A non-inverted

I1.2=P2\_ES1\_Ch2

;Emergency stop 1 channel 2 -Static

I1.3=P2\_IS1\_Ch1

;Interlocking switch channel 1 - Dynamic A non-inverted

I1.4=P2\_IS1\_Ch2

;Interlocking switch channel 2 - Static

I1.15=P2\_LB1\_In

;Reset Hatch - Light button input - Dynamic A

Q1.0=P2\_ES

;Machine Emergency stop

Q1.1=P2\_PS

;Machine protective stop

GM1.0=P2\_ES\_OK

;Emergency stop OK in Pluto 1

GM1.1=P2\_Hatch\_OK

;Hatch closed

## PLC code Pluto 0 – Robot cabinet

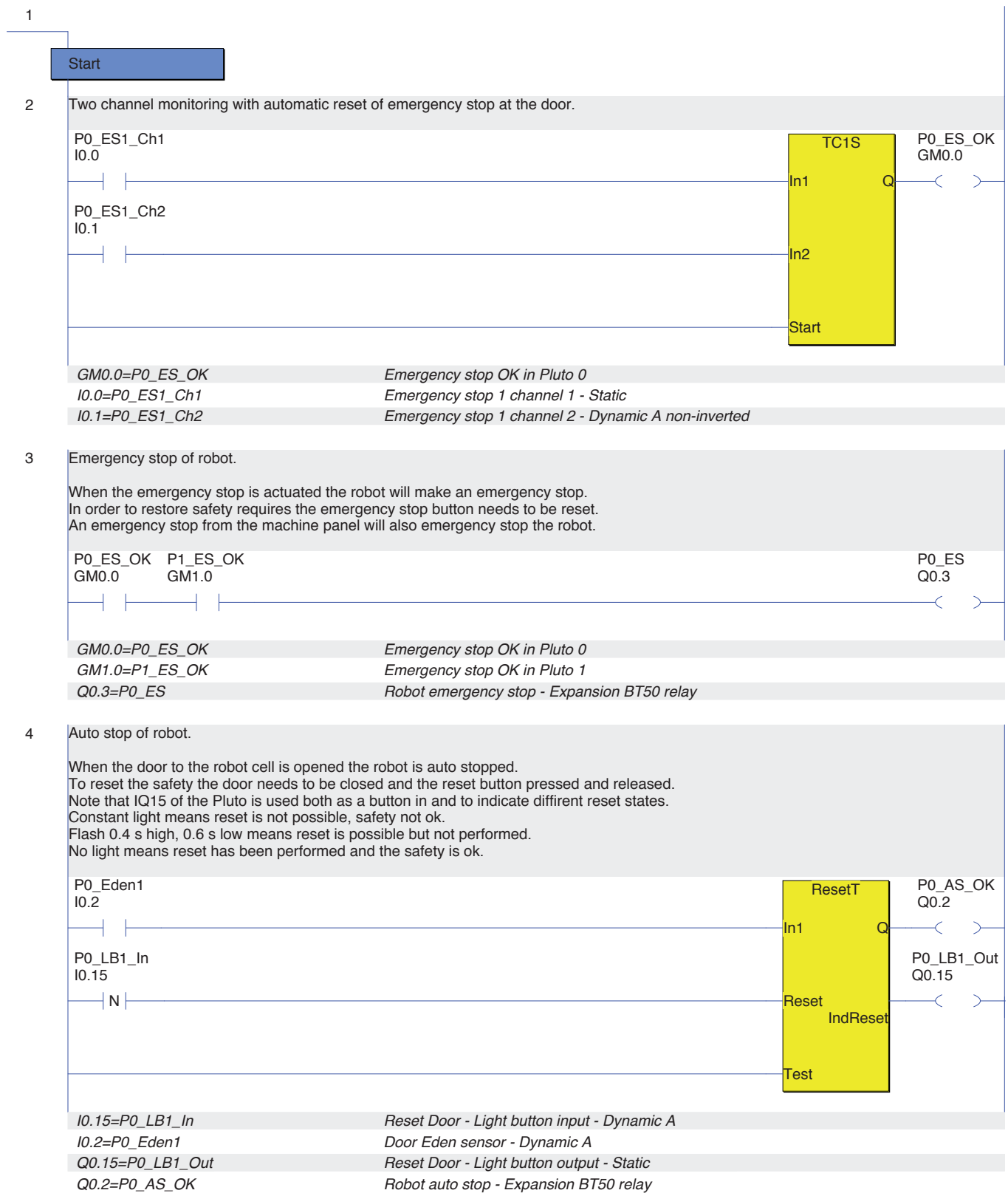

5 Alarm 03 - Machine hatch open.

To generate User Errors (UE) a value of 200 - 299 can be written to the display of the Pluto.  
A check of System Register 11 (SR11) in the Pluto prioritises errors from the Pluto itself over User Errors.

P1\_Hatch\_OK GM1.1    P0\_AS\_OK Q0.2    SR\_ErrorCode=0 SR0.11=0    SR\_PlutoDisplay=203 SR0.10=203



GM1.1=P1\_Hatch\_OK                      Hatch closed  
Q0.2=P0\_AS\_OK                            Robot auto stop - Expansion BT50 relay  
SR0.10=SR\_PlutoDisplay                Pluto display figure. For user error: 200+no  
SR0.11=SR\_ErrorCode                    Error code

6 Alarm 02 - Door open.

To generate User Errors (UE) a value of 200 - 299 can be written to the display of the Pluto.  
A check of System Register 11 (SR11) in the Pluto prioritises errors from the Pluto itself over User Errors.

P0\_Eden1 I0.2    SR\_ErrorCode=0 SR0.11=0    SR\_PlutoDisplay=202 SR0.10=202



I0.2=P0\_Eden1                            Door Eden sensor - Dynamic A  
SR0.10=SR\_PlutoDisplay                Pluto display figure. For user error: 200+no  
SR0.11=SR\_ErrorCode                    Error code

7 Alarm 01 - Emergency stop actuated.

To generate User Errors (UE) a value of 200 - 299 can be written to the display of the Pluto.  
A check of System Register 11 (SR11) in the Pluto prioritises errors from the Pluto itself over User Errors.

P0\_ES\_OK GM0.0    SR\_ErrorCode=0 SR0.11=0    SR\_PlutoDisplay=201 SR0.10=201



GM0.0=P0\_ES\_OK                            Emergency stop OK in Pluto 0  
SR0.10=SR\_PlutoDisplay                Pluto display figure. For user error: 200+no  
SR0.11=SR\_ErrorCode                    Error code



## PLC code Pluto 1 – Machine cabinet

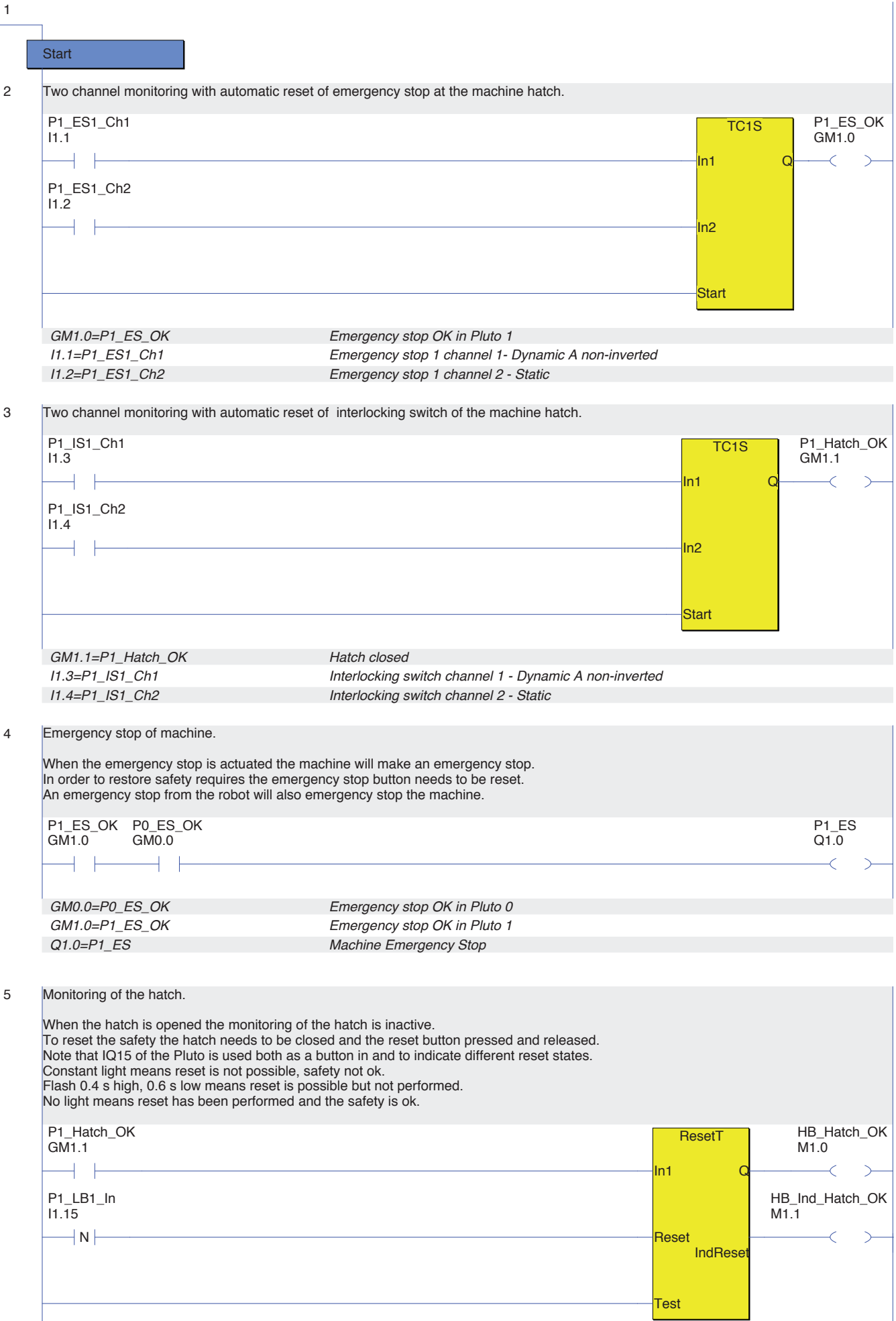

GM1.1=P1_Hatch_OK	Hatch closed
I1.15=P1_LB1_In	Reset Hatch - Light button input - Dynamic A
M1.0=HB_Hatch_OK	Help Bit - Hatch closed
M1.1=HB_Ind_Hatch_OK	Help Bit - Indication Reset Hatch

6 Light button indication of the reset of the hatch.

If the robot cell's door is closed and reset no light indication is needed inside the cell.



7 Protective stop of the machine.

Either the hatch is closed and reset or the door to the robot cell is closed and reset. This means the cell can work with the hatch both open or closed as long as the cell's door is closed and reset.

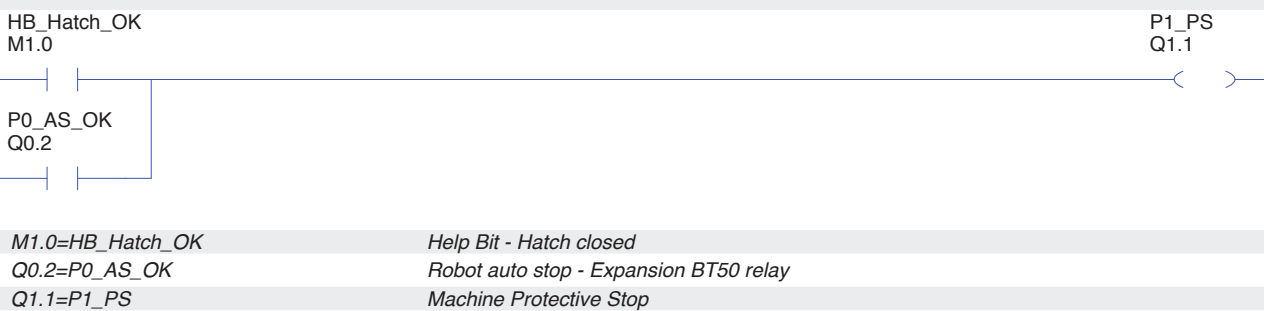

8 Alarm 03 - Machine hatch open.

To generate User Errors (UE) a value of 200 - 299 can be written to the display of the Pluto. A check of System Register 11 (SR11) in the Pluto prioritises errors from the Pluto itself over User Errors.

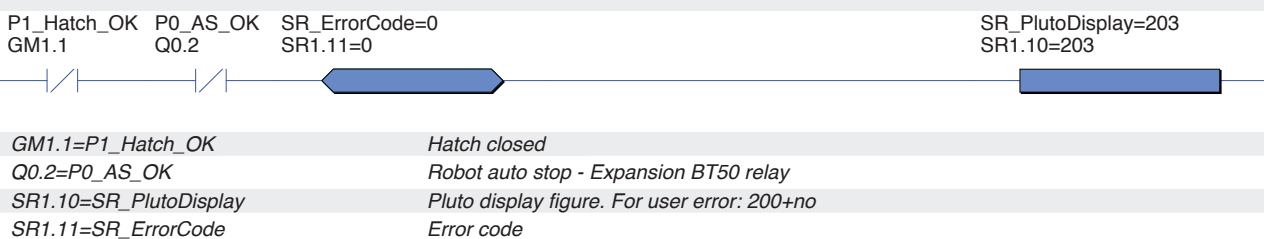

9 Alarm 02 - Door open.

To generate User Errors (UE) a value of 200 - 299 can be written to the display of the Pluto. A check of System Register 11 (SR11) in the Pluto prioritises errors from the Pluto itself over User Errors.

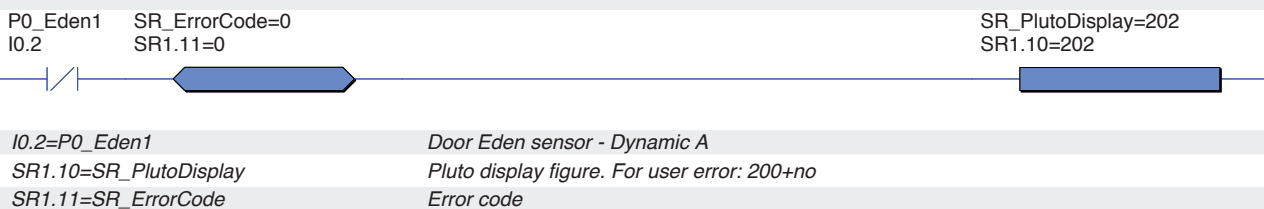

10 Alarm 01 - Emergency stop actuated.

To generate User Errors (UE) a value of 200 - 299 can be written to the display of the Pluto. A check of System Register 11 (SR11) in the Pluto prioritises errors from the Pluto itself over User Errors.

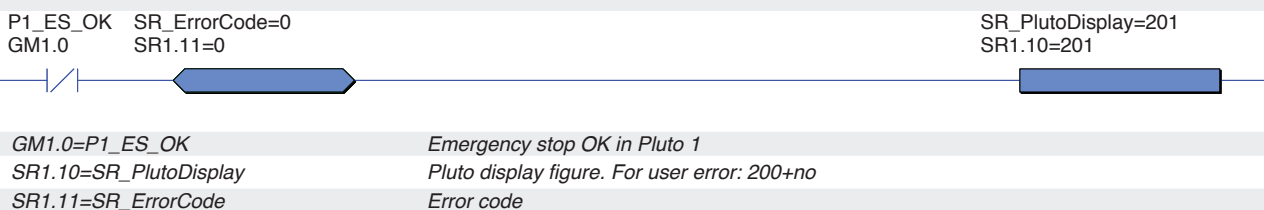

## Pluto gateway

# GATE-P2

### Use:

Bi-directional status information from the Pluto safety PLC

For Profibus

### Features:

Two-way communication

Built-in filter function, shared network

Only 22.5 mm wide

Can be located anywhere in the databus

Common interface with Pluto

Ready-made function blocks

Profibus DP

DeviceNet

CANopen

Profinet

Ethernet/IP

Modbus TCP



Pluto gateway is a unit providing two-way communication between a Pluto safety PLC and other field buses.

The Pluto gateway is a compact unit mounted on a DIN rail, and can be connected anywhere in a Pluto safety bus. The unit has a common interface with Pluto, i.e. the same cabling, and the Pluto Manager PC program can be used for servicing and where necessary programming. Normally, however, all the settings are made via a DIP switches, which means that programming tools are not required to put the gateway itself into operation.

For programming Pluto there are ready-made function blocks which, via a Pluto gateway, send and receive data from the supervisory system.

### Data from Pluto

Via PROFIBUS a supervisory PLC system can have access to the I/O and other variables in a Pluto safety PLC. Global I/O in a Pluto safety PLC are accessible via PROFIBUS modules in the gateway, one module for each Pluto unit. Local data in Pluto units can be read by a "local data" module together with the PLC codes in the supervisory system.

### Data to Pluto

Via PROFIBUS a supervisory PLC system can transmit non-safety-related information to a Pluto safety PLC. A total of 64 Boolean values and 8 different 16-bit registers can be transmitted. Function blocks for these functions are available in Pluto Manager.

### PLC function blocks

To simplify the integration of a Pluto gateway PROFIBUS into the supervisory PLC system, ABB Jokab Safety provides ready-made function blocks for several popular brands of PLC. The function blocks make it easier to receive and send information to the Pluto system. The function blocks are supplied as open units with full access for the customer to change and add functions. These function blocks can be obtained via [www.abb.com/lowvoltage](http://www.abb.com/lowvoltage).



## Technical data - GATE-P2

<b>Manufacturer:</b>	ABB AB/Jokab Safety, Sweden
<b>Article number/ordering data:</b>	2TLA020071R8000 GATE-P2
<b>Databases:</b>	-Pluto safety bus CAN (isolated) -PROFIBUS RS485 (isolated)
<b>Pluto safety bus speeds:</b>	100, 200, 250, 400, 500, 800 and 1000 kbit/s (automatic speed detection)
<b>PROFIBUS speed:</b>	Up to 12 Mbit/s (automatic speed detection)
<b>PROFIBUS address:</b>	Setting via DIP switches (0-99)
<b>PROFIBUS version:</b>	DP slave, DP-V0
<b>Connections:</b>	Top, 3-pole terminal for Pluto safety bus (included) Front, standard 9-pole PROFIBUS connection. Bottom, 2-pole terminal for 24 V DC (included)
<b>Status indication:</b>	Pluto safety bus status indication via LED PROFIBUS status indication via LED
<b>Operating voltage:</b>	24 V DC, -15% till +20%
<b>Current at 24 V:</b>	< 100 mA (recommended fuse ≤ 6 A)
<b>Dimensions (w x h x d):</b>	22.5 x 101 x 119 mm
<b>Installation:</b>	35 mm DIN rail
<b>Operating temperature (ambient):</b>	-10°C to + 55°C
<b>Temperature, transport and storage:</b>	-25°C to + 55°C
<b>Humidity:</b>	EN 60 204-1 50% at 40°C (ambient 90% at 20°C)
<b>Enclosure classification:</b>	Enclosure IP 20 - IEC 60 529 Terminals IP 20 - IEC 60 529

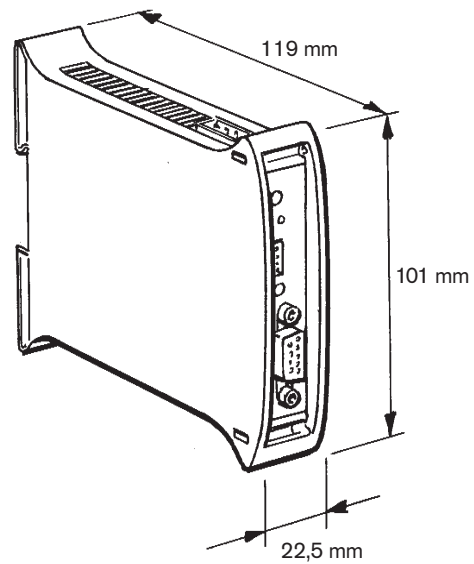

## Gateway block schematic diagram - Pluto Profibus

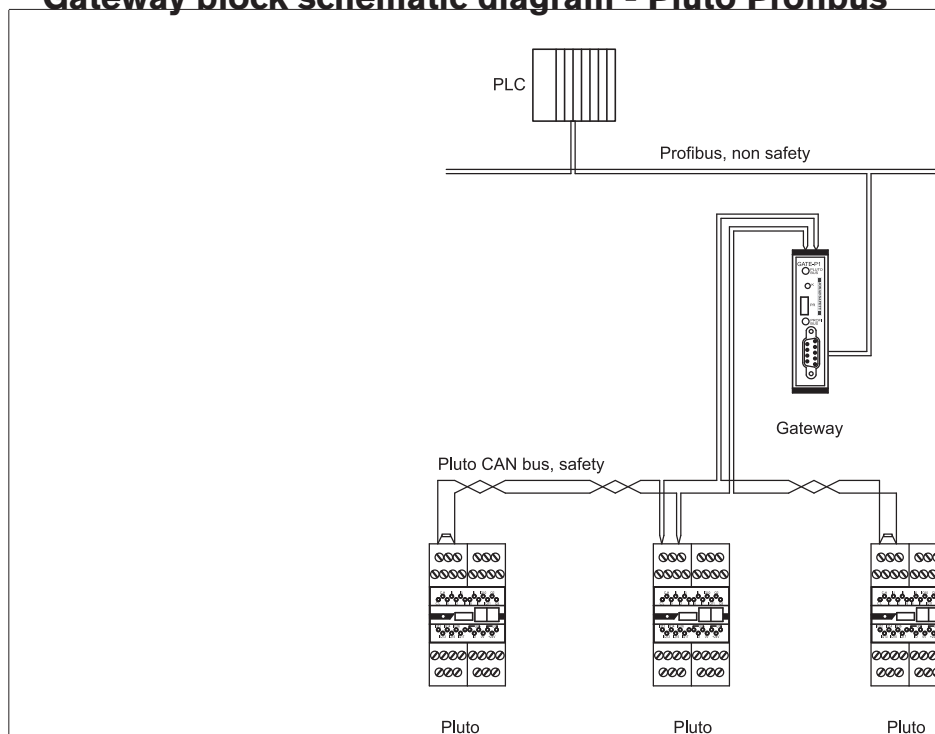

## Pluto gateway

# GATE-D2

### Use:

Bi-directional status information from the Pluto safety PLC

For DeviceNet and Pluto bridge

### Features:

Two-way communication

Built-in filter function, shared network

Only 22.5 mm wide

Can be located anywhere in the databus

Common interface with Pluto

Ready-made function blocks

Profibus DP

DeviceNet

CANopen

Profinet

Ethernet/IP

Modbus TCP



Pluto gateway is a unit providing two-way communication between a Pluto safety PLC and other field buses.

The Pluto gateway is a compact unit mounted on a DIN rail, and can be connected anywhere in a Pluto safety bus. The unit has a common interface with Pluto, i.e. the same cabling, and the Pluto Manager PC program can be used for servicing and where necessary programming. Normally, however, all the settings are made via a DIP switches, which means that programming tools are not required to put the gateway itself into operation.

For programming Pluto there are ready-made function blocks which, via a Pluto gateway, send and receive data from the supervisory system.

### Data from Pluto

Via DeviceNet a supervisory PLC system can have access to the I/O and other variables in a Pluto safety PLC. Global I/Os in a Pluto safety PLC are accessible via DeviceNet "implicit" messages. Local data in Pluto units can be read via DeviceNet "explicit" messages.

### Data to Pluto

Via DeviceNet a supervisory PLC system can transmit non-safety-related information to a Pluto safety PLC. A total of 64 Boolean values and 8 different 16-bit registers can be transmitted (via DeviceNet "implicit" or "explicit" messages). Function blocks for these commands are available in Pluto Manager.

### Pluto bridge

A GATE-D2 can also be used to advantage as a CAN bridge when it is required to divide a Pluto safety bus into

several sections. This is particularly useful when long databus cables are needed.

There is also a built-in filter function which makes it possible to block any data that is not required for use on the other side of the bridge, which reduces the databus loading in the other sections and thereby permits longer databus cables.

### ABB Robotics IRC5

PLUTO GATE-D2 has support for integration into an ABB Robotics IRC5-system. The documentation that describes this integration can be obtained via the [www.abb.com/low-voltage](http://www.abb.com/low-voltage).





Technical data - GATE-D2	
<b>Manufacturer</b>	ABB AB/Jokab Safety, Sweden
<b>Article number/ordering data:</b>	2TLA020071R8200 GATE-D2
<b>Databuses:</b>	-Pluto safety bus CAN (isolated) -DeviceNet CAN (isolated)
<b>Pluto safety bus speeds:</b>	100, 200, 250, 400, 500, 800 and 1000 kbit/s (automatic speed detection)
<b>DeviceNet speeds:</b>	125, 250 and 500 kbit/s (set via DIP switch)
<b>DeviceNet address:</b>	Setting via DIP switches (1-63)
<b>DeviceNet Version:</b>	ODVA version 2.0
<b>Connections:</b>	Top, 3-pole terminal for Pluto safety bus (included) Front, 5-pole terminal for DeviceNet (included) Bottom, 2-pole terminal for 24 V DC (included)
<b>Status indications:</b>	Pluto safety bus status indication via LED DeviceNet MNS status indication via LED
<b>Operating voltage:</b>	24 V DC, -15% till +20%
<b>Current at 24 V:</b>	< 100 mA (recommended fuse ≤ 6 A)
<b>Dimensions (w x h x d):</b>	22.5 x 101 x 119 mm
<b>Installation:</b>	35 mm DIN rail
<b>Operating temperature (ambient):</b>	-10°C to + 55°C
<b>Temperature, transport and storage:</b>	-25°C to + 55°C
<b>Humidity:</b>	EN 60 204-1 50% at 40°C (ambient 90% at 20°C)
<b>Enclosure classification:</b>	Enclosure IP 20 - IEC 60 529 Terminals IP 20 - IEC 60 529

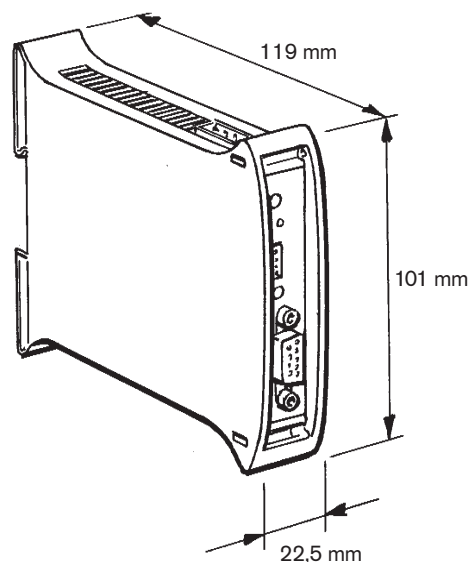

### Gateway block schematic diagram - Pluto DeviceNet

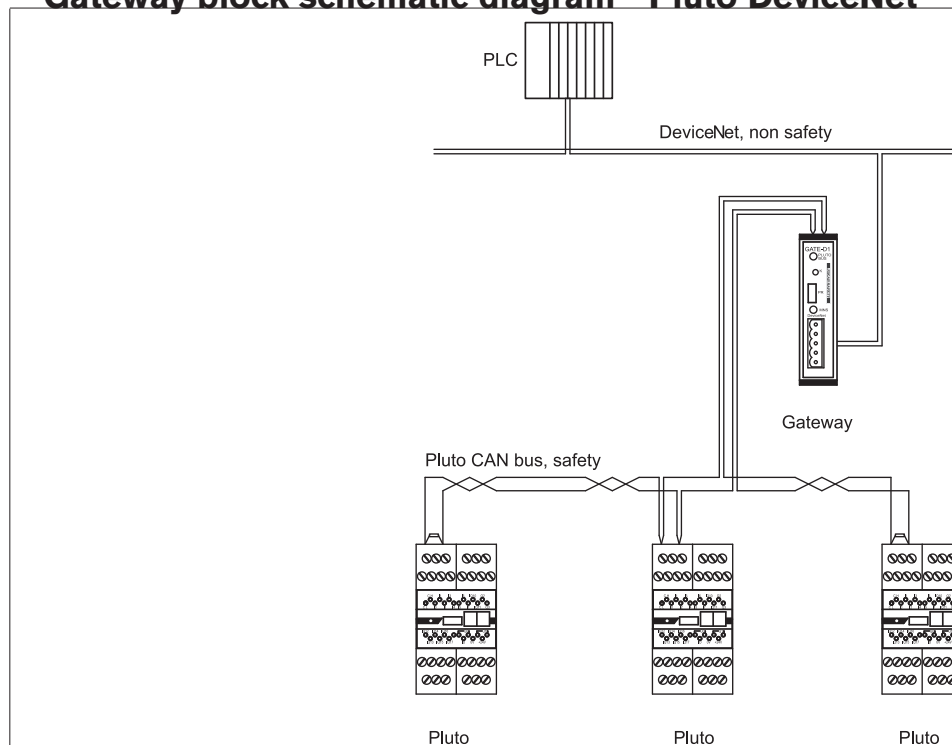

## Pluto gateway

# GATE-C2

### Use:

Bi-directional status information from the Pluto safety PLC

For CANopen and Pluto-bridge

### Features:

Two-way communication

Built-in filter function, shared network

Only 22.5 mm wide

Can be located anywhere in the databus

Common interface with Pluto

Ready-made function blocks

Profibus DP

DeviceNet

CANopen

Profinet

Ethernet/IP

Modbus TCP



Pluto gateway is a unit providing two-way communication between a Pluto safety PLC and other field buses.

The Pluto gateway is a compact unit mounted on a DIN rail, and can be connected anywhere in a Pluto safety bus. The unit has a common interface with Pluto, i.e. the same cabling, and the Pluto Manager PC program can be used for servicing and where necessary programming. Normally, however, all the settings are made via a DIP switches, which means that programming tools are not required to put the gateway itself into operation.

For programming Pluto there are ready-made function blocks which, via a Pluto gateway, send and receive data from the supervisory system.

### Data from Pluto

Via CANopen a supervisory PLC system can have access to the I/O and other variables in a Pluto safety PLC. Global I/Os in a Pluto safety PLC are accessible via CANopen PDO messages. Local data in Pluto units can be read via CANopen SDO messages together with the PLC codes in the supervisory system.

### Data to Pluto

Via CANopen a supervisory PLC system can send non-safety-related information to a Pluto safety PLC. A total of 64 Boolean values and 8 different 16-bit registers can be transmitted (CANopen PDO or SDO messages). Function blocks for these commands are available in Pluto Manager.

### Pluto bridge

A GATE-C2 can also be used to advantage as a CAN bridge when it is required to divide a Pluto safety bus into several sections. This is particularly useful when long databus cables are needed.

There is also a built-in filter function which makes it possible to block any data that is not required for use on the other side of the bridge, which reduces the databus loading in the other sections and thereby permits longer databus cables.



## Technical data - GATE-C2

<b>Manufacturer</b>	ABB AB/Jokab Safety, Sweden
<b>Article number/ordering data:</b>	2TLA020071R8100 GATE-C2
<b>Databuses:</b>	-Pluto safety bus CAN (isolated) -CANopen CAN (isolated)
<b>Pluto safety bus speeds:</b>	100, 200, 250, 400, 500, 800 and 1000 kbit/s (automatic speed detection)
<b>CANopen speeds:</b>	125, 250 and 500 kbit/s (set via DIP switch) 10, 20, 50, 100, 125, 250, 500, 800 and 1000 kbit/s (via software)
<b>CANopen address:</b>	Setting via DIP switches or software (1-63)
<b>CANopen version:</b>	"Version 4.02 of the CiA Draft Standard 301"
<b>Connections:</b>	Top, 3-pole terminal for Pluto safety bus (included) Front, 5-pole terminal for CANopen (included) Bottom, 2-pole terminal for 24 V DC (included)
<b>Status indications:</b>	Pluto safety bus status indication via LED CANopen status indication via LED
<b>Operating voltage:</b>	24 V DC, -15% till +20%
<b>Current at 24 V:</b>	< 100 mA (recommended fuse ≤6 A)

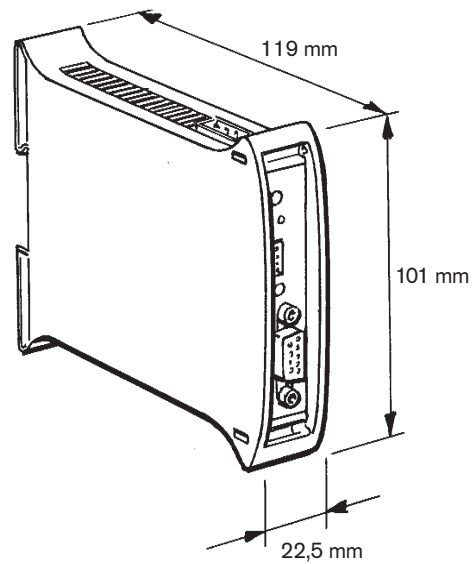

<b>Dimensions (w x h x d):</b>	22.5 x 101 x 119 mm
<b>Installation:</b>	35 mm DIN rail
<b>Operating temperature (ambient):</b>	-10°C to + 55°C
<b>Temperature, transport and storage:</b>	-25°C to + 55°C
<b>Humidity:</b>	EN 60 204-1 50% at 40°C (ambient 90% at 20°C)
<b>Enclosure classification:</b>	Enclosure IP 20 - IEC 60 529 Terminals IP 20 - IEC 60 529

## Gateway block schematic diagram - Pluto CANopen

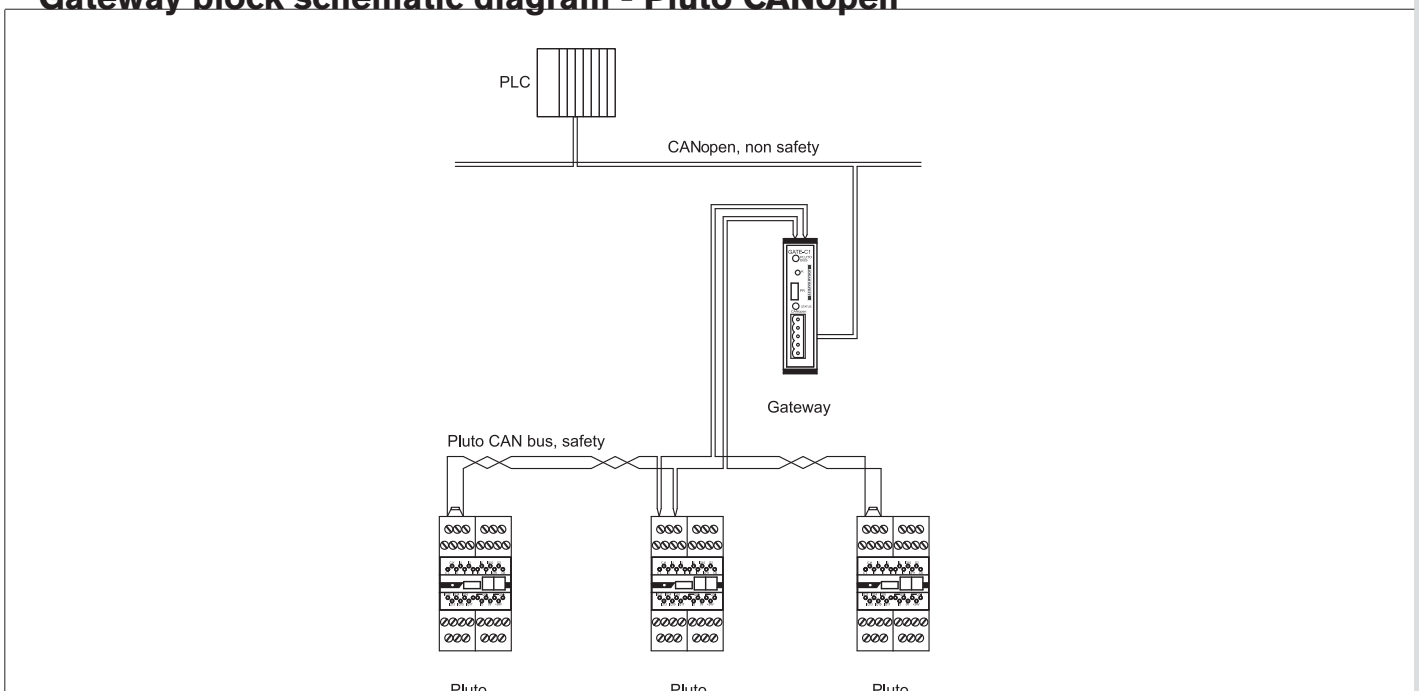

## Pluto gateway

# GATE-E2

### Use:

Bi-directional status information from the Pluto safety PLC

Profinet, Ethernet/IP, Modbus TCP

### Features:

Two-way communication

Built-in filter function, shared network

Can be located anywhere in the databus

Common interface with Pluto

Ready-made function blocks

Profibus DP

DeviceNet

CANopen

Profinet  
Ethernet/IP  
Modbus TCP



Pluto gateway is a unit providing two-way communication between a Pluto safety PLC and other field buses.

The Pluto gateway is a compact unit mounted on a DIN rail, and can be connected anywhere in a Pluto safety bus. The unit has a common interface with Pluto, i.e. the same cabling, and the Pluto Manager PC program can be used for servicing and where necessary programming. Normally, however, all the settings are made via a DIP switches, which means that programming tools are not required to put the gateway itself into operation.

For programming Pluto there are ready-made function blocks which, via a Pluto gateway, send and receive data from the supervisory system.

### Protocol

PLUTO Gateway GATE-E2 handles the status from and to Pluto safety PLCs via Ethernet protocols EtherNet/IP, PROFINET, Modbus TCP and a simple binary protocol that uses TCP/IP.

For IP-address configuration, etc. there is a simple web server and a terminal server.

### Data from Pluto

Via one of the Ethernet protocols a supervisory PLC system can have access to the I/O and other variables in a Pluto safety PLC. Global I/Os in a Pluto safety PLC are accessible via the usual I/O transfer in the respective protocol. Local data in Pluto units can be read by special commands together with the PLC codes in the supervisory system.

### Data to Pluto

Via the Ethernet protocol a supervisory PLC system can transmit non-safety-related information to a Pluto safety PLC. A total of 64 Boolean values and 8 different 16-bit registers can be transmitted. Function blocks for these functions are available in Pluto Manager.



Technical data - GATE-E2	
<b>Manufacturer</b>	ABB AB/Jokab Safety, Sweden
<b>Article number/ ordering data:</b>	2TLA020071R8300 GATE-E2
<b>Buses:</b>	Pluto-bus CAN (isolated) Profinet (isolated) Ethernet/IP (isolated) Modbus TCP (isolated)
<b>Pluto safety bus speeds</b>	100, 200, 250, 400, 500, 800 and 1000 kbit/s (automatic speed detection)
<b>Ethernet</b>	10/100 Mbit/s Half and full duplex
<b>Ethernet protocol</b>	Status from and to Pluto safety PLC - EtherNet/IP - PROFINET (in development) - Modbus TCP - Binary server (TCP/IP)  Note that certain combinations of server protocols cannot be used simultaneously.  Gateway status and IP address configuration - Web server - Terminal server (TCP/IP)
<b>EtherNet/IP</b>	According to ODVA "CIP Edition 3.2" and "EtherNet/IP Adaption of CIP Edition 1.3". Minimum RPI of 50 ms
<b>PROFINET</b>	PROFINET
<b>Modbus TCP</b>	According to the Modbus organisation, version 1.0b (approx. 20 messages per second).
<b>Binary server (TCP/IP)</b>	Simple TCP/IP protocol to send status from/to the Pluto system.

<b>Web server</b>	For simple sharing of IP addresses.
<b>Terminal server (TCP/IP)</b>	Simple server with the same commands as via the serial programming port in the unit.
<b>IP address</b>	Static sharing via web server or via programming port.
<b>Gateway configuration</b>	Takes place via EtherNet/IP, PROFINET, Modbus TCP or via the binary TCP/IP server.
<b>Connections</b>	Top, 3-pole terminal for Pluto safety bus (included) Front, Ethernet connection via RJ-45 (screened cable cat. 5e FTP) Bottom, 2-pole terminal for 24 V DC (included)
<b>Status indications</b>	Pluto safety bus status indication via LED (Pluto safety bus) Ethernet module status indication via LED (Mod Status) Ethernet network status indication via LED (Net Status)
<b>Operating voltage</b>	24 V DC, -15 % till +20 %
<b>Current at 24 V</b>	< 150 mA (recommended fuse ≤ 6 A)
<b>Dimensions (w x h x d):</b>	35 x 101 x 120 mm
<b>Installation</b>	35 mm DIN rail
<b>Operating temperature (ambient)</b>	-10°C to + 55°C
<b>Temperature, transport and storage</b>	-25°C to + 55°C
<b>Humidity</b>	EN 60 204-1 50 % at 40°C (ambient 90 % at 20°C)
<b>Enclosure classification</b>	Enclosure IP 20 - IEC 60 529 Terminals IP 20 - IEC 60 529

## Gateway block schematic diagram - Pluto Ethernet

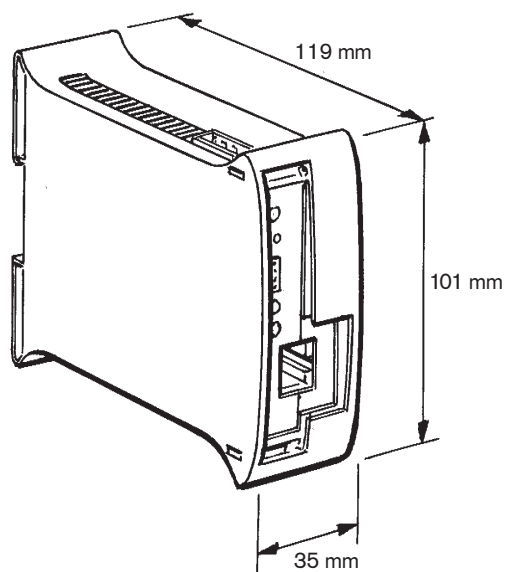
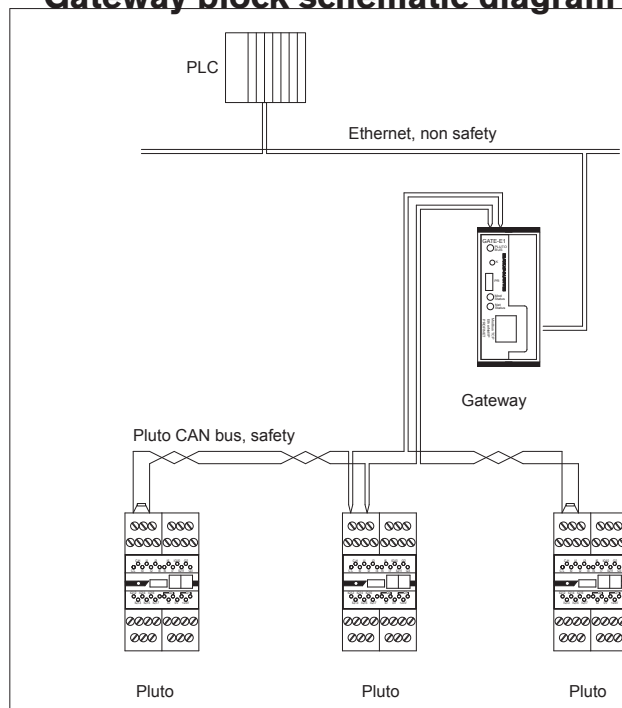



Pluto

# Safe Encoder

## Use:

Safe position and speed determination of machine movements.

## Features:

- High resolution
- Selectable resolution
- Connected directly to the Pluto safety bus
- Ready-made function blocks



### Rotational absolute value sensor for safe positioning

Together with a Pluto safety PLC, this rotational absolute encoder can be used for safe position determination. This is particularly useful in the case of such equipment as gantry robots, industrial robots, etc. Also in eccentric shaft presses, existing cam mechanisms can be replaced by absolute value position sensors for safe positioning. The sensors are available in single and multi-turn versions.

Up to 16 absolute encoders can be connected to a Pluto CAN databus. A Pluto on the databus reads the sensor values, which are evaluated. With a special function block in the PLC code, it is possible to design two-channel solutions with the sensors. The user can obtain safe values for position and speed from these values. This enables supervision of stationary and overspeed conditions.

The absolute value sensors are standard sensors with modified software to meet the safety requirements.

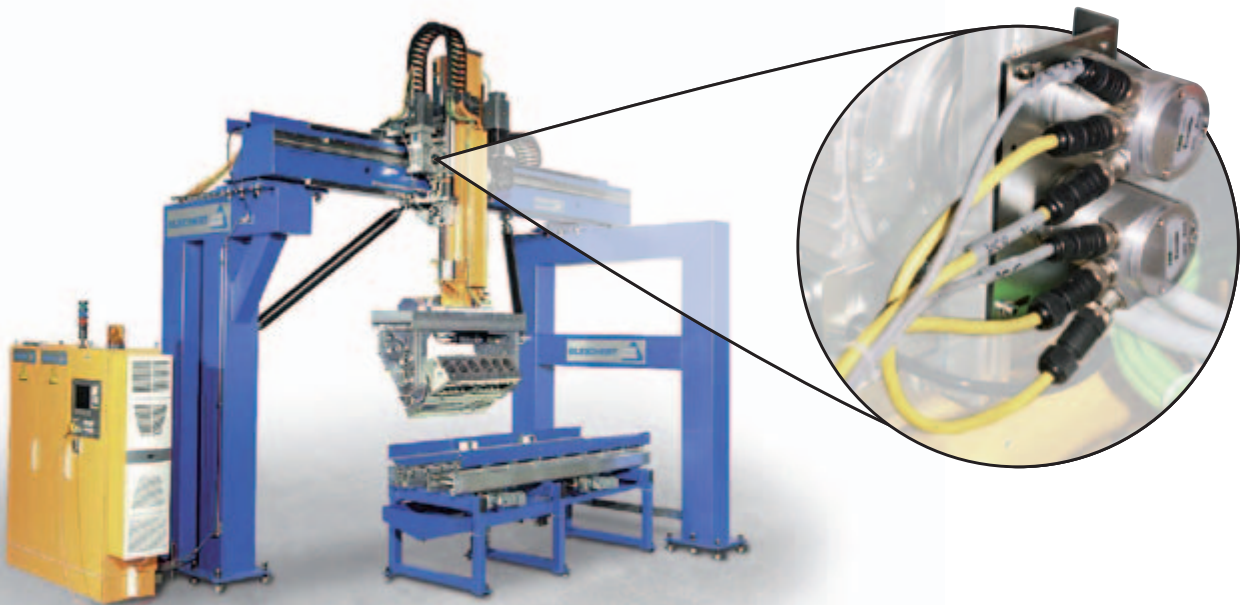

*Example of an application where 2 sensors provide safe position determination in a gantry robot.*

## Technical data – Safe Encoder RSA 597

<b>Manufacturer</b>	ABB AB/Jokab Safety, Sweden
<b>Article number/ordering data:</b>	2TLA020070R3600 RSA 597
<b>Ambient temperature</b>	-40°C .. +70°C
<b>Temperature, transport and storage</b>	-30°C .. +70°C
<b>Ingress protection class</b>	IP-67 in accordance with IEC 60529
<b>At shaft inlet</b>	IP-66 in accordance with IEC 60529
<b>Vibration (55 to 2000 Hz)</b>	< 300 m/s <sup>2</sup> in accordance with IEC 60068-2-6
<b>Shock (6ms)</b>	< 2,000 m/s <sup>2</sup> in accordance with IEC 60068-2-27
<b>Material, enclosure</b>	Aluminium
<b>Surface treatment</b>	Painted and chromed or anodised
<b>Weight</b>	Approx. 300 g
<b>Accuracy and resolution</b>	
<b>Resolution</b>	13 bits, 8192 positions per rotation
<b>Accuracy</b>	± ½ LSB (Least Significant Bit)
<b>Operating voltage</b>	9-36 V dc
<b>Polarity-protected</b>	Yes
<b>Short-circuit protected</b>	Yes
<b>Databus speed</b>	5 kbit/s - 1 Mbit/s, preset at 500kbit/s
<b>Address input</b>	Active low
<b>Code type</b>	Binary
<b>Programmable functions</b>	Resolution, 0 position Direction, Databus speed
<b>Current consumption</b>	50 mA at 24V dc
<b>Max current consumption</b>	100 mA



Safe Encoder RSA 597 – single turn

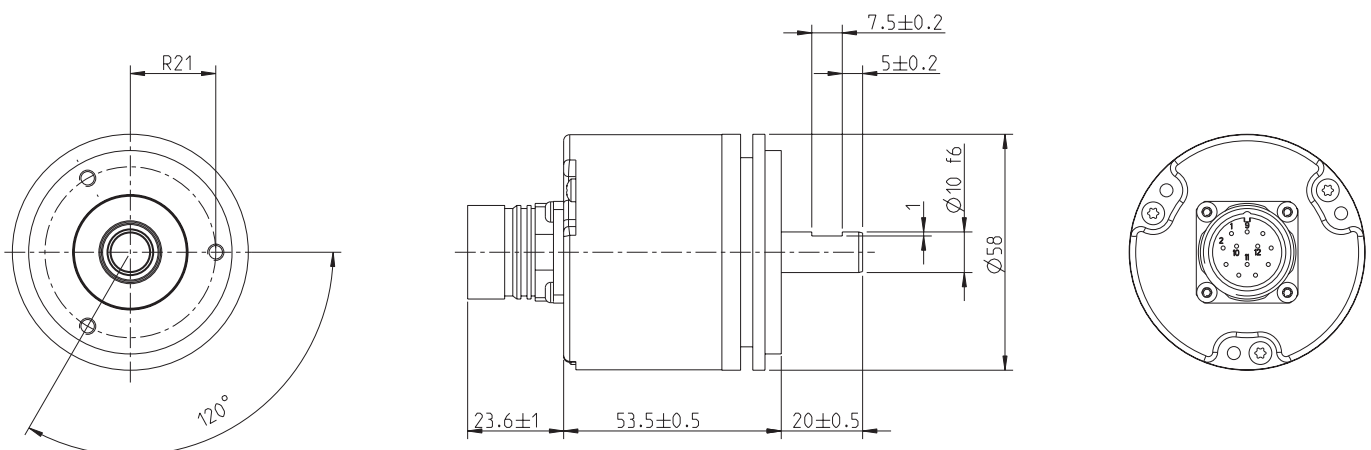

Technical data – Safe Encoder RSA 698	
<b>Manufacturer</b>	ABB AB/Jokab Safety, Sweden
<b>Article number/ordering data:</b>	2TLA020070R3700 RSA 698
<b>Ambient temperature</b>	-40°C .. +70°C
<b>Temperature, transport and storage</b>	-30°C .. +70°C
<b>Ingress protection class</b>	IP-67 in accordance with IEC 60529
<b>At shaft inlet</b>	IP-66 in accordance with IEC 60529
<b>Vibration (55 to 2000 Hz)</b>	< 100 m/s <sup>2</sup> in accordance with IEC 60068-2-6
<b>Shock (6ms)</b>	< 2,000 m/s <sup>2</sup> in accordance with IEC 60068-2-27
<b>Material, enclosure</b>	Aluminium
<b>Surface treatment</b>	Anodised
<b>Weight</b>	Approx. 400g
<b>Accuracy and resolution</b>	
<b>Resolution, total</b>	25 bit 13 bits, 8192 positions per rotation 12 bits, 4096 rotations
<b>Accuracy</b>	± 1 LSB (Least Significant Bit)
<b>Operating voltage</b>	9-36 V dc
<b>Polarity-protected</b>	Yes
<b>Short-circuit protected</b>	Yes
<b>Databus speed</b>	10 kbit/s - 1 Mbit/s
<b>Code type</b>	Binary
<b>Programmable functions</b>	Resolution, 0 position
<b>Current consumption</b>	50 mA at 24V dc
<b>Max current consumption</b>	100 mA



Safe Encoder RSA 698 – multi turn

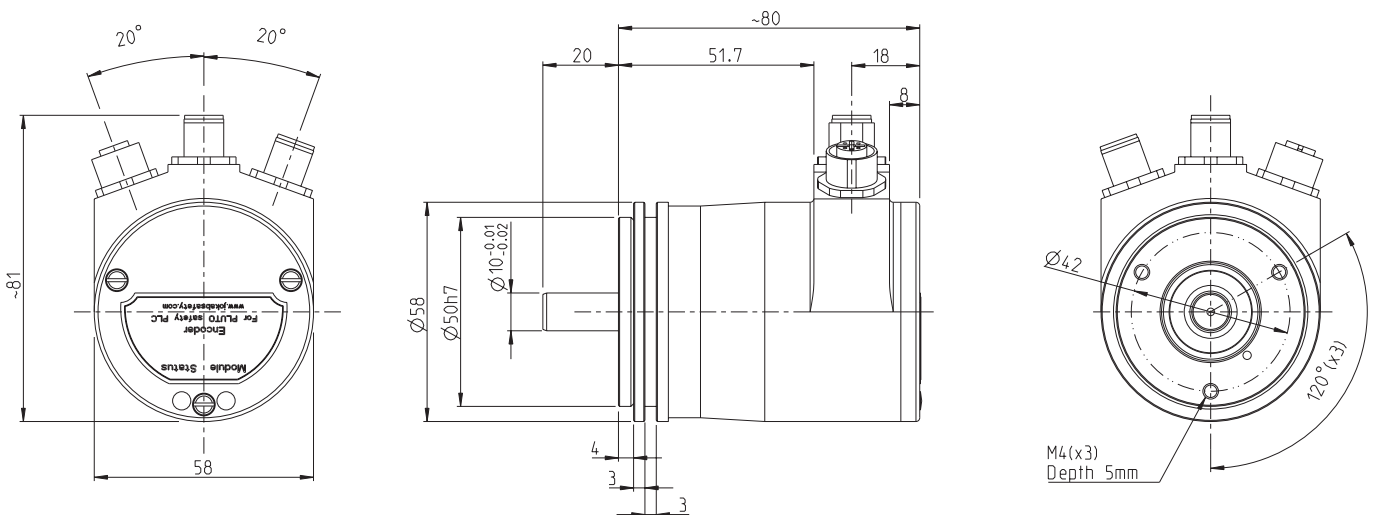

## Safe Encoder

Function block for a single-turn encoder that generates safe position and speed values from two absolute encoders.

### Function

The block reads and evaluates one absolute encoders. The position value is sent to the 'Position' output. The 'Speed' output is the average value for the speed, at the rate of pulses/10 ms. If an error occurs, the 'OK' output is set to zero. In certain applications the values of 'Position' and 'Speed' are used in conjunction with the 'OK' output.

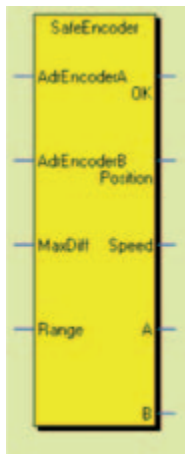

### Descriptions of inputs and outputs

- AdrEncoderA: Encoder A node address
- AdrEncoderB: Encoder B node address
- MaxDiff: Max allowed deviation between the encoders (max 2% of Range)
- Range: Number of increments per revolution
- OK: Set when encoders are working OK and the position values are within the margin set by 'MaxDiff'
- Position: Position value
- Speed: Speed value as increments/10ms
- A: Encoder A position. Must not be used in PLC program!
- B: Encoder B position. Must not be used in PLC program!

**NOTE!** Position values from single encoders are only available for adjustment purposes and must NOT be used for safety.

**NOTE!** When error occurs 'Position' = -1, 'Speed' = -32768 and the OK output will be reset.

## Safe Encoder Multiturn

Function block for a multi-turn encoder that generates safe position and speed values from two absolute encoders. Operative system 2.4.4 or higher is required.

### Function

The block reads and evaluates two absolute encoders. The average value for the two sensors is calculated and sent to the 'Position' output. The 'Speed' output is the average value for the speed, at the rate of pulses/10 ms. The block monitors that the encoder position values do not differ by more than the input value set by 'MaxDiff'. If an error occurs, the 'OK' output is set to zero. In certain applications the values of 'Position' and 'Speed' are used in conjunction with the 'OK' output.



### Descriptions of inputs and outputs

- AdrEncoderA: Encoder A node address
- AdrEncoderB: Encoder B node address
- MaxDiff: Max allowed deviation between the encoders (max 2% of IncrPerRev)
- IncrPerRev: Number of increments per revolution
- OK: Set when encoders are working OK and the position values are within the margin set by 'MaxDiff'
- Position: Position value
- Speed: Speed value as increments/10ms
- A: Encoder A position. Must not be used in PLC program!
- B: Encoder B position. Must not be used in PLC program!

**NOTE!** Position values from single encoders are only available for adjustment purposes and must NOT be used for safety.

**NOTE!** When error occurs 'Position' = -1, 'Speed' = -32768 and the OK output will be reset.

## Encoder Cam

Function block for electronic cam gear.

### Function

Output Q is activated if the value of the input register 'PosReg' is within the limits for 'MinPos' and 'MaxPos'.

**NOTE!** It is possible to specify a value that defines the sensor's zero position. Position < 0 is not permitted.

Example: If MinPos = 3000 and MaxPos = 200, Q is activated when the position is greater than 2999 or less than 201.

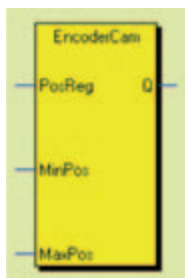

### Descriptions of inputs and outputs

- PosReg: Input for the position value
- MinPos: Minimum limit value
- MaxPos: Maximum limit value

# AS-i Safety

## Two-wire bus system

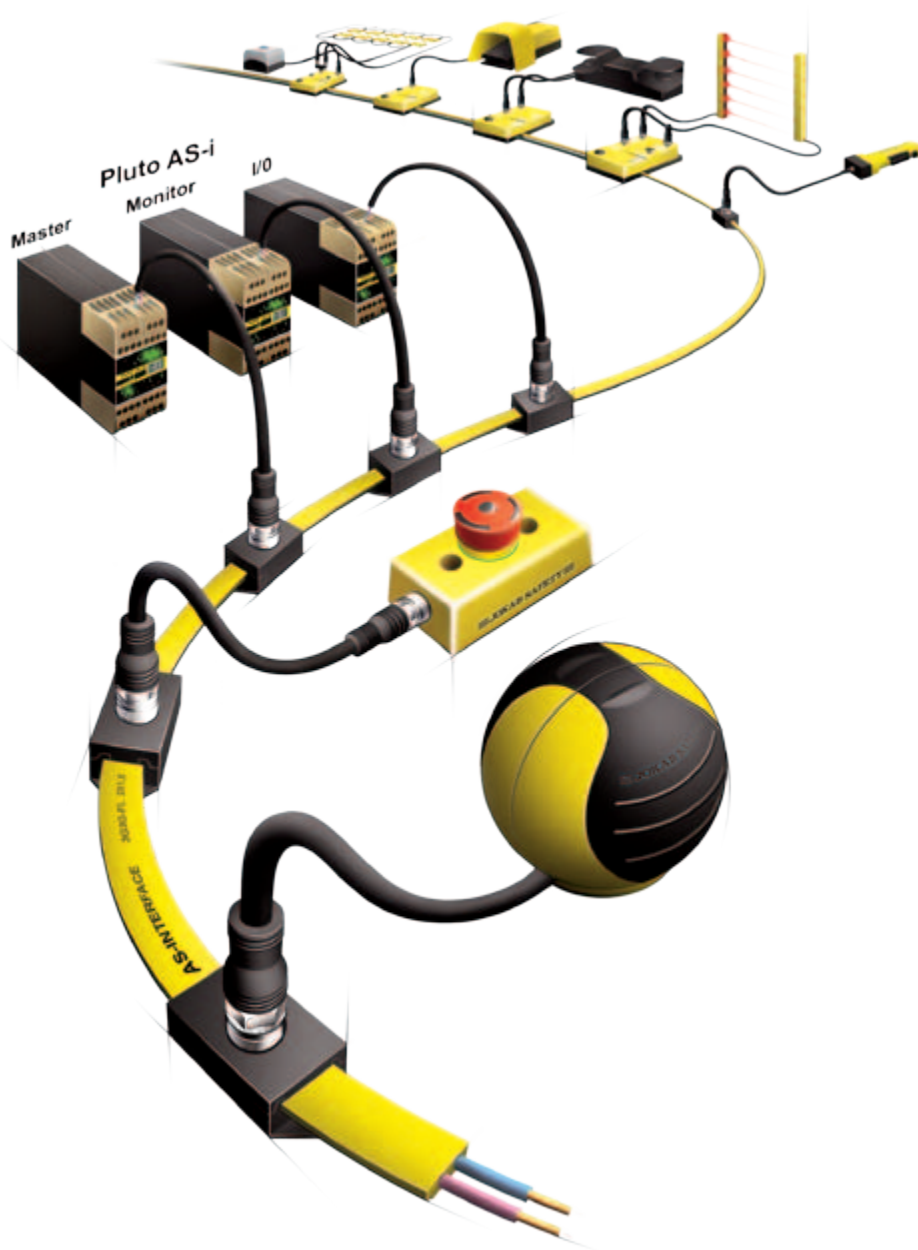



<b>Contents</b>	<b>Page</b>
<i>Why should I use the bus system at component level?</i> _____	<b>3:2</b>
<i>AS-i Safety from ABB Jokab Safety</i> _____	<b>3:4</b>
<i>Pluto AS-i</i> _____	<b>3:6</b>
<i>Why should you use safety node Urax?</i> _____	<b>3:11</b>
<i>Safety node Urax-A1/A1R</i> _____	<b>3:12</b>
<i>Safety node Urax-B1R</i> _____	<b>3:14</b>
<i>Safety node Urax-C1/C1R</i> _____	<b>3:16</b>
<i>Safety node Urax-D1R</i> _____	<b>3:18</b>
<i>Safety node Urax-E1</i> _____	<b>3:20</b>
<i>Non-safe node Flex</i> _____	<b>3:22</b>

Descriptions and examples in this book show how the products work and can be used. This does not mean that they can meet the requirements for all types of machines and processes. The purchaser/user is responsible for ensuring that the product is installed and used in accordance with the applicable regulations and standards. We reserve the right to make changes in products and product sheets without previous notice. For the latest updates, refer to [www.abb.com/lowvoltage](http://www.abb.com/lowvoltage). 2011.

# Why should I use the bus system at component level?

## -provides simplicity in the construction of systems

The AS-i system provides benefits both when the system is planned and installed. A single network can, for example, be divided into monitoring and control of different work zones. The zones can be dependent on each other or not, even though they are controlled and are connected to the same general process.

## -to save installation time

Components designed for the AS-i bus system can easily connect to the network wherever this is required. The required function is then selected in the control system.

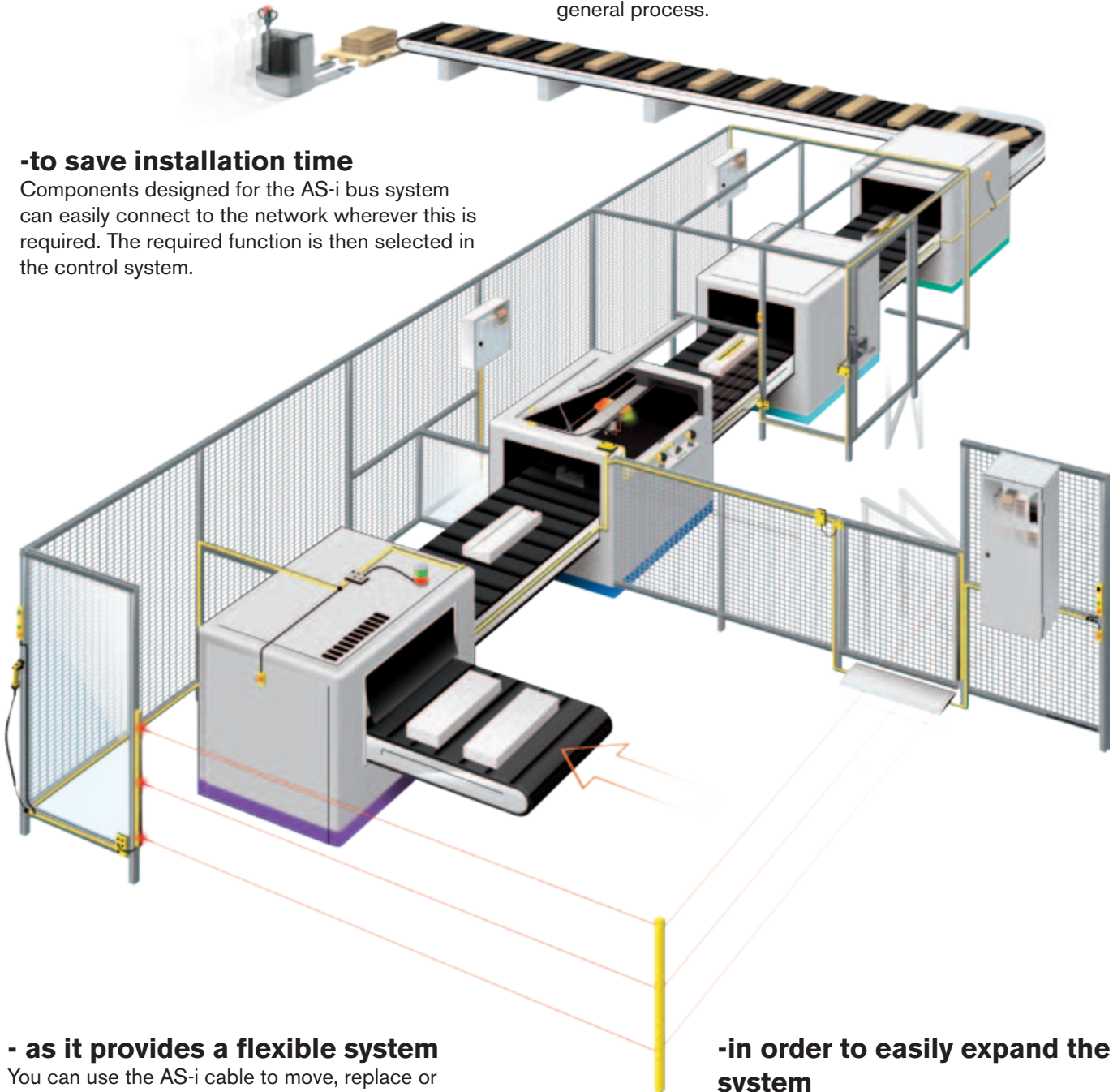

## - as it provides a flexible system

You can use the AS-i cable to move, replace or add new safety products anywhere as needed. Additional monitors such as Pluto AS-i can also be connected in the same way.

## -in order to easily expand the system

The system's construction allows, where necessary, the easy extension or expansion of the network. Cable is added which thereby extends the production line without any additional controllers being installed.

### How does the bus system AS-Interface work?

The AS-i system is distinguished by its special yellow profile cable. The cable connects all sensors, transducers and actuators on the network to a master system. The component parts of a system can include both non-safe and safe products. This means that both operational and safety related products can be mixed in a network. The bus system drives a Master-Slave (node) configuration where each I/O module corresponds to a common master.

Communication takes place through the yellow cable which also provides the nodes with supply voltage. The installation of the cable is usually done along a production line or centrally around the AS-i system's I/O products. After commissioning the system can always be expanded by adding branches or extensions to the cable. In a similar way, more products can be added, moved or replaced. The changes are easily made in the software to the controller. With the AS-i concept, decentralised systems can be designed with all products, non-safe and safe monitored by a device. This advantage means that the system can be handled as zones where one zone can be down, another can be in operation and a third manually operated. Without degrading operation and safety or influencing each other's zones.

### Why is the AS-i Safety so good from a safety perspective?

The simple connection to a cable also applies to safety components. The risk of incorrect wiring is thereby minimised. Each safety node, i.e. safety product, has its own address on the AS-i bus along with a unique safety code.

The additional requirement for an AS-i system to cope with safety products is that there must be extra safe monitoring. The control ("Master") does not need to be safe, but is complemented with a safety Monitor (however, safety PLC Pluto AS-i can act as both Master and/or Monitor).

The advantage of safety within AS-i is that it is easy to introduce changes without significant costs compared to traditional safety systems that require new cable running from the electrical cabinet for each new protection. Moreover, experience shows that most safety systems need to be retrofitted to adapt the protection to suit the changes to production.

### Voltage and communications

The AS-i network is maintained by a special AS-i power supply unit that generates a regulated DC output voltage between 29.5 and 31.6 V. This supplies voltage to the network nodes at the same time as communications are transmitted in a superimposed manner.

### Nodes

Safety nodes (maximum 31) and A / B-nodes (maximum 62) are connected to the AS-i for both inputs and outputs.



### Two-wire cable

The AS-i cable is a two-wire cable (2x1.5mm<sup>2</sup>) that is not shielded. Connection is made using piercing technology, where the cable housing is self-restoring if a connection is moved. The cable retains enclosure protection class IP67 in this way.

### Adaptation devices

For the AS-i cable it is possible to connect the adaptation devices that act as a link between a component and the AS-i system. These adaptation devices are available as both safety nodes and nodes for non-safe products.

### Sensors with integrated safety nodes

Some AS-i adapted components have nodes directly built into the product, for example, there is one safety node in the customised Smile Emergency Stop.

*The AS-interface makes it easy to connect and remove products to and from the AS-i bus.*

# AS-i Safety from ABB Jokab Safety

## Safety level

Pluto, Urax and our other products with integrated safety nodes achieve up to safety level cat. 4/PL e in compliance with EN ISO 13849-1.

## Pluto AS-i

Pluto is designed to control (Master) the AS-i bus and/or monitor (Monitor) it. Pluto can also serve as a safe I/O module for the bus.

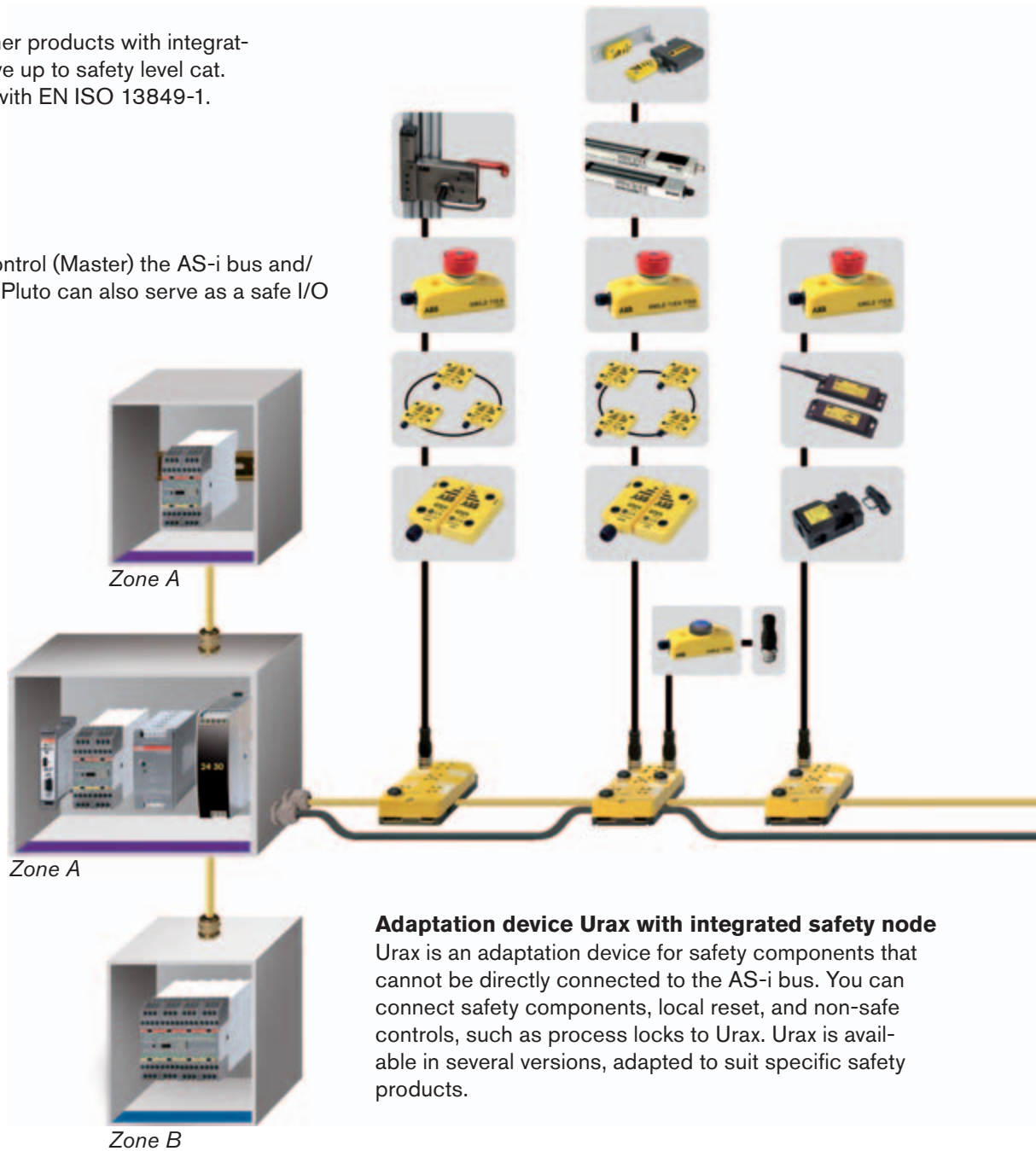

## Adaptation device Urax with integrated safety node

Urax is an adaptation device for safety components that cannot be directly connected to the AS-i bus. You can connect safety components, local reset, and non-safe controls, such as process locks to Urax. Urax is available in several versions, adapted to suit specific safety products.

## The AS-i system

The AS-i cable can be connected to the safety products separately or through the adaptation device Urax. Some components have an integrated AS-i node and are connected via an M12 connection directly to the yellow AS-i cable. Traditional products without an integrated AS-i node need to be connected via the safety node Urax. In both cases, the highest level of safety is maintained.

The AS-i cable is powered by 30V DC power supply and connected to a special AS-i power supply unit. Some components have power requirements that are higher than the AS-i cable is able to supply. Therefore, there is also a black cable (AUX 24V DC) with secondary supply voltage that is able to supply more current.

## Possible connections for a complete system:

- all our sensors for AS-i via Urax
- all Pluto PLCs, gateways and absolute sensors through Pluto's safety bus to the Pluto AS-i
- operator panel via the programming port on Pluto
- expansion relay for multiple outputs



### Easy connections to the AS-i cable

Adaptation devices are clamped directly to the AS-i cable. Transition from the AS-i cable to M12 units is made via a T connector. Cable branches or extensions of the AS-i cable are made using a splitter box.

### Sensors with integrated AS-i safety nodes

Some of our products can be ordered with integrated AS-i node. These are connected to the yellow cable with a M12 contact directly to the yellow AS-i cable via a screw terminal which is clamped to the cable. More information can be found under each product.

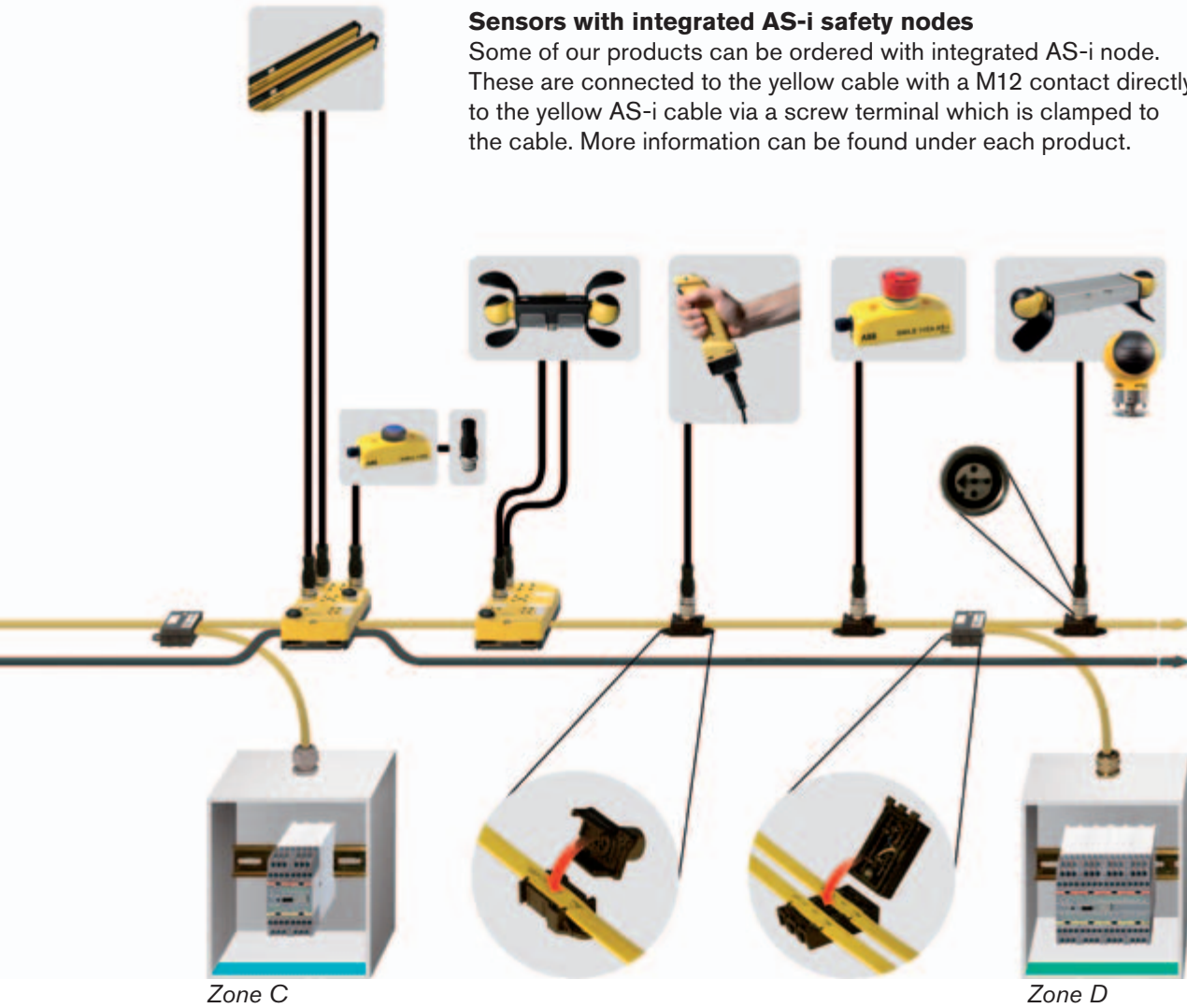

### AS-interface

#### - an intelligent cable running system

The field bus system AS-interface came to light in the 90s. The system was the result of a collaboration between several component manufacturers for machine control. The idea was a bus system at a component level where the goal was simplicity and flexibility. Since the system was launched, many new and innovative ideas have been added.

### AS-International Association

In 1991, the AS-International Association for organisational cohesion and marketing was founded. The AS-i association works in both an advisory and auditing capacity to ensure the AS-i standard is maintained.

The goal of the AS-i Association is that the AS-interface is to become a world standard for easy communication for components within the automation industry.

The distinguishing feature of the AS-interface is that data communication is mixed with the power supply. This is done in a simple two-wire cable. In 2001 safety was integrated in the AS-interface via the work group Safety at Work, which also includes ABB Jokab Safety.



# Pluto AS-i

## Approvals:



## Control of:

- Safety products in dynamic and static circuits as well as in AS-i networks
- Electrically controlled actuators such as contactors, valves, motors
- Indicators and buttons

## Features:

- AS-i interface where up to 31 safety products can be connected
- Dispersed constructions of machines
- Great flexibility
- Up to 10 sensors in series connected to one input
- Software Pluto Manager free of charge
- Handles conventional circuit breakers as well as dynamical sensors
- Custom made safety bus
- Very large systems can be monitored by Pluto AS-i



### A safety PLC for AS-i Safety

Pluto AS-i is a safety PLC designed for the AS-i Safety concept where all the safety components are connected to a single cable. Pluto AS-i has the same characteristics as a standard Pluto and works in the same way with the only difference being the AS-i bus. As with a standard Pluto, Pluto AS-i is in an All-Master system with its own safety bus and is designed for dynamic and static safety circuits where inputs and other information are shared across the bus. Pluto AS-i also has a reduced number of failsafe inputs (I), failsafe relay and transistor outputs (Q) and terminals that are user-defined and serve as failsafe inputs or non-failsafe outputs (IQ).

For the AS-i bus, Pluto AS-i acts as a master, monitor, or I/O controller. As a master it controls and distributes all communication while it works as a monitor. In monitor mode, it listens to the bus and controls its safe outputs. As an I/O controller it serves as a slave node on the AS-i bus and communicates with another master or monitor.

### Pluto AS-i is available in two models

ABB Jokab Safety's Pluto AS-i is available in two different models. A smaller version, Pluto AS-i, and a larger model with a larger number of I/Os, Pluto B42 AS-i. Both models have a model-dependent number of I/Os. If more I/Os are necessary, you can connect Pluto AS-i to Pluto B16, B20 or B46 via the Pluto safety bus.

### Pluto AS-i is programmed using Pluto Manager

Programming Pluto AS-i is made easy using TÜV-reviewed software with ladder language and finished blocks for various safety functions. The Pluto Manager software is also free to download from our website.

## Technical information – Pluto AS-i

### I/O properties

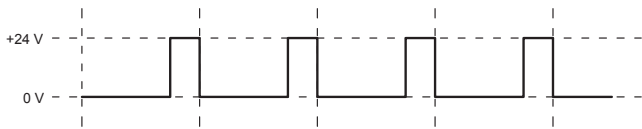

A dynamic signal makes it possible to achieve PL e as specified in 13849-1 with only one conductor. By transmitting a square wave and then evaluating the signal when it comes back to the controller you achieve the redundancy required. The kind of signal Pluto expects at the input terminal is determined in Pluto Manager (A or B pulse and if the signal is to be inverted or not).

Static signals (+24 V or 0 V) can be connected to all inputs on Pluto. The kind of signal Pluto expects at the terminal input is determined in Pluto Manager.

There are safety products with internal monitoring of dual OSSD signals (the device detects its own faults rather than Pluto doing this). From these devices, at least one of the two signals is connected to an I-input in Pluto, i.e. both signals must not be connected to the IQ-terminals.

The IQ-terminals can be used either as individual failsafe inputs or as non-failsafe outputs (e.g. for indicator lamp or status signal). The terminal blocks can also be used as both input and output simultaneously, which is useful for example for push buttons (input) with indicator lamp (output). This function is designed primarily for reset buttons to reduce the number of used inputs on the controller. The terminal block's I/O characteristics are determined in Pluto Manager.

All inputs are individually failsafe as each input is connected separately to both processors in Pluto. In order to maintain the redundancy required for a two-channel structure and PL e in compliance with 13849-1, the dynamic signal must be used. The expected signal to the terminals is also determined in Pluto Manager (static or dynamic signal).

All Q outputs are individually safe and are independently programmable.

The transistor outputs are just like the relay outputs, that is individually safe and independently programmable. However, the transistor outputs are different from the relay outputs as the internal connection provides the nominal input voltage -24 VDC, which is primarily intended for controlling electromechanical components such as contactors and valves.

### Safety bus

The safety bus is a modified CAN-bus and the bus cable can be up to 600 m long at the lowest bus speed. At 400 kb/s the bus can be up to 150 m. Note that the maximum length of the bus depends on whether and how the joints are used. The bus can be both extended and connected to other types of buses through gateways.

### AS-i bus

The AS-i bus is also a safe bus where safety is based on an alternating code table. The bus can be up to 500 m in length provided that the bus master is placed in the middle of the loop. Each AS-i branch should not be longer than 100 m. The loop can be extended by using repeaters. However, there should not be more than two repeaters attached in series due to time constraints.

All safety components that are connected to the AS-i loop take a complete address and are interpreted as slaves. The AS-i bus can handle 31 different addresses where each address can be divided into an A and B slave for non safety I/O. A separate power supply unit with about 30V DC is required for the AS-i bus.

## Pluto Manager and ID-fix

### Pluto manager

The Pluto Manager is freeware for fast, easy and safe programming of the PLC program for Pluto. The programming language used is ladder, which is supplemented with TÜV-approved function blocks for many common features. The software can also be used to configure Pluto's terminal blocks, e.g. the IQ terminals that serve as inputs or outputs are specified and the controller should expect a static or dynamic signal. Pluto Manager can be downloaded from [www.abb.com/lowvoltage](http://www.abb.com/lowvoltage).

### ID-fix

ID-fix is an identification circuit that is unique to each device on the Pluto bus. It includes an identification code and makes it possible to distribute a PLC program in the network and to address Pluto units. There are four different versions: R, R/W, R/W/Data and PROG. In addition to the identification code, R/W/Data may also include safety codes from the AS-i nodes in an AS-i system. PROG includes the current PLC program and is used together with Pluto for program distribution. ID fix is connected between the input terminals ID and 0V.

## Pluto AS-i

### A Pluto AS-i can be used in three ways - as Safety Master, Safety Monitor or as Safety I/O

#### 1. Pluto as Safety Master\*

The master distributes and controls communication on the AS-i bus and acts simultaneously as Safety Monitor.

#### 2. Pluto as Safety Monitor\*

The monitor listens to what is happening on the AS-i bus and controls the safe outputs.

#### 3. Pluto as Safety I/O\*

Multiple safe inputs and/or outputs are controlled and communicate with a safe master or monitor across the AS-i bus.

\*Whether Pluto is used as a Master, Monitor or I/O it can simultaneously control and monitor the safety of a machine.

#### Gateway

Gateways allow you to communicate easily with other bus systems.

Profibus DP  
DeviceNet  
CANopen  
Ethernet

#### Bus connection

Pluto AS-i can be connected with other Pluto units both via the AS-i bus and through the Pluto safety bus.

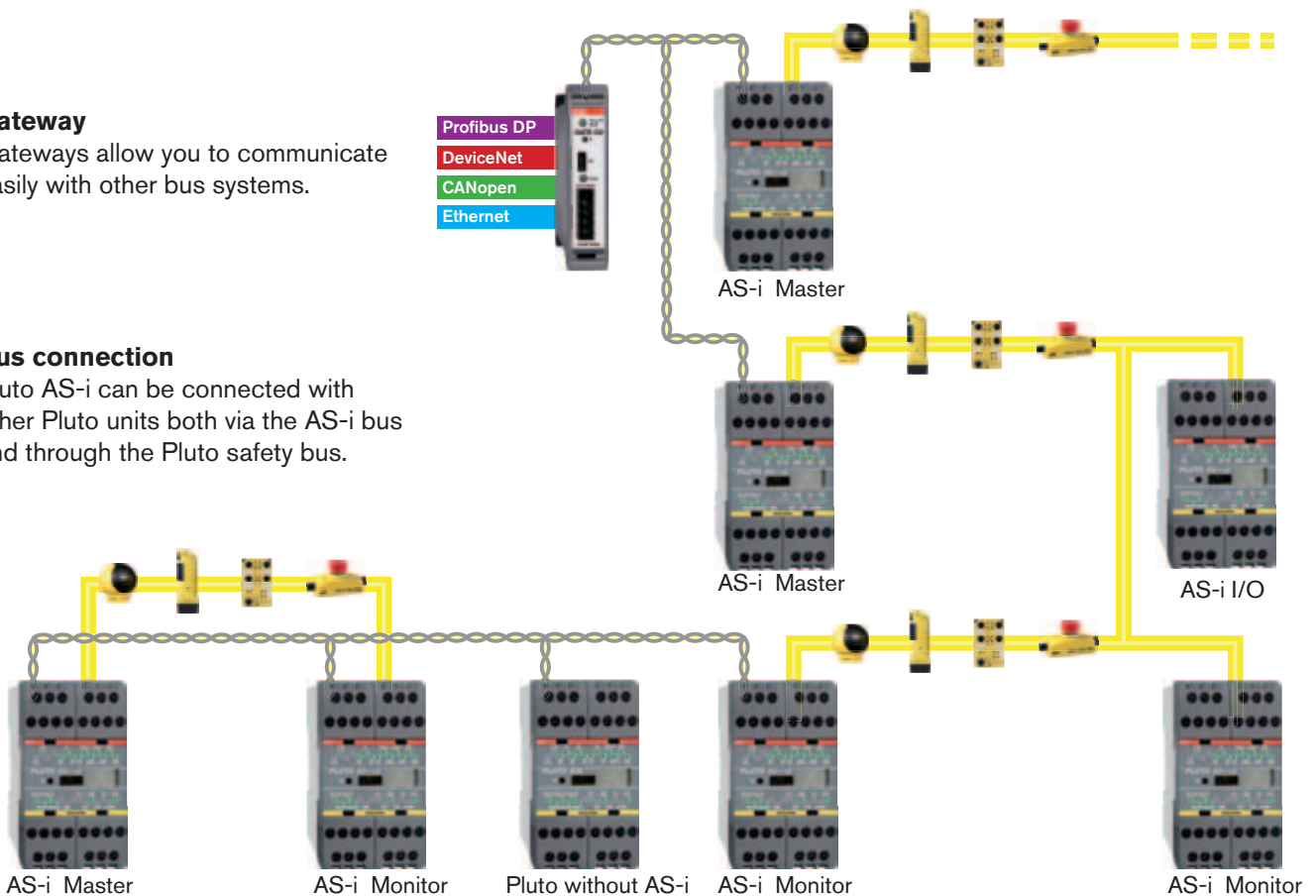

#### How large can you build the system?

From a technical aspect there are no constraints on the size of the system you can build. A Pluto PLC can, in addition to processing a complete AS-i bus, communicate with another Pluto either through a Pluto safety bus or through the AS-i bus.

Through Pluto's safety bus, each Pluto can be a party to the I/Os of others and a total of 32 Plutos can be linked in this way. If two Plutos are connected to each other via the AS-i bus, each Pluto can be connected to 31 other Plutos. Using Gateways the system can be expanded further to other bus systems for information exchange.

Technical data – general	
<b>Manufacturer:</b>	ABB AB/Jokab Safety, Sweden
<b>Colour:</b>	Grey
<b>Operating voltage:</b>	24VDC ±15 %
<b>Assembly:</b>	35 mm DIN busbar
<b>Electrical insulation:</b>	Category II according to IEC 61010-1
<b>Safety level:</b> EN 954-1 EN ISO 13849-1 EN 61508 EN 62061	Cat. 4 PL e/cat. 4 SIL 3 SIL 3
<b>PFH<sub>d</sub></b> Relay output Transistor output	2.00×10 <sup>-9</sup> 1.50×10 <sup>-9</sup>
<b>Failsafe inputs I &amp; IQ</b> Type:  Current at 24V Max surge	+24 V (for PNP sensors), IQ is also configurable as non-safe outputs 5.1 mA 27V continuous
<b>Failsafe transistor outputs Q</b> Output voltage: Tolerance for output voltage: Max current:	-24 VDC Supply voltage - 1.5 V at 800 mA 800 mA
<b>Failsafe relay outputs Q</b> Max voltage Max current	250 VAC 1.5 A
<b>Non-failsafe outputs IQ</b> Type:  Max current/output:	Transistor +24 V, PNP "open collector" is also configurable as failsafe inputs 800 mA
<b>Indicator</b> Input/output LED Display:	1 per I/O (green) 7-segments, two characters

\* Each address can have an A and B node each containing four inputs and four outputs. The number of slaves can thereby be increased to 62.

<b>Pluto-bus</b> Max number of Pluto on the bus: Bus type: Bus speeds:  Bus cable length:	32 CAN 100, 125, 200, 250, 400, 500, 800, 1,000 kb/s Up to 600 m 150 m at 400kb/s
<b>AS-i bus</b> Master profile: Number of slave units: Bus operation mode:  Bus cable length:	M2 31/62* Master Safety monitor Safety monitor, slave and safe I/O module. Up to 500 m 100 m between each repeater
<b>Temperature</b> Ambient temperature: Storage and transport:	-10°C - +50°C -25°C - +55°C
<b>Reaction times</b> Dyn.A or static input to relay output: Dyn.A or static input to transistor output:  Dyn.B or Dyn.C input to relay output: Dyn.B or Dyn.C input to transistor output: Setting "NoFit!":  AS-i bus to relay output: AS-i bus to transistor output:	<20.5 ms + prog. execution time <16.5 ms + prog. execution time  <23 ms + prog. execution time <19 ms + prog. execution time 5 ms shorter reaction time on I & IQ inputs <33 ms + prog. execution time <29 ms + prog. execution time
<b>Additional reaction times</b> Bus between Pluto units Bus between Pluto units following fault	10 ms 10–40 ms
<b>Enclosure protection class</b> Enclosure: Terminal blocks:	IP 40, IEC 60 529 IP 20, IEC 60 529

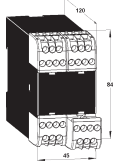
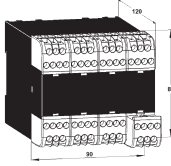
Technical data – type specific		
	<b>Pluto AS-i AS-i bus</b>	<b>Pluto B42 AS-i AS-i bus</b>
Part number/Ordering data:	2TLA020070R1 100	2TLA020070R1400
Failsafe inputs	4 ea (I0..I3)	20 ea (I0..I3, I30..I47)
Failsafe inputs or non-failsafe outputs	4 ea (IQ10..IQ13) Maximum total load 2A	16 ea (IQ10..IQ27) Maximum total load 2A
Analogue inputs	4 ea (IQ10..IQ13) 0..27V	3 ea (I1..I3) 0..27V
Failsafe relay outputs	2 ea (Q0..Q1)	4 ea (Q0..Q1 & Q4..Q5)
Failsafe transistor outputs	2 ea (Q2..Q3)	2 ea (Q2..Q3)
Current monitoring	–	–
Pluto-bus	▪	▪
AS-i bus	▪	▪
Internal current consumption	100 mA	150 mA
Recommended external fuse:	6A	10A
Dimensions (WxHxD)	45 x 84 x 118 mm	90 x 84 x 118 mm

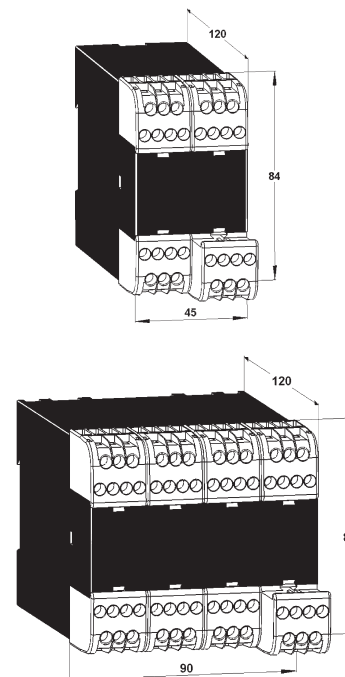

The connection block is removable having to disconnect any cables. The units are assembled with a gap of at least 5 mm.

## I/O – Pluto AS-i

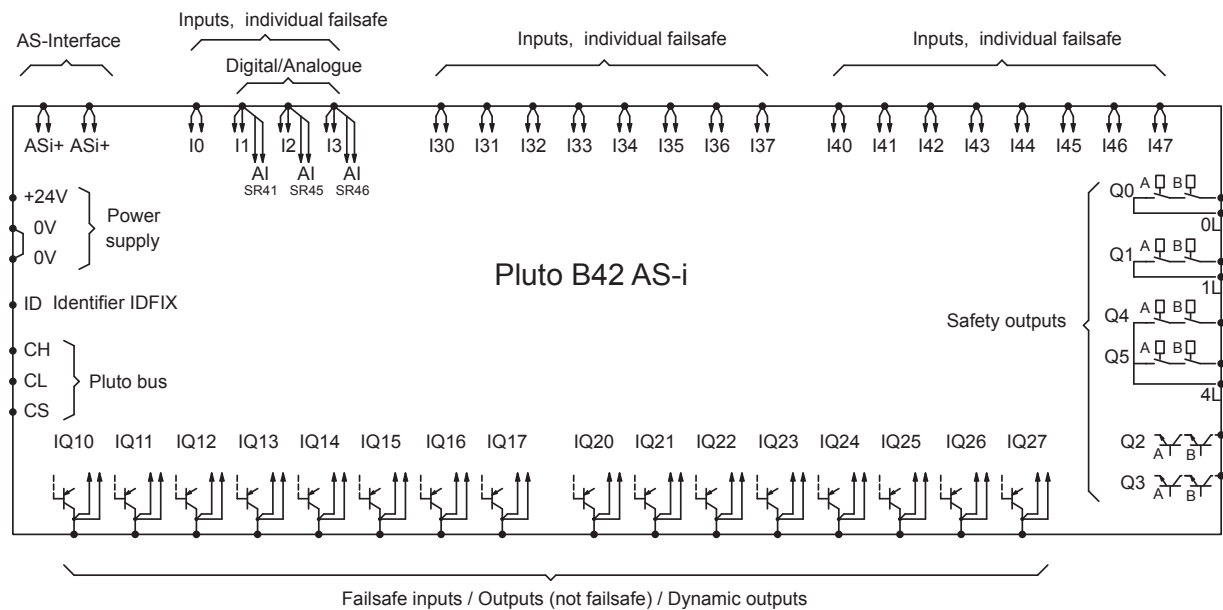
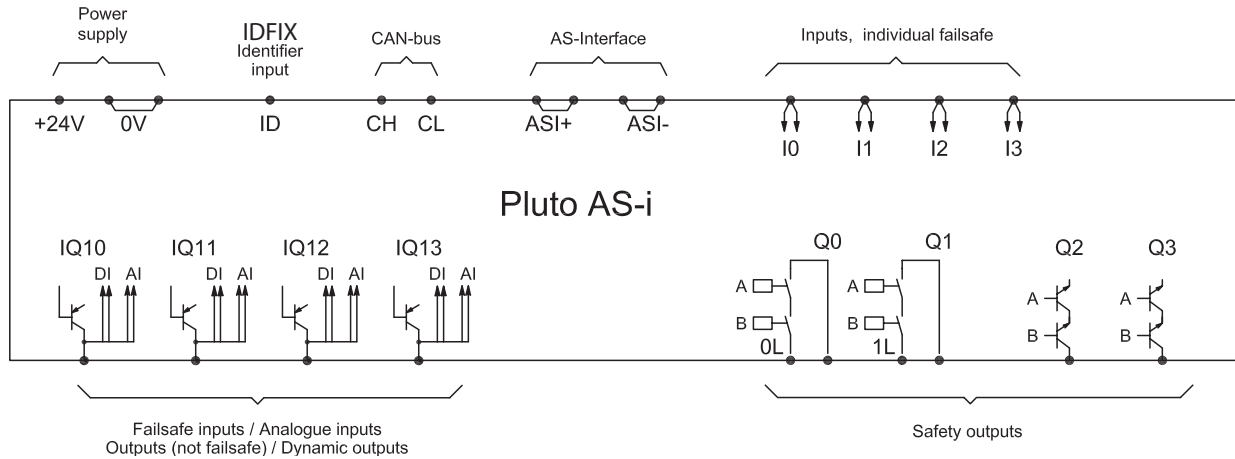

- ID: Connection for identifiers that have a unique ID number that can be read by the system.
- I.. Safety inputs (24 VDC) that are individually safe. This means that you can achieve the highest level of safety with only one input when you use ABB Jokab Safety's dynamic safety components. Otherwise, two inputs per safety function are required.
- IQ.. I/O that can be used as safety inputs or signal outputs, e.g. for indicating or controlling functions that are not safety related. For IQ .. as safety input see I..
- Q0, Q1: Failsafe relay outputs that are individually failsafe and independently programmable.
- Q2, Q3: Failsafe transistor outputs (-24 VDC) that are individually failsafe and independently programmable. Designed for electromechanical components such as contactors and valves.
- Q4, Q5 Failsafe relay outputs with a common potential that are individually failsafe and independently programmable.





# Why should you use safety node Urax?

- to connect safety sensors to AS-i safety.
- to connect non-safe products to AS-i Safety
- to maintain the highest level of safety PL e in compliance with EN ISO 13849-1



**The Urax safety node has safety inputs for sensors and reset buttons, and outputs such as process locks.**

Urax safety node is available in several versions, and is designed for a variety of safety components.

Urax has the capability to connect multiple sensors in series to the highest level of safety PL e in compliance with EN ISO 13849-1.

## Overview Urax

Model	A1	A1R	B1R	C1	C1R	D1R	E1	FLEX
Dynamic sensor (Eden, Tina)	3	3	10					
Two-channel sensors				•	•			
Sensors with OSSD Signals						•		
Two-hand station							•	
Local reset function		•	•		•	•		
External power source			•			•		•
Non-safe outputs	1	1	3			3	3	4

1  
2  
3  
4  
5  
6  
7  
8  
9  
10  
11  
12  
13  
14



## Safety node

# Urax-A1/A1R

### Approvals:

TÜV Nord  

### Application:

Adapts dynamic sensors to the AS-i bus

### Features:

Enables dynamic sensors on the AS-i bus

Multiple sensors in series with maintained safety level

Possibility of local reset

Outputs of non-safe control, e.g. process locks



### Adaptation device for dynamic sensors for AS-i.

Urax-A1/A1R is a safety node for the AS-i bus, where it is possible to connect up to three dynamic sensors, such as Eden, in series in compliance with PL e EN ISO 13849-1.

Switches adapted to dynamic sensors such as Smile Tina can also be connected to the safety circuit.

Urax-A1/A1R also has an output for non-safe control, where it is possible to control non-safety critical equipment such as process locks. Urax-A1R has an additional feature that provides local reset button (R) with LED indicator.

The dynamic safety sensors are controlled by Urax over one hundred times per second which gives a high level of safety.

Urax-A1/A1R has LED indication for the dynamic loop and can be addressed on the bus via the ADDR contact.

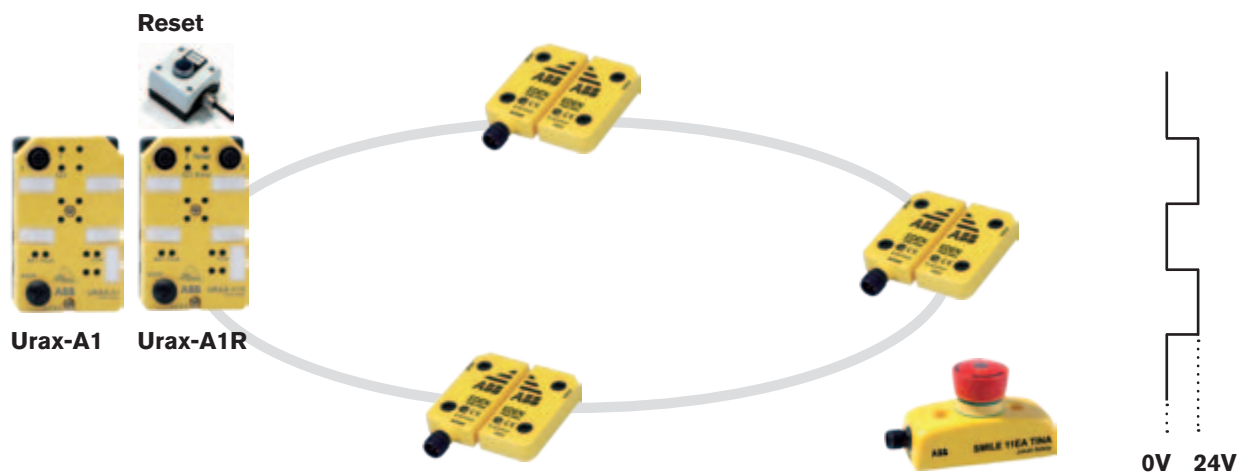

## Technical data – Urax-A1/A1R

<b>Manufacturer:</b>	ABB AB/Jokab Safety, Sweden
<b>Part number/Ordering data:</b>	Urax-A1 2TLA020072R0000 Urax-A1R 2TLA020072R0100
<b>Colour</b>	Yellow and black
<b>Weight</b>	155 g
<b>AS-i data</b>	
AS-i profile Urax-A1/A1R	S-7.B.E
Addressing	Jack plug
Slave address upon delivery	0
<b>Voltage supply</b>	
Voltage	AS-i yellow cable, 30 V DC. Tolerance 26.5 – 31.6 V DC.
Insulation	0 V is common with AS-i and must not be connected to the protective earth. (The AS-i voltage is floating.)
Total current consumption	<260 mA (Own consumption, sensor and outputs)
Current limit for the outputs in total	180 mA (Sensors, outputs and reset indicator)
<b>Output (non-safe)</b>	
Output voltage	24-28V DC at nominal AS-i voltage, 30V.
Current	Depending on load. See total current consumption
<b>Reaction time</b>	
Reaction time (off)*	12 ms (excluding sensors and other peripheral components)

Reaction time including Eden sensor (Normal)	<20 ms
Reaction time including Eden sensor (Worst case)	<34 ms
<b>Sensor info</b>	
Number of Eden sensors (max)	3
Cable to sensor, total length	<30 m
<b>Enclosure</b>	
Enclosure protection class	IP67
Ambient temperature	-25...+65°C
Enclosure dimensions	96x60x25 (HxWxD)
<b>Safety/Harmonised standards</b>	
IEC/EN 61508-1..7	SIL3, PFD <sub>avr</sub> : 1.5x10 <sup>-4</sup> , PFH: 1.7x10 <sup>-9</sup> , Share of SIL3: 15 % SIL3
EN 62061	Performance Level PL e, Category 4
EN ISO 13849-1	Category 4
EN 954-1	MTTFd: high
Certification	Category 4

\*NOTE: The above reaction time refers only to the Urax device. In calculating the total reaction time, all the component parts in the safety chain must be taken into account.

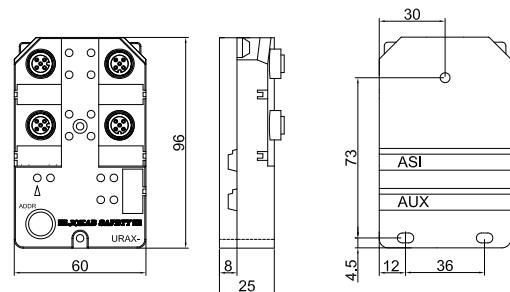

## Connections for Urax-A1 and A1R

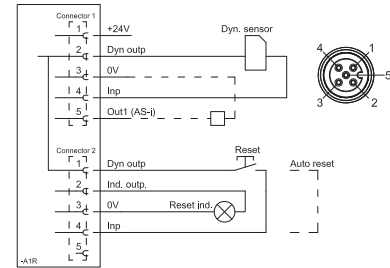
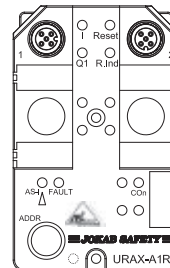
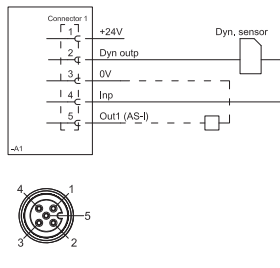
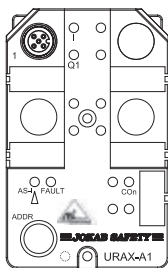

### The concept of dynamic signal

The concept is a safety circuit that is based on a single-channel dynamic signal. The dynamic signal along with the adapted sensor makes it possible to build large systems with sensors in series while maintaining the highest level of safety. The safety principle is based on each sensor inverting the signal, making it possible to detect faults such as short circuits and defective sensors.

### Odd or even number of sensors on Urax

The dynamic signal is generated in Urax and goes out to the sensors and then back again. The fact that the number of sensors may vary and that each sensor inverts the signal make it necessary for Urax-A1/A1R to be configured so that it takes into account whether it is an odd or even number of sensors that are connected to the safety loop. This is done via the AS-i node parameter settings.

### Non-safe outputs

Urax-A1/A1R is fitted with a non-safe output. This can be used for diverse control or indicators and is controlled directly from the AS-i master.

The output is located on the same contact as the safety sensor, i.e. on contact 1 and controlled on pin 5. For example, you can connect a Dalton or Knox to this contact.

### Reset

Urax-A1R has an input for local reset on contact 2 that can be configured using parameter settings for either automatic or manual reset.

#### Auto reset

If auto reset has been selected, pins 1-4 on contact 2 must be bridged.

#### Manual reset

If manual reset has been selected, the reset input must be switched on and off within 2 seconds in order for Urax to be enabled (generate safety code).

# Urax-B1R

**Approvals:**



**Application:**

Adapts dynamic sensors with higher current requirements to the AS-i bus

**Features:**

- Enables dynamic sensors on the AS-i bus
- Up to 10 sensors connected in series while maintaining the highest level of safety
- Possibility of local reset
- Outputs of non-safe control, e.g. process locks



**Adaptation device for dynamic sensors for AS-i.**

Urax-B1R is a safety node for the AS-i bus, where it is possible to connect up to ten dynamic sensors, such as Eden, in series in compliance with PL e EN ISO 13849-1.

Switches designed for dynamic safety circuit, such as Smile Tina, can also be connected.

Urax-B1R also has three outputs for non-safe control. Through these it is possible to control non-safety critical equipment such as the process lock Magne.

Urax-B1R will be supplied with an auxiliary power supply (AUX), which means that more power-consuming equipment can be connected to the node.

An additional feature is that it is possible to connect a local reset button (R) with LED indicator.

The dynamic safety sensors are controlled by Urax over one hundred times per second which gives a high level of safety.

Urax-B1R has LED indication for the dynamic loop and can be addressed on the bus via the ADDR contact.

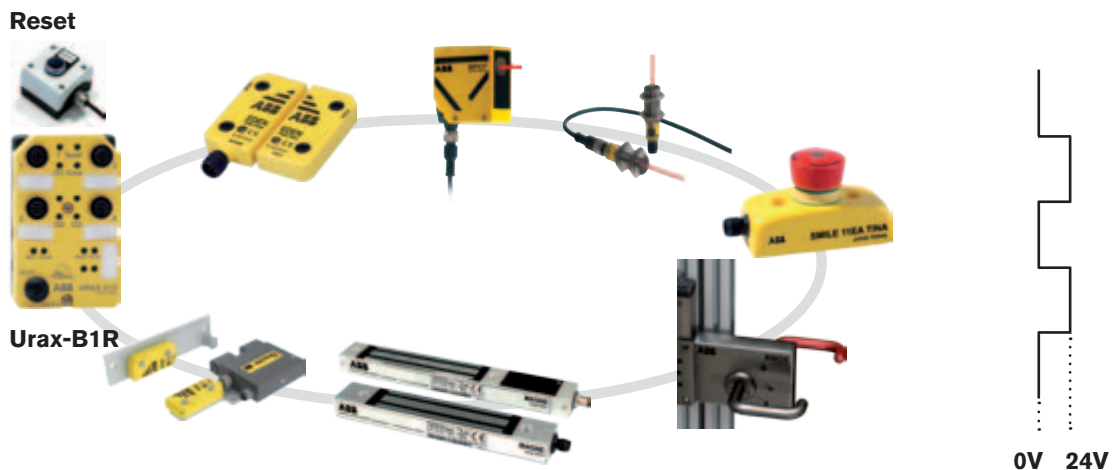

Technical data – Urax-B1R	
<b>Manufacturer:</b>	ABB AB/Jokab Safety, Sweden
<b>Part number/Ordering data:</b> Urax-B1R	2TLA020072R0200
<b>Colour</b>	Yellow and black
<b>Weight</b>	155 g
<b>AS-i data</b> AS-i profile Urax-B1R Addressing Slave address upon delivery	S-7.B.E Jack plug 0
<b>Voltage supply</b> Voltage AS-i (Yellow cable)  Voltage AUX (Black cable) Insulation  Current limit (+24 V) Total current consumption AS-i	30 V DC. Tolerance 26.5 – 31.6 V DC. 24 V DC (±15 %) 0 V is common with AS-i and must not be connected to the protective earth. (The AS-i voltage is floating.) 700 mA <30mA
<b>Output (non-safe)</b> Output voltage Current	24V DC (AUX) 700
<b>Reaction time</b> Reaction time (off)*  Reaction time including Eden sensor (Normal)	12 ms (excluding sensors and other peripheral components)  <20 ms

Reaction time including Eden sensor (Worst case)	<34 ms
<b>Sensor info</b> Number of Eden sensors (max) Cable to sensor, total length	10 <30 m
<b>Enclosure</b> Enclosure protection class Ambient temperature Enclosure dimensions	IP67 –25...+65°C 96x60x25 (HxWxD)
<b>Safety/Harmonised standards</b> IEC/EN 61508-1..7  EN 62061 EN ISO 13849-1  EN 954-1 Certification	SIL3, PFD <sub>avr</sub> : 1.5x10 <sup>-4</sup> , PFH: 1.7x10 <sup>-9</sup> , Share of SIL3: 15 % SIL3 Performance Level PLe, Category 4 MTTFd: high Category 4

\*NOTE: The above reaction time refers only to the Urax device. In calculating the total reaction time, all the component parts in the safety chain must be taken into account.

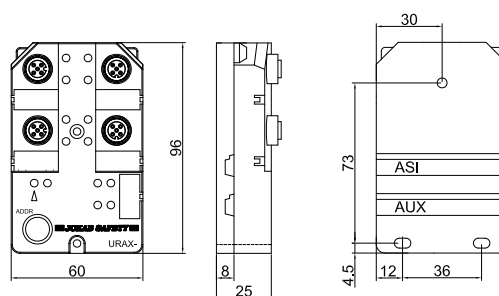

## Connections for Urax-B1R

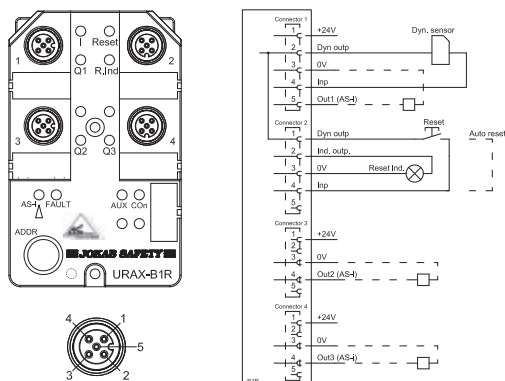

### The concept of dynamic signal

The concept is a safety circuit that is based on a single-channel dynamic signal. The dynamic signal along with the adapted sensor makes it possible to build large systems with sensors in series while maintaining the highest level of safety. The safety principle is based on each sensor inverting the signal, making it possible to detect faults such as short circuits and defective sensors.

### Odd or even number of sensors on Urax

The dynamic signal is generated in Urax and goes out to the sensors and then back again. The fact that the number of sensors may vary and that each sensor inverts the signal make it necessary for Urax-B1R to be configured so that it takes into account whether it is an odd or even number of sensors that are connected to the safety loop. This is done via the AS-i node parameter settings.

### Non-safe outputs

Urax-B1R is fitted with three non-safe outputs. These can be used for diverse controls or indicators and are controlled directly from the AS-i master. Output 1 is located on the same contact as the safety sensor, i.e. contact 1 and controlled on pin 5. For example, you can then connect a Dalton or Knox to this contact. Outputs 2 and 3 have non-safe control on pin 4 of contact 3 and 4 respectively.

### Reset

Urax-B1R has an input for local reset on contact 2 that, with parameter settings, can be configured for either automatic or manual reset.

#### Auto reset

If auto reset has been selected, pins 1-4 on contact 2 must be bridged.

#### Manual reset

If manual reset has been selected, the reset input must be switched on and off within 2 seconds in order for Urax to be enabled (generate safety code).

## Safety node

# Urax-C1/C1R

### Approvals:

TÜV Nord  

### Application:

Adapts switches/E-stop with two-channel structure to the AS-i bus

### Features:

Suitable for both normally open (NO) and normally closed (NC) contacts  
Possibility of local reset



### Adaptation device for sensors with two-channel structure on AS-i

Urax-C1/C1R is a safety node for the AS-i bus that enable the connection of switches or emergency stops. Connections can be made so that Urax-C1/C1R together with the switch comply with PL e EN ISO 13849-1.

Urax-C1/C1R is configurable depending on the switch you prefer to use. The safety node's two-channel structure works with both NO+NO and NO+NC contacts.

Urax-C1R has an additional feature that allows the connection of a local reset button (R) with LED indicator.

The safety switches' contacts are controlled by Urax each time they are actuated, for example when a door is opened and closed.

Urax-C1/C1R has LED indicators for all channels and can be addressed on the bus via the ADDR contact.

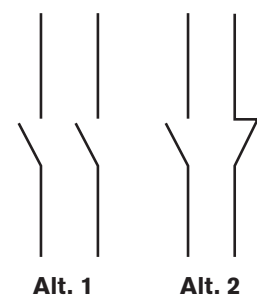



Technical data – Urax-C1 and C1R	
<b>Manufacturer:</b>	ABB AB/Jokab Safety, Sweden
<b>Part number/Ordering data:</b>	
Urax-C1	2TLA020072R0300
Urax-C1R	2TLA020072R0400
<b>Colour</b>	Yellow and black
<b>Weight</b>	150 g
<b>AS-i data</b>	
AS-i profile Urax-C1/C1R	S-0.B.0
Addressing	Jack plug
Slave address upon delivery	0
<b>Voltage supply</b>	
Voltage	AS-i yellow cable, 30 V DC (26.5 – 31.6)
Total current consumption AS-i	<150 mA
<b>Reaction time</b>	
Reaction time (off)*	12 ms (excluding sensors and other peripheral components)
<b>Enclosure</b>	
Enclosure protection class	IP67
Ambient temperature	-25...+65°C
Enclosure dimensions	96x60x25 (HxWxD)

Safety/Harmonised standards	
IEC/EN 61508-1..7	SIL3, PFD <sub>avr</sub> : 1.5x10 <sup>-4</sup> , PFH: 1.7x10 <sup>-9</sup> , Share of SIL3: 15 % SIL3
EN 62061	Performance Level PL <sub>e</sub> , Category 4
EN ISO 13849-1	MTTF <sub>d</sub> : high
EN 954-1 Certification	Category 4

\*NOTE: The above reaction time refers only to the Urax device. In calculating the total reaction time, all the component parts in the safety chain must be taken into account.

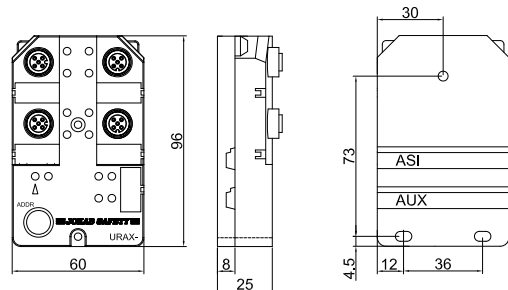

## Connections for Urax-C1 and C1R

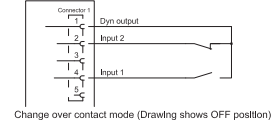
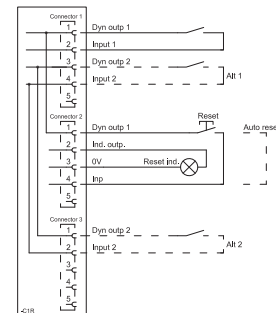
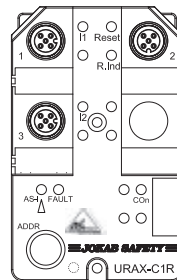
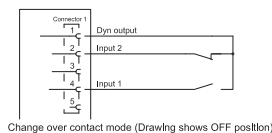
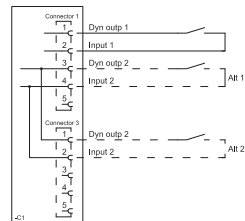
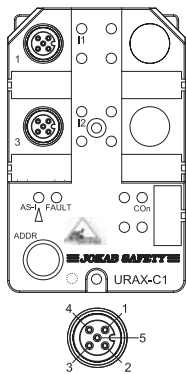

### Two-channel input

Urax-C1 is designed for safety components with two-channel switches. The channels are supplied with individual dynamic signals which enables the detection of short circuits between channels. It is possible to either connect a two-channel component exclusively to contact 1, or to connect two separate single-channel components to contact 1 and contact 3.

### Contact function, NO+NO/NO+NC

Urax-C1/C1R can work in either of the two operating modes NO + NO, with two closing contacts, or NO+NC with one closing and one opening contact. This selection is made using parameter settings.

### Filtration of contact bounce

Urax-C1R has a function to filter contact bounce ("debounce") which is active irrespective of the parameter settings. After both channels (I1 and I2) have been enabled, it is accepted for 1 second that they turn off/on. In other words, the channel monitoring is disabled during the first second after being enabled.

### Concurrency requirements

Urax-C1R also has the capability of monitoring concurrency requirements. Both channels must then change status within 2 seconds. This setting is made via the node's parametrisation.

### Reset

Urax-C1R has an input for local reset on contact 2 that can be configured using parameter settings for either automatic or manual reset.

#### Auto reset

If auto reset has been selected, pins 1-4 on contact 2 must be bridged.

#### Manual reset

If manual reset has been selected, the reset input switch must be switched on and off within 2 seconds in order for Urax to be enabled (generate safety code).



## Safety node

# Urax-D1R

### Approvals:

TÜV Nord  

### Application:

Adapts safety products with transistor outputs (OSSD) to the AS-i bus

### Features:

- Handles safety products with transistor outputs (OSSD)
- Monitors test pulses
- Possibility of local reset
- Outputs of non-safe control



### Adaptation device for sensors with transistor outputs (OSSD) for the AS-i bus

Urax-D1R is a two-channel safety input slave for the AS-i bus that enables the connection of different protection with OSSD outputs. Examples of components of this type are light curtains, light grids and scanners. Connections can be made so that the safety node together with the sensor comply with PL e EN ISO 13849-1.

The safety node is also fitted with three non-safe outputs.

Urax-D1R has an additional feature that allows the connection of a local reset button (R) with LED indicator.

Urax-D1R has LED indicators for all OSSD outputs and can be addressed on the bus via the ADDR contact.

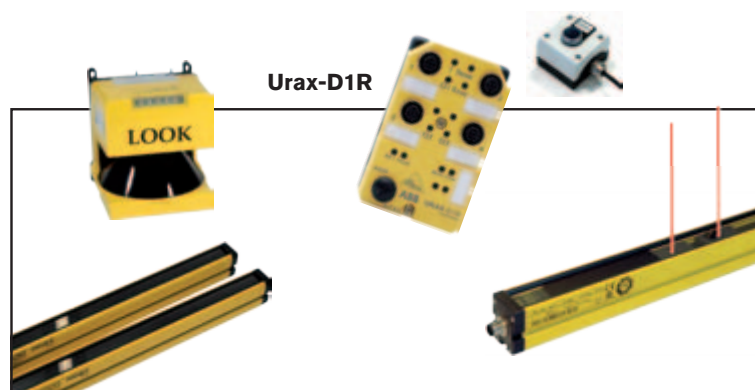

Technical data – Urax-D1R	
<b>Manufacturer:</b>	ABB AB/Jokab Safety, Sweden
<b>Part number/Ordering data:</b> Urax-D1R	2TLA020072R0500
<b>Colour</b>	Yellow and black
<b>Weight</b>	150 g
<b>AS-i data</b> AS-i profile Urax-C1/C1R Addressing Slave address upon delivery	S-0.B.0 Jack plug 0
<b>Voltage supply</b> Voltage Total current consumption AS-i	AS-i yellow cable, 30 V DC (26.5 – 31.6) <150 mA
<b>Output (non-safe)</b> Output voltage Current	24V DC (AUX) 700
<b>Reaction time</b> Reaction time (off)*	12 ms (excluding sensors and other peripheral components)

<b>Enclosure</b> Enclosure protection class Ambient temperature Enclosure dimensions	IP67 –25...+65°C 96x60x25 (HxWxD)
<b>Safety/Harmonised standards</b> IEC/EN 61508-1..7  EN 62061 EN ISO 13849-1  EN 954-1 Certification	SIL3, PFD <sub>avr</sub> : 1.5x10 <sup>-4</sup> , PFH: 1.7x10 <sup>-9</sup> , Share of SIL3: 15 % SIL3 Performance Level PLe, Category 4 MTTF <sub>d</sub> : high Category 4

\*NOTE: The above reaction time refers only to the Urax device. In calculating the total reaction time, all the component parts in the safety chain must be taken into account.

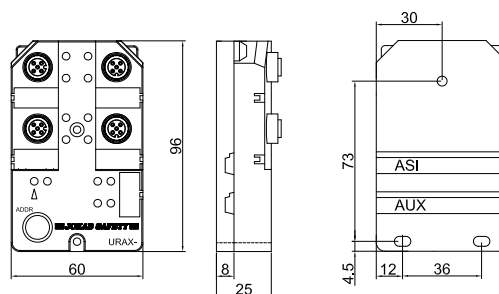

## Connections for Urax-D1R

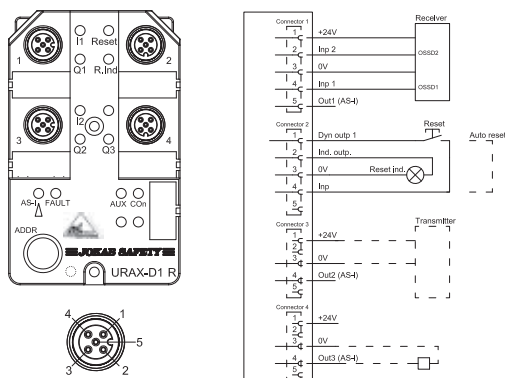

### Monitoring of short circuits (test pulses)

The safety device that connects to Urax-D1R must be capable of detecting both short circuits between the channels and short circuits to the supply voltage. These types of faults are not detected by Urax! The most common way for the safety device to detect this is by transmitting test pulses on the outputs (OSSD).

### Detection of test pulses

You can configure Urax-D1R to detect whether the test pulses are transmitted from the connected device or not (see Table, "Parameter settings and safety codes"). If Test Pulse Detection is selected, Urax will be disabled if these test pulses are missing. This feature is a safeguard against fraud.

### Non-safe outputs

Urax-B1R is fitted with 3 non-safe outputs. These can be fitted with diverse controls or indicators and are controlled directly from the AS-i master. Output 1 is located on the same contact as the safety sensor, i.e. contact 1 and controlled on pin 5. For example, you can then connect a Dalton or Knox to this contact. Outputs 2 and 3 have non-safe control on pin 4 of contact 3 and 4 respectively.

### Reset

Urax-D1R has an input for local reset on contact 2 that, with parameter settings, can be configured for either automatic or manual reset. (See table, parameter settings and safety codes.)

#### Auto reset

If auto reset has been selected, pins 1-4 on contact 2 must be strapped.

#### Manual reset

If manual reset has been selected, the reset input must be switched on and off within 2 seconds in order for Urax to be enabled (generate safety code).

## Safety node

# Urax-E1



### Approvals:

TÜV Nord  

### Application:

Adapts two-hand devices to the AS-i bus

### Features:

Handles two-hand devices with two channels

Simultaneity requirement

### Adaptation device for two-hand stations for the AS-i bus

Urax-E1 is a dual channel safety input slave to the AS-i bus, which is designed to connect the two-hand station in compliance with EN 574 model IIIC. Connections can be made so that the safety node with two-hand station complies with PL e EN ISO 13849-1.

Urax-E1 has LED indicators for all channels and can be addressed on the bus via the ADDR contact.



Urax-E1

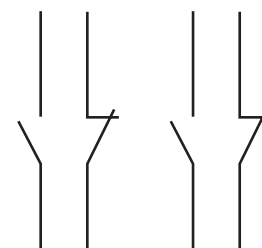
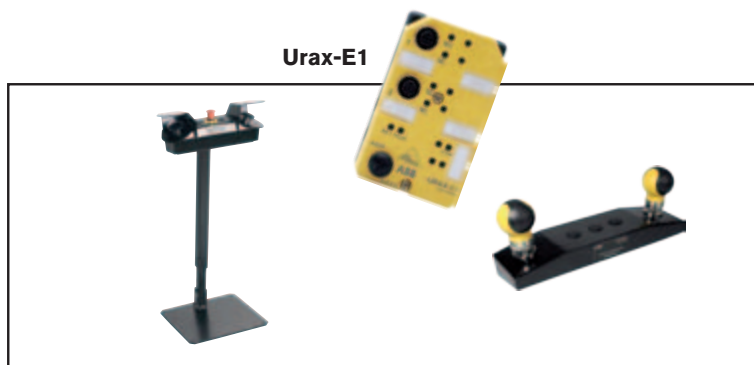

Technical data – Urax-E1	
<b>Manufacturer:</b>	ABB AB/Jokab Safety, Sweden
<b>Part number/Ordering data:</b> Urax-E1	2TLA020072R0600
<b>Colour</b>	Yellow and black
<b>Weight</b>	150 g
<b>AS-i data</b> AS-i profile Urax-C1/C1R Addressing Slave address upon delivery	S-0.B.0 Jack contact 0
<b>Voltage supply</b> Voltage Total current consumption AS-i	AS-i yellow cable, 30 V DC (26.5 – 31.6) <150 mA
<b>Output (non-safe)</b> Output voltage Current	24V DC (AUX) 700
<b>Reaction time</b> Reaction time (off)*	12 ms (excluding sensors and other peripheral components)

<b>Enclosure</b> Enclosure protection class Ambient temperature Enclosure dimensions	IP67 –25...+65°C 96x60x25 (HxWxD)
<b>Safety/Harmonised standards</b> IEC/EN 61508-1..7  EN 62061 EN ISO 13849-1  EN 954-1 Certification	SIL3, PFD <sub>avr</sub> : 1.5x10 <sup>-4</sup> , PFH: 1.7x10 <sup>-9</sup> , Share of SIL3: 15 % SIL3 Performance Level PL <sub>e</sub> , Category 4 MTTF <sub>d</sub> : high Category 4

\*NOTE: The above reaction time refers only to the Urax device. In calculating the total reaction time, all the component parts in the safety chain must be taken into account.

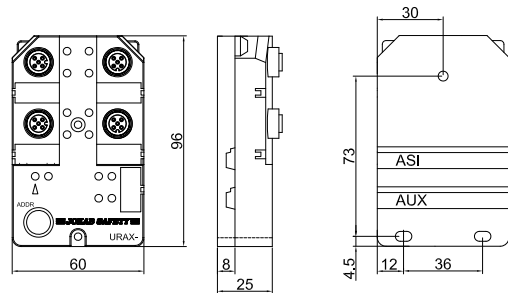

## Connections for Urax-E1

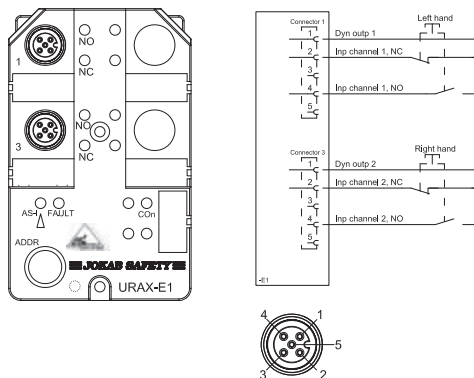

### Inputs for two-hand stations

Urax-E1 has two inputs for each hand, one for closing and one for opening contact. For safe activation (generating safety code), all four inputs are required to be enabled within 0.5 seconds. All inputs are monitored, and if Urax is disabled (stops generating safety code) this requires that all four inputs are disabled before a restart is possible. ("Open" condition for a opening (NC) contact is closed contact, and "Open" condition for a closing (NO) contact is open contact.)

Non-safe node

# Flex

## Approvals:



## Application:

Adapts non-safe products to the AS-i bus

## Features:

- 4 in and outputs to the AS-i bus
- Possibility of external power source
- LED indication



### Adaptation device for non-safe components for the AS-i bus

Through four inputs and outputs, components such as light tower or keypads are connected and controlled from the master on the AS-i bus. Flex is available in models 4A and 4B. The difference is that the B model is adapted for external power supply (700mA per connection). Flex has LED indicators for all inputs and outputs and can be addressed on the bus via the ADDR contact.

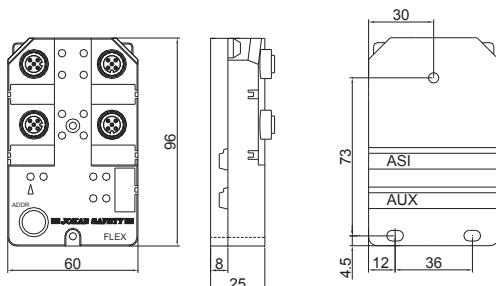

Technical data – Flex	
<b>Manufacturer:</b>	ABB AB/Jokab Safety, Sweden
<b>Part number/Ordering data:</b>	Flex-4A: 2TLA020072R5100 Flex-4B: 2TLA020072R5000
<b>Colour</b>	Grey and black
<b>Weight</b>	150 g
<b>AS-i data</b>	AS-i profile: S-7.A.E Addressing: M12 contact Slave address upon delivery: 0
<b>Voltage supply</b>	Voltage: Flex-4A: AS-i yellow cable, 30.5 VDC (26.5 to 31.6 VDC) Flex-4B: AS-i yellow cable, 30.5 VDC (26.5 to 31.6 VDC)
<b>Total current consumption AS-i</b>	FLEX-4A: Total max 185 mA (unit + connected units) FLEX-4B: Max 700 mA per pin, total max 2.8 A FLEX-4A/B (unit): 10–85 mA
<b>Reaction time</b>	Reaction time (off)*: Flex-4 separate: 5 ms Flex-4 with AS-i bus: <10 ms
<b>Enclosure</b>	Enclosure protection class: IP67 Ambient temperature: –25...+65°C Enclosure dimensions: 96x60x25 (HxWxD)





# Pluto Manager

## Programming tool for Pluto and AS-i

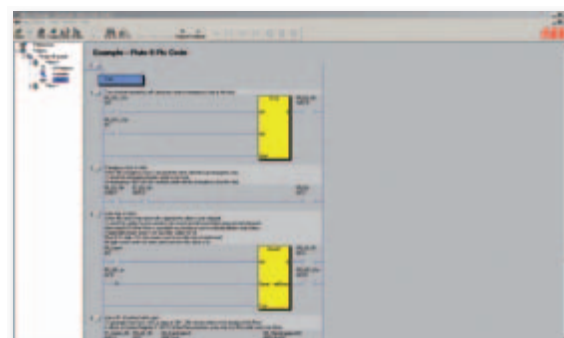

*Pluto Manager* \_\_\_\_\_ **4:2**

---

1  
2  
3  
4  
5  
6  
7  
8  
9  
10  
11  
12  
13  
14

Descriptions and examples in this book show how the products work and can be used. This does not mean that they can meet the requirements for all types of machines and processes. The purchaser/user is responsible for ensuring that the product is installed and used in accordance with the applicable regulations and standards. We reserve the right to make changes in products and product sheets without previous notice. For the latest updates, refer to [www.abb.com/lowvoltage](http://www.abb.com/lowvoltage). 2011.

Programming tool

# Pluto Manager

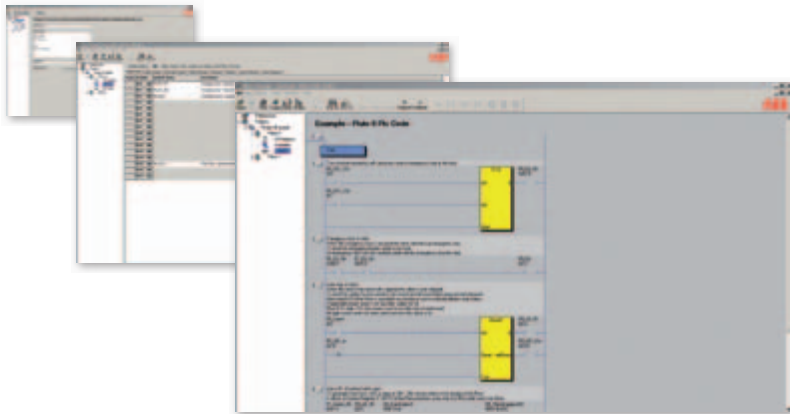

## Use:

Software for the Pluto safety PLC  
A tool to structure the safety functions

## Features:

Free software  
Downloaded from [www.abb.com/lowvoltage](http://www.abb.com/lowvoltage)  
Ready to use function blocks for your safety components  
Contains TÜV-approved function blocks  
Provides an overview of the current projects and your Plutos  
Easy programming through ladder language

### A programming tool for your safety functions

Pluto Manager is a software tailored for the safety PLC Pluto. Programming is done in ladder and together with the function block creates the structure of your safety functions. The software comes with predefined function blocks approved by TÜV to facilitate the work on designing the safety functions. Pluto Manager gives you a structured overview of Pluto's, gateways and peripheral components in large and small projects. It gives you an overview and control of the sensors and actuators, and the reactions between them. Pluto Manager also contains manuals for the software and hardware that are connected and needs to be handled through the program.

The interface gives the option to get the status directly from Pluto's two bus options, AS-i and Pluto bus. There are also diagnostic functions and the option to export data.

### Systematic working method through project management

#### Step 1 - Configuration of I/O

In every started project, each Pluto is defined individually. Its inputs and outputs are configured as desired and depending on what they connect to. Pluto's IQ ports are also configured here as inputs or outputs, dynamic or static signals.

#### Step 2 - Naming of variables

After configuration the system's variables are determined. Inputs (I), outputs (Q), remanent memories (M), global auxiliary memories for bus communication (GM) and registers (R) are given names that can be used in place of the actual variable designation in the PLC program.

#### Step 3 - Ladder programming

The program is built using the named variables connected to inputs and outputs. The programming language has a full range of instructions, similar to standard PLCs on the market, with timers, arithmetic, sequence programming etc.

The project is then downloaded to Pluto via a programming cable. This program is distributed simultaneously through bus communication to the other Plutos in the project. In this way, you need only access a single Pluto where each Pluto gets the right information specified in your project.

Pluto Manager is included when purchasing the safety PLC Pluto. The software is Windows based and can be downloaded free from [www.abb.com/lowvoltage](http://www.abb.com/lowvoltage).

## List of standards and special function blocks for Pluto Manager

The safety designer has complete freedom to program the safety functions or to use TÜV-approved pre-defined safety function blocks.

### Blocks in the standard library (func05):

1. Two-channel function with input for start
2. Two-channel function with test input
3. Two-channel function with test and reset inputs, and reset indication. See example.
4. Two-channel function with simultaneous requirement.
5. Single channel function with input for start.
6. Single channel function with start and test inputs.
7. Single channel function with reset and test inputs.
8. Two-channel function with max. time limitation (equivalent to JSHT2). Time begins to count down when both inputs are activated.
9. Two-channel function with max. time limitation (equivalent to JSHT2). Time begins to count down when one of the inputs is activated.
10. Single channel pulse function, e.g. for timed reset.
11. Two-channel pulse function, e.g. for timed reset.
12. Two single channel bypass connection functions with max. time limiting.
13. Single channel bypass connection function with max. time limiting.
14. Two-channel bypass connection function with max. time limiting and simultaneous requirement.
15. Two-channel safety function with max. time limited bypass connection.
16. Two-hand control. See example.
17. Counter which counts up to preset value.
18. Counter which counts down from preset value to 0.
19. Off delay.
20. Muting lamp\_Q16.
21. Muting lamp\_Q17.
22. Muting lamp W\_Q16. With possibility to set the power level in Watts.
23. Muting lamp W\_Q17. With possibility to set the power level in Watts.
24. Light curtain with single cycle operation.
25. Light curtain with single cycle operation and reset selection.
26. Multiplication.
27. Division.

### Other function blocks

1. Safety absolute encoder.
2. Electronic cam.
3. External communication.

### Special function blocks:

1. Program library with program block for eccentric shaft presses.
2. Custom special blocks can be made available.

### Block 3

#### TC1RTI

Two-channel function with test and reset inputs, and reset indication.

- In1 and In2 are safety inputs, to which the safety device outputs are connected.
- Test is a condition that must be true at the moment of switching on, and can be used for monitoring external components. Test must be true before the Reset input closes, i.e. the function block cannot be initiated by Test.
- Reset is a supervised reset input and must be activated (positive flank) after the other inputs have activated for the function output to be activated.
- The IndReset output is activated when the function block is 0 and flashes when the function block is ready for resetting.
- The TCfault output is activated in the case of a two-channel fault, i.e. if the function block is activated and only one of In1 and In2 opens and closes.

#### Description

The function block acts as a conventional two-channel safety relay with dual and supervised inputs (In1, In2).

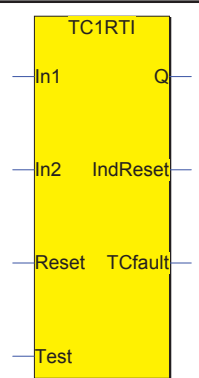

### Block 16

#### Two-hand control for devices with NO/NC + NO/NC

- Right\_NO is right handed NO contact
- Right\_NC is right handed NC contact, etc.
- The test is a condition that must be met before any of the other inputs are actuated and can be used for monitoring external components.

#### Function

In stand-by, Right\_NO must be 0, Right\_NC 1, Left\_NO 0 and Left\_NC 1. In order to start, these four inputs switch the condition within 0.5 seconds and then retain their conditions. After shutdown, all inputs must return to stand-by before any restart can be made.

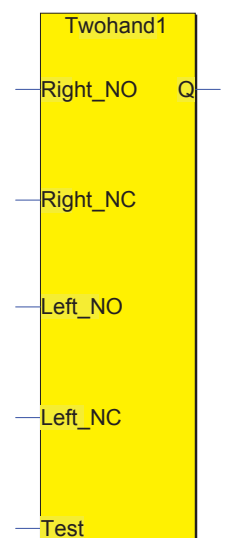



# Safety system-Vital

Supervision of dynamic safety signals.



<b>Safety system – Dynamic safety circuit – Vital-Tina</b>	<b>5:2</b>
• Number of Edens that can be used with Vital and Pluto	<b>5:4</b>
• Number of Tinas that can be used with Vital and Pluto	<b>5:5</b>
<b>Why should you use the Vital safety system?</b>	<b>5:6</b>
• How does a dynamic circuit of Vital work?	<b>5:7</b>
<b>Safety controllers Vital</b>	<b>5:8</b>
• Vital 1	<b>5:10</b>
• Vital 2	<b>5:14</b>
• Vital 3	<b>5:18</b>
<b>Why should you use the Tina adapter unit?</b>	<b>5:22</b>
• Tina is available in several variants	<b>5:23</b>
• Tina 1A – Blanking plug for connection block	<b>5:24</b>
• Tina 2A/B – Adaptation unit	<b>5:25</b>
• Tina 3A/APS – Adaptation unit	<b>5:26</b>
• Tina 4A – Connection block	<b>5:27</b>
• Tina 5A – Adaptation unit	<b>5:28</b>
• Tina 6A – Adaptation unit	<b>5:30</b>
• Tina 7A – Adaptation unit	<b>5:31</b>
• Tina 8A – Connection block	<b>5:32</b>
• Tina 10A/B/C – Adaptation unit	<b>5:34</b>
• Tina 11A – Terminal block	<b>5:36</b>
• Tina 12A – Terminal block	<b>5:37</b>
<b>Accessories</b>	<b>5:38</b>
• Example of safety sensors connections based on 'Y' branch	<b>5:39</b>
<b>Connection examples - Vital and Tina</b>	<b>5:40</b>

Descriptions and examples in this book show how the products work and can be used. This does not mean that they can meet the requirements for all types of machines and processes. The purchaser/user is responsible for ensuring that the product is installed and used in accordance with the applicable regulations and standards. We reserve the right to make changes in products and product sheets without previous notice. For the latest updates, refer to [www.abb.com/lowvoltage](http://www.abb.com/lowvoltage). 2011.

# Safety system

## Dynamic safety circuit – Vital-Tina

**Vital** is a safety controller with a dynamic safety circuit that can monitor up to 30 sensors, such as Eden, in accordance with the highest safety level. The safety loop can be expanded by using Tina Duo. Vital has selectable manual or automatic resetting and dual outputs. (The Pluto safety PLC has many inputs for dynamic safety circuits.)

### Active safety sensors for dynamic safety circuits



Patented solution



Safety circuit category up to PL e according to EN ISO 13849-1

### Tina units that convert static/OSSD to dynamic signals



**Dynamic safety**  
Dynamic “twinned” safety signal that tests a sensor, for example, 200 times per second.

0V 24V

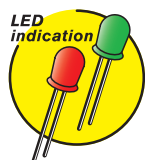

Each active sensor and Tina unit has LEDs that indicate OK (green), broken safety circuit (red) or flashing if the loop has been broken by another, earlier, sensor.

### Sensors with static or OSSD outputs that are connected via Tina units



## Vital is available in three variants

### Vital 1

Dynamisk krets 1

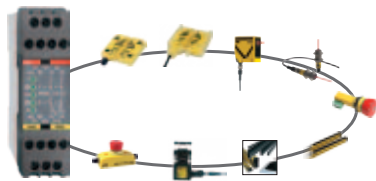
- Up to 30 sensors can be connected to the same dynamic safety circuit

### Vital 2

Dynamisk krets 1      Dynamisk krets 2

- Two safety circuits are monitored by one module
- Simple system with extensive functionality
- Up to 10 sensors can be connected to each dynamic safety circuit
- Output group 2 can be set for time delay
- Three different modes of operation

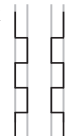
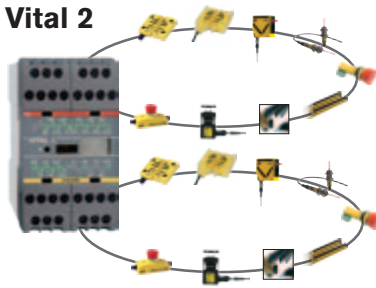
### Vital 3

Kontakt krets 1      Dynamisk krets 2

- Two safety circuits are monitored by one module
- Devices with two-channel, opening contacts can be connected to one circuit
- Simple system with extensive functionality
- Output group 2 can be set for time delay
- Three different modes of operation

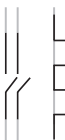
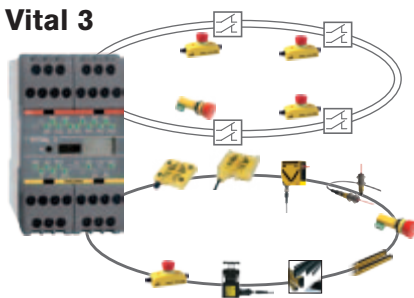
## One Vital supervises the entire robot cell!

This example shows a cell that consists of dynamic protection sensors connected to a Vital with the following functions:

### Two charging stations

At each charging station a light curtain checks for anyone putting their hand into a risk area, and an Eden sensor checks whether a robot is inside the same risk area. This means that a stop is only ordered if a robot and a person are in the same area. When the station is clear, the person presses the reset button connected to the light curtain.

### Fence with Eden-interlocked door

If the door is opened, the robot stops. To reset the robot system, the door must be closed and a supervisory reset button operated.

### Three emergency stops with Tina units

If any of the emergency stop buttons is pressed, the robot performs an immediate emergency stop.

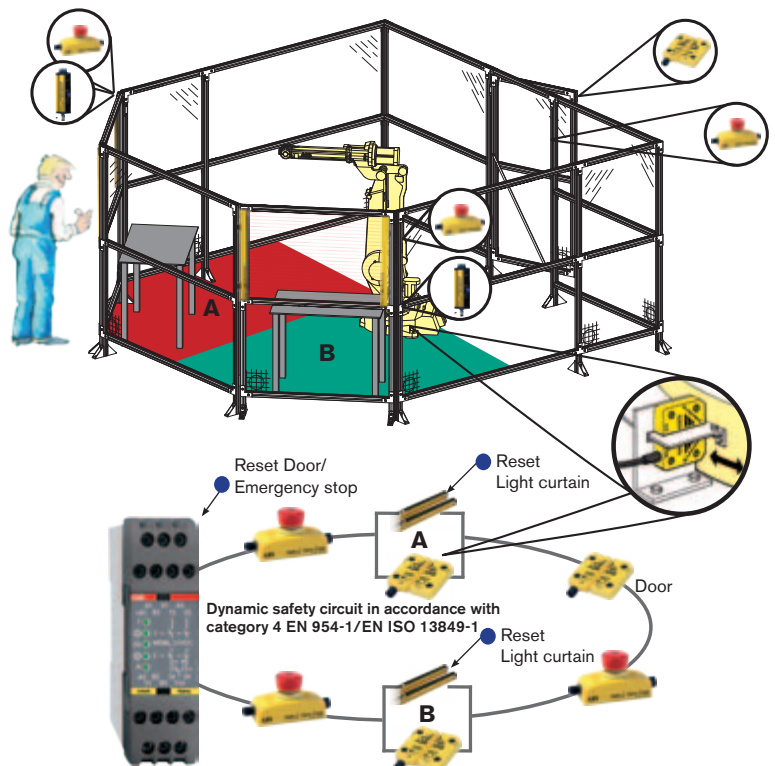

# Number of Edens that can be used with Vital and Pluto

The tables below show the number of Edens that can be connected to Vital and Pluto with the maximum voltage variation. The values have been established in a laboratory environment. The actual possible number of connected Edens may therefore differ from those given in the table. The values should be regarded as guidelines; ABB Jokab Safety recommends a maximum of 30 Edens per Vital 1 and a maximum of 10 Edens per Pluto and Vital 2/3 input. The table was prepared according to measurements with connection example A. If connection example B and 0.34 mm<sup>2</sup> cable is used (with feed voltage from two directions), the values for 0.75 mm<sup>2</sup> in the tables are used.

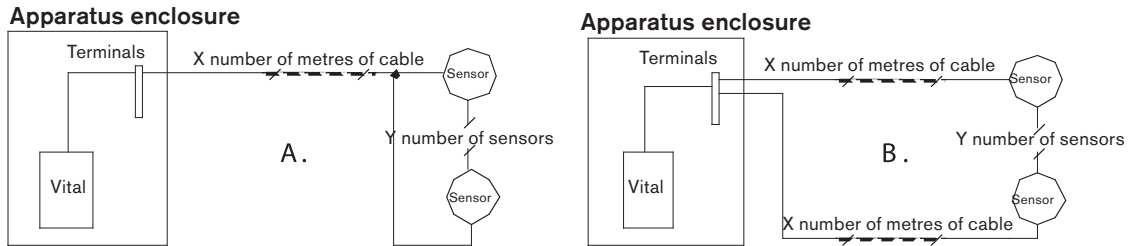

## Number of Edens that can be used with Vital 1

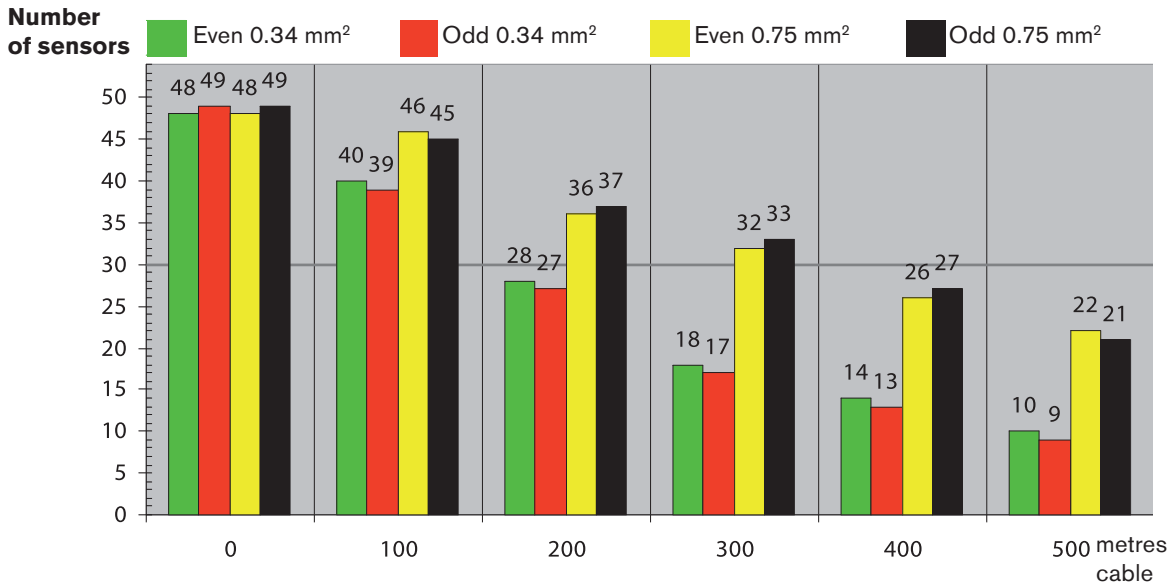

## Number of Edens that can be used with Pluto and Vital 2/3

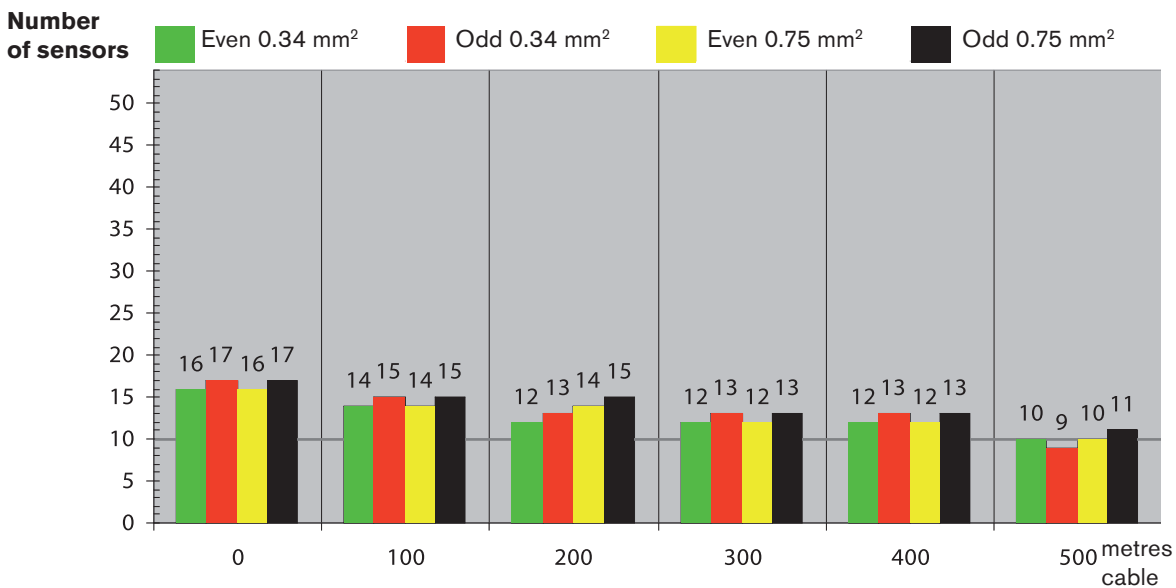



# Number of Tinas that can be used with Vital and Pluto

The following tables show the numbers of Tina-3A, Tina-6A, Tina-7A and SmileTina that can be connected to Vital and Pluto with the max voltage variation. The values have been established in a laboratory environment. The actual possible number of connected units may therefore differ from those given in the table. The values should be regarded as guidelines; ABB Jokab Safety recommends a maximum of 30 units per Vital 1 and a maximum of 10 units per Pluto and Vital 2/3 input. The table was prepared according to measurements with connection example A. If connection example B and 0.34 mm<sup>2</sup> cable is used, the values for 0.75 mm<sup>2</sup> in the tables are used.

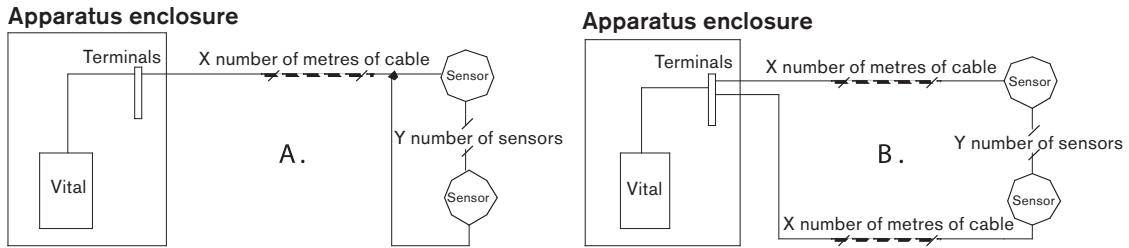

**Number of Tina-3A, 6A, 7A and Smile Tinas that can be used with Vital 1**

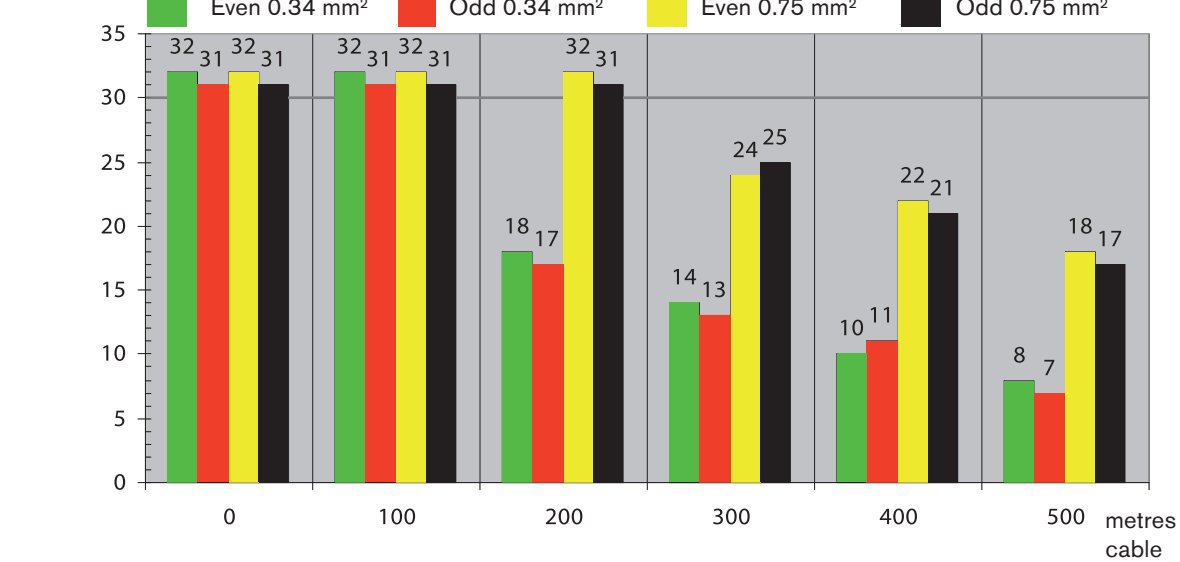

**Number of Tina-3A, 6A, 7A and Smile Tinas that can be used with Pluto and Vital 2/3**

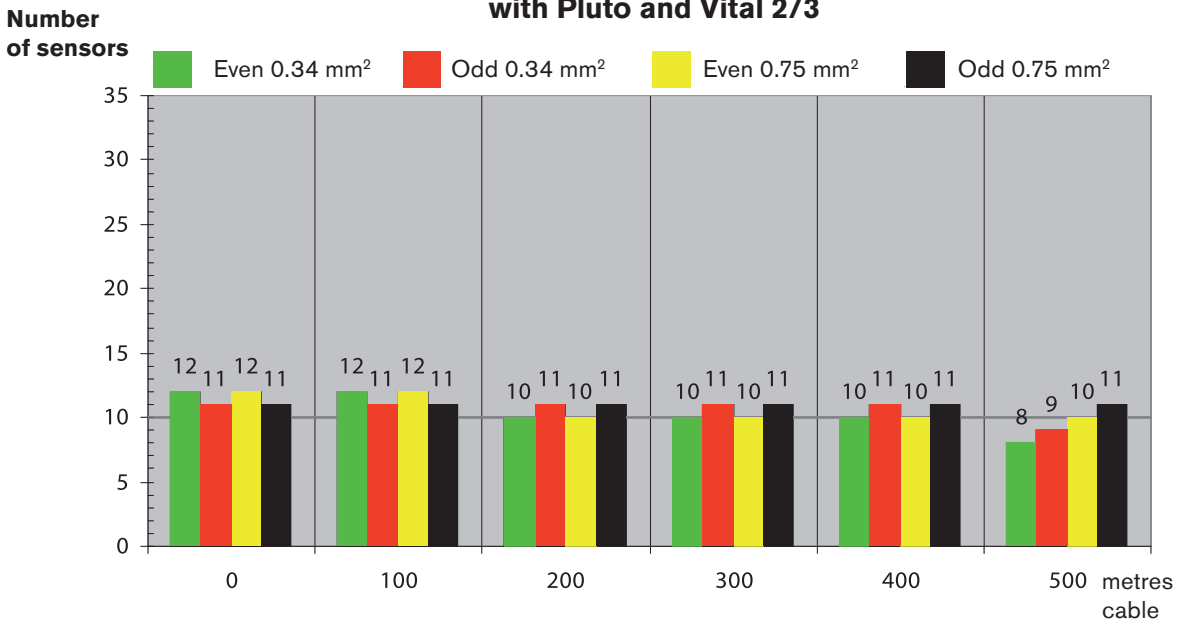

# Why should you use the Vital safety system?



## - To be able to connect several safety components in series (at category 4) and supervise them with only one safety controller!

Vital is the heart of a solution which makes it possible to install/connect many different types of safety device in the same safety circuit and still achieve PL e according to EN ISO 13849-1. The Vital module is based upon a dynamic single-channel concept as opposed to conventional dual-channel safety relays. **Up to 30 dynamic sensors can be connected directly in the safety circuit and be supervised by only one Vital module.** The Vital therefore replaces several safety relays. Safety components with output contacts can be connected to the Vital via low cost Tina adaptors.

The Vital also has automatically or manually supervised reset selection, dual safety outputs, and an information output for reset indication and status information for PLC's.

## - To supervise safety components!

Most safety components on the market can be connected to the Vital module. Dynamic sensors enable safety PL e to be achieved in a single-channel system. For example ABB Jokab Safety's dynamic non-contact Eden sensor, Spot light beam and emergency stops (via Tina adaptors) can be used. Even mechanical switches can be connected to Vital with the aid of ABB Jokab Safety's Tina adaptors.

## - For easy installation and assembly of a safety system!

Vital is a small electronic safety controller that dynamically supervises a number of safety components. Vital's detachable connector blocks simplify the connection, trouble-shooting and exchange of modules. The Vital and other safety components can be connected together using standard cables and with cables having M12 connections.

## - why should you choose Vital?

- PL e, according to EN ISO 13849-1 dynamic safety circuit
- Can accommodate long cable lengths
- Manually supervised or automatic reset
- Two NO safety outputs
- Detachable connector blocks
- LED indication of: power supply, dynamic signal and outputs
- Information output with two functions
- Cost-effective cable routing/connections

## How does a dynamic circuit of Vital work?

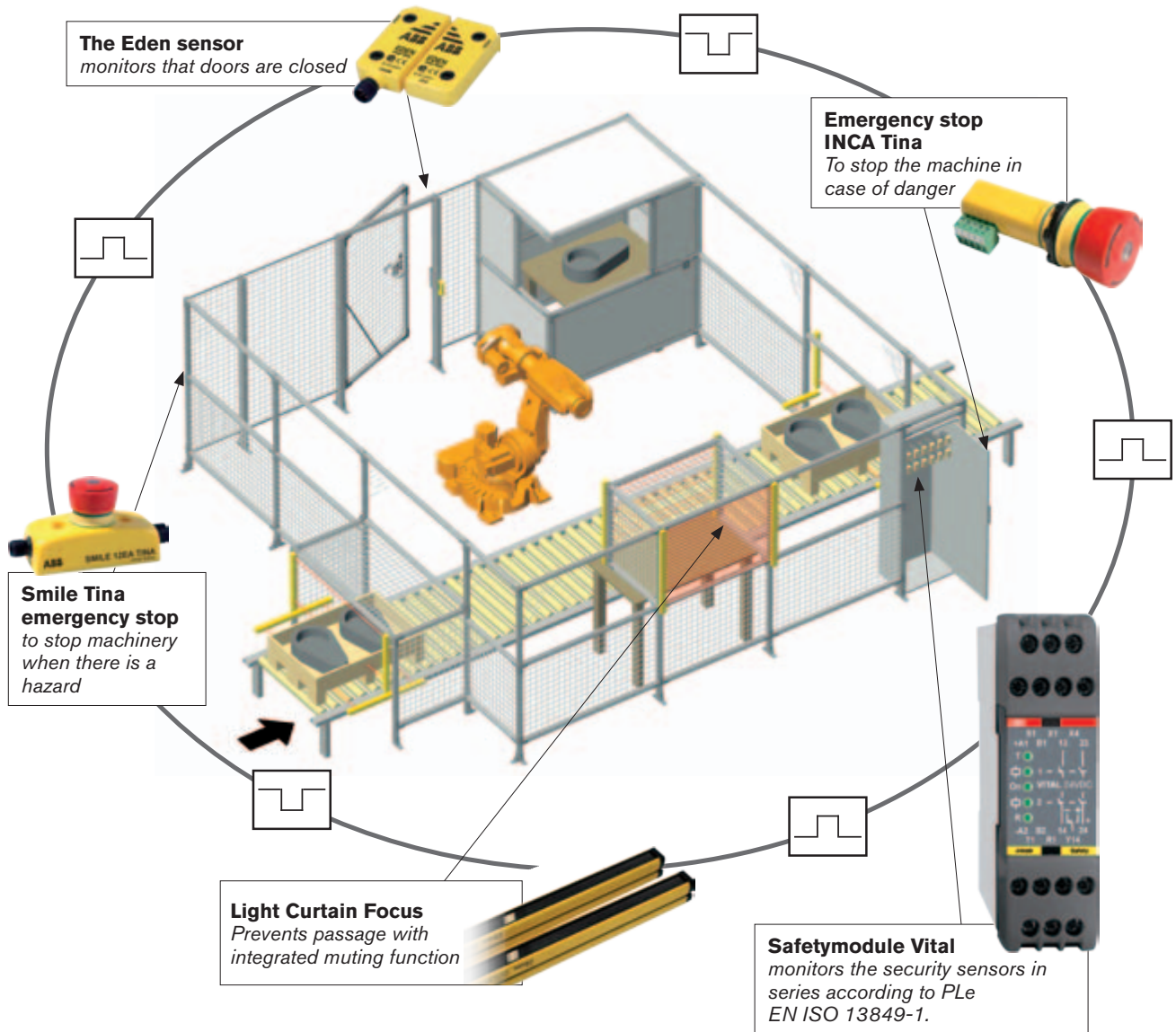

The dynamic signal consists of a square wave that is transmitted through the safety circuit. The signal is inverted at each safety component and is monitored 200 times per second by Vital or Pluto.

The dynamic signal is transmitted as single channel throughout all the protection in the same safety circuit between input terminals T1 and R1. If a protection breaks, the dynamic signal is not transmitted which is detected by Vital which breaks its safe outputs. Even short circuits across a protection are detected when the signal is inverted in each sensor (the protection is then OK), while Vital expects a

correctly inverted signal at the right time. In this case, an even number of sensors are connected to the safety loop which means that the dynamic signal will be inverted an even number of times when it is evaluated by Vital. This is determined by the terminal inputs S1 and B1 being connected together. If an odd number of sensors have been connected, connection of S1 is not required. As the signal is evaluated by Vital at each pulse, i.e. more than 200 times per second, faults and short circuits are detected within a few milliseconds.

# Safety controller

# Vital



Vital is based on a single channel safety concept where multiple safety sensors can be connected in series and monitored with a single safety controller. A dynamic signal is sent from Vital through all connected sensors, and then returned to Vital which then evaluates the received signal. As each safety sensor inverts the signal, it is possible to detect short circuits or faults in any of the sensors. Vital 2 and Vital 3 are designed for use with ABB Jokab Eden sensors, Tina components and Spot light grids or similar products. Vital 2 and 3 are both safety controllers with two safe input functions and two output groups, the only difference between the two models being in the input configuration.

## Approvals:

TÜV Nord – Vital 1  
TÜV Rheinland – Vital 2 and 3



## Control of:

Entire safety system based on the dynamic safety circuit.

## Features:

- Easy installation
- Flexible
- Cost effective
- Display for troubleshooting (Vital 2 and 3)
- A wide range of safety sensors can be connected into the circuit
- Several safe outputs
- Information output
- Outputs with time delay (Vital 2 and 3)





# Reset connections – Vital 1

## Manually supervised reset

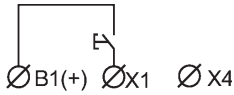

The manually supervised reset contact connected to input X1 must be closed and opened in order to activate the relay outputs.

## Automatic reset

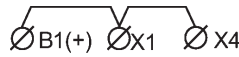

Automatic reset is selected when B1, X1 and X4 are connected. The relay outputs are then activated at the same time as the inputs.

## Testing external contactor status

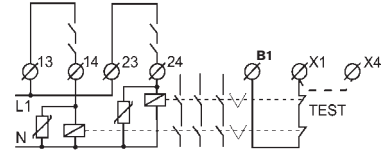

Contactors, relays and valves can be supervised by connecting 'test' contacts between B1 and X1. Both manually supervised and automatic reset can be used.

# Output connection – Vital 1

## Relay outputs

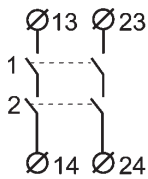

The Vital 1 has two (2 NO) safety outputs. In order to protect the output contacts it is recommended that loads (inductive) are suppressed by fitting correctly chosen VDR's, diodes etc. Diodes are the best arc suppressors, but will increase the switch-off time of the load.

## Connection of S1

Even number of units in series (Eden+Spot+Tina) requires a connection between B1 and S1. S1 is not connected at odd number of units.

See drawing below figure A and other examples in the book

## Information outputs

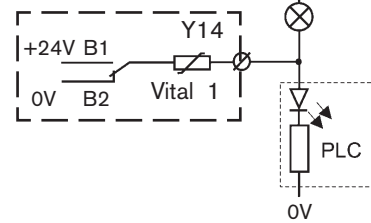

Vital 1 has a switching relay output for information. The function is determined by a DIP switch.

The DIP switch position 1 (original position) is the information output Y14 internally connected to 0V and +24 V as per:

- Y14 is closed to 0V (B2) internally when Vital 1 has not been reset.
- Y14 is closed to +24 V (B1) when Vital 1 has been reset.

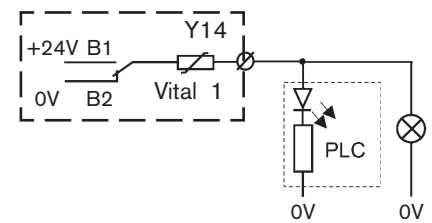

In DIP switch position 2 (the purpose of the function is to start/restart block, RES) the information output Y14 is internally connected to 0V and +24 V as per:

- Y14 is internally closed to 0V (B2) when the dynamic safety loop is open or when the dynamic safety loop is closed and Vital 1 has been reset.
- Y14 is internally closed to +24 V (B1) when the dynamic safety loop is closed but Vital 1 has not been reset (RES).

# Connection examples of safety devices to Vital 1

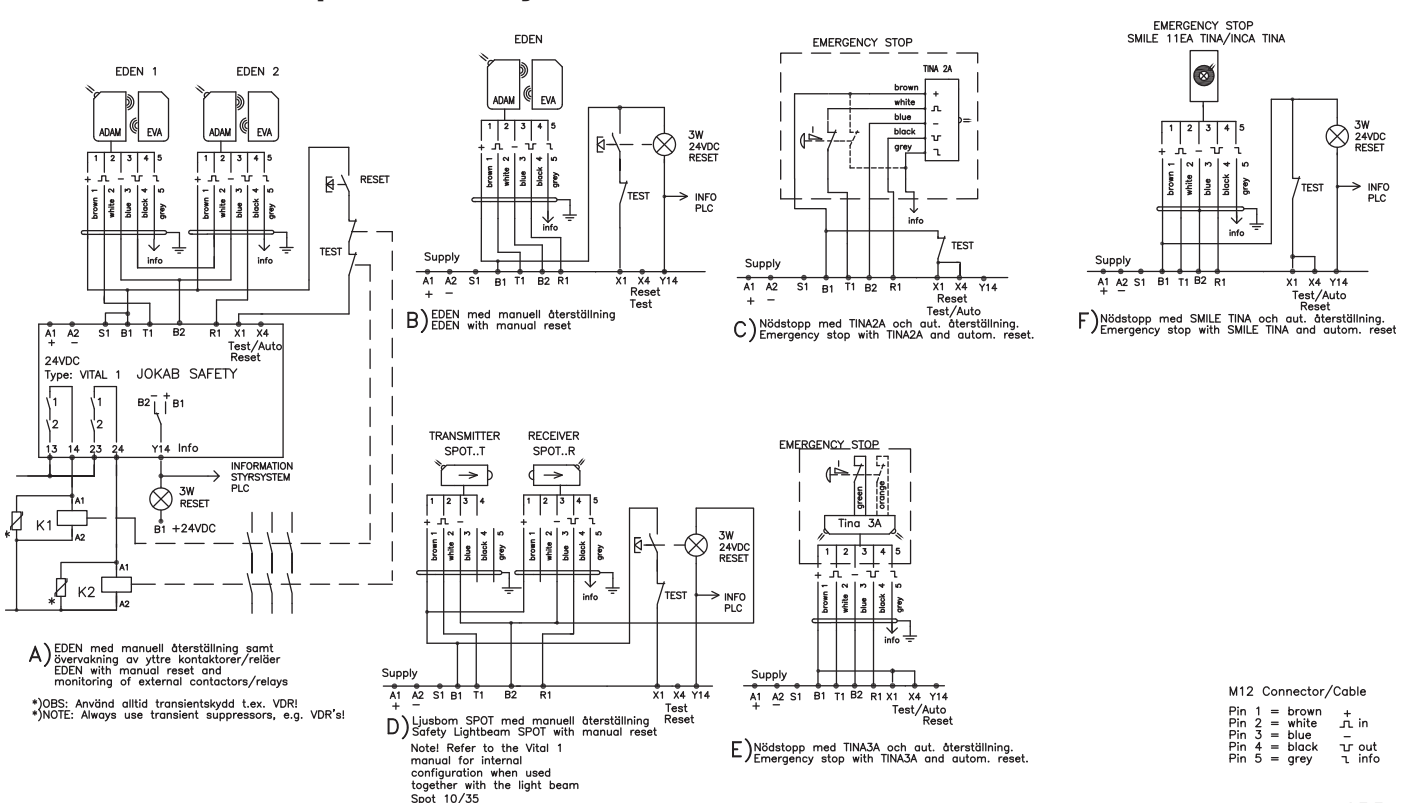



Technical data – Vital 1	
<b>Manufacturer</b>	ABB AB/Jokab Safety, Sweden
<b>Article number/Ordering data:</b> Vital 1	2TLA020052R0000
<b>Level of safety</b> EN ISO 13849-1 EN 62061 IEC/EN 61508-1...7 EN 954-1	PL e, category 4 SIL 3 SIL 3 Category 4
<b>PFH<sub>d</sub></b>	1,01 × 10 <sup>-8</sup>
<b>Colour</b>	Grey
<b>Weight</b>	220 g
<b>Power supply</b> Vital, A1-A2 From Vital to sensors/units, B1-B2	24 VDC ±15% 24 VDC
<b>Fuse</b> An external fuse should be fitted in the supply to A1	3 AT
<b>Max line resistance</b> at nominal voltage to X1	150 Ohm
<b>Power consumption</b> DC supply, nominal voltage (without load) DC supply, nominal voltage (with max load)	3 W 48 W
<b>Dynamic safety circuit</b> T 1 R 1	Output signal Input signal
<b>Reset input X1</b> Supply for reset input Reset current  Minimum contact closure time for reset	+24VDC 30 mA max. (inrush current 300 mA during contact closure)  80 ms
<b>Connection of S1</b> Even numbers of sensors (Eden + Spot T/R + Tina) require a connection between B1 and S1. S1 is not connected for odd numbers of sensors. Odd number, no connection between B1 and S1.	
<b>Number of sensors</b> Max. number of Eden/Tina to Vital 1 Total max. cable length to Eden/Tina Max. number of Spot T/R to Vital Total max. cable length to Spot T/R	30 1000 m 6 pairs 600 m
Maximum number of units varies depending on the installation and cable size. For more information, see the examples in this chapter.	
<b>Response time</b> At Power on When activating (input-output) When deactivating (input-output) At Power loss	< 65 ms < 40 ms < 38 ms < 45 ms
<b>Relay outputs</b> NO Max switching capacity, resistive load  Minimum load Contact material Mechanical life External fuse (EN 60947-5-1)	2  6A/250 VAC/1500 VA/150W  10 mA/10V AgCdO >10 <sup>7</sup> operations 6.3A or 4A slow

<b>Relay information output (changeover contact)</b> Y14 –(0V) +(24V) Max. load on Y14	Indicates Vital is not reset Indicates Vital is reset 200 mA (Internal automatic fuse)
<b>LED indication</b>           On ●  T ● R ● ☐ ● 1 ☐ ● 2	Fixed light: supply voltage OK, Flashing light: under-voltage or overload. T: Signal out OK. R: Signal in OK. Indicates that the output relays have been activated
<b>Mounting</b> DIN rail Operating temperature range	35 mm DIN rail -10°C to + 55°C
<b>Connection blocks (detachable)</b> Max screw torque Max connection area: Solid conductors Conductor with socket contact Air and creep distance	1 Nm  1x4 mm <sup>2</sup> /2x1,5 mm <sup>2</sup> /12AWG 1x2,5 mm <sup>2</sup> /2x1 mm <sup>2</sup> 4kV/2 DIN VDE 0110
<b>Protection class</b> Enclosure Connection blocks	IP 40 IEC 60529 IP 20 IEC 60529
<b>Conformity</b>	EN ISO 12100-1, -2, EN 954-1, EN ISO 13849-1, EN 62061, EN 60204-1, IEC 60664-1, EN 61000-6-2, EN 61000-6-4 EN 60947-5-1, EN 1088, EN 61496-1, IEC/EN 61508-1...7

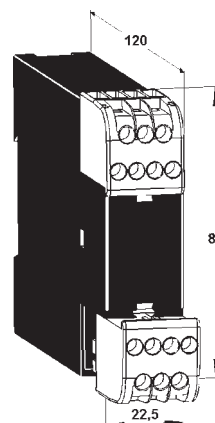

Connector blocks are detachable (without cables having to be disconnected)

# Connection of units and cable lengths to Vital 1

CONNECTION EXAMPLE VITAL1 SOLUTIONS

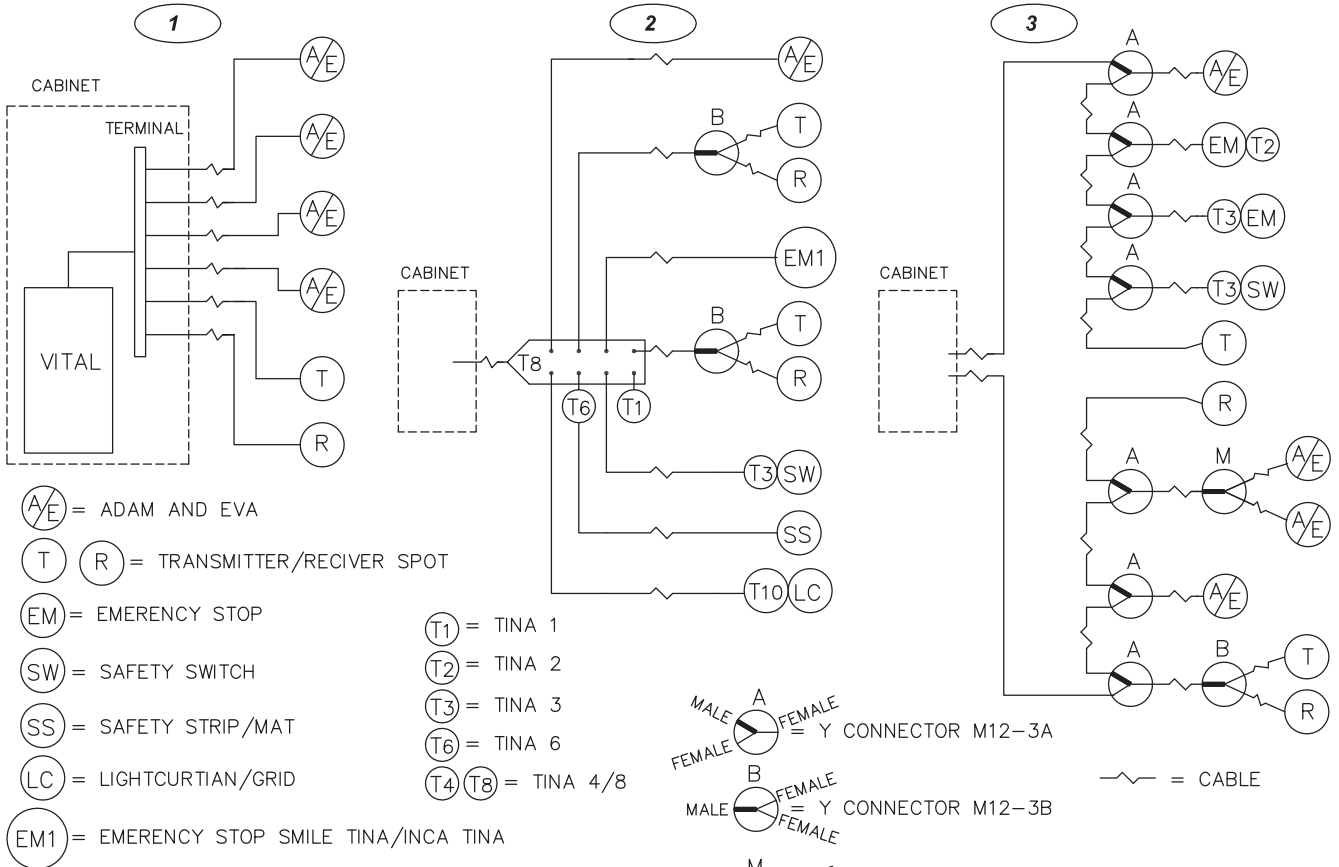

INFORMATION IS AVAILABLE VIA CABLE FROM EACH SENSOR IN EX. **1** AND **2**

HH3400A2

### Three connection alternatives

According to PL e (EN ISO 13849-1), connection of sensors/adaptor units in the Vital safety circuit **must be made as the connection examples.**

#### Example 1

Use separate connection cables from each sensor/adaptor unit to the Vital safety controller. Interconnections to be made via suitable terminals in the control cabinet.

#### Example 2

Use Tina4A/Tina8A connector blocks to simplify the connection of externally mounted sensors/adaptor units. Only Tina4A/Tina8A connector blocks may be used. **Use of any other connector blocks will not meet the safety circuit requirements.**

#### Example 3

Use M12-3A and M12-3B 'Y' connectors to connect sensors in series/parallel.

### Cable lengths and number of sensor/adaptor units for the three connection examples.

In order to determine the number of sensor/adaptor units that can be connected to a Vital 1 unit it must be remembered that 1 (one) Spot T/R is equivalent to 5 (five) Eden or Tina units. Units in parallel are equal to one unit. The following examples provide **guidance** as to possible configurations and cable lengths using suitable cables.

#### Example 1

Up to 1000 metres (0.75 mm<sup>2</sup> or 0.34 mm<sup>2</sup> conductors) in total can be connected to the sensors/units in this example. The connection is equivalent to 9 Eden or Tina units.

A maximum of 30 Eden or Tina units can be connected to the Vital 1 unit on a maximum cable length of 500 metres (0.75 mm<sup>2</sup> conductors) or 300 metres (0.34 mm<sup>2</sup> conductors).

#### Example 2

Up to 600 metres (0.75 mm<sup>2</sup> conductors) to Tina 8A and 10 metre cables type M12-C1012 (0.34 mm<sup>2</sup>) to each sensor/unit connected to the Tina 8A. This connection example is equivalent to 17 Eden or Tina units.

A maximum of 3 Tina 8A units, equivalent to 27 Eden/Tina units (= 3 x 8 connected to Tina 8A + 3 Tina 8A) can be connected to one Vital 1 with a total cable length of 600 metres (0.75 mm<sup>2</sup>). Up to 6 Tina 4A units can be connected to one Vital 1 (equivalent to 30 Eden/Tina units) with a total cable length of 600 metres (0.75 mm<sup>2</sup>) to Tina 4A.

#### Example 3

Either 2 x 500 metre cables (0.75 mm<sup>2</sup>) from the control cabinet and 10 metre cables (0.34 mm<sup>2</sup>) to each sensor/unit or 2 x 10 metre cables (0.75 mm<sup>2</sup>) from the control cabinet and 200 metre cables (0.75 mm<sup>2</sup>) to each sensor/unit. The connection is equivalent to 16 Eden or Tina units.

A Total of 30 Eden/Tina units can be connected using a maximum cable length of 1000 metres (0.75 mm<sup>2</sup>) or 400 metres (0.34 mm<sup>2</sup>). If the power supply is only fed from one direction (from one end of the network) the total cable length is reduced to approx 300 metres (0.75 mm<sup>2</sup>) and 100 metres (0.34 mm<sup>2</sup>).

### Connection advice for dynamic sensors to Pluto and Vital.

Sensors can be connected in many different ways. Here is some advice that can make connection better and more stable. The advice is general, but particularly applicable to the use of Tina 4A and Tina 8A units.

- Never have more than the recommended number of sensors in the loop.
- If possible use a switched mains power supply that can deliver a stable 24 V DC.
- In the sensor system, use as short cables as possible.
- When connecting a Tina 4A or Tina 8A unit, the supply voltage at the terminal (out at the unit) must not be less than 20 Volts.
- Use screened cable, preferably 0.75 mm<sup>2</sup> or thicker, from the apparatus enclosure and ground it at one end, for example at the apparatus enclosure, not at both ends.
- Do not route the signal wiring close to heavy current cabling or close to equipment that gives off a lot of interference, such as frequency converters for electric motors.
- Never connect "spare" conductors.
- If M12-3B are used for connection of a parallel loop, with supply to the sensors from two directions, the loop must be as short as possible. This is because the conductors that are not being used are also connected, which increases the capacitive load and reduces the stability of the system.

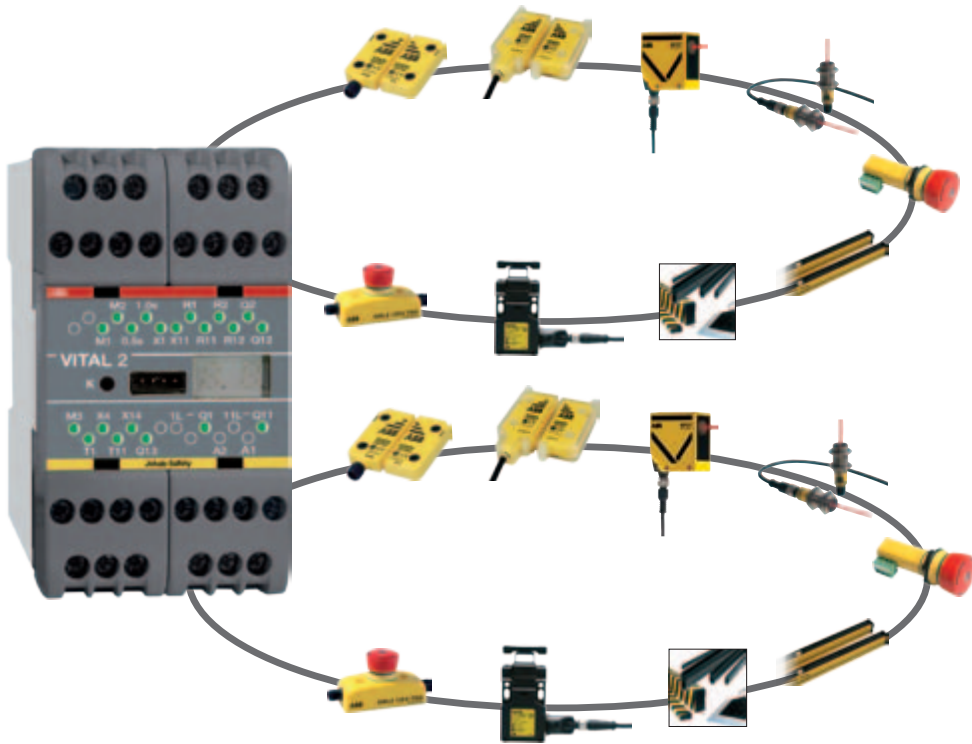

Vital 2 is a safety controller that combines functionality with the quick and easy installation of safety sensors. With two safe input functions and two different output groups, Vital 2 offers the capability to exclusively control smaller machine safety systems that would otherwise have required a programmable controller or multiple safety relays. How the two output groups are controlled by the input functions depends on which of the three operating modes is selected (see Selection of operating mode).

**Input function 1:**

A dynamic safety circuit where ABB Jokab Safety's safety sensors such as Eden, Tina and Spot can easily be connected in series. Up to 10 Eden or Tina devices can be connected in series per input function.

**Input function 2:**

The same function as input function 1.

**Output group 1:**

A safe relay output in a duplicated series and a safe transistor output with output voltage of -24 VDC.

**Output group 2:**

A safe relay output in a duplicated series and a safe transistor output with output voltage of -24 VDC. In addition, output group 2 contains a non-safe transistor output with output voltage of +24 VDC, intended for information. The output group can have time delay from 0 to 1.5 s.

**Selection of operating modes**

Vital 2 can be configured to operate in one of three operating modes M1, M2 or M3. The selection of operating modes is done by connecting one of the terminals M1, M2 or M3 to +24 V.

## Operating mode M1 - Separate function Vital 2

Input function 1 controls output group 1, and input function 2 controls output group 2.

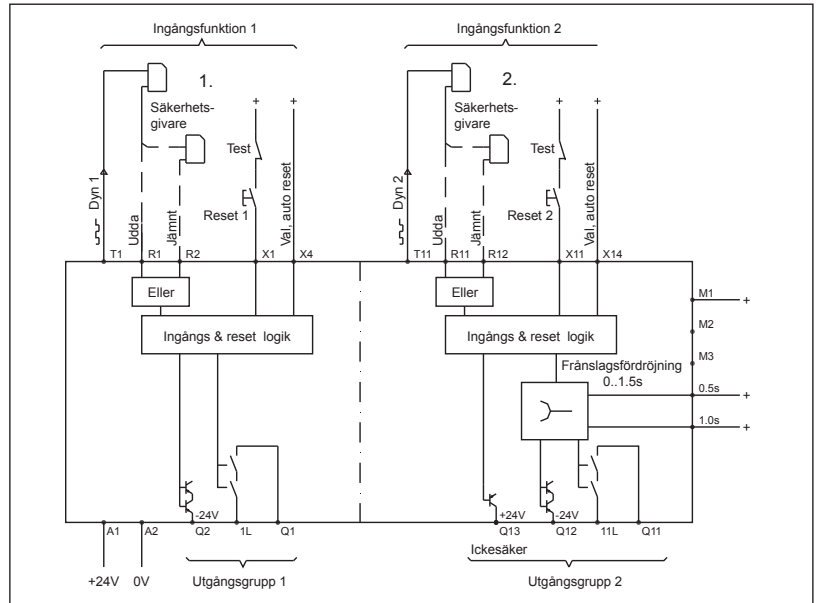

## Operating mode M2 - Input 1, master function Vital 2

Input function 1 stops all outputs, and input function 2 stops output group 2.

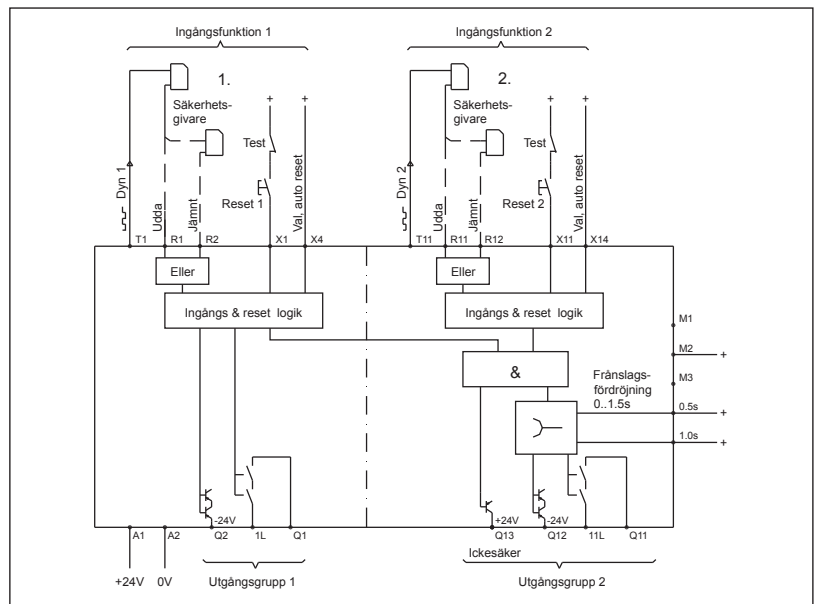

## Operating mode M3 - Parallel function Vital 2

Input function 1 and input function 2 operate in parallel and control all outputs. Reset/Auto reset 1 resets both input functions (Reset/Auto Reset 2 is not used).

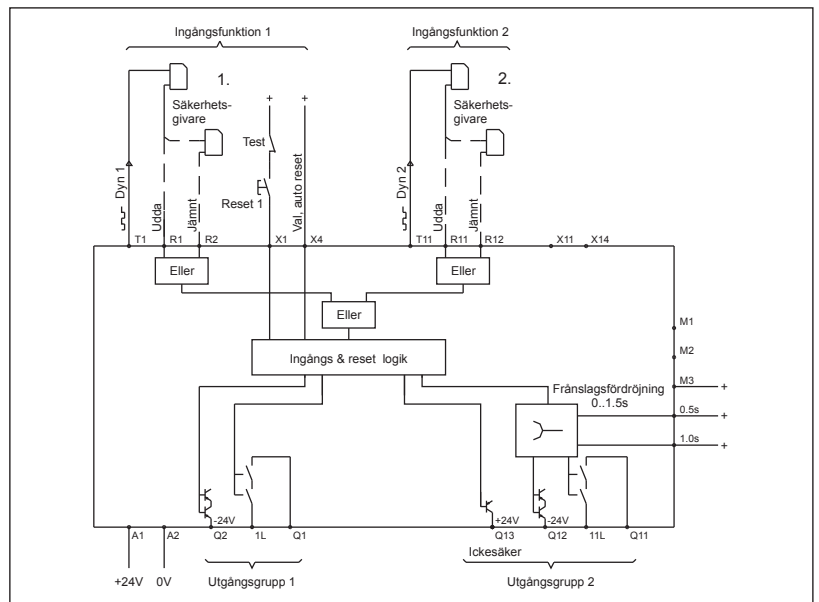

## Connection of protection/sensors - Vital 2

Depending on the input function and the number of sensors connected to the safety circuit (odd or even number), the dynamic signal is connected between different terminals;

### Input function 1:

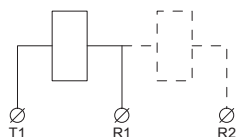

A dynamic signal is transmitted from T1, and depending on the number of sensors in the safety circuit, the signal connects back to R1 (odd number of sensors) or R2 (even number of sensors).

### Input function 2:

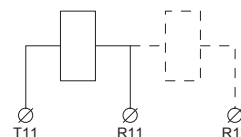

A dynamic signal is transmitted from T11, and depending on the number of sensors in the safety circuit, the signal connects back to R11 (odd number of sensors) or R12 (even number of sensors).

## Connection of outputs - Vital 2

### Connection of safe transistor output (-24 V)

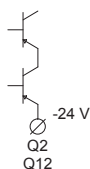

The safe transistor outputs Q2 (output group 1) and Q12 (output group 2) have an output voltage of -24 V.

### Connection of safe relay output

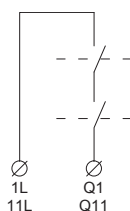

The safe relay outputs that are duplicated in series break between 1L-Q1 (output group 1) and 11L-Q11 (output group 2). The loads that break should be fitted with spark arresters to protect the outputs. The correct selection of VDR circuit, RC circuit or diode is appropriate. Note that the diode extends the disconnection time of the load.

### Connection of information output

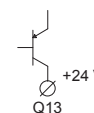

The non-safe transistor output Q13 is high (+24 V) when the outputs from output group 2 are active. The function is therefore dependent on the operating mode selected (see Selection of operating mode).

## Connection of reset - Vital 2

There are two separate reset functions; Reset 1 and Reset 2. The function of these is dependent on the operating mode selected (see Selection of operating mode). Reset 1 and Reset 2 can be configured for manual or automatic reset independently of each other by means of the input's Auto reset 1 and Auto reset 2.

### Manual monitored reset

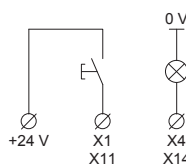

For manual resetting, a push button must be connected between X1 (Reset 1) or X11 (Reset 2) and +24 V. The monitoring contactors for external devices are to be connected in series with the push button. For manual reset, X4 (for Reset 1) and X14 (for Reset 2) serve as output for resetting the indicator lamps.

### Automatic reset

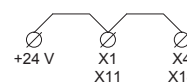

For automatic reset, X1 and X4 (Auto reset 1) or X11 and X14 (Auto reset 2) must be connected to +24 V. Monitoring contactors for external devices must be connected between +24 V and X1 (Auto reset 1) or X11 (Auto reset 2). If monitoring contactors are not used, X1 and X11 must be connected to +24 V.

## Time delay - Vital 2

Output group 2 can have disconnection delay by connecting inputs 0.5s and 1.0s being connected to +24 V. The system is binary, which means that the time values of the inputs are added together to give the total delay time.

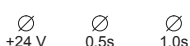

No delay

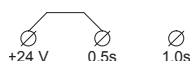

0.5 s delay

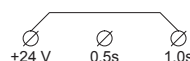

1.0 s delay

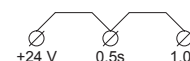

1.5 s delay



Technical data – Vital 2	
<b>Manufacturer</b>	ABB AB/Jokab Safety, Sweden
<b>Article number/ Ordering data</b> Vital 2	2TLA020070R4300
<b>Level of safety</b> EN ISO 13849-1 EN 62061 IEC/EN 61508-1...7 EN 954-1	PL e, category 4 SIL 3 SIL 3 Category 4
<b>PFH<sub>d</sub></b> Relay output Transistor output	2,00×10 <sup>-9</sup> 1,50×10 <sup>-9</sup>
<b>Colour</b>	Grey
<b>Weight</b>	390 g
<b>Power supply</b>	24 VDC ±15%
<b>Fuse</b> An external fuse must be connected in series with the supply voltage to A1	6 A
<b>Max line resistance</b> at nominal voltage to X1	150 Ohm
<b>Power consumption</b> Total current consumption	300 mA
<b>Input function 1 (dynamic safety circuit)</b> Dynamic output signal Dynamic input signal	T1 R1 (odd number of sensors in a circuit) R2 (even number of sensors in a circuit)
<b>Input function 2 (dynamic safety circuit)</b> Dynamic output signal Dynamic input signal	T11 R11 (odd number of sensors in a circuit) R12 (even number of sensors in a circuit)
<b>Reset input X1/X11</b> Voltage at X1/X11 when reset Reset current  Minimum contact closure time for reset	+24VDC 30 mA (300 mA peak during contact closure)  80 ms
<b>Number of sensors</b> Max. number of Eden or Tina units per input function Total max. cable length (depending on the number of Eden/Tina units) Max. number of light beams (Spot T/R) per input function Spot 10 Spot 35 Total max. cable length (depending on the number of Spot T/R)	10 500 m 1 3 100 m
Maximum number of units varies depending on the installation and cable size. For more information, see the examples in this chapter.	
<b>Response time</b> Relay output (Q1, Q11) Safe transistor outputs (Q2, Q12) Non-safe transistor output (Q2, Q12)	15 – 24 ms 11 – 20 ms 11 – 20 ms

<b>Relay outputs</b> Number of outputs Max. load capacity, res. load Max. load capacity, ind. load	2 NO 6A/250 VAC AC-1: 250 V/1,5 A AC-15: 250 V/1,5 A DC-1: 50 V/1,5 A DC-13: 24 V/1,5 A
<b>Safe transistor outputs</b> Number of outputs Output voltage (rated) Output voltage (at load)  Max. load	2 –24V > 22V at 800 mA/24V supply voltage 23,3V at 150 mA/24V supply voltage 800 mA
<b>Short circuit protection</b> Output – 0V Output – +24V	Yes Normal (not guaranteed)
<b>Non-safe transistor output (information)</b> Output voltage (rated) Max. load	+24 VDC 1 A
<b>Mounting</b> DIN rail	35 mm DIN rail
<b>Operating temperature range</b>	-10°C to + 55°C
<b>Connection blocks (detachable)</b> Max screw torque Max connection area: Solid conductors Conductor with socket contact Air and creep distance	1 Nm 1x4 mm <sup>2</sup> /2x1,5 mm <sup>2</sup> /12AWG 1x2,5 mm <sup>2</sup> /2x1 mm <sup>2</sup> 4kV/2 DIN VDE 0110
<b>Protection class</b> Enclosure Connection blocks	IP 40 IEC 60529 IP 20 IEC 60529
<b>Approved standards</b>	EN ISO 13849-1/ EN 954-1, EN ISO 13849-2, EN 62061, EN 61496-1, EN 574, EN 692, EN 60204-1, EN 50178, EN 61000-6-2, EN 61000-6-4, EN 61000-4- IEC/EN 61508-1...7

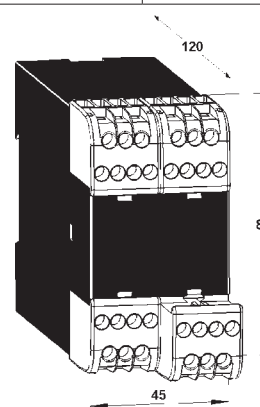

Connector blocks are detachable  
(without cables having to be disconnected)

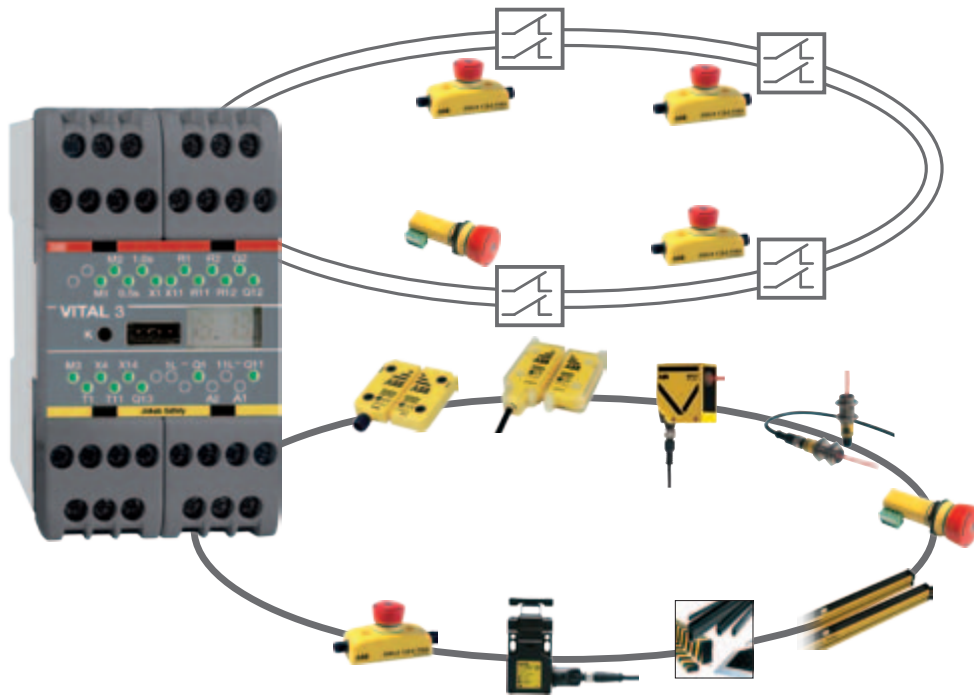

Vital 3 is a safety controller that combines functionality with the quick and easy installation of safety sensors. With two safe input functions and two different output groups, Vital 3 offers the capability to exclusively control smaller machine safety systems that would otherwise have required a programmable controller or multiple safety relays. How the two output groups are controlled by the input functions depends on which of the three operating modes is selected (see Selection of operating mode).

**Input function 1:**

A two-channel safety circuit designed for opening contacts, e.g. two-channel emergency stop or ABB Jokab Safety's safety switch JSNY5. One channel is fed with the dynamic signal and the other with static +24 VDC.

**Input function 2:**

A dynamic safety circuit where ABB Jokab Safety's safety sensors Eden, Tina and Spot can easily be connected in series. Up to 12 Eden or Tina devices can be connected in series per input function.

**Output group 1:**

A safe relay output in a duplicated series and a safe transistor output with output voltage of -24 VDC.

**Output group 2:**

A safe relay output in a duplicated series and a safe transistor output with output voltage of -24 VDC. In addition, output group 2 contains a non-safe transistor output with output voltage of +24 VDC, intended for information. The output group can have time delay from 0 to 1.5 s.

**Selection of operating modes**

Vital 3 can be configured to operate in one of three operating modes M1, M2 or M3. The selection of operating modes is done by connecting one of the terminals M1, M2 or M3 to +24 V.

## Operating mode M1 - Separate function Vital 3

Input function 1 controls output group 1, and input function 2 controls output group 2.

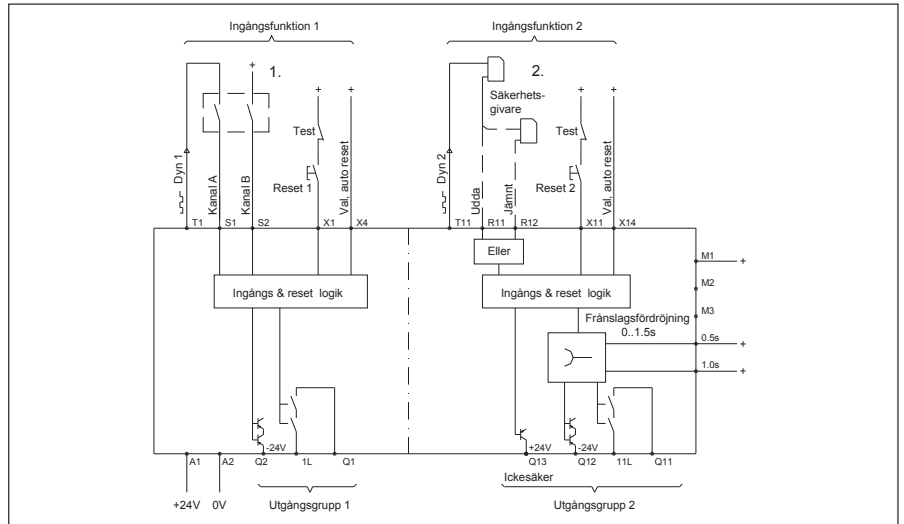

## Operating mode M2 - Input 1, master function Vital 3

Input function 1 stops all outputs, and input function 2 stops output group 2.

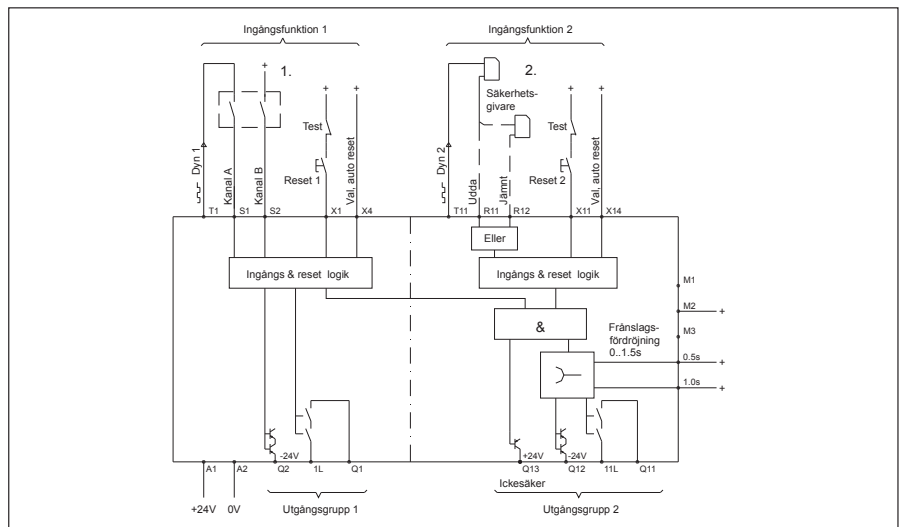

## Operating mode M3 - Parallel function Vital 3

Input function 1 and input function 2 operate in parallel and control all outputs. Reset/Auto reset 1 resets both input functions (Reset/Auto Reset 2 is not used).

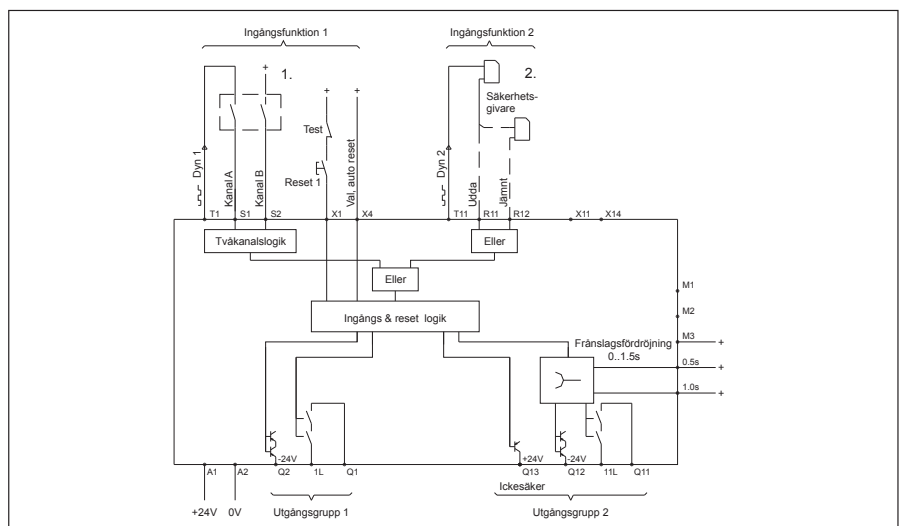

## Connection of protection/sensors - Vital 3

Depending on the input function and the number of sensors connected to the safety loop (odd or even number), the dynamic signal is connected between different terminals;

### Input function 1:

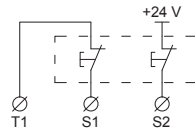

One of the two opening contacts is connected between T1 and S1 (dynamic signal). The second opening contact is connected between +24 V and S2 (static signal).

### Input function 2:

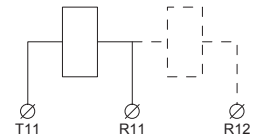

A dynamic signal is transmitted from T11, and depending on the number of sensors in the safety loop, the signal connects back to R11 (odd number of sensors) or R12 (even number of sensors).

## Connection of outputs - Vital 3

### Connection of safe transistor output (-24 V)

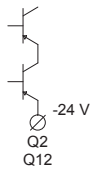

The safe transistor outputs Q2 (output group 1) and Q12 (output group 2) have an output voltage of -24 V.

### Connection of safe relay output

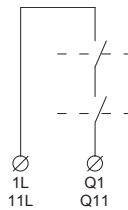

The safe relay outputs that are duplicated in series break between 1L-Q1 (output group 1) and 11L-Q11 (output group 2). The loads that break should be fitted with spark arresters to protect the outputs. The correct selection of VDR-circuit, RC circuit or diode is appropriate. Note that the diode extends the disconnection time of the load.

### Connection of information output

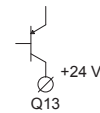

The non-safe transistor output Q13 is high (+24 V) when the outputs from output group 2 are active. The function is therefore dependent on the operating mode selected (see Selection of operating mode).

## Connection of reset - Vital 3

There are two separate reset functions; Reset 1 and Reset 2. The function of these is dependent on the operating mode selected (see Selection of operating mode). Reset 1 and Reset 2 can be configured for manual or automatic reset independently of each other by means of the input's Auto reset 1 and Auto reset 2.

### Manual monitored reset

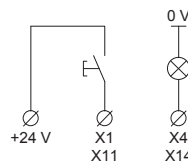

For manual resetting, a push button must be connected between X1 (Reset 1) or X11 (Reset 2) and +24 V. The monitoring contactors for external devices are to be connected in series with the push button. For manual reset, X4 (for Reset 1) and X14 (for Reset 2) serve as output for resetting the indicator lamps.

### Automatic reset

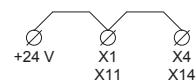

For automatic reset, X1 and X4 (Auto reset 1) or X11 and X14 (Auto reset 2) must be connected to +24 V. Monitoring contactors for external devices must be connected between +24 V and X1 (Auto reset 1) or X11 (Auto reset 2). If monitoring contactors are not used, X1 and X11 must be connected to +24 V.

## Time delay - Vital 3

Output group 2 can have disconnection delay by connecting inputs 0.5s and 1.0s being connected to +24 V. The system is binary, which means that the time values of the inputs are added together to give the total delay time.



No delay

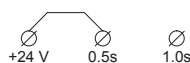

0.5 s delay



1.0 s delay

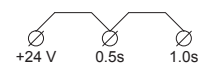

1.5 s delay

Technical data – Vital 3	
<b>Manufacturer</b>	ABB AB/Jokab Safety, Sweden
<b>Article number/ Ordering data</b> Vital 3	2TLA020070R4400
<b>Level of safety</b> EN ISO 13849-1 EN 62061 IEC/EN 61508-1...7 EN 954-1	PL e, category 4 SIL 3 SIL 3 Category 4
<b>PFH<sub>d</sub></b> Relay output Transistor output	2,00×10 <sup>-9</sup> 1,50×10 <sup>-9</sup>
<b>Colour</b>	Grey
<b>Weight</b>	390 g
<b>Power supply</b>	24 VDC ±15%
<b>Fuse</b> An external fuse must be connected in series with the supply voltage to A1	6 A
<b>Max line resistance</b> at nominal voltage to X1	150 Ohm
<b>Power consumption</b> Total current consumption	300 mA
<b>Input function 1 (two channel, normally closed circuit)</b> Dynamic output signal Dynamic input signal Static input signal (+24 V)	T1 S1 S2
<b>Input function 2 (dynamic safety circuit)</b> Dynamic output signal Dynamic input signal	T11 R11 (odd number of sensors in a circuit) R12 (even number of sensors in a circuit)
<b>Reset input X1/X11</b> Voltage at X1/X11 when reset Reset current  Minimum contact closure time for reset	+24VDC 30 mA (300 mA peak during contact closure)  80 ms
<b>Number of sensors</b> Max. number of Eden or Tina units per input function 2 Total max. cable length (depending on the number of Eden/Tina units) Max. number of light beams (Spot T/R) per input function 2 Spot 10 Spot 35 Total max. cable length (depending on the number of Spot T/R)	10 500 m 1 3 100 m
Maximum number of units varies depending on the installation and cable size. For more information, see the examples in this chapter.	
<b>Response time</b> Relay output (Q1, Q11) Safe transistor outputs (Q2, Q12) Non-safe transistor output (Q2, Q12)	15 – 24 ms 11 – 20 ms 11 – 20 ms

<b>Relay outputs</b> Number of outputs Max. load capacity, res. load Max. load capacity, ind. load	2 NO 6A/250 VAC AC-1: 250 V/1,5 A AC-15: 250 V/1,5 A DC-1: 50 V/1,5 A DC-13: 24 V/1,5 A
<b>Safe transistor outputs</b> Number of outputs Output voltage (rated) Output voltage (at load)  Max. load	2 –24V > 22V at 800 mA/24V supply voltage 23,3V at 150 mA/24V supply voltage 800 mA
<b>Short circuit protection</b> Output – 0V Output – +24V	Yes Normal (not guaranteed)
<b>Non-safe transistor output (information)</b> Output voltage (rated) Max. load	+24 VDC 1 A
<b>Mounting</b> DIN rail	35 mm DIN rail
<b>Operating temperature range</b>	-10°C to + 55°C
<b>Connection blocks (detachable)</b> Max screw torque Max connection area: Solid conductors Conductor with socket contact Air and creep distance	1 Nm 1x4 mm <sup>2</sup> /2x1,5 mm <sup>2</sup> /12AWG 1x2,5 mm <sup>2</sup> /2x1 mm <sup>2</sup> 4kV/2 DIN VDE 0110
<b>Protection class</b> Enclosure Connection blocks	IP 40 IEC 60529 IP 20 IEC 60529
<b>Approved standards</b>	EN ISO 13849-1/EN 954-1, EN ISO 13849-2, EN 62061, EN 61496-1, EN 574, EN 692, EN 60204-1, EN 50178, EN 61000-6-2, EN 61000-6-4, EN 61000-4-, IEC/EN 61508-1...7

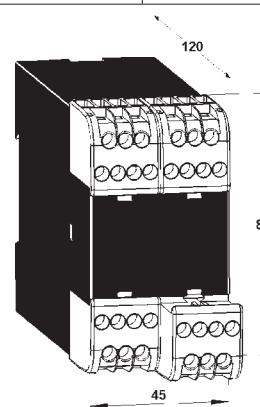

Connector blocks are detachable  
(without cables having to be disconnected)

# Why should you use the Tina adapter units?

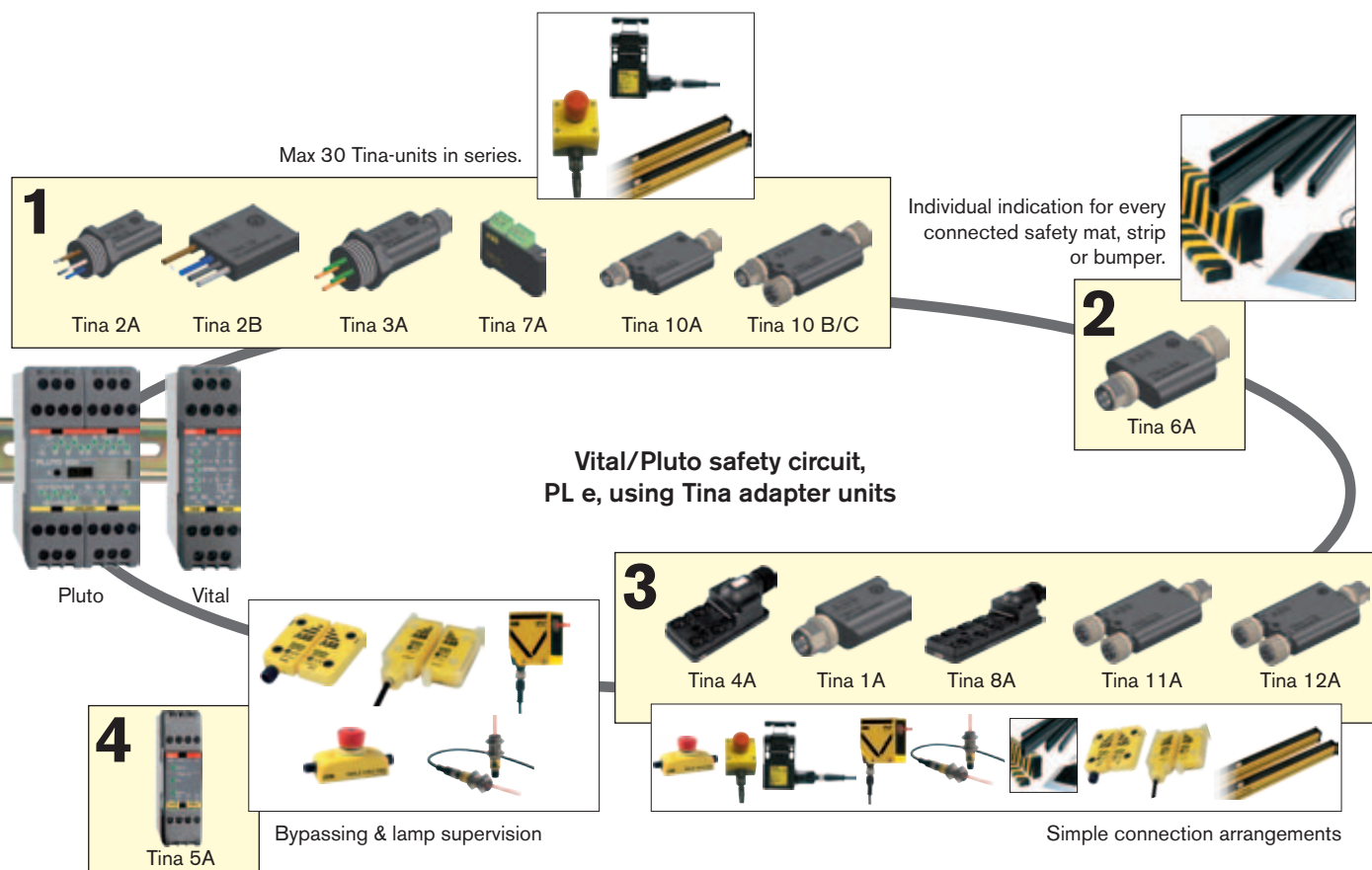

## - to adapt safety sensors to the dynamic single channel circuit according to PL e!

The Tina devices adapt safety sensors with mechanical contacts, such as emergency stops, switches and light grids/curtains with dual outputs to the dynamic safety circuit in Vital and Pluto to safety sensors with mechanical contacts, such as emergency stops, switches and light grids/curtains with dual outputs. This means Pluto complies with EN ISO 13849-1 and SIL 3 in EN 62061 and EN 61508 for the connected safety sensors with the Vital/Pluto controller. Note that ABB Jokab Safety's dynamic safety sensors, such as Eden and Spot can be connected directly to the Vital/Pluto circuit without intermediate Tina devices.

## - For bypassing of safety sensor in a dynamic circuit!

The Tina 5A bypass unit is used for bypassing of safety sensor in a dynamic circuit and provides the possibility for supervision of bypass lamp indication. During bypassing of safety devices e.g. a light grid or an interlocked gate switch/

sensor, it must only be possible to allow the bypass function if a lamp indication is given. The lamp indication must therefore be supervised. With this system it is possible to bypass one or more safety sensor at the same time.

## - As a connection block for simplified connection to a dynamic circuit!

The Tina 4A/8A connection blocks are available with 4 or 8 M12 connections. They are used to enable several safety sensor having M12 connection terminated cables to be connected together. The blocks are connected with a suitable multi-core cable, that contains status information from each safety component, to the control cabinet. This enables simplified wiring. The connection block contains electronic circuits which modify the coded dynamic signal in the safety circuit. Note Several connection blocks can be connected to one Vital/Pluto. Using Tina 4A/8A connection blocks eliminates connection faults and can significantly reduce system cable costs.



# Tina is available in several versions

Tina is available in several versions depending on the type of safety component that is connected to the Vital or Pluto circuit. Also available is a bypassing unit, three connector blocks with 2, 4 or 8 M12 connectors, and a blind plug for un-used connections. As an accessory there is a Y-connector for series or parallel connection and even for connection of light beams with separate transmitter and receiver. Tina units are also included in emergency stop models Smile Tina and Tina Inca. This is to adapt ABB Jokab Safety's products to dynamic safety circuits.

All Tina-units are designed to decode the dynamic signal in the safety circuit of Vital/Pluto.

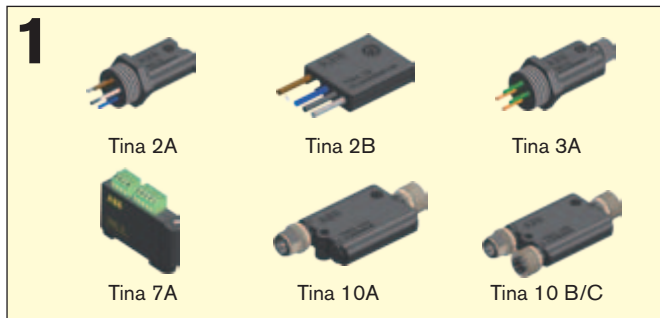

**Tina 2A/B, Tina 3A and Tina 7A** are used to connect safety components with mechanical contacts, such as emergency stops, switches and light curtains/light beams with relay outputs. NOTE! In order to maintain safety category 4 and to reduce the risk of electrical interference, Tina 2 A, 3A and 7A units must be installed within the same physical encapsulation as the safety component that is to be monitored, and this is to be connected to the Tina unit with as short a cable as possible.

**Tina 10A/B/C** units are used for connection of Focus light beams/curtains to Vital or Pluto. Tina 10B has an extra M12 connector that enables reset, a reset lamp and switching of the Focus supply voltage. The Tina 10C has an additional M12 connector that permits a Focus transmitter to receive power.



**Tina 6A** is used to connect door sensitive edges and safety mats, and provides an indication for each unit (Tina 7A may also be used). If a Tina 6A is connected close to the edge or mat, the risk of electrical interference is reduced.

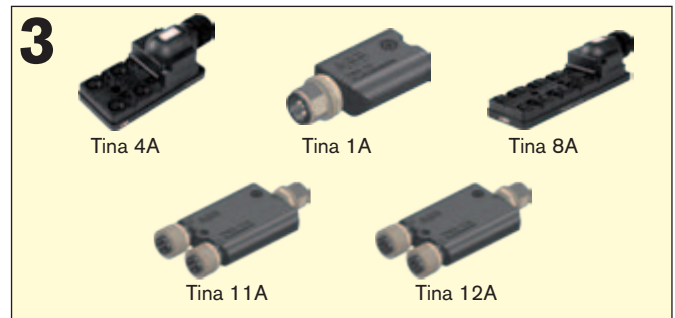

**Tina 4A, Tina 8A, Tina 11A and Tina 12A** are used as terminal blocks and simplify connection to a Vital safety circuit. Each safety component is connected to the terminal block via an M12 connection. A terminal block is connected to the apparatus enclosure by means of a cable that also contains status information from each safety component that is connected to Tina 4A/Tina 8A and summed information from Tina 11A/Tina 12A. Tina 1A must be used as a blanking plug in unused M12 connections.



**Tina 5A** is used to bypass the safety sensors in Vital security loop and for monitoring the indicator light switch off. Tina 5A bypass units are used for bypassing of safety sensors in a dynamic circuit and provides the possibility for supervision of bypass lamp indication.

## - why should I choose Tina?

- Safety circuit, PL e, EN ISO 13849-1
- Individual status indication of every connected unit in the safety circuit
- Supervision of lamp indicating bypassing of safety device
- Quick release M12 connector

# Blanking plug for connection block

# Tina 1A



Tina 1A is a device that is designed for use with the connection blocks Tina 4A or Tina 8A where it is used as a blind plug in unused M12 connections. The device is fitted with a LED for status indication of the dynamic safety circuit.

## Approvals:



## Application:

Is used as a blanking plug in unused M12 connectors at connection blocks

## Features:

Indication of status by LED

Technical data – Tina 1A	
<b>Manufacturer</b> Article number/Ordering data	ABB AB/Jokab Safety, Sweden 2TLA020054R0000 Tina 1A
<b>Level of safety</b> IEC/EN 61508-1...7 EN 62061 EN ISO 13849-1 EN 954-1	SIL3 SIL3 PL e, category 4 Category 4
<b>PFH<sub>d</sub></b>	4,50 × 10 <sup>-9</sup>
<b>Power supply</b> Operating voltage Total current consumption  Time delay t (in/out) Voltage supply at normal operation (protection OK) and 24 VDC supply voltage	24 VDC + +15%, -25% 17 mA (27 mA with max information output) Information output: Max 10 mA t < 60 μs Dynamic input: between 9 and 13 volt (RMS) Dynamic output: between 9 and 13 volt (RMS) Information output: ~ 23 VDC
<b>General</b> Protection class Ambient temperature Humidity range Housing material Connector Size Weight Colour	IP67 Storage: -30...+70°C Operation: -10...+55°C 35 to 85 % (with no icing or condensation) Based on polyamide, Macromelt OM646 (V0) M12 5-pole male 48 × 23 × 15 mm (L x W x H) ~20 g Black

<b>Approved standards</b>	European Machinery Directive 2006/42/EC EN ISO 12100-1:2003, EN ISO 12100-2:2003, EN 60204-1:2007, EN 954-1:1996, EN ISO 13849-1:2008, EN 62061:2005
<b>Certificates</b>	TÜV Nord

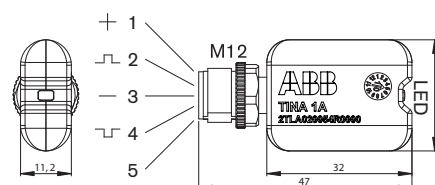

### 5-pin M12 male contact:

1. +24 VDC
2. Dynamic input signal
3. 0 VDC
4. Dynamic output signal
5. Not used

# Adaptation unit

# Tina 2A/B

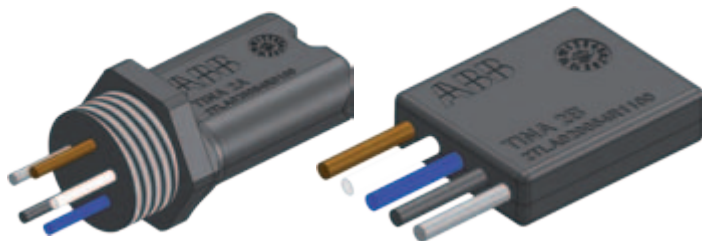

Tina 2A/B is a device that adapts the safety sensors with mechanical contacts, such as emergency stops, switches and light curtains/light grids with their own relay outputs to the dynamic safety circuit.

Tina 2A is fitted with M20 contact which simplifies connection to safety sensors prepared for M20 connection. Tina 2B is very small and can often be placed in the safety components' enclosure. Both Tina 2A and Tina 2B are fitted with LEDs for status indication of the dynamic safety circuit.

## Approvals:



## Application:

Adaptation of safety sensors with mechanical contacts to the dynamic safety circuit.

Example:

Emergency stops

Switches

Light beams / light curtains with relay outputs

## Features:

Simplifies the system as well as maintaining the safety level

Indication of status by LED

Technical data – Tina 2A	
<b>Manufacturer</b> Article number/Ordering data	ABB AB/Jokab Safety, Sweden 2TLA020054R0100 Tina 2A 2TLA020054R1100 Tina 2B
<b>Level of safety</b> IEC/EN 61508-1...7 EN 62061 EN ISO 13849-1 EN 954-1	SIL3 SIL3 PL e, category 4 Category 4
<b>PFH<sub>d</sub></b>	4,50 × 10 <sup>-9</sup>
<b>Power supply</b> Operating voltage Total current consumption  Time delay t (in/out) Voltage supply at normal operation (protection OK) and 24 VDC supply voltage	24 VDC + 15 %, -25 % 17 mA (27 mA with max information output) Information output: Max 10 mA t < 60 μs Dynamic input: between 9 and 13 volt (RMS) Dynamic output: between 9 and 13 volt (RMS) Information output: ~ 23 VDC
<b>General</b> Protection class Ambient temperature  Humidity range  Housing material Connector Size	IP67 Storage: -30...+70°C Operation: -10...+55°C 35 to 85 % (with no icing or condensation) Based on polyamide, Macromelt OM646 (V0) 5x0.34 mm <sup>2</sup> wires, 0.15 m Tina 2A: 43 × 24 × 24 mm Tina 2B: 28 × 21 × 7 mm (L x W x H)

<b>Weight</b>	Tina 2A: ~30 g Tina 2B: ~20 g
<b>Colour</b>	Black
<b>Approved standards</b>	European Machinery Directive 2006/42/EC EN ISO 12100-1:2003, EN ISO 12100-2:2003, EN 60204-1:2007, EN 954-1:1996, EN ISO 13849-1:2008, EN 62061:2005
<b>Certificates</b>	TÜV Nord

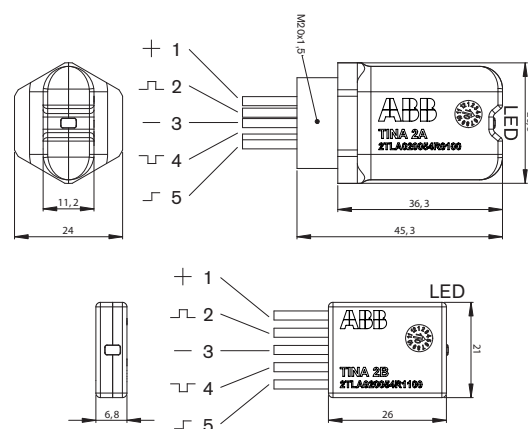

### Cable connection:

1. Brown: +24 VDC
2. White: Dynamic input signal
3. Blue: 0 VDC
4. Black: Dynamic output signal
5. Grey: Information

# Adaptation unit

# Tina 3A/Aps

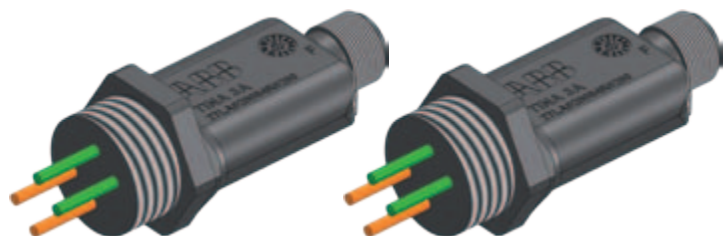

Tina 3A/Aps is a device that adapts the safety sensors with mechanical contacts, such as emergency stops, switches and light curtains/light grids with their own relay outputs to the dynamic safety loop.

Both Tina 3A and Tina 3Aps are fitted with M20 contacts which simplifies connection to safety sensors prepared for M20 connection. The devices are then easily connected to the dynamic safety loop through a 5-pin M12 contact to the Tina device. Tina 3Aps has an extra conductor for the supply voltage to the safety sensor.

## Approvals:



## Application:

Adaptation of safety sensors with mechanical contacts to the dynamic safety circuit.

Example:

Emergency stops

Switches

Light beams / light curtains with relay outputs

## Features:

Simplifies the system as well as maintaining the safety level

Indication of status by LED

Technical data – Tina 3A	
<b>Manufacturer</b> Article number/Ordering data	ABB AB/Jokab Safety, Sweden 2TLA020054R0200 Tina 3A 2TLA020054R1400 Tina 3Aps
<b>Level of safety</b> IEC/EN 61508-1...7 EN 62061 EN ISO 13849-1 EN 954-1	SIL3 SIL3 PL e, category 4 Category 4
<b>PFH<sub>d</sub></b>	4,50 × 10 <sup>-9</sup>
<b>Power supply</b> Operating voltage Total current consumption  Time delay t (in/out) Current through safety device contacts Short circuit current between contacts Voltage supply at normal operation (protection OK) and 24 VDC supply voltage	24 VDC + +15%, -25% 47 mA (57 mA with max information output) Information output: Max 10 mA t < 70 μs  12 mA  10 mA Dynamic input: between 9 and 13 volt (RMS) Dynamic output: between 9 and 13 volt (RMS) Information output: ~ 23 VDC
<b>General</b> Protection class Ambient temperature  Humidity range  Housing material	IP67 Storage: -30...+70°C Operation: -10...+55°C 35 to 85 % (with no icing or condensation) Based on polyamide, Macromelt OM646 (V0)

<b>Connectors</b>	M12 5-pole connector Green loop wires (A1 & A2) Orange loop wires (B1 & B2) Brown (+24 VDC), Blue (0 VDC) wires (Tina 3Aps only)
<b>Size</b> <b>Weight</b> <b>Colour</b>	54 × 24 × 24 mm (L x W x H) ~30 g Black
<b>Approved standards</b>	European Machinery Directive 2006/42/EC EN ISO 12100-1:2003, EN ISO 12100-2:2003, EN 60204-1:2007, EN 954-1:1996, EN ISO 13849-1:2008, EN 62061:2005
<b>Certificates</b>	TÜV Nord

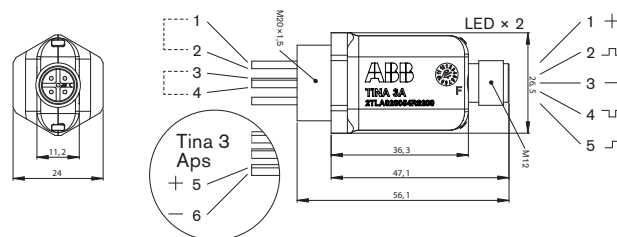

### Cable connection:

1. Safety circuit A1-A2
2. Safety circuit A1-A2
3. Safety circuit B1-B2
4. Safety circuit B1-B2
5. Brown: +24 VDC (only Tina 3 Aps)
6. Blue: 0 VDC (only Tina 3Aps)

### 5-pin M12 male contact:

1. +24 VDC
2. Dynamic input signal
3. 0 VDC
4. Dynamic output signal
5. Not used

# Connection block

# Tina 4A



Tina 4A is a connection block with four 5-pin M12 connections. It is used to connect multiple safety sensors with M12 contacts via a single cable to a controller or PLC. This simplifies cable running and reduces cable costs. Multiple connection blocks can be connected to a Vital/Pluto. Tina 1A is used for unused M12 connections.

## Approvals:



## Application:

Connection block for up to four safety sensors adapted to the dynamic safety circuit.

## Features:

Simplifies cable routing and reduces cable costs.

Allows branching of up to four safety sensors to the dynamic safety circuit.

Technical data – Tina 4A	
<b>Manufacturer</b> Article number/Ordering data	ABB AB/Jokab Safety, Sweden 2TLA020054R0300 Tina 4A
<b>Level of safety</b> IEC/EN 61508-1...7 EN 62061 EN ISO 13849-1 EN 954-1	SIL3 SIL3 PL e, category 4 Category 4
<b>PFH<sub>d</sub></b>	4,50 × 10 <sup>-9</sup>
<b>Power supply</b> Operating voltage Total current consumption  Time delay t (in/out) Voltage supply at normal operation (protection OK) and 24 VDC supply voltage	24 VDC + +15%, -15% 10 mA (20 mA with max information summary output) Information output: Max 10 mA t < 60 μs Dynamic input: between 9 and 13 volt (RMS) Dynamic output: between 9 and 13 volt (RMS) Information output: ~ 23 VDC
<b>General</b> Protection class Ambient temperature Humidity range Housing material Connectors Size Weight Colour	IP67 Storage: -30...+70°C Operation: -10...+55°C 35 to 85 % (with no icing or condensation) Based on polyamide, Macromelt OM646 (V0) M12 5-pole female (4x) 9-pin connection block 99 × 50 × 43 mm (L x W x H) ~100 g Black

<b>Approved standards</b>	European Machinery Directive 2006/42/EC EN ISO 12100-1:2003, EN ISO 12100-2:2003, EN 60204-1:2007, EN 954-1:1996, EN ISO 13849-1:2008, EN 62061:2005
<b>Certificates</b>	TÜV Nord

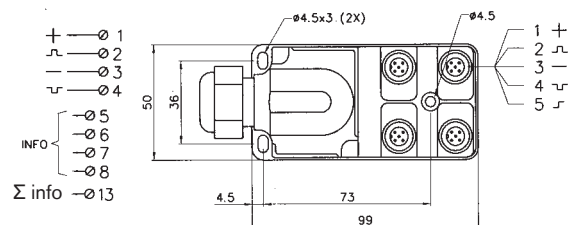

### Connection block:

1. +24 VDC
2. Dynamic input signal
3. 0 VDC
4. Dynamic output signal
5. Information (contact #1)
6. Information (contact #2)
7. Information (contact #3)
8. Information (contact #4)
13. Summarized information (contact #1-4)

### 5-pin M12 female contact (x4):

1. +24 VDC
2. Dynamic input signal
3. 0 VDC
4. Dynamic output signal
5. Information

## Adaptation unit

# Tina 5A

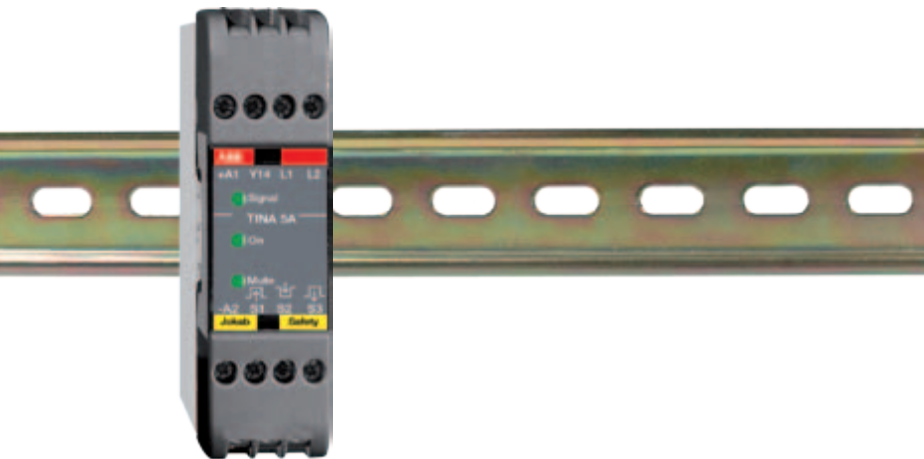

### Approvals:



### Application:

Bypassing of safety device-  
sconnected to the dynamic  
safety circuit and for supervi-  
sion of lamp indication.

### Features:

One or more safety devices  
can be bypassed  
supervised lamp indication  
Indication of status by LEDs

### Function

The Tina 5A is designed for bypassing of safety devices connected to the Vital/Pluto safety circuit and for supervision of lamp indication.

During bypassing of safety devices e.g. a light grid or an interlocked gate, it must only be possible to allow the bypass function if a lamp indication is on. The lamp indication must therefore be supervised. Whether indication is required depends on the specific situation and result of risk analysis.

When the Tina 5A receives a coded dynamic signal to S1 and the bypass indication lamp is on (connected across L1-L2), a bypassing output signal is provided on S2 and S3. A broken or short circuit in the indication lamp leads to an interruption of the bypass output signal on S2 and S3, therefore stopping the bypassing.

The dynamic signal to S1 on Tina 5A must be the input signal from the first of the safety devices intended to bypass. The signal can be connected via output contacts from a safety relay, a safety timer or be initiated via a unit providing the dynamic coded signal as for example an Eden sensor or a Spot light beam. The dynamic output from S2 or S3 is connected to the output of the safeguards to be bypassed

### S2 is used if:

- an **odd** number of dynamic safety units is to be bypassed using an **odd** number of dynamic safety units, i.e. the sum of Tina + Eden and Spot units (incl. Tina 5A). See drawing HE3824C
- an **even** number of dynamic safety units is to be bypassed using an **even** number of dynamic safety units, i.e. the sum of Tina + Eden and Spot units (incl. Tina 5A). See drawing HE3824F

### S3 is used if:

- an **odd** number of dynamic safety units is to be bypassed using an **even** number of dynamic safety units, i.e. the sum of Tina + Eden and Spot units (incl. Tina 5A). See drawing HE3824D
- an **even** number of dynamic safety units is to be bypassed using an **odd** number of dynamic safety units, i.e. the sum of Tina + Eden and Spot units (incl. Tina 5A). See drawing HE3824E

The total number of dynamic safety units is calculated by adding the number of Eden, Spot and Tina units connected in the Vital circuit. See the connection examples HE3824C, D, E, F or G.



### Bypassing of Eden and Tina units.

If one or more Eden or Tina units are bypassed by a Tina 5A, a diode, such as a 1N4007 must be inserted with forward current out from pin 4 of the last bypassed unit. If one or more Eden or Tina units are bypassed by one or more Eden or Tina units direct to each other, a diode, such as a 1N4007 must be inserted by the last unit in both loops with forward current out from pin 4. Refer to example HD3801A. In the case of bypassing of a Tina 10A, B or C or of more than one unit towards each other, it is recommended that a Tina 5A or M12-3M is used. See the examples HE3824C, D, E, F or G.

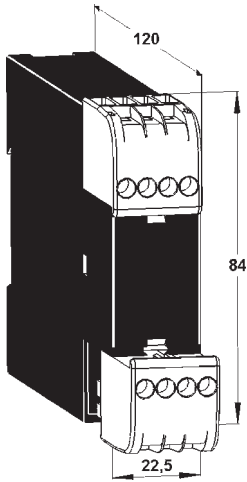

#### Connections:

- +A1:** +24 VDC
- Y14:** Information of bypass
- L1-L2:** Bypass lamp (or 820 ohm/2W resistor)
- A2:** 0 VDC
- S1:** Dynamic signal in
- S2:** Dynamic signal out, transcoded
- S3:** Dynamic signal out, transcoded twice

### Technical data – Tina 5A

<b>Manufacturer</b> Article number/Ordering data	ABB AB/Jokab Safety, Sweden 2TLA020054R0400 Tina 5A
<b>Level of safety</b> IEC/EN 61508-1...7 EN 62061 EN ISO 13849-1 EN 954-1	SIL3 SIL3 PL e, category 4 Category 4
<b>PFH<sub>d</sub></b>	4,50×10 <sup>-9</sup>
<b>Power supply</b> Operating voltage Current consumption, A1-A2  Bypass connection  Time delay t (in/out) Voltage supply at normal operation (protection OK) and 24 VDC supply voltage	24 VDC + +10%, -10% No bypass: 10 mA Bypass using a 5 W indication lamp: 240 mA Tina 5A can bypass max. 30 Eden/Tina-units or 6 Spot T/R t < 260 μs Dynamic input: between 9 and 13 volt (RMS) Dynamic output: between 9 and 13 volt (RMS) Information output: ~ 23 VDC
<b>General</b> Protection class  Ambient temperature Humidity range  Housing material  Connectors  Mounting Size Weight Colour	Enclosure: IP40 Connection block: IP20 -10...+55°C 35 to 85 % (with no icing or condensation) Based on polyamide, Macromelt OM646 (V0) Connection blocks with a total of 8 terminals (2 x 4) 35 mm DIN rail 120 × 84 × 22,5 mm (L x W x H) ~135 g Grey
<b>Approved standards</b>	European Machinery Directive 2006/42/EC EN ISO 12100-1:2003, EN ISO 12100-2:2003, EN 60204-1:2007, EN 954-1:1996, EN ISO 13849-1:2008, EN 62061:2005, EN 61496-1:2004 + A1:2008
<b>Certificates</b>	TÜV Nord

# Adaptation unit

# Tina 6A



Tina 6A monitors short circuits. It is used to adapt the safety sensors with safety contact strips and safety mats with relay outputs to the dynamic safety circuit. The device is fitted with a LED for status indication of the dynamic safety circuit.

## Approvals:



## Application:

Short circuit monitoring and adaptation of safety sensors to the dynamic safety circuit

For example:  
Contact rails  
Bumpers  
Safety mats

## Features:

Simplifies the system as well as maintaining the safety level

Indication of status by LED

Technical data – Tina 6A	
<b>Manufacturer</b> Article number/Ordering data	ABB AB/Jokab Safety, Sweden 2TLA020054R0600 Tina 6A
<b>Level of safety</b> IEC/EN 61508-1...7 EN 62061 EN ISO 13849-1 EN 954-1	SIL3 SIL3 PL e, category 4 Category 4
<b>PFH<sub>d</sub></b>	$4,50 \times 10^{-9}$
<b>Power supply</b> Operating voltage Total current consumption  Current through safety device contacts Short circuit current between contacts Time delay t (in/out) Voltage supply at normal operation (protection OK) and 24 VDC supply voltage	24 VDC + +15%, -25% 47 mA (57 mA with max information output) Information output: Max 10 mA  12 mA 10 mA t < 70 μs Dynamic input: between 9 and 13 volt (RMS) Dynamic output: between 9 and 13 volt (RMS) Information output: ~ 23 VDC
<b>General</b> Protection class Ambient temperature  Humidity range  Housing material  Connectors	IP67 Storage: -30...+70°C Operation: -10...+55°C 35 to 85 % (with no icing or condensation) Based on polyamide, Macromelt OM646 (V0) M12 5-pole male M12 5-pole female

Size	63 × 31 × 15 (L × W × H)
Weight	~30 g
Colour	Black
<b>Approved standards</b>	European Machinery Directive 2006/42/EC EN ISO 12100-1:2003, EN ISO 12100-2:2003, EN 60204-1:2007, EN 954-1:1996, EN ISO 13849-1:2008, EN 62061:2005
<b>Certificates</b>	TÜV Nord

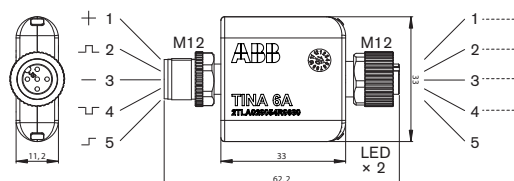

### 5-pin M12 male contact:

1. +24 VDC
2. Dynamic input signal
3. 0 VDC
4. Dynamic output signal
5. Information

### 5-pin M12 female contact:

1. Safety circuit A1-A2
2. Safety circuit A1-A2
3. Safety circuit B1-B2
4. Safety circuit B1-B2
5. Not used

# Adaptation unit

# Tina 7A



Tina 7A is a device that adapts the safety sensors with mechanical contacts, such as emergency stops, switches and light curtains/light grids with their own relay outputs to the dynamic safety circuit.

The device is designed for installation in an equipment cabinet where it can be mounted directly on a 35 mm DIN busbar, and the conductors are then connected directly to the screw terminals.

## Approvals:



## Application:

Adaptation of safety sensors with mechanical contacts to the dynamic safety circuit.

Example:

Emergency stops

Switches

Light beams / light curtains with relay outputs

## Features:

Simplifies the system as well as maintaining the safety level

Indication of status by LED

Adapted for easy installation on 35 mm DIN rail in cabinets

Technical data – Tina 7A	
<b>Manufacturer</b> Article number/Ordering data	ABB AB/Jokab Safety, Sweden 2TLA020054R0700 Tina 7A
<b>Level of safety</b> IEC/EN 61508-1...7 EN 62061 EN ISO 13849-1 EN 954-1	SIL3 SIL3 PL e, category 4 Category 4
<b>PFH<sub>d</sub></b>	4,50×10 <sup>-9</sup>
<b>Power supply</b> Operating voltage Total current consumption  Current through safety device contacts Short circuit current between contacts Time delay t (in/out) Voltage supply at normal operation (protection OK) and 24 VDC supply voltage	24 VDC + +15%, -25% 47 mA (57 mA with max information output) Information output: Max 10 mA  12 mA  10 mA t < 70 μs Dynamic input: between 9 and 13 volt (RMS) Dynamic output: between 9 and 13 volt (RMS) Information output: ~ 23 VDC
<b>General</b> Protection class Ambient temperature  Humidity range  Housing material	IP20 Storage: -30...+70°C Operation: -10...+55°C 35 to 85 % (with no icing or condensation) Based on polyamide, Macromelt OM646 (V0)

<b>Connectors</b>	5-pin connection block (power supply, dynamic in/out, info) 4-pin connection block (safety loop A1-A2, B1-B2)
<b>Mounting</b> Size Weight Colour <b>Approved standards</b>	DIN rail 61 × 46 × 14 (L × W × H) ~35 g Black European Machinery Directive 2006/42/EC EN ISO 12100-1:2003, EN ISO 12100-2:2003, EN 60204-1:2007, EN 954-1:1996, EN ISO 13849-1:2008, EN 62061:2005
<b>Certificates</b>	TÜV Nord

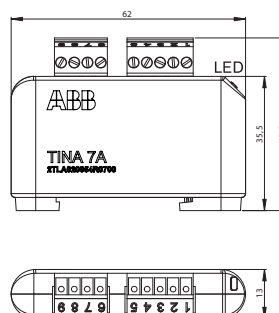

- 1 +
- 2 -
- 3 -
- 4 -
- 5 -
- 6 .....
- 7 .....
- 8 .....
- 9 .....

### Connection block:

1. +24 VDC
2. Dynamic input signal
3. 0 VDC
4. Dynamic output signal
5. Information
6. Safety circuit A1-A2
7. Safety circuit A1-A2
8. Safety circuit B1-B2
9. Safety circuit B1-B2

# Connection block

# Tina 8A



Tina 8A is a connection block with eight 5-pin M12 connections. It is used to connect multiple safety sensors with M12 contacts via a single cable to a controller or PLC. This simplifies cable running and reduces cable costs. Multiple connection blocks can be connected to a Vital/Pluto. Tina 1A is used for unused M12 connections.

## Approvals:



## Application:

Connection block for up to eight safety sensors adapted to the dynamic safety circuit.

## Features:

Simplifies cable routing and reduces cable costs.

Allows branching of up to four safety sensors to the dynamic safety circuit.

Technical data – Tina 8A	
<b>Manufacturer</b> Article number/Ordering data	ABB AB/Jokab Safety, Sweden 2TLA020054R0500 Tina 8A
<b>Level of safety</b> IEC/EN 61508-1...7 EN 62061 EN ISO 13849-1 EN 954-1	SIL3 SIL3 PL e, category 4 Category 4
<b>PFH<sub>d</sub></b>	4,50 × 10 <sup>-9</sup>
<b>Power supply</b> Operating voltage Total current consumption  Time delay t (in/out) Voltage supply at normal operation (protection OK) and 24 VDC supply voltage	24 VDC + +15%, -15% 15 mA (25 mA with max information summary output) Information output: Max 10 mA t < 60 μs Dynamic input: between 9 and 13 volt (RMS) Dynamic output: between 9 and 13 volt (RMS) Information output: ~ 23 VDC
<b>General</b> Protection class Ambient temperature Humidity range Housing material Connectors Size Weight Colour	IP67 Storage: -30...+70°C Operation: -10...+55°C 35 to 85 % (with no icing or condensation) Based on polyamide, Macromelt OM646 (V0) M12 5-pole female (8x) 13-pin connection block 149 × 50 × 43 (L × W × H) ~140 g Black

<b>Approved standards</b>	European Machinery Directive 2006/42/EC EN ISO 12100-1:2003, EN ISO 12100-2:2003, EN 60204-1:2007, EN 954-1:1996, EN ISO 13849-1:2008, EN 62061:2005
<b>Certificates</b>	TÜV Nord

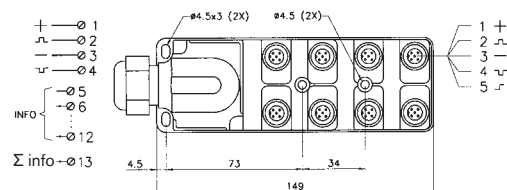

### Connection block:

1. +24 VDC
2. Dynamic input signal
3. 0 VDC
4. Dynamic output signal
5. Information (contact #1)
6. Information (contact #2)
7. Information (contact #3)
8. Information (contact #4)
9. Information (contact #5)
10. Information (contact #6)
11. Information (contact #7)
12. Information (contact #8)
13. Summarized information (contact #1-8)

### 5-pin M12 female contact (x8):

1. +24 VDC
2. Dynamic input signal
3. 0 VDC
4. Dynamic output signal
5. Information

## Connection examples of safety sensors to Tina 8A

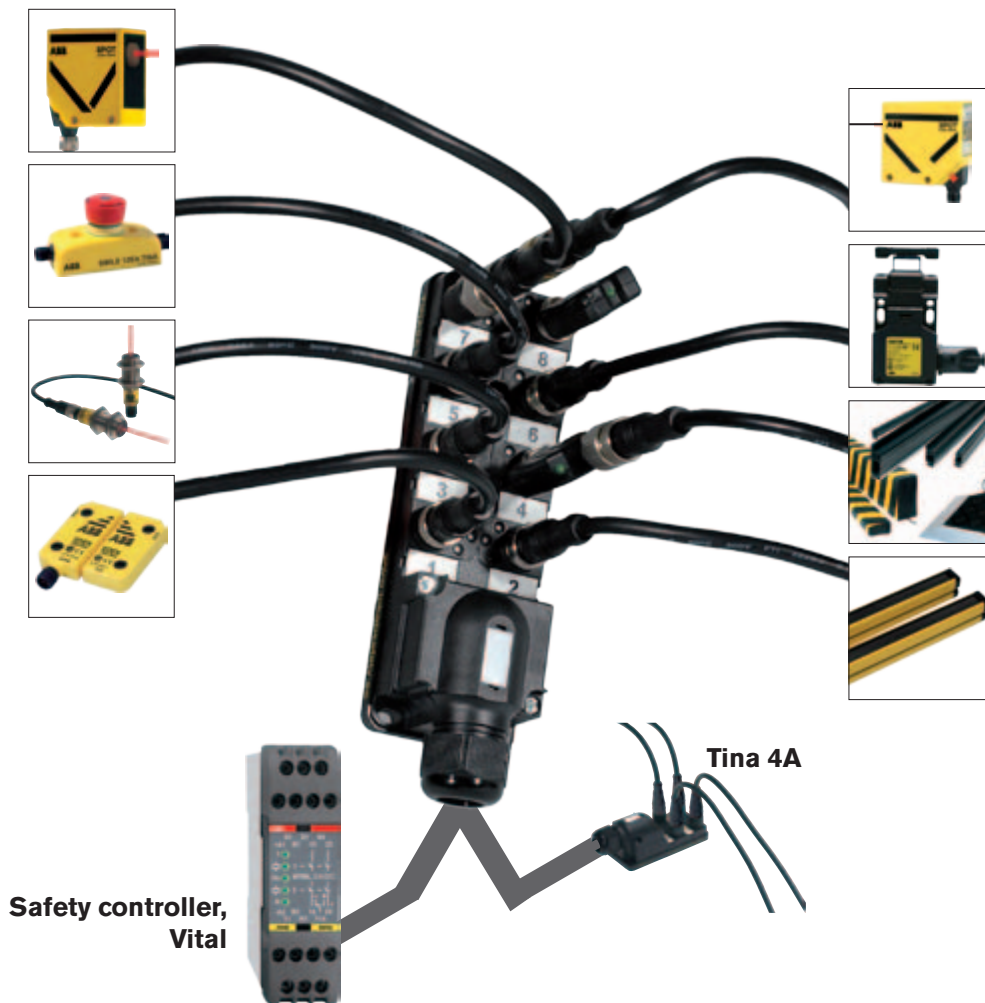

### Connection 1

One Eden is connected directly to the Tina 8A. The Eden status is shown by an LED on the Adam sensor. A status information signal is also connected to Tina 8A.

### Connection 2

One Focus safety light grid is connected to the Tina 8A via a Tina 10A. The output from the Tina 10A is via a M12 connector. The connection between Tina 10A and Tina 8A is achieved using a cable with M12 connectors on each end.

The Tina 10A has two LED's which show the status of the light grid. The same status information signal is connected to the Tina 8A. Tina 10A and the Focus transmitter are connected, via an M12-3B, to Tina 8A.

### Connection 3

A Spot 10 light beam is connected directly to Tina 8A. A 'Y' connector M12-3B for M12 plugs is connected to the transmitter and the receiver. The status information shown on the Spot LED is also connected to Tina 8A.

### Connection 4

A safety mat (same for safety strip and safety bumper) is connected via a Tina 6A to the Tina 8A. Two LEDs in Tina 6A shows the status of the mat. The same status information signal is connected to Tina 8A.

### Connection 5

One Smile is connected to the Tina 8A. The information shown by an LED on the Smile is also connected to the terminal block on the Tina 8A.

### Connection 6

A safety interlock switch is connected via a Tina 3A mounted directly on the switch. The output from the Tina 3A is via a M12 connector. The connection between the Tina 3A and the Tina 8A is therefore simply made with a cable with M12 connectors on each end. On the Tina 3A there is a LED which shows the status of the switch. The same information signal is connected to the Tina 8A.

### Connection 7

A Spot 35, transmitter and receiver are connected directly to the Tina 8A via a M12-3B 'Y' connector. The status information shown by the LED on the Spot is also connected to the Tina 8A.

### Connection 8

Tina 1A is a plug which has to be connected to Tina 8A inputs when no sensor is required, in order to complete the safety connection circuit.

**Note:** All input connectors on the Tina 8A must be connected to sensors or have Tina 1A plugs fitted.

## Adaptation unit

# Tina 10<sub>A/B/C</sub>



Tina 10 A/B/C are three connection units with M12 connections, that make it easy to connect a light curtain or light beam Focus with OSSD outputs to the dynamic safety circuits of Vital and Pluto. This also enables complete external interconnections, with M12 cabling, which reduces the cabling and connections in the apparatus enclosure. Tina 10 A/B/C has LEDs for function indication, with green, red or flashing green/red indications.

**Tina 10A:** has two M12 connections that are connected to 1: Vital/Pluto and 2: a light curtain/light beam Focus receiver. See the connection examples HH3300F, HR7000L-01.

**Tina 10B:** has three M12 connections that are connected to 1: Vital/Pluto and 2: a light curtain/light beam Focus receiver, and 3: An external reset button and muting lamp, such as unit FMI-1C. See the connection examples HR7000L-01.

**Tina 10C:** has three M12 connections that are connected to 1: Vital/Pluto and 2: a light curtain/light beam Focus receiver, and 3: a light curtain/light beam Focus Transmitter. See the connection examples HH3302D, HR7000L-01.

### Approvals:



### Application:

Adaptation of safety sensors with OSSD outputs to the dynamic safety circuit.

For example:  
Focus lightcurtain/lightbeam

### Features:

Simplifies the system as well as maintaining the safety level

Indication of status by LED



Technical data – Tina 10A/B/C	
<b>Manufacturer</b> Article number/Ordering data	ABB AB/Jokab Safety, Sweden Tina 10A – 2TLA020054R1200 Tina 10B – 2TLA020054R1300 Tina 10C – 2TLA020054R1600
<b>Level of safety</b> IEC/EN 61508-1...7 EN 62061 EN ISO 13849-1 EN 954-1	SIL3 SIL3 PL e, category 4 Category 4
<b>PFH<sub>d</sub></b>	4,50×10 <sup>-9</sup>
<b>Power supply</b> Operating voltage Total current consumption  Time delay t (in/out) Voltage supply at normal operation (protection OK) and 24 VDC supply voltage	24 VDC + +20%, -20% 60 mA (70 mA with max. info signal out) Info signal out: Max. 10 mA t < 120 μs Dynamic input signal: 9 to 13 V (RMS) Dynamic output signal: 9 to 13 V (RMS) Info signal out: ~23 VDC
<b>General</b> Protection class Ambient temperature Humidity range Housing material Size Weight Colour	IP67 Storage: -10...+55° C Operation: -10...+55° C 35 to 85 % (without icing or condensation) Based on polyamide, Macromelt OM646 (V0) 74 × 36 × 11 mm (L × W × H) ~40 g Black
<b>Number of units connected to Vital 1</b> Max. number of Tina 10A: Max. number of Tina 10B/C:	6 4 when Focus is supplied by Vital and a reset lamp is used 6 when Focus is supplied separately or no reset lamp is used
<b>Number of units connected to Pluto, Vital 2 or 3, per input</b> Max. number of Tina 10A/B/C:	2

<b>Connectors</b> Tina 10A	1: for Vital or Pluto 2: for Focus receiver
Tina 10B	1: for Vital or Pluto 2: for Focus receiver 3: for Reset unit
Tina 10C	1: for Vital or Pluto 2: for Focus receiver 3: for Focus transmitter
<b>Approved standards</b>	European Machinery Directive 2006/42/EC EN ISO 12100-1:2003, EN ISO 12100-2:2003, EN 60204-1:2007, EN 954-1:1996, EN ISO 13849-1:2008, EN 62061:2005, EN 61496-1:2004 + A1:2008
<b>Certificates</b>	TÜV Nord

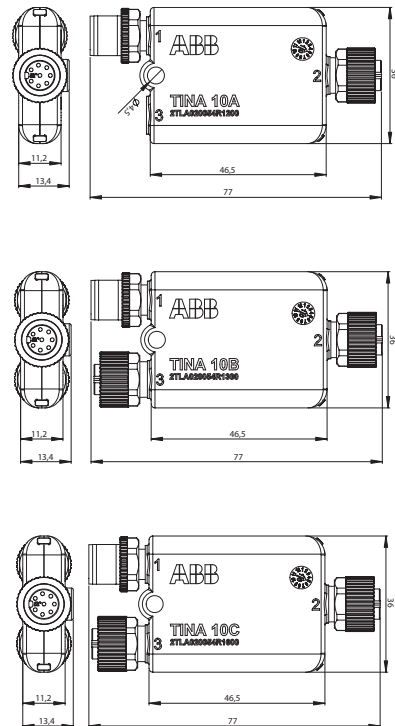

## Tina 10A, 10B and 10C connections

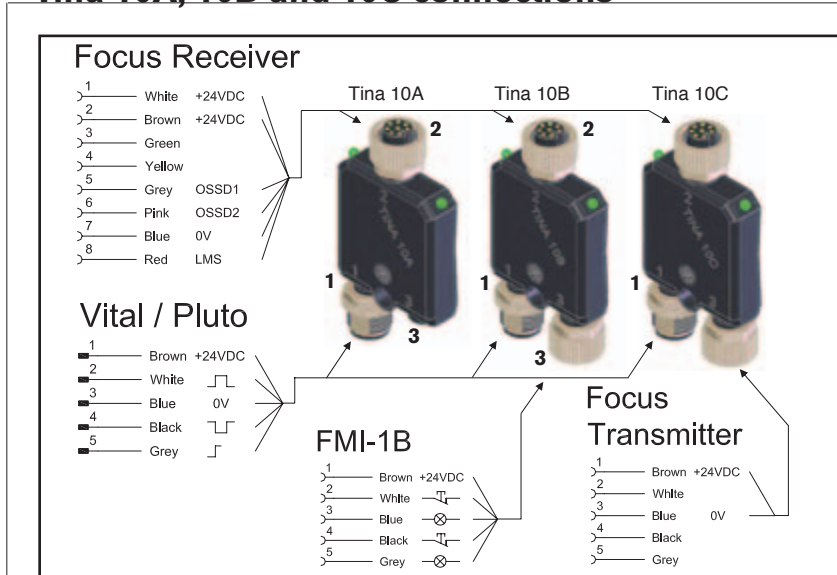

# Terminal block

# Tina 11A



Tina 11A is a connection block with two 5-pin M12 connections. It is used to connect two safety sensors with M12 contacts via a single cable to a controller or PLC. This simplifies cable running and reduces cable costs. Multiple connection blocks can be connected to a Vital/Pluto.

## Approvals:



## Application:

Terminal block for connection of two safety sensors with 5-pin M12 connectors and adaptation to the dynamic safety circuit.

## Features:

Simplifies cable routing and reduces cable costs.

Allows connection of two safety sensors to the dynamic safety circuit.

Technical data – Tina 11A	
<b>Manufacturer</b> Article number/Ordering data	ABB AB/Jokab Safety, Sweden 2TLA020054R1700 Tina 11A
<b>Level of safety</b> IEC/EN 61508-1...7 EN 62061 EN ISO 13849-1 EN 954-1	SIL3 SIL3 PL e, category 4 Category 4
<b>PFH<sub>d</sub></b>	4,50 × 10 <sup>-9</sup>
<b>Power supply</b> Operating voltage Total current consumption  Time delay t (in/out) Voltage supply at normal operation (protection OK) and 24 VDC supply voltage	24 VDC + +15%, -15% 17 mA (27 mA with max information output) Information output: Max 10 mA t < 60 μs Dynamic input: between 9 and 13 volt (RMS) Dynamic output: between 9 and 13 volt (RMS) Information output: ~ 23 VDC
<b>General</b> Protection class Ambient temperature Humidity range Housing material Connectors	IP67 Storage: -30...+70°C Operation: -10...+55°C 35 to 85 % (with no icing or condensation) Based on polyamide, Macromelt OM646 (V0) Out: M12 5-pole male (nr 2) In: M12 5-pole female (nr 1,3)
<b>Size</b> Weight Colour	74 × 36 × 11 mm (L × W × H) ~40 g Black

<b>Approved standards</b>	European Machinery Directive 2006/42/EC EN ISO 12100-1:2003, EN ISO 12100-2:2003, EN 60204-1:2007, EN 954-1:1996, EN ISO 13849-1:2008, EN 62061:2005
<b>Certificates</b>	TÜV Nord

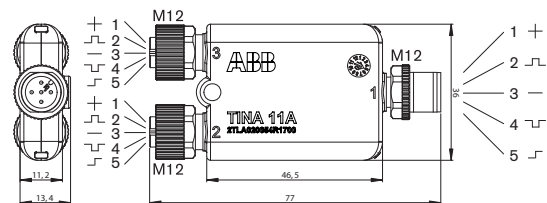

### 5-pin M12 female connector (contact #2-3)

1. +24 VDC
2. Dynamic input signal
3. 0 VDC
4. Dynamic output signal
5. Information

### 5-pin M12 male connector (contact #1):

1. +24 VDC
2. Dynamic input signal
3. 0 VDC
4. Dynamic output signal
5. Summarized information (contact #2-3)

# Terminal block

# Tina 12A



Tina 12A is a connection block with two 8-pin M12 connections. It is used to connect two process locks Dalton or Magne 2A/B with integrated Eden sensors via a single cable to a controller or PLC. This simplifies cable running and reduces cable costs. Multiple connection blocks can be connected to a Vital/Pluto.

- Tina 12A has three 8-pin M12 contacts that connect to
- 1: Pluto/Vital, information for sensors and locks and lock signals
  - 2: Dalton with Eden No 1
  - 3: Dalton with Eden No 2

Technical data – Tina 12A	
<b>Manufacturer</b> Article number/Ordering data	ABB AB/Jokab Safety, Sweden 2TLA020054R1800 Tina 12A
<b>Level of safety</b> IEC/EN 61508-1...7 EN 62061 EN ISO 13849-1 EN 954-1	SIL3 SIL3 PL e, category 4 Category 4
<b>PFH<sub>d</sub></b>	4,50 × 10 <sup>-9</sup>
<b>Power supply</b> Operating voltage Total current consumption  Time delay t (in/out) Voltage supply at normal operation (protection OK) and 24 VDC supply voltage	24 VDC + +15%, -15% 60 mA (70 mA with max information output) Information output: Max 10 mA t < 60 μs Dynamic input: between 9 and 13 volt (RMS) Dynamic output: between 9 and 13 volt (RMS) Information output: ~ 23 VDC
<b>General</b> Protection class Ambient temperature Humidity range Housing material Connectors	IP67 Storage: -30...+70°C Operation: -10...+55°C 35 to 85 % (with no icing or condensation) Based on polyamide, Macromelt OM646 (V0) To Vital/Pluto: M12 8-pole male (nr 2) From safety device: M12 8-pole female (nr 1,3)

<b>Size</b>	74 × 36 × 11 mm (L × W × H)
<b>Weight</b>	~40 g
<b>Colour</b>	Black
<b>Approved standards</b>	European Machinery Directive 2006/42/EC EN ISO 12100-1:2003, EN ISO 12100-2:2003, EN 60204-1:2007, EN 954-1:1996, EN ISO 13849-1:2008, EN 62061:2005
<b>Certificates</b>	TÜV Nord

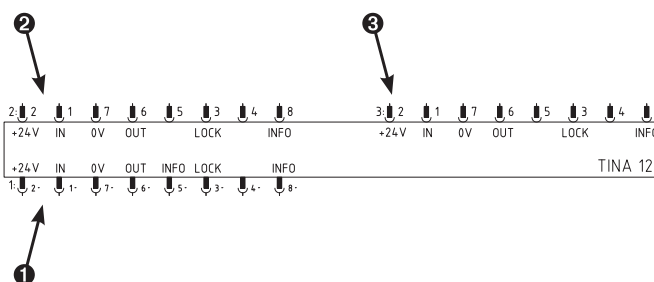
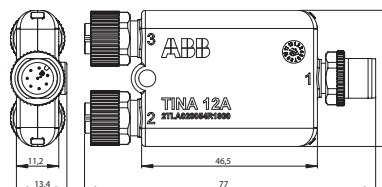

## Approvals:



## Application:

Terminal block for connection of two safety sensors with 8-pin M12 connectors and adaptation to the dynamic safety circuit.

For example:

- Dalton
- Magne
- Knox

## Features:

Simplifies cable routing and reduces cable costs.

Allows connection of two safety sensors to the dynamic safety circuit.

# Accessories

## 'Y' branch with M12 connection and M12-connection device with screw connectors

### M12-3A

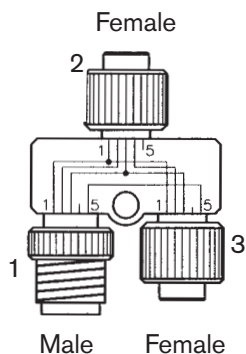

See the connection examples HA3306C, D – chap. 3. HH3300A, D – chap. 3.

### M12-3B

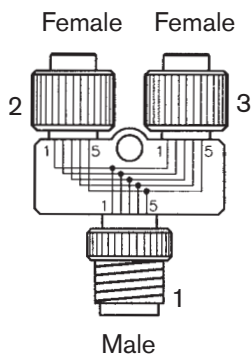

See the connection examples HA3306C, D. HH3300D, F. HH3302D – chap. 3.

### M12-3D

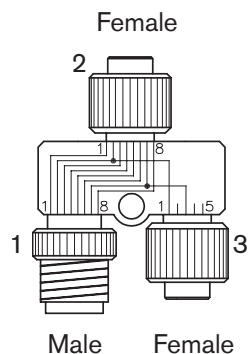

See the connection examples HB0008A – chap. 5. HR7000O, L. – chap. 4.

### M12-3E

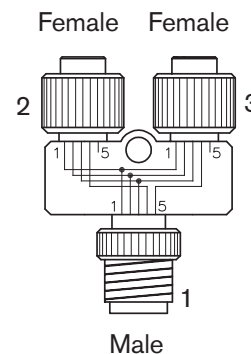

See the connection examples HB0001A, 2A, 4A and 6A – chap. 3.

See product list for applications

### M12-C01

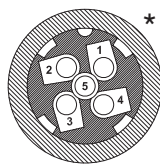

Female

### M12-C02

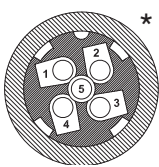

Male

### M12-C03

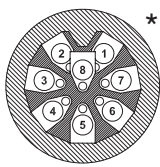

Female

### M12-C04

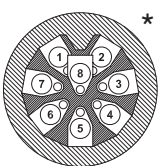

Male

\* Seen from the cable connection side

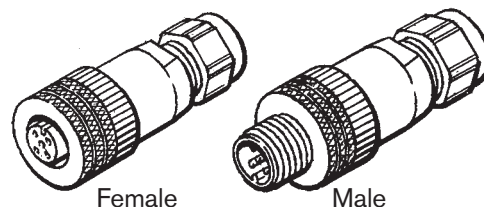

Female

Male

## Cabling



Many of ABB Jokab Safety's products are connected using standard M12 connectors. This facilitates installation, saving a lot of time, and also dramatically reduces the risk of incorrect connection.

We have therefore developed cables with 5 conductors, 5 x 0.34 mm + screening or 8 conductors; 8 x 0.34 mm + screening which offer the advantages that we believe a good cable should have. These are available in any length and in various standard lengths, with moulded straight or angled male or female connectors. Particularly suitable cables for the Tina 4A and Tina 8A units are C9 and C13. They have thicker, 0.75 mm<sup>2</sup> conductors for the feed line and 0.5 mm<sup>2</sup> for the other conductors + screening. Refer to the component list for the variants that are available.

### Advantages:

- Area 0.34 mm<sup>2</sup>
- Always screened cable
- The screen is always connected to negative in male connectors.
- The guide pin in the small connector is indicated by a recessed arrow that is easy to recognise.
- Convenient cable in PVC
- The cable is also available in any length

# Example of safety sensors connections based on 'Y' branch

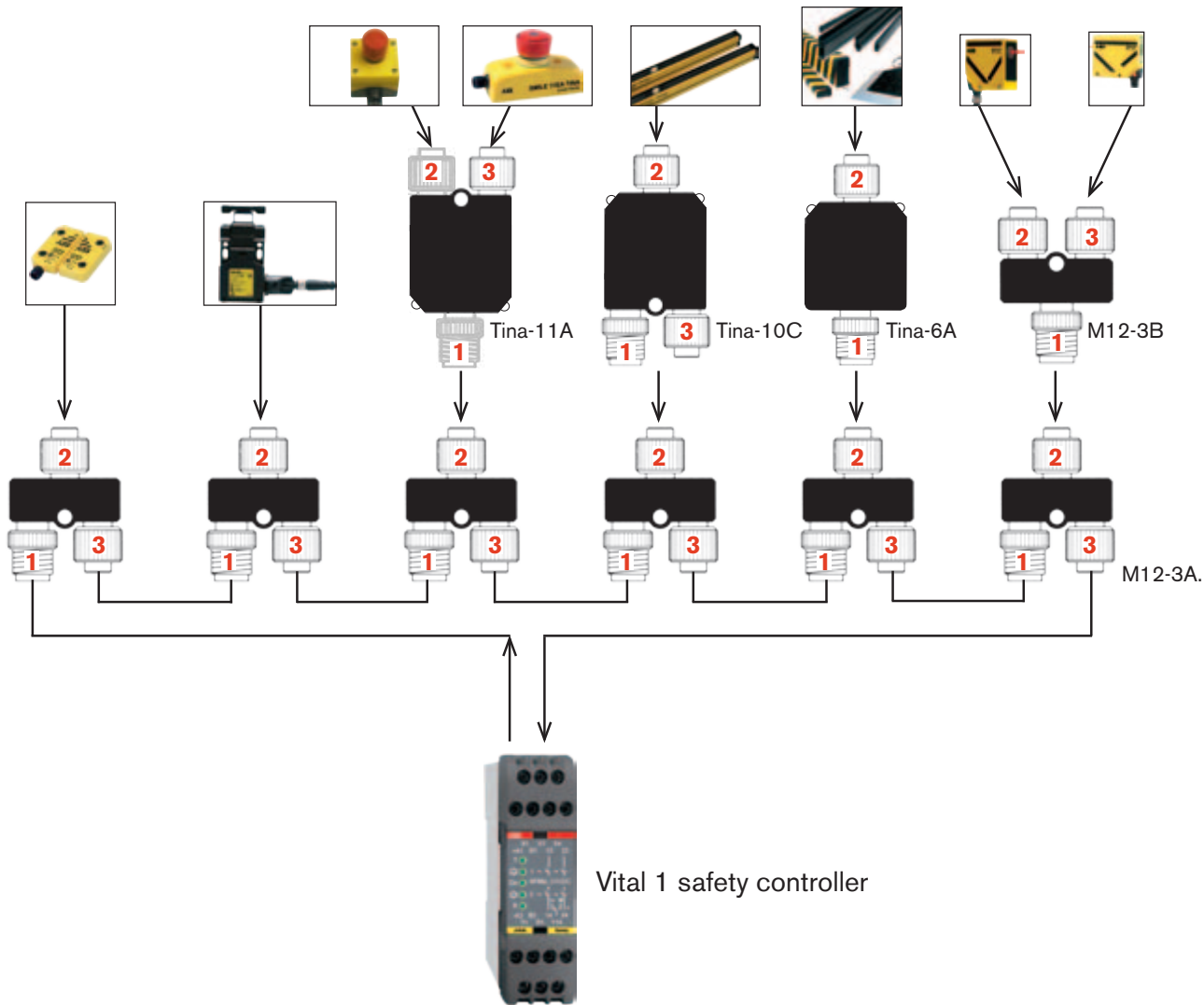

<b>Contents</b>	<b>Page</b>
HA3300A-01 Connection example Vital 1 _____	5:41
HA3301A Vital 1 with several Eden _____	5:41
HA3302A Vital 1 and Tina 4A with 4 Eden _____	5:42
HA3302B Vital 1 and 2 Tina 4A and 4 Eden and emergency stop _____	5:42
HA3303A Vital 1 with emergency stop/Tina 2A _____	5:43
HA3304A Vital 1 with emergency stop/Tina 3A _____	5:43
HA3305A Vital 1 with Eden and lightgrid Focus/Tina 10C _____	5:44
HA3306C Vital 1 with 2 lightbeams Spot _____	5:44
HA3306D Vital 1 with 3 lightbeams Spot _____	5:45
HA3307A Vital 1 with Eden, lightgrid/Tina 3A and emergency stop/Tina 7A _____	5:45
HD3800A-01 Vital 1 with safety light beam Spot _____	5:46
HD3801A-01 Vital 1, series and parallel _____	5:46
HE3811B-01 Safety light beam Spot with time-limited reset _____	5:47
HE3824C-01 Lightbeam with time-limited bypass 0.2–40 s. _____	5:47
HE3824D-01 Eden and bypassed lightbeam with Eden _____	5:48
HE3824E-01 Lightbeams with time-limited bypass 0.2–40 s. _____	5:48
HE3824F-01 Eden and 2 bypass lightbeams with Eden _____	5:49
HE3824G-01 Eden and 2 separately bypassed lightbeams _____	5:49
HH3300A Vital 1 with different types of safety devices and M12–3A _____	5:50
HH3300D Vital 1 with Tina 4A and different types of safety devices _____	5:50
HH3302D Vital 1 with Tina 8A and different types of safety devices _____	5:51
HH3301E Connection example Vital 1 _____	5:51
HH3400A2 Vital 1 Solutions _____	5:52
HB0005A Vital with Eden and Inca emergency stop, with separate reset _____	5:52
HB0006A Vital with 4 Eden units + Reset via M12-3E and Tina 4A _____	5:53
HB0007A Vital with two Dalton units via Tina 12A _____	5:53
HB0001A Pluto with Smile emergency stop unit + Reset via M12-3E and Adam via Tina 4A _____	5:54
HB0002A Pluto with five Eden units, for two zones via M12-3E and Tina 4A _____	5:54
HB0003A Pluto with Smile and Inca emergency stop units, via Tina 11A and Tina 4A _____	5:55
HB0004A Pluto with different zones for Eden + Reset and two Eden units + via M12-3E _____	5:55
HH3301D Connection example – Vital 1 and Tina 8A with different safety device types _____	5:56
HH3300F Vital 1 with Tina 8B Profibus and different types of safety devices _____	5:56



# HA3300A-01 Connection example Vital 1

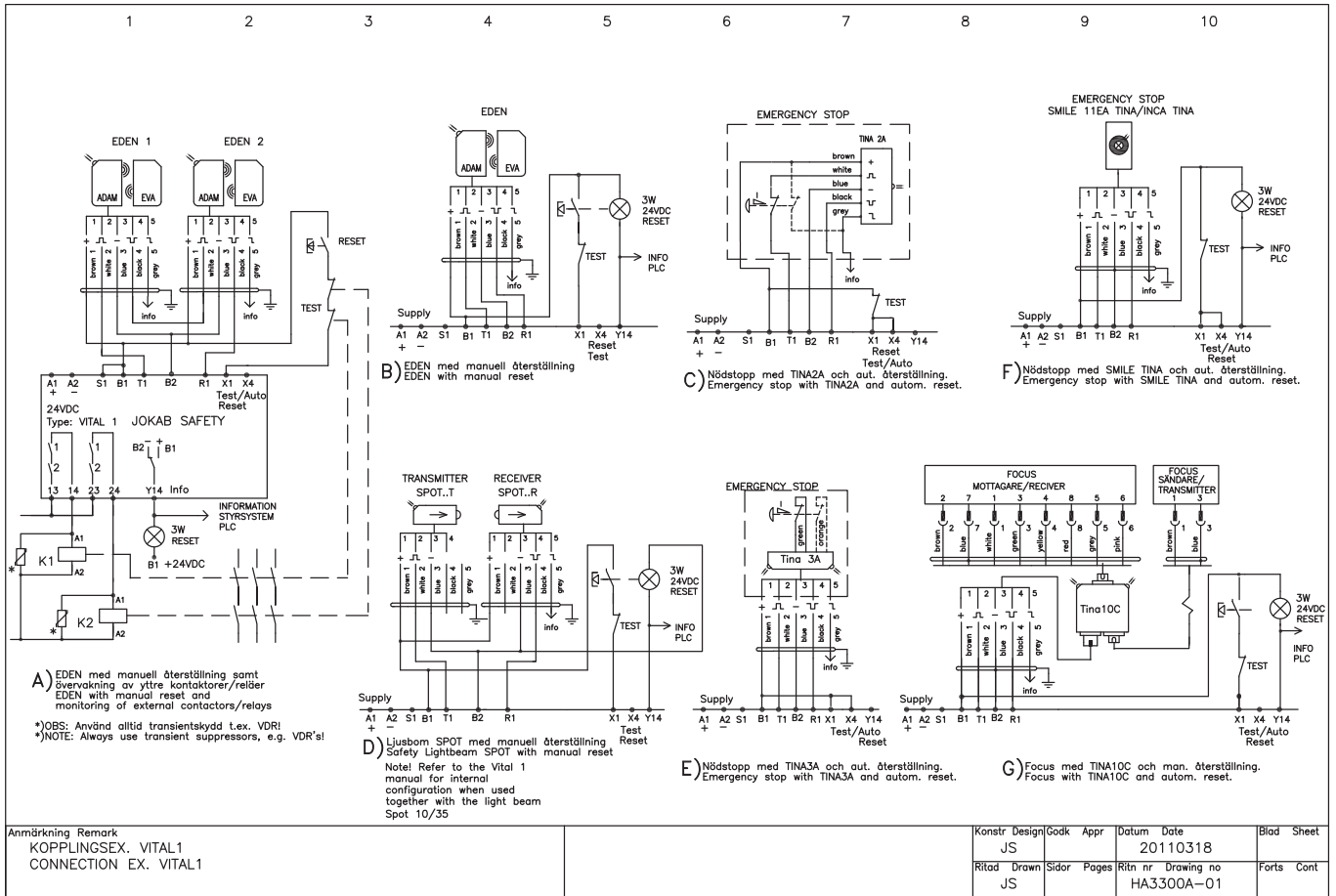

It is the user's responsibility to ensure that all control devices are correctly installed, cared for and operated to meet European, national and local codes/regulations. Subject to change without notice.

# HA3301A Vital 1 with several Eden

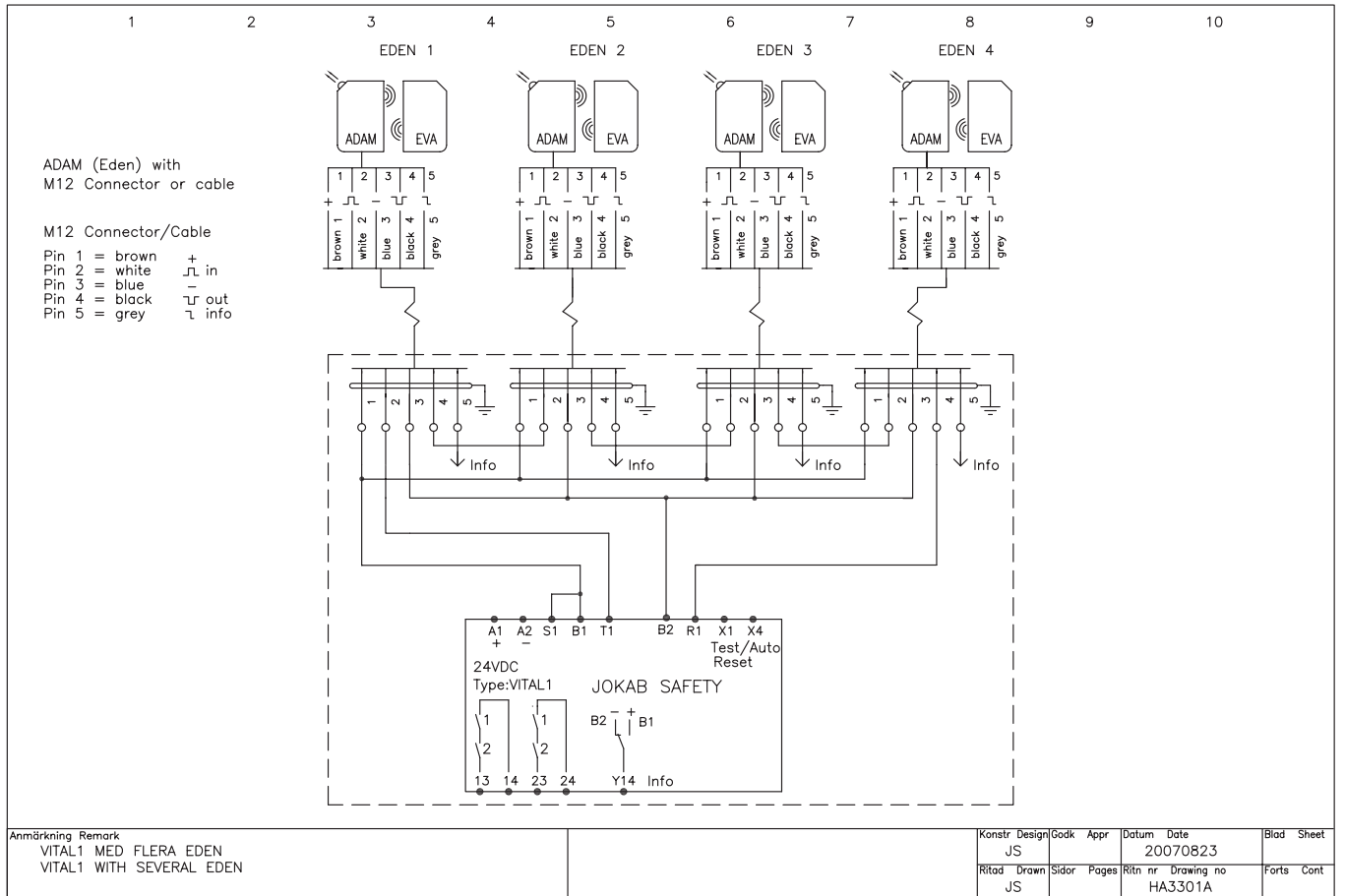

It is the user's responsibility to ensure that all control devices are correctly installed, cared for and operated to meet European, national and local codes/regulations. Subject to change without notice.

# HA3302A Vital 1 and Tina 4A with 4 Eden

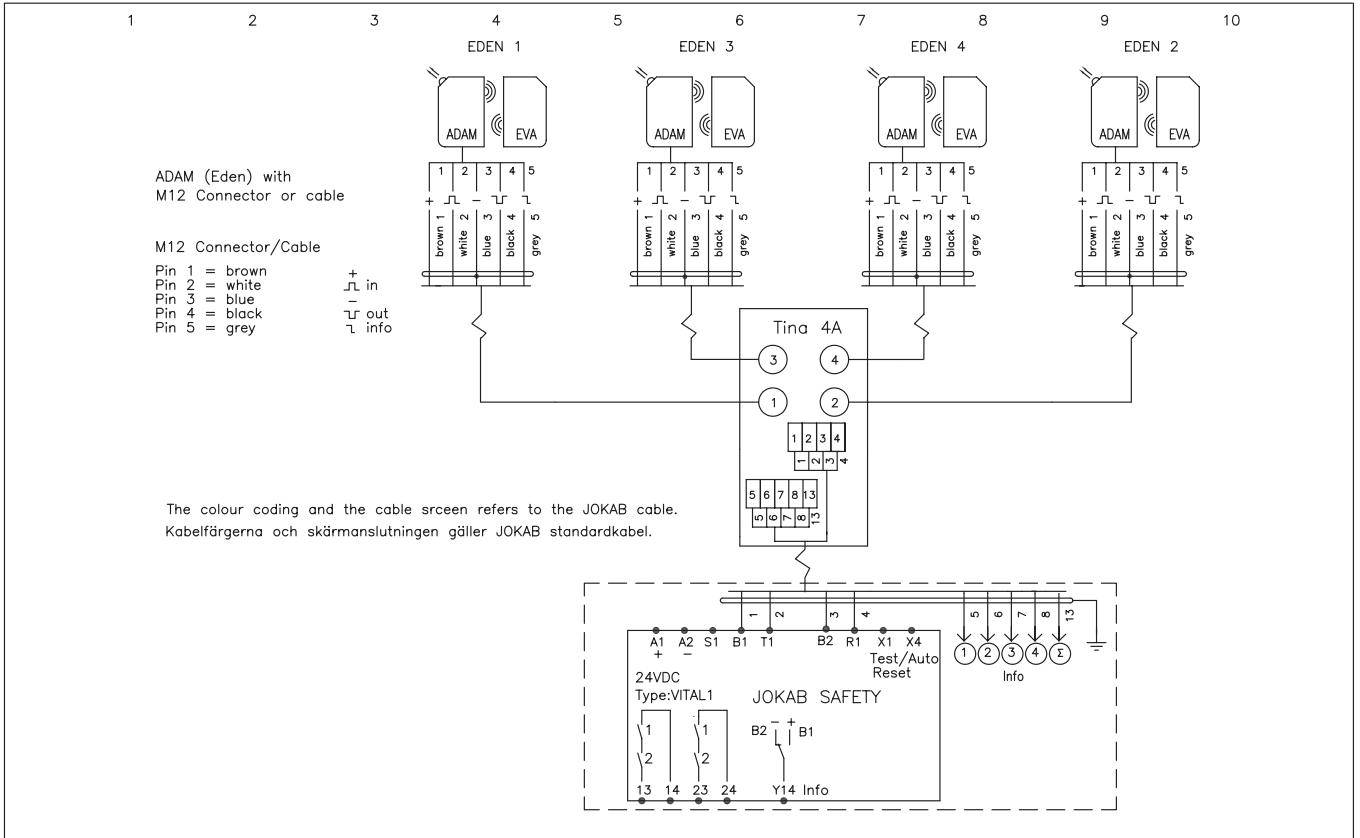

Anmärkning Remark VITAL1 OCH TINA 4A MED 4 EDEN VITAL1 AND TINA 4A WITH 4 EDEN	Konstr Design Godk Appr	Datum Date	Blad Sheet
	JS	20070709	
	Ritad Drawn Sidor Pages	Ritn nr Drawing no	Forts Cont
	JS	HA3302A	

It is the user's responsibility to ensure that all control devices are correctly installed, cared for and operated to meet European, national and local codes/regulations. Subject to change without notice.

# HA3302B Vital 1 and 2 Tina 4A and 4 Eden and emergency stop

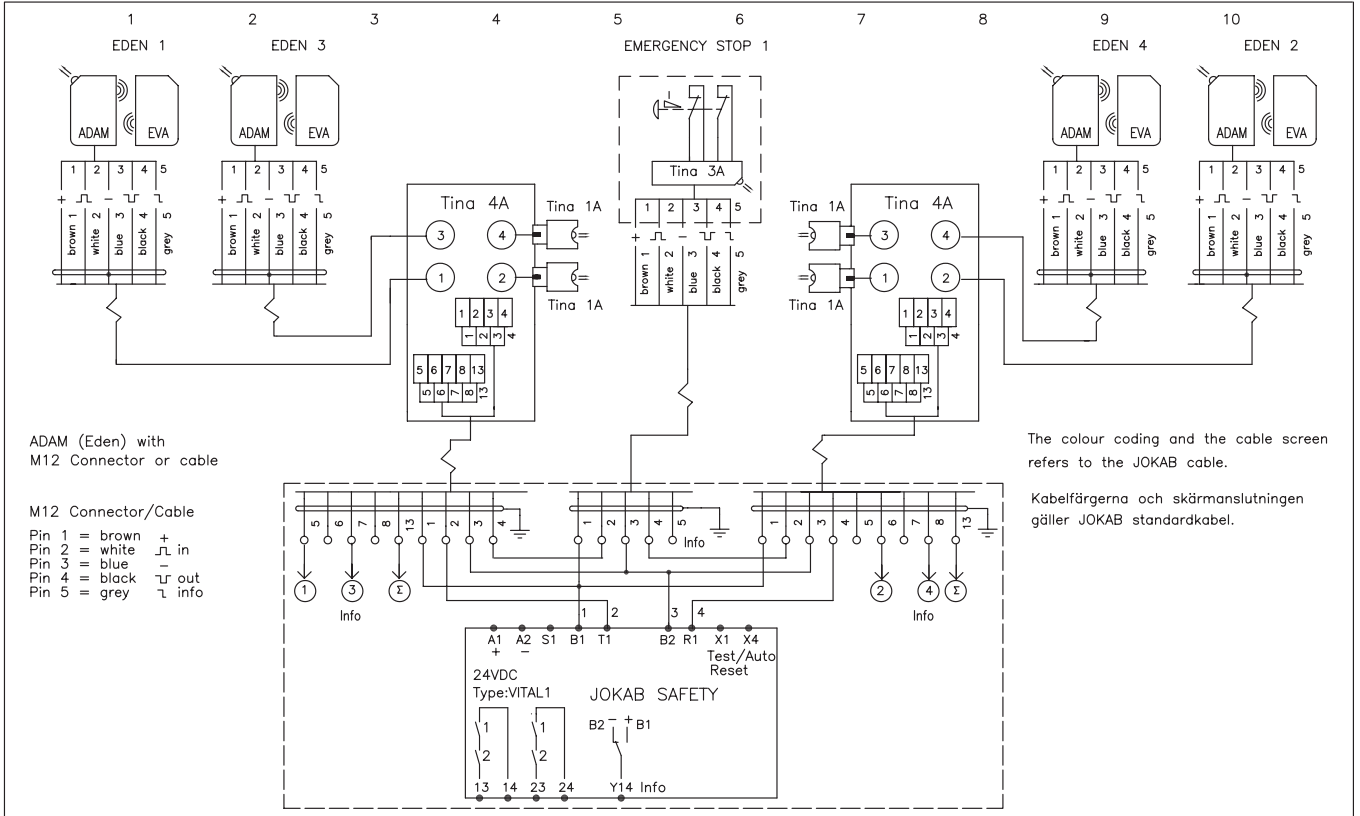

Anmärkning Remark VITAL1 OCH 2 TINA 4A MED 4 EDEN OCH NÖDSTOPP VITAL1 AND 2 TINA 4A WITH 4 EDEN AND EMERGENCY STOP	Konstr Design Godk Appr	Datum Date	Blad Sheet
	JS	20070709	
	Ritad Drawn Sidor Pages	Ritn nr Drawing no	Forts Cont
	JS	HA3302B	

It is the user's responsibility to ensure that all control devices are correctly installed, cared for and operated to meet European, national and local codes/regulations. Subject to change without notice.

# HA3303A Vital 1 with emergency stop/Tina 2A

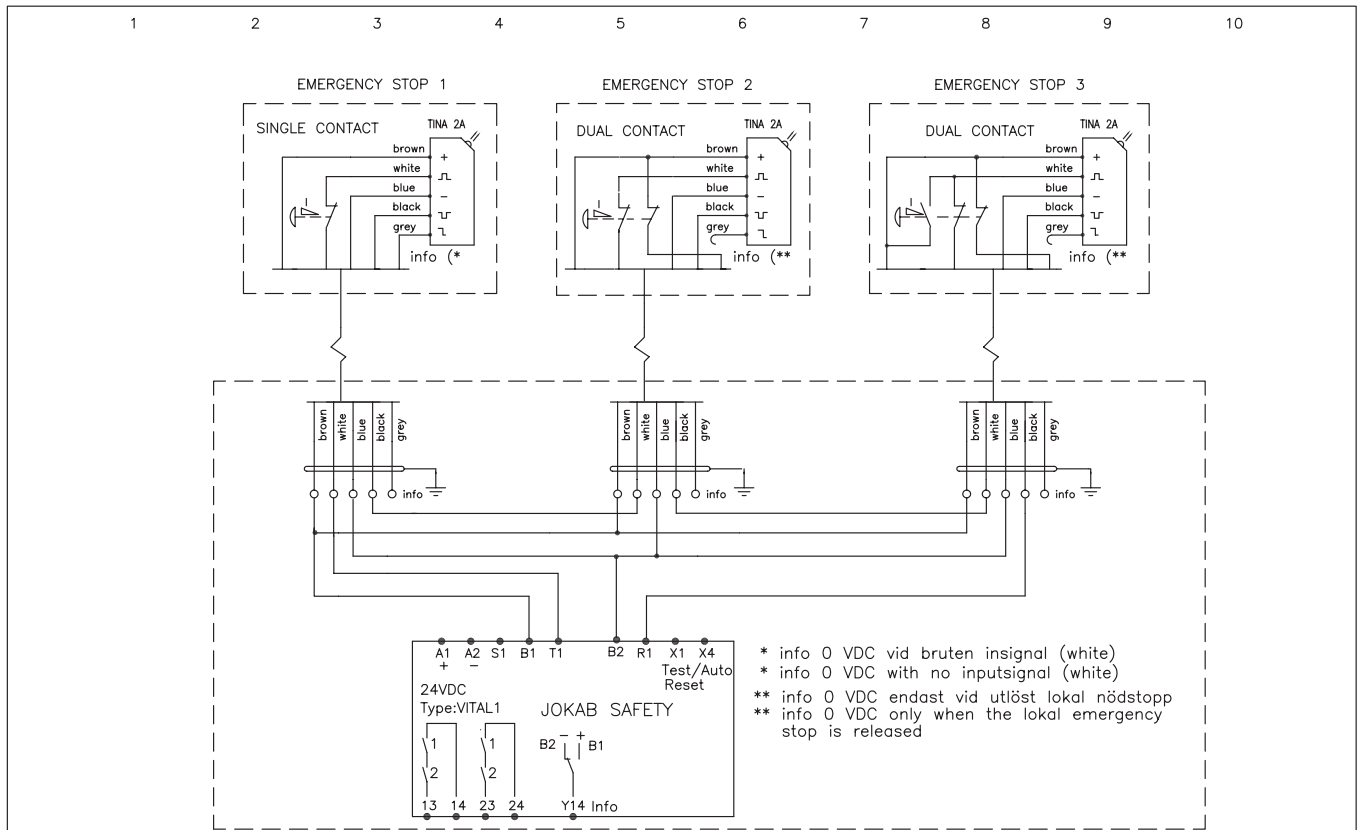

Anmärkning Remark VITAL1 MED NÖDSTOPP/TINA 2A VITAL1 WITH EMERGENCY STOP/TINA 2A	Konstr Design	Godk Appr	Datum Date	Blad Sheet
	JS	JS	20070911	
	Ritad Drawn	Sidor Pages	Ritn nr Drawing no	Forts Cont
	JS		HA3303B	

It is the user's responsibility to ensure that all control devices are correctly installed, cared for and operated to meet European, national and local codes/regulations. Subject to change without notice.

# HA3304A Vital 1 with emergency stop/Tina 3A

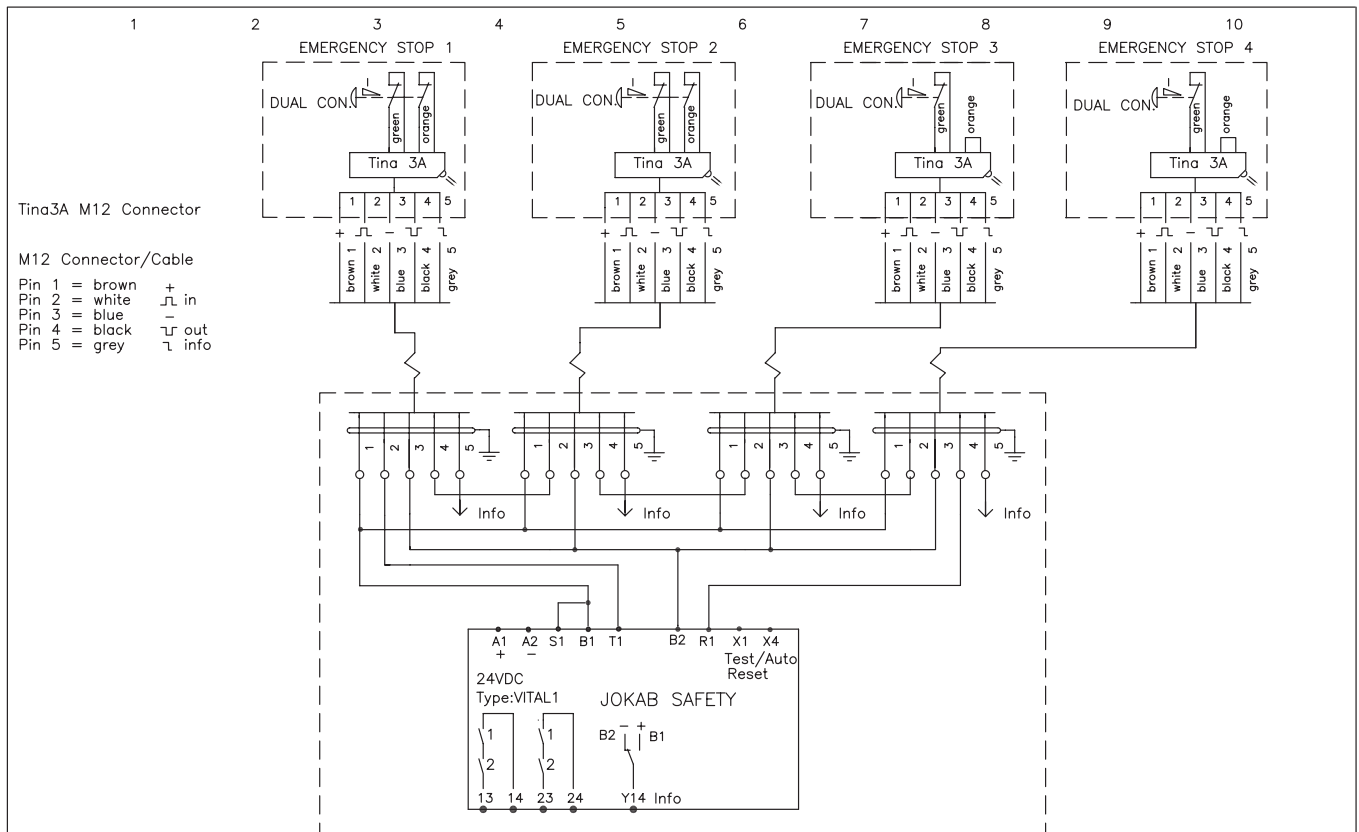

Anmärkning Remark VITAL1 MED NÖDSTOPP/TINA 3A VITAL1 WITH EMERGENCY STOP/TINA 3A	Konstr Design	Godk Appr	Datum Date	Blad Sheet
	JS	JS	20070823	
	Ritad Drawn	Sidor Pages	Ritn nr Drawing no	Forts Cont
	JS		HA3304A	

It is the user's responsibility to ensure that all control devices are correctly installed, cared for and operated to meet European, national and local codes/regulations. Subject to change without notice.

# HA3305A Vital 1 with Eden and lightgrid Focus/Tina 10C

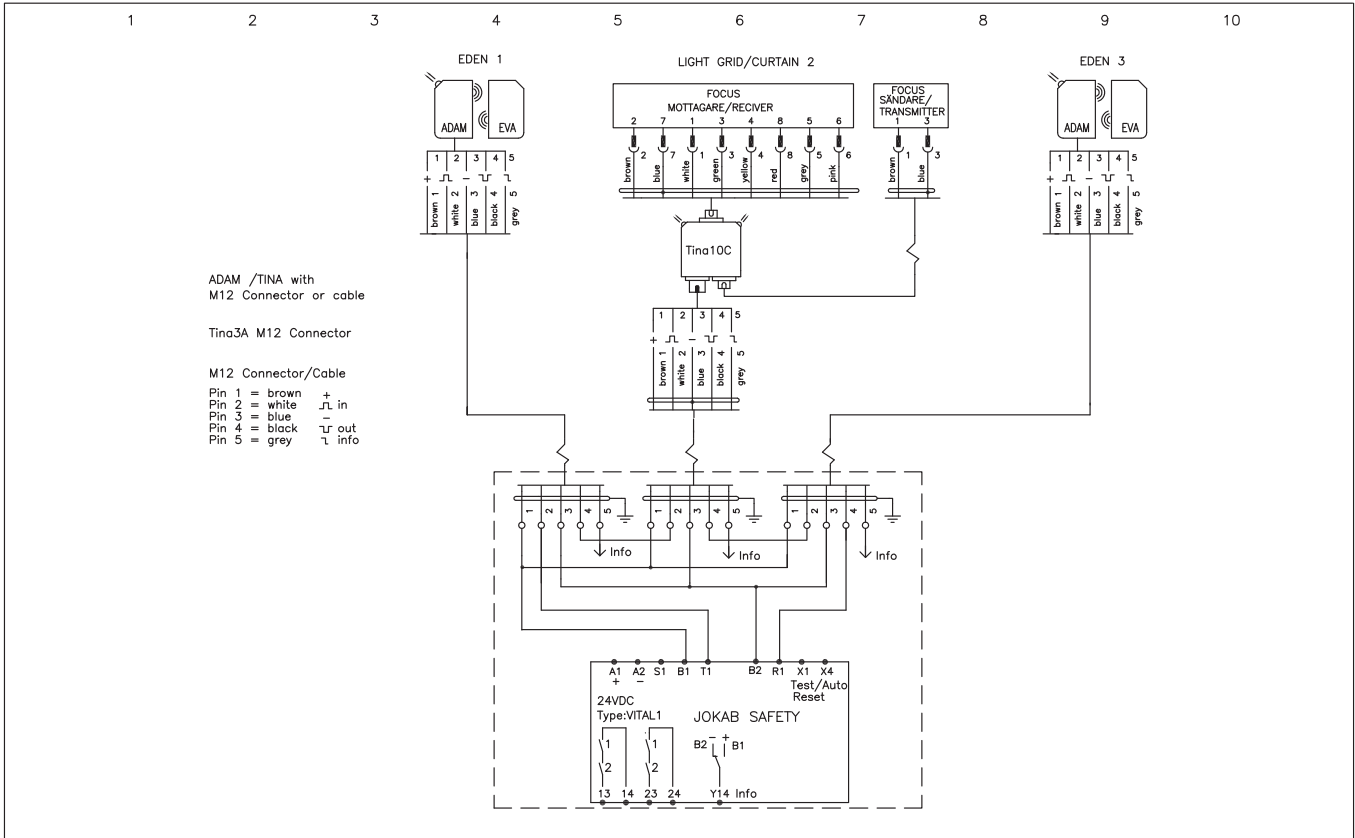

Anmärkning Remark VITAL1 MED EDEN OCH FOCUS/TINA 10C VITAL1 WITH EDEN AND FOCUS/TINA 10C	Konstr Design	Godk Appr	Datum Date	Blad Sheet
	Ritad Drawn	Sidor Pages	Ritn nr Drawing no	Forts Cont
	JS	JS	20080328	
	JS		HA3305A	

It is the user's responsibility to ensure that all control devices are correctly installed, cared for and operated to meet European, national and local codes/regulations. Subject to change without notice.

# HA3306C Vital 1 with 2 lightbeams Spot

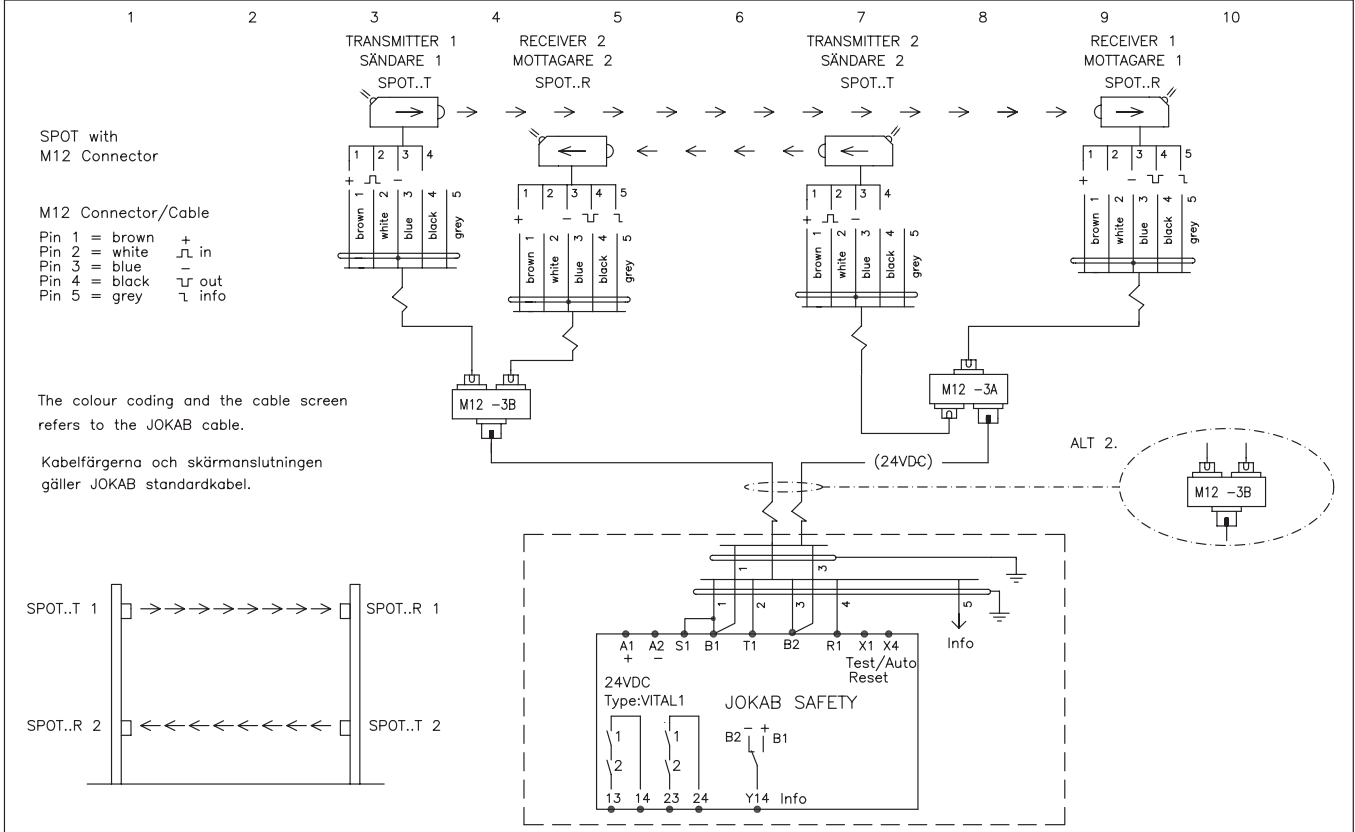

Anmärkning Remark VITAL1 MED 2 LJUSBOMMAR SPOT... VITAL1 WITH 2 LIGHTBEAMS SPOT...	Konstr Design	Godk Appr	Datum Date	Blad Sheet
	Ritad Drawn	Sidor Pages	Ritn nr Drawing no	Forts Cont
	JS	JS	020530	
	JS		HA3306C	

It is the user's responsibility to ensure that all control devices are correctly installed, cared for and operated to meet European, national and local codes/regulations. Subject to change without notice.

## HA3306D Vital 1 with 3 lightbeams Spot

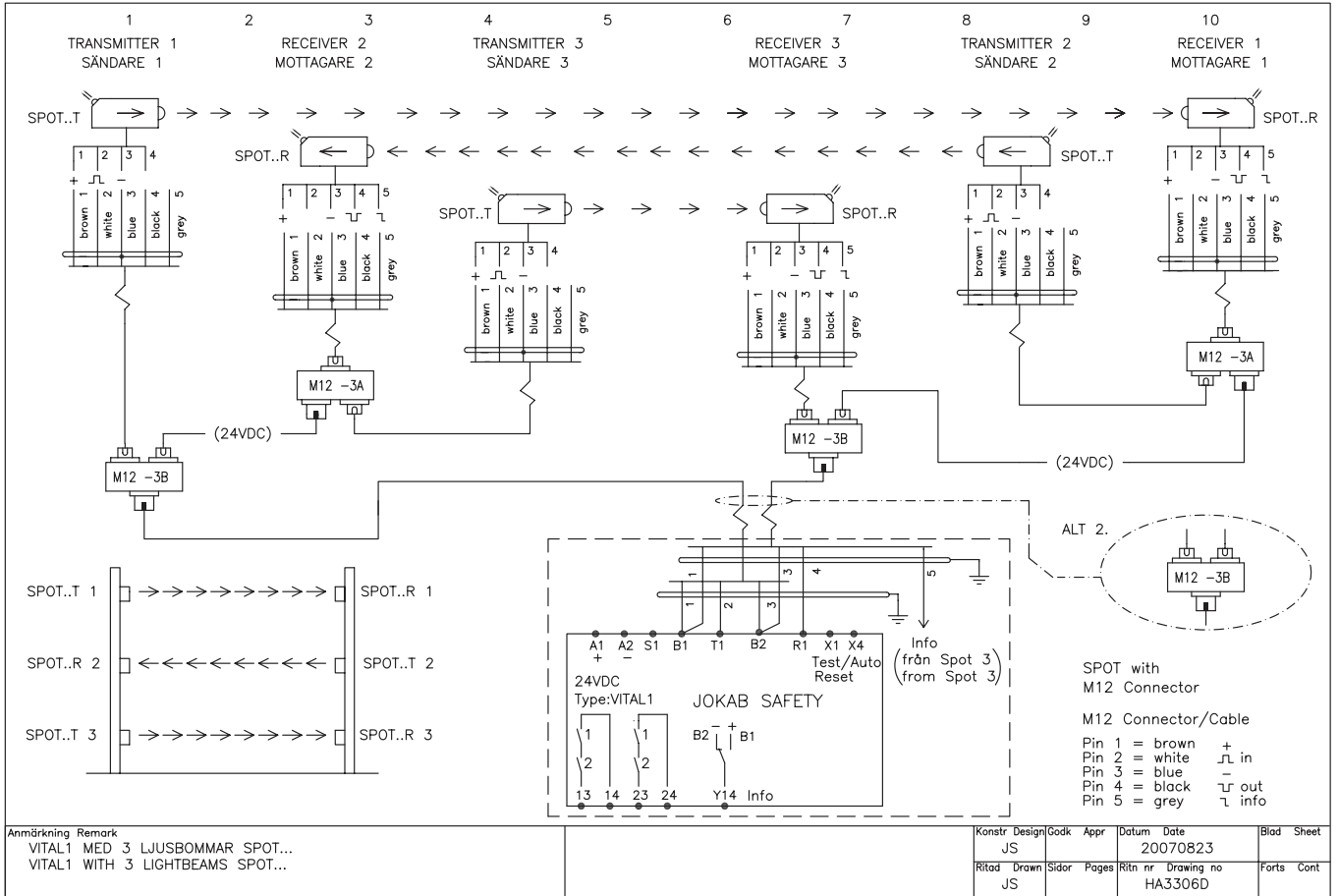

## HA3307A Vital 1 with Eden, lightgrid/Tina 3A and emergency stop/Tina 7A

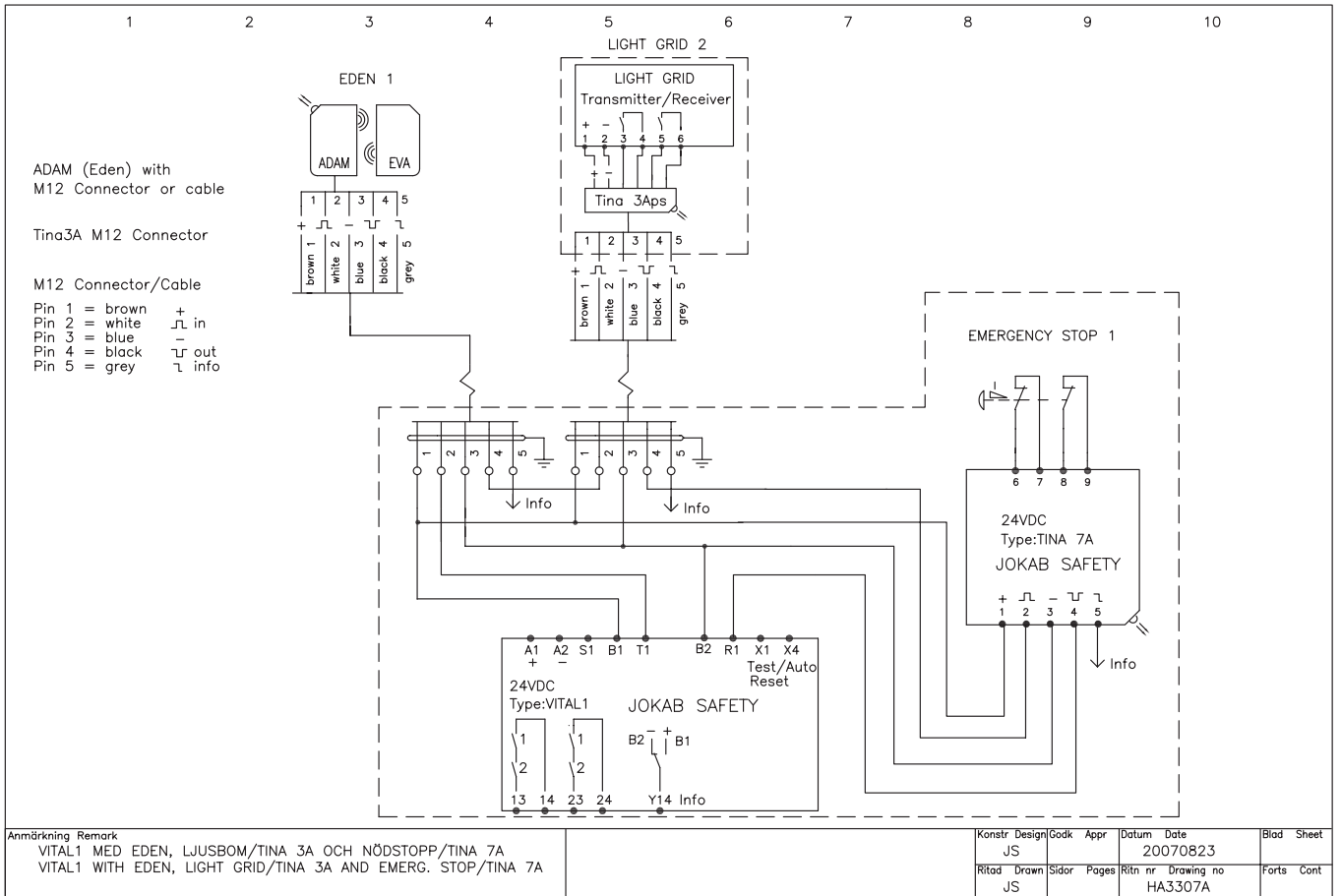

# HD3800A-01 Vital 1 with safety light beam Spot

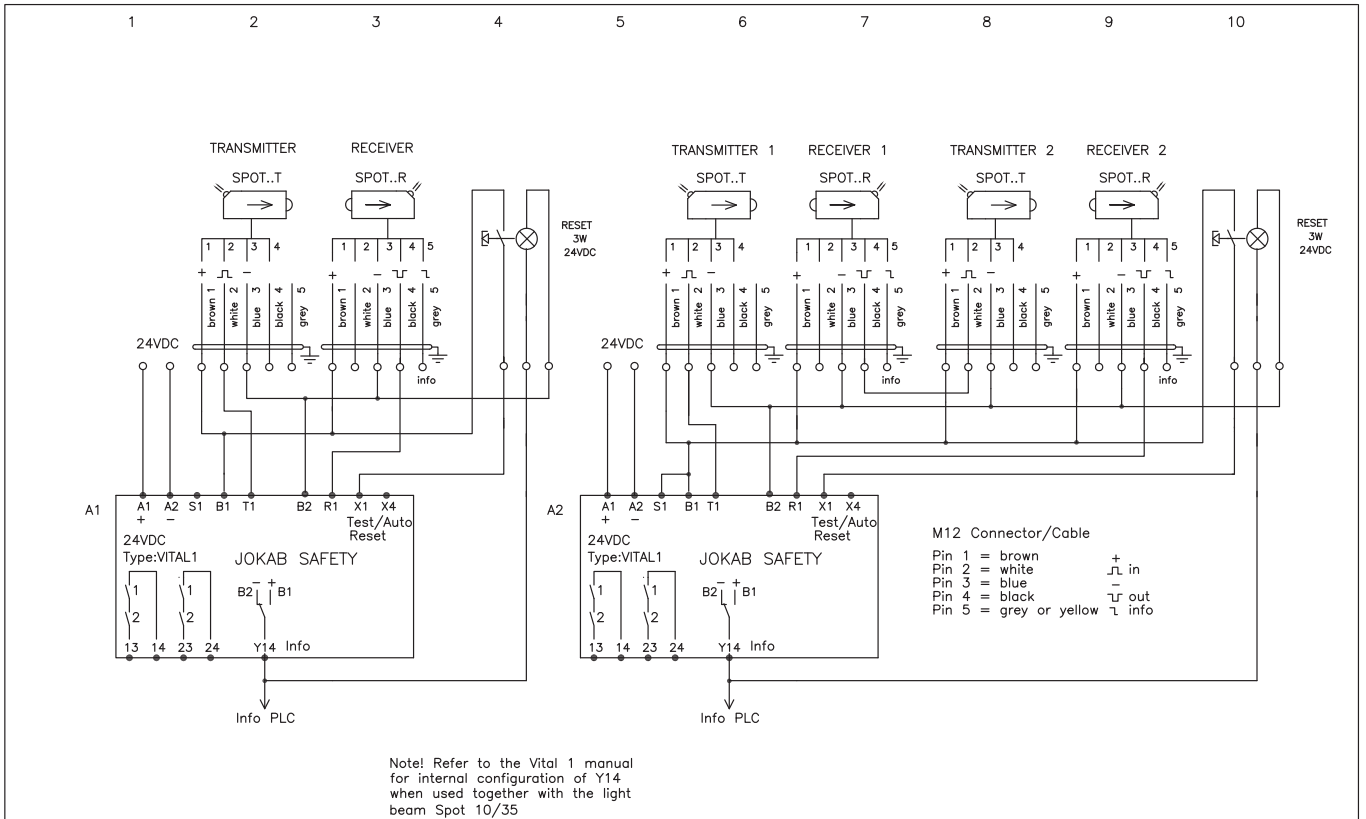

Anmärkning Remark VITAL1 MED LJUSBOM SPOT.. VITAL1 WITH SAFETY LIGHTBEAM SPOT	Konstr Design	Gödk Appr	Datum Date	Blad Sheet
	Ritad Drawn	Sidor Pages	Ritn nr Drawing no	Forts Cont
	JS		20110318	
	JS		HD3800A-01	

It is the user's responsibility to ensure that all control devices are correctly installed, cared for and operated to meet European, national and local codes/regulations. Subject to change without notice.

# HD3801A-01 Vital 1, series and parallel

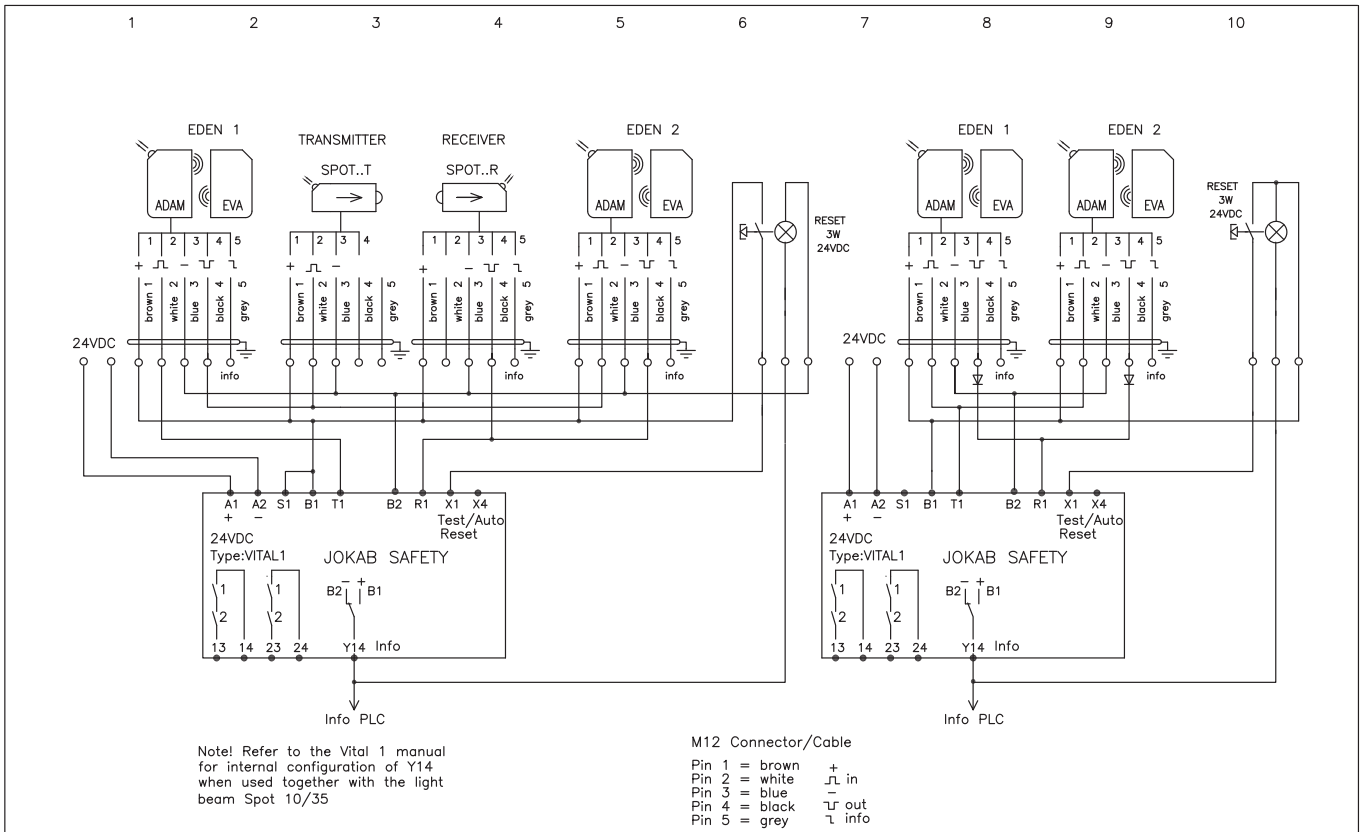

Anmärkning Remark KOPPLINGSEX. VITAL 1 SERIE OCH PARALLELL CONNECTION EX. VITAL1 SERIE AND PARALLELL	Konstr Design	Gödk Appr	Datum Date	Blad Sheet
	Ritad Drawn	Sidor Pages	Ritn nr Drawing no	Forts Cont
	JS		20110318	
	JS		HD3801A-01	

It is the user's responsibility to ensure that all control devices are correctly installed, cared for and operated to meet European, national and local codes/regulations. Subject to change without notice.



# HE3811B-01 Safety light beam Spot with time-limited reset

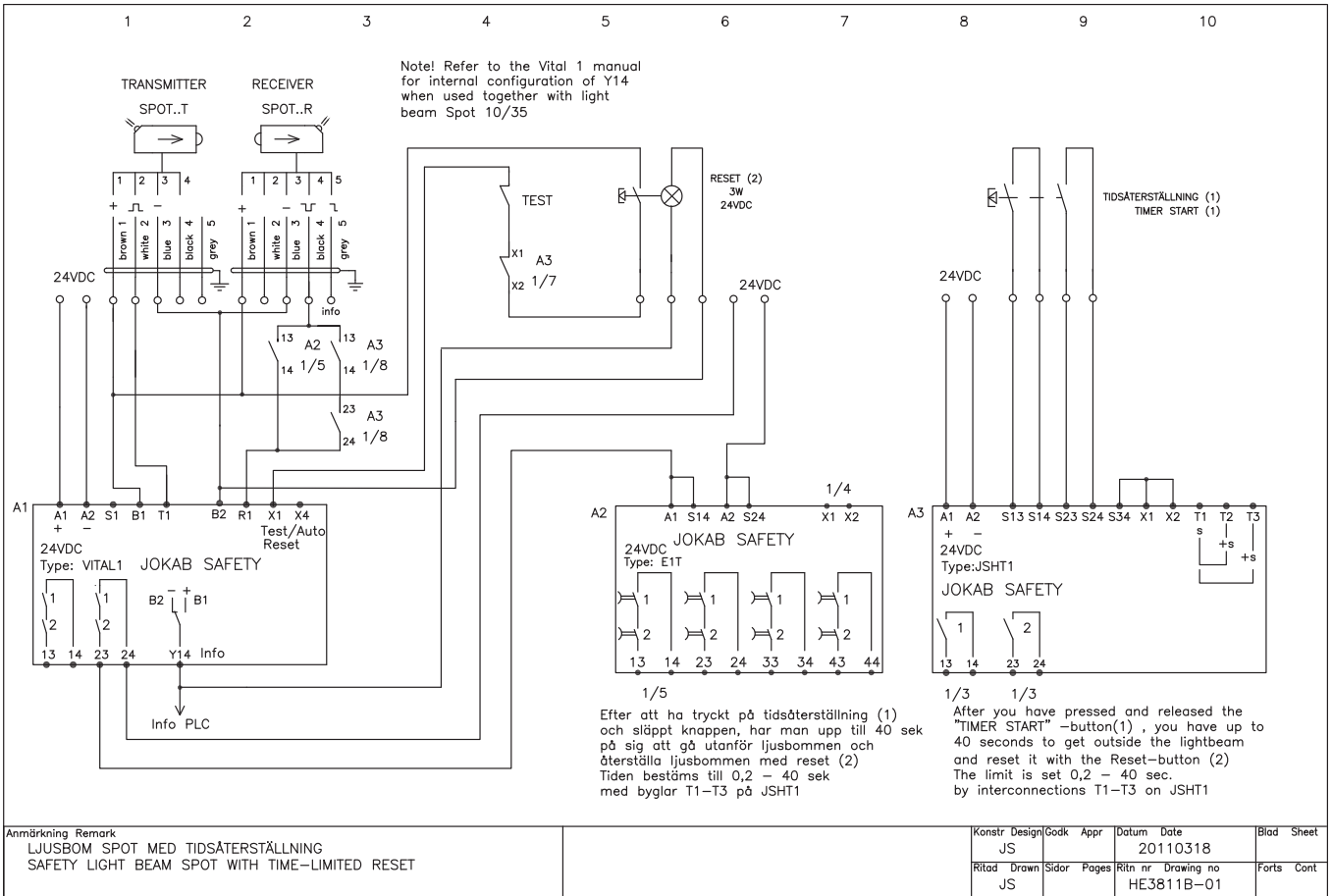

It is the user's responsibility to ensure that all control devices are correctly installed, cared for and operated to meet European, national and local codes/regulations. Subject to change without notice.

# HE3824C-01 Lightbeam with time-limited bypass 0.2-40 s.

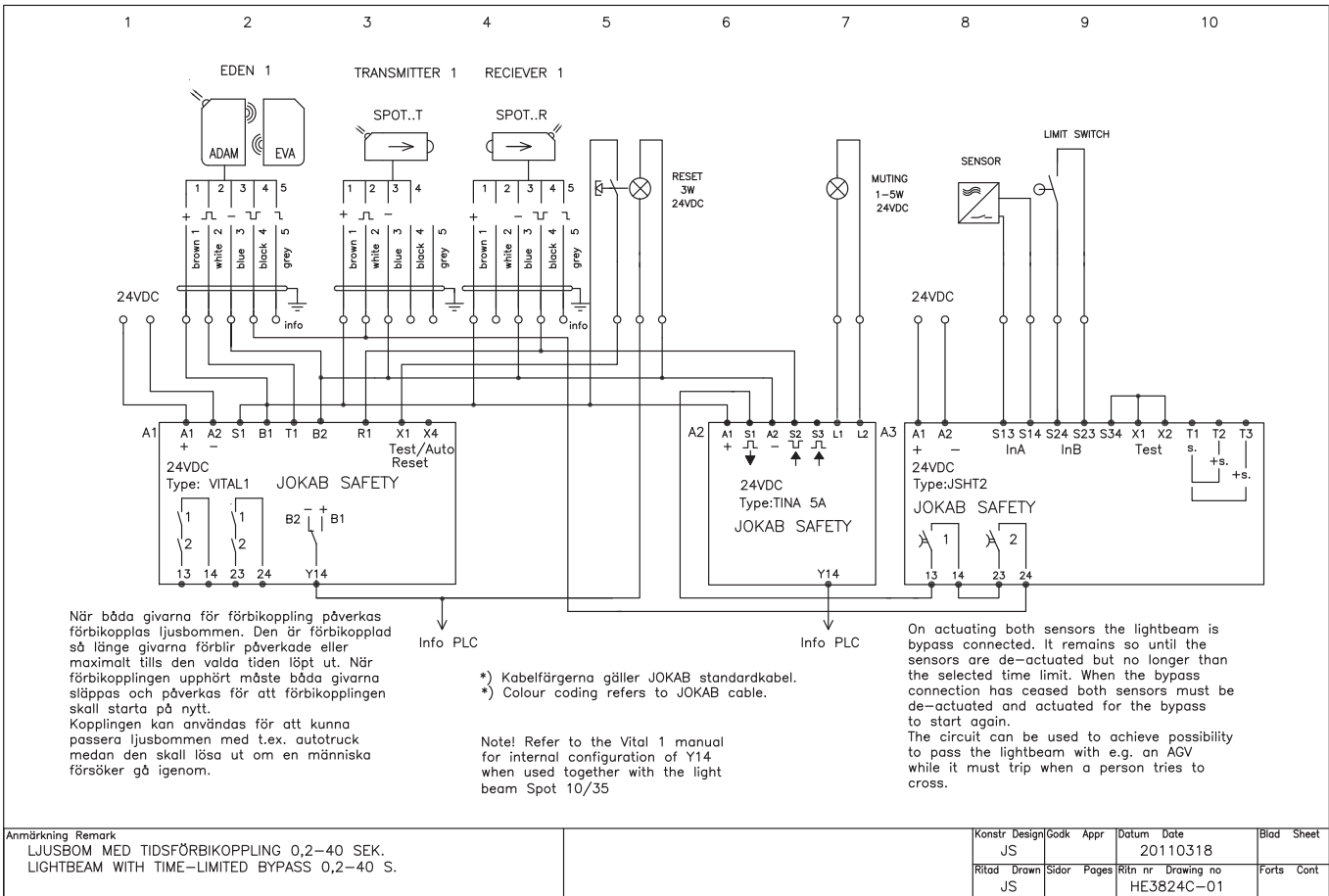

It is the user's responsibility to ensure that all control devices are correctly installed, cared for and operated to meet European, national and local codes/regulations. Subject to change without notice.

# HE3824D-01 Eden and bypassed lightbeam with Eden

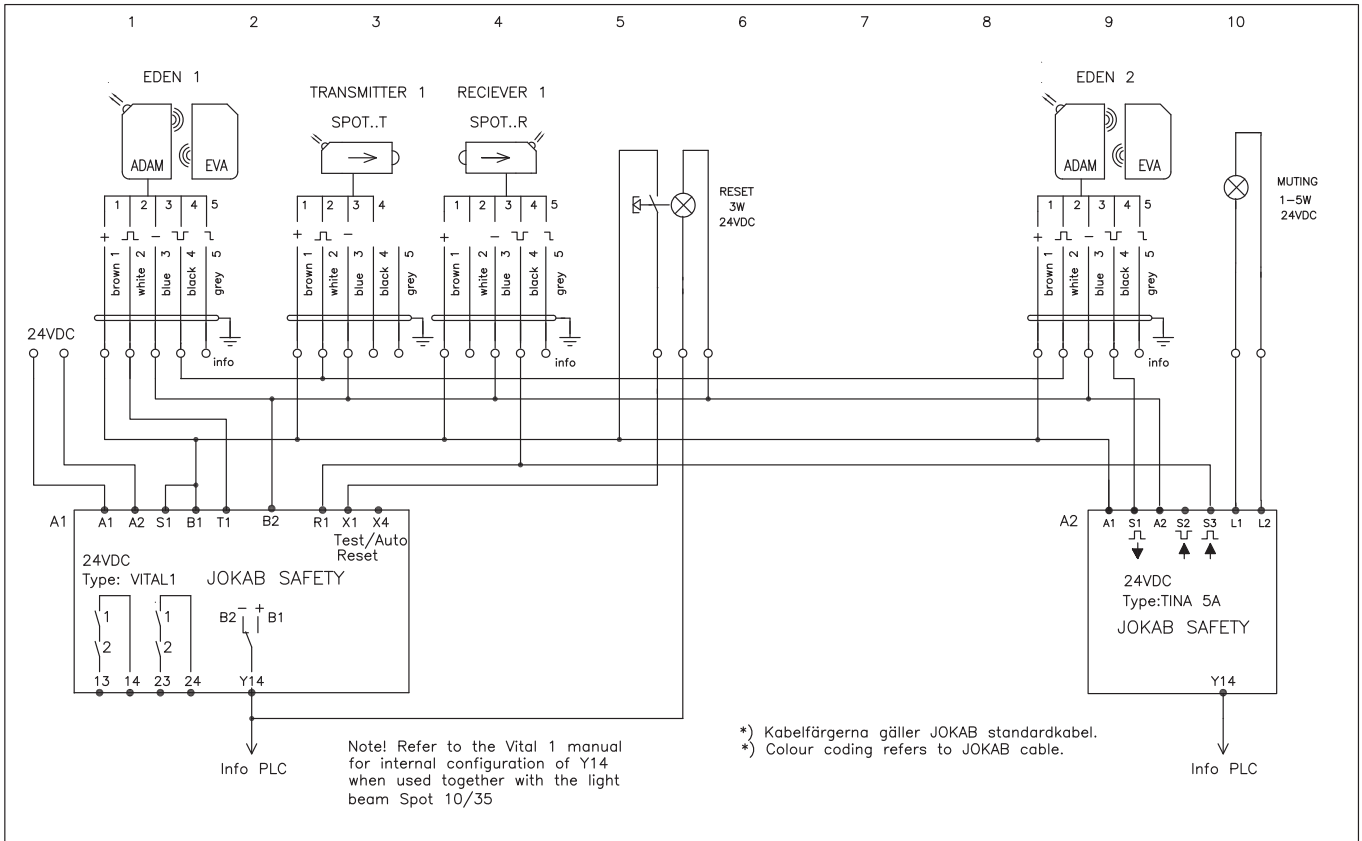

\*) Kabelfärgerna gäller JOKAB standardkabel.  
 \*) Colour coding refers to JOKAB cable.

Note! Refer to the Vital 1 manual for internal configuration of Y14 when used together with the light beam Spot 10/35

Anmärkning Remark EDEN OCH FÖRBIKOPPLAD LJUSBOM MED EDEN EDEN AND BYPASSED LIGHTBEAM WITH EDEN	Konstr Design	Godk Appr	Datum Date	Blad Sheet
	Ritad Drawn	Sidor Pages	Ritn nr Drawing no	Forts Cont
	JS		20110318	
	JS		HE3824D-01	

It is the user's responsibility to ensure that all control devices are correctly installed, cared for and operated to meet European, national and local codes/regulations. Subject to change without notice.

# HE3824E-01 Lightbeams with time-limited bypass 0.2-40 s.

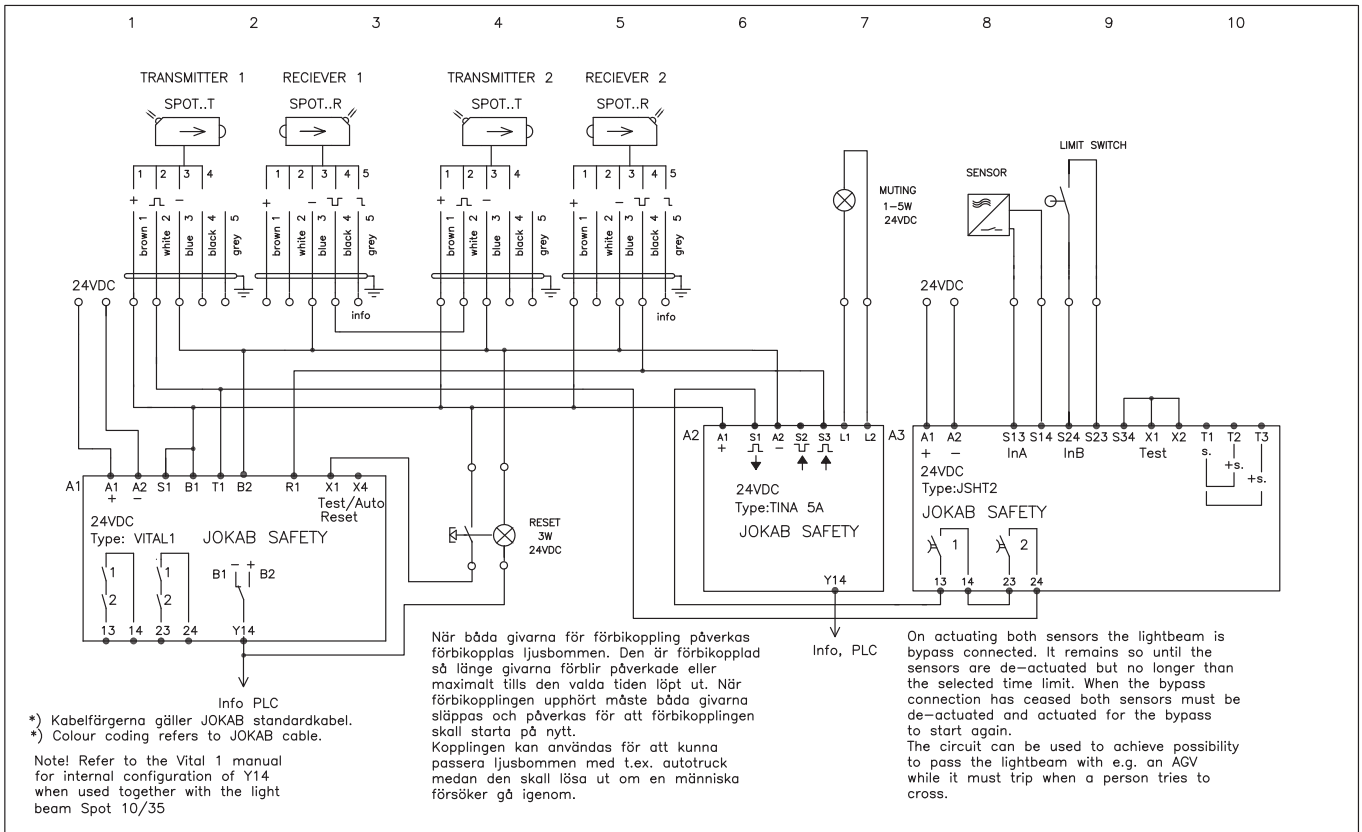

\*) Kabelfärgerna gäller JOKAB standardkabel.  
 \*) Colour coding refers to JOKAB cable.

Note! Refer to the Vital 1 manual for internal configuration of Y14 when used together with the light beam Spot 10/35

När båda givarna för förbikoppling påverkas förbikopplas ljusbommen. Den är förbikopplad så länge givarna förblir påverkade eller maximalt tills den valda tiden löpt ut. När förbikopplingen upphört måste båda givarna släppas och påverkas för att förbikopplingen skall starta på nytt. Kopplingen kan användas för att kunna passera ljusbommen med t.ex. autotruck medan den skall lösa ut om en människa försöker gå igenom.

On actuating both sensors the lightbeam is bypass connected. It remains so until the sensors are de-actuated but no longer than the selected time limit. When the bypass connection has ceased both sensors must be de-actuated and actuated for the bypass to start again. The circuit can be used to achieve possibility to pass the lightbeam with e.g. an AGV while it must trip when a person tries to cross.

Anmärkning Remark LJUSBOMMAR MED TIDSFÖRBIKOPPLING 0,2-40 SEK. LIGHTBEAMS WITH TIME-LIMITED BYPASS 0,2-40 S.	Konstr Design	Godk Appr	Datum Date	Blad Sheet
	Ritad Drawn	Sidor Pages	Ritn nr Drawing no	Forts Cont
	JS		20110318	
	JS		HE3824E-01	

It is the user's responsibility to ensure that all control devices are correctly installed, cared for and operated to meet European, national and local codes/regulations. Subject to change without notice.

# HE3824F-01 Eden and 2 bypass lightbeams with Eden

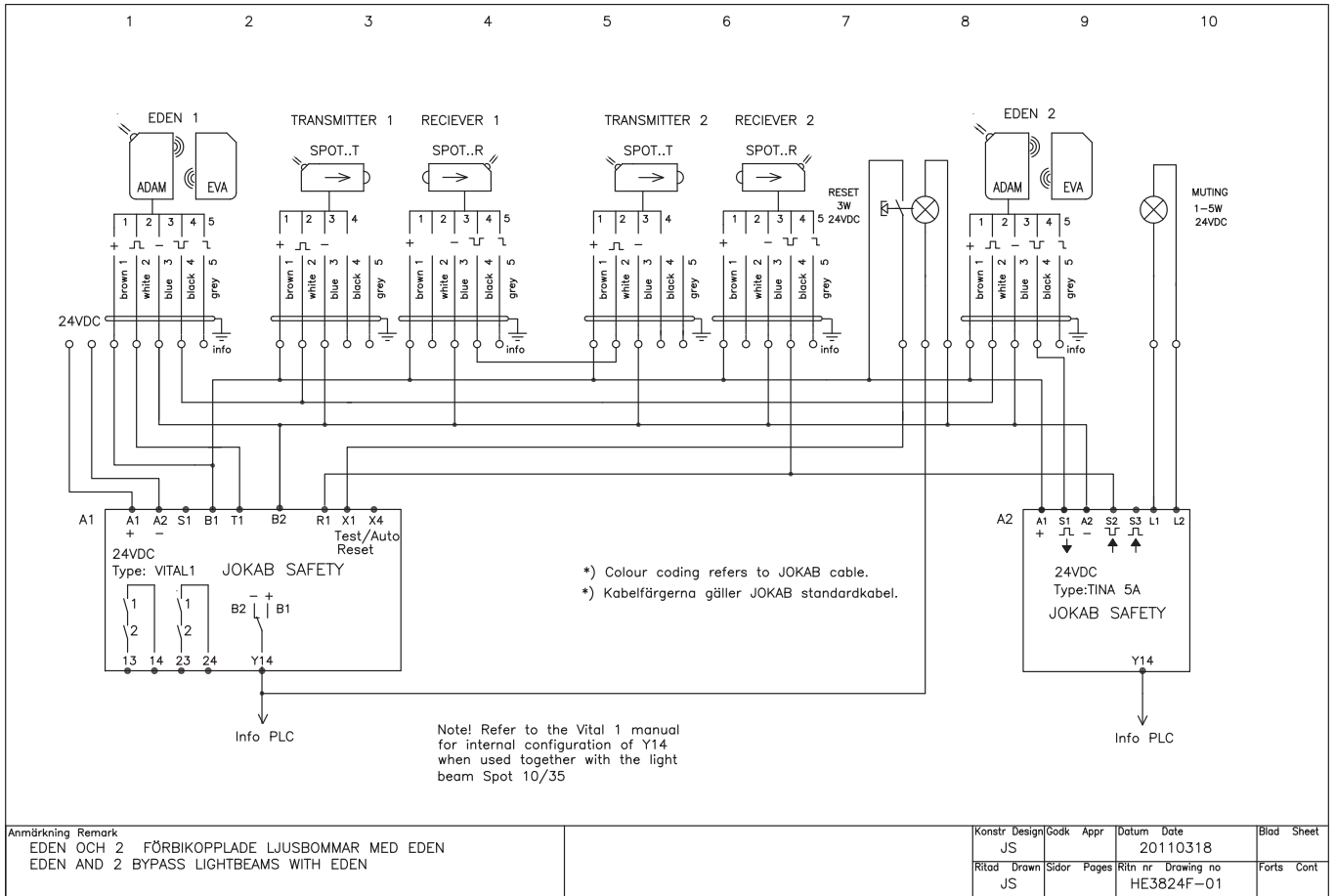

It is the user's responsibility to ensure that all control devices are correctly installed, cared for and operated to meet European, national and local codes/regulations. Subject to change without notice.

# HE3824G-01 Eden and 2 separately bypassed lightbeams

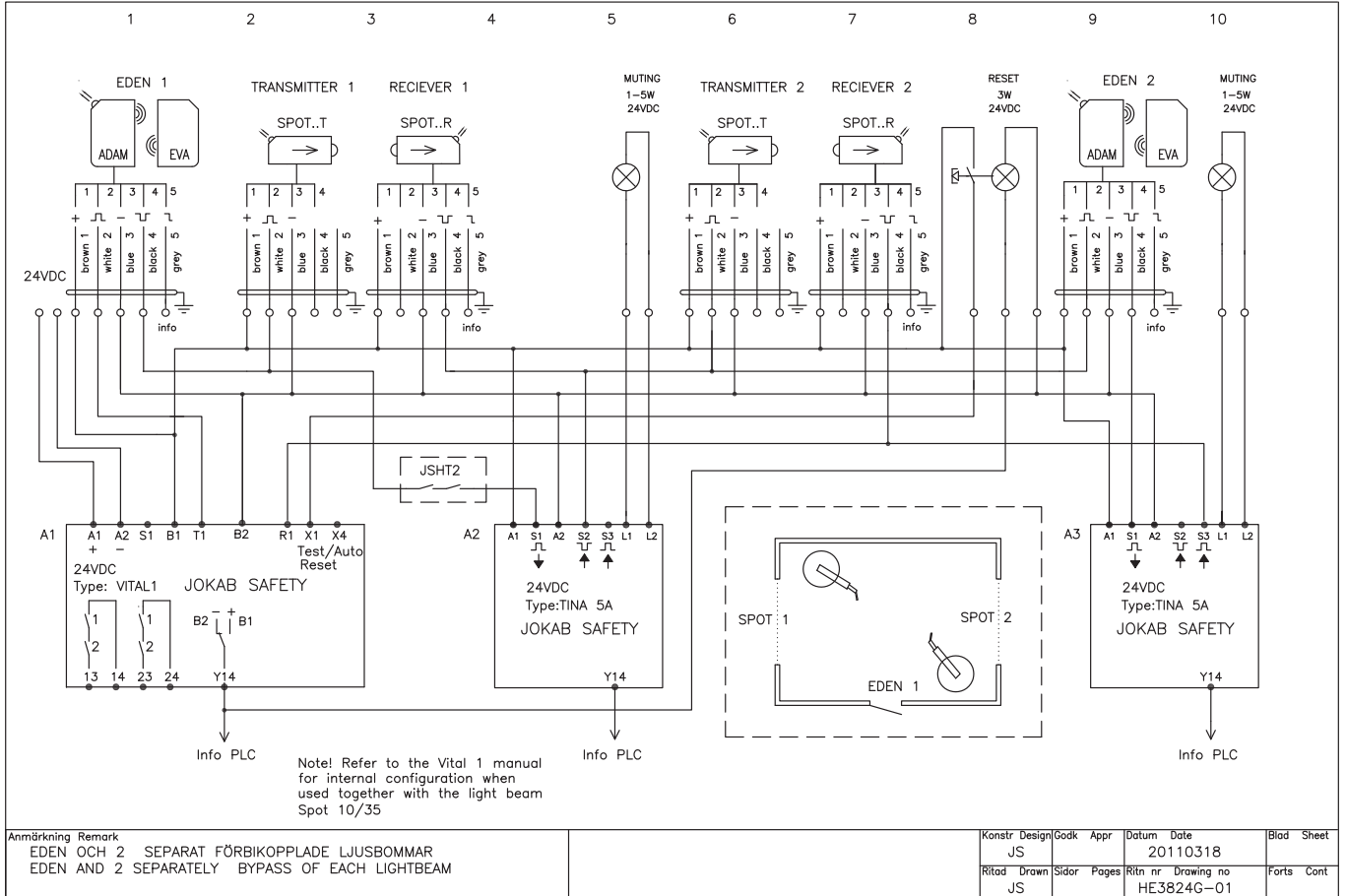

It is the user's responsibility to ensure that all control devices are correctly installed, cared for and operated to meet European, national and local codes/regulations. Subject to change without notice.

# HH3300A Vital 1 with different types of safety devices and M12-3A

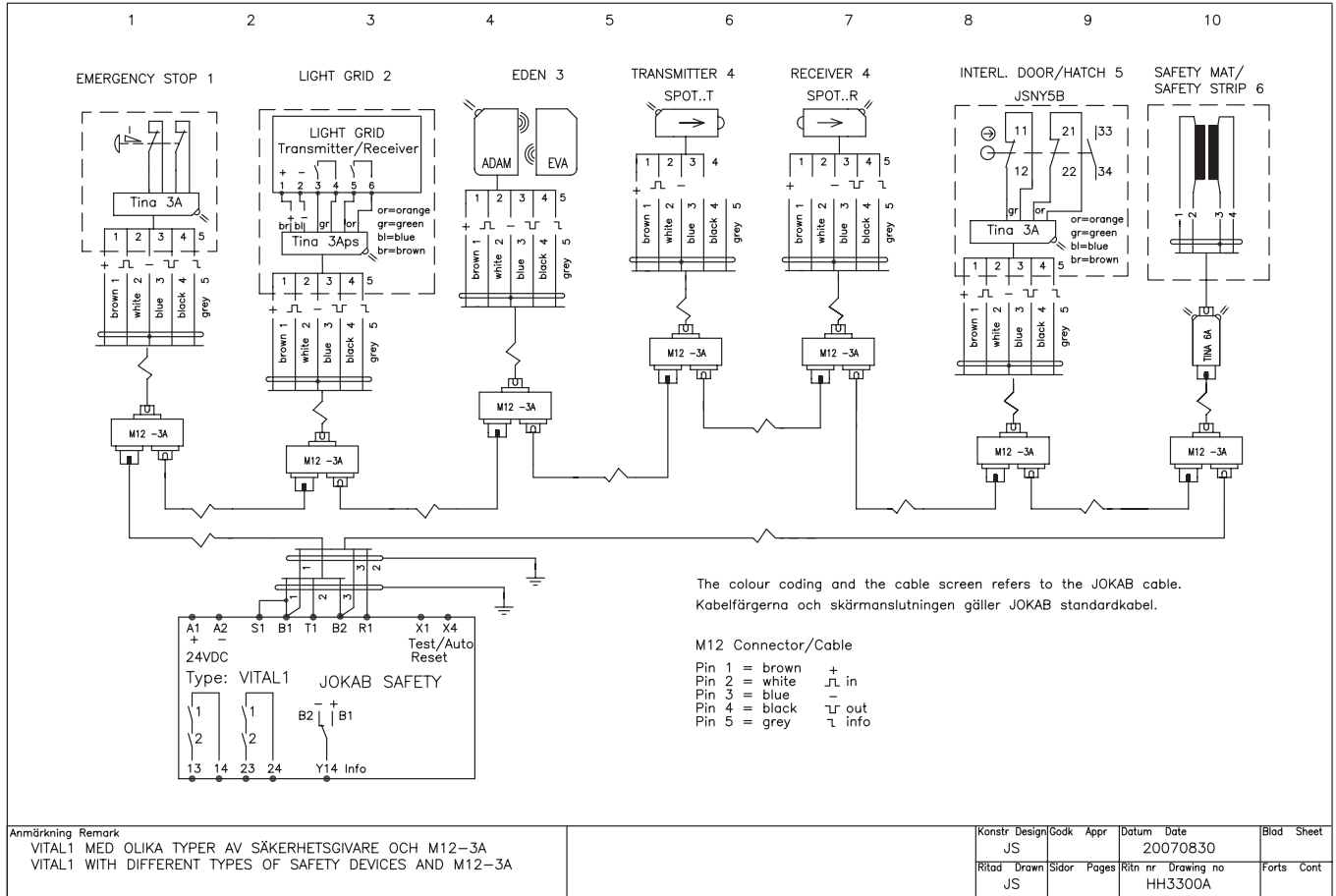

It is the user's responsibility to ensure that all control devices are correctly installed, cared for and operated to meet European, national and local codes/regulations. Subject to change without notice.

# HH3300D Vital 1 with Tina 4A and different types of safety devices

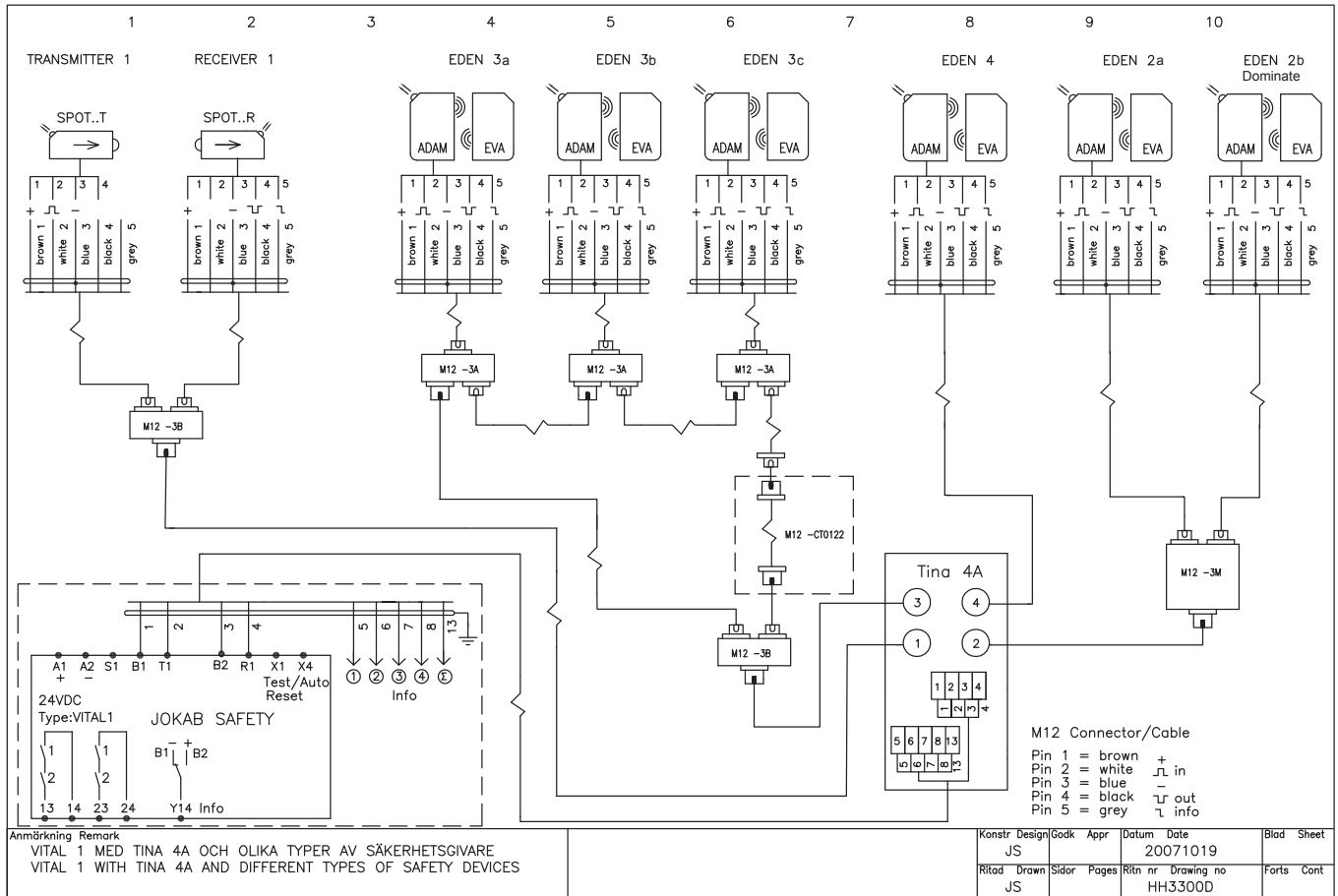

It is the user's responsibility to ensure that all control devices are correctly installed, cared for and operated to meet European, national and local codes/regulations. Subject to change without notice.

# HH3302D Vital 1 with Tina 8A and different types of safety devices

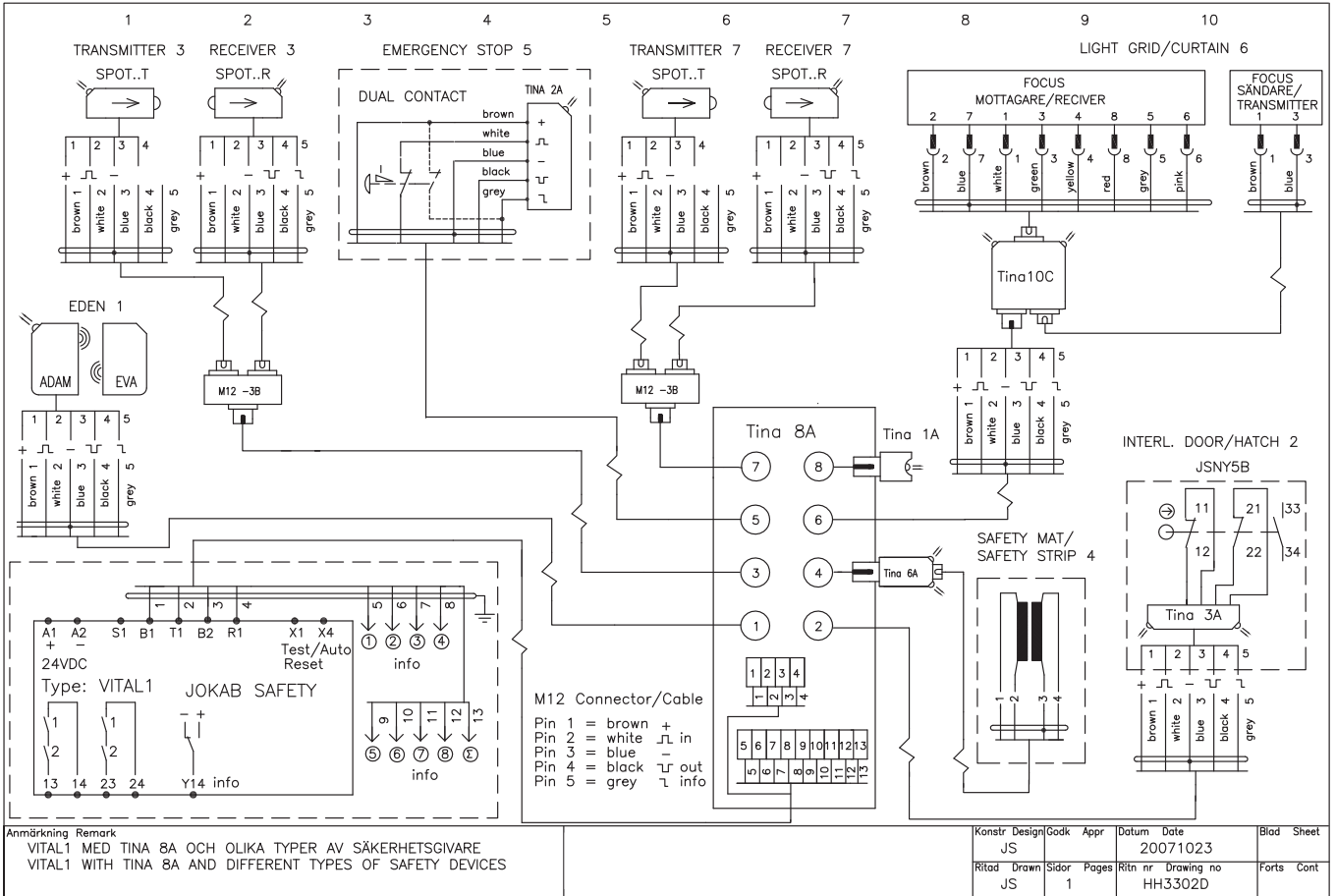

It is the user's responsibility to ensure that all control devices are correctly installed, cared for and operated to meet European, national and local codes/regulations. Subject to change without notice.

# HH3301E Connection example Vital 1

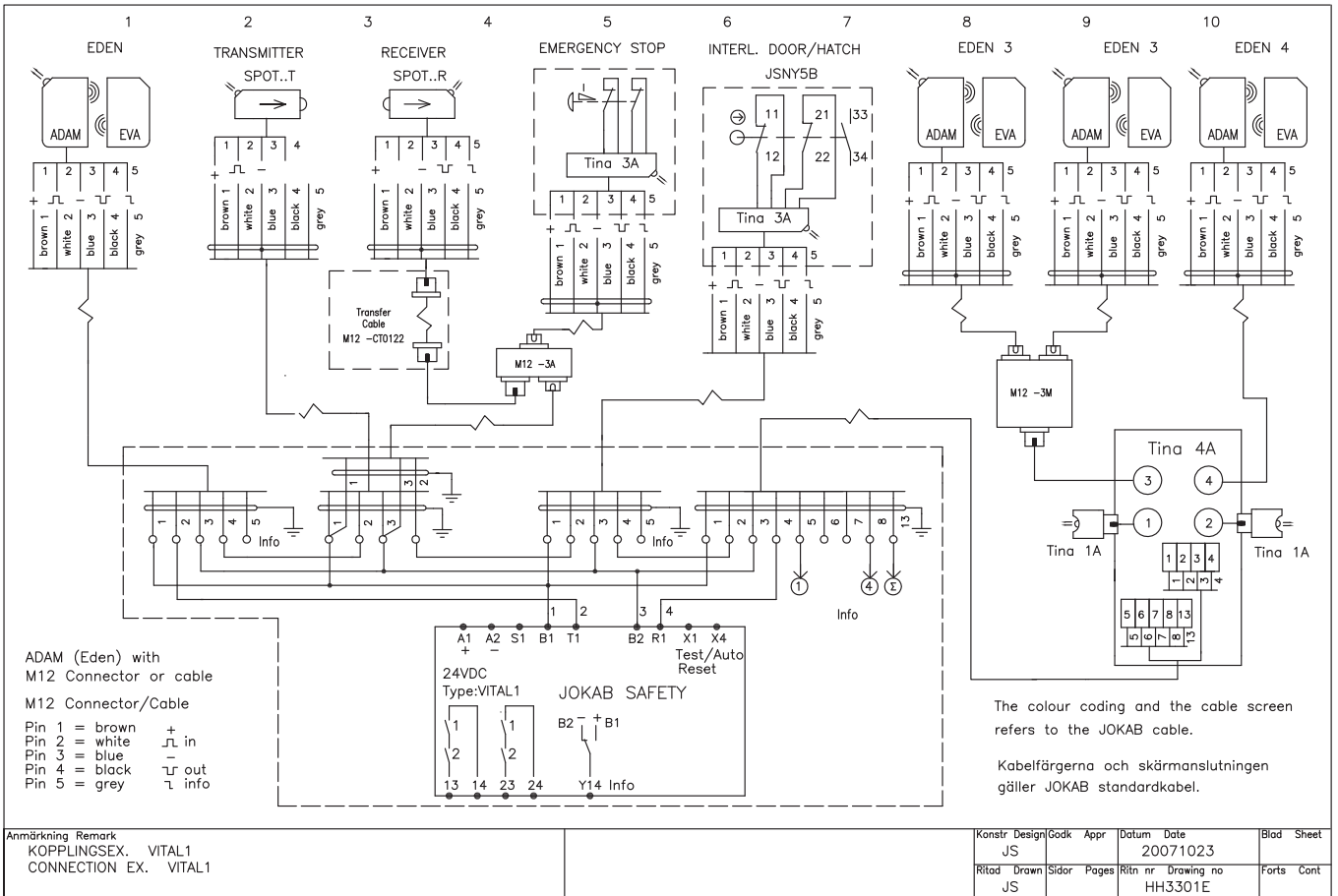

It is the user's responsibility to ensure that all control devices are correctly installed, cared for and operated to meet European, national and local codes/regulations. Subject to change without notice.

# HH3400A2 Vital 1 Solutions

CONNECTION EXAMPLE VITAL1 SOLUTIONS

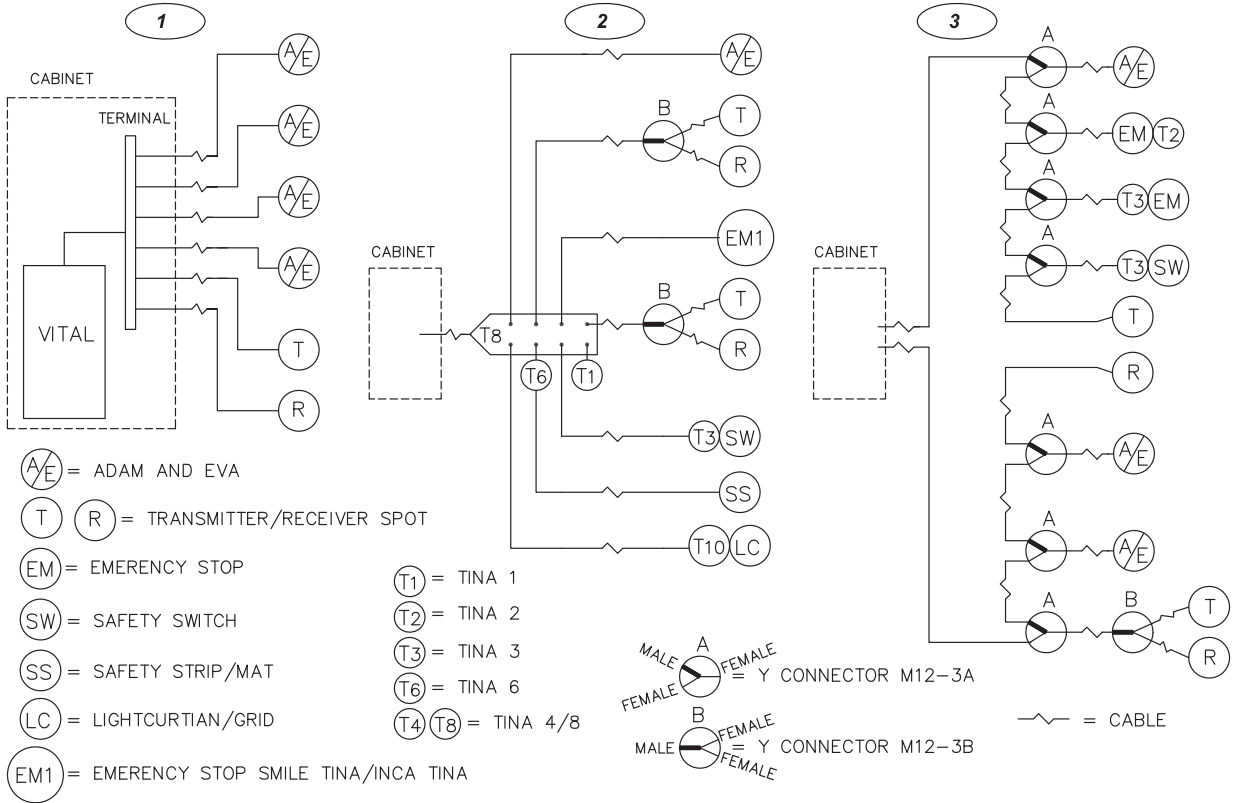

INFORMATION IS AVAILABLE VIA CABLE FROM EACH SENSOR IN EX. 1 AND 2

HH3400A2

It is the user's responsibility to ensure that all control devices are correctly installed, cared for and operated to meet European, national and local codes/regulations. Subject to change without notice.

# HB0005A Vital with Eden and Inca emergency stop, with separate reset

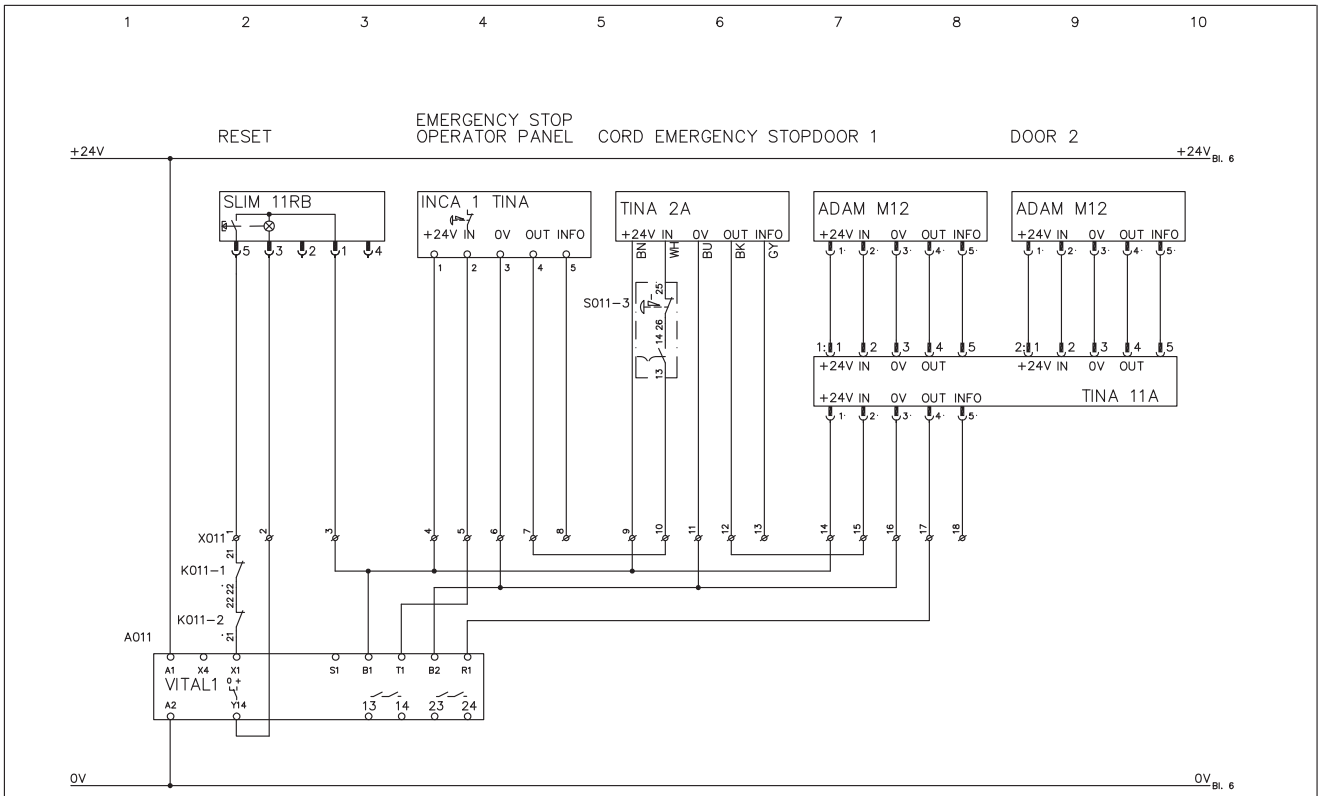

Anmärkning Remark VITAL1: DOOR GUARD AND RESET IN ONE CABLE	Konstr Design	Godk Appr	Datum Date	Blad Sheet
	Ritad Drawn	Sidor Pages	Ritn nr Drawing no	Forts Cont
	JS		20080402	
	JS		HB0005A	

It is the user's responsibility to ensure that all control devices are correctly installed, cared for and operated to meet European, national and local codes/regulations. Subject to change without notice.



# HB0006A Vital with 4 Eden units + Reset via M12-3E and Tina 4A

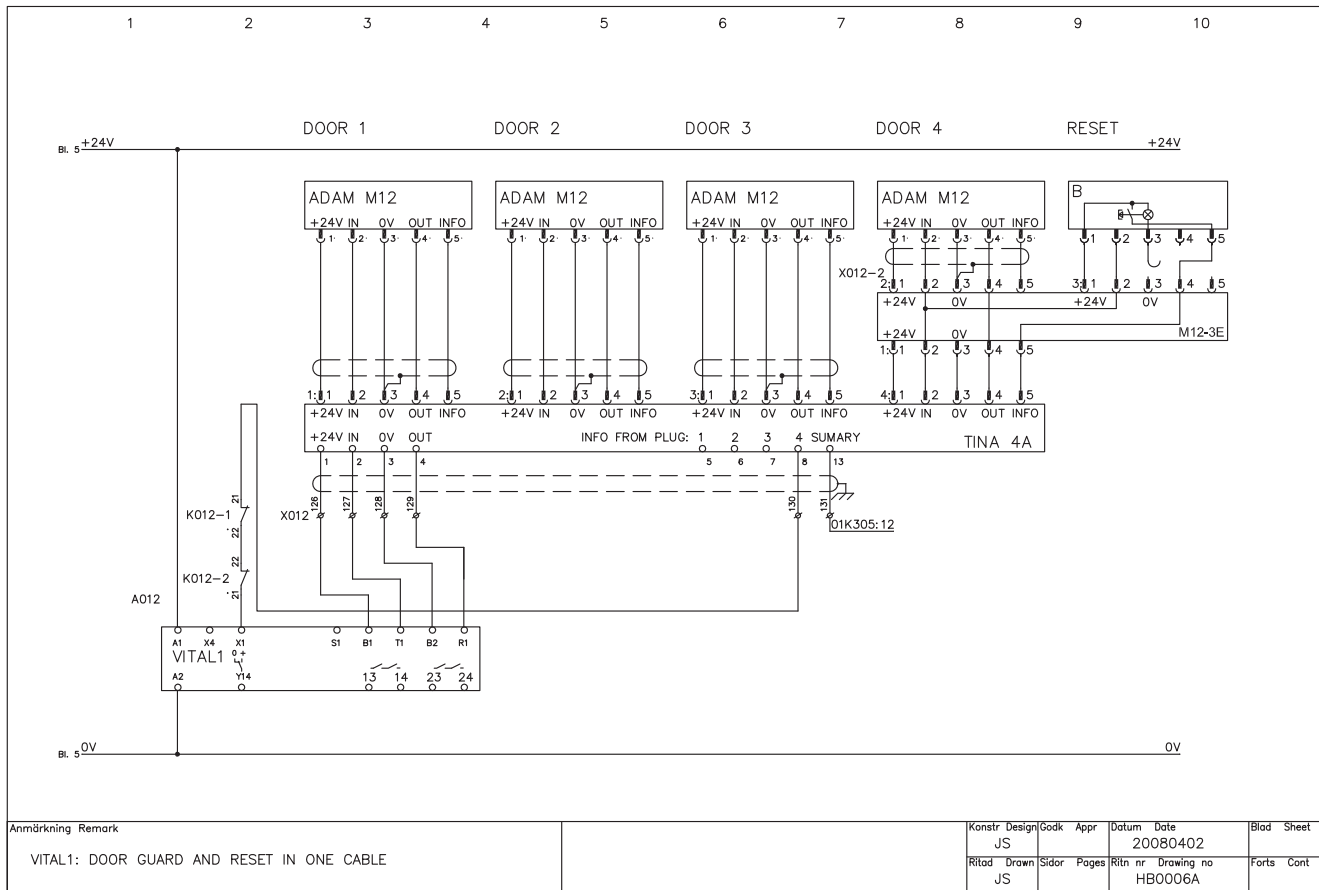

It is the user's responsibility to ensure that all control devices are correctly installed, cared for and operated to meet European, national and local codes/regulations. Subject to change without notice.

# HB0007A Vital with two Dalton units via Tina 12A

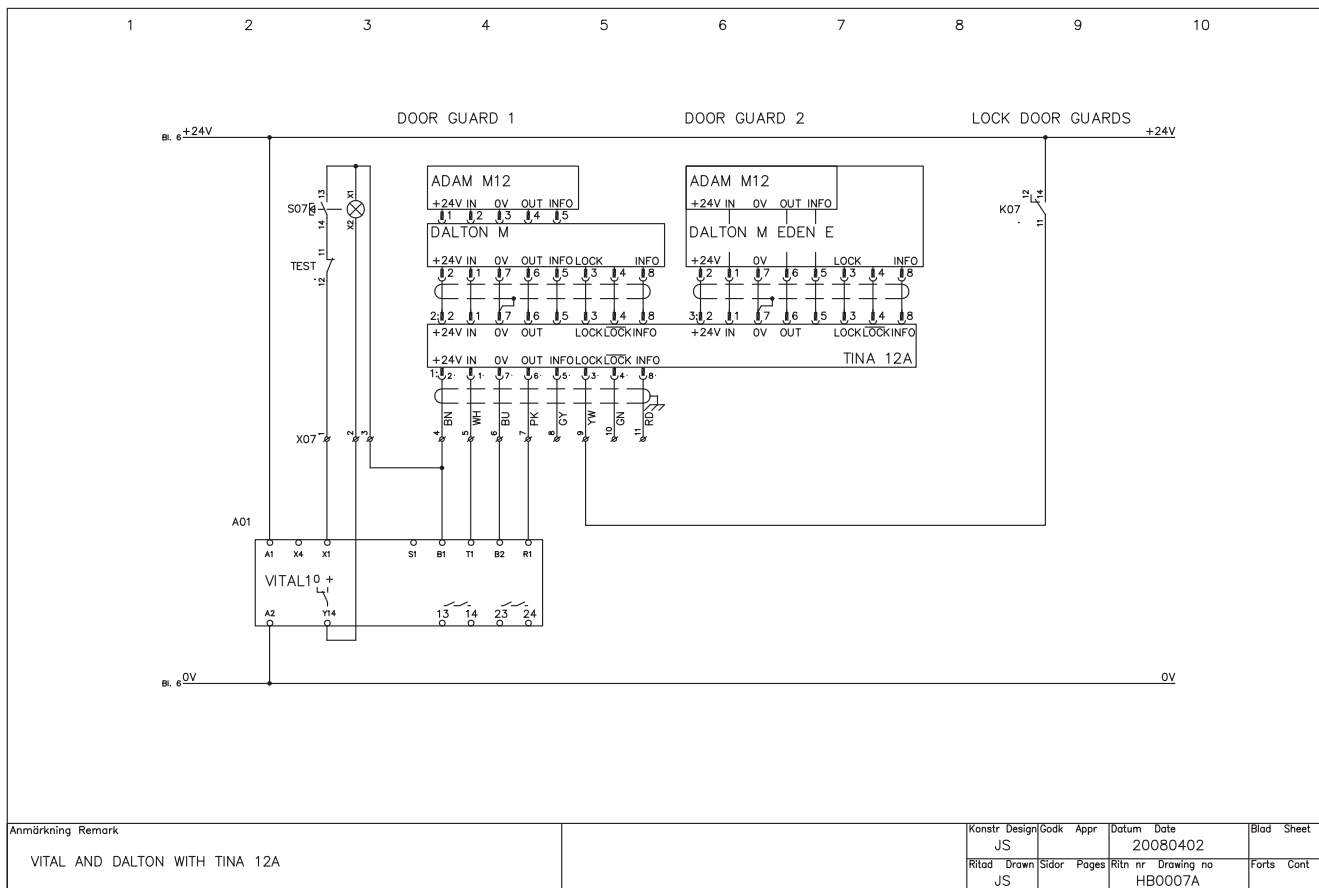

It is the user's responsibility to ensure that all control devices are correctly installed, cared for and operated to meet European, national and local codes/regulations. Subject to change without notice.

# HB0001A Pluto with Smile emergency stop unit + Reset via M12-3E and Adam via Tina 4A

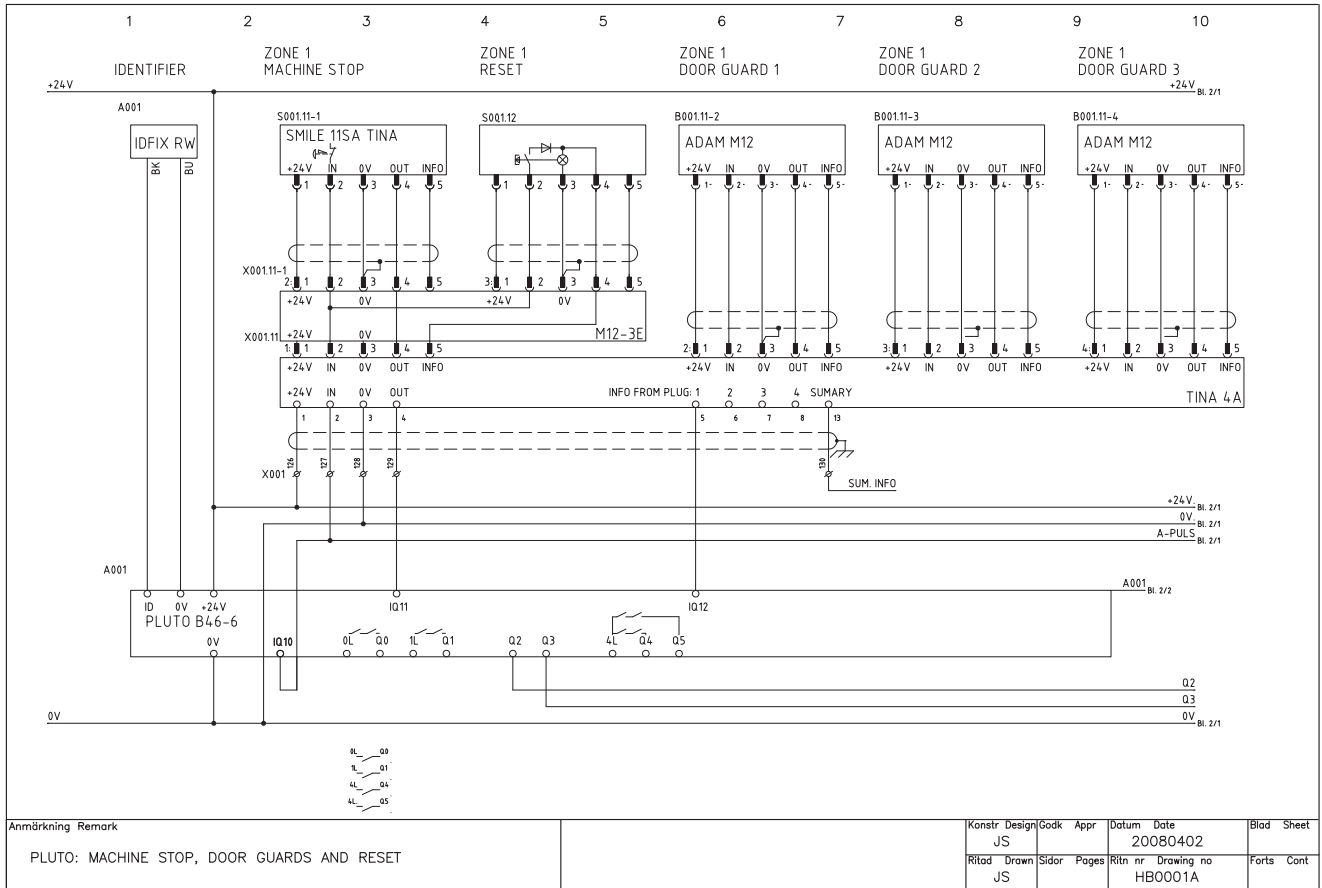

It is the user's responsibility to ensure that all control devices are correctly installed, cared for and operated to meet European, national and local codes/regulations. Subject to change without notice.

# HB0002A Pluto with five Eden units, for two zones via M12-3E and Tina 4A

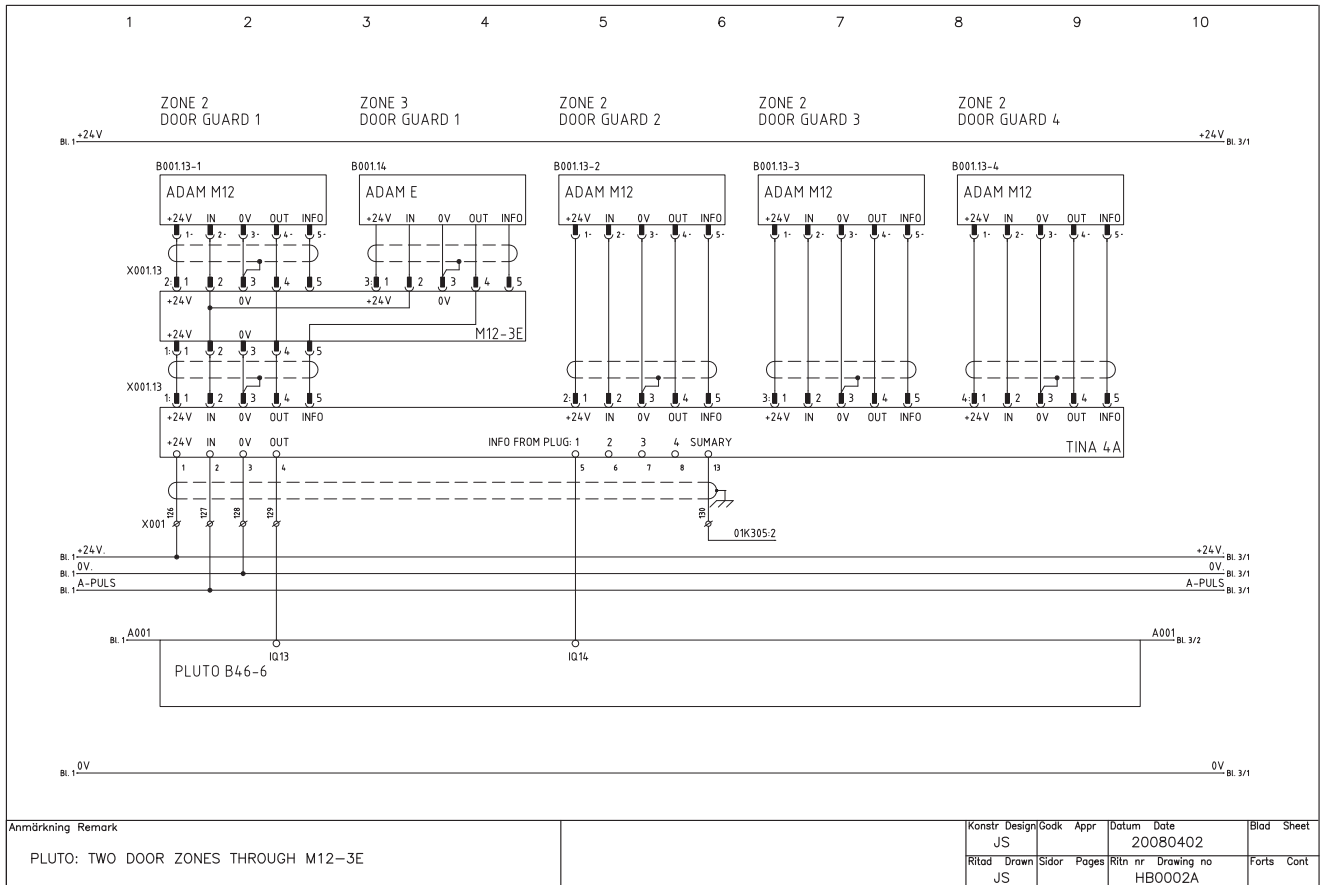

It is the user's responsibility to ensure that all control devices are correctly installed, cared for and operated to meet European, national and local codes/regulations. Subject to change without notice.

# HB0003A Pluto with Smile and Inca emergency stop units, via Tina 11A and Tina 4A

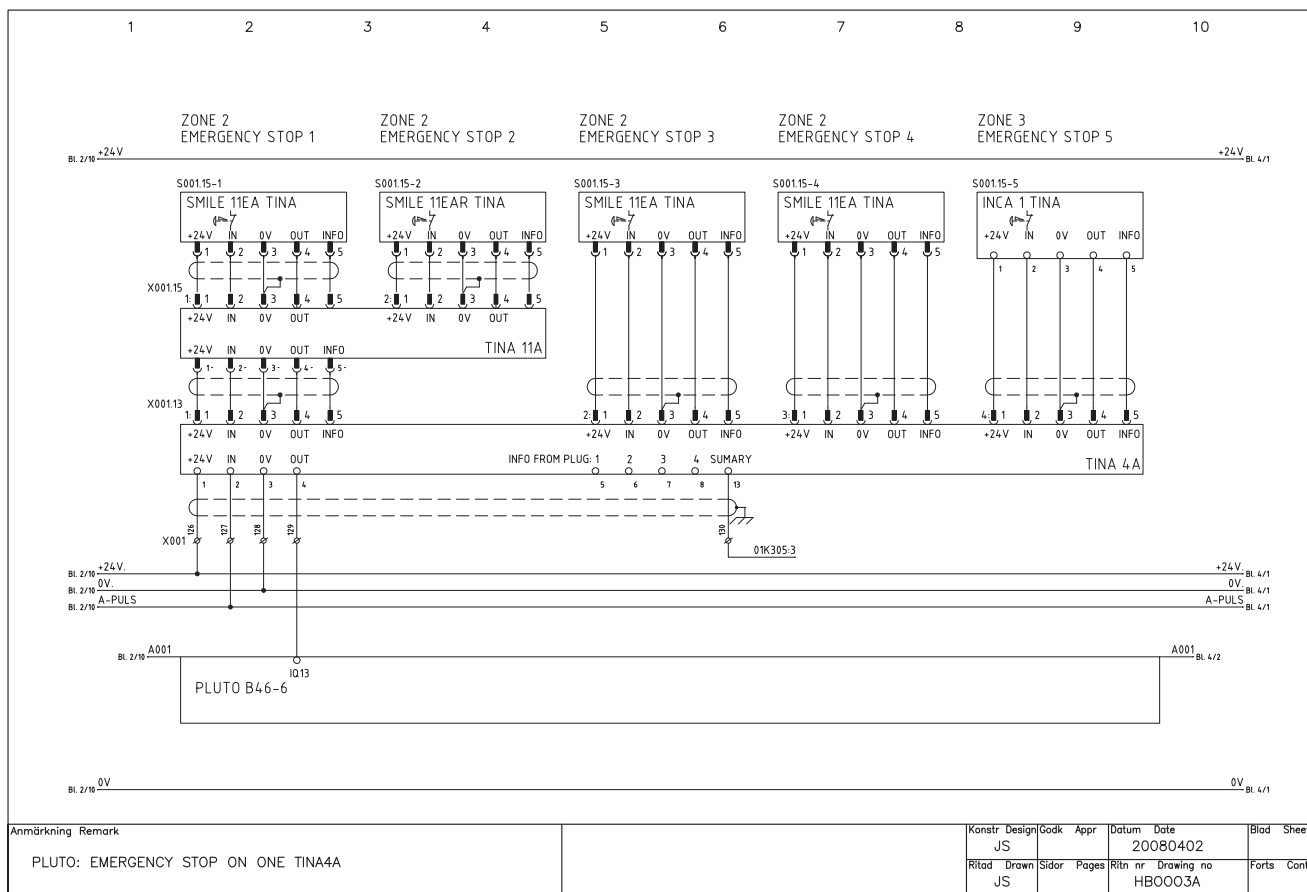

It is the user's responsibility to ensure that all control devices are correctly installed, cared for and operated to meet European, national and local codes/regulations. Subject to change without notice.

# HB0004A Pluto with different zones for Eden + Reset and two Eden units +via M12-3E

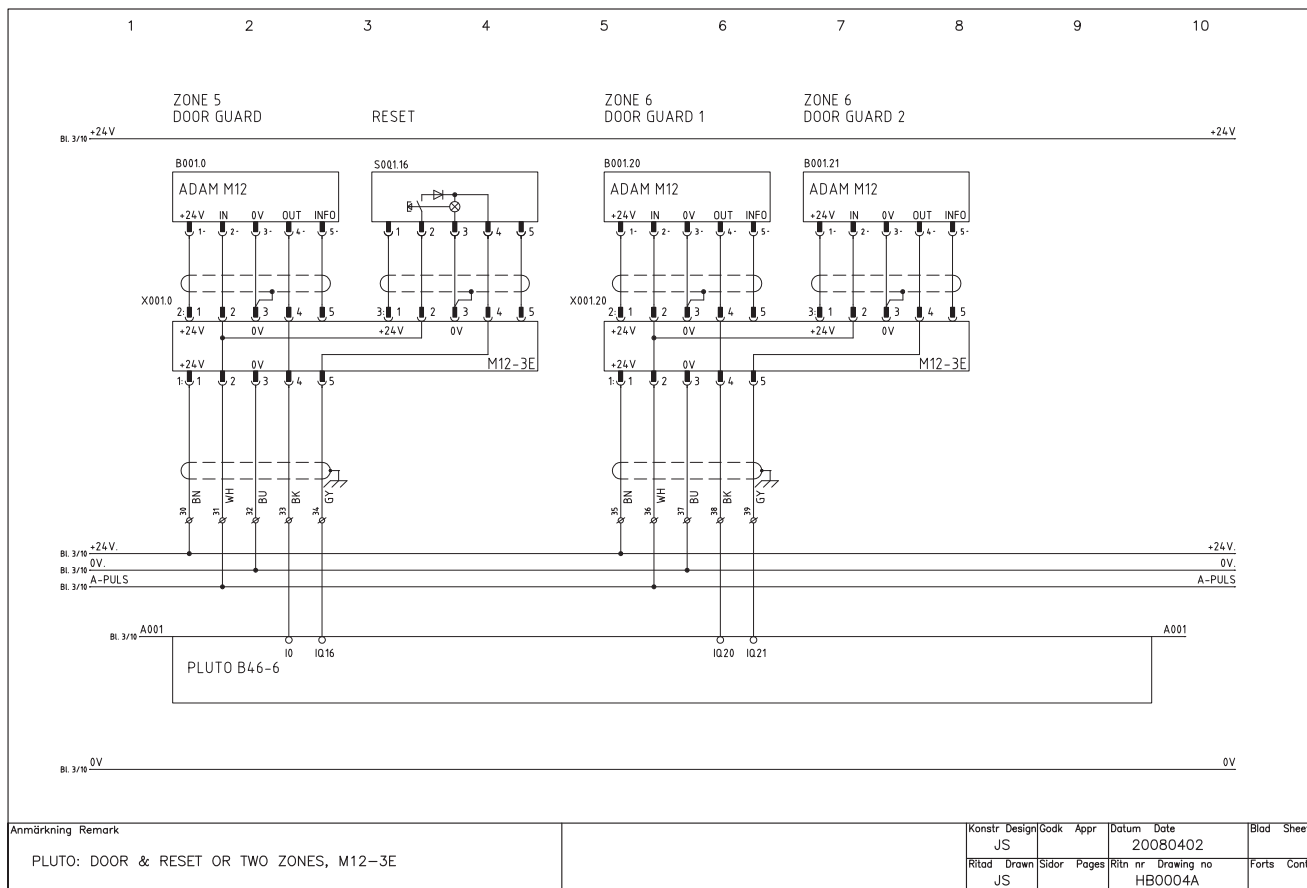

It is the user's responsibility to ensure that all control devices are correctly installed, cared for and operated to meet European, national and local codes/regulations. Subject to change without notice.

# HH3301D Connection example – Vital 1 and Tina 8A with different safety device types

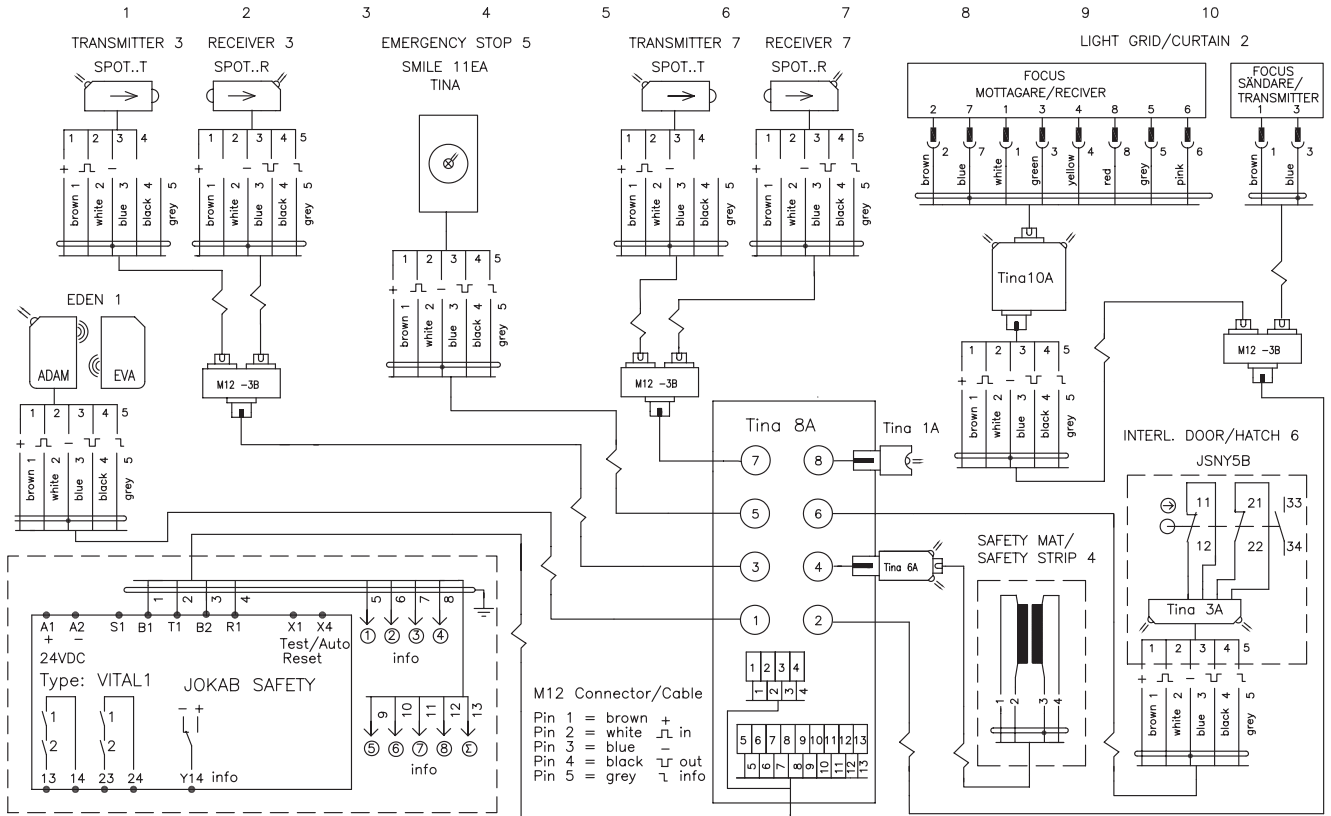

It is the user's responsibility to ensure that all control devices are correctly installed, cared for and operated to meet European, national and local codes/regulations. Subject to change without notice.

# HH3300F Vital 1 with Tina 8B Profibus and different types of safety devices

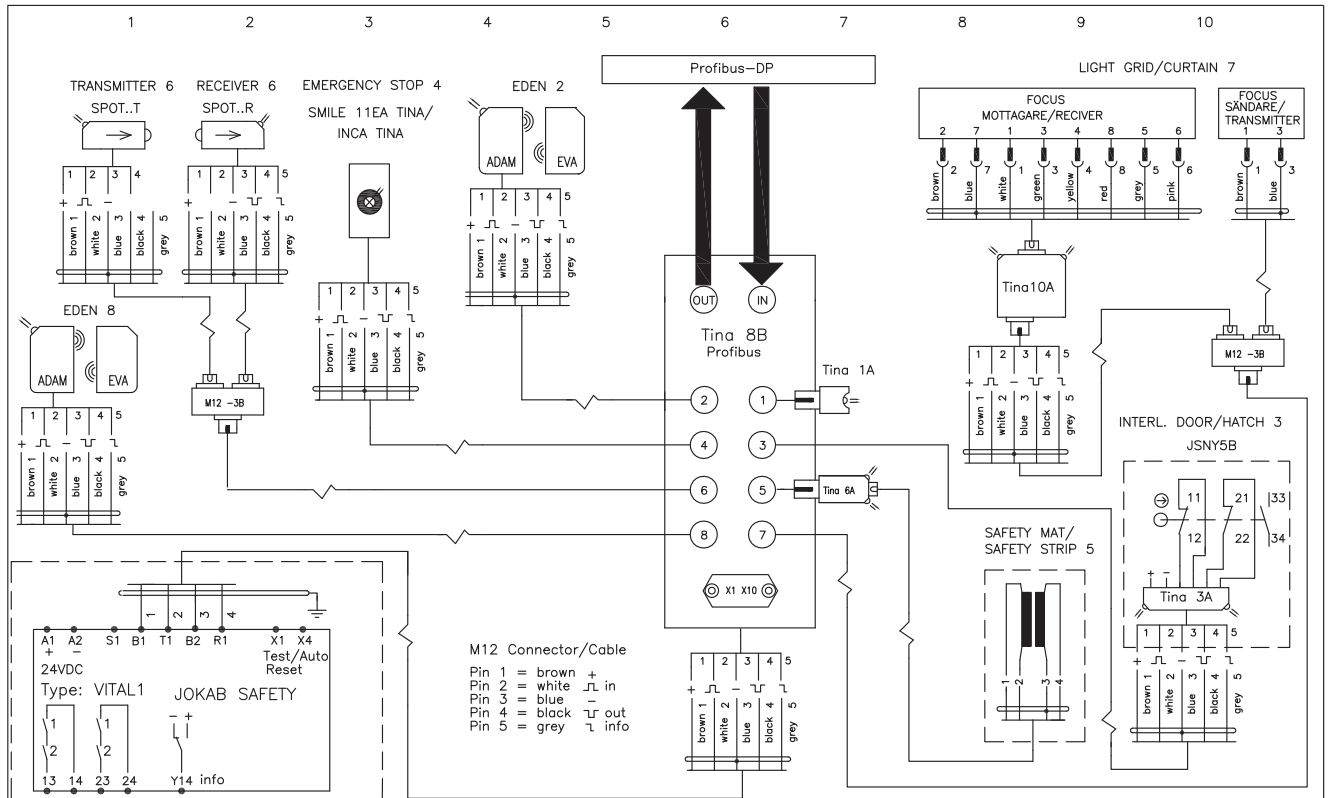

Anmärkning Remark VITAL1 MED TINA 8B PROFIBUS OCH OLIKA TYPER AV SÄKERHETSGIVARE VITAL1 WITH TINA 8B PROFIBUS AND DIFFERENT TYPES OF SAFETY DEVICES	Konstr Design	Code	Appr	Datum Date	Blad Sheet
	Ritad Drawn	Sidor Pages	Ritn nr Drawing no	20071025	Forts Cont
	JS	1	JS	HH3300F	

It is the user's responsibility to ensure that all control devices are correctly installed, cared for and operated to meet European, national and local codes/regulations. Subject to change without notice.



# Safety Relays

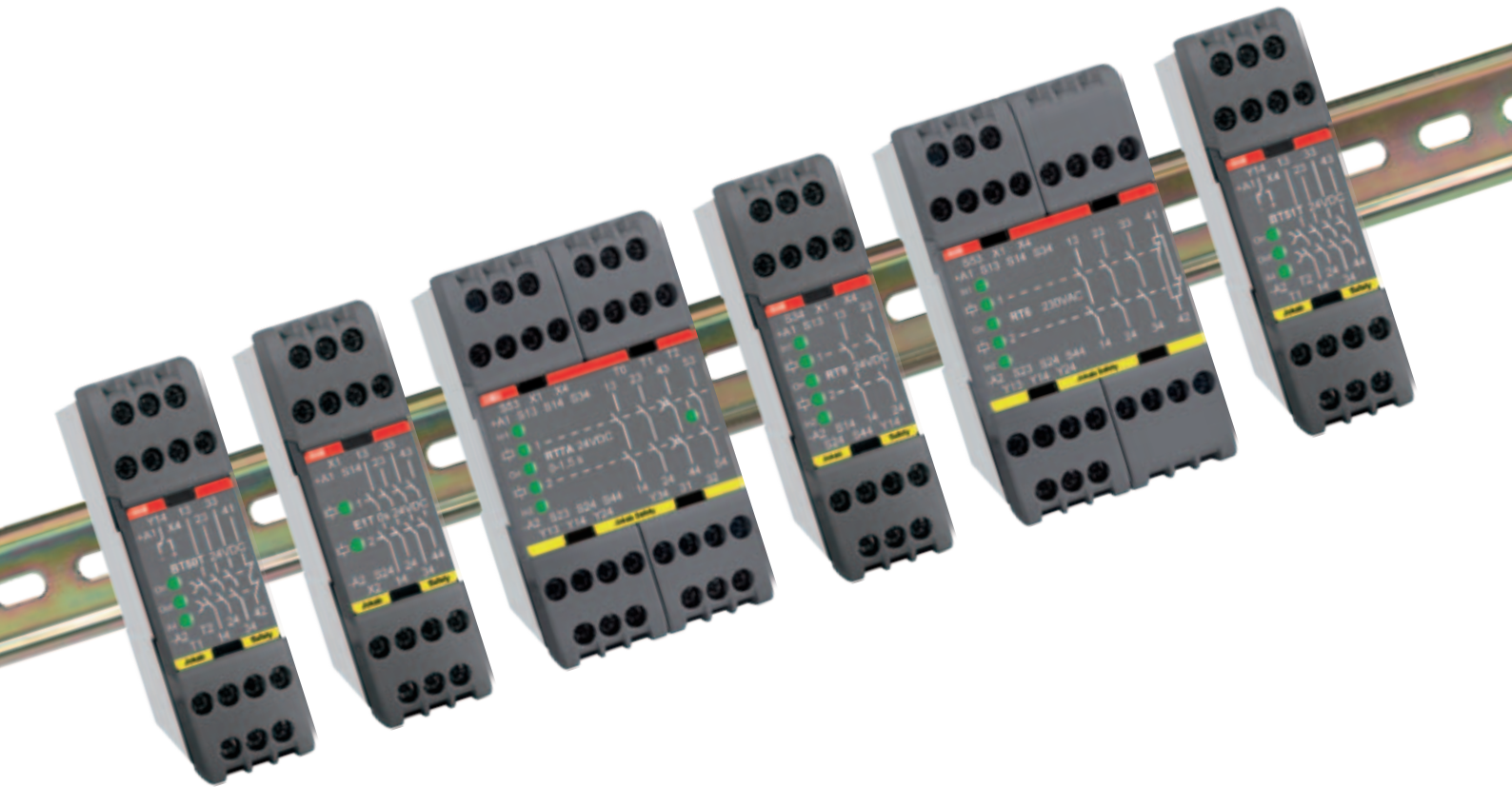



<b>Contents</b>	<b>Page</b>
<i>Why should you use Safety relays?</i> _____	<b>6:2</b>
<i>The smallest and most flexible Safety relays on the market</i> _____	<b>6:3</b>
<i>Safety relay summary</i> _____	<b>6:4</b>
<b>Safety relay - RT - series</b>	
• RT6 _____	<b>6:6</b>
• RT7 _____	<b>6:10</b>
• RT9 _____	<b>6:14</b>
• JSBRT11 _____	<b>6:18</b>
<b>Safety relay - JSB - series</b>	
• JSBR4 _____	<b>6:20</b>
• JSBT4 _____	<b>6:22</b>
• BT50(T) _____	<b>6:24</b>
• BT51(T) _____	<b>6:26</b>
• JSBT5(T) _____	<b>6:28</b>
<b>Safety timers</b>	
• JSHT1A/B _____	<b>6:30</b>
• JSHT2A/B/C _____	<b>6:32</b>
<b>Expansion relays</b>	
• E1T _____	<b>6:34</b>
• JSR1T _____	<b>6:36</b>
• JSR2A _____	<b>6:38</b>
• JSR3T _____	<b>6:40</b>
<b>Connection examples</b> _____	<b>6:42</b>

Descriptions and examples in this book show how the products work and can be used. This does not mean that they can meet the requirements for all types of machines and processes. The purchaser/user is responsible for ensuring that the product is installed and used in accordance with the applicable regulations and standards. We reserve the right to make changes in products and product sheets without previous notice. For the latest updates, refer to [www.abb.com/lowvoltage](http://www.abb.com/lowvoltage). 2011.

# Why should you use safety relays?

## - to meet existing safety standards!

"A fault in the control circuit logic, or failure of or damage to the control circuit must not lead to dangerous situations". This is the requirement in the EU's Machinery Directive 98/37/EC under the heading 1.2.7. "Failure of the control circuit". The directive implies that no person should be put at risk if for example, a relay sticks or if a transistor or two electrical conductors short-circuit.

A safety relay will fulfill these requirements. A safety relay

has, for example, inputs that are checked for short-circuits and dual redundant circuits that are checked at each operation. This can be compared to the dual brake circuits in a car. If one of the circuits is faulty the other will stop the car. In a safety relay there is an additional function which only allows a machine to start if both circuits are ok.

The standard for safety related parts of the control system describes various safety categories depending on the level of risk and application. One single universal relay with selectable safety categories solves this.

## - to supervise safety devices!



Light beams

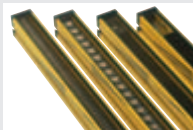

Light curtains/  
Light grids



Three position  
devices



Safety  
interlock  
switches

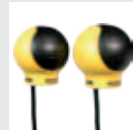

Two-hand  
devices



Emergency  
stop

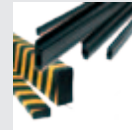

Safety strips  
& Bumpers

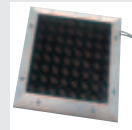

Safety mats

## - for safe stops and reliable restarts!



**Dual stop signals when the gate is opened.**

Entering or putting a hand or limb into a hazardous area must cause all machinery that can cause personal injury to stop safely. Many serious accidents occur when machinery is believed to have stopped but is in fact only pausing in its program sequence. The safety relay monitors the gate interlock switch and cables and gives dual stop signals.



**Supervised reset when there can be a person within the risk area.**

To make sure that nobody is within the restricted area when activating the reset button. A supervised reset button must be pressed and released before a reset can occur. Many serious accidents have been caused by an unintentional and unsupervised reset.

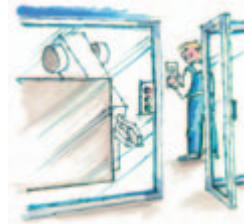

**Timed reset when you cannot see the entire risk area.**

Sometimes a double reset function is necessary to make sure that no one is left behind in the risk area. First, after ensuring no other person is inside the hazardous area, the pre-reset button must be activated, followed by the reset button outside the risk area within an acceptable time period e.g 10 seconds. A safety timer and a safety relay can provide this function.



**Automatic reset for small hatches.**

Where body entry is not possible through a hatch, the safety circuit can be automatically reset.

The safety relays are reset immediately when the hatch interlock switch contacts are closed.

# The most flexible safety relays on the market!

We have the most flexible safety relays on the market. Our first universal relay was developed in 1988.

Nowadays, the flexibility is even greater and size has been reduced by 85 %.

A universal relay is a safety relay with various input options for various safety devices and risk levels.

Internally, the safety relay is of the highest safety level (PL e according to EN ISO 13849-1). A machine supplier can therefore, with one single safety relay, select the input configuration that best suits their customers' safety requirements. In addition, our safety relays have detachable connector blocks for ease of replacement and testing. As our universal relays incorporate all input options, they are

compatible with all our previous safety relays as well as with other manufacturers' products.

Is a universal relay expensive? No, our latest patented construction is extremely simple and the number of major components is less compared to our previous universal relays. This means that the safety relays are even more reliable than before.

We also have a great deal of experience from safety solutions in our own system developments. It would be our pleasure to share these experiences with you! Please see the complete safety solutions in the section "Connection examples". Please do not hesitate to contact us if you should require any other safety solutions.

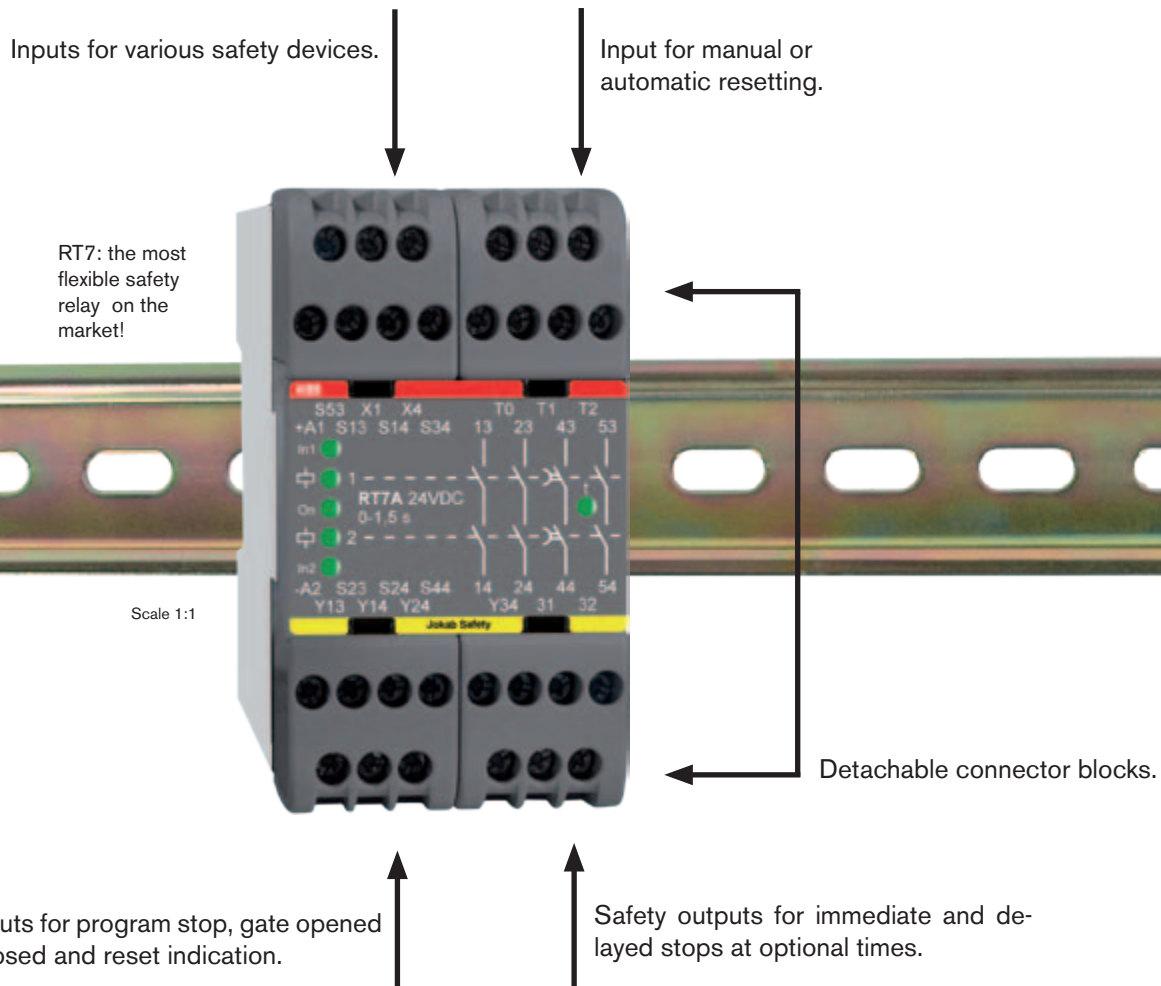

## Some of the advantages with ABB Jokab Safety's safety relays:

- Universal relays
- Excellent reliability
- Approved in Europe, USA, Canada
- Supervised reset
- Time reset
- Small and compact
- Detachable connector blocks
- Low power consumption
- Permits the use of long emergency stop cables
- EX compatibility
- Functions set by external hardwired links
- LED indication for inputs and outputs
- Powerful switching capacity

# summary SAFETY RELAYS

## - Which safety relay should you choose?

First of all, we would recommend the selection of one of our latest universal relays in the RT-series. These are both practical and cost effective.

To facilitate the choice of safety relay or combinations of safety relays, please see:

- the table below dividing the safety relays into application fields
- the table on the opposite page showing possible input and output options
- the relevant data sheet giving comprehensive information about each specific safety relay
- the circuit diagram for various applications in the section "Connection examples".

**Note:** All earlier types of relays that can now be replaced by those in this manual are still kept as stock items and can be supplied upon request.

## Application fields

	Safety relays					Safety-timers		Expansion relays						
	RT6	RT7	RT9	JSBRT11	JSBR4	JSBT4	JSBT51, BT50T, BT51T	JSBT5, BT50, BT51	JSH1A/B	JSH2A/B/C	E1T	JSRTT	JSR2A	JSR3T
Interlocking switch/Gate/Hatch	•	•	•	•	•	•	•	•						
Light curtains	•	•	•	•										
Light beams	•	•	•	•										
Safety mats	•	•	•		•	•								
Contact strips	•	•	•		•	•								
Two-hand control device					•									
Emergency stop	•	•	•	•	•	•	•	•						
Hold to run/enabling device	•	•	•	•	•	•				•				
Foot control device	•	•	•	•	•	•				•				
Area supervision	•	•	•	•	•	•								
Time resetting									•					
Time bypassing									•	•				
Inching										•				
Output expansion	•	•	•	•		•	•	•			•	•	•	
Delayed output		•					•				•	•		•

## Input alternatives (see also technical data on the next page)

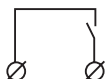

**Single-channel, 1 NO from +24 V Category 1, up to PL c**  
The input must be closed before the outputs can be activated. A stop signal is given when the input is opened.

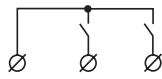

**Two-channel, 2 NO from +24 V Category 3, up to PL d**  
Both the inputs must be closed before the outputs can be activated. A stop signal is given if one or both of the inputs are opened. Both the inputs must be opened and reclosed before the outputs can be reactivated. A short-circuit between the inputs is not monitored by the safety relay. Category 4 can only be achieved if a safety device with short circuit monitored outputs is connected.

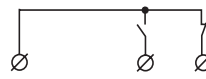

**Two-channel, 1 NO & 1 NC from +24V Category 4, up to PL e**  
One input must be closed and one must be opened before the outputs can be activated. A stop signal is given if one or both of the inputs change position or if the inputs short-circuit. Both inputs must be put into their initial position before the outputs can be reactivated.

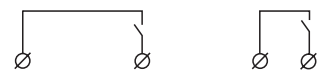

**Two-channel, 1 NO from 0 V & Category 4, up to PL e**  
Both the inputs must be closed before the outputs can be activated. A stop signal is given if one or both of the inputs are opened. Both the inputs must be opened and reclosed before the outputs can be reactivated. A Stop signal is given if there is a short-circuit between the inputs.

## Technical data

	Safety relays										Safety-timers		Expansion relays				
	RT6	RT7	RT9	JSBRT11	JSBR4	JSBT4	JSBT5T	BT50T	BT51T	BT50 (JSBT5)	BT51	JSHT1A/B	JSHT2A/B/C	EIT	JSRT1	JSR2A	JSR3T
<b>Safety category</b>	1-4	1-4	1-4	1-4	4	4	1-4°	1-4°	1-4°	1-4°	1-4°	1-4	1-4	1-4	1-4	1-4	1-4
<b>Safety input</b>																	
Single-channel, 1 NO from +24 V	•	•	•	•			•	•	•	•	•	•	•	•	•	•	•
Two-channel, 2 NO from +24 V	•	•	•	•													
Two-channel, 1 NO & 1 NC from +24 V	•	•	•	•													
Two-channel, 1 NO from 0 V & 1 NO from + 24 V	•	•	•	•	•	•						•	•	•	•	•	•
Contact strips/Safety mats	•	•	•		•	•											
<b>Reset &amp; test input</b>																	
Monitored manual	•	•	•	•	•												
Automatic/Unmonitored manual	•	•	•	•		•	•	•	•	•	•						
Testing of contactors, relays, valves, etc.	•	•	•	•	•	•	•	•	•	•	•	•	•				
<b>Output</b>																	
NO	3	2	2	7	3	3				3	4			4*	4*	4	
NO delayed		2					3 <sup>‡</sup>	3	4					4*	4*		2 <sup>‡</sup>
NO impulse outputs												2 <sup>‡</sup>	2 <sup>‡</sup>				
NC	1	1		2	1	1				1					1*	1	
NC delayed							1 <sup>†</sup>	1							1*		
Info. output	2	3	1					1	1								
<b>Switching capacity (resistive load)</b>																	
6A/250VAC/1500VA/150W	4	3	2	9	4	4	4	4 <sup>‡</sup>	4 <sup>‡</sup>	4	4			4	5		
4A/250VAC/1000VA/100W												2 <sup>‡</sup>	2 <sup>‡</sup>				2 <sup>‡</sup>
6A/250VAC/1380VA/138W		2 <sup>‡</sup>															
10A/250VAC/1840VA/192W																	5
<b>Width (mm)</b>	45	45	22,5	100	45	45	22,5	22,5	22,5	22,5	22,5	45	45	22,5	45	45	22,5
<b>Supply voltage</b>																	
12VDC							•										
24VDC	•	•	•	•	•	•	•	•	•	•	•	•	•	•	•	•	•
24VAC	•	•		•	•	•	•					•	•			•	•
48VAC	•	•		•	•	•						•	•			•	
115VAC	•	•		•	•	•						•	•			•	
230VAC	•	•		•	•	•						•	•			•	

\* Indicates the possibility of selecting delayed outputs    ‡ Indicates one relay contact per output (other relays having two contacts per output)  
<sup>‡</sup> delayed    ° Category 4 depending on connection (When used as expansion relay with Pluto Safety PLC, then Category 4)    † fixed 0.5 s delay

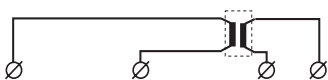

**Contact strips/Safety mats**  
Category 3, up to PL d

For an unpressurised mat/strip, both the relay inputs must be closed for the outputs to be activated. In the case of an activated mat/strip and short-circuit input channels, the relay will be de-energized. Current limitation prevents the safety relay from being overloaded when the channels short-circuit.

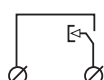

**Monitored manual reset**

A monitored reset means that the safety relay will not be reset if the reset button gets jammed when pressed in or if the input short-circuits. In order for the resetting to be complete, the input must be closed and opened before the outputs can close.



**Automatic/unmonitored manual reset**

Automatic reset means that the outputs are closed immediately when both the input conditions are satisfied and the test input is closed.

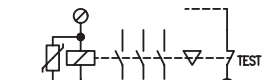

**Testing of contactors, relays & valves**

Can be carried out with both automatic and manual reset.

# Safety relay

# RT6



## Approvals:



## Safety relay for:

- Emergency stops
- Light curtains
- Three position devices
- Interlocked gates/hatches
- Magnetic switches
- Light beams
- Safety mats
- Contact strips
- Foot operated switches

## Features:

- Five input options
- Single or dual channel input
- Manual supervised or automatic reset
- Test input for supervision of external contactors
- Width 45 mm
- LED indication of supply, inputs, outputs, short-circuit and low voltage level.
- 3 NO/1 NC relay outputs
- Two voltage free transistor information outputs
- Supply 24 VDC, 24, 48, 115 or 230 VAC
- Quick release connector blocks

### Would you like a single safety relay for all your safety applications?

Then choose the RT6 universal relay to supervise both your safety devices and the internal safety of your machinery. In addition you can select the safety level required for each installation. All this is possible because the RT6 has the most versatile input option arrangement available on the market. Many other relays can therefore be replaced by the RT6.

The relay also comes with other options such as manual or automatic reset. Manual supervised reset can be used for gates and other safety devices that can be bypassed. Automatic reset can be used for small hatches, if deemed acceptable from risk assessment.

The RT6 also has information outputs that follow the inputs and outputs of the relay. These outputs will for example indicate if a gate is open or closed and if the safety relay needs to be reset.

The RT6 is designed with a minimum amount of components thus keeping both production costs and component acquisitions to a minimum.

Choose the RT6 to simplify your safety circuits and reduce your costs.



## Technical information - RT6

### Inputs

The inputs from the safety devices must be connected according to one of the following options in order to fulfill the expected safety level and to avoid unsafe situations.

1. Single channel, 1 NO contact from +24 V DC, category 1, up to PL c
2. Dual channel, 2 NO contacts from +24 V DC, category 3, up to PL d
3. Dual channel 1 NO, 1 NC contact from +24 V DC, category 4, up to PL e
4. Dual channel, 1 NO contact from 0V and 1 NO contact from +24 V DC, category 4, up to PL e
5. Safety mats/contact strips 1 'contact' from 0V and 1 'contact' from +24 V DC, category 3, up to PL d

When the input/inputs are activated and the test/supervised reset is complete, relays 1 and 2 are energized. Simultaneous activation is not required where there are dual channels. The two relays are de-energized when the input/inputs are de-activated in accordance with the input option chosen or in case of a power failure. Relays 1 and 2 must both be de-energized before the outputs can be activated again.

### Transistor output status information

The RT6 has two voltage free transistor outputs that can be connected to a PLC, computer or other monitoring device. These outputs give the input and output status of the relay.

### Reset and testing

The RT6 has two reset options; manual and automatic. The manual supervised reset is used when the RT6 is monitoring safety devices that can be bypassed, i.e. to ensure that the outputs of the safety relay do not close just because a gate is closed. The automatic reset should only be used if deemed an acceptable risk.

In addition, the RT6 can also test (supervise) whether, for example, contactors and valves etc are de-energized/de-activated before a restart is allowed.

### Indication of low voltage

The 'On' LED will flash if the relay supply voltage falls below an acceptable level. This indication will also be given if a monitored safety mat/contact strip is actuated. See connection option 5.

### Safety level

The RT6 has internal dual and supervised safety functions. A short-circuit, internal faulty component or external interference will not present a risk to options with the highest safety level. A manual reset requires that the reset input is closed and opened before the safety relay outputs are activated. A short-circuit or a faulty reset button is consequently supervised.

When the RT6 is configured for dual channel input, both the inputs are supervised for correct sequence operation before the unit can be reset.

The input options 3 and 4 have the highest safety levels as all short-circuits and power failures are supervised. This in combination with internal current limitation makes the relay ideal for supervision of safety mats and contact strips.

### Regulations and standards

The RT6 is designed and approved in accordance with appropriate directives and standards. See technical data.

### Connection examples

For examples of how our safety relays can solve various safety problems, see the section "Connection examples".

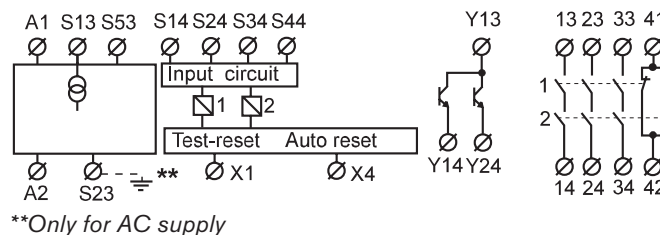

## Connection of supply - RT6

### DC supply

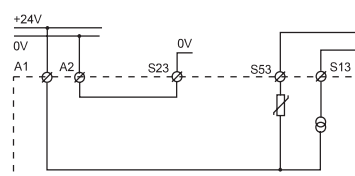

The RT6 DC option should be supplied with +24 V on A1 and 0 V on A2.

### AC supply

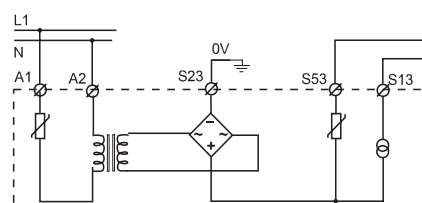

The RT6 AC option should be supplied with the appropriate supply voltage via connections A1 and A2.

The S23/PE must be connected to protective earth.

### DC-supply of AC-units

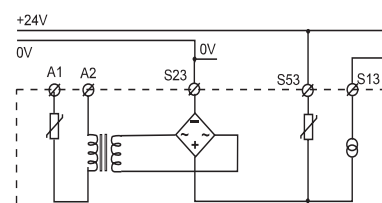

All AC-units can also be supplied by +24 VDC to S53 (0VDC to S23).

### NOTE!

With both DC and AC modules, if cable shielding is used this must be connected to an earth rail or an equivalent earth point.

## Connection of safety devices - RT6

### 1. SINGLE CHANNEL, 1 NO from +24V

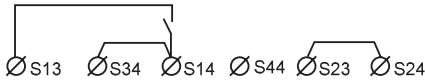

The input (contact to S14) must be closed before the outputs can be activated. When the input contact is opened the relay safety output contacts open.

### 2. DUAL CHANNEL, 2 NO from +24V

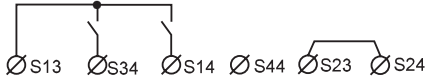

Both input contacts (S14 and S34) must be closed before the relay outputs can be activated. The safety relay contacts will open if one or both of the input contacts are opened. Both the input contacts must be opened and reclosed before the relay can be reset. A short-circuit between inputs S14 and S34 can only be supervised if the device connected to the inputs has short-circuit supervised outputs, e.g. JOKAB Focus light curtains.

### 3. DUAL CHANNEL, 1 NO, 1 NC from +24V

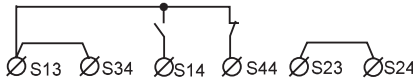

One input contact must be closed (S14) and one opened (S44) before the relay outputs can be activated. The safety relay contacts will open if one or both of the inputs change state or in case of a short-circuit between S14 and S44. Both inputs must return to their initial positions before the relay outputs can be reactivated.

### 4. DUAL CHANNEL, 1 NO from +24V, 1 NO to 0V

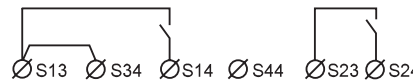

Relay functions as for option 2, but a short-circuit, in this case between inputs S14 and S24, is supervised (safety outputs are opened).

### 5. Safety mat/Contact strip

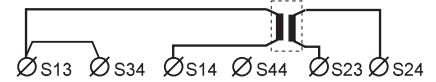

Both 'contact' inputs from a inactivated safety mat/contact strip must be made in order to allow the RT6 relay outputs to be activated. When the safety mat/contact strip is activated or a short-circuit is detected across S14-S23, the relay will de-energize (safety outputs open) and the 'ON' LED will flash. As output S13 has an internal current limit of 70 mA, the RT6 will not be overloaded when the mat/contact strip is activated or a short-circuit is detected.

## Reset connections - RT6

### Manual supervised reset

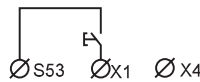

The manual supervised reset contact connected to input X1 must be closed and opened in order to activate the relay outputs.

### Automatic reset

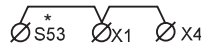

\*connected to S13 for safety mat/contact strip

Automatic reset is selected when S53, X1 and X4 are linked. The relay outputs are then activated at the same time as the inputs.

### Testing external contactor status

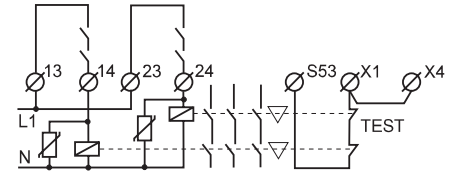

Contactors, relays and valves can be supervised by connecting 'test' contacts between S53 and X1. Both manual supervised and automatic reset can be used.

## Output connections - RT6

### Relay outputs

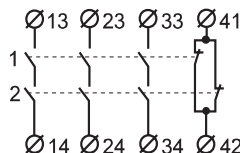

The RT6 has three (3 NO) safety outputs and 1 NC information output.

In order to protect the output contacts it is recommended that loads (inductive) are suppressed by fitting correctly chosen VDR's, diodes etc.

Diodes are the best arc suppressors, but will increase the switch off time of the load.

### Transistor outputs

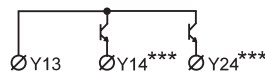

The RT6 has two(2) voltage free transistor outputs for information.

The transistor outputs are supplied with voltage to Y13, either from S53 (+24V) or an external 5-30 VDC supply. Y14 and Y24 follow the relay inputs and outputs as follows:

- Y14 becomes conductive when the relay input conditions are fulfilled.
- Y24 becomes conductive when both the output relays are activated.

### \*\*\*NOTE

These outputs are only for information purposes and must not be connected to the safety circuits of the machinery.

Technical data - RT6	
<b>Manufacturer</b>	ABB AB/Jokab Safety, Sweden
<b>Article number/Ordering data</b>	RT6 24DC 2TLA010026R0000 RT6 24 AC 2TLA010026R0200 RT6 115 AC 2TLA010026R0400 RT6 230 AC 2TLA010026R0500
<b>Colour</b>	Grey
<b>Weight</b>	335 g (24 VDC) 485 g (24-230 VAC)
<b>Supply</b>	Voltage (A1-A2) 24 VDC +15/-20%, 24/48/115/230 VAC, +15/-10%, 50-60 Hz
<b>Power consumption</b>	DC supply, nominal voltage 2.3 W AC supply, nominal voltage 5.2 VA
<b>Connection S13</b>	Short-circuit protected voltage output, 70 mA ± 10% current limitation. Is used for the inputs S14, S34 and S44.
<b>Connection S53</b>	Short-circuit protected voltage output, internal automatic fuse 270 mA. Is used for the reset and autoreset inputs X1 and X4
<b>Connection S23</b>	0V connection for input S24
<b>Safety inputs</b>	S14 (+) input 20 mA S24 (0V) input 20 mA S34 (+) input 20 mA S44 (+) input 30 mA
<b>Reset input X1</b>	Supply for reset input + 24VDC Reset current 300 mA current pulse at contact, then 30 mA Minimum contact closure time for reset 100 ms
<b>Maximum external connection cable resistance at nominal voltage for</b>	S14, S24, S34 300 Ohm S44, X1 150 Ohm
<b>Response time</b>	At Power on DC/AC <90ms/<220ms When activating (input-output) <20 ms When deactivating (input-output) <20 ms At Power Loss <150 ms
<b>Relay outputs</b>	NO 3 NC 1 Maximum switching capacity Resistive load AC 6A/250 VAC/1500 VA Inductive load AC AC15 240VAC 2A Resistive load DC 6A/24 VDC/150 W Inductive load DC DC13 24VDC 1A Maximum total switching capacity Resistive load 12A distributed on all contacts Minimum load 10mA/10 V (if load on contact has not exceeded 100 mA) Contact material Ag+Au flash Fuses Output (External) 5A gL/gG Conditional short-circuit current (1 kA) 6A gG Mechanical life >10 <sup>7</sup> operations

<b>Transistor outputs</b>	Short-circuit proof +5 to +30 VDC Indicates that the input conditions have been fulfilled Indicates that the output relays are activated 15 mA /output 2.4 V
External supply to Y13 Y14 Y24 Maximum load of Y14, Y24 Maximum voltage drop at maximum load	
<b>LED indication</b>	Supply voltage OK, the LED is on. Flashing light in case of under-voltage or overload Indicates that the input conditions are fulfilled. Indicates that the output relays are activated.
On ● In1 ● In2 ● <input checked="" type="checkbox"/> ● 1 <input checked="" type="checkbox"/> ● 2	
<b>Mounting</b>	Rail 35 mm DIN rail
<b>Connection blocks (detachable)</b>	Maximum screw torque 1 Nm Maximum connection area: Solid conductors 1x4mm <sup>2</sup> /2x1,5mm <sup>2</sup> /12AWG Conductor with socket contact 1x2,5mm <sup>2</sup> /2x1mm <sup>2</sup>
<b>Protection class</b>	Enclosure IP 40 IEC 60529 Connection blocks IP 20 IEC 60529
<b>Operating temperature range</b>	-10°C to + 55°C (with no icing or condensation)
<b>Operating humidity range</b>	35% to 85%
<b>Impulse Withstand Voltage</b>	2.5kV
<b>Pollution Degree</b>	2
<b>Performance (max.)</b>	Category 4/PL e (EN ISO 13849-1:2008) SIL 3 (EN 62061:2005) PFH <sub>d</sub> 9.55E-09
<b>Conformity</b>	2006/42/EC, 2006/95/EC, 2004/108/EC EN 954-1:1996, EN 62061:2005 EN ISO 13849-1:2008

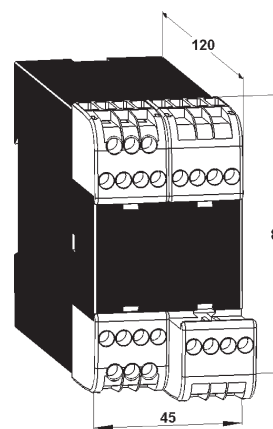

Connector blocks are detachable (without cables having to be disconnected)

# Safety relay

# RT7

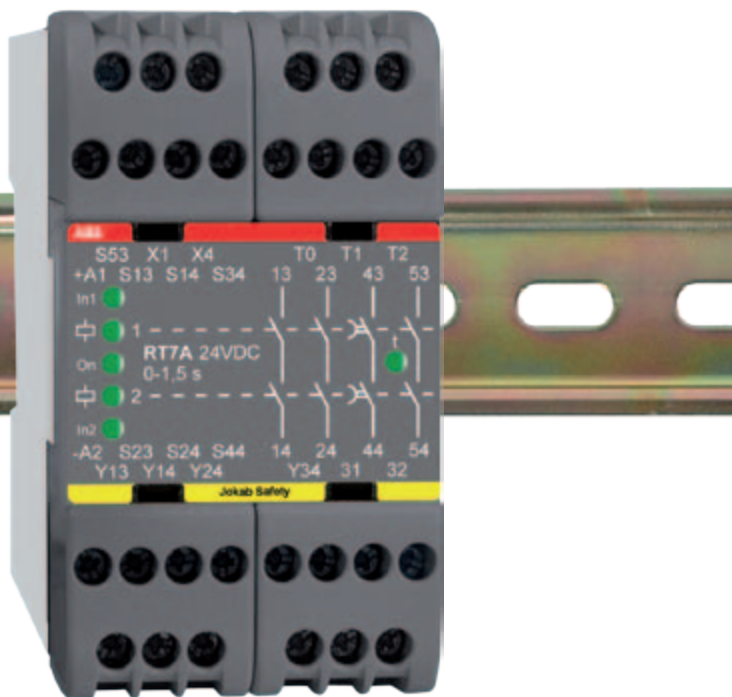

## Approvals:



## Safety relay for:

- Emergency stops
- Light curtains
- Three position devices
- Interlocked gates/hatches
- Magnetic switches
- Light beams
- Safety mats
- Contact strips
- Foot operated switches

## Features:

- 4 NO/1 NC relay outputs, 2 NO outputs can be delayed for soft stops
- Delay times RT7A 0; 0,5; 1,0; 1,5 s RT7B 0; 1,0; 2,0; 3,0 s
- Five input options
- Single or dual channel input
- Manual supervised or automatic reset
- Test input for supervision of external contactors
- Width 45 mm
- LED indication of supply, inputs, outputs, short-circuit and low voltage level
- Three voltage free transistor information outputs
- Supply 24 VDC, 24, 48, 115 or 230 VAC
- Quick release connector blocks

### Universal relay with delayed outputs

The RT7 is a universal relay that can be used to supervise both safety devices and the internal safety of your machinery. In addition, you can select the safety level that is required for each installation. All this is possible because the RT7 has the most versatile input options arrangement available on the market. The RT7 can therefore replace many other relays.

The RT7 has four (4 NO) dual safety outputs of which two may be delayed for up to three seconds in order to achieve a safe and 'soft' stop. A 'soft' stop allows machinery to brake and stop gently before power is removed. A 'soft' stop has many benefits: the machinery life will be prolonged, processed products will not be damaged, and restarts from the stopped position are made possible and easier.

Another option with the RT7 is manual or automatic resetting. A manual supervised reset is used for gates and other safety devices that can be bypassed, while an automatic reset is used for small safety hatches if deemed appropriate from a risk point of view.

In addition, the RT7 has information outputs that follow the inputs and outputs of the relay. These outputs indicate if for example a gate is opened or closed, if there is a delay or if the relay needs to be reset.

Choose the RT7 to simplify your safety circuits and reduce your costs.

## Technical information - RT7 A/B

### Inputs

The RT7 can be configured to operate in either of the following input options:

1. Single channel, 1 NO contact from +24 VDC, safety category 1, up to PL c
2. Dual channel, 2 NO contacts from +24 VDC, category 3, up to PL d
3. Dual channel, 1 NO, 1 NC contact from +24 VDC, category 4, up to PL e
4. Dual channel, 1 NO contact from 0V and 1 NO contact from +24 VDC, category 4, up to PL e
5. Safety mats/contact strips, 1 'contact' from 0V and 1 'contact' from +24 VDC, category 3, up to PL d

When the input/inputs are activated and the test/supervised reset is complete, relays 1,2,3 and 4 are activated. Relays 1 and 2 are immediately de-energized when the inputs are deactivated in accordance with the input option selected. Relays 3 and 4 are either de-energized immediately or after the selected time delay. All the relays (1,2,3 and 4) must be de-energized before the RT7 can be reset.

### Transistor output status information

The RT7 has three(3) voltage free transistor outputs that can be connected to a PLC, computer or other monitoring device. These outputs give the input and output status of the relay.

### Reset and testing

The RT7 has two reset options; manual and automatic.

The manual supervised reset is utilised when the RT7 is used to monitor safety devices that can be bypassed, i.e. to ensure that the outputs of the safety relay do not close just because the gate is closed.

The automatic reset should only be used if acceptable from a risk point of view. The RT7 can also test (supervise), if for example, contactors and valves etc are de-energized/de-activated before a restart is allowed.

### Indication of low voltage

The 'On' LED will flash if the relay voltage falls below an acceptable level. This indication will also be given if a monitored safety mat contact strip is actuated. See connection option 5.

### Safety level

The RT7 has internal dual and supervised safety functions. Power failure, an internal faulty component or external interference will not present a risk to options with the highest safety level. A manual reset requires that the reset input is closed and opened before the safety relay outputs are activated. A short-circuit or a faulty reset button is consequently supervised.

When the RT7 is configured for dual channel input, both the inputs are supervised for correct sequence operation before the unit can be reset. The input options 3 and 4 have the highest safety levels as all short-circuits and power failures are supervised. This in combination with internal current limitation makes the relay ideal for supervision of safety mats and contact strips.

### Regulations and standards

The RT7 is designed and approved in accordance with appropriate directives and standards. Se tekniska data.

### Connection examples

For examples of how our safety relays can solve various safety problems, see the section "Connection examples".

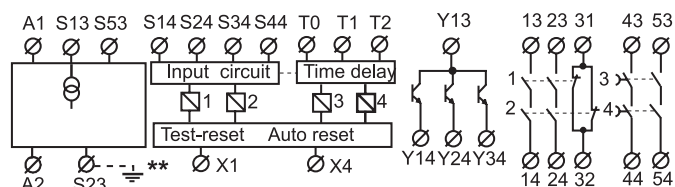

\*\*Only for AC supply

## Connection examples – RT7

### DC supply

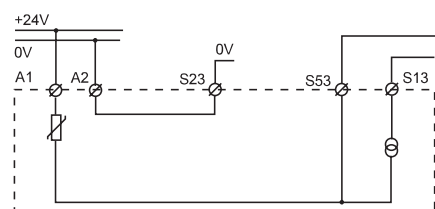

The RT7 DC option should be supplied with +24 V on A1 and 0 V on A2.

### AC supply

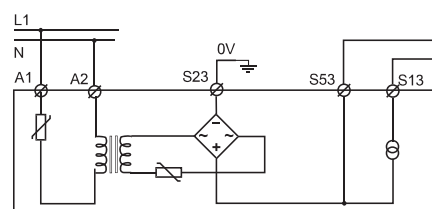

The RT7 AC option should be supplied with the appropriate supply voltage via connections A1 and A2.

The S23/⊥ must be connected to protective earth

### DC-supply of AC-units

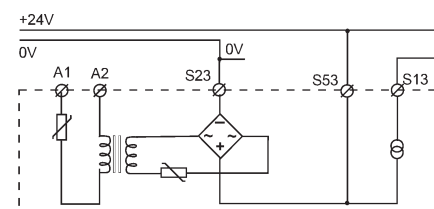

Samtliga AC-moduler kan också matas med +24 VDC på S53 och 0V på S23.

### NOTE

With both DC and AC modules, if cable shielding is used this must be connected to an earth rail or an equivalent earth point.



## Connection of safety devices - RT7 A/B

### 1. SINGLE CHANNEL, 1 NO from +24V



The input (contact to S14) must be closed before the outputs can be activated. When the input contact is opened the relay safety output contacts open.

### 2. DUAL CHANNEL, 2 NO from +24V

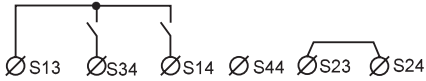

Both input contacts (S14 and S34) must be closed before the relay outputs can be activated. The safety relay contacts will open if one or both of the input contacts are opened. Both the input contacts must be opened before the relay can be reset. A short-circuit between the inputs S14 and S34 can only be supervised if the device connected to the inputs has short-circuit supervised outputs, e.g. ABB Jokab Safety's Focus light curtains.

### 3. DUAL CHANNEL, 1 NO, 1 NC from +24V

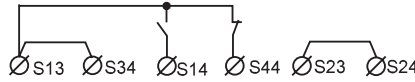

One input contact must be closed (S14) and one opened (S44) before the relay outputs can be activated. The safety relay contacts will open if one or both of the inputs change state or in the case of a short-circuit between S14 and S44. Both inputs must be returned to their initial positions before the relay outputs can be reactivated.

### 4. DUAL CHANNEL, 1 NO from +24V, 1 NO from 0V



Relay functions as option 2, but a short-circuit, in this case between inputs S14 and S24, is supervised (safety outputs are opened).

### 5. Safety mat/Contact strip

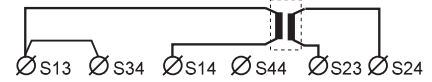

Both 'contact' inputs from an inactivated safety mat/contact strip, must be made in order to allow the RT7 relay outputs to be activated. When the safety mat/contact strip is activated or a short-circuit is detected across S14-S23, the relay will de-energize (safety outputs open) and the 'ON' LED will flash. As output S13 has an internal current limit of 70 mA, the RT7 will not be overloaded when the mat/contact strip is activated or a short circuit is detected.

## Reset connections - RT7 A/B

### Manual supervised reset

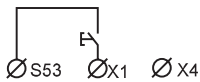

The manual supervised reset contact connected to input X1 must be closed and opened in order to activate the relay outputs.

### Automatic reset



\*connected to S13 for safety mat/contact strip

Automatic reset is selected when S53, X1 and X4 are linked. The relay outputs are then activated at the same time as the inputs.

### Testing external contactor status

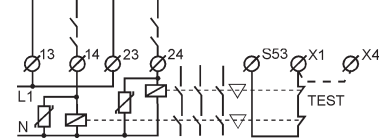

Contactors, relays and valves can be supervised by connecting 'test' contacts between S53 and X1. Both manual supervised and automatic reset can be used.

## Output connections - RT7 A/B

### Relay outputs

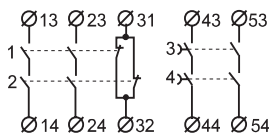

The RT7 has four (4 NO) safety outputs of which two can be delayed, and 1 NC information output.

In order to protect the RT7 output contacts it is recommended that loads (inductive) are suppressed by fitting correctly chosen VDR's, diodes etc. Diodes are the best arc suppressors, but will increase the switch off time of the load.

#### \*\*\*NOTE

These outputs are only for information purposes and must not be connected to the safety circuits of the machinery.

### Transistor outputs

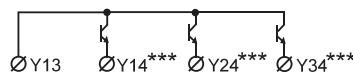

The RT7 has three (3) voltage free transistor information outputs.

The transistor outputs are supplied with voltage to Y13 either from S53 (+24V) or externally from 5 to 30 VDC. Y14, Y24 and Y34 follow the inputs and outputs as follows:

- Y14 becomes conductive when the relay input conditions are fulfilled.
- Y24 becomes conductive when both the output relays are activated.
- Y34 becomes conductive when both the delay output relays are activated.

### Time delay outputs

RT7A	RT7B	T0	T1	T2	RT7A	RT7B	T0	T1	T2
0.0s	0.0s				1.0s	2.0s			
0.5s	1.0s				1.5s	3.0s			

Time delays are selected by linking the appropriate T0, T1 and T2 connections.

When a stop signal is detected a program stop command is first given to the PLC/servo which brakes the dangerous machine operations in a 'soft' and controlled way.

The delayed relay safety outputs will then turn off the power to the motors, i.e. when the machinery has already stopped. It takes usually around 0.5 to 3 seconds for a dangerous action to be stopped softly.



Technical data - RT7 A/B		
<b>Manufacturer</b>		ABB AB/Jokab Safety, Sweden
<b>Article number/Ordering data</b>		
RT7B 24DC 3 s		2TLA010028R1000
115AC 3 s		2TLA010028R1400
230AC 3 s		2TLA010028R1500
RT7A 24DC 1,5 s		2TLA010028R2000
115AC 1,5 s		2TLA010028R2400
230AC 1,5 s		2TLA010028R2500
<b>Colour</b>		Black and beige
<b>Weight</b>		405 g (24 VDC) 550 g (24-230 VAC)
<b>Supply</b>		
Voltage (A1-A2)		24 VDC +15/-20%, 24/48/115/230 VAC, ±15%, 50-60 Hz
<b>Power consumption</b>		
DC supply, nominal voltage		4.6 W
AC supply, nominal voltage		8.8 VA
<b>Connection S13</b>		
Short-circuit protected voltage output, 70 mA ±10% current limitation. Is used for the inputs S14, S34 and S44.		
<b>Connection S53</b>		
Short-circuit protected voltage output, internal automatic fuse, max 270 mA. Is used for the reset and autoreset inputs X1 and X4.		
<b>Connection S23</b>		
0V connection for input S24.		
<b>Safety inputs</b>		
S14 (+) input		20 mA
S24 (0V) input		20 mA
S34 (+) input		20 mA
S44 (+) input		25 mA
<b>Reset input X1</b>		
Supply for reset input		+ 24VDC
Reset current		600 mA current pulse at contact closure, then 30 mA.
Minimum contact closure time for reset		100 ms
<b>Maximum external connection cable resistance at nominal voltage for</b>		
S14, S24, S34		300 Ohm
S44, X1		150 Ohm
<b>Response time</b>		
At Power on DC/AC		<90/<140 ms
When activating (input-output)		<20 ms
When deactivating (input-output)		<20 ms
At Power Loss		<80 ms
<b>Delay time options</b>		
RT7A		0; 0.5; 1.0; 1.5 secs
RT7B		0; 1.0; 2.0; 3.0 secs
<b>Relay outputs</b>		
NO direct (relays 1/2)		2
NO direct or delayed (relays 3/4)		2
NC (relays 1/2)		1
Maximum switching capacity		
Relays 1/2 Resistive load AC		6A/250 VAC/1500 VA
Inductive load AC		AC15 240VAC 2A
Resistive load DC		6A/24 VDC/150 W
Inductive load DC		DC13 24VDC 1A
Relays 1/2 total		Max 9A distributed on all contacts
Relays 3/4 Resistive load AC		6A/230 VAC/1380 VA
Inductive load AC		AC15 230VAC 4A
Resistive load DC		6A/24VDC/144W
Inductive load DC		DC13 24VDC 2A

Relays 3/4 total	Max 6A distributed on all contacts
Contact material	AgSnO <sub>2</sub> + Au flash
Fuses output 1/2 (external)	5A gL/gG
Fuses output 3/4 (external)	3A gL/gG
Conditional short-circuit current (1 kA), each output	6A gG
Mechanical life	>10 <sup>7</sup> operations
<b>Transistor outputs</b>	
External supply to Y13	+5 to +30 VDC
Y14	Indicates that the input conditions are fulfilled
Y24	Indicates that the output relays 1/2 are activated
Y34	Indicates that the delay output relays 3/4 are activated
Maximum load of Y14, Y24, Y34	15 mA /output
Maximum voltage drop at maximum load	2.4 V
<b>LED indication</b>	
On ●	Supply voltage OK, the LED is on. Flashing light in case of under-voltage or overload.
In1 ● In2 ●	Indicates that the input conditions are fulfilled.
☑ ● 1 ☑ ● 2	Indicates that the output relays 1/2 are activated.
t ●	Indicates that the delay output relays 3/4 are activated.
<b>Mounting</b>	
Rail	35 mm DIN rail
<b>Connection blocks (detachable)</b>	
Maximum screw torque	1 Nm
Maximum connection area:	
Solid conductors	1x4mm <sup>2</sup> /2x1,5mm <sup>2</sup> /12AWG
Conductor with socket contact	1x2,5mm <sup>2</sup> /2x1mm <sup>2</sup>
<b>Protection class</b>	
Enclosure	IP 40 IEC 60529
Connection blocks	IP 20 IEC 60529
<b>Operating temperature range</b>	
24VDC	-10° C to + 55° C (with no icing or condensation)
24-230VAC	-10° C to + 45° C (with no icing or condensation)
<b>Operating humidity range</b>	
35% to 85%	
<b>Impulse Withstand Voltage</b>	
2.5kV	
<b>Pollution Degree</b>	
2	
<b>Performance (max.)</b>	
The relays must be cycled at least once a year.	
Category 4/PL e (EN ISO 13849-1:2008)	
SIL 3 (EN 62061:2005)	
PFH <sub>d</sub> 9.55E-09	
<b>Conformity</b>	
2006/42/EC, 2006/95/EC, 2004/108/EC	
EN 954-1:1996, EN 62061:2005	
EN ISO 13849-1:2008	

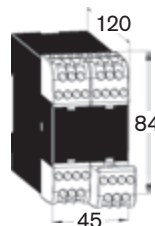

Connector blocks are detachable (without cables having to be disconnected)

# Safety relay

# RT9



## Approvals:



## Safety relay for:

- Emergency stops
- Light curtains
- Three position devices
- Interlocked gates/hatches
- Magnetic switches
- Light beams
- Safety mats
- Contact strips
- Foot operated switches

## Features:

- Five input options
- Single or dual channel input
- Manual supervised or automatic reset
- Test input for supervision of external contactors
- Width 22.5 mm
- LED indication of supply, inputs and outputs, short-circuit and low voltage level
- 2 NO relay outputs
- One changeover relay with a double information output
- Supply 24 VDC
- Quick release connector blocks

### Would you like a small safety relay for all your safety applications?

Then choose the compact RT9 universal relay to supervise both your safety devices and the internal safety of your machinery. In addition, you can select the safety level that is required for each installation. All this is possible due to the RT9 offering the most versatile input option arrangement available on the market. The RT9 can therefore replace many other relays.

Other RT9 options include selection of either manual supervised or automatic resetting. The manual supervised reset can be used for gates and other safety devices that can be bypassed. Automatic reset can be used for small safety hatches, if deemed acceptable from risk assessment.

In addition, the RT9 has a double information output that will indicate e.g. if a gate is open or if the relay needs resetting.

The RT9 uses the latest component technology and modern assembly techniques to ensure a highly cost effective solution.

Choose the RT9 to simplify your safety circuits and reduce your costs.

## Technical information – RT9

### Inputs

The RT9 can be configured to operate in either of the following input options:

1. Single channel, 1 NO contact from +24VDC, category 1, up to PL c
2. Dual channel, 2 NO contacts from +24VDC, category 3, up to PL d
3. Dual channel, 1 NO, 1 NC contact from +24VDC, category 4, up to PL e
4. Dual channel, 1 NO contact from 0V and 1 NO contact from +24VDC, category 4, up to PL e
5. Safety mat/contact strips, 1 'contact' from 0V and 1 'contact' +24VDC, category 3, up to PL d

When the input/inputs are activated and the test/supervised reset is complete, relays 1 and 2 are energised. These are de-energised when the input/inputs are de-activated in accordance with the input option chosen or in case of a power failure.

Relays 1 and 2 must both be de-energised before the RT9 can be reset.

### Relay output status information

The RT9 has a changeover contact relay output that can be connected to a PLC, control lamp, computer or similar. The output gives information about the status of the relay.

### Reset and testing

The RT9 has two reset options; manual and automatic. The manual supervised reset can be used when the RT9 is monitoring safety devices that can be bypassed, i.e. to ensure that the outputs of the safety relay do not close just because a gate is closed. The automatic reset option should only be used if appropriate from a risk point of view.

Due to special internal circuits the RT9 can be automatically reset regardless of the operational voltage rise time, this being an important factor when large loads are started up on the same power supplies at the same time.

In addition, the RT9 can also test (supervise), if for example, contactors and valves etc are de-energised/de-activated before a restart is made.

### Indication of low voltage

The 'On' LED will flash if the relay supply voltage falls below an acceptable level. This indication will also be given if a monitored safety mat/contact strip is actuated. Please see Connection option 5.

### Safety level

The RT9 has internal dual and supervised safety functions. Power failure, an internal faulty component or external interference will not present a risk to options with the highest safety level. A manual reset requires that the reset input is closed and opened before the safety relay outputs are activated. A short-circuit or a faulty reset button is consequently supervised.

When the RT9 is configured for dual channel input, both the inputs are supervised for correct operation before the unit can be reset.

The input options 3 and 4 have the highest safety levels as all short-circuits and power failures are supervised. This in combination with an internal current limitation makes the relay ideal for supervision of safety mats and contact strips.

### Regulations and standards

The RT9 is designed and approved in accordance with appropriate directives and standards. See technical data.

### Connection examples

For examples of how our safety relays can solve various safety problems, please see the section "Connection examples".

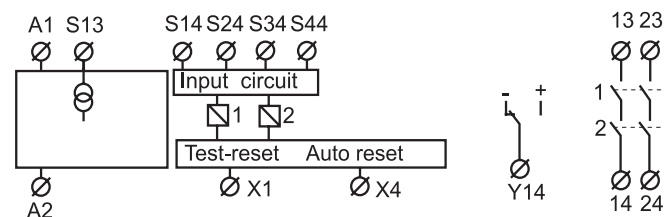

## Connection of supply - RT9

### DC supply

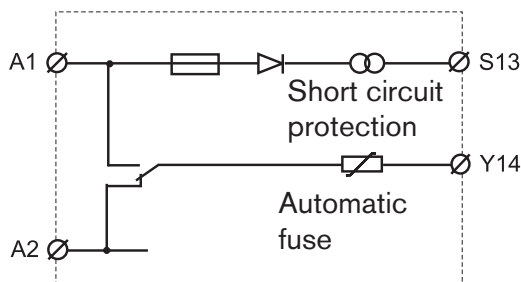

The RT9 should be supplied with +24 V on A1 and 0 V on A2.

### NOTE

If cable shielding is used this must be connected to an earth rail or an equivalent earth point.

## Connection of safety devices - RT9

### 1. SINGLE CHANNEL, 1 NO from +24V



The input (contact to S14) must be closed before the outputs can be activated. When the input contact is opened, the relay safety output contacts open.

### 2. DUAL CHANNEL, 2 NO from +24V

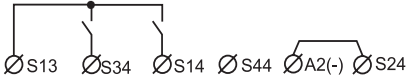

Both input contacts (S14 and S34) must be closed before the relay outputs can be activated. The safety relay contacts will open if one or both of the input contacts are opened. Both the input contacts must be opened and reclosed before the relay can be reset.

A short-circuit between inputs S14 and S34 can only be supervised if the device connected to the inputs has short-circuit supervised outputs, e.g. ABB Jokab Safety's Focus light curtains

### 3. DUAL CHANNEL, 1 NO, 1 NC from +24V

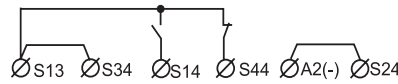

One input contact must be closed (S14) and one opened (S34) before the relay outputs can be activated.

The safety relay contacts will open if one or both of the inputs change state or in case of a short-circuit between S14 and S44. Both inputs must be returned to their initial status before the relay outputs can be reactivated.

### 4. DUAL CHANNEL, 1 NO from +24V, 1 NO from 0V

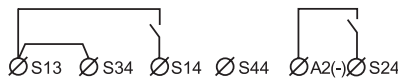

Relay functions as option 2, but a short-circuit, in this case between inputs S14 and S24, is supervised (safety outputs are opened).

### 5. Safety mat/Contact strip

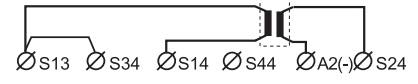

Both 'contact' inputs from a deactivated safety mat/contact strip must be made in order to allow the RT9 relay outputs to be activated. When the safety mat/contact strip is activated or a short-circuit is detected across S14-S23, the relay will de-energize (safety contacts open) and the 'ON' LED will flash. As output S13 has an internal current limit of 70 mA, the RT9 will not be overloaded when the mat/contact strip is activated or a short-circuit is detected.

## Reset connections - RT9

### Manual supervised reset

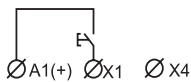

The manual supervised reset contact connected to input X1 must be closed and opened in order to activate the relay outputs.

### Automatic reset

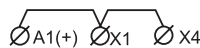

Automatic reset is selected when A1(+), X1 and X4 are linked. The relay outputs are then activated at the same time as the inputs.

### Testing external contactor status

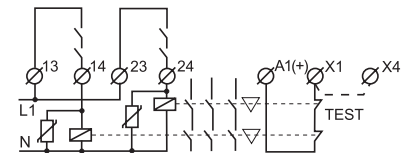

Contactors, relays and valves can be supervised by connecting 'test' contacts between A1(+) and X1. Both manual supervised and automatic reset can be used.

## Output connections - RT9

### Relay outputs

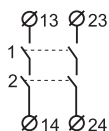

The RT9 has two (2 NO) safety outputs.

In order to protect the output contacts it is recommended that loads (inductive) are suppressed by fitting correctly chosen VDR's, diodes etc. Diodes are the best arc suppressors, but will increase the switch off time of the load.

### Information outputs



The RT9 has a single changeover contact information relay output. The relay output Y14 is connected internally to 0V and 24V in the following way:

- Y14 is internally closed to 0V when the RT9 is not reset.
- Y14 is internally closed to +24V when the relay is reset.

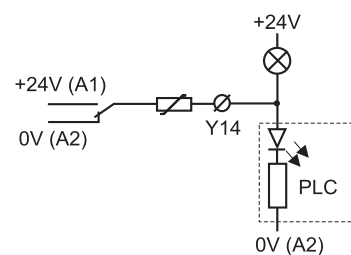

Technical data – RT9	
<b>Manufacturer</b>	ABB AB/Jokab Safety, Sweden
<b>Article number/Ordering data</b> RT9 24DC	2TLA010029R0000
<b>Colour</b>	Grey
<b>Weight</b>	210 g
<b>Supply</b> Voltage (A1-A2)	24 VDC ±20%
<b>Power consumption</b> Nominal voltage	2 W
<b>Connection S13</b>	Short-circuit protected voltage output 70 mA ± 10% current limitation. Is used for the inputs S14, S34 and S44.
<b>Input currents (at nominal supply voltage)</b> S14 (+) input S24 (0V) input S34 (+) input S44 (+) input	30 mA 20 mA 20 mA 25 mA
<b>Reset input X1</b> Supply for reset input Reset current  Minimum contact closure time for reset Minimum contact closure time (at low limit voltage -20%)	+ 24VDC 300 mA current pulse at contact closure, then 30 mA  80 ms 100 ms
<b>Maximum external connection cable resistance at a nominal voltage for</b> S14, S24, S34 S44, X1	300 Ohm 150 Ohm
<b>Response time</b> At Power on When activating (input-output) When deactivating (input-output) At Power Loss	<100 ms <20 ms <20 ms <80 ms
<b>Relay outputs</b> NO Maximum switching capacity Resistive load AC Inductive load AC Resistive load DC Inductive load DC Max. total switching capacity: Minimum load  Contact material	2  6A/250 VAC/1500 VA AC15 240VAC 2A 6A/24 VDC/150 W DC13 24VDC 1A 8A distributed on all contacts 10 mA/10V (if load on contact has not exceeded 100 mA) Ag+Au flash
<b>Fuses Output (External)</b>	5A gL/gG
<b>Conditional short-circuit current (1 kA)</b> Mechanical life	6A gG 10 <sup>7</sup> operations
<b>Relay information output Y14 (Changeover contacts)</b> -(0V) +(24V) Maximum load of Y14 Short-circuit protection for information output	Indicates that RT9 is not reset. Indicates that RT9 is reset. 250 mA  Internal automatic fuse

<b>LED indication</b> On ●  In1 ● In2 ●  ☑ ● 1 ☑ ● 2	Supply voltage OK, the LED is on. Flashing light in case of under-voltage, overload or current limiting Indicates that the input conditions are fulfilled. Indicates that the output relays have been activated.
<b>Mounting</b> Rail	35 mm DIN rail
<b>Connection blocks (detachable)</b> Maximum screw torque Maximum connection area: Solid conductors Conductor with socket contact	1 Nm  1x4mm <sup>2</sup> /2x1,5mm <sup>2</sup> /12AWG 1x2,5mm <sup>2</sup> /2x1mm <sup>2</sup>
<b>Protection class</b> Enclosure Connection blocks	IP 40 IEC 60529 IP 20 IEC 60529
<b>Operating temperature range</b>	-10°C to + 55°C (with no icing or condensation)
<b>Operating humidity range</b>	35% to 85%
<b>Impulse Withstand Voltage</b>	2.5kV
<b>Pollution Degree</b>	2
<b>Performance (max.)</b> The relays must be cycled at least once a year.	Category 4/PL e (EN ISO 13849-1:2008) SIL 3 (EN 62061:2005) PFH <sub>d</sub> 9.55E-09
<b>Conformity</b>	2006/42/EC, 2006/95/EC, 2004/108/EC EN 954-1:1996, EN 62061:2005 EN ISO 13849-1:2008

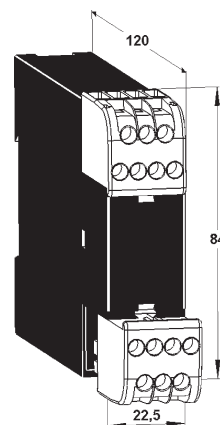

Connector blocks are detachable (without cables having to be disconnected)



## Safety relay

# JSBRT11

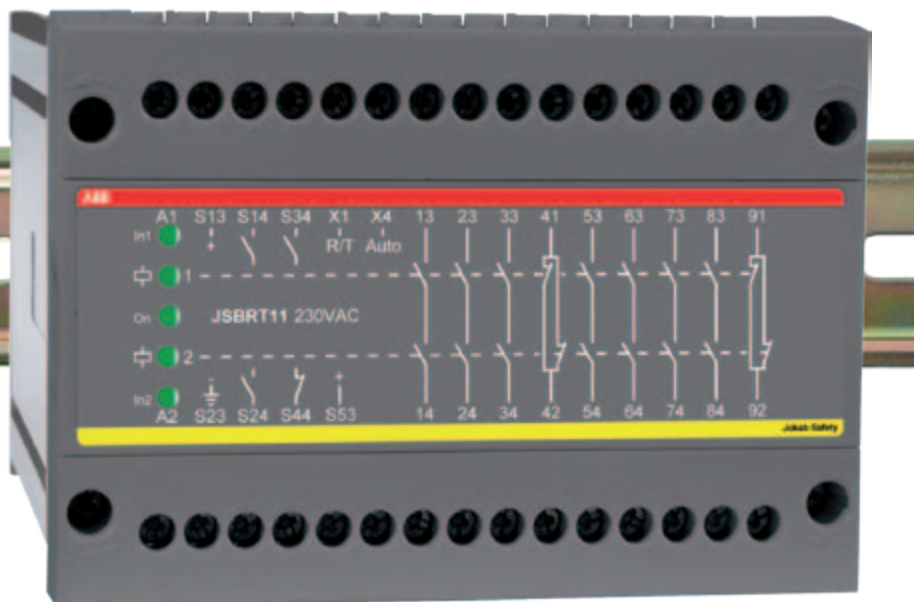

### A flexible safety relay with many outputs

The JSBRT11 has been designed to provide the safety system circuit designer with the ability to select from both a range of input connection configurations and either automatic or supervised reset.

The unit can be hardwire configured to operate in either of the following input configurations:

- Mode 1: Single Channel (1 NO contact from +24 VDC), category 1 PL c
- Mode 2: Dual Channel (2 NO contacts from +24 VDC), category 3 PL d
- Mode 3: Dual Channel (1 NO, 1NC contacts from + 24 VDC), category 4 PL e.
- Mode 4: Dual Channel (1 NO contact from 0 V and 1 NO contact from + 24 VDC), safety category 4.

In addition the unit can also be used to test that contactors and valves have fallen/returned to their 'reset' state before a new 'start' signal is given.

### Safety level

The JSBRT11 has dual and monitored internal safety functions. Power failure, internal component failures or external interference (with the exception of short circuiting of input contact when used in a single channel input mode) do not result in a dangerous function.

When wired for supervised reset, should a short circuit appear across the reset input the relay will not automatically reset when the input/inputs are made. Only when the supervised reset input is made and broken will the relay reset.

The JSBRT11 provides detection of contact failure in the inputs when wired in dual channel mode. Both inputs have to be opened and closed in order to enable the reactivation of the relay.

### Approvals:



### Safety relay for:

- Emergency stop
- Light curtains
- Three position devices
- Interlocked gates/hatches
- Magnetic switches
- Light beams
- Foot operated switches

### Features:

- Selectable inputs and safety category
- Manual supervised or automatic reset
- Width 100 mm
- LED indication for supply, inputs and outputs
- 7 NO + 2 NC relay outputs
- Supply 24 VDC 24, 48, 115 or 230 VAC
- Quick release connector blocks

The highest safety level of the JSBRT11 is in configuration mode 3 and 4 because all short circuits are supervised i.e. a short circuit between the inputs leads to a safe state as the outputs drop out.

### Regulations and standards

The JSBRT11 is designed and approved in accordance with appropriate directives and standards. See technical data.

### Connection examples

For examples of how our safety relays can solve various safety problems, please see the section "Connection examples".



Technical data – JSBRT11	
<b>Manufacturer</b>	ABB AB/Jokab Safety, Sweden
<b>Article number/Ordering data</b> 24 DC 115 AC 230 AC	2TLA010025R0000 2TLA010025R0400 2TLA010025R0500
<b>Colour</b>	Grey
<b>Power supply A1 - A2</b>	24 VDC ± 15% 24, 48, 115, 230 VAC ± 15%, 50-60 Hz
<b>Power consumption</b>	3.2 W/7.9 VA
<b>Relay Outputs</b>	7 NO and 2 NC
<b>Max. switching capacity</b> Resistive load AC Inductive load AC Resistive load DC Inductive load DC	6A/250 VAC/1500 VA AC15 240VAC 2A 6A/24 VDC/150 W DC13 24VDC 1A
<b>Max. total switching capacity</b>	21A distributed on all contacts
<b>Min. load</b>	10mA/10 V (if load on contact has not exceeded 100 mA)
<b>Contact material</b>	AgSnO <sub>2</sub> + Au flash
<b>Fuses Output (External)</b>	6A gL/gG
<b>Conditional short-circuit current (1 kA)</b>	6A gG
<b>Max. Input wire res. at nom. voltage</b>	200 Ohm (S14,S24,S34,X1,X4); 100 Ohm (S44)
<b>Response time at deactivation (input-output)</b>	<20 ms
<b>Response time at activation (input-output)</b>	<30 ms

<b>Terminals (Max. screw torque 1 Nm)</b> Single strand: Conductor with socket contact:	1x4 mm <sup>2</sup> /2x1.5 mm <sup>2</sup> 1x2.5 mm <sup>2</sup> /2x1mm <sup>2</sup>
<b>Mounting</b>	35 mm DIN-rail
<b>Protection class</b> enclosure terminals	IP 40 IEC 60259 IP 20 IEC 60259
<b>Impulse Withstand Voltage</b>	2.5kV
<b>Pollution Degree</b>	2
<b>Operating temperature range</b>	-10°C to +55°C (with no icing or condensation)
<b>Operating humidity range</b>	35% to 85%
<b>Function indication</b>	Electrical Supply, Input 1 and 2, Output relays 1 and 2
<b>Weight</b>	610 g (24 VDC) 790 g (24- 230 VAC)
<b>Performance (max.)</b> Functional test: The relays must be cycled at least once a year.	Category 4/PL e (EN ISO 13849-1:2008) SIL 3 (EN 62061:2005) PFH <sub>d</sub> 1.69E-08
<b>Conformity</b>	2006/42/EC, 2006/95/EC, 2004/108/EC EN 954-1:1996, EN 62061:2005 EN ISO 13849-1:2008

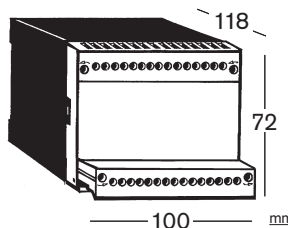

Connector blocks are detachable (without cables having to be disconnected)

## Technical description – JSBRT11

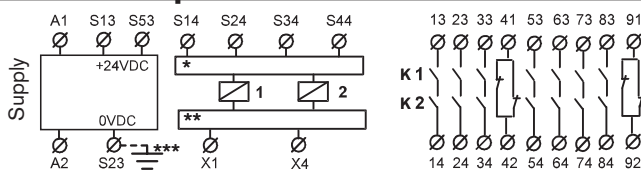

\*Supervision circuit \*\*Test and Automatic reset circuit \*\*\* Only for AC-supply

The supply voltage is connected across A1 and A2. The input connection configuration and type of reset required is set by connecting the unit as shown in the diagrams below.

When the input/inputs and the test/supervised reset are made K1 and K2 energise. K1 and K2 will de-energise if the power is disconnected or a stop signal is given in accordance to the configuration mode wired. Both K1 and K2 have to be de-activated before the outputs of the JSBRT11 can be closed again.

### Configuration mode 1.

When the single input opens both K1 and K2 relays are deactivated.

### Configuration mode 2.

Both inputs have to be closed in order to enable the unit to be activated. A stop signal is given if both or one input is opened. Both inputs have to be opened and reclosed in order to enable the reactivation of the unit. If the possibility of short circuits between the inputs cannot be excluded, configuration mode 3 or 4 should be used in order to reach the highest safety level.

### Configuration mode 3.

One input has to be closed and the other input has to be opened in order to enable the unit to be activated. A stop signal is given if both or one input change state.

Both inputs have to change state in order to give a dual stop function and to allow a new start after stop.

### Configuration mode 4

Operation as mode 2 but short circuits between the inputs leads to a safe state i.e. the relays inside the JSBRT11 will drop out.

### Supervised reset connection.

The input to X1 (see diagram below) has to be closed and opened in order to activate the unit, after input/inputs are made according to the configuration mode selected. This mode is selected when X1 - X4 is open-circuit.

### Automatic reset connection.

The input has to be closed in order to activate the unit after input/inputs are made according to the configuration mode selected. This mode is selected when a connection between X1 and X4 is made.

### Test.

Test contacts of contactors can be connected between S53 and X1 for supervision.

## Electrical connection – JSBRT11

### SINGLE CHANNEL \*, 1 NO from +24V



### DUAL CHANNEL\*, 2 NO from +24V

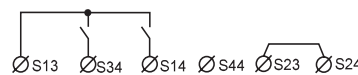

It is recommended that all switched loads are adequately suppressed and/or fused in order to provide additional protection for the safety contacts.

### DUAL CHANNEL\*, 1 NO, 1 NC from +24V

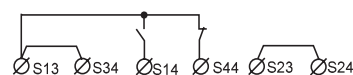

### DUAL CHANNEL\*, 1 NO from +24V, 1 NO from 0V

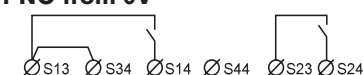

\* With the input conditions shown, the JSBRT11 is in its de-energized state, i.e. output contacts are open.

### Supervised manual reset

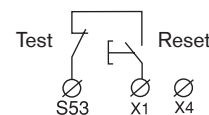

### Automatic reset

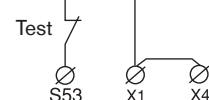

# Safety relay

# JSBR4

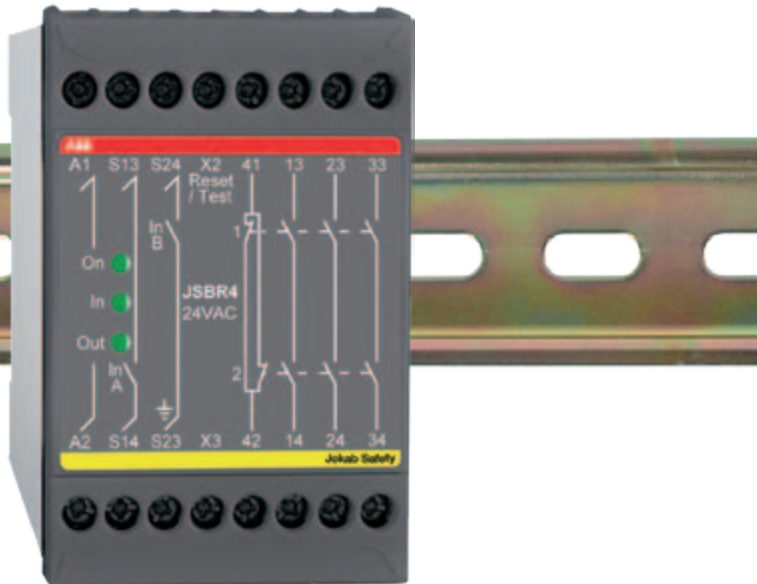

## Approvals:



## Safety relay for:

- Two-hand devices of type IIIc
- Emergency stop
- Three position devices
- Interlocked Gates/Hatches
- Contact strips
- Safety mats
- Foot operated switches

## Features:

- Two channel with concurrency requirement of 0,5 s
- Supervised reset
- Test input
- Width 45 mm
- LED indication for supply, inputs and outputs
- 3 NO/1NC relay outputs
- Supply 24 VDC, 24, 48, 115 or 230 VAC
- Quick release connector blocks

### A universal relay for two-hand- and many other safety devices

The JSBR4 has two inputs, which both have to be closed to keep the safety output contacts closed. A short-circuit across the inputs will cause the output contacts to open. The inputs can however be subjected to a continuous short-circuit without damaging the safety relay.

In order to make the safety outputs close the reset input must be closed and opened. In this way an unintentional reset is prevented in the case of a short-circuit in the reset button cable or if the button gets jammed in the actuated position. The reset input can also be used for test/supervision to ensure that contactors or valves have returned to their initial off/stop position before a new start can be allowed by the safety relay.

When the JSBR4 is used as a two-hand device relay, both buttons have to be pressed within 0.5 seconds of each other in order to close the outputs.

When the JSBR4 is used for Safety Mats and Safety Strips the "stop" condition is given following detection of a short-circuit between input channels A and B. The safety mat, safety strip or the relay will not be damaged by a continuous short-circuit. This also gives the advantage that if there is a failure between the inputs in the installation, the safety relay will not be damaged.

### Safety level

The JSBR4 has a twin supervised safety function. Component failure, short-circuit or external disturbance (e.g. loss of power supply) will not prevent the safe function of the relay. This is valid both for the inputs A and B as well as for the reset input. The JSBR4 operates at the highest safety level for safety relays (PL e according to EN ISO 13849-1).

### Regulations and standards

The JSBR4 is designed and approved in accordance with appropriate directives and standards. See technical data. The JSBR4 complies with the highest safety level for the connection of a two-hand device of type IIIc in accordance with EN 574.

### Connection examples

For examples of how our safety relays can solve various safety problems, please see the section "Connection examples".

## Technical data – JSBR4

<b>Manufacturer</b>	ABB AB/Jokab Safety, Sweden
<b>Article number/Ordering data</b>	2TLA010002R0000 24 DC 24 AC 115 AC 230 AC
<b>Colour</b>	Black and beige
<b>Power supply</b>	24 VDC ± 15% 24/48/115/230 VAC ± 15%, 50 - 60 Hz
<b>Power consumption</b>	1,3 W/3,3 VA
<b>Relay Outputs</b>	3 NO + 1 NC
<b>Max. switching capacity</b>	Resistive load AC Inductive load AC Resistive load DC Inductive load DC
<b>Max. res. load total switching capacity:</b>	12A distributed on all contacts
<b>Min. load</b>	10mA/10 V (if load on contact has not exceeded 100 mA)
<b>Contact material</b>	Ag + Au flash
<b>Fuses Output (External)</b>	5A gL/gG
<b>Conditional short-circuit current (1 kA)</b>	6A gG
<b>Max. Input wire res. at nom. voltage</b>	300 Ohm (S13 - S14 and S23 - S24)
<b>Response time at deactivation</b>	< 20 ms (145 ms at power loss)

<b>Terminals (Max. screw torque 1 Nm)</b>	Single strand: 1 x 2,5 mm <sup>2</sup> /2 x 1 mm <sup>2</sup> . Conductor with socket contact: 1 x 4 mm <sup>2</sup> /2 x 1,5 mm <sup>2</sup> .
<b>Mounting</b>	35 mm DIN-rail
<b>Protection class enclosure/terminals</b>	IP 40/20 IEC 60529
<b>Operating temperature range</b>	-10°C to +55°C (with no icing or condensation)
<b>Impulse Withstand Voltage</b>	2.5kV
<b>Pollution Degree</b>	2
<b>Operating humidity range</b>	35% to 85%
<b>LED indication</b>	Electrical Supply, Inputs, Outputs
<b>Weight</b>	350 g (24 VDC), 460 g (24-230 VAC)
<b>Values (With Proof test interval 1 year)</b>	Safety Category 4 according to EN 954-1, PL e, SIL 3, PFH <sub>d</sub> 1.35E-08
<b>Conformity</b>	2006/42/EC, 2006/95/EC, 2004/108/EC EN 954-1:1996, EN 62061:2005 EN ISO 13849-1:2008

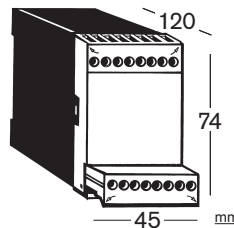

Connector blocks are detachable (without cables having to be disconnected)

## Technical description – JSBR4

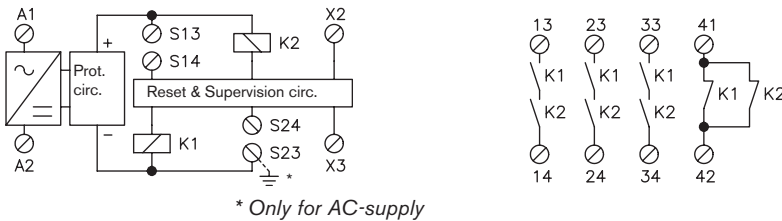

The electrical supply is connected across A1 and A2. After Voltage reduction and Rectification (AC-versions) or reverse polarity protection (DC-version) there is an overload protection-circuit.

When the inputs S13-S14 and S23-S24 have closed and the reset is made, the relays K1 and K2 are activated. A dual stop signal is given when K1 and

K2 drop, due to short circuiting between the inputs, opening of the inputs or power failure. If one input is opened the other input must also be opened for K1 and K2 to be activated again.

The monitoring circuit checks K1 and K2 and that the reset circuit to X2 is both closed and opened before K1 and K2 are energized. Both the stop and reset function therefore comply

with the requirement that a component fault, short circuit or external interference do not result in a dangerous function.

The safety outputs consist of contacts from K1 and K2 connected internally in series across terminals 13 - 14, 23 - 24 and 33 - 34. These contacts are used to cut the power to components which stop or prevent hazardous movements/functions. It is recommended that all switched loads are adequately suppressed and/or fused in order to provide additional protection for the safety contacts.

**Note:** Output 41-42 is intended for indication purposes only, e.g. gate opened. No load between S14 and S24 allowed.

## Electrical connection – JSBR4

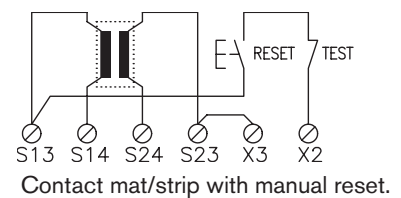
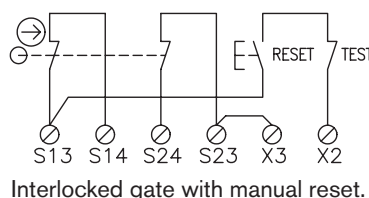
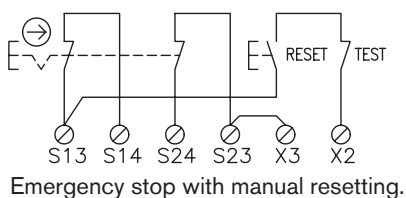

Two hand device with buttons in separate or same enclosure. Buttons to be pressed in within 0.5 s of each other. Footpedal switches can be connected in the same configuration.

Enabling device, JSHD4. Stop condition is given in both top and bottom PB positions.

Control and supervision of external conductor, relay, valve or ABB Jokab Safety's expansion relays.

# Safety relay

# JSBT4

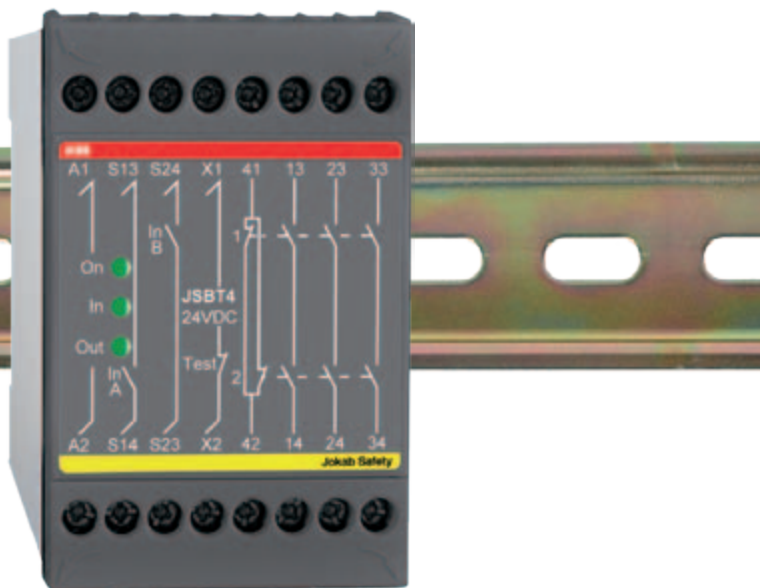

## Safety relay with synchronised dual input channels (within 0.5s)

The JSBT4 has two inputs, both of which have to be closed in order to keep the safety output contacts closed. A short circuit between inputs A and B will cause the output contacts to open. The inputs can be continuously short circuited without damaging the safety relay.

For the outputs to close, the test input must be closed. The test input is intended to monitor that contactors or valves have dropped/returned before a new start is permitted.

This test input must not be confused with the reset function required for gates that a person can walk through and where there is a high safety requirement (see JSBR4).

If the JSBT4 is used for safety Mats and safety Strips, the "stop" condition is given following detection of a short circuit. The safety mat, safety strip or the relay will not be damaged by a continuous short-circuit. This also provides the advantage that if there is a failure between inputs A and B in the installation, the safety relay will not be damaged.

## Safety level

The JSBT4 has a twin supervised safety function. Component failure, short-circuit or external disturbance (e.g. loss of power supply) will not prevent the safe function of the relay. Safety category level 3 or 4, depending on use.

The true two-channel safety function has the advantage that the cabling installation demands for safety can be reduced, due to the fact that a short-circuit between the inputs will directly open the relay's safety outputs.

## Approvals:



## Safety relay for:

- Emergency stops
- Three position devices
- Interlocked Hatches
- Safety mats
- Contact strips
- Foot operated switches

## Features:

- Dual input channels synchronism 0.5 s
- Test input
- Width 45 mm
- LED indications for power on, inputs and outputs
- 3 NO/1NC relay outputs
- Supply 24 VDC, 24, 48, 115 or 230 VAC
- Quick release connector blocks

## Regulations and standards

The JSBT4 is designed and approved in accordance with appropriate directives and standards. See technical data.

## Connection examples

For examples of how our safety relays can solve various safety problems, please see the section "Connection examples".



## Technical data – JSBT4

<b>Manufacturer</b>	ABB AB/Jokab Safety, Sweden
<b>Article number/Ordering data</b> 24 DC	2TLA010004R0000
<b>Colour</b>	Grey
<b>Power supply</b>	24 VDC ± 15% 24/48/115/230VAC ± 15%, 50 - 60 Hz
<b>Power consumption</b>	1.6 W/3.8 VA
<b>Relay Outputs</b>	3 NO + 1 NC
<b>Max. switching capacity</b>	Resistive load AC Inductive load AC Resistive load DC Inductive load DC
	6A/250 VAC/1500 VA AC15 240VAC 2A 6A/24 VDC/150 W DC13 24VDC 1A
<b>Max. res. load total switching capacity:</b>	12A distributed on all contacts
<b>Min. load</b>	10mA/10 V (if load on contact has not exceeded 100 mA)
<b>Contact material</b>	Ag + Au flash
<b>Fuses Output (External)</b>	5A gL/gG
<b>Conditional short-circuit current (1 kA)</b>	6A gG
<b>Max. Input wire res. at nom. voltage</b>	300 Ohm (S13 - S14 and S23 - S24)
<b>Response time at deactivation</b>	< 20 ms, 145 ms with switched supply/power loss

<b>Terminals (Max. screw torque 1 Nm)</b>	Single strand: Conductor with socket contact:	1 x 4 mm <sup>2</sup> /2 x 1,5 mm <sup>2</sup> 1 x 2,5 mm <sup>2</sup> /2 x 1 mm <sup>2</sup>
<b>Mounting</b>		35 mm DIN-rail
<b>Protection class enclosure/terminals</b>		IP 40/20 IEC 60529
<b>Operating temperature range</b>		-10°C to +55°C (with no icing or condensation)
<b>Impulse Withstand Voltage</b>		2.5kV
<b>Pollution Degree</b>		2
<b>Operating humidity range</b>		35% to 85%
<b>LED indication</b>		Electrical Supply, Inputs, Outputs
<b>Weight</b>		350 g (24VDC), 460 g (24-230VAC)
<b>Values (With Proof test interval 1 year)</b>		Safety Category 4 according to EN 954-1, PL e, SIL 3, PFH <sub>d</sub> 1.51E-08
<b>Conformity</b>		2006/42/EC, 2006/95/EC, 2004/108/EC EN 954-1:1996, EN 62061:2005 EN ISO 13849-1:2008

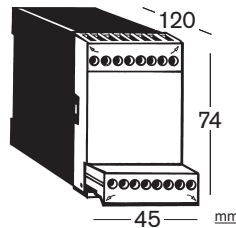

Connector blocks are detachable (without cables having to be disconnected)

## Technical description – JSBT4

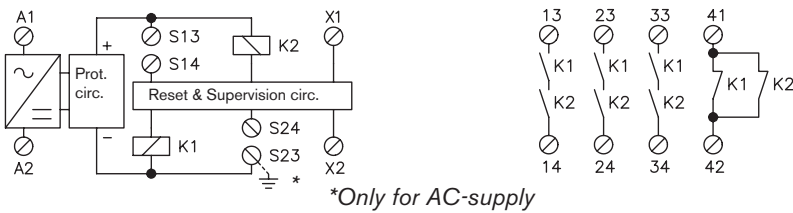

The electrical supply is connected across A1 and A2. After Voltage reduction and Rectification (AC-versions) or reverse polarity protection (DC-version) there is an overload protection-circuit.

When the inputs S13-S14 and S23-S24 are closed within 0.5 seconds of each other the relays K1 and K2 are energized. A dual stop signal is given, K1 and K2 de-energize, when there is a short circuit between or an opening of the inputs or at power loss. If one

input is opened the other one also has to be opened in order to activate K1 and K2 again. The test circuit, X1 - X2, has to be closed in order to activate the outputs, thereafter the test circuit can be opened or closed continuously. If the test circuit is closed after the inputs there is no requirement to close them within 0.5 seconds of each other.

The internal supervision circuit monitors the two Inputs and relays K1, K2. The stop function then fulfils the requirement that one

failure (short circuit, component, external disturbance) shall not prevent the safe function of the JSBT4.

The safety outputs consist of contacts from K1 and K2 connected internally in series across terminals 13 - 14, 23 - 24 and 33 - 34. These contacts are used to cut the power to components which stop or prevent hazardous movements/functions. It is recommended that all switched loads are adequately suppressed and/or fused in order to provide additional protection for the safety contacts.

The NC output 41 - 42 should only be used for monitoring purposes e.g. Indication lamp or PLC input etc. The output contacts are closed until the module is reset.

**Note:** Output 41-42 is intended for indication purposes only, e.g. gate opened. No load between S14 and S24 allowed.

## Electrical connection – JSBT4

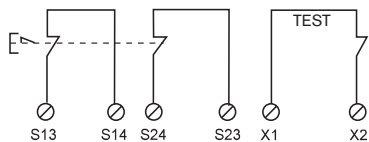

Emergency stop with automatic resetting.

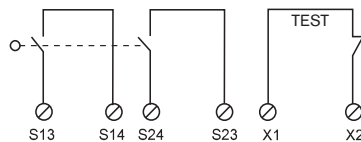

Interlocked hatch with automatic resetting.

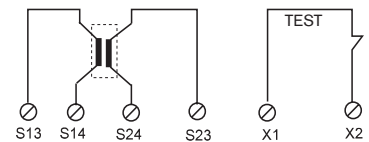

Contact mat/strip with automatic reset

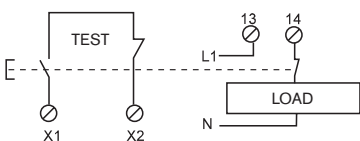

Monitoring to ensure that the Start button cannot stick in pressed position. Short circuiting over the closing contact is not monitored. The RT-series and JSBR4 have built in short circuiting monitored resetting.

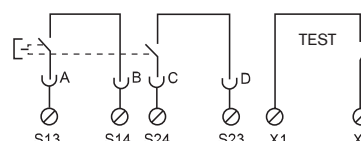

Enabling device, JSBD4. Stop condition is given in both top and bottom positions.

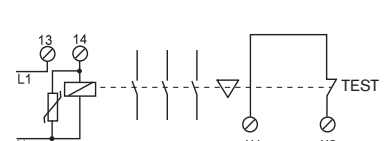

Control and supervision of external contactor, relay, valve or ABB Jokab Safety's expansion relays.

# Safety relay/expansion relay

# BT50(T)



## Safety relay/expansion relay to Pluto

The BT50 is designed to connect safety devices, such as emergency stops, directly in the voltage supply circuit to the relay. Despite a maximum built-in width of 22.5 mm the relay is very powerful.

With 3NO safety outputs, 1NC output (for monitoring purposes), a test input and complete internal supervision, the BT50 is quite unique. In addition, delayed outputs (BT50T) can be ordered.

In order for the safety outputs to close, the supply voltage, e.g. by means of an emergency stop button, must be connected to A1 and A2 and the test input closed. After actuation of the relay the test input can be opened again.

The test input is intended to supervise that contactors or valves have dropped/returned before a new start can be permitted. The test input can also be used for starting and the start button can be supervised (see the connection example on the next page).

## More outputs

By connecting a BT50 to a safety relay/PLC it is easy to increase the number of safe outputs. This means that an unlimited number of dangerous machine operations and functions can be stopped by using just one safety-PLC.

## Safety level

BT50 have an internal redundant and monitored safety function. Power failure, internal component faults or external interference cannot result in dangerous functions.

Input via A1 on its own is not protected from short

## Approvals:



## Safety relay for:

Emergency stop  
Interlocked hatch  
Expansion of Pluto

## Features:

Single and "dual" channel  
Test/"reset" input  
Width 22.5 mm  
LED indication  
3 NO/1NC relay outputs  
Supply 24 VDC  
Quick release connector blocks  
BT50 - Additional power terminals  
BT50T - One changeover relay with a double information output (Y14)  
BT50T - Delay times selectable from 0 - 1.5 s

circuiting, and therefore installation is critical for the safety level to be achieved. To achieve a higher safety level a screened cable can be used and/or connection made to both A1 and A2 (see the example on the next page).

## Regulations and standards

The BT50 is designed and approved in accordance with appropriate directives and standards. See technical data.

## Connection examples

For examples of how our safety relays can solve various safety problems, please see the chapter "Connection examples".



## Technical data – BT50(T)

<b>Manufacturer</b>	ABB AB/Jokab Safety, Sweden
<b>Article number/Ordering data</b> BT50 BT50T	2TLA010033R0000 2TLA010033R1000
<b>Colour</b>	Black and beige
<b>Operational voltage</b>	24 VDC + 15%/-25%
<b>Power consumption</b>	1,4 W/1,8 W
<b>Relay Outputs</b>	3 NO + 1 NC
<b>Max. switching capacity</b> Resistive load AC Inductive load AC Resistive load DC Inductive load DC	6A/250 VAC/1500 VA AC15 240VAC 2A 6A/24 VDC/150 W DC13 24VDC 1A
<b>Max. res. load total switching capacity:</b>	12A distributed on all contacts
<b>Min. load</b>	10mA/10 V(if load on contact has not exceeded 100 mA)
<b>Contact material</b>	Ag + Au flash
<b>Fuses Output (External)</b>	5A gL/gG
<b>Conditional short-circuit current (1 kA)</b>	6A gG
<b>Max Input Wire res. at nom. voltage</b>	200 Ohms
<b>Response time at deactivation (input - output)</b>	Version B <20 ms or delayed max 1500 ms (old version of BT50 <60 ms)

<b>Terminals (Max. screw torque 1 Nm)</b> Single strand: Conductor with socket contact:	2x1.5 mm <sup>2</sup> 2x1mm <sup>2</sup> .
<b>Mounting</b>	35 mm DIN-rail
<b>Protection class enclosure/terminals</b>	IP 40/20 IEC 60529
<b>Impulse Withstand Voltage</b>	2.5kV
<b>Pollution Degree</b>	2
<b>Operating temperature range</b>	-10°C to +55°C (with no icing or condensation)
<b>Operating humidity range</b>	35% to 85%
<b>LED indication</b>	Electrical Supply, Relay and X4
<b>Weight</b>	200 g
<b>Performance (max.)</b> Functional test: The relays must be cycled at least once a year.	Category 4/PL e (EN ISO 13849-1:2008) SIL 3 (EN 62061:2005) PFH <sub>d</sub> 1.22E-08
<b>Conformity</b>	2006/42/EC, 2006/95/EC, 2004/108/EC EN 954-1:1996, EN 62061:2005 EN ISO 13849-1:2008

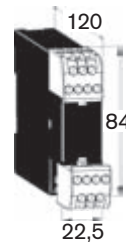

Connector blocks are detachable (without cables having to be disconnected)

## Technical description – BT50(T)

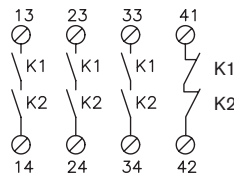
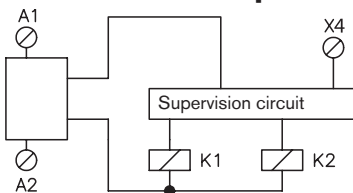

When supply voltage is connected to A1 and A2, relays K1 and K2 are activated. K1 and K2 drop if the supply voltage is disconnected. Both relays K1 and K2 must drop for them to be activated again. Another requirement is that the test circuit, A1 - X4, must be closed for the outputs to be activated. Thereafter A1 - X4 can either be open or constantly closed.

The supervising circuit ensures that both K1 and K2 have dropped before they can be reactivated. The stop function complies with the requirement that a component fault

or external interference cannot lead to a dangerous function.

The safety outputs consist of contacts from K1 and K2 connected internally in series across terminals 13 - 14, 23 - 24, and 33 - 34. These contacts are used to cut the power to components which stop or prevent hazardous movements/functions. It is recommended that all switched loads are adequately suppressed and/or fused in order to provide additional protection for the safety contacts.

The NC output 41 - 42 should only be used for monitoring purposes e.g. indication lamp for emergency stop pressed.

### BT50T - Info. output

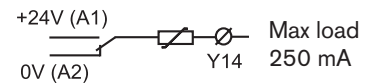

### BT50T - Delay times

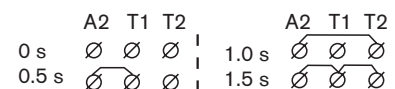

## Electrical connection – BT50(T)

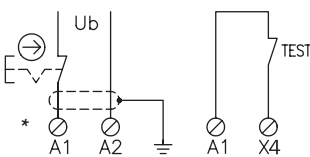

Emergency stop with reset when emergency button returns.

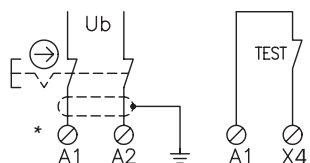

Emergency stop with dual connection direct to the supply voltage.

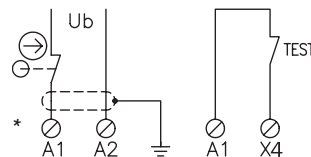

Hatch with automatic reset.

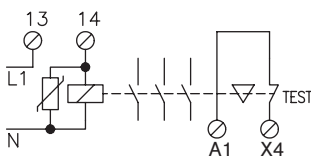

Controlled monitoring of external contactor, relay, valve or ABB Jokab Safety's expansion relays.

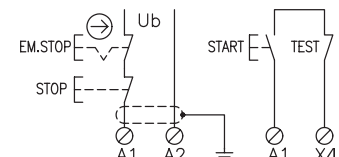

BT50 as emergency stop and control relay with Start and Stop function.

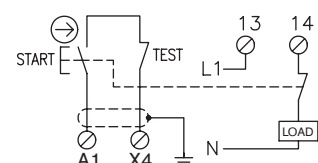

Monitoring to ensure that the On button is not stuck in pressed position. A short circuit over the closing contact is not monitored.

\* BT50 has additional power terminals A1 and A2.

# Safety relay/expansion relay

# BT51(T)



## Approvals:



## Safety relay for:

Emergency stop  
Interlocked hatch  
Expansion of Pluto

## Features:

Single and "dual" channel  
Test/"reset" input  
Width 22.5 mm  
LED indication  
4 NO relay outputs  
Supply 24 VDC  
Quick release connector blocks  
BT51 - Additional power terminals  
BT51T - One changeover relay with a double information output (Y14)  
BT51T  
Delay times selectable from 0 - 1.5 s

### Safety relay/expansion relay to Pluto

The BT51 is designed to connect safety devices, such as emergency stops, directly in the voltage supply circuit to the relay. Despite a maximum built-in width of 22.5 mm the relay is very powerful.

With 4 NO safety outputs, test input and complete internal supervising, the BT51 is quite unique. In addition you can order delayed outputs (BT51T).

In order for the safety outputs to close, the supply voltage, e.g. by means of an emergency stop button, must be connected to A1 and A2 and the test input closed. After actuation of the relay the test input can be opened again.

The test input is intended to supervise that contactors or valves have dropped/returned before a new start can be permitted. The test input can also be used for starting and the start button can be supervised (see connection example on next page).

### More outputs

By connecting BT51 to a safety relay/PLC it is easy to increase the number of safe outputs. This means that an unlimited number of dangerous machine operations and functions can be stopped from one safety relay/PLC.

### Safety level

BT50 have an internal redundant and monitored safety function. Power failure, internal component faults or external interference cannot result in dangerous functions.

Input via A1 only is not protected from short circuiting, and therefore installation is critical for the safety level to be achieved. To achieve a higher safety level a screened cable can be used and/or connection made to both A1 and A2 (see example overleaf).

### Regulations and standards

The BT51 is designed and approved in accordance with appropriate directives and standards. See technical data.

### Connection examples

For examples of how our safety relays can solve various safety problems, please see the chapter "Connection examples".

## Technical data – BT51(T)

<b>Manufacturer</b>	ABB AB/Jokab Safety, Sweden
<b>Article number/Ordering data</b> BT51 BT51T	2TLA010033R2000 2TLA010033R3000
<b>Colour</b>	Grey
<b>Operational voltage</b>	24 VDC + 15%/-25%
<b>Power consumption</b>	1.4 W/1.8 W
<b>Relay Outputs</b>	4 NO
<b>Max. switching capacity</b> Resistive load AC Inductive load AC Resistive load DC Inductive load DC	6A/250 VAC/1500 VA AC15 240VAC 2A 6A/24 VDC/150 W DC13 24VDC 1A
<b>Max. res. load total switching capacity:</b>	12 A distributed on all contacts
<b>Min. load</b>	10mA/10 V (if load on contact has not exceeded 100 mA)
<b>Contact material</b>	Ag + Au flash
<b>Fuses Output (External)</b>	5A gL/gG
<b>Conditional short-circuit current (1 kA)</b>	6A gG
<b>Max Input Wire res. at nom. voltage</b>	200 Ohms
<b>Response time at deactivation</b>	<20 ms or delayed max 1500 ms (BT51T)
<b>Terminals (Max. screw torque 1 Nm)</b> Single strand: Conductor with socket contact:	2x1.5 mm <sup>2</sup> 2x1mm <sup>2</sup>

<b>Mounting</b>	35 mm DIN-rail
<b>Protection class enclosure/ terminals</b>	IP 40/20 IEC 60529
<b>Impulse Withstand Voltage</b>	2.5kV
<b>Pollution Degree</b>	2
<b>Operating temperature range</b>	-10°C to +55°C (with no icing or condensation)
<b>Operating humidity range</b>	35% to 85%
<b>LED indication</b>	Electrical Supply, Relay and X4
<b>Weight</b>	200 g
<b>Performance (max.)</b> Functional test: The relays must be cycled at least once a year.	Category 4/PL e (EN ISO 13849-1:2008) SIL 3 (EN 62061:2005) PFH <sub>d</sub> 1.63E-08
<b>Conformity</b>	2006/42/EC, 2006/95/EC, 2004/108/EC EN 954-1:1996, EN 62061:2005 EN ISO 13849-1:2008

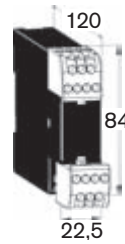

Connector blocks are detachable (without cables having to be disconnected)

## Technical description – BT51(T)

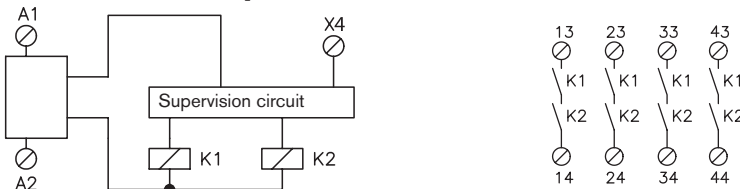

When supply voltage is connected to A1 and A2, relays K1 and K2 are activated. K1 and K2 drop if the supply voltage is disconnected. Both relays K1 and K2 must drop for them to be activated again. Another requirement is that the test circuit, A1 - X4, must be closed for the outputs to be activated. Thereafter A1 - X4 can either be open or constantly closed.

The supervising circuit ensures that both K1 and K2 have dropped before they can be reactivated. The stop function complies with the requirement that a component fault

or external interference cannot lead to a dangerous function.

The safety outputs consist of contacts from K1 and K2 connected internally in series across terminals 13 - 14, 23 - 24, 33 - 34 and 43 - 44. These contacts are used to cut the power to components which stop or prevent hazardous movements/functions. It is recommended that all switched loads are adequately suppressed and/or fused in order to provide additional protection for the safety contacts.

### BT51T - Info. output

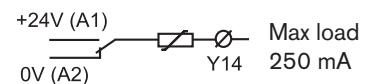

### BT51T - Delay times

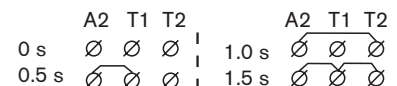

## Electrical connection – BT51(T)

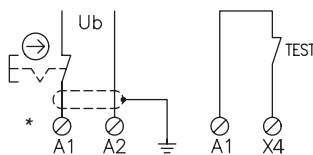

Emergency stop with reset when emergency button returns.

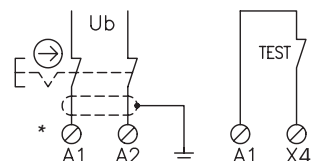

Emergency stop with dual connection direct to the supply voltage.

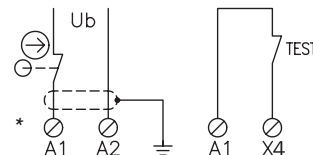

Hatch with automatic reset.

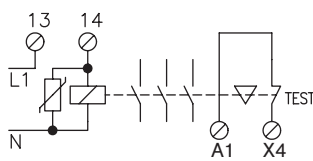

Controlled monitoring of external contactor, relay, valve or ABB Jokab Safety's expansion relays.

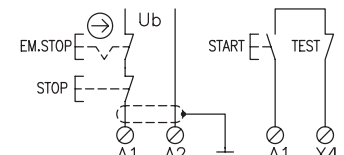

BT51 as emergency stop and control relay with Start and Stop function.

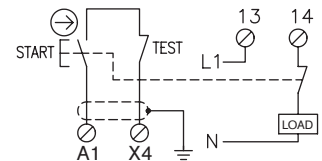

Monitoring to ensure that the On button is not stuck in pressed position. A short circuit over the closing contact is not monitored.

\* BT51 has additional power terminals A1 and A2.

## Safety relay

# JSBT5(T)



### Approvals:



### Safety relay for:

Emergency stop  
Interlocked hatch

### Features:

Single and “dual” channel  
Test/start input  
Width 22.5 mm  
LED indication  
3 NO/1NC relay outputs  
(T) = delayed outputs  
0.5 sec.  
Supply 12 VDC, 24 VDC/  
AC

### Single channel safety relay

The JSBT5 is designed to connect safety devices, such as emergency stops, directly in the voltage supply circuit to the relay. Despite a maximum built-in width of 22.5 mm the relay is very powerful.

With 3 NO safety outputs, 1 NC, test input and complete internal supervising, the JSBT5 is quite unique. In addition you can order delayed outputs (JSBT5T).

In order for the safety outputs to close, the supply voltage, e.g. by means of an emergency stop button, must be connected to A1 and A2 and the test input closed. After actuation of the relay the test input can be opened again.

The test input is intended to supervise that contactors or valves have dropped/returned before a new start can be permitted. The test input can also be used for starting and the start button can be supervised (see connection example on next page).

### Safety level

The JSBT5 has a twin and supervised internal safety function. Power failure, internal component faults or external interference cannot result in dangerous functions.

Input via A1 only is not protected from short circuiting, and therefore installation is critical for the safety level to be achieved. To achieve a higher safety level a screened cable can be used and/or connection made to both A1 and A2 (see example overleaf).

### Regulations and standards

The JSBT5 is designed and approved in accordance with appropriate directives and standards. See technical data.

### Connection examples

For examples of how our safety relays can solve various safety problems, please see the section “Connection examples”.

## Technical data – JSBT5(T)

<b>Manufacturer</b>	ABB AB/Jokab Safety, Sweden
<b>Article number/Ordering data</b>	JSBT5 24 AC/DC JSBT5 12 VDC JSBT5T 24 AC/DC
	2TLA010005R0100 2TLA010005R0700 2TLA010005R1100
<b>Colour</b>	Grey
<b>Operational voltage</b>	JSBT5: JSBT5T:
	24 VDC/AC + 15%–25%, 50–60 Hz 12 VDC, 24 VDC/AC + 15% – 25%, 50 - 60 Hz
<b>Power consumption</b>	1 W/1.9 VA
<b>Relay Outputs</b>	3 NO + 1 NC
<b>Max. switching capacity</b>	Resistive load AC Inductive load AC Resistive load DC Inductive load DC
	6A/250 VAC/1500 VA AC15 240VAC 2A 6A/24 VDC/150 W DC13 24VDC 1A
<b>Max. res. load total switching capacity:</b>	9A distributed on all contacts
<b>Min. load</b>	10mA/10 V (if load on contact has not exceeded 100 mA)
<b>Contact material</b>	AgCuNi
<b>Fuses Output (External)</b>	5A gL/gG
<b>Conditional short-circuit current (1 kA)</b>	6A gG
<b>Max Input Wire res. at nom. voltage</b>	200 Ohm
<b>Response time at deactivation</b>	<60 ms or delayed max 500 ms (JSBT5T)

<b>Terminals (Max. screw torque 1 Nm)</b>	Single strand: Conductor with socket contact:
	2x1.5 mm <sup>2</sup> 2x1mm <sup>2</sup>
<b>Mounting</b>	35 mm DIN-rail
<b>Protection class enclosure/ terminals</b>	IP 40/20 IEC 60529
<b>Impulse Withstand Voltage</b>	2.5kV
<b>Pollution Degree</b>	2
<b>Operating temperature range</b>	-10°C to +55°C (with no icing or condensation)
<b>Operating humidity range</b>	35% to 85%
<b>Function indication</b>	Electrical Supply
<b>Weight</b>	200 g
<b>Performance (max.)</b>	Category 4/PL e Functional test: The relays must be cycled at least once a year.
	(EN ISO 13849-1:2008) SIL 3 (EN 62061:2005) PFH <sub>d</sub> 1.22E-08
<b>Conformity</b>	2006/42/EC, 2006/95/EC, 2004/108/EC EN 954-1:1996, EN 62061:2005 EN ISO 13849-1:2008

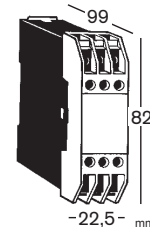

## Technical description – JSBT5(T)



When supply voltage is connected to A1 and A2, relays K1 and K2 are activated. K1 and K2 drop if the supply voltage is disconnected. Both relays K1 and K2 must drop for them to be activated again. Another requirement is that the test circuit, X1 - X2, must be closed for the outputs to be activated. Thereafter X1 - X2 can either be open or constantly closed.

The supervising circuit ensures that both K1 and K2 have dropped before they can

be reactivated. The stop function complies with the requirement that a component fault or external interference cannot lead to a dangerous function.

The safety outputs consist of contacts from K1 and K2 connected internally in series across terminals 13 - 14, 23 - 24, and 33 - 34. These contacts are used to cut the power to components which stop or prevent hazardous movements/functions.

It is recommended that all switched loads are adequately suppressed and/or fused in order to provide additional protection for the safety contacts.

The NC output 41 - 42 should only be used for monitoring purposes e.g. indication lamp for emergency stop pressed.

## Electrical connection – JSBT5(T)

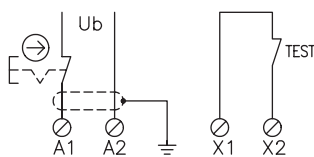

Emergency stop with automatic reset when emergency button returns.

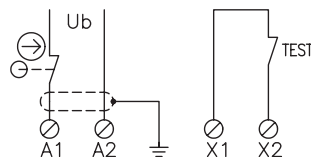

Hatch with automatic reset.

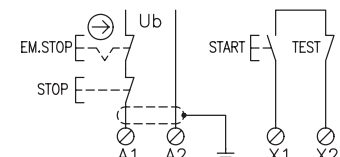

JSBT5 as emergency stop and control relay with Start and Stop function.

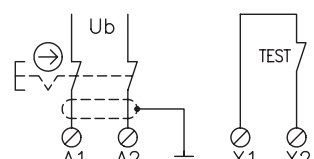

Emergency stop with dual connection direct to the supply voltage.

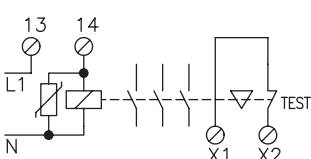

Controlled monitoring of external contactor, relay, valve or ABB Jokab safety's expansion relays.

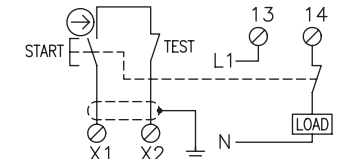

Monitoring to ensure that the On button is not stuck in pressed position. A short circuit over the closing contact is not monitored. The JSBR4 has built in short circuit monitored resetting.



# Safety timer

# JSHT1

## Approvals:



## Safety timer for:

- Time reset
- Time bypassing

## Features:

- Hardwire time selection  
5 – 40 s
- Selectable single or dual channel input
- Test input
- Width 45 mm
- LED indication for supply, inputs and outputs
- 1+1 NO relay outputs
- Supply 24 VDC, 24, 48, 115 or 230 VAC
- Quick release connector blocks

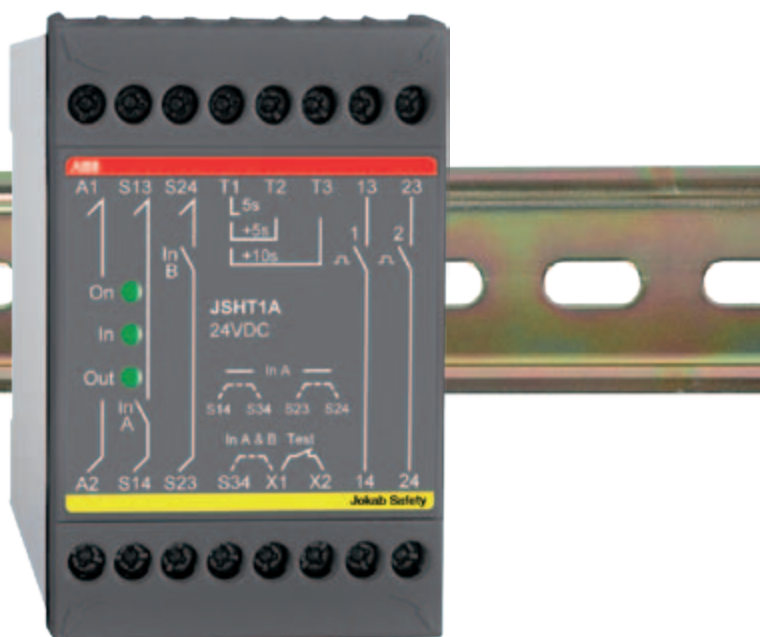

**The JSHT1A/B closes two independent relay outputs during a guaranteed maximum time when the inputs are opened.**

### Time reset

Time reset can prevent unintentional reset of safety systems when someone is still in the dangerous area of the machine. During a guaranteed maximum time, one or several PB's for reset must be activated. The reset buttons should be sited in such a way that operatives have a clear overview of the whole area which is guarded. Time reset is made by the combination of a safety relay and the timer relay JSHT1A/B.

### Time bypassing

The JSHT1 can also be used for time bypass of light beams for e.g. autotruck into a dangerous area.

### Operation

When the inputs open the output contacts close. The output contacts open when the inputs close or when the time period has expired. The time period is hardwire selectable on terminals T1, T2 and T3. The time given is the maximum time. One or two channel operation is also hardwire selectable.

### Regulations and standards

The JSHT1A/B is designed and approved in accordance with appropriate directives and standards. See technical data.

### Connection examples

For examples of how our safety relays can solve various safety problems, please see the section "Connection examples".

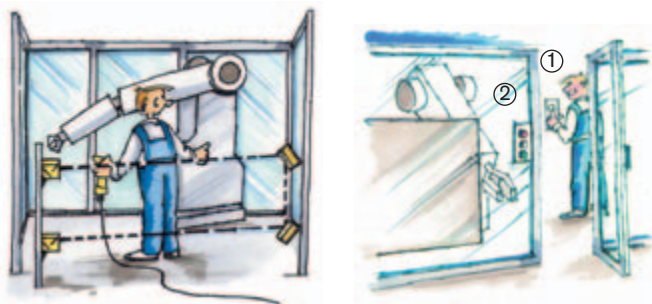

*Light beam being bypassed for a maximum pre-set time e.g. 5 sec. by the JSHT1 during entrance and exit with the JSHD4 Three Position Enabling device.*

*Time reset procedure. First push PB1, then exit dangerous area and close the door, then push PB2 (PB1 and PB2 must be pressed within the predetermined time period selected). After this procedure the machine can be safely restarted.*



## Technical data – JSHT1 A/B

<b>Manufacturer</b>	ABB AB/Jokab Safety, Sweden
<b>Article number/Ordering data</b> JSHT1A 24 DC JSHT1B 24 DC	2TLA010011R0000 2TLA010011R1000
<b>Colour</b>	Grey
<b>Power supply</b>	24 VDC ± 15 %, 24/48/115/230 VAC ± 15 %, 50 - 60 Hz (AC versions JSHT1A only)
<b>Power consumption</b>	1.8 W/3.7 VA
<b>Max Input Wire res. at nom voltage/channel</b>	100/200 Ohm (1 Channel/ 2 Channel)
<b>Response time at activation</b>	<30ms
<b>Response time at deactivation</b>	< 15 ms
<b>Selectable time (± 15 % at nom. V.)</b>	JSHT1A: 5-10-15-20 sec JSHT1B: 5-15-30-40 sec
<b>Relay outputs</b>	2 x 1 NO
<b>Max. switching capacity</b>	
<b>Resistive load AC</b>	4A/250 VAC/1000 VA
<b>Inductive load AC</b>	AC15 250VAC 3A
<b>Resistive load DC</b>	4A/24 VDC/100 W
<b>Inductive load DC</b>	DC13 24VDC 2A
<b>Max. total switching capacity:</b>	8A distributed on all contacts
<b>Min. load</b>	10mA/10 V (if load on contact has not exceeded 100 mA)
<b>Contact material</b>	AgCuNi
<b>Fuses Output (External)</b>	3A gL/gG or 4A fast
<b>Conditional short-circuit current (1 kA)</b>	6A gG
<b>Max Input Wire res. at nom. voltage</b>	100 Ohm

<b>Terminals (Max. screw torque 1 Nm)</b>	
Single strand:	1 x 4 mm <sup>2</sup> , 2 x 1,5 mm <sup>2</sup>
Conductor with socket contact:	1 x 2,5 mm <sup>2</sup> , 2 x 1 mm <sup>2</sup>
<b>Mounting</b>	35 mm DIN-rail
<b>Protection class enclosure/ terminals</b>	IP20/IP40 IEC 60529
<b>Impulse Withstand Voltage</b>	2.5kV
<b>Pollution Degree</b>	2
<b>Operating temperature range</b>	-10°C to +55°C (with no icing or condensation)
<b>Operating humidity range</b>	35% to 85%
<b>LED indication</b>	Electrical Supply, Inputs, Outputs
<b>Weight</b>	24 VDC: 330 g 24/48/115/230 VAC: 430 g
<b>Performance (max.)</b>	Category 4 / PL e (EN ISO 13849-1:2008) Functional test: The relays must be cycled at least once a year.
<b>Conformity</b>	2006/42/EC, 2006/95/EC, 2004/108/EC EN 954-1:1996, EN 62061:2005 EN ISO 13849-1:2008

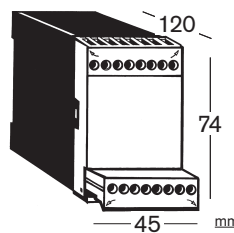

Connector blocks are detachable (without cables having to be disconnected)

## Technical description – JSHT1 A/B

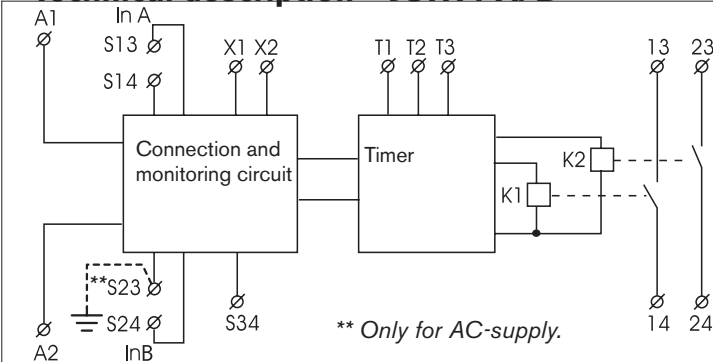

The electrical supply is connected across A1 and A2. The internal supervising circuit is activated directly when the supply is on. The inputs A and B must both be closed and then opened. Thereafter K1 and K2

are activated and the outputs close. K1 and K2 are activated for the hardwired selected time (set by connections on the terminals T1, T2 and T3). If there is a short circuit between the inputs or the inputs

are closed again before the set time period has expired the outputs will open. In order to close the outputs again both the inputs have to be closed and both internal relays K1 and K2 deactivated (controlled by the supervising circuit) and the inputs again opened.

By external hardwire connections the JSHT1 can be made single or dual channel input. See figure below.

## Electrical connection – JSHT1 A/B

### Connection for single channel input

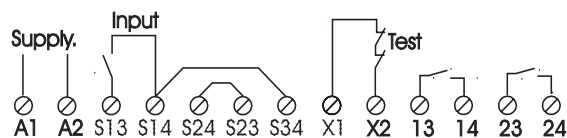

### Selection of time by hardwire links

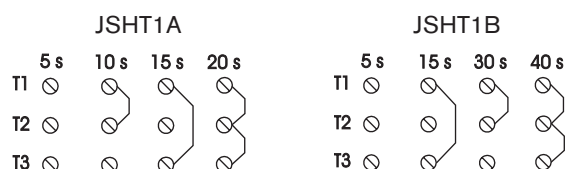

### Connection for dual channel input

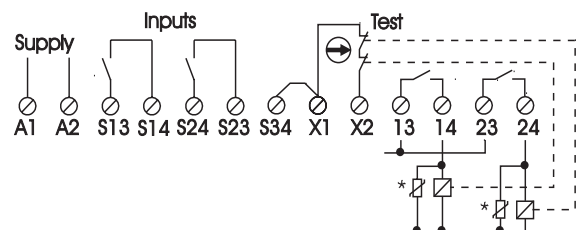

\* It is recommended that all switched loads are adequately suppressed and/or fused in order to provide additional protection for the safety contacts. In the figure the monitoring of two contactors in the test input is shown.

# Safety timer

# JSHT2

## Approvals:



## Safety relay for:

Time bypassing  
Inching

## Features:

- Hardwire time selection  
0.2 – 40 s
- Selectable single or dual channel input
- Test input
- Width 45 mm
- LED indication for supply, inputs and outputs
- 1+1 NO relay outputs
- Supply 24 VDC, 24, 48, 115 or 230 VAC
- Quick release connector blocks

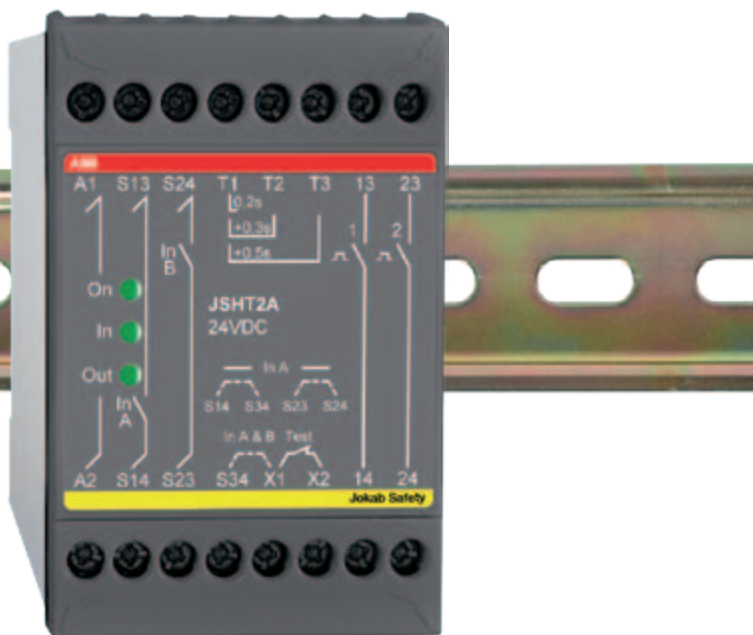

**The JSHT2A/B/C closes two independent relay outputs during a guaranteed maximum period of time when the inputs are closed.**

### Time bypassing

Sensors detect the autocarrier and are connected to the JSHT2 which supervises the sensors and bypasses the light beam for a maximum predetermined time.

### Inching

Inching applications require safety outputs to be closed for a predetermined maximum period of time, allowing the machine to move only a short distance each time the inching control is activated. For each new motion the inching control e.g. PB or pedal must be released and activated again.

### Operation

When the inputs close the output contacts close. The output contacts open when the input opens or when the time period has expired. The time is hardwire selectable on the terminals T1, T2 and T3. The time given is the maximum time. Single or dual channel operation is also hardwire selectable.

### Regulations and standards

The JSHT2A/B/C is designed and approved in accordance with appropriate directives and standards. See technical data.

### Connection examples

For examples of how our safety relays can solve various safety problems, please see the section "Connection examples".

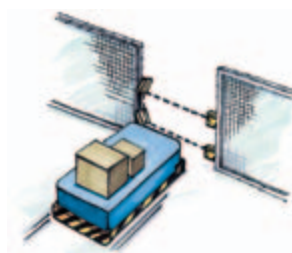

*Light beam being bypassed only for the time it takes the autocarrier to pass.*



*Shaft only turns a small amount each time the PB is pressed.*

Technical data – JSHT2 A/B/C	
<b>Manufacturer</b>	ABB AB/Jokab Safety, Sweden
<b>Article number/Ordering data</b>	JSHT2A 24 DC 2TLA010012R0000 JSHT2B 24 DC 2TLA010012R1000 JSHT2C 24 DC 2TLA010012R2000
<b>Colour</b>	Grey
<b>Power supply</b>	24 VDC ± 15 % 24/48/115/230 VAC ± 15 %, 50 - 60 HZ
<b>Power consumption</b>	1.8 W/3.8 VA
<b>Max Input Wire res. at nom voltage/channel</b>	100/200 Ohm (1 Channel/ 2 Channel)
<b>Response time at activation</b>	< 30 ms
<b>Response time at deactivation</b>	< 15 ms
<b>Selectable time (± 15 % at nom. V.)</b>	JSHT2A: 0.2 - 0.5 - 0.7 - 1.0 sec JSHT2B: 5 - 10 - 15 - 20 sec JSHT2C: 5 - 15 - 30 - 40 sec
<b>Relay outputs</b>	2 x 1 NO
<b>Max. switching capacity</b>	
<b>Resistive load AC</b>	4A/250 VAC/1000 VA
<b>Inductive load AC</b>	AC15 250VAC 3A
<b>Resistive load DC</b>	4A/24 VDC/100 W
<b>Inductive load DC</b>	DC13 24VDC 2A
<b>Max. total switching capacity:</b>	8A distributed on all contacts
<b>Min. load</b>	10mA/10 V (if load on contact has not exceeded 100 mA)
<b>Contact material</b>	AgCuNi
<b>Fuses Output (External)</b>	3A gL/gG or 4A fast
<b>Max Input Wire res. at nom. voltage</b>	100 Ohm

<b>Terminals (Max. screw torque 1 Nm)</b>	Single strand: 1 x 4 mm <sup>2</sup> or 2 x 1,5 mm <sup>2</sup> Conductor with socket contact: 1 x 2,5 mm <sup>2</sup> or 2 x 1 mm <sup>2</sup>
<b>Mounting</b>	35 mm DIN-rail
<b>Protection class enclosure/ terminals</b>	IP 20/IP 40 IEC 60529
<b>Impulse Withstand Voltage</b>	2.5kV
<b>Pollution Degree</b>	2
<b>Operating temperature range</b>	-10°C to +55°C (with no icing or condensation)
<b>Operating humidity range</b>	35% to 85%
<b>LED indication</b>	Electrical Supply, Inputs, Outputs
<b>Weight</b>	24 VDC: 310 g 24/48/115/230 VAC: 410 g.
<b>Performance (max.)</b>	Safety Category 4/PL e (EN ISO 13849-1:2008) SIL 3 (EN 62061:2005) PFH <sub>d</sub> 4.42E-09
<b>Conformity</b>	2006/42/EC, 2006/95/EC, 2004/108/EC EN 954-1:1996, EN 62061:2005 EN ISO 13849-1:2008

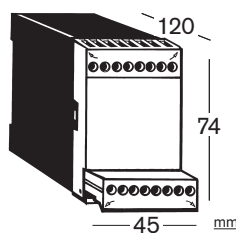

Connector blocks are detachable (without cables having to be disconnected)

## Technical description – JSHT2 A/B/C

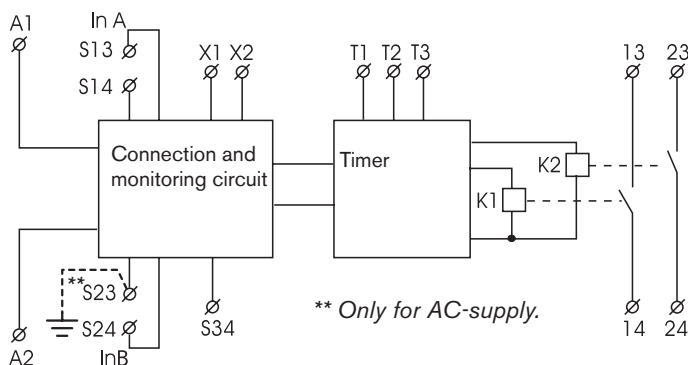

The electrical supply is connected across A1 and A2. The internal supervising circuit is activated directly when the supply is on. The inputs A and B must both be opened and then closed. Thereafter K1 and K2 are activated and the outputs close. K1 and K2 are activated for hardwired selected time

(set by connections on the terminals T1, T2 and T3). If there is a short circuit between the inputs or the inputs are opened again before the set time period has expired the outputs will open. In order to close the outputs again both the inputs have to be opened and both internal relays K1 and

K2 deactivated (controlled by the supervising circuit) and then the inputs closed again.

By external hardwire connectors the JSHT2 can be made to operate from either single or dual channel inputs. See figure below.

## Electrical connection – JSHT2 A/B/C

### Connection for single channel input

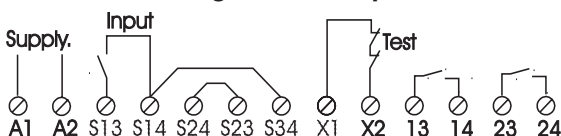

### Connection for dual channel input

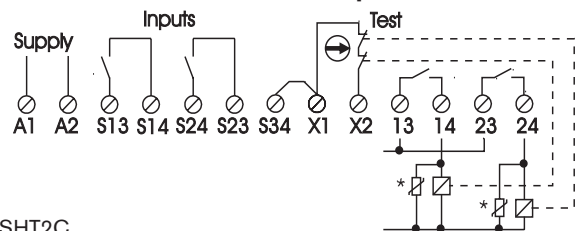

### Selection of time by hardwire links

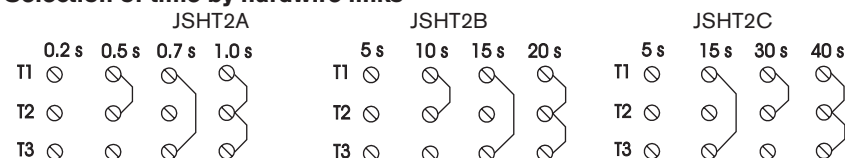

\* It is recommended that all switched loads are adequately suppressed and/or fused in order to provide additional protection for the safety contacts. In the figure the monitoring of two contactors in the test input is shown.

# Expansion relay E1T



## Approvals:



## Expansion relay with:

- More safety outputs
- Delayed safety outputs

## Features:

- Width 22.5 mm
- Supply 24 VDC
- LED output indication
- 4 NO relay outputs
- Single or dual channel operation option
- Quick release connector blocks

### More outputs

By connecting expansion relays to a safety relay it is easy to increase the number of safe outputs. This means that an unlimited number of dangerous machine operations and functions can be stopped from one safety relay.

### Safe soft stop

When a gate is opened a program stop is first given to the machine's PLC/servo which brakes the dangerous operations in a soft and controlled way. The safety outputs then break the power to the motors, that is, when the machine has already stopped. Normally between 0.5 and 1 second is needed to brake a dangerous machine operation softly.

Soft stop ensures many advantages:

- The machine lasts longer.
- Parts being processed are not damaged.
- Restart from stopped position is enabled and simplified.

A safe soft stop is achieved by means of a safety relay which gives the program stop, and an expansion relay, E1T, which gives safe delayed stop signals. See section "Connection examples". The drop time delay on a E1T can as standard be selected from 0 to 3 seconds. By connecting several E1T's in series even longer times can be achieved.

### When are delayed safe stops used?

Delayed safety stop signals can be used for emergency stops according to EN ISO 13850:2008 § 4.1.4. Stop category 1, i.e. a controlled stop with power to the actuator(s) available to achieve the stop and then removal of power when stop is achieved.

Stop category 1 may also be permitted when it is not possible to gain physical access to the machine before the safe stop is affected e.g:

- Gates, access time is normally over 1 sec.
- Covers and gates which are locked until dangerous operations and functions have been stopped.
- Long distances between a safety device and a dangerous machine function.

### Safety level

The E1T has twin stop functions, that is, two relays with mechanically operated contacts. A monitored stop function is achieved by connecting the test output (terminals X1 and X2) to the test or reset input on the safety relay which is being expanded.

One condition for a safe delayed stop is that the delay time cannot increase in the event of a fault. The E1T complies with this requirement.

### Regulations and standards

The E1T is designed and approved in accordance with appropriate directives and standards. See technical data.

### Connection examples

For examples of how our safety relays can solve various safety problems, please see the section "Connection examples".

## Technical data – E1T

<b>Manufacturer</b>	ABB AB/Jokab Safety, Sweden
<b>Article number/Ordering data</b>	E1T 0 s 24DC 2TLA010030R0000 E1T 0,5 s 24DC 2TLA010030R1000 E1T 1 s 24DC 2TLA010030R2000 E1T 1,5 s 24DC 2TLA010030R3000 E1T 2 s 24DC 2TLA010030R4000 E1T 3 s 24DC 2TLA010030R5000
<b>Colour</b>	Grey
<b>Operational voltage</b>	24 VDC ± 15%
<b>Power consumption</b>	1.5 W
<b>Relay Outputs</b>	4 NO
<b>Max. switching capacity</b>	Resistive load AC 6A/250VAC/1500VA Inductive load AC AC15 240VAC 2A Resistive load DC 6A/24VDC/150W Inductive load DC DC13 24VDC 1A
<b>Max. total switching capacity</b>	12A distributed on all contacts
<b>Min. switching load</b>	10 mA/10 V (if load on contact has not exceeded 100 mA)
<b>Contact material</b>	Ag + Au flash
<b>Fuses Output (External)</b>	5A gL/gG
<b>Conditional short-circuit current (1 kA)</b>	6A gG
<b>Maximum external resistance at a nominal voltage</b>	150 Ohm (S14, S24)
<b>Response time at deactivation (input - output)</b>	< 0,020 s, 0,5 s, 1 s, 1,5 s, 2 s, 3 s, ± 20%

<b>Response time at activation (input-output)</b>	<30 ms
<b>Terminals (Max. screw torque 1 Nm)</b>	Single strand: 1x4 mm <sup>2</sup> /2x1,5 mm <sup>2</sup> Conductor with socket contact: 1x2,5 mm <sup>2</sup> /2x1 mm <sup>2</sup> .
<b>Mounting</b>	35 mm DIN-rail
<b>Protection class</b>	enclosure IP 40 IEC 60529 terminals IP 20 IEC 60529
<b>Impulse Withstand Voltage</b>	2.5kV
<b>Pollution Degree</b>	2
<b>Operating temperature range</b>	-10°C – +55°C (with no icing or condensation)
<b>Operating humidity range</b>	35% to 85%
<b>LED indication</b>	Output status
<b>Weight</b>	220 g
<b>Performance (max.)</b>	Category 4/PL e Functional test: The relays must be cycled at least once a year. (EN ISO 13849-1:2008) SIL 3 (EN 62061:2005) PFH <sub>d</sub> 1.55E-08
<b>Conformity</b>	2006/42/EC, 2006/95/EC, 2004/108/EC EN 954-1:1996, EN 62061:2005 EN ISO 13849-1:2008

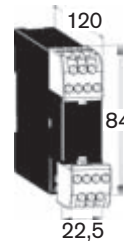

Connector blocks are detachable (without cables having to be disconnected)

## Technical description – E1T

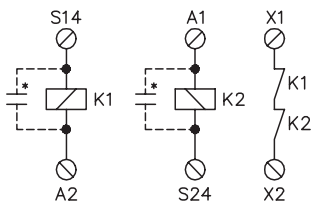

The E1T has to be connected to a safety relay in order to fulfill the necessary safety requirements (see connection examples below). The safety relay controls and monitors the E1T (The E1T can be connected for single or dual channel operation - see below). When the inputs S14 and S24

close, relays K1 and K2 are activated. A stop signal is given, K1 and K2 drop, if the inputs are opened or during power failure. K1 and K2 drop either directly or after a delay\* (if incorporated). Delay time of module is fixed and shown on front panel of device. The delay circuit is so arranged that the design time cannot be exceeded.

To check that both the relays K1 and K2

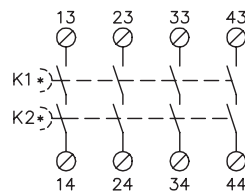

drop during a stop signal they must be monitored. This is achieved by connecting X1 and X2 to the test or reset input on the safety relay which is expanded (see below). K1 and K2 are mechanically operated relays, therefore, if one of the output contacts in X1-X2 cannot be closed thus preventing a new ready signal being given to the safety relay.

Inductive loads should be equipped with an arc suppressor to protect the output contacts.

Diodes are the best arc suppressors but will increase the switch off time of the load.

## Electrical connection – E1T

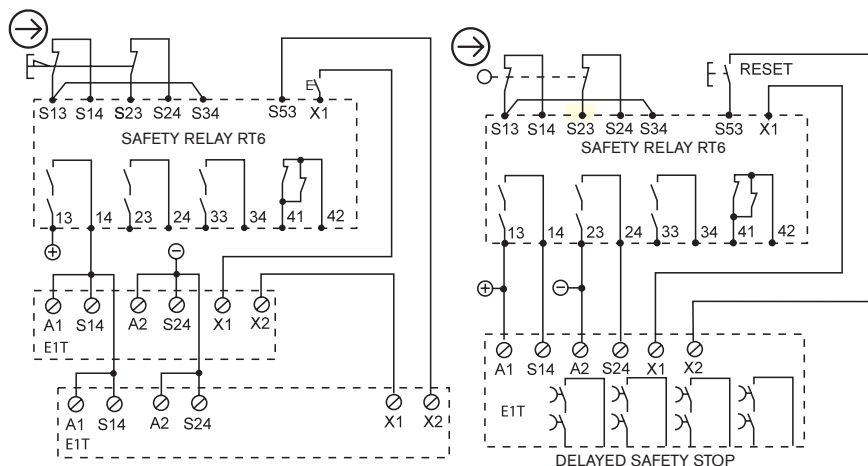

Single channel expansion of outputs for a safety relay connected to an emergency stop. Dual channel expansion with delayed safety outputs for a safety relay monitoring a gate.



# Expansion relay

# JSR1T

## Approvals:



## Expansion relay with:

- More safe outputs
- Delayed safe outputs
- Information output

## Features:

- Width 45 mm
- Supply 24 VDC
- LED function indication
- 4 NO/1 NC relay outputs
- Single and dual channel
- Quick release connector blocks

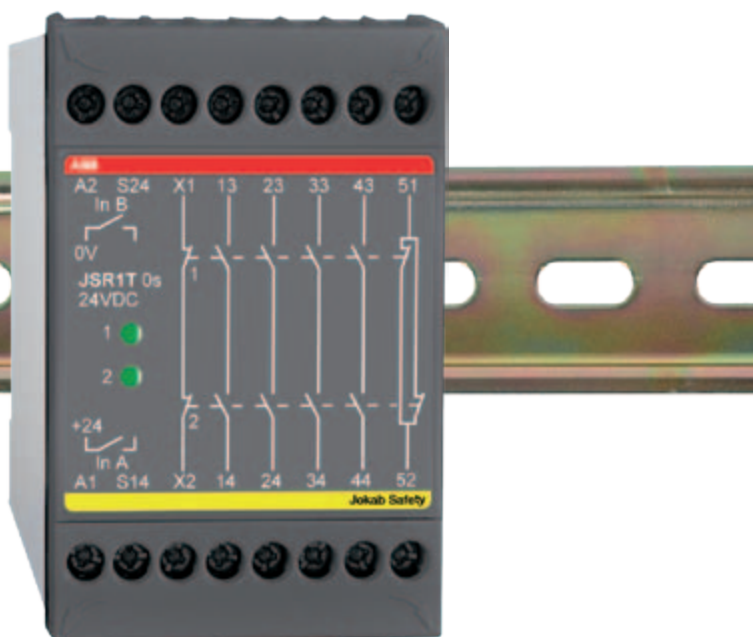

### More outputs

By connecting expansion relays to a safety relay it is easy to increase the number of safe outputs. This means that an unlimited number of dangerous machine operations and functions can be stopped from one safety relay.

### Safe soft stop

When a gate is opened a program stop is first given to the machine's PLC/servo which brakes the dangerous operations in a soft and controlled way. The safety outputs then break the power to the motors, that is, when the machine has already stopped. Normally between 0.5 and 1 second is needed to brake a dangerous machine operation softly.

Soft stop ensures many advantages:

- The machine lasts longer.
- Parts being processed are not damaged.
- Restart from stopped position is enabled and simplified.

A safe soft stop is achieved by means of a safety relay which gives the program stop, and an expansion relay, JSR1T, which gives safe delayed stop signals. See section "Connection examples". The drop time delay on a JSR1T can as standard be selected from 0 to 10 seconds. By connecting several JSR1T's in series even longer times can be achieved.

### When are delayed safe stops used?

Delayed safety stop signals can be used for emergency stops according to EN418 § 4.1.4 Stop category 1, i.e. a controlled stop with power to the actuator(s) available to achieve the stop and then removal of power when stop is achieved.

Stop category 1 may also be permitted when it is not possible to gain physical access to the machine before the safe stop is affected e.g:

- Gates, access time is normally over 1 sec.
- Covers and gates which are locked until dangerous operations and functions have been stopped.
- Long distances between a safety device and a dangerous machine function.

### Safety level

The JSR1T has twin stop functions, that is, two relays with mechanically operated contacts. A monitored stop function is achieved by connecting the test output (terminals X1 and X2) to the test or reset input on the safety relay which is being expanded.

One condition for a safe delayed stop is that the delay time cannot increase in the event of a fault. The JSR1T complies with this requirement.

### Regulations and standards

The JSR1T is designed and approved in accordance with appropriate directives and standards. See technical data.

### Connection examples

For examples of how our safety relays can solve various safety problems, please see the section "Connection examples".



## Technical data – JSR1T

<b>Manufacturer</b>	ABB AB/Jokab Safety, Sweden
<b>Article number/Ordering data</b>	
JSR1T 0	6 A 24 DC 2TLA010015R0000
JSR1T 1,5	6 A 24 DC 2TLA010015R0500
JSR1T 8	6 A 24 DC 2TLA010015R0600
JSR1T 0,5	6 A 24 D 2TLA010015R1000
JSR1T 10s	6 A 24 DC 2TLA010015R2000
JSR1T 1	6 A 24 DC 2TLA010015R3000
JSR1T 2	6 A 24 DC 2TLA010015R4000
JSR1T 3	6 A 24 DC 2TLA010015R5000
JSR1T 5	6 A 24 DC 2TLA010015R6000
<b>Colour</b>	Grey
<b>Power supply</b>	24 VDC ±15%
<b>Power consumption</b>	1.2 W
<b>Relay Outputs</b>	4 NO + 1 NC
<b>Max. switching capacity</b>	
Resistive load AC	6A/250 VAC/1500 VA
Inductive load AC	AC15 240VAC 2A
Resistive load DC	6A/24 VDC/150 W
Inductive load DC	DC13 24VDC 1A
<b>Max. total switching capacity:</b>	16A distributed on all contacts
<b>Min. load</b>	10mA/10 V (if load on contact has not exceeded 100 mA)
<b>Contact material</b>	Ag + Au flash
<b>Fuses Output (External)</b>	5A gL/gG
<b>Conditional short-circuit current (1 kA)</b>	6A gG
<b>Max. Input wire res. at nom. voltage</b>	150 Ohm (S14, S24)
<b>Response time at deactivation (input-output)</b>	< 0,020 s, 0,5 s, 1 s, 1,5 s, 2 s, 3 s, 5 s, 8 s, 10 s ± 20 %

<b>Terminals (Max. screw torque 1 Nm)</b>	
Single strand:	1 x 2,5 mm <sup>2</sup> /2 x 1mm <sup>2</sup>
Conductor with socket contact:	1 x 4 mm <sup>2</sup> /2 x 1,5 mm <sup>2</sup>
<b>Mounting</b>	35 mm DIN-rail
<b>Protection class enclosure/terminals</b>	IP 40/20 IEC 60529
<b>Impulse Withstand Voltage</b>	2.5kV
<b>Pollution Degree</b>	2
<b>Operating temperature range</b>	-10°C to +55°C (with no icing or condensation)
<b>Operating humidity range</b>	35% to 85%
<b>LED indication</b>	Output Relay Supplies
<b>Weight</b>	280 g
<b>Performance (max.)</b>	Category 4/PL e (EN ISO 13849-1:2008) SIL 3 (EN 62061:2005) PFH <sub>d</sub> 1.55E-08 Functional test: The relays must be cycled at least once a year
<b>Conformity</b>	2006/42/EC, 2006/95/EC, 2004/108/EC EN 954-1:1996, EN 62061:2005 EN ISO 13849-1:2008

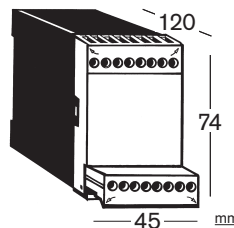

Connector blocks are detachable (without cables having to be disconnected)

## Technical description – JSR1T

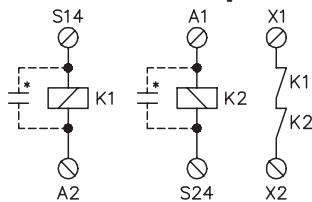

The JSR1T has to be connected to a safety relay in order to fulfill the necessary safety requirements (see connection examples below). The safety relay controls and monitors the JSR1T. (The JSR1T can be connected for single or dual channel operation - see below). When the inputs S14 and S24 close, relays K1 and K2 are activated. A stop

signal is given, K1 and K2 drop, if the inputs are opened or during power failure. K1 and K2 drop either directly or after a delay\* (If incorporated). Delay time of module is fixed and shown on front panel of device. The delay circuit is so arranged that the design time cannot be exceeded.

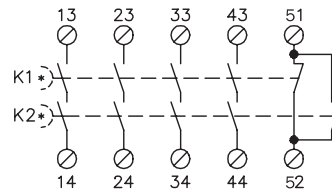

To check that both the relays K1 and K2 drop during a stop signal they must be monitored. This is achieved by connecting X1 and X2 to the test or reset input on the safety relay which is expanded (see below). K1 and K2 are mechanically operated relays, therefore, if one of the output contacts should stick closed then the relay's contact in X1-X2 cannot be closed thus preventing a new ready signal being given to the safety relay.

Inductive loads should be equipped with an arc suppressor to protect the output contacts.

Diodes are the best arc suppressors but will increase the switch off time of the load.

## Electrical connection – JSR1T

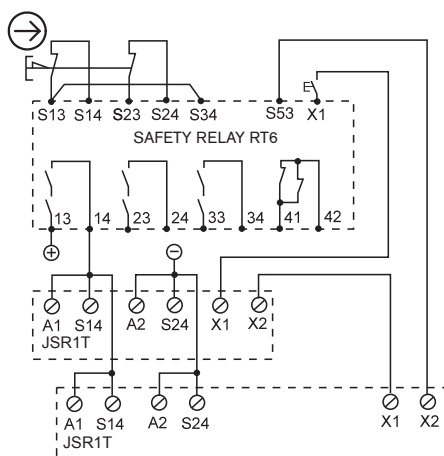

Expansion of outputs for safety relay connected to emergency stop with automatic reset.

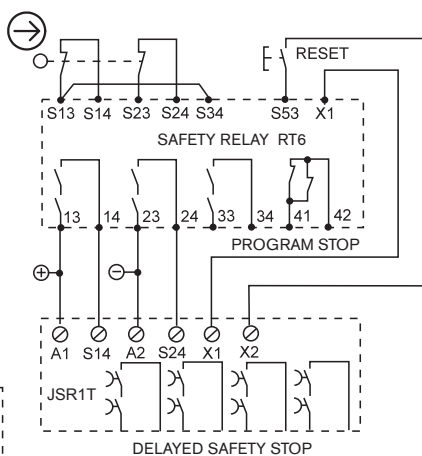

Dual-channel expansion with delayed safety outputs for safety relay monitoring a gate.

# Expansion relay

# JSR2A



## Approvals:



## Expansion relay with:

- More safe outputs
- Greater current switching capacity
- Information output

## Features:

- Switching capacity of up to 10 A/250V per output
- Width 45 mm
- LED function indication
- 4 NO/1 NC relay outputs
- 5 supply versions
- Supply 24 VDC/VAC, 48 VAC, 115 and 230 VAC
- Quick release connector blocks

### More outputs

The JSR2A expansion relay is used to provide increased switching capacity and number of safety outputs to a safety relay. This means that an unlimited number of dangerous machine operations and functions can be stopped from one safety relay.

### Greater current switching capacity

The JSR2A Expansion relay enables switching of up to 10 amps (AC/DC) per output contact.

### Safety level

The JSR2A has twin stop functions, that is, two relays with mechanically positively guided contacts. A monitored stop function is achieved by connecting the test output (terminals X1 and X2) to the test or reset input on the safety relay which is to be expanded.

### Regulations and standards



The JSR2A is designed and approved in accordance with appropriate directives and standards. See technical data.

### Connection examples

For examples of how our safety relays can solve various safety problems, please see the section "Connection examples".

## Technical data – JSR2A

<b>Manufacturer</b>	ABB AB/Jokab Safety, Sweden
<b>Article number/Ordering data</b>	JSR2A 10 A 24 AC/DC JSR2A 10 A 115 AC JSR2A 10 A 230 AC
	2TLA010027R0100 2TLA010027R0400 2TLA010027R0500
<b>Colour</b>	Grey
<b>Supply A1 - A2</b>	24 VDC/AC, 48, 115, 230 VAC + 15%, 50-60 Hz
<b>Power consumption</b>	2.7W/2.4-4 VA
<b>Relay Outputs</b>	4 NO + 1 NC
<b>Max. switching capacity</b>	
<b>Resistive load AC</b>	8A/230 VAC/1840 VA 10A/115VAC/48VAC/24VAC/ 1840 VA
<b>Inductive load AC</b>	AC15 230VAC 4A (NO-contact) 1.5A (NC-contact)
<b>Resistive load DC</b>	8A/24 VDC/192 W
<b>Inductive load DC</b>	DC13 24VDC 1.2A (NO/NC-contact)
<b>Max. total switching capacity:</b>	16A distributed on all contacts
<b>Min. load</b>	10mA/10V/100mW (if load on contact has not exceeded 100 mA)
<b>Contact material</b>	AgSnO <sub>2</sub> + Au flash
<b>Fuses Output (External)</b>	6A gL ( 8A fast if short-circuit current >500A )
<b>Conditional short-circuit current (1 kA)</b>	10A gG
<b>Max. Input wire res. at nom. voltage</b>	24 VDC/VAC: 100 Ohm 48/115/230 VAC: 200 Ohm
<b>Mechanical operational Life</b>	>10 <sup>7</sup> operations
<b>Response time at</b>	
deactivation (input- output)	<25 ms
activation (input - output):	<15 ms
<b>Terminals (removable)</b>	
Max. screw torque	1 Nm

<b>Connection Area (max.)</b>	
Single strand	1 x 4 mm <sup>2</sup> or 2 x 1.5 mm <sup>2</sup> /12AWG
Conductor with socket contact	1 x 2.5 mm <sup>2</sup> or 2 x 1 mm <sup>2</sup>
<b>Mounting</b>	35 mm DIN-rail
<b>Protection class terminals</b>	
Enclosure	IP 40 IEC 60529
Terminals	IP 20 IEC 60529
<b>LED indication</b>	
On 	Supply voltage
 1  2	Output relays 1 and 2
<b>Impulse Withstand Voltage</b>	2.5kV
<b>Pollution Degree</b>	2
<b>Operating temperature range</b>	-10°C to +55°C (with no icing or condensation)
<b>Operating humidity range</b>	35% to 85%
<b>Weight</b>	313 g
<b>Performance (max.)</b>	
Functional test: The relays must be cycled at least once a year	Category 4/PL e (EN ISO 13849-1:2008) SIL 3 (EN 62061:2005) PFH <sub>d</sub> 1.55E-08
<b>Conformity</b>	2006/42/EC, 2006/95/EC, 2004/108/EC EN 954-1:1996, EN 62061:2005 EN ISO 13849-1:2008

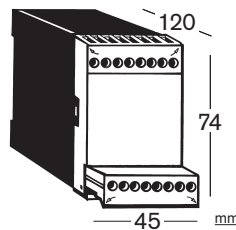

Connector blocks are detachable (without cables having to be disconnected)

## Technical description – JSR2A

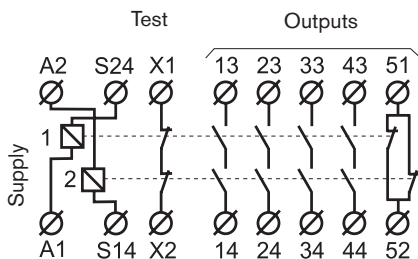

The JSR2A has to be connected to a suitable safety relay in order to fulfill the necessary safety requirements (see chapter "Connection examples"). The Safety Relay controls and monitors the JSR2A unit. (The JSR2A can be connected for single or dual channel operation - see Electrical connection diagrams below). When the inputs to S14 and S24 close, internal relays K1 and K2 are activated. A stop signal is given, K1 and K2 drop, if the inputs are opened or during power failure.

To check that both the K1 and K2 relays drop during a stop signal they must be monitored. This is achieved by connecting X1 and X2 to the test or reset input on the safety relay which is expanded. K1 and K2 have mechanically positively guided contacts, therefore, if one of the output contacts should stick closed then the relay's contact in X1-X2 cannot be closed thus preventing a new ready signal being given to the safety relay.

## Electrical connection – JSR2A

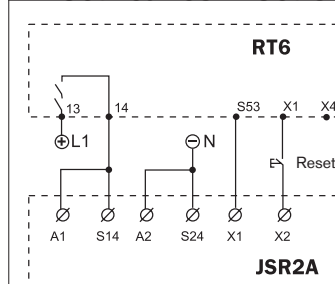

One channel expansion of RT6 with JSR2A connected for manual reset.

Dual channel expansion of RT6 with JSR2A connected for automatic reset.

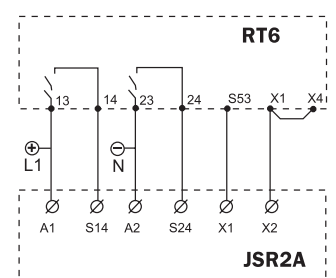

# Expansion relay

# JSR3T



## Approvals:



## Expansion relay with delay with:

- Safe delay of stop signals with selectable value
- Delayed safe outputs

## Features:

- Width 22.5 mm
- Supply 24V AC/DC
- Output indication
- 2 x 1 NO relay outputs
- Hardwire Selectable Delay 0.5 - 10.0 sec by hardwire links and Time trim potentiometer

### Delayed outputs

By connecting the JSR3T expansion relay to a compatible Safety relay it is easy to obtain safe "delayed" outputs.

The JSR3T provides the system designer with the facility to hardwire selected time delays in steps between 0.5 and 10 seconds.

### Use of delayed outputs

There are many applications where delayed outputs are necessary and permissible. For example delayed stop signals can be used for emergency stops according to EN ISO 13850:2008 § 4.1.4 Stop Category 1 (a controlled stop with power to the machine actuator(s) available to achieve the stop and then removal of power when stop is achieved). Stop Category 1 may also be permitted when it is not possible to gain physical access to the machine before the safe stop is effected e.g. by:

- Covers and Gates which are locked until dangerous operations and functions have been stopped.
- Long distances between a safety device and dangerous machine functions.

Using this technique of stopping a machine provides many advantages i.e.:

- Machines last longer as they are not subjected to excessive loading etc when requested to stop.
- Parts being processed are not damaged.
- Restarting machines from stopped position is simplified.

A safe "Soft" stop is achieved by means of a safety relay giving a programme stop to the machine control system. e.g. when a gate is opened or emergency stop is activated. The output of the Safety relay is used to provide both a stop signal to the machine control system i.e. via a PLC which applies the necessary braking/stopping of the machine in a

controlled way, and to switch a delayed expansion relay e.g. JSR3T. The delayed safety outputs of the JSR3T expansion relay are then used to control the safe disconnection of the power to the actuators/motors etc. of the machine.

### Safety level

The JSR3T has twin stop functions, using two positively guided contact relays.

In order to achieve the level of monitoring required the JSR3T must be used with a suitable Safety Relay e.g. JSBR4, or RT6. The JSR3T test output (terminals X1 and X2) must be connected to the test input of the Safety relay being expanded (see connection examples).

The JSR3T provides delay times that even in the event of an internal fault condition complies with the requirement that the set delay cannot increase in time.

### Regulations and standards

The JSR3T is designed and approved in accordance with appropriate directives and standards. Examples of such are 98/37/EC, EN ISO 12100-1/-2, EN 60204-1, EN 954-1/ EN ISO 13849-1.

### Connection examples

For examples of how our safety relays can solve various safety problems, please see the section "Connection examples".

## Technical data – JSR3T

<b>Manufacturer</b>	ABB AB/Jokab Safety, Sweden
<b>Article number/Ordering data</b> JSR3T 24 AC/DC	2TLA010017R0100
<b>Colour</b>	Grey
<b>Power supply</b>	24 VAC/DC, 50 - 60 Hz
<b>Power consumption</b>	1.3 VA/W
<b>Relay Outputs</b>	2 x 1 NO (See Connection examples)
<b>Max. switching capacity</b> Resistive load AC Inductive load AC Resistive load DC Inductive load DC	4A/250VAC/1000 VA AC15 240VAC 3A 4A/24 VDC/100 W DC13 24VDC 2A
<b>Max. res. load total switching capacity:</b>	6A distributed on all contacts
<b>Min. load</b>	10mA/10V (if load on contact has not exceeded 100 mA)
<b>Contact material</b>	AgNi
<b>Fuses Output (External)</b>	3A gL/gG or 4A fast
<b>Conditional short-circuit current (1 kA)</b>	6A gG
<b>Max Input Wire res. at nom. voltage</b>	100 Ohm
<b>Response time at activation</b>	<20ms
<b>Response time at deactivation</b>	<0.5 - 10.0 sec. at nom. voltage. Selected delay can be lowered by up to approx. 30% by means of preset potentiometer on front panel.

<b>Terminals (Max. screw torque 1 Nm)</b>	Single strand: 2x1.5 mm <sup>2</sup> Conductor with socket contact: 2x1mm <sup>2</sup> .
<b>Mounting</b>	35 mm DIN-rail
<b>Protection class enclosure/ terminals</b>	IP 40/20 IEC 60529
<b>Impulse Withstand Voltage</b>	2.5kV
<b>Pollution Degree</b>	2
<b>Operating temperature range</b>	-10°C to +55°C (with no icing or condensation)
<b>Operating humidity range</b>	35% to 85%
<b>LED indication</b>	Outputs
<b>Weight</b>	158 g
<b>Performance (max.)</b> Functional test: The relays must be cycled at least once a year.	Category 4/PL e (EN ISO 13849-1:2008) SIL 3 (EN 62061:2005) PFH <sub>d</sub> 3.67E-09
<b>Conformity</b>	2006/42/EC, 2006/95/EC, 2004/108/EC EN 954-1:1996, EN 62061:2005 EN ISO 13849-1:2008

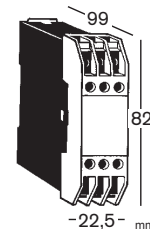

## Technical description – JSR3T

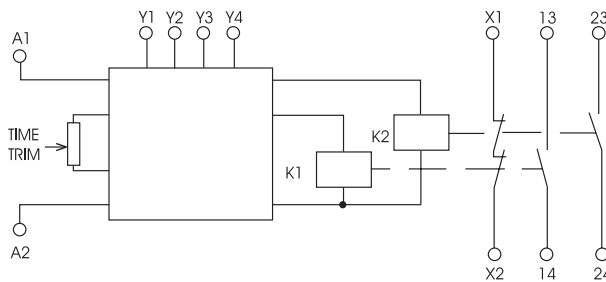

When supply voltage is connected to A1 and A2, relays K1 and K2 are activated. When the supply voltage is removed relays K1 and K2 remain energized for a time period

determined by the hardwire link configuration chosen (set by connecting links on the terminals Y1, Y2, Y3 and Y4.) and the setting of the Time Trim potentiometer.

### NOTE 1

Max. time set by hardwire links can only be reduced (up to approx. 30% reduction) by Time Trim potentiometer.

### NOTE 2

Both the output contacts of K1 and K2 (13 - 14 and 23 - 24) must be used. Output contacts must be either connected in series (forming one safety output) or used in parallel circuits in order to obtain necessary redundancy.

## Electrical connection – JSR3T

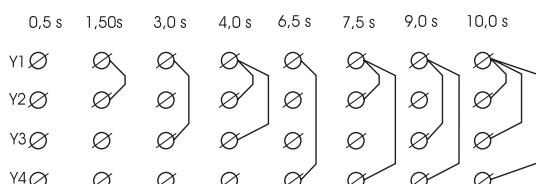
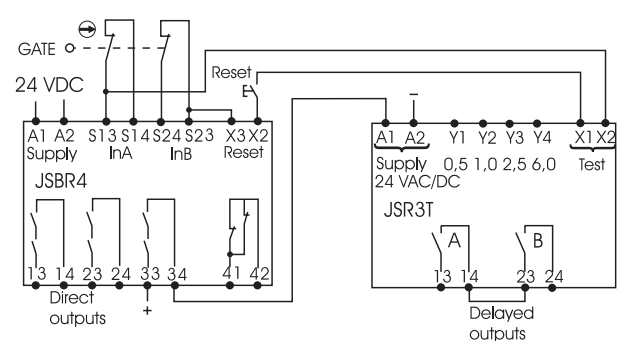
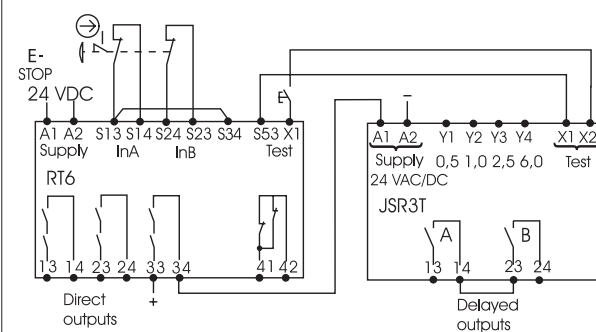

It is recommended that all switched loads are adequately suppressed and/or fused in order to provide additional protection for the safety contacts.

Selection of time delay by hardwire links (Y1, Y2, Y3, Y4).

Selected delay can be lowered by up to approx. 30% by means of preset potentiometer on front panel.



## Contents - Connection examples

Page

HA5400A Connection examples JSBR4	6:43
HA6400A Connection examples JSBT4	6:43
HA6500A Connection examples JSBT5	6:44
HA6500B Connection examples BT50	6:44
HA6501B Connection examples BT50T	6:45
HA6500C Connection examples BT51	6:45
HA6501C Connection examples BT51T	6:46
HA7100A Connection examples JSBRT11	6:46
HA7600A Connection examples RT6	6:47
HA7600B Principle drawing RT6	6:47
HA7672A Enabling device JSHD4 - EX with RT6	6:48
HA7700A Connection examples RT7	6:48
HA7900A Connection examples RT9	6:49
HE3811B Safety Light Beam Spot with time-limited reset	6:49
HE3824C Lightbeam with time-limited bypass 0.2–40 s	6:50
HE3824E Lightbeams with time-limited bypass 0.2–40 s	6:50
HG7636B Focus light grid/curtain with three-position device	6:51
HG7611A Interlocked door with RT6 and pre-reset	6:51
HG7636A Interlocked door with three-position device	6:52
HG7646A Interlocked door with three-position device and time-limited entrance/exit	6:52
HG7654A Interlocked door with RT6 and output expansion JSR1T	6:53
HG7658A Interlocked door with RT6 and output expansion JSR2A	6:53
HG7673A Interlock switch JSNY8 with RT6	6:54
HG7674A Safety interlock switch JSNY9M/MLA with RT6	6:54
HG7674B Safety interlock switch JSNY9S/SLA with RT6	6:55
HH0000C Three-position device JSHD4 with various safety controllers	6:55
HI8552A Connection examples JSHT2 intermittent running	6:56
HK7600A Safety mat/Contact strip with RT6	6:56
HL7600B Several JSNY7 connected to one RT6 with unique indication	6:57
HM0000A Magnetic switch JSNY7 with various safety controllers	6:57
HN7660A Delayed outputs RT6 with output expansion JSR3T and RT7	6:58
HP7600A Machine control - Isolation of PLC inputs and outputs	6:58
HP7600B Machine control-Isolation of PLC outputs	6:59
HR7200B Focus light curtain/beam	6:59
HR7800B Focus lightbeam/curtain	6:60
HT5400A Two-hand device with safety relay JSBR4	6:60
HB0008A Focus light curtain/light beam connected to an RT9 with the aid of a M12-3D	6:61



# HA5400A Connection examples JSBR4

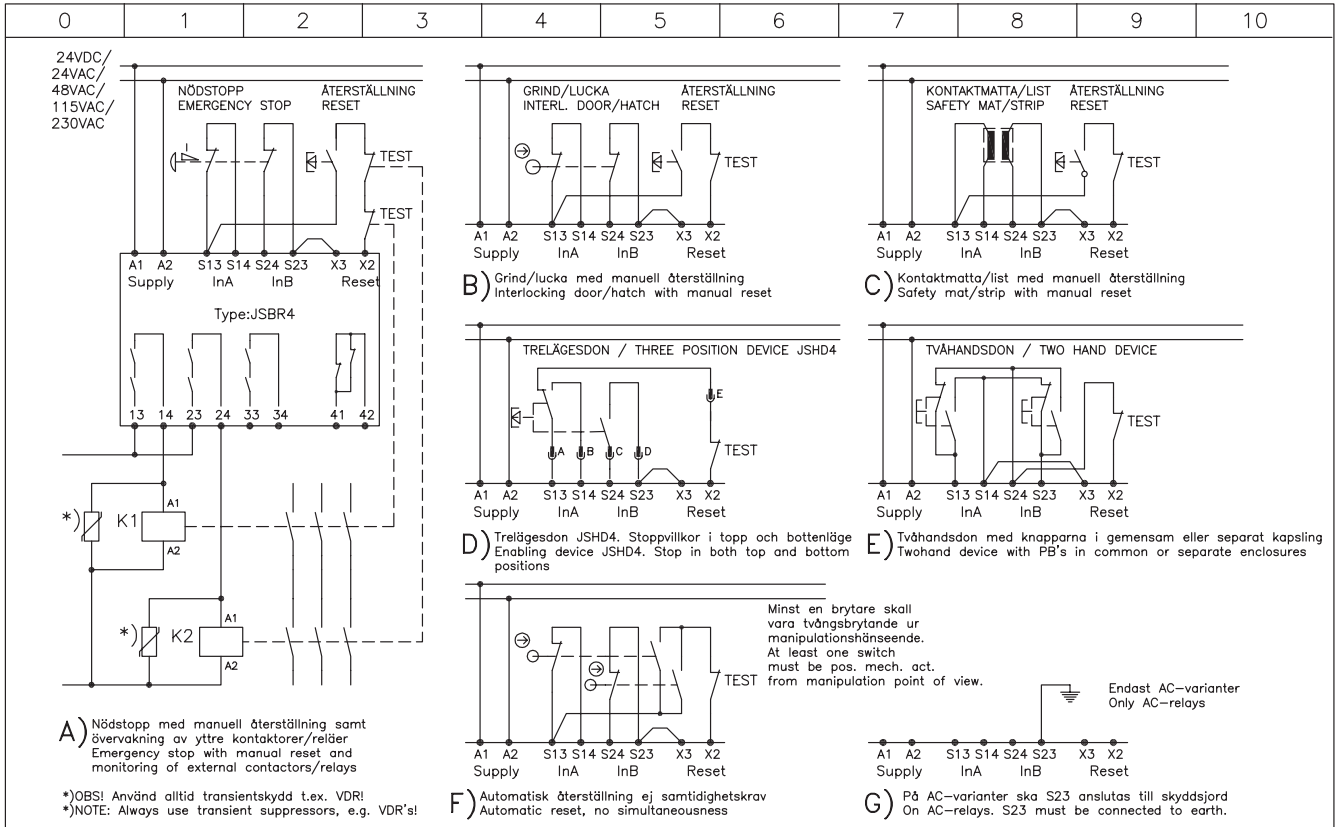

Anmärkning Remark ANSLUTNINGSEXEMPEL JSBR4 CONNECTION EXAMPLES JSBR4	Konstr Design	Godk Appr	Datum Date	Blad Sheet
	Ritad Drawn	Sidor Pages	Ritn nr Drawing no	Forts Cont
	JS	1	990120	1
	JS	1	HA5400A	-

It is the user's responsibility to ensure that all control devices are correctly installed, cared for and operated to meet all applicable European, national and local codes/regulations. Specifications subject to change without notice.

# HA6400A Connection examples JSBT4

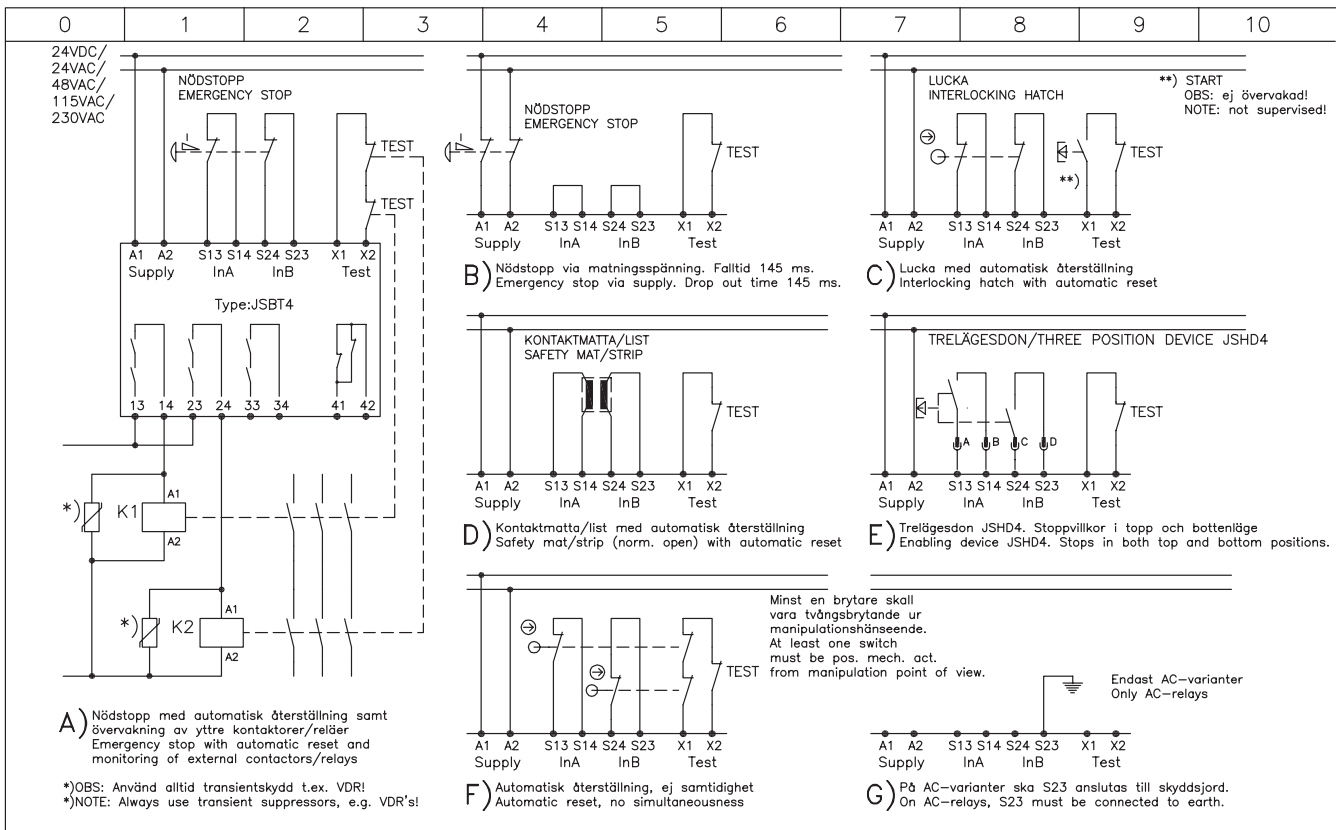

Anmärkning Remark ANSLUTNINGSEXEMPEL JSBT4 CONNECTION EXAMPLES JSBT4	Konstr Design	Godk Appr	Datum Date	Blad Sheet
	Ritad Drawn	Sidor Pages	Ritn nr Drawing no	Forts Cont
	JS	1	991206	1
	JS	1	HA6400A	-

It is the user's responsibility to ensure that all control devices are correctly installed, cared for and operated to meet all applicable European, national and local codes/regulations. Specifications subject to change without notice.

# HA6500A Connection examples JSBT5

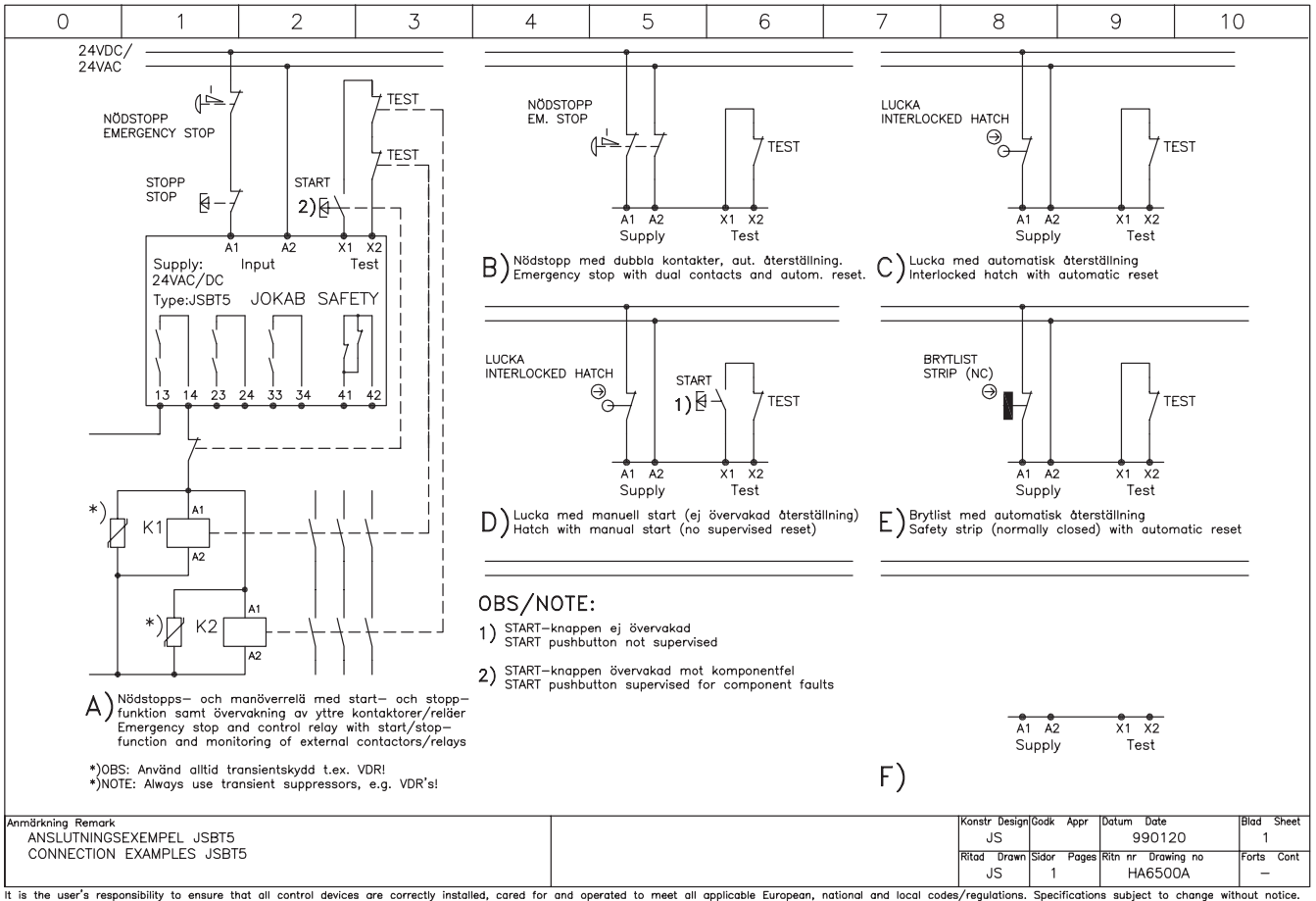

# HA6500B Connection examples BT50

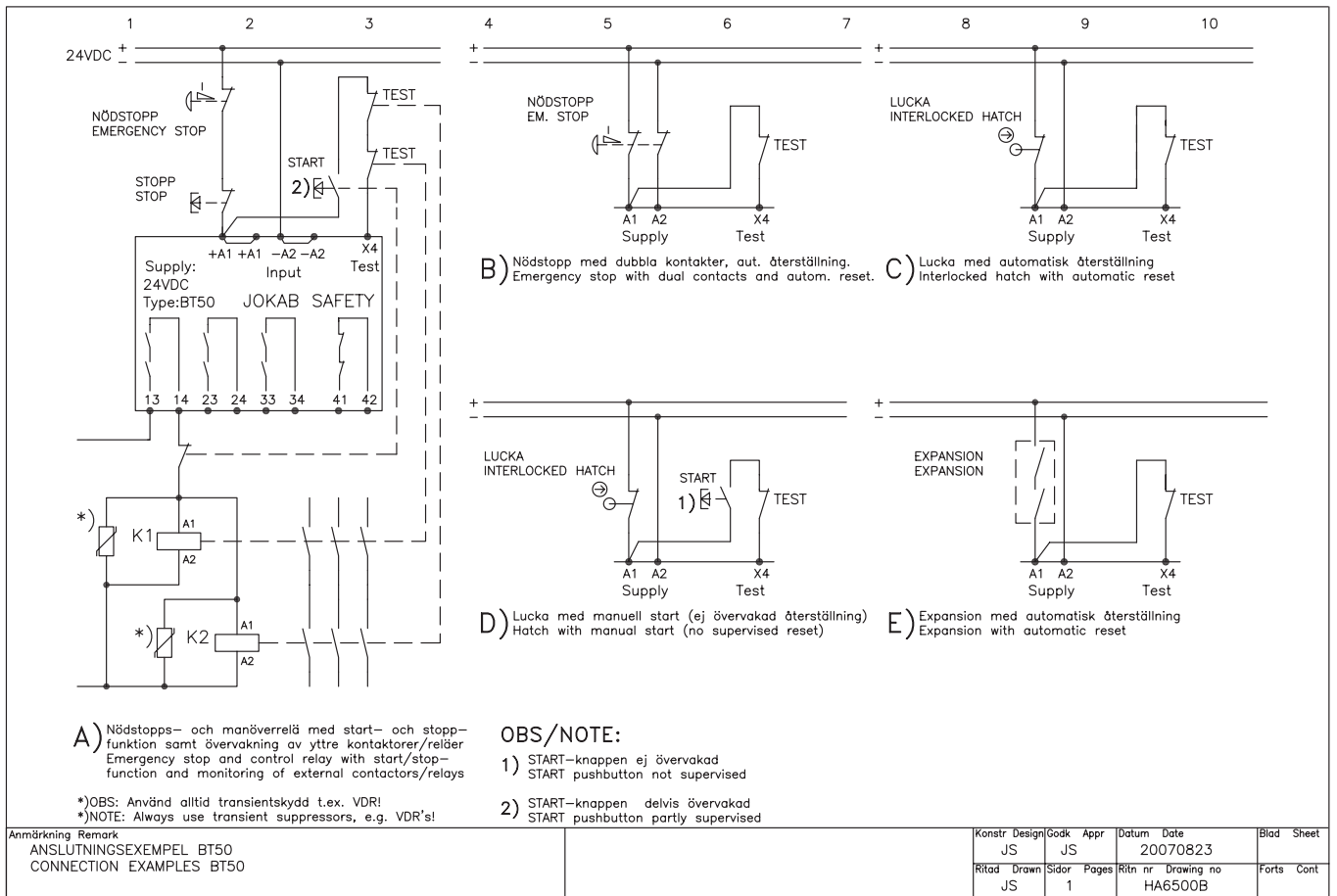

# HA6501B Connection examples BT50T

**A) Nödstopps- och manöverrelä med start- och stopp-funktion samt övervakning av yttre kontaktorer/reläer**  
Emergency stop and control relay with start/stop-function and monitoring of external contactors/relays

**B) Nödstopp med dubbla kontakter, aut. återställning.**  
Emergency stop with dual contacts and autom. reset.

**C) Lucka med automatisk återställning**  
Interlocked hatch with automatic reset

**D) Lucka med manuell start (ej övervakad återställning)**  
Hatch with manual start (no supervised reset)

**E) Expansion med automatisk återställning**  
Expansion with automatic reset

**F) BT50T Info utgång**  
BT50T Info. output

**G) BT50T Fördröjningstider**  
BT50T Delay times

**OBS/NOTE:**  
1) START-knappen ej övervakad  
START pushbutton not supervised  
2) START-knappen delvis övervakad  
START pushbutton partly supervised

**Anmärkning Remark**  
ANSLUTNINGSEXEMPEL BT50T  
CONNECTION EXAMPLES BT50T

Konstr JS	Design JS	Godk JS	Aprr JS	Datum 20070823	Blad
Ritad JS	Drawn JS	Sidor 1	Pages 1	Ritn nr HA6501B	Sheet

It is the user's responsibility to ensure that all control devices are correctly installed, cared for and operated to meet all applicable European, national and local codes/regulations. Specifications subject to change without notice.

# HA6500C Connection examples BT51

**A) Nödstopps- och manöverrelä med start- och stopp-funktion samt övervakning av yttre kontaktorer/reläer**  
Emergency stop and control relay with start/stop-function and monitoring of external contactors/relays

**B) Nödstopp med dubbla kontakter, aut. återställning.**  
Emergency stop with dual contacts and autom. reset.

**C) Lucka med automatisk återställning**  
Interlocked hatch with automatic reset

**D) Lucka med manuell start (ej övervakad återställning)**  
Hatch with manual start (no supervised reset)

**E) Expansion med automatisk återställning**  
Expansion with automatic reset

**OBS/NOTE:**  
1) START-knappen ej övervakad  
START pushbutton not supervised  
2) START-knappen delvis övervakad  
START pushbutton partly supervised

**Anmärkning Remark**  
ANSLUTNINGSEXEMPEL BT51  
CONNECTION EXAMPLES BT51

Konstr JS	Design JS	Godk JS	Aprr JS	Datum 20070828	Blad
Ritad JS	Drawn JS	Sidor 1	Pages 1	Ritn nr HA6500C	Sheet

It is the user's responsibility to ensure that all control devices are correctly installed, cared for and operated to meet all applicable European, national and local codes/regulations. Specifications subject to change without notice.

# HA6501C Connection examples BT51T

**A)** Nödstopps- och manöverrelä med start- och stopp-funktion samt övervakning av yttre kontaktorer/reläer  
Emergency stop and control relay with start/stop-function and monitoring of external contactors/relays

**B)** Nödstopp med dubbla kontakter, aut. återställning.  
Emergency stop with dual contacts and autom. reset.

**C)** Lucka med automatisk återställning  
Interlocked hatch with automatic reset

**D)** Lucka med manuell start (ej övervakad återställning)  
Hatch with manual start (no supervised reset)

**E)** Expansion med automatisk återställning  
Expansion with automatic reset

**F)** BT51T Info utgång  
BT51T Info. output

**G)** BT51T Fördröjningstider  
BT51T Delay times

**OBS/NOTE:**  
1) START-knappen ej övervakad  
START pushbutton not supervised  
2) START-knappen delvis övervakad  
START pushbutton partly supervised

**Anmärkning Remark**  
ANSLUTNINGSEXEMPEL BT51T  
CONNECTION EXAMPLES BT51T

Konstr JS	Design JS	Godk JS	Appr JS	Datum 20070910	Blad 1
Ritad JS	Drawn JS	Sidor 1	Pages 1	Ritn nr HA6501C	Forts Cont

It is the user's responsibility to ensure that all control devices are correctly installed, cared for and operated to meet all applicable European, national and local codes/regulations. Specifications subject to change without notice.

# HA7100A Connection examples JSBRT11

**A)** Nödstopp med manuell återställning samt övervakning av yttre kontaktorer/reläer  
Emergency stop with manual reset and monitoring of external contactors/relays

**B)** Grind/lucka med manuell återställning.  
Interl. door/hatch with manual reset.

**C)** Lucka med automatisk återställning.  
Interl. hatch with automatic reset.

**D)** Nödstopp med automatisk återställning.  
Emergency stop with automatic reset.

**Anmärkning Remark**  
ANSLUTNINGSEXEMPEL JSBRT11  
CONNECTION EXAMPLES JSBRT11

Konstr JS	Design JS	Godk JS	Appr JS	Datum 990120	Blad 1
Ritad JS	Drawn JS	Sidor 1	Pages 1	Ritn nr HA7100A	Forts Cont

It is the user's responsibility to ensure that all control devices are correctly installed, cared for and operated to meet all applicable European, national and local codes/regulations. Specifications subject to change without notice.

# HA7600A Connection examples RT6

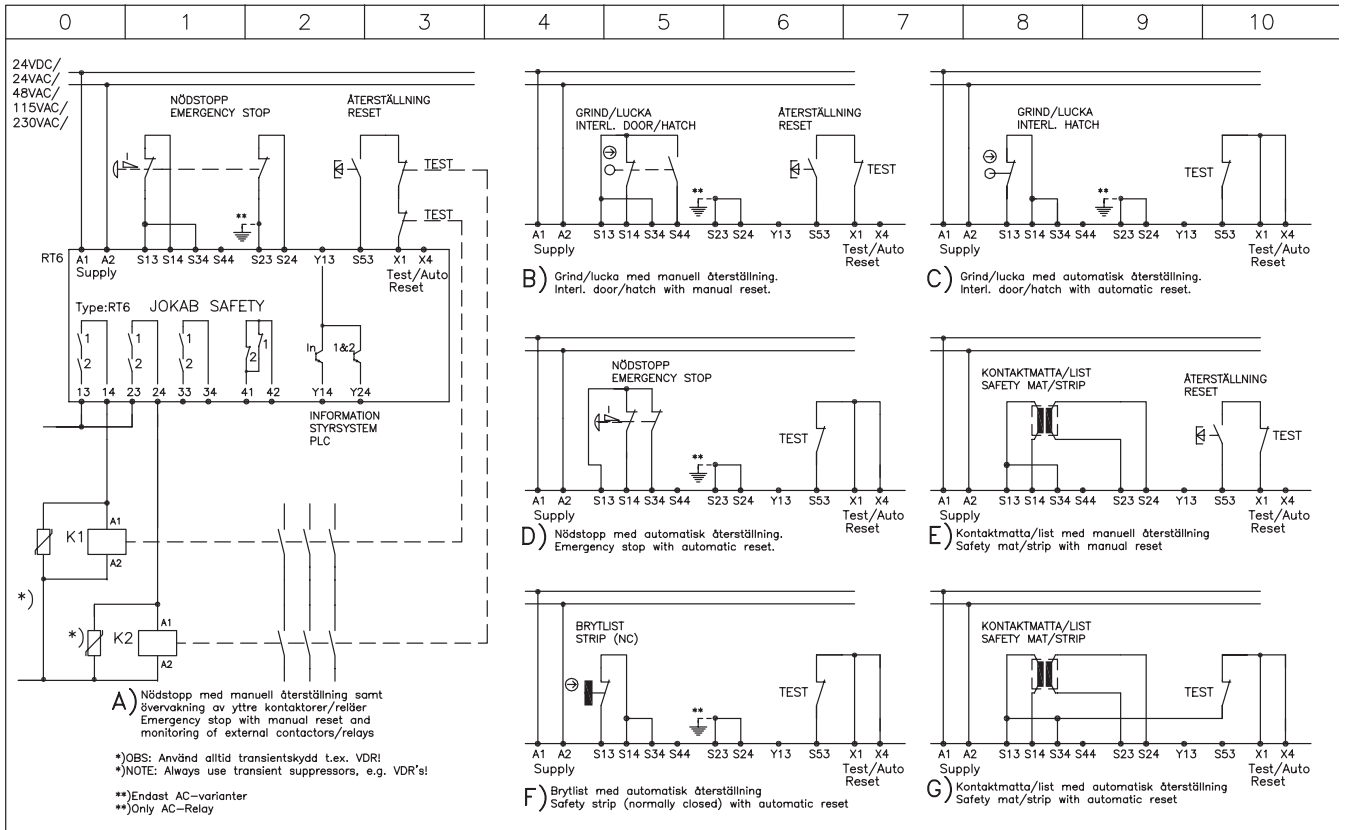

Anmärkning Remark ANSLUTNINGSEXEMPEL RT6 CONNECTION EXAMPLES RT6	Konstr Design	Godk Appr	Datum Date	Blad Sheet
	Ritad Drawn	Sidor Pages	Ritn nr Drawing no	Forts Cont
	JS		990120	1
	JS	1	HA7600A	-

It is the user's responsibility to ensure that all control devices are correctly installed, cared for and operated to meet all applicable European, national and local codes/regulations. Specifications subject to change without notice.

# HA7600B Principle drawing RT6

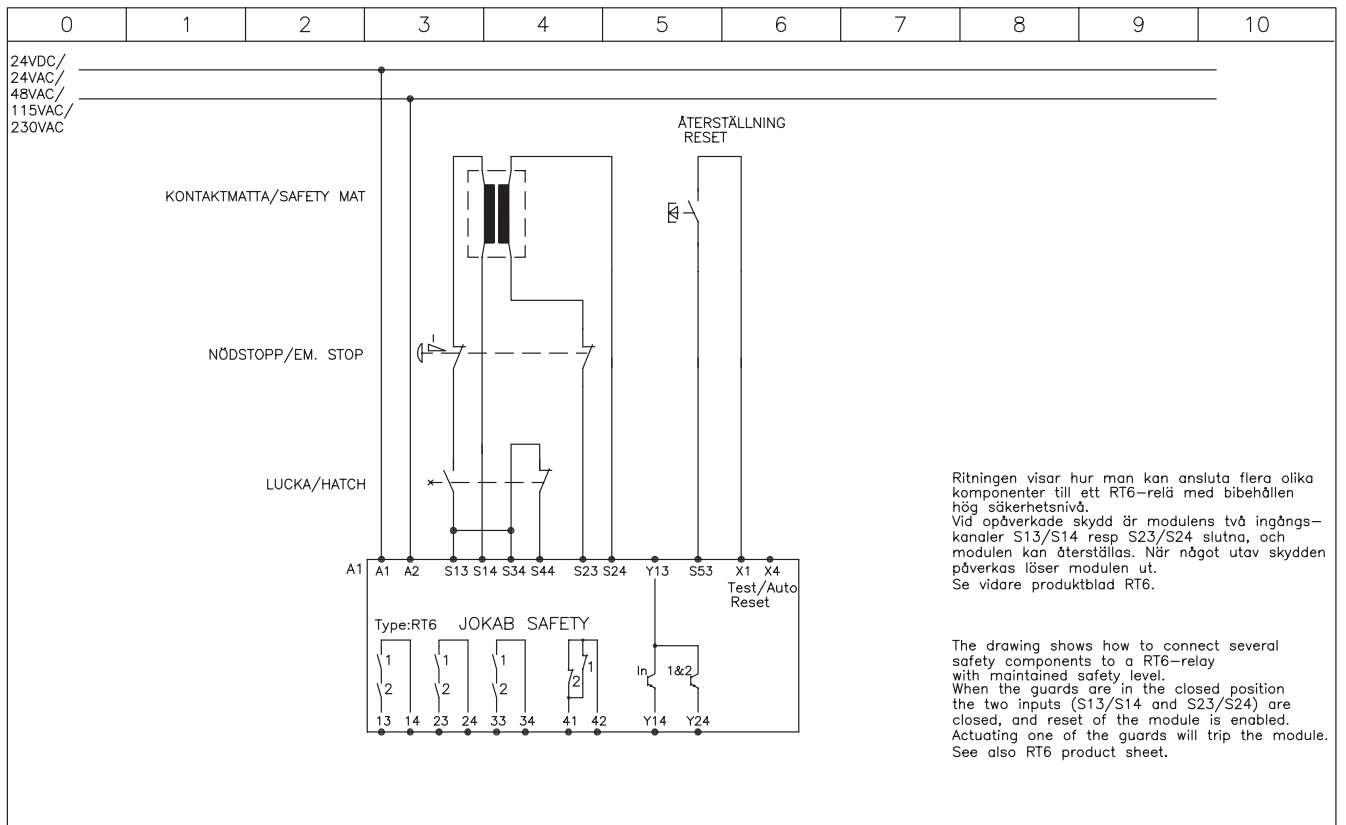

Anmärkning Remark KONTAKTMATTA, NÖDSTOPP OCH LUCKA TILL RT6 SAFETY MAT, EM. STOP AND HATCH WITH RT6 PRINCIPRITNING/PRINCIPLE DRAWING	Konstr Design	Godk Appr	Datum Date	Blad Sheet
	Ritad Drawn	Sidor Pages	Ritn nr Drawing no	Forts Cont
	JS		990409	1
	JS	1	HA7600B	-

It is the user's responsibility to ensure that all control devices are correctly installed, cared for and operated to meet all applicable European, national and local codes/regulations. Specifications subject to change without notice.

# HA7672A Enabling device JSHD4 - EX with RT6

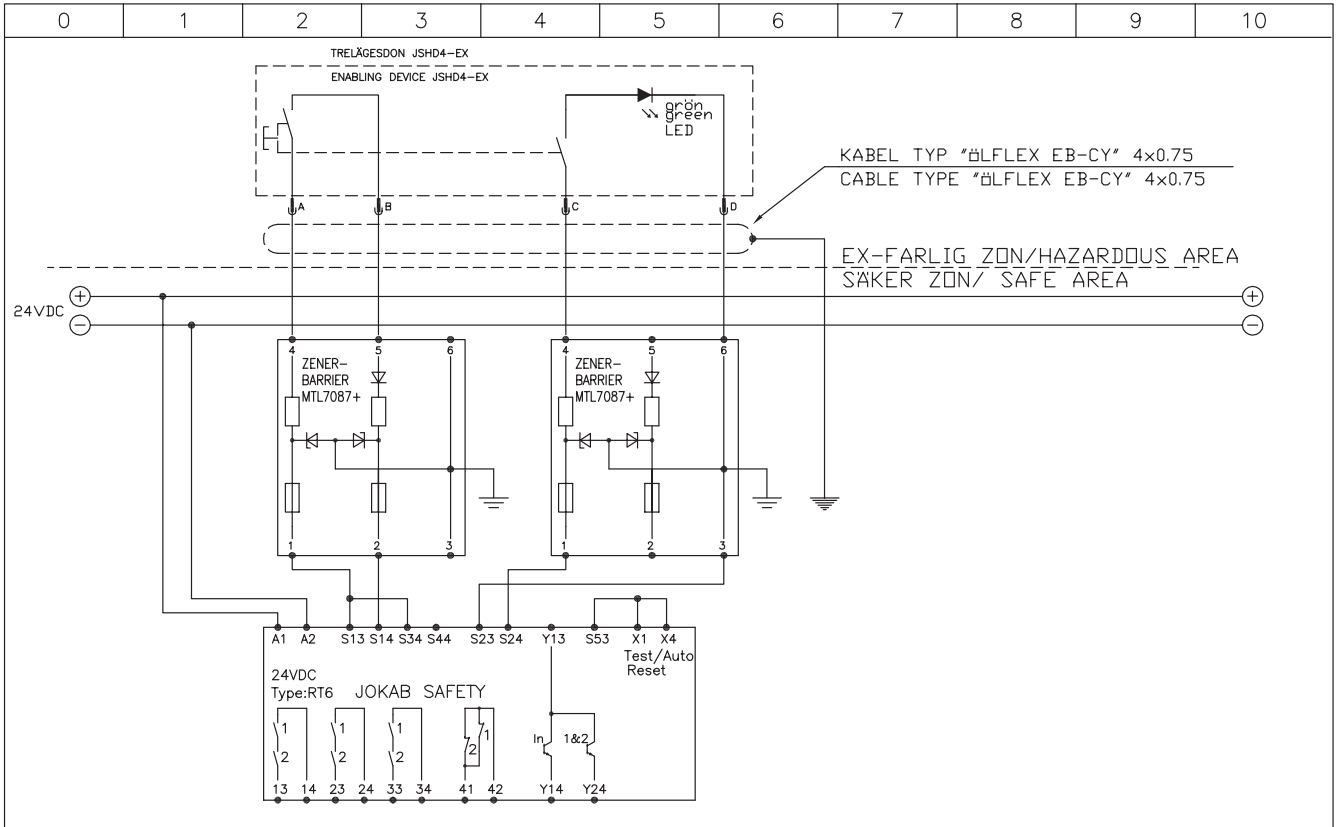

Anmärkning Remark TRELÄGESDON JSD4-EX MED RT6 ENABLING DEVICE JSHD4-EX WITH RT6	Konstr Design	Godk Appr	Datum Date	Blad Sheet
	JS		990120	1
	Ritad Drawn	Sidor Pages	Ritn nr Drawing no	Forts Cont
	JS	1	HA7672A	-

It is the user's responsibility to ensure that all control devices are correctly installed, cared for and operated to meet all applicable European, national and local codes/regulations. Specifications subject to change without notice.

# HA7700A Connection examples RT7

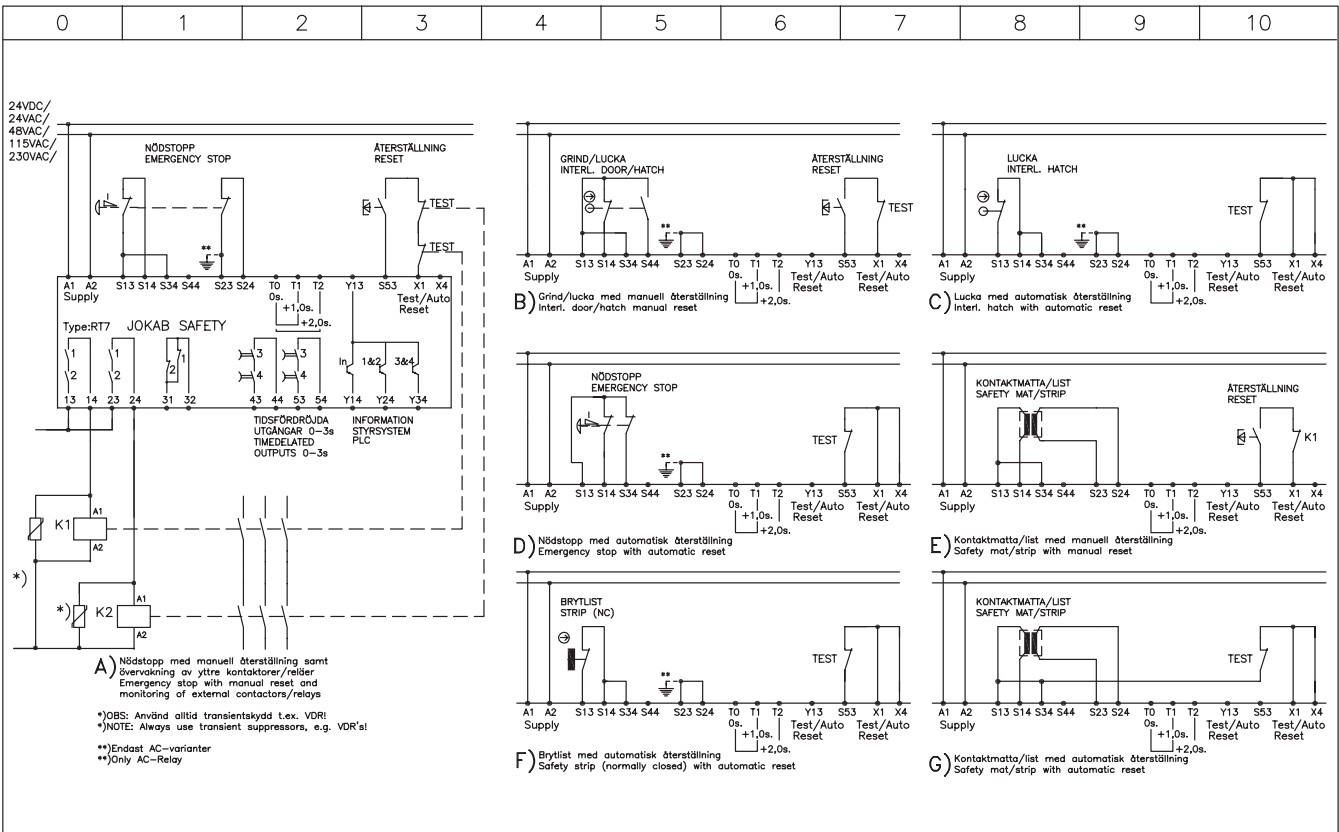

Anmärkning Remark ANSLUTNINGSEXEMPEL RT7 CONNECTION EXAMPLES RT7	Konstr Design	Godk Appr	Datum Date	Blad Sheet
	JS		990120	1
	Ritad Drawn	Sidor Pages	Ritn nr Drawing no	Forts Cont
	JS	1	HA7700A	-

It is the user's responsibility to ensure that all control devices are correctly installed, cared for and operated to meet all applicable European, national and local codes/regulations. Specifications subject to change without notice.



# HA7900A Connection examples RT9

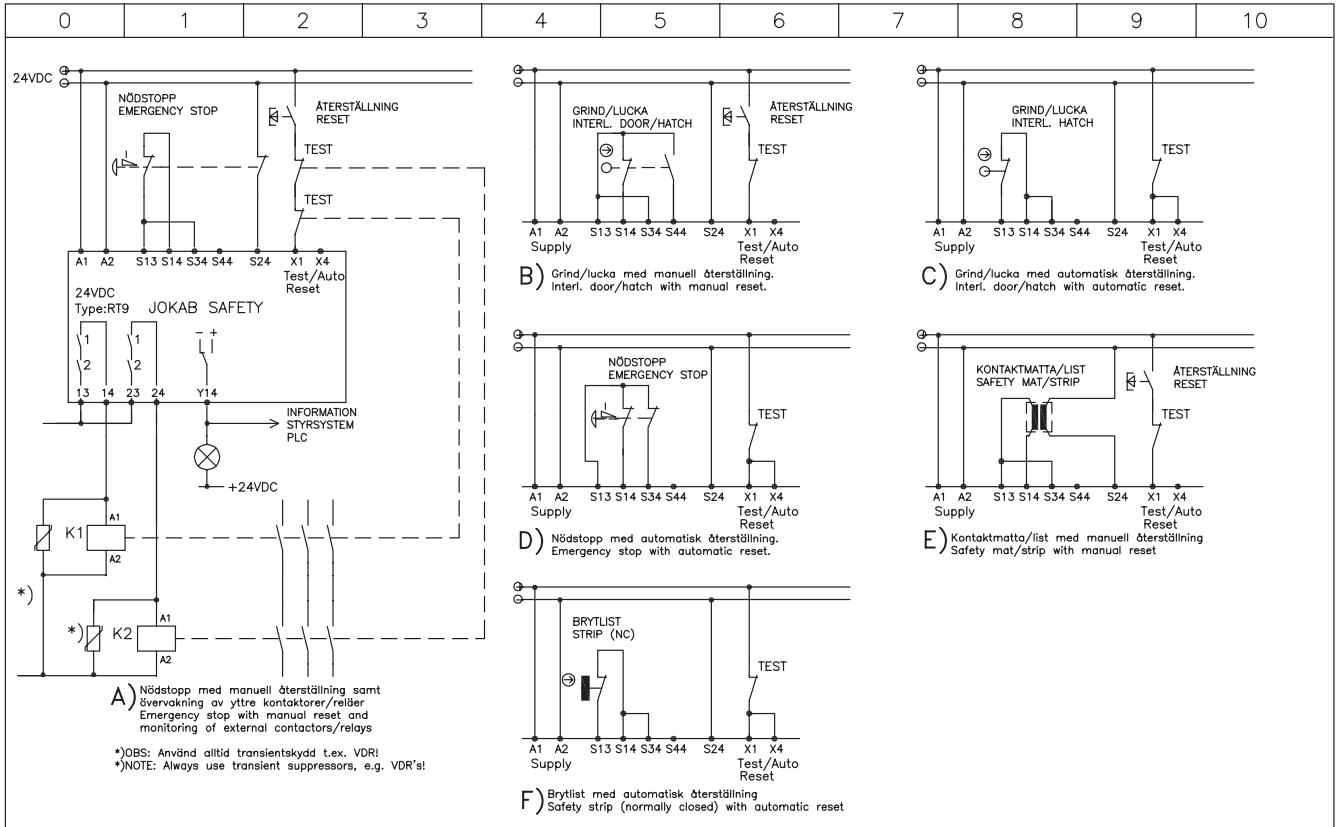

Anmärkning Remark ANSLUTNINGSEXEMPEL RT9 CONNECTION EXAMPLES RT9	Konstr Design	Godk Appr	Datum Date	Blad Sheet
	JS	JS	990120	1
	Ritad Drawn	Sidor Pages	Ritn nr Drawing no	Forts Cont
	JS	1	HA7900A	-

It is the user's responsibility to ensure that all control devices are correctly installed, cared for and operated to meet all applicable European, national and local codes/regulations. Specifications subject to change without notice.

# HE3811B Safety Light Beam Spot with time-limited reset

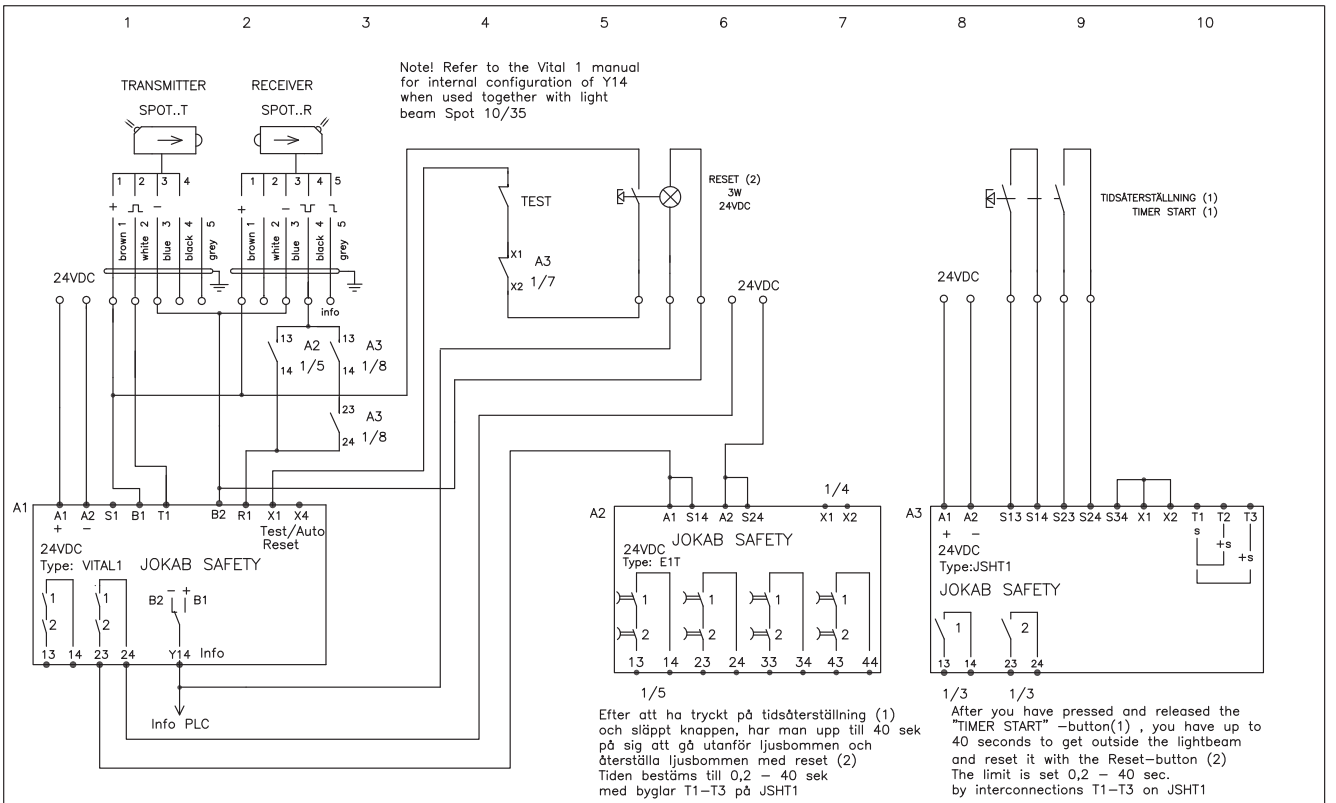

Anmärkning Remark LJUSBOM SPOT MED TIDSÅTERSTÄLLNING SAFETY LIGHT BEAM SPOT WITH TIME-LIMITED RESET	Konstr Design	Godk Appr	Datum Date	Blad Sheet
	JS	JS	20110318	1
	Ritad Drawn	Sidor Pages	Ritn nr Drawing no	Forts Cont
	JS	1	HE3811B-01	-

# HE3824C Lightbeam with time-limited bypass 0.2-40 s

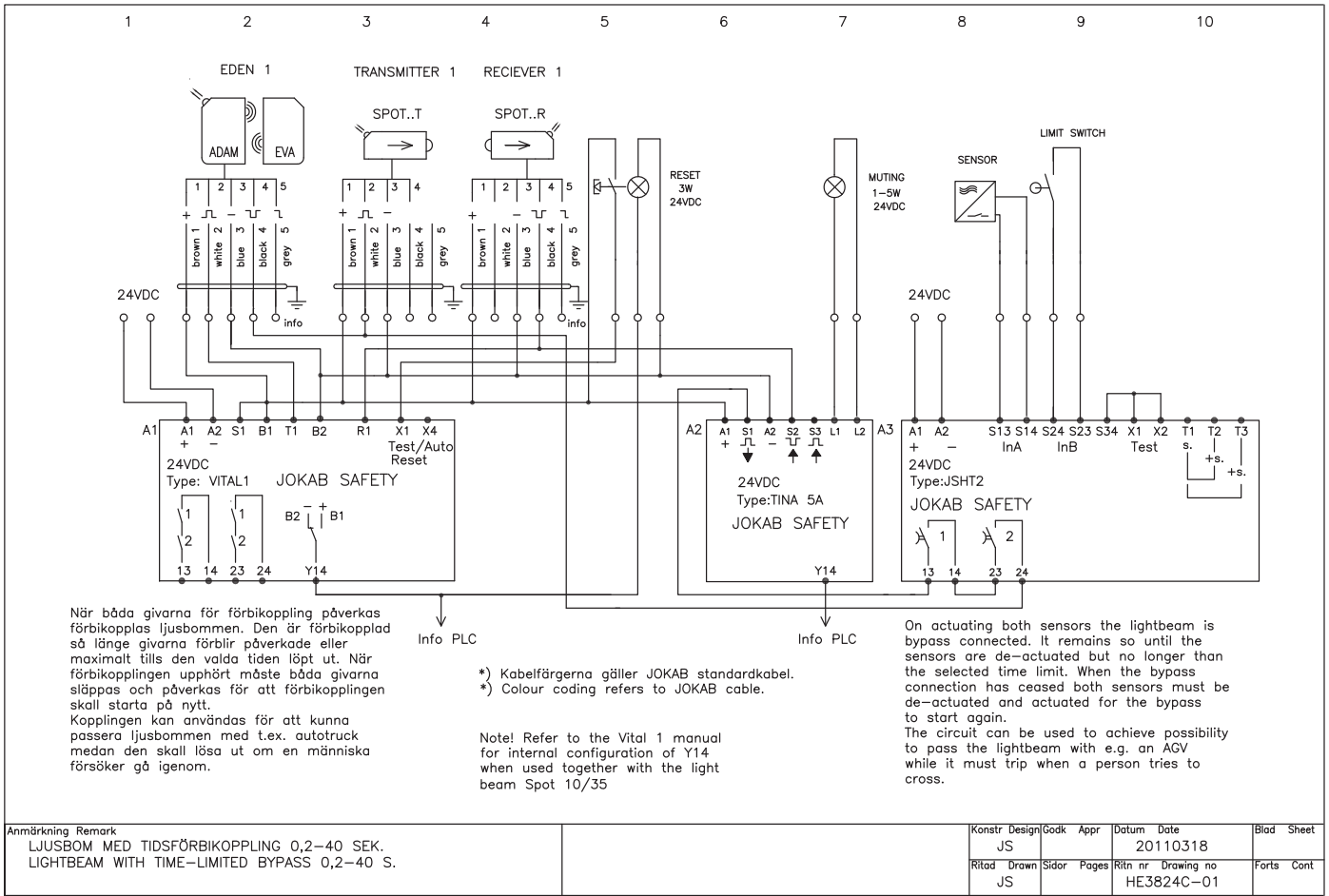

# HE3824E Lightbeams with time-limited bypass 0.2-40 s

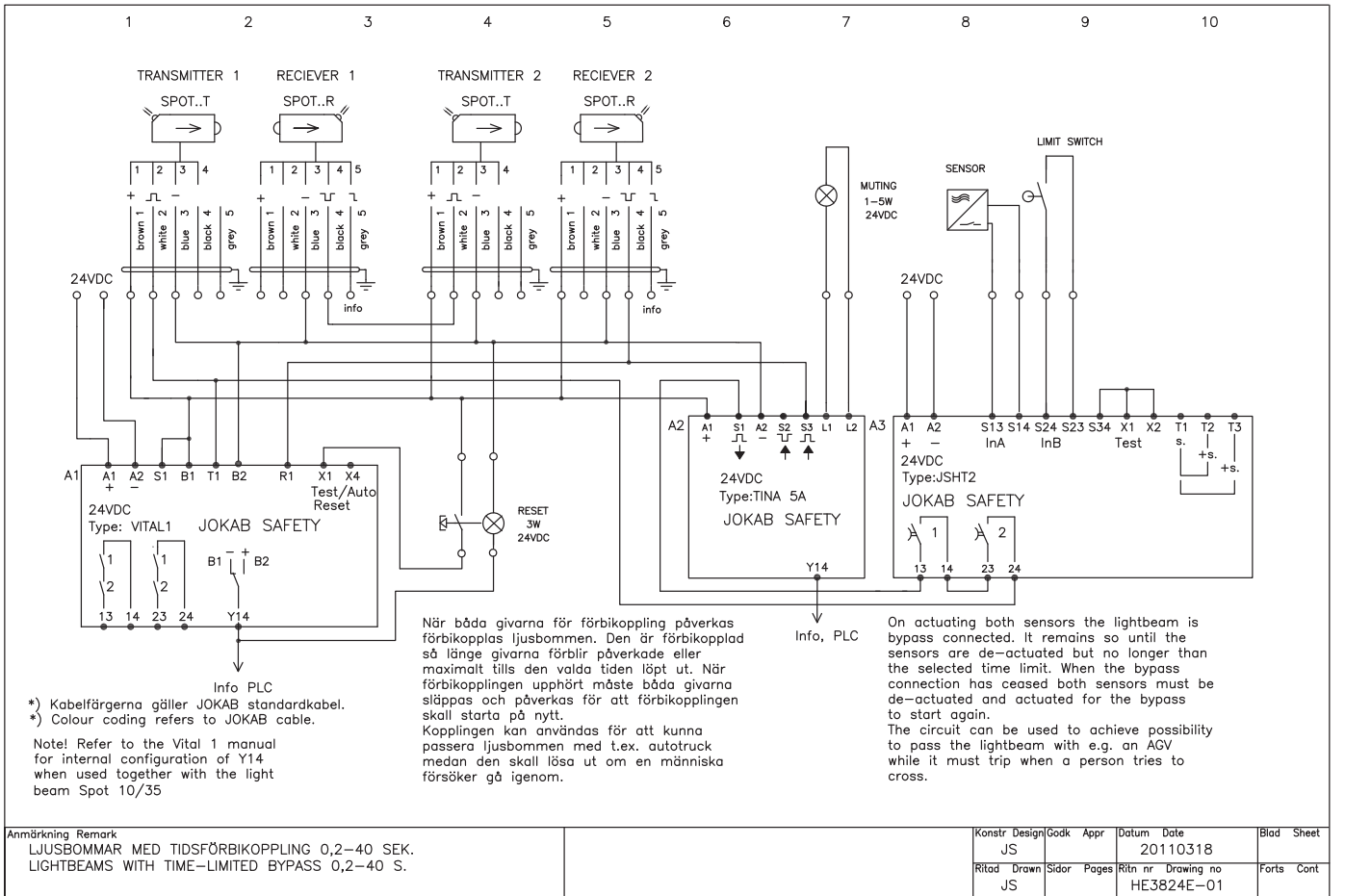

# HG7636B Focus light grid/curtain with three-position device

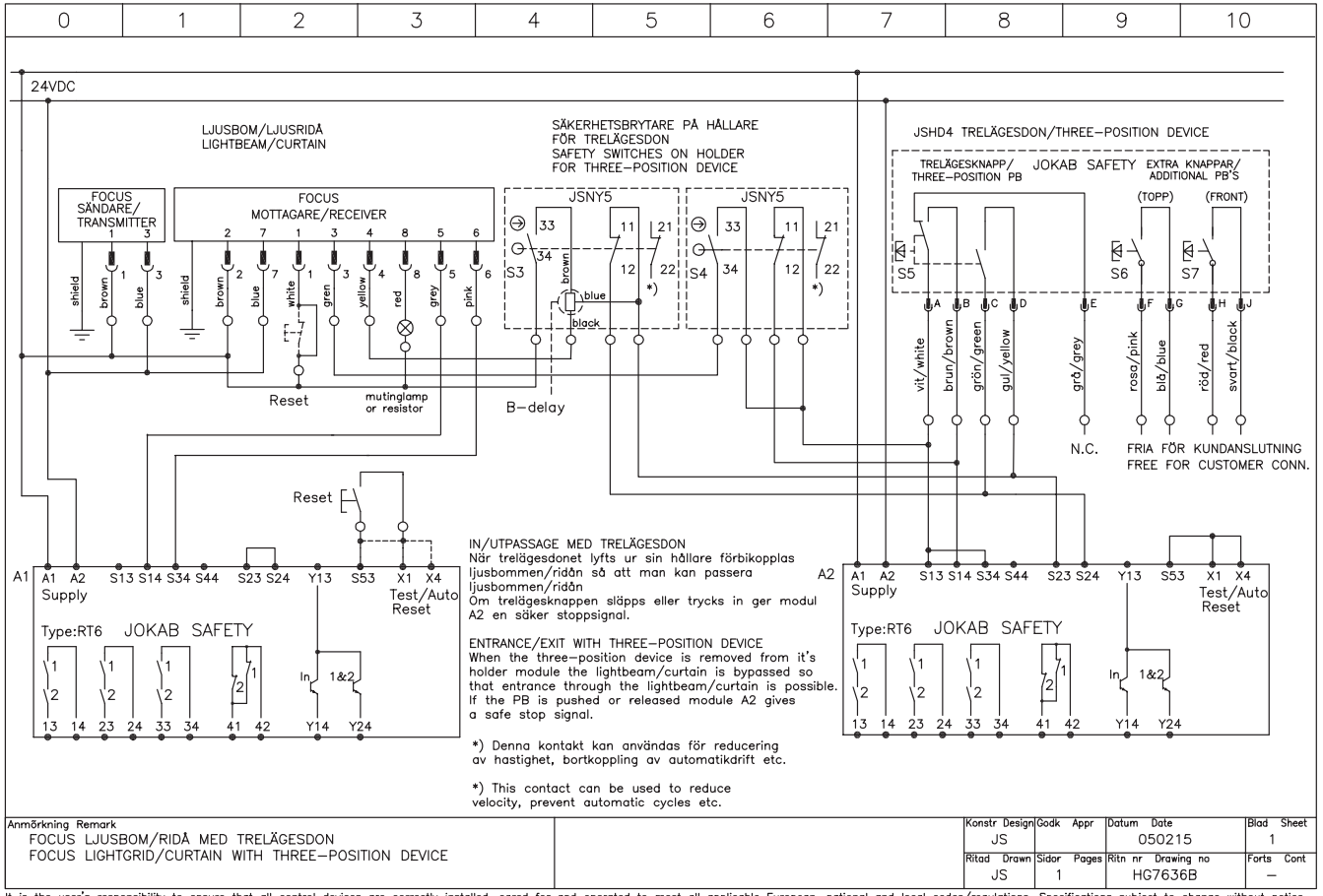

# HG7611A Interlocked door with RT6 and pre-reset

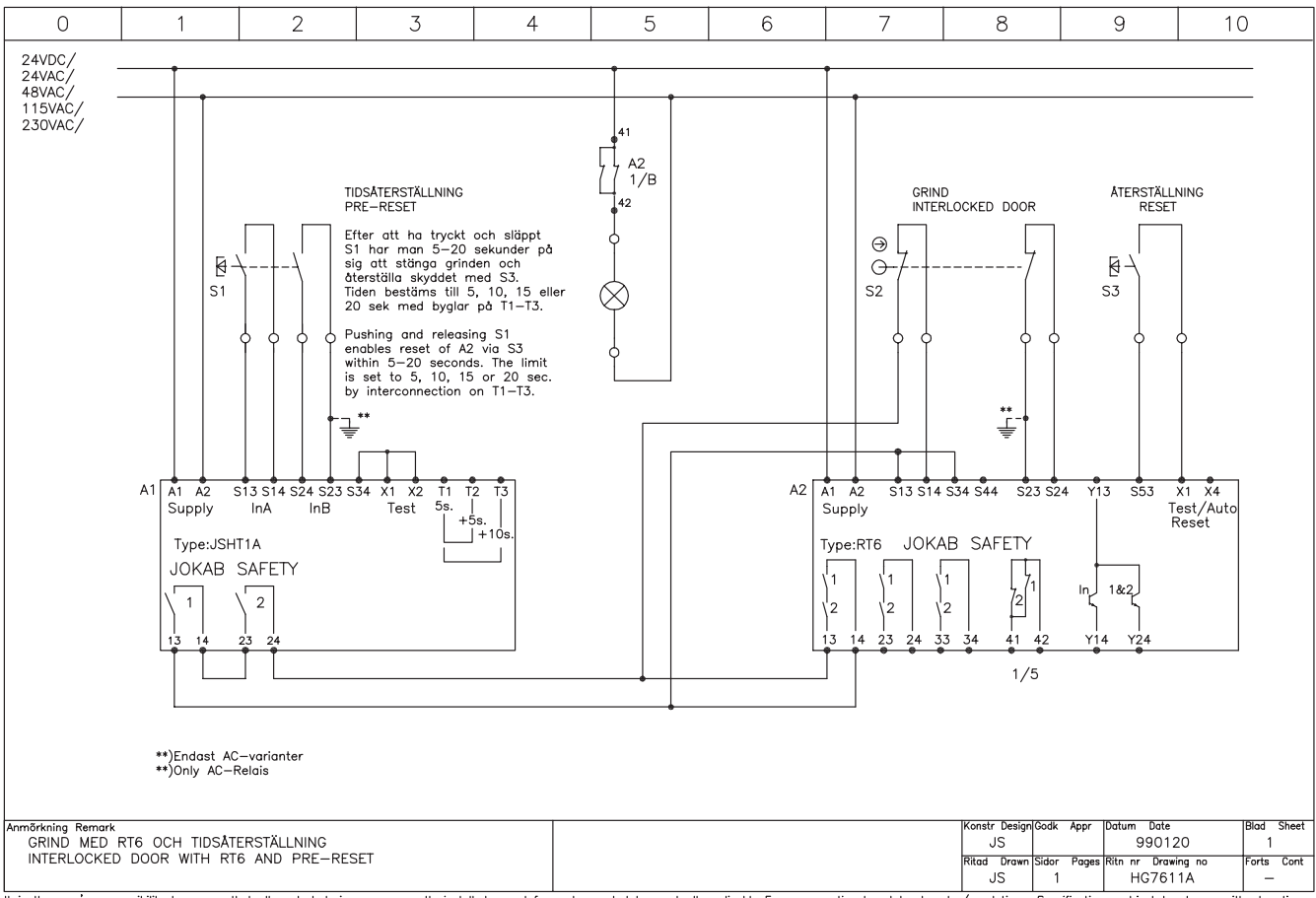

# HG7636A Interlocked door with three-position device

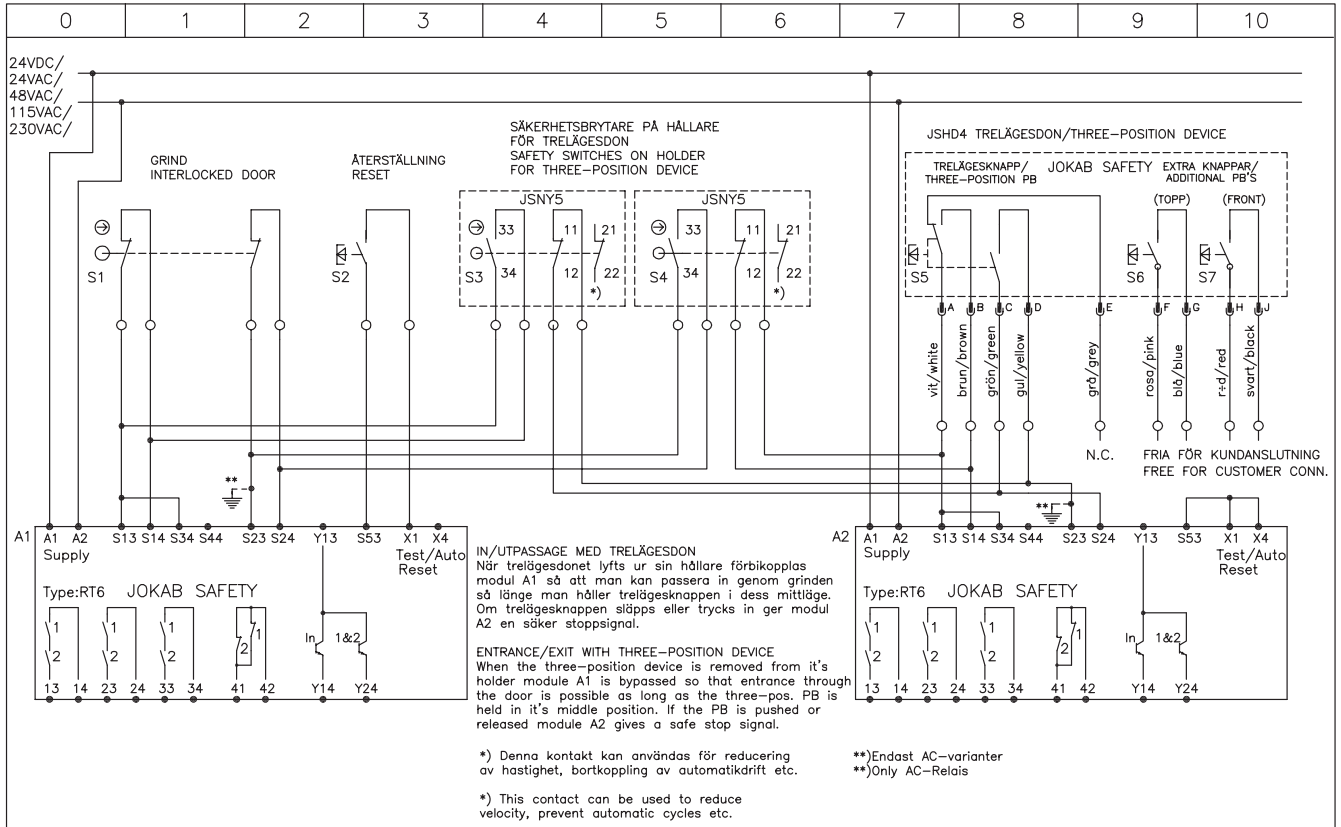

Anmärkning Remark GRIND MED TRELÄGESDON INTERLOCKED DOOR WITH THREE-POSITION DEVICE	Konstr Design	Godk	Appr	Datum Date	Blad Sheet
	Ritad Drawn	Sidor Pages	Ritn nr Drawing no	040311 HG7636A	1 -

It is the user's responsibility to ensure that all control devices are correctly installed, cared for and operated to meet all applicable European, national and local codes/regulations. Specifications subject to change without notice.

# HG7646A Interlocked door with three-position device and time-limited entrance/exit

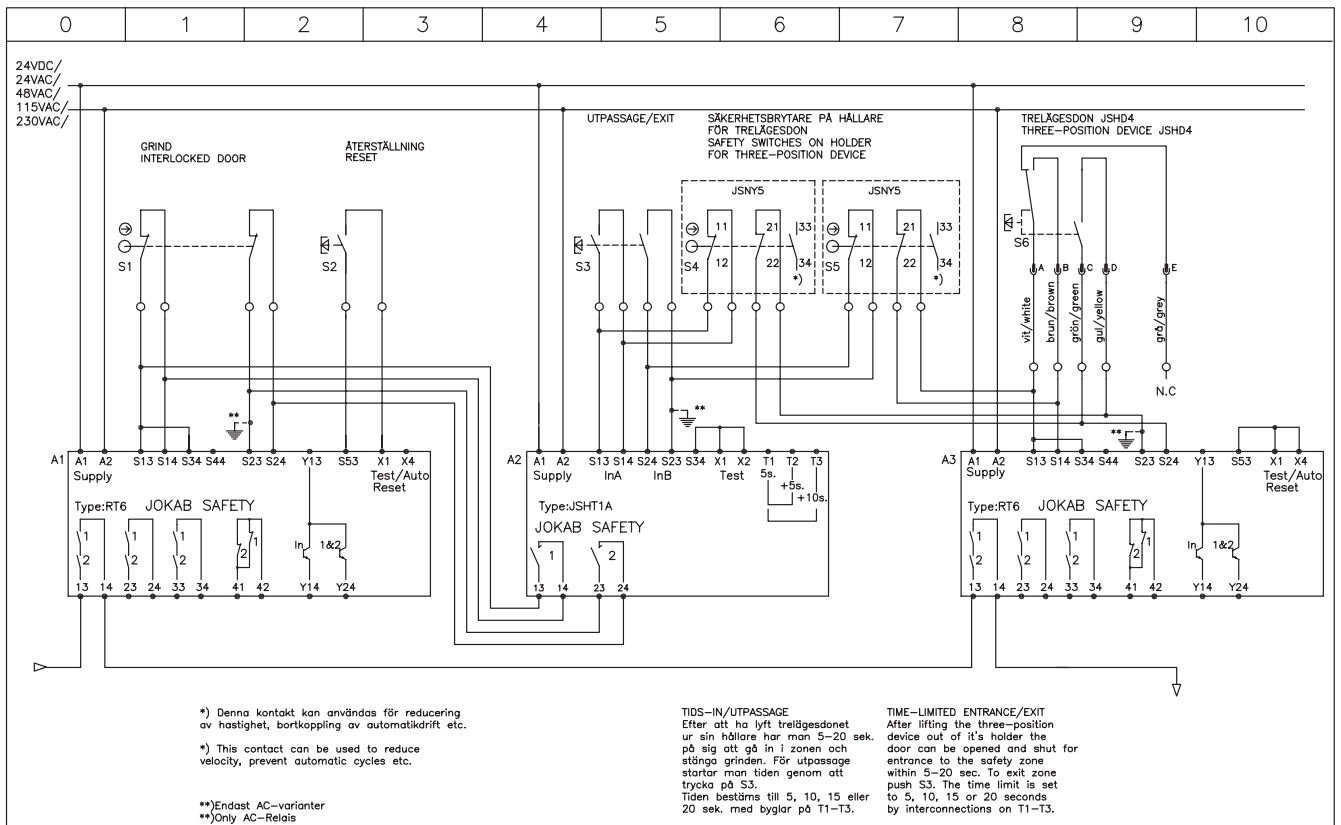

Anmärkning Remark GRIND MED TRELÄGESDON OCH TIDS-IN/UTPASSAGE INTERLOCKED DOOR WITH THREE-POSITION DEVICE AND TIME-LIMITED ENTRANCE/EXIT	Konstr Design	Godk	Appr	Datum Date	Blad Sheet
	Ritad Drawn	Sidor Pages	Ritn nr Drawing no	040311 HG7646A	1 -

It is the user's responsibility to ensure that all control devices are correctly installed, cared for and operated to meet all applicable European, national and local codes/regulations. Specifications subject to change without notice.

# HG7654A Interlocked door with RT6 and output expansion JSR1T

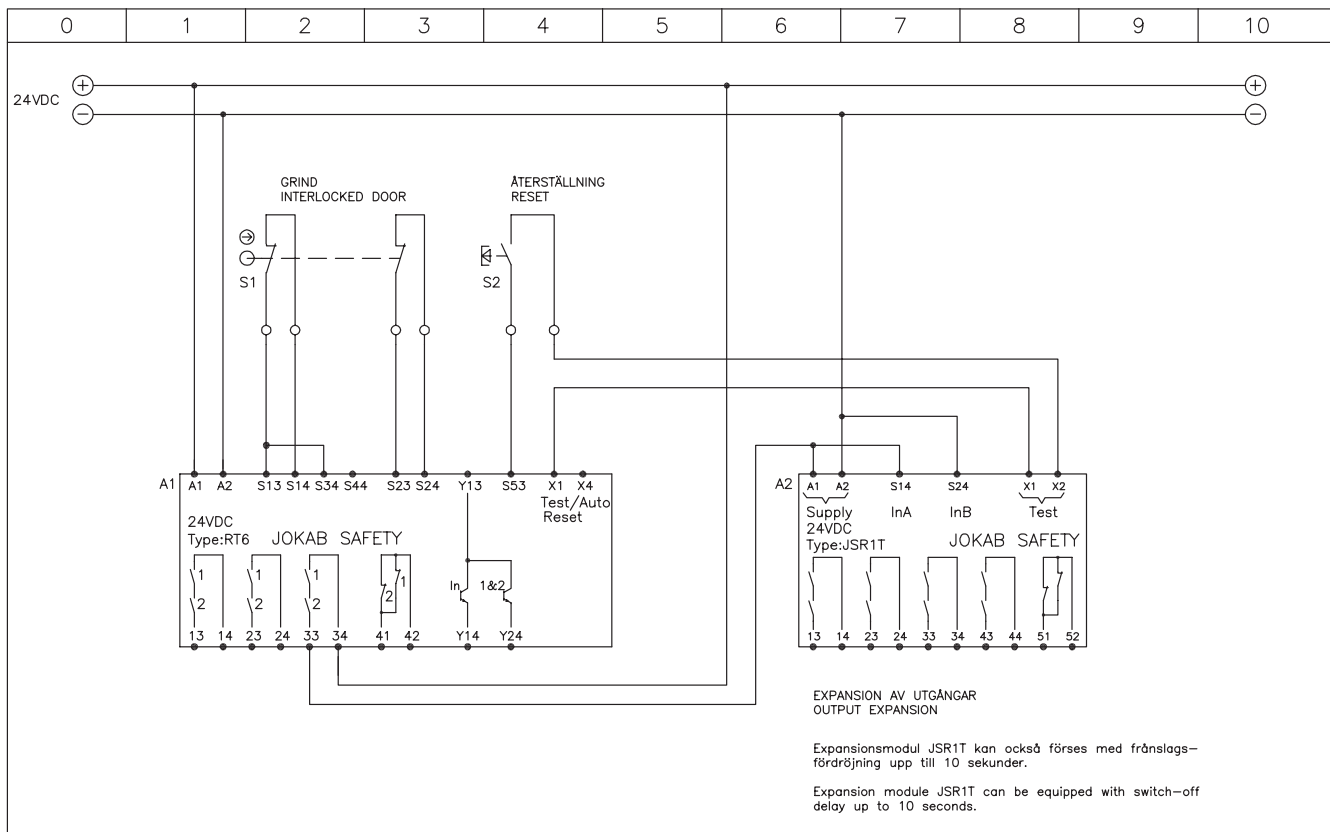

Anmärkning Remark GRIND MED RT6 OCH EXPANSION JSR1T INTERLOCKED DOOR WITH RT6 AND OUTPUT EXPANSION JSR1T	Konstr Design	Godk Appr	Datum Date	Blad Sheet
	Ritad Drawn	Sidor Pages	Ritn nr Drawing no	Forts Cont
	JS	JS	990120	1
	1	1	HG7654A	-

It is the user's responsibility to ensure that all control devices are correctly installed, cared for and operated to meet all applicable European, national and local codes/regulations. Specifications subject to change without notice.

# HG7658A Interlocked door with RT6 and output expansion JSR2A

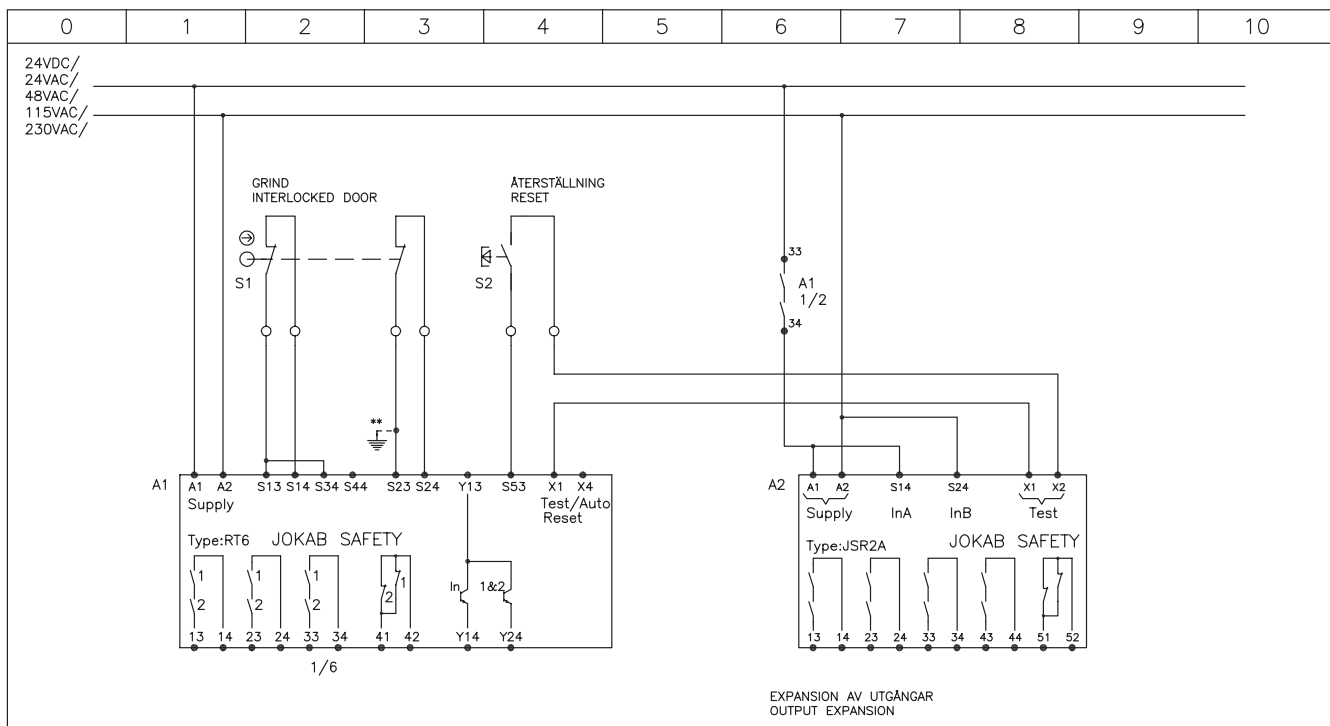

\*\*Endast AC-varianter  
\*\*Only AC-Relais

Anmärkning Remark GRIND MED RT6 OCH EXPANSION JSR2A INTERLOCKED DOOR WITH RT6 AND OUTPUT EXPANSION JSR2A	Konstr Design	Godk Appr	Datum Date	Blad Sheet
	Ritad Drawn	Sidor Pages	Ritn nr Drawing no	Forts Cont
	JS	JS	990120	1
	1	1	HG7658A	-

It is the user's responsibility to ensure that all control devices are correctly installed, cared for and operated to meet all applicable European, national and local codes/regulations. Specifications subject to change without notice.

# HG7673A Interlock switch JSNY8 with RT6

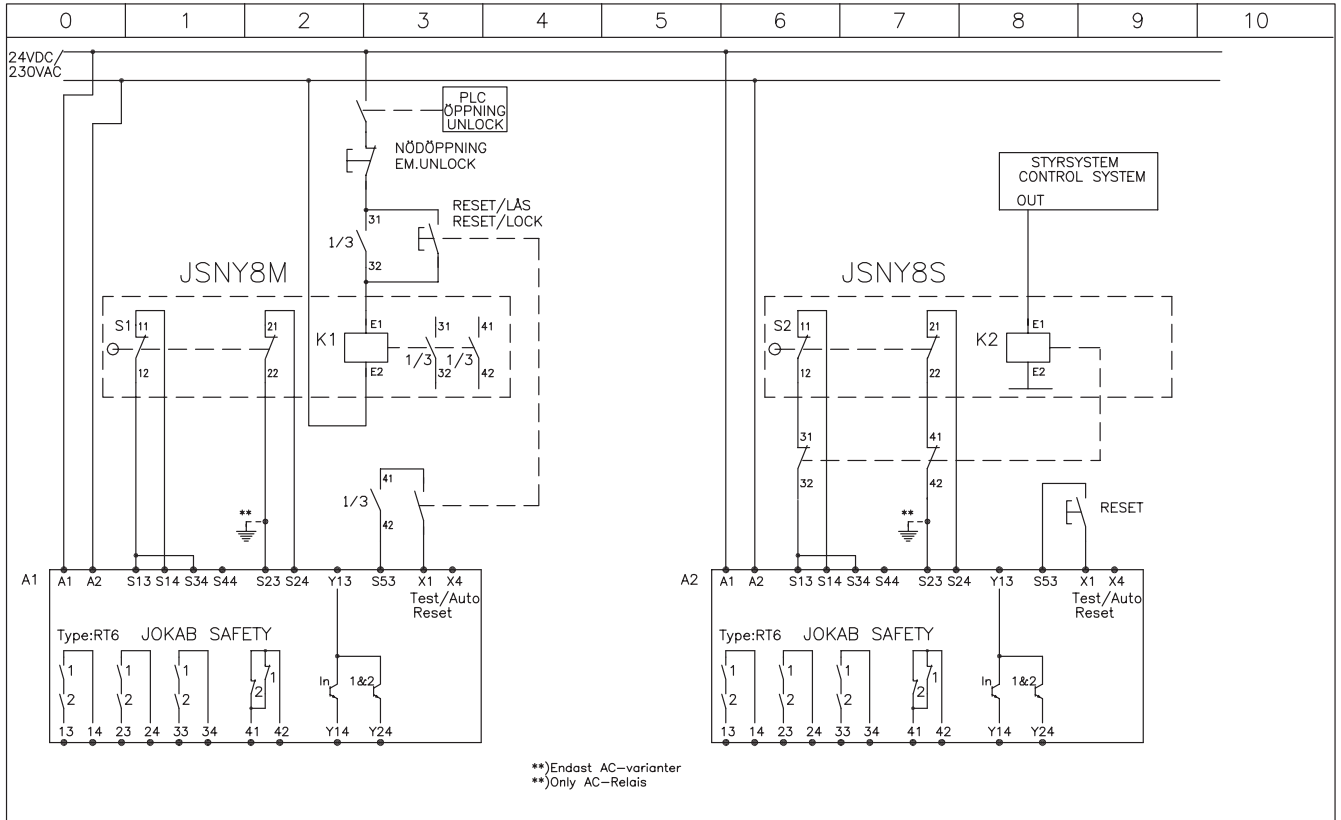

\*\*Endast AC-varianter  
\*\*Only AC-Relais

Anmärkning Remark NYCKELBRYTARE JSNY8 MED RT6 INTERLOCK SWITCH JSNY8 WITH RT6	Konstr JS	Design	Godk	Appr	Datum 990120	Date	Blad 1	Sheet
	Ritad JS	Drawn	Sidor 1	Pages	Ritn nr HG7673A	Drawing no	Forts -	Cont

It is the user's responsibility to ensure that all control devices are correctly installed, cared for and operated to meet all applicable European, national and local codes/regulations. Specifications subject to change without notice.

# HG7674A Safety interlock switch JSNY9M/MLA with RT6

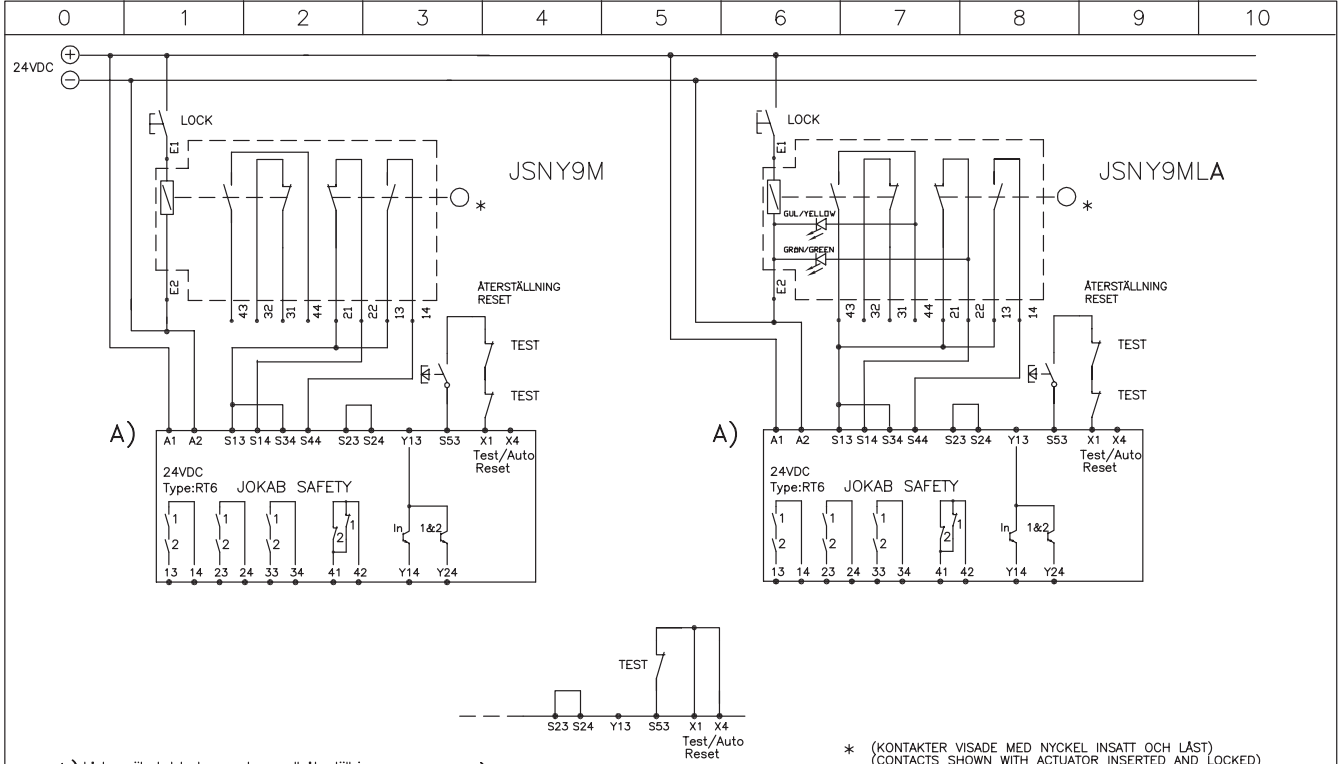

A) Lösbar säkerhetsbrytare med manuell återställning samt övervakning av yttre kontaktorer/reläer  
Safety interlock switch with manual reset and monitoring of external contactors/relays

B) med automatisk återställning.  
with automatic reset.

\* (KONTAKTER VISADE MED NYCKEL INSATT OCH LÅST)  
(CONTACTS SHOWN WITH ACTUATOR INSERTED AND LOCKED)

Anmärkning Remark LÅSBAR SÄKERHETSBRYTARE JSNY9M/MLA MED RT6 SAFETY INTERLOCK SWITCH JSNY9M/MLA WITH RT6	Konstr JS	Design	Godk	Appr	Datum 040311	Date	Blad 1	Sheet
	Ritad JS	Drawn	Sidor 1	Pages	Ritn nr HG7674A	Drawing no	Forts -	Cont

It is the user's responsibility to ensure that all control devices are correctly installed, cared for and operated to meet all applicable European, national and local codes/regulations. Specifications subject to change without notice.



# HG7674B Safety interlock switch JSNY9S/SLA with RT6

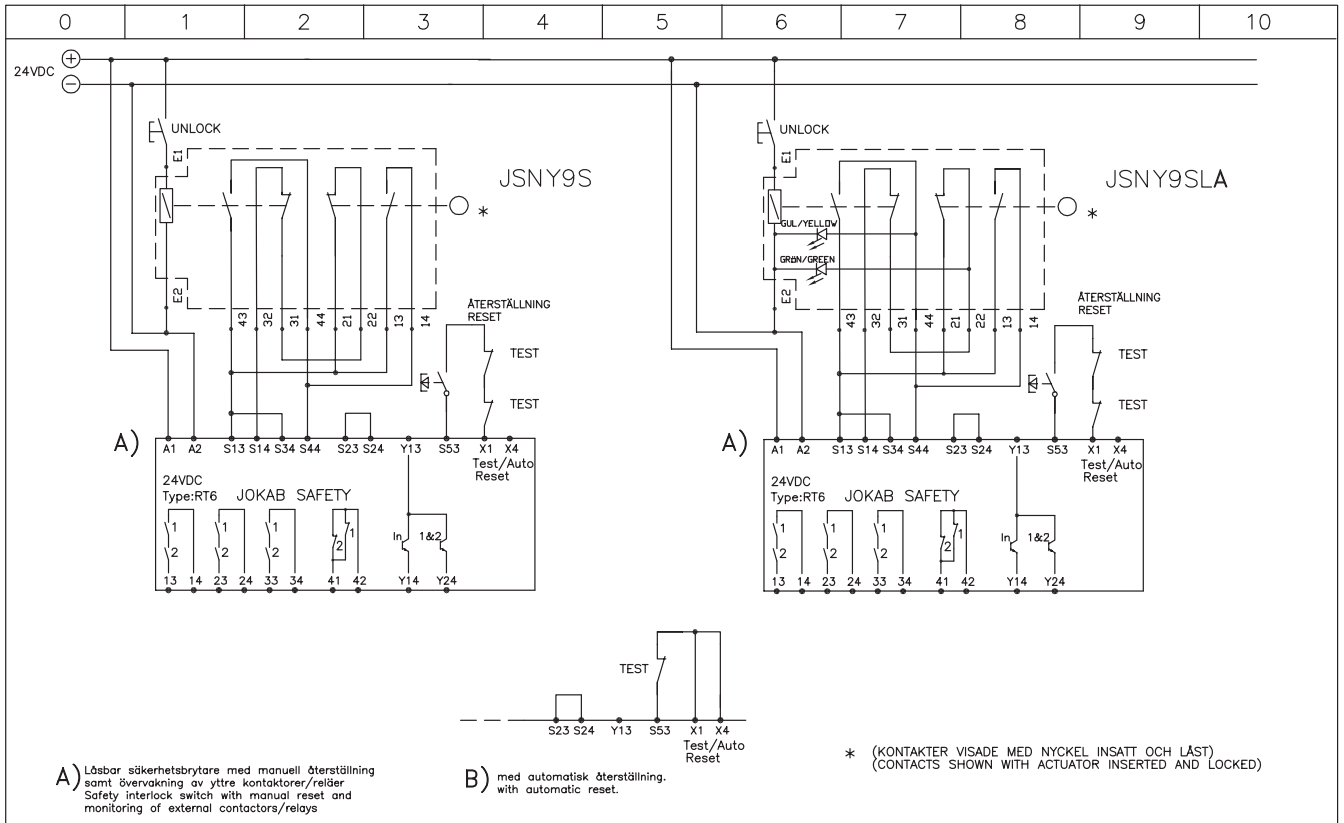

Anmärkning Remark LÄSBAR SÄKERHETSBRYTARE JSNY9S/SLA MED RT6 SAFETY INTERLOCK SWITCH JSNY9S/SLA WITH RT6	Konstr Design	Godk Appr	Datum Date	Blad Sheet
	JS		991209	1
	Ritad Drawn	Sidor Pages	Ritn nr Drawing no	Forts Cont
	JS	1	HG7674B	-

It is the user's responsibility to ensure that all control devices are correctly installed, cared for and operated to meet all applicable European, national and local codes/regulations. Specifications subject to change without notice.

# HH000C Three-position device JSHD4 with various safety controllers

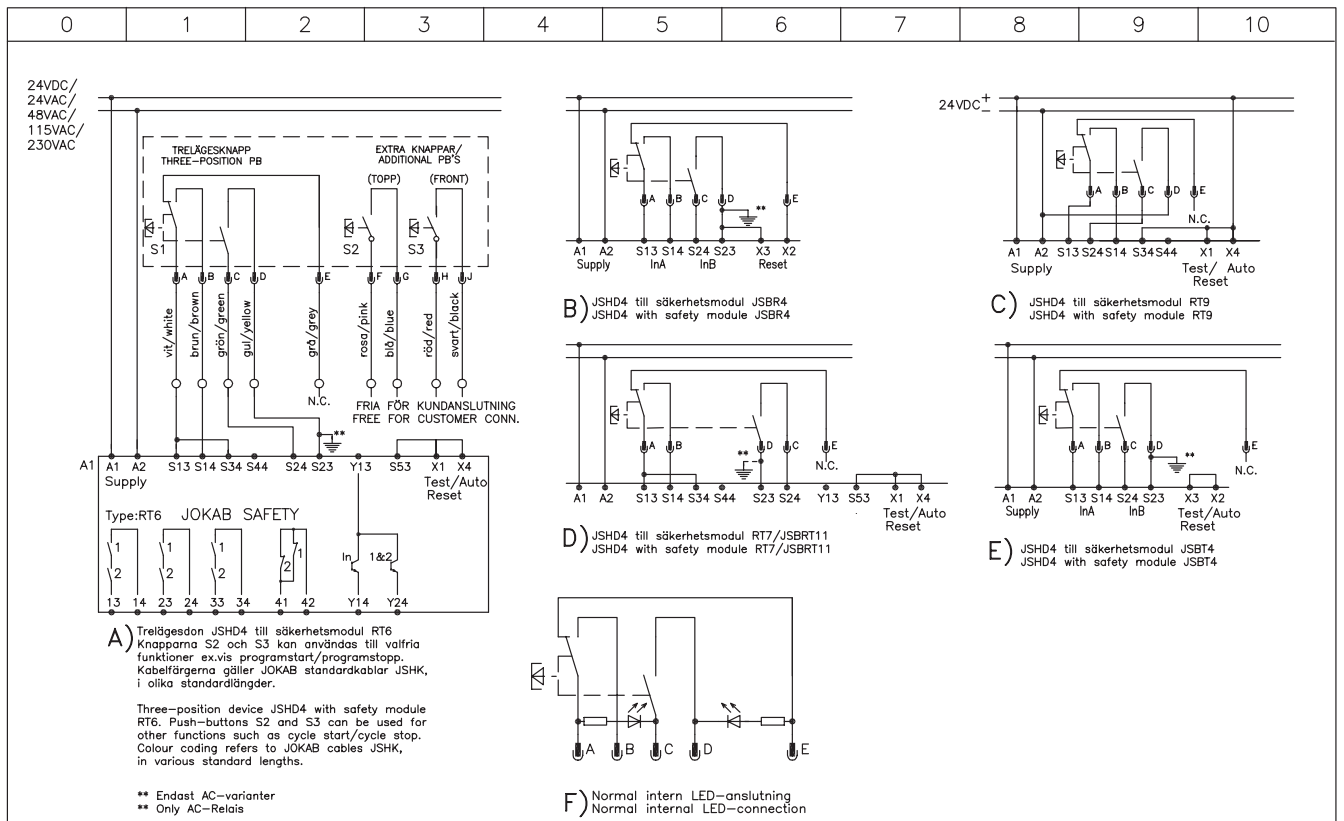

Anmärkning Remark TRELÄGESDON JSHD4 TILL OLIKA SÄKERHETSMODULER THREE-POSITION DEVICE JSHD4 WITH VARIOUS SAFETY MODULES	Konstr Design	Godk Appr	Datum Date	Blad Sheet
	JS		050112	1
	Ritad Drawn	Sidor Pages	Ritn nr Drawing no	Forts Cont
	JS	1	HH000C	-

It is the user's responsibility to ensure that all control devices are correctly installed, cared for and operated to meet all applicable European, national and local codes/regulations. Specifications subject to change without notice.

# HI8552A Connection examples JSHT2 intermittent running

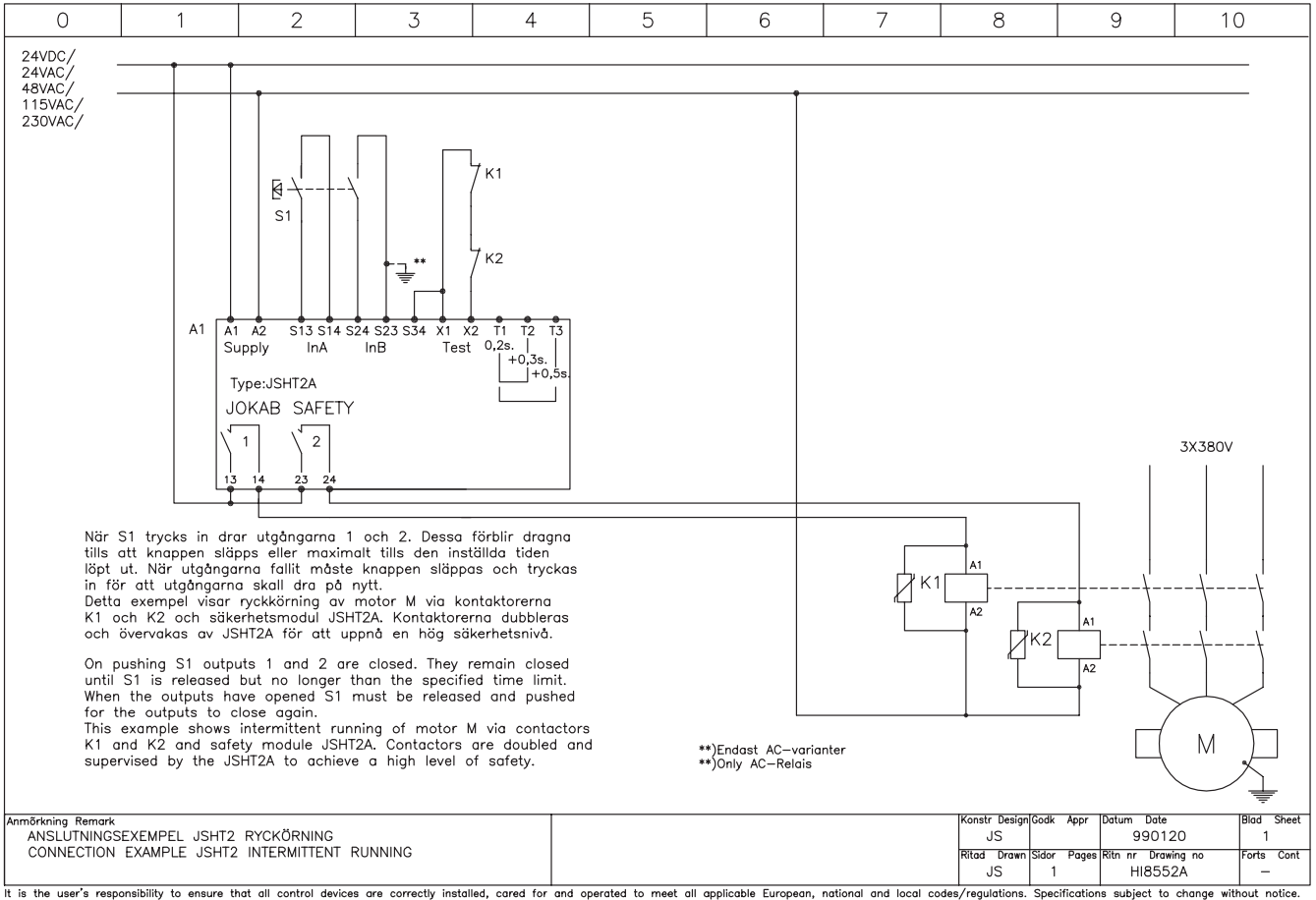

# HK7600A Safety mat/Contact strip with RT6

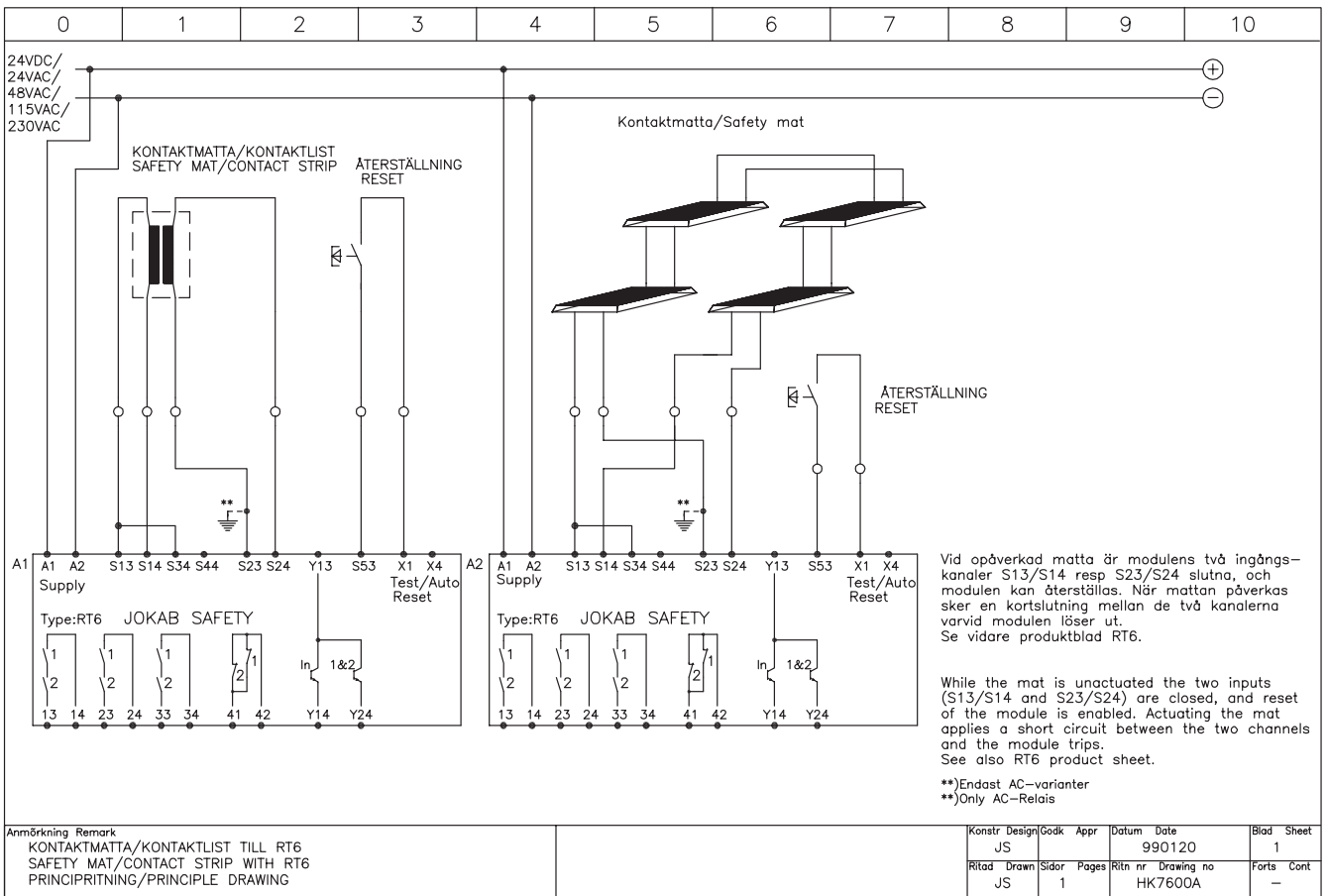

# HL7600B Several JSNY7 connected to one RT6 with unique indication

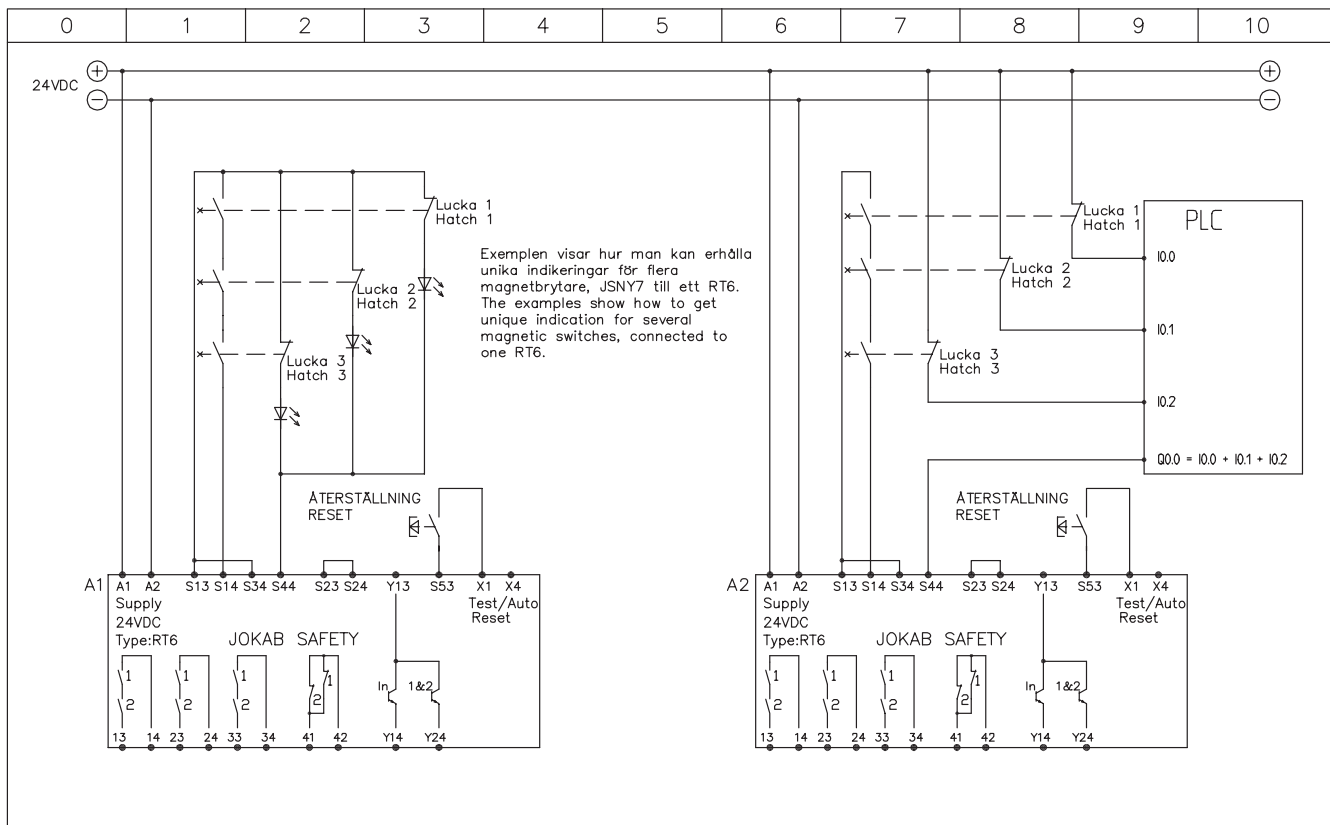

Exemplet visar hur man kan erhålla unika indikeringar för flera magnetbrytare, JSNY7 till ett RT6. The examples show how to get unique indication for several magnetic switches, connected to one RT6.

Anmärkning Remark FLERA JSNY7 TILL ETT RT6 MED UNIKA INDIKERINGAR SEVERAL JSNY7 CONNECTED TO ONE RT6 WITH UNIQUE INDICATION	Konstr Design	Godk Appr	Datum Date	Blad Sheet
	Ritad Drawn	Sidor Pages	Ritn nr Drawing no	Forts Cont
	JS	1	990120	1
	JS	1	HL7600B	-

It is the user's responsibility to ensure that all control devices are correctly installed, cared for and operated to meet all applicable European, national and local codes/regulations. Specifications subject to change without notice.

# HM0000A Magnetic switch JSNY7 with various safety controllers

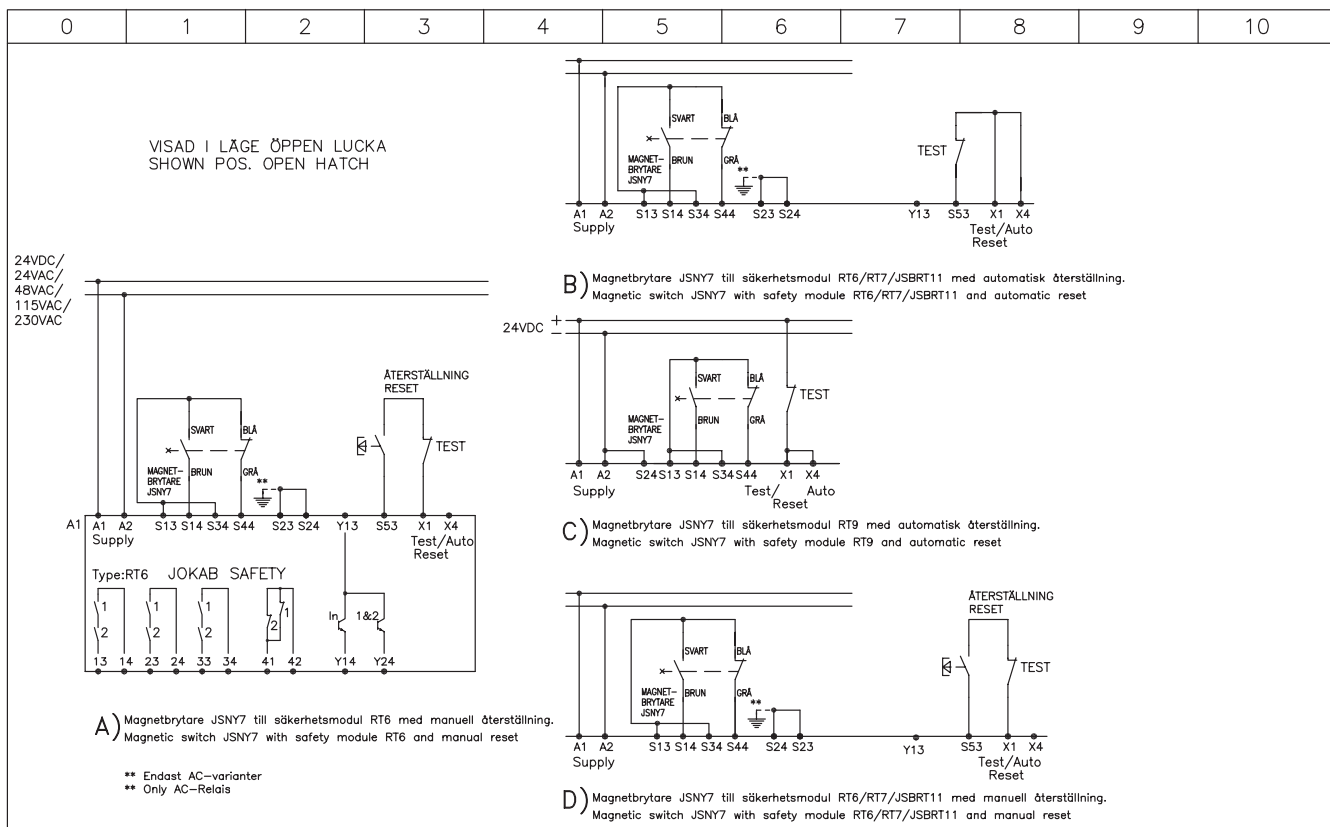

A) Magnetbrytare JSNY7 till säkerhetsmodul RT6 med manuell återställning. Magnetic switch JSNY7 with safety module RT6 and manual reset

B) Magnetbrytare JSNY7 till säkerhetsmodul RT6/RT7/JSBRT11 med automatisk återställning. Magnetic switch JSNY7 with safety module RT6/RT7/JSBRT11 and automatic reset

C) Magnetbrytare JSNY7 till säkerhetsmodul RT9 med automatisk återställning. Magnetic switch JSNY7 with safety module RT9 and automatic reset

D) Magnetbrytare JSNY7 till säkerhetsmodul RT6/RT7/JSBRT11 med manuell återställning. Magnetic switch JSNY7 with safety module RT6/RT7/JSBRT11 and manual reset

\*\* Endast AC-varianter  
\*\* Only AC-Relais

Anmärkning Remark MAGNETBRYTARE JSNY7 TILL OLIKA SÄKERHETSMODULER MAGNETIC SWITCH JSNY7 WITH VARIOUS SAFETY MODULES	Konstr Design	Godk Appr	Datum Date	Blad Sheet
	Ritad Drawn	Sidor Pages	Ritn nr Drawing no	Forts Cont
	JS	1	991209	1
	JS	1	HM0000A	-

It is the user's responsibility to ensure that all control devices are correctly installed, cared for and operated to meet all applicable European, national and local codes/regulations. Specifications subject to change without notice.

# HN7660A Delayed outputs RT6 with output expansion JSR3T and RT7

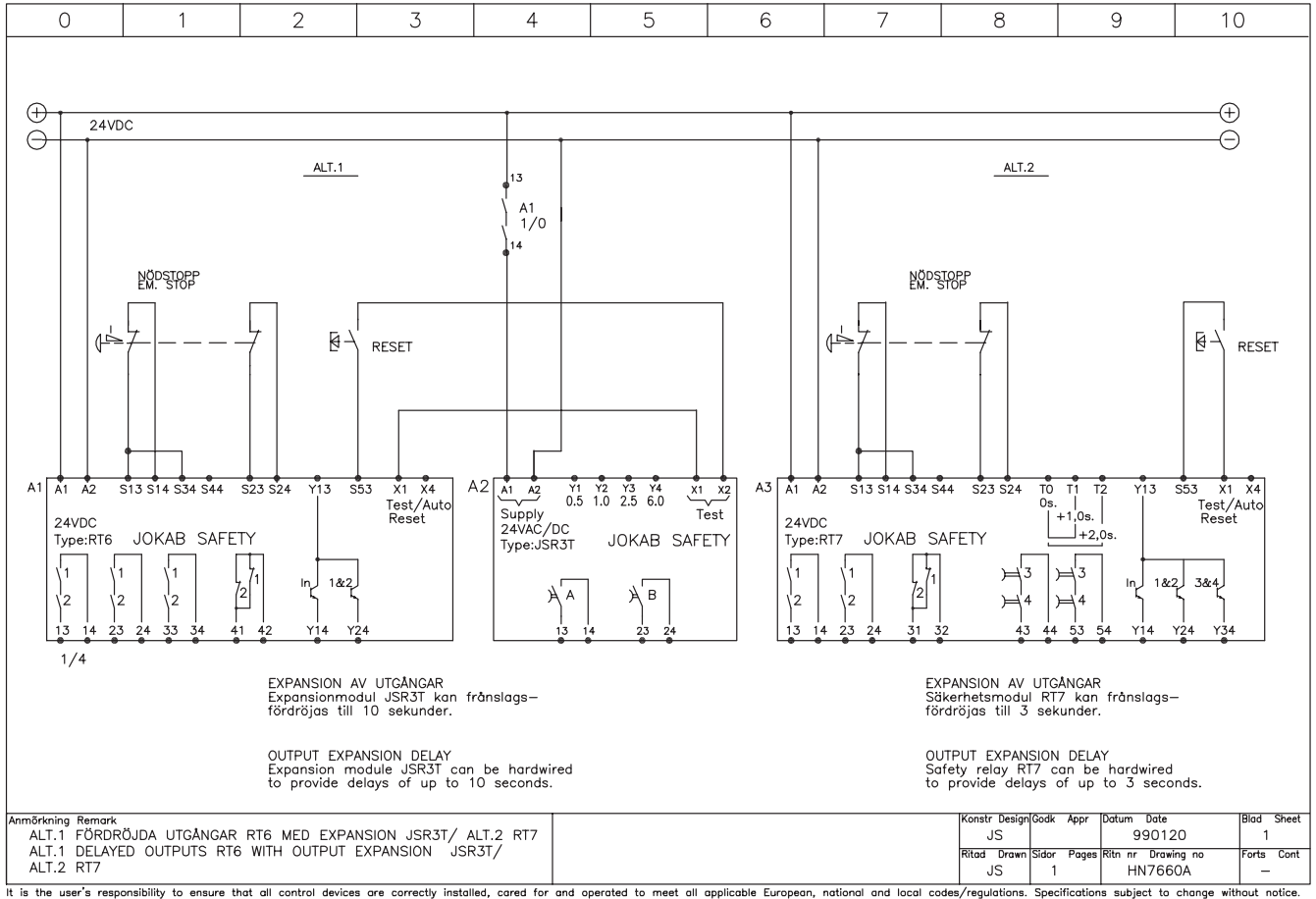

# HP7600A Machine control - Isolation of PLC inputs and outputs

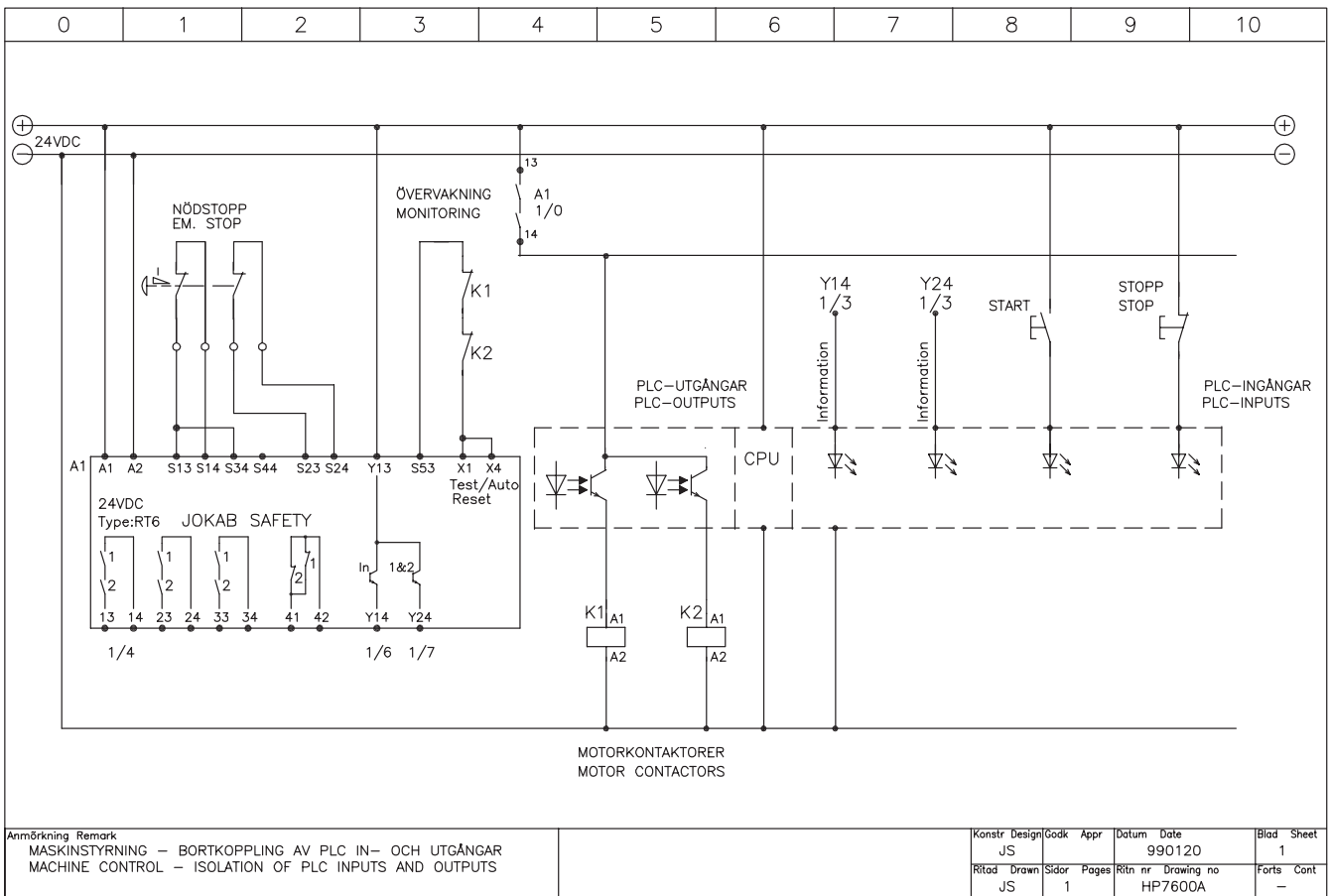

# HP7600B Machine control-Isolation of PLC outputs

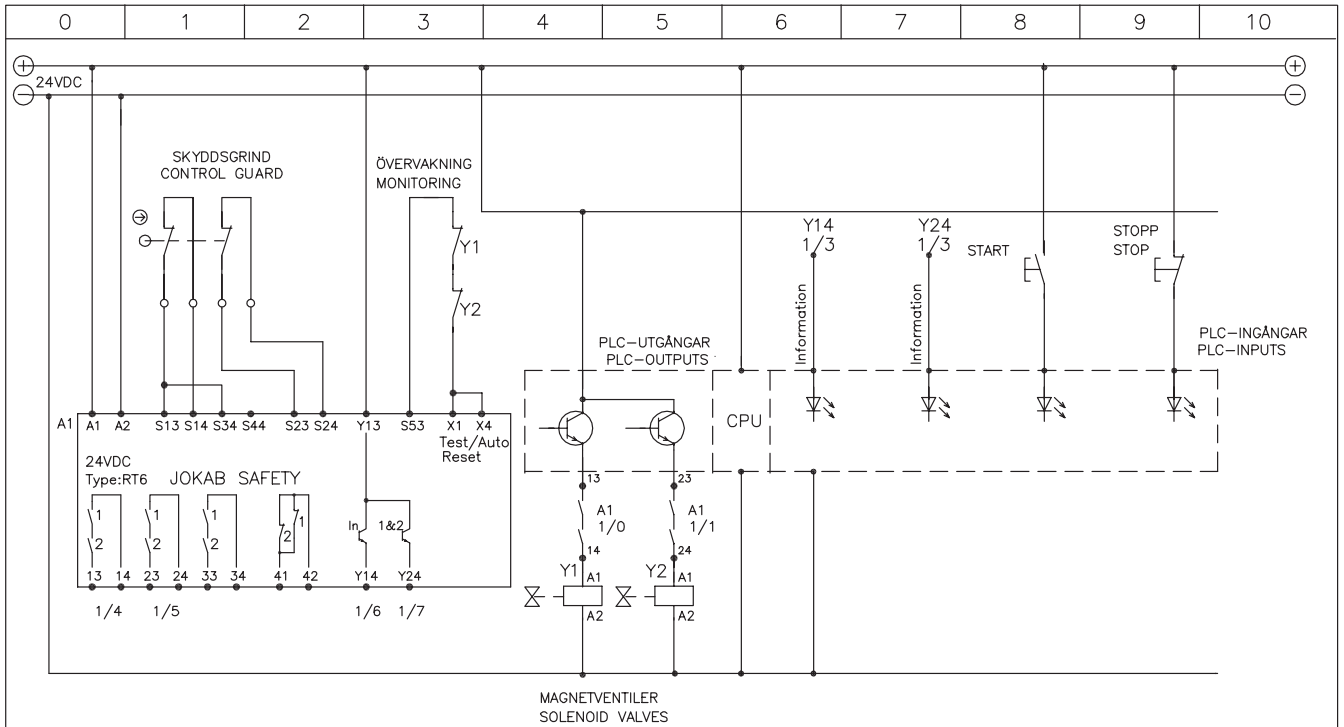

Högriskapplikation t.ex. manuellt betjänade pressar.  
High risk application for example manually operated presses.

Anmärkning Remark MASKINSTYRNING - BORTKOPPLING AV PLC-STYRDA UTGÅNGAR MACHINE CONTROL - ISOLATION OF PLC OUTPUTS	Konstr Design	Gödk	Appr	Datum Date	Blad Sheet
	JS			990120	1
	Ritad Drawn	Sidor Pages	Ritn nr Drawing no	Forts Cont	
	JS	1	HP7600B	-	

It is the user's responsibility to ensure that all control devices are correctly installed, cared for and operated to meet all applicable European, national and local codes/regulations. Specifications subject to change without notice.

# HR7200B Focus light curtain/beam

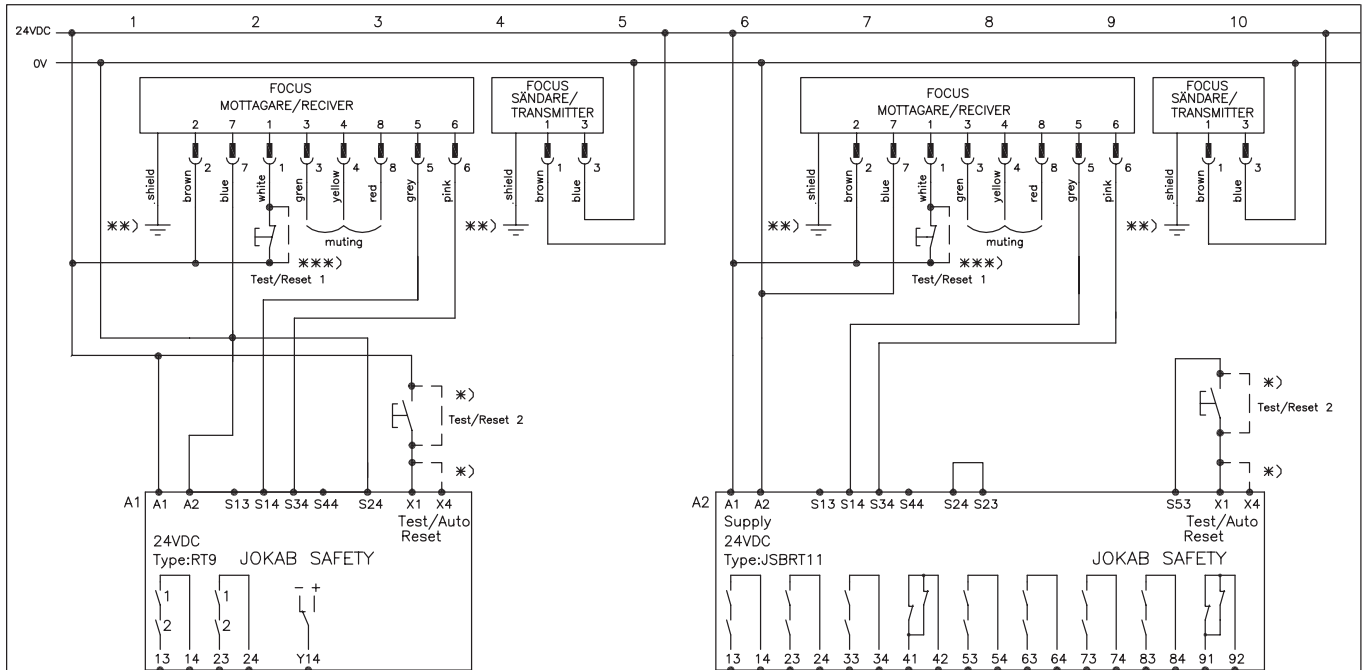

\*\*\*)Återställning av ljusrida/ljusbom  
För mer information se Focus manual  
\*\*\*)Reset of the Safety Light Curtain/Barrier  
For more information se The Focus Manual

\*)Automatisk återställning/Automatic reset (säkerhetsrelä/safetyrelays)  
\*\*)Skärmen jordas endast i skåpsänden.  
\*\*\*)The cable shield should only be connected at the cabinet end.

Anmärkning Remark FOCUS LJUSRIDA/LJUSBOM FOCUS LIGHT CURTAIN/BEAM	Konstr Design	Gödk	Appr	Datum Date	Blad Sheet
	JS			040311	
	Ritad Drawn	Sidor Pages	Ritn nr Drawing no	Forts Cont	
	JS	1	HR7200B		

It is the user's responsibility to ensure that all control devices are correctly installed, cared for and operated to meet all applicable European, national and local codes/regulations. Specifications subject to change without notice.

# HR7800B Focus lightbeam/curtain

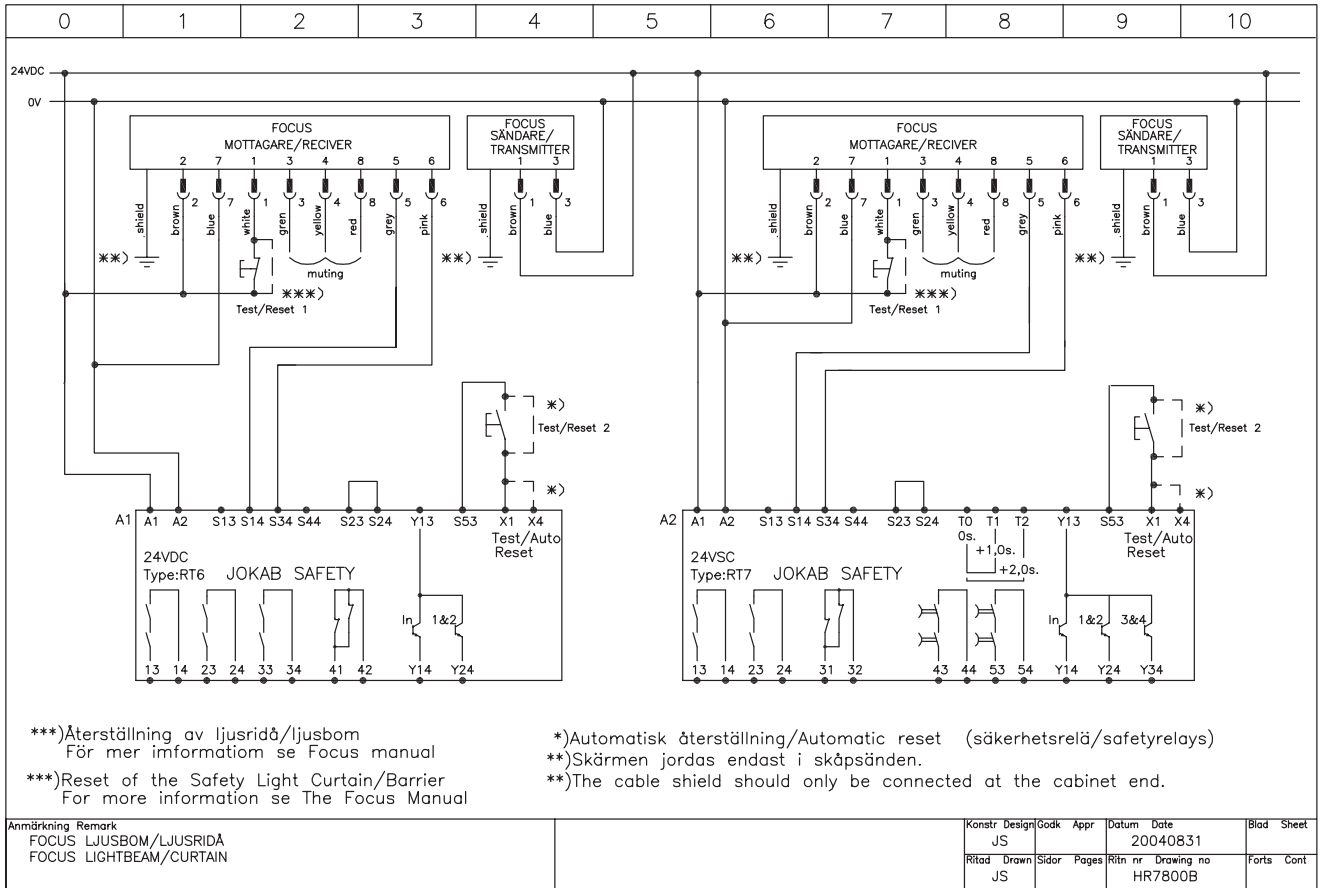

It is the user's responsibility to ensure that all control devices are correctly installed, cared for and operated to meet all applicable European, national and local codes/regulations. Specifications subject to change without notice.

# HT5400A Two-hand device with safety relay JSBR4

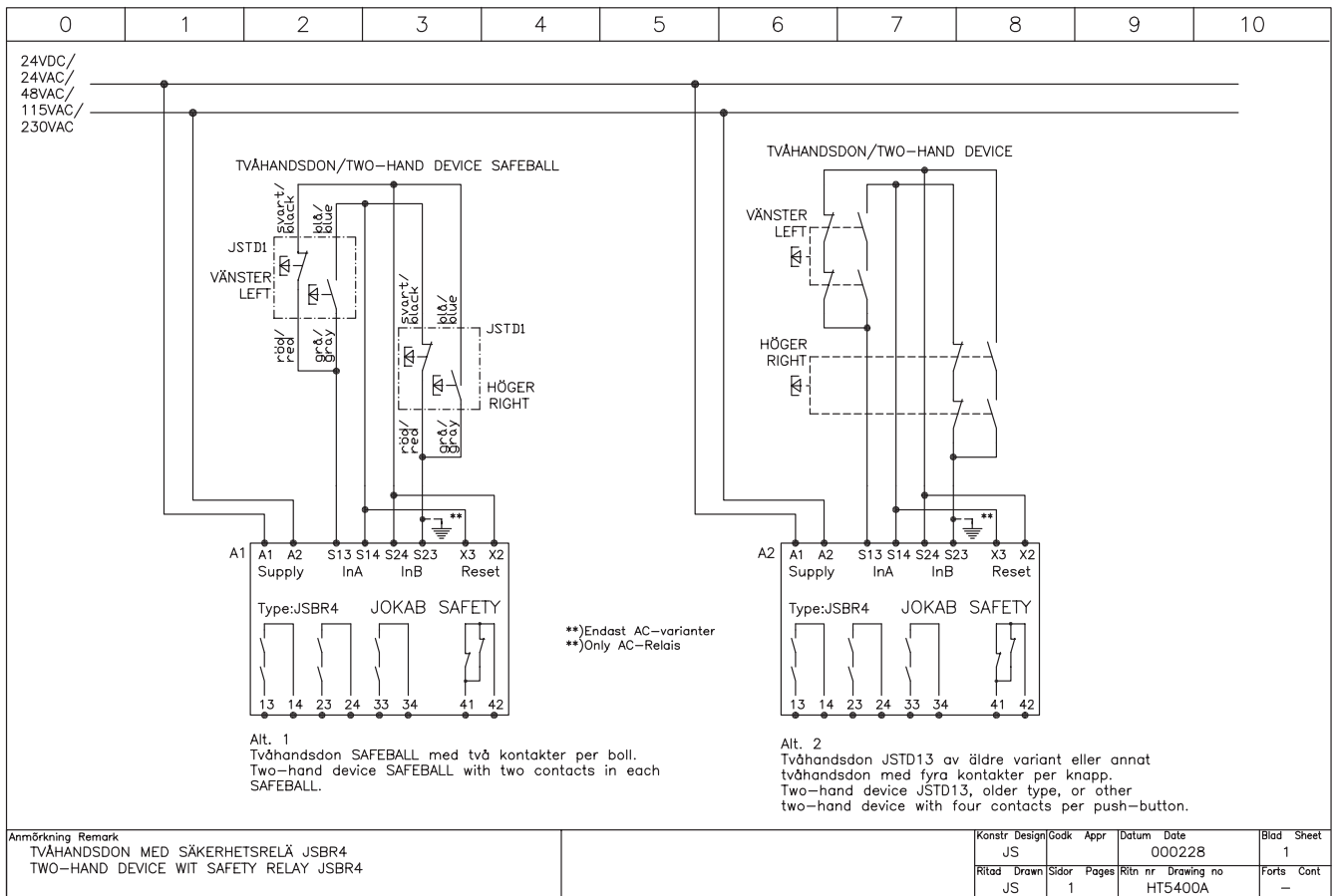

It is the user's responsibility to ensure that all control devices are correctly installed, cared for and operated to meet all applicable European, national and local codes/regulations. Specifications subject to change without notice.



# HB0008A Focus light curtain/light beam connected to an RT9 with the aid of a M12-3D

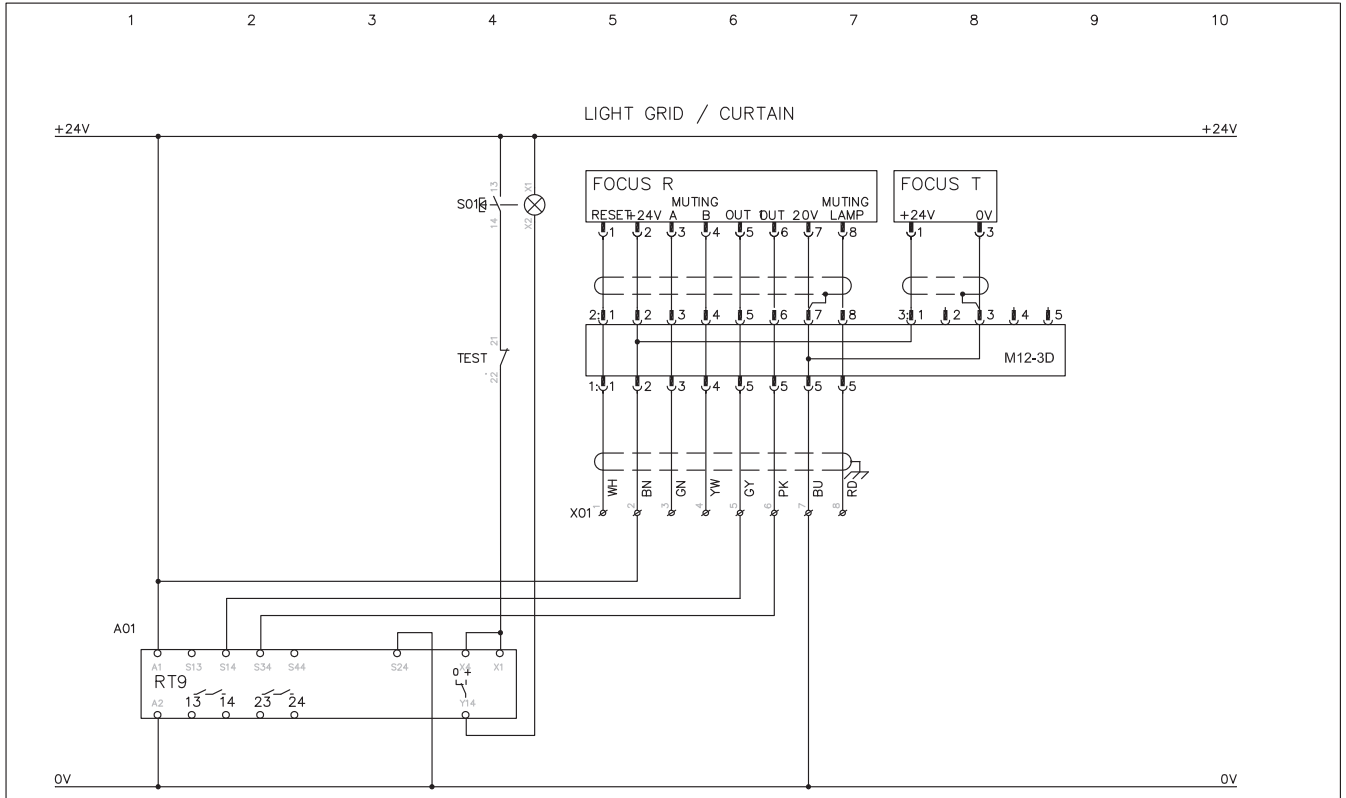

Anmärkning Remark	JS				Datum Date		Blad Sheet	
	JS				20080402			
	Ritad Drawn		Sidor Pages		Ritn nr Drawing no		Forts Cont	

FOCUS WITH M12-3D TO RT9

Konstr Design	Godk Appr	Datum Date	Blad Sheet
JS		20080402	
Ritad Drawn	Sidor Pages	Ritn nr Drawing no	Forts Cont
JS		HB0008A	

It is the user's responsibility to ensure that all control devices are correctly installed, cared for and operated to meet all applicable European, national and local codes/regulations. Specifications subject to change without notice.

# Light curtains, Light grids, Light beams and Scanner

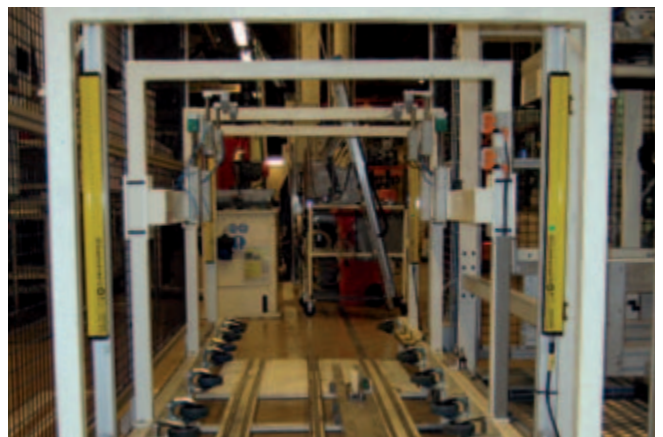
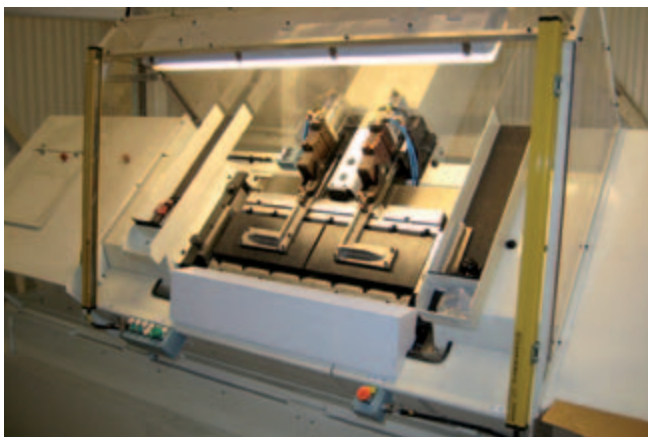

<b>Contents</b>	<b>Page</b>
<i>Why use light beams/light curtains?</i> _____	<b>7:2</b>
<i>Reset – 3 alternatives</i> _____	<b>7:4</b>
<i>Muting and blanking</i> _____	<b>7:5</b>
<i>Light curtain for short safety distance</i> _____	<b>7:6</b>
<i>Cycle initiation with light curtain</i> _____	<b>7:7</b>
<i>Safety distance</i> _____	<b>7:8</b>
<i>Focus II</i> _____	<b>7:10</b>
<i>Muting (bypassing) - Focus II</i> _____	<b>7:15</b>
<i>Muting sensors – Mute R</i> _____	<b>7:19</b>
<i>Muting sensors – Mute D</i> _____	<b>7:20</b>
<i>Bjorn</i> _____	<b>7:22</b>
<i>Focus Wet</i> _____	<b>7:24</b>
<i>Blanking programming – BP 1</i> _____	<b>7:25</b>
<i>Laser aligner JSRL-3</i> _____	<b>7:26</b>
<i>Connection examples Focus II</i> _____	<b>7:27</b>
<i>Safety Light Beam Spot</i> _____	<b>7:34</b>
<i>Laser scanner Look</i> _____	<b>7:38</b>

Descriptions and examples in this book show how the products work and can be used. This does not mean that they can meet the requirements for all types of machines and processes. The purchaser/user is responsible for ensuring that the product is installed and used in accordance with the applicable regulations and standards. We reserve the right to make changes in products and product sheets without previous notice. For the latest updates, refer to [www.abb.com/lowvoltage](http://www.abb.com/lowvoltage). 2011.

# Why use light grids and light curtains?

**Light beams and light curtains are a production friendly safety component that do not physically impact on the actions of the machine operator. Light barrier protection is also a good safety component for use when goods are to be passed in and out of a risk area.**

## How does a light beam/light curtain work?

Both light grids and light curtains utilise optical transmitter and receiver units. From the transmitters beams of infrared light are sent to the receiver. When a light beam is interrupted a dual stop signal is given to the dangerous machines inside the light beam/curtain protected area.

## What is the difference between a light curtain and a light beam?

A light curtain has several beams that are placed closely together whereas a light grid consists of only one, two, three or four light beams. The beams are closest on a light curtain that is used for finger detection. Then the resolution is 14 mm. Light curtain beams are at their widest spacing when used for thigh detection (90mm resolution). For light grids the beams are normally placed at a relative distance of 300 to 500 mm. The choice between light grid or light curtain is often a question of available safety distance, reach and price. Light curtains are often chosen for short safety distances. Light grids are chosen for long distances, up to 50 m, and for a low price.

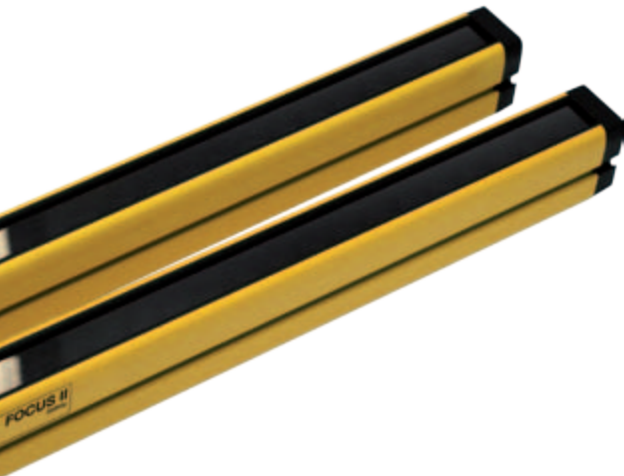
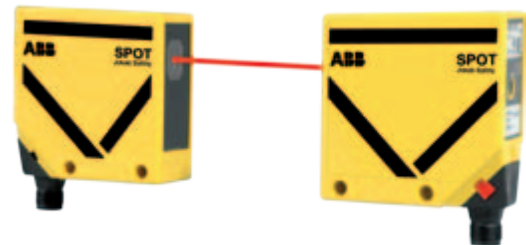

### Light grids for long distances

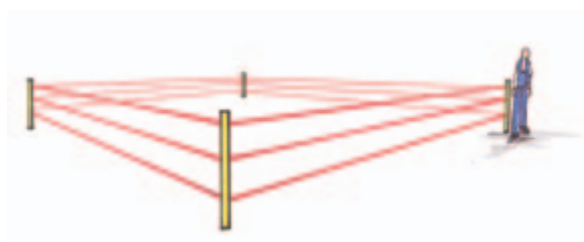

### Light grids with monitored bypassing during material transport



### Light curtain for short safety distances

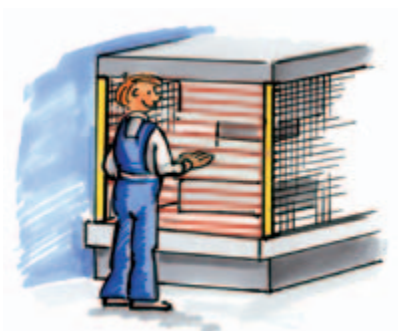

### Light curtain to protect during cycle initiation



### Light curtain as area protection



### Light curtain for inner area limiting



## What safety requirements are there for a light protection device?

High safety demands are stated in the standard EN 61 496-1 which deals with light protection. The main demands are on a safe stopping function and that light from light sources other than the transmitter or other disturbances do not affect the safety function.

Depending on how the safety function is built up there are safety components of type 2 and 4 to choose between. Type 2 and 4 relates in principle category 2/PL c and category 4/PL e according to EN ISO 13849-1

Type 4 which has the highest safety level, states that a fault is not allowed to affect the safety function and that the fault shall be detected by the outputs falling immediately or that they do not re-connect after being disconnected. Maximum allowed scattering angle for the light is  $\pm 2^\circ$ .

Type 2 states that a simple but monitored safety function is required, which means that the safety function shall be monitored through periodic tests which break the output when a fault occurs. Between the testing times there can though be faults which result in the safety component malfunctioning. The test function can either be built into the safety device or an external unit (e.g. the machine's control system) can initiate a test. Maximum allowed scattering angle for the light is  $\pm 4^\circ$ .

Light beams and light curtains are included among the products in the machine directive's appendix 4, which means that an external certifying procedure with an officially recognised institution is called for.

# Reset – 3 alternatives

## Supervised manual reset

When a light beam/light curtain is interrupted it will give a stop signal to dangerous machines within the risk area it protects and a reset-lamp will be lit. For a new start of the machine the light beam/light curtain has to be reset. This is done with the reset button which is placed where it cannot be reached from within the area which is protected. There are high requirements on the reset function - neither a short circuit nor a component fault shall give automatic reset. When the reset button has been set the outputs are activated and the reset-lamp is turned off.

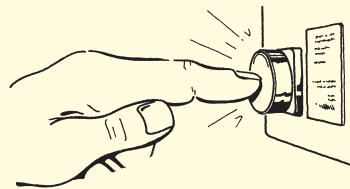

*Reset button with light indication.*

## Supervised time-reset

During time-reset unintentional reset is prevented when someone is inside the risk area. To reset the light beam (see figure) button 1 must first be pressed and afterwards button 2 within e.g. 5 seconds. This is especially important when one cannot see the entire area that is protected by the light beam.

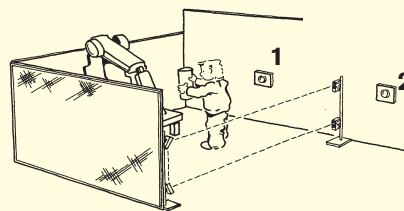

*Button 1 is pressed and afterwards, within a chosen time e.g. 5 seconds, button 2 is pressed for resetting the light beam.*

## Automatic reset

Automatic reset is used when the light beam is used for area monitoring. When the light beam is actuated this indicates that e.g. a robot is in the area. The robot is stopped if a person enters the same area e.g. through a gate. When the light beam is free again the control unit will be reset automatically.

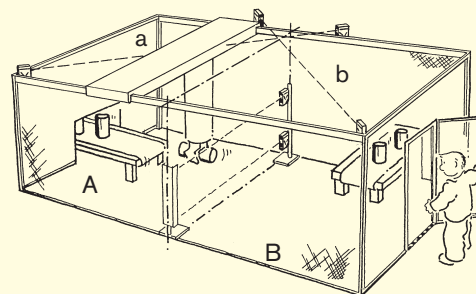

*A light beam b indicates that the robot is situated in area A. In this position it is possible to walk in through the gate to area B without stopping the robot.*



# Muting (bypassing)

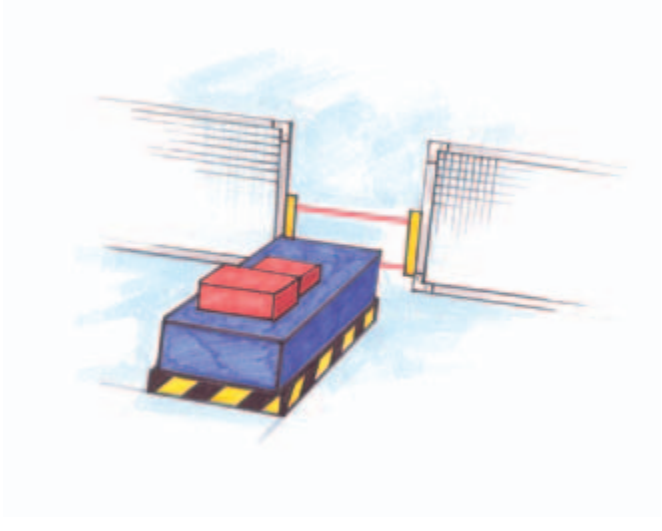

*Automatic bypassing of light beam when an auto industrial truck passes.*

Bypassing may be needed for different reasons. One of the most common reasons for bypassing is during in and out feeding of material on a conveyor, auto industrial trucks, etc. Another common application is bypassing while passing with a three-position device to the risk area.

Important aspects for bypassing are that it should be safe, not be activated by mistake and be difficult to defeat. In other words it should give a reliable bypassing when a loading carrier comes but not allow a human to pass. To achieve the highest safety level a dual and supervised bypassing system is needed (usually with at least two independent signals). If this is done with sensors, it is recommended they be of different kinds, because of the probability of them both malfunctioning for the same reason e.g. common mode failure. An example of a solution is to use a mechanical limit switch and a photo-cell sensor.

To avoid deliberate defeating/ manipulation of the bypassing sensors/signals a safety relay or a safety-PLC is connected thereby monitoring that the sensors are both activated and deactivated in every bypassing cycle.

The number of variations in bypassing systems are almost infinite. This depending on the specific requirements of each plant/machine. For Focus there are a number of bypassing possibilities prepared.

---

## Blanking (fixed or floating)

Blanking, (fixed or floating,) means permanent switching off of a number of beams in the protected field of a light curtain. This is a function that is permitted and used when an object that is larger than the resolution of the light curtain is permanently located in the protected area, without breaking the safety outputs (OSSD). If the object is removed from the protected area, the safety outputs are broken.

"Fixed blanking" means that the area that is intentionally switched off does not change while the machinery is operating. Other protected areas remain unaffected, with unchanged resolution.

"Floating blanking" means that the area that is intentionally

switched off can be changed and follow the location of the object that is being moved around in the protected area while the machinery is operating. Other beams are active and providing normal protection, but often with reduced resolution.

When a "blanking" function is used, it is very important that the light curtain provides protection and can detect objects as small as a finger or hand, depending on the resolution, anywhere outside the area that is rendered inactive because the object is there.

It must not be possible to select the "blanking function" without using a key, tool or similar unlocking device.

# Light curtain for short safety distance

A light curtain can be used in a machine or a production plant in the same way as a hatch. There is a great difference though when it comes to the risk situation. When one has a light curtain installed with a short safety distance in front of a dangerous machine, there is a high risk for spontaneous engagement into the machine, often called after-grasp. If the dangerous machine movement does not stop during such an engagement, one has a small chance of avoiding injury because one can reach the risk place within maybe 50 ms.

Therefore it is of great importance that the whole chain in the stopping circuit is fully dualled and supervised. Even valves and contactors which ultimately control dangerous movements normally have to be doubled up and supervised.

Regulations concerning safety distances are given in specific C-standards such as EN 692 for mechanical presses. If no specific C-standard is available, EN ISO 13855 is used.

## Automatic machines

For light curtains on automatic machines there shall be a reset function which is active when the machine is set for automatic production whether or not it is a passable protection. After an engagement one must first use a reset function then the restart of the cycle should be made with a separate starting device. The same reset applies for machines with semi-automatic drive.

## Operator protection during manually serviced machines

With manually operated machines where one or more operators pick in and out parts between every cycle. This type of application is the most risky because the number of engagements into the machine's dangerous area is often several times per minute.

## Light curtains on presses

Light curtains have traditionally been a common protection method among press applications and there has since long existed detailed information on the usage of light curtains on presses. (see next spread for presses)

## Safety level

Only light curtains of type 4 are accepted on presses.

## Reset

On the servicing side i.e. the side or sides where there is an operator that picks in and out parts, there shall be a separate reset function for the light curtain, usually a button. If there are several light curtains e.g. on the front and back there shall be one for each. If the light curtain is actuated during a dangerous movement the press should not be able to restart

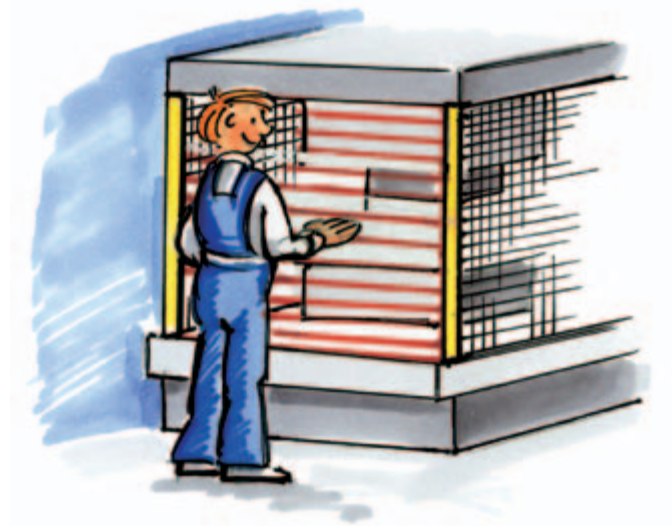

*Hand resolution*

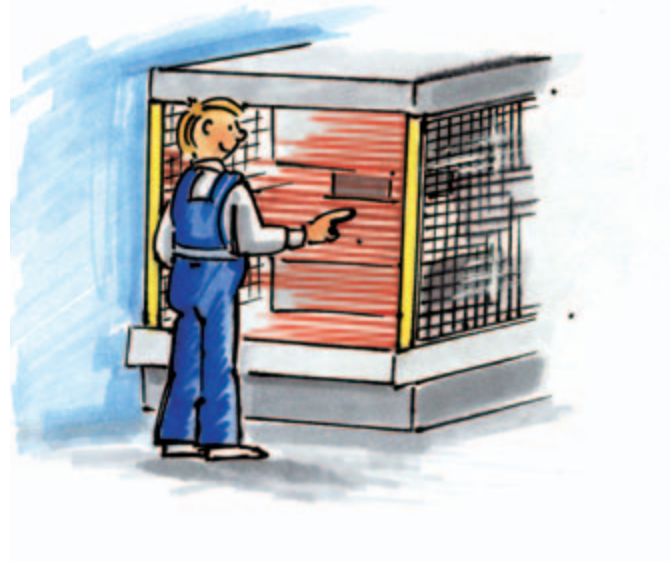

*Finger resolution*

without being reset. During engagement after the end of the cycle no reset is needed.

For a light curtain which is placed as protection on those sides which are not servicing sides, there shall be a reset button which always needs to be activated after an engagement.

# Cycle initiation with light curtain

## Cycle initiation

Cycle initiation is a concept when the machine is designed so that a new cycle starts when you take your hand out from the light curtain. A cycle is defined as the hand being placed in and taken out once. Usually it is possible to choose between one-cycle and two-cycle operation. During one-cycle a new press stroke is started when the light curtain has been actuated once and during two-cycle when the light curtain has been actuated twice. The operator thereby operates the press by the action of putting parts in and out.

Because the press starts without any particular command there are some risks involved and therefore many conditions have to be met before the machine operates.

To restrict the usage to smaller presses which cannot be entered there are the following limitations: The table height may not be lower than 750 mm, the stroking length may not be larger than 600 mm and the table depth may not be larger than 1000 mm. The light curtain shall have 30 mm or higher resolution. If the press is not started within approx. 30 seconds after the the end of the cycle, a new cycle should not be accepted without the light beam being again manually reset. **Note.** For machines with cycle initiation, the installation of the light curtain must be in accordance with machine parameters and all relevant standards and regulations.

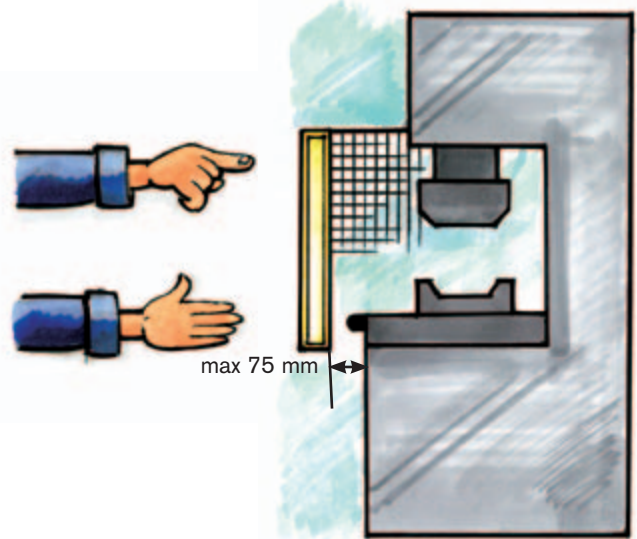

## Installation of light curtain

The light curtain must be installed so no-one can reach a trapping/crushing risk without actuating the light curtain. The most important thing is that there are no gaps under, on the sides and over the top during cycle operation. The lower edge of the light curtain must therefore be slightly below the press table edge. Also if it is open above the light curtain the height must be adapted so that it is not possible to reach over the protection area (see ISO 13855). Possible physical adjustment possibilities must be limited so that no gaps can occur.

Between the light curtains protection area and mechanical parts there shall only be max 75 mm gap to prevent a human from standing there. In practise to acheive this demand and the required safety distance one usually has to complement with e.g. additional mechanical protection or additional horizontally positioned light curtains i.e. step-in light curtain. Another solution could be a lying or an angled light curtain.

## Installation – correct and incorrect during cycle initiation



**Correctly installed.**  
The operator cannot reach into the machine without actuating the light curtain.



**Incorrect intallation.**  
Gap below the light curtain. The operator can reach into the machine without actuating the light curtain.



**Incorrect installation.** Gap above the light curtain. The operator can reach into the machine without actuating the light curtain.



**Correctly installed.**  
Light curtain complemented with a horizontal light curtain to detect the operator.



## Safety distance - light curtain according to EN ISO 13855

The safety distance 'S' is a minimum distance between a light curtain and a dangerous area. The safety distance shall guarantee that a person is not able to reach a dangerous machine part before the machine movement has stopped. This is calculated with the formula from EN ISO 13855 - Placement of safety devices with concern to the speed in which the body approaches the risk area.

$$S = (K \times T) + C$$

S = safety distance in mm

K = body/part of body (e.g. hand) speed in mm/s

T = T1 + T2

where

T1 = the safety device's reaction time in seconds

T2 = the machine's reaction time in seconds

C = further distance in mm based upon the body's intrusion towards the risk area before the safety device has been actuated.



Resolution for finger  
(≤ 14 mm) gives C = 0

\* If it is possible to reach the hazard zone by reaching over the light beam, an addition is made to the formula. In table 1 in EN ISO 13855 an alternative safety distance addition (Cro) is given to the formula  $S = (K \times T) + C$ . The greatest value out of C and Cro is to be used to prevent reaching the hazard zone by reaching over the light curtain/light beam.

## Calculation of safety distances for vertical and horizontal installation according to EN ISO 13855

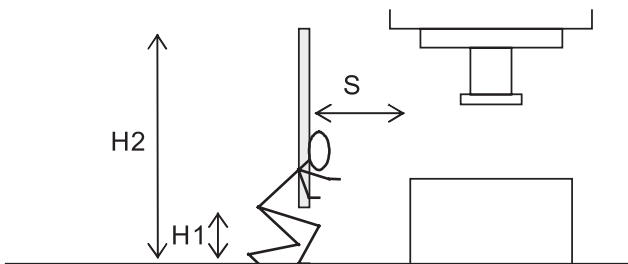

S = safety distance in mm

H1 = the lower beam may not be situated higher than 300 mm above the ground

H2 = the upper beam may not be situated lower than 900 mm above the ground

**The safety distance for vertical installation**  
**For  $S \leq 500$  mm the safety distance is calculated with the following formula:**

$$S = (2000 \times T) + 8 \times (d-14)$$

where d is the light curtain's resolution in mm.

K here is 2000 mm/s which represents the speed of the hand. The expression  $(8 \times (d-14))$  may never be less than 0. Minimum safety distance S is 100 mm.

**If the safety distance according to the formula above gets larger than 500 mm one can instead use:**

$$S = (1600 \times T) + 8 \times (d-14)$$

K is 1600 mm/s which represents the speed of the body. Minimum safety distance according to this formula is 500 mm.

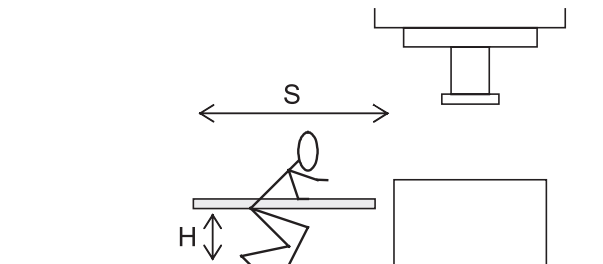

S = safety distance in mm

H = the light curtain field must be positioned between 0 and 1000 mm above the floor

**The safety distance for horizontal installation is calculated with the following formula:**

$$S = (1600 \times T) + (1200 - 0,4 \times H)$$

where H is the safety field's height above the reference plane, e.g. the ground

$(1200 - 0,4 \times H)$  may not be less than 850 mm. Depending on the resolution, d, that the light curtain has, there is a minimum height that the safety field may be placed. This is calculated with:

$$H = 15 \times (d - 50).$$

H cannot be less than 0. With a resolution  $d=14$  or  $35$  mm one can therefore install the light curtain from  $H = 0$  and up. The higher it is situated, the shorter the safety distance gets. The highest permissible height H of the safety field is 1000 mm.

When you use a horizontal light curtain as entry protection, the depth of the light curtain should be at least 750 mm to prevent people from inadvertently stepping over it. The estimated safety distance is measured from the machine's hazardous section to the outermost beam of the horizontal light curtain (seen from the machine).

## Safety distance for light beams according to EN ISO 13855

For light beams the safety distance is calculated from the following:

$$S = (1600 \times T) + 850 \text{ mm}$$

The formula applies whether one installs 2,3 or 4 beams. It is the risk assessment that decides the number of beams that are to be chosen. The following possibilities must be considered.

- to crawl under the lowest beam;
- to reach over the top beam;
- to reach in between two beams;
- that the body passes in between two beams.

To fulfill the requirements the beams should be installed at the following heights:

Number of beams	Height over the reference plane, e.g. ground
4	300, 600, 900, 1200
3	300, 700, 1100
2	400, 900

## Safety distances for new and old presses

### New presses

For new CE-marked presses there are specific requirements from the standards **EN 692** Machine tools – Safety – Mechanical presses – Safety and **EN 693** Machine tools – Safety – Hydraulic presses.

The same requirements apply for vertical installation on presses as with vertical installation on other machines with the difference that C is given according to the following:

Resolution, d, (mm)	Safety distance addition, C (mm)	Cycle initiation
≤ 14	0	Permitted
>14 - 20	80	
>20 - 30	130	
>30 - 40	240	Not permitted
>40	850	

### Other manually serviced machines

The rules for presses may well be applied to other machines which function in a similar way and that have the same risk situation. There is no other standard which is as detailed on the usage of light curtains.

For cycle initiation the light curtains resolution, d, must be ≤ 30 mm. This applies to both old and new (CE-marked) presses.

### Old presses

N.B. For old presses there are different rules for each country.

The formula that applies here is:

$$S = 2500 \times T + C$$

The safety distance addition C for different resolutions of the light curtain is given in the following table

Resolution, d, (mm)	Safety distance addition, C (mm)
<16	0
16	70
20	110
25	130
30	140
35	240
40	270
45	300
50	330
55	360
>55	850

# Safety Light Grids and Safety Light Curtains

## Focus II



### A light grid/light curtain with many possibilities

Focus II is a new version of our previous light beam/light curtain Focus. Features such as muting and override are standard in all Focus II light curtains and light beams. For light curtains, blanking and break functions are also standard. The optical sensors on Focus II also have variable frequency. The Focus II units are light grids/curtains with safety functions intended for applications where it is of great importance to protect persons from a dangerous machine, robot or other automated systems where it is possible to access to a dangerous area.

Focus II creates a protection field with infrared beams. If any beam is interrupted the safety mechanism is triggered and the dangerous machine is stopped. Focus II fulfills the requirements for non-contact safety equipment type 4 (Focus 4 series) according to the international regulation standard EN 61496-1.

Units are available with safety heights between 150 and 2400 mm. All electronic control and monitoring functions are included in the light curtain profiles. External connec-

tion is made via a M12 connection at the end of the profile. Synchronization between transmitter and receiver is achieved optically. No electrical connection between the units is required. Control and monitoring of the beam transmission is carried out by two micro-processors which also give information on the status and alignment of the light curtain via several LEDs.

### Muting and Override included in all Focus II

The "Muting" and "Override" functions are available on all Focus II light grids/curtains and is enabled directly when an indication lamp LMS is connected. Muting implies that one or more segments or the whole light curtain can be bypassed during in and out passage of material.

In the Focus II with Muting there is also an Override function which makes it possible to bypass the light grid/curtain i.e. activate the outputs if a machine start is necessary even if one or more light beams are interrupted. This is the case when the muting function is chosen and the A and B inputs

### Approvals:



### Application:

Optical protection in an opening or around a risk area

### Features:

- Type 4 according to EN 61496
- Flexible assembly
- LED indication
- High protection class (IP65)
- Range 3-40 m
- Time reset
- Fixed / floating blanking
- Muting
- Single/Double Break funktion
- External Device Monitoring (EDM)
- Available with different resolutions
- Up to PL e according to EN 954-1/EN ISO 13849-1



are activated. If for example during the muting operation a loading pallet has stopped inside the safety field after a voltage loss, the override function is used to enable the pallet to be driven clear.

### Floating blanking or fixed blanking

It is also possible to obtain the Focus II light grids/curtains with either "floating blanking or fixed blanking". Floating blanking makes it possible to 'disconnect' a defined number of beams from the safety field. The object is then free to move in the safety field without the safety function being triggered. During "fixed blanking" the object is not able to move in the safety field. The other beams are active with normal resolution.

### Safety outputs OSSD1 and OSSD2

Focus II has two PNP outputs - OSSD1 and OSSD2. If the load to be switched is alternating current or requires a higher current than 500 mA then one should use a safety relay e.g. RT9, Pluto PLC or the FRM-1 unit (converts the outputs to relay contacts) from ABB Jokab Safety. The FMC-Tina and Tina 10A/10B converts the outputs to a dynamic signal for connection to Pluto or Vital. Pluto can also work directly with the OSSD-outputs.

### Single/Double Break function

This function is used for presses when the operator prepares or picks out a detail. With the Single Break function the light curtain allows operation after entry and withdrawal

out of the curtain. Similarly, the Double Break function allows operation after entry and withdrawal twice.

### External Device Monitoring (EDM)

In all light beams and light curtains an EDM function is available which allows Focus II to test if the external control element responds correctly. A test channel is connected through the respective contactor, in order to detect any faults and thereby prevent a reset.

### Reset

On every Focus II there are inputs for reset and other functions:

Reset, Alignment and Override (bypassing is only possible when muting is used.) The reset option is chosen through dual switches in the Focus II receiver. At delivery, Focus II is set to automatic reset.

- **Automatic reset** – When the light field is free the outputs are closed directly. (Setting when delivered).
- **Manual reset** – Focus II gives a ready signal when the light field is free and the reset button has been actuated.
- **Time reset** – During manual reset. To reset the Focus II a pre-reset button must first be actuated and afterwards within 8 seconds a reset button outside the risk area must be actuated.

## Focus II light curtain

### Standard:

- Muting (bypassing) partly or completely
- Supervised output for muting lamp
- Override
- Manually supervised or automatic reset
- Time-reset
- Fixed or floating blanking
- Single/Double Break
- EDM

### Option:

- CUT – a light curtain cascaded with another light curtain. The two light curtains can have different resolutions.



## Focus II ljusbom

### Standard:

- Muting (bypassing) of one, two, three or four beams
- Supervised output for muting lamp
- Override
- Manually supervised or automatic reset
- Time-reset.

### Option:

- Light grids for tough environments with parallel beams of light for improved reliability.

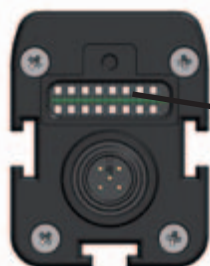

With the switches at the bottom of Focus II you can choose the function you desire.

## Summary - Focus II light curtain/grid, Type 4 (FII-4)

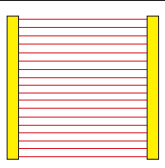
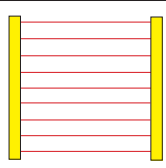
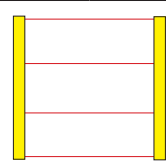
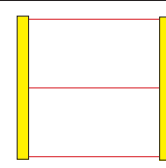
				
Type 4	FII-4-14-zzzz	FII-4-30-zzzz	FII-4-K4-zzzz	FII-4-K3-800
Resolution	14	30	300   400	400
Height (mm=zzzz)	150 300 450 600 750 900 1050 1200 1350 1500 1650 1800 1950 2100 2250 2400	150 300 450 600 750 900 1050 1200 1350 1500 1650 1800 1950 2100 2250 2400	900   1200	800
Range (m) SR LR	0,2-3 3-6	0,2-7 7-14	0,5-20 20-40	0,5-20 20-40
Reaction time off (ms)	12-68	9-31	13	13
Reaction time on (ms)	138-104	141-119	142	142
Manual reset	•	•	•	•
Automatic reset	•	•	•	•
Pre reset	•	•	•	•
Muting inputs	•	•	•	•
Muting lamp supervision	•	•	•	•
Override	•	•	•	•
Muting T/L/X	• / • / •	• / • / •	• / • / •	• / • / •
Blanking 3 types	• / • / •	• / • / •	- / - / -	- / - / -
Single/Double break	• / •	• / •	- / -	- / -
EDM	•	•	•	•
Dyn. Adaption to Vital/Pluto	☒	☒	☒	☒

• Standard      ☒ With Tina 10A/10B/10C or FMC-Tina

Note!

For ordering data and article number see the product list. For more information see the manual on our home page.

1  
2  
3  
4  
5  
6  
7  
8  
9  
10  
11  
12  
13  
14

FII-4-K2-500	FII-4-K4-zzzz D	FII-4-K3-800 D	FII-4-K2-500 D	FII-4-K2C-zzzz	FII-4-K2C-800	FII-4-K1C-500		
500	300	400	400	500	300	400	800	500
500	900	1200	800	500	900	1200	800	500
0,5-20 20-40	0,5-20 20-40	0,5-20 20-40	0,5-20 20-40	0,5-7	0,5-8	0,5-12		
13	13	13	13	13	13	13		
142	142	142	142	142	142	142		
•	•	•	•	•	•	•		
•	•	•	•	•	•	•		
•	•	•	•	•	•	•		
•	•	•	•	•	•	•		
•	•	•	•	•	•	•		
•	•	•	•	•	•	•		
• / • / •	• / • / •	• / • / •	• / • / •	• / • / •	• / • / •	• / • / •		
- / - / -	- / - / -	- / - / -	- / - / -	- / - / -	- / - / -	- / - / -		
- / -	- / -	- / -	- / -	- / -	- / -	- / -		
•	•	•	•	•	•	•		
□	□	□	□	□	□	□		

## Accessories

### Muting-unit for Focus

#### Standard:

Muting (bypassing) of light curtain or light grid in one or two directions(L-form, T-form). The unit is connected directly to the light curtain/grid via a M12-connection.



### FMC-Focus Muting Connector med M12-kontakt

#### Standard:

FMC is a small, optimised connection block with M12 inputs. FMC is used for M12-connection of muting sensors, muting lamp, pre-reset (for time reset), reset button with indication, override and safety outputs.



Technical data – Focus II	
<b>Manufacturer:</b>	ABB AB/Jokab Safety, Sweden
<b>Supply voltage:</b>	24VDC ±20%
<b>Power consumption:</b>	
Transmitter	70 mA maximum
Receiver	100 mA maximum
<b>Safety level</b>	
EN/IEC 61496	Type 4
EN 954-1	Focus II type 4: Category 4
EN ISO 13849-1	Focus II type 4: PL e
EN/IEC 61508	Up to SIL 3
<b>PFH<sub>d</sub></b>	2,5x10 <sup>-9</sup>
<b>Resolution:</b>	14 mm and 30 mm
<b>Wavelength on transmitter LED:</b>	880 nm
<b>Profile dimensions:</b>	37 x 48 mm
<b>Protection class:</b>	IP65
<b>Operating temperature:</b>	-10 to +55° C
<b>Storage temperature:</b>	-25 to +70° C
<b>Outputs:</b>	2 supervised PNP outputs with cross circuit monitoring
<b>Max. load:</b>	500 mA (overload c.c. protection)
<b>Response time:</b>	9 – 68 ms (depending on model)
<b>Connection transmitter:</b>	M12 5-pin
<b>Connection receiver:</b>	M12 8-pin
<b>Indikering:</b>	Lysdioder på sändare och mottagare som indikerar injustering, smuts, matningsspänning och utgångar
<b>Enclosure:</b>	Aluminium painted yellow
<b>Conformity:</b>	2006/42/EG, EN/IEC 61496-1/2, EN 954-1, EN ISO 13849-1, EN/IEC 61508

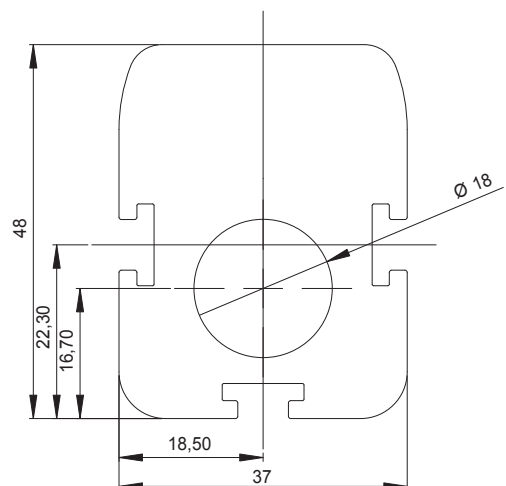

# Muting (bypassing)

## - Focus II

Built-in muting for Focus is available in three ways:

- Pre-made muting units MFII-T and MFII-L, which have integral photo-cells. Units are manufactured with the same profile as Focus.
- Connection of muting sensors via a FMC.
- Separate connection of muting sensors (Mute R or Mute D) directly to the Focus receiver unit.

### Muting-lamp

In the Focus receiver unit it is also possible to directly connect a muting-lamp. It is also possible to connect the muting-lamp via a FMC. During bypassing the muting-lamp is lit. Bypassing is only possible if the muting-lamp is functioning.

### Conditions for muting

- Muting input A must be actuated at least 30ms before muting input B for muting to be possible.
- Muting is activated as long as the conditions are fulfilled. See also requirements for muting in IEC/TS 62046 chapters 4.7.3 and 5.5.

### Muting with MFII-T and MFII-L units

MFII-T and MFII-L are muting units with integrated photo cells in the same profile type as the Focus light grid/curtain. No additional sensors are required because the muting units contain the required components. MFII-T/MFII-L is connected directly to Focus with M12-connectors.

Alt.1

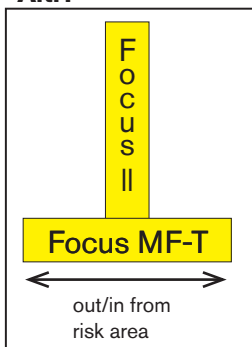

Alt.2

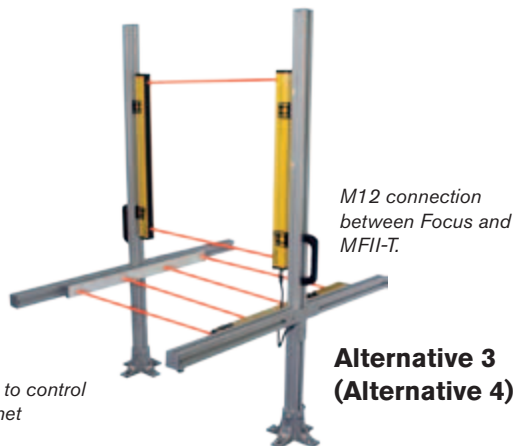
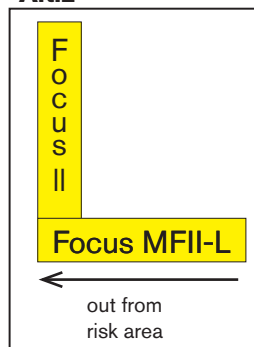

### MFII-T (Diagram 1)

MFII-T contains four photo cells A1, B1, B2 and A2 arranged as shown. They are configured for installations where material is transported "in" or "out" or in both directions "in and out".

**NOTE.** All standard Focus light grids/curtains are delivered connected to function together with the MFII-T.

### MFII-L (Diagram 2)

MFII-L contains two photo cells A1 and B1 which are actuated before exiting through the light grid/curtain. The light grid/curtain being bypassed just prior to the exit of the material.

**NOTE.** Unit MFII-L is primarily intended for material transport "out" of a working area. The standard Focus light grid/curtain delivered does not function together with the MFII-L version. They need to be ordered separately together with the MFII-L unit.

### MFII-T Reflex (Alternative 3)

Contains four transmitters/receivers and a separate reflector unit. Range 6m. Used in the muting mode for transport of material into and/or out of hazardous areas. For other functions refer to Alternative 1. This unit, together with light beam F4-K1C-500 provides electrical connections on only one side!

### MFII-L Reflex (Alternative 4)

Contains two transmitters/receivers and a separate reflector unit. Range 6m. Used in the muting mode for transport of material into and/or out of hazardous areas. For other functions refer to Alternative 2. This unit, together with light beam F4-K1C-500 provides electrical connections on only one side!

## Examples on how the muting sensors MFII-T and MFII-L can be placed

### A solution with Focus Muting unit MFII-T with integrated muting sensors.

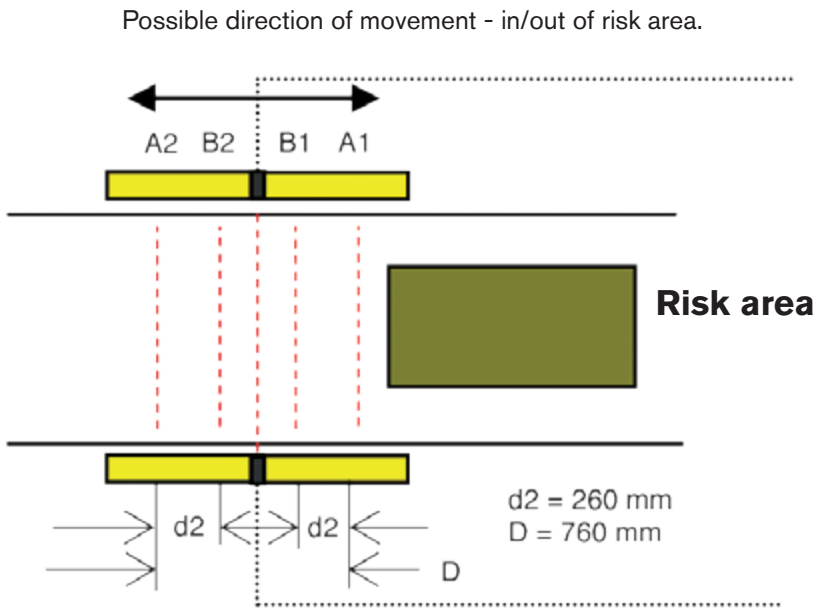

### A solution with Focus Muting unit MFII-L with integrated muting sensors

This solution shall only be used for movement out from a risk area.

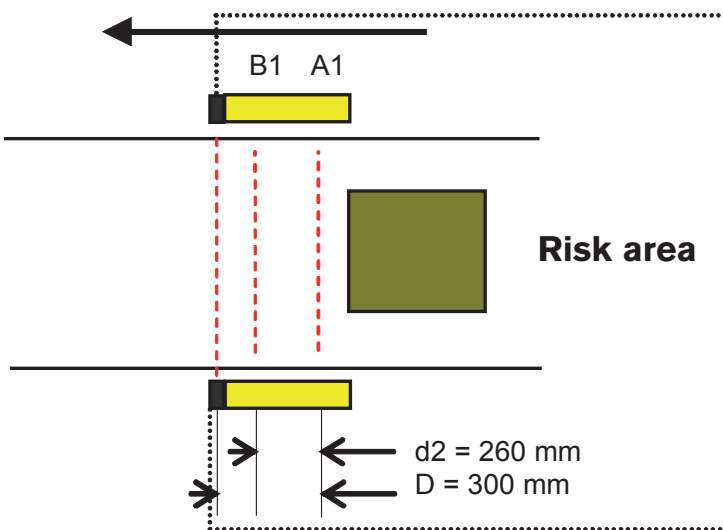

**NOTE.** the muting sensors A and B must be placed so that the sensor A is always activated at least 30 ms before sensor B.

D: indicates the minimum length of the material that is to actuate the muting sensors that must be maintained during the passage through the light grid/curtain.  
d2: indicates the measurement between the two/four pre-assembled muting sensors within the MFII-L and MFII-T.



## Muting with FMC and FMI units



The **FMC Focus Muting Connector**, is a small, optimal unit which is used when the Focus light grid/curtain is required to be bypassed for in and out passage to and from a dangerous area. The FMC-unit is easily connected to Focus with a M12 connector.

The **FMI Focus Muting Indicator**, is a small unit with built-in muting lamp, reset button, "power off" (for alignment and override). The FMI unit is connected to the FMC unit with M12 connectors to facilitate the muting function connection.

## Various FMC, FMI, FRM- versions and Tina units

The Tina-versions have dynamic safety outputs for Vital/Pluto.

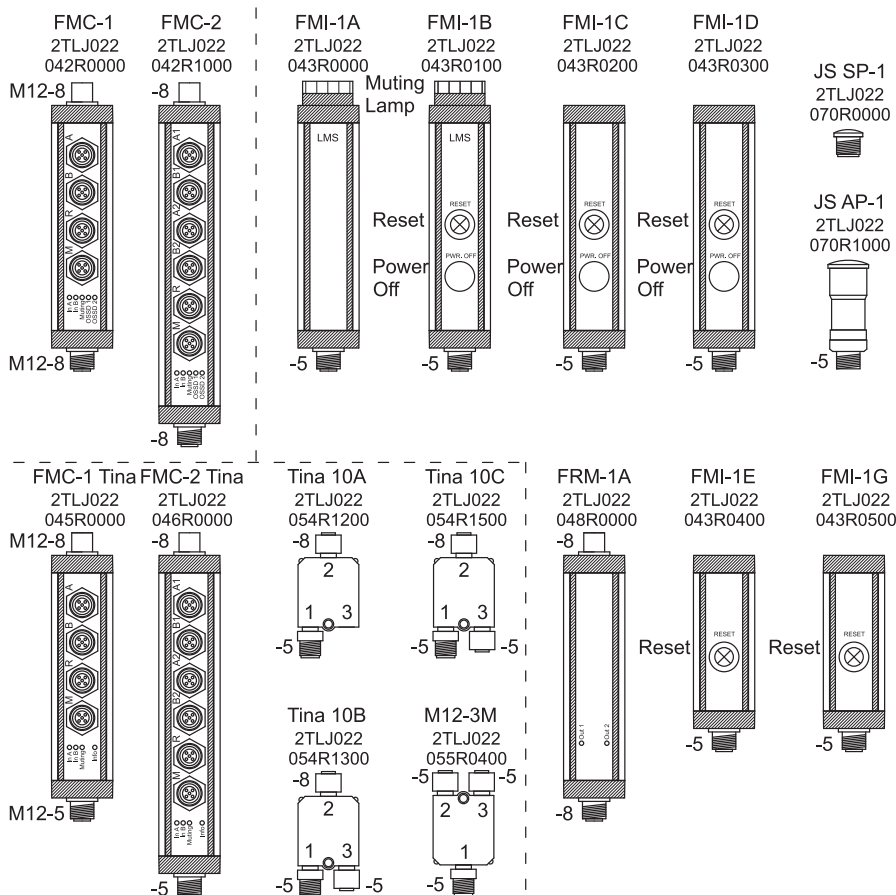

- FMC-1(2):** with connectors for muting sensors (A+B), reset, power off and muting lamp (R) and muting lamp (M).
- FMI-1A:** with muting lamp only.
- FMI-1B:** with reset, power off and muting lamp.
- FMI-1C:** with reset and power off.
- FMI-1D:** with reset, power off and internal resistor for the muting lamp.
- FMI-1E:** as pre reset connected to connector A (A2) on FMC-1(2) (Tina).
- FMI-1G:** with reset, and internal resistor for the muting lamp.
- FMC-1 (2)Tina:** same as FMC-1(2) but connected to Vital or Pluto.
- Tina 10A:** adaptor unit for connecting Focus to Vital or Pluto.
- Tina 10B:** simplified FMC-1(2) Tina including only the connector (R).
- Tina 10C:** simplified FMC-1(2) Tina including only power supply on con.no.3.
- M12-3M** bypass unit for easy connection outside the cabinet
- FRM-1A:** translates the two OSSD outputs to relay outputs (and power supply).
- JS SP-1:** protection plug for not used connectors.
- JS AP-1:** adaptor for FMC units to use instead of FMI-1B or -1D on the (R) connector including muting resistor.

## Connection of Focus and muting components with FMC-1 and FMI-1

**Ex 1.** Connection of light curtain with connection block FMC-1, test/reset button and switch for supply voltage placed in (by) the control cabinet.

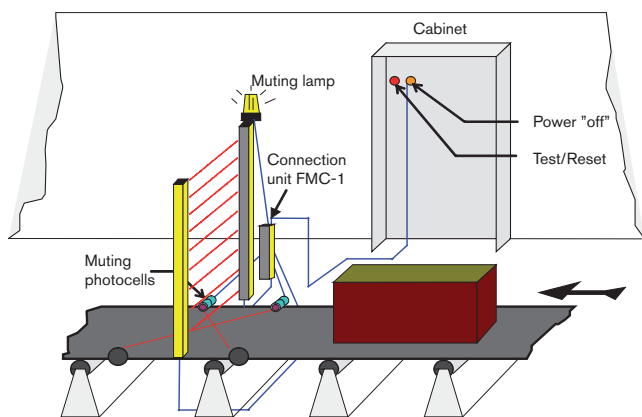

**Ex 2.** Connection of light curtain with connection block FMC-1. The Reset unit FMI must be placed out of reach from the risk area.

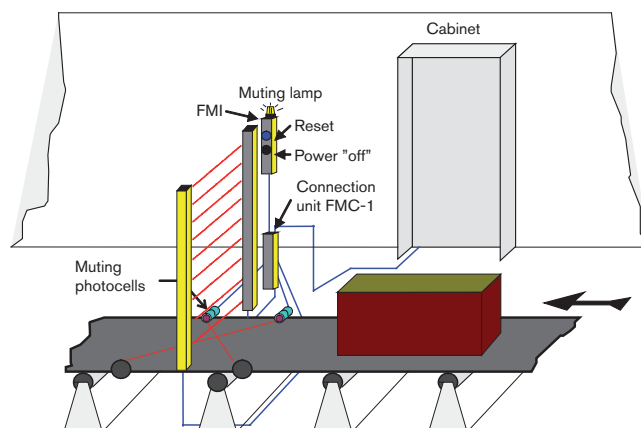

## Connection of Focus and muting components directly to the control cabinet

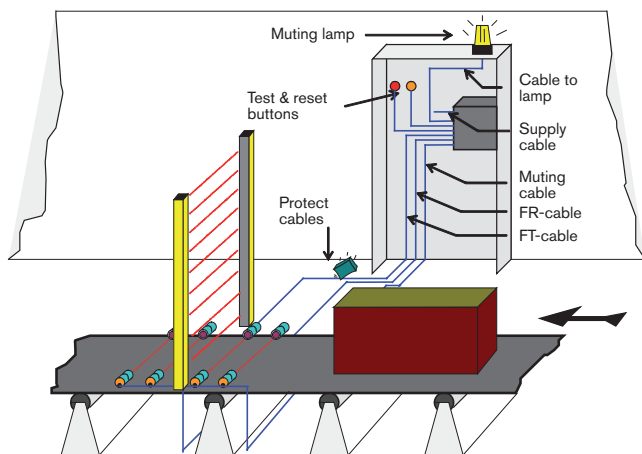

- The TEST /RESET button shall be placed so the operator can see the protected area during reset, testing, and bypassing. It should not be possible to reach the button from within the risk area.
- The LMS lamp for indication of muting and bypassing shall be placed so that it can be seen from all directions from where it is possible to access the dangerous area
- If photo cells are used as muting sensors then the sensor receivers should be assembled on the light curtain's transmitter side to minimise the interference risk.
- The system is protected against dangerous functions caused by damage on the transmitter cable and/or the receiver cable. However, we recommend that the cables be protected so that physical damage to them can be minimised.

## M12-connection device with screw connectors

Female - Connector-view from cable side

M12-C03

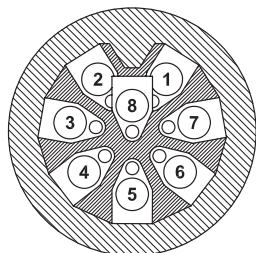

M12-C01

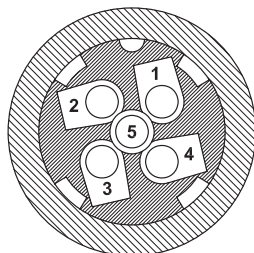

Male - Connector-view from cable side

M12-C04

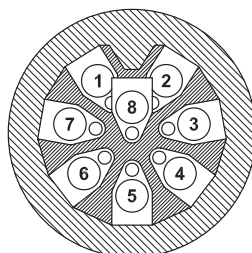

M12-C02

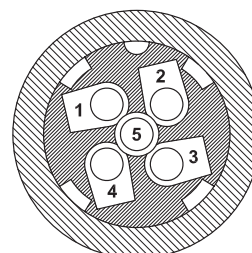

# Muting sensors – Mute R

## Retro-reflective with polarizing filters



10...30 VDC  
PNP  
Dark-on output

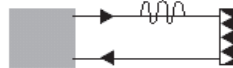

### Features:

- Range adjustable
- Light reserve warning indicator
- Transistor output, PNP
- 1000 Hz switching frequency
- Short-circuit protection, reverse polarity protection and power-up output suppression
- Connector M12
- EMC tested according to IEC 801 and EN50081-1/ EN 50082-2

Technical data	
Manufacturer	ABB AB/Jokab Safety, Sweden
Article number/ordering data: Mute R (FSTR-1)	2TLA022044R0000
Output	PNP, dark on
Connection	Connector M12
Range adjustment	Yes
Range	0.15... 2.5 m (with reflector FZR 1) 0.15...5m (with reflector FZR 2A)
Light source	Visible-red, 660 nm, pulsed with polarizing filter

Supply voltage	10...30 VDC
Allowable ripple	$\pm 10\%$ of $U_s$
Current consumption (without load)	< 15 mA
Max. load current	100 mA
Residual voltage	< 1,6 V
Max. switching frequency	1000 Hz
Protection class	IP67
Temperature (operating and storage)	-25 to +65° C
Weight	approx. 15 g

*All technical data at 25° C and 24V.*

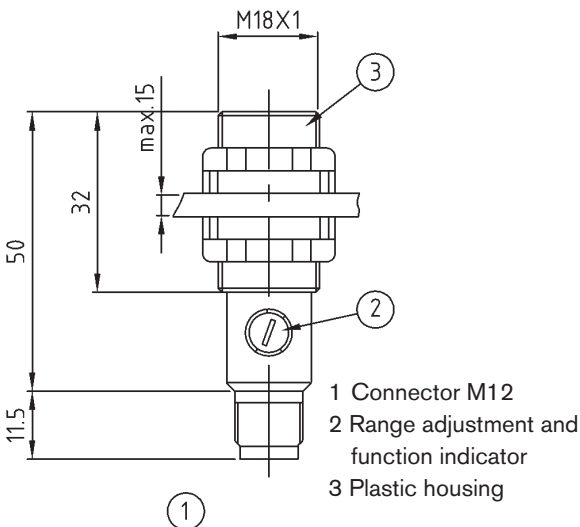

### PNP output

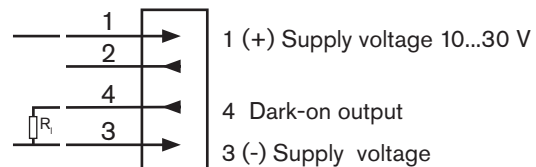

### Dark-on output

The output is activated when an object interrupts the light.

### Connector M12

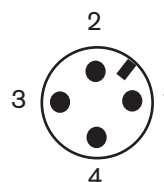

# Muting sensors – Mute D

## Diffuse-reflective with background rejection



light-on output  
dark-on output

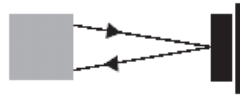

### Features:

- Electronically adjustable background rejection
- Light reserve warning indicator
- Dual transistor outputs, PNP
- Short-circuit protection, reverse polarity protection and power-up output suppression
- Connector M12 rotatable
- EMC tested according to IEC 801 and EN50081-1/EN 50082-2

Technical data	
Manufacturer	ABB AB/Jokab Safety, Sweden
Article number/ordering data: Mute D (JSOGP800)	2TLA022044R1000
Output	2 PNP (light- and dark-on)
Connection	Connector M12
Range adjustment	Yes
Range (depending on material)	0.2... 0.8 m
Light source	Infrared-LED, 880 nm, pulsed
Supply voltage	10...30 VDC

Allowable ripple	$\pm 10\%$ of $U_s$
Current consumption (without load)	<35 mA
Max. load current	200 mA
Residual voltage	<1,6 V
Max. switching frequency	200 Hz
Protection class	IP67
Operating temperature	25 to +65° C
Weight	approx. 130 g
<i>All technical data at 25° C and 24V.</i>	

- 1 Function indicator
- 2 Range adjustment
- 3 Glass covered optics
- 4 Center of the optical axis
- 5 Preferred detection direction
- 6 Bore for 5 mm self-tapping screw
- 7 Connector M12
- 8 Opening for M5 nut

### PNP output

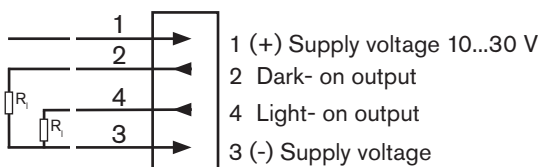

### Light-on output:

Output energized when object is present.

### Dark-on output:

Output energized when no object is present.

### Connector M12

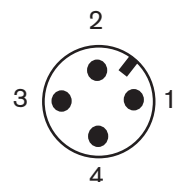

# Muting with Mute R and Mute D

**A solution with two sensors (here photocells) and one (or two) movement directions for material transport:**

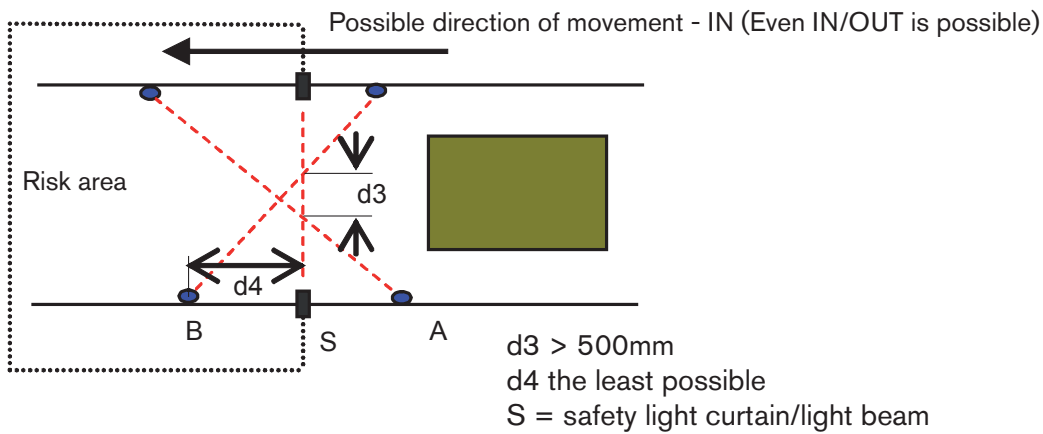

**A solution with four sensors and one movement direction for material transport:**

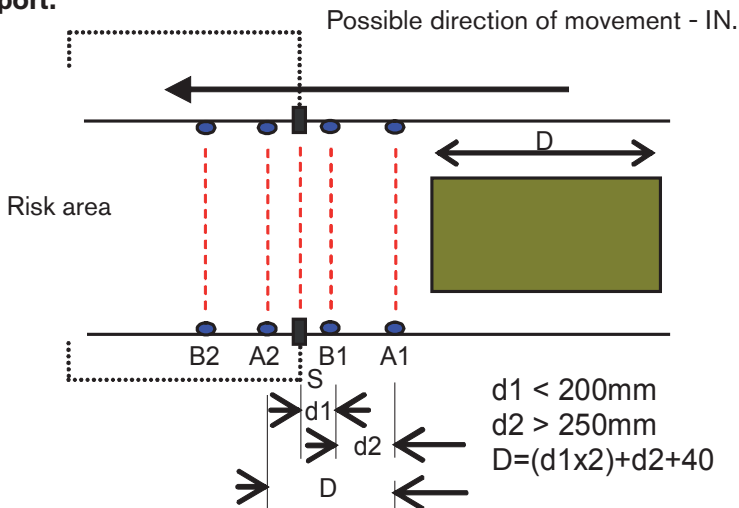

**A solution with four sensors and two movement directions for material transport:**

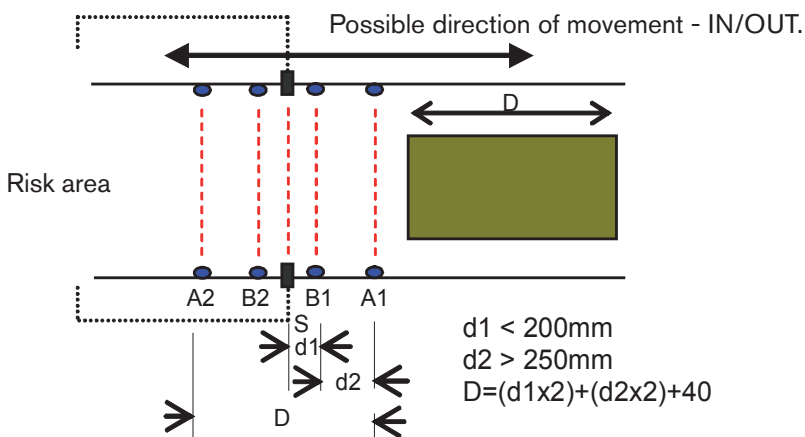

D: indicates the minimum length on the material that is to actuate the muting sensors that must be maintained during the passage through the light grid/curtain.

$d1$  must be as short as possible, and definitely less than 200 mm

$d2$ : indicates the distance between A1 and B1

# Bjorn

A strong support for light grids and mirrors

## Application:

Protects light curtain, light grids and mirror

## Features:

Robust  
Adjustable

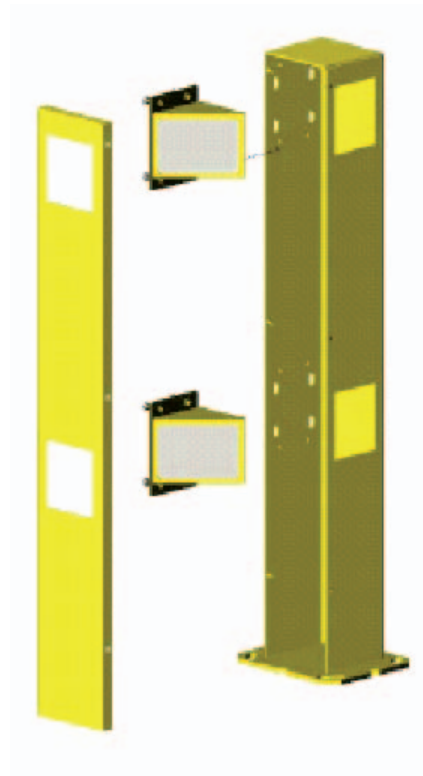

Bjorn is a very stable and flexible stand system in which Focus safety light beams and mirrors are mounted in the stand. The fixings for the mirrors in the stand can be turned to provide either vertical or horizontal angles. The robust material of the Bjorn protects Focus units from direct collisions, and thus prevents unnecessary material damage and halts in production.

Bjorn is available in stock as a standard version for dual safety light beams. Bjorn versions can also be ordered for Focus 3 and 4-beams.

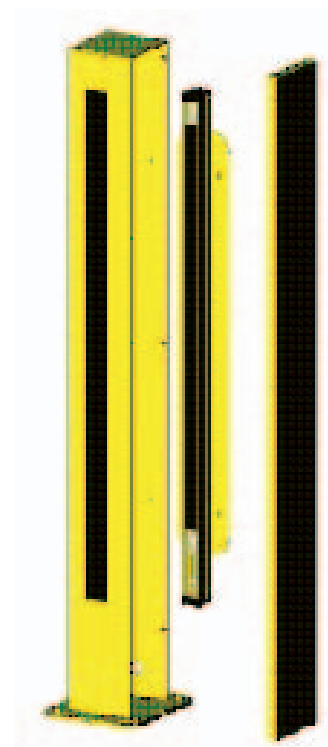
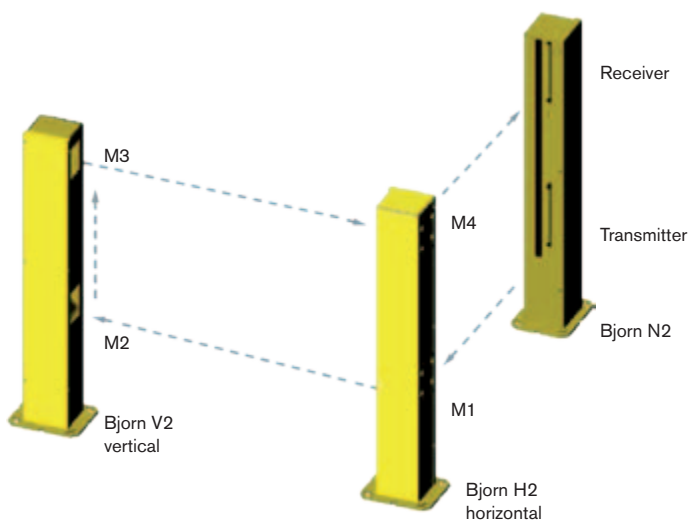



## Technical data – Bjorn

<b>Manufacturer:</b>	ABB AB/Jokab Safety, Sweden
<b>Article number/ ordering data:</b>	Bjorn H2 2TLA022041R4000 Bjorn V2 2TLA022041R4100 Bjorn H3 2TLA022041R4200 Bjorn H4-1 2TLA022041R4300 Bjorn H4-2 2TLA022041R4400 Bjorn N2 2TLA022041R4500 Bjorn N3 2TLA022041R4600 Bjorn N4-1 2TLA022041R4700 Bjorn N4-2 2TLA022041R4800 Bjorn N5 2TLA022041R4900
H = Horizontal reflection V = Vertical reflection N = Floor stand for Focus	
<b>Colour:</b>	Yellow powder-coated (RAL 1018)
<b>Material:</b>	3 mm steel
<b>Dimensions:</b>	Cross section 146 mm x 130 mm Foot 230 mm x 190 mm
<b>Weight:</b>	H2, V2 and N2 15 kg/piece H3 17 kg/piece H4-1, H4-2 20 kg/piece N5 27 kg/piece
<b>Mirror reduction:</b>	≤10 %

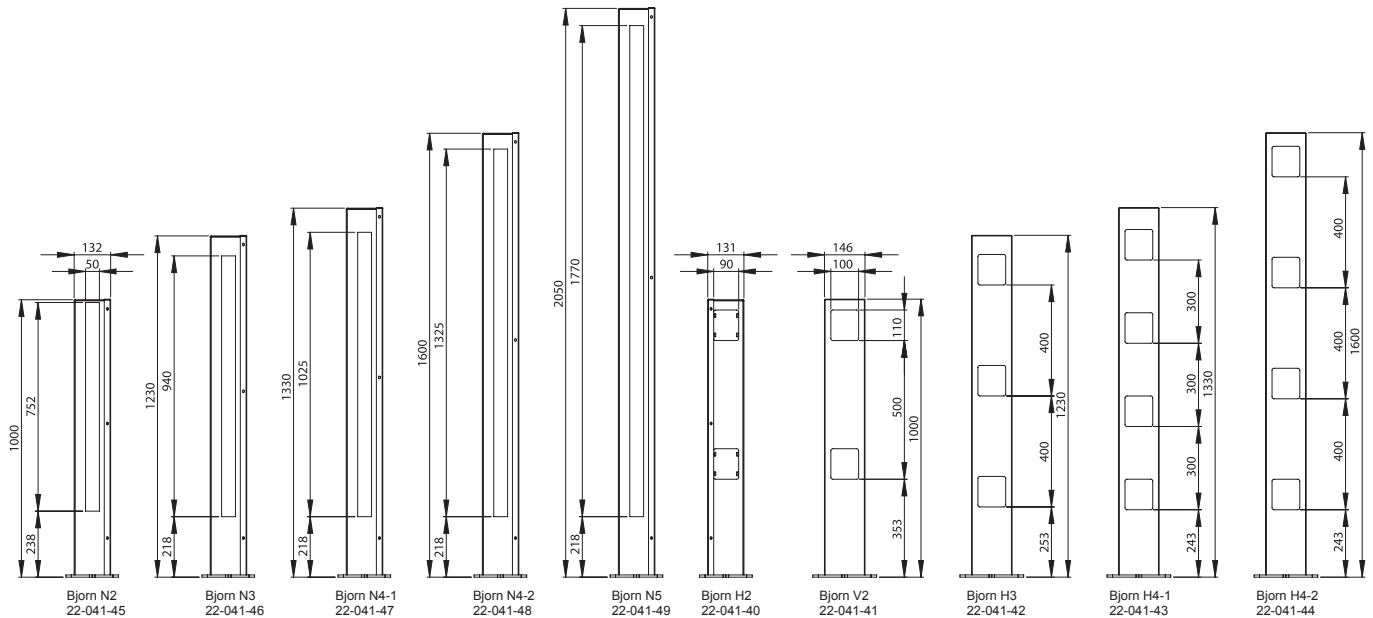
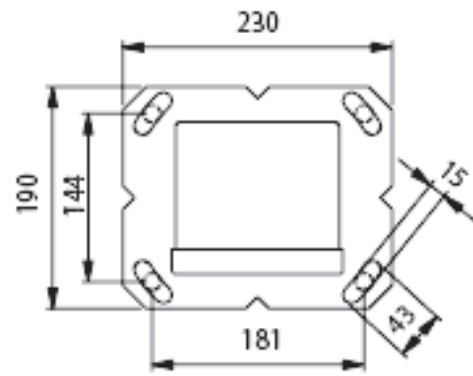

# Focus-Wet

– protection against water and dust for Focus light curtains and light beams



Wet is used for protection against water (or dust) where extreme washing conditions are encountered. The protective encapsulation rating (IP68) now enables Focus light curtains and light beams to be used for such applications as the food industry where the use of high pressure washing for cleaning machinery often occurs. The draining and through ventilation capabilities mean that condensation can be avoided.

Wet, with Focus light curtains or light beams, is pre-assembled complete with cabling, on request. During installation on a machine a Wet unit can be adjusted by  $\pm 20^\circ$  with the accompanying angle bracket. The plastic tube is rotatable and the outside is easy to clean.

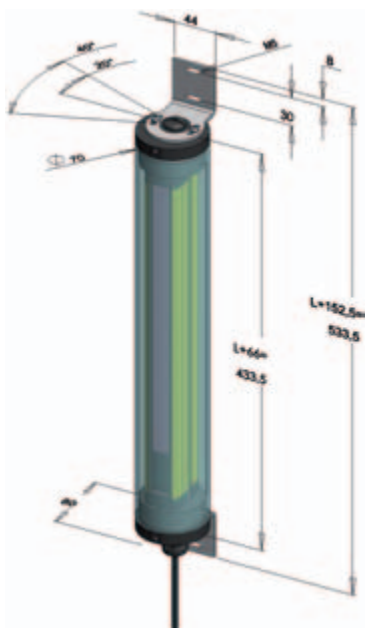

## Application:

Protection in severe environments

## Features:

Adjustable  $\pm 20^\circ$

Rotatable and replaceable tube

Capable of draining and through ventilation

Technical data – Wet	
<b>Manufacturer:</b>	ABB AB/Jokab Safety, Sweden
<b>Article number/ ordering data:</b>	
WET-150 FII	2TLA022038R4000
WET-300 FII	2TLA022038R4100
WET-450 FII	2TLA022038R4200
WET-600 FII	2TLA022038R4300
WET-750 FII	2TLA022038R4400
WET-900 FII	2TLA022038R4500
WET-1050 FII	2TLA022038R4600
WET-1200 FII	2TLA022038R4700
WET-1350 FII	2TLA022038R4800
WET-1500 FII	2TLA022038R4900
WET-1650 FII	2TLA022038R5000
WET-1800 FII	2TLA022038R5100
WET-K-500 FII	2TLA022038R5200
WET-K-800 FII	2TLA022038R5300
WET-K-900 FII	2TLA022038R5400
WET-K-1200 FII	2TLA022038R5500
WET-L FII	2TLA022038R5600
WET-T FII	2TLA022038R5700
<b>Colour:</b>	Transparent plastic
<b>Length including lid:</b>	light curtain/light beam + 66 mm
<b>Material:</b>	
Tube	PC
Lid	PEHD-300
Angle bracket	Stainless steel
<b>Max. ambient temperature:</b>	+55°C
<b>Installation adjustment</b>	$\pm 20^\circ$
<b>Protection rating</b>	IP68 (IP69K)

# Blanking programmer BP1

- a quick way to program  
blanking



Programming blanking is made easy by using the Blanking programmer BP1. The BP1 is easily connected between the receiver unit of the light curtain and the cable otherwise connected to the receiver. The blanking object is placed in the light curtain and the button on the BP1 is then pressed. 11 seconds later blanking is programmed for the object.

If the object needs to be changed a new programming is needed.

The unit can stay fitted during operation if required.

## Application:

Program blanking

## Features:

Easy to connect

Can stay fitted during  
operation

## Technical data – BP1

<b>Manufacturer:</b>	ABB AB/Jokab Safety, Sverige
<b>Article number/ ordering data:</b>	BP 2TLA022090R00
<b>Colour:</b>	yellow and black

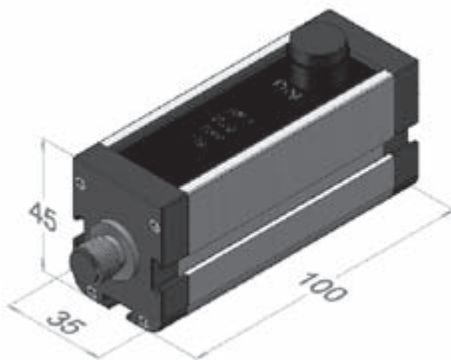

# Laser aligner JSRL-3

## Application:

Alignment of light beams/ curtains



## Features:

Facilitates alignment

When the solution involves one or more mirrors JSRL-3 facilitates alignment of light beams or light curtains. The JSRL-3 is easily secured using the accompanying elasticated tape around the transmitter and receiver unit, and must be placed so that the flat rear of the unit is up against the front glass of the light curtain. When the laser aligner is switched on the red laserspot should be visible at the corresponding unit, even via mirrors.

The JSRL-3 contains two type AAA batteries that are changed by unscrewing the bottom end cap.

## Technical data – JSRL-3

<b>Manufacturer:</b>	ABB AB/Jokab Safety, Sverige
<b>Article number/ ordering data:</b> JSRL-3	2TLA020008R0200
<b>Colour:</b>	Gul och svart

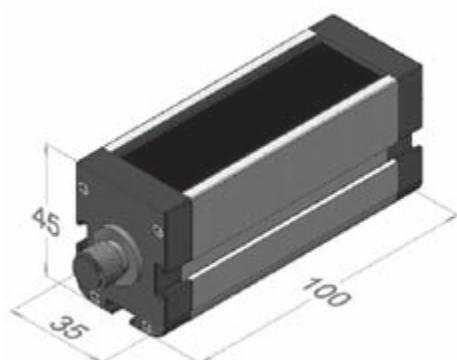

# HR7000C-01 Focus - Connection without and with muting function

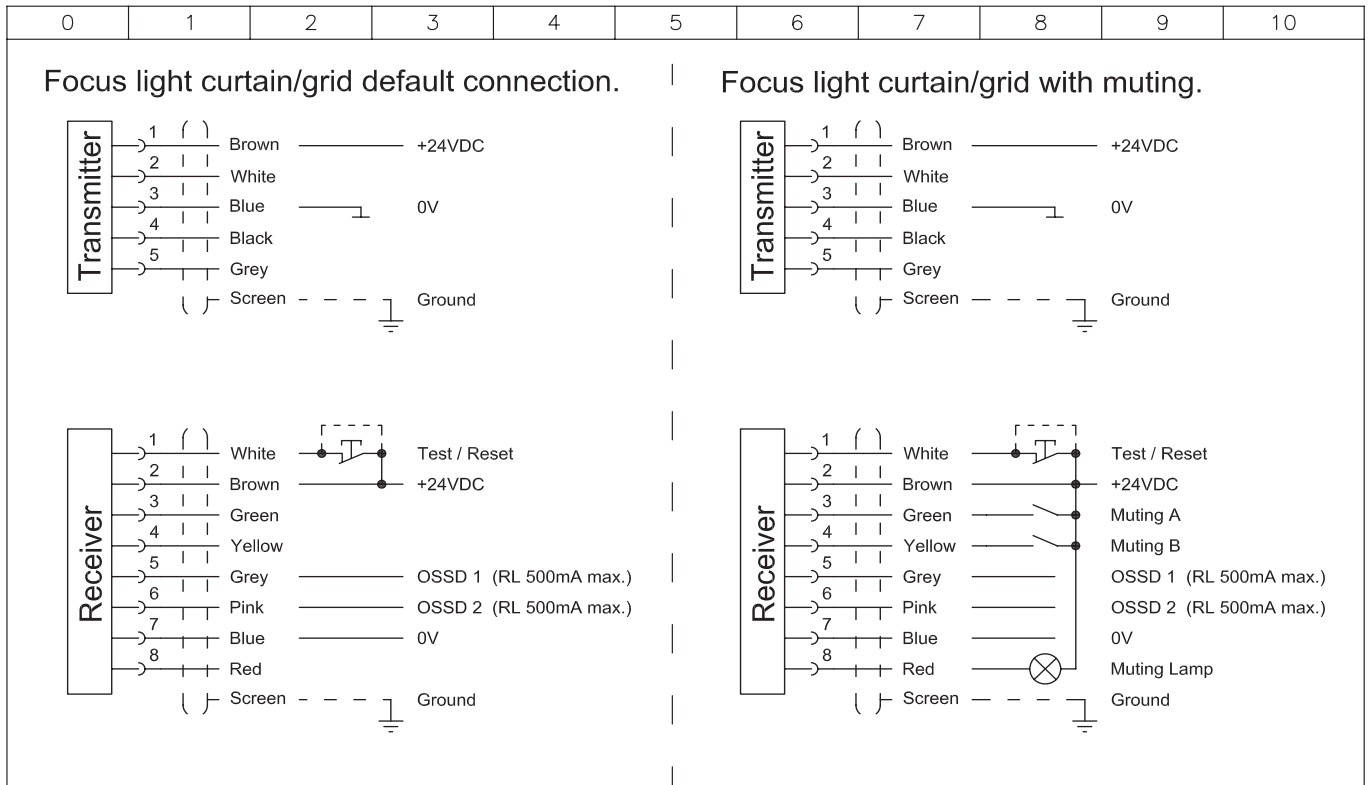

Anmärkning Remark		Konstr Design	Godk	Appr	Datum Date	Blad Sheet
Focus		JS			070411	
Connection without and with muting function.		Ritad Drawn	Sidor	Pages	Ritn nr Drawing no	Forts Cont
Inkoppling utan och med muting funktion.		JS	1	1	HR7000C-01	

It is the user's responsibility to ensure that all control devices are correctly installed, cared for and operated to meet all applicable European, national and local codes/regulations. Specifications subject to change without notice.

# HR7000E-01 Focus - Connection with pre-reset function

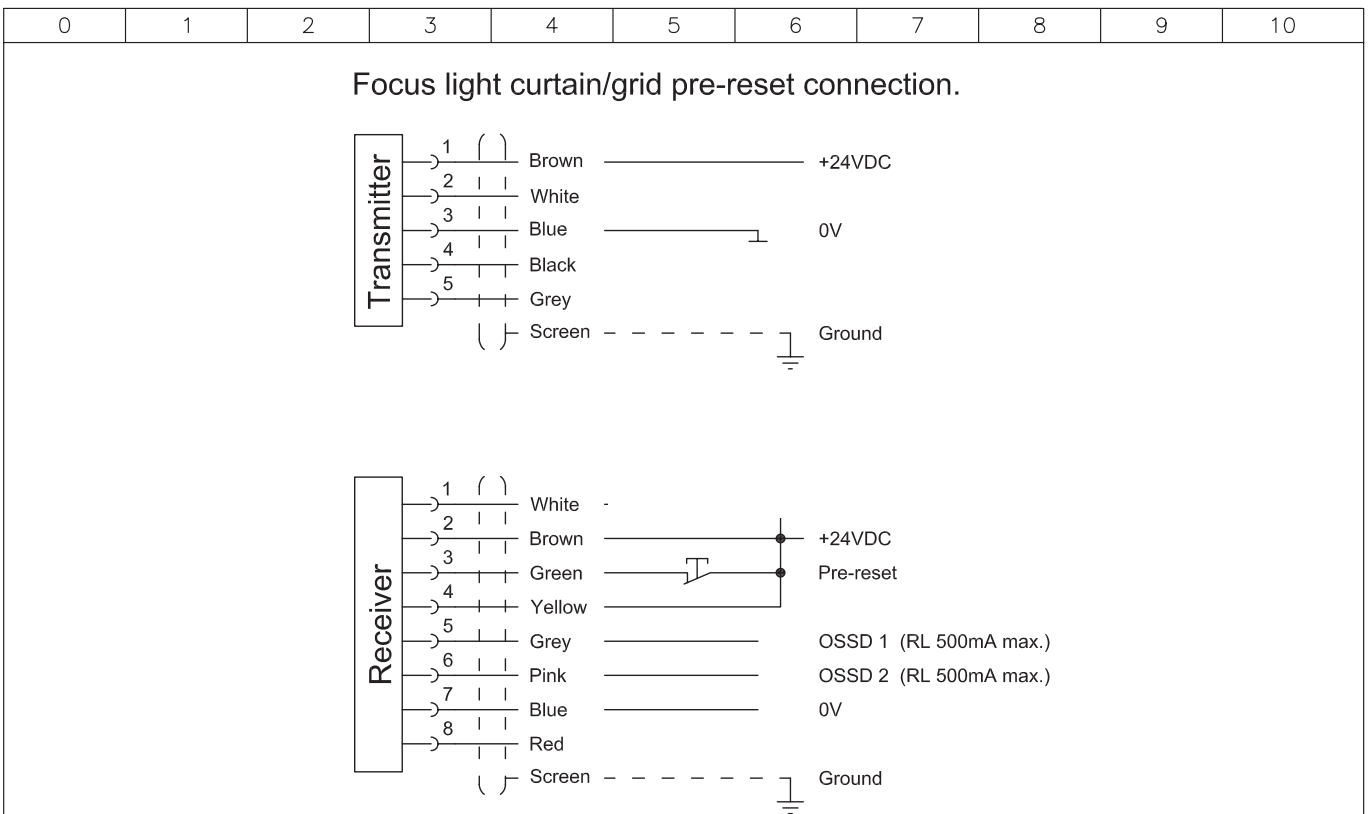

Anmärkning Remark		Konstr Design	Godk	Appr	Datum Date	Blad Sheet
Focus		JS			070411	
Connection with pre-reset function.		Ritad Drawn	Sidor	Pages	Ritn nr Drawing no	Forts Cont
Inkoppling med pre-reset funktion.		JS	1	1	HR7000E-01	

It is the user's responsibility to ensure that all control devices are correctly installed, cared for and operated to meet all applicable European, national and local codes/regulations. Specifications subject to change without notice.

# HR7000F-01 Focus - Connection with muting to safety relay

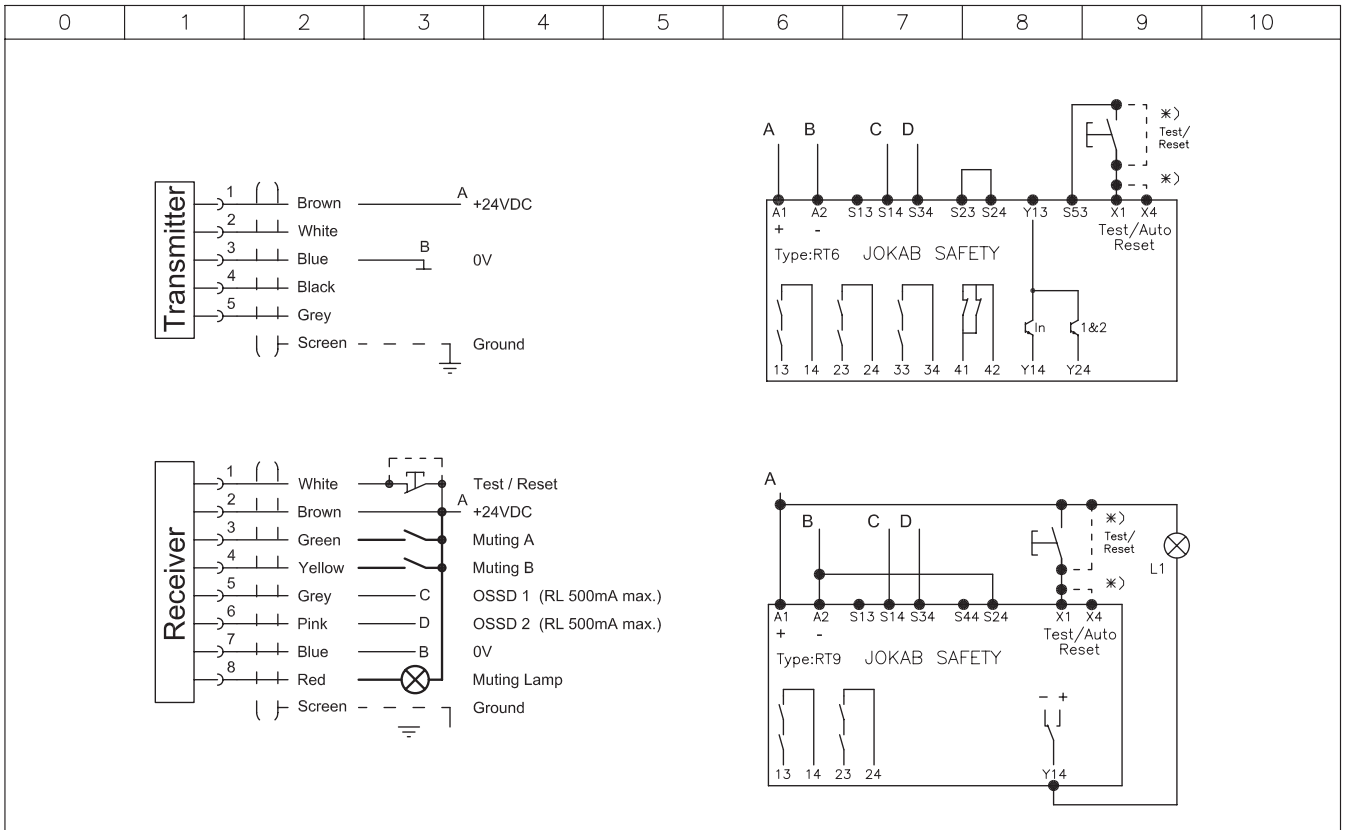

Anmärkning Remark Focus Connection with muting to safety relay. Inkoppling med muting till säkerhetsrelä.	Konstr Design JS	Godk Appr	Datum Date 070411	Blad Sheet
	Ritad Drawn JS	Sidor Pages 1	Ritn nr Drawing no HR7000F-01	Forts Cont

It is the user's responsibility to ensure that all control devices are correctly installed, cared for and operated to meet all applicable European, national and local codes/regulations. Specifications subject to change without notice.

# HR7000G-01 Focus - Connection with MFII-T/MFII-L units

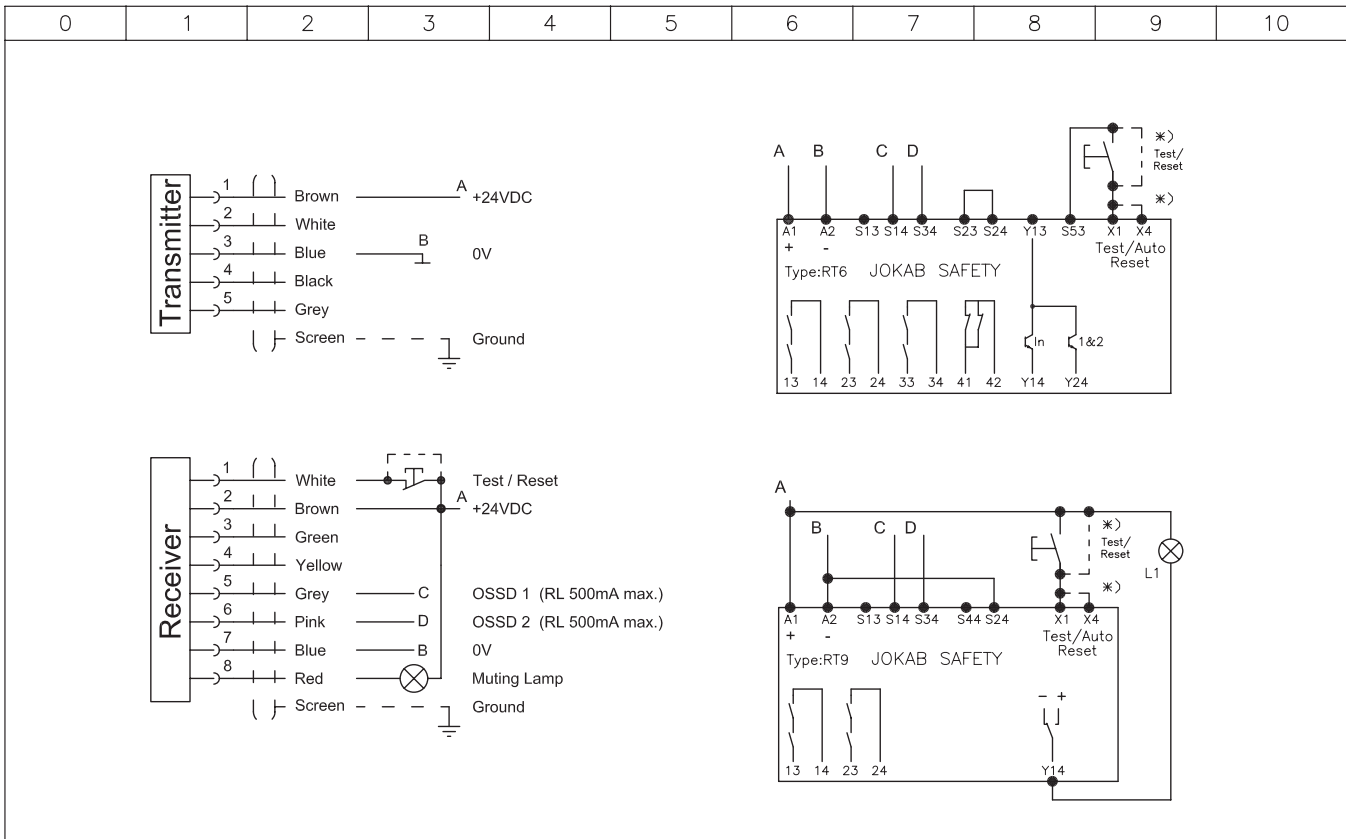

Anmärkning Remark Focus Connection with MF-T / MF-L units. Inkoppling med MF-T / MF-L enheter.	Konstr Design JS	Godk Appr	Datum Date 070411	Blad Sheet
	Ritad Drawn JS	Sidor Pages 1	Ritn nr Drawing no HR7000G-01	Forts Cont

It is the user's responsibility to ensure that all control devices are correctly installed, cared for and operated to meet all applicable European, national and local codes/regulations. Specifications subject to change without notice.



# HR7000H-01 Focus - Connection with FMC/Tina Interface

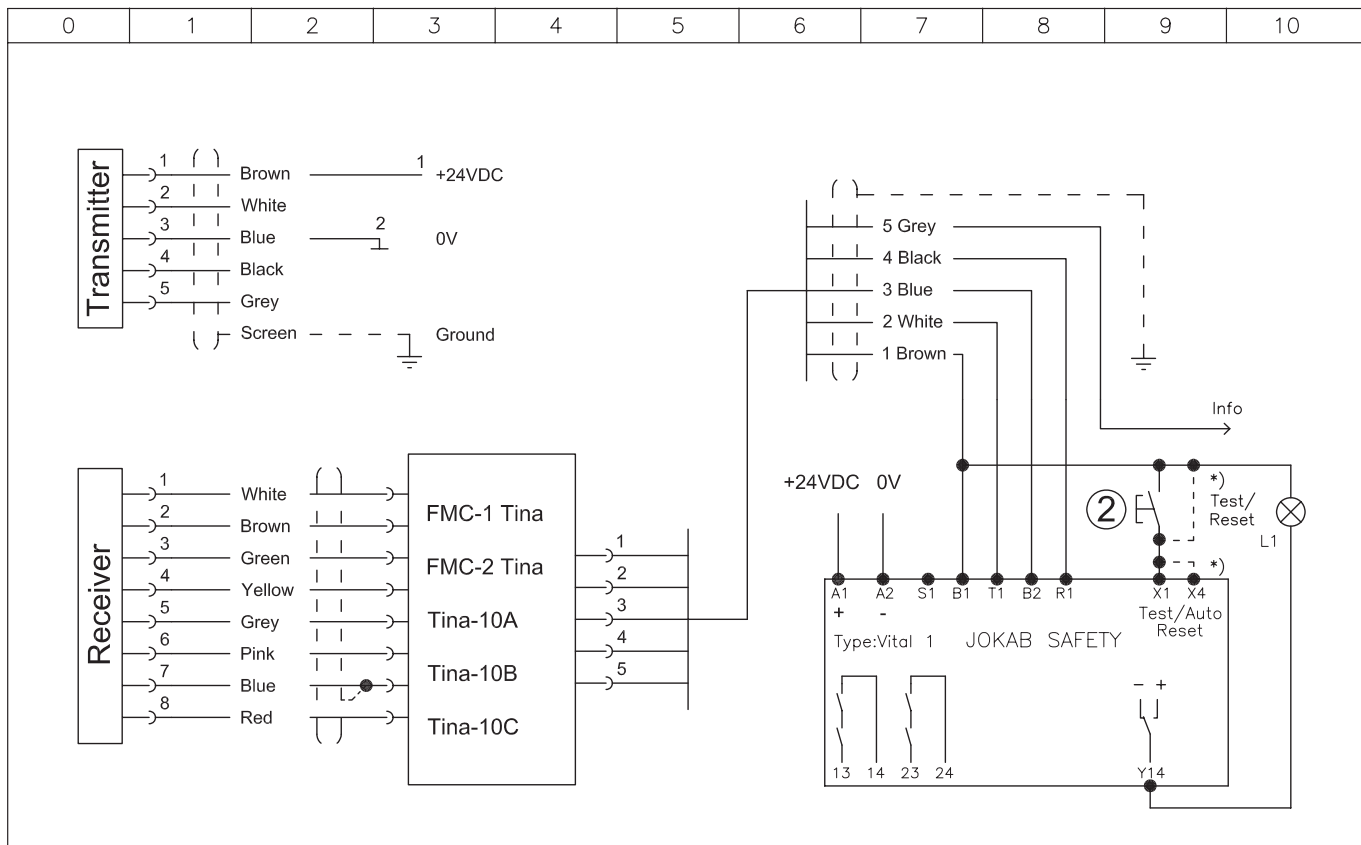

Anmärkning Remark	Focus Vital connection with FMC / Tina interface. Vital anslutning med FMC / Tina interface.	Konstr Design JS	Godk Appr JS	Datum Date 070411	Blad Sheet
		Ritad Drawn JS	Sidor Pages 1	Ritn nr Drawing no HR7000H-01	Forts Cont

It is the user's responsibility to ensure that all control devices are correctly installed, cared for and operated to meet all applicable European, national and local codes/regulations. Specifications subject to change without notice.

# HR7000I-01 FMC

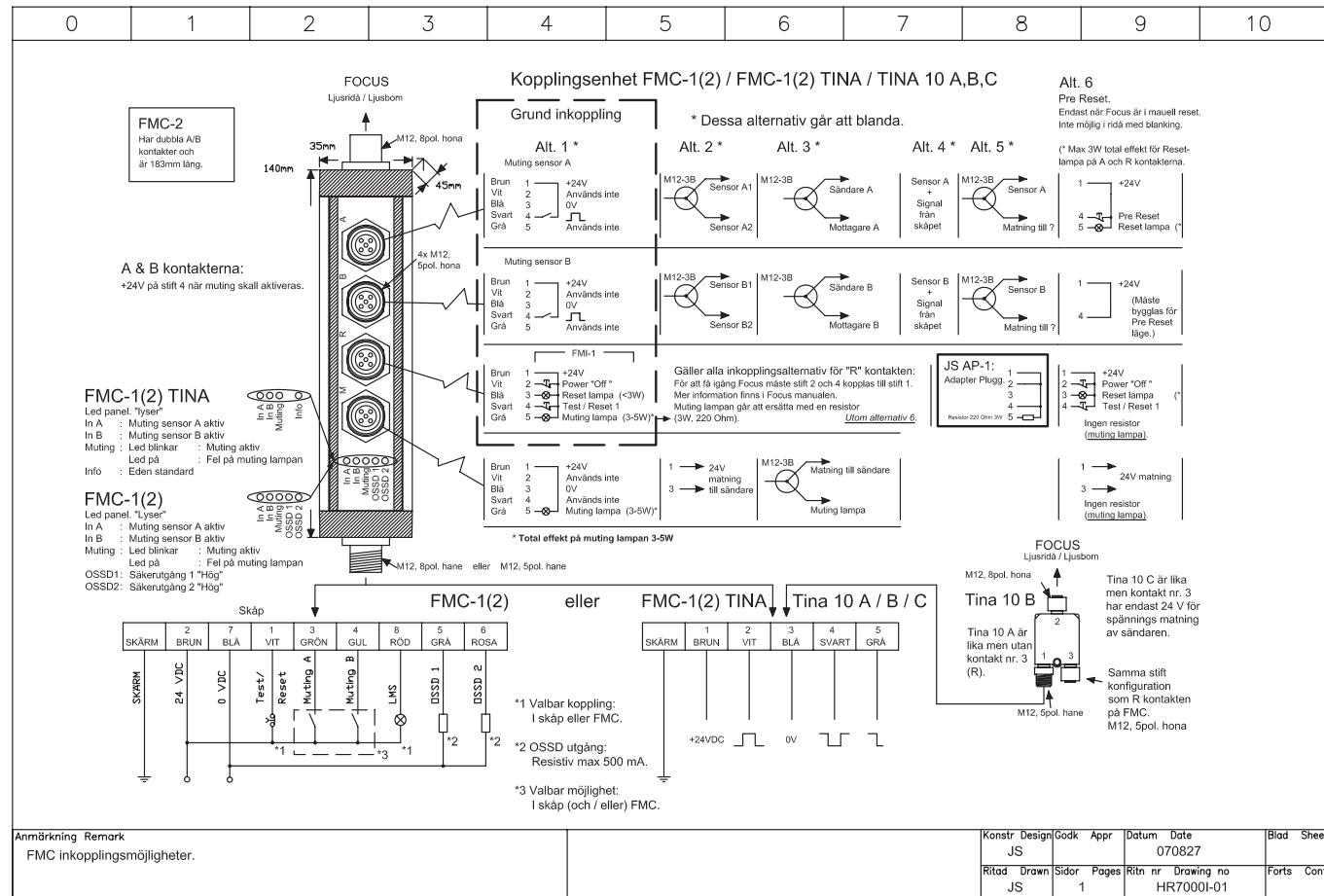

Anmärkning Remark	FMC inkopplingsmöjligheter.	Konstr Design JS	Godk Appr JS	Datum Date 070827	Blad Sheet
		Ritad Drawn JS	Sidor Pages 1	Ritn nr Drawing no HR7000I-01	Forts Cont

It is the user's responsibility to ensure that all control devices are correctly installed, cared for and operated to meet all applicable European, national and local codes/regulations. Specifications subject to change without notice.

# HR7000J-01 FMC-1 or FMC-1 Tina with muting sensors and reset unit

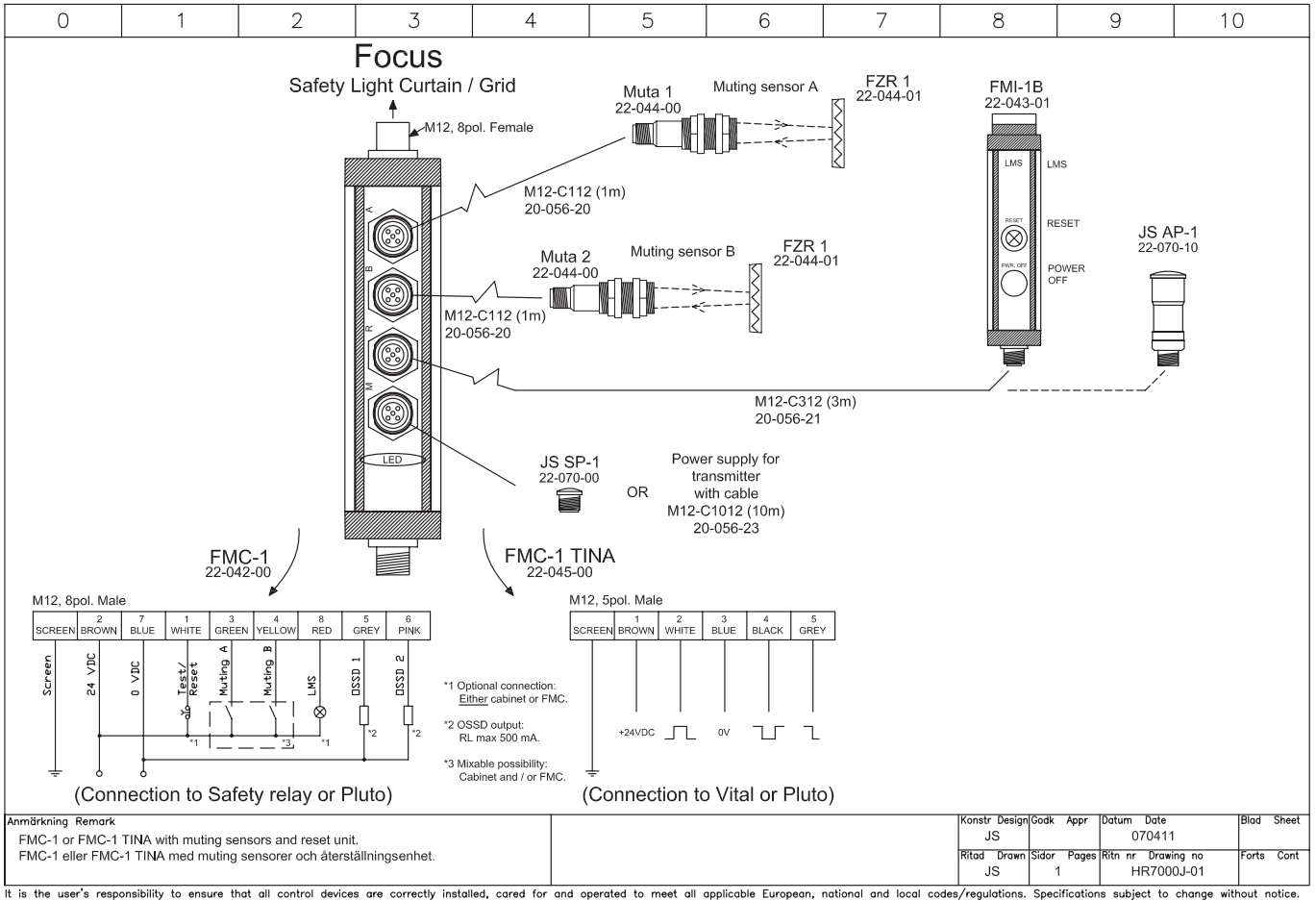

# HR7000K-01 FMC-1 or FMC-1 Tina connected with Pre Reset

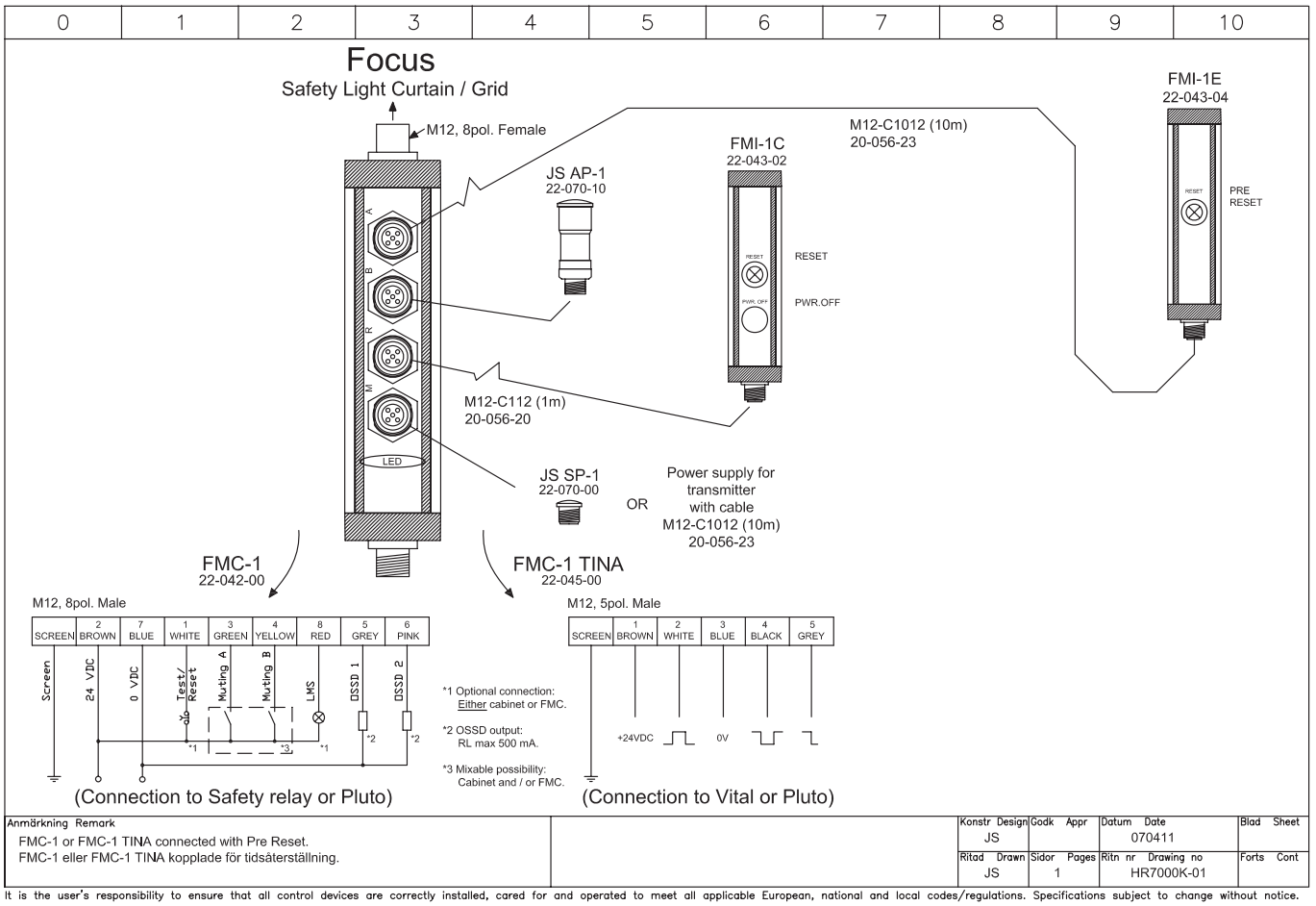

# HR7000L-01 Tina 10A, 10B and 10C connection example

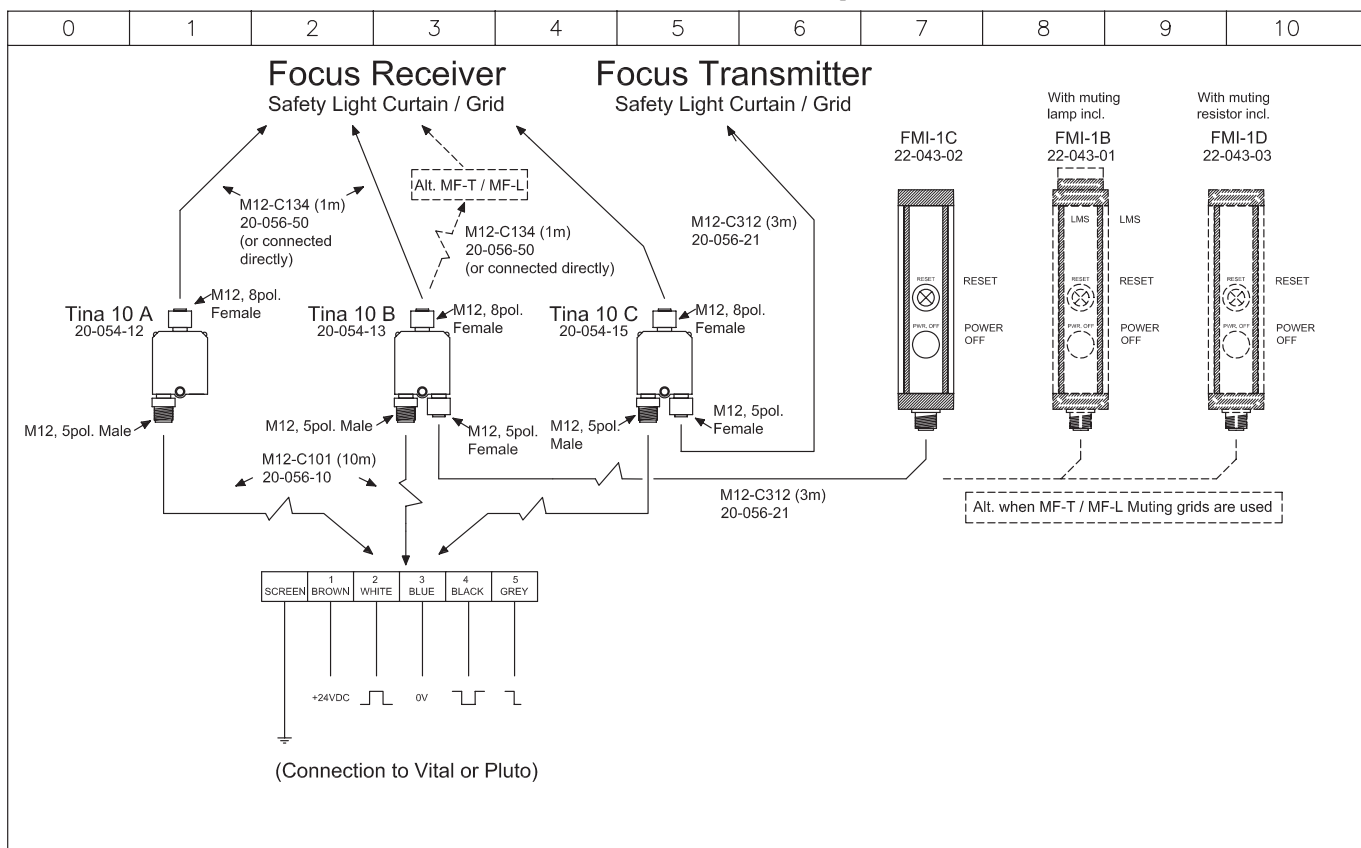

Anmärkning Remark TINA 10A, 10B and 10C connection example. TINA 10A, 10B and 10C inkopplingsexempel.	Konstr Design	Godk	Appr	Datum Date	Blad Sheet
	Ritad Drawn	Sidor Pages	Ritn nr Drawing no	070411	
	JS	1	HR7000L-01		

It is the user's responsibility to ensure that all control devices are correctly installed, cared for and operated to meet all applicable European, national and local codes/regulations. Specifications subject to change without notice.

# HR7000M FRM-1 - Changing OSSD outputs to relay contacts

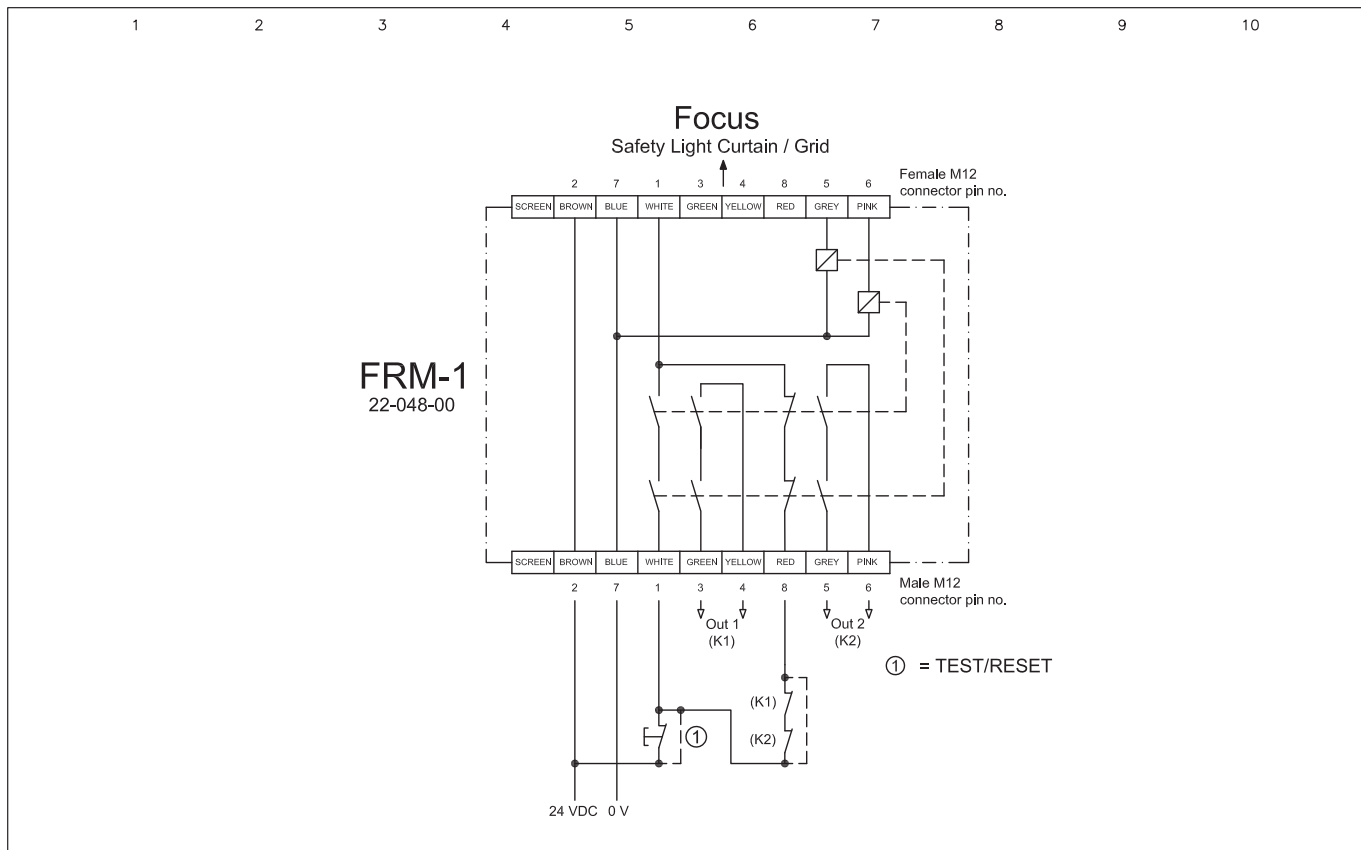

Anmärkning Remark FRM-1. Konverterar OSSD utgångar till reläkontakter. FRM-1. Changing OSSD outputs to relay contacts.	Konstr Design	Godk	Appr	Datum Date	Blad Sheet
	Ritad Drawn	Sidor Pages	Ritn nr Drawing no	20090310	
	JS			HR7000M	

# HR7000-01 Connection example FMC/FMI

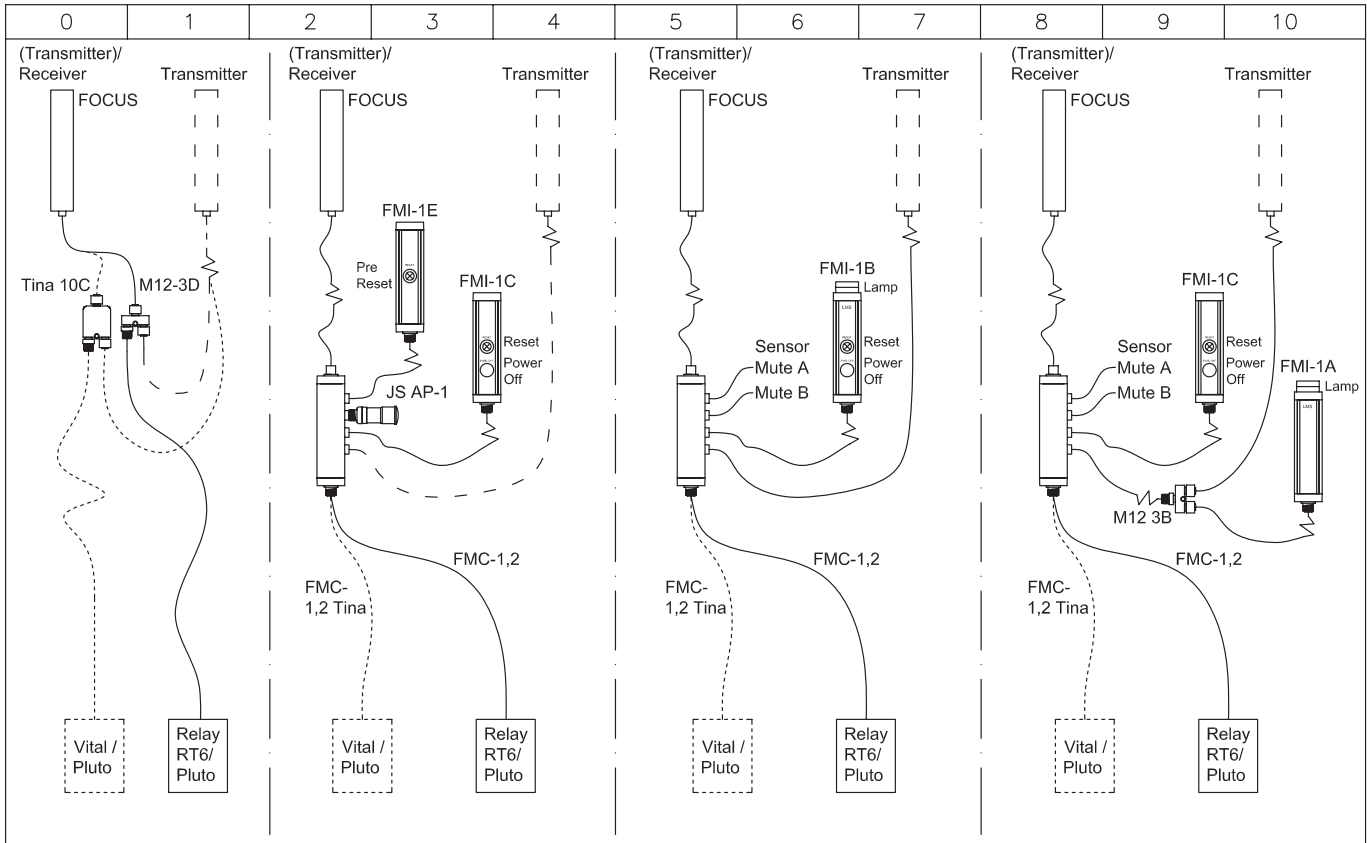

Anmärkning Remark		Konstr Design	Godk Appr	Datum Date	Blad Sheet
Kopplingsexempel FMC / FMI. Connection example FMC / FMI.		JS		070411	
Ritad Drawn	Sidor Pages	Ritn nr Drawing no	Forts Cont		
JS	1	HR7000-01			

It is the user's responsibility to ensure that all control devices are correctly installed, cared for and operated to meet all applicable European, national and local codes/regulations. Specifications subject to change without notice.

# HR7000P Cable connection example

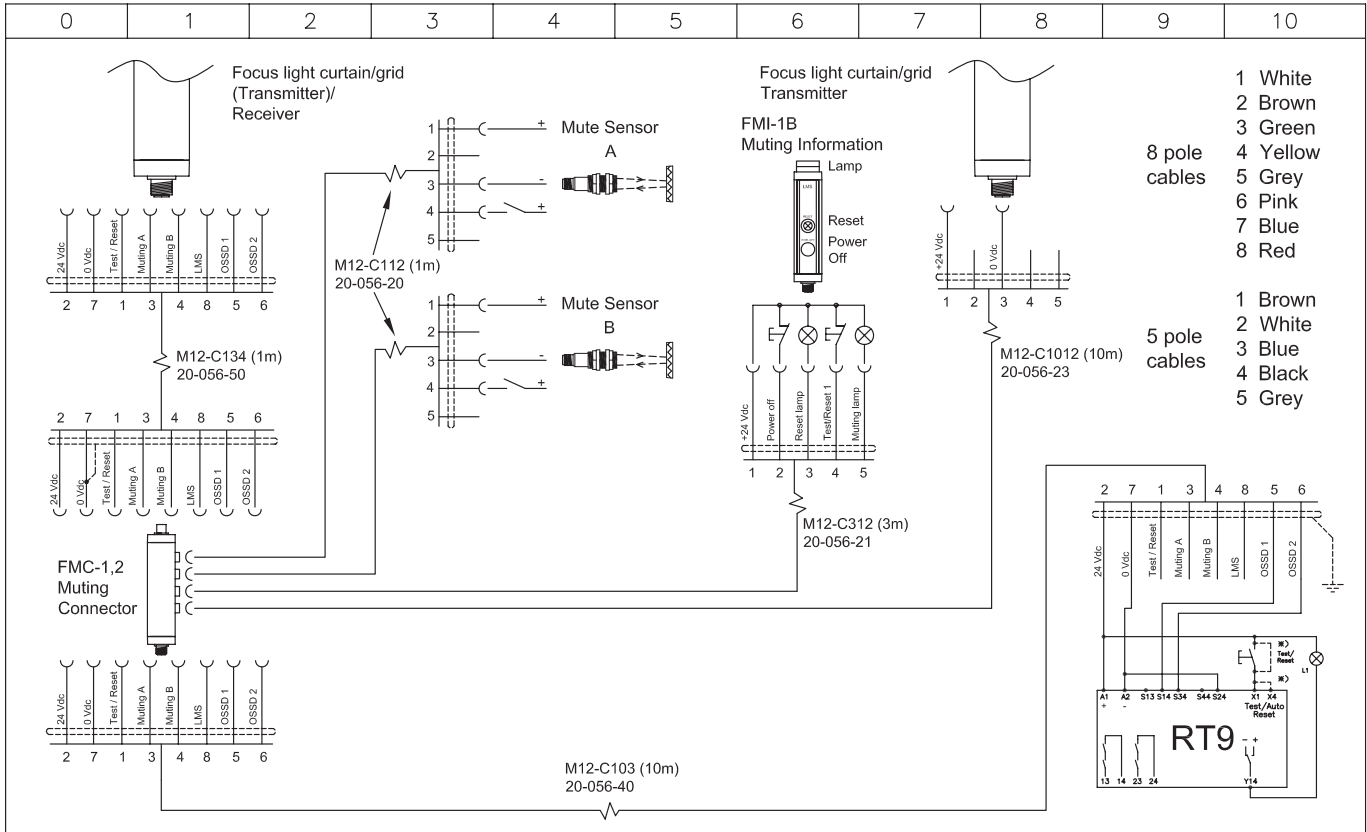

Anmärkning Remark		Konstr Design	Godk Appr	Datum Date	Blad Sheet
Kabel kopplingsexempel. Cable connection example.		JS		050513	
Ritad Drawn	Sidor Pages	Ritn nr Drawing no	Forts Cont		
JS	1	HR7000P			

It is the user's responsibility to ensure that all control devices are correctly installed, cared for and operated to meet all applicable European, national and local codes/regulations. Specifications subject to change without notice.



# Safety Light Beam Spot



## A light beam for the highest safety level

The light beam is available in two versions Spot 10 for distances up to 10 m and Spot 35 for up to 35 m. The light beams can be mounted at different heights and be angled around a machine using our mirrors and brackets.

Spot and Vital/Pluto in combination fulfils the requirements for PL e according to EN ISO 13849-1 and type 4 according to EN 61496. Several light beams, Eden sensors and emergency stops can be connected in series achieving the high safety level for the safety circuit. A number of solutions for bypassing of light beams for material transport are available.

For indication there are LED's on the transmitter and on the receiver which indicate 'contact' between transmitter and receiver and safety status. The 'contact' information is available via the light beam receiver connection cables.

## Function

The Spot light beam is supervised by the Vital safety controller or by the Pluto safety-PLC. A unique coded signal is sent out from the control unit to the transmitter (Spot T). The signal which comes back from the receiver (Spot R) is then compared in the Vital/Pluto. If the correct coded signal is received the Vital/Pluto switches the necessary safety output contacts to permit dangerous machine movements. Coding guarantees that no output signals can be produced by light from other sources, interference or faults in components in the transmitter or receiver. The light beam is dynamically supervised which means that if the signal stops pulsating at the correct frequency it is immediately detected. By means of coding, the dynamic signal can pass between up to 6 pairs of transmitters and receivers, with only one pair needing to be electrically connected to a Vital.

## Approvals:



## Application:

Photoelectric guarding of an entrance or around a risk area

## Features:

- Safety level Type 4 according to EN 61496
- Versatile mounting
- LED indication
- Protection class IP67
- 10 m or 35 m range
- Bypassing possibility
- Light beam, emergency stop and Eden in the same safety circuit together with Vital/Pluto achieves PL e according to EN SO 13849-1

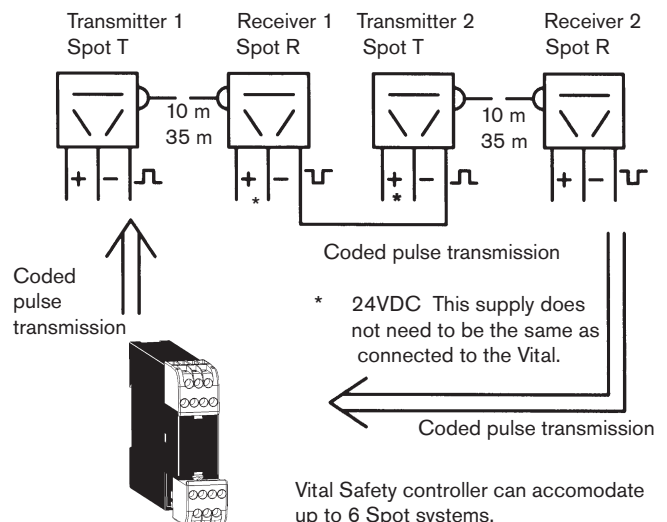



## Mounting and alignment – Spot

### Safety distance

The basic principle is that dangerous machine movements should be stopped before a person reaches the dangerous area, which should be at least 850 mm from the light beams. When determining the correct safety distance the stopping time of the machine and the risk level must be taken into account (see also EN ISO 13855). Contact us for further information.

### Accessories and Mounting

The Spot light beam can be mounted using a variety of brackets, posts and mirrors. See ordering list for further information.

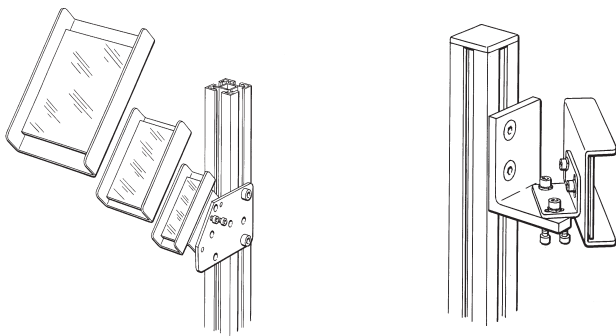

*Different sizes of mirrors, mounting brackets and profiles are available. See component ordering list.*

**Note.** Every mirror reduces the sensing distance of the beam by approx. 20%.

### Alignment

When aligning the light beam, look towards the transmitter. In the lens will be seen a strong red light. When this light is seen from the receiver (via mirrors if fitted) the light beam is basically aligned. The LED on the receiver is on when the receiver is aligned with the transmitter. By moving the transmitter up/down and left/right the best alignment can be found.

When vertically mounting, (as shown in the diagram) the receiver should be mounted above the transmitter as this will simplify the alignment and minimise the risk of extraneous light disturbance. In exceptional light disturbance environments the received light can be adjusted by a screw on the rear of the Spot 35 receiver. On Spot 10 this adjustment can be made on the transmitter. To make the alignment even easier the Laser Aligner (JSRL2) can be used for Spot 35. The laser has visible light (class IIa) and is easy to mount for aligning. Supply to the Laser Aligner is taken from the Spot 35 T/R connector.

**NOTE!** When using Laser aligner **do not** look directly into the laser. Observe all necessary precautions when using laser devices, failing to do so can result in eye damage.

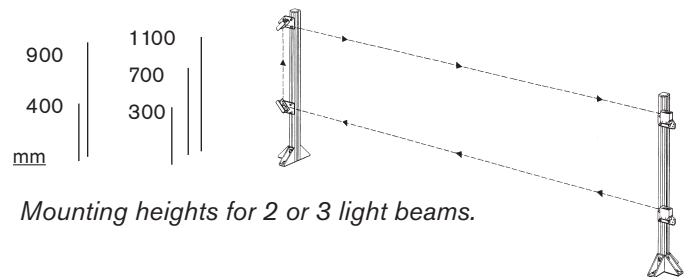
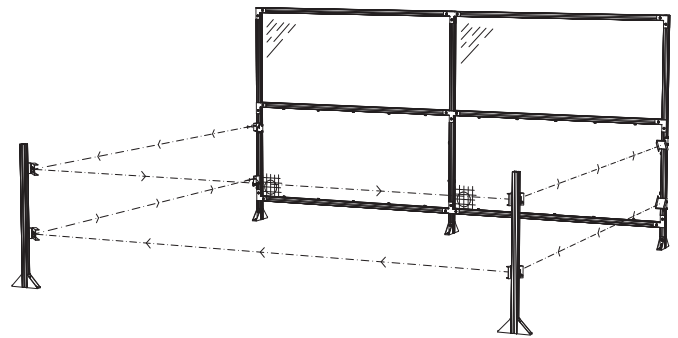

*Mounting heights for 2 or 3 light beams.*

### JSM64

*Pivot M18 bracket for Spot 10 or MUTE R (FSTR1) for example*

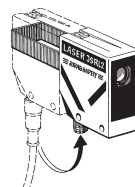
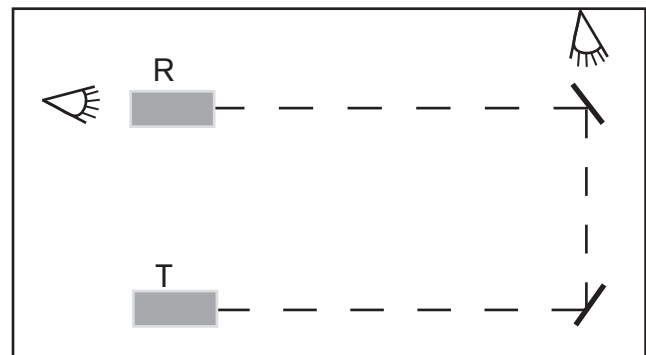
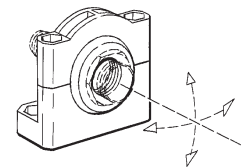

*Laser aligner JSRL2 for light beam Spot T/R.*

Technical data - Spot	
<b>Manufacturer</b>	ABB Jokab Safety, Sweden
<b>Article number/Ordering data</b> Spot 10 T/R Spot 35 T/	2TLA020009R0600 2TLA020009R0500
<b>Safety level</b> EN/IEC 61496 EN 954-1 EN ISO 13849-1	Type 4 with Vital/Pluto Category 4 PL e
<b>PFH<sub>d</sub></b>	1,14x10 <sup>-8</sup>
<b>Power supply</b>	17 – 27 VDC, ripple ±10%
<b>Current consumption</b> Transmitter: Receiver:	< 25 mA < 15 mA
<b>Output currents</b> Info. output Dynamic signal out	10 mA max. 30 mA max.
<b>Light source</b>	Red visible light, 660 nm, <±2°
<b>Optical power</b> Spot10: Spot 35:	< 0,1 mW < 0,2 mW
<b>Function indication</b> Green LED on transmitter (power): Green LED on receiver status: On: Flashing: Off:	Power supply OK  Alignment OK, safety circuit closed Alignment OK, earlier safety circuit open Beam interrupted, safety circuit open
<b>Protection class</b>	IP 67
<b>Range</b> Spot 10: Spot 35:	0 - 10 m 0 - 35 m
<b>Range adjustment</b> Spot 10: Spot 35:	Trim pot. on transmitter Trim pot. on receiver
<b>Installation</b> Spot 10: Spot 35:	2xM18 nuts (provided) Either via mounting holes in the casing or with angle bracket JSM63 (provided)
<b>Operating temperature range</b>	-25°C – +65°C
<b>Cable connection</b>	M12 fixed connector
<b>Casing Material</b> Spot 10: Spot 35:	Steel housing with polyacryl lens protection. Polyamide housing with polyacryl lens protection.

<b>Colour</b> Spot 10: Spot 35:	Steel grey Yellow/black
<b>Weight</b> Spot 10: Spot 35:	2 x 21 g 2 x 100 g
<b>Connections</b> Transmitter: Brown (1) White (2) Blue (3) Receiver: Brown (1) White (2) Blue (3) Black (4) Grey (5)	+24 VDC Dynamic signal in 0 VDC +24 VDC  0 VDC Dynamic signal out Info output
	24 VDC when LED is green or flashing (tolerance -2 VDC) 0 VDC when LED is off (tolerance +2 VDC)
<b>Conformity</b>	European Machinery Directive 2006/42/EC <b>CE</b> EN ISO 12100-1:2003 EN ISO 12100-2:2003 EN 60204-1:2006 + A1:2009 EN 954-1:1996 EN ISO 13849-1:2008 EN 62061:2005 EN 61496
<b>Certifications</b>	TÜV Nord 

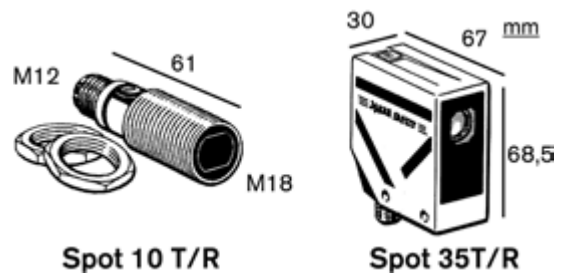

# Connection of Spot T/R to Vital1

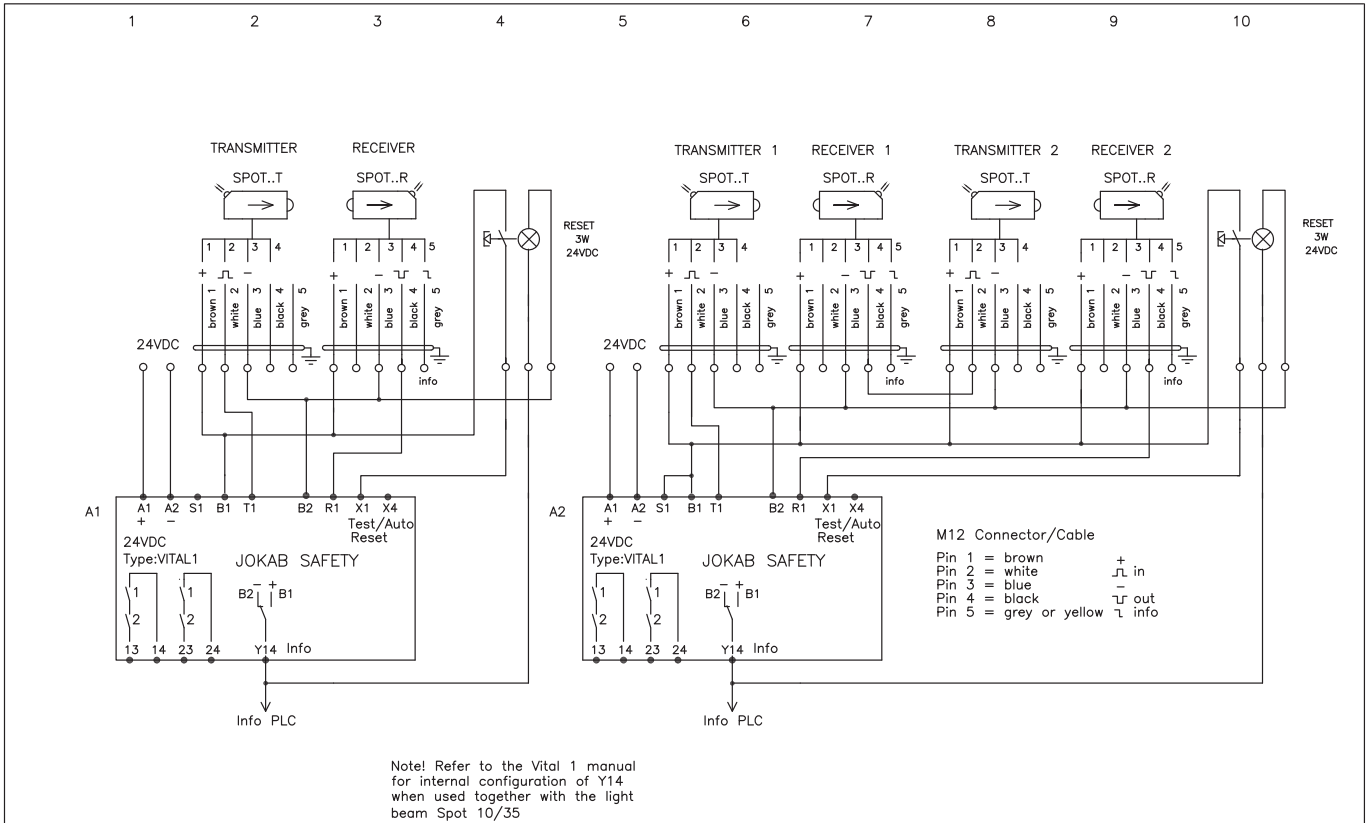

Anmärkning Remark	Konstr Design	Godk Appr	Datum Date	Blad Sheet
VITAL1 MED LJUSBOM SPOT..	JS		20110318	
VITAL1 WITH SAFETY LIGHTBEAM SPOT	Ritad Drawn	Sidor Pages	Ritn nr Drawing no	Forts Cont
	JS		HD3800A-01	

# Vital 1 with 3 lightbeams Spot

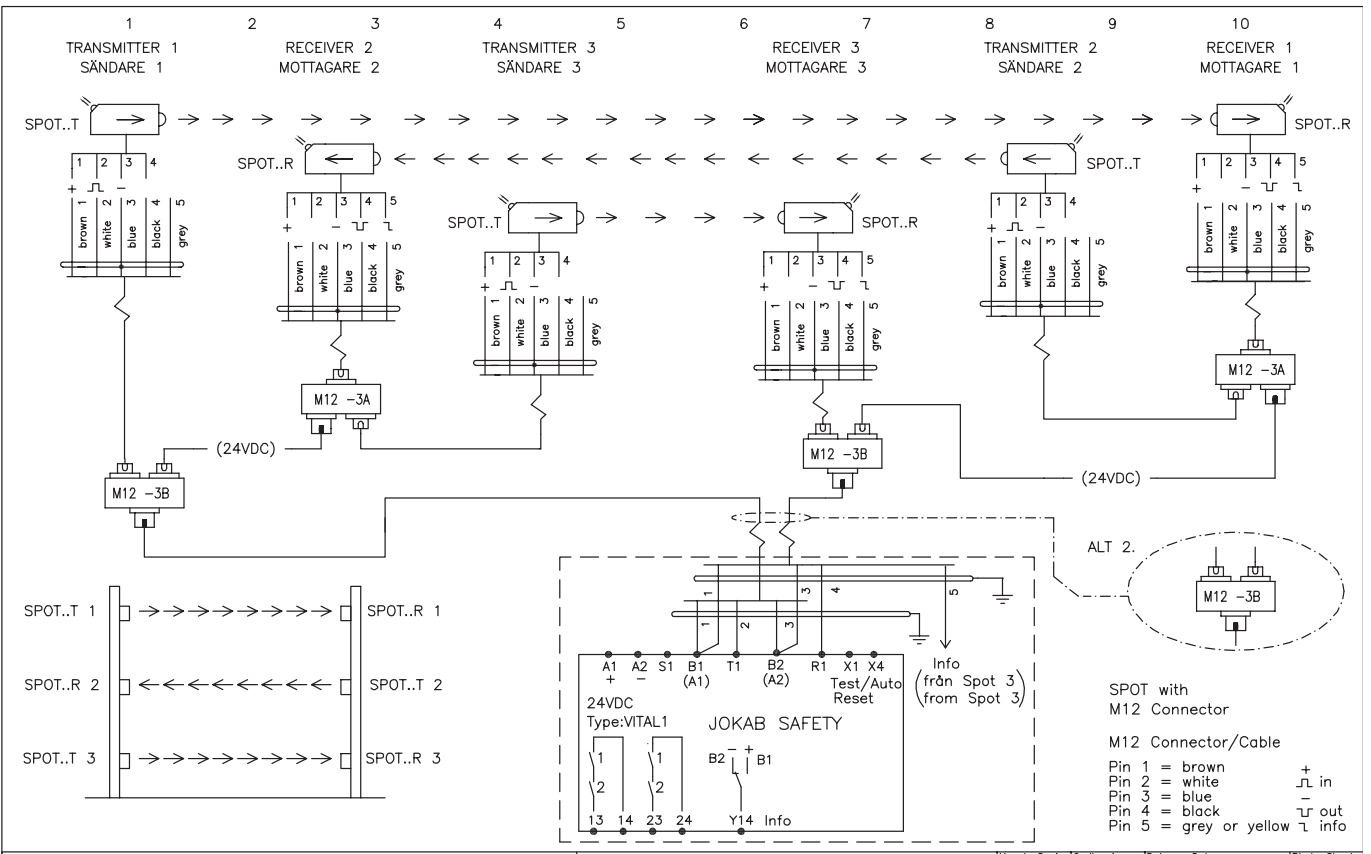

Anmärkning Remark	Konstr Design	Godk Appr	Datum Date	Blad Sheet
VITAL1 MED 3 LJUSBOMMAR SPOT...	JS		020722	
VITAL1 WITH 3 LIGHTBEAMS SPOT...	Ritad Drawn	Sidor Pages	Ritn nr Drawing no	Forts Cont
	JS		HA3306D	

\*For more connection examples see chapters for Vital or Pluto

# Laser scanner

# Look



## A laser scanner that has the ability to scan four individual areas

The Laser Scanner 'Look' has the ability to scan four individual areas. Each area can be programmed individually for the specific application, making it ideal for auto-carriers that need to operate along different paths. The safety level is according to Type 3, EN 61496-3. It is approved for use as personnel protection in robot working areas, conveyor equipment etc. The small design makes it easy to install. Look is not affected by ambient light levels (sun etc) or welding arcs/sparks. The protection fields are quick and easy to create on a PC in a Windows environment. It has four individual programmable protection areas. Each area consists of one personnel protection field with maximum 4 m radius, and one warning field of maximum 15 m radius. Changing between the areas is easily achieved using additional sensors.

## Approvals:



## Application:

Photoelectric guarding of several risk areas

## Features:

- Type 3, IEC61496-3
- Easy to install
- Protected from welding sparks/arcs
- Easy to program
- 4 individual programmable protection areas simultaneously with Pluto

# Software - Look scanner

Function buttons

Dialog box for selecting which area pair to display

Inactive safeguarded area pair 3

Measured area limits

Warning indication, an object is inside the safeguarded area

An object is detected inside the detection area, the machine stops

Active safeguarded area pair 1  
Red: Detection area  
Green: Safeguarded area

## Connection example - Look scanner with RT9

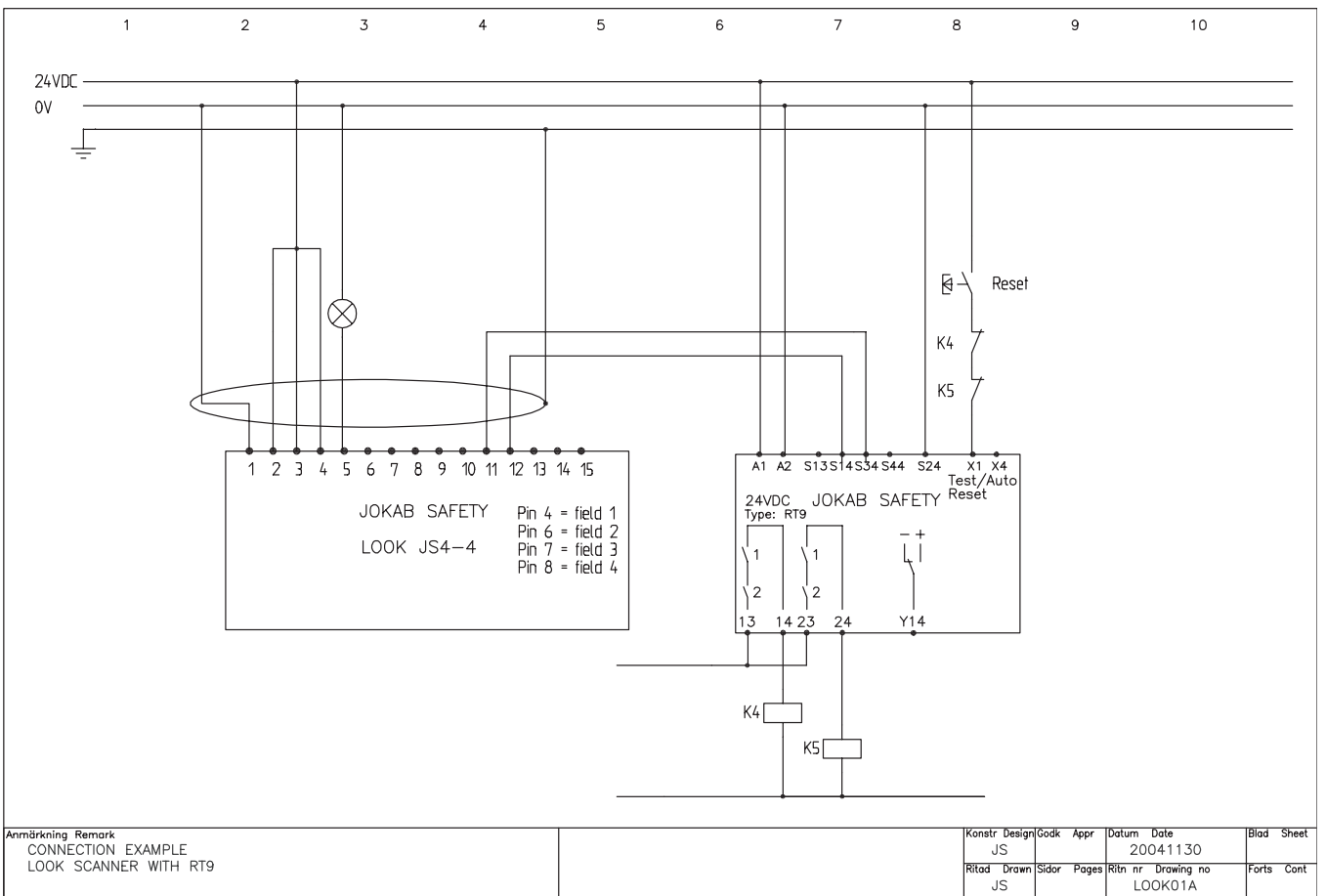

Technical Data – Look	
<b>Article number/ Ordering data</b>	50034195    Look JS4-4
<b>Safety level</b> EN/IEC 61496 EN 954-1 EN ISO 13849-1	Type 3 Category 3 PL d
<b>PFH<sub>d</sub></b>	1,50E-07
<b>General data</b> Scanning rate: Scanning angle: Operating voltage: Transmitter: Current consumption: Angle resolution: Weight: Housing:	25 Scans/sec 190° 24 VDC +20%/ -30% Laserdiode; Protection class 1 approx. 300 mA 0,36° 2 kg H=155 mm, W=140 mm, D=135 mm
<b>Personnel protection field</b> Scanning distance: Area:  Output:  Resolution: Response time: Reflectance factor:	Radius 0.2 - 4 m 4 areas, switchable by 24 VDC input  2 x OSSD; 250 mA; failsafe transistor PNP outputs 24 VDC  70 mm at 4 m 80 ms min 1,8 %
<b>Warning field</b> Scanning distance: Area:  Output: Resolution: Response time: Reflectance factor:	Radius 0 - 15 m 4 areas, switchable by 24 VDC input  PNP-transistor, 24 VDC/100 mA 150 mm at 15 m, ± 20% 80 ms min 20%
<b>Contour measurement</b> Measurement range: Output: Response time: Reflectance factor: Reset: Suitable interface safety relay:	Radius 0- 50 m RS 232/422 80 ms min 20% manual or automatic RT6, RT7, RT9, JSBRT11 or Pluto
<b>Conformity:</b>	Machine directive 2006/42/EG EN ISO 12100-1/2, EN 954-1, EN ISO 13849-1, -2, EN 61496-1

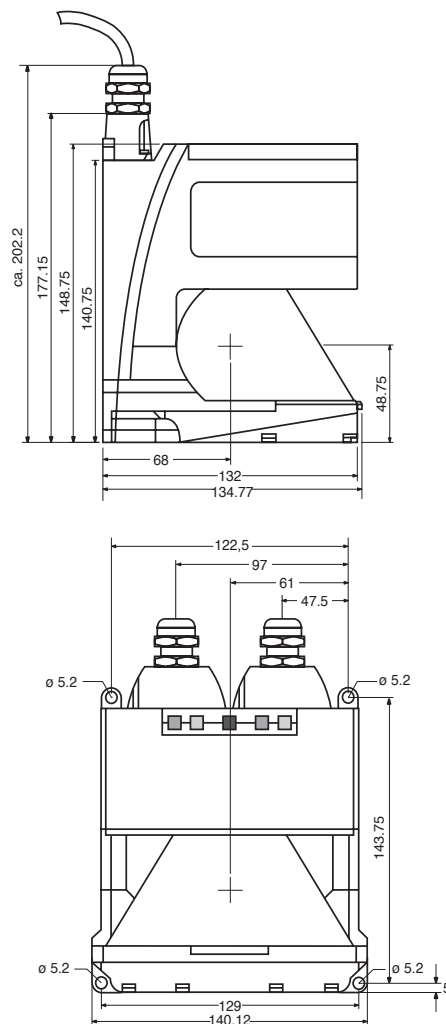





# Stopping time and machine diagnosis tool

## Smart



<b>Contents</b>	<b>Page</b>
<i>Stopping time</i> _____	<b>8:2</b>
<i>Stopping time and Machine Diagnosis Tool - Smart</i> _____	<b>8:3</b>
<i>Smart Manager</i> _____	<b>8:4</b>
<i>Smart and accessories</i> _____	<b>8:6</b>

Descriptions and examples in this book show how the products work and can be used. This does not mean that they can meet the requirements for all types of machines and processes. The purchaser/user is responsible for ensuring that the product is installed and used in accordance with the applicable regulations and standards. We reserve the right to make changes in products and product sheets without previous notice. For the latest updates, refer to [www.abb.com/lowvoltage](http://www.abb.com/lowvoltage). 2011.

# Stopping time

## Why measure stopping time?

– to find out which safety arrangements can be used in a certain area around a machine, and where they should be located.

### Stopping time

The safety distance (how far away from the risk area a safety component must be placed) is based upon the machine's stopping time. The basic idea is that a safety component should be placed so far from the risk area that it is not possible to enter the area before the machine has stopped.

The stopping time for manually operated machines is especially important when light beams and light curtains are used as safety components. By reflex action the operator tries to grab or adjust if something has gone wrong in the machine tool, even if the machine has started. It is then imperative that the machine stops before the hand reaches the risk area. A short stopping distance is also of importance for getting good ergonomics.

Grabbing or adjusting is also common when using automatic machines. Usually this is done to prevent production down-time by quickly adjusting a work piece. The stopping time is also of great importance if someone trips and falls into the machine.

Stopping time, walking speed (1.6 m/s) and hand speed (2.0 m/s) is used for the calculation of safety distances. Sometimes a fixed minimum distance is also used. See the standard EN ISO 13855 for more details on the calculation of safety distances.

### Stopping distance

For safety contact strips it is extra important that the stopping distance is monitored. An incorrect stopping distance could in many cases result in very high risks. The stopping distance is also needed during area limiting e.g. for robots when dividing the working area into sectors.

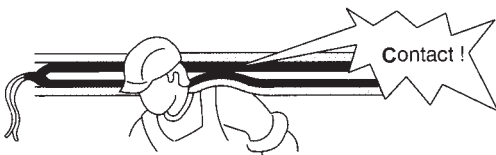

*For door sensitive edges, it is important that the stopping distance is shorter than the soft part of the sensitive edge.*

### Regulations and standards

It is also important to measure the stopping time, to meet the requirements set by the machinery standards, directives and regulations. Here we can help, with our long experience in the practical application of regulations and standards, from the viewpoints of both the authorities and production. In addition we collaborate with the standardisation committees responsible for producing these standards. One example is EN ISO 13855, which deals with the placing of safety



*Where the safety distance is small, one can for example sit close to the machine and work, as in the picture on the left. If the safety distance is greater, it may be necessary to approach the machine to intervene, and also perhaps use additional protection to prevent starting when someone is within the protected distance.*

devices around a machine based on its stopping time. The standard is general for all types of machinery, although for some, where there is a harmonised C standard, the requirements for minimum distance and stopping time measurement will apply. In the case for example of mechanical press tools there is also a requirement in EN 692 for how stopping time measurements are to be performed, and in the case of hydraulic press tools this is in EN 693.

### Annual checks

Wear in a machine is something that can affect braking and motors, which means that the stopping time of a machine can change with time. Certain other changes in a machine, such as changing the weight of a workpiece or alterations in pneumatic pressure, can also affect the stopping time. For these and other reasons it is important to perform an annual check on the stopping time.

### How the stopping time affects the choice of protective equipment – an example

There was a case where we measured the stopping time of the rollers in a textile industry company. The company had planned to place light beams or a light curtain in front of the rollers to prevent the operators from being caught in the material and dragged in. The stopping time measurement showed that it took over one second for the rollers to stop. During this time the material was pulled in by almost two metres. In order to obtain sufficient protection distance, the light beams would have needed to be positioned almost three metres from the machinery, and a light curtain about two metres away. The factory did not have so much space, nor was it realistic. The solution became instead vertical sliding safety barriers.

# Stopping time and Machine Diagnosis Tool

# Smart

Approvals:



Smart shows graphs/values for:

- Stopping time
- Stopping distance
- Speed
- Position of stopping signal

Features:

- Easy to use
- Measurements with or without electrical connection
- Ideal for machine performance diagnosis
- Calculation of correct safety distances



## Smart is ideal for safety supervision and for diagnosis of machine operation

Smart has many valuable features for machine diagnosis:

- Graphic presentation of measurements
- Easy to analyse stopping characteristics and movement
- Gives parameters for safety design (e.g. stop time)
- Calculates minimum allowed safety distance
- Shows how the stop distance can be optimised
- Electrical reaction time and mechanical/hydraulic breaking can be identified and analysed
- Digital in/out signals and analogue inputs

Smart is perfect for periodic monitoring of safety parameters and other conditions for the maintenance and troubleshooting of machines. Because Smart can compare old and new graphs, it becomes easy to find out the reasons for machine malfunctions. One can also supervise machines during operation and compare how they perform over time.

## Stopping units and sensors

Smart is a further development of our well established JSSM1 Stopping Analyser. All the stopping units and sensors for the JSSM1 can also be used with Smart. The amount of connection possibilities have also increased. Smart has 9 digital I/O, one input for an incremental sensor (for position and speed) and two analogue inputs. This makes it easy to measure sequences in conjunction with motion lapse and other analogue values.

## Webbsupport - Smart

On our web site <http://customer.jokabsafety.com> we have a special page for you as a Smart customer. Here you can keep up to date by downloading the latest version of Smart Manager, manuals, drive routines or read the FAQs.



# Smart Manager

Smart is controlled in real time by a computer using the Smart Manager program. This performs measurements, and the measured data can be saved and analysed. The measurements are saved in an SQL database, with the ability to export data to Microsoft Excel if necessary. The program calculates the stopping time and protective distance, and can print out the results, together with a graph of the event sequence. Smart Manager is available in several languages: English, Swedish, Danish, German, French, Czech and Polish. Translation into other languages can easily be arranged as necessary. The program is free, and is available for downloading from our web site when purchasing equipment to measure stopping times.

## Benefits:

- Simple program structure
- Shows the entire stop sequence
- Provides a machine movement "fingerprint"
- Compares measurements
- Calculates stopping time
- Saves measurements to a database
- Exports measured data to Excel
- Prints out a complete measurement report



Start menu



Measuring form

- Current values from sensors and the system
- Start conditions
- Stop signal conditions
- Shutdown conditions
- Measuring settings can be saved

Stop signal given

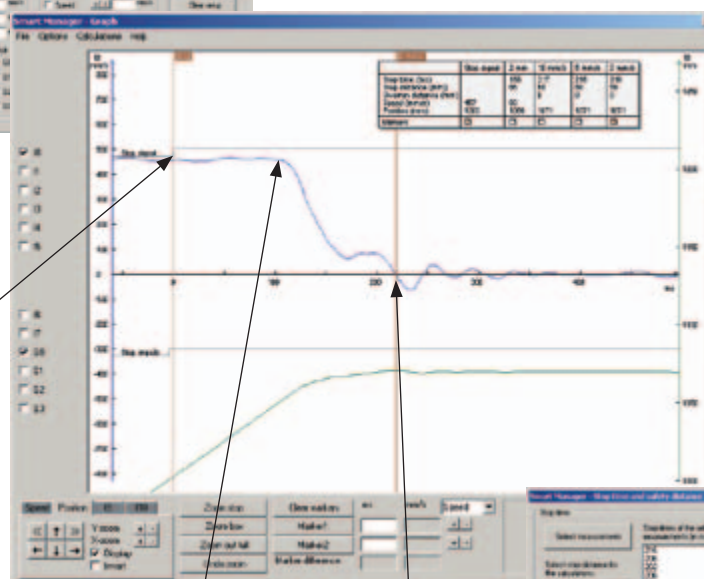

- Stop time data
- Zoom control
- Own cursors

Measured result

Relay contacts drop out

Machine stopped

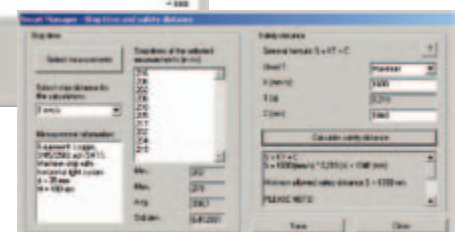

## Calculations

- Min., max. and average value and standard deviation from a series of measurements
- Protective distance can be calculated

## System requirements

Windows XP/2000/Me/NT  
100 MB free disk space





### Saving

- Select measurement series
- State extra information, e.g. the conditions and special circumstances for the measurements.

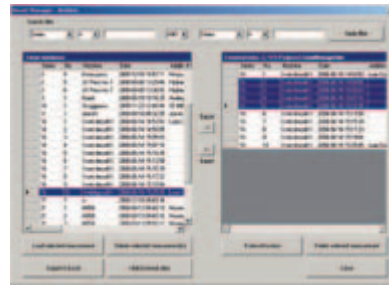

### Archiving

- Search filter
- Saved measurements
- Exported measurements

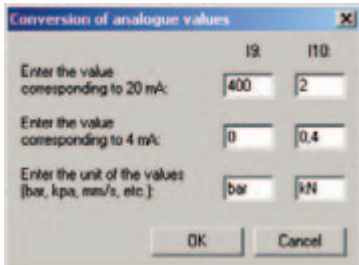

### Conversion of analogue signals

Smart can measure and show graphs for two different analogue sensors at the same time, with its inputs for 0/4-20 mA. Conversion of the measured current values can be done automatically by setting minimum and maximum values and the units for the inputs. In this way, for example, the results from an analogue pressure sensor can be shown and calculated as 0-400 bar instead of 4-20 mA, or an analogue load cell as 0-2 kN. This also means that if it is desired for the system to be triggered at a certain force, that force can be defined instead of needing to calculate the equivalent current value.

### Printout

Printing out is one of the most important functions of the program. Here is shown all the vital information about the measurements that is needed for such items as annual checking or providing the basis for CE labelling of a machine. Since the entire measuring sequence is shown in graphical format, one can understand why the stopping time has a certain value and also, in some cases, see what needs to be done to minimise the stopping time. The graph also acts as a kind of "fingerprint" of the machine movements, which means that different measurements can be compared with each other to see how the stopping sequence varies from time to time, or from year to year. In this way the effects of e.g. worn brakes or the effect on the machine control system can be seen. In order to get a complete basis from a measurement it is also important to state what assumptions have been made and what conditions applied when deciding when and how the stop signal was given.

Among other things, the stop signal details the person measuring, the measuring equipment, the machinery, the calculations and the protective distance. The printout also has a replaceable company logo and a field for extra information.

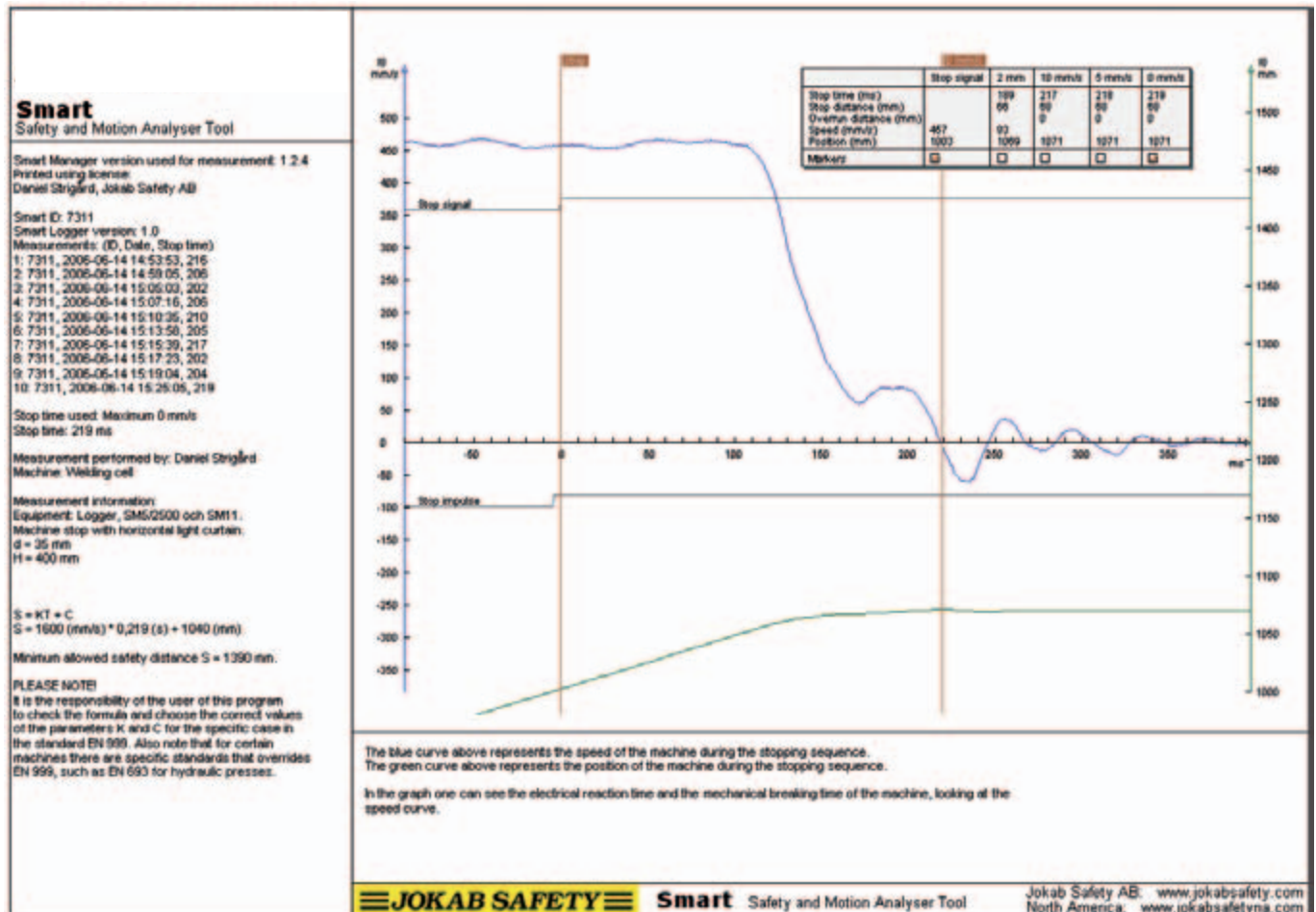

# Smart and accessories

## Smart Logger

The Smart Logger is the principal unit for data collection. The logger has a USB connection to the PC and 8 off M12 connections: one for the power supply to the I/O, one connection for an incremental sensor, two connections for analogue sensors and four connections for other I/O signals.

The Logger encapsulation is watertight, with M12 connections to prevent the entry of particles and fluids in the workshop environment. To prevent the Smart Logger from being damaged by incorrect currents and voltages from external equipment, all inputs and outputs, and external units, are electrically isolated from the processor in the Smart Logger by means of opto-couplers.

<b>Manufacturer:</b>	ABB AB/Jokab Safety, Sweden
<b>Article number/Ordering data:</b>	2TLA070300R0100 Smart Logger
<b>Dimensions:</b>	62 x 220 x 80 mm. (wxhxd)
<b>Weight:</b>	0.5 kg
<b>Protection class:</b>	IP 67
<b>Supply voltage:</b>	24 VDC
<b>Response speed:</b>	max 1 ms
<b>Positional accuracy:</b>	+/- 0.1 mm
<b>Digital I/O:</b>	8 inputs, 4 outputs (NPN OC)
<b>Analogue inputs:</b>	2 off, 0/4-20 mA
<b>Encoder:</b>	1 connection for a pulse sensor



## SM2 Button unit

The SM2 is used in conjunction with the Smart Logger for measuring with a manual stop impulse, without an electrical connection to the machine. When an SM2 is, for example, pressed against an emergency stop button to stop the machine, the SM2 sends a signal to the Smart Logger to start the measurement. An LED on the SM2 lights when the desired stop position is reached. The SM2 is connected to the Smart Logger by an M12 connection.

<b>Manufacturer:</b>	ABB AB/Jokab Safety, Sweden
<b>Article number/Ordering data:</b>	2TLA070300R0200 SM2 Button unit
<b>Dimensions:</b>	Size: 50 x 100 x 25 mm. (wxhxd)
<b>Weight:</b>	0.2 kg
<b>Application area:</b>	Two-handed control unit, Emergency stop, etc.
<b>Supply voltage:</b>	Fed from the Smart Logger



## SM3 Relay unit

The SM3 is used in conjunction with the Smart Logger for automatic stopping time measurements at the set position, or alternatively a manual stop pulse. When a stop signal comes from the Smart Logger a relay switches in the SM3. The SM3 then sends a signal to the Smart Logger to start measuring, and also activates the relay outputs to stop the machine. The relay in the SM3 is reset via the software when a new measurement is to be made. The SM3 is connected to the Smart Logger by an M12 connection.

<b>Manufacturer:</b>	ABB AB/Jokab Safety, Sweden
<b>Article number/Ordering data:</b>	2TLA070300R0300 SM3 Relay unit
<b>Dimensions:</b>	85 x 72 x 49 mm. (wxhxd)
<b>Weight:</b>	0.2 kg
<b>Application area:</b>	Electrical connection providing a stop pulse.
<b>Supply voltage:</b>	Fed from the Smart Logger
<b>Relay outputs:</b>	2 NO, 2 NC, 6A/250 VAC.
<b>Encoder:</b>	1 connection for a pulse sensor



## SM11 Flag unit

The Smart Logger is used in conjunction with the SM11 for automatic measurements of the stopping time and stopping distance. The unit is located in a light curtain with the flag parallel to the beam. When the flag is activated, the light beam/light curtain is interrupted, and the machine stops. The SM11 is connected to the Smart Logger by an M12 connection.

<b>Manufacturer:</b>	ABB AB/Jokab Safety, Sweden
<b>Article number/Ordering data:</b>	2TLA070300R1100 SM11 Flag unit
<b>Dimensions:</b>	145 x 85 x 37 (wxhxd). Shaft ø3 x 45 mm
<b>Weight:</b>	0.6 kg
<b>Application area:</b>	Light curtain, light beam
<b>Protection class:</b>	IP 40
<b>Batteries:</b>	10 rechargeable 1.2 V NiMH batteries. Total 12 V
<b>Power:</b>	Max 1200 mAh (approx. 200 operations).
<b>Temperature:</b>	0 to +45°C.
<b>Installation:</b>	On a table or a standard 1/4" camera tripod
<b>Charger:</b>	SM14



### SM5 1250/2500 Linear sensor

The SM5 is an incremental pulse sensor for connection to a Smart Logger. The sensor is protected by a robust enclosure. The sensor and end of the cable are secured to the machine by powerful magnets. The SM5 is connected to the Smart Logger by an M12 connection.

<b>Manufacturer:</b>	ABB AB/Jokab Safety, Sweden
<b>Article number/Ordering data:</b> SM5/1250: SM5/2500:	2TLA070300R0400 Linear sensor 2TLA070300R0500 Linear sensor
<b>Dimensions:</b>	SM5/1250: 106 x 88 x 100 mm (wxhxd) SM5/2500: 114 x 125 x 116 mm (wxhxd)
<b>Weight:</b>	SM5/1250: 1 kg SM5/2500: 1.4 kg
<b>Application area:</b>	Linear movement, e.g. press tools
<b>Supply voltage:</b>	Fed from the Smart Logger
<b>Max length:</b>	1250 or 2500 mm
<b>Max speed:</b>	5 m/s
<b>Resolution:</b>	0.1 mm



### SM7 Rotation sensor

The SM7 is an incremental sensor for connection to a Smart Logger. The sensor detects rotational movement via a wheel rolling against a shaft. The stand secures the sensor with the aid of just one knob. The stand itself is secured to the machine by a powerful magnetic foot. The SM7 is connected to the Smart Logger by an M12 connection.

<b>Manufacturer:</b>	ABB AB/Jokab Safety, Sweden
<b>Article number/Ordering data:</b>	2TLA070300R0700 SM7 Rotation sensor
<b>Dimensions:</b>	Sensor size: 46 x 40 x 59 (wxhxd) Stand size: Extended, approx. 400 x 50 x 90 (wxhxd)
<b>Weight:</b>	1.7 kg including stand
<b>Application area:</b>	Rotating motion, e.g. lathes, rollers
<b>Supply voltage:</b>	Fed from the Smart Logger
<b>Max speed:</b>	5 m/s
<b>Resolution:</b>	0.1 mm
<b>Wheel circumference:</b>	125 mm



### SM13 Battery pack

SM13 is a battery pack for the Smart Logger, which makes the Smart a completely mobile measuring tool. With the SM13 you don't need to connect the Logger to a wall socket for power, and can easily move it from one machine to another when you are measuring. Since the SM13 battery pack is the same physical size as the SM11 flag unit, it fits snugly into the SM9 carrying case. The charger for the SM13 is called the SM14 and provides a charging time of about 3 hours 15 minutes (2100 mAh). The SM14 also acts as a fast charger for the SM11.

<b>Manufacturer:</b>	ABB AB/Jokab Safety, Sweden
<b>Article number/Ordering data:</b>	2TLA070300R2300 SM13 Battery pack
<b>Dimensions:</b>	145 x 85 x 37 mm (LxWxH)
<b>Weight:</b>	0.8 kg
<b>Protection class:</b>	IP 40
<b>Connector:</b>	Negative pole at the centre of the charging connector
<b>Current rating:</b>	Maximum 0.9A
<b>Power:</b>	2100 mAh. With normal use lasts about 10-12 hours. (Higher capacity on request.)
<b>Batteries</b>	20 rechargeable 1.2 V NiMH batteries of size AA(R06). Total 24 V



### SM9 Carrying case

The SM9 is a practical carrying case with pockets to suit the various Smart units. Part of the protective foam insert in the lid of the case can be removed to make room for a laptop computer, so that all the equipment required can be carried in a single case.

<b>Manufacturer:</b>	ABB AB/Jokab Safety, Sweden
<b>Article number/Ordering data:</b>	2TLA070300R0900 SM9 Carrying case
<b>Dimensions:</b>	535 x 155 x 430 mm (LxWxH)
<b>Weight:</b>	3.5 kg



### Other accessories

Name	Article number	Description
SM6	2TLA070300R0600	AC/DC converter for Smart
SM14	2TLA070300R2400	Charger for flag unit SM11 and battery pack SM13.
USB cable	2TLA070300R1500	USB cable for communication with computer
Extension cables	2TLA020056R2000, 2TLA020056R2100, 2TLA020056R2200, 2TLA020056R2300 and 2TLA020056R2400	ABB Jokab Safety's extension cables with 5 conductors ideal for all Smart accessories



# Sensors/switches/locks



<b>Contents</b>	<b>Page</b>
<i>Why should you use sensors/switches?</i> _____	<b>9:2</b>
<i>How safe is a switch/sensor?</i> _____	<b>9:3</b>
<i>Non-contact safety sensor Eden</i> _____	<b>9:4</b>
<i>Safety Interlock switch JSNY5</i> _____	<b>9:8</b>
<i>Magnetic Switch JSNY7</i> _____	<b>9:10</b>
<i>Safety Interlock Switch JSNY8</i> _____	<b>9:12</b>
<i>Safety Interlock Switch JSNY9</i> _____	<b>9:14</b>
<i>Magnetic lock Magne</i> _____	<b>9:16</b>
<i>Process lock Dalton</i> _____	<b>9:22</b>
<i>Safety lock Knox</i> _____	<b>9:28</b>

Descriptions and examples in this book show how the products work and can be used. This does not mean that they can meet the requirements for all types of machines and processes. The purchaser/user is responsible for ensuring that the product is installed and used in accordance with the applicable regulations and standards. We reserve the right to make changes in products and product sheets without previous notice. For the latest updates, refer to [www.abb.com/lowvoltage](http://www.abb.com/lowvoltage). 2011.

# Why should you use sensors/switches?

## - to supervise doors and hatches around dangerous machines!

Assurance that a machine stops when a door or a hatch is opened can be solved by using different types of switches and sensors which are monitored with a safety relay or a safety PLC. Switches and sensors are available both as non-contact (dynamic or magnetic) and various types of interlocking devices. Interlocking devices can be used when it is required, via a signal, to lock a gate during processes that cannot be stopped during certain operations. They are also used with machines that have a long stopping time to prevent someone from entering before the machine has stopped.



## - to ensure that a position is reached!

The sensor monitors that the robot is standing still in a monitored position when someone enters the robot's working area. The robot is then only stopped by the program. If the robot leaves the position the power will be cut directly. This is used when the robot does not stop safely without restarting problems.

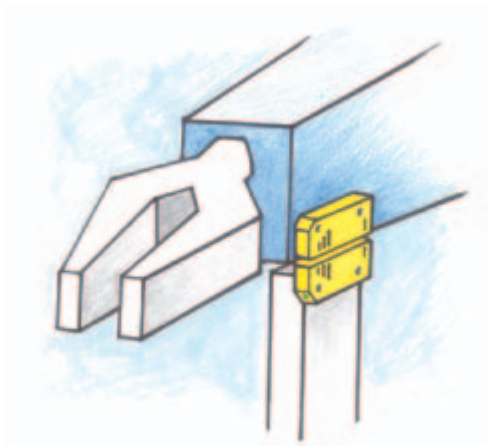

## - to manage the safety in harsh environments!

Non-contact dynamic sensors have a long lifetime because they are not physically mechanically operated. They also endure very harsh environments, e.g. cold, heat, high-pressure wash-down which is important in the food industry for example. Because the sensors are small, they are very easy to position and can even be completely concealed in doors and hatches.





## Eden - highest safety level and reliability

Our recommendation is to use the Eden sensor because it is the safest and most reliable solution. The Eden sensor is a non-contact switch and has a dynamic function. Also it is possible to connect up to 30 Eden sensors in series and still achieve PL e according to 13849-1.

### What requirements should one have on sensors/switches?

The sensor/switch shall be reliable from both the safety and production point of view.

- A person must be able to trust that dangerous movements and functions are safely stopped by the sensors/switches.
- From the production point of view unintentional stops should be avoided.
- Standard EN ISO 13 855 now includes requirements for safety distances for interlocked doors without locking function.

Safety level

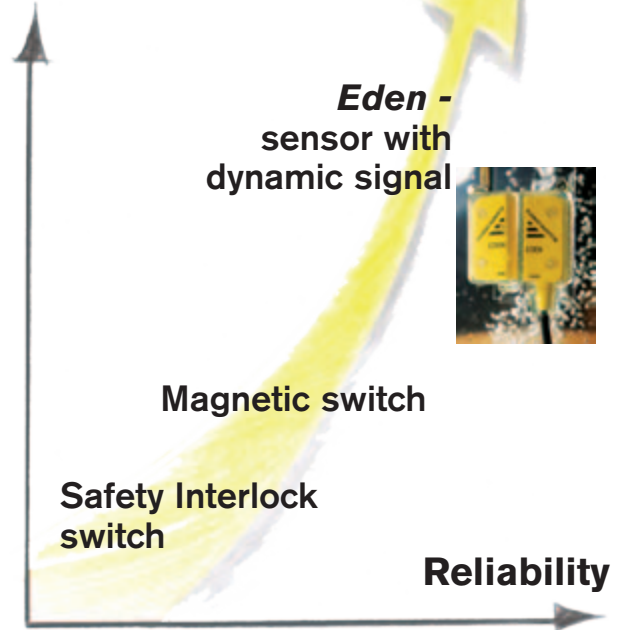

### How safe is a sensor/switch?

*In order to trust the safety function it is essential to be aware that a safety sensor/switch must be mounted and be used according to the specifications. The certification authorities only test the product according to the appropriate standards and to the specifications from the manufacturer.*

#### Mechanical switches

For mechanical switches, e.g. key operated, this means that a door or a hatch has to be constructed to small tolerances in order for the switch, the key or the mounting brackets to last according to the life time specification from the supplier. The screws holding the parts have to be locked in such a way that they cannot be loosened. In order to prevent material from getting into the slot for the key the environment has to be clean. If a door goes outside the design tolerances from wear, the screws loosen or material comes into the slot, this may lead to the interlocked switch not giving a stop signal when the door is opened. Even two mechanical switches on a door could fail to an unsafe state if the door somehow gets outside the tolerances of the switches. To prevent accidents the mechanical switch normally needs continuous checks of both the switch and the installation.

#### Non-contact sensors/switches

For non contact sensors the risks associated with mechanical switches (see above) do not exist. If screws, brackets or sensors get loose, it will lead to a stop signal. Therefore only one sensor with dual or dynamic function is needed in

order to reach the highest safety level. There are two types of non-contact sensors - active and passive. The active sensor, Eden, is constantly communicating via a dynamic signal between the two parts and any failure will directly lead to a stop signal. The passive type, a magnet switch, has two reed contacts which are activated by a coded magnet. Both the passive and the active sensors are checked every time a door is opened. From a safety point of view the active sensor, Eden, is to be preferred because it is checked constantly whereas the passive sensor is only checked when a door opens.

From the reliability point of view a long detection distance with large tolerances and a well defined on and off position is needed. The active sensor, Eden, fulfils these demands. A magnet switch has smaller tolerances and an intermediate position where only one contact opens. A bad installation or vibrations can lead to an unintentional stop if one contact opens and closes again. The supervision of a two channel system is based on both contacts having to be operated in order to permit a new start. In a dynamic safety circuit there is only one pulsed signal and therefore no intermediate position.

## Non-contact safety sensor

# Eden

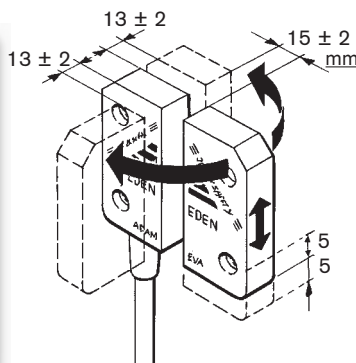

*Flexible mounting and  
The ability to operate at  
long distances.*

### Approvals:



### Safety sensor for:

- Doors and hatches
- Position control
- Sector detection
- Slot detection

### Features:

- Cat. 4/PL e according to EN ISO 13849-1 together with Vital or Pluto
- Non-contact detection, large sensing distance 0 - 15 mm ± 2 mm
- Up to 30 sensors in series with the highest level of safety PL e
- Versatile mounting, 360° detection
- Protection class IP 67/IP69.
- The dynamic signal passes through wood and plastic (not metal)
- Status information with LED on the sensor and in the cable connection.
- Small hysteresis (< 1mm)

### A non-contact safety sensor for the highest safety level

Eden - Adam and Eva is a non-contact safety sensor for use on interlocked gates, hatches etc. A coded signal is transmitted from the control device Vital or from the safety PLC Pluto via Adam to Eva which modifies the signal and sends it back again. The maximum sensing distance between Adam and Eva is currently 15 mm ± 2 mm.

Up to 30 Edens can be connected in series to Vital and still achieve the same safety level in the safety circuit. It is also possible to connect safety light beams and E-stops in the same safety circuit.

Adam is available with cable lengths up to 10 m and with M12 connectors. The LED on Adam provides indication of three different conditions, contact/non-contact between Adam and Eva and safety status. The same information is also available via the Adam connection cable. Eden E is available for harsh environments, as are Adam E and Eva E. Rapid blinking serves as an alignment aid. There are also coded versions, Eden C, Eden EC, Adam EC and Eva EC.

## Application examples - Eden

### Eden to detect position

Adam and Eva has contact only if they are within 15 mm from each other.

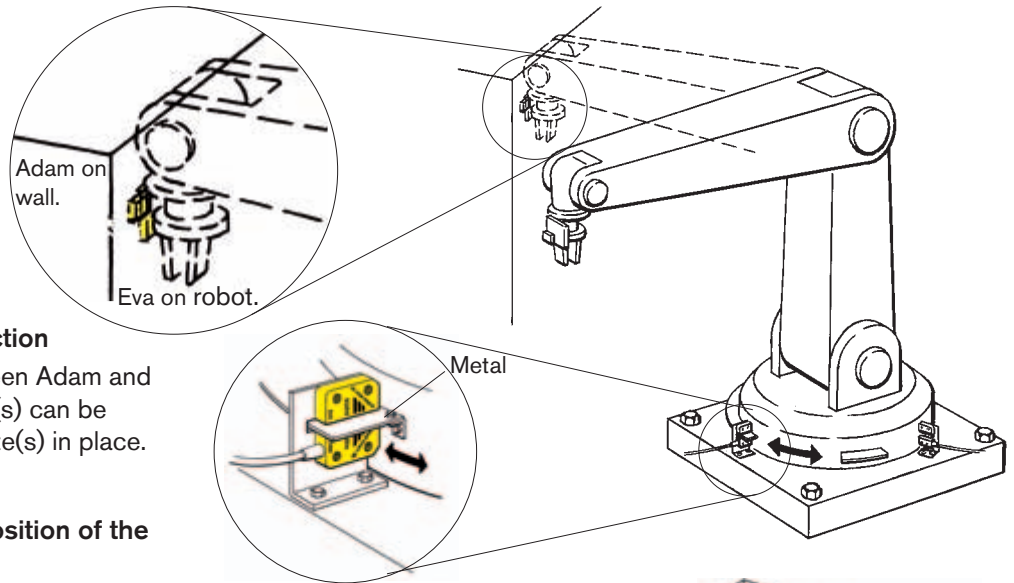

### Eden used for sector detection

Metal stops the signal between Adam and Eva. Additional Eden sensor(s) can be mounted to detect metal plate(s) in place.

### Eden used to detect the position of the saw guard.

Wood, plastic and other non-metallic materials let the signal pass between Adam and Eva.

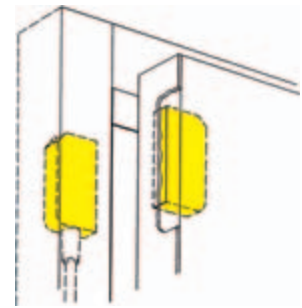
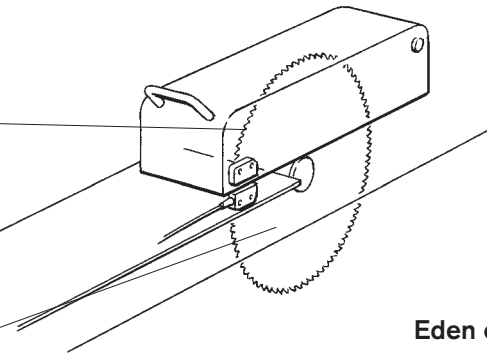
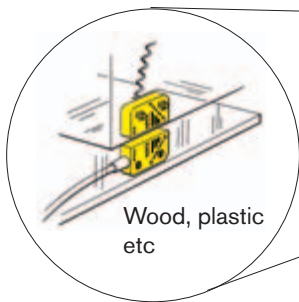

### Eden can be hidden in doors and hatches

Non-metallic door material between Adam and Eva allows the signal through

## Mounting – Eden

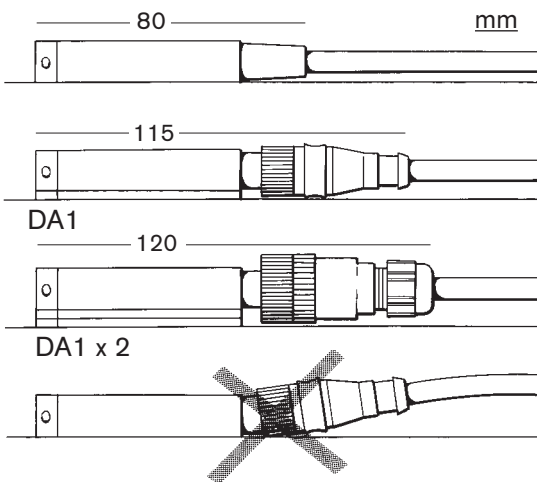

Mounting Adam with integral cable.

Mounting with one protection plate (DA1) for Adam M12 using prewired moulded M12 connector. For M12 connection, a straight contact is recommended.

Mounting with two protection plates (DA1) for Adam M12 using M12 connector with glanded cable.

Wrong mounting without protection plate may cause permanent damage to sensor.

### Notes:

Four protection plates are supplied with Adam M12. To protect Adam and Eva protection plate (DA1) can be used on both sides.

### DA2 mounting

The DA2 mounting spacer **must be** used in order to physically protect Eden from damage. Four spacers are provided with each Adam and Eva.

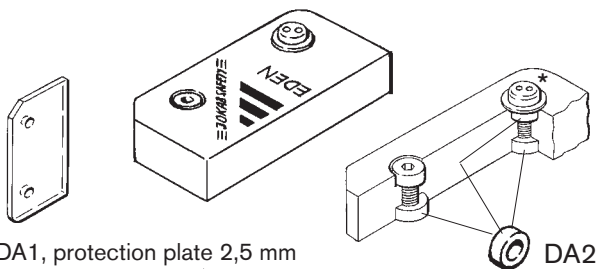

DA1, protection plate 2,5 mm

\* Safety screw

# Connection of Eden to Pluto

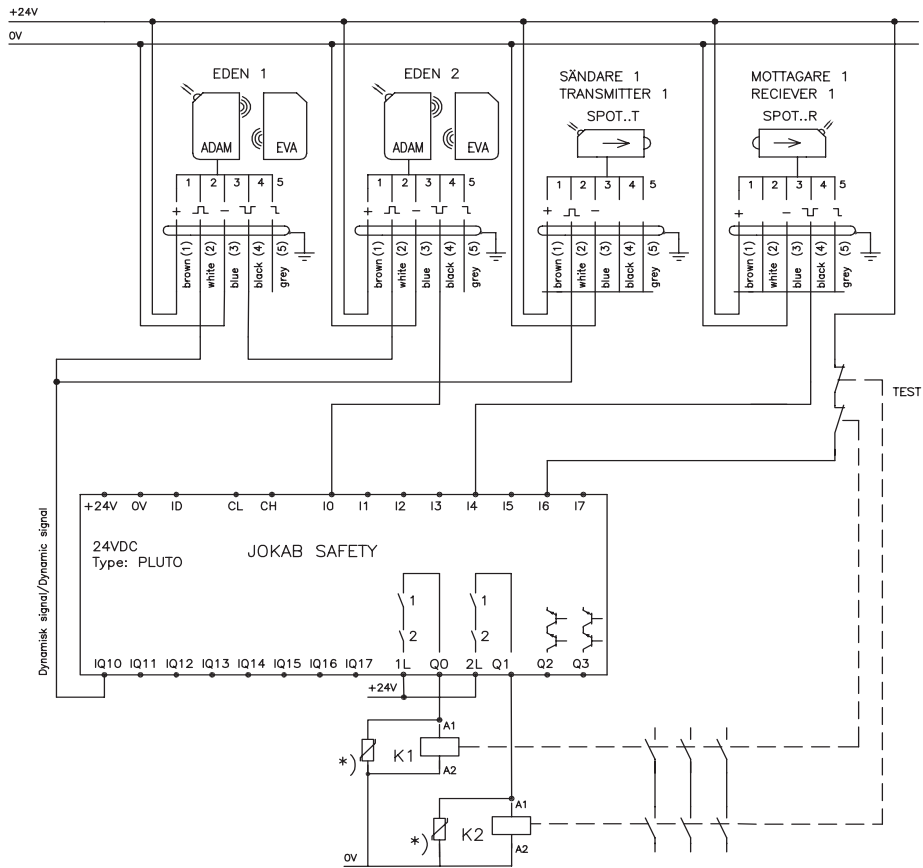

\*)OBS: Använd alltid transient skydd t.ex. VDR!  
 \*)NOTE: Always use transient suppressors, e.g. VDR's!

# Connection of Eden to Vital 1

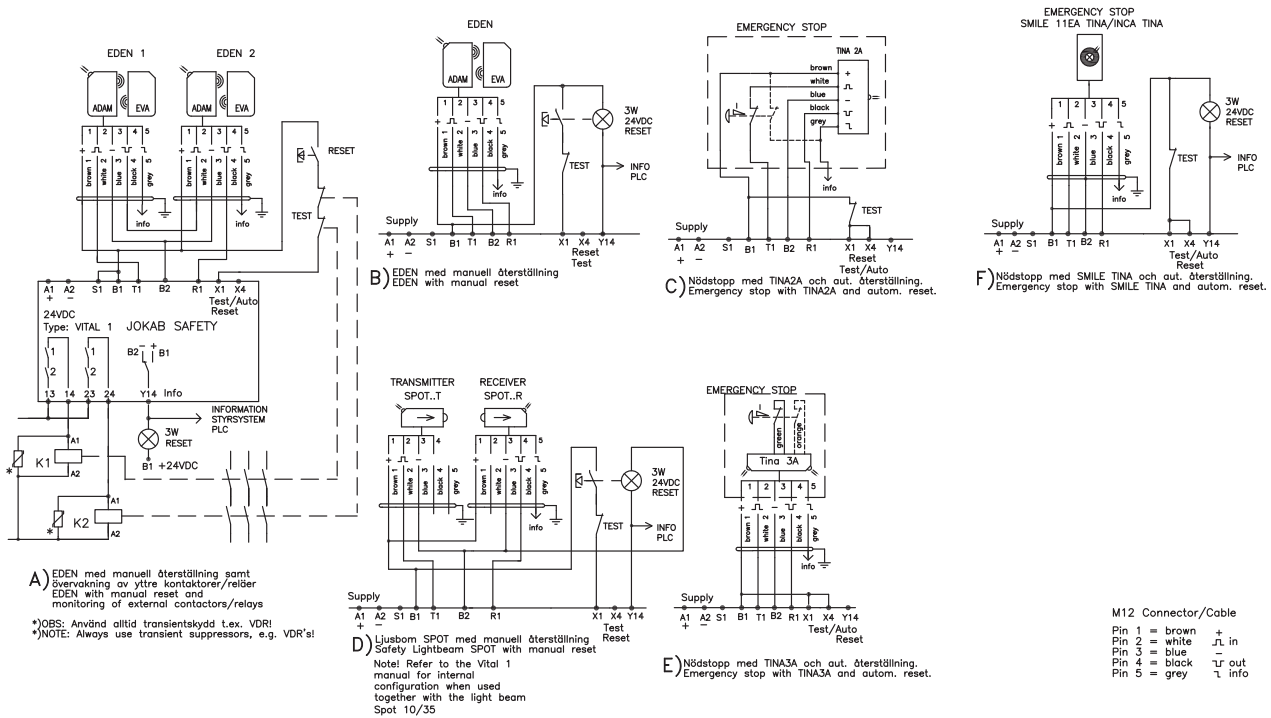

M12 Connector/Cable  
 Pin 1 = brown +  
 Pin 2 = white -  
 Pin 3 = blue -  
 Pin 4 = black -  
 Pin 5 = grey -

Technical data – Eden	
<b>Manufacturer</b>	ABB AB/Jokab Safety, Sweden
<b>Article number/Ordering data:</b>	
Eva*	2TLA020046R0000
Eva E*	2TLA020046R0600
Adam M12*	2TLA020051R0000
Adam 3 m*	2TLA020051R0200
Adam 10 m*	2TLA020051R0400
Adam 20 m	2TLA020051R0500
Adam E 10 m	2TLA020051R0600
Adam E 0,5 M12*	2TLA020051R0700
Adam E 20 m	2TLA020051R0800
* also available in grey	
<b>Safety level</b>	
IEC/EN 61508-1...7	SIL3
EN 62061	SIL3
EN ISO 13849-1	kat. 4/PL e
<b>PFH<sub>D</sub></b>	4,50 × 10 <sup>-9</sup>
<b>Colour</b>	Yellow and black
<b>Weight</b>	Eva: 26 g Eva E: 36 g Adam M12: 30 g Adam 3 m: 220 g incl. cable Adam 10 m: 650 g incl. cable Adam E10 m: 660 g incl. cable Adam EC 10 m: 660 g incl. cable Adam E 0,5 m + M12: 100 g incl. cable
<b>Power supply</b>	24VDC +15%-25%
<b>Power consumption</b>	Adam: without info output 45 mA with info output max 55 mA
<b>Max cable length</b>	see Vital technical data
<b>Ambient temperature</b>	
Eden/Eden C	-40°C ... +70°C (operation) -25°C ... +70°C (stock)
Eden E/EC	-40°C ... +70°C (operation) (Test ok +90°C ... +100°C) -25°C ... +70°C (stock)
<b>Protection class</b>	
Eden	IP67
Eden E	IP69K
<b>Mounting</b>	Installation Eden M4 screw, e.g. safety screw 20-053-42. Max. torque 2 Nm. Screw to be locked with Loctite or similar.  Installation Eden E M4 screw, e.g. safety screw 20-053-42. Max. torque 2 Nm. Screw to be locked with Loctite or similar.
<b>Detection distance max</b>	
Adam/Eva 15 ± 2 mm	Flash 2 mm before red position.
Adam E/Eva E 12 ± 2 mm	Flash 2 mm before red position.
Hysteresis approx. 1 mm	
Metal may have influence on detection distance. This can be prevented by protection plates, DA1.	
<b>Minimum distance to metal when there is metal on one or more sides.</b>	
	One More
Adam/Eva	0 mm 2,5 mm
Adam E/Eva E	0 mm 0 mm
<b>Minimum distance between Eden pairs</b>	50 mm
<b>Life</b>	>10 <sup>7</sup> cycles

<b>Material</b>	Macromelt (Based on polyamid) Eden E for extreme surroundings.
<b>Chemical resistance</b>	
Macromelt:	Cutting oils, vegetable and animal oils, hydrogen peroxide, diluted acids and bases: good Alcohol and strong acids: not recommended
PU (EdenE):	Cutting oils, vegetable and animal oils, hydrogen peroxide, diluted acids and bases, alcohols: good Strong oxidating acids: not recommended
<b>LED on Adam</b>	
Green:	Eva within range, safety circuit closed (door closed)
Flashing:	Eva within range, earlier safety circuit open (door closed)
Red:	Eva out of range, safety circuit open (door open)
Fast flashing:	Eva is within 2 mm from maximum sensing distance (door closed)
<b>Cable</b>	3 or 10 m, ø 5.7mm, black, PVC 5 x 0.34mm <sup>2</sup> + screen, UL 2464
<b>Connector</b>	M12: 5-pin male contact
<b>Connections</b>	
Brown (1)	+24 VDC
White (2)	Dynamic signal in
Blue (3)	0 VDC
Black (4)	Dynamic signal out
Grey (5)	Info output, see below
24 VDC when LED is green or flashing (tolerance -2 VDC), 10 mA max 0 VDC when LED is red. (tolerance +2 VDC)	
<b>Warning:</b> Incorrect connection may cause permanent damage to Adam devices.	
<b>Conformity</b>	2006/42/EG EN ISO 12100 1/2, EN 954-1, EN 60204-1, EN ISO 13849-1, EN 1088, GS-ET 15
<b>Certifications</b>	TÜV Nord <b>CE</b>

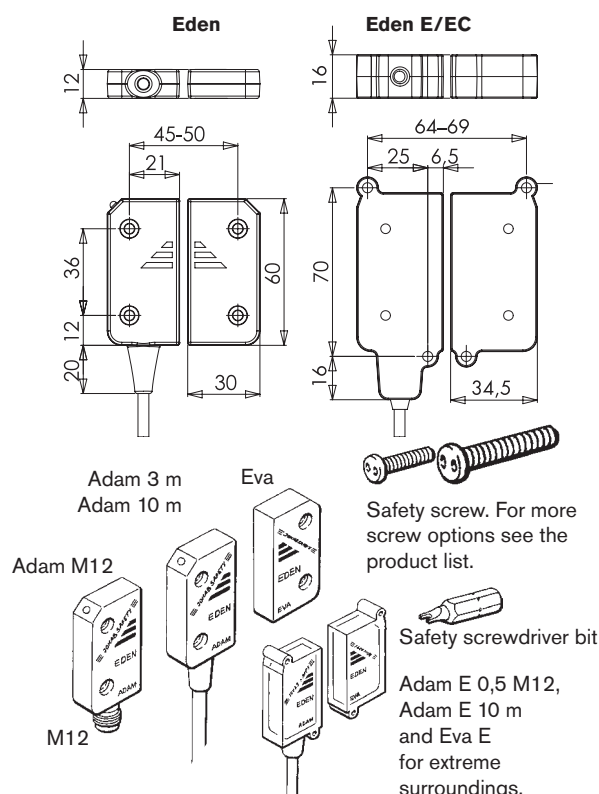



# Safety Interlock switch

# JSNY5

## Approvals:



## Application:

Gates  
Hatches

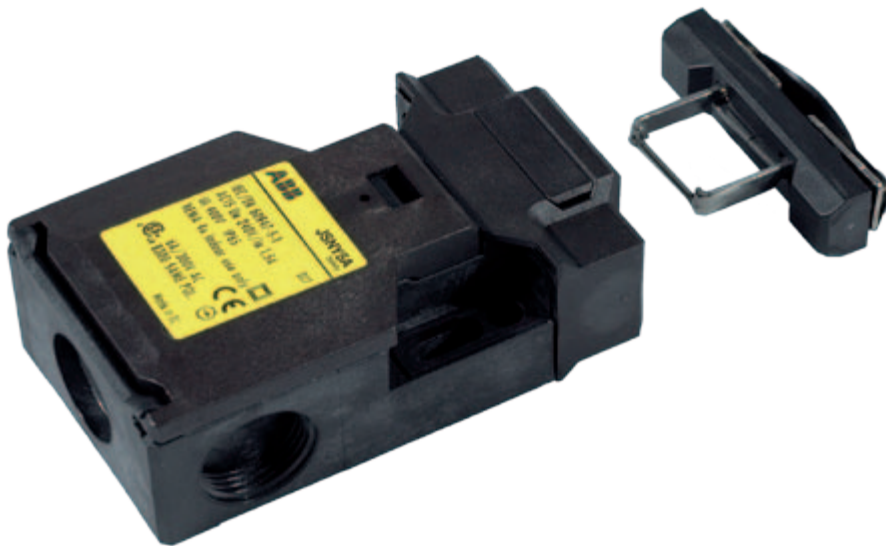

## Features:

2 NC + 1 NO (actuator in)  
4 actuating positions  
Actuator holding force 10 or  
30 N

### Switch operational description

JSNY5 offers three contacts which gives both the two contacts needed for high safety level as well as a contact for the indication of operating status.

The advanced design offers the choice of four operating positions from only two actuator entries by simply rotating the head through 180°.

However, when installed and in its working condition only one entry can be used, ensuring no other element can tamper with the switch function.

When mounting the switch from the front two elongated holes are provided to aid alignment with two set screw holes for accurate fixing. Top fixing is also possible.

Three cable entries allow for a variety of cabling options including through wiring.

### Positive forced disconnected contacts

The design assures that the contacts will not fail or be held in a normally closed position, due to failure of the spring mechanism or the welding/sticking of the contacts.

### Protection from unauthorised or incidental access

To avoid unauthorised operation the JSNY5 switch is manufactured using multicoding to GS-ET 15. The switch cannot be defeated by screwdrivers, magnets or any other mechanism.

### Safety level

The positive forced disconnect contacts gives a high safety level. By combining the JSNY 5 with one of our suitable safety

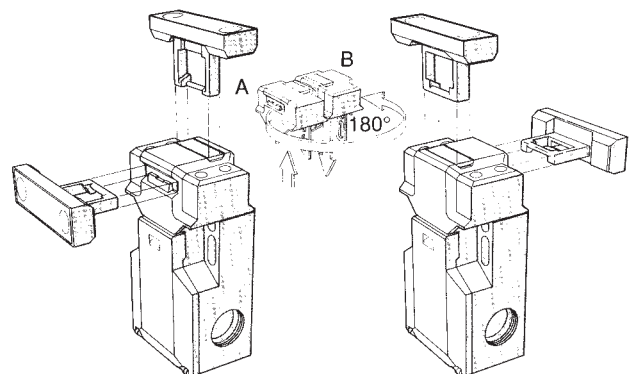

After opening the snap-on cover, the head portion can be removed (version A), after turning the head through 180° (version B) it can be replaced onto the body of the switch and be locked into position by closing the snap-on cover. This ensures 4 actuating positions are possible.

relays as for example from the RT-series, the safety PLC Pluto or Vital (Tina) the requirements for both hatch and gate switch supervision can be fulfilled. To obtain the same level of safety as Eden, two switches per gate are required.

### Regulations and Standards

The JSNY5 is designed and approved in accordance with appropriate directives and standards. See technical data



Technical data – JSNY5	
<b>Manufacturer</b>	ABB AB/Jokab Safety, Sweden
<b>Article number/ Ordering data:</b> JSNY5A holding force 10 N JSNY5B holding force 30 N	2TLA020022R0000 2TLA020022R0100
<b>Colour</b>	Black and yellow label
<b>Enclosure/Cover</b>	PA 6 (UL94-VO)
<b>Actuator</b>	Steel
<b>Min. opening radius for actuator on a hatch</b>	150 mm
<b>Ambient operating temperature</b>	-30°C to +80°C
<b>Contacts (actuator key inserted)</b>	2 NC + 1NO (NC are direct opening action)
<b>Mechanical life</b>	1 Million switch operations
<b>Max switching frequency</b>	30/min
<b>Fixing</b>	body 2 x M5, actuator 2 x M5
<b>Cable entry</b>	2 x M20 x 1,5
<b>Weight</b>	approx. 0.13 kg
<b>Degree of protection</b>	IP65 IEC 60529 / DIN VDE 0470 T1

<b>Rated insulation voltage</b>	400 V AC
<b>Rated operational current</b>	5A
<b>Utilisation category</b>	AC-15/DC-13
<b>Short-circuit protection</b>	Fuse 6A Slow acting, 16A quick acting
<b>CSA</b>	5A 300V AC B300 (same polarity)
<b>B<sub>10d</sub></b>	JSNY 5A: 2,00×10 <sup>6</sup> JSNY 5B: 2,00×10 <sup>6</sup>
<b>Conformity</b>	2006/42/EG EN ISO 12100 1/2, EN 954-1, EN 60204-1, EN ISO 13849-1, EN 1088, GS-ET 15

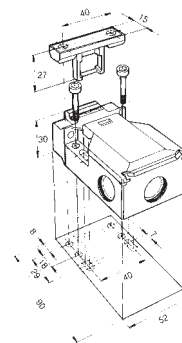

## Assembly - JSNY5

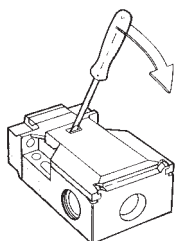

### Easy accessibility for wiring

The snap-on cover is released by a screwdriver and can be opened to an angle of 135° providing easy access to the wiring terminals. Should the snap-on cover not provide adequate security, a retaining screw can be used.

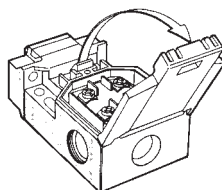

### Protected contact block

A transparent cover protects the contact block from external elements during the installation and wiring process.

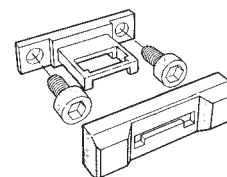

### Prevention of actuator dismantling

A cover plate with a one-way snap-fit which seals the mounting screws prevents unauthorised dismantling of the actuator assembly. The cover plate **must** be mounted to prevent overtravel of the switching mechanism.

## Contact Description - JSNY5

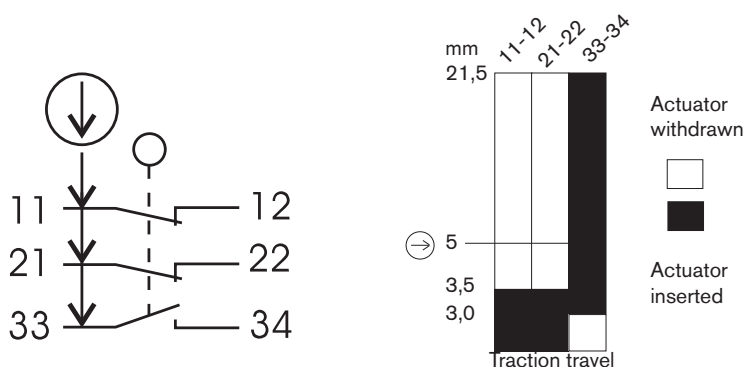

### Overlapping contact 33 - 34.

The overlapping contact 33 -34 enables operational status indication of eg. incorrect adjustment of switch before the positive forced disconnect NC contacts open.

### Note!

The switch must not be used as an end stop!

## Accessories and spare parts

- Standard actuator
- Flexible key for smaller opening radius
- Cable gland
- Snap-on cover
- Tina 2A with M20 connection for a dynamic loop
- Tina 2B with cable connection
- Tina 3A with M12 and M20 connections for a dynamic loop

# Magnetic Switch

# JSNY7



## Approvals:



## Application:

Gates  
Hatches  
Position control

## Features

Small size  
IP 67

### Switch operation description

The magnetic switch is designed to operate in dirty industrial environments and is certified to the highest level of safety regulation when working together with a suitable ABB Jokab Safety safety relay or Safety-PLC Pluto. The magnetic switch is small and resistant to both dirt and water, and has no dust collecting cavities making it useful in environments where hygiene is paramount. The small size of the switch makes it easy to position and hide on gates and hatches.

The magnetic switch has a long working life since no mechanical contact is made during operation.

### Contacts

The magnetic switch has one closing and one opening contact. Both contacts have to be monitored. The contacts may be monitored by either the RT9 safety relay or other suitable relays in the new RT-series, i.e. RT6, RT9 or Safety PLC Pluto.

### Protection from unauthorised or incidental access

To avoid unauthorised operation of the JSNY7 switch it is only possible to actuate the JSNY7R with the coded magnet, JSNY7M. Other magnets, screwdrivers and tools have no effect on the switch contacts.

### Safety level

The JSNY7 is approved to the highest level of safety regulations, PL e according to EN ISO 13849-1 together with safety relay in the RT-series or Pluto PLC.

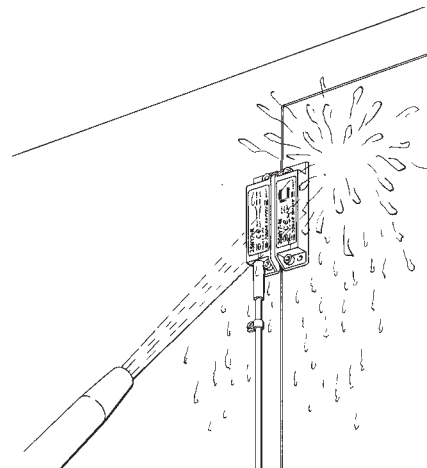

*JSNY7 is resistant to both dirt and water.*

### Regulations and Standards

The JSNY7 is designed and approved in accordance with appropriate directives and standards. See technical data.

Technical data – JSNY7	
<b>Manufacturer</b>	ABB AB/Jokab Safety, Sweden
<b>Article number/ordering data</b>	JSNY7R-3 Magnetic switch 3 m cable 2TLA020023R0000 JSNY7R-6 Magnetic switch 6 m cable 2TLA020023R0100 JSNY7R-10 Magnetic switch 10 m cable 2TLA020023R0200 JSNY7M Magnetic switch 2TLA020024R0000
<b>Colour</b>	Black
<b>Enclosure/Cover</b>	PA 6 (UL94-VO)
<b>Supply voltage max</b>	30 VDC
<b>Switch current max</b>	100 mA
<b>Max switching frequency</b>	1 Hz
<b>Mechanical life</b>	3 x 10 <sup>8</sup> switch operations, depending on load
<b>Operating temperature range</b>	-5°C to +70°C (moveable) -20°C to +70°C (fixed)
<b>Connection</b>	Cable ø4.5, 4x0.25 mm <sup>2</sup> , 3 meter ; PVC (other lengths upon request)
<b>Switching point</b>	Min. switch-on point 5 mm Max. switch-off point 14 mm
<b>Weight</b>	Coded magnet: 32 g Sensor with 3m cable: 133 g
<b>Protection class</b>	IP67

<b>B<sub>10d</sub></b>	JSNY 7R-3: 3,00×10 <sup>7</sup> JSNY 7R-6: 3,00×10 <sup>7</sup> JSNY 7R-10: 3,00×10 <sup>7</sup>
<b>Conformity</b>	2006/42/EG EN ISO 12100 1/2, EN 954-1, EN 60204-1, EN ISO 13849-1, EN 1088, GS-ET 15

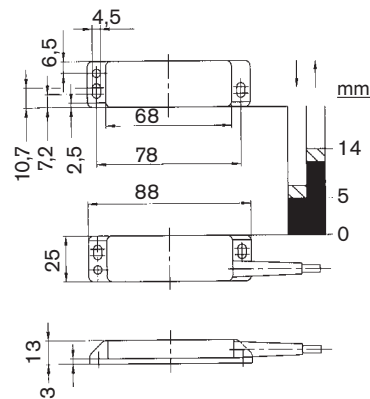

Electrical connection  
Two-channel switching, high safety level.

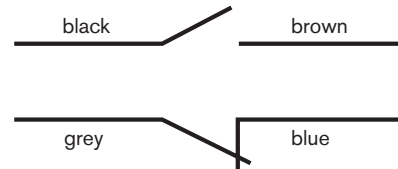

## Electrical connection description - JSNY7

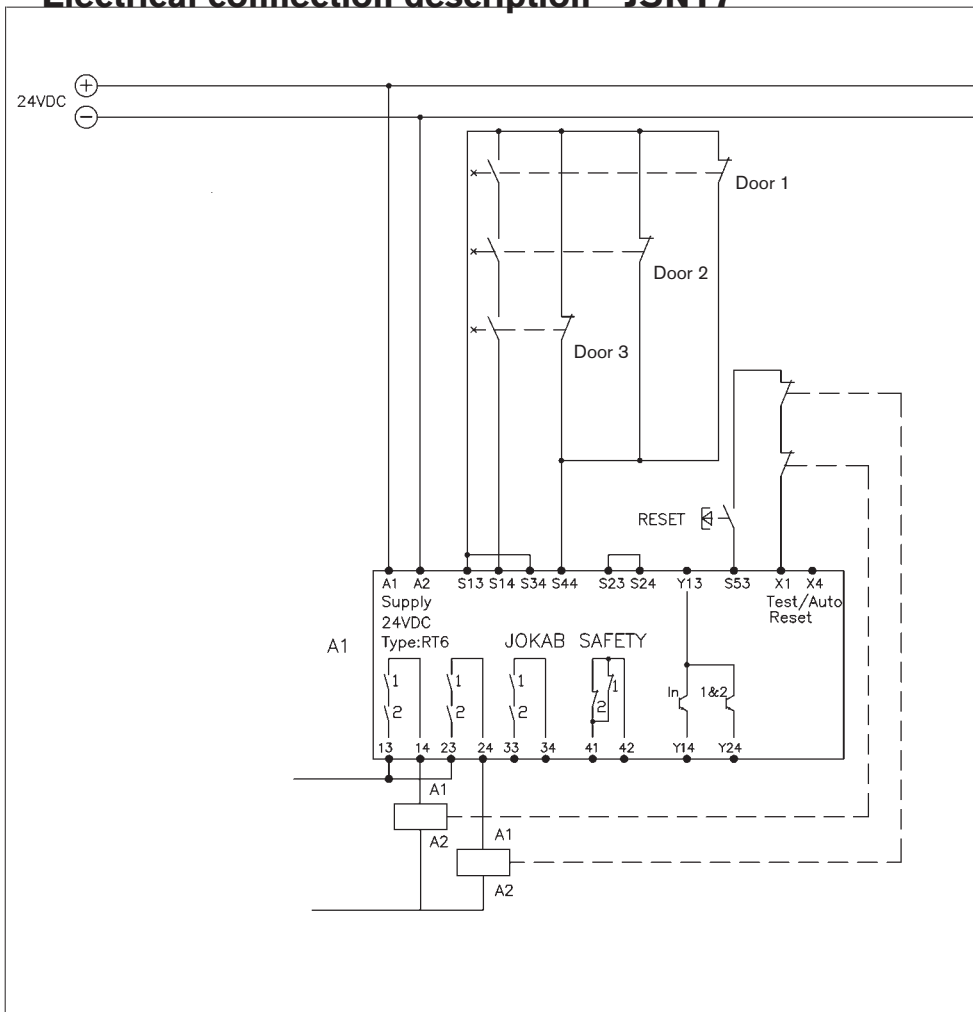

### Electrical Connection example

Three JSNY7 connected to RT6 safety relay.

#### NOTE!

Safety components drawn in released position.

#### NOTE!

This solution with 3 magnetic switches only complies with category 3 as per EN 954-1/EN ISO 13849-1.

To reach highest level of safety only one magnetic switch should be connected to the safety relay.

# Safety Interlock Switch

# JSNY8

## Approvals:



## Application:

Gates  
Hatches

## Features:

Robust design  
Universal installation  
2 NC + 2 NC outputs  
1000 N actuator holding force

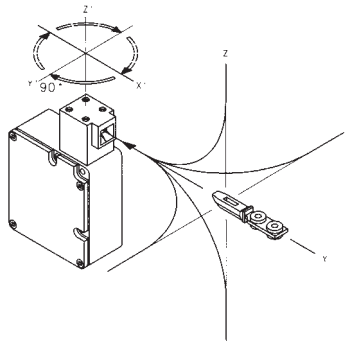

### Description

The JSNY8 Safety Interlock Switch, in conjunction with the machine control system, enables gates/movable guards etc to be locked in their protective positions, thus preventing access to machinery until dangerous operations have ceased.

Applications include:

- processes which cannot be interrupted, such as welding.
- machinery with a long stopping procedure, such as paper machinery that requires a long braking operation.
- prevention of unauthorised access to a particular area.

The JSNY8 has 2 NC + 2 NC positive force disconnection contacts. The first pair closes when the actuator key is pushed into the head. The other pair closes when the locking mechanism is in the locked position. The head can be set in four positions, thus providing the safety device with four different operating positions. These are selected by twisting the head as shown in the diagram above. The leading edges of the actuator key are reinforced and bevelled in order to guide it properly into the hole. The JSNY8 is encased in a robust metal housing (IP67) providing a high level of protection to the internal operating components.

### Two versions

The JSNY8 is available in two basic versions, either with a spring lock or a magnetic lock.

In the spring lock (JSNY8S) version, the locking mechanism moves into the locked position directly when the door is closed and the actuator key is pushed into the lock. The actuator key can only be released and the gate opened by supplying operational voltage to the solenoid (E1-E2).

The JSNY8S also has an emergency 'unlocking' facility to enable the actuator key to be released without the energisation of the solenoid (E1-E2).

In the magnetic lock (JSNY8M) version, the locking mechanism is only in the locked position when the solenoid (E1-E2) is supplied with operating voltage. Release of the actuator key is only possible when the operating voltage is removed from the solenoid (E1-E2).

### Optional features

The following optional features are available:

- actuator to operate at smaller radius.
- customer specific applications.

### Tamper-proof

The JSNY8 is tamper-proof. The safety device cannot be manipulated by screwdrivers, magnets or other tools.

### Safety level

The JSNY8 has double forced disconnection contacts to the actuator key and the locking mechanism. The actuator key has a triple coding design. To achieve maximum safety level in the connection to the machine's control system, it is recommended that the JSNY8 is monitored by an appropriate ABB Jokab Safety safety relay, Pluto safety-PLC or Vital. To obtain the same level of safety as Eden, two switches per gate are required.

### JSNY8S

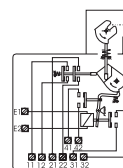

### JSNY8M

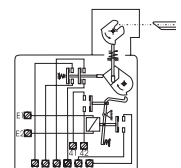

### Regulations and Standards

The JSNY8 is designed and approved in accordance with appropriate directives and standards. See technical data.

Technical data – JSNY8	
<b>Manufacturer</b>	ABB AB/Jokab Safety, Sweden
<b>Article number/Ordering data:</b> JSNY8M 24DC JSNY8S 24DC	2TLA020030R0000 2TLA020030R0100
<b>Colour</b>	Black
<b>Enclosure</b>	Metal housing
<b>Actuator key</b>	Steel & plastic (PA6)
<b>Min. operating radius for hatch</b>	400 mm (smaller radius on request)
<b>Actuator holding force</b>	1000 N
<b>Working temperature</b>	-30°C to +60°C
<b>Contacts</b> actuator key inserted locking mechanism, locked position	2 NC 2 NC
<b>Mechanical service life</b>	1 million switch operations
<b>Installation fixings</b>	3 x M5
<b>Cable entry</b>	2x M20 x 1.5
<b>Weight</b>	550 g
<b>Enclosure class</b>	IP67
<b>Operating voltage</b>	24V DC, 230 V AC
<b>Rated insulation voltage</b>	250V

<b>Rated operating current</b>	10A
<b>Utilisation category</b>	AC 12 250V/10A AC 15 230V/4A
<b>Short-circuit protection</b>	Fuse 10A slow-acting, 16A quick-acting
<b>Power consumption</b>	5.2 W
<b>B<sub>10d</sub></b>	JSNY 8M 24 VDC: 2,00×10 <sup>6</sup> JSNY 8M 230 VAC: 2,00×10 <sup>6</sup> JSNY 8S 24 VDC: 2,00×10 <sup>6</sup> JSNY 8S 230 VAC: 2,00×10 <sup>6</sup>
<b>Conformity</b>	2006/42/EG EN ISO 12100 1/2, EN 954-1, EN 60204-1, EN ISO 13849-1, EN 1088, GS-ET 19, EN 60947-5-1

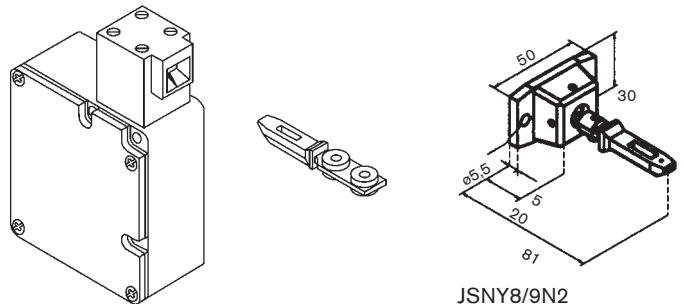

JSNY8/9N2  
Rmin: 150 mm  
Flexible actuator.

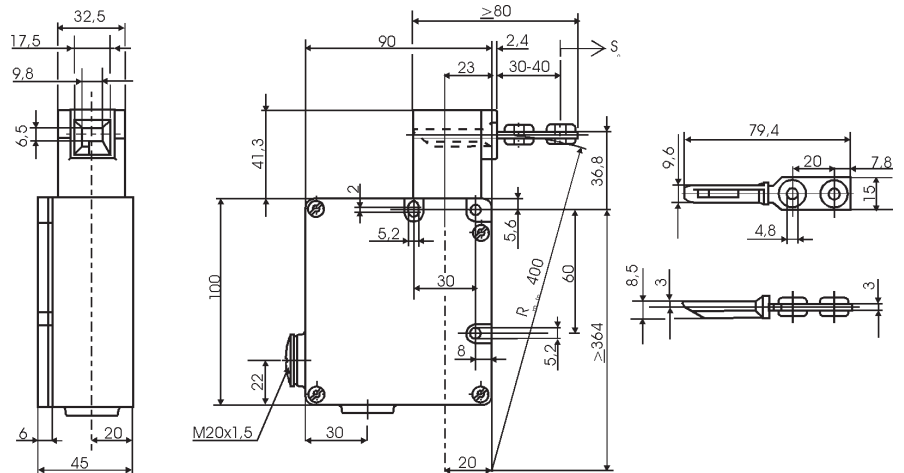

**Note:** Do not use switch as end stop!

## Contact description JSNY8S/M - JSNY8S/M

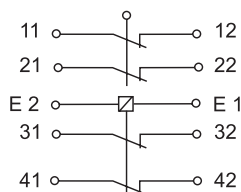

**JSNY8S**  
Key actuator inserted  
Normally locked  
(E1-E2 unpowered)

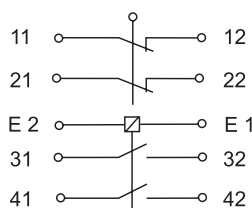

**JSNY8M**  
Key actuator inserted  
Normally unlocked  
(E1-E2 unpowered)

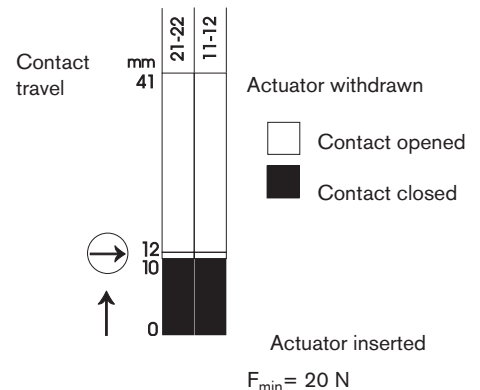

# Safety Interlock switch

# JSNY9

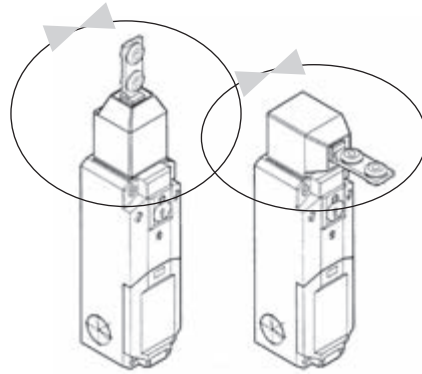

*The control unit offers eight operating positions that provide the actuator with eight different input options.*

## Approvals:



## Application:

Gates  
Hatches

## Features:

Compact and robust  
Universal installation  
2 X (1NO+1NC)  
Actuator holding force  
1500 N  
Eight head configurations  
LED status indication  
(optional)

### Description

The JSNY9 is used for locking a gate/hatch, to prevent access to machinery, until hazardous operations have ceased.

Applications include:

- processes which cannot be interrupted, e.g. welding.
- machinery with a long stopping time, e.g. paper machinery which requires a long braking operation.
- prevention of unauthorised access to a particular area.

The JSNY9 is equipped with a 2 x (1NO + 1 NC) contact configuration, the first pair of contacts changeover when the key is inserted. The second pair of contacts changeover when the locking mechanism is in the locked position.

The JSNY9 switch is encased in a robust plastic housing and can be mounted either horizontally or vertically. The advanced design of the head provides eight possible key insertion options, this is achieved by mounting the head either vertically or horizontally on the base unit, as shown in the diagram. The location for the actuator key is reinforced and bevelled to ensure a smooth operation.

### Two versions

The JSNY9 switch is available in two basic versions, either with a spring lock or an electro-magnetic locking mechanism.

The JSNY9S (spring lock) switch operates immediately when the gate/hatch is closed, i.e. when the key actuator is inserted into the locking mechanism. The gate/hatch can be opened and the actuator key released only by supplying the operational voltage to the solenoid connections (E1 E2). The JSNY9S also has a manual emergency unlocking facility to enable authorised release of the actuator key.

In the JSNY9M (magnetic lock) version, the mechanism is only locked when the gate/hatch is closed i.e. the actuator key inserted and the solenoid (E1 E2) supplied with the operating voltage. The gate/hatch can only be opened when this operating voltage is removed.

### Optional features

The following optional features are available:

- LED display, indicating the status of the actuator key, locking mechanism and contacts.
- Actuator to operate at smaller radii.
- Customer specific applications.

### Protection from unauthorised access

The JSNY9 is designed to protect against unauthorised access; screwdrivers, magnets or similar tools cannot operate the safety switch.

### Safety level

In order to achieve a high safety level, the JSNY9 switch is equipped with dual sets of contacts operated with a coded actuator key. In order to meet the required installation safety level it is recommended that the JSNY9 safety switch is monitored by an appropriate ABB Jokab Safety safety relay. To obtain the same level of safety as Eden, two switches per gate are required.

### Regulations and Standards

The JSNY9 is designed and approved in accordance with appropriate directives and standards. See technical data.



Technical data – JSNY9	
<b>Manufacturer</b>	ABB AB/Jokab Safety, Sweden
<b>Article number/Ordering data:</b> JSNY9S 24V AC/DC JSNY9M 24V AC/DC	2TLA020036R4400 2TLA020036R4500
<b>Colour</b>	Black
<b>Enclosure/Cover</b>	Polyamid PA6
<b>Actuator</b>	Steel & plastic (PA6)
<b>Min. key operating radius</b>	400 mm (smaller radius available on request)
<b>Actuator holding force</b>	1500 N
<b>Operating temperature</b>	- 25° C to + 70° C
<b>Contacts</b> actuator in Locking mechanism in locked position	1 NO + 1 NC 1 NO + 1 NC (NC are direct opening action)
<b>Mechanical life</b>	1 million switch operations
<b>Installation fixing</b>	4 x M5
<b>Cable entry</b>	3 x M20 x 1.5
<b>Weight</b>	approx. 300 g
<b>Enclosure Class</b>	IP67
<b>Operating voltage</b>	24 V AC/DC
<b>Isolation voltage</b>	250 V
<b>Thermal Current</b>	2.5 A

<b>Utilisation category</b>	AC 15 230V / 4A
<b>Short-circuit protection</b>	Fuse 6 A slow acting
<b>Power consumption</b>	1.1 VA (56 VA during 0.2s)
<b>B<sub>10d</sub></b>	JSNY 9M: 2,00E+06 JSNY 9S: 2,00E+06
<b>Conformity</b>	2006/42/EG EN ISO 12100 1/2, EN 954-1, EN 60204-1, EN ISO 13849-1, EN 1088, GS-ET 19, EN 60947-5-1

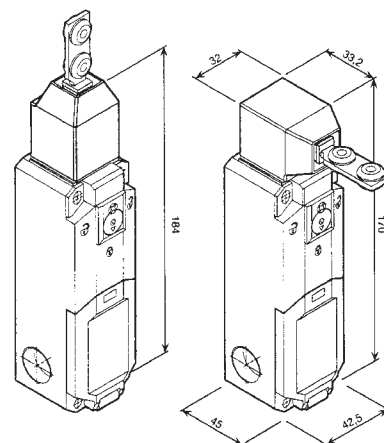

**NB.**  
The safety switch must not be used as an end stop!

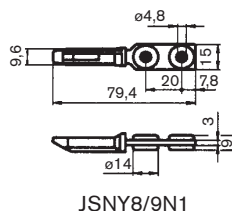
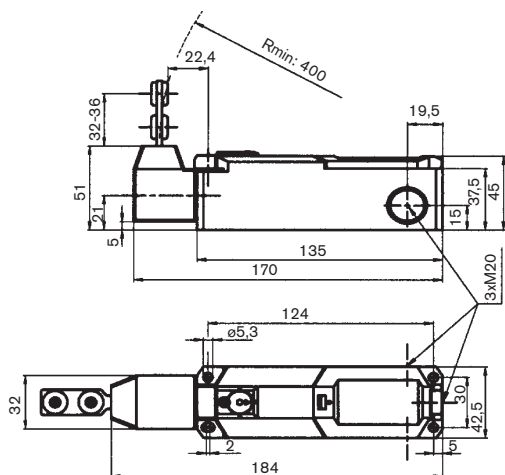

JSNY8/9N1

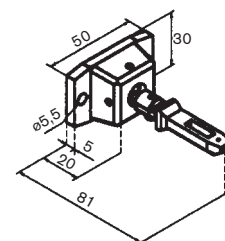

JSNY8/9N2  
Rmin: 150 mm

### Contact description - JSNY9 S/M

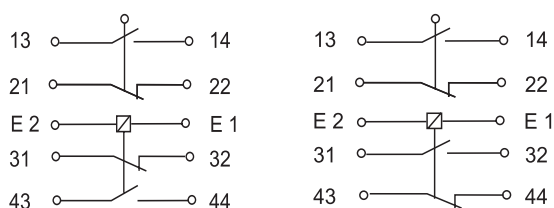

**JSNY9S**  
Actuator inserted  
Locked position  
(E1-E2 unpowered)

**JSNY9M**  
Actuator inserted  
Unlocked position  
(E1-E2 unpowered)

**JSNY9SLA/MLA**  
See separate data sheet  
for switches with LED  
indication.

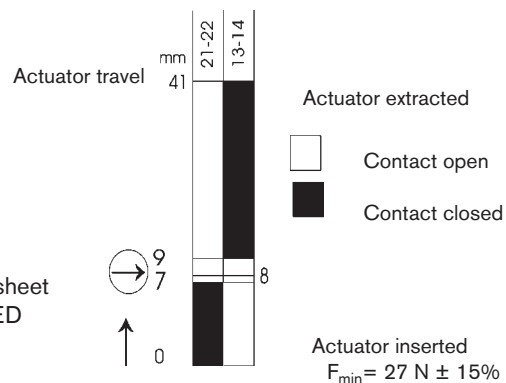

## Magnetic lock

# Magne

### Approval:

TÜV Nord 

### Application:

Electrical locking of doors and hatches to production applications that are sensitive to unintentional/unnecessary interruptions.

For safety supervision the Magne 2 has an integrated Eden.

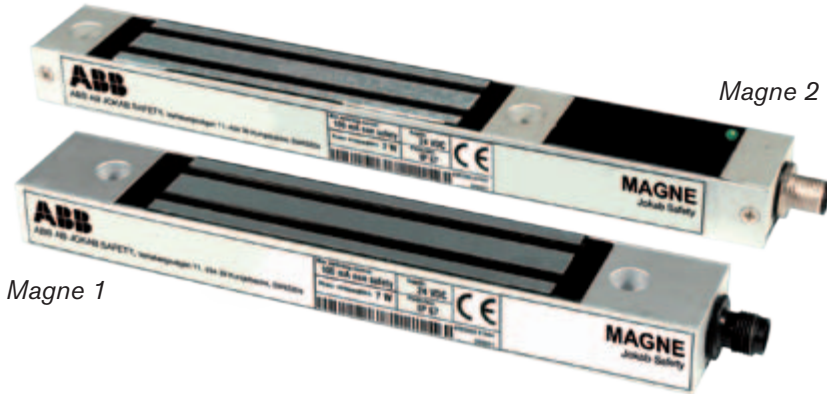

Magne 2

Magne 1

### Features:

No moving parts

Strong Magnetic holding force: 1500N

Can stand and operate in harsh environments

Locked/unlocked indication  
Possible to connect in series with Eden sensors

No current peaks on activation

Magne 2 in combination with a handle profile provides a complete door solution

### Magnetic lock with indication

Magne is a magnetic lock that is designed for industrial applications and that can withstand harsh environments. As it is designed with no moving parts, it is durable and long lasting. Magne, with its electro-magnet, keeps a door locked with a holding force up to 1,500 N and also magnetic material does not attach to the magnetic surface when the power is off.

Use of M12 connectors makes it easy to connect several Magne units and Eden sensors in series enabling control and monitoring by either a Pluto safety PLC or a Vital safety controller. Via the connection cable it is also possible to obtain an indication signal informing if the Magne unit is locked or not.

### Accessories:

- Mounting kit for conventional door, with fitting and screws for assembly on ABB Jokab Safety Quick-Guard fencing system (5-15 mm door gap)
- Plastic handle
- Handle profile for mounting on a hinged door with ABB Jokab Safety's Quick-Guard fencing system (5-15 mm door gap).



*Magne is easy to assemble, adjust and dismantle in and out of the T-slot of the Quick-Guard fencing system.*

## Models and accessories - Magne

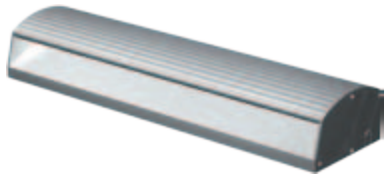

Handle profile that hides Magne completely when the door is closed.



Magne 1A with installation kit (JSM D21B) and handle (incl. screw) fitted on profile.



Magne 2A with installation kit (JSM D23) for sliding door fitted on profile.



Magne 2A with installation kit (JSM D21B, JSM D24) and handle (incl. screw) fitted on profile.

### Models and ordering data

<b>Magne 1A</b>	2TLA042022R0000	Process lock, Incl. anchor plate
<b>Magne 2A</b>	2TLA042022R1000	Process lock with built-in Eden, incl. anchor plate
<b>Magne 1B</b>	2TLA042022R0100	Process lock incl. anchor plate with built-in permanent magnet (30 N)
<b>Magne 2B</b>	2TLA042022R1200	Process lock incl. anchor plate with built-in Eden and built-in permanent magnet (30 N)
<b>Magne 2Ax</b>	2TLA042022R1300	Process lock with built-in Eden and 5-pin M12 connector for Urax, incl. anchor plate
<b>Magne 2Bx</b>	2TLA042022R1400	Process lock with built-in Eden and 5-pin M12 connector for Urax, incl. anchor plate with built-in permanent magnet (30 N)
<b>Accessories</b>		
<b>JSM D21B</b>	2TLA042023R0500	Assembly kit for anchor plate
	2TLA042023R0100	Handle profile for Magne
<b>JSM D23</b>	2TLA042023R0200	Fixture for sliding door
<b>JSM D24</b>	2TLA042023R0300	Assembly kit for Eva
	2TLA042023R0400	Anchor plate with permanent magnet
	2TLA042023R1000	Handle for JSM D21B

<b>Technical data – Magne</b>	
<b>Manufacturer</b>	ABB AB/Jokab Safety, Sweden
<b>Safety level</b> IEC/EN 61508-1...7 EN 62061 EN ISO 13849-1	SIL3 SIL3 Kat. 4/PL e
<b>PFH<sub>D</sub></b>	4,50×10 <sup>-9</sup>
<b>Power supply</b>	Magnet: 24 VDC + 15% -20% Eden: 17–27 VDC, ripple max 10%
<b>Power consumption</b>	Magnet: 7 W (300 mA at 24VDC) Eden: 45–55 mA (see data for Eden)
<b>Operating temp. range</b>	-20°C to +50°C
<b>Protection class</b>	IP67
<b>Weight</b>	Magne 1: 610 g Magne 2: 700 g Anchor: 290 g
<b>Material</b>	Anchor plate and magnet: steel Housing: Aluminium
<b>Holding force</b>	24 VDC: Min 1500 N 0 VDC: 0 N (Magne 1A/2A) 0 VDC: 30 N (Magne 1B/2B)
<b>Contacts</b>	Reed sensor (not safe)
<b>Switch current max</b>	100 mA
<b>Mechanical life</b>	>10 <sup>7</sup> switch operations
<b>Connector</b>	M12 5-pole male connector (Magne 1A, 1B, 2Ax, 2Bx) M12 8-pole male connector (Magne 2A, 2B)
<b>Connections</b>	Magne 1A/B: (1) Brown: Locking, +24 VDC (2) White: Sensor supply (3) Blue: 0 VDC (4) Black: NO-contact (5) Grey: NC-contact  Magne 2A/B: (1) White: Dynamic signal input (2) Brown: +24V DC (3) Green: Locking, +24V DC (4) Yellow: Locking, 0V DC (5) Grey: Info closed (max 10 mA) (6) Pink: Dynamic signal output (7) Blue: 0V DC (8) Red: Info locked (max 100 mA)  Magne 2Ax/Bx: (1) Brown: +24 VDC (2) White: Dynamic signal input (3) Blue: 0 VDC (4) Black: Dynamic signal output (5) Grey: Locking
<b>Conformity</b>	2006/42/EG EN ISO 12100-1/2:2003, EN ISO 13849-1:2008, EN 62061:2005, EN 1088
<b>Certifications</b>	TÜV Nord 

# Dimensions - Magne

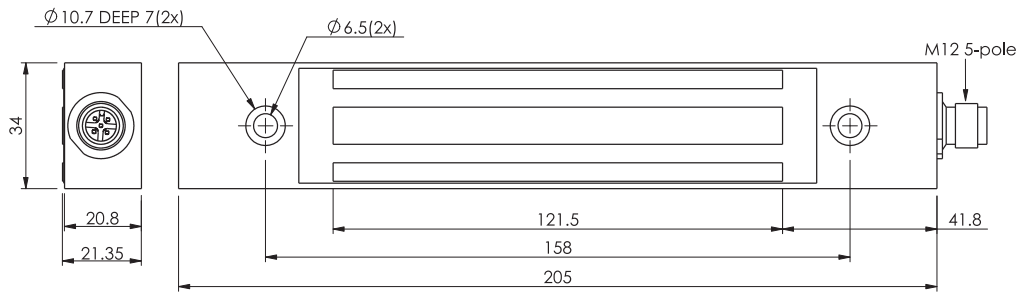

Dimensions Magne 1A/B

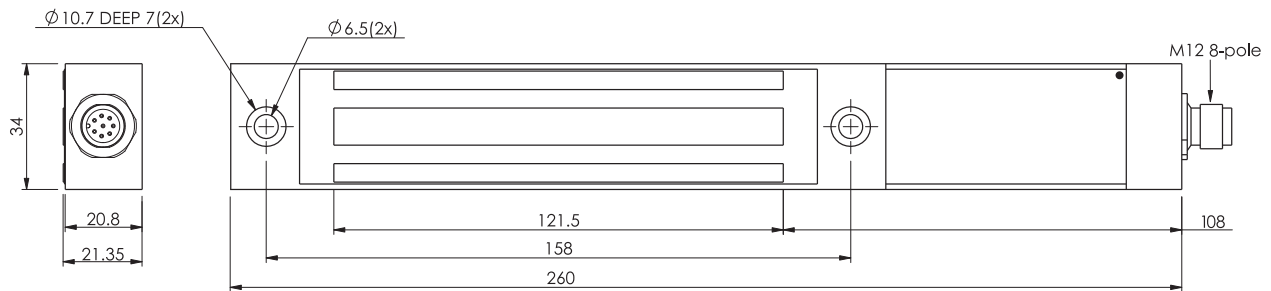

Dimensions Magne 2A/B

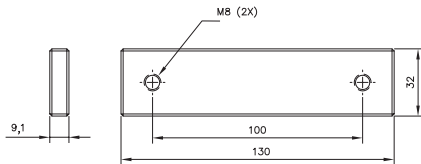

Dimensions Anchor plate  
(without permanent magnet)

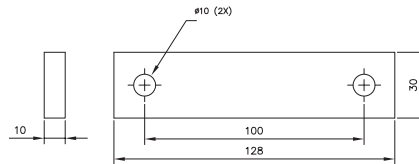

Dimensions - cell rubber

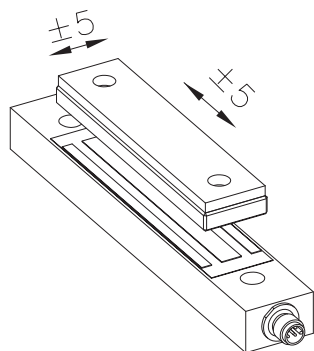

Installation tolerance (general)

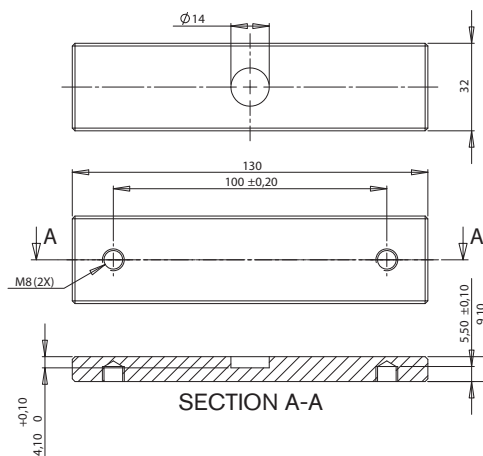

Dimensions Anchor plate  
(with permanent magnet)

## Holding force - Magne 1 and 2

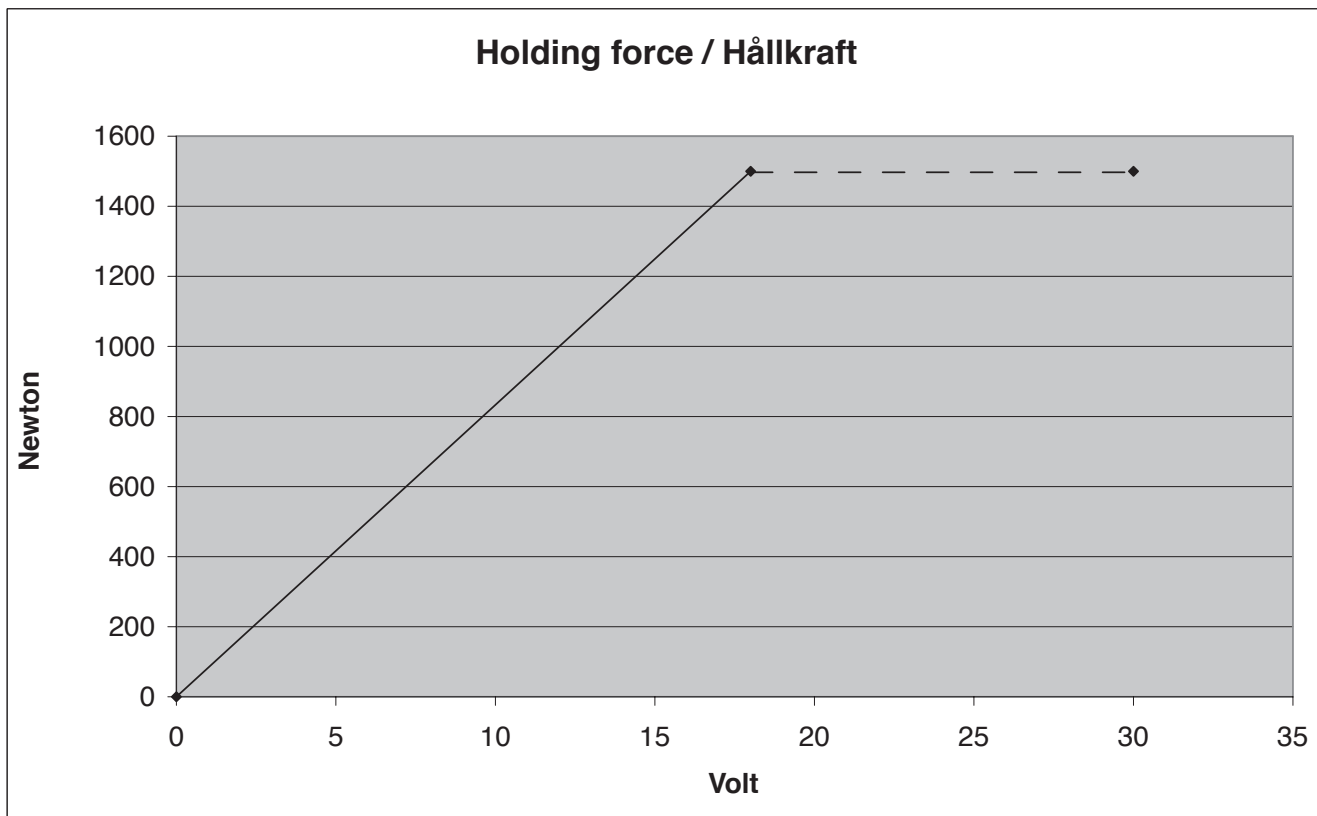

## Connection example - Magne 1 and 2

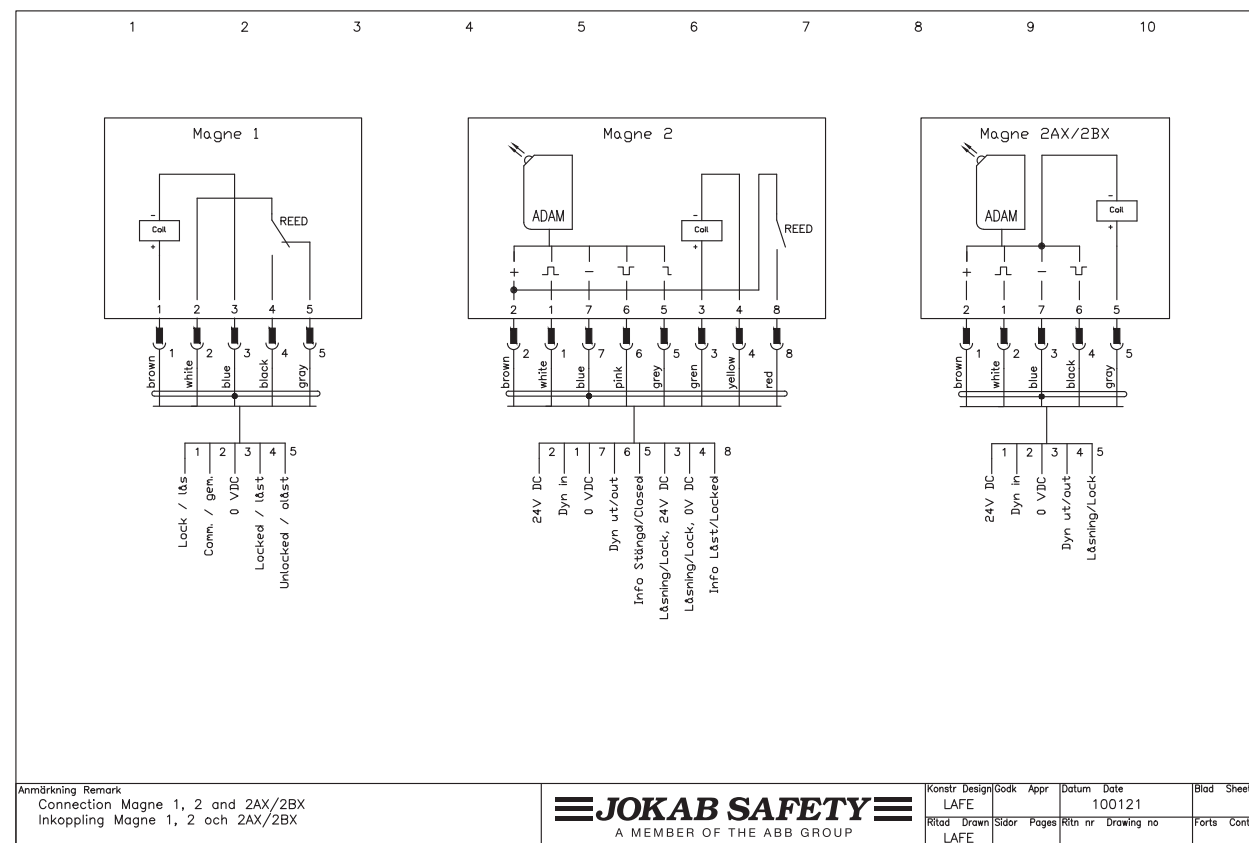



## Connection example - Magne 1 in series

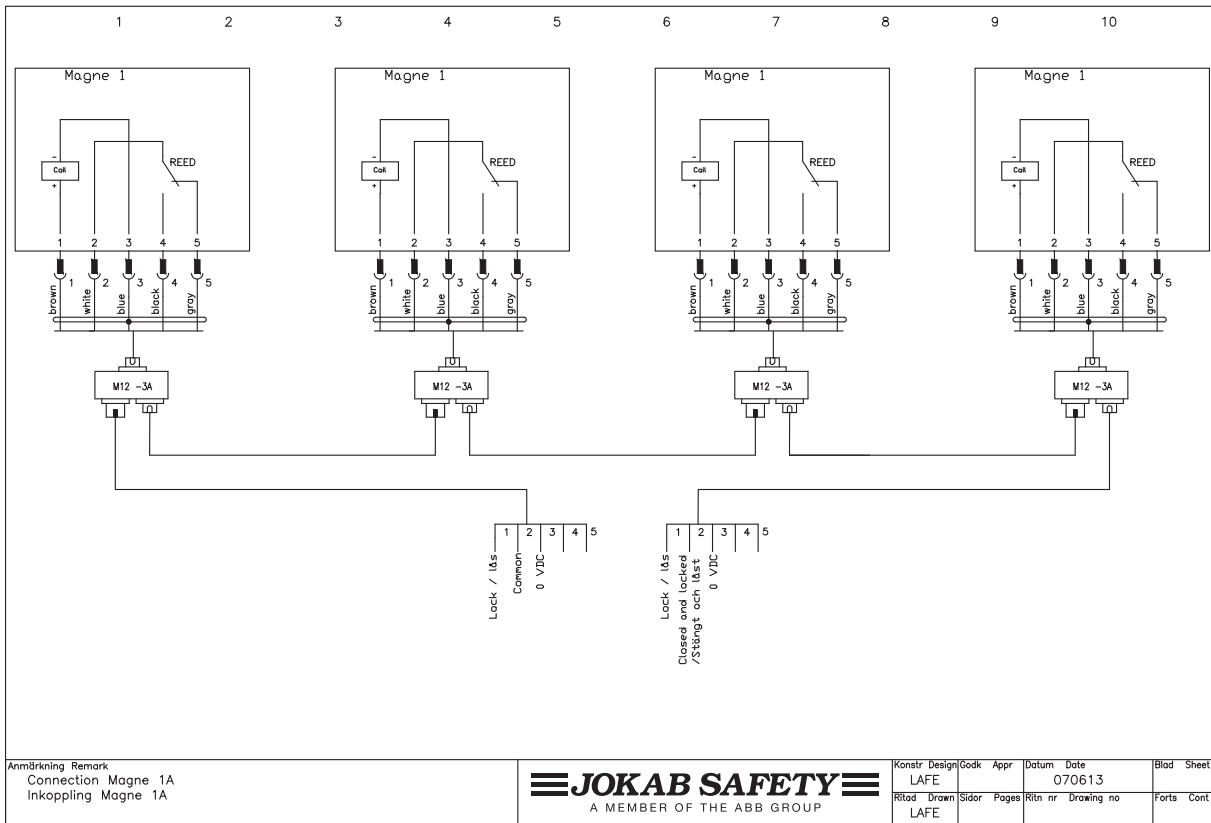

## Connection example - Magne 2 in series

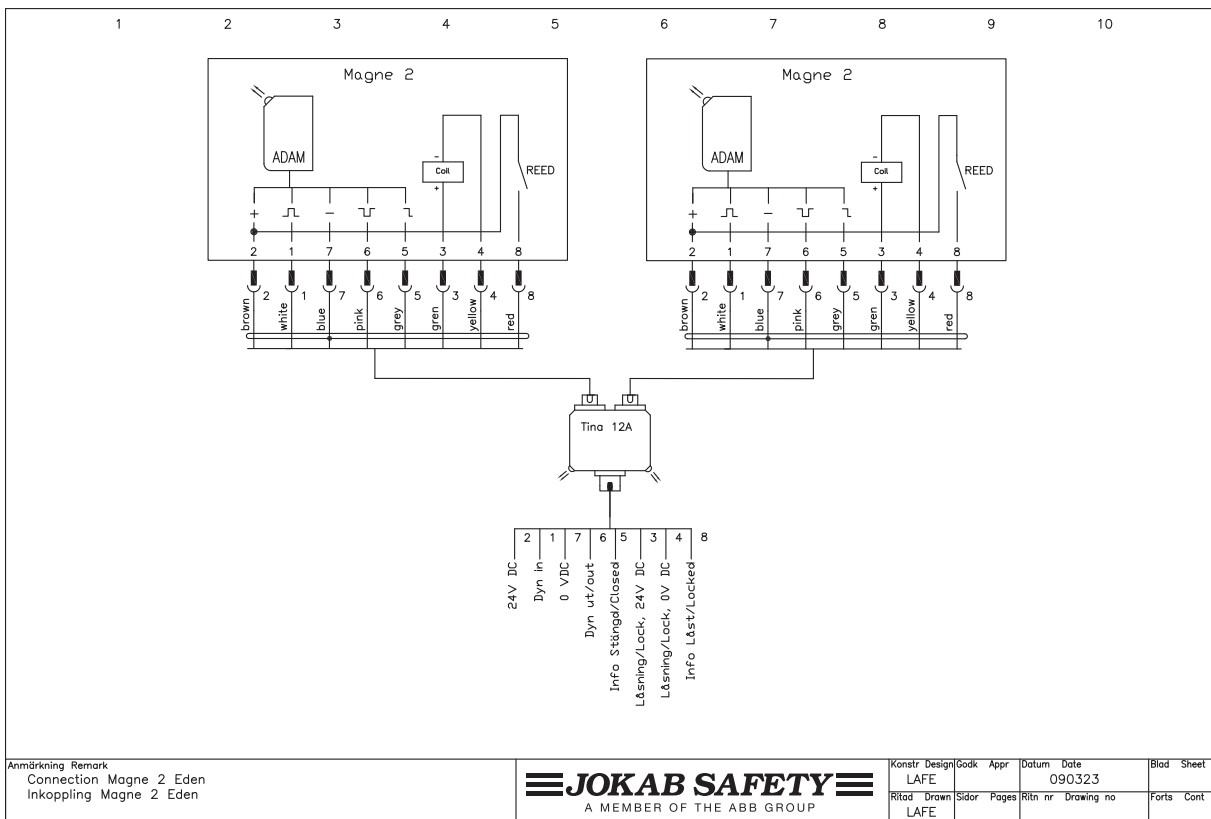

# Process lock

# Dalton

## Use:

Doors and hatches

## Advantages:

- Small and robust
- Integrated with Eden
- Flexible installation
- High enclosure classification – IP 67
- Withstands severe environments
- Low current consumption
- Status information with LED on the lock housing and in the cable connection.



### Dalton – the intelligent process lock

Dalton is a locking unit that is intended for use in preventing unnecessary process stoppages, i.e. it is not a safety lock. It can be used either as a free-standing lock or integrated with Eden as a safety sensor. In the unlocked state the door is held closed by a ball catch and in locked state the balls are mechanically blocked so the lock tongue can not be pulled out. If necessary, the holding force of the ball catch can be adjusted. The device only allows to lock when the ball latch is centred around the lock tongue, and when Eva is with Adam (depending on version). When an input is supplied with voltage, the ball catch is locked.

Dalton is easily connected with an M12 connector. The Tina junction block can be used for distribution of both the safety and locking functions. The Dalton status is indicated by LEDs and can also be read by a PLC via the information output.

### Dalton has a modular structure

The Dalton process lock has a modular structure and can be combined in different ways depending on position, installation and function. You choose the lock housing, lock tongue and fixing plate yourself to create a complete Dalton.

### Installation

Dalton offers many different installation possibilities as the lock tongue may enter the ball catch from three directions. In order to ensure that Dalton works without any problems, the ball catch must be resting, i.e. the balls not pressed in by the lock tongue when the door is in closed position. Dalton's brackets are therefore made to ensure easy adjustment of the lock tongue and ball latch positions.

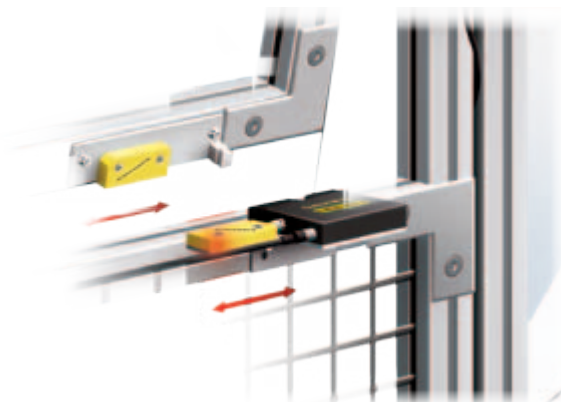

*Dalton is easy to install, adjust and dismantle in the Quick-Guard fence system's T-slots.*

## Modular structure - Dalton

### 1. Choose Dalton lock housing according to your preferences:

- Dalton M11/M31 If you only need to be able to lock your door/hatch (8-pin/5-pin M12)
- Dalton M12 If you want to lock your door/hatch and also have the interlocking switch Eden installed with one cable, common for both Dalton and Eden.
- Dalton L00 If you only need to use Dalton to keep the door fixed and closed



**Dalton M11**  
with 8-pin male contact



**Dalton M12**  
with 8-pin male contact,  
5 pin female contact for  
Adam



**Dalton M31**  
with 5-pin male contact



**Dalton L00**  
as ball latch, no electrical  
functions.

### 2. Choose a lock tongue depending on how the door/hatch is closed.

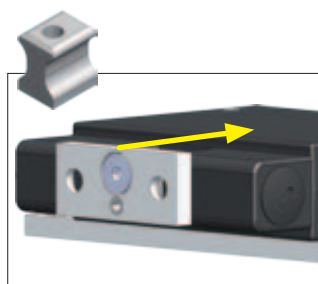

**Lock tongue A**  
Selected when the door  
closes to the Dalton front

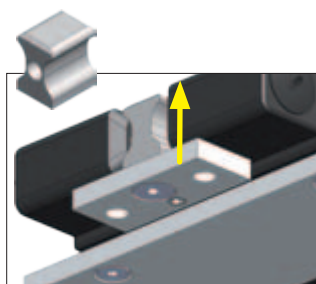

**Lock tongue B**  
Selected when the door closes to Dalton's upper or lower side

For Dalton L00 both lock tongues can be used regardless of the operating direction

### 3. Choose a fixing kit that fits your installation.



**Fixing kit 1**  
for Dalton and  
lock tongue



**Fixing kit 2**  
for Dalton and Adam  
and also for lock tongue and  
Eve

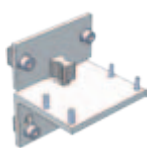

**Fixing kit 3**  
for Dalton  
adapted to  
ABB Jokab  
Safety fencing  
system



**Fixing kit 4**  
for Dalton and Eden  
adapted to ABB  
Jokab Safety fencing  
system

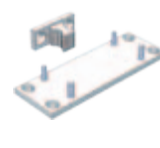

**Fixing kit 5**  
for Dalton, small  
bracket for lock  
tongue



**Fixing kit 6**  
for Dalton and  
Eden, small bracket  
for lock tongue

Read the manual for further information about correct installation of Dalton

## Accessories - Dalton

### Tina 12A junction block

Tina 12A can be used to connect two Daltons with Edens with one cable to the apparatus enclosure. The summed information that indicates the states of both the Dalton and Eden also goes to the apparatus enclosure.

### Transfer cables

A transfer cable can be used when the Dalton's 8-pole connector is to be connected to the 5-pole M12 connector of Tina 4A or Tina 8A. Note that the info-signals from Dalton and Adam cannot be used.

Technical data – Dalton	
<b>Manufacturer</b>	ABB AB/Jokab Safety, Sweden
<b>Artikelnummer/ beställningsdata:</b>	
Dalton L00 – Only ball latch, no electrical functions	2TLA020038R3000
Dalton M11 – 8-pin male plug	2TLA020038R3100
Dalton M12 – 8-pin male plug, 5-pin female to Adam	2TLA020038R3200
Dalton M31– 5-pin male plug	2TLA020038R3300
Lock tongue A – Lock tongue for front entry	2TLA020039R0800
Lock tongue B – Lock tongue for top and bottom entry	2TLA020039R1000
Fixing kit 1 – Fixing plates for Dalton and lock tongue	2TLA020039R0000
Fixing kit 2 – Fixing plates for Dalton and Adam and also for lock tongue and Eve	2TLA020039R0100
Fixing kit 3 – Fixing plates for Dalton adapted to ABB Jokab Safety fencing system	2TLA020039R0200
Fixing kit 4 – Fixing plates for Dalton and Eden adapted to ABB Jokab Safety fencing system	2TLA020039R0300
Fixing kit 5 – Fixing plate for Dalton, small bracket for lock tongue	2TLA020039R0400
Fixing kit 6 – Fixing plate for Dalton and Eden, small bracket for lock tongue	2TLA020039R0500
<b>Accessories</b>	
DA 1 – Spacer 2.5 mm for Adam and Eva.	2TLA020053R0000
M12-CT0214 – Transfer cable 0.2 m M12 5-pole male plug and 8-pole female plug	2TLA020060R0100
Tina 12A – Distribution block for two Dalton Edens with 8-pole cables	2TLA020054R1800
<b>Safety level</b>	
For interlocking switch Eden. Not valid for locking function. IEC/EN 61508-1...7	SIL3
EN 62061	SIL3
EN ISO 13849-1	Kat. 4/PL e
<b>PFH<sub>D</sub></b>	4,50×10 <sup>-9</sup>
For interlocking switch Eden. Not valid for locking function.	
<b>Locking function</b>	M - Locked when energised L - Only ball latch
<b>Colour</b>	Black
<b>Operating voltage</b>	24 VDC +25/-20%
<b>Current consumption</b>	
Unlocked	40 mA
Locked	130 mA
Lock input	5 mA
Information output	Max. 10 mA
<b>Eden</b>	See the data for Adam M12
<b>Operating temp. range</b>	-10°C to +55°C
<b>Enclosure classification</b>	IP67
<b>Holding force</b>	
Unlocked	25-100 N
Locked	2000 N

<b>Material</b>	Ball catch, securing plate Enclosure Lock tongue, securing plate	Anodised aluminium Anodised aluminium Stainless steel
<b>Chemical resistance</b>	Stainless steel  Anodised aluminium	Good resistance against most acids except hydrochloric acid and sulphuric acid. Very good resistance against corrosion, good resistance to most acids.
<b>Connections</b>		Connector to connect Dalton (varies depending on type) 8-pole male plug, M12 5-pole male plug, M12 Outlet for externally connected Adam female plug M12, 5-pole
<b>Colour markings (pins)</b>	Function	8-pole Colour      5-pole Colour
	Dynamic input signal, Adam	1 (White)
	+24 VDC	2 (Brown)      1 (Brown)
	Lock signal	3 (Green)      4 (Black)
	Not used	4 (Yellow)      2 (White)
	Information Adam	5 (Grey)
	Dynamic output signal, Adam	6 (Pink)
	0 VDC	7 (Blue)      3 (Blue)
	Information Dalton	8 (Red)      5 (Grey)
<b>Warning</b>	Dalton locks mechanically. If the lock is forced, the Dalton can be permanently damaged.	
<b>Conformity</b>	2006/42/EG EN ISO 12100-1:2003 EN ISO 12100-2:2003 EN ISO 60204-1 EN ISO 954-1 EN ISO 13849-1:2008	

LED indication – Dalton	
<b>LED indication</b>	Information function
	1 Locked
	0 Closed but unlocked
	0 Open
<b>Alarm:</b>	
	1Hz Lock has not entered the unlocked state
	1Hz Eden or ball catch not in position = open
	1Hz Open, locking not permitted
	1Hz Lock has not entered the locked state
	1Hz Undervoltage - locking not permitted
	1Hz Overvoltage
	1Hz Overtemperature (> 80°C)

# Dimensions – Dalton

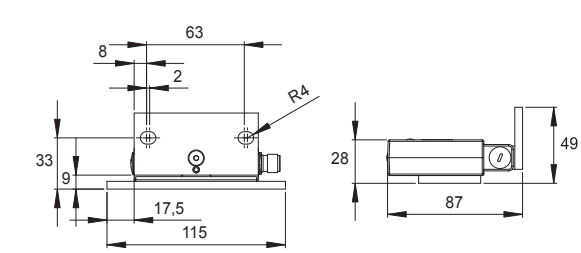

Bracket 1 with Dalton

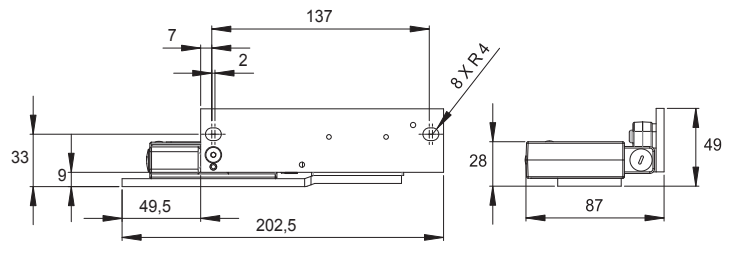

Bracket 2 with Dalton and Eden

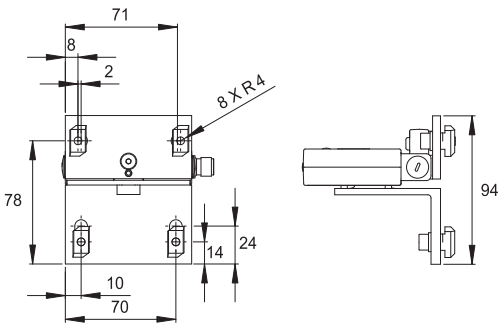
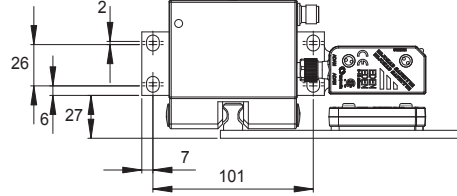
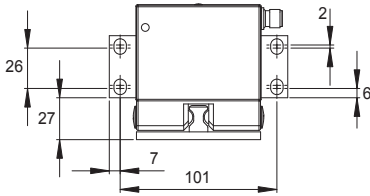

Bracket 3 with Dalton

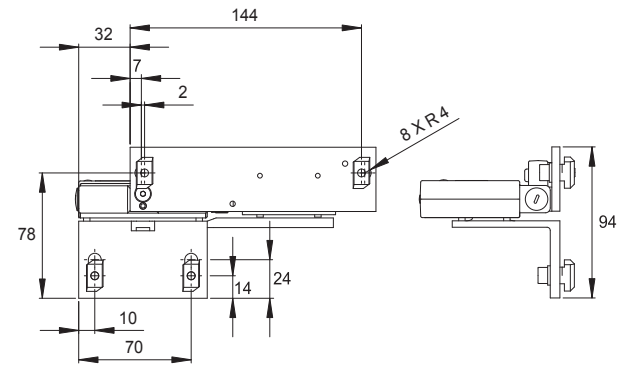

Bracket 4 with Dalton and Eden

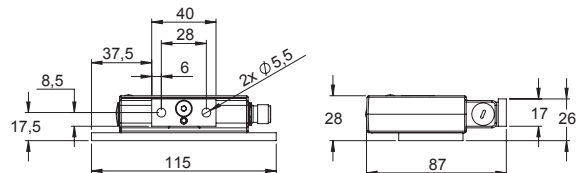
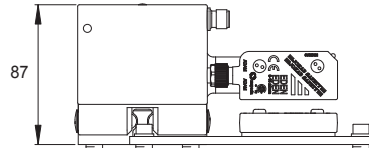
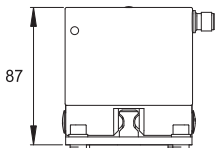

Bracket 5 with Dalton

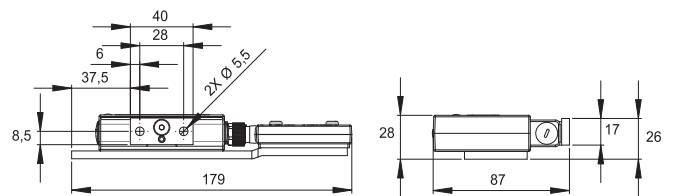

Bracket 6 with Dalton and Eden

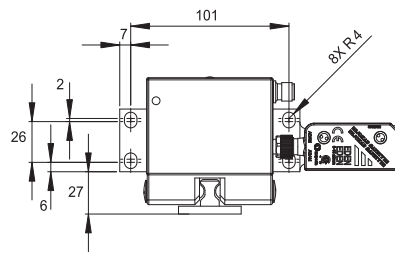
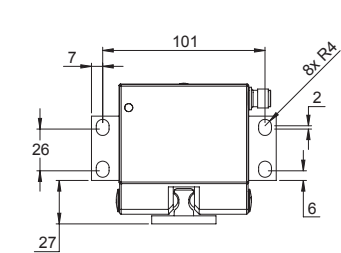

## Connection example – Dalton M11, M31 and M12

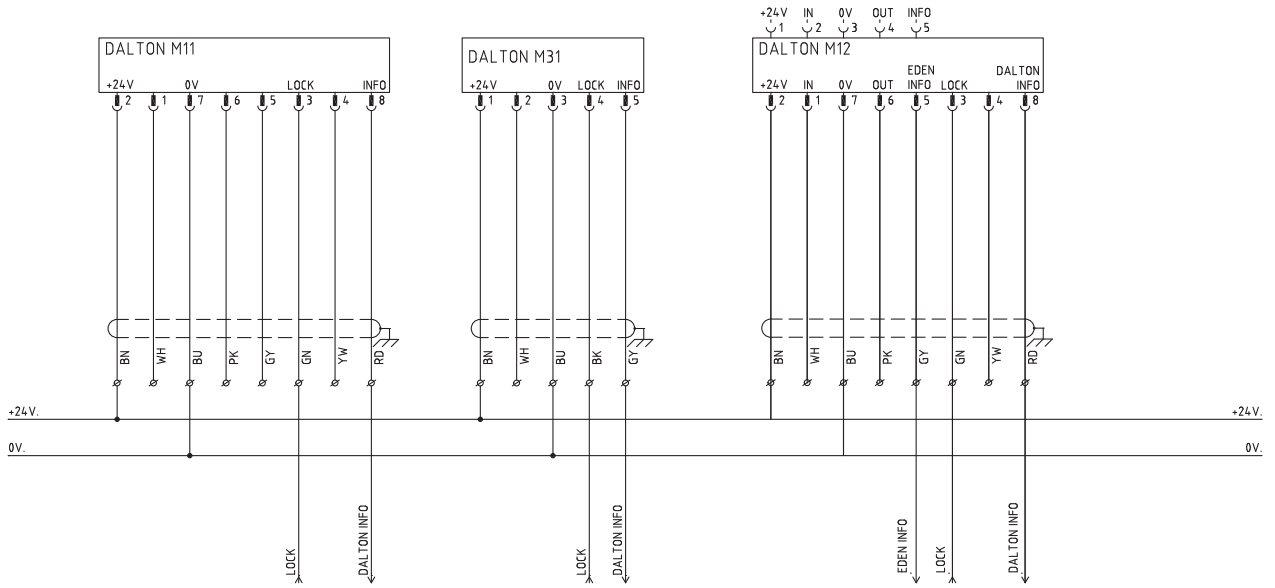

## Connection example – Dalton M12 and Vital

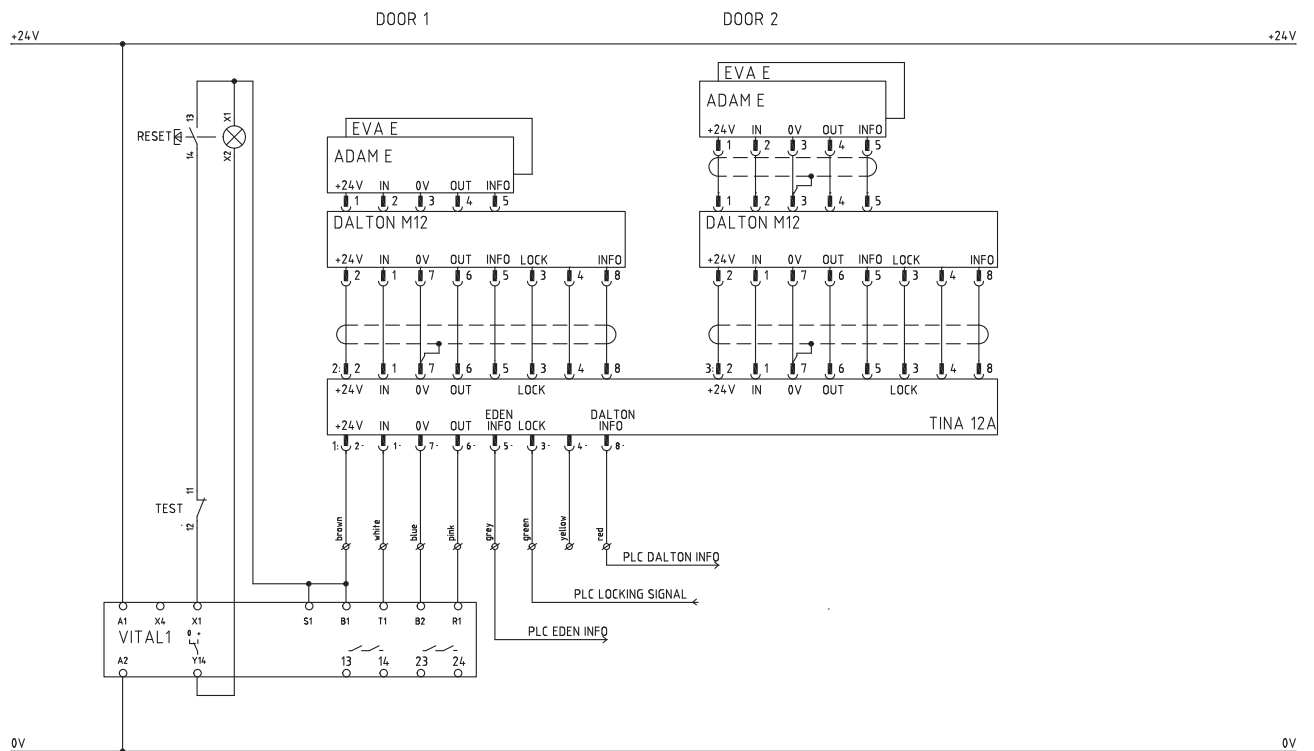



## Connection example – Dalton M12 and Eden through Tina 4A

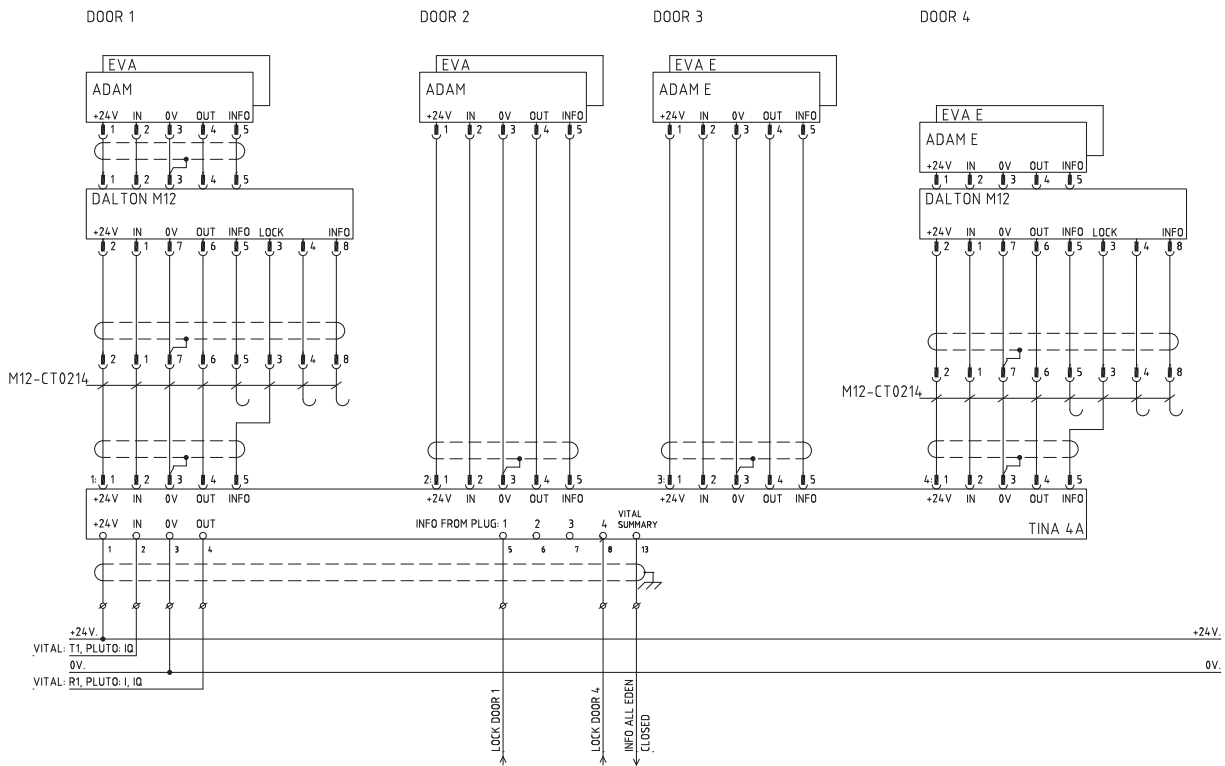

## Connection example – Dalton M12 and Eden through Urax A1 (AS-i)

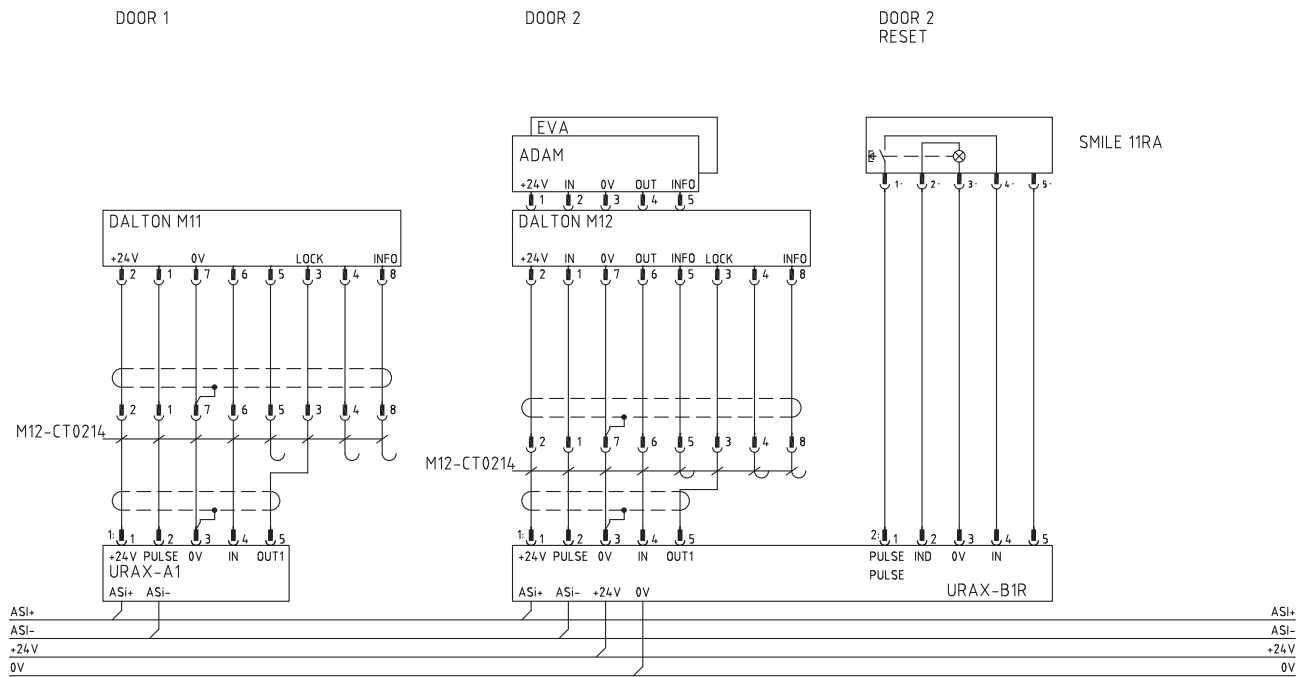

# Safety and process lock

# Knox



## Approval:



## Application:

Safe locking of door to a cell/line with long stopping time.

Prevents unintentional interrupts of processes

## Advantages:

Double locking function as specified in PL e/cat. 4 (EN ISO 13849-1)

Withstands harsh environments

Status information with LEDs on the lock and at cable connection.

Controlled to locked and unlocked positions - position remains in the event of power failure.

Electronic connection only on the door frame

Robust design

### **Knox - Double safety lock as specified in PL e/cat. 4**

Knox is a double lock that complies with the highest safety level (two lock cylinders with monitored positions) that can be used both as a safety and process lock. The locking function is electrically controlled and is bi-stable, i.e. it retains its position (unlocked/locked) in the event of a power failure. Dual signal for unlocking is safe at both short-circuits and cable breaks.

The handles operate as they would on a normal door but the exterior handle also have a reset function, why a separate reset button is not necessary and the interior handle that can be used for emergency opening also in locked state. The design and durability of the lock mean that it is ideal for harsh environments as the sensors are non-contact and the lock is manufactured of stainless steel. Knox is available in a number of adaptations such as left-hung door, right-hung door, inward and outward opening, with manual unlocking and for sliding door.



*Knox is easy to assemble, adjust and dismantle in and out of the T-slot of the Quick-Guard fencing system.*

## Knox in 4 different states

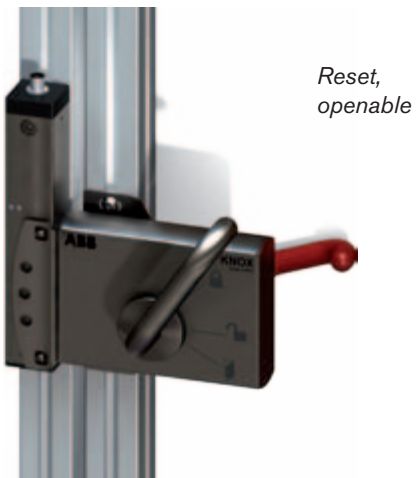
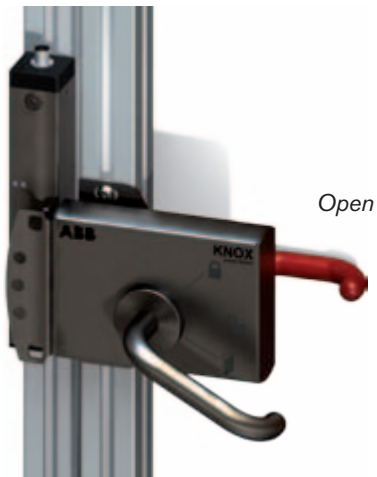

## Models and ordering data

Door part	
<b>Knox 1A-R v2</b> 2TLA020105R5000	Knox door part for outward-opening right-hung door
<b>Knox 1A-L v2</b> 2TLA020105R5100	Knox door part for outward-opening left-hung door
<b>Knox 1B-R v2</b> 2TLA020105R5200	Knox door part for inward-opening right-hung door
<b>Knox 1B-L v2</b> 2TLA020105R5300	Knox door part for inward-opening left-hung door
<b>Knox 1AX-R v2</b> 2TLA020105R5800	Knox door part for outward-opening right-hung door with the option for manual unlocking from the outside
<b>Knox 1AX-L v2</b> 2TLA020105R5900	Knox door part for outward-opening left-hung door with the option for manual unlocking from the outside
<b>Knox 1F-R v2</b> 2TLA020105R6000	Knox door part for sliding door that opens to the right. Incl. additional fastening fixtures for the frame.
<b>Knox 1F-L v2</b> 2TLA020105R6100	Knox door part for a sliding door that opens to the left. Incl. additional fastening fixtures for the frame.
<b>Knox 1BX-R v2</b> 2TLA020105R6200	Knox door part for inward-opening right-hung door with the option for manual unlocking from the outside
<b>Knox 1BX-L v2</b> 2TLA020105R6300	Knox door part for inward-opening left-hung door with the option for manual unlocking from the outside
<b>Knox 1FX-R v2</b> 2TLA020105R6400	Knox door part for sliding door that opens to the right with the option for manual unlocking from the outside. Incl. additional fastening fixtures for the frame.
<b>Knox 1FX-L v2</b> 2TLA020105R6500	Knox door part for sliding door that opens to the left with the option for manual unlocking from the outside. Incl. additional fastening fixtures for the frame.
Frame part	
<b>Knox 2A v2</b> 2TLA020105R2200	Standard Knox frame part 8-pin M12 contact, supplied for right-hung door. For instructions for turning, see the Knox manual
<b>Knox 2X v2</b> 2TLA020105R2300	Knox process lock, no duplicate unlocking signal, with 5-pin M12 contact
Accessories	
<b>PC plate for Knox on mesh door</b> 2TLA020106R0000	When mounting Knox on door with mesh the accessory PC plate for Knox is recommended. This is to avoid emergency opening from the outside.
<b>Escutcheon plate for Knox (without emergency release handle)</b> 2TLA020106R0600	When mounting Knox on a low door it is recommended to replace emergency release handle to prevent opening from the outside by reaching over.
<b>Tina 12A</b> 2TLA020054R1800	Distribution block for two Knox

*Knox door part 1A-R and frame part 2A*



*Knox door part 1A-L and frame part 2A*



*Knox door part 1B-R and frame part 2A*



*Knox door part 1B-L and frame part 2A*



*Knox door part 1F-R and frame part 2A*



*Knox door part 1F-L and frame part 2A*

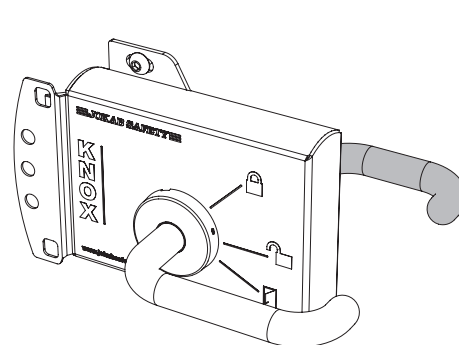

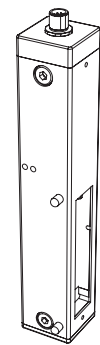

*Door part Knox1*

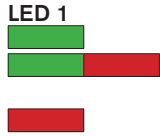

*Frame part Knox 2*

Technical data – Knox	
<b>Make</b>	ABB AB/Jokab Safety, Sweden
<b>Safety level</b> EN ISO 13849-1	Kat. 4/PL e
<b>PFH<sub>D</sub></b>	4,50 × 10 <sup>-9</sup>
<b>Lock function</b>	S/M - unlocked and locked with voltage.
<b>Operating voltage</b>	24 VDC +/- 15%
<b>Power consumption</b>	
Electronics	70 mA (in locked position)
Lock/lock inverse	135 mA (when locking/unlocking)
Total max	150 mA
Information output	Max. 10 mA
<b>Insulation class</b>	IP65
<b>Holding strength</b>	
Unlocked	5000 N (10,000 N ultimate breaking strength)
Locked	5000 N (10,000 N ultimate breaking strength)
<b>Connection</b>	Male plug M12, 8-pole
<b>Connections Knox 2A</b>	
Function	<b>8-pole</b> Colour
Dynamic input signal	1    (White)
+24 VDC	2    (Brown)
Lock	3    (Green)
Lock inverse	4    (Yellow)
Information Locked	5    (Grey)
Dynamic output signal	6    (Pink)
0 VDC	7    (Blue)
Information reset	8    (Red)
<b>Connections Knox 2X</b>	
Function	<b>5-pole</b> Colour
+24 VDC	1    (Brown)
Dynamic signal input	2    (White)
0 VDC	3    (Blue)
Dynamic signal output	4    (Black)
Lock	5    (Grey)
<b>Warning</b>	
Knox locks mechanically. Forcing the lock may damage Knox permanently.	
When mounting Knox on door with mesh the accessory PC plate for Knox is recommended. This is to prevent emergency opening from the outside.	
When mounting Knox on a low door it is recommended to replace emergency release handle with the accessory Escutcheon plate for Knox to prevent opening from the outside by reaching over.	
<b>Conformity</b>	2006/42/EG EN ISO 12100-1/2:2003, EN ISO 13849-1:2008, EN 62061:2005, EN 1088
<b>Certifications</b>	CE

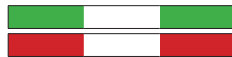
LED indicator – Knox	
<b>LED indicator</b> 	Function
<b>LED 1</b> 	Locked (and reset) Locked, no dynamic signal in
<b>LED 2</b> 	Unlocked Reset Not reset
<b>Alarm LED 2</b> 	<i>Dirt indicator reset sensor</i> Reset Not reset

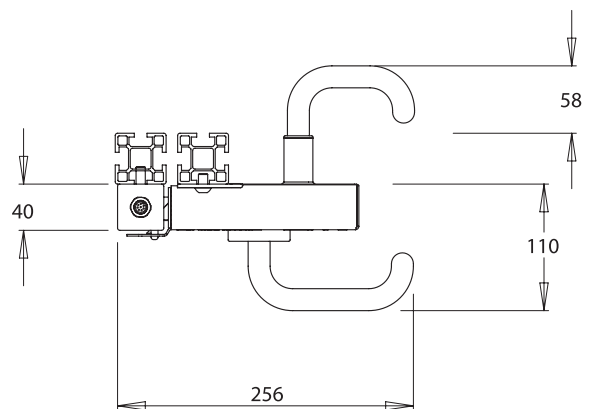
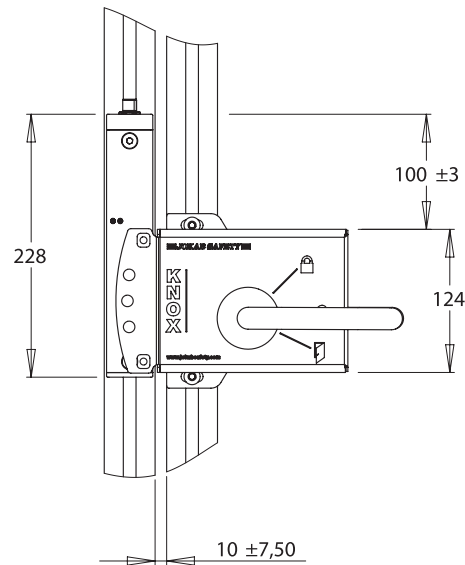

## Connection example - Knox

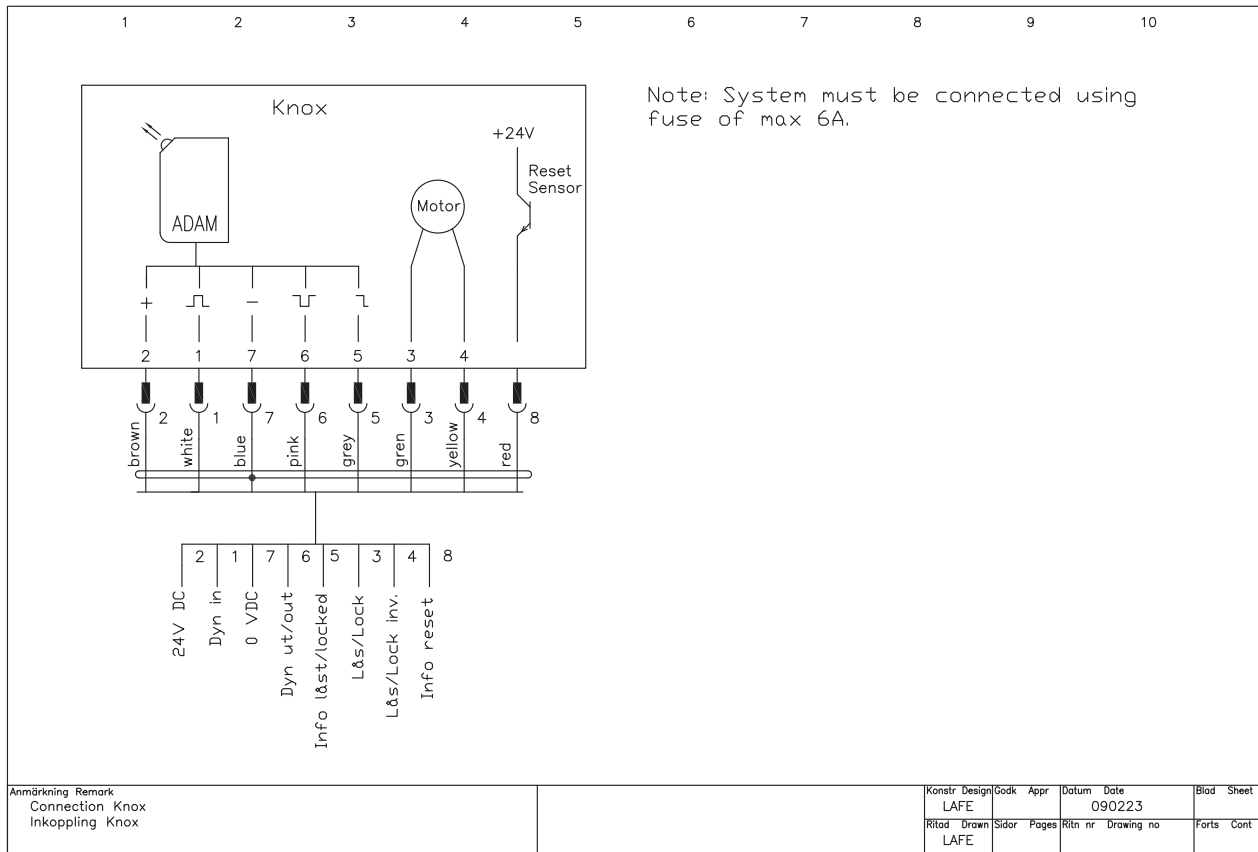

## Connection example - Knox with other unlocking

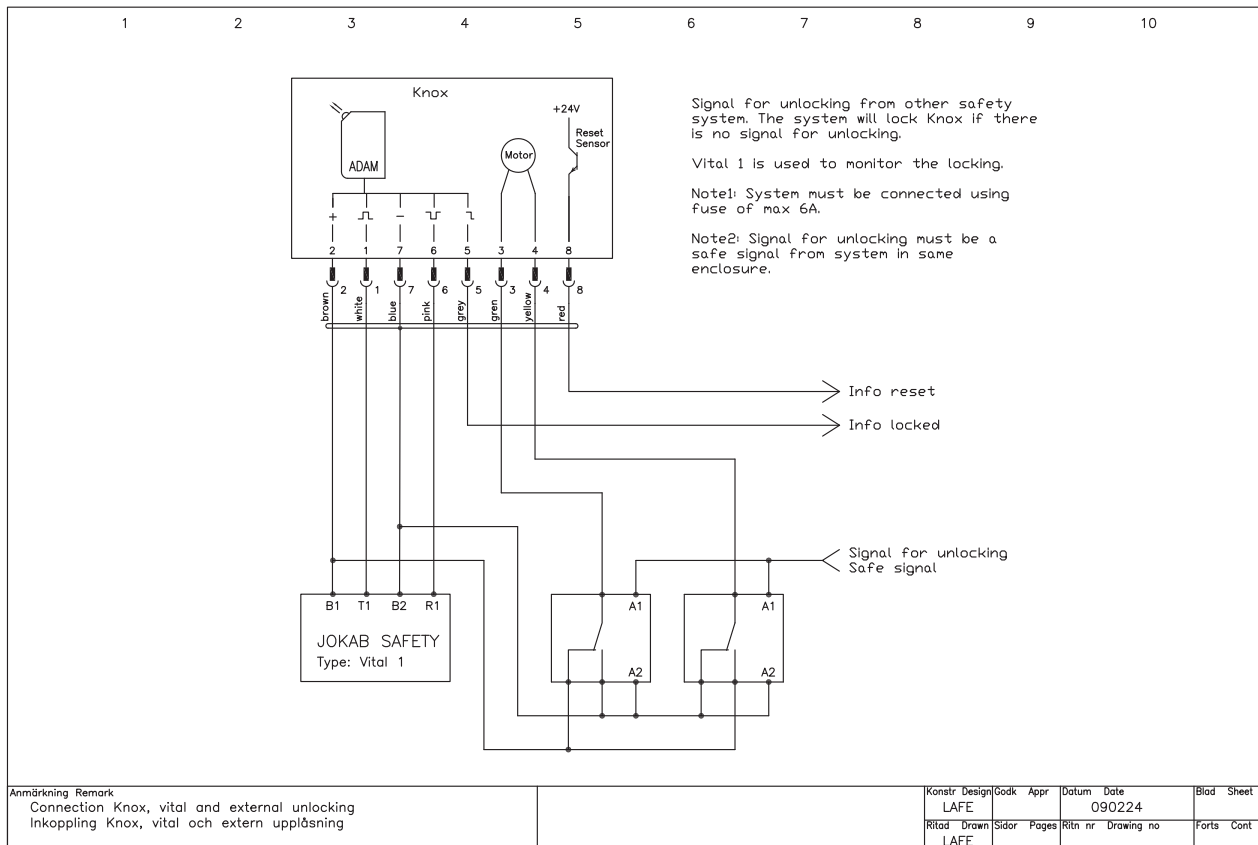



# Connection example - Knox with downtime monitor

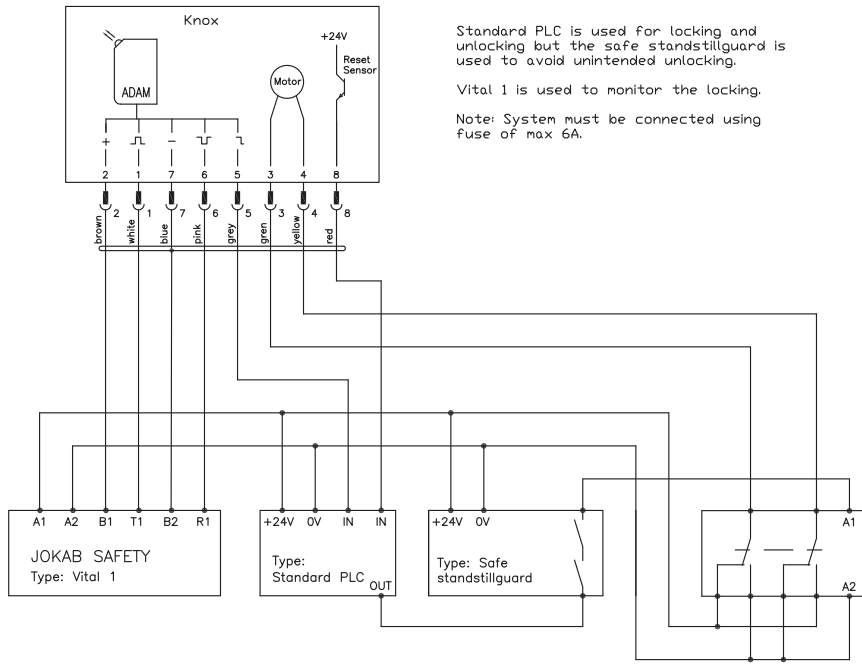

Standard PLC is used for locking and unlocking but the safe standstillguard is used to avoid unintended unlocking.  
 Vital 1 is used to monitor the locking.  
 Note: System must be connected using fuse of max 6A.

Anmärkning Remark Connection Knox, vital and standstillguard Inkoppling Knox, vital och stilleståndsvakt	Konstr Design	Gödk Appr	Datum Date	Blad Sheet
	LAFE		090224	
	Ritad Drawn	Sidor Pages	Ritn nr Drawing no	Forts Cont
	LAFE			

# Control devices



<b>Contents</b>	<b>Page</b>
<i>Why should control devices be used?</i> _____	<b>10:2</b>
<i>Three-position devices - JSHD4</i> _____	<b>10:4</b>
<i>Unique world-wide two-hand device - Safeball</i> _____	<b>10:12</b>
<i>Two hand device - JSTD20</i> _____	<b>10:20</b>

Descriptions and examples in this book show how the products work and can be used. This does not mean that they can meet the requirements for all types of machines and processes. The purchaser/user is responsible for ensuring that the product is installed and used in accordance with the applicable regulations and standards. We reserve the right to make changes in products and product sheets without previous notice. For the latest updates, refer to [www.abb.com/lowvoltage](http://www.abb.com/lowvoltage). 2011.

# Control devices

Why should Control Devices be used?

..for the machine operator to be able to directly start and stop dangerous machine movement.



## Three-position device

Three-position devices, hold-to-run devices and enabling devices are used during trouble-shooting, programming and test running when no other safety components are possible or suitable. The device is held in the hand and the operator can in an emergency situation either press harder or entirely release the device to stop the machine.

In an emergency situation the operator can either press harder or release the three-position device to stop the machine.



**Ergonomic three-position device, JSHD4**  
with double three-position button that gives a stop signal when released or fully pressed in.



### **Two-channel all the way out to the hand**

*Safeball is an ergonomic two-hand control device with four built-in buttons.*

## **Two-hand control device**

A two-hand control device is used when it must be guaranteed that the operator's hands will be kept outside the risk area. If there is a risk that someone else other than the operator can reach into the machine without the operator seeing it, the safety device must be supplemented by something more, e.g. a light beam.

To be able to operate the machine with the two-hand device, all the buttons on the device have to be operated within 0.5 seconds of each other. This is called concurrence. All the buttons also have to be returned to their initial position before one can start again. If any button is released during the machine movement the machine will be stopped. Using the stopping time one can calculate the necessary safety distance. A safety distance of less than 100 mm must not be used.

The highest safety level is assured by connecting the buttons of the two-hand device to a safety relay. The safety relay checks for concurrence and that all the buttons have returned to their initial position before a new start can be made. The safety relay also gives a stop signal if any of the buttons are released.

**The two-hand device protects against "after-grasp"; if the operator by reflex tries to enter or reach into a machine during the dangerous machine movement.**



**Safety foot operated switch** with three-position function.

**The foot operated switch is used when the operator has to hold the material with both hands during processing.**

## **Foot operated switches**

A foot operated switch is used when the operator has to hold the material during processing. The pedal must have a safety cover to prevent unintentional start. For seated work one must also have a foot support to facilitate the operator holding his foot in the pedal's off position.

The highest safety level is secured by monitoring the pedal with a safety relay.

# Three position device

# JSHD4

## Approvals:



## Use:

Troubleshooting  
Test running  
Programming

## Advantages:

Ergonomic  
LED information  
Adaptable  
Cheat Safe  
Adapted for AS-i



## The safest solution during trouble shooting, programming and testing

### Why three-positions?

An operator who is under pressure must be able to give a stop signal, whether in panic he/she pushes harder on the button or just lets go of it.

Three-position devices, hold-in and acceptance devices can be used for trouble shooting, programming and test running in situations where no other protection is available or feasible. If the operator has to enter a risk area to trouble shoot or run a test, it is extremely important that he/she is able to stop the machinery without having to rely on someone else to stand by a stop button that is further away. In addition, no-one else should be able to start the machinery from the outside after it has been stopped by use of the three-position device.

### Hold to run device or Acceptance device, what is the difference?

**Hold to run device:** The start signal is given when the button is pressed. The stop signal is given when the button is released or pushed fully in.

**Acceptance device:** The start signal for separate starting is given when the button is pressed. The stop signal is given when the button is released or pushed fully in. "Separate start" means, for example, that a program start signal is sent to the robot via a separate button in the acceptance device.

**The three-position device is designed to be ergo-**

### nomic

The device is ergonomic, both in respect of its shape, fitting to the hand, and the way the buttons are operated. It is easy to operate the three-position device using just the fingers, and the middle position provides a secure resting position. The device has LED indications that show the operational status, i.e. stop or ready signal. The two additional buttons can be used, for example, for start/stop, up/down or forward/back. Internally the device is duplicated. The three-position function itself is built up of two completely independent three-position buttons which are felt by the user to be one button.

### Cheat Safe three-position device with hand recognition

The three-position device JSHD4 has sensors which ensure that it is a human hand holding it. By using this, the safety level is increased, and the risk of manipulation or bypass of the safety function is reduced. It is no longer possible to expose the operator or odder to danger by trying to lock the three-position device in run mode.

### Three-position device adapted for AS-i

The three-position device JSHD4 also comes in a version adapted for direct attachment to the AS-i bus



## Highest safety level whether the button is pushed or released

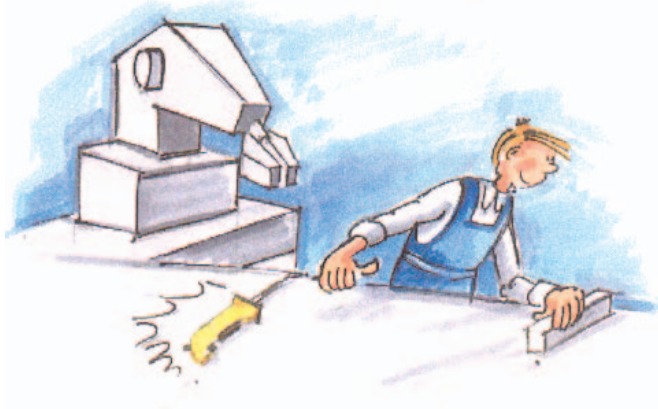

When the three-position button is released you will obtain a dual stop. It is essential that the machine stops when you put aside the three-position device, for example during adjustment.



When the three position button is pushed all the way in you will obtain a dual stop. It is essential that the machine stops in an emergency situation.

### How does a a three-position device work?

#### Safety level

A safe Enabling or Hold to Run device should function as follows:

1. The Stop signal in released (top) and bottom position shall have the same safety level.
2. Provide a 'Start' or 'Ready' signal in a distinct middle position.
3. After a 'Stop' in the bottom position, a 'Start' signal or 'Ready' signal is not permitted until the three position push-buttons have been totally released and again pressed to the middle position. This function is achieved mechanically within the three position push-buttons in the device.
4. A Short or Open circuit in the connection cables shall not lead to a dangerous function e.g. 'Start' or 'Ready' signal.

In order to meet the above conditions, the three-position switch must be connected to a suitable safety relay with a two channel function, e.g. RT6, RT9 or JSBT4, which can monitor that both three-position buttons are working and

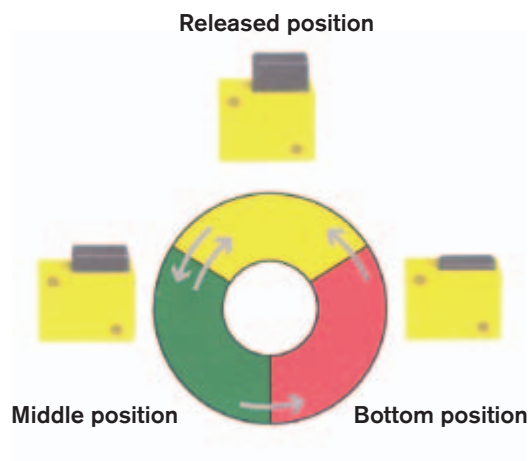

that there is no short or open circuit in the connection cable or the switch.

#### Regulations and standards

The JSHD4 is designed and approved in accordance with appropriate directives and standards. See technical data.

### Three-position devices in different versions



Three-position device fitted to a machine control unit.



Panel assembly of JSHD4H2 on a programming unit for robots.



## Design a three-position device for your needs

### 1. Choose between five different top units



**JSHD4-1**  
2TLA020006R2100



**JSHD4-2**  
2TLA020006R2200  
▪ LEDs  
▪ Front button  
▪ Top button



**JSHD4-3**  
2TLA020006R2300  
▪ LEDs



**JSHD4-4**  
2TLA020006R2400  
▪ LEDs  
▪ Front button



**JSHD4-5**  
2TLA020006R2500  
▪ LEDs  
▪ Top button

### 2. Choose a bottom part suitable for your assembly



**AA, AH, AJ**



**AB**



**AC, AD**



**AF, AG**



**AE**

**AA** – 2TLA020005R1000 with cable gland  
**AB** – 2TLA020005R1100 with Cannon connection  
**AC** – 2TLA020005R1200 with M12 connection (5 poles)  
**AD** – 2TLA020005R1300 with M12 connection (8 poles)  
**AE** – 2TLA020005R1400 with M12 connection (8 poles) and emergency stop

**AF** – 2TLA020005R1500 with M12 connection (4 poles) and 2 AS-i nodes (for front and top button)  
**AG** – 2TLA020005R1600 with M12 connection (4 poles) and 1 AS-i node (without front and top button)  
**AH** – 2TLA020005R1700 with cable gland and PCB with 10 screw connections  
**AJ** – 2TLA020005R1800 with cable gland and PCB with 16 screw connections

### 3. Choose hand recognition for making your three position device cheat protected (option)

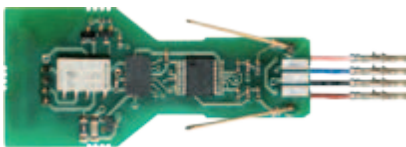

**Anti-tamper PCB** – 2TLA020005R0900

### 4. Check the table if your combination is available

### 5. Choose a bottom plate (option)

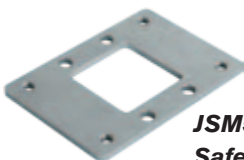

**JSM50G, bottom plate for Safety Interlock switch JSNY5** – 2TLA020205R6300



**JSM50H, bottom plate for non-contact sensor Eden (Eva)** – 2TLA020205R6400

## Available combinations of bottom- and top parts

	JSHD4-1	JSHD4-2	JSHD4-3	JSHD4-4	JSHD4-5
AA without Cheat Safe	JSHD4-1AA	-	-	-	-
AA with Cheat Safe	-	-	-	-	-
AB without Cheat Safe	-	JSHD4-2AB	JSHD4-3AB	JSHD4-4AB	JSHD4-5AB
AB with Cheat Safe	-	JSHD4-2AB-A	JSHD4-3AB-A	JSHD4-4AB-A	JSHD4-5AB-A
AC without Cheat Safe	JSHD4-1AC	-	-	-	-
AC with Cheat Safe	-	-	-	-	-
AD without Cheat Safe	-	JSHD4-2AD	JSHD4-3AD	JSHD4-4AD	JSHD4-5AD
AD with Cheat Safe	-	JSHD4-2AD-A	JSHD4-3AD-A	JSHD4-4AD-A	JSHD4-5AD-A
AE without Cheat Safe	-	-	JSHD4-3AE	-	-
AE with Cheat Safe	-	-	-	-	-
AF without Cheat Safe	-	JSHD4-2AF	JSHD4-3AF	JSHD4-4AF	JSHD4-5AF
AF with Cheat Safe	-	JSHD4-2AF-A	JSHD4-3AF-A	JSHD4-4AF-A	JSHD4-5AF-A
AG without Cheat Safe	-	-	JSHD4-3AG	-	-
AG with Cheat Safe	-	-	-	-	-
AH without Cheat Safe	-	JSHD4-2AH	JSHD4-3AH	JSHD4-4AH	JSHD4-5AH
AH with Cheat Safe	-	JSHD4-2AH-A	JSHD4-3AH-A	JSHD4-4AH-A	JSHD4-5AH-A

## Order your pre-assembled three position device from ABB Jokab Safety

Pre-assembled three position devices	Accessories
2TLA019995R0000	JSHD4-1AA
2TLA019995R0100	JSHD4-1AC
2TLA019995R0200	JSHD4-2AB
2TLA019995R0300	JSHD4-2AB-A
2TLA019995R0400	JSHD4-2AD
2TLA019995R0500	JSHD4-2AD-A
2TLA019995R0600	JSHD4-2AF
2TLA019995R0700	JSHD4-2AF-A
2TLA019995R0800	JSHD4-2AH
2TLA019995R0900	JSHD4-2AH-A
2TLA019995R1200	JSHD4-3AB
2TLA019995R1300	JSHD4-3AB-A
2TLA019995R1400	JSHD4-3AD
2TLA019995R1500	JSHD4-3AD-A
2TLA019995R1600	JSHD4-3AE
2TLA019995R1700	JSHD4-3AF
2TLA019995R1800	JSHD4-3AF-A
2TLA019995R1900	JSHD4-3AG
2TLA019995R2000	JSHD4-3AH
2TLA019995R2100	JSHD4-3AH-A
2TLA019995R2400	JSHD4-4AB
2TLA019995R2500	JSHD4-4AB-A
2TLA019995R2600	JSHD4-4AD
2TLA019995R2700	JSHD4-4AD-A
2TLA019995R2800	JSHD4-4AF
2TLA019995R2900	JSHD4-4AF-A
2TLA019995R3000	JSHD4-4AH
2TLA019995R3100	JSHD4-4AH-A
2TLA019995R3400	JSHD4-5AB
2TLA019995R3500	JSHD4-5AB-A
2TLA019995R3600	JSHD4-5AD
2TLA019995R3700	JSHD4-5AD-A
2TLA019995R3800	JSHD4-5AF
2TLA019995R3900	JSHD4-5AF-A
2TLA019995R4000	JSHD4-5AH
2TLA019995R4100	JSHD4-5AH-A
2TLA020055R1000	Connectors: M12-C01 M12 5-pole female, straight
2TLA020055R1600	M12-C03 M12 8-pole female, straight
2TLA020003R0300	JSHK0 12-pole connector for JSHD4
2TLA020057R0000	Cable with 5 conductors: C5 Cable 5x0,34 cut to length
2TLA020056R1000	M12-C101 10 m cable and connector
2TLA020056R1400	M12-C201 20 m cable and connector
2TLA020057R1000	Cable with 8 conductors: C8 Cable 8x0,34 cut to length
2TLA020056R4000	M12-C103 10 m cable and connector
2TLA020056R4100	M12-C203 20 m cable and connector
2TLA020003R5500	Cable with 12 conductors: HKC12 Cable 12x0,25 cut to length
2TLA020003R4700	HK5 Cable 5 m and connector
2TLA020003R4800	HK10 Cable 10 m and connector
2TLA020003R4900	HK20 Cable 20 m and connector
2TLA020003R5000	JSHK16S4 spiral cable 1,6 m and connector
2TLA020003R5100	JSHK20S4 spiral cable 2,0 m and connector
2TLA020003R5200	JSHK32S4 spiral cable 3,2 m and connector
2TLA020003R3500	JSHK40S4 spiral cable 4,0 m and connector
2TLA020003R3600	JSHK3604 spiral cable 6,0 m and connector
2TLA020003R5300	JSHK80S4 spiral cable 8,0 m and connector
2TLA020003R5400	HK-T2 Cable drum and connector
2TLA040005R0500	Brackets: JSM55 Wall bracket for three position device
2TLA040005R0700	JSM5B Wall bracket for 2 JSNY5 (ordered separately)
2TLA020200R4600	Others: JSHD4 protection coat

## Three-position devices for different types of montage

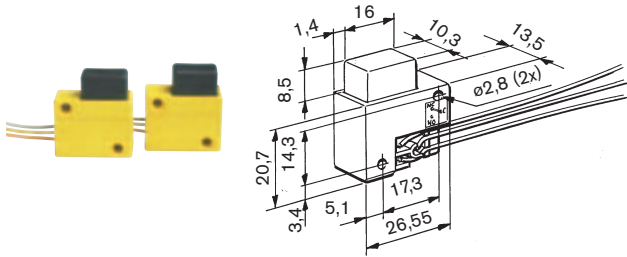

### Three-position push button JSHD2C

The button is the main component in a safe three-position solution. To achieve the highest safety level two buttons are used in a two-channel system.

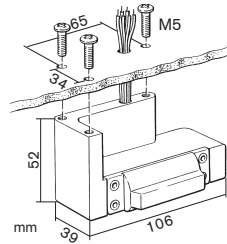

### External assembly JSHD4H2A

The external assembly is similar to the panel assembly unit, although it is a 'handle' design making it suitable for assembly on the outside of a control box.

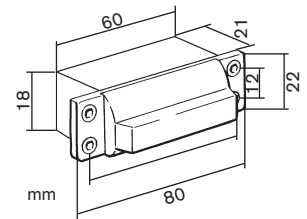

### Panel assembly JSHD4H2

A panel assembly suitable for building into programming units or similar control boxes. Provides simultaneous activation of both of the three-position buttons.

#### Standard versions

2TLA020002R0200	JSHD4H2A Three-position device for external panel assembly
2TLA020002R0700	JSHD4S2 Three-position device, ABB upgrading kit
2TLA020002R3100	JSHD4H2 Three-position device for internal panel assembly
2TLA020001R1000	JSHD2C type E Three-position button
2TLA020001R1300	JSHD2C type K Three-position button

Complete JSHD4 with standard options are available to order separately

### Technical data - JSHD4

<b>Manufacturer</b>	ABB AB/Jokab Safety, Sweden
<b>Safety level</b> EN ISO 13849-1	Category 4/PL e
<b>Electrical contact ratings</b> Three-position button:	30 VDC, max 0.5 A (min. 10 mA, 10V)
Extra button:	50 VAC/DC max 0.2 A
<b>Protection class</b>	IP 65
<b>Operating temperature</b>	-10 to +50° C
<b>Function indication</b> Three-position buttons ready signal:	'Yes', green LED 'No', red LED
<b>Material</b>	Polyamide 6.6
<b>Insulation resistance</b>	min 20 M Ohm
<b>Operation force</b>	approx. 15 N
<b>Mechanical life</b>	1 000 000 cycles to middle position
<b>Conformity</b>	AFS 1994:48, EN ISO 12100-1/-2, EN 954-1/EN ISO 13849-1

Pin	Color STD	Color JSHK-S
A	White	White
B	Brown	Brown
C	Green	Green
D	Yellow	Yellow
E	Grey	-
F	Pink	Grey
G	Blue	Pink
H	Red	Blue
I	Black	Red
J	Purple	-
K	-	-
L	-	-

STD: JSHK, JSHK-E, JSHK-T

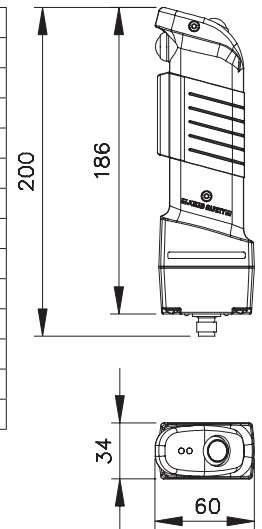

Cable, available in different lengths.



JSHD4 protection coat



Spiral cable, available in different lengths.



JSHK0 12 pole connector for JSHD4.



JSM5B Wall bracket for interlock switches and three-position device.



JSM55 Wall bracket for three-position device.



Cable drum

## Connection example - Three-position device JSHD4 to Pluto

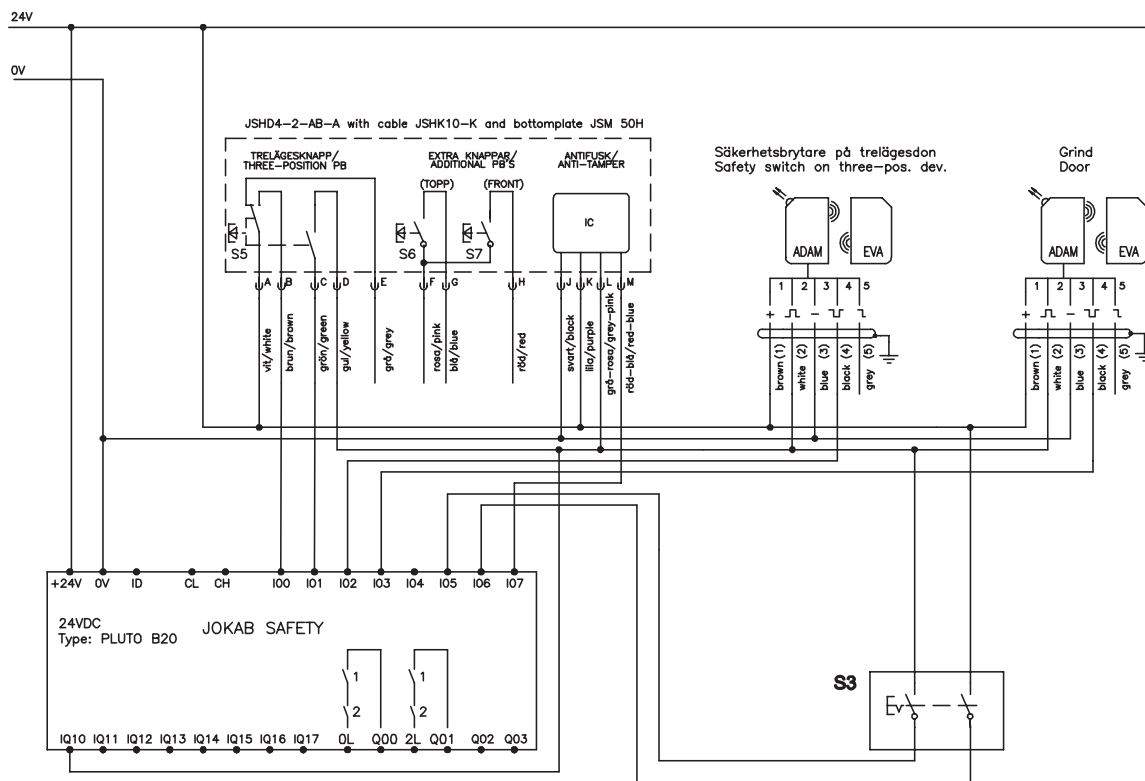

### Time-limited entrance/exit

After lifting the three-position device out of its holder JSM54A, the interlocked gate can be passed for entrance into the risk area within x sec. The time limit is set in the Pluto program. The device detects the operators hand and prohibits tampering.

## Connection examples - Three-position device JSHD4 with various safety controllers

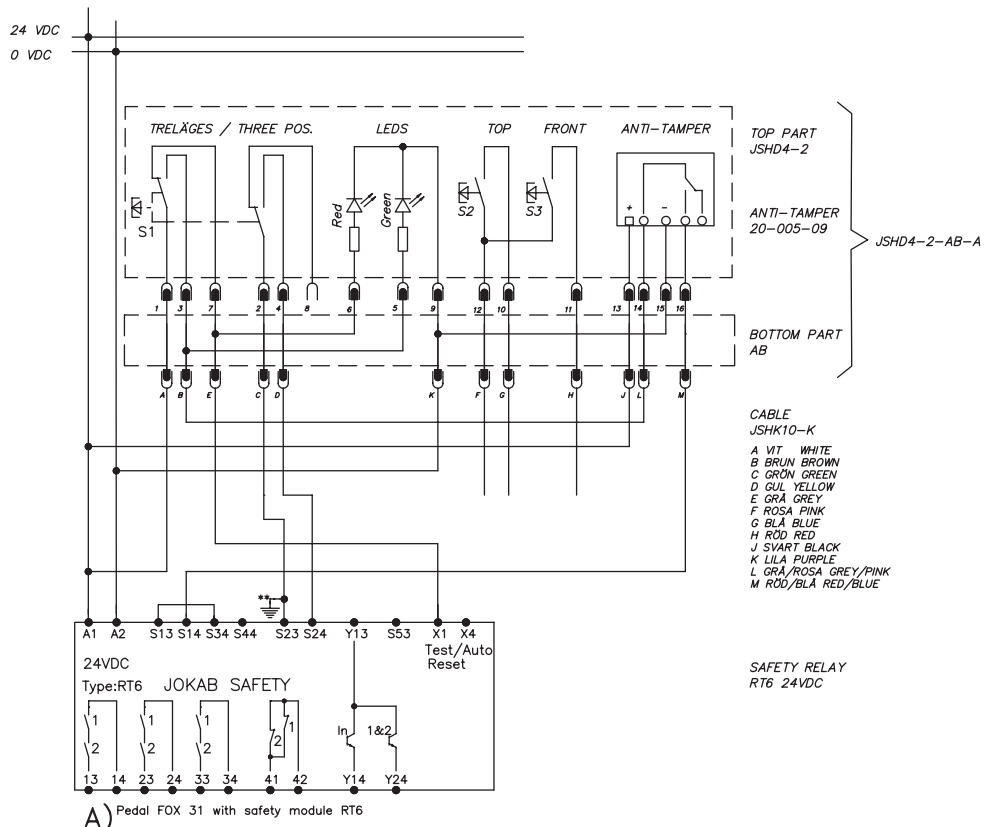

## Connection with bottom parts AB

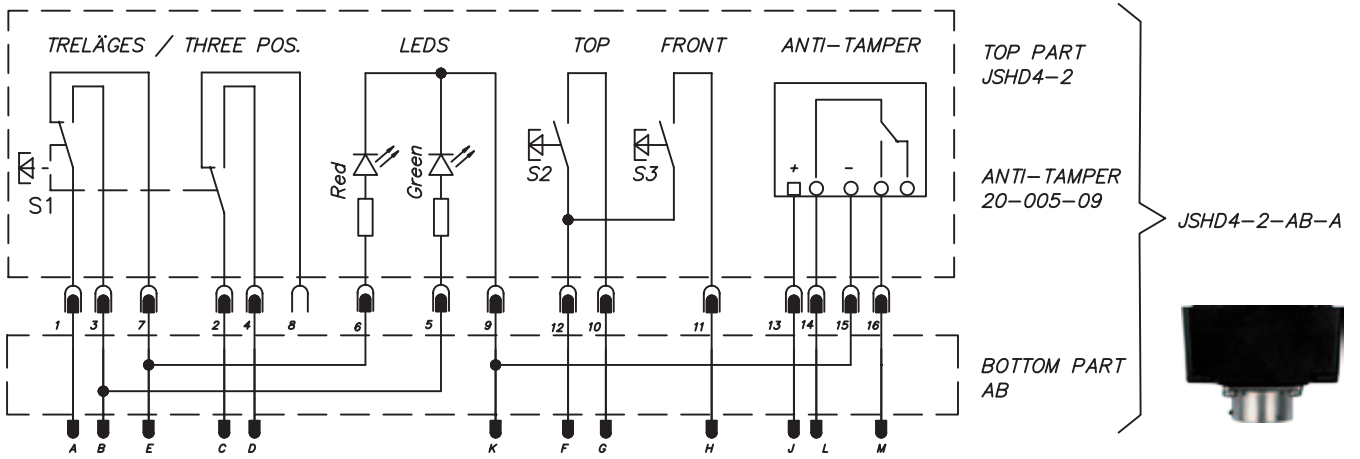

## Connection with bottom parts AC

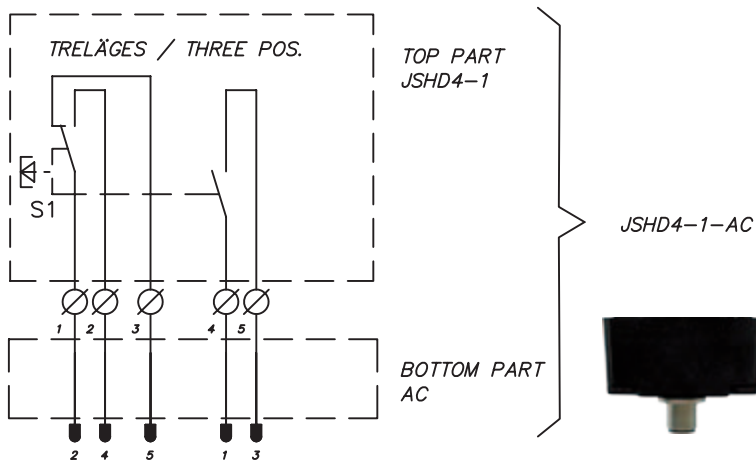

## Connection with bottom parts AD

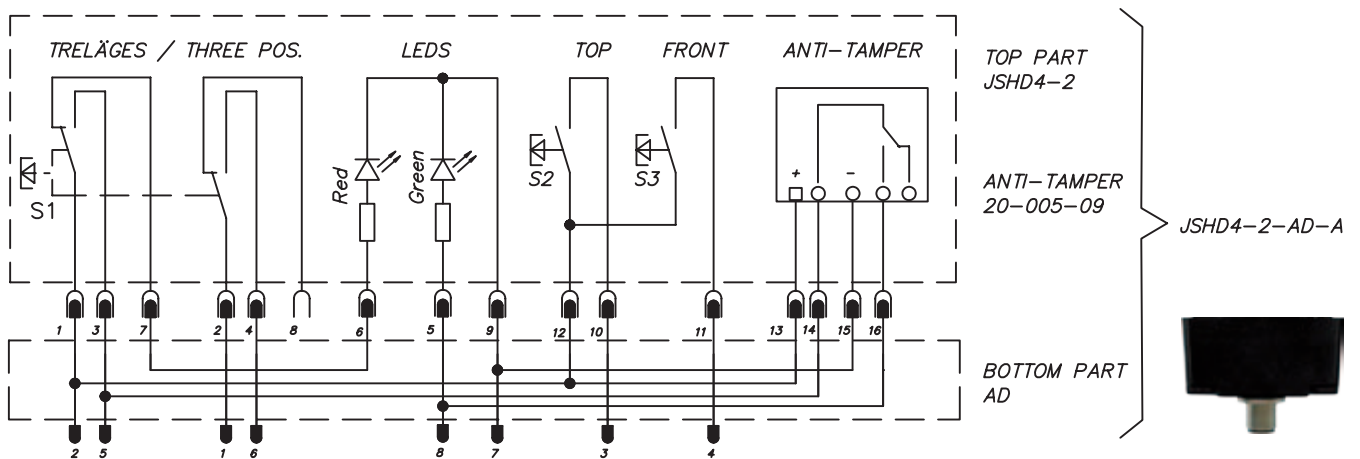



## Connection with bottom parts AE

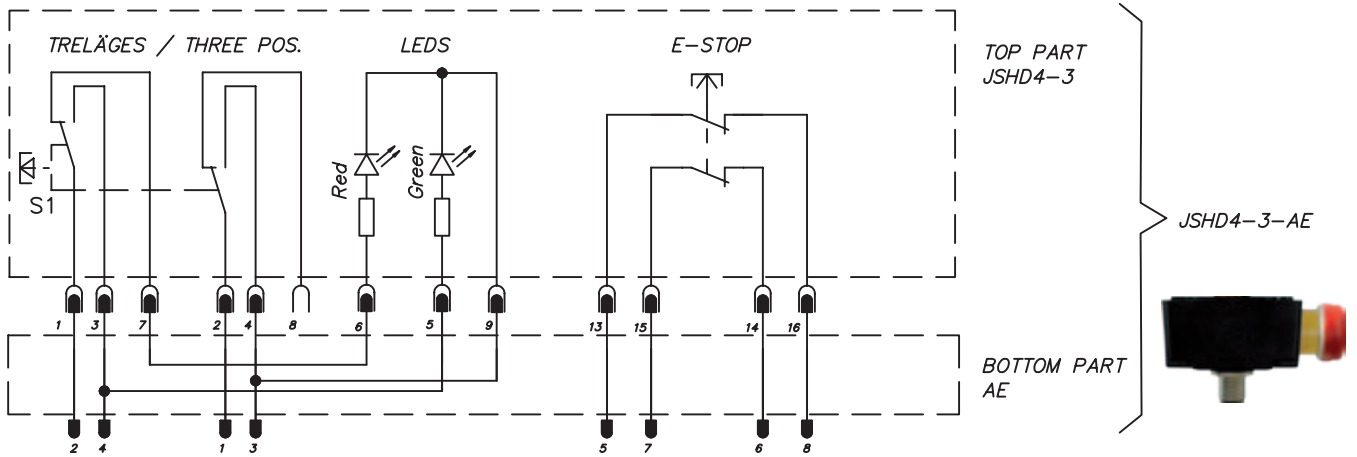

## Connection with bottom parts AH

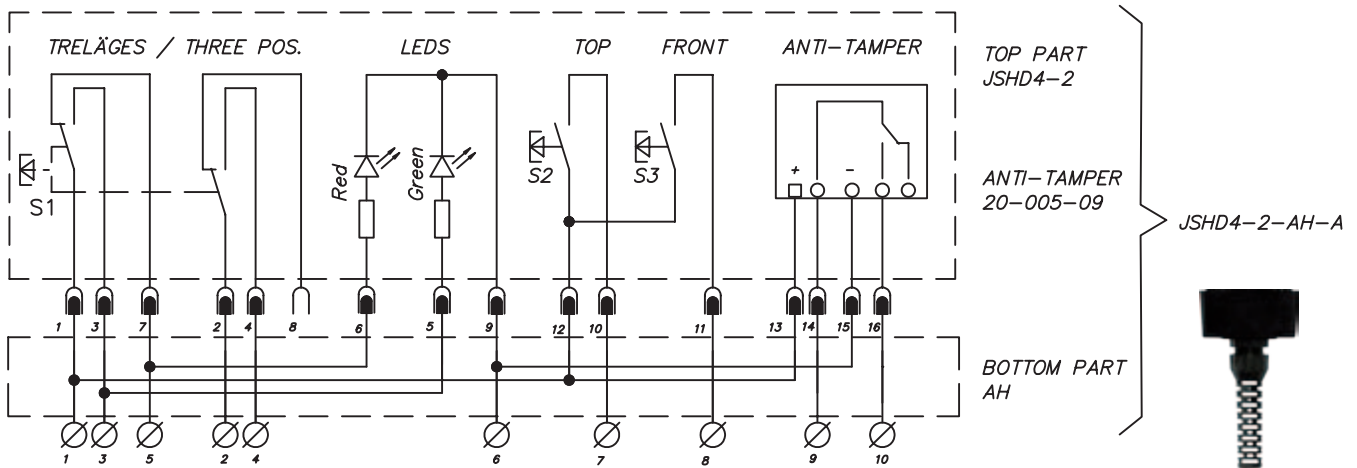

## Connection with bottom parts AJ

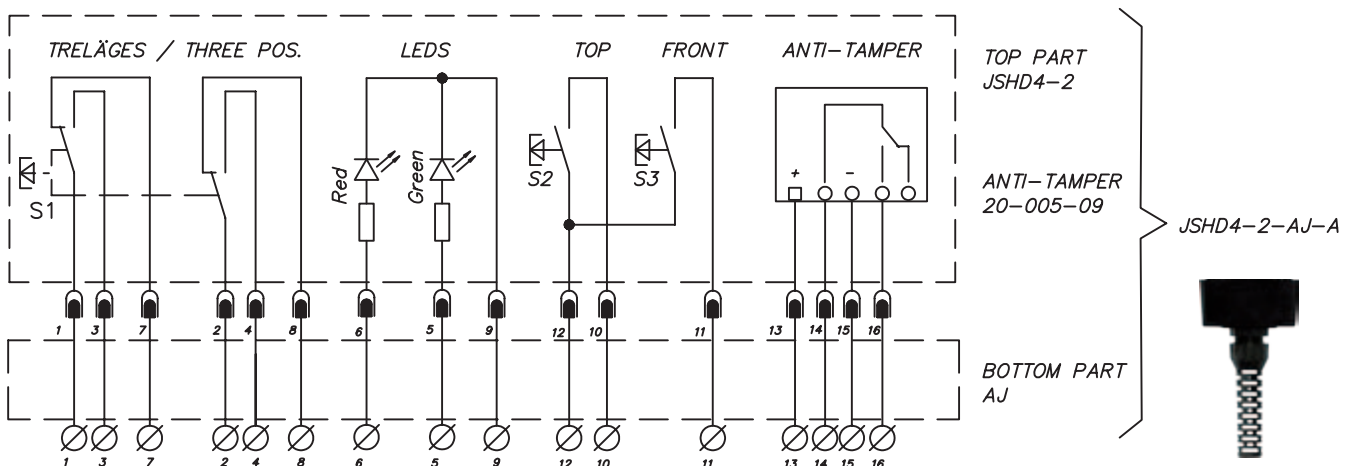

# One and two hand devices

# Safeball™

## Approvals:



## Safeball for:

- Presses
- Punches
- Fixtures
- Shearing machines

## Features:

- Ergonomic
- Low activation force
- Flexible mounting
- Several grip possibilities
- Highest safety level
- Two channel switching in each hand



A two hand device which is comfortable and easy to use.



## SAFEBALL™

### Unique World Wide Two hand device

Safeball™ consists of a spherical ball containing two embedded pushbutton switches, one on each side of the ball. By using this pushbutton configuration, the risk of unintentional activation is minimised and the device is simple and ergonomic to use.

Safeball™ can be utilised for either One hand (one Safeball™) or Two hand (two Safeballs™) applications. In either application, and in order to meet the required level of safety, the Safeball™ switches are monitored by specified/certified ABB Jokab Safety Safety relays (see electrical connection).

In the case where Two hand control is used, both Safeballs™ i.e. all four pushbuttons have to be activated within 0.5 seconds. If one or more pushbuttons are released a Stop signal is given to the machine. In order to provide the highest level of safety the Safeball™ design provides the operator with a dual switching function and short-circuit supervision in each hand.

Each Safeball™ is ergonomically designed and has both its cover and actuator made of environmentally-friendly polypropylene. The design allows for comfort of use for all hand sizes and operation from numerous gripping positions. Mounting of the Safeball™ is also very flexible allowing the device to be mounted in the most ergonomic position for the operator.

### When can a Two hand or One hand control be used ?

A Two hand control can be used when it is necessary to ensure that the operator is outside and must be prevented

from reaching into the hazardous area. If the operator decides, after the start signal has been given to the machine, to make an 'after-grasp' i.e. try to adjust the part that has been placed into the machine, then a dual stop signal is given to the machine.

A one hand control device can be used when the operator cannot reach the hazardous area with his/her free hand or on less dangerous machines.

### Highest Safety Level

The Safeball™ is certified by Inspecta in Sweden for use as a Two hand control device, when used with a JSBR4 ABB Jokab Safety Safety relay or Pluto Safety-PLC, in accordance with the highest safety level in standard EN 574 (type IIIc).

### Two hand device adapted for AS-i

The two hand device, Safeball also comes in a version adapted for direct attachment to the AS-i bus.

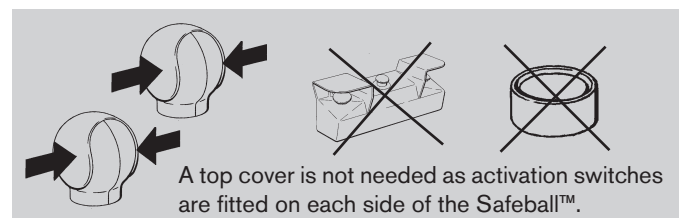

Technical data - Safeball	
<b>Manufacturer:</b>	ABB AB/Jokab Safety, Sweden
<b>Article number/Ordering data:</b>	
JSTD1-A Safeball 1 NO + 1 NC with 2 m cable	2TLA020007R3000
JSTD1-B Safeball Safeball 1 NO + 1 NC with 0.2 m cable	2TLA020007R3100
JSTD1-C Safeball 1 NO + 1 NC with 10 m cable	2TLA020007R3200
JSTD1-E Safeball 2 NO 0,2 m cable	2TLA020007R3400
<b>Material:</b>	Polypropylene
<b>Colour:</b>	Yellow and black
<b>Size:</b>	Height: approx. 71 mm, Diameter, min.: 68 mm Diameter, max.: 72 mm Diameter, base: 42 mm
<b>Weight:</b>	0.2 kg with 2 m cable 0.7 kg with 10 m cable 0.1 kg with 4x0.2 m wires
<b>Safety level:</b>	EN ISO 13849-1 EN 954-1
	Up to category 4/PLe Up to category 4
<b>Temperature:</b>	0°C to +55°C (operating) -20°C to +70°C (storage)
<b>Protection class:</b>	IP67. Not intended for use under water
<b>Operating force:</b>	Approx. 2 N
<b>Actuator travel:</b>	1.3 +/- 0.6 mm
<b>Max switching load:</b>	30 V 2A DC, resistive load
<b>Recommended load:</b>	24 V 10mA DC
<b>Min switching load:</b>	6V 10mA DC, resistive load
<b>Contact resistance:</b>	100 mohm
<b>Life, mechanical:</b>	> 1x10 <sup>6</sup> operations at max. 1 Hz

<b>Life, electrical:</b>	Dependant upon electrical load characteristics
<b>Connection cable:</b>	
JSTD1-A:	2m PVC-cable, 4 x 0.75mm <sup>2</sup>
JSTD1-B, JSTD1-E:	4 x 0.75mm <sup>2</sup> wires, approx. 0.2 m
JSTD1-C:	10 m PVC-cable, 4x0.75 mm <sup>2</sup>
<b>Conformity:</b>	EN ISO 12100-1:2003, EN ISO 12100-2:2003, EN 574+A1:2008

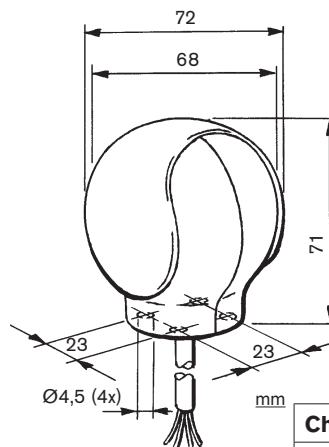

Chemical resistance at 20°C	
Chemical	Resistance
Alcohols	good
Paraffin oil	good
Milk	good
Silicon oil	good
Acetone	good

Please contact us for more information.

## Function - Safeball

### Two hand control device

The Two hand control device is implemented by using two Safeballs™, each having two internal pushbuttons. The Safe-balls™ must be mounted a minimum distance between each other (see Mounting description).

By utilising two pushbuttons in each device a double safety function is provided in each hand.

The highest safety level is achieved by connecting all four pushbuttons to the ABB Jokab Safety JSBR4 safety relay or Pluto Safety-PLC. The safety relay gives a dual and supervised safety function and requires input activation within 0.5 seconds in order to start the machine. It also checks that all four pushbuttons have returned to their deactivated positions before a new start is allowed. The JSBR4 safety relay also provides a stop signal if one or more pushbuttons are released.

### One hand control device

Safeball™ is also a very practical method of providing a one hand control device as it is very easy to find and activate by the machine operator. One hand devices should only be used when the operator cannot reach into the hazardous area with his/her free hand or on less dangerous machines. Before fitting the necessary risk assessment must be made to determine suitability of this type of control. To achieve the highest safety level for One hand control the Safeball™ must be connected to a ABB Jokab Safety safety relay (See Electrical Connection).

### Versions

Safeball is available in several versions to meet different mounting requirements.

- **JSTD1-A** - The standard version with actuators made of plastic and 2 m of cable.
- **JSTD1-B** - Similar to the standard version but without a cable. Instead it has four wires, each 0.2 m long.
- **JSTD1-C** - Similar to JSTD1-A but with 10 m cable.
- **JSTD1-E** - Similar to JSTD1-B but with 2 NO contacts.

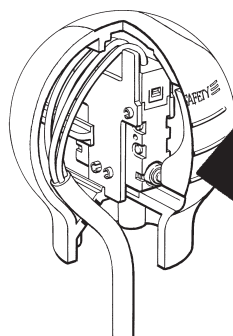

Activation of a pushbutton.

Safeball™, JSTD1, is certified by DNV Inspecta.  
Approval number:  
01-MAL-CM-0101 (Two-hand device)  
01-MAL-CM-0100 (One-hand device)

## Mounting - Safeball

The Safeballs™ can be mounted in many different ways. They can be mounted on a table, a machine, on a support or wherever suitable for ergonomic reasons. The Safeball™ can be mounted in a fixed position or on a tilting and/or rotating support. This flexibility of mounting permits the Safeball™ to be fitted in the best ergonomic position for the ease of operation by the operator. The distance requirement between two Safeballs™ or between a Safeball™ and a wall or edge of a table depends on how the Safeball™ is mounted. Safeball™ can be mounted with four M5 screws or ST4.8 self-tapping screws.

**Note:** When Safeballs™ are mounted in such a way that the distance between them can be adjusted to less than the specified minimum, the mounting screws must be locked to ensure any changes in the distance between the two balls cannot be made.

### Alternative mounting methods

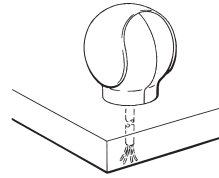

Mounting on a table.

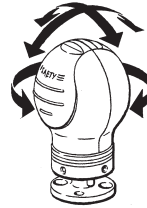

Mounting with ball joint, which can be rotated and angled.

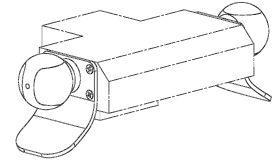

Example of alternative mounting.

### Approved Two hand device

To be an approved Two hand device, both Safeballs™ must be mounted a minimum distance apart in order to prevent operation of both balls with one hand. Safeballs™ must be fitted a minimum distance from the edges of tables or a wall. It is essential that Safeballs™ are correctly installed in order to prevent unintended activation of the devices with part of the body in combination for example with a wall.

## Mounting distance - Safety distance - Safeball

### Mounting distance

Table mounting of two Safeballs™. In order to prevent cheating the distances shown are the minimum allowed.

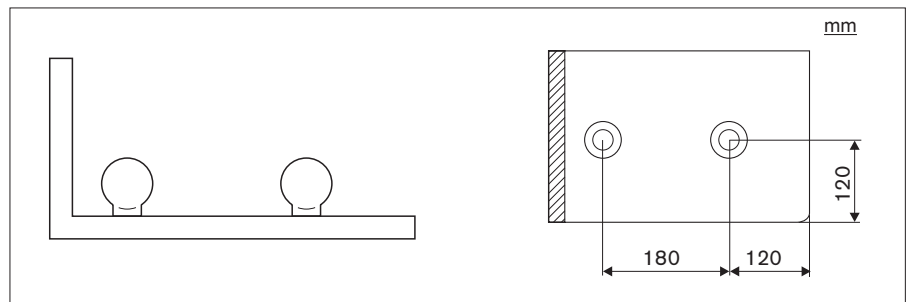

### Safety distance

The Safety distance is the distance between the Safeballs™ and the dangerous machine movement. The safety distance requirement can be calculated using the following formula for Safeball™ in accordance with the approving authority and EN ISO 13855:  
 $S = K \times T + C$

### Where

S= safety distance in mm  
 K= hand speed, 1600 mm/s  
 T= total stopping time for the dangerous movement (including the response time of the safety relays in seconds)  
 C= Constant= 0 mm for Safeball.

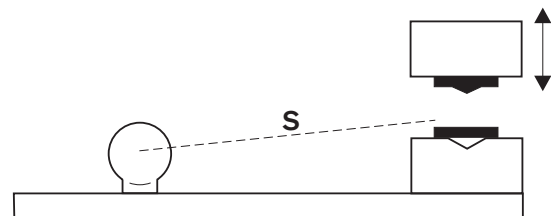

The safety distance is the distance between the Safeballs™ and the dangerous machine movement.

**Note:** S must never be less than 100 mm.

# Electrical connection - Safeball

## Two hand device

Safeballs™ are designed to be connected to a ABB Jokab Safety JSBR4 Safety relay or Safety PLC to achieve the highest safety requirements for a Two hand device.

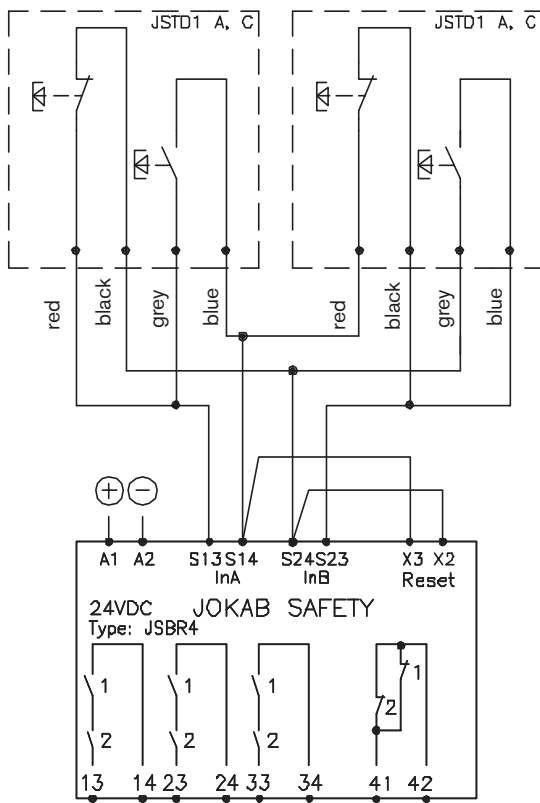

Example of two devices connected to a ABB Jokab Safety JSBR4 safety relay. Response time on receiving a stop signal from JSTD1 < 15 ms.

## One hand device

When used as a One hand device the Safeball™ is designed to be connected to a ABB Jokab Safety RT6, RT7 or RT9 Safety relay in order to achieve the highest possible safety level for this type of control.

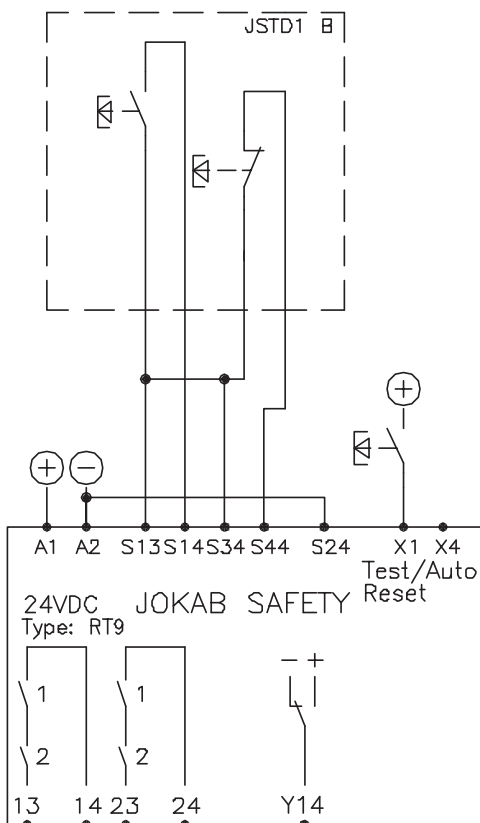

Example of a single Safeball™ connected to a ABB Jokab Safety relay RT9. The response time at 'stop' is < 20 ms.

# Two hand control station JSTD25 with Safeball

With a JSTD25 two hand control station you have a prepared two hand unit that is easy to install, while utilising the good ergonomics of the Safeball. There are several variants to meet differing needs. All versions meet EN 574, EN 954-1 and EN 13849-1 and are supplied with the internal connections made, to simplify installation.

## JSTD25 for fixed installation

JSTD25 A-E: Two Safeballs mounted on a steel housing. Replaces a traditional two hand device. Is available with an emergency stop button and ball joint fixtures for the Safeballs. Three 22 mm openings are prepared on the top for buttons or signal lamps. Hatch for wiring routeing in the

base, securing holes for mounting on the rear. The Safeballs are connected to terminal blocks, for the user to connect the external wiring through one of the two inlet alternatives (underneath or at the rear).



**JSTD25A** Article no. 2TLA020007R5000 Two hand control station with 2 Safeballs.



**JSTD25D** Article no. 2TLA020007R5300 Two hand control station with 2 Safeballs, JSMC5.



**JSTD25B** Article no. 2TLA020007R5100 Two hand control station with 2 Safeballs and emergency stop button.



**JSTD25E** Article no. 2TLA020007R5400 Two hand control station with 2 Safeballs, JSM C5 and emergency stop button.



## For mobile installation



### JSTD25F/JSTD25H

Article no. 2TLA020007R6000/2TLA020007R6300 Two hand control unit with 2 Safeballs. Two Safeballs mounted on the ends of an aluminium profile, shielded by over hand guards. Replaces a traditional two hand device. Installed with the aid of grooves in the aluminium profile. Connection to an M12 connector underneath, JSTD25F with 5 pole M12 connection and JSHD25H with 8 pole M12 Connection. Can be equipped with an external emergency stop (SMILE) and an EDEN sensor for position control. Its low weight makes this particularly suitable for frequent repositioning.

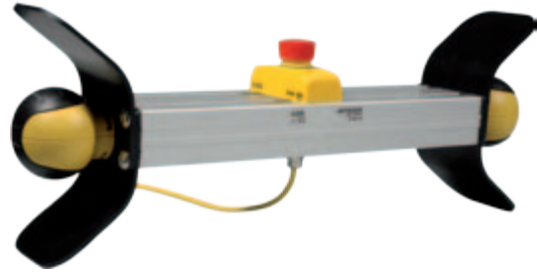

**JSTD25G** Article no. 2TLA020007R6200 Similar to JSTD25F but the dimensions additional equipment and type of connection can, to a large extent, be customised before delivery. Can also be equipped with doubled protection plates for use in particularly severe conditions.

## For mobile installation with a built-in Eden sensor

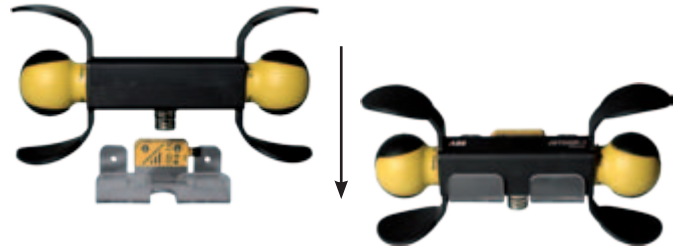

**JSTD25P-1** Article no. 2TLA020007R6500 Two hand control unit, portable. Two Safeballs mounted on the ends of an aluminium profile, shielded by over hand guards. With built-in Eva sensor for position control. Developed as a portable two hand device, where the response of the machine

to operation can vary at different operating stations, since each station can be connected separately. Connection via an 8+1 Zylin connector. Accessories are a connector, spiral cable with connector and suspension shelf. (article no. 2TLA020007R8000).

## Accessories - JSTD25

### JSTS31

Article no. 2TLA020007R4100 Stand with spacer ring for JSTD25 A-E (JSTS30 without spacer ring).



Height  
850-1100 mm

### JSM C5

Article no. 2TLA020007R0900 Angled ball joint for installation of a Safeball on a table or a steel housing.



### JSTK40S

Article no. 2TLA020007R6700 4 m long spiral cable for JSTD25P-1

### JSTK80S

Article no. 2TLA020007R6800 8 m long spiral cable for JSTD25P-1



## Connection example - JSTD25/A/B/D/E

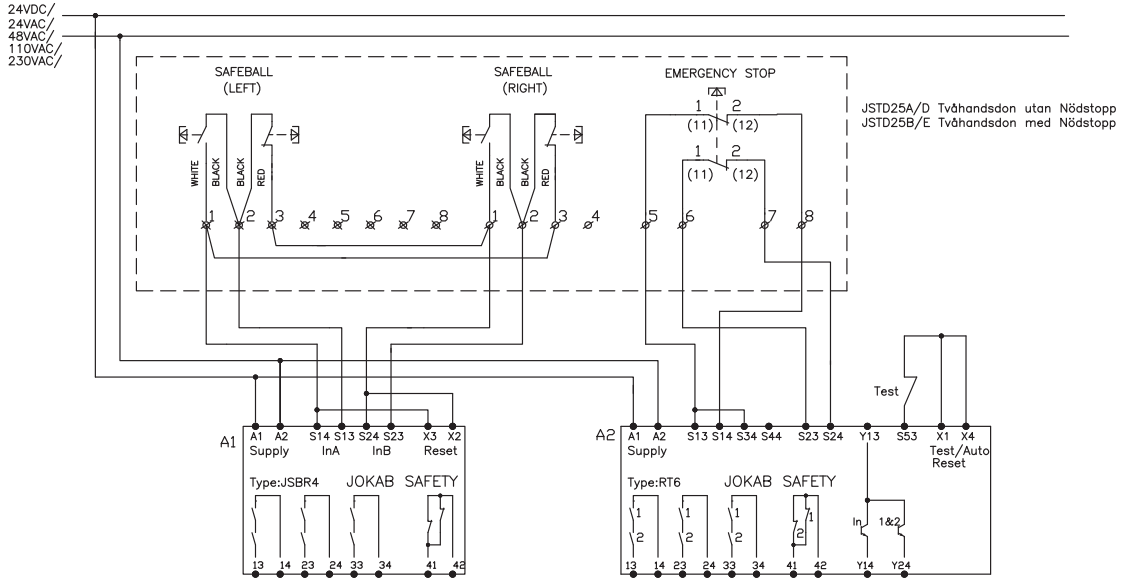

## Connection example - JSTD25F

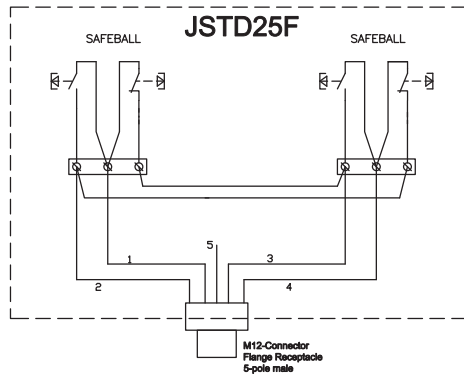

M12 5 Color-code  
(not always used, verify!)

- 1 Brun Brown Braun Marron
- 2 Vit White Weiss Blanc
- 3 Blå Blue Blau Bleu
- 4 Svart Black Schwartz Noir
- 5 Not connected

1 Dyn A out  
2 Pluto to evaluate A = OK, and test B (two inputs)  
3 Pluto to evaluate B = OK, and test A (two inputs)  
4 Dyn B out

According to standard Pluto Twohand1 block:  
I1: Right\_NO  
I2: Left\_NC  
I3: Right\_NC  
I4: Left\_NO

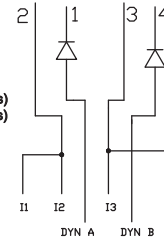
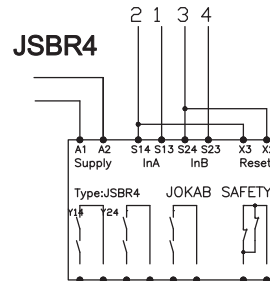

## Connection example - JSTD25H

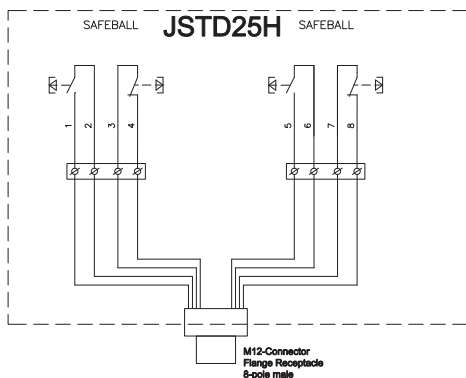

M12-03S  
Connector (plug) for self assembly, Female.  
As seen from cable side (inside).  
Ordered separately.

M12 8 Color-code  
(not always used, verify!)

- 1 Vit White Weiss Blanc
- 2 Brun Brown Braun Marron
- 3 Grön Green Grün Vert
- 4 Gul Yellow Gelb Jaune
- 5 Grå Grey Grau Gris
- 6 Rosa Pink Rosa Rose
- 7 Blå Blue Blau Bleu
- 8 Röd Red Rot Rouge

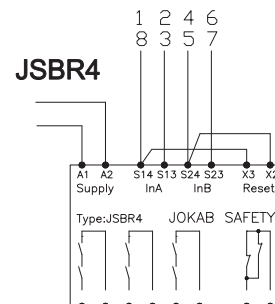
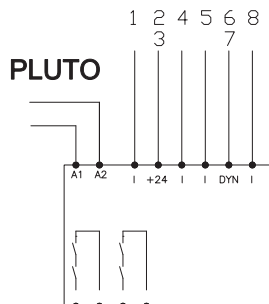

# Connection example - JSTD25P-1

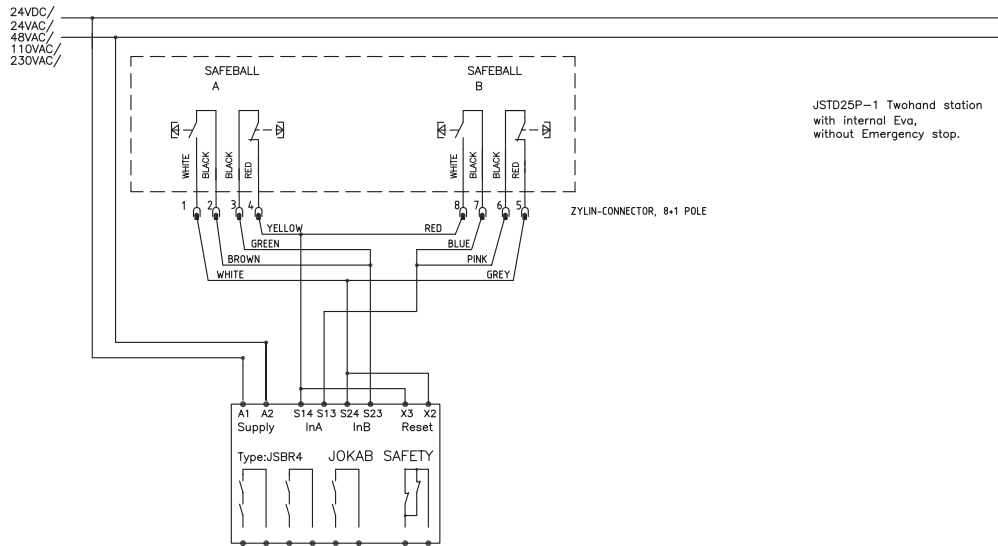

# Dimension sketch - JSTD25

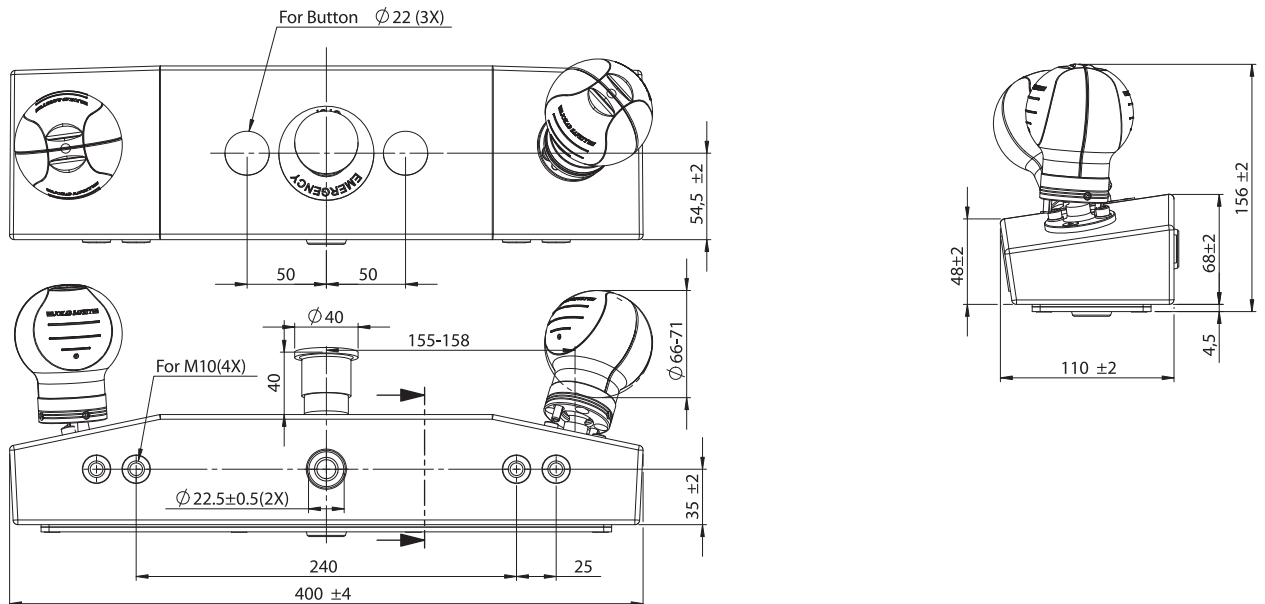
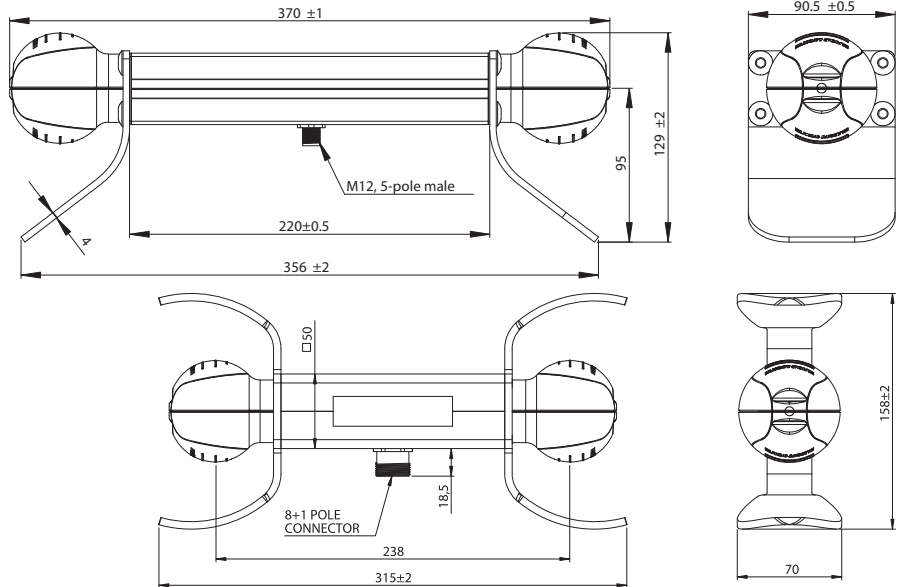
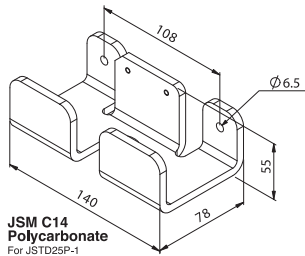
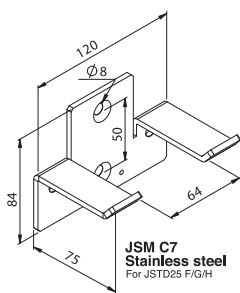

# Two hand device

# JSTD20



## Conventional Two hand device

The conventional JSTD20 Two hand device utilises a welded steel housing. Two operating pushbuttons are protected by over hand guards. Between these pushbuttons there is space for a emergency pushbutton and two extra controls or indication lamps. Below each of the operating pushbuttons is one normally open and one normally closed contact. To start and run the machine both pushbuttons must be activated within 0.5 seconds. If one or both pushbuttons are released a stop signal is given to the machine, and all contacts must return to their deactivated positions before a new start is allowed.

The design is robust and can withstand harsh environments and long use. The pushbuttons and contact blocks are simple to assemble for quick and easy installation. The device can be mounted directly on the machine, on the ABB Jokab Safety fencing system or on the JSTS30 floor mount. For use with portable Two hand devices the JSTS31 floor mount, which is provided with a spacer ring to fulfil the requirements of EN 574, is recommended. The JSTD20 is available with or without an emergency stop pushbutton.

## Highest level of safety

Correct connection to a ABB Jokab Safety JSBR4 safety relay or Pluto Safety PLC ensures the highest level of safety with dual and supervised safety function and requires input activation of both operating pushbuttons within 0.5 seconds

## Approvals



## JSTD20 for:

- Presses
- Punching machines
- Cutting machines
- Fixtures

## Features:

- Durable material
- With or without emergency stop pushbutton
- Fulfils requirements of EN 574
- Highest level of safety

(two hand device type III C in accordance with EN 574). If the emergency pushbutton is installed it should be provided with two normally closed contacts and be connected to a separate safety relay, e.g. from the RT series or Pluto.

## Why use a Two hand device?

A two hand device can be used when it is necessary to ensure that the operator is outside and must be prevented from reaching into the hazardous area. If the operator decides, after the start signal has been given to the machine, to make an 'after grasp' i.e. try to adjust the part that has been placed inside the machine, then a dual stop signal is given to the machine.

The new JSTD20 is equipped with a new type of large over hand guards in accordance with EN 574. These prevent unintended activation by for instance a knee or elbow.

A Two hand device only protects the operator using it. Large machines operated by several operators can be equipped with one control for each operator.

To calculate the correct safety distance, which depends on the machine's stopping time including the response time of the relay, the use of the ABB Jokab Safety Smart Stopping analyser is recommended.

Technical data - JSTD20	
<b>Manufacturer</b>	ABB AB/Jokab Safety, Sweden
<b>Article number/ ordering number</b>	2TLA020007R2000 JSTD20A 2TLA020007R2100 JSTD20B 2TLA020007R2200 JSTD20C
<b>Weight</b>	JSTD20: 6.4 Kg JSTS30: 20 Kg JSTS31: 23 Kg
<b>Colour</b>	Black housing, Black pushbut- tons, Black floor stand.
<b>Temperature</b>	-10°C...+70°C (Operating) -20°C to +70°C (storage)
<b>Safety level</b> EN ISO 13849-1 EN 954-1	Upp till kat. 4/PL e Upp till kat. 4
<b>Material</b>	Housing: 3mm Steel Gasket: Rubber Pushbuttons: Plastic
<b>Operating pushbuttons</b>	
Diameter	60 mm
Operating force	Approx. 9N
Operating distance	3.5±1 mm
Mechanical life	10 <sup>6</sup> operations
<b>Emergency pushbutton</b> (JSTD20B only)	
Diameter	40 mm
Operating force	40N
Mechanical life	3 x 10 <sup>5</sup> operations
Contacts	Mechanically separated contact blocks
<b>Operating pushbuttons</b>	1 NO + 1 NC
<b>Emergency pushbuttons</b>	2 x NC
<b>Isolation voltage</b>	690V rms
<b>Contact resistance</b>	20 mohm

<b>Rated current</b>	10A
<b>Utilisation categories</b>	AC 15 240V 3A DC 13 240V 0.27A
<b>Cabling</b>	screw clamp terminals, 1 or 2 wires with max. cross-section 2.5 mm <sup>2</sup> .
<b>Contact material</b>	silver alloy on brass
<b>Protection class:</b>	IP 65
<b>Conformity:</b>	EN 418, EN 574, EN 954-1, EN ISO 13849, EN 60947-1, EN 60947-5-1, EN 999

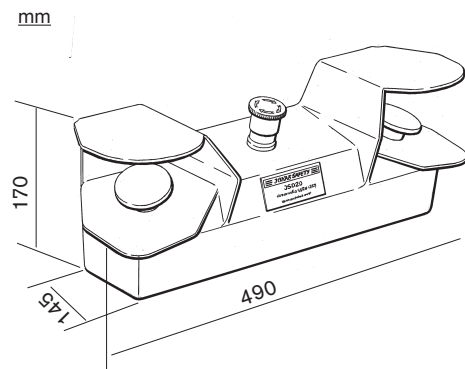

JSTD20A – Two hand device, without emergency stop  
JSTD20B – Two hand device, with emergency stop  
JSTD20C – Only housing, no buttons

### Connection example - JSTD20

The Two hand device is intended for use with ABB Jokab Safety's JSBR4 safety relay (or Pluto Safety PLC) to ensure the highest level of safety. The JSBR4 ensures that all contacts have returned to their deactivated positions before a new start is allowed. The safety relay also requires that all contacts are activated within 0.5 seconds. The JSBR4 gives a stop signal if one or both of the pushbuttons are released.

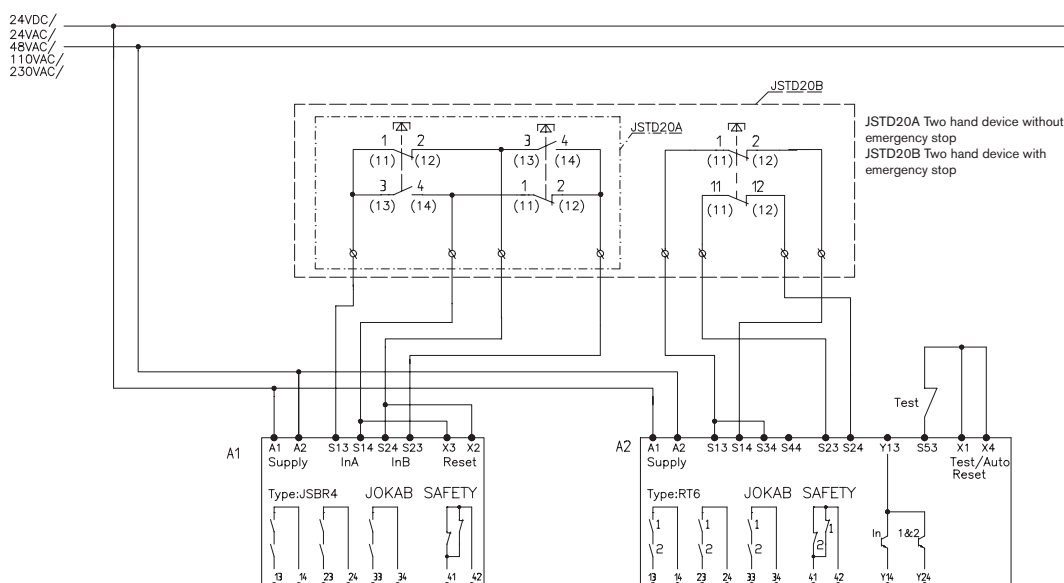

# Emergency stops

## and safety stops

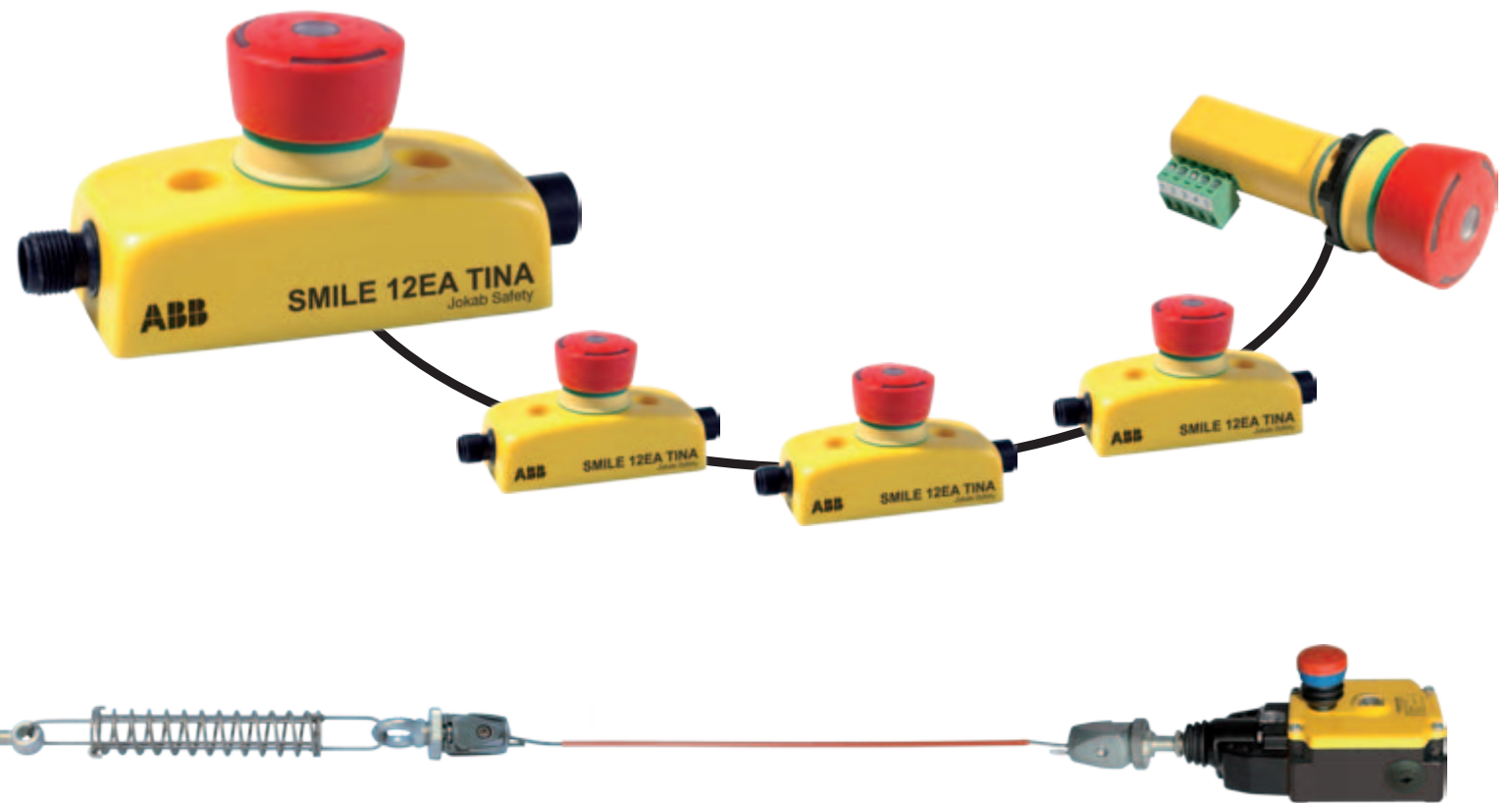



<b>Contents</b>	<b>Page</b>
<i>Why do you need an Emergency stop?</i> _____	<b>11:2</b>
<i>Emergency stop for enclosure installation – INCA 1</i> _____	<b>11:3</b>
<i>Emergency stop for enclosure installation – INCA 1 Tina</i> _____	<b>11:4</b>
<i>Emergency stop with LED – Smile</i> _____	<b>11:6</b>
<i>Emergency stop with LED – Smile Tina</i> _____	<b>11:10</b>
<i>Emergency stop with LED – Smile AS-i</i> _____	<b>11:14</b>
<i>Emergency stop Grab Wire Safety Switch Stop-Line</i> _____	<b>11:16</b>
<i>Safety stop Inca and Smile</i> _____	<b>11:20</b>
<i>Reset button Smile 11R</i> _____	<b>11:21</b>

Descriptions and examples in this book show how the products work and can be used. This does not mean that they can meet the requirements for all types of machines and processes. The purchaser/user is responsible for ensuring that the product is installed and used in accordance with the applicable regulations and standards. We reserve the right to make changes in products and product sheets without previous notice. For the latest updates, refer to [www.abb.com/lowvoltage](http://www.abb.com/lowvoltage). 2011.

# Why do you need an Emergency stop?

**So that anyone shall be able to stop a machine during a machine break-down or if someone is in danger.**

## How do I recognise an E-stop?

E-stop buttons shall according to relevant standards be red with a yellow background. An emergency stop grab wire shall be red for high visibility. A sign that indicates the location of the E-stop shall be green with a white picture and possibly with text in the local country's language.



## How shall an E-stop stop the machine?

An E-stop shall stop the machine as quickly as possible. To obtain a quick stop one either removes the power directly or one lets a frequency converter 'run down' and afterwards after a little delay, remove the power. An E-stop shall not create other hazards. Therefore a risk analysis must be made for the E-stop to be correctly connected.

From 2006/42/EC, clause 1.2.4.3

...

This device must:

- have clearly identifiable, clearly visible and quickly accessible control devices,
- stop the hazardous process as quickly as possible, without creating additional risks,
- where necessary, trigger or permit the triggering of certain safeguard movements.

...

## Requirements for E-stops are stated in the following standards and regulations

### 2006/42/EC The Machinery Directive

Clause 1.2.4.3 in Annex 1 gives requirements for the emergency stop function for new machines). See also clause 1.2.2 Control devices. (see chapter "Standard and Regulations")

### Council Directive 89/655/EEC (with amendments) concerning the minimum safety and health requirements for the use of work equipment by workers at work

Clause 2.4 gives the requirements for the emergency stop function for older machines. See also clause 2.1. (see chapter "Standard and Regulations")

### EN ISO 13850 Safety of machinery – Emergency stop – Principles for design

A harmonized standard that gives technical specifications for the requirements in the Machinery Directive. Could also be used for older machinery.

### EN 60204-1 Safety of Machinery - Electrical equipment of machines – Part 1: General requirements.

Harmonized standard that gives requirements for the electrical equipment of machinery including the emergency stop actuator/function. See clauses 9.2.2 and 9.2.5.4.2.

# Emergency stop for enclosure installation

# INCA 1



## Approval:



## Application:

Emergency push button for installation in cabinets

## Advantages:

- Terminal blocks
- Emergency push button up to cat. 4/PL e acc. to EN ISO 13849-1
- Only 53 mm's construction depth
- With LED info in print
- Push button IP65, connector IP20
- Available as safety stop (black push button)

INCA 1 is an emergency stop designed for installation in 22.5 mm holes on cabinets. "INCA 1" has potential free contacts for connection to safety relays. The connection is made in cabinets via a removable terminal which also have excellent measuring points. Inca 1 is also available with a black pushbutton and used as a safety stop. See section on safety stops.

In the emergency stop button there is a LED that displays current status on:

- Green = everything ok
- Red = this emergency push button has been pressed
- Off = a unit earlier in the circuit is affected

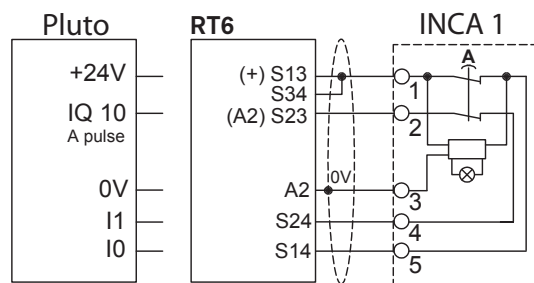

Yellow front ring and emergency stop signs for emergency stop.

# Emergency stop for enclosure installation

# INCA 1 Tina



## Approval:



## Application:

Emergency push button for installation in cabinets

## Advantages:

- Terminal blocks
- Emergency push button up to cat. 4/PL e acc. to EN ISO 13849-1
- Only 53 mm's construction depth
- With LED info in push button
- Info output (Inca1 Tina)
- Push button IP65, connector IP20
- Available as safety stop (black push button)

INCA 1 Tina is an emergency stop designed for installation in 22.5 mm holes in equipment cabinets. In addition to the INCA 1 version, "INCA 1 Tina" is also available with electronic adjustment of the dynamic safety loop for connection to the Vital and Pluto units. The connection is made in equipment cabinets via a removable terminal block which also has marked measuring points. Inca 1 Tina is also available with black push button and is used in this case as a safety stop. See section on safety stops.

The emergency stop button has a LED that displays the current status:

- Green = everything is OK
- Red = this emergency stop has been pressed.
- Flashing red/green = a protection device earlier in the loop has been actuated.

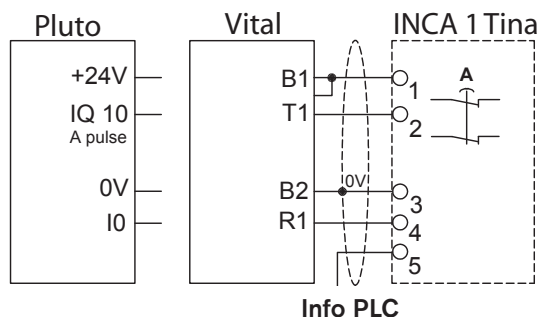

Yellow front ring and emergency stop signs for emergency stop.

Technical data - INCA 1/INCA 1 Tina	
<b>Manufacturer:</b>	ABB AB/Jokab Safety, Sweden
<b>Article no./Ordering data:</b> INCA 1 INCA 1 Tina	2TLA030054R0100 2TLA030054R0000
<b>Impact resistance (half sinusoidal)</b>	Max. 150m/s <sup>2</sup> , pulse width 11 ms, 3-axis, acc. to EN IEC 60068-2-27
<b>Vibration resistance (sinusoidal)</b>	Max. 50 m/s <sup>2</sup> at 10 Hz... 500 Hz, 10 cycles, 3 axis, acc. to EN IEC 60068-2-6
<b>Climate resistance</b> Damp heat, cyclical  Damp heat, sustained  Dry heat  Cooling  Salt mist	96 hours, +25 °C / 97%, +55 °C / 93 % relative humidity, as per EN IEC 60068-2-30 56 days, +40 °C / 93 % relative humidity, as per EN IEC 60068-2-78 96 hours, +70 °C, as per EN IEC 60068-2-2 96 hours, -40 °C, as per EN IEC 60068-2-1 96 hours, +35 °C in a chemical solution with NaCl as per EN IEC 60068-2-11
<b>Level of safety:</b> Cat. 4/PL e Category 4 SIL 3 SIL 3	EN ISO 13849-1 EN 954-1 EN 62061 IEC/EN 61508-1...7
<b>PFH<sub>d</sub>:</b> INCA 1 INCA 1 Tina:	PFH <sub>d</sub> : 1,60×10 <sup>-10</sup> PFH <sub>d</sub> : 4.66×10 <sup>-9</sup>
<b>Colour:</b>	Yellow, red and black
<b>Weight:</b>	Approx. 45 grams
<b>Size:</b>	See drawing
<b>Material:</b>	Polyamide PA66, Macromelt, Polybutylenterephthalate PBT UL 94 V0
<b>Temperature:</b>	-10°C to +55°C (operation), -30°C to +70°C (storage)
<b>Enclosure classification</b>	Print: IP 65, Connector: IP20
<b>Installation:</b>	22,5 mm
<b>Emergency stop LEDs:</b>	<b>INCA 1:</b> Green: Safety device OK. Not lit: A unit earlier in the circuit is affected. Red: This emergency stop has been pressed. <b>INCA 1 Tina:</b> Green: Safety device OK, safety circuit OK Flashing: Safety device OK, safety circuit previously broken. Red: This button is pressed in, and the safety circuit is broken.

<b>Operating voltage (LED):</b>	<b>INCA 1:</b> 24 VDC <b>INCA 1 Tina:</b> 24VDC +15% -25%
<b>Current consumption (LED):</b>	<b>INCA 1:</b> 15 mA <b>INCA 1 Tina:</b> 47 mA
<b>Emergency stop button Operating force:</b>	22 ± 4 N
<b>Operating movement:</b>	Approx. 4 mm to locked position
<b>Contact material:</b>	Gold-plated silver alloy
<b>Minimum current:</b>	<b>INCA 1:</b> 10 mA, 10 VDC/10 VAC <b>INCA 1 Tina:</b> —
<b>Maximum current:</b>	<b>INCA 1:</b> 2 A 24 VDC, 1A 125 VAC <b>INCA 1 Tina:</b> —
<b>Mechanical life:</b>	> 50 000 operations
<b>Standards:</b>	EN 60204, EN 60947-5-1 & -5 EN ISO 13850
<b>Accessories:</b> Front ring yellow for INCA Emergency stop sign S D F, 22,5mm Emergency stop sign E FT, 22,5mm	2TLA030054R0400  2TLA030054R0500  2TLA030054R0600
<b>Conformity:</b>	2006/42/EG EN 954-1, EN ISO 13849-1, EN 62061, EN 60204-1, EN 61496-1, IEC 60664-1, EN 61000-6-2, EN 61000-6-4, EN 60947-5-1, EN 1088

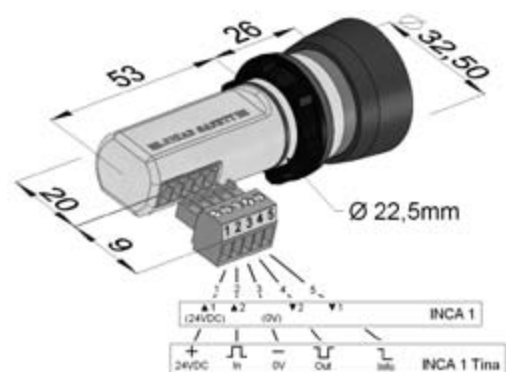

# Emergency stop with indication

# Smile



## Approvals:



## Application:

To stop a machine or a process

## Features:

- Emergency push button up to cat. 4/PL e acc. to EN ISO 13849-1
- With LED info in push button
- Robust
- Push button IP 65, housing IP67
- Available as safety stop (black push button)

## Smile - small and cost effective E-stop

In order to fulfil the need for a small and easy to install E-stop, Smile has been developed. The size of the device makes it possible to be installed wherever you want. With M12 connection/s or cable and centralised mounting holes Smile is very easy to install, especially on aluminium extrusions. Smile is available for E-stops in both dynamic and static safety circuits i.e. for interfacing to Vital/Pluto and Safety relays. Each version is available with either one or two M12 connections or cable. At the top of Smile, a LED shows the current status as: green = protection OK, red = this emergency stop has been pressed and if the LED is off, an emergency stop earlier in the loop has been actuated. Smile is also available with black push button and is used as a safety stop. See section on safety stops.

### Smile emergency stop has six different variants:

1. Smile 10EA has a 1 m cable connected through the base of the unit.
2. Smile 10EK has four 1 m short connecting leads through the base of the unit. No LED.
3. Smile 11EA has a five-pole M12 connector on one end of the unit.
4. Smile 12EA has two five-pole M12 connectors, one on each end of the unit.
5. Smile 11EAR has one 5-pole M12 connector at one end.
6. Smile 12EAR has two 5-pole M12 connectors at each end.

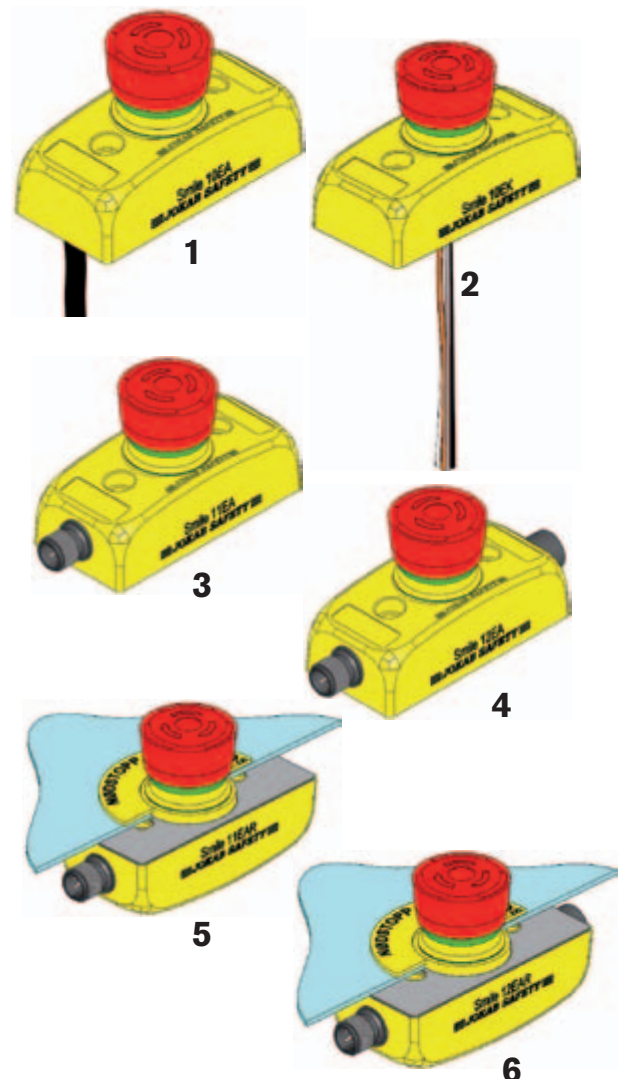



## Connection examples – Smile

**Smile 10EA** can be connected to either Pluto or a safety relay. *Single channel* example with LED indication. Safety category 1. The connection cable exits from underneath the unit.

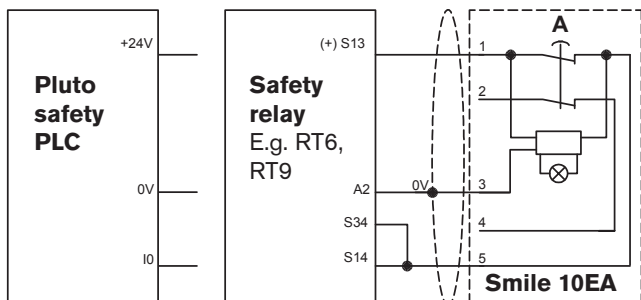

**Smile 10EA** can be connected to either Pluto or a safety relay. *Two channel* example with LED indication. Safety circuit category 4.

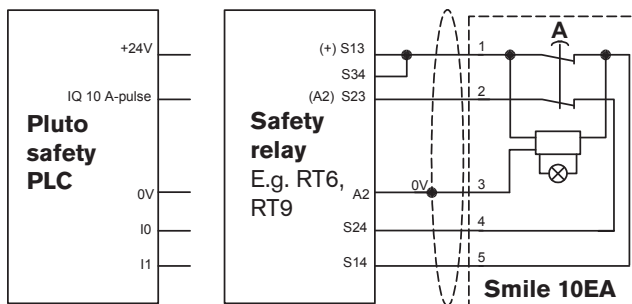

**Smile 11EA** can be connected to either Pluto or a safety relay. *Single channel* example with LED indication. Safety category 1. Connection via M12 connector.

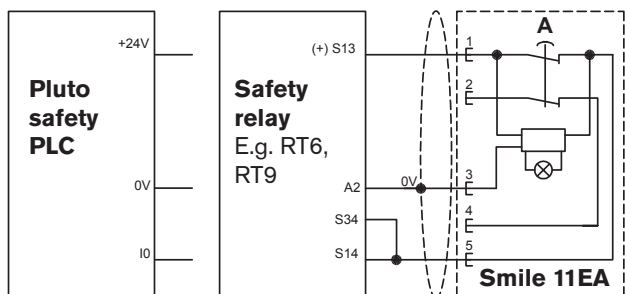

**Smile 11EA** can be connected to either Pluto or a safety relay. *Two channel* example with LED indication. Safety circuit category 4. Connection via M12 connector.

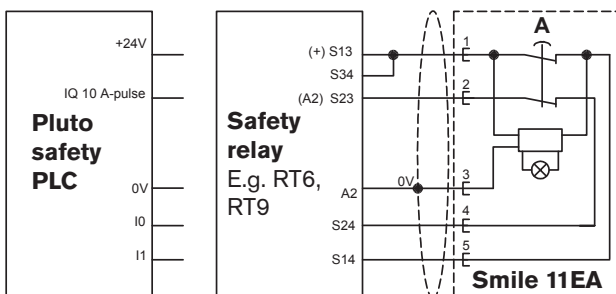

**Smile 12EA** can be connected to either Pluto or a safety relay. *Single channel* example with LED indication. Safety category 1. Connection via M12 connector + termination connector.

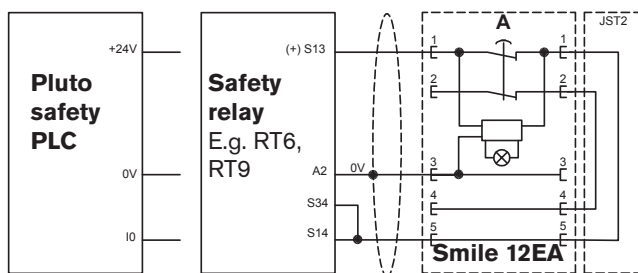

**Smile 12EA** can be connected to either Pluto or a safety relay. *Two channel* example with LED indication. Safety circuit category 4. Connection via M12 connector + termination connector.

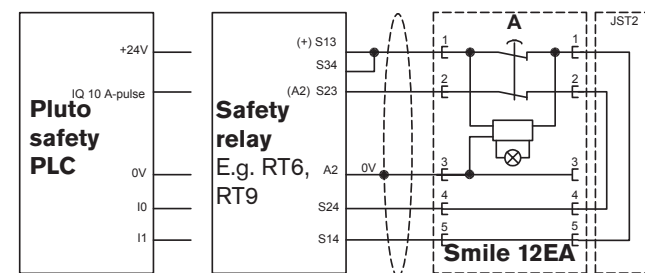

**Smile 12EA** can be connected to either Pluto or a safety relay. *Two channel* serial connection example with LED indication. Safety circuit category 3. Connection via M12 connectors. Connection is made here without a termination device for Smile 12EA (C), this unit is reconnected to the Pluto/safety relay via a separate cable. You can also use JST2 as a termination device after Smile 12EA (C).

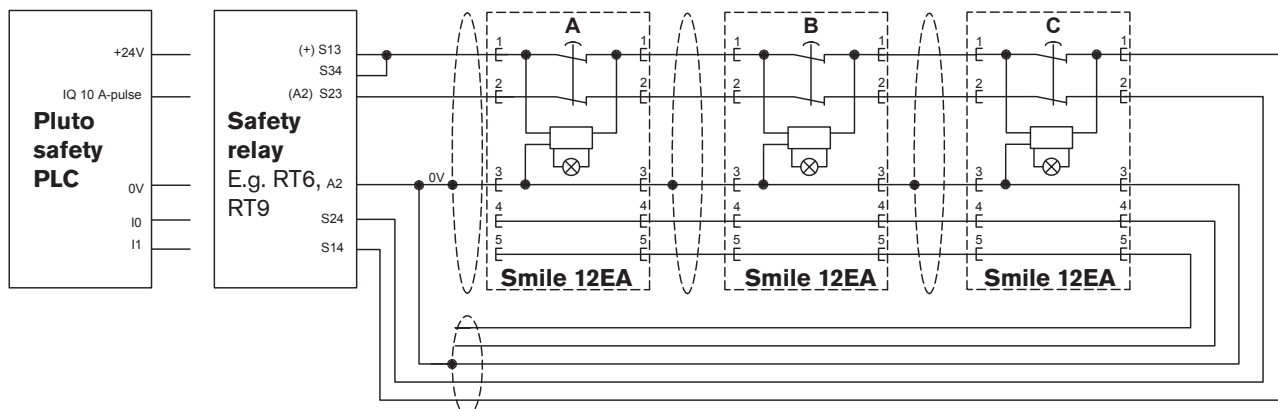

## Connection examples – Smile

**Smile 12EA and 11EA** can be connected to either Pluto or safety relay. *Two channel* example with LED indication. Safety circuit category 3. Connection via M12 connectors. Note that there is no termination connector as the Smile 11EA (C) completes the circuit without the need for a termination connector (JST2) or return cable.

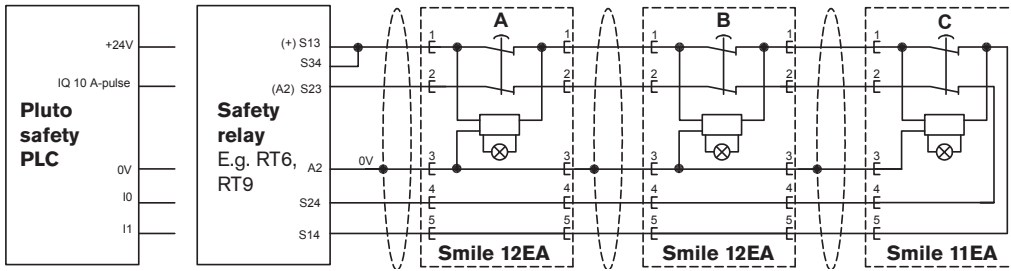

### E-Stop Button status LED Indication

A	B	C		A	B	C
R	R	R	↔	G	G	G
R	R	D	↔	G	G	Rd
R	D	R	↔	G	Rd	B
R	D	D	↔	G	Rd	B
D	R	R	↔	Rd	B	B
D	R	D	↔	Rd	B	B
D	D	R	↔	Rd	B	B
D	D	D	↔	Rd	B	B

The table shows the LED indication status of the E-Stop buttons from the example shown in above example.

A = Smile 12EA  
 B = Smile 12EA  
 C = Smile 11EA  
 R = Released  
 D = Depressed  
 G = Green light from the top of the button  
 Rd = Red light from the top of the button  
 B = Blank, no light



Termination device JST2

**Smile 10EA/11EA/12EA** are like any other emergency stops when 0V to the LED indication is not connected. This means that any suitable Safety PLC or safety relay can be used. If the LED indication is used, the voltage between Pin 1(+) and Pin 3 (-) should be between 19.2 – 28.8 VDC. The following examples show connections to Safety PLC and Safety relay.

### Single channel PLC connection

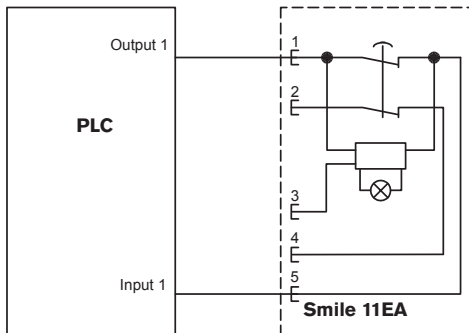

### Two channel Safety relay connection

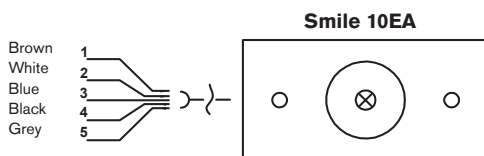
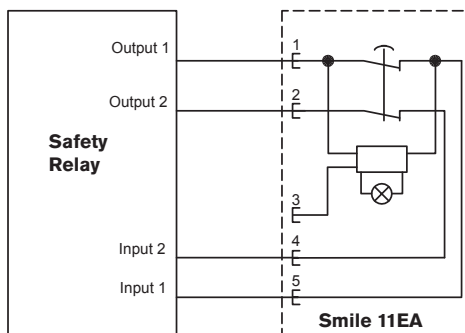

Smile 10EA

The cable is connected to Smile 10EA via the lid at the back.

1. Input 1
2. Input 2
3. 0 VDC (to be connected only if LED indication is required)
4. Output 2
5. Output 1

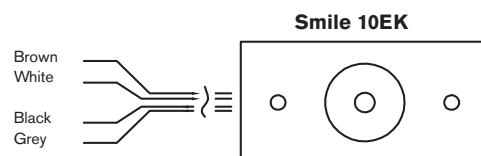

Smile 10EK

The leads are connected to Smile 10EK via the lid at the back. No LED connection.

- Brown Input 1
- White Input 2
- Black Output 2
- Grey Output 1

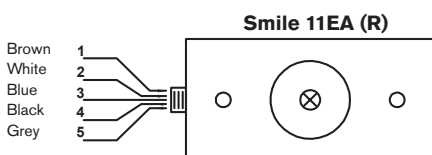

Smile 11EA (R)

1. Input 1
2. Input 2
3. 0 VDC (to be connected only if LED indication is required)
4. Output 2
5. Output 1

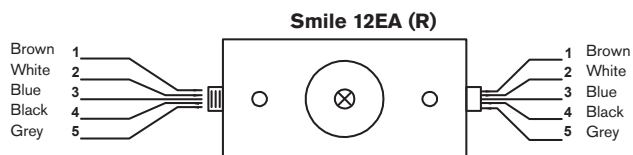

Smile 12EA (R)

1. Input 1
  2. Input 2
  3. 0 VDC (to be connected only if LED indication is required)
  4. Output 2, feedback
  5. Output 1, feedback
1. Output 1
  2. Output 2
  3. 0 VDC
  4. Input 2, feedback
  5. Input 1, feedback

Technical data – Smile	
<b>Manufacturer:</b>	ABB AB/Jokab Safety, Sweden
<b>Article number/ ordering data:</b>	
Smile 10EA with 1 m cable	2TLA030051R0400
Smile 10EK with short connecting leads (No LED connection)	2TLA030051R0600
Smile 11EA with M12 male connector	2TLA030051R0000
Smile 12EA with male and female M12 connectors	2TLA030051R0200
Smile 11EAR	2TLA030051R0100
Smile 12EAR	2TLA030051R0300
JST2 termination for Smile 12.	2TLA030051R1300
<b>Note.</b> There are versions for dynamic technology (with Tina).	
<b>Impact resistance (half sinusoidal)</b>	max. 150 m/s <sup>2</sup> , pulse width 11 ms, 3-axis, as per EN IEC 60068-2-27
<b>Vibration resistance (sinusoidal)</b>	max. 50 m/s <sup>2</sup> at 10 Hz, 10 cycles, 3-axis, as per EN IEC 60068-2-6
<b>Climate resistance</b>	
Damp heat, cyclical	96 hours, +25 °C / 97%, +55 °C / 93 % relative humidity, as per EN IEC 60068-2-30
Damp heat, sustained	56 days, +40 °C / 93 % relative humidity, as per EN IEC 60068-2-78
Dry heat	96 hours, +70 °C, as per EN IEC 60068-2-2
Cooling	96 hours, -40 °C, as per EN IEC 60068-2-1
Salt mist	96 hours, +35 °C in a chemical solution with NaCl as per EN IEC 60068-2-11
<b>Level of safety:</b> IEC/EN 61508-1...7	SIL 3
<b>PFH<sub>d</sub>:</b>	1,60E-10
<b>Colour:</b>	Yellow, red and black
<b>Weight:</b>	Approx. 65 grams
<b>Size:</b>	Length: 84 mm + M12 contact(s) (12.5 mm each) Width: 40 mm Height: 52 mm
<b>Material:</b>	Polyamide PA66, Macromelt, Polybutylenterephthalate PBT, Polypropylene PP, UL 94 V0
<b>Ambient temperature:</b>	-10°C to +55°C (operation), -30°C to +70°C (stock)
<b>Protection class:</b>	IP 65

<b>Mounting:</b>	Two M5 recessed hexagon head screws, L ≥25 mm. Hole cc: 44 mm
<b>LED on E-Stop:</b>	Green: Safety device ok, Safety circuit closed Off: Safety circuit broken (When an E-Stop is depressed all following units in the circuit lose the LED function). Red: Safety device actuator depressed and Safety circuit broken.
<b>Input voltage (LED):</b>	17-27 VDC ripple ±10% (LED supply voltage)
<b>Current consumption (LED):</b>	15 mA
<b>E-Stop button Actuating force:</b>	22 ± 4 N
<b>Actuator travel:</b>	Approx. 4 mm to latch
<b>Material, contacts:</b>	Silver alloy gold plated
<b>Min current:</b>	10 mA 10 VDC/ 10 VAC
<b>Max current:</b>	2 A 24 VDC, 1 A 125 VAC
<b>Life, mechanical:</b>	> 50 000 operationer
<b>Accessories:</b>	
Emergency stop button S D F, 32,5mm	2TLA030054R0700
Emergency stop button E F T, 32,5mm	2TLA030054R0800
<b>Conformity:</b>	EN ISO 13850, EN 60204, EN 60947-5-1 & -5



Sign for emergency stop

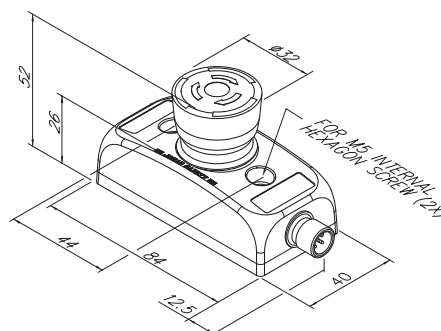

# Emergency stop with indication

# Smile Tina



## Smile Tina - small and cost effective E-stop

In order to fulfil the need for a small and easy to install E-stop, Smile has been developed. The size of the device makes it possible to be installed wherever you want. With M12 connections or cable and centralised mounting holes Smile is very easy to install, especially on aluminium extrusions. Smile is available for E-stops in both dynamic and static safety circuits i.e. for interfacing to Vital system/Pluto safety PLC and Safety relays. Each version is available with either one or two M12 connections or cable. Two M12 connectors are used to enable the connection of E-stops in series, which is often used with dynamic safety circuits fulfilling safety category 4. In the top of the Smile Tina E-stop unit, LEDs show the actual status according to the dynamic system:

Green = everything is OK, Red = E-stop activated.

Flashing Red/Green = Stop activated from another preceding device. Smile is also available with black push button and used as a safety stop. See section on safety stops.

### The Smile Tina emergency stop is available in four versions:

1. Smile 10EA Tina has a 1 m cable connected via the base of the unit.
2. Smile 11EA Tina has a five-pole M12 connector on the end of the unit for connecting the ABB Jokab Safety cable.
3. Smile 12EA Tina has two five-pole M12 connectors, one on each end of the unit for connecting the ABB Jokab Safety cable.
4. Smile 11EAR Tina has one 5-pole M12 connector at one end for connection of cable from ABB Jokab Safety.

## Approvals:



## Application:

To stop a machine or a process

## Features:

Emergency push button up to cat. 4/PL e acc. to EN ISO 13849-1

Light grids, emergency stop and Eden in the same safety loop together with Vital or Pluto gives cat. 4/PL e acc. to EN ISO 13849-1

With LED indication on push button

Robust

Info-signal from each emergency stop

Push button IP 65, housing IP67

Available as safety stop (black push button)

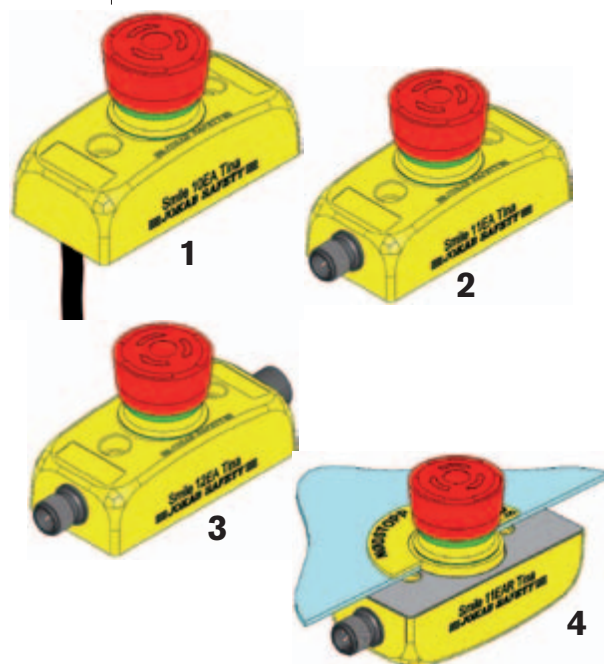

## Connection examples – Smile Tina

**Smile 10EA Tina** can be connected to either a Pluto or Vital system. Safety circuit category 4 with LED indication/information. The connection cable exits from underneath the unit.

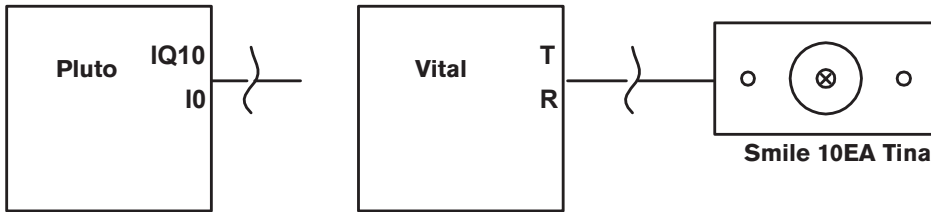

**Smile 11EA Tina** can be connected to either a Pluto or Vital system. Safety circuit category 4 with LED indication/information. Connection via M12 connectors. The circuit below shows three Smile 11EA Tina units connected *in series* via connection terminals in the electrical cabinet.

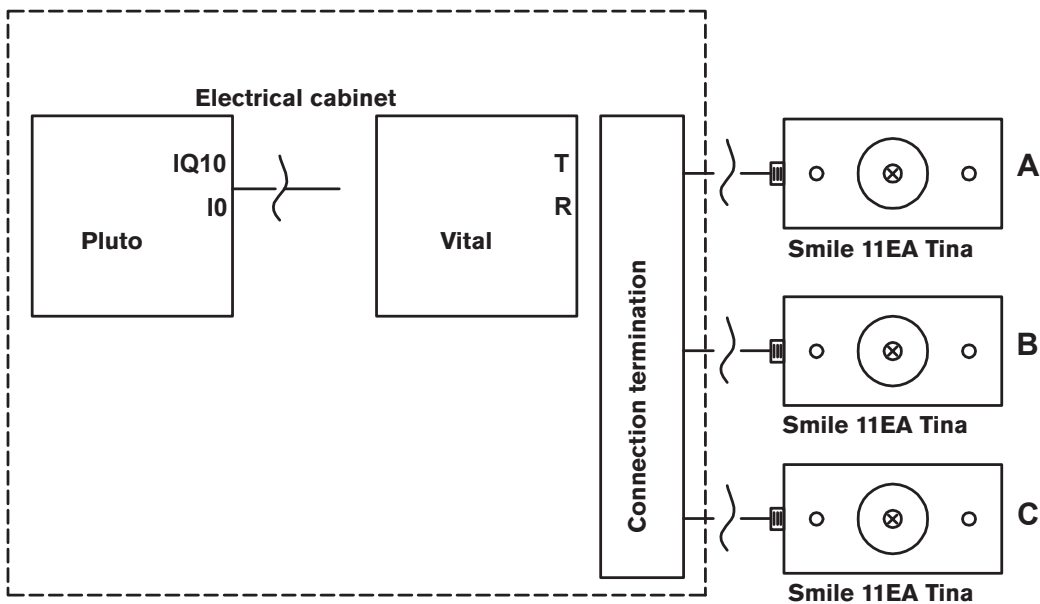

**Smile 11EA Tina** can be connected to either a Pluto or Vital system. Safety circuit category 4 with LED indication/information. Connection via M12 connectors. The circuit below shows three Smile 11EA Tina units and one Eden connected *in series* via a Tina 4A connection block.

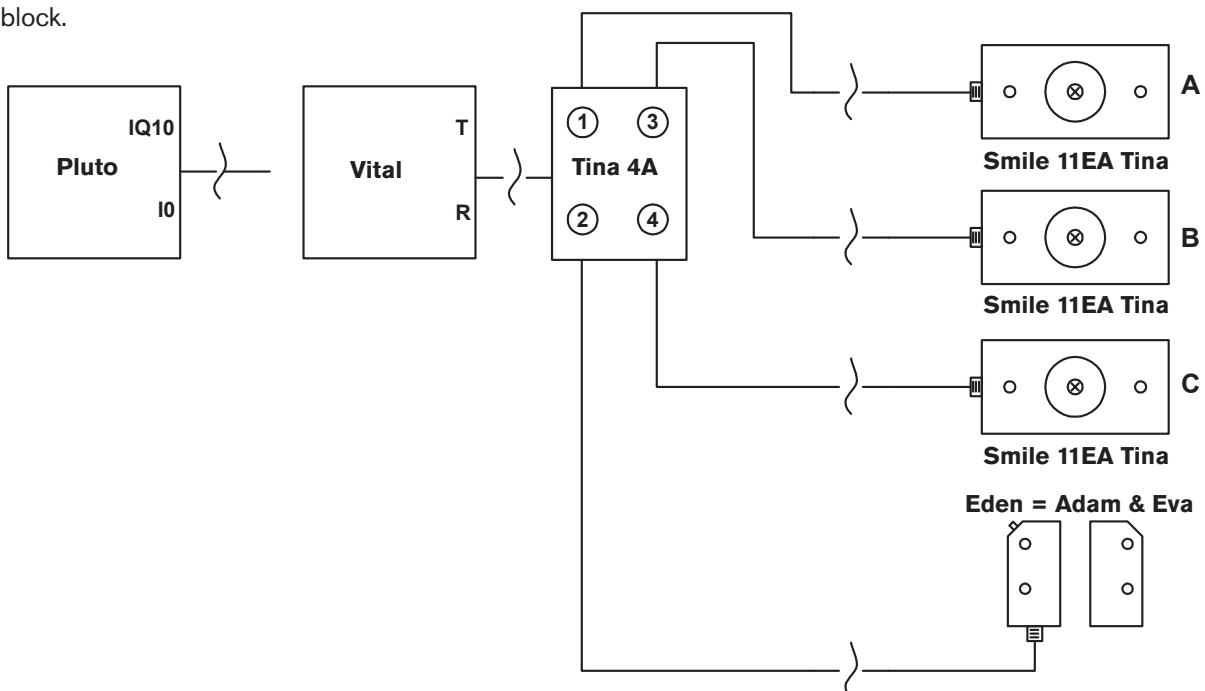

## Connection examples – Smile Tina

### E-Stop Button status Information output signal

A	B	C		A	B	C
R	R	R	↔	H	H	H
R	R	D	↔	H	H	L
R	R	R	↔	H	L	H
R	R	D	↔	H	L	L
D	R	R	↔	L	H	H
D	R	D	↔	L	H	L
D	D	R	↔	L	L	H
D	D	D	↔	L	L	L

The table shows the information output signal status from each of the Smile 11EA Tina units in the previous connection examples.

In the example showing connection with an Eden sensor, the Eden status information signal acts in the same way as the Smile Tina 11EA units.

The status information signal can be connected to e.g. PLC input.

**Note.** The information signal must not be used as a safety signal. The signal should only be used to indicate the status of connected devices.

A = Smile 11 EA Tina  
B = Smile 11 EA Tina  
C = Smile 11 EA Tina  
R = Released

D = Depressed  
H = High (i.e. supply voltage)  
L = Low (= 0 VDC)

**Smile 12EA** can be connected to either a Pluto or Vital system. Safety circuit category 4 with LED indication/information. Connection via M12 connectors. The last Smile 12 EA Tina unit feeds the dynamic signal back to the Pluto/Vital.

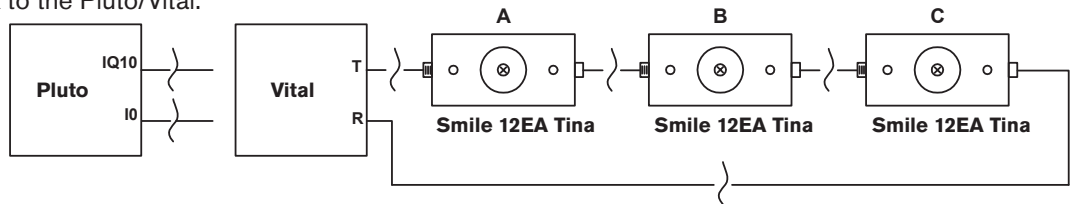

### E-Stop Button status LED Indication

A	B	C		A	B	C
R	R	R	↔	G	G	G
R	R	D	↔	G	G	Rd
R	D	R	↔	G	Rd	F
R	D	D	↔	G	Rd	Rd
D	R	R	↔	Rd	F	F
D	R	D	↔	Rd	F	Rd
D	D	R	↔	Rd	Rd	F
D	D	D	↔	Rd	Rd	Rd

The table shows the LED indication status of the E-Stop buttons in the previous connection examples, where three Smile 10 EA, Smile 11EA or 12EA Tina units are connected in series.

A = Smile 10/11/12 EA Tina  
B = Smile 10/11/12 EA Tina  
C = Smile 10/11/12 EA Tina  
R = Released  
D = Depressed  
G = Green light from the top of the button

Rd = Red light from the top of the button  
F = Flashes between green and red light

**Smile 12EA** can be connected to either a Pluto or Vital system. Safety circuit category 4 with LED indication/information. Connection via M12 connectors. The circuit shows two Smile 12EA Tina's, one Eden sensor and one Focus Light Curtain connected *in series*.

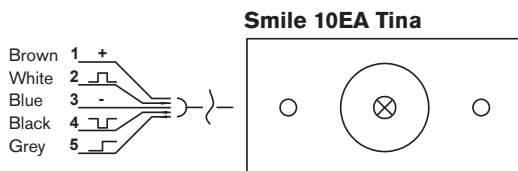
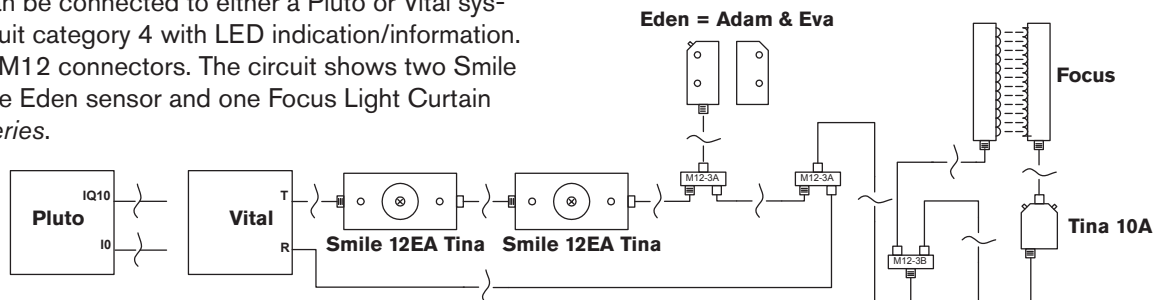

1. Input voltage, 17-27 VDC ripple +/- 10%
2. Dynamic input signal
3. 0 VDC
4. Dynamic output signal
5. Information output

The connection cable is connected to the Smile 10EA Tina unit via the back panel.

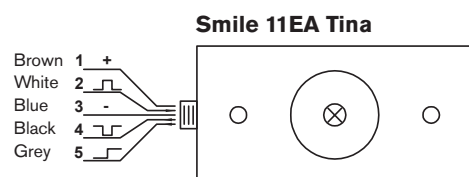

1. Input voltage, 17-27 VDC ripple +/- 10%
2. Dynamic input signal
3. 0 VDC
4. Dynamic output signal
5. Information output

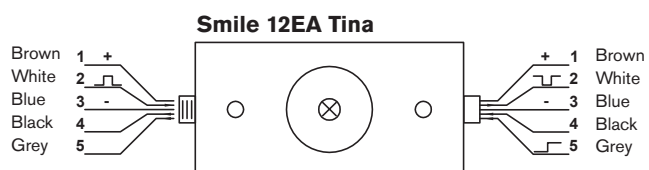

1. Input voltage, 17-27 VDC ripple +/- 10%
  2. Dynamic input signal
  3. 0 VDC
  4. Not used
  5. Not used
1. Output voltage to next unit
  2. Dynamic output signal (To next Smile or to Pluto or Vital system)
  3. 0 VDC
  4. Not used
  5. Information output



Technical data – Smile Tina	
<b>Manufacturer:</b>	ABB AB/Jokab Safety, Sweden
<b>Article number/ ordering data:</b>	
Smile 10EA Tina with 1 m connection cable	2TLA030050R0400
Smile 11EA Tina with M12 male connector	2TLA030050R0000
Smile 12EA Tina with male and female M12 connectors	2TLA030050R0200
Smile 11EAR Tina	2TLA030050R0100
Note. There are versions for use with relay technology (without Tina).	
<b>Impact resistance (half sinusoidal)</b>	max. 150 m/s <sup>2</sup> , pulse width 11 ms, 3-axis, as per EN IEC 60068-2-27
<b>Vibration resistance (sinusoidal)</b>	max. 50 m/s <sup>2</sup> at 10 Hz, 10 cycles, 3-axis, as per EN IEC 60068-2-6
<b>Climate resistance</b>	
Damp heat, cyclical	96 hours, +25 °C / 97%, +55 °C / 93 % relative humidity, as per EN IEC 60068-2-30
Damp heat, sustained	56 days, +40 °C / 93 % relative humidity, as per EN IEC 60068-2-28
Dry heat	96 hours, +70 °C, as per EN IEC 60068-2-2
Cooling	96 hours, -40 °C, as per EN IEC 60068-2-1
Salt mist	96 hours, +35 °C in a chemical solution with NaCl as per EN IEC 60068-2-11
<b>Level of safety:</b> IEC/EN 61508-1...7	SIL 3
<b>PFH<sub>d</sub>:</b>	4,66E-09
<b>Colour:</b>	Yellow, red and black
<b>Weight:</b>	Approx. 65 grams
<b>Size:</b>	Length: 84 mm + M12 contact(s) (12.5mm each) Width: 40 mm Height: 52 mm
<b>Material:</b>	Polyamid PA66, Macromelt, Polybutylenterephthalate PBT, Polypropylen PP, UL 94 V0
<b>Ambient temperature:</b>	-10°C to +55°C (operation) -30°C to +70°C (stock)
<b>Protection class:</b>	IP 65
<b>Mounting:</b>	Two M5 hexagon socket screws, L ≥25 mm. Hole centres: 44 mm

<b>LED on E-Stop:</b>	Green: Safety device OK, Safety circuit OK Flashing: Safety device OK, safety circuit broken. Red: Breaks in safety device and safety circuit
<b>Time delay:</b>	1:1.5 (Two Smile units are equal to three Edens in time delay)
<b>Input voltage:</b>	17-27 VDC ripple ±10%
<b>Current consumption:</b>	47 mA (57mA with max. current from information output)
<b>Current from information output:</b>	10 mA max
<b>E-Stop button Actuating force:</b>	22±4 N
<b>Actuator travel:</b>	Approx. 4 mm to latch
<b>Material, contacts:</b>	Silver alloy gold plated
<b>Life, mechanical:</b>	> 50 000 operations
<b>Accessories:</b>	
Emergency stop sign S D F, 32.5mm	2TLA030054R0700
Emergency stop sign E F T, 32.5mm	2TLA030054R0800
<b>Conformity:</b>	EN ISO 13850, EN 60204, EN 60947-5-1 & -5



Sign for emergency stop

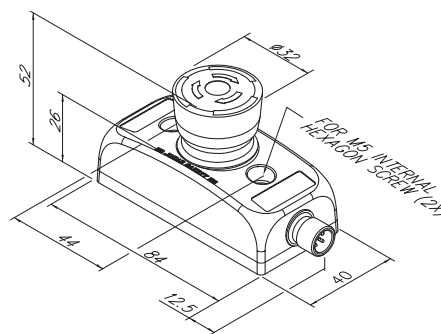

# Emergency stop with indication

# Smile AS-i

## Approvals:



## Application:

To stop a machine or a process

Safe input node in AS-i systems

## Features:

Emergency push button up to cat. 4/PL e acc. to EN ISO 13849-1

Simple connection to AS-i bus

With LED indication on push button and AS-i status indication

Robust

Push button IP 65, housing IP67

Available as safety stop (black push button)



Smile 11EA AS-i is an emergency stop with a built-in dual channel safe AS-i input node. The AS-i bus and the safety around it is specified by the two organisations "AS-International Association" and "AS-Interface Safety at Work", and is described in publications such as "AS-Interface The Automatic Solution".

Smile 11EA AS-i is supplied with 30 V DC from the AS-i bus. The recommended connection to the AS-i bus is made via a flat cable terminal to M12 (see Figure), which makes it possible to quickly and easily connect the device to the yellow AS-i cable.

Smile AS-i can also be connected directly to the AS-i bus using only two conductors (pins 1 and 3 on the unit's M12 contact). Smile is also available with black push button and is used in this case as a safety stop. See section on safety stops.



1  
2  
3  
4  
5  
6  
7  
8  
9  
10  
11  
12  
13  
14

Technical data – Smile AS-i	
<b>Manufacturer:</b>	ABB AB/Jokab Safety, Sweden
<b>Article number/ ordering data:</b> Smile 11EA AS-i	2TLA030052R0000
<b>AS-i data</b> AS-i profile Addressing Node address on delivery Response time across the AS-i bus	S-7.B.0 M12-contact 0 5 ms (+ response time for safety monitor)
<b>Pin configuration</b> (1) (2) (3) (4) (5)	AS-i + Not used AS-i – Not used Not used
<b>Voltage supply</b> Output voltage Total current consumption	30 V DC from the AS-i bus. Tolerance 26.5 – 31.6 V DC. < 60 mA
<b>General</b> Enclosure protection class Ambient temperature Dimensions Colour Actuating force Actuating movement Mechanical life	IP65 -25...+50°C 52 x 40 x 84 (+12,5 mm M12 contact) (H x B x D) Base: Yellow Emergency stop button (Smile 11EA AS-i): Red Safe stop button (Smile 11SA AS-i): Black 22 ±4 N Ca 4 mm till lås > 50 000 operationer
<b>PFH<sub>d</sub></b>	6,95x10 <sup>-9</sup>
<b>Safety/Harmonised standards</b> IEC/EN 61508-1..7 EN 62061 EN ISO 13849-1 EN 60947-5-1 & -5 EN ISO 13850:2008 Certification	SIL3, PFD <sub>avr</sub> : 2,95x10 <sup>-5</sup> SIL3 Performance level PL e, Category 4, MTTF <sub>d</sub> : high For emergency stop buttons/safety stop buttons For emergency stop buttons/safety stop buttons TÜV Nord

### LED in emergency stop button

LED displays can be individually programmed in the PLC program as shown below.

LED in push-button	Indicator	Description
Red	ON	Output bit 1 ON
	OFF	Output bit 1 OFF or Output bit 1 & 2 ON
Green	ON	Output bit 2 ON
	OFF	Output bit 2 OFF or Output bit 1 & 2 ON

### AS-i LED and Fault LED in combination

LED pair at the M12 contact.

AS-i (Green)	Fault (Red)	
OFF	OFF	AS-i voltage missing
ON	OFF	Normal operation
ON	ON	No data exchange with master
Flash	ON	No data exchange due to address = 0

### Push button control panel



**Smile 41xxxx-x**  
with one AS-i node for four pushbuttons.



**Smile 41Exxxx-x**  
with one AS-i safety node for e-stop and one AS-i node for three pushbuttons.



**Smile 41EKxxx-x**  
with two safety nodes (e-stop and mode selector) and one AS-i node for two pushbuttons.

# Emergency stop Grab Wire Safety Switch

# Stop-Line

## Approvals:



## Application:

Emergency stop Grab Wire Safety Switch along machines or conveyors

## Features:

- Duplicate extraction in two directions
- Up to 75 m length
- Robust
- IP 67
- Integrated emergency stop button
- Warned before the safety circuit is broken

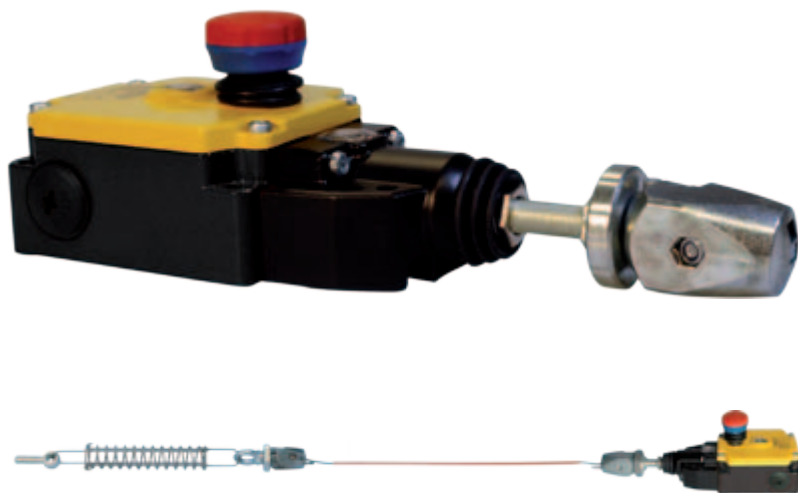

### Duplicated safety in both directions

Stop-Line is used for easy reach of an emergency stop along machines, conveyors and processes. Stop-Line is easier to install than a system of several emergency stop buttons along a carriage path. Stop-Line indicates operation status, reset or triggered mode. There is also indication of how taut the wire is.

Stop-Line can be used as protection for conveyors with low risks. The wire can, for example, be installed at waist height in front of the conveyor, which provides an emergency stop if someone falls towards the conveyor.

Stop-Line has four contacts. If someone pulls the wire or if the wire is broken, all the contacts are affected. In both cases, the machine is emergency-stopped. Just before the safety contacts are broken an indication is given since the wire may accidentally trigger the stop signal as a result of temperature differences.

To reset the Stop-Line the combined emergency- and reset button must be pulled out.

### Forced Disconnected Contacts

The contacts of the Stop-Line are forced-disconnected. Forced disconnection means that the contacts are mechanically pulled apart, thus ensuring protection against contact welding or sticking.

### Safety level

The forced disconnected contacts provide a high level of safety. To achieve a high level of safety in respect to the connection with the machine control system, it is appropriate to use a safety relay manufactured by ABB Jokab Safety. Stop-Line can be combined with Tina devices for use in a safety circuit containing other safety devices and emergency stops according to PL e.

### Regulations and Standards

The Stop-Line is designed and approved in accordance with relevant standards. See technical data.

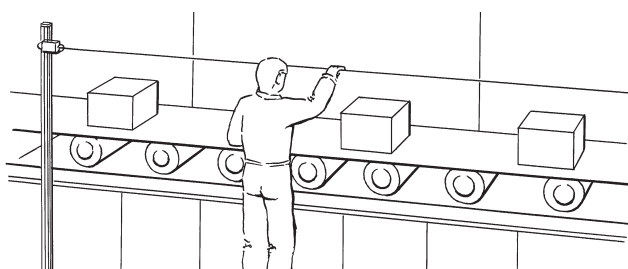

*Emergency-stop Grab Wire easily accessible during normal work operation along a machine*

Technical data – Stop-Line	
<b>Manufacturer:</b>	ABB AB/Jokab Safety, Sweden
<b>Article number/ Ordering data</b>	
Stop-Line 75A	2TLA020041R0000
Stop-Line 37A	2TLA020042R0000
Stop-Line 75B	2TLA020041R0100
Stop-Line 37B	2TLA020042R0100
<b>Colour</b>	Black with yellow label
<b>Level of safety</b>	Cat. 4/PL e, EN ISO 13849-1
<b>Housing Material</b>	Cast aluminium
<b>Lid Material</b>	Cast aluminium
<b>Operating temperature</b>	-30°C to +80°C
<b>Switching contacts</b>	2 NC + 2 NO
<b>Protection class</b>	IP 67, EN 60529
<b>Mechanical life</b>	100 000 switching cycles
<b>Max. switching frequency</b>	20/min
<b>Reset method</b>	mushroom-head slam button
<b>Max. wire length</b>	37,5 m./75 m.
<b>Mounting</b>	4 x M5/4 x M6
<b>Terminals</b>	Screw terminal, 8 x M4
<b>Cable access</b>	3 x M20 x 1.5
<b>Weight</b>	0,9 kg
<b>Max. voltage</b>	250 VAC
<b>Information output</b>	
Rated voltage	Ue 10-30 V DC
Rated current	Ie 50mA
<b>Thermal current</b>	10A
<b>Utilisation category</b>	AC 15, DC 13
<b>Short-circuit protection</b>	Melting Fuse 6A DII type gG
<b>Conformity</b>	EN ISO 13849-1, EN ISO 13850, EN60947-1, EN 60947-5-1, VDE 0113, EN ISO 12100-1, -2 och VDE 0660 T200.

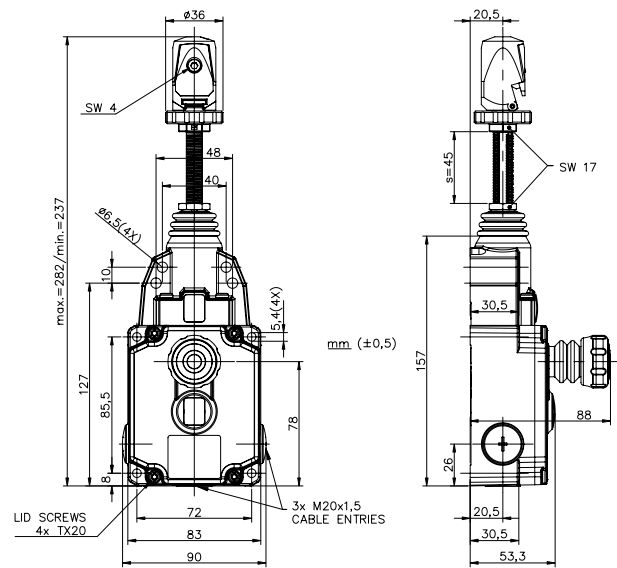

## Mounting – Stop-Line

The wire should be mounted at least 20 mm from the underlying surface. If the wire is longer than 25 m it must be supported with low friction supports. The ambient temperature during installation should be the same as during operation. For the Stop-Line type A.. After installation, pull the wire strongly several times and then adjust the tension to compensate for any extensions due to deformation of the thimbles.

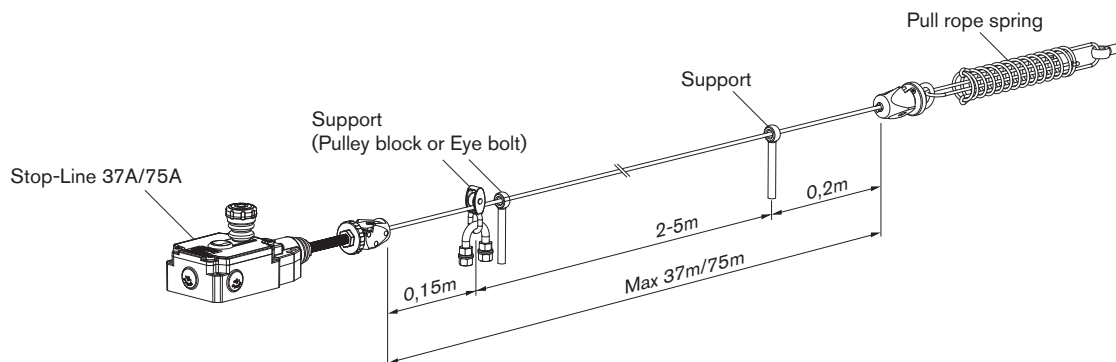

## Contact Adjustment Stop-Line

The tension is adjusted using the built-in set screw until the arrowhead is aligned with the label in the window (see picture below). When the combined emergency- and reset button is then pulled making the status window show green, all contact pairs are in operational mode and the machine can be started.

Pulling the wire, or if the wire is broken, all the contact pairs shift position and the machine is stopped. Before doing so, an electronic warning signal is provided which can be used to alert an operator to compensate for slow variations of the tension in the Stop-Line wire. This is useful to avoid unnecessary stops caused by e.g. ambient temperature variations.

Tolerance: distance  $\pm 0.5$  mm, power  $\pm 15\%$

- on (closed)
- off (open)
- ⊕ for contacts 11-12

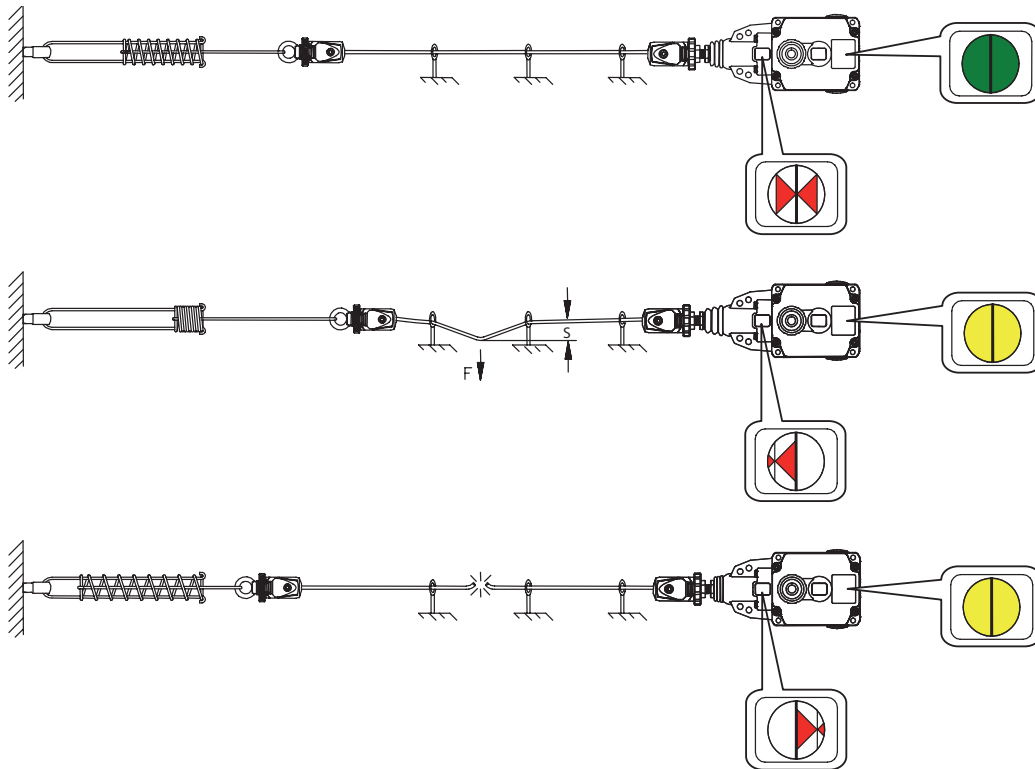
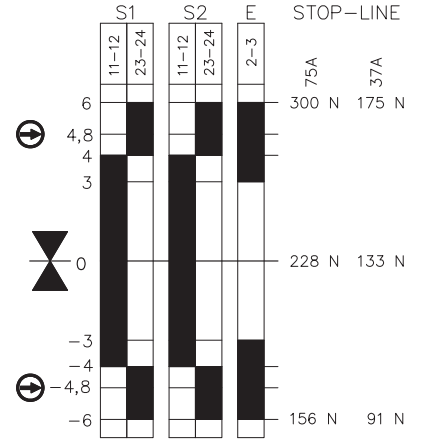

## Electrical Connection Stop-Line

Electrical connection of Stop-Line, highest level of safety.

24VDC/  
24VAC/  
48VAC/  
115VAC/  
230VAC/

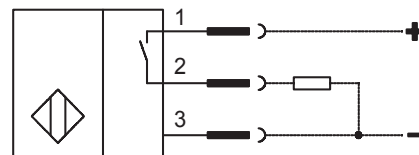
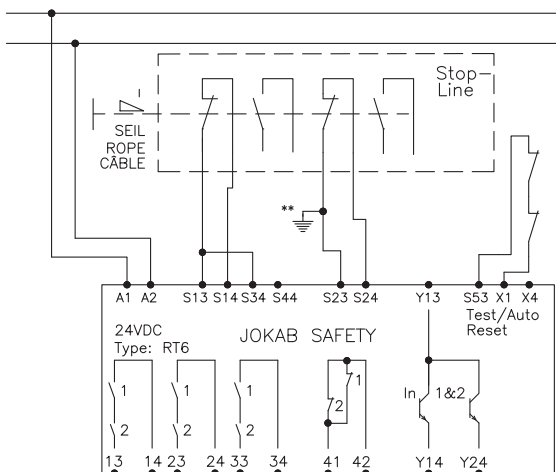











Connection terminal 1 and 3:  
Connection of supply voltage 10-30V DC

Connection terminal 2 and 3:  
Connection to signal circuit or lamp for indication

**Note!** The connection shows the Stop-Line in a correctly tensioned condition.



Ordering data – Stop-Line accessories		
<b>Installation kit 1</b>	<b>2TLA020043R1200</b> Contents: 2TLA020034R0500 x 25 Wire 2TLA020034R0400 x 6 Wire clamp 2TLA020034R0300 x 6 Thimble 2TLA020034R0600 x 1 Turnbuckle 2TLA020034R0900 x 8 Eye bolt M8x50	
<b>Installation kit 2</b>	<b>2TLA020043R1300</b> Contents: 2TLA020034R0500 x 40 Wire 2TLA020043R0100 x 1 Pull wire spring 2TLA020043R0300 x 9 Pulley block 2TLA020043R0600 x 9 Fastener for pulley block	
<b>Wire 3mm (sheath 4mm)</b>	2TLA020034R0500	
<b>Wire clamp for 3mm</b>	2TLA020034R0400	
<b>Thimble</b>	2TLA020034R0300	
<b>Turnbuckle</b>	2TLA020034R0600	
<b>Eye bolt M8x50</b>	2TLA020034R0900	
<b>Pull wire spring QF 75</b>	2TLA020043R0000	
<b>Pull wire spring QF 37</b>	2TLA020043R0100	
<b>Pulley block, unhinged</b>	2TLA020043R0300	
<b>Fastener for pulley block</b>	2TLA020043R0600	
<b>Pulley block, hinged</b>	2TLA020043R0400	
<b>Deflection pulley Ø 75mm</b>	2TLA020043R0200	

## Safety stop

# Inca and Smile

### When should I use the safety stop?

Safety stops are used to stop the operation of a machine in a safe manner. It must not be used as an emergency stop, but only as a stop for an individual hazardous motion. This is indicated by black push button. Likewise, an emergency stop push button with red push button must not be used as a safety stop.



#### Inca for panel mounting

The Inca series is available with black push button and is called Inca 1S/Inca 1S Tina. The safety stop is identical to the corresponding emergency stop apart from the black push button. For technical data see the Inca emergency stop.

Article number	Ordering data
2TLA030054R0300	INCA 1S
2TLA030054R0200	INCA 1S Tina

#### Smile with indication

The Smile series is available with black push button and has a similar designation apart from an S in the name instead of E. The safety stops are identical to the corresponding emergency stops apart from the black push button. For technical data see the Smile emergency stop.

Article number	Ordering data
2TLA030051R0900	Smile 11 SA
2TLA030051R1000	Smile 12 SA
2TLA030051R1100	Smile 11 SAR
2TLA030050R0500	Smile 11 SA Tina
2TLA030050R0600	Smile 12 SA Tina
2TLA030050R0700	Smile 11 SAR Tina
2TLA030050R0800	Smile 12 SAR Tina
2TLA030052R0100	Smile 11SA AS-i

## Reset button

# Smile 11R

### When do I need reset push button?

Smile 11RA/B are reset Push buttons intended to reset safety circuits. Smile 11RA has a connections for the NO-contact and for the LED in the PB. The reset LED is to be turned off after reset of the safety circuit. Smile 11RB is used together with our Pluto Safety Plc in order to reduce the number of terminals, one terminal is used as both input for the reset as well as output for the LED.



Technical data – Smile 11R	
<b>Manufacturer</b>	ABB AB/Jokab Safety, Sweden
<b>Article number/ ordering data</b>	
Smile 11RA	2TLA030053R0000
Smile 11RB	2TLA030053R0100
<b>Colour</b>	
Base	yellow
Pushbutton	blue
<b>Material</b>	
Housing	Polypropylene PP
Pushbutton contact	Au
<b>Power Supply</b>	
LED operating voltage	24 VDC (maximum 33 VDC)
LED current consumption	20 mA at 24 VDC 30 mA at 33 VDC
Pushbutton operating voltage	Min: 5 V, max: 35 V
Pushbutton current consumption	Min: 1 mA, max 100 mA
Pushbutton rated power	Max: 250 mW

<b>Ambient temperature</b>	-25...+55°C
<b>Humidity range</b>	35 to 85% (with no icing or condensation)
<b>Protection class</b>	IP65
<b>Connectors</b>	5-pole male M12 connector
<b>Size</b>	84x40x36 (LxWxH) + 12 mm for M12 connector (L)
<b>Weight</b>	aprox. 60 g
<b>Mechanical life</b>	1.000.000 operations at 10 mA/24 VDC
<b>Switching reliability</b>	10 x 10 <sup>-6</sup> at 5 mA/24 VDC

# Contact rails, Bumpers and Safety Mats

---

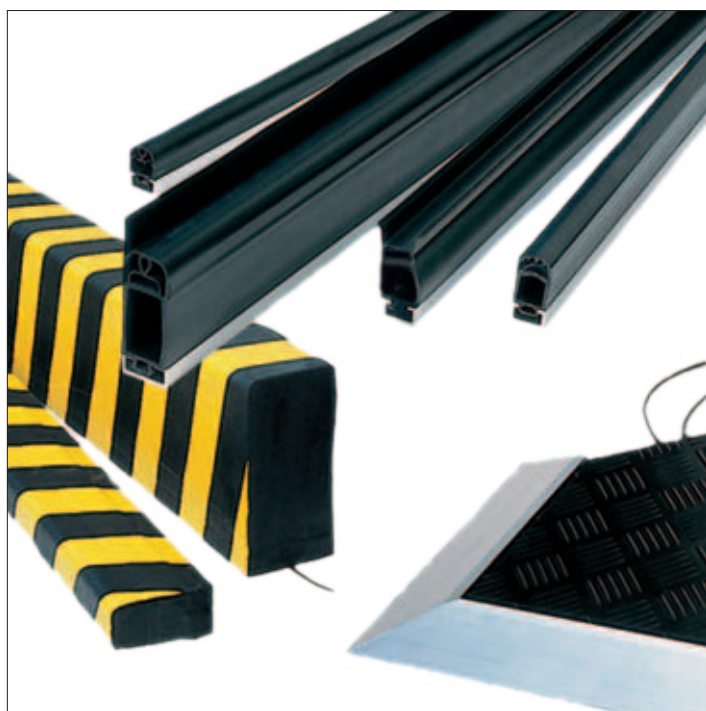

<b>Contents</b>	<b>Page</b>
<b><i>When shall I use contact rails, bumpers and safety mats?</i></b> _____	<b>12:1</b>
<b><i>Contacts rails and bumpers</i></b> _____	<b>12:2</b>
<b><i>Safety mats</i></b> _____	<b>12:8</b>

Descriptions and examples in this book show how the products work and can be used. This does not mean that they can meet the requirements for all types of machines and processes. The purchaser/user is responsible for ensuring that the product is installed and used in accordance with the applicable regulations and standards. We reserve the right to make changes in products and product sheets without previous notice. For the latest updates, refer to [www.abb.com/lowvoltage](http://www.abb.com/lowvoltage). 2011.

## When shall I use contact rails, bumpers and safety mats?

### ■ Contact rails and bumpers

Contact rails are used as protection against squeezing accidents, i.e. on moving machine parts and automatic doors and hatches. The strips come in customised lengths and various cross sections.

Bumpers are used as safety buffers to protect against remote control transport vehicles and other dangerous moving objects that require long stopping distances.

### ■ Safety mats

Safety mats are used for protection around hazardous machinery. They are well suited for monitoring an area used for loading and unloading of material to a machine.

#### §

**Standard: EN 1760-2 Safety of machinery - Pressure sensitive protective devices - Part 2: General principles for the design and testing of pressure sensitive edges and pressure sensitive bars**

#### §

**Standard: EN 1760-1 Safety of machinery - Pressure sensitive protective devices - Part 1: General principles for the design and testing of pressure sensitive mats and pressure sensitive floors**

# Safety contact rails & bumpers

## Approvals:



## Utilization:

Protection against squeezing accidents on moving machine parts and automatic doors.

## Features:

- Can be connected to a safety relay, Vital or Pluto
- Supplied in customized lengths
- IP 65
- Simple assembly on site
- Lengths up to 25 m.

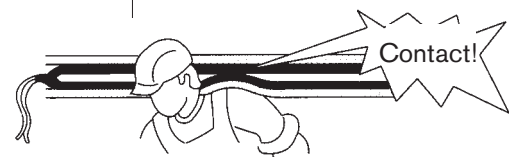
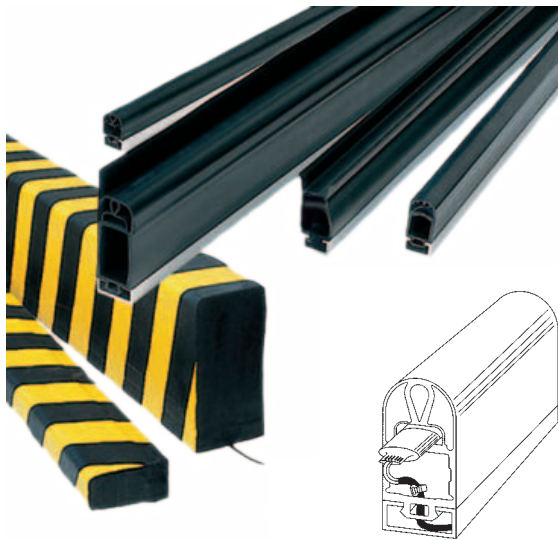

## Safety contact rails and bumpers as safety devices for potentially dangerous machines

### Safety contact rails

Contact edges are used as protection against crushing injuries, for example, moving machine parts, automatic doors.

### Contact edges with cast-in contact strips

Our new contact edges consist of a rubber profile with a cast-in contact strip. They are made up simply using connection plugs that are glued to the ends together with a terminal cap. The rubber profile is fitted on an aluminium profile.

Available in EPDM design. Supplied in lengths up to 25 m.

### Contact edges with contact strips SKS 18

The contact edge consists of a rubber profile with a safety contact strip inside. The contact edge is fitted on an aluminium profile.

The special design of rubber profiles of EPDM or NBR rubber

protect the inner contact strip in the best way possible against damage and also allow for a contact angle exceeding  $\pm 45^\circ$ . Normally supplied in lengths up to 25 m.

### Bumpers

Bumpers are employed on automatic production lines to minimise danger to both people and machines. The large foam rubber cushions enable long practical braking and run-through distances, thus enabling designers to optimise protection for both personnel and machines.

The safety contact strips are mounted inside aluminium profiles which are, in turn, protected by the large foam cushions that are glued to the carrier profile and then sprayed with a thin film of polyurethane which makes the bumper waterproof and helps to minimise wear and tear.

The bumpers are delivered mounted to the carrier profile in ordered lengths (0,2 m – 3 m).

## Fields of Application

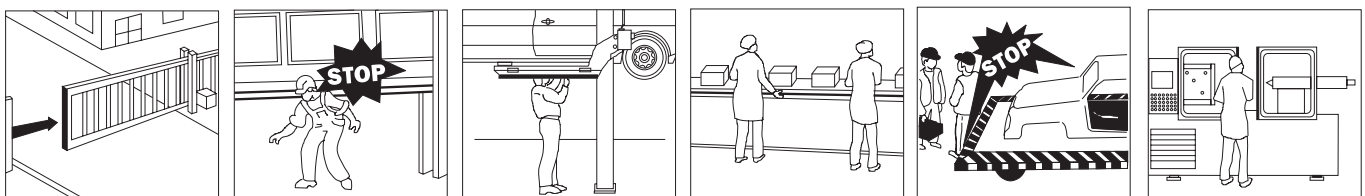



## Safety contact rails GP - General

The safety contact strip, SKS 18, the actual contactor, is located inside the safety contact rail. The safety contact strip consist of a homogeneous highly insulating outer EPDM material and has two internal conducting contact surfaces. The conducting elastomer contains two copper wires that provide low-resistance detection even in lengths exceeding 100 metres.

Because of the contact points, the safety contact rail has approximate 20 mm of inactive length at each end.

To provide protection against damage and to enable its proper use, the safety contact strip is inserted into the switching chamber of the rubber contactor profile. The rubber profiles (EPDM or NBR) are then permanently sealed with a special elastic adhesive and end caps to make them watertight.

The safety contact rail is then pressed into the aluminium profile.

### Safety contact rail, construction

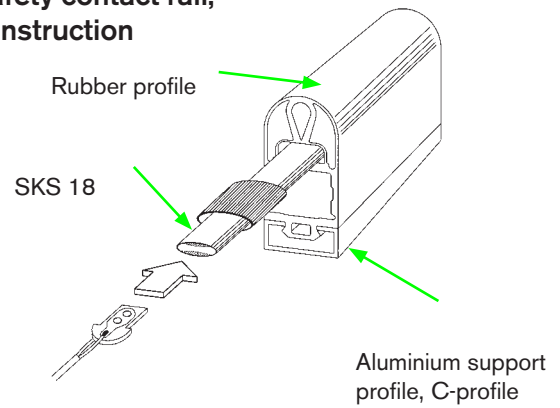

## Safety contact strip SKS 18 for contact edge GP

### Technical data - SKS 18

Outer material	EPDM, electrical insulation >30 Mohm
Inner material	EPDM, electrical elastomer with reinforce copper wire
Conductivity	60 ohm / 100 meters
Contact resistance	approx. 50 ohm
Max. electrical load	24 V / 100 mA
Max. applied pressure	6.5 N/cm <sup>2</sup>
Dimensions	18 x 6 mm

### Safety contact strip SKS 18

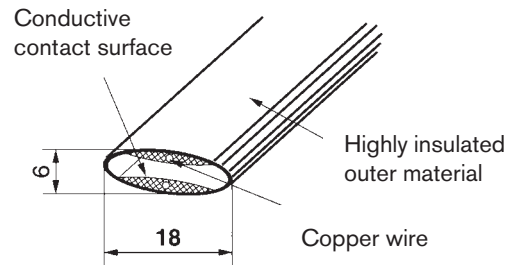

## Construction - contact edge GE

Inside the contact edge there is a cast-in contact strip that consists of two conductive alternating surfaces on the inside and a highly-effective insulating shell. There are two conductive wires in the contact surfaces that allow for low ohm measurements even when the contact edge has an extended length. The cast-in contact strip is protected against damage by the surrounding chamber. The cast end plugs ensure a permanent contact from the conductive surfaces in the contact strip. A special flexible adhesive is used to make the connector ring watertight.

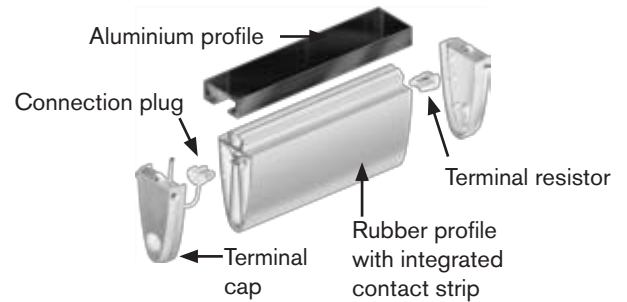

### Technical data - Rubber profiles

Type		GP 25-25	GP 25-40	GE 25-25	GE 25-45
Fixing Profile		AL 25-14	AL 25-14	Al 25-14	Al 25-14
Material		EPDM/NBR	EPDM/NBR	EPDM	EPDM
Length max (m)	(1)	6(10)	6(10)	25	25
Weight (g/m)		370	480	510	770
Weight incl. C-Profile (g/m)		690	800	820	1080
Activation force (N)	(2)	34/37	39/52	64,1	69,1
Actuating distance (mm)	(3)	8.0/7.5	9.4/9.7	4,7	6,73
Braking distance (mm)	(3)	10.2/9.5	7.2/5.9	6,48	20,73
Max. Actuating (°)	(4)	2x 45°	2x 60°	2x20°	2x20°

- (1) 10-metre lengths of GP edges on request
- (2) Measured with (Ø 80 mm test specimen), 10 mm/s
- (3) Measuring speed 10 mm/s
- (4) Not including DIN 31006-2 (GS - BE - 17)

**NOTE!** Contact us for other profile sizes.

## Common properties

Technical data - Contact rails		
<b>Manufacturer</b>	ABB AB/Jokab Safety, Sweden	
<b>Article number/ ordering data:</b>	<p><i>GP</i></p> <p>2TLA076025R2500 Contact rail GP25/25 EPDM. Ordered by length</p> <p>2TLA076125R2500 Contact rail GP25/25 NBR. Ordered by length</p> <p>2TLA076025R4000 Contact rail GP25/40 EPDM. Ordered by length</p> <p>2TLA076125R4000 Contact rail GP25/40 NBR. Ordered by length</p> <p>2TLA076009R0100 Ready-made, 2+2 m cable</p> <p>2TLA076009R0500 Ready-made, 5+5 m cable</p> <p>2TLA076009R0800 Ready-made, 7+7 m cable</p> <p>2TLA076009R1000 Ready-made, 10+10 m cable</p> <p>Please contact us for more alternatives.</p>	<p><i>GE</i></p> <p>2TLA076005R0200 Contact edge GE25-25 EPDM per metre.</p> <p>2TLA076005R0400 Contact edge GE25-45 EPDM per metre.</p> <p>2TLA076005R4400 Connection plug with 2.5 m cable.</p> <p>2TLA076005R4500 Connection plug with 5m cable</p> <p>2TLA076005R4600 Connection plug with 10m cable</p> <p>2TLA076005R4700 Connection plug with resistor 8.2kΩ</p> <p>2TLA076005R6100 Terminal cap for GE25-45</p> <p>2TLA076005R6200 Terminal cap for GE25-25</p>
<b>Mechanical load max <sup>1</sup></b>	500 N	
<b>Actuating angle (DIN)<sup>1</sup></b>	2x 20°	
<b>Mechanical life<sup>1</sup></b>	10 <sup>5</sup>	
<b>Max. operate temp. range<sup>2</sup></b>	-20°C to +55°C	
<b>Max. temperature range</b>	-25°C to +70°C	
<b>Protection classification</b>	IP 65	
<b>Max. Electrical load</b>	24V 100mA	
<b>Resistance</b>	0.6 Ohm/m	
<b>Conductors</b>	GP: 2x 0.38 mm <sup>2</sup> GE: 2x 0.34 mm <sup>2</sup>	
<b>Conductors insulation material</b>	GP: PVC GE: PUR matt blackt	

(1) According to DIN 31006-2 (GS - BE - 17)

(2) Not including DIN 31006-2 (GS - BE - 17)

## Physical and chemical material properties

Properties	EPDM	NBR	Resistance	EPDM	NBR		
Tensile strength	3	2	Water (distilled)	1-2	1	1 = no effect	for lasting contact
Tensile elongation	3	2	Acids (diluted)	1	3	2 = slight effect	non-lasting contact
Durability	3	2	Bases (diluted)	2	2	3 = moderate effect	moderate contact
Tear resistance	3	3	Non-oxidised acids	2	3	4 = appreciable effect	limited contact
Cold flexibility	2	3	Oxidised acids	4	5	5 = strong effect	short-term contact
Heat resistance	2	2	ASTM oil No. 3	6	1	6 = extreme effect	avoid contact
Oxidation resistance	1	3	Vegetable oil	5	1		
UV-resistance	1	3	Ester solvent	2	5		
Weather/ ozone resistance	1	3	Ketone solvent	3	5		
Flame resistance	6	6	Aliphatic hydrocarb.	5	1		
Gas permeability	4	2	Aromatic hydrocarb.	6	2-3		
			Halogenic hydrocarb.	6	5		
			Alcohols	1	5		
<b>1= excellent - 6 = poor</b>							

<b>EPDM</b>	Good resistance to ozone and weather, especially against chemicals
<b>NBR</b>	Good resistance to oil and petrol
<b>ASTM</b>	American Society for Testing Material
<b>Kw</b>	Aromatic hydrocarbon
<b>Ester</b>	Organic solvent
<b>Ketone</b>	Oxidized solvent
<b>Aliphatic</b>	i.e. petrol
<b>Aromatic</b>	i.e. benzol

**Note!** The information given is based on data obtained from the respective material suppliers. Although all efforts have been made, unforeseen factors can have a considerable effect on the generally applied indications during practical use therefore this information must be used as a general guide only. If there is any doubt as to the suitability of the materials used for any specific application/environment, we will, upon request, supply rubber samples for your own evaluation or, if given written specifications of your proposed environmental conditions, test the suitability of materials for your specific application.

## Mounting and electrical connection – Safety contact rails

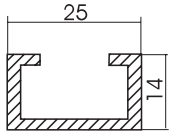

The selected contact profile should be mounted using a suitable aluminium C profile (as shown opposite).

### Mounting

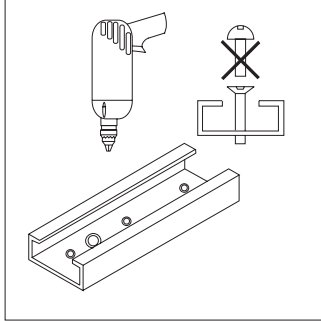

#### Stage 1 – GP and GE

Pan or round-head screws should not be used to mount the aluminium C profile. If such screws are used this can result in the connecting wire in the aluminium profile being damaged.

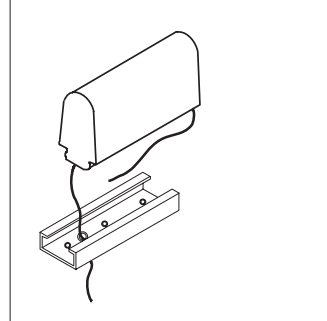

#### Stage 2 – GP and GE

In order to feed the connecting wire through the profile, an 8 mm hole must be drilled in a suitable position. Carefully remove the burr from the hole edges and insert the supplied rubber collar. The connecting wires can also be placed in the aluminium profile.

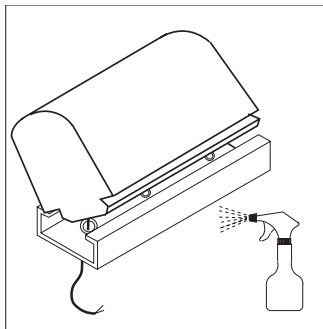

#### Stage 3 – GP

In order to make fitting of the safety contact rail easier, the aluminium profile and the safety contact rail should be sprayed with a water based soap solution. One side of the rubber profile must then first be inserted into the profile and then the whole profile pressed in. Once the soap solution has evaporated, the contact strip will be firmly fitted into the profile. In order to prevent subsequent slipping of the safety contact rail, talcum powder, oils or similarly permanent lubricating agents must not be used.

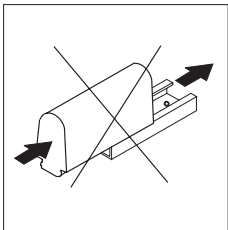

**Note!** Pulling or pushing the safety contact rail into the aluminium profile can cause damage to the contact rail and should be avoided at all costs.

Any other proposed methods of fixing should only be attempted after consultation with ABB Jokab Safety. Other methods of fixing, unless approved by ABB Jokab Safety may invalidate the warranty and may lead to incorrect device operation.

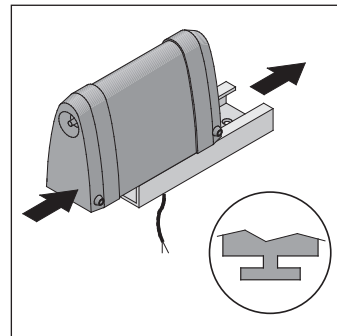

#### Stage 3 – GE

Safety contact edges with a t-base have to be pushed into the aluminium profile.

## The safety bumper principle

The contact function of the ABB Jokab Safety bumper consists of the safety contact strip SKS 18 being actuated by a special mechanical construction. This construction, which is protected by a large foam cushion, is inserted and glued to the carrier profile. The foam rubber is covered with a polyurethane skin. The safety bumper is also covered with cross-bound polyurethane, which can be provided in a range of colours. By utilising this construction the bumper gives a stop signal when impacted from all directions with soft sides.

The Safety Bumper must be connected to a suitable two input channel Safety Relay. e.g. ABB Jokab Safety type RT6 or RT7 which provides all necessary monitoring of the bumpers activation and detection of cable faults.

The twin cable connection makes it possible to connect several bumpers in series.

For further information and examples of electrical connection see Connection examples.

Technical data - Bumps	
<b>Article number/ ordering data:</b> 2TLA076200R0100 2TLA076200R0200 2TLA076200R0300 2TLA076200R0400 2TLA076200R0500 2TLA076200R0600 2TLA076200R0700 2TLA076200R0800 2TLA076200R0900 2TLA076200R1000 2TLA076200R1100 2TLA076200R1200 2TLA076200R1300 2TLA076200R1400 2TLA076200R1500 2TLA076200R1600 2TLA076200R0000	Bumper ASB 53/100 black 100/200 black 150/300 black 200/400 black 53/100 black/yellow 100/200 black/yellow 150/300 black/yellow 200/400 black/yellow 60/100 NBR black (63/100) 100/200 NBR black 150/300 NBR black 200/400 NBR black 200/200 black 150/150 NBR black 100/200 NBR black/yellow 150/250 NBR black/yellow Bumper base price
<b>Dimensions</b>	in accordance with the illustration, or special dimensions
<b>Actuating distance</b>	approx. 20% of height
<b>Braking distance</b>	at least 50% of height
<b>Actuating force [N]</b>	150 N at 80 mm around the test specimen
<b>Life</b>	greater than 10 <sup>5</sup>
<b>Protection class</b>	IP 65
<b>Ambient temperature</b>	-20° to +60°
<b>Chemical resistance</b> Oil, grease 10% acid 10% alkaline (caustic) solutions	good resistant resistant
<b>Connection cable</b>	2 x 2 m; 2 x 0,34 mm <sup>2</sup> PU covered

Foam rubber core

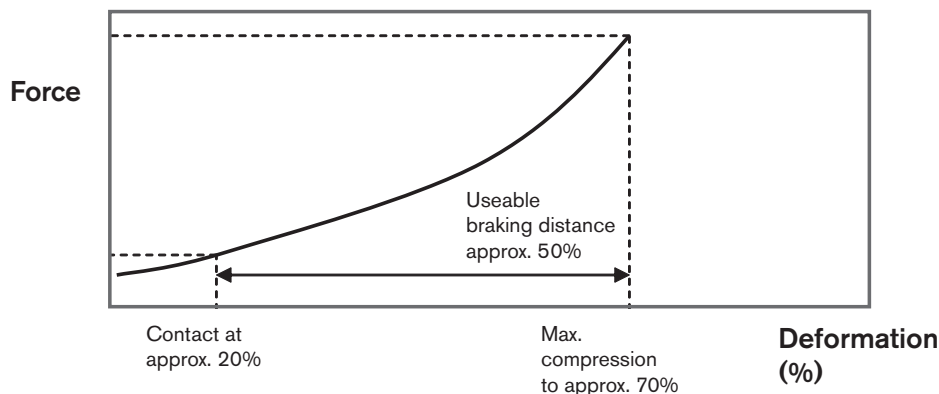
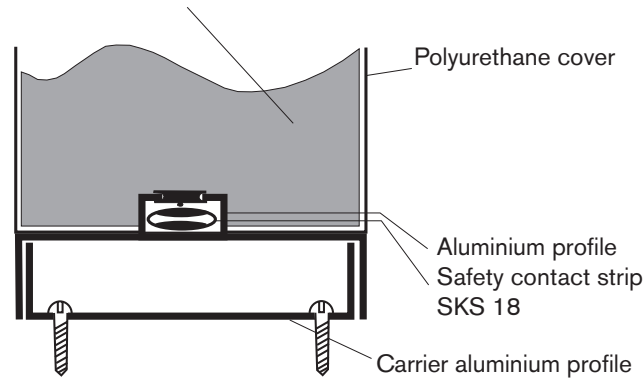

# Standard shapes

Shape A

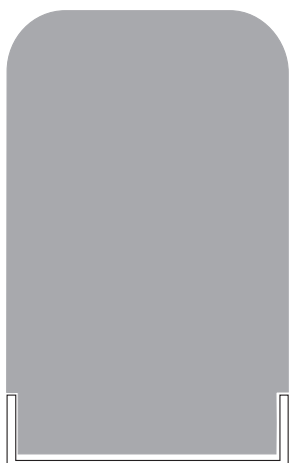

Shape B



Customer-specified special shape

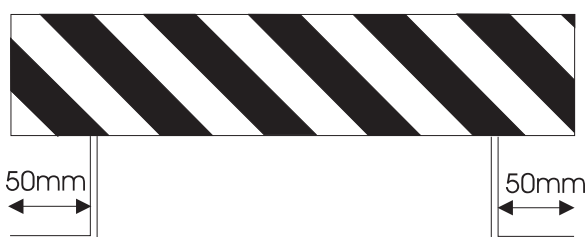

Cable exits at the ends of the bumper or according to customer requirements.

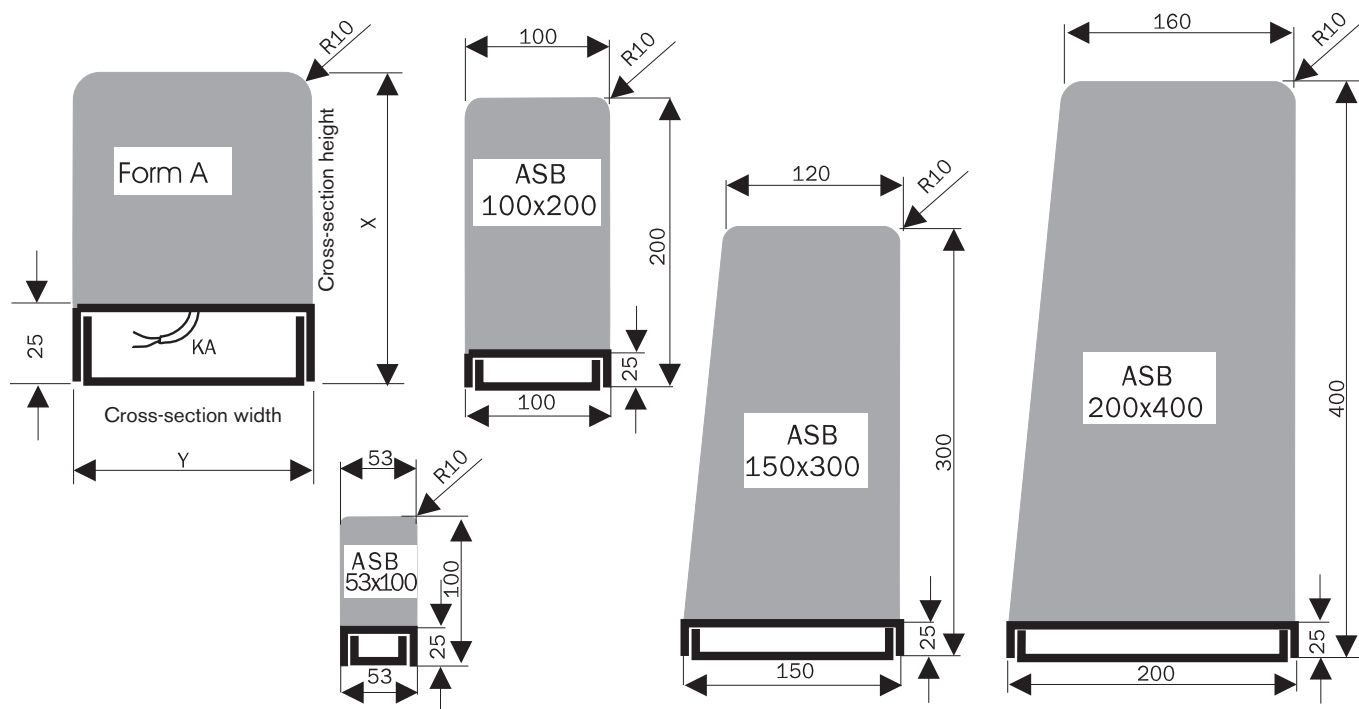

## Dimensions

Bumpers are available in four different standard dimensions. Other dimensions can be supplied on request. Note that in the case of customised orders, the ratio of 2:1 for X:Y must not be exceeded. Bumpers can be supplied in lengths of up to 3000 mm. The minimum cross-section is 53 x 100 mm.

# Safety Mats

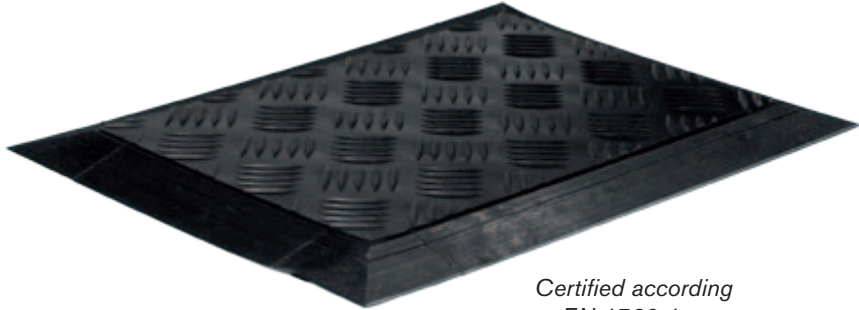

Certified according to EN 1760-1.

## Approvals:



## Safety Mats for:

Personal protection within the dangerous areas around presses, robots, production lines, machines etc.

## Features:

Can be connected to a safety relay, Vital or Pluto

Very durable

IP 67

## A Safety mat used as personal protection within dangerous areas.

The ASK Safety Mat is used as personal protection within the dangerous areas around presses, robots, production lines, machines etc.

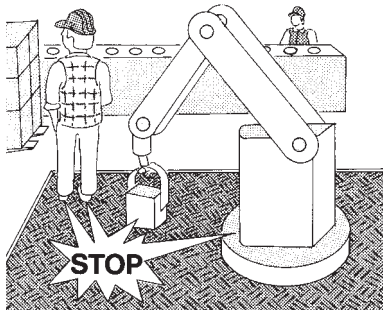

When connected to a suitable monitoring system stepping on the Safety Mat will immediately be detected causing dangerous machine movements to be stopped. This is made possible by the detection of electrical contacts closing within the sandwich construction of the Mat. As a load-bearing component the Mat is made with a bottom plate of either synthetic material or metal. The Safety Mat is provided with a ribbed surface, which is fixed by adhesive to the surface of the Safety Mat.

The safety mat and its connection cabling can be supervised by a suitable ABB Jokab Safety safety relay, which provides PL d.

## Mat construction

The basic Mat construction consists of a ground plate of either PVC, Aluminium or Stainless Steel which provides protection against uneven ground etc. The Mat is made up of a sandwich construction, the pressure contact switch consisting of two conducting sheets separated from each other by a webbed isolating layer. The internal switching surface is cast into a durable polyurethane to protect against moisture, and this is then covered with a top layer of ribbed or chequered rubber mat or a thin aluminium plate.

Attachment to the floor is by means of a ramped edge trim or a z-profile made of aluminium. The ramp profile has a channel for connection cables.

Custom Mats can be made, i.e. special shape, resistant against harsh industrial environments (mineral oil, acid, bleach etc.) or with a non-slip surface or M12-contacts.

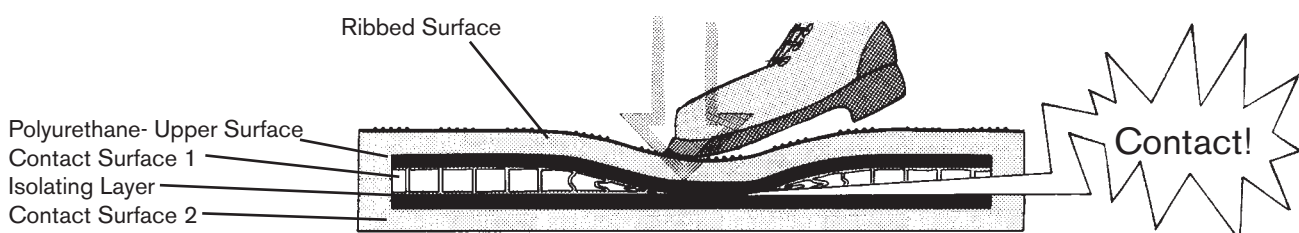



## Technical Data - Safety Mats

<b>Manufacturer</b>	ABB AB/Jokab Safety, Sweden
<b>Article number/ ordering data:</b> Production cost cast mat in PU with RF finish ASK-1U4.4-RF Production cost cast mat in PU with RF finish and cast-in ramp edge trim ASK-1T4.4-RF ASK-1U4.4-RF. No ramp edge trim: 1000 x 750 mm 1000 x 1000 mm 1000 x 1500 mm kvm ASK-1T4.4-RF. Cast-in ramp edge trim: 1000 x 750 mm 1000 x 1000 mm 1000 x 1500 mm kvm The above have a PU surface layer. Mats are available in any size and in other materials. Connection cabling including 1 off M8 male and 1 off M8 female: 2,5 m 5 m	2TLA076301R0000  2TLA076301R0200  2TLA076310R0500 2TLA076310R0600 2TLA076310R0700 2TLA076301R0500  2TLA076310R1000 2TLA076310R1100 2TLA076310R1200 2TLA076301R0600  2TLA076900R3200 2TLA076900R3300

<b>Max. area</b>	Entire mat = 2350 x 1350 mm 10 m <sup>2</sup> (divided mat) Rec. relation max 3:1 Min 100x100 mm
<b>Height</b>	10mm without ribbed surface max 14.5 mm with ribbed surface
<b>Inactive Area</b>	Nominally 10 mm from Mat edge
<b>Switching Force</b>	150N (Round body 80mm)
<b>Max. Pressure</b>	2000 N over ø 80 mm
<b>Material</b>	Black polyurethane, other colours on request
<b>Protection Class</b>	IP 67
<b>Ambient Air Temperature</b>	0°C to +60°C
<b>Chemical Resistance</b> Oil, grease 10% acid 10% alkaline (caustic) solutions	good resistant resistant
<b>Cable</b>	2 x 5 m, 2 x 0,34 mm <sup>2</sup> , PU sheathed
<b>Mechanical Life</b>	> 1,5x10 <sup>6</sup> load shifting

## Edge Trim - Safety Mats

### ASK-1U4.4-RF

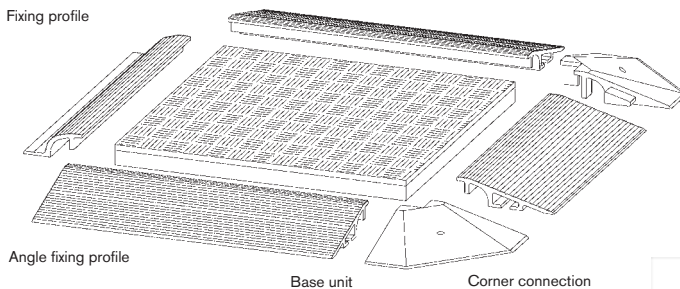
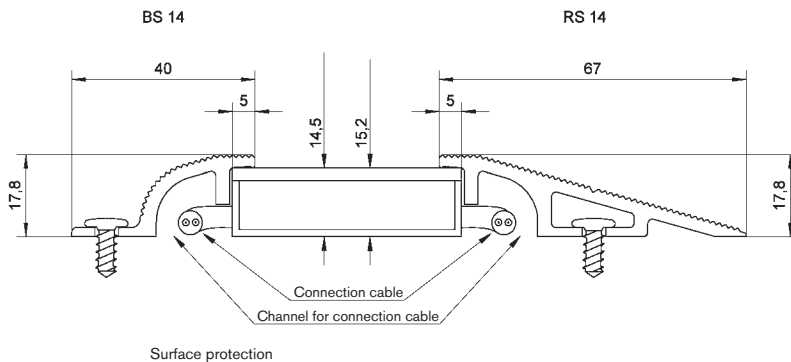

### Edge trim RS 14

Art nr: 2TLA076300R0500  
Eliminates vertical edges and attaches the  
Safety Mat to the floor. Also provides protec-  
tion and channel for connection cables.

### Profile BS14

Art nr: 2TLA076300R0800  
Best for use on the side nearest the machine.  
Permits a shorter distance from, for example, a  
wall.

### Corner trim

Art nr: 2TLA076300R0900  
Can be used between two RS 14 profiles as an  
alternative to mitre cutting of profiles.

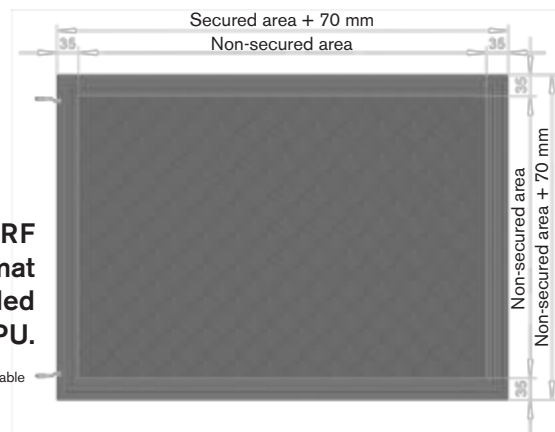
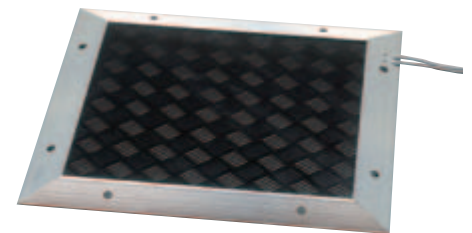

**ASK-1T4.4-RF**  
Completely moulded mat  
with moulded  
edge profiles in PU.

Connection cable

## Surface layer - Safety mats

Safety mats are normally supplied with a ribbed polyurethane non-slip surface layer that withstands tough conditions very well (oil, acid or caustic substances) and has anti-slip properties. If required, other patterns can be supplied, or for special requirements even other materials, such as NBR rubber or chequer plating in aluminium or stainless steel. Safety mats can also be supplied without a surface layer, to have a full coverage rubber sheet glued on during installation. Please contact us for more information about these alternatives.

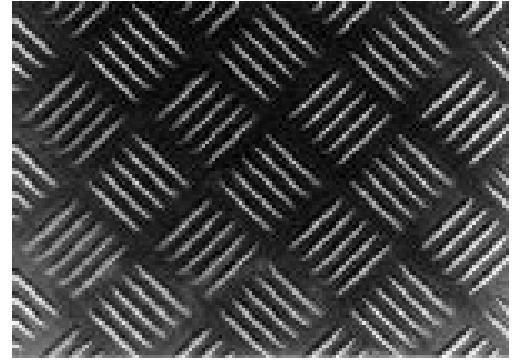

## Safety distance - safety mat as per EN ISO 13855

If a safety mat is used as entry protection, the smallest permitted safety distance between the hazardous area and the outer edge of the mat (seen from the hazard) is calculated using the formula from EN ISO 13855.

$$S = (K * T) + C$$

where

S = smallest permitted safety distance in mm

K = body speed (velocity of propagation 1600 mm/s)

C = additional distance in mm based on the intrusion of the body into the risk zone before the protection device is actuated (1200 mm)

*i.e.*

$$S = (1600 * T) + 1200$$

## Mounting - Safety Mats

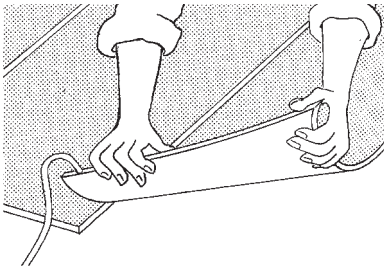

The ground on which the mats are to be laid must be level, clean and dry. The mats should not be glued to the ground.

Place mat in required position with groundplate downwards.

If more than one mat is to be installed be sure to place the mats edge to edge (without space).

If the mats are delivered without the ribbed surface premounted, the selected surface should be placed in position over the mats and fixed by means of a suitable adhesive.

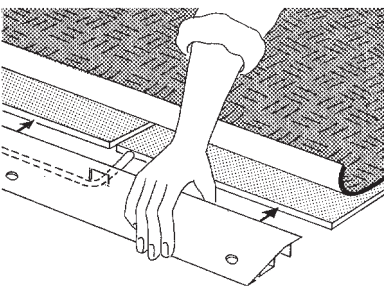

In the case of safety mats with cast-in rubber edge trim, the mat is secured to the floor by screws straight through the edge trim. In the case of safety mats with an aluminium edge trim, see below.

Place the selected edge trim to the mat. Edge trims are usually mitred (at 45 degrees) to provide complete protection around the corners of the mat.

Mark the cable routes on the edge trim and cut out slots to allow cable access into the cable channel as indicated. Connect the cables as shown under Electrical Connection.

Mark the locations of the securing screws along the scribed line on the edge trim. It is recommended that fixing screws should be located at 60 cm spacing.

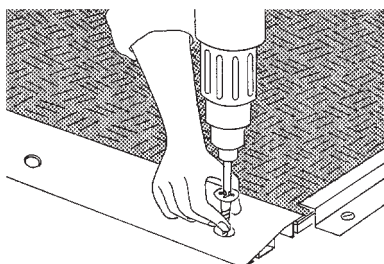

Secure the edge trim to the ground with 6 mm plugs and suitable screws. Plug the holes above the screws in the edge trim with the cover plugs provided.

### NOTE!

Safety mats must not be rolled/twisted or modified in any way. It is also essential that mats are not cut into any shape or shortened following delivery.

## Electrical connection - Safety contact rails, bumpers and safety mats

Contact edge, bumper or safety mat must be connected to a suitable monitoring unit (e.g. ABB Jokab Safety safety relays RT6, RT7A/B, RT9, RT10, Vital with Tina 6A or Pluto safety-PLC).

The monitoring unit monitors the functionality of the contact protection and detects any breaks or short-circuits in the lines. Several crush protection units can be connected in series while still retaining the same level of safety.

When pressure is applied, the active surface of the contact area in the contact protection is closed and the safety output on the monitoring unit trips. A stop signal will be sent to the machine's safety circuits preventing any dangerous movements.

**Note!** If alternative units are used rather than the recommended ABB Jokab Safety relays, it is essential that the user checks their suitability with ABB Jokab Safety before use. Failure to do so may result in incorrect operation and/or damage to the safety bumpers and invalidate warranty.

### HK7601A - Connection contact protection for safety relay RT6

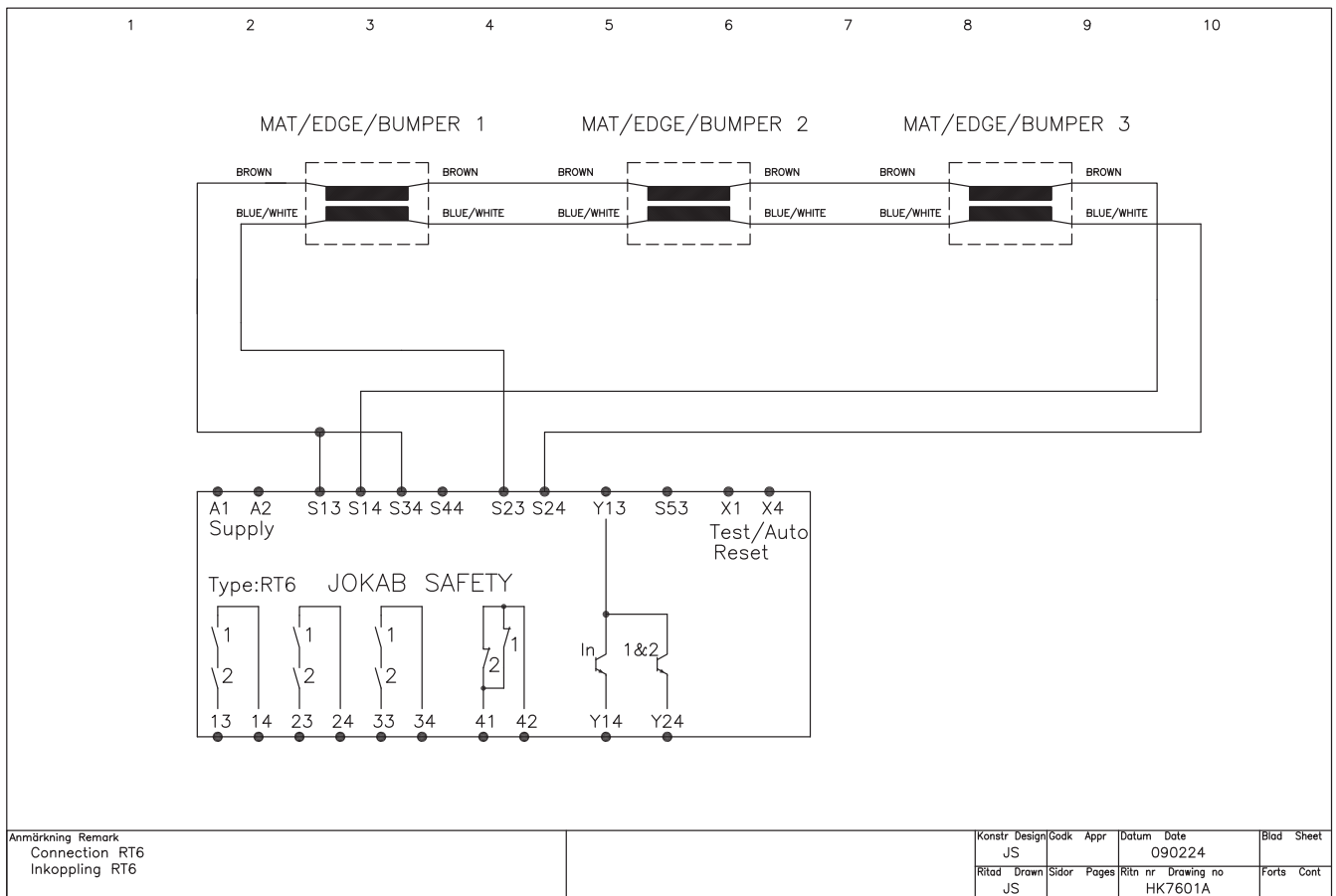

# HK3310A – Connection contact protection for safety controller Vital 1

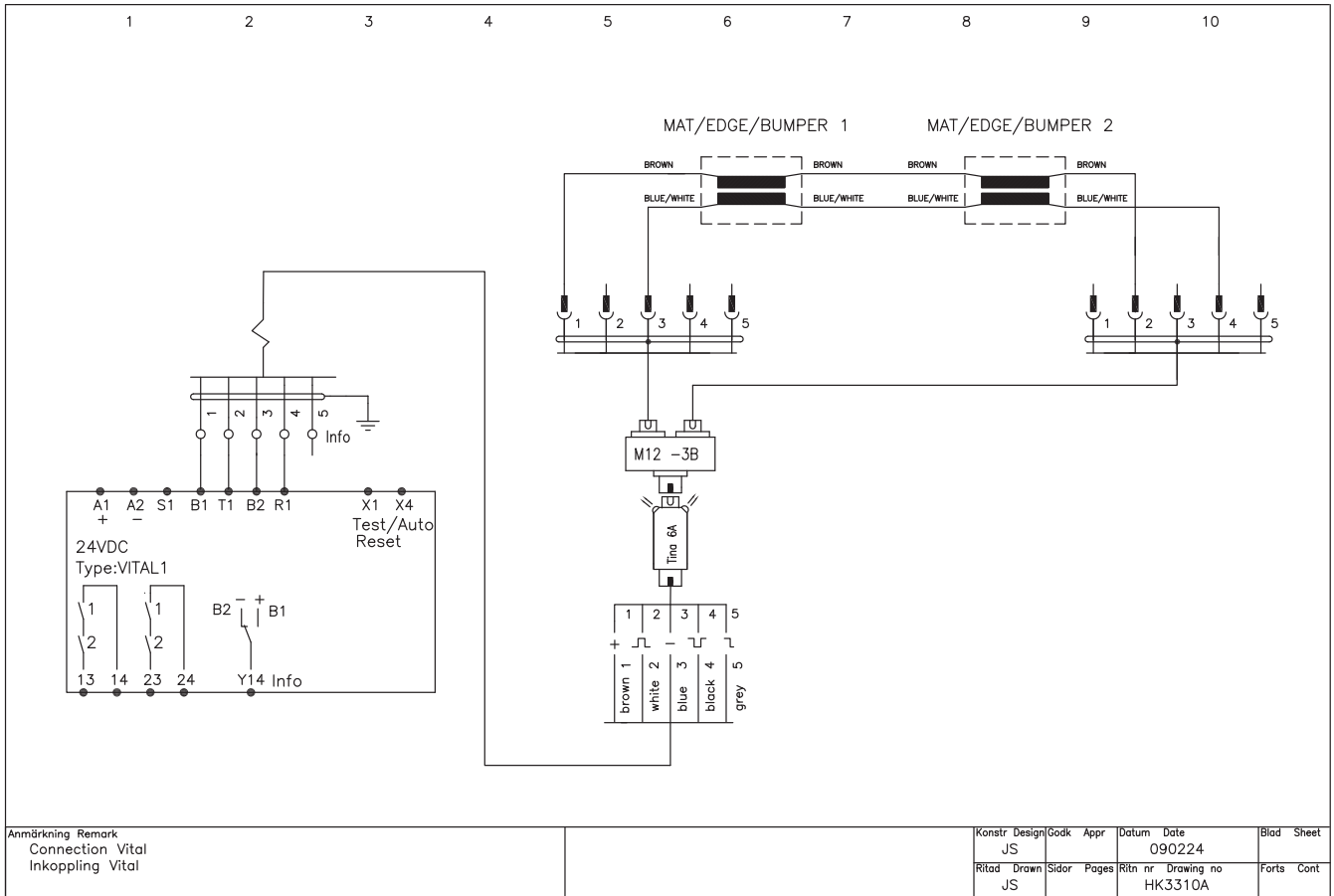

# HK0001A – Connection contact protection for safety PLC Pluto

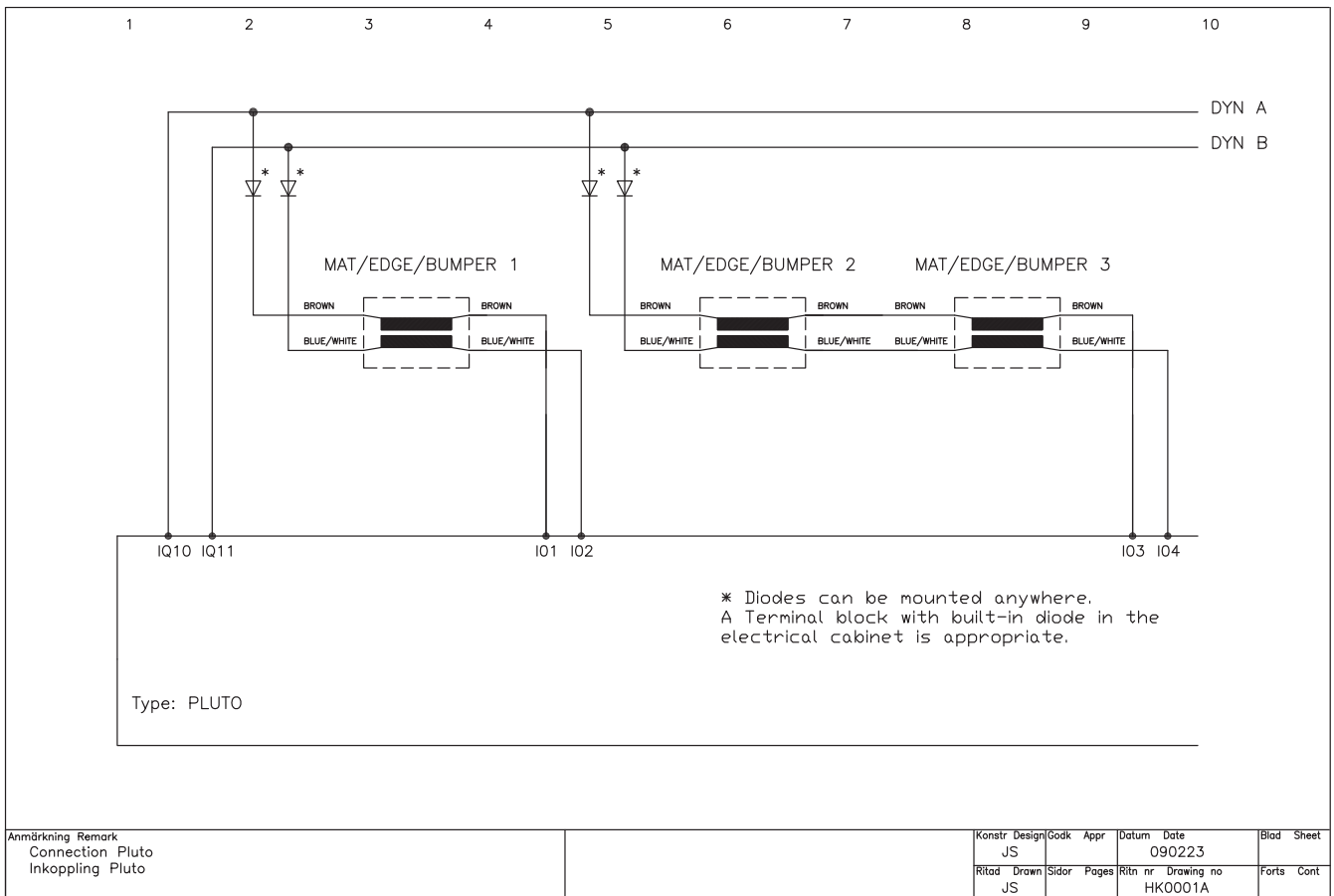



# Fencing system

Quick-Guard® and Safety Roller Door

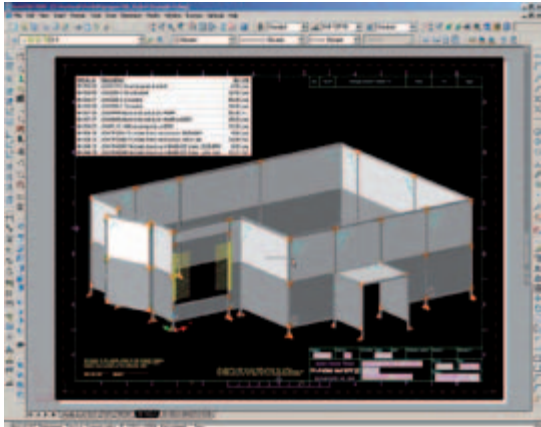



<b>Contents</b>	<b>Page</b>
<b>Quick-Guard® fencing system</b> _____	<b>13:2</b>
<b>Quick-Guard® is supplied in three possibilities</b> _____	<b>13:5</b>
<b>Quick-Guard® E</b> _____	<b>13:6</b>
<b>Quick-Guard® E - can be ordered in sections</b> _____	<b>13:7</b>
<b>Quick-Guard® standard and SafeCAD®</b> _____	<b>13:10</b>
<b>Assembly using NL2 and NL3 Net-locks on welded mesh</b> _____	<b>13:12</b>
<b>Dimensions for aluminium profile lengths and panels</b> _____	<b>13:13</b>
 <b>Components</b>	
▪ Aluminium profiles _____	<b>13:14</b>
▪ Fittings _____	<b>13:18</b>
▪ Door Components _____	<b>13:21</b>
▪ Fittings for Switches _____	<b>13:31</b>
▪ Terminal Caps and Strips _____	<b>13:34</b>
▪ Accessories _____	<b>13:35</b>
▪ Surfaces _____	<b>13:36</b>
 <b>Safety Roller Door</b> _____	 <b>13:38</b>

Descriptions and examples in this book show how the products work and can be used. This does not mean that they can meet the requirements for all types of machines and processes. The purchaser/user is responsible for ensuring that the product is installed and used in accordance with the applicable regulations and standards. We reserve the right to make changes in products and product sheets without previous notice. For the latest updates, refer to [www.abb.com/lowvoltage](http://www.abb.com/lowvoltage). 2011.

# Quick-Guard<sup>®</sup> - fencing system



Quick-Guard Standard assembled with mesh.

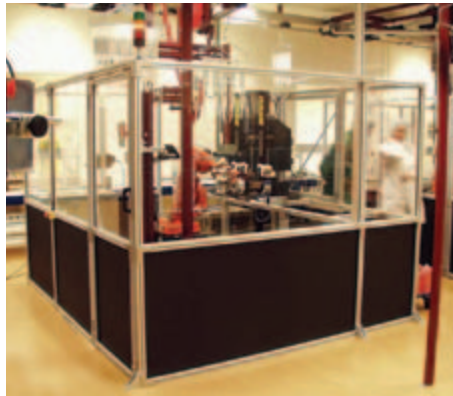

Quick-Guard Standard with black and transparent Polycarbonate in-fill panels as used for medical applications.



Quick-Guard E with few components and easy to angle at up to 45°.

## Adaption and Modification

Quick-Guard is a very flexible fencing system consisting of a minimum of different components, e.g. aluminium profiles, patented brackets, net-locks, mesh, solid or noise reduction panels. Using these components there are almost no limitations as to what can be built. Quick-Guard fencing costs little to assemble and modify.

## Assembly

Due to our patented screw-lock system, we can supply all brackets pre-mounted with fixing screws and nuts. No holes need to be drilled in the profiles and all cutting is straight. This makes assembly and modification very easy.

## Two versions of Quick-Guard

The Quick-Guard fencing system is available in two versions, Quick-Guard (Standard) and Quick-Guard E which also can be combined. The fencing systems are also easy to adjust when production equipment is modified and/or moved.

## Proposal and ordering

By utilising our AutoCAD-based SafeCAD program we are able to make system designs in 3-D very quickly. Drawings, cutting lists, etc. are generated from SafeCAD and the drawings can also be used for installation purposes.

## Our policy - To create systems that are environmentally friendly and provide ergonomic working conditions

Quick-Guard is environmentally friendly. All components in the Fencing System can easily be disassembled and reused. All materials in the Fencing System are 100% recyclable. Quick-Guard can also provide a pleasing ergonomic working environment.

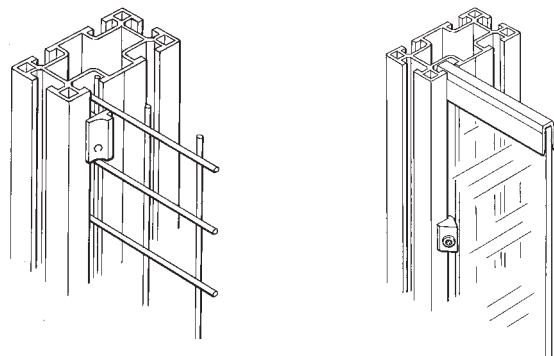

# A flexible and stable fencing system which is easy to install



Fixings with pre-mounted screws and nuts mean easy assembly

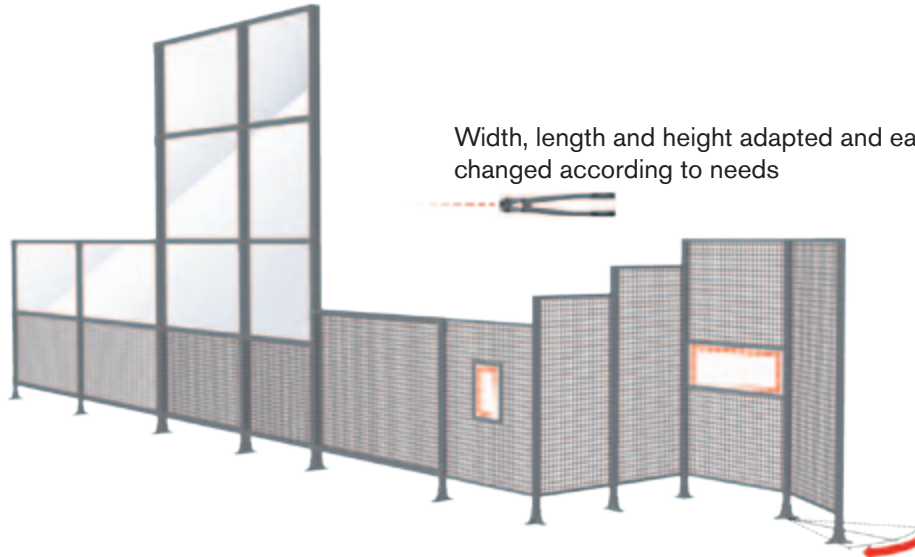

Width, length and height adapted and easily changed according to needs



Välj mellan ett stort antal automatiska och manuella luckor och dörrar

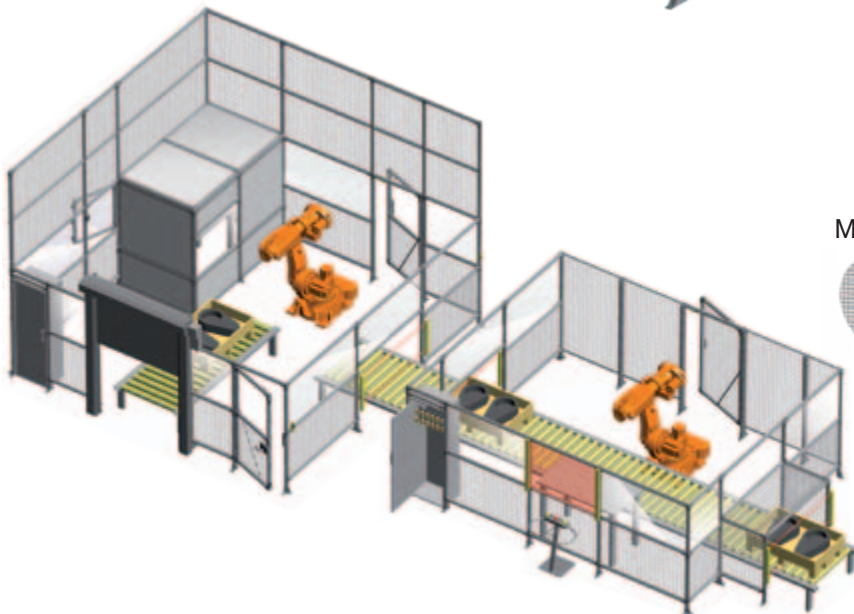

- Mesh
- Plastic
- Glass
- Plate
- Sound absorbing

# Patented assembly function

The ABB Jokab Safety patented guide and locking method makes it simple to assemble and dismantle the fencing system. The nut has several advantages, it can easily be located into the profile and automatically positions itself when the screw is turned 90 degrees clockwise. When in this position the bracket being fixed can be adjusted as required and locked by turning the screw further clockwise. To remove the bracket the fixing screw is turned anti-clockwise until the nut is in line with the profile slot.

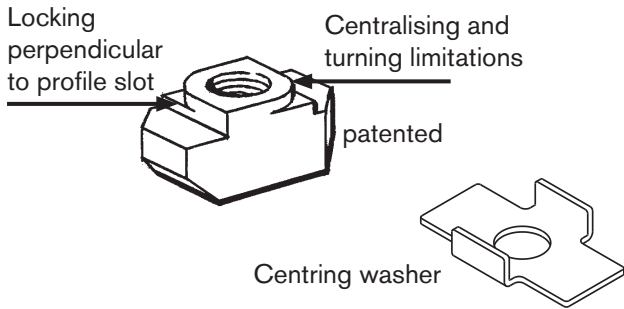
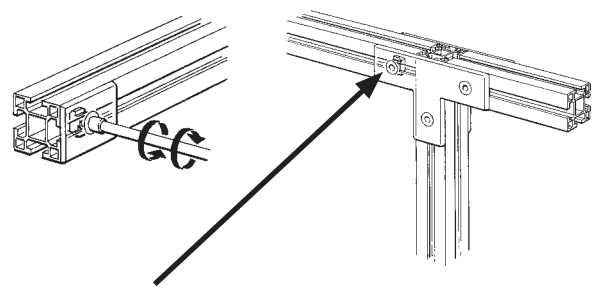

Mount the fixtures by first slackening the screw 3/4 turn anti-clockwise. Then tighten the screw clockwise in the usual way. The nut will then automatically mechanically lock the fixture into the profile.

All fittings are supplied Pre-assembled. Fittings that do not have a cast-in tab can be provided with a centring washer.

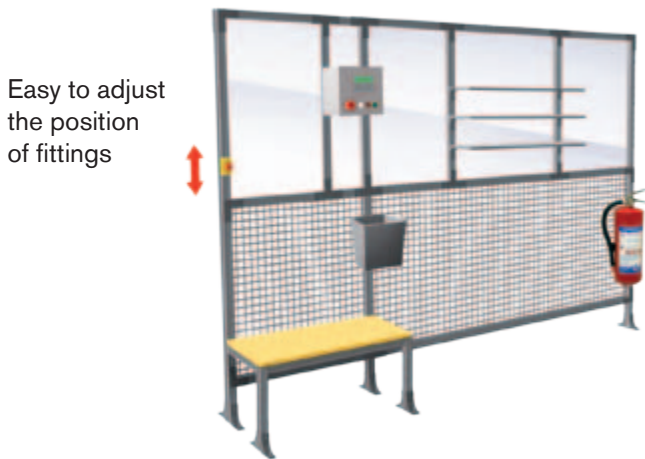

The T-slot and patented nut makes it easy to attach fittings to the fencing profiles

## What does the standard say?

EN ISO 13857 applies as safety distance for the risk zones. The standard includes the dimensions that apply for safety distances in various risk situations. The adjacent figure shows examples of dimensions for safety distances for two different fence heights where the risk of injury is relatively small when you reach in.

With respect to mesh, you specify a minimum distance of 200 mm (for people 14 and above) for mask size 40 x 40 mm. For shorter distances and for noise reduction we use fully fitting panels. When the fence is to protect a robot cell, for example, the fence protection should be placed at a minimum distance of 500 mm between the fence protection and the moving machine part that reaches furthest out (as per EN 349). When test running or programming there must be a space between the fencing and any moving parts to ensure the operator does not become wedged between them.

For protection that needs to be mounted and removed again, for example for maintenance, the Machinery Directive requires that fasteners remain in place on the protection. We normally deal with this using interlocked doors/gates for faster and safer access.

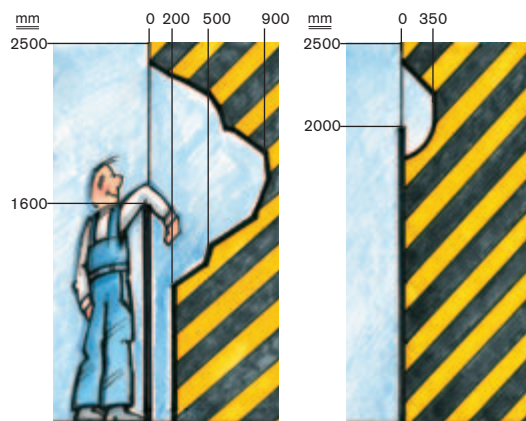

Safety distance for 1600 mm guarding with standard mesh. Safety distance for 2000 mm guarding with solid screens (e.g. polycarbonate sheet).

Safety distance for 1600 mm guarding with standard mesh. Safety distance for 2000 mm guarding with solid screens (e.g. polycarbonate sheet).



# Quick-Guard® is supplied in three ways

## 1. To be designed on site

You only order sections consisting of a few components. Then the fencing system is built on site. A manual mesh clipping tool, for easy cutting of the mesh, is provided with the delivery if needed. The profiles are easily cut with a crosscut saw. The advantage of using aluminium is that it is not flammable when cut. Compared to iron which require a fire-watcher in many industries.



## 2. Cut to size according to drawing

You give us a simple sketch or a AutoCAD® file of how you want the fencing system to look. We input this information into SafeCAD and design the fence in 3D. From this drawing, cutting and component lists and a quotation are generated automatically.

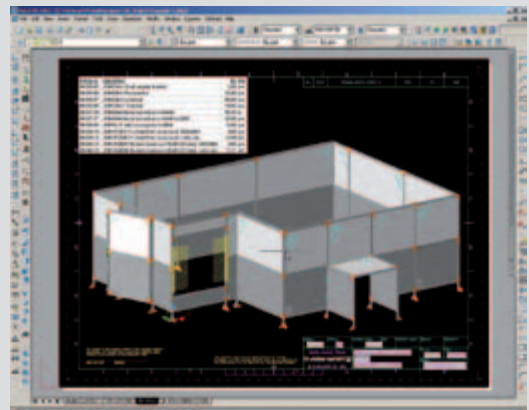

## 3. Pre-mounted or assembled on site

We can deliver full/partially pre-assembled fencing systems or we can assemble them on site.



# Quick-Guard® E - design directly on site

Quick-Guard E is installed quickly and cost effectively because it only consists of patented net-locks, welded mesh, panels of polycarbonate, u-profiles and fence posts (profiles with floor-brackets). All parts for Quick-Guard and pre-assembled doors are delivered immediately from stock. The few components of the fencing system make it easy for you to custom build and install the fencing system yourselves.

The strength of the fencing system originates from the fact that the welded mesh and/or panels of polycarbonate are 'locked' into the profile. The outer wire of the mesh is locked by uniquely designed 'netlocks' into the profile making the fixing virtually as strong as being welded. The polycarbonate panels are locked in with specially designed infill-locks which, according to our tests, have been as strong as the mesh netlock system. If you want more stable fencing posts, you can choose a sturdier profile measuring 44 x 88 mm instead of the standard 44 x 44 mm profile.

It is always easy to combine Quick-Guard E with Quick-Guard standard to achieve a complete system. It is also easy to adjust and modify the guarding system when production equipment is modified and/or moved.

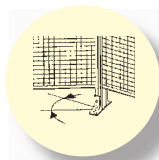
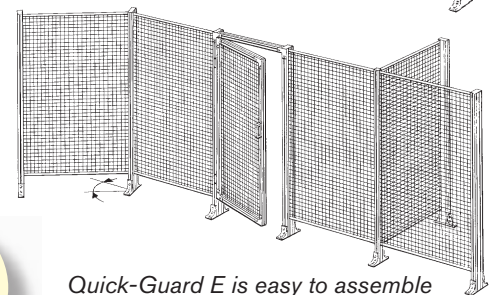
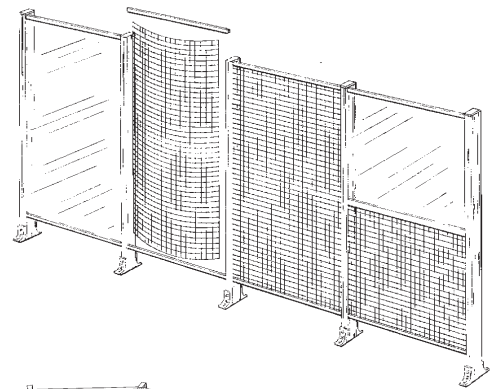

Quick-Guard E is easy to assemble and to angle 45°.

## Assembly of Quick-Guard E

1.

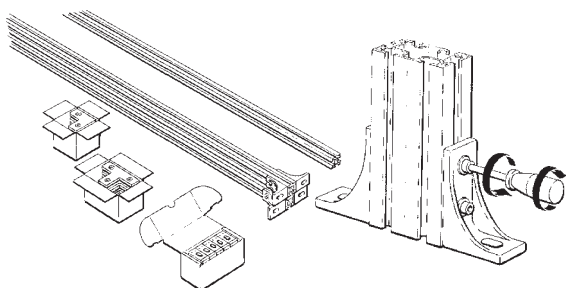

Premount floor fixtures on vertical posts. Mount fixtures by first slackening the screw anti-clockwise. Then tighten the screw clockwise in the usual way, the nut will then automatically locate into the correct position and mechanically lock the fixture into the profile. Make sure that the nut has turned correctly.

2.

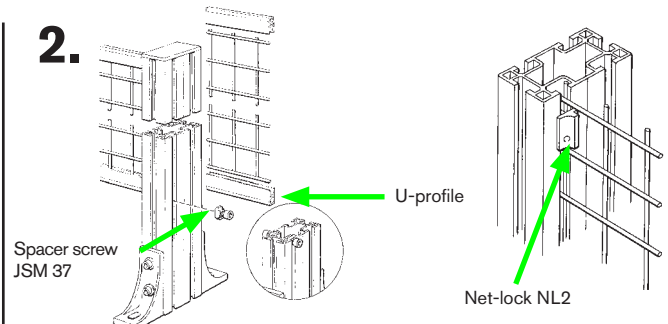

1. Insert spacer screw into the post profiles.
2. Place the lower u-profile on the mesh.
3. Push the mesh into the profile and fix the mesh with NL2 netlocks.
4. Fix top u-profile in place either before or after inserting the mesh.

3.

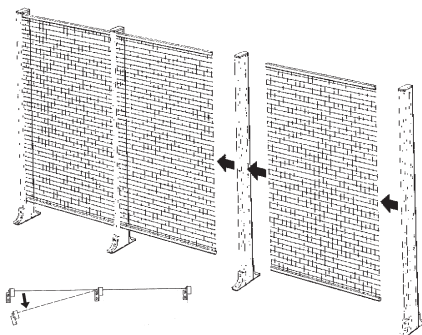

Assemble the next section. The distance between the posts can be adjusted some mm after the mesh is locked in with the Net-locks. The mesh can be angled up to 45° without using hinges (JSM 35-K).

4.

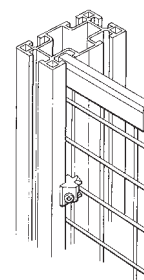

Lock the top of the mesh using NL3 netlocks; this way the mesh is secured, stabilised and electrically grounded. Grounding is needed when electrical devices or cables are assembled on the mesh.



# Quick-Guard® E

## - can be ordered in sections

Quick-Guard Express can be ordered in different sections consisting of a few components. By adding the different sections, one can easily build a guard fencing system.

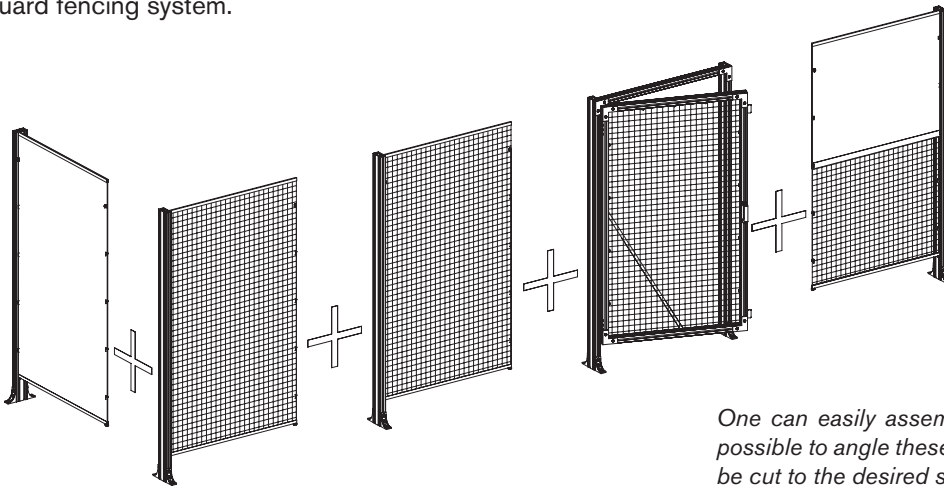

One can easily assemble the Express sections. It is also possible to angle these sections (45°). The mesh can easily be cut to the desired size with a simple clipping tool.



Measure the number of metres of fencing that are required and determine the number of doors. Our two standard sections have a cc width of 1100 mm and 1500 mm. The cc for the door is 1100 mm and fits anywhere the cc is 1100 mm between the posts.

If dimensions other than the standard dimensions are needed, just cut the mesh to the correct size with a bolt cutter.

### The same fencing sections can be erected in several ways.

- 4 pcs 1500 sections
- 5 pcs 1100 sections
- 1 pc door

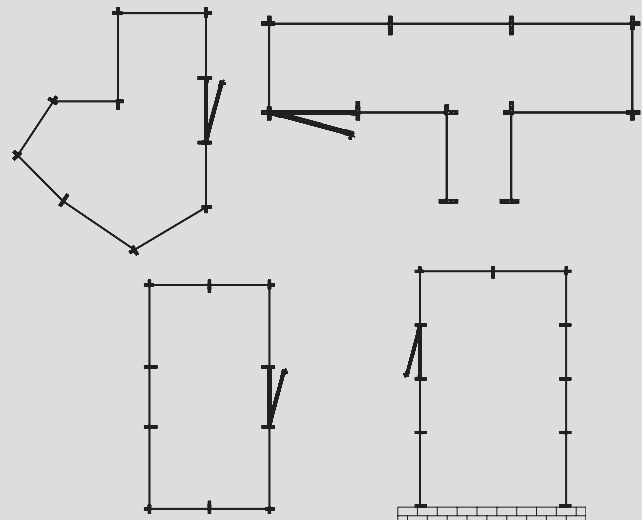
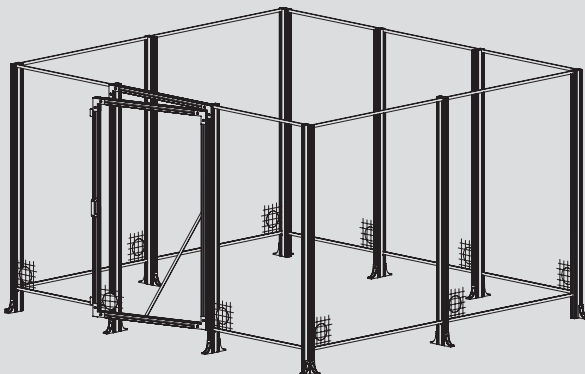

Designation explanation.

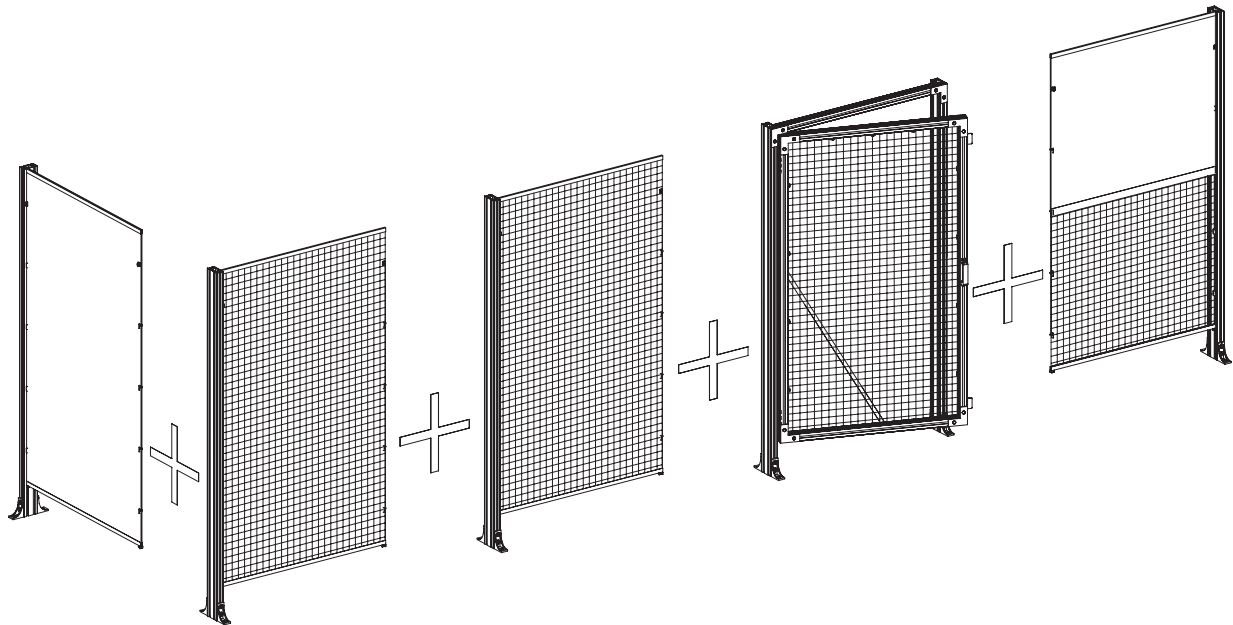
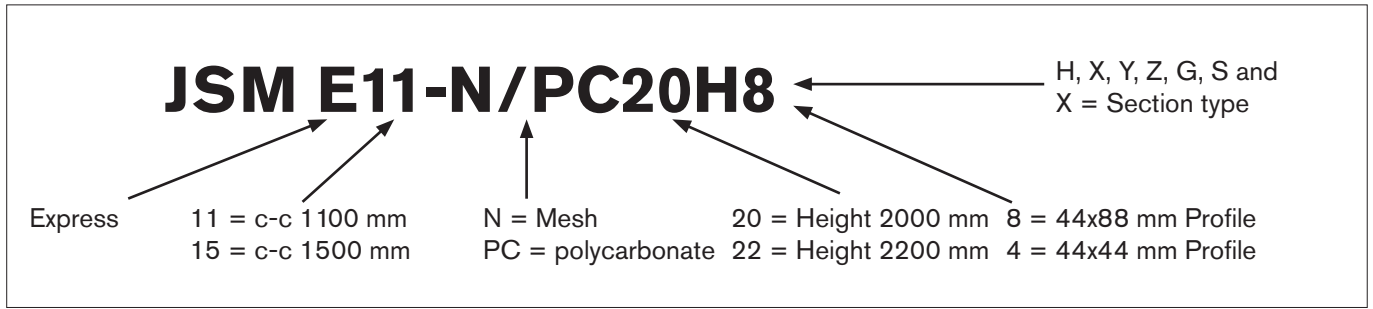

One can easily assemble the Express sections. It is also possible to angle these sections (45°). The mesh can easily be cut to the desired size with a simple clipping tool.

IMAGE	DESIGNATION	ART.NO.	DESCRIPTION
<b>Section X</b>			
	JSM E11-N14X4	2TLA040106R0200	Components for an additional section with only one post. The height can be varied between 2000 mm or 2200 mm. The section is supplied unassembled.
	JSM E11-N20X8	2TLA040101R0300	
	JSM E11-N22X8	2TLA040102R0300	
	JSM E11-N/PC20X8	2TLA040104R0100	
	JSM E11-N/PC22X8	2TLA040105R0100	Included parts: Floorbracket, netlocks/panel locks, support screws, edge protection, Aluminum profile and welded steel mesh/panel sheet.
	JSM E11-PC20X8	2TLA040101R5300	
	JSM E11-PC22X8	2TLA040102R5300	
	JSM E15-N14X4	2TLA040106R1000	
	JSM E15-N20X8	2TLA040101R0900	
	JSM E15-N22X8	2TLA040102R0800	

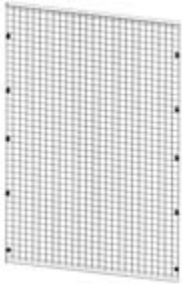
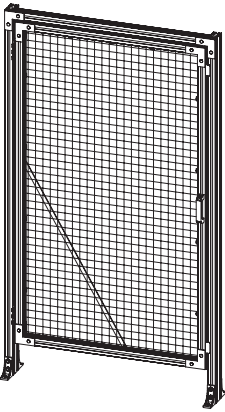
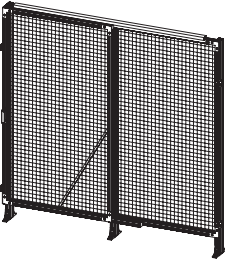
IMAGE	DESIGNATION	ART.NO.	DESCRIPTION
<b>Section Y</b>			
	JSM E11-14Y4 JSM E11-20Y8 JSM E11-22Y8	2TLA040106R8000 2TLA040103R2100 2TLA040103R4100	Components for a complete post with floor bracket to finalize the additional sections. The height can be varied between 2000 mm or 2200 mm. The section is supplied unassembled.  Included parts: Floorbracket, support screw, and Aluminum profile.
<b>Section Z</b>			
	JSM E11-N14Z JSM E11-N20Z JSM E11-N22Z JSM E11-N/PC20Z JSM E11-N/PC22Z JSM E11-PC14Z JSM E11-PC20Z JSM E11-PC22Z JSM E15-N14Z JSM E15-N20Z JSM E15-N22Z	2TLA040106R0400 2TLA040101R0400 2TLA040102R0400 2TLA040104R0200 2TLA040105R0200 2TLA040106R5400 2TLA040101R5400 2TLA040102R5400 2TLA040106R0800 2TLA040101R1000 2TLA040102R0900	Components for a complete section without fence posts and floor brackets. The height can be varied between 2000 mm or 2200 mm. The section is supplied unassembled.  Included parts: Netlocks/panel locks, edge protection and welded steel mesh/panel sheet.
<b>Section G</b>			
	JSM E11-N20G* JSM E11-N22G* JSM E11-N/PC20G JSM E11-N/PC22G JSM E11-PC14G JSM E11-PC20G JSM E11-PC22G  * The door leaf is supplied pre-mounted.	2TLA040101R0500 2TLA040102R0500 2TLA040104R0300 2TLA040105R0300 2TLA040106R5500 2TLA040101R5500 2TLA040102R5500	Components for complete conventional door with outer profile 44x88 mm. The height can be varied between 2000 mm or 2200 mm. The section is supplied unassembled. The size of the door can easily be adjusted on site.  Included parts: L-brackets, floorbrackets, netlocks/panel locks, handle, hinges, door stop, crossbar, aluminum profiles and welded steel mesh/panel sheet.
<b>Section S</b>			
	JSM E11-N20S JSM E11-N22S JSM E11-N/PC20S JSM E11-N/PC22S JSM E11-PC20S JSM E11-PC22S  JSM E15-N20S JSM E15-N22S	2TLA040101R0600 2TLA040102R0600 2TLA040104R0400 2TLA040105R0400 2TLA040101R5700 2TLA040102R5600  2TLA040101R1100 2TLA040102R1000	Components for a complete sliding door with outer profile 44x88 mm. The height can be varied between 2000 mm or 2200 mm. The section is supplied unassembled. The size of the door can easily be adjusted on location.  Included parts: L-brackets, T-brackets, floorbrackets, netlocks/panel locks, handle, suspension wheels, guiding components, door stop, crossbar, endcaps, aluminum profiles and welded steelmesh/panel sheet.

# Quick-Guard® standard and SafeCAD®

Quick-Guard consists of a minimum of different components, such as aluminum profiles, patented assembly parts, net-locks, mesh, solid or noise reduction panels. Furthermore the cost for assembly and modification of the system is low. Thanks to our patented screw-lock system, we can supply all brackets pre-mounted with fixing screws and nuts. No holes need to be drilled in the profiles and all cuts are made straight. Assembly and modification is therefore very easy.

To be able to quickly and easily custom design practical safety solutions, we have developed a computer programme, SafeCAD. This is a 'plug-in' program for AutoCAD®. A

simple sketch of the guarding system that is required is used as the program input. The positions of doors and hatches, choice of mesh, polycarbonate, aluminum/steel sheet or noise reduction panels are typed in. The program automatically generates 3D drawings along with component and cutting lists. These drawings are also used as the basis for assembly/ installation.

It is always easy to combine Quick-Guard E with Quick-Guard to achieve a complete system. It is also easy to adjust and modify when the production equipment is modified and/ or moved.

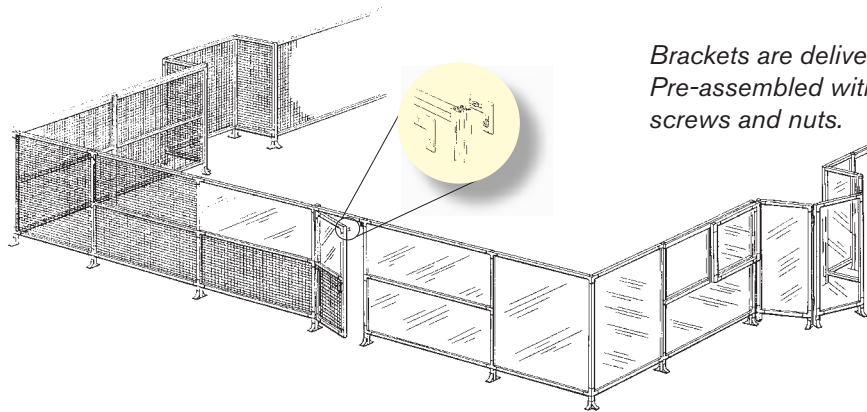

*Brackets are delivered Pre-assembled with screws and nuts.*

## Using SafeCAD® it is easy for both us and yourself to customize the safety solution for your needs

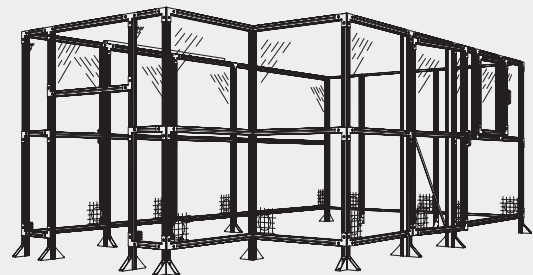
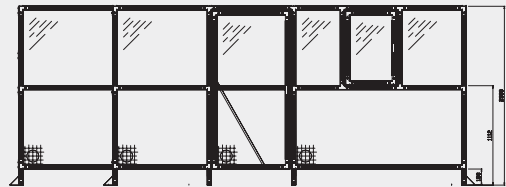
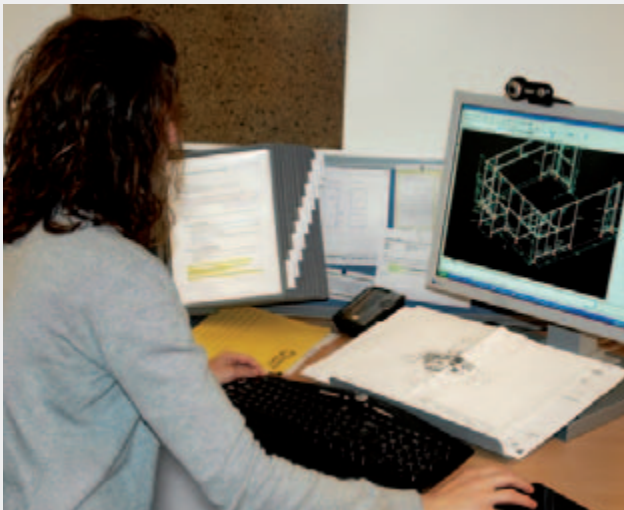

Example of component and cutting list print-outs from SafeCAD.

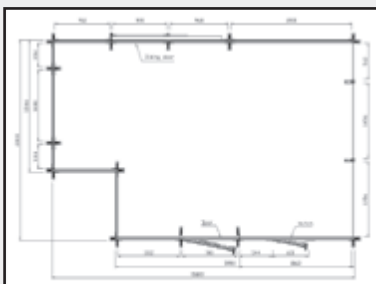

Article no	Description	Qty	Unit
40-030-06	JSM 30B-K Floorbracket	26,00	pcs
40-030-07	JSM 32B-K L-bracket	72,00	pcs
40-030-08	JSM 33B-K T-bracket	18,00	pcs

Cutlist Polycarbonate					
Article no	Description	Qty	Length	Width	Sum m <sup>2</sup>
40-039-10	JSM YPC5A1 Pc sheet 5mm uncoloured 2020x864	1	864	2020	1,75
40-039-12	JSM YPC5A9 Pc sheet 5mm uncoloured, cut to size	1	532	1020	0,54
40-039-12	JSM YPC5A9 Pc sheet 5mm uncoloured, cut to size	1	756	504	0,38

Cutlist Welded Mesh					
Article no	Description	Qty	Length	Width	Sum m <sup>2</sup>
40-040-13	JSM YN40W1 Welded steelmesh 40x40x3,5 black, 2020x864	1	864	2020	1,75
40-040-14	JSM YN40W2 Welded steelmesh 40x40x3,5 black, 1074x1816	2	1820	1074	3,91
40-040-16	JSM YN40W9 Welded steelmesh 40x40x3,5 black, cut to size	2	864	354	0,61
40-040-16	JSM YN40W9 Welded steelmesh 40x40x3,5 black, cut to size	1	864	804	0,69
40-040-16	JSM YN40W9 Welded steelmesh 40x40x3,5 black, cut to size	1	864	920	0,79
40-040-16	JSM YN40W9 Welded steelmesh 40x40x3,5 black, cut to size	2	864	932	1,61



## Quick-Guard® Assembly, standard version



Assembly of the Quick-Guard® system is very easy. All components are very light in weight and ergonomic in design. This enables, in most cases, one man to be able to assemble both simple and complex structures with ease using very few different types of fixing components. All fixtures can be mounted easily from "outside" by using the specially

designed "locking nut" which can be located anywhere in the extrusion channel. The fixture components, by means of integral locating keys, ensure that correct angles are achieved and enable the number of bolts/nuts to be reduced to half the number that would otherwise be required.

**1.**

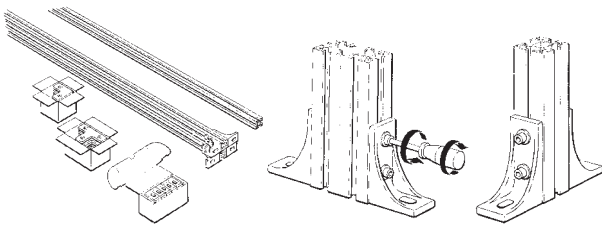

Premount floor fixtures by first slackening the screw anti-clockwise. Then tighten the screw clockwise in the usual way. The nut will then automatically locate into the correct position and mechanically lock the fixture into the profile.

**2.**

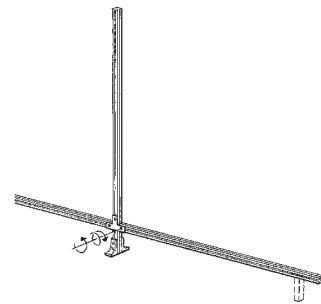

Attach lower horizontal extrusion between vertical posts. Use a spacing block to ensure the correct distance from the floor.

**3.**

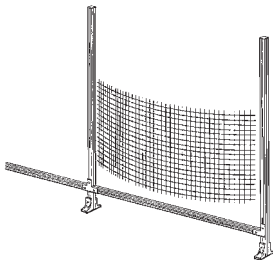

Insert infill panel and fix middle horizontal profile. The distance between the profiles is the width of the infill minus 20 mm.

**4.**

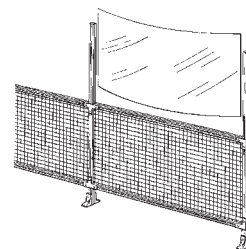

Insert top infill panel. Fix top profile with fittings on the top on both sides.

**5.**

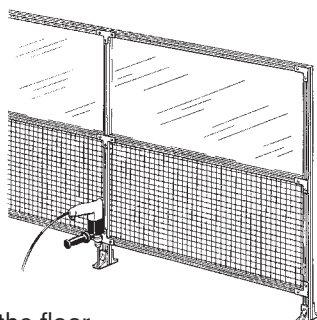

Fix the poles to the floor.

**6.**

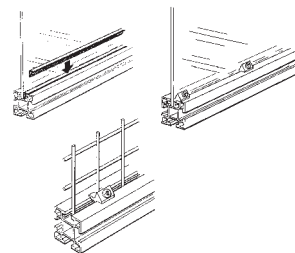

Secure infill sheet with plastic strip or Net-lock fixings. Easy, fast and quick. See more under Assembly of netlocks. If there is a risk of the robot striking the polycarbonate, JSM PL3 panel locks must be used.

# Assembly using NL2 and NL3 Net-locks on welded mesh

## NL2 Net-lock

The outer mesh wire is locked into the profile.

max 2 mm

When assembling the Net-lock NL2 it is first put into the profile as the drawing shows. Then the Net-lock is turned 90°. When cutting the welded mesh the wire ends should not be longer than two (2) mm.

## NL3 Net-lock

Mesh with outer wire.

Mesh without outer wire.

max 2 mm

min 15 mm

The outer mesh wire is locked into the profile.

The Net-lock locks the mesh against the profile.

When assembling the Net-lock NL3 it is first put into the profile with the tabs on each side of the mesh wire. The screw is then tightened. When cutting the welded mesh the wire ends should be at least 15 mm to fit into the profile. NL3 must be used to lock the mesh into the slot.

## Number of Net-locks

### Number of Net-locks Quick-Guard standard version

On Quick-Guard standard version NL3 is recommended as it can handle mesh with and without an outer wire.

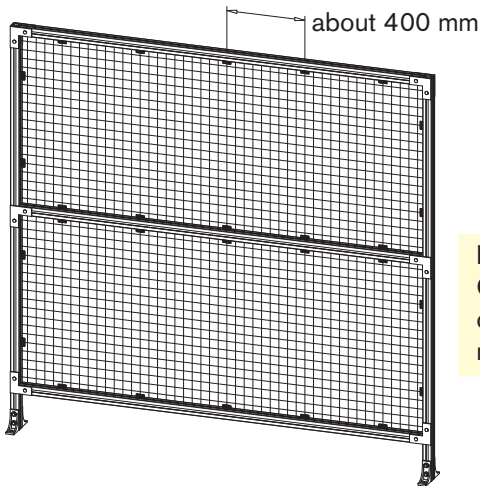

**Note!**  
On welded mesh without an outer wire NL3 must be used.

### Number of Net-locks Quick-Guard E

On Quick-Guard E both Net-lock NL2 and NL3 can be used. For mesh edges without outer wire NL3 must be used instead of NL2.

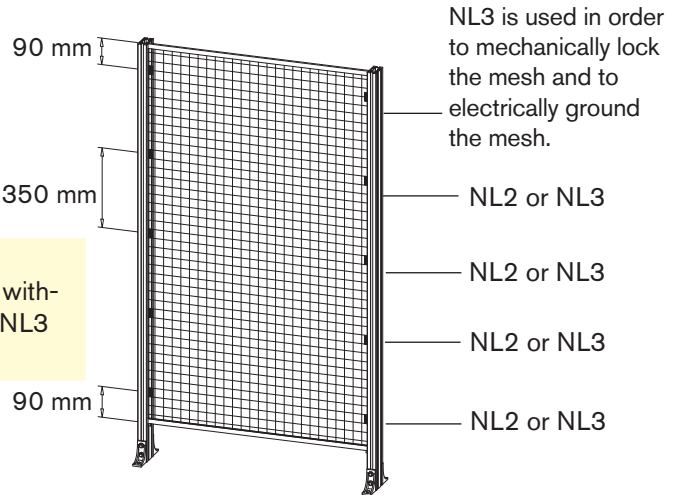

**NOTE!** On both Quick-Guard Standard and Quick-Guard E at least two NL3 should be used in order to mechanically lock the mesh and to electrically ground the mesh. NL3 should only be used on doors.

## Fixing posts to the floor when mesh is required to be fitted at a later date.

**Right**

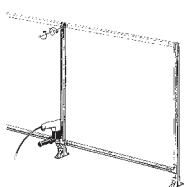

**Wrong**

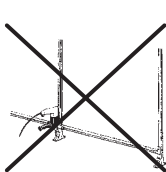

Temporarily mount at least two middle profiles before drilling and fixing posts to the floor. This method is used when infill mesh or panels are to be fitted at a later date.

**Note!** Never attempt to fix the posts to the floor without first connecting at least two middle profiles to ensure the posts are parallel to each other and vertical.



## Dimensions for aluminum profile lengths and panels.

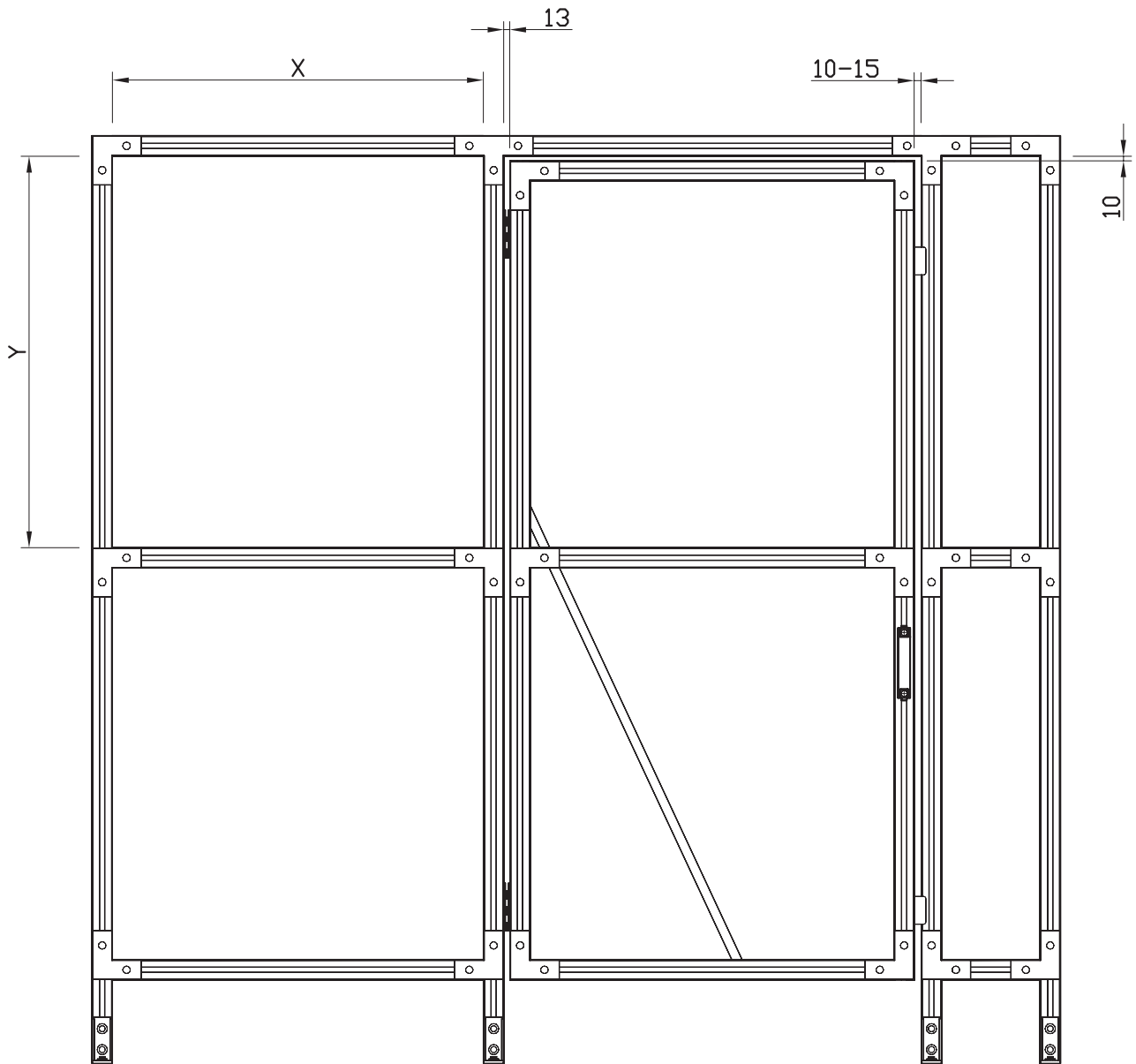

### Material

Polycarbonate  
 Welded mesh  
 Steel panel  
 Sound-absorbing panel 25mm  
 Sound-absorbing 50 mm  
 Laminated glass  
 Double Pc  
 Sound absorbent panel profile JSM AS1  
 Sound-absorbing profile JSM AS3  
 Double Pc profile JSM AS2

### Width

X+20 mm  
 X+20 mm  
 X+20 mm  
 X-37 mm  
 X-37 mm  
 X+15 mm  
 2 pcs. X-7  
 2 pcs. L=X  
 2 pcs. L=X (mitred 2 x 45 degrees)  
 2 pcs. L=X

### Height

Y+20 mm  
 Y+20 mm  
 Y+20 mm  
 Y-37 mm  
 Y-37 mm  
 Y+15mm  
 2 pcs. Y-7  
 2 pcs. L=Y-73  
 2 pcs. L=Y (mitred 2 x 45 degrees)  
 2 pcs. L=Y-33

## ALUMINUM PROFILES

A wide range of aluminium profiles are available and include, fencing profile, guide rails, and cable ducting. The cable ducting is available in three sizes, and can be delivered with or without mounting holes. The cable ducting is easy to open and can be provided with end caps. Cover strips of plastic are also available, including fencing profiles making the entire groove cross section utilisable as 'installation conduit' for cables. The Aluminium profiles have integral "V" grooves to aid in centring any drilling that may be necessary.

Alloy: 6063 and 6060F22. Natural anodized aluminium 10µm

### Fencing Profile

Designation: JSM A4416  
 Article numbers: 2TLA040037R7000 (cut to length)  
 2TLA040037R7400 (L=6000)  
 Material: Naturally anodized aluminium  
 Dimensions: 16,5x44 mm

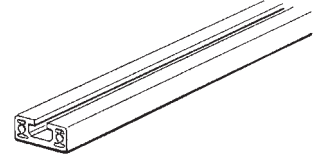
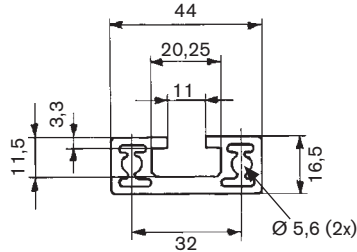

Designation: JSM A4426  
 Article numbers: 2TLA040037R8000 (cut to sizes)  
 2TLA040037R8100 (L=6000)  
 Material: Naturally anodized aluminium  
 Dimensions: 44x26 mm

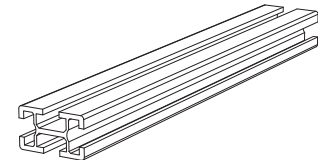
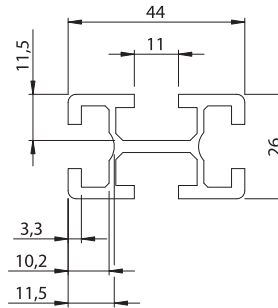

Designation: JSM A44A  
 Article numbers: 2TLA040037R3500 (cut to sizes)  
 2TLA040037R3600 (L=1100)  
 2TLA040037R9800 (L=1400)  
 2TLA040037R3700 (L=2000)  
 2TLA040037R3800 (L=2000)  
 2TLA040037R3900 (L=2400)  
 2TLA040037R4000 (L=2500)  
 2TLA040037R4100 (L=6000)

Material: Natural anodized aluminium  
 Dimensions: 44x44 mm  
 Order Unit: 10 pcs/box

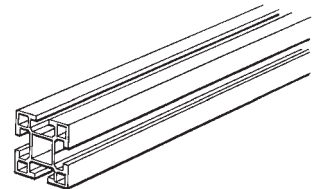
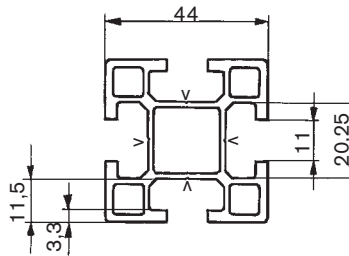

Designation: JSM A4488A  
 Article numbers: 2TLA040037R4200 (cut to sizes)  
 2TLA040037R4300 (L=2000)  
 2TLA040037R4400 (L=2200)  
 2TLA040037R4500 (L=6000)

Material: Natural anodized aluminium  
 Dimensions: 44x88 mm  
 Order Unit: 5 pcs/box

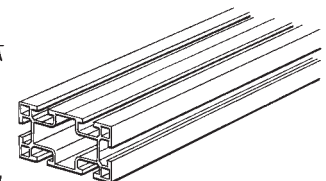
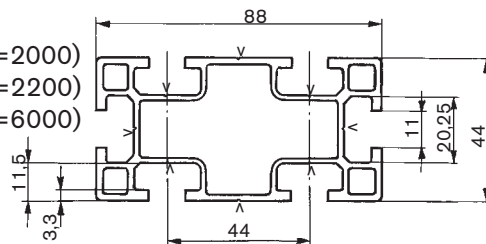

Designation: JSM A8888  
 Article numbers: 2TLA040037R7500 (cut to length)  
 2TLA040037R7900 (L=6000)  
 Material: Natural anodized aluminium  
 Dimensions: 88x88

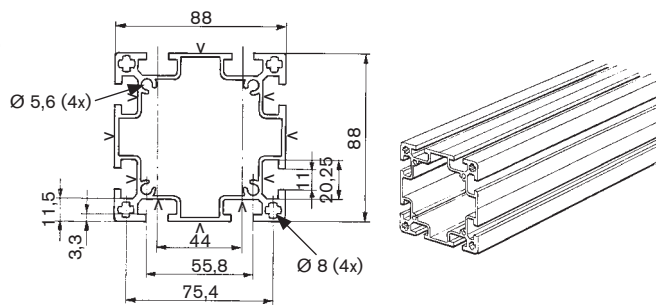

### Technical data – fencing profile

Typ	Vikt (kg/m)	Angular moment		Flexural resistance	
		$I_x$ (mm <sup>4</sup> x10 <sup>4</sup> )	$I_y$ (mm <sup>4</sup> x10 <sup>4</sup> )	$W_x$ (mm <sup>3</sup> x10 <sup>3</sup> )	$W_y$ (mm <sup>3</sup> x10 <sup>3</sup> )
JSM A4416	1.040	1.1	7.6	1.19	3.43
JSM A4426	1,023	3,2	7,4	2,47	3,36
JSM A44A	1.504	12.4	12.4	5.64	5.64
JSM A4488A	2.379	79.6	21.6	18.1	9.8
JSM A8888	3.632	143.0	143.0	32.5	32.5

### Fencing U-Profile

Designation: JSM A12  
 Article numbers: 2TLA040037R2800  
 (cut to sizes, max 2.0 m)  
 2TLA040037R2700 (L=1076)  
 2TLA040037R4600 (L=1476)  
 2TLA040037R4700 (L=2000)  
 Material: Natural anodized aluminium  
 Weight: 0.230 kg/m

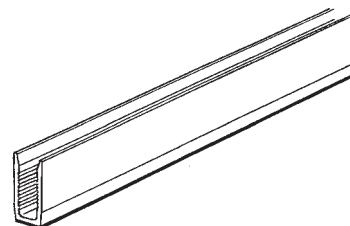
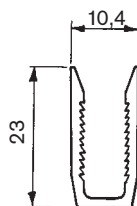

### H-profile

Designation: JSM A13  
 Article numbers: 2TLA040037R5000  
 (JSM A13 cut to sizes)  
 2TLA040037R5100 (L=1076)  
 2TLA040037R5200 (L=1476)  
 2TLA040037R5300 (L=2020)  
 Material: Natural anodized aluminium  
 Weight: 0.452 kg/m

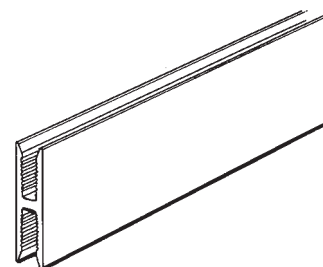
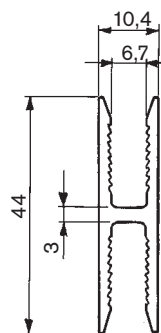

### Guide Rails

Designation: JSM A3130B  
 Article number: 2TLA040037R2600  
 Material: Natural anodized aluminium  
 Holes: c-c = 275 mm, ø = 6 mm  
 Standard Length: 4,0 m (max)  
 Weight: 0.530 kg/m

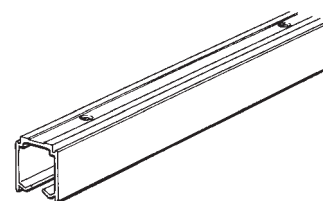
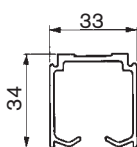

Designation: JSM A56  
 Article number: 2TLA040037R4900  
 (Cut to sizes incl. screws)  
 2TLA040037R0800  
 (Length 2.0 m, incl. screws)  
 2TLA040037R4800  
 (Length 6.0 m, incl. screws)  
 Delivered with: Screw JSM S8E  
 Nut JSM M8B  
 Material: Natural anodized aluminium  
 Holes: c-c = 450 mm,  $\varnothing = 8.5$  mm  
 Standard Length: 2.0; 6.0 m  
 Weight: 1.585 kg/m

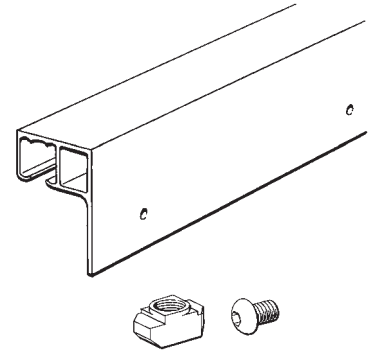
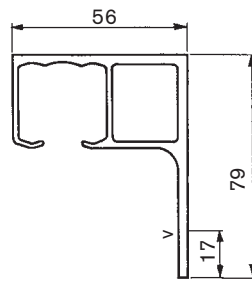

### Cable Ducting

Designation: JSM A25\_  
 Article numbers: 2TLA040037R1300 (JSM A25A)  
 2TLA040037R1400 (JSM A25B)  
 Material: Natural anodized aluminium  
 Dimensions: 44x25 mm  
 Standard Length: 2.0 m  
 JSM A25A: with holes c-c = 500 mm  
 $\varnothing = 5$  mm  
 JSM A25B: without holes  
 Order Unit: 10 pcs/box  
 Weight: 0.545 kg/m JSMA25A  
 0.567 kg/m JSMA25B

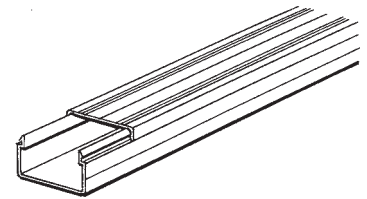
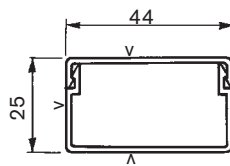

Designation: JSM A60\_  
 Article numbers: 2TLA040037R1500 (JSM A60A)  
 2TLA040037R1600 (JSM A60B)  
 Material: Natural anodized aluminium  
 Dimensions: 44x60 mm  
 Standard Length: 2.0 m  
 JSM A60A: with holes c-c = 500 mm  
 $\varnothing = 5$  mm  
 JSM A60B: without holes  
 Order Unit: 10 pcs/box  
 Weight: 0.923 kg/m JSMA60A  
 0.950 kg/m JSMA60B

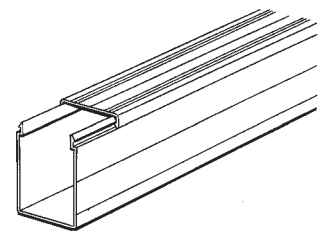
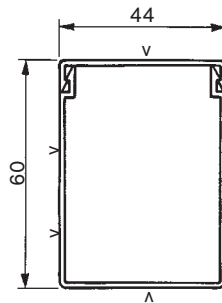

Designation: JSM A88  
 Article number: 2TLA040037R3300  
 Material: Natural anodized aluminium  
 Dimensions: 88x68 mm  
 Standard Length: 2.0 m  
 Weight: 1,844 kg/m

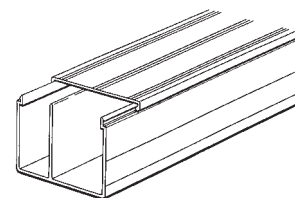
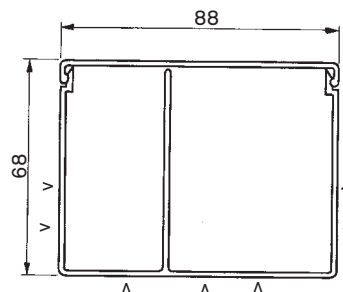

## Cable tie

Designation: JSM X1  
Article number: 2TLA040033R4300  
Pre-assembled with: Screws and Nuts  
Order Unit: 10 pcs/box  
Material: Nylon 6/6 black



## Profiles for installation of acoustic damping

### Profile for 25 mm sound-absorbing panel, JSM YLA25A\_

Designation: JSM AS1  
Article numbers: 2TLA040037R9500  
(cut to length)  
2TLA040037R0900 (L=2000)  
Material: Naturally anodized aluminium  
Dimensions: 29x43 mm  
Weight: 0,545 kg/m

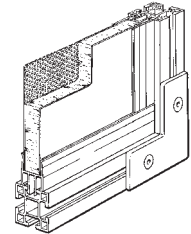
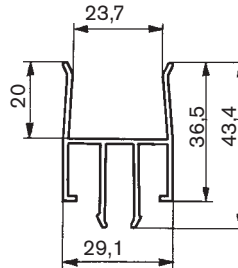

### Profile for 50 mm sound-absorbing panel, JSM YLA50A

Designation: JSM AS3  
Article numbers: 2TLA042021R8000  
(cut to length)  
2TLA042021R8100 (L=6000)  
Material: Naturally anodized aluminium  
Dimensions: 43x56 mm  
Weight: 0,694 kg/m

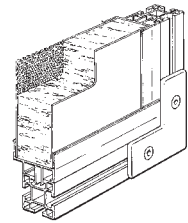
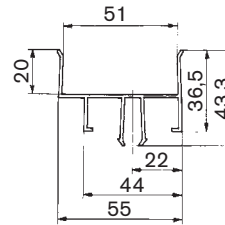

### Profile for double 5mm Polycarbonate panel, JSM YPC5\_

Designation: JSM AS2  
Article numbers: 2TLA040037R9600  
(cut to length)  
2TLA040037R1000 (L=2000)  
Material: Naturally anodized aluminium  
Dimensions: 40x23 mm  
Weight: 0,510 kg/m

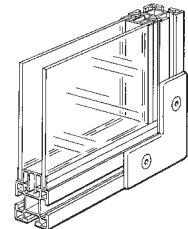
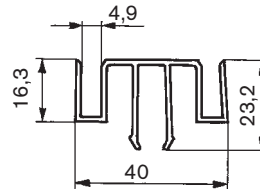

## FITTINGS

ABB Jokab Safety's fencing system is put together with various types of fitting. Uprights are anchored to the floor with floor angle fittings. With a small angle fitting it is possible to hang an electrical enclosure and strengthen the corners of free-standing walls. Corners and joints are constructed with the aid of T, L and I fittings. If angles different to 90° between the fence sections are required, a JSM 35-K angle fitting can be used. This hinge has a distance between centres of 47 mm, which means that the gap between uprights will always be less than 20 mm. According to EN ISO 13857, the minimum permitted protection distance is 120 mm for a gap narrower than 20 mm.

### Floor/Angle fitting

Designation: JSM 39-K  
 Article numbers: 2TLA040030R1400  
 Pre-assembled with: Screw JSM S8C (x 2)  
 Washer 9 x 18 x 1,5 (x 2)  
 Nuts JSM M8B (x 2)  
 Material: Aluminium  
 Quantity: 10 pcs/box

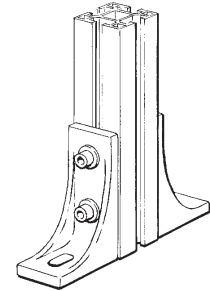
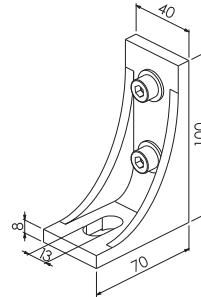

Designation: JSM 30B-K  
 Article number: 2TLA040030R0600  
 Pre-assembled with: Screw JSM S8C (x 2)  
 Washer 9 x 18 1,5 (x 2)  
 Nut JSM M8B (x2)  
 Material: Aluminium  
 Order Unit: 10 pcs/box

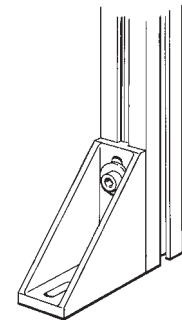
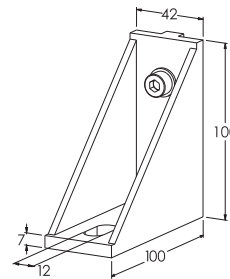

Designation: JSM 30B-K1  
 Article numbers: 2TLA040030R1100  
 Pre-assembled with: Screws JSM S8C (x 4)  
 Washers 9 x 18 x 1,5 (x 4)  
 Nuts JSM M8B (x 4)  
 Washers JSM B8B (x 2)  
 Material: Aluminium  
 Quantity: 10 pcs/box

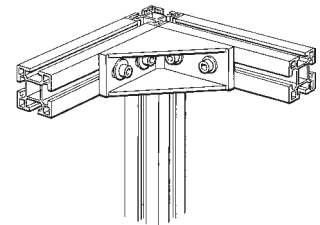
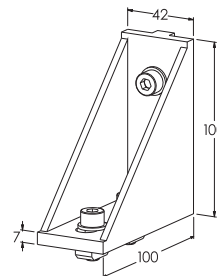

Designation: JSM 36-K1  
 Article number: 2TLA040030R0900  
 Pre-assembled with: Screw JSM S8D (x 3)  
 Nut JSM M8B (x 3)  
 Article number: 2TLA040030R1000  
 Designation: JSM 36-K2  
 Pre-assembled with: Screw JSM S8D (x 3)  
 Nut JSM M8B (x 3)  
 Material: Zinc-plated steel  
 Order Unit: 10 pcs/box

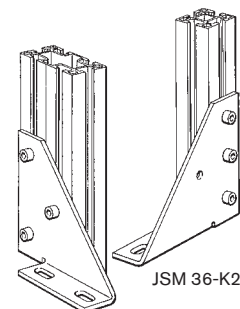
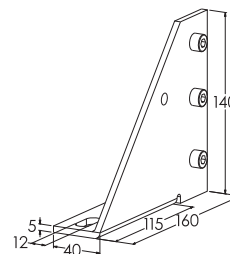

JSM 36-K1

JSM 36-K2



### Small Angle fitting, e.g. Electrical cabinet fitting

Designation: JSM 31B-K  
Two counter sunk holes  
JSM31A1-K  
One counter sunk hole  
Article number: 2TLA040030R1300 (JSM 31B-K)  
2TLA040030R0400 (JSM 31A1-K)  
Pre-assembled with: Screw JSM S8C  
Nut JSM M8B  
Material: Aluminium  
Order unit: 10 pcs/box

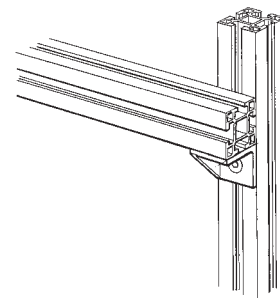
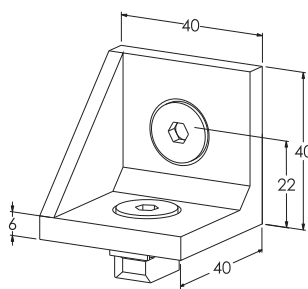

### L-bracket

Designation: JSM 32B-K  
Article number: 2TLA040030R0700  
Pre-assembled with: Screw JSM S8A  
Nut JSM M8B  
Material: Aluminium  
Order Unit: 10 pcs/box

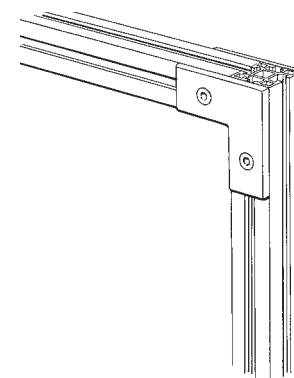
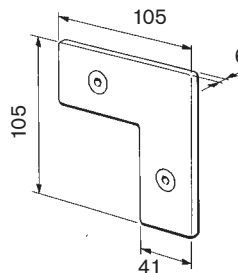

### T-bracket

Designation: JSM 33B-K  
Article number: 2TLA040030R0800  
Pre-assembled with: Screw JSM S8A  
Nut JSM M8B  
Material: Aluminium  
Order Unit: 10 pcs/box

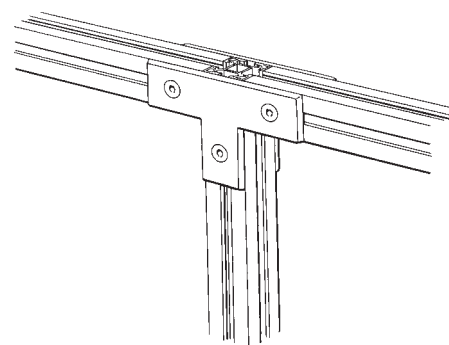
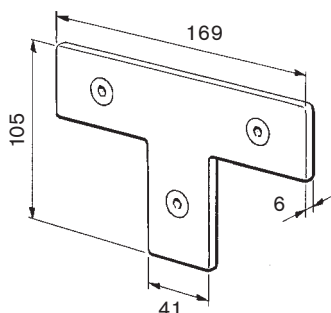

### I-bracket, joint

Designation: JSM 34B-K  
Article number: 2TLA040030R1500  
Pre-assembled with: Screw JSM S8A  
Nut JSM M8B  
Material: Aluminium  
Order Unit: 10 pcs/box

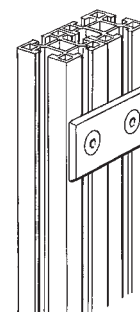
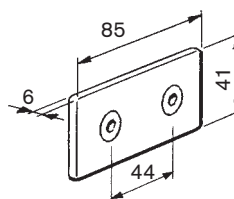

### Distance screw

Designation: JSM 37  
Article number: 2TLA040033R3100  
Material: Zinc-plated steel  
Order unit: 100 pcs/box

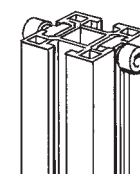
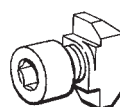

## Angle bracket

Designation: JSM D1C Hinge  
Article number: 2TLA040033R4800  
Pre-assembled with: JSM M8B  
JSM B8C  
JSM S8A  
Material: Polyamide, glass fibre reinforced  
Color: Black  
Order unit: 2pcs/bag, 10pcs/box

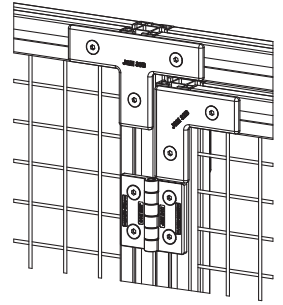
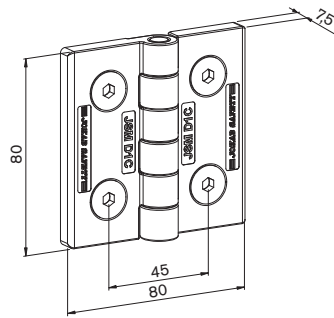

Designation: JSM 35-K  
Article number: 2TLA040033R1400  
Pre-assembled with: Screw JSM S6A  
Nut JSM M6B  
Material: Zinc-plated steel  
Hole: c-c = 47 mm  
Order unit: 2 pcs/box

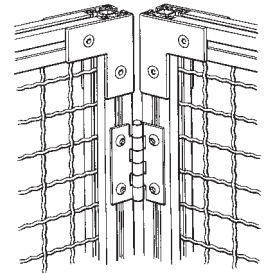
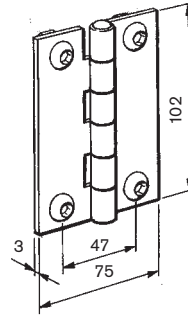

**Note!** The JSM 35-K must only be used for making fence angles.

## DOOR COMPONENTS

To mount conventional doors a hinge is available which permits an opening angle of 180°. For mounting a sliding door, guide rails and suspension wheels are utilised. Other sliding elements make it possible to build different types of hatches. Guide rollers, for wide and heavy doors, door closers, fittings for sensors/switches etc are also available.

**Conventional Door**

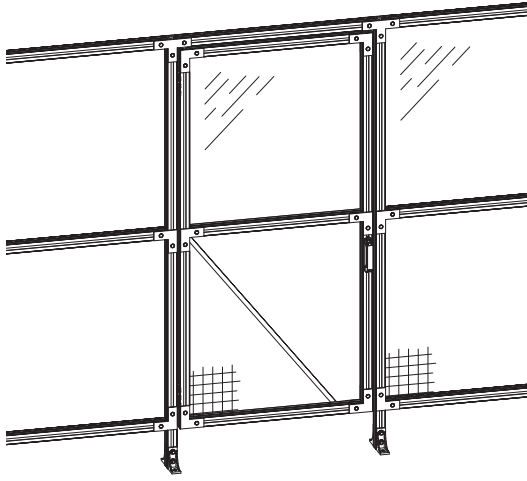

**Sliding Door**

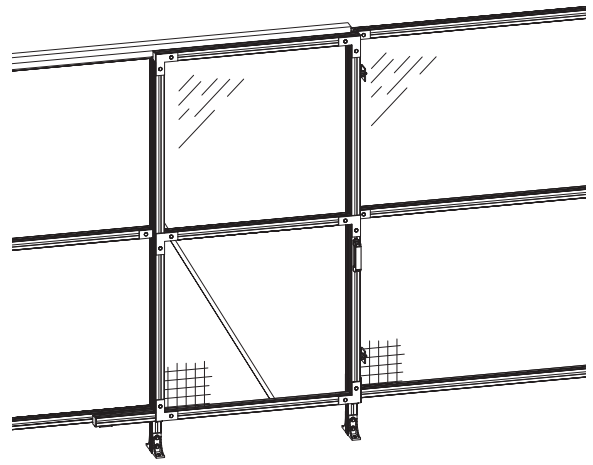

**Hatch**

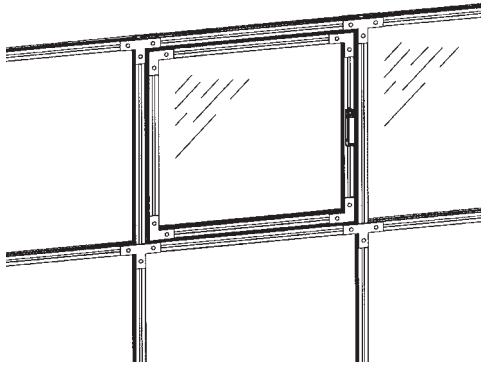

**Double Hatch**

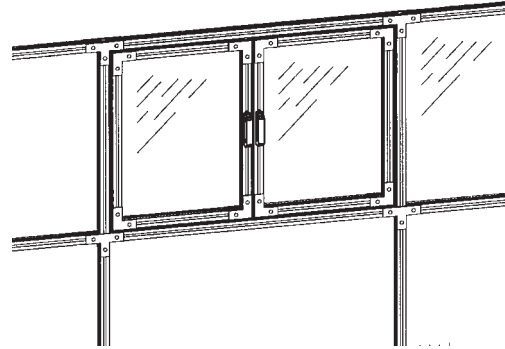

**Folding Hatch**

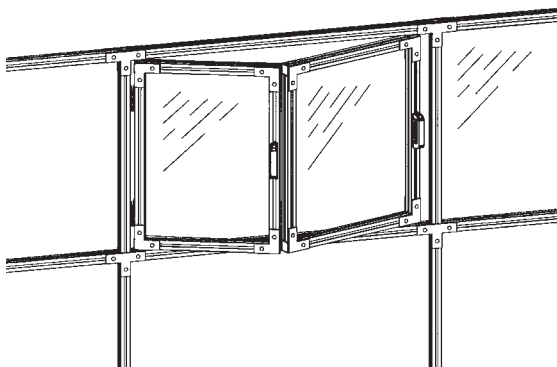

**Sliding Hatch**

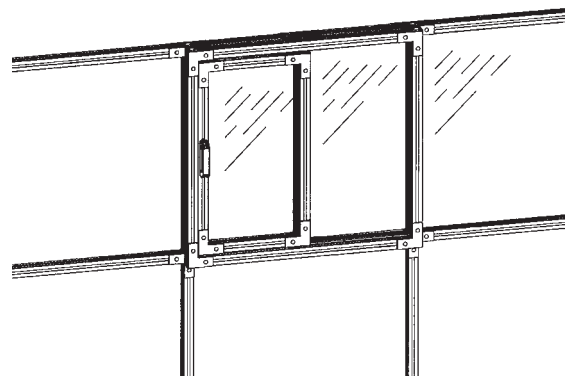

## Hinge kit

Designation: JSM D1C Hinge  
 Article number: 2TLA040033R4800  
 Pre-assembled with: JSM M8B  
 JSM B8C  
 JSM S8A  
 Material: Polyamide, glass fibre reinforced  
 Color: Black  
 Order unit: 2pcs/bag, 10pcs/box

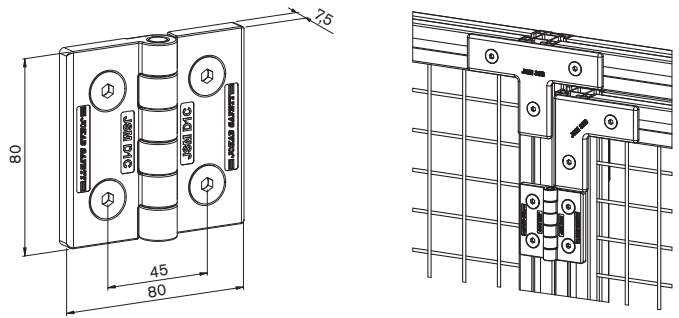

Designation: JSM D1A Hinge  
 Article number: 2TLA040033R1500  
 Pre-assembled with: Screw JSM S6A  
 Nut JSM M6B  
 Material: Zinc-plated steel  
 Fixing Holes : c-c = 62 mm  
 Order Unit: 2 pcs/box

**Note!** JSM D1A must not be used as a fencing angle fitting because its gap can exceed 20 mm.

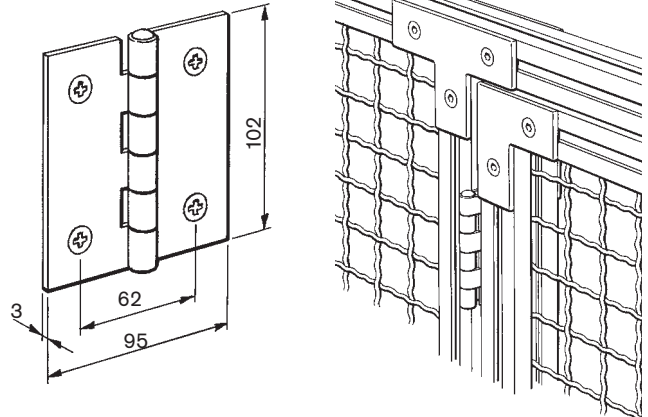

Designation: JSM D1B Spring hinge  
 Article numbers: 2TLA042020R4700  
 Pre-assembled with: Spacer plate, screws & nuts  
 Material: Zinc-plated steel

**NOTE!** The door gap will be 28 mm when installed.

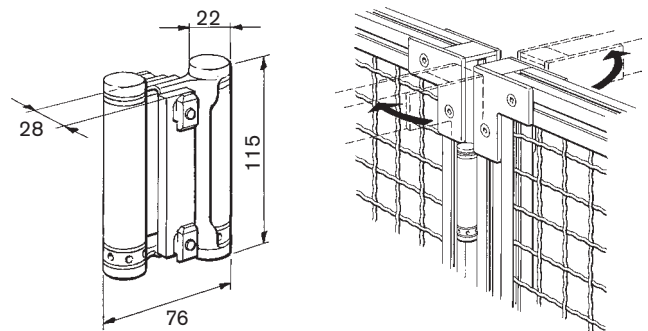

## Handle

Designation: JSM D2 Handle  
 Article number: 2TLA040033R0100  
 Pre-assembled with: Screw JSM S8D  
 Nut JSM M8B  
 Material: Thermoplastic, black

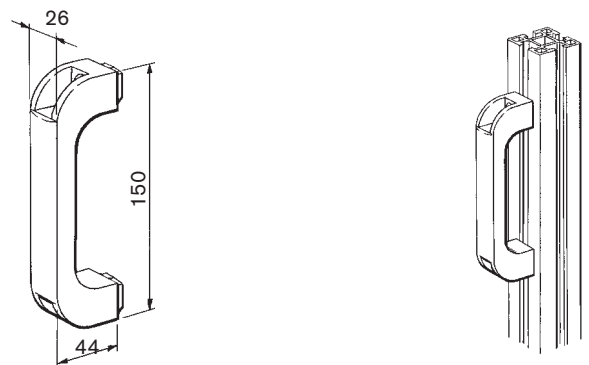

Designation: JSM D18 Handle  
 Article number: 2TLA042020R5000  
 Material  
 Handle: Thermoplastic, black  
 Fittings: Aluminum  
 Pre-assembled with: Screws and Nuts

Suitable for sliding door on the inside of the fence.

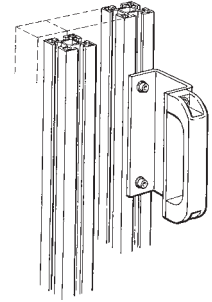
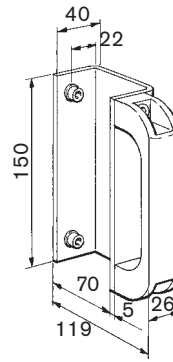

### Door closer

Designation: JSM D3  
 (conventional door)  
 Material: Door closer - steel  
 Bracket - Aluminum  
 Article number: 2TLA040033R0200  
 Pre-assembled with: Screws and Nuts  
 Designation: JSM D19 (sliding door)  
 Article number: 2TLA042020R5600  
 Material: Zinc-plated steel  
 Pre-assembled with: Screws and Nuts

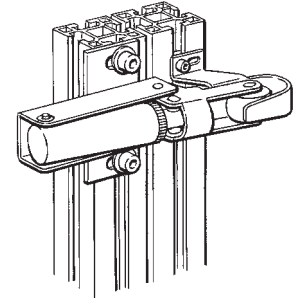
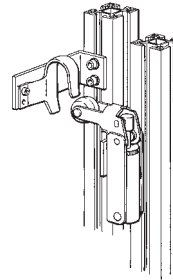
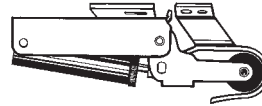

### Gas spring

Designation: Gas spring including mount  
 Article numbers: 2TLA042024R1000  
 Stroke length: 300 mm  
 Material: Steel  
 Pre-assembled with: Screws and Nuts

Designation: JSM D22A Gas spring including mount  
 Article numbers: 2TLA042024R1100  
 Stroke length: 350 mm  
 Material: Steel  
 Pre-assembled with: Screws and Nuts

*Fixing details included:*  
 Side fastener (2TLA042021R2700)  
 U fitting (2TLA042021R2800)

Specify the required force when ordering

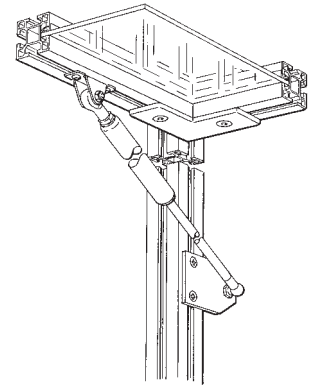
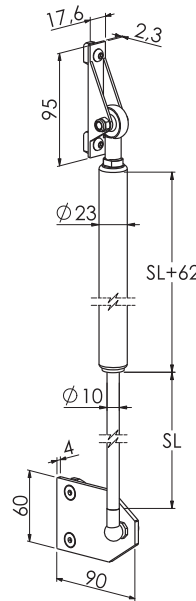

### Securing plate for padlock

Designation: JSM D17 Bracket for Padlock  
 hasp  
 Article number: 2TLA040020R2200  
 Material: Zinc-plated steel

**Note!** Two pieces are required for one complete unit.

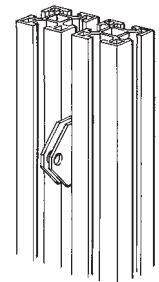
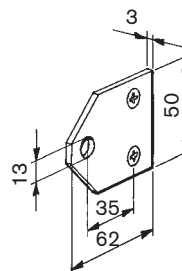

## Ball Catch

Designation: JSM D11B (conventional door)  
 Article number: 2TLA040033R4100  
 Pre-assembled with: Screws and Nuts  
 Material  
 Brackets: Aluminium  
 Ball Catch: Nickel-plated brass

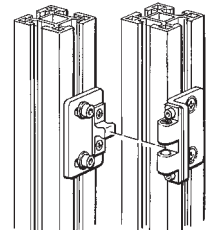
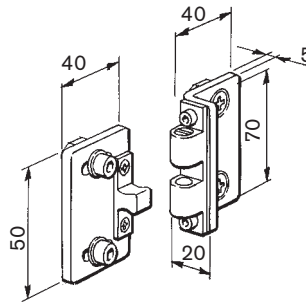

Designation: JSM D11C (sliding door)  
 Article number: 2TLA040033R4200  
 Pre-assembled with: Screws and Nuts  
 Material  
 Brackets: Aluminium  
 Ball Catch: Nickel-plated brass

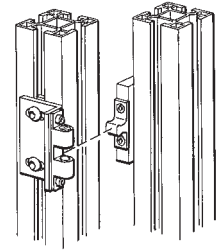
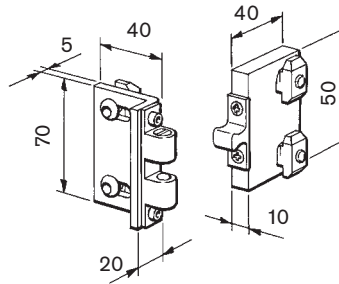

Designation: JSM D11D (folding door)  
 Article number: 2TLA042020R5200  
 Pre-assembled with: Screws and Nuts  
 Material  
 Brackets: Aluminium  
 Ball Catch: Nickel-plated brass

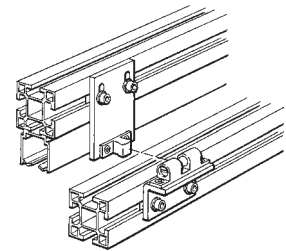
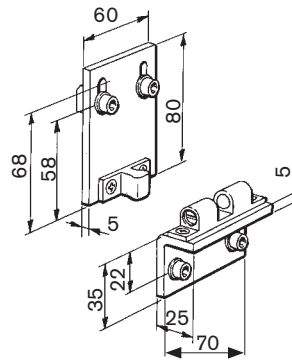



## Upper Door bolt

Upper Door bolt  
Designation: JSM D10A  
Article number: 2TLA040033R2100  
Pre-assembled with: Screws and Nuts  
Material  
Brackets: Zinc-plated steel  
Rod: Stainless steel

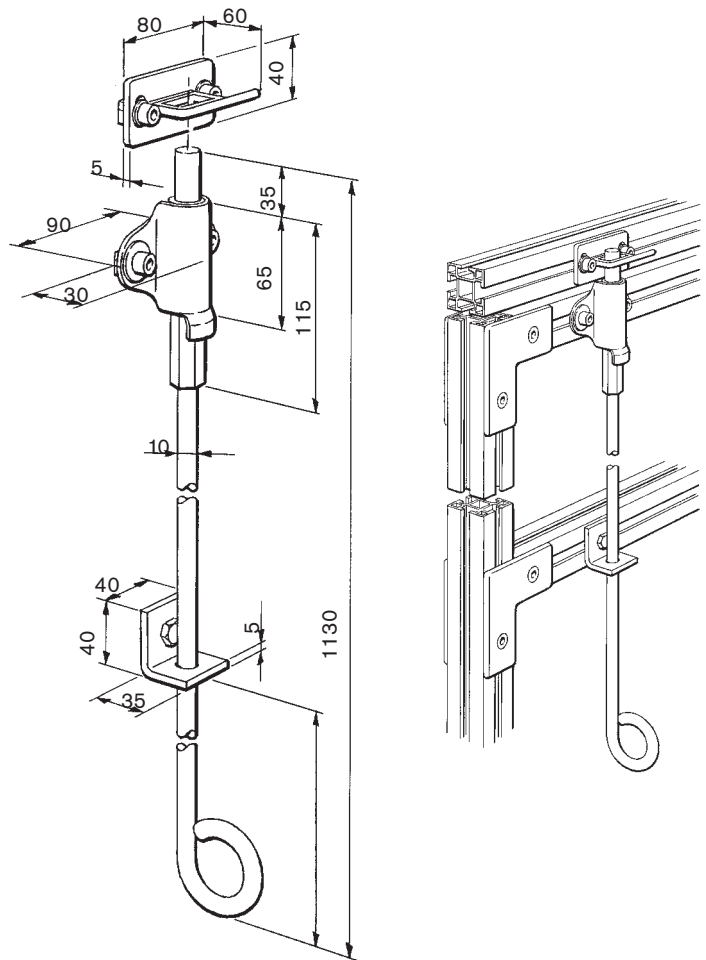

## Lower Door bolt

Designation: JSM D10  
Article number: 2TLA040033R2000  
Pre-assembled with: Screws and Nuts  
Material  
Brackets: Zinc-plated steel  
Rod: Stainless steel

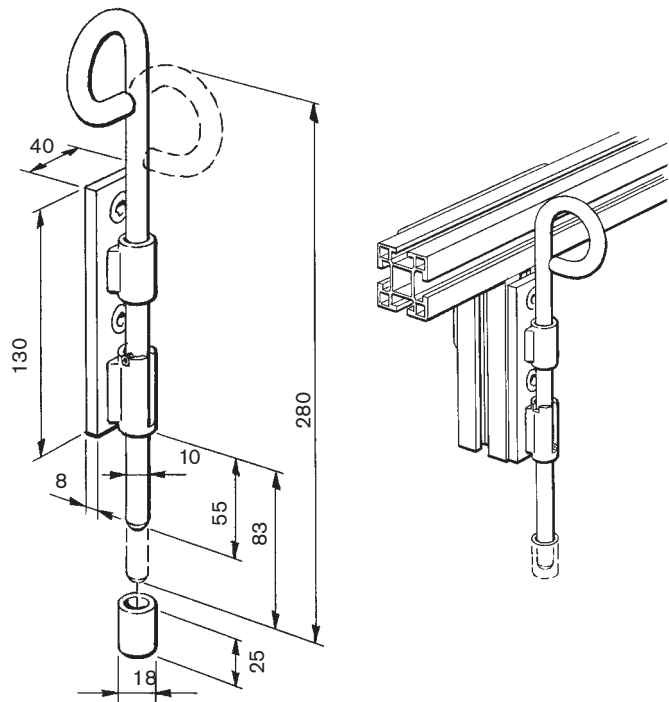

## Lower Door bolt

Lower Door bolt

Designation: JSM D10B  
 Article number: 2TLA040033R3800  
 Pre-assembled with: Screws and Nuts  
 Material  
 Brackets: Zinc-plated steel  
 Rod: Stainless steel

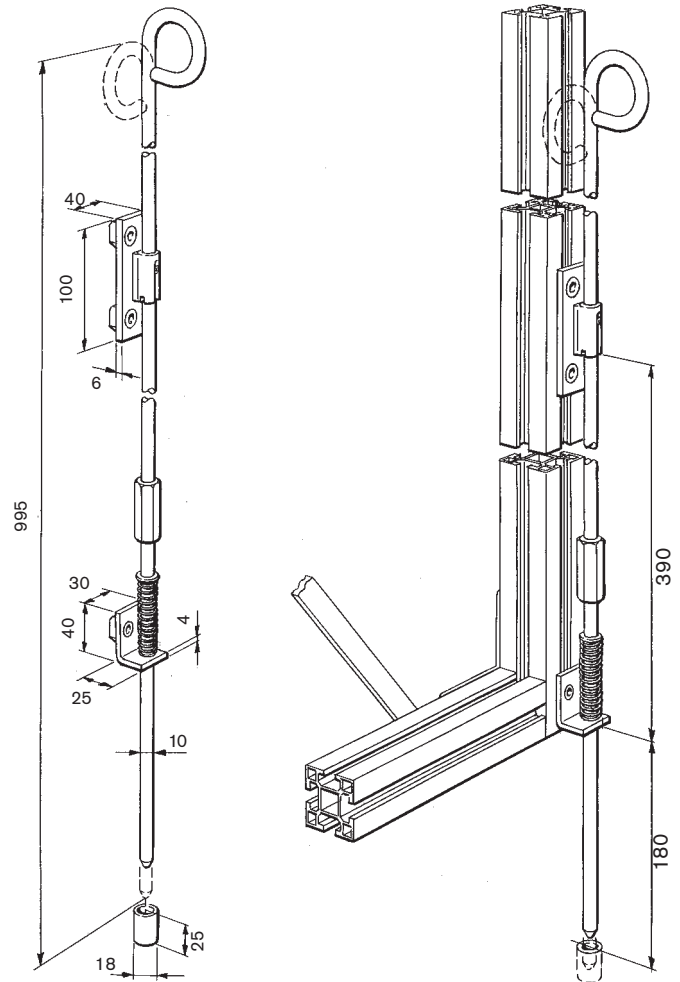

## Cam lock

**Cam lock**

Designation: JSM D15  
 Article number: 2TLA040033R3900  
 Pre-assembled with: Screws and Nuts  
 Material  
 Brackets: Aluminium  
 Lockunit: Polyamide black

Delivered without key.

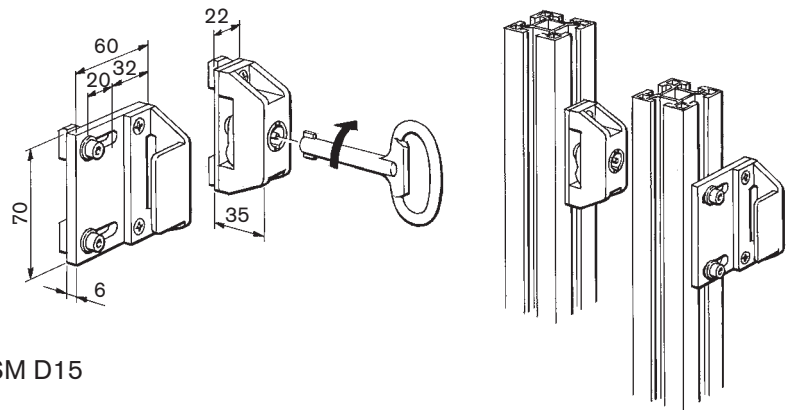

**Key to cam lock**

Designation: JSM D16 for cam lock JSM D15  
 Article number: 2TLA040033R4400  
 Material: Zinc, black

## Sliding bolt for Eden

Designation: JSM D20 (for hinged door)  
Article numbers: 2TLA020302R1000  
Material: Steel, painted yellow

Supplied without an Eden

*For installation on hinged doors.*

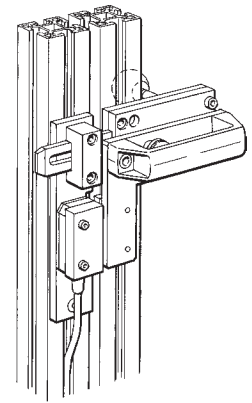
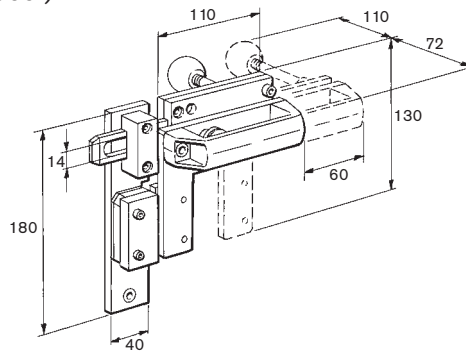

## Magne 1A mount

Designation: JSM D21  
Article numbers: 2TLA042023R0000  
Material: Anodised aluminium

Supplied without Magne 1A Magnetic lock

*For installation on hinged doors*

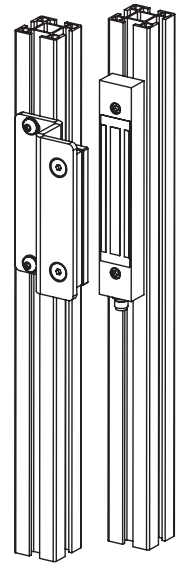
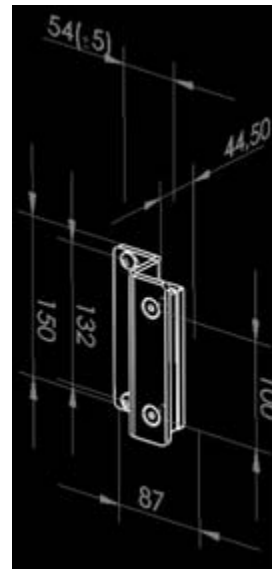

## Door stop

Designation: JSM D13A  
Article number: 2TLA040033R2600  
Pre-assembled with: Screws and Nuts  
Material: Natural anodized aluminium

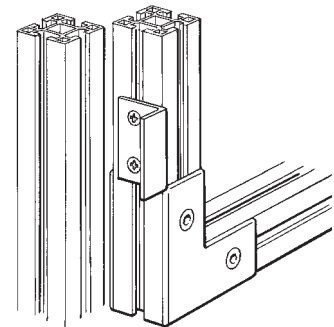
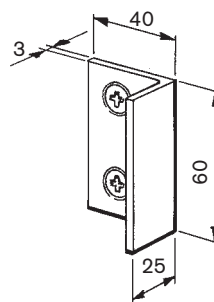

Designation: JSM D13  
Article number: 2TLA040033R2500  
Pre-assembled with: Screws, Nuts and vibration damper  
Material: Zinc-plated steel

*For mounting on vertical profiles.*

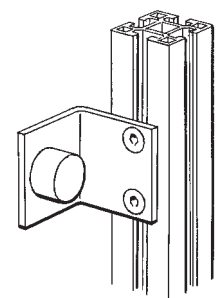
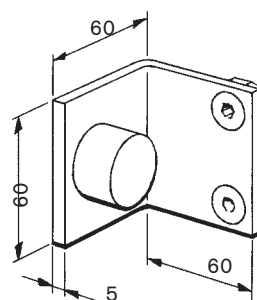

Designation: JSM D13B  
 Article number: 2TLA040033R2700  
 Pre-assembled with: Screws, Nuts and vibration damper  
 Material: Zinc-plated steel

*For mounting on horizontal profiles.*

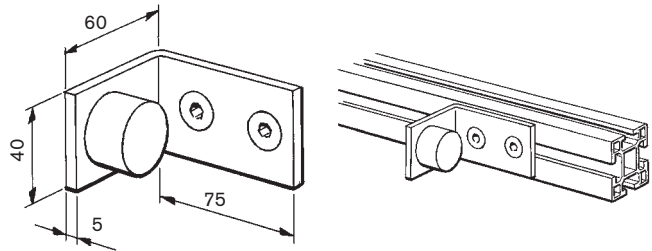

### Suspension wheels

Designation: JSM D5  
 Article number: 2TLA040033R0400

For aluminium profile guide rails JSM A3130B and JSM A56

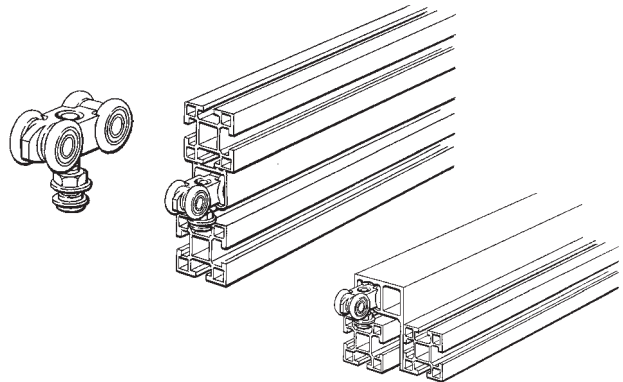

### Sliding elements

#### Sliding element, (rectangular)

Designation: JSM D6  
 Article number: 2TLA040033R0500  
 Pre-assembled with: Screw and Nut  
 Material: Polyamid

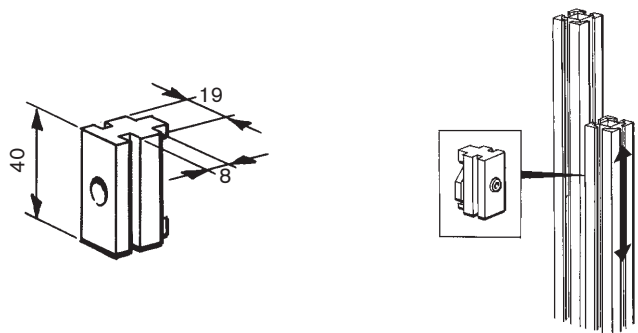

#### Sliding element, (round)

Designation: JSM D7  
 Article number: 2TLA040033R0600  
 Pre-assembled with: Screw and Nut  
 Material: Polyamid

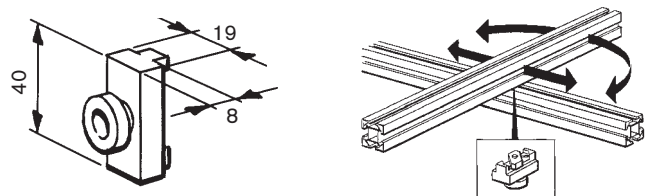

#### Sliding element, (guide)

Designation: JSM D8  
 Article number: 2TLA040033R0700  
 Pre-assembled with: Screw and Nut  
 Material: Polyamid

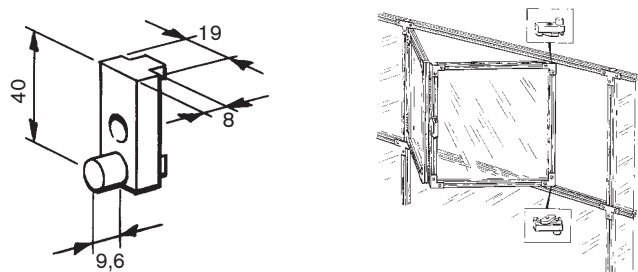

## Guide Components for Sliding Door

### Guide Bracket for Sliding Door

Designation: JSM D12  
Article number: 2TLA040033R2200  
Pre-assembled with: Screws and Nuts  
Material: Aluminium and PA6-6

*For mounting on vertical profiles.*

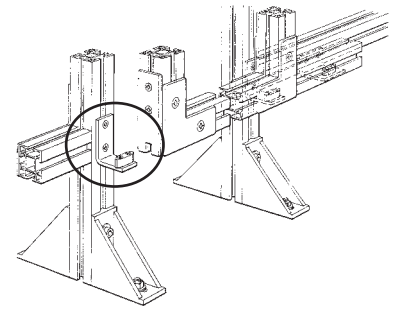
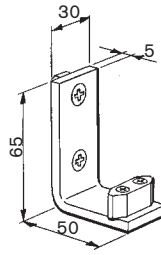

### Guide Bracket for Sliding Door

Designation: JSM D12A  
Article number: 2TLA040033R2300  
Pre-assembled with: Screws and Nuts  
Material: Aluminium and PA6-6

*For mounting on horizontal profiles.*

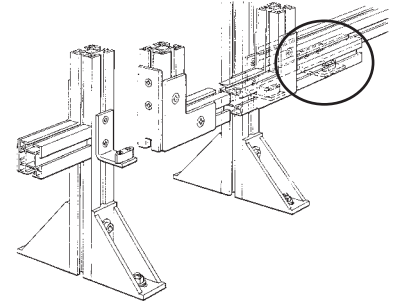
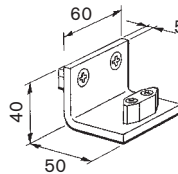

### Bracket for Guide Pin

Designation: JSM D12B  
Article number: 2TLA040033R2400  
Pre-assembled with: Screws and Nuts  
Material: Aluminium

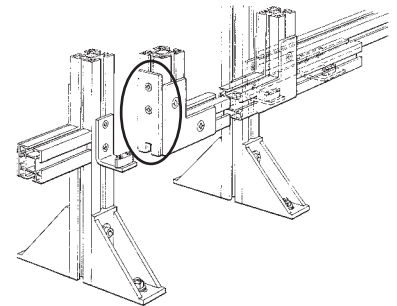
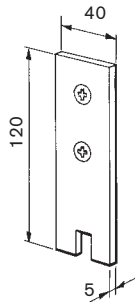

## Guide roller

### Guide roller for conventional door with locking mechanism

Designation: JSM D9  
JSM D9-K - Pre-assembled with angle bracket  
Article numbers: 2TLA040033R0800 (JSM D9)  
2TLA040033R1100 (JSM D9-K)  
Diameter: 75 mm  
Max. load: 60 kg

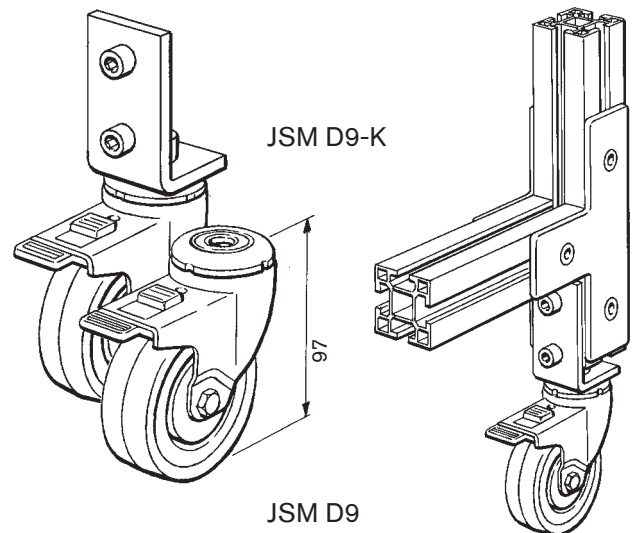

### Guide roller for sliding door

Designation: JSM D9A  
JSM D9A-K - Pre-assembled  
with angle bracket

Article numbers: 2TLA040033R1200 (JSM D9A)  
2TLA040033R1300 (JSM D9A-K)

Diameter: 75 mm  
Max. load: 70 kg

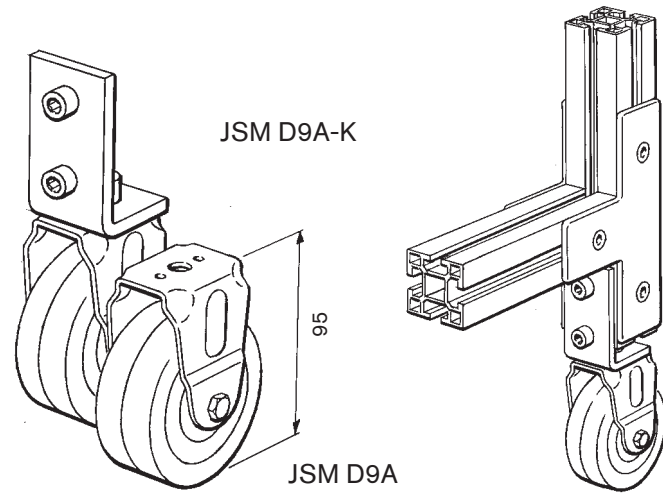

### Diagonal bar for door

Designation: JSM D14  
Article numbers: 2TLA040033R2800  
Length: 1160 mm  
Pre-assembled with: Screws and Nuts  
Material: Naturally anodized aluminium

Designation: JSM D14A  
Article numbers: 2TLA042021R7300  
Length: 400 mm  
Pre-assembled with: Screws and Nuts  
Material: Naturally anodized aluminium

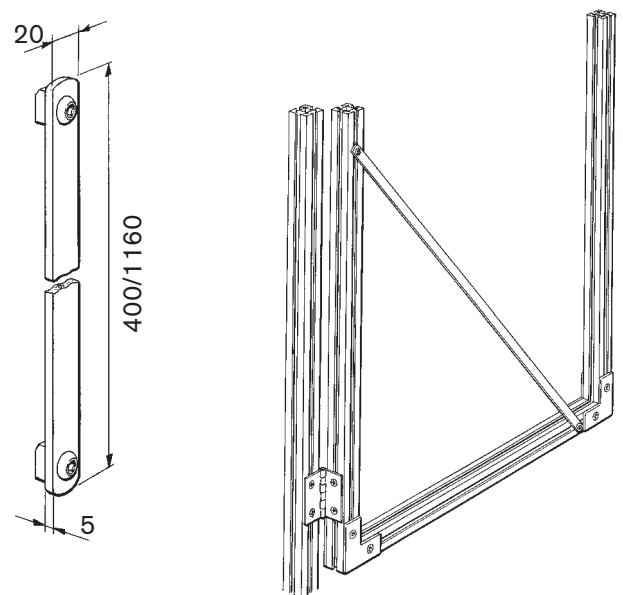



## FITTINGS FOR SWITCHES

### Eden fittings

#### Fittings for Eden, adapted for sliding and conventional doors

Designation: JSM D4H  
Article number: 2TLA040033R3600  
Pre-assembled with: Screws and Nuts  
Material: Aluminium

#### Note!

Two fittings are needed for a complete Eden.

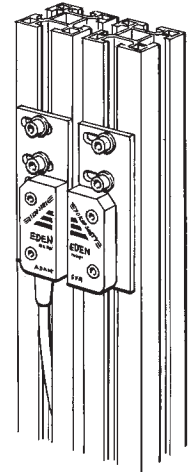
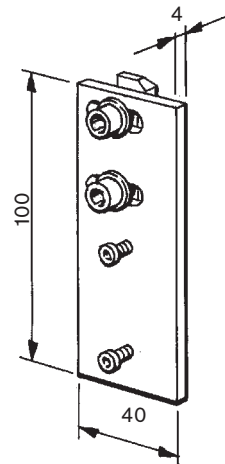

#### Eden Fitting for sliding door (flush with fence)

Designation: JSM D4J  
Article number: 2TLA042020R4000  
Pre-assembled with: Screws and Nuts  
Material: Aluminium

Note! One JSM D4H and one JSM D4J are needed for a complete unit.

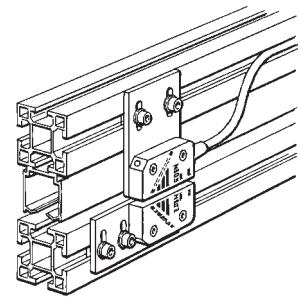
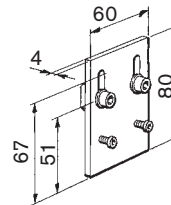

### Fittings for JSNY5 Interlock Switches

#### Conventional opening door Interlock Switch Fittings.

Designation: JSM D4A  
Article number: 2TLA040033R0900  
Pre-assembled with: Screws and Nuts  
Material: Zinc-plated steel

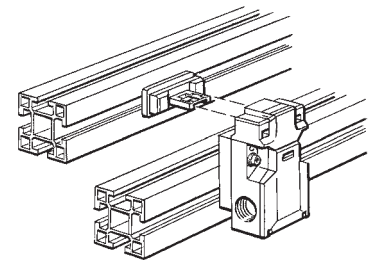
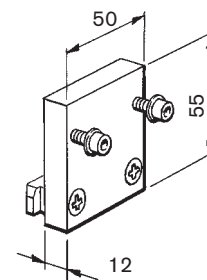
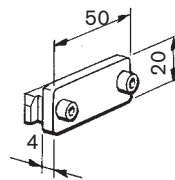

#### Conventional opening door Interlock Switch Fittings.

Designation: JSM D4AA  
Article number: 2TLA040033R3400  
Pre-assembled with: Screws and Nuts  
Material: Zinc-plated steel

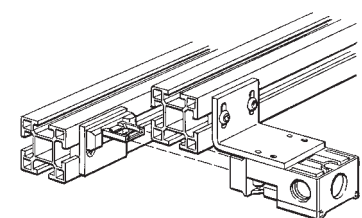
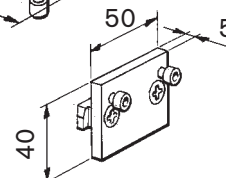
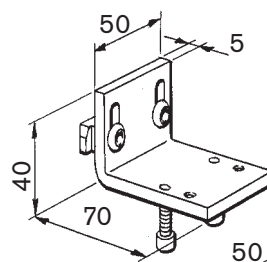

### Sliding Door Interlock Switch Fittings

Designation: JSM D4B  
Article number: 2TLA040033R1000  
Pre-assembled with: Screws and Nuts  
Material: Zinc-plated steel

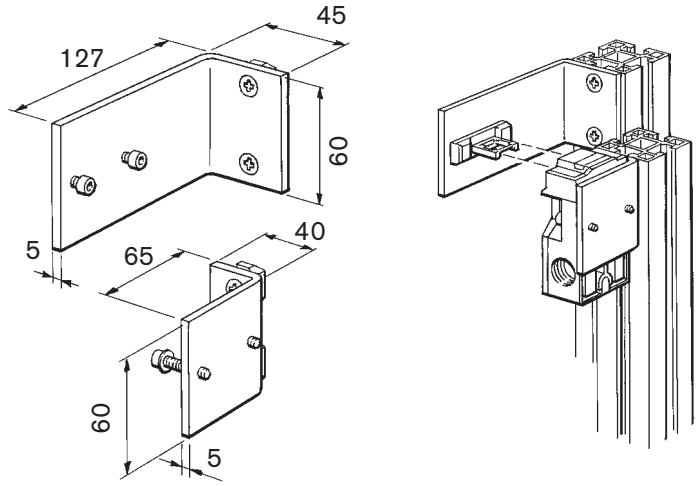

### Fittings for Magnet Switches JSNY7

#### Hinged door Magnet Switch Fittings

Designation: JSM D4E  
Article number: 2TLA040033R1800  
Pre-assembled with: Screws and Nuts  
Material: Aluminium

**Note!** Two fittings are needed for a complete JSNY7.

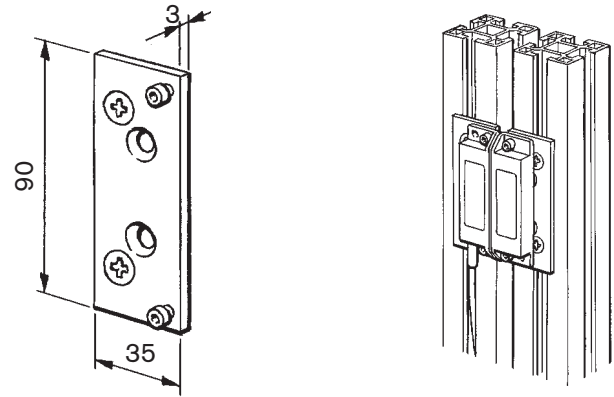

#### Sliding Door Magnet Switch Fittings

Designation: JSM D4G  
Article number: 2TLA040033R3300  
Pre-assembled with: Screws and Nuts  
Material: Aluminium

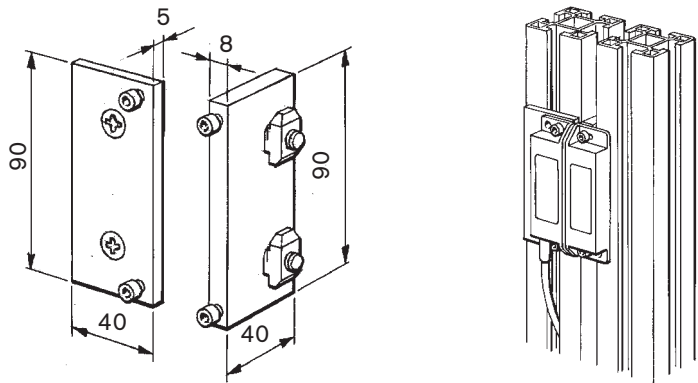

## Fittings for Interlock Switches JSNY8 and JSNY9

### Sliding Door Interlock Switch for JSNY8 Fittings.

Designation: JSM D4D  
Article numbers: 2TLA040033R1700  
Pre-assembled with: Screws and Nuts  
Material: Zinc-plated steel

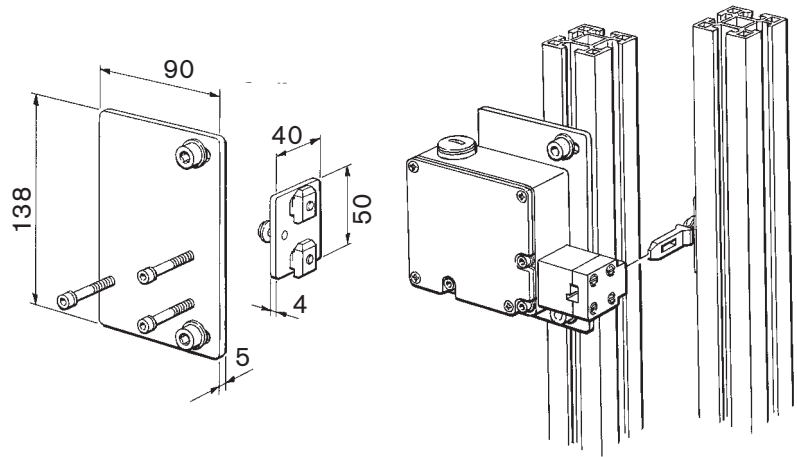

### Conventional opening door Interlock Switch Fittings for JSNY9 and JSNY8

Designation: JSM D4C  
Article number: 2TLA040033R1600  
Pre-assembled with: Screws and Nuts  
Material: Zinc-plated steel

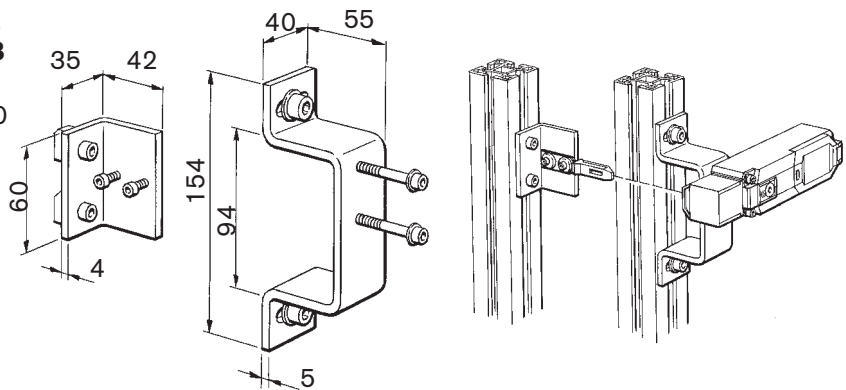

### Sliding door Interlock Switch Fittings for JSNY9

Designation: JSM D4F  
Article number: 2TLA040033R3000  
Pre-assembled with: Screws and Nuts  
Material: Zinc-plated steel

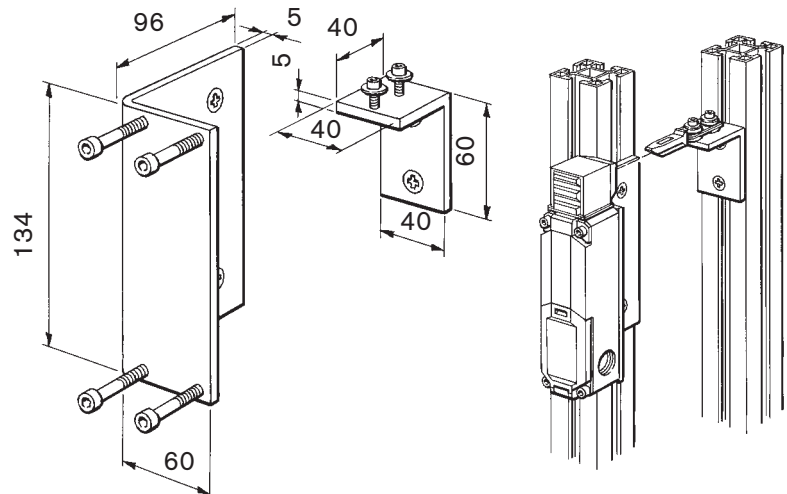

## TERMINAL CAPS AND STRIPS

Terminal caps are available to cover profile ends, thus eliminating sharp edges. Strips are also available, both narrow and wide, to cover the side of the fencing profile.

### Terminal Caps

#### Terminal Cap for JSM A44A

Designation: JSM L1A (yellow)  
JSM L1B (grey)  
Article numbers: 2TLA040034R0000 (JSM L1A)  
2TLA040034R0300 (JSM L1B)  
Material: Polyamide  
Dimensions: 44x44 mm

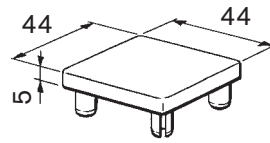

#### Terminal Cap for JSM A4488A

Designation: JSM L4A (yellow)  
JSM L4B (grey)  
Article numbers: 2TLA040034R0400 (JSM L4A)  
2TLA040034R0500 (JSM L4B)  
Material: Polyamide  
Dimensions: 44x88 mm

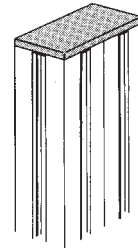
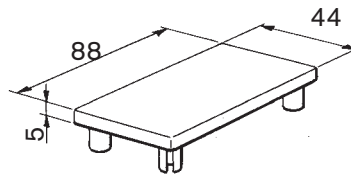

#### Terminal Cap for JSM A25

Designation: JSM L2  
Article number: 2TLA040034R0100  
Material: Polyamide, grey  
Dimensions: 44x25 mm

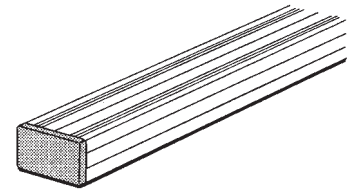
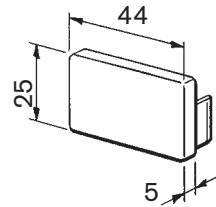

#### Terminal Cap for JSM A60

Designation: JSM L3  
Article number: 2TLA040034R0200  
Material: Polyamide, grey  
Dimensions: 44x60 mm

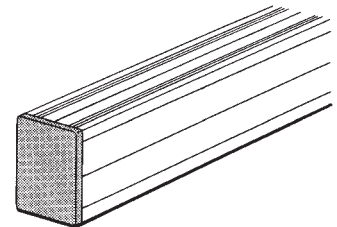
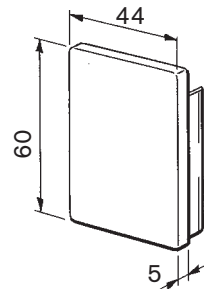

### Cover Strip

#### Narrow Cover Strip, for JSM A44A, JSM A44A, JSM A4488A and JSM A8888

Designation: JSM T3: Yellow\*  
JSMT3B: Grey\*  
Article numbers: 2TLA040037R3100 (JSM T3A)  
2TLA040037R3200 (JSM T3B)  
Material: ABS  
Dimensions: 16 mm  
Order Unit: 2 m

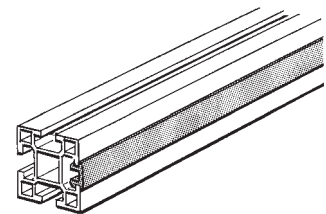
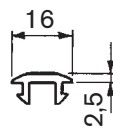

#### Wide Cover Strip, for JSM A44A, JSM A44A, JSM A4488A and JSM A8888



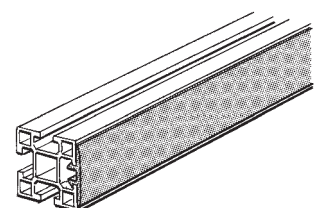
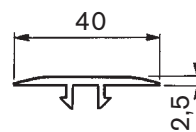







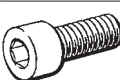

Designation: JSM T2A  
Article number: 2TLA040037R1900  
Material: PVC, yellow\*, soft material  
Dimensions: 40 mm  
Order Unit: 25 m/coil



\* Other colours available upon request.

## ACCESSORIES

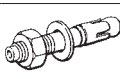
All fittings and door components are delivered complete with screws, washers and nuts pre-mounted.  
For cable ducting the screws, S5B, and nuts, M5B, have to be ordered separately (4 pcs/2m).

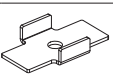
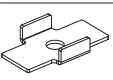
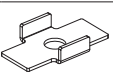
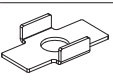
Designation	Article number	Description	Dimension	Material	Order Unit
JSM S5B 	2TLA041039R0100	Screw to cable ducting	M5x12	Zinc Plated Steel	100 pcs/box
JSM S6A 	2TLA041039R0200	Screw for hinge cross-slotted Z (pozidrive)	M6x12	Zinc Plated Steel	100 pcs/box
JSM S8A 	2TLA041019R0000	Fixing screw countersunk.	M8x16	Zinc Plated, Dacrolit	100 pcs/box
JSM S8C 	2TLA041014R0200	Fixing screw for floor fitting and small angle	M8x20	Zinc Plated Steel	100 pcs/box
JSM S8D 	2TLA041014R0100	Fixing screw	M8x16	Zinc Plated Steel	100 pcs/box
JSM S8E 	2TLA041019R0100	Fixing screw for Guide rail JSM A56	M8x12	Zinc Plated Steel	100 pcs/box
JSM M4B 	2TLA040035R0700	Locking nut	M4	Zinc Plated Steel	100 pcs/box
JSM M5B 	2TLA040035R0400	Locking nut	M5	Zinc Plated Steel	100 pcs/box
JSM M6B 	2TLA040035R0500	Locking nut	M6	Zinc Plated Steel	100 pcs/box
JSM M8B 	2TLA040035R0600	Locking nut	M8	Zinc Plated Steel	100 pcs/box
JSM X1 	2TLA040033R4300	Cable tie	2,5–7,8 mm	Nylon black UV-resistant	10 pcs/box
JSM X2 	2TLA041900R4300	Expansion-shell bolt	M10x68	Zinc Plated Steel	50 pcs/box
JSM X3 	2TLA041910R0000	Window cleaning fluid (Antistatic) for polycarbonate sheets. Actuator head 0.5 L.			per can
JSM X4 	2TLA041911R0100	Mesh clipping tool	L=300		each
JSM B4C 	2TLA040035R5000	Centring washer steel	Ø4,2	Zinc Plated Steel	100 pcs/box
JSM B5C 	2TLA040035R5100	Centring washer steel	Ø5,2	Zinc Plated Steel	100 pcs/box
JSM B6C 	2TLA040035R5200	Centring washer steel	Ø6,2	Zinc Plated Steel	100 pcs/box
JSM B8C 	2TLA040035R5300	Centring washer steel	Ø8,2	Zinc Plated Steel	100 pcs/box

## SURFACES

The choice of net and surfaces depends, among other things, on the protection distance. In the case of netting, a minimum distance of 200 mm (for anyone aged 14 or older) with a mesh size of 40x40 mm in accordance with EN ISO 13857. For closer protection distances and for noise reduction, solid panels are used. Panels are available in different materials. For protection of welding cells, polycarbonate welding transparencies are used.

### Welded net

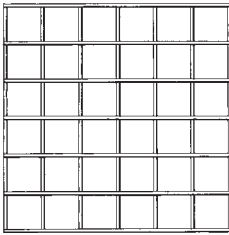

Designation: JSM YN40W\_/WE\_  
 Stitch: 40x40 mm  
 Thread: 3,5 mm

Article no.	Name	Material	Dimensions	Type
2TLA040040R1300	JSM YN40W1	Steel, black powder coated	2020 x 864 mm	Welded
2TLA040040R1400	JSM YN40W2	Steel, black powder coated	1074 x 1816 mm	Welded
2TLA040040R1500	JSM YN40W3	Steel, black powder coated	1074 x 2016 mm	Welded
2TLA040040R2000	JSM YN40W4	Steel, black powder coated	1474 x 2016 mm	Welded
2TLA040040R2100	JSM YN40W5	Steel, black powder coated	1474 x 1816 mm	Welded
2TLA040040R2600	JSM YN40W6	Steel, black powder coated	2020 x 754 mm	Welded
2TLA040040R2700	JSM YN40W7	Steel, black powder coated	2020 x 1174 mm	Welded
2TLA040040R1600	JSM YN40W9	Steel, black powder coated	Cut to size	Welded
2TLA040040R2800	JSM YN40W10	Steel, black powder coated	1474 x 1216 mm	Welded
2TLA040040R2900	JSM YN40W11	Steel, black powder coated	1074 x 1216 mm	Welded
2TLA040040R2500	JSM YN40WE1	Stainless steel, SS 2333	2020 x 864 mm	Welded
2TLA040040R1800	JSM YN40WE2	Stainless steel, SS 2333	1074 x 1816 mm	Welded
2TLA040040R1900	JSM YN40WE9	Stainless steel, SS 2333	Cut to size	Welded

Other colours, hot-dip galvanized mesh or woven wire mesh netting supplied on request.

### Net locking for welded netting with outer wire

Designation: JSM NL2  
 Article numbers: 2TLA040031R0600  
 Material: PA/ABS  
 Quantity: 100 pcs/box

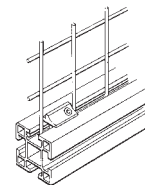
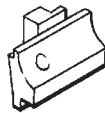

### Net locking for welded and woven wire mesh netting, with or without outer wires

Designation: JSM NL3  
 Article numbers: 2TLA040031R0800  
 Pre-assembled with: Screws  
 Material: Zinc  
 Quantity: 100 pcs/box

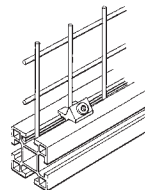

### Shockproof panelling



Plastic panels  
 name: JSM Y\_  
 Other materials can be supplied on request.

### Plastic panel name: JSM Y\_

Article no.	Name	Material	Dimensions	Type
2TLA040039R1000	JSM YPC5A1	Polycarbonate, uncoloured	5 mm	2020 x 864
2TLA040039R1100	JSM YPC5A2	Polycarbonate, uncoloured	5 mm	2020 x 1174
2TLA040039R1200	JSM YPC5A9	Polycarbonate, uncoloured	5 mm	Cut to size
2TLA040039R2400	JSM YPC3AC9	Polycarbonate, dark tint, weld-protected	3 mm	Cut to size
2TLA040039R2500	JSM YPC3AC1	Polycarbonate, dark tint, weld-protected	3 mm	2050x3000
2TLA042150R0600	JSM YG6A9	Laminated glass	6,4 mm	Cut to size



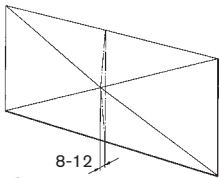

Cross-bent sheet metal panel  
Other materials are available on request.

### Steelplate

Article no.	Name	Material	Thickness	Dimensions
2TLA040039R0700	JSM YGP1A9	Galvanised sheet metal, x-cracked	1 mm	Cut to size
2TLA040039R0900	JSM YGP2A9	Galvanised sheet metal, x-cracked	1,5 mm	Cut to size

Painted sheet metal can be supplied on request.

### Panel fixings

Designation: JSM PL1 (for 5 mm panels)  
JSM PL2 (for 4 mm panels)

Material:  
JSM PL1: PVC, black  
JSM PL2: PVC, black

Quantity: 50 pcs/package

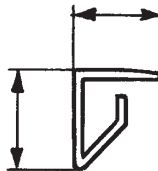

Article no.	Name	Length
2TLA040038R0100	JSM PL1A	842 mm
2TLA040038R0200	JSM PL1B	1152 mm
2TLA040038R0300	JSM PL1C	2000 mm
2TLA040038R0400	JSM PL1D	732 mm
2TLA040038R0700	JSM PL2A	842 mm
2TLA040038R0800	JSM PL2B	1152 mm
2TLA040038R0900	JSM PL2C	2000 mm
2TLA040038R1000	JSM PL2D	732 mm

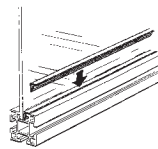

### For metal panel fixings

Designation: JSM G2

Article numbers: 2TLA040038R0600

Material: Cell rubber, self-adhesive

Dimension: 5 x 20 mm

Standard package: 10m/roll

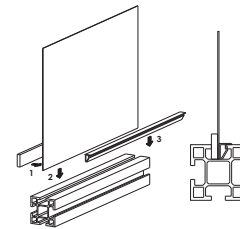
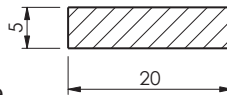

### Sheet securing glass

Designation: JSM G3

Article numbers: 2TLA041930R0600

Material: EPDM

Standard package: 50m/roll

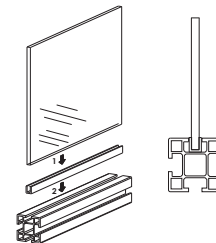
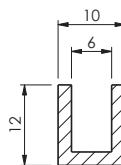

### Panel lockings

Designation: JSM PL3 (for 5 mm panels)

Article numbers: 2TLA040038R1100

Pre-assembled with: Screws

Material: Zinc

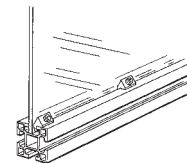

### Soundabsorbing

Article no.	Name	Material	Thickness	Dimensions	Kg/m <sup>2</sup>
2TLA040037R1100	JSM YLA25A9	outside – painted sheet metal inside - galvanised preformed sheet metal core – steel wool	25 mm	Cut to size	13,8
2TLA040039R2600	JSM YLA25A1	check out art.nr 2TLA040037R1100 above	25 mm	1963x1200	13,8
2TLA042150R2300	JSM YLA50A9	check out art.nr 2TLA040037R1100 above	50 mm	Cut to size	21,0

Cut to size – max dimension 2000 x 1200

#### NOTE!

Mounting profile JSM AS1 used for JSM YLA25A\_ and mounting profile  
JSM AS3 used for JSM YLA50A\_

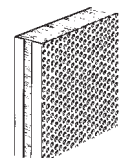

# Safety Roller Door

## Approvals:



## Applications:

Allowing access to risk areas

Protection from ejected particles, e.g chips and welding splash

## Features:

Highest safety level according to EN ISO 13849-1

Prevents unintentional start

Withstands harsh environments

Quick operation

High reliability

Noise absorbing



## Roller door for short safety distances and narrow spaces

Safety Roller Doors make it possible to have a short safety distance to the machine. The noise absorbing roller door is compact and it can therefore be placed in narrow spaces. It is easy and quick to access the machine or gain access for servicing with the Safety Roller Door.

It demands a minimum of maintenance and offers reliable operation. To be able to start the machine/plant the door has to be completely closed. The closed position is monitored by the Eden non-contact sensor from ABB Jokab Safety. As soon as the door begins to open the Eden sends a signal to the machine/plant via the Pluto Safety-PLC from ABB Jokab Safety. The roller door fulfills safety category 4 together with Eden and Pluto.

### Protects against welding splash

The roller door protects against ejected particles, such as chips and welding splash. The roller door fabric is also resistant towards a great number of chemicals, which permits it to be installed in harsh environments.

### Simple assembly

The Safety Roller Door is simple to assemble because it consists of few components and it is supplied partly pre-assembled. It can be integrated into the Quick-Guard fencing system from ABB Jokab Safety as well as in other types of fencing systems. It can also be installed on the machine or other permanent construction.

### Customized roller door

This door design is easy to customize. The largest possible opening width is 4000 mm and the largest possible opening height is 3500 mm. The maximum size of the door fabric is 10 m<sup>2</sup>. If a larger door fabric is desired, contact ABB Jokab Safety. The door is supplied as standard with a light-grey door fabric. Other colours can also be supplied. The roller door can be supplied with a viewing window in full width and at an optional height. The viewing window can also be made in a special material that protects against welding splash.

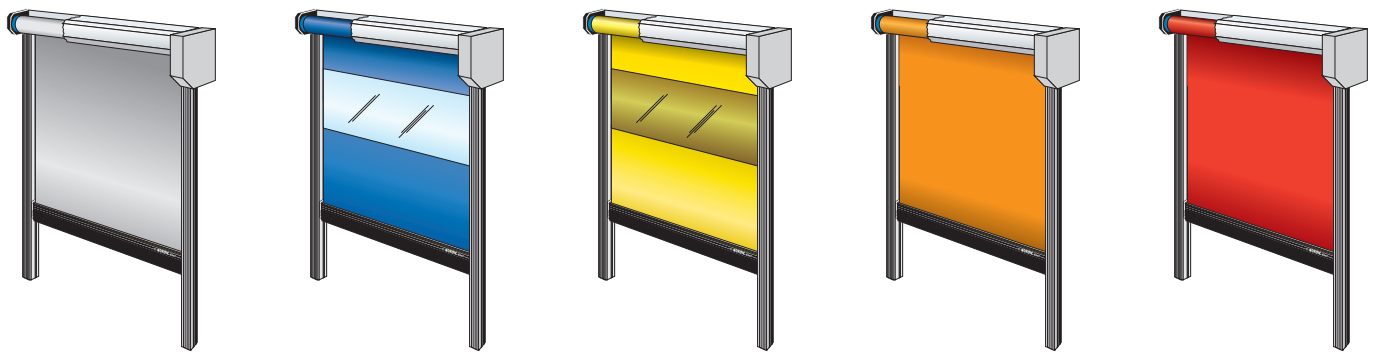

## Function

### Highest protection in accordance with EN ISO 13849-1

The monitoring of the door's position by two Eden sensors together with a Pluto monitoring unit fulfills kat. 4/PL e enligt EN ISO 13849-1. These units are certified by TÜV.

### Functions

The door protects against access to moving parts in the machine/plant. The production process can begin when the door is fully closed. The closed position is monitored by an Eden sensor on both sides of the door. Because the door is monitored by Eden sensors at both sides of the door it is impossible to lift one side of the door and reach into the risk area without the machine/plant stopping. When the door has moved a maximum of 10 mm upwards a stop signal is sent to the protected machine/plant. The Eden sensors are monitored by a Pluto Safety-PLC which has failsafe outputs for stopping the machine/plant in the risk area and to control the door.

The door also protects from particles ejected by the production process, e.g. chips and welding splash. It has a good sound absorbing ability. Because the door operates quickly, at 0.8-1.0 m/s, the operator has a good access to the machine area. The door is equipped with a safety

contact strip in the bottom preventing it from causing personal injury on any person. When the safety contact strip is affected the door is compressed, the door movement reverses to move upwards. The opening and closing of the door can be controlled via the buttons or via the signals from the control system of the machine.

### Prevents an unintentional start

When the door is located in front of the machine/plant, where the operator can enter the area with his entire body, safe interlocking of the door's downward movement is needed. This is to prevent the machine from being started from the outside when somebody is inside the roller door.

One way to solve this is to use a horizontal light curtain which covers the area which the operator can occupy within the risk area. Another solution is to place double light beams in the opening, combined with a reset facility. Yet another solution is to use time-reset. A time-reset button is placed inside the risk area and a button is placed outside the risk area. First, the button in the risk area should be pressed and thereafter (within a certain amount of time, e.g. 5 seconds) the button outside should be pressed. After this the door can be manoeuvred downwards.

## Safety distances & standards

### Minimum safety distance

For the roller door to be able to provide good protection it has to be installed a sufficient distance away from moving machine parts.

### Useful standards

EN ISO 13857 Safety of machinery - Safety distances to prevent hazard zones being reached by upper and lower limbs.

EN ISO 13855 Safety of machinery – Positioning of safeguards with respect to the approach speeds of parts of the human body.

**Note.** The roller door has good protection against welding splash and smaller ejected particles from the the production area. The roller door is not intended to act as collision protection. The installer of the roller door has the responsibility of ensuring that sufficient safety distance against moving machine parts is provided.

## Technical data – Safety Roller Door

<b>Manufacturer</b>	ABB AB/Jokab Safety, Sweden
<b>Colour</b>	Frame - aluminium, door cloth - grey Other colours available on request.
<b>Ordering data</b>	Safety Roller door + viewing window. Viewing window with weld splash protection. Daylight height & Daylight width.
<b>Maximum size, door cloth</b>	10 m <sup>2</sup> If a larger size is needed, contact ABB Jokab Safety AB.
<b>Maximum width</b>	4000 mm
<b>Maximum height</b>	3500 mm
<b>Driving unit</b>	Three-phase motor 200-415 VAC 50-60 Hz
<b>Speed, roller door</b>	0.8 – 1.0 m/s up/down
<b>Max. number of cycles/minute</b>	3 (during continuous operation 24 hours a day)
<b>Door fabric material</b>	Multi-layer polyester fabric cloth with PVC, 2 mm thick or transparent PVC. The viewing window can also be supplied with protection against welding flash light. (Removes 99% of the UV-transmission from the welding process)
<b>Door fabric colour</b>	Grey (RAL 7038), can be supplied with recessed window (only in full width). Other colours are available.
<b>Material frames</b>	Aluminum extrusion
<b>Material upper bracket</b>	4 mm steel painted black
<b>Sound absorption</b>	approx. 10 dB
<b>Ambient temperature</b>	0°C to +55° When operating in temperatures below -5°C, the oil in the gear-box should be replaced with an oil suitable to withstand cold temperatures.
<b>Safety level</b>	Category 4/PL e, in accordance with EN ISO 13849-1
<b>Durability towards chemicals</b>	Ammoniac, sodium hydrate, phosphoric acid, tartaric acid, oxalic acid, hydrochloric acid, citric acid, acetic acid, oil, detergent, calcium chloride (contact ABB Jokab Safety for more specifications)
<b>Control monitoring unit for roller door</b>	ABB Jokab Safety's Safety-PLC, Pluto
<b>Outputs</b>	4 safe outputs for connection to machine/plant.
<b>Monitoring of position of the roller door</b>	2 Eden sensors one on each side of the door.
<b>Contact strip</b>	Mounted on the bottom frame of the door fabric. The door motion is reversed if the contact strip is compressed.

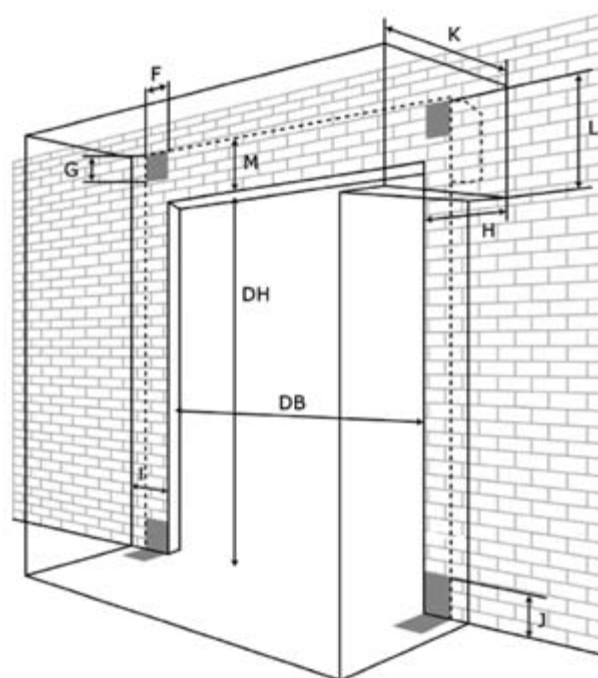
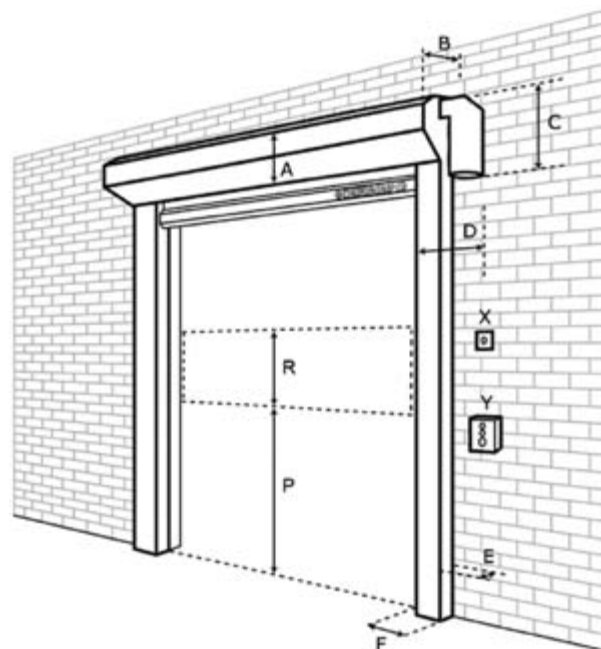

A	260
B	270
C	400
D	200
E	120
F	80
P	Optional
R	Optional

DB	
DH	
F	80
G	250
H	320
I	150
J	100
K	500
L	500
M	450

<b>Contents</b>	<b>Page</b>
<i>Declaration of conformity - Safety relays</i> _____	<b>14:2</b>
<i>Declaration of conformity - JSBR4</i> _____	<b>14:3</b>
<i>Declaration of conformity - Vital 1</i> _____	<b>14:4</b>
<i>Declaration of conformity - Eden, Tina, FMC-Tina and Magne</i> _____	<b>14:5</b>
<i>Declaration of conformity - Smile, INCA1, Stop Line and JSNY10</i> _____	<b>14:6</b>
<i>Declaration of conformity - Knox</i> _____	<b>14:7</b>
<i>Declaration of conformity - Pluto</i> _____	<b>14:8</b>

Descriptions and examples in this book show how the products work and can be used. This does not mean that they can meet the requirements for all types of machines and processes. The purchaser/user is responsible for ensuring that the product is installed and used in accordance with the applicable regulations and standards. We reserve the right to make changes in products and product sheets without previous notice. For the latest updates, refer to [www.jokabsafety.com](http://www.jokabsafety.com). 2011.

## Declaration of conformity - Safety relays

Other language versions may be obtained on request.



### EC Declaration of conformity

(according to 2006/42/EC, Annex 2A)

We ABB AB  
JOKAB Safety  
Varlabergsvägen 11  
SE-434 39 Kungsbacka  
Sweden

declare that the safety components of ABB AB make with type designations and safety functions as listed below, is in conformity with the Directives

2006/42/EC  
2006/95/EC  
2004/108/EC

Person authorised to compile  
the technical file

Lars-Magnus Felth  
ABB AB  
JOKAB Safety  
Varlabergsvägen 11  
SE-434 39 Kungsbacka  
Sweden

#### Product

#### EC type-examination certificate

#### Serialnumber

##### **Safety relay for general use**

JSBT4	44 205 09 372091-002	[000 – 000 ... 999-999]
BT50(T), BT51(T)	44 205 09 372091-003	[000 – 000 ... 999-999]
JSBT5(T)	44 205 09 372091-006	[000 – 000 ... 999-999]
JSBRT11	44 205 09 372091-010	[000 – 000 ... 999-999]
RT9	44 205 09 372091-011	[000 – 000 ... 999-999]
RT6	44 205 09 372091-012	[000 – 000 ... 999-999]
RT7	44 205 09 372091-013	[000 – 000 ... 999-999]
JSBR3	44 205 09 372091-014	[000 – 000 ... 999-999]
JSBT3	44 205 09 372091-015	[000 – 000 ... 999-999]

##### **Expansion relays**

E1T	44 205 09 372091-005	[000 – 000 ... 999-999]
JSR1T	44 205 09 372091-007	[000 – 000 ... 999-999]
JSR2A	44 205 09 372091-008	[000 – 000 ... 999-999]
JSR3T	44 205 09 372091-009	[000 – 000 ... 999-999]

##### **Safety timer-relay**

JSHT1A/B, JSHT2A/B/C	44 205 09 372091-004	[000 – 000 ... 999-999]
----------------------	----------------------	-------------------------

EC type-examination

TÜV NORD CERT GmbH  
Langemarckstrasse 20,  
45141 Essen  
Germany  
Notified body No. 0044

Used harmonized standards

EN ISO 12100-1:2003+A1:2009, EN ISO 12100-2:2003+A1:2009,  
EN 954-1:1996/EN ISO 13849-1:2008, EN 62061:2005, EN 60204-1:2006+A1:2009,  
EN 60664-1:2007, EN 61000-6-1:2007, EN 61000-6-3:2007,  
EN 60947-5-1:2003+A1:2009

Mats Linger  
PRU Manager  
Kungsbacka 2010-11-26

www.abb.com  
www.jokabsafety.com

Original



# Declaration of conformity - JSBR4

Other language versions may be obtained on request.



## EC Declaration of conformity

(according to 2006/42/EC, Annex 2A)

We ABB AB  
JOKAB Safety  
Varlabergsvägen 11  
SE-434 39 Kungsbacka  
Sweden

declare that the safety components of ABB AB make with type designations and safety functions as listed below, are in conformity with the Directives

2006/42/EC  
2006/95/EC  
2004/108/EC

Person authorised to compile  
the technical file

Lars-Magnus Felth  
ABB AB  
JOKAB Safety  
Varlabergsvägen 11  
SE-434 39 Kungsbacka  
Sweden

### Product

Safety relay for two-hand  
applications and other safety  
devices

JSBR4

### EC type-examination certificate

44 205 09 372091-001

### Serialnumber

[000 – 000 ... 999-999]

EC Type-Examination

TÜV NORD CERT GmbH  
Langemarckstrasse 20,  
45141 Essen  
Germany

Notified body No. 0044

Used harmonized standards

EN ISO 12100-1:2003+A1:2009, EN ISO 12100-2:2003+A1:2009,  
EN 574:1996+A1:2008 Type IIIc, EN 954-1:1996/EN ISO 13849-1:2008,  
EN 62061:2005, EN 60204-1:2006+A1:2009, EN 60664-1:2007, EN 61000-6-1:2007,  
EN 61000-6-3:2007, EN 60947-5-1:2003+A1:2009

Mats Linger  
PRU Manager  
Kungsbacka 2010-11-26

[www.abb.com](http://www.abb.com)  
[www.jokabsafety.com](http://www.jokabsafety.com)

Original

## Declaration of conformity- Vital 1

Other language versions may be obtained on request.



### EC Declaration of conformity

(according to 2006/42/EC, Annex2A)

We ABB AB  
JOKAB Safety  
Varlabergsvägen 11  
SE-434 39 Kungsbacka  
Sweden

declare that the safety components of ABB make with type designations and safety functions as listed below, is in conformity with the Directives

2006/42/EC  
2006/95/EC  
2004/108/EC

Person authorised to compile the technical file

Lars-Magnus Felth  
ABB AB  
JOKAB Safety  
Varlabergsvägen 11  
SE-434 39 Kungsbacka  
Sweden

<u>Product</u>	<u>EC type-examination certificate</u>	<u>Serialnumber</u>
Safety module Vital1	44 205 09 372092-001	[000 – 000 ... 999-999]

EC type-examination

TÜV NORD CERT GmbH  
Langemarckstrasse 20  
45141 Essen  
Germany

Notified body No. 0044

Used harmonized standards

EN ISO 12100-1:2003+A1:2009, EN ISO 12100-2:2003+A1:2009,  
EN 954-1:1996/EN ISO 13849-1:2008, EN 62061:2005,  
EN 60204-1:2006+A1:2009, IEC 60664-1:2007, EN 61000-6-2:2005,  
EN 61000-6-4:2007

Mats Linger  
PRU Manager  
Kungsbacka 2010-11-26

---

[www.abb.com](http://www.abb.com)  
[www.jokabsafety.com](http://www.jokabsafety.com)

Original

**Declaration of conformity - Eden, Tina, FMC-Tina and Magne**  
Other language versions may be obtained on request.



**EC Declaration of conformity**

(according to 2006/42/EC, Annex 2A)

We ABB AB declare that the safety components of ABB AB make with type designations and safety functions as listed below, is in conformity with the Directives  
JOKAB SAFETY 2006/42/EC  
Varlabergsvägen 11 2006/95/EC  
SE-434 39 Kungsbacka 2004/108/EC  
Sweden

Person authorised to compile the technical file  
Lars-Magnus Felth  
ABB AB  
JOKAB SAFETY  
Varlabergsvägen 11  
SE-434 39 Kungsbacka  
Sweden

<u>Product</u>	<u>Certificate</u>	<u>Serialnumber</u>
Non-contact safety sensor Eden (Adam , Eva) E/C/EC	44 207 10 372092-001	[000 – 000 ... 999-999]
Adapter unit Tina 1-8, Tina 10-12	44 207 10 372092-001	[000 – 000 ... 999-999]
Muting unit FMC-Tina	44 207 10 372092-001	[000 – 000 ... 999-999]
Non-contact safety sensor including locking function Magne 2A, 2B, 2AX, 2BX	44 207 10 372092-001	[000 – 000 ... 999-999]

Notified body  
TÜV NORD CERT GmbH  
Langemarckstrasse 20  
45141 Essen  
Germany  
Notified body No. 0044

Used harmonized standards  
EN ISO 12100-1:2003+A1:2009, EN ISO 12100-2:2003+A1:2009,  
EN 954-1:1996/EN ISO 13849-1:2008, EN 62061:2005,  
EN 60204-1:2006+A1:2009, EN 60664-1:2007, EN 61000-6-2:2005,  
EN 61000-6-4:2007, EN 60947-5-1:2004, EN 1088+A2:2008

Mats Linger  
PRU Manager  
Kungsbacka 2011-03-02

www.abb.com  
www.jokabsafety.com

Original

# Declaration of conformity - Smile, INCA1, Stop Line and JSNY10

Other language versions may be obtained on request.



## EC Declaration of conformity

(according to 2006/42/EC, Annex2A)

We	ABB AB JOKAB SAFETY Varlabergsgatan 11 SE-434 39 Kungsbacka Sweden	declare that the safety components of ABB AB make with type designations and safety functions as listed below, is in conformity with the Directives
		2006/42/EC 2006/95/EC
Person authorised to compile the technical file	Lars-Magnus Felth ABB AB JOKAB Safety Varlabergsgatan 11 SE-434 39 Kungsbacka Sweden	
<b>Product</b>	<b>Certificate</b>	
Emergency stop device Smile, versions 10EA, 10EAK, 11EA, 12EA, 11EAR	11-SKM-CM-0103	
Emergency stop device INCA 1	11-SKM-CM-0103	
Emergency stop wire Stop Line		
Emergency stop wire JSNY10		
Notified Body	Inspecta Sweden AB Box 30100 SE-104 25 Stockholm Sweden Notified Body No. 0409	
Used harmonized standards	EN ISO 12100:2010, EN 954-1:1996, EN ISO 13849-1:2008/AC:2009, EN 60204-1:2007+A1, EN ISO 13850:2008	

Mats Linger  
PRU Manager  
Kungsbacka 2011-03-04

---

[www.abb.com](http://www.abb.com)  
[www.jokabsafety.com](http://www.jokabsafety.com)

Original

## Declaration of conformity- Knox

Other language versions may be obtained on request.



### EC Declaration of conformity

(according to 2006/42/EC, Annex 2A)

We ABB AB  
JOKAB Safety  
Varlabergsgatan 11  
SE-434 39 Kungsbacka  
Sweden

declare that the safety components of ABB AB manufacture with type designations and safety functions as listed below, is in conformity with the Directives  
2006/42/EC  
2006/95/EC  
2004/108/EC

Person authorised to compile the technical file

Lars-Magnus Felth  
ABB AB  
JOKAB Safety  
Varlabergsgatan 11  
SE-434 39 Kungsbacka  
Sweden

#### Product

Non-contact safety sensor including locking function  
Knox

#### Certificate

815 933

Notified body

INTERTEK SEMKO AB  
Box 1103  
SE-164 22 KISTA  
Sweden  
Notified body no 0413

Used harmonized standards

EN ISO 12100-1:2003+A1:2009, EN ISO 12100-2:2003+A1:2009,  
EN 954-1:1996/EN ISO 13849-1:2008, EN 1088+A2:2008,  
EN 60204-1:2006+A1:2009, EN 61000-6-2:2005, EN 61000-6-4:2007

Mats Linger  
PRU Manager  
Kungsbacka 2010-11-26

---

[www.abb.com](http://www.abb.com)  
[www.jokabsafety.com](http://www.jokabsafety.com)

Original

## Declaration of conformity - Pluto

Other language versions may be obtained on request.



### EC declaration of conformity

(according to 2006/42/EC, Annex 2A)

We ABB AB declare that the safety components of ABB manufacture,  
JOKAB Safety with type designations and safety functions as listed below,  
Varlabergsvägen 11 are in conformity with the Directives  
SE-434 39 Kungsbacka 2006/42/EC  
Sweden 2004/108/EC  
2006/95/EC

Person authorised to compile the technical file Göran Svensson  
ABB AB  
Jokab Safety  
Kanalvägen 17  
SE-183 30 Täby  
Sweden

Programmable electronic safety system (Safety PLC system) Pluto version  
A20, B20, B16, S19, S20, B46, S46, AS-i, B42 AS-i

Used harmonized standards	EN ISO 13849-1:2006/EN 954-1	(Directive 2006/42/EC)
	EN ISO 13849-1:2008	(Directive 2006/42/EC)
	EN 62061	(Directive 2006/42/EC)
	EN 61496-1	(Directive 2006/42/EC)
	EN 574	(Directive 2006/42/EC)
	EN 692	(Directive 2006/42/EC)
	EN 60204-1	(Directive 2006/95/EC)
	EN 50178	(Directive 2006/95/EC)
	EN 61000-6-2	(Directive 2004/108/EC)
EN 61000-6-4	(Directive 2004/108/EC)	
EN 61000-4-1...6	(Directive 2004/108/EC)	

Other used standards and documents IEC/EN 61508  
DIN V VDE 0801:1990 with amendment A1:1994

EC Type-Examination TÜV-Rheinland  
Am Grauen Stein  
D-51105 Köln  
Germany

Notified body No. 0035

Certificate no 01/205/5066/10

Mats Linger  
PRU Manager  
Kungsbacka 2011-01-01

---

[www.abb.com](http://www.abb.com)  
[www.jokabsafety.com](http://www.jokabsafety.com)

Original













# Contact us

**ABB AB**

**Jokab Safety**

Tel. +46 300-67 59 00

[www.abb.com/lowvoltage](http://www.abb.com/lowvoltage)