

Industrial Controls

SIRIUS 3R_1* in sizes S00/S0 to S12

Catalog Add-On IC 10 AO · 2012



SIRIUS

Answers for industry.

SIEMENS

Related catalogs

Industrial Controls SIRIUS

IC 10



E86060-K1010-A101-A2-7600

Industrial Controls SIRIUS

IC 01



E86060-D1001-A101-A2-7600

Safety Integrated Safety Technology for Factory Automation

SI 10



E86060-K7010-A101-A2-7600

Industrial Communication SIMATIC NET

IK PI



E86060-K6710-A101-B7-7600

SIMATIC

Products for
Totally Integrated Automation
and Micro Automation

ST 70



E86060-K4670-A101-B3-7600

Catalog CA 01

Products for Automation and Drives

CA 01



DVD: E86060-D4001-A510-D1-7600

Industry Mall

Information and Ordering Platform
in the Internet:



www.siemens.com/industrymall

Contents

Industrial communication • Controls • Protection equipment • Load feeders and motor starters • Monitoring and control devices • Safety control devices • Detecting devices • Commanding and signaling devices • Parameterization, configuration and visualization • Transformers and power supplies • Heating controls • Components for charging electric vehicles

Technical product data for CAx applications (DVD) and catalogs in PDF format (CD) :
IC 10, IC 10 AO, IK PI, ITC, D 81.1, LV 10.1, SI 10, ST 70

Detecting • Evaluation / Communication • Reacting

PROFINET / Industrial Ethernet • PROFIBUS • SIMATIC ET 200 Distributed I/O • SIMATIC Ident Identification Systems • AS-Interface • IO-Link • Industrial Wireless Communication • Industrial Remote Communication • ECOFAST

LOGO! logic module • SIMATIC S7-200 • SIMATIC S7-1200 • SIMATIC S7-300 • SIMATIC S7-400 • Embedded controller • SIMATIC PC-based controller • SIMATIC ET 200 distributed I/O • SIMATIC control systems • SIMATIC industrial software • SIMATIC programming devices • Overview • Supplementary Components

All products of automation, drives and installation technology, including those in the catalogs listed above.

All products of automation, drives and installation technology, including those in the catalogs listed above.

Registered trademarks

All product designations may be registered trademarks or product names of Siemens AG or other supplying companies. Third parties using these trademarks or product names for their own purposes may infringe upon the rights of the trademark owners.

Further information about industrial controls:
www.siemens.de/sirius

Technical Assistance

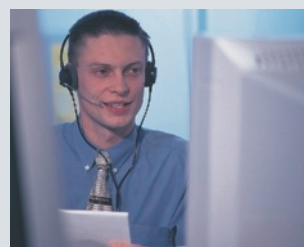

Expert technical assistance for
Industrial controls:

Tel.: +49 (9 11) 8 95-59 00

Fax: +49 (9 11) 8 95-59 07

E-Mail: technical-assistance@siemens.com

SIRIUS

Industrial Controls

SIRIUS 3R_1* in sizes
S00/S0 to S12

Catalog Add-On IC 10 AO · 2012



IQNet
THE INTERNATIONAL CERTIFICATION NETWORK

The products and systems listed in this catalog are manufactured/distributed using a certified quality management system which complies with EN ISO 9001 (for the Certificate Register Nos. see the Appendix to IC 10 · 2012). The certificate is recognized in all IQNet countries.

Supersedes:
Catalog Add-On LV 1 AO · 2011

For the latest updates of this catalog, please visit our Industry Mall:
www.siemens.com/industrymall

The products contained in this catalog can also be found in the interactive catalog CA 01.
Order No.:
E86060-D4001-A510-D1-7600 (DVD)

Contact your local Siemens sales office for further information

© Siemens AG 2011

Introduction	1
Industrial Communication	2
Controls – Contactors and Contactor Assemblies – for Switching Motors	3
Controls – Contactors and Contactor Assemblies – Special Applications	4
Controls – Contactors and Contactor Assemblies – Contactor Relays and Relays	5
Controls – Soft Starters and Solid-State Switching Devices	6
Protection Equipment	7
Load Feeders and Motor Starters for Operation in the Control Cabinet	8
Motor Starters for Operation in the Field, High Degree of Protection	9
Monitoring and Control Devices	10
Safety Equipment	11
Position and Safety Switches	12
Commanding and Signaling Devices	13
Parameterization, Configuration and Visualization for SIRIUS	14
Products for Specific Requirements	15
Appendix	16

Notes

Price group changes



Code conversion table

Starting 01/10/2011 there will be new price groups for the SIRIUS industrial control products.

To help you with the changeover, the code conversion table below shows the former price groups alongside those which come into force on 01/10/2011.

Previous price group	Price group in force from 01/10/2011	Product	Chapter
101	41A	Contactors relays	5
	41B	Contactors and contactor assemblies	3 and 4
	41C	Solid-state contactors	6
	41D	Load Feeders	8
	41E	Motor Starter Protectors	7
	41F	Thermal Overload Relays	7
	41G	Solid-State Overload Relays	7
	41H	Relays	4, 5 and 10
102	41J	Pushbuttons and indicator lights	13
	41K	Position and Safety Switches	12
	41L	Safety relays	11
104	4M1	Transformers and power supplies	15
121	42A	Communication-capable safety products	12 and 13
	42C	AS-Interface /IO-Link	2
	42D	Motor starters	8 and 9
	42E	Motor control units (MCU)	9
	42F	Compact feeders	8
131	42B	Modular safety system	11
	42G	Standard soft starters	6
	42H	High-Feature soft starters	6
	42J	SIMOCODE	10
191	401	Technical documentation	2 to 15

Industry Mall

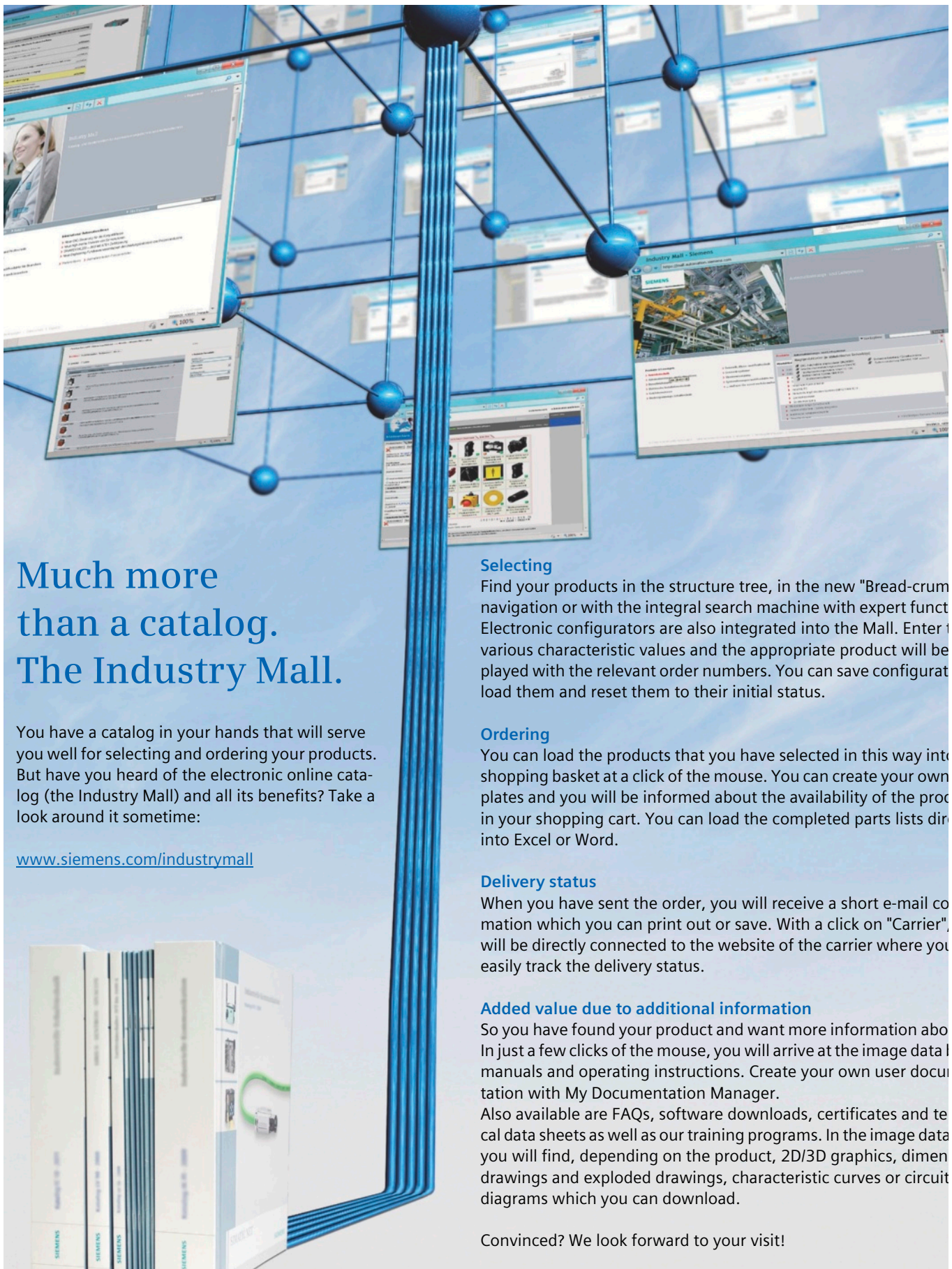

Much more than a catalog. The Industry Mall.

You have a catalog in your hands that will serve you well for selecting and ordering your products. But have you heard of the electronic online catalog (the Industry Mall) and all its benefits? Take a look around it sometime:

www.siemens.com/industrymall

Selecting

Find your products in the structure tree, in the new "Bread-crum" navigation or with the integral search machine with expert function. Electronic configurators are also integrated into the Mall. Enter various characteristic values and the appropriate product will be played with the relevant order numbers. You can save configurations, load them and reset them to their initial status.

Ordering

You can load the products that you have selected in this way into shopping basket at a click of the mouse. You can create your own plates and you will be informed about the availability of the product in your shopping cart. You can load the completed parts lists directly into Excel or Word.

Delivery status

When you have sent the order, you will receive a short e-mail communication which you can print out or save. With a click on "Carrier", you will be directly connected to the website of the carrier where you can easily track the delivery status.

Added value due to additional information

So you have found your product and want more information about it. In just a few clicks of the mouse, you will arrive at the image data, manuals and operating instructions. Create your own user documentation with My Documentation Manager.

Also available are FAQs, software downloads, certificates and technical data sheets as well as our training programs. In the image data you will find, depending on the product, 2D/3D graphics, dimension drawings and exploded drawings, characteristic curves or circuit diagrams which you can download.

Convinced? We look forward to your visit!

Things you should know about Catalog Add-On IC 10 AO

Catalog Add-On IC 10 AO contains all selection and order-relevant data.

More information can be found on the Internet: see the Internet addresses in the opening information, [Page 8](#).

Delivery time class (DT)

▶ Preferred type	Preferred types are available immediately from stock, i. e. are dispatched within 24 hours.	The delivery times apply up to the ramp at Siemens AG (products ready for dispatch). The transport times depend on the destination and type of shipping. The standard transport time for Germany is 1 day. The delivery time classes specified here represent the state of 10/2011. They are permanently optimized. For more up-to-the-minute information, please visit our site at www.siemens.com/sirius/mall .
A 1 or 2 working days	Normal quantities of the products are usually delivered within the specified time following receipt of your order at our branch.	
B 3 to 5 working days		
C 6 to 15 working days		
D 16 to 30 working days	In exceptional cases, the actual delivery time may differ from that specified.	
X On request		

Price units (PU)

The price unit defines the number of units, sets or meters to which the specified price and weight apply.

Packaging sizes (PS)

The packaging size defines the number, e. g. of units, sets or meters, for outer packaging.
Only the quantity defined by the packaging size or a multiple thereof can be ordered!

For multi-unit packing and reusable packaging see [Appendix IC 10](#).

Price groups (PG)

Each product is assigned to a price group.

Dimensions











All dimensions in mm.

Symbols

In the Catalog Add-on IC 10 AO you will find the symbols and their explanations listed alongside.

They are use in conjunction with an orange background to mark and highlight special selection criteria (e. g. connections, types of coordination, etc.).

Connections

Combicon connection	
Insulation piercing method	
Fast Connect	
Spring-type terminals	
Flat connectors	
Solder pin connections	
Ring terminal lug connections	
Screw terminals	
Types of coordination	
Type of coordination "1"	
Type of coordination "2"	

The secrets of UL.

Our industrial control products are designed not only for the IEC market. Numerous devices have both UL and IEC approval. This makes it easier for manufacturers of switchgear and controlgear assemblies to enter the North American market.

Exports to North America require special approvals which differ from the IEC directives. On the IEC market, directives define only the essential functions of a system. The technical details are not listed. By contrast, directives on the American market go into the details of how to carry out the installation work etc.

For OEMs and machine manufacturers it is important to know the main differences between the two technical worlds and to work together respectively with manufacturers and suppliers who have the right products and know-how.

Siemens is a strong partner in this case. Our know-how extends from the production of UL-approved devices to the wiring of control cabinets according to UL directives.

These UL requirements are already taken into account when designing our industrial control devices. They are developed not only for the IEC market but also for the UL market.

We have been working with UL (Underwriters Laboratories Inc.®), the leading technical certification company in the USA, since 1969. We are also glad to share our knowledge with you in the form of training courses.

With our UL-certified products for industrial controls you are on the safe side and can build control cabinets according to UL standard easily and quickly.

In the Catalog IC 10 you will find for example the following UL-certified products:

- Controls, from motor-protective circuit breakers and starters to contactors and overload relays
- Circuit breakers for plant and transformer protection
- Detecting devices and command devices
- Transformers and power supplies

ATEX explosion protection

In many industries the production, processing, transport and storage of combustible substances are accompanied by escaping gases, vapor or spray which find their way into the environment. Other processes result in combustible dust. Together with the oxygen in the air, the result can be an explosive atmosphere which will explode if ignited.

Serious injury to persons and damage to property can result particularly in the chemical and petrochemical industry, mineral oil and natural gas production, mining, mills (e. g. grain, solid materials) and many other sectors.

To guarantee the maximum possible safety in these areas, the legislators of most countries have drawn up requirements in the form of laws, regulations and standards. In the course of globalization, great progress has been made with regard to uniform directives for explosion protection.

With Directive 94/9/EC, the European Union laid the foundations for complete harmonization by requiring that all new devices as from 1st July 2003 have to be approved in accordance with this directive.



Take a look at our range of products and convince yourself. Or simply click on

www.siemens.com/ul-europa

Here you will find information on for example UL standards, UL classification and a number of technical particularities of UL.

Under "UL Overview/Standards and Approvals" we provide a summary of the available products and product groups. A table lists the UL standards to which the products conform and contains links to the corresponding UL reports.

Under "Portfolio" we round off with a list of the most relevant products for industrial control (including links to the respective Internet product pages).

Simply click on the navigation bar and go on a UL discovery tour!

In this catalog, special attention is drawn to devices which comply with the ATEX Directive. However, it does not replace intensive study of the relevant fundamentals and directives when planning and installing electrical systems. You can find more information about ATEX at

www.siemens.com/sirius/atex.



Internet addresses

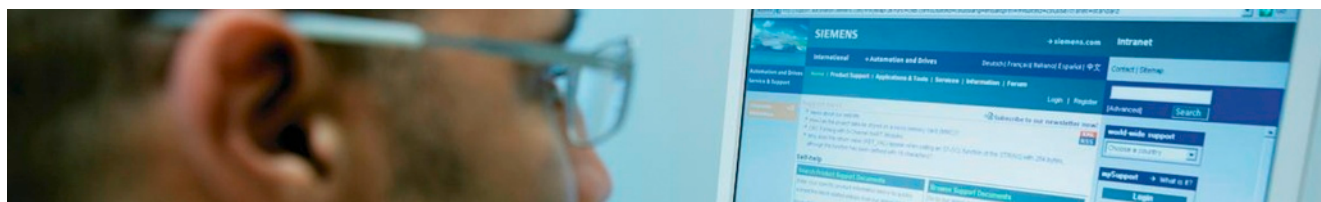

Contact partners:	
Electrical wholesalers / distributors	www.siemens.com/automation/distributorensuche
Industry Automation and Drive Technologies	www.siemens.com/automation/partner
Siemens Solution Partner Automation	www.siemens.com/automation/partnerfinder
Technical assistance	www.siemens.com/sirius/technical-assistance
ATEX explosion protection	www.siemens.com/sirius/atex
Brochures, customer magazines, trial versions of software, special offer packages	www.siemens.com/sirius/infocenter
CAX online generator	www.siemens.com/cax
Manuals	www.siemens.com/sirius/manuals
Energy efficiency	www.siemens.de/sirius/energiesparen
Industry Mall	www.siemens.com/sirius/mall
Interactive catalog CA 01	www.siemens.com/automation/ca01
Catalogs	www.siemens.com/sirius/catalogs
Configurators	www.siemens.com/sirius/configurators
Newsletter	www.siemens.com/sirius/newsletter
Product pictures	www.siemens.com/sirius/images
Safety Integrated	www.siemens.com/safety-integrated
SIPLUS products for specific requirements	www.siemens.com/siplus www.siemens.com/siplus-extreme
SIRIUS industrial controls	www.siemens.com/sirius
Service and support:	
mySupport / support request	www.siemens.com/sirius/technical-assistance
Product support	www.siemens.com/sirius/support
SIRIUS eAssistance	www.siemens.com/sirius/eAssistance
TIA portal	www.siemens.com/tia-portal
Training	www.siemens.com/sirius/training
UL information	www.siemens.com/ul-europa
Certificates	www.siemens.com/sirius/approvals

Overview

Order No.	Page	Metal sur-charges	Export markings	
			ECCN	AL
3RA				
3RA11 1	8/4 ... 8/11	LCO---	N	N
3RA11 2	8/4 ... 8/11	LCO---	N	N
3RA11 3	8/4, 8/6	LCO---	N	N
3RA12 1	8/12 ... 8/19	LCO---	N	N
3RA12 2	8/12 ... 8/19	LCO---	N	N
3RA13 1	3/60	LCO---	N	N
3RA13 2	3/61	LCO---	N	N
3RA13 3	3/62	LCO---	N	N
3RA13 4	3/63	LCO---	N	N
3RA14 1	3/69	LCO---	EAR99	N
3RA14 2	3/70	LCO---	N	N
3RA14 3	3/71 ... 72	LCO---	N	N
3RA14 4	3/73	LCO---	N	N
3RA19 0	8/23	--	N	N
3RA19 11-1	7/28, 8/22	L-P---	N	N
3RA19 11-2	7/28 ... 29, 8/22, 8/24	L-P---	N	N
3RA19 12	3/66	--	N	N
3RA19 13	3/65 ... 66, 3/74, 8/22, 8/25	L-P---	N	N
3RA19 21	7/28, 8/22	L-P---	N	N
3RA19 22	3/66, 7/29, 8/23 ... 24	--	N	N
3RA19 23	3/64 ... 66, 3/74, 8/22 ... 23, 8/25	L-P---	N	N
3RA19 24	3/64, 8/23	--	N	N
3RA19 31	7/28, 8/22	L-P---	N	N
3RA19 32	3/66, 3/74, 8/23	--	N	N
3RA19 33	3/65 ... 66, 3/74, 8/22 ... 23, 8/25	L-P---	N	N
3RA19 41	7/28, 8/22	L-P---	N	N
3RA19 42	3/66, 3/74, 8/23	--	N	N
3RA19 43	3/65 ... 66, 3/74, 8/22 ... 23	L-P---	N	N
3RA19 52-2A	3/64	--	N	N
3RA19 52-2E	3/74	--	N	N
3RA19 52-2F	3/74	--	N	N
3RA19 53-2A	3/65	L-P---	N	N
3RA19 53-2B	3/74	L-P---	N	N
3RA19 53-2M	3/65	L-P---	N	N
3RA19 53-2N	3/74	L-P---	N	N
3RA19 53-3	3/66	L-P---	N	N
3RA19 54	3/64	--	N	N
3RA19 62-2A	3/64	--	N	N
3RA19 62-2E	3/74	--	N	N
3RA19 62-2F	3/74	--	N	N
3RA19 63-2A	3/65	L-P---	N	N
3RA19 63-2B	3/74	L-P---	N	N
3RA19 72-2A	3/64	--	N	N
3RA19 72-2E	3/74	--	N	N
3RA19 72-2F	3/74	--	N	N
3RA19 73-2A	3/65	L-P---	N	N
3RA19 73-2B	3/74	L-P---	N	N
3RA2	3/49, 5/9, 7/29, 7/47, 7/54, 7/62	--	N	N

Order No.	Page	Metal sur-charges	Export markings	
			ECCN	AL
3RB				
3RB1	7/27, 7/61, 8/24	--	N	N
3RB20 16-1	7/50	L-O---	EAR99	N
3RB20 16-2N	7/51	L-O---	EAR99	N
3RB20 16-2P	7/51	L-O---	EAR99	N
3RB20 16-2RB	7/51	L-O---	N	N
3RB20 16-2RD	7/51	L-O---	EAR99	N
3RB20 16-2S	7/51	L-O---	EAR99	N
3RB20 26-1	7/50	L-O---	EAR99	N
3RB20 26-2	7/51	L-O---	EAR99	N
3RB20 36-1	7/50	L-O---	EAR99	N
3RB20 36-2QB	7/51	L-O---	EAR99	N
3RB20 36-2QD	7/51	L-O---	N	N
3RB20 36-2QW	7/51	L-O---	EAR99	N
3RB20 36-2QX	7/51	L-O---	EAR99	N
3RB20 36-2U	7/51	L-O---	EAR99	N
3RB20 46-1EB	7/50	L-O---	N	N
3RB20 46-1ED	7/50	L-O---	EAR99	N
3RB20 46-1EW	7/50	L-O---	EAR99	N
3RB20 46-1EX	7/50	L-O---	EAR99	N
3RB20 46-1U	7/50	L-O---	EAR99	N
3RB20 46-2E	7/51	L-O---	EAR99	N
3RB20 46-2UB	7/51	L-O---	EAR99	N
3RB20 46-2UD	7/51	L-O---	N	N
3RB20 56-1	7/50	L-O---	EAR99	N
3RB20 56-2	7/51	L-O---	EAR99	N
3RB20 66-1GC	7/50	L-O---	EAR99	N
3RB20 66-1GF	7/50	L-O---	N	N
3RB20 66-1MC	7/50	L-O---	EAR99	N
3RB20 66-1MF	7/50	L-O---	N	N
3RB20 66-2	7/51	L-O---	EAR99	N
3RB21 1	7/52	L-O---	EAR99	N
3RB21 23-4N	7/52	L-O---	EAR99	N
3RB21 23-4PB	7/52	L-O---	EAR99	N
3RB21 23-4PD	7/52	L-O---	N	N
3RB21 23-4Q	7/52	L-O---	EAR99	N
3RB21 23-4R	7/52	L-O---	EAR99	N
3RB21 23-4SB	7/52	L-O---	N	N
3RB21 23-4SD	7/52	L-O---	EAR99	N
3RB21 33-4QB	7/52	L-O---	EAR99	N
3RB21 33-4QD	7/52	L-O---	N	N
3RB21 33-4QW	7/52	L-O---	EAR99	N
3RB21 33-4QX	7/52	L-O---	N	N
3RB21 33-4UB	7/52	L-O---	EAR99	N
3RB21 33-4UD	7/52	L-O---	EAR99	N
3RB21 33-4UW	7/52	L-O---	EAR99	N
3RB21 33-4UX	7/52	L-O---	N	N
3RB21 43-4EB	7/52	L-O---	EAR99	N
3RB21 43-4ED	7/52	L-O---	N	N
3RB21 43-4EW	7/52	L-O---	EAR99	N
3RB21 43-4EX	7/52	L-O---	EAR99	N
3RB21 43-4U	7/52	L-O---	EAR99	N

Order No.	Page	Metal sur-charges	Export markings	
			ECCN	AL
3RB21 5	7/52	L-O---	EAR99	N
3RB21 6	7/52	L-O---	EAR99	N
3RB22	7/57	--	N	N
3RB23	7/57	--	N	N
3RB29 0	7/60	L-O---	N	N
3RB29 1	7/53	--	N	N
3RB29 2	7/53	--	N	N
3RB29 5	7/60	L-O---	N	N
3RB29 6	7/60	L-O---	N	N
3RB29 8	7/54, 7/60 ... 61	--	N	N
3RE				
3RE10	9/4	LCO---	N	N
3RE13	9/4	LCO---	N	N
3RE19	9/4	--	N	N
3RH				
3RH11 22-1A	5/5	LDO---	N	N
3RH11 22-1B	5/6	LCP---	N	N
3RH11 22-1H	5/11	LCP---	N	N
3RH11 22-1J	5/12	LCP---	N	N
3RH11 22-1K	5/12	LCP---	N	N
3RH11 22-1M	5/11	LCP---	N	N
3RH11 22-1V	5/12	LCP---	N	N
3RH11 22-1W	5/12	LCP---	N	N
3RH11 22-2A	5/5	LDO---	N	N
3RH11 22-2B	5/6	LCP---	N	N
3RH11 22-2H	5/11	LCP---	N	N
3RH11 22-2J	5/12	LCP---	N	N
3RH11 22-2K	5/12, 5/14	LCP---	N	N
3RH11 22-2M	5/11	LCP---	N	N
3RH11 22-2V	5/12	LCP---	N	N
3RH11 22-2W	5/12	LCP---	N	N
3RH11 31-1A	5/5	LDO---	N	N
3RH11 31-1B	5/6	LCP---	N	N
3RH11 31-1H	5/11	LCP---	N	N
3RH11 31-1J	5/12	LCP---	N	N
3RH11 31-1K	5/12	LCP---	N	N
3RH11 31-1M	5/11	LCP---	N	N
3RH11 31-1V	5/12	LCP---	N	N
3RH11 31-1W	5/12	LCP---	N	N
3RH11 31-2A	5/5	LDO---	N	N
3RH11 31-2B	5/6	LCP---	N	N
3RH11 31-2H	5/11	LCP---	N	N
3RH11 31-2J	5/12	LCP---	N	N
3RH11 31-2K	5/12	LCP---	N	N
3RH11 31-2M	5/11	LCP---	N	N
3RH11 31-2V	5/12	LCP---	N	N
3RH11 31-2W	5/12	LCP---	N	N
3RH11 40-1A	5/5	LDO---	N	N
3RH11 40-1B	5/6	LCP---	N	N
3RH11 40-1H	5/11	LCP---	N	N
3RH11 40-1J	5/12	LCP---	N	N
3RH11 40-1K	5/12	LCP---	N	N
3RH11 40-1M	5/11	LCP---	N	N
3RH11 40-1V	5/12	LCP---	N	N
3RH11 40-1W	5/12	LCP---	N	N
3RH11 40-2A	5/5	LDO---	N	N
3RH11 40-2B	5/6	LCP---	N	N

Order No.	Page	Metal sur-charges	Export markings	
			ECCN	AL
3RH11 40-2H	5/11	LCP---	N	N
3RH11 40-2J	5/12	LCP---	N	N
3RH11 40-2K	5/12	LCP---	N	N
3RH11 40-2M	5/11	LCP---	N	N
3RH11 40-2V	5/12	LCP---	N	N
3RH11 40-2W	5/12	LCP---	N	N
3RH12 44-1A	5/5	LDO---	N	N
3RH12 44-1B	5/6	LCP---	N	N
3RH12 44-2A	5/5	LDO---	N	N
3RH12 44-2B	5/6	LCP---	N	N
3RH12 62-1A	5/5	LDO---	N	N
3RH12 62-1B	5/6	LCP---	N	N
3RH12 62-2A	5/5	LDO---	N	N
3RH12 62-2B	5/6	LCP---	N	N
3RH14 22-1A	5/10	LDO---	N	N
3RH14 22-1B	5/10	LCP---	N	N
3RH14 31-1A	5/10	LDO---	N	N
3RH14 31-1B	5/10	LCP---	N	N
3RH14 40-1A	5/10	LDO---	N	N
3RH14 40-1B	5/10	LCP---	N	N
3RH19 11-1A	3/36	LD----	N	N
3RH19 11-1B	3/37, 8/20	LD----	N	N
3RH19 11-1F	3/36, 8/20	LD----	N	N
3RH19 11-1G	5/7	LD----	N	N
3RH19 11-1H	3/35	LD----	N	N
3RH19 11-1L	3/36	LD----	N	N
3RH19 11-1M	3/37, 8/20	LD----	N	N
3RH19 11-1N	3/40	LD----	N	N
3RH19 11-2F	3/36	LD----	N	N
3RH19 11-2G	5/7	LD----	N	N
3RH19 11-2H	3/35	LD----	N	N
3RH19 11-2N	3/40	LD----	N	N
3RH19 21-1C	3/38, 8/20	LD----	N	N
3RH19 21-1D	3/39	LD----	N	N
3RH19 21-1E	3/39	LD----	N	N
3RH19 21-1F	3/37, 3/40, 8/20	LD----	N	N
3RH19 21-1H	3/35	LD----	N	N
3RH19 21-1J	3/39	LD----	N	N
3RH19 21-1K	3/39	LD----	N	N
3RH19 21-1L	3/38	LD----	N	N
3RH19 21-1M	3/38, 8/20	LD----	N	N
3RH19 21-1X	3/35	LD----	N	N
3RH19 21-2C	3/38	LD----	N	N
3RH19 21-2D	3/39 ... 40	LD----	N	N
3RH19 21-2E	3/39	LD----	N	N
3RH19 21-2F	3/37, 3/40	LD----	N	N
3RH19 21-2H	3/35	LD----	N	N
3RH19 21-2J	3/39 ... 40	LD----	N	N
3RH19 21-2K	3/39	LD----	N	N
3RH19 21-2X	3/35	LD----	N	N
3RH19 24	3/46	LCP---	N	N
3RK, 3RP				
3RK	3/45, 5/9	--	N	N
3RP	7/61	--	N	N
3RT10				
3RT10 15-1A	3/15	LFO---	N	N
3RT10 15-1B	3/19	LDP---	N	N

Order No.	Page	Metal sur-charges	Export markings	
			ECCN	AL
3RT10 15-1H	3/55	LDP---	N	N
3RT10 15-1J	3/56	LDP---	N	N
3RT10 15-1K	3/57	LDP---	N	N
3RT10 15-1M	3/55	LDP---	N	N
3RT10 15-1V	3/56	LDP---	N	N
3RT10 15-1W	3/57	LDP---	N	N
3RT10 15-2A	3/15	LFO---	N	N
3RT10 15-2B	3/19	LDP---	N	N
3RT10 15-2H	3/55	LDP---	N	N
3RT10 15-2J	3/56	LDP---	N	N
3RT10 15-2K	3/57	LDP---	N	N
3RT10 15-2M	3/55	LDP---	N	N
3RT10 15-2V	3/56	LDP---	N	N
3RT10 15-2W	3/57	LDP---	N	N
3RT10 16-1A	3/15	LFO---	N	N
3RT10 16-1B	3/19	LDP---	N	N
3RT10 16-1H	3/55	LDP---	N	N
3RT10 16-1J	3/56	LDP---	N	N
3RT10 16-1K	3/57	LDP---	N	N
3RT10 16-1M	3/55	LDP---	N	N
3RT10 16-1V	3/56	LDP---	N	N
3RT10 16-1W	3/57	LDP---	N	N
3RT10 16-2A	3/15	LFO---	N	N
3RT10 16-2B	3/19	LDP---	N	N
3RT10 16-2H	3/55	LDP---	N	N
3RT10 16-2J	3/56	LDP---	N	N
3RT10 16-2K	3/57	LDP---	N	N
3RT10 16-2M	3/55	LDP---	N	N
3RT10 16-2V	3/56	LDP---	N	N
3RT10 16-2W	3/57	LDP---	N	N
3RT10 17-1A	3/15	LFO---	N	N
3RT10 17-1B	3/19	LDP---	N	N
3RT10 17-1H	3/55	LDP---	N	N
3RT10 17-1J	3/56	LDP---	N	N
3RT10 17-1K	3/57	LDP---	N	N
3RT10 17-1M	3/55	LDP---	N	N
3RT10 17-1V	3/56	LDP---	N	N
3RT10 17-1W	3/57	LDP---	N	N
3RT10 17-2A	3/15	LFO---	N	N
3RT10 17-2B	3/19	LDP---	N	N
3RT10 17-2H	3/55	LDP---	N	N
3RT10 17-2J	3/56	LDP---	N	N
3RT10 17-2K	3/57, 4/14 ... 15	LDP---	N	N
3RT10 17-2M	3/55	LDP---	N	N
3RT10 17-2V	3/56	LDP---	N	N
3RT10 17-2W	3/57	LDP---	N	N
3RT10 23-1A	3/16	LFO---	N	N
3RT10 23-1B	3/20	LDP---	N	N
3RT10 23-3A	3/16	LFO---	N	N
3RT10 23-3B	3/20	LDP---	N	N
3RT10 24-1A	3/16	LFO---	N	N
3RT10 24-1B	3/20	LDP---	N	N
3RT10 24-1K	3/58	LDP---	N	N
3RT10 24-3A	3/16	LFO---	N	N
3RT10 24-3B	3/20	LDP---	N	N
3RT10 24-3K	3/58	LDP---	N	N
3RT10 25-1A	3/16	LFO---	N	N

Order No.	Page	Metal sur-charges	Export markings	
			ECCN	AL
3RT10 25-1B	3/20	LDP---	N	N
3RT10 25-1K	3/58	LDP---	N	N
3RT10 25-1X	4/16	LDP---	EAR99	N
3RT10 25-3A	3/16	LFO---	N	N
3RT10 25-3B	3/20	LDP---	N	N
3RT10 25-3K	3/58, 4/14 ... 15	LDP---	N	N
3RT10 25-3XB	4/16	LDP---	N	N
3RT10 25-3XF	4/16	LDP---	EAR99	N
3RT10 26-1A	3/16	LFO---	N	N
3RT10 26-1B	3/20	LDP---	N	N
3RT10 26-1K	3/58	LDP---	N	N
3RT10 26-1X	4/16	LDP---	EAR99	N
3RT10 26-3A	3/16	LFO---	N	N
3RT10 26-3B	3/20	LDP---	N	N
3RT10 26-3K	3/58, 4/14 ... 15	LDP---	N	N
3RT10 26-3XB	4/16	LDP---	N	N
3RT10 26-3XF	4/16	LDP---	EAR99	N
3RT10 34-1A	3/17	LFO---	N	N
3RT10 34-1B	3/21	LDP---	N	N
3RT10 34-1X	4/16	LDP---	EAR99	N
3RT10 34-3A	3/17	LFO---	N	N
3RT10 34-3B	3/21	LDP---	N	N
3RT10 34-3K	4/15	LDP---	N	N
3RT10 34-3XB	4/16	LDP---	N	N
3RT10 34-3XF	4/16	LDP---	EAR99	N
3RT10 35-1A	3/17	LFO---	N	N
3RT10 35-1B	3/21	LDP---	N	N
3RT10 35-1X	4/16	LDP---	EAR99	N
3RT10 35-3A	3/17	LFO---	N	N
3RT10 35-3B	3/21	LDP---	N	N
3RT10 35-3K	4/15	LDP---	N	N
3RT10 35-3XB	4/16	LDP---	N	N
3RT10 35-3XF	4/16	LDP---	EAR99	N
3RT10 36-1A	3/17	LFO---	N	N
3RT10 36-1B	3/21	LDP---	N	N
3RT10 36-1X	4/16	LDP---	EAR99	N
3RT10 36-3A	3/17	LFO---	N	N
3RT10 36-3B	3/21	LDP---	N	N
3RT10 36-3K	4/15	LDP---	N	N
3RT10 36-3XB	4/16	LDP---	N	N
3RT10 36-3XF	4/16	LDP---	EAR99	N
3RT10 44-1A	3/18	LFO---	N	N
3RT10 44-1B	3/22	LDP---	N	N
3RT10 44-1X	4/16	LDP---	EAR99	N
3RT10 44-3A	3/18	LFO---	N	N
3RT10 44-3B	3/22	LDP---	N	N
3RT10 44-3K	4/15	LDP---	N	N
3RT10 44-3XB	4/16	LDP---	N	N
3RT10 44-3XF	4/16	LDP---	EAR99	N
3RT10 45-1A	3/18	LFO---	N	N
3RT10 45-1B	3/22	LDP---	N	N
3RT10 45-1X	4/16	LDP---	EAR99	N
3RT10 45-3A	3/18	LFO---	N	N
3RT10 45-3B	3/22	LDP---	N	N
3RT10 45-3K	4/15	LDP---	N	N
3RT10 45-3XB	4/16	LDP---	N	N
3RT10 45-3XF	4/16	LDP---	EAR99	N

Order No.	Page	Metal sur-charges	Export markings	
			ECCN	AL
3RT10 46-1A	3/18	LFO---	N	N
3RT10 46-1B	3/22	LDP---	N	N
3RT10 46-1X	4/16	LDP---	EAR99	N
3RT10 46-3A	3/18	LFO---	N	N
3RT10 46-3B	3/22	LDP---	N	N
3RT10 46-3K	4/15	LDP---	N	N
3RT10 46-3XB	4/16	LDP---	N	N
3RT10 46-3XF	4/16	LDP---	EAR99	N
3RT10 54-1A	3/23	LFO---	N	N
3RT10 54-1N	3/24	LFO---	EAR99	N
3RT10 54-1P	3/25	LFO---	EAR99	N
3RT10 54-1Q	3/25	LFO---	EAR99	N
3RT10 54-3A	3/23	LFO---	N	N
3RT10 54-3N	3/24	LFO---	EAR99	N
3RT10 55-2A	3/23	LFO---	N	N
3RT10 55-2N	3/24	LFO---	EAR99	N
3RT10 55-6A	3/23	LFO---	N	N
3RT10 55-6N	3/24	LFO---	EAR99	N
3RT10 55-6P	3/25	LFO---	EAR99	N
3RT10 55-6Q	3/25	LFO---	EAR99	N
3RT10 56-2A	3/23	LFO---	N	N
3RT10 56-2N	3/24	LFO---	EAR99	N
3RT10 56-6A	3/23	LFO---	N	N
3RT10 56-6N	3/24	LFO---	EAR99	N
3RT10 56-6P	3/25	LFO---	EAR99	N
3RT10 56-6Q	3/25	LFO---	EAR99	N
3RT10 64-2A	3/23	LFO---	N	N
3RT10 64-2N	3/24	LFO---	EAR99	N
3RT10 64-6A	3/23	LFO---	N	N
3RT10 64-6N	3/24	LFO---	EAR99	N
3RT10 64-6P	3/25	LFO---	EAR99	N
3RT10 64-6Q	3/25	LFO---	EAR99	N
3RT10 65-2A	3/23	LFO---	N	N
3RT10 65-2N	3/24	LFO---	EAR99	N
3RT10 65-6A	3/23	LFO---	N	N
3RT10 65-6N	3/24	LFO---	EAR99	N
3RT10 65-6P	3/25	LFO---	EAR99	N
3RT10 65-6Q	3/25	LFO---	EAR99	N
3RT10 66-2A	3/23	LFO---	N	N
3RT10 66-2N	3/24	LFO---	EAR99	N
3RT10 66-6A	3/23	LFO---	N	N
3RT10 66-6N	3/24	LFO---	EAR99	N
3RT10 66-6P	3/25	LFO---	EAR99	N
3RT10 66-6Q	3/25	LFO---	EAR99	N
3RT10 75-2A	3/23	LFO---	N	N
3RT10 75-2N	3/24	LFO---	EAR99	N
3RT10 75-6A	3/23	LFO---	N	N
3RT10 75-6N	3/24	LFO---	EAR99	N
3RT10 75-6P	3/25	LFO---	EAR99	N
3RT10 75-6Q	3/25	LFO---	EAR99	N
3RT10 76-2A	3/23	LFO---	N	N
3RT10 76-2N	3/24	LFO---	EAR99	N
3RT10 76-6A	3/23	LFO---	N	N
3RT10 76-6N	3/24	LFO---	EAR99	N
3RT10 76-6P	3/25	LFO---	EAR99	N
3RT10 76-6Q	3/25	LFO---	EAR99	N

Order No.	Page	Metal sur-charges	Export markings	
			ECCN	AL
3RT12				
3RT12 64-6A	3/28	L-O---	N	N
3RT12 64-6N	3/28	L-O---	EAR99	N
3RT12 65-6A	3/28	L-O---	N	N
3RT12 65-6N	3/28	L-O---	EAR99	N
3RT12 66-6A	3/28	L-O---	N	N
3RT12 66-6N	3/28	L-O---	EAR99	N
3RT12 75-6A	3/28	L-O---	N	N
3RT12 75-6N	3/28	L-O---	EAR99	N
3RT12 76-6A	3/28	L-O---	N	N
3RT12 76-6N	3/28	L-O---	EAR99	N
3RT13				
3RT13 16-1A	4/6	LFO---	N	N
3RT13 16-1B	4/7	LDP---	N	N
3RT13 16-2A	4/6	LFO---	N	N
3RT13 16-2B	4/7	LDP---	N	N
3RT13 17-1A	4/6	LFO---	N	N
3RT13 17-1B	4/7	LDP---	N	N
3RT13 17-2A	4/6	LFO---	N	N
3RT13 17-2B	4/7	LDP---	N	N
3RT13 25-1A	4/6	LFO---	N	N
3RT13 25-1B	4/7	LDP---	N	N
3RT13 26-1A	4/6	LFO---	N	N
3RT13 26-1B	4/7	LDP---	N	N
3RT13 36-1A	4/6	LFO---	N	N
3RT13 36-1B	4/7	LDP---	N	N
3RT13 44-1A	4/6	LFO---	N	N
3RT13 44-1B	4/7	LDP---	N	N
3RT13 46-1A	4/6	LFO---	N	N
3RT13 46-1B	4/7	LDP---	N	N
3RT14				
3RT14 46-1A	4/4	LFO---	N	N
3RT14 46-1B	4/4	LDP---	N	N
3RT14 56-6A	4/5	LFO---	N	N
3RT14 56-6N	4/5	LFO---	EAR99	N
3RT14 56-6P	4/5	LFO---	EAR99	N
3RT14 56-6Q	4/5	LFO---	EAR99	N
3RT14 66-6A	4/5	LFO---	N	N
3RT14 66-6N	4/5	LFO---	EAR99	N
3RT14 66-6P	4/5	LFO---	EAR99	N
3RT14 66-6Q	4/5	LFO---	EAR99	N
3RT14 76-6A	4/5	LFO---	N	N
3RT14 76-6N	4/5	LFO---	EAR99	N
3RT14 76-6P	4/5	LFO---	EAR99	N
3RT14 76-6Q	4/5	LFO---	EAR99	N
3RT15				
3RT15 16-1A	4/9	LFO---	N	N
3RT15 16-1B	4/9	LDP---	N	N
3RT15 16-2A	4/9	LFO---	N	N
3RT15 16-2B	4/9	LDP---	N	N
3RT15 17-1A	4/9	LFO---	N	N
3RT15 17-1B	4/9	LDP---	N	N
3RT15 17-2A	4/9	LFO---	N	N
3RT15 17-2B	4/9	LDP---	N	N
3RT15 26-1A	4/9	LFO---	N	N
3RT15 26-1B	4/9	LDP---	N	N

Order No.	Page	Metal sur-charges	Export markings	
			ECCN	AL
3RT15 35-1A	4/9	LFO---	N	N
3RT15 35-1B	4/9	LDP---	N	N
3RT16				
3RT16	4/11	LFO---	N	N
3RT19				
3RT19 00-1SB1	3/49	--	N	N
3RT19 00-1SB2	3/49, 7/47, 7/54, 7/62	--	N	N
3RT19 00-1SB6	3/49, 7/47, 7/54	--	N	N
3RT19 00-1SD	3/49, 7/47, 7/54	--	N	N
3RT19 00-4	3/48, 8/22	--	N	N
3RT19 16-1B	3/43, 5/8, 8/21	--	N	N
3RT19 16-1C	3/43, 5/8, 8/21	--	N	N
3RT19 16-1D	3/43, 5/8, 8/21	--	N	N
3RT19 16-1E	3/43, 5/8, 8/21	--	N	N
3RT19 16-1G	3/45, 5/8	--	N	N
3RT19 16-1J	3/43, 5/8	--	N	N
3RT19 16-1L	3/43, 5/8	--	N	N
3RT19 16-1P	3/45	--	N	N
3RT19 16-2BE	3/42, 5/9	LB----	EAR99	N
3RT19 16-2BK	3/42, 5/9	LB----	N	N
3RT19 16-2BL	3/42, 5/9	LB----	N	N
3RT19 16-2C	3/42	LB----	EAR99	N
3RT19 16-2D	3/42	LB----	EAR99	N
3RT19 16-2E	3/41	LB----	EAR99	N
3RT19 16-2F	3/41	LB----	EAR99	N
3RT19 16-2G	3/41	LB----	EAR99	N
3RT19 16-2L	3/41	LB----	EAR99	N
3RT19 16-4BA	3/74	L-P---	N	N
3RT19 16-4BB	3/49	L-P---	N	N
3RT19 16-4J	3/49, 5/9	--	N	N
3RT19 16-4K	3/48	L-P---	N	N
3RT19 16-4M	5/9	--	N	N
3RT19 16-4R	3/48, 8/22	--	N	N
3RT19 22	3/66	--	N	N
3RT19 24	3/50	L-R---	N	N
3RT19 26-1B	3/43 ... 44, 8/21	--	N	N
3RT19 26-1C	3/43, 8/21	--	N	N
3RT19 26-1E	3/43	--	N	N
3RT19 26-1Q	3/46	--	N	N
3RT19 26-1T	3/43, 8/21	--	N	N
3RT19 26-2C	3/42	LB----	EAR99	N
3RT19 26-2D	3/42	LB----	EAR99	N
3RT19 26-2E	3/41	LB----	EAR99	N
3RT19 26-2F	3/41	LB----	EAR99	N
3RT19 26-2G	3/41	LB----	EAR99	N
3RT19 26-2P	3/42	--	N	N
3RT19 26-3	3/45	--	N	N
3RT19 26-4BA	3/74	L-P---	N	N
3RT19 26-4BB	3/49	L-P---	N	N
3RT19 26-4C	3/74	L-P---	N	N
3RT19 26-4M	3/47	--	N	N
3RT19 26-4P	3/48	--	N	N
3RT19 26-4R	3/48, 8/22	--	N	N
3RT19 34-5A	3/50	L-R---	N	N
3RT19 34-5B	3/51	L-R---	N	N
3RT19 34-6	3/54	LJO---	N	N
3RT19 35-5	3/50	L-R---	N	N

Order No.	Page	Metal sur-charges	Export markings	
			ECCN	AL
3RT19 35-6	3/54	LJO---	N	N
3RT19 36-1	3/44, 8/21	--	N	N
3RT19 36-4BA	3/74	L-P---	N	N
3RT19 36-4BB	3/49	L-P---	N	N
3RT19 36-4E	3/47, 7/26, 7/46, 7/54	--	N	N
3RT19 36-6	3/54	LJO---	N	N
3RT19 36-7	3/54	--	N	N
3RT19 44-5AB	3/51	L-R---	N	N
3RT19 44-5AC	3/51	L-R---	N	N
3RT19 44-5AD	3/51	L-R---	N	N
3RT19 44-5AF	3/51	L-R---	N	N
3RT19 44-5AG	3/51	L-R---	N	N
3RT19 44-5AH	3/51	L-R---	N	N
3RT19 44-5AK	3/51	L-R---	N	N
3RT19 44-5AL	3/51	L-R---	N	N
3RT19 44-5AN2	3/51	L-R---	N	N
3RT19 44-5AN61	3/51	L-R---	N	N
3RT19 44-5AN62	3/51	L-R---	EAR99	N
3RT19 44-5AP	3/51	L-R---	N	N
3RT19 44-5AR	3/51	L-R---	N	N
3RT19 44-5AV	3/51	L-R---	N	N
3RT19 44-5B	3/51	L-R---	N	N
3RT19 44-6	3/54	LJO---	N	N
3RT19 45-5	3/51	L-R---	N	N
3RT19 45-6	3/54	LJO---	N	N
3RT19 46-4BA	3/74	L-P---	N	N
3RT19 46-4BB	3/49	L-P---	N	N
3RT19 46-4E	3/47, 7/26, 7/46, 7/54	--	N	N
3RT19 46-4F	3/46, 7/27	--	N	N
3RT19 46-4G	7/27	L-P---	N	N
3RT19 46-6	3/54	LJO---	N	N
3RT19 46-7	3/54	--	N	N
3RT19 54-6	3/54	LJO---	N	N
3RT19 54-7	3/54	--	N	N
3RT19 55-4	3/47, 7/54, 7/61	--	N	N
3RT19 55-5A	3/52	L-R---	N	N
3RT19 55-5NB	3/53	L-R---	EAR99	N
3RT19 55-5NF31	3/53	L-R---	EAR99	N
3RT19 55-5NF32	3/53	L-R---	N	N
3RT19 55-5NP	3/53	L-R---	EAR99	N
3RT19 55-5P	3/53	L-R---	EAR99	N
3RT19 55-5Q	3/53	L-R---	EAR99	N
3RT19 55-6	3/54	LJO---	N	N
3RT19 55-7	3/54	--	N	N
3RT19 56-1	3/44	--	N	N
3RT19 56-4B	3/49, 3/74	L-P---	N	N
3RT19 56-4E	3/47, 7/54, 7/61	--	N	N
3RT19 56-4G	3/47, 7/54, 7/61	--	N	N
3RT19 56-6	3/54	LJO---	N	N
3RT19 56-7	3/54	--	N	N
3RT19 64-6A	3/54	LJO---	N	N
3RT19 64-6V	3/54	--	N	N
3RT19 64-7	3/54	--	N	N
3RT19 65-5AB	3/52	L-R---	EAR99	N
3RT19 65-5AD31	3/52	L-R---	EAR99	N
3RT19 65-5AD32	3/52	L-R---	N	N
3RT19 65-5AF	3/52	L-R---	N	N

Order No.	Page	Metal sur-charges	Export markings	
			ECCN	AL
3RT19 65-5AM	3/52	L-R---	N	N
3RT19 65-5AP	3/52	L-R---	N	N
3RT19 65-5AR	3/52	L-R---	N	N
3RT19 65-5AS	3/52	L-R---	N	N
3RT19 65-5AT	3/52	L-R---	N	N
3RT19 65-5AU	3/52	L-R---	N	N
3RT19 65-5AV	3/52	L-R---	N	N
3RT19 65-5NB	3/53	L-R---	EAR99	N
3RT19 65-5NF31	3/53	L-R---	EAR99	N
3RT19 65-5NF32	3/53	L-R---	N	N
3RT19 65-5NP	3/53	L-R---	EAR99	N
3RT19 65-5P	3/53	L-R---	EAR99	N
3RT19 65-5Q	3/53	L-R---	EAR99	N
3RT19 65-6A	3/54	LJO---	N	N
3RT19 65-6V	3/54	--	N	N
3RT19 65-7	3/54	--	N	N
3RT19 66-1	3/44	--	N	N
3RT19 66-4B	3/49, 3/74	L-P---	N	N
3RT19 66-4E	3/47, 7/54, 7/61	--	N	N
3RT19 66-4G	3/47, 7/54, 7/61	--	N	N
3RT19 66-5AB	3/52	L-R---	EAR99	N
3RT19 66-5AD	3/52	L-R---	EAR99	N
3RT19 66-5AF	3/52	L-R---	N	N
3RT19 66-5AM	3/52	L-R---	N	N
3RT19 66-5AP	3/52	L-R---	N	N
3RT19 66-5AR	3/52	L-R---	N	N
3RT19 66-5AS	3/52	L-R---	N	N
3RT19 66-5AT	3/52	L-R---	N	N
3RT19 66-5AU	3/52	L-R---	N	N
3RT19 66-5AV	3/52	L-R---	N	N
3RT19 66-5N	3/53	L-R---	EAR99	N
3RT19 66-6A	3/54	LJO---	N	N
3RT19 66-6D	3/54	LJO---	N	N
3RT19 66-6V	3/54	--	N	N
3RT19 66-7	3/54	--	N	N
3RT19 75-5AB	3/52	L-R---	EAR99	N
3RT19 75-5AD31	3/52	L-R---	EAR99	N
3RT19 75-5AD32	3/52	L-R---	N	N
3RT19 75-5AF	3/52	L-R---	N	N
3RT19 75-5AM	3/52	L-R---	N	N
3RT19 75-5AP	3/52	L-R---	N	N
3RT19 75-5AR	3/52	L-R---	N	N
3RT19 75-5AS	3/52	L-R---	N	N
3RT19 75-5AT	3/52	L-R---	N	N
3RT19 75-5AU	3/52	L-R---	N	N
3RT19 75-5AV	3/52	L-R---	N	N
3RT19 75-5N	3/53	L-R---	EAR99	N
3RT19 75-5P	3/53	L-R---	EAR99	N
3RT19 75-5Q	3/53	L-R---	EAR99	N
3RT19 75-6A	3/54	LJO---	N	N
3RT19 75-6V	3/54	--	N	N
3RT19 75-7	3/54	--	N	N
3RT19 76-6A	3/54	LJO---	N	N
3RT19 76-6D	3/54	LJO---	N	N
3RT19 76-6V	3/54	--	N	N
3RT19 76-7	3/54	--	N	N

Order No.	Page	Metal sur-charges	Export markings	
			ECCN	AL
3RU				
3RU11	7/43 ... 7/45	L-O---	N	N
3RU19 00-1	7/46, 7/53	--	N	N
3RU19 00-2	7/46	L-O---	N	N
3RU19 1	7/46	--	N	N
3RU19 2	7/46	--	N	N
3RU19 3	7/46	--	N	N
3RU19 4	7/46	--	N	N
3RV				
3RV10 1	7/8, 7/9	LBP---	N	N
3RV10 2	7/8, 7/9	LBP---	N	N
3RV10 3	7/10	LBP---	N	N
3RV10 4	7/10	LBP---	N	N
3RV11	7/11	LAP---	N	N
3RV13	7/12	LAP---	N	N
3RV14	7/13	LAP---	N	N
3RV16 11-0	7/14	LAP---	N	N
3RV16 11-1	7/17	--	N	N
3RV17	7/15	LAO---	N	N
3RV18	7/16	LAO---	N	N
3RV19 01-0	7/19	--	N	N
3RV19 01-1	7/14, 7/17, 7/19, 8/20	L-P---	N	N
3RV19 01-2	7/19	L-P---	N	N
3RV19 02-1AB0	7/20	L-P---	N	N
3RV19 02-1AB4	7/20	--	N	N
3RV19 02-1AF	7/20	L-P---	N	N
3RV19 02-1AM	7/20	L-P---	N	N
3RV19 02-1AP	7/20, 8/20	L-P---	N	N
3RV19 02-1AS	7/20	L-P---	N	N
3RV19 02-1AV	7/20	L-P---	N	N
3RV19 02-1DB	7/20	L-P---	N	N
3RV19 02-1DF	7/20	L-P---	N	N
3RV19 02-1DP	7/20, 8/20	L-P---	N	N
3RV19 02-1DS	7/20	L-P---	N	N
3RV19 02-1DV	7/20	L-P---	N	N
3RV19 03	7/32	--	N	N
3RV19 08	7/26	--	N	N
3RV19 12	7/20	L-P---	N	N
3RV19 13	7/31 ... 32	--	N	N
3RV19 15-1	7/22	L-P---	N	N
3RV19 15-2	7/22	L-P---	N	N
3RV19 15-3	7/22	L-P---	N	N
3RV19 15-5	7/22	L-P---	N	N
3RV19 15-6	7/23	--	N	N
3RV19 17-1	7/35	L-P---	N	N
3RV19 17-4	7/35	L-P---	N	N
3RV19 17-5	7/35 ... 36	L-P---	N	N
3RV19 17-6	7/36	--	N	N
3RV19 17-7	7/35 ... 36	--	N	N
3RV19 18	7/27	L-P---	N	N
3RV19 21	7/20	L-P---	N	N
3RV19 22	7/20	L-P---	N	N
3RV19 23	7/31 ... 32	--	N	N
3RV19 25	3/74, 7/22	L-P---	N	N
3RV19 27	7/35	L-P---	N	N
3RV19 28	7/20, 7/27	L-P---	N	N
3RV19 33	7/31	--	N	N

Order No.	Page	Metal sur-charges	Export markings	
			ECCN	AL
3RV19 35-1	3/74, 7/22	L-P---	N	N
3RV19 35-3	7/22	L-P---	N	N
3RV19 35-5	3/74, 7/22	L-P---	N	N
3RV19 35-6	7/23	--	N	N
3RV19 36	7/25	L-P---	N	N
3RV19 38	7/20	L-P---	EAR99	N
3RV19 4	7/25	L-P---	N	N
3RV2	7/25	--	N	N
3NO				
3SB	7/46, 7/53	--	N	N
3SX	7/46, 7/53	--	N	N

Order No.	Page	Metal sur-charges	Export markings	
			ECCN	AL
3TX				
3TX	3/47	--	N	N
3ZX				
3ZX	8/25	--	N	N
8US				
8US10 1	7/23	L-P---	N	N
8US10 5	7/23, 7/29, 8/24	L-P---	N	N
8US10 6	7/23, 8/24	L-P---	N	N
8US11	7/23	L-P---	N	N
8US12	7/23, 7/29, 8/24	L-P---	N	N
8US19	7/29, 8/24 ... 25	--	N	N

-- No surcharge

Notes

Controls – Contactors and Contactor Assemblies – for Switching Motors

3



Price Groups

PG 41B, 41H

3/2

Introduction

Power Contactors for Switching Motors

3/5 General data

3/11 SIRIUS 3RT10 contactors,
3-pole, 3 ... 250 kW

3/27 SIRIUS 3RT12 vacuum contactors,
3-pole, 110 ... 250 kW

3/29 Accessories for 3RT1 contactors

3/50 Spare parts for 3RT1 contactors

Coupling Contactors

3/55 SIRIUS 3RT10 coupling contactors
(interface), 3-pole, 3 ... 11 kW

Contactor Assemblies

3RA13, 3RA14 Contactor Assemblies

3/59 SIRIUS 3RA13 reversing contactor
assemblies

3/67 SIRIUS 3RA14 contactor assemblies
for wye-delta starting

More information can be found on the Internet: [see the opening information, page 8](#)

Note:

Safety characteristics for contactors
see Catalog IC 10 · 2012
→ "Appendix" → "Standards and
Approvals" → "Overview"

Introduction

Overview

Size
Type**S00**
3RT10 1**S0**
3RT10 2**S2**
3RT10 3**3RT10 contactors**

Type	3RT10 15	3RT10 16	3RT10 17	3RT10 23	3RT10 24	3RT10 25	3RT10 26	3RT10 34	3RT10 35	3RT10 36
AC, DC operation	(p. 3/15, 3/19)			(p. 3/16, 3/20)			(p. 3/17, 3/21)			

-3 AC

I_e /AC-3/400 V	A	7	9	12	9	12	17	25	32	40	50
400 V	kW	3	4	5,5	4	5,5	7,5	11	15	18,5	22
230 V	kW	2,2	3	3	3	3	4	5,5	7,5	11	15
500 V	kW	3,5	4,5	5,5	4,5	7,5	10	11	18,5	22	30
690 V	3RT10/12 kW	4	5,5	5,5	5,5	7,5	11	11	18,5	22	22
1000 V	3RT10/12 kW	--	--	--	--	--	--	--	--	--	--

AC-4 (for $I_a = 6 \times I_e$)

400 V	kW	3	4	4	4	5,5	7,5	7,5	15	18,5	22
400 V	3RT10/12 kW	1,15	2	2	2	2,6	3,5	4,4	8,2	9,5	12,6
(200 000 operating cycles)											

AC-1 (40 °C, ≤ 690 V)

I_e	3RT10/12 A	18	22	22	40	40	40	40	50	60	60
-------	------------	-----------	-----------	-----------	-----------	-----------	-----------	-----------	-----------	-----------	-----------

3RT14 AC-1 contactors

Type				--					--		
I_e /AC-1/40 °C/≤ 690 V	A				--					--	

Accessories for contactors

Auxiliary switch blocks	On front Lateral	3RH19 11		(p. 3/35) (p. 3/39)	3RH19 21		(p. 3/35) (p. 3/39)	3RH19 21		(p. 3/35) (p. 3/39)
Terminal covers		--			--			3RT19 36-4EA2		(p. 3/47)
Box terminal blocks		--			--			--		
Surge suppressors		3RT19 16		(p. 3/43)	3RT19 26		(p. 3/43)	3RT19 26/36		(p. 3/44)

3RU1 and 3RB2 overload relays (Protection Equipment → Overload Relays)

3RU11 , thermal, CLASS 10	3RU11 16	0,1 ... 12 A (Chap. 7)	3RU11 26	1,8 ... 25 A (Chap. 7)	3RU11 36	5,5 ... 50 A (Chap. 7)
3RB20/21 , solid-state, CLASS 5, 10, 20 and 30	3RB20 16	0,1 ... 12 A (Chap. 7)	3RB20 26	3 ... 25 A (Chap. 7)	3RB20 36	6 ... 50 A (Chap. 7)
	3RB21 16		3RB21 26		3RB21 36	
3RB22/23 , solid-state, CLASS 5, 10, 20 and 30	3RB2. 83 + 3RB29 06	10 ... 100 A (Chap. 7)	3RB2. 83 + 3RB29 06	10 ... 100 A (Chap. 7)	3RB2. 83 + 3RB29 06	10 ... 100 A (Chap. 7)

3RV10 motor starter protectors (Protection Equipment → Motor Starter Protectors)

Type	3RV10 11	0,18 ... 12 A (Chap. 5)	3RV10 21	9 ... 25 A (Chap. 7)	3RV10 31	22 ... 50 A (Chap. 7)
Link modules	3RA19 11	(Chap. 5)	3RA19 21	(Chap. 7)	3RA19 31	(Chap. 7)

3RA13 Reversing Contactor Assemblies

Complete units	Typ e	3RA13 15	3RA13 16	3RA13 17	3RA13 24	3RA13 25	3RA13 26	3RA13 34	3RA13 35	3RA13 36
		(p. 3/60)			(p. 3/61)			(p. 3/62)		
400 V	kW	3	4	5,5	5,5	7,5	11	15	18,5	22
Assembly kits/wiring modules		3RA19 13-2A		(p. 3/65)	3RA19 23-2A		(p. 3/65)	3RA19 33-2A		(p. 3/65)
Mechanical interlocks		3RA19 12-2H		(p. 3/64)	3RA19 24-1A/-2B		(p. 3/64)	3RA19 24-1A/-2B		(p. 3/64)

3RA14 Contactor Assemblies for Wye-Delta Starting

Complete units	Typ e	3RA14 15	3RA14 16	3RA14 23	3RA14 25	3RA14 34	3RA14 35	3RA14 36	
		(p. 3/69)		(p. 3/70)		(p. 3/71)	(p. 3/72)		
400 V	kW	5,5	7,5	11	15/18,5	22/30	37	45	
Assembly kits/wiring modules		3RA19 13-2B		(p. 3/74)	3RA19 23-2B		(p. 3/74)	3RA19 33-2B/-2C	(p. 3/74)



S3
3RT1. 4



S6
3RT1. 5



S10
3RT1. 6



S12
3RT1. 7

3RT10 contactors • 3RT12 vacuum contactors

3RT10 44 (p. 3/18, 3/22)	3RT10 45	3RT10 46	3RT10 54 (p. 3/23)	3RT10 55	3RT10 56	3RT10 64 (p. 3/23)	3RT10 65	3RT10 66	3RT10 75 (p. 3/23)	3RT10 76
						3RT12 64 (p. 3/28)	3RT12 65	3RT12 66	3RT12 75 (p. 3/28)	3RT12 76

65	80	95	115	150	185	225	265	300	400	500
30	37	45	55	75	90	110	132	160	200	250
18,5	22	22	37	45	55	55	75	90	132	160
37	45	55	75	90	110	160	160	200	250	355
45	55	55	110	132	160	200	250	250	400	400/500
30	37	37	75	90	90	90/315	132/355	132/400	250/560	250/710

30	37	45	55	75	90	110	132	160	200	250
15,1	17,9	22	29	38	45	54/78	66/93	71/112	84/140	98/161

100	120	120	160	185	215	275/330	330	330	430/610	610
------------	------------	------------	------------	------------	------------	----------------	------------	------------	----------------	------------

3RT14 AC-1 contactors

3RT14 46 140	(Chap. 4)	3RT14 56 275	(Chap. 4)	3RT14 66 400	(Chap. 4)	3RT14 76 690	(Chap. 4)
------------------------	-----------	------------------------	-----------	------------------------	-----------	------------------------	-----------

Accessories for contactors

3RH19 21	(p. 3/35)	3RH19 21	(p. 3/35)
3RH19 21	(p. 3/39)	3RH19 21	(p. 3/39)
3RT19 46-4EA1/2	(p. 3/47)	3RT19 56-4EA1/2/3	(p. 3/47)
--		3RT19 55/56-4G	(p. 3/47)
3RT19 26/36	(p. 3/44)	3RT19 56-1C (RC element)	(p. 3/44)
		3RT19 66-4G	(p. 3/47)
		3RT19 66-1C (RC element)	(p. 3/44)

3RU1 and 3RB2 overload relays (Protection Equipment → Overload Relays)

3RU11 46	18 ... 100 A (Chap. 7)	--	--	--
3RB20 46 3RB21 46	12,5 ... 100 A (Chap. 7)	3RB20 56 3RB21 56	50 ... 200 A (Chap. 7)	3RB20 66 3RB21 66
3RB2. 83 + 3RB29 06	10 ... 100 A (Chap. 7)	3RB2. 83 + 3RB29 56	20 ... 200 A (Chap. 7)	3RB2. 83 + 3RB29 66
				63 ... 630 A (Chap. 7)

3RV10 motor starter protectors (Protection Equipment → Motor Starter Protectors)

3RV10 41	45 ... 100 A (Chap. 7)	--	--
3RA19 41	(Chap. 7)	--	--

3RA13 Reversing Contactor Assemblies

3RA13 44 (p. 3/63)	3RA13 45	3RA13 46	--	--	--
30	37	45	55	75	90
3RA19 43-2A	(p. 3/65)	3RA19 53-2A	(p. 3/65)	3RA19 63-2A	(p. 3/65)
3RA19 24-1A/-2B	(p. 3/64)	3RA19 54-2A	(p. 3/64)	3RA19 54-2A	(p. 3/64)
				110	132
				160	200
				250	3RA19 73-2A (p. 3/65)

3RA14 Contactor Assemblies for Wye-Delta Starting

3RA14 44 (p. 3/73)	3RA14 45	--	--	--
55	75	--	--	--
3RA19 43-2B/-2C	(p. 3/74)	3RA19 53-2B	(p. 3/74)	3RA19 63-2B
				(p. 3/74)
				3RA19 73-2B (p. 3/74)

Introduction

Note:

Safety characteristics for contactors see [Catalog IC 10, Chapter 16, "Appendix" → "Standards and Approvals" → "Overview"](#).

Connection methods

The contactors are available with screw terminals (box terminals or flat connectors) or with spring-type terminals.



Screw terminals



Spring-type terminals

The terminals are indicated in the corresponding tables by the symbols shown on orange backgrounds.

Overview

The SIRIUS family of controls

The SIRIUS modular system with its components for the switching, starting, protection and monitoring of motors and industrial systems stands for the fast, flexible and space-saving construction of control cabinets.

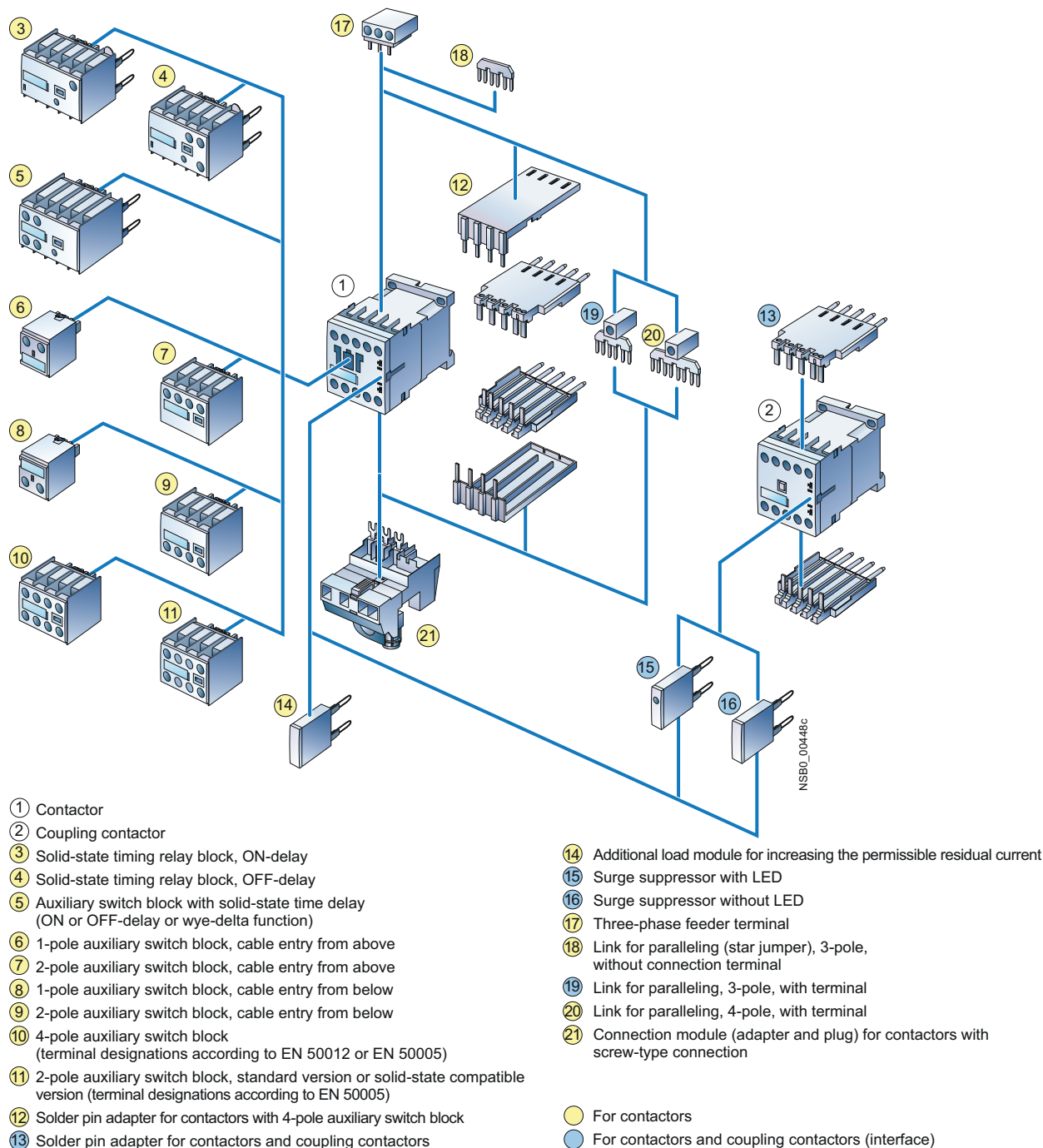
**3RT1 contactors and coupling contactors
Size S00 with mountable accessories**

Accessories see pages 3/35 to 3/49.

Reversing contactor assemblies see page 3/60.

Assembly kit for reversing contactor assemblies (mech. interlocking, wiring modules) see page 3/66.

Mountable overload relays see chapter 7, "Protection Equipment" → "Overload Relays".

Fuseless load feeders see chapter 8, "Load Feeders and Motor Starters" → "3RA Fuseless Load Feeders".

Power Contactors for Switching Motors

General data

3RT1 contactors

Sizes S0 to S3 with mountable accessories

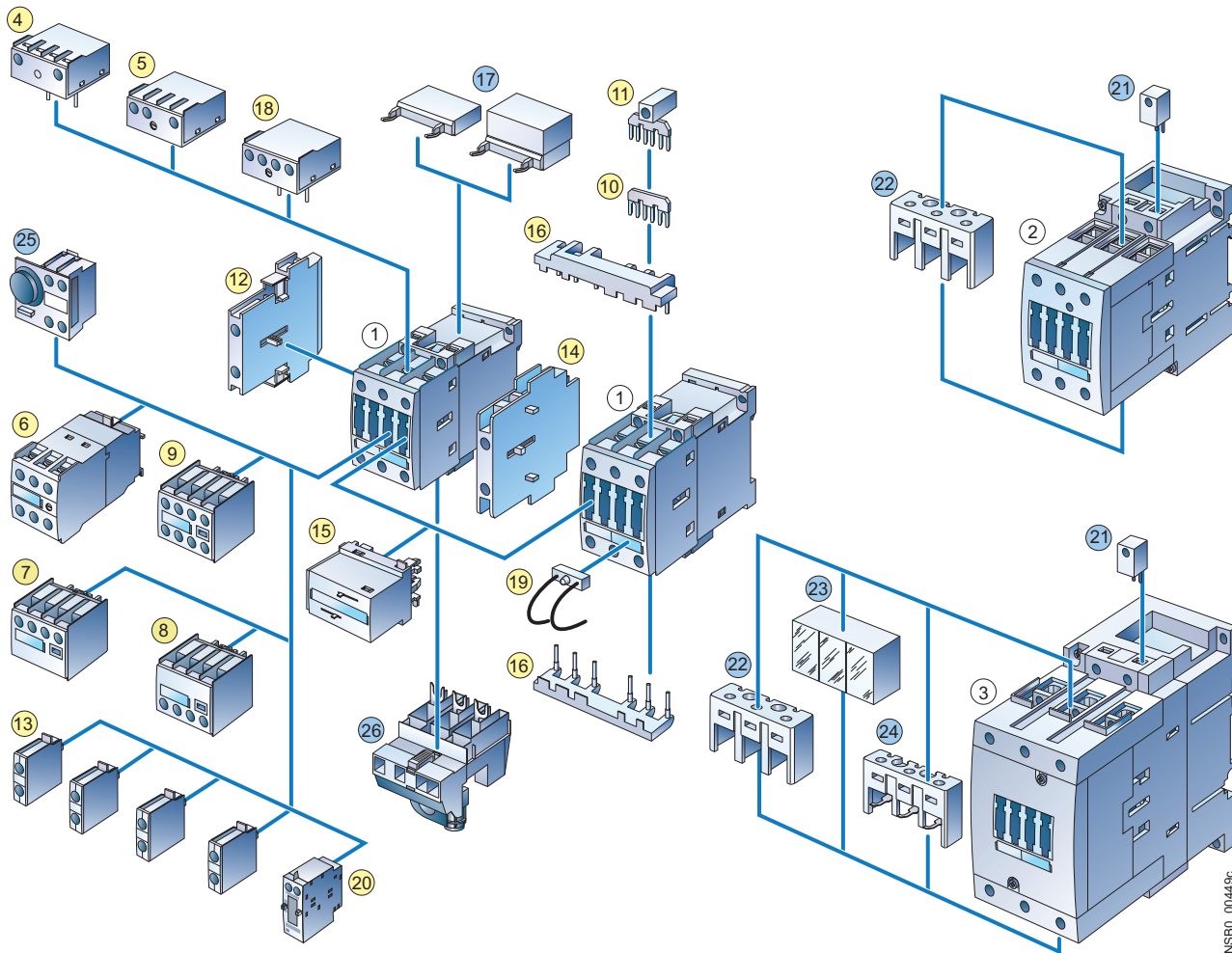

NSBC_00449c

- ① Contactor, size S0
- ② Contactor, size S2
- ③ Contactor, size S3

For sizes S0 to S3:

- ④ Solid-state time-delay block, ON-delay
- ⑤ Solid-state time-delay block, OFF-delay
- ⑥ Auxiliary switch block, solid-state time-delay (ON or OFF-delay or star-delta function)
- ⑦ 2-pole auxiliary switch block, cable entry from above
- ⑧ 2-pole auxiliary switch block, cable entry from below
- ⑨ 4-pole auxiliary switch block (terminal designations according to DIN EN 50,012 or DIN EN 50,005)
- ⑩ Link for paralleling (star jumper), 3-pole, without terminal
- ⑪ Link for paralleling, 3-pole, with terminal
- ⑫ 2-pole auxiliary switch block, laterally mountable left or right (terminal designations according to DIN EN 50012 or DIN EN 50005)
- ⑬ Single-pole auxiliary switch block (up to 4 can be snapped on)
- ⑭ Mechanical interlock, laterally mountable
- ⑮ Mechanical interlock, mountable to the front
- ⑯ Wiring connectors on the top and bottom (reversing duty)
- ⑰ Surge suppressors (page 3/186) (varistor, RC element, diode assembly), can be mounted on the top or bottom (different for S0 and S2/S3)

- ⑱ Coupling link (interface) for mounting directly onto contactor coil
- ⑲ LED module for indicating contactor operation

Only for size S0:

- ⑳ Pneumatic delay block
- ㉑ Connection module (adapter and connector)

Only for sizes S0 and S2:

- ㉒ Mechanical latching block

Only for sizes S2 to S3:

- ㉓ Coil repeat terminal for making contactor assemblies
- ㉔ Terminal cover for box terminal

Only for sizes S3:

- ㉕ Terminal cover for cable lug and bar connection
- ㉖ Auxiliary conductor terminal, 3-pole

● Accessories identical for sizes S0 to S3

● Accessories differ according to size

Accessories [see pages 3/35 to 3/49](#).

Reversing contactor assemblies [see pages 3/61 to 3/63](#).

3RT1 contactors
Sizes S6 to S12 with mountable accessories
(illustration for basic unit)

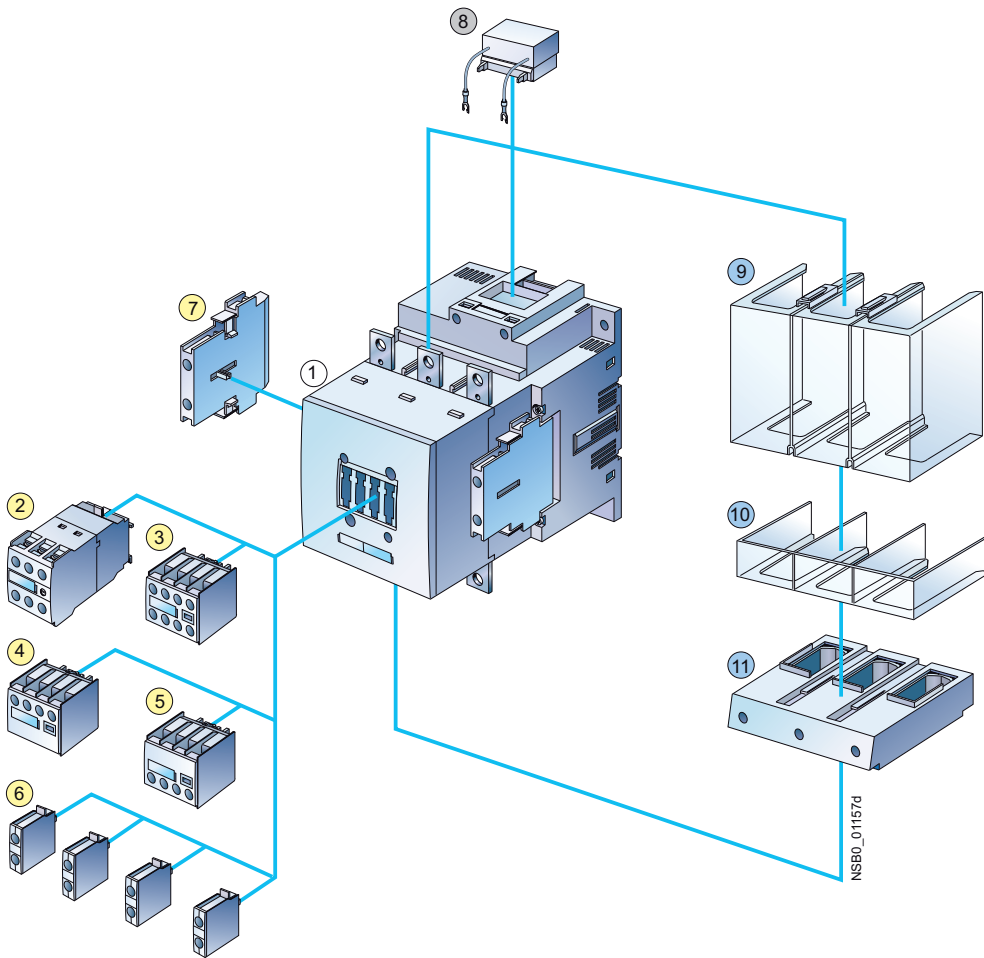

- ① 3RT10 and 3RT14 air-break contactors, sizes S6, S10 and S12
- ② Auxiliary switch block, solid-state time-delay (ON or OFF-delay or wye-delta function)
- ③ 4-pole auxiliary switch block (terminal designations according to EN 50012 or EN 50005)
- ④ 2-pole auxiliary switch block, cable entry from above
- ⑤ 2-pole auxiliary switch block, cable entry from below
- ⑥ Single-pole auxiliary switch block (up to 4 can be snapped on)
- ⑦ 2-pole auxiliary switch block, laterally mountable left or right (terminal designations according to EN 50012 or EN 50005) (identical for S0 to S12)
- ⑧ Surge suppressor (RC element) for plugging into top of withdrawable coil

- ⑨ Terminal cover for cable lug and busbar connection, different for sizes S6 and S10/S12
- ⑩ Terminal cover for box terminal, different for sizes S6 and S10/S12
- ⑪ Box terminal block, different for sizes S6 and S10/S12

- Accessories identical for sizes S0 to S12
- Accessories identical for sizes S6 to S12
- Accessories differ according to size

Accessories [see pages 3/35 to 3/49](#).

Mountable overload relays [see chapter 7, "Protection Equipment" → "Overload Relays"](#).

Power Contactors for Switching Motors

General data

3RA1 contactor assemblies, 3RT1 contactors
Size S6 with accessories

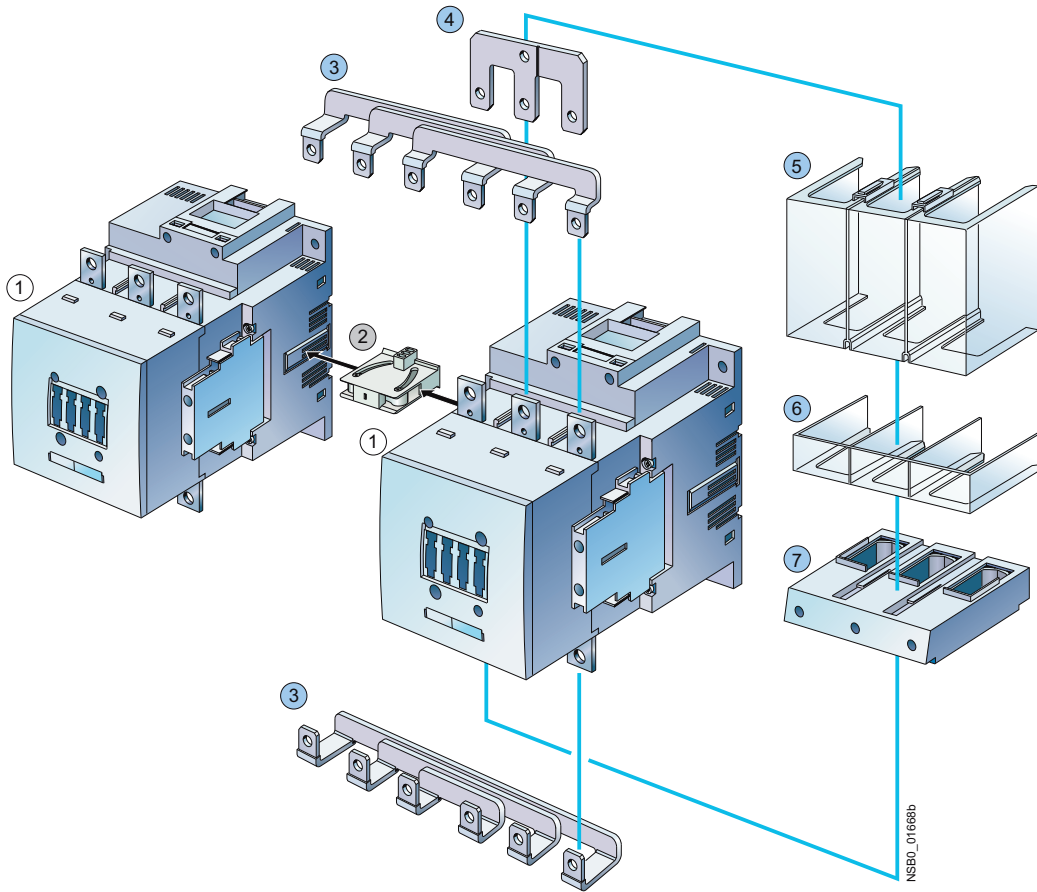

① 3RT10 and 3RT14 air-break contactor, size S6

② Mechanical interlock, laterally mountable

③ Wiring modules on the top and bottom, 3RA1953-2A

④ Link for paralleling (star jumper), 3-pole, with through-hole, 3RT1956-4BA31

⑤ Terminal cover for cable lug and bar connection different for sizes S6 and S10/S12

⑥ Terminal cover for box terminal different for sizes S6 and S10/S12

⑦ Box terminal block, different for sizes S6 and S10/S12

○ Accessories identical for sizes S6 to S12

● Accessories differ according to size

Accessories [see pages 3/35 to 3/49](#).

Components for reversing contactor assemblies [see pages 3/64 to 3/66](#).

Mountable overload relays [see chapter 7, "Protection Equipment" → "Overload Relays"](#).

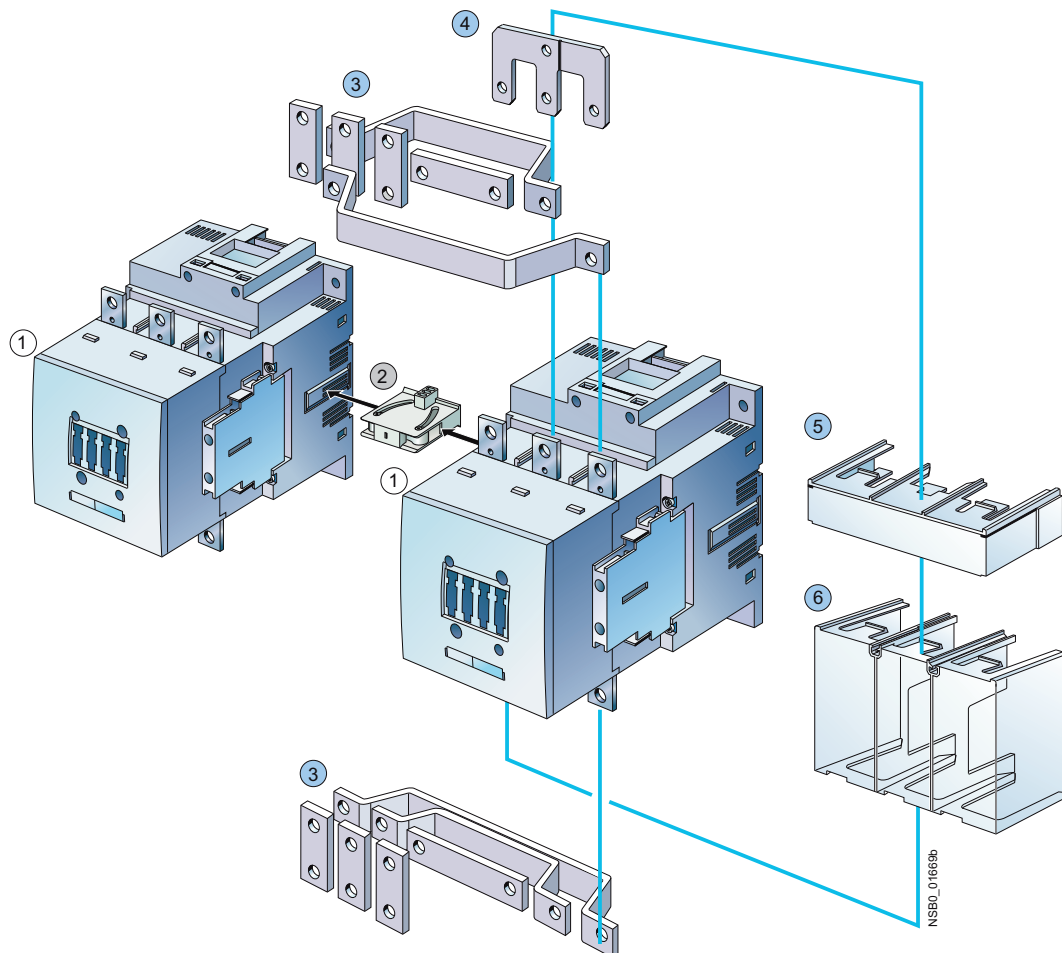
3RA1 contactor assemblies, 3RT1 contactors
Sizes S6, S10 and S12 with accessories

① 3RT10 and 3RT14 air-break contactor, sizes S6, S10 and S12 or
3RT12 vacuum contactor, sizes S10 and S12

② Mechanical interlock, laterally mountable

③ Wiring modules on the top and bottom, 3RA19

④ Link for paralleling (star jumper), 3-pole,
with through-hole, 3RT19 56-4BA31

⑤ Terminal cover for box terminal,
differs according to sizes S6 and S10/S12

⑥ Terminal cover for cable lug and busbar connection,
differs according to sizes S6 and S10/S12

○ Accessories identical for sizes S6 to S12

● Accessories differ according to size

Accessories [see pages 3/64 to 3/66 and 3/35 to 3/49](#).

Components for reversing contactor assemblies [see pages 3/64 to 3/66](#).

Mountable overload relays [see chapter 7, "Protection Equipment" → "Overload Relays"](#).

Power Contactors for Switching Motors

General data

3RT1 contactors

Sizes S6 to S12 with accessories and spare parts

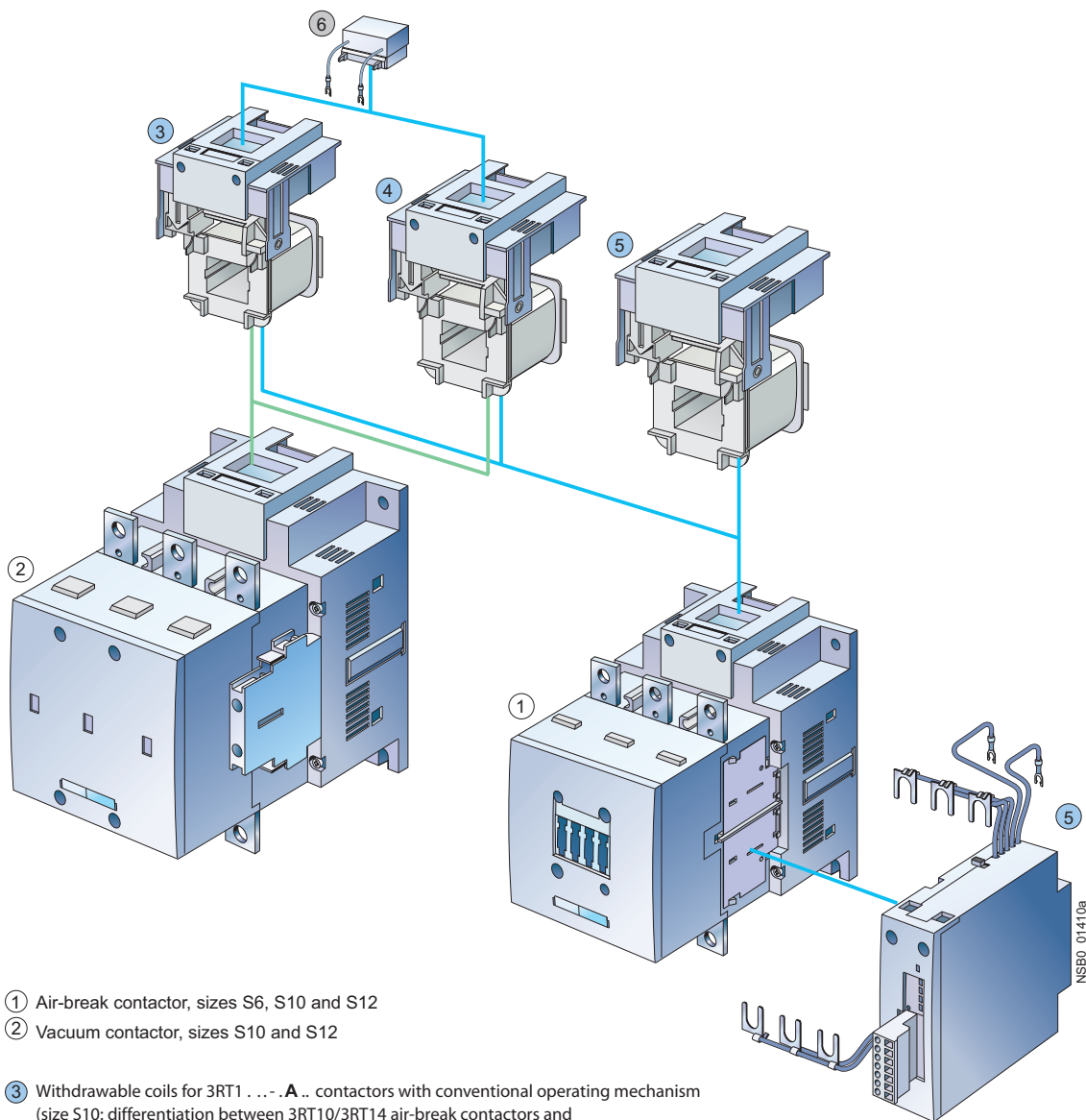

① Air-break contactor, sizes S6, S10 and S12

② Vacuum contactor, sizes S10 and S12

③ Withdrawable coils for 3RT1 **A** .. contactors with conventional operating mechanism
(size S10: differentiation between 3RT10/3RT14 air-break contactors and 3RT12 vacuum contactors)
(size S12: the same for air-break and vacuum contactors)

④ Withdrawable coils for 3RT1 **N** .. contactors with solid-state operating mechanism.
(size S10: differentiation between 3RT10/3RT14 air-break contactors and 3RT12 vacuum contactors)
(size S12: the same for air-break and vacuum contactors)

⑤ Withdrawable coils and laterally mountable module (plug-on) for 3RT1 **P** .. and 3RT1 **Q** .. air-break contactors with solid-state operating mechanism and remaining lifetime indicator

⑥ Surge suppressor (RC element), plug-mountable on withdrawable coils
• 3RT1 **A** .. with conventional operating mechanism
• 3RT1 **N** .. with solid-state operating mechanism.

● Identical for sizes S6 to S12

● Different according to size

Surge suppressors [see page 3/44](#),
withdrawable coils [see pages 3/52 and 3/53](#).

Mountable overload relays [see chapter 7](#),
"Protection Equipment" → "Overload Relays".

Overview

Standards

IEC 60947-1, EN 60947-1,
IEC 60947-4-1, EN 60947-4-1,
IEC 60947-5-1, EN 60947-5-1 (auxiliary switches)

The 3RT1 contactors are climate-proof. They are finger-safe according to EN 50274.

Connection methods

The 3RT1 contactors are available with screw terminals (box terminals) or spring-type terminals.

The size S3 contactors have removable box terminals for the main conductor connections. This permits connection of ring terminal lugs or busbars.

Contact reliability

If voltages ≤ 110 V and currents ≤ 100 mA are to be switched, the auxiliary contacts of the 3RT1 contactor or 3RH11 contactor relay should be used as they guarantee a high level of contact reliability.

These auxiliary contacts are particularly suitable for solid-state circuits with currents ≥ 1 mA at a voltage ≥ 17 V.

Short-circuit protection of the contactors

Short-circuit protection of contactors without overload relay see "Technical Specifications". Short-circuit protection of contactors with overload relay see the configuration manual "SIRIUS Configuration – Selection data for Fuseless Load Feeders" (see internet addresses for more information, page 8).

To assemble fuseless motor feeders you must select combinations of motor starter protector and contactor as explained in "Fuseless Load Feeders".

Motor protection

3RU11 thermal overload relays or 3RB20/3RB21 solid-state overload relays can be fitted to the 3RT1 contactors for protection against overload. The overload relays must be ordered separately.

Ratings of induction motors

The quoted rating (in kW) refers to the output power on the motor shaft (according to the nameplate).

Surge suppression

3RT1 contactors can be retrofitted with RC elements, varistors, diodes or diode assemblies (assembly of diode and Zener diode for short break times) for damping opening surges in the coil.

Note:

The OFF-delay of the NO contact and the ON-delay of the NC contact are increased if the contactor coils are attenuated against voltage peaks (noise suppression diode 6 to 10 times; diode assembly 2 to 6 times, varistor +2 to 5 ms).

Sizes S00 to S3, up to 45 kW

Auxiliary contact complement

Size S00 contactors have an auxiliary contact integrated in the basic unit. The basic units of sizes S0 to S3 are delivered only with the main contacts and can be extended with auxiliary switch blocks.

For sizes S0 to S3, complete units with mounted auxiliary switch block 2 NO + 2 NC are available (terminal designation according to EN 50012); the auxiliary switch block can be removed (for more information see "Accessories" on page 3/29).

Note:

Auxiliary contact complement according to SUVA: Contactors with permanently mounted auxiliary switch block 2 NO + 2 NC are available for safety applications according to SUVA.

Surge suppression

The surge suppressors are plugged onto the front of size S00 contactors. Space is provided for them next to a snap-on auxiliary switch block.

For size S0 to S3 contactors, varistors and RC elements can be snapped on either on the top or directly below the coil terminals. Diode assemblies are available in 2 different versions on account of their polarity. Depending on the application they can be connected either only at the bottom (assembly with motor starter protector) or only at the top (assembly with overload relay).

The plug-in direction of the diodes and diode assemblies is specified by coding.

Exceptions: 3RT19 26-1T.00 and 3RT19 36-1T.00; in this case the plug-in direction is marked with "+" and "-".

Coupling contactors are supplied either without overvoltage damping or with a varistor or diode connected as standard, according to the version.

Sizes S6 to S12, > 45 to 250 kW

- 3RT10, contactors for switching motors,
- 3RT12, vacuum contactors for switching motors,
- 3RT14, contactors for AC-1 applications (see Chapter 4).

Operating mechanism types

Two types of solenoid operation are available:

- Conventional operating mechanism
- Solid-state operating mechanism (with 3 performance levels)

Control supply voltage

The contactors have a UC operating mechanism which can be operated with AC (40 to 60 Hz) as well as with DC.

Withdrawable coils

For simple coil replacement, e. g. if the application is replaced, the solenoid coil can be pulled out upwards after the release mechanism has been actuated and can be replaced by any other coil of the same size.

Auxiliary contact complement

Contactors sizes S6 to S12 are supplied with mounted auxiliary switch blocks.

Detailed information about the fitting of auxiliary switches see "Accessories", page 3/29.

- 3RT10 and 3RT14 contactors:
Auxiliary contacts mounted laterally and on front
- 3RT12 vacuum contactors:
Auxiliary contacts mounted laterally

Contactors with conventional operating mechanism

Version 3RT1. ...A:

The solenoid coil is switched directly on and off with the control supply voltage U_s by way of terminals A1/A2.

Multi-voltage range for the control supply voltage U_s :

Only one coil covers several close-lying control supply voltages which are used worldwide, e. g. 110–115–120–127 V AC/DC or 220–230–240 V AC/DC. Allowance is made in addition for an operating range of 0.8 times the lower ($U_{s\ min}$) and 1.1 times the upper ($U_{s\ max}$) rated control supply voltage within which the contactor switches reliably and no thermal overload occurs.

Power Contactors for Switching Motors

SIRIUS 3RT10 contactors, 3-pole, 3 ... 250 kW

Contactors with solid-state operating mechanism

The solenoid coil is supplied selectively with the power required for reliable switching and holding by upstream control electronics.

- Wide voltage range for the control supply voltage U_s : Compared with the conventional operating mechanism, the solid-state operating mechanism covers an even broader range of control supply voltages used worldwide within one coil variant. For example, the coil for 200 to 277 V AC/DC ($U_{s \min}$ to $U_{s \max}$) covers the voltages 200-208-220-230-240-254-277 V used worldwide.
- Extended operating range 0.7 to $1.25 \times U_s$: The wide range for the rated control supply voltage and the additionally allowed coil operating range of $0.8 \times U_{s \min}$ to $1.1 \times U_{s \max}$ results in an extended coil operating range of at least 0.7 to $1.25 \times U_s$, within which the contactors will operate reliably, for the most common control supply voltages of 24, 110 and 230 V.
- Bridging temporary voltage dips: Control voltage failures dipping to 0 V (at A1/A2) are bridged for up to approx. 25 ms to avoid unintentional tripping.
- Defined ON and OFF thresholds: For voltages above $0.8 \times U_{s \min}$ the electronics will reliably switch the contactor ON, and for voltages below the value $0.5 \times U_{s \min}$ it is reliably switched OFF. The hysteresis in the switching thresholds prevents the main contacts from chattering as well as increased wear or welding when operated in weak, unstable networks. This also prevents thermal overloading of the contactor coil if the voltage applied is too low (contactor does not close properly and is continuously operated with overexcitation).
- Low control power consumption when closing and in the closed state.

Electromagnetic compatibility (EMC)

The contactors with solid-state operating mechanism conform to the requirements for operation in industrial plants:

- Interference immunity
 - Burst (IEC 61000-4-4): 4 kV
 - Surge (IEC 61000-4-5): 4 kV
 - Electrostatic discharge, ESD (IEC 61000-4-2): 8/15 kV
 - Electromagnetic field (IEC 61000-4-3): 10 V/m
- Emitted interference
 - Limit value class A according to EN 55011

Note:

In connection with converters, the control cables must be routed separately from the load cables to the converter.

Indication of remaining lifetime (RLT)

Main contactor contacts are working parts which therefore must be replaced in good time when the end of their service life has been reached. The degree of contact erosion and thus the electrical endurance (= number of operating cycles) depends on the loading, utilization category, operating mode, etc. Up to now, routine checks/visual inspections by the maintenance personnel were needed in order to gain an insight into the state of the main contacts.

The remaining lifetime indication function now takes over this task. It does not count the number of operating cycles – which does not provide information about contact erosion – but instead electronically identifies, evaluates and stores the actual progress of erosion of each one of the three main contacts, and outputs a warning when specified limits are reached. The stored data are not lost even if the control supply voltage for A1/A2 fails. After replacement of the main contacts, measurement the remaining lifetime must be reset using the "RESET" button (hold down RESET button for about 2 seconds using a pen or similar tool).

Advantages:

- Signaling through relay contact or AS-i when remaining lifetime is 20 %, i. e. contact material wear is 80 %.
- Additional visual indication of various levels of erosion by means of LEDs on the laterally mounted solid-state module when remaining lifetime is 60 % (green), 40 % (orange) and 20 % (red).

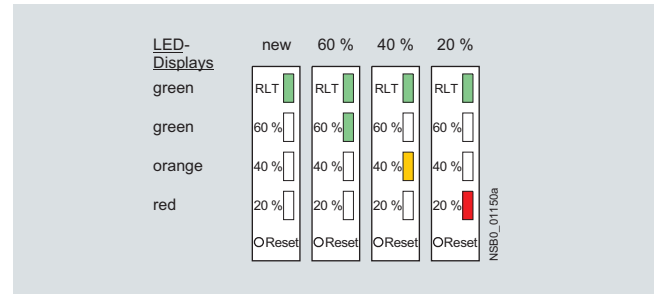

- Early warning to replace contacts
- Optimum utilization of contact material
- Visual inspection of the condition of contacts not necessary
- Reduction of ongoing operating costs
- Optimum planning of maintenance measures
- Avoidance of unforeseen plant downtimes

Version 3RT1...-N: for 24 V DC PLC output

2 control options:

- Control without a coupling link directly through a 24 V DC ≥ 30 mA PLC output (IEC 61131-2). Connection by means of 2-pole plug-in connection. The screwless spring-type connection is part of the scope of supply. The control supply voltage for supplying power to the solenoid operating mechanism must be connected to A1/A2.

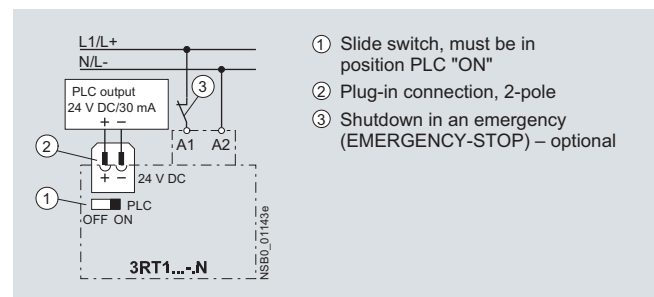

Note:

Before start-up, the slide switch for PLC operation must be moved to the "PLC ON" position (setting ex works: "PLC OFF").

- Conventional control by applying the control supply voltage at A1/A2 through a switching contact.

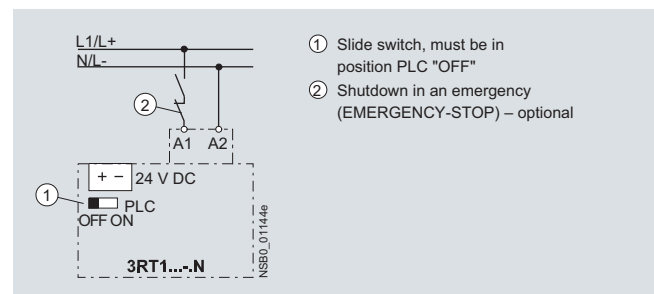

Note:

The slide switch must be in the "PLC OFF" position (= setting ex works).

Power Contactors for Switching Motors

SIRIUS 3RT10 contactors, 3-pole, 3 ... 250 kW

Version 3RT1...-P: for 24 V DC PLC output or PLC relay output, with remaining lifetime indicator (RLT).

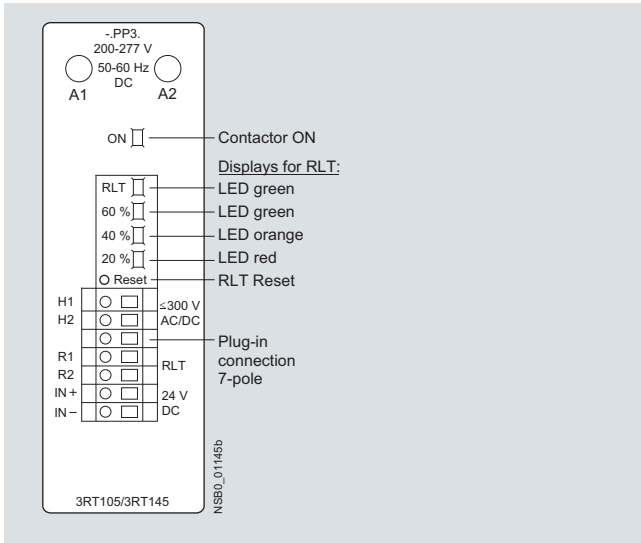

To supply the solenoid and the remaining lifetime indicator with power, the control supply voltage U_s must be connected to terminals A1/A2 of the laterally mounted solid-state module. The control inputs of the contactor are connected to a 7-pole plug-in connection; the screwless spring-type connection is part of the scope of supply.

- The "Remaining Lifetime RLT" status signal is available at terminals R1/R2 through a floating relay contact (hard gold-plated, enclosed) and can be input to SIMOCODE, PLC or other devices for processing, for example. Permissible load rating capacity of the R1/R2 relay output:
 - I_e/AC -15/24 to 230 V: 3 A
 - I_e/DC -13/24 V: 1 A
- LED indications
 - The following states are indicated by means of LEDs on the laterally mounted solid-state module:
 - Contactor ON (energized state): green LED ("ON")
 - Indication of remaining lifetime

2 control options:

- Contactor control without a coupling link directly through a 24 V DC ≥ 30 mA PLC output (IEC 61131-2) by way of terminals IN+/IN-.

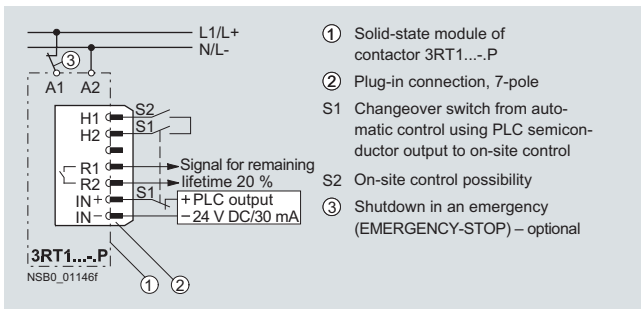

Possibility of switching from automatic control to local control by way of terminals H1/H2, i. e. automatic control through PLC or SIMOCODE/PROFIBUS DP can be deactivated e. g. at start-up or in the event of a fault and the contactor can be controlled manually.

- Contactor control through relay outputs at terminals H1/H2, e. g. by
 - PLC or
 - SIMOCODE

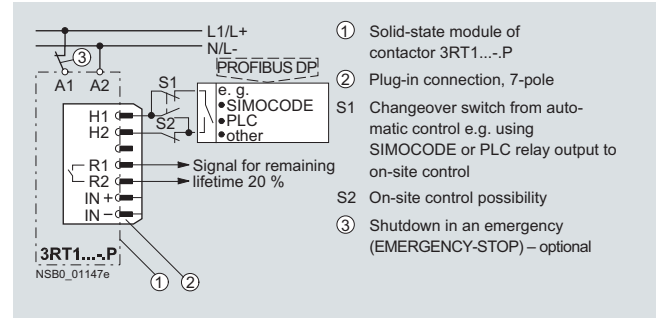

Contact loading: U_s /approx. 5 mA.

When operated through SIMOCODE, a communication link to PROFIBUS DP is also provided.

Version 3RT1...-Q: Communication-capable with integrated AS-Interface and remaining lifetime indicator (RLT)

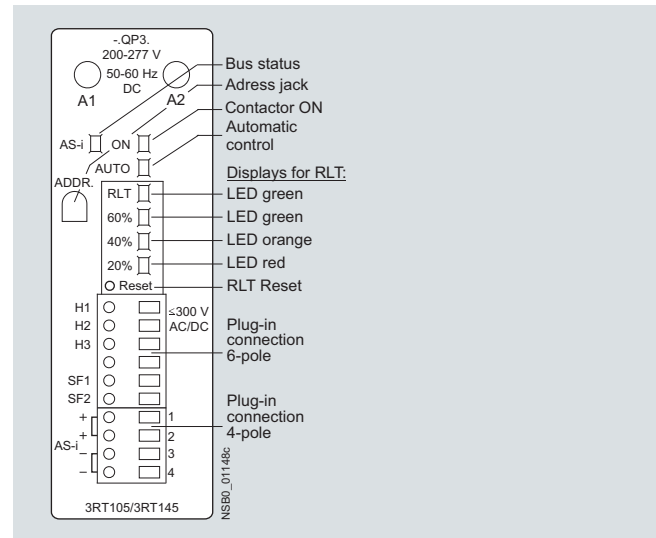

To supply the solenoid and the remaining lifetime indicator with power, the control supply voltage U_s must be connected to terminals A1/A2 of the laterally mounted solid-state module. The contactor itself is controlled by way of the integrated AS-Interface interface. The inputs and outputs are connected to a 10-pole plug-in connection; the screwless spring-type connections (6-pole for external connection and 4-pole for AS-Interface connection) are part of the scope of supply.

- LED displays:
 - The following states are indicated by means of LEDs on the laterally mounted solid-state module:
 - Contactor ON (energized state): green LED ("ON")
 - Automatic/local control: Green LED ("AUTO")
 - Bus status: Green/red dual LED ("AS-i")
 - Indication of remaining lifetime (RLT)
- AS-Interface addressing socket "ADDR":
 - The contactor address can be assigned after installation.

Power Contactors for Switching Motors

SIRIUS 3RT10 contactors, 3-pole, 3 ... 250 kW

Control circuit:

- Contactor control through AS-Interface by way of terminals AS-i +/AS-i -. Each of these terminals is jumpered and connected twice to a 4-pole connector which is separate from the other control inputs.

Advantages:

- The AS-Interface cable is not interrupted if the connector is pulled out
- The contactor remains functional through the local control inputs and its own 6-pole connector
- Control signals through AS-i:
 - Contactor ON/OFF
- Status signals through AS-i:
 - Contactor ON/OFF
 - Automatic/local control
 - Indication of remaining lifetime (RLT)
 - Signal through free input, e. g. overload relay tripped.

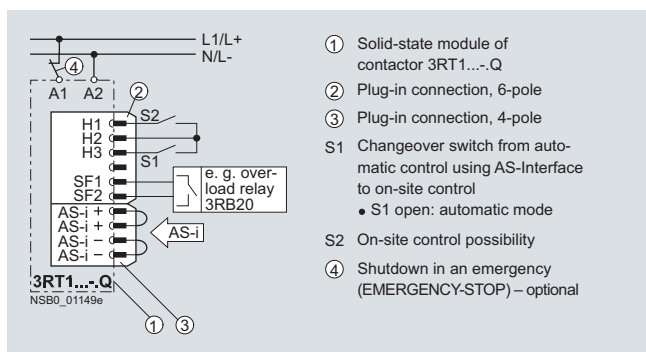

Possibility of switching from automatic control to local control by means of terminals H1/H2/H3, i. e. automatic control through AS-Interface can be deactivated e. g. during start-up or in the event of a fault and the contactor can be controlled manually.

Technical specifications

AS-Interface		
I/O configuration (hex)		7
ID code (hex)		F
Power supply (acc. to AS-Interface Spec.)	V	26,5 ... 31,6
Power consumption, max.	mA	20
Contact loading at SF1/2	mA	3 ... 6
Watchdog function (disconnects outputs in the event of AS-Interface fault)		Built-in

Indication behavior of the LEDs

State	LEDs
AS-Interface Communication OK	On
Fault	On
Station address 0 (zero)	Flashing
	Flashing

Contactor diagnostics using the user program

Inputs

Input signals	Device status
DI 0 "Ready"	0 Device not ready/manual operation 1 Device ready/automatic mode
DI 1 "Running"	0 Contactor off 1 Contactor on
DI 2 "Remaining lifetime"	0 Remaining lifetime RLT > 20 % 1 Remaining lifetime RLT ≤ 20 %
DI 3 "Free input"	0 No input signal at SF1/2 1 Input signal at SF1/2

Outputs

Output signals	Device status
DO 0 "Running"	0 Contactor off 1 Contactor on
DO 1	0 -- 1 --
DO 2	0 -- 1 --
DO 3	0 -- 1 --

Order No. scheme

Digit of the Order No.	1st - 3rd	4th	5th	6th	7th	8th	9th	10th	11th	12th	13th	14th	15th	16th
SIRIUS power contactors	3 R T													
1. generation	1													
Device type (e. g. 0 = 3-pole motor contactor, 3 = 4-pole AC-1 contactor)	0													
Size of the contactor (3 = S2, 4 = S3, 5 = S6, etc.)	4													
Power dependent on size (e. g. 45 = 37 kW)	5													
Connection type (1 = screw, 2 = spring)	1													
Operating range / solenoid coil circuit (e. g. A = AC standard / without)	A													
Rated control supply voltage (e. g. P0 = 230 V, 50 Hz)	P 0													
Auxiliary switches (e. g. S3: 0 = without auxiliary switches)	0													
Special version	0													
Example	3 R T 1 0 4 5 - 1 A P 0 0													

The Order No. scheme is presented here merely for information purposes and for better understanding of the logic behind the order numbers.

For your orders, please use the order numbers quote in the catalog and in the Industry Mall.

3RT10 contactors, 3-pole, 15 ... 250 kW



Selection and ordering data

AC operation

PU (UNIT, SET, M) = 1
 PS* = 1 unit
 PG = 41B



3RT10 1.-1AP04-3MA0

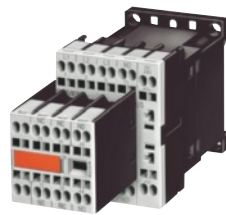

3RT10 1.-2AP04-3MA0



3RT10 1.-1A...



3RT10 1.-2A...

Rated data		Auxiliary contacts		Rated control supply voltage	DT	Screw terminals		DT	Spring-type terminals	
AC-2 and AC-3, T_U : Up to 60 °C		AC-1, T_U : 40 °C		at 50/60 Hz		⊕			⊞	
Operational current I_e up to 400 V	Rating of induction motors at 50 Hz and 400 V	Operational current I_e up to 690 V				Order No.	Price € per PU		Order No.	Price € per PU
A	kW	A	NO NC	V AC						

For screw and snap-on mounting onto TH 35 standard mounting rail

Size S00¹⁾

- With auxiliary contact 1 NO, Ident. No. **10**

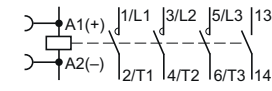

- With auxiliary contact 1 NC, Ident. No. **01**

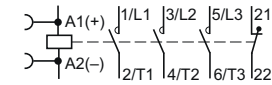

Rated current	Rated power	Rated voltage	Ident. No.	Auxiliary contacts	Control voltage	Order No.	Order No.
7	3	18	10	1	--	24	3RT10 15-1AB01
						110	3RT10 15-1AF01
						230	3RT10 15-1AP01
			01	--	1	24	3RT10 15-1AB02
						110	3RT10 15-1AF02
						230	3RT10 15-1AP02
9	4	22	10	1	--	24	3RT10 16-1AB01
						110	3RT10 16-1AF01
						230	3RT10 16-1AP01
			01	--	1	24	3RT10 16-1AB02
						110	3RT10 16-1AF02
						230	3RT10 16-1AP02
12	5,5	22	10	1	--	24	3RT10 17-1AB01
						110	3RT10 17-1AF01
						230	3RT10 17-1AP01
			01	--	1	24	3RT10 17-1AB02
						110	3RT10 17-1AF02
						230	3RT10 17-1AP02

With permanently mounted auxiliary switch block for safety applications according to SUVA

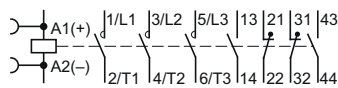

Rated current	Rated power	Rated voltage	Ident. No.	Auxiliary contacts	Control voltage	Order No.	Order No.
7	3	18	22	2	2	230	3RT10 15-1AP04-3MA0
							B 3RT10 15-2AP04-3MA0
9	4	22	22	2	2	230	3RT10 16-1AP04-3MA0
							B 3RT10 16-2AP04-3MA0
12	5,5	22	22	2	2	230	3RT10 17-1AP04-3MA0
							B 3RT10 17-2AP04-3MA0

Other voltages according to page 3/26 on request.

Accessories [see page 3/35](#).

Spare parts [see page 3/50](#).

Multi-unit packing and reusable packaging [see Catalog IC 10 · 2012, "Appendix" → "Ordering Notes"](#), size S00 on request.

¹⁾ For size S00: Coil operating range at 50 Hz: 0,8 ... 1,1 × U_S , at 60 Hz: 0,85 ... 1,1 × U_S .

Power Contactors for Switching Motors

3RT10 contactors, 3-pole, 15 ... 250 kW

AC operation

PU (UNIT, SET, M) = 1
 PS* = 1 unit
 PG = 41B



3RT10 2.-1A.04



3RT10 2.-1AL24-3MA0



3RT10 2.-1A.00



3RT10 2.-3A.00

Rated data		Auxiliary contacts		Rated control supply voltage U_s at 50 Hz	DT	Screw terminals	DT	Spring-type terminals for coil terminals	
AC-2 and AC-3, T_u : Up to 60 °C	AC-1, T_u : 40 °C	Ident. No.	Version			Order No.	Price € per PU	Order No.	Price € per PU
Operational current I_e up to 400 V	Rating of induction motors at 50 Hz and up to 400 V								
A	kW	A	NO NC	V AC					

For screw and snap-on mounting onto TH 35 standard mounting rail

Size S0

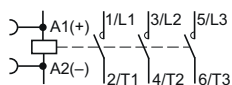

9	4	40 ¹⁾	--	--	--	24 110 230	▶ 3RT10 23-1AB00 ▶ 3RT10 23-1AF00 ▶ 3RT10 23-1AP00	B B ▶	3RT10 23-3AB00 3RT10 23-3AF00 3RT10 23-3AP00
12	5,5	40 ¹⁾	--	--	--	24 110 230	▶ 3RT10 24-1AB00 ▶ 3RT10 24-1AF00 ▶ 3RT10 24-1AP00	B B ▶	3RT10 24-3AB00 3RT10 24-3AF00 3RT10 24-3AP00
17	7,5	40 ¹⁾	--	--	--	24 110 230	▶ 3RT10 25-1AB00 ▶ 3RT10 25-1AF00 ▶ 3RT10 25-1AP00	B B ▶	3RT10 25-3AB00 3RT10 25-3AF00 3RT10 25-3AP00
25	11	40 ¹⁾	--	--	--	24 110 230	▶ 3RT10 26-1AB00 ▶ 3RT10 26-1AF00 ▶ 3RT10 26-1AP00	B B ▶	3RT10 26-3AB00 3RT10 26-3AF00 3RT10 26-3AP00

With mounted auxiliary switch block (removable)²⁾

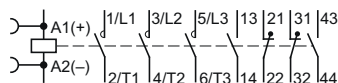

9	4	40 ¹⁾	22	2	2	24 110 230	▶ 3RT10 23-1AB04 ▶ 3RT10 23-1AF04 ▶ 3RT10 23-1AP04	-- -- --	-- -- --
12	5,5	40 ¹⁾	22	2	2	24 110 230	▶ 3RT10 24-1AB04 ▶ 3RT10 24-1AF04 ▶ 3RT10 24-1AP04	-- -- --	-- -- --
17	7,5	40 ¹⁾	22	2	2	24 110 230	▶ 3RT10 25-1AB04 ▶ 3RT10 25-1AF04 ▶ 3RT10 25-1AP04	-- -- --	-- -- --
25	11	40 ¹⁾	22	2	2	24 110 230	▶ 3RT10 26-1AB04 ▶ 3RT10 26-1AF04 ▶ 3RT10 26-1AP04	-- -- --	-- -- --

With permanently mounted auxiliary switch block for safety applications according to SUVA

At 50/60 Hz
V AC

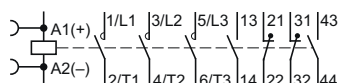

12	5,5	40 ¹⁾	22	2	2	230	B	3RT10 24-1AL24-3MA0	--
17	7,5	40 ¹⁾	22	2	2	230	A	3RT10 25-1AL24-3MA0	--
25	11	40 ¹⁾	22	2	2	230	A	3RT10 26-1AL24-3MA0	--

Other voltages according to page 3/26 on request.
 Accessories see page 3/35.
 Spare parts see page 3/50.

Multi-unit packing and reusable packaging see Catalog IC 10 - 2012, "Appendix" → "Ordering Notes", size S0 on request.

¹⁾ Minimum conductor cross-section 10 mm².

²⁾ Order No. for the auxiliary switch block (removable): 3RH19 21-1HA22 (2 NO + 2 NC according to EN 50012; 22).

Power Contactors for Switching Motors

**3RT10 contactors,
3-pole, 15 ... 250 kW**

AC operation

PU (UNIT, SET, M) = 1
 PS* = 1 unit
 PG = 41B



3RT10 3.-1A.04



3RT10 3.-1A.00



3RT10 3.-3A.00

Rated data		Auxiliary contacts		Rated control supply voltage	DT	Screw terminals		DT	Spring-type terminals for coil terminals	
AC-2 and AC-3, T _u : Up to 60 °C	AC-1, T _u : 40 °C	Ident. No.	Version	U _s at 50 Hz		Order No.	Price € per PU		Order No.	Price € per PU
Operational current I _e up to 500 V	Rating of induction motors at 50 Hz and 400 V		NO NC							
A	kW	A		V AC						

For screw and snap-on mounting onto TH 35 standard mounting rail

Size S2

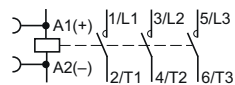

32	15	50	--	--	--	24 110 230	▶	3RT10 34-1AB00 3RT10 34-1AF00 3RT10 34-1AP00	B B ▶	3RT10 34-3AB00 3RT10 34-3AF00 3RT10 34-3AP00
40	18,5	60	--	--	--	24 110 230	▶	3RT10 35-1AB00 3RT10 35-1AF00 3RT10 35-1AP00	B B ▶	3RT10 35-3AB00 3RT10 35-3AF00 3RT10 35-3AP00
50	22	60	--	--	--	24 110 230	▶	3RT10 36-1AB00 3RT10 36-1AF00 3RT10 36-1AP00	B B ▶	3RT10 36-3AB00 3RT10 36-3AF00 3RT10 36-3AP00

With mounted auxiliary switch block (removable)¹⁾

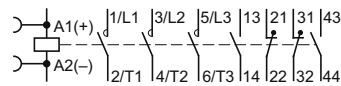

32	15	50	22	2	2	24 110 230	▶	3RT10 34-1AB04 3RT10 34-1AF04 3RT10 34-1AP04	-- -- --
40	18,5	60	22	2	2	24 110 230	▶	3RT10 35-1AB04 3RT10 35-1AF04 3RT10 35-1AP04	-- -- --
50	22	60	22	2	2	24 110 230	▶	3RT10 36-1AB04 3RT10 36-1AF04 3RT10 36-1AP04	-- -- --

With permanently mounted auxiliary switch block for safety applications according to SUVA

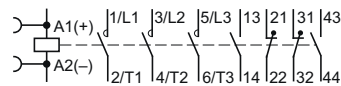

32	15	50	22	2	2	230	B	3RT10 34-1AP04-3MA0	--
40	18,5	60	22	2	2	230	B	3RT10 35-1AP04-3MA0	--
50	22	60	22	2	2	230	B	3RT10 36-1AP04-3MA0	--

Other voltages according to page 3/26 on request.

Accessories see page 3/35.

Spare parts see page 3/50.

Multi-unit packing and reusable packaging see Catalog IC 10 · 2012, "Appendix" → "Ordering Notes".

¹⁾ Order No. for the auxiliary switch block (removable): 3RH19 21-1HA22 (2 NO + 2 NC acc. to EN 50012; Ident. No. 22).

Power Contactors for Switching Motors

3RT10 contactors, 3-pole, 15 ... 250 kW

AC operation

PU (UNIT, SET, M) = 1
 PS* = 1 unit
 PG = 41B



3RT10 4.-1A.04



3RT10 4.-1A.00



3RT10 4.-3A.00

Rated data		Auxiliary contacts		Rated control supply voltage U_s at 50 Hz	DT	Screw terminals		DT	Spring-type terminals for coil terminals	
AC-2 and AC-3, T_U : Up to 60 °C	AC-1, T_U : 40 °C	Ident. No.	Version			Order No.	Price € per PU		Order No.	Price € per PU
Operational current I_e up to 500 V	Rating of induction motors at 50 Hz and 400 V	Operational current I_e up to 690 V								
A	kW	A	NO NC	V AC						

For screw and snap-on mounting onto TH 35 and TH 75 standard mounting rail

Size S3

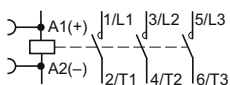

65	30	100	--	--	--	24 110 230	▶ 3RT10 44-1AB00 ▶ 3RT10 44-1AF00 ▶ 3RT10 44-1AP00	B B ▶	3RT10 44-3AB00 3RT10 44-3AF00 3RT10 44-3AP00
80	37	120	--	--	--	24 110 230	▶ 3RT10 45-1AB00 ▶ 3RT10 45-1AF00 ▶ 3RT10 45-1AP00	B B ▶	3RT10 45-3AB00 3RT10 45-3AF00 3RT10 45-3AP00
95	45	120	--	--	--	24 110 230	▶ 3RT10 46-1AB00 ▶ 3RT10 46-1AF00 ▶ 3RT10 46-1AP00	B B ▶	3RT10 46-3AB00 3RT10 46-3AF00 3RT10 46-3AP00

With mounted auxiliary switch block (removable)¹⁾

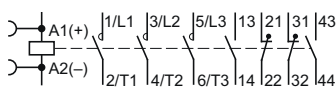

65	30	100	22	2	2	24 110 230	▶ 3RT10 44-1AB04 ▶ 3RT10 44-1AF04 ▶ 3RT10 44-1AP04	-- -- --	
80	37	120	22	2	2	24 110 230	▶ 3RT10 45-1AB04 ▶ 3RT10 45-1AF04 ▶ 3RT10 45-1AP04	B -- --	
95	45	120	22	2	2	24 110 230	▶ 3RT10 46-1AB04 ▶ 3RT10 46-1AF04 ▶ 3RT10 46-1AP04	B -- --	

With permanently mounted auxiliary switch block for safety applications according to SUVA

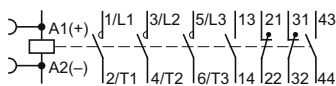

65	30	100	22	2	2	230	▶ 3RT10 44-1AP04-3MA0	--	
80	37	120	22	2	2	230	B ▶ 3RT10 45-1AP04-3MA0	--	
95	45	120	22	2	2	230	▶ 3RT10 46-1AP04-3MA0	--	

Other voltages according to page 3/26 on request.

Accessories see page 3/35.

Spare parts see page 3/51.

¹⁾ Order No. for the auxiliary switch block (removable): 3RH19 21-1HA22 (2 NO + 2 NC acc. to EN 50012; Ident. No. 22).

3RT10 contactors, 3-pole, 15 ... 250 kW

DC operation - DC solenoid system

PU (UNIT, SET, M) = 1
 PS* = 1 unit
 PG = 41B

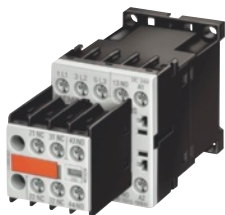

3RT10 1.-1BB44-3MA0

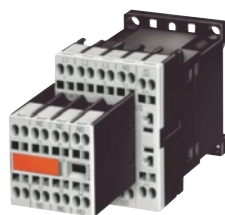

3RT10 1.-2BB44-3MA0



3RT10 1.-1B...



3RT10 1.-2B...

Rated data		Auxiliary contacts	Rated control supply voltage U_s	DT	Screw terminals	DT	Spring-type terminals	
AC-2 and AC-3, T_U : Up to 60 °C	AC-1, T_U : 40 °C	Ident. No.			Order No.	Price € per PU	Order No.	Price € per PU
Operational current I_e up to 400 V	Rating of induction motors at 50 Hz and up to 400 V	Version						
A	kW	NO NC	V DC					

For screw and snap-on mounting onto TH 35 standard mounting rail

Size S00

- With auxiliary contact 1 NO, Ident. No. 10

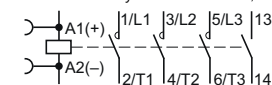

- With auxiliary contact 1 NC, Ident. No. 01

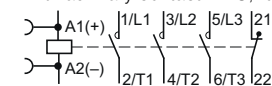

7	3	18	10	1	--	24		3RT10 15-1BB41		3RT10 15-2BB41
						220	A	3RT10 15-1BM41	B	3RT10 15-2BM41
			01	--	1	24	B	3RT10 15-1BB42	B	3RT10 15-2BB42
						220		3RT10 15-1BM42	B	3RT10 15-2BM42
9	4	22	10	1	--	24		3RT10 16-1BB41		3RT10 16-2BB41
						220	B	3RT10 16-1BM41	B	3RT10 16-2BM41
			01	--	1	24	B	3RT10 16-1BB42	B	3RT10 16-2BB42
						220		3RT10 16-1BM42	B	3RT10 16-2BM42
12	5,5	22	10	1	--	24		3RT10 17-1BB41		3RT10 17-2BB41
						220	B	3RT10 17-1BM41	B	3RT10 17-2BM41
			01	--	1	24	B	3RT10 17-1BB42	B	3RT10 17-2BB42
						220		3RT10 17-1BM42	B	3RT10 17-2BM42

With permanently mounted auxiliary switch block for safety applications according to SUVA

Terminal designations according to EN 50012

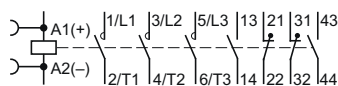

7	3	18	22	2	2	24		3RT10 15-1BB44-3MA0	B	3RT10 15-2BB44-3MA0
						24		3RT10 16-1BB44-3MA0 <td>A</td> <td>3RT10 16-2BB44-3MA0</td>	A	3RT10 16-2BB44-3MA0
						24		3RT10 17-1BB44-3MA0 <td>B</td> <td>3RT10 17-2BB44-3MA0</td>	B	3RT10 17-2BB44-3MA0

Other voltages according to page 3/26 on request.

Accessories [see page 3/35](#).

Spare parts [see page 3/51](#).

Multi-unit packing and reusable packaging [see Catalog IC 10 · 2012, "Appendix" → "Ordering Notes", size S00 on request](#).

Power Contactors for Switching Motors

3RT10 contactors, 3-pole, 15 ... 250 kW

DC operation - DC solenoid system

PU (UNIT, SET, M) = 1
 PS* = 1 unit
 PG = 41B



3RT10 2.-3B.44



3RT10 2.-1BB44-3MA0



3RT10 2.-1B.40



3RT10 2.-3B.40

Rated data		Auxiliary contacts		Rated control supply voltage U_s	DT	Screw terminals		DT	Spring-type terminals for coil terminals	
AC-2 and AC-3, T_U : Up to 60 °C	AC-1, T_U : 40 °C	Ident. No.	Version			Order No.	Price € per PU		Order No.	Price € per PU
Operational current I_e up to 400 V	Rating of induction motors at 50 Hz and 400 V	Operational current I_e up to 690 V								
A	kW	A	NO NC	V DC						

For screw and snap-on mounting onto TH 35 standard mounting rail

Size S0

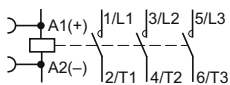

9	4	40 ¹⁾	--	--	--	24 220	▶ 3RT10 23-1BB40 B	▶ 3RT10 23-3BB40 B
12	5,5	40 ¹⁾	--	--	--	24 220	▶ 3RT10 24-1BB40 A	▶ 3RT10 24-3BB40 B
17	7,5	40 ¹⁾	--	--	--	24 220	▶ 3RT10 25-1BB40 A	▶ 3RT10 25-3BB40 B
25	11	40 ¹⁾	--	--	--	24 220	▶ 3RT10 26-1BB40 A	▶ 3RT10 26-3BB40 B

With mounted auxiliary switch block (removable)²⁾

Terminal designations according to DIN 50012

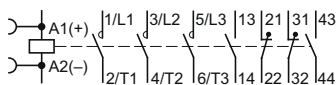

9	4	40 ¹⁾	22	2	2	24 220	▶ 3RT10 23-1BB44 B	▶ 3RT10 23-3BM40 B
12	5,5	40 ¹⁾	22	2	2	24 220	▶ 3RT10 24-1BB44 B	▶ 3RT10 24-3BM40 B
17	7,5	40 ¹⁾	22	2	2	24 220	▶ 3RT10 25-1BB44 B	▶ 3RT10 25-3BM40 B
25	11	40 ¹⁾	22	2	2	24 220	▶ 3RT10 26-1BB44 B	▶ 3RT10 26-3BM40 B

With permanently mounted auxiliary switch block for safety applications according to SUVA

Terminal designations according to DIN 50012

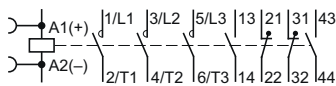

12	5,5	40 ¹⁾	22	2	2	24	A 3RT10 24-1BB44-3MA0	--
17	7,5	40 ¹⁾	22	2	2	24	A 3RT10 25-1BB44-3MA0	--
25	11	40 ¹⁾	22	2	2	24	A 3RT10 26-1BB44-3MA0	--

Other voltages according to page 3/26 on request.

Accessories see page 3/35.

Spare parts see page 3/51.

Multi-unit packing and reusable packaging see Catalog IC 10 · 2012, "Appendix" → "Ordering Notes", size S0 on request.

¹⁾ Minimum conductor cross-section 10 mm².

²⁾ Order No. for the auxiliary switch block (removable): 3RH19 21-1HA22 (2NO + 2NC according to EN 50012; 22E).

3RT10 contactors, 3-pole, 15 ... 250 kW

DC operation - DC solenoid system

PU (UNIT, SET, M) = 1
 PS* = 1 unit
 PG = 41B



3RT10 3.-1B.44



3RT10 3.-1B.40



3RT10 3.-3B.40

Rated data		Auxiliary contacts		Rated control supply voltage U_s	DT	Screw terminals	DT	Spring-type terminals for coil terminals	
AC-2 and AC-3, T_U : Up to 60 °C	AC-1, T_U : 40 °C	Ident. No.	Version			Order No.	Price € per PU	Order No.	Price € per PU
Operational current I_e up to 500 V	Rating of induction motors at 50 Hz and 400 V								
A	kW	A	NO NC	V DC					

For screw and snap-on mounting onto TH 35 standard mounting rail

Size S2

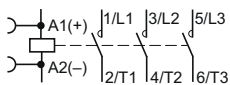

32	15	50	--	--	--	24 220	▶ 3RT10 34-1BB40 B 3RT10 34-1BM40	▶ 3RT10 34-3BB40 B 3RT10 34-3BM40
40	18,5	60	--	--	--	24 220	▶ 3RT10 35-1BB40 B 3RT10 35-1BM40	▶ 3RT10 35-3BB40 B 3RT10 35-3BM40
50	22	60	--	--	--	24 220	▶ 3RT10 36-1BB40 B 3RT10 36-1BM40	▶ 3RT10 36-3BB40 B 3RT10 36-3BM40

With mounted auxiliary switch block (removable)¹⁾

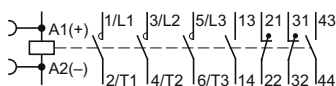

32	15	50	22	2	2	24 220	▶ 3RT10 34-1BB44 B 3RT10 34-1BM44	--
40	18,5	60	22	2	2	24 220	▶ 3RT10 35-1BB44 B 3RT10 35-1BM44	--
50	22	60	22	2	2	24 220	▶ 3RT10 36-1BB44 B 3RT10 36-1BM44	--

With permanently mounted auxiliary switch block for safety applications according to SUVA

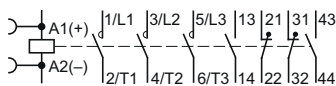

32	15	50	22	2	2	24	B 3RT10 34-1BB44-3MA0	--
40	18,5	60	22	2	2	24	B 3RT10 35-1BB44-3MA0	--
50	22	60	22	2	2	24	B 3RT10 36-1BB44-3MA0	--

Other voltages according to page 3/26 on request.

Accessories [see page 3/35](#).

Spare parts [see page 3/51](#).

Multi-unit packing and reusable packaging [see Catalog IC 10 · 2012, "Appendix" → "Ordering Notes"](#).

¹⁾ Order No. for the auxiliary switch block (removable): 3RH19 21-1HA22 (2 NO + 2 NC acc. to EN 50012; Ident. No. 22).

Power Contactors for Switching Motors

3RT10 contactors, 3-pole, 15 ... 250 kW

DC operation - DC solenoid system

PU (UNIT, SET, M) = 1
 PS* = 1 unit
 PG = 41B



3RT10 4.-1B.44



3RT10 4.-1B.40



3RT10 4.-3B.40

Rated data		Auxiliary contacts		Rated control supply voltage U_s	DT	Screw terminals		DT	Spring-type terminals for coil terminals	
AC-2 and AC-3, T_U : Up to 60 °C	AC-1, T_U : 40 °C	Ident. No.	Version			Order No.	Price € per PU		Order No.	Price € per PU
Operational current I_e up to 500 V	Rating of induction motors at 50 Hz and 400 V	Operational current I_e up to 690 V								
A	kW	A	NO NC	V DC						

For screw and snap-on mounting onto TH 35 and TH 75 standard mounting rail

Size S3

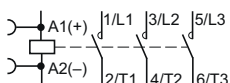

65	30	100	--	--	--	24 220	▶ 3RT10 44-1BB40 B 3RT10 44-1BM40	▶ 3RT10 44-3BB40 B 3RT10 44-3BM40
80	37	120	--	--	--	24 220	▶ 3RT10 45-1BB40 B 3RT10 45-1BM40	▶ 3RT10 45-3BB40 B 3RT10 45-3BM40
95	45	120	--	--	--	24 220	▶ 3RT10 46-1BB40 B 3RT10 46-1BM40	▶ 3RT10 46-3BB40 B 3RT10 46-3BM40

With mounted auxiliary switch block (removable)¹⁾

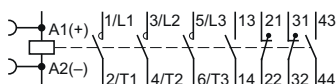

65	30	100	22	2	2	24 220	▶ 3RT10 44-1BB44 B 3RT10 44-1BM44	--
80	37	120	22	2	2	24 220	▶ 3RT10 45-1BB44 B 3RT10 45-1BM44	--
95	45	120	22	2	2	24 220	▶ 3RT10 46-1BB44 B 3RT10 46-1BM44	--

With permanently mounted auxiliary switch block for safety applications according to SUVA

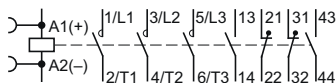

65	30	100	22	2	2	24	▶ 3RT10 44-1BB44-3MA0	--
80	37	120	22	2	2	24	▶ 3RT10 45-1BB44-3MA0	--
95	45	120	22	2	2	24	▶ 3RT10 46-1BB44-3MA0	--

Other voltages according to page 3/26 on request.

Accessories [see page 3/35](#).

Spare parts [see page 3/51](#).

¹⁾ Order No. for the auxiliary switch block (removable): 3RH19 21-1HA22 (2 NO + 2 NC acc. to EN 50012; Ident. No. 22).

3RT10 contactors, 3-pole, 15 ... 250 kW

AC/DC operation (40 Hz to 60 Hz, DC)

- Withdrawable coils with integrated surge suppression (varistor)
- Auxiliary and control conductors: Screw or spring-type terminals
- Main conductors: busbar connections, for 3RT10 54 (55 kW) box terminals¹⁾



3RT1. 5.

3RT1. 6.

3RT1. 7.

Size	Rated data	Auxiliary contacts, lateral	Rated control supply voltage U_s	DT	Order No.	Price € per PU	PU (UNIT, SET, M)	PS*	PG
	AC-2 and AC-3, T_U : Up to 60 °C	AC-1, T_U : 40 °C							
	Operational current I_e up to	Ratings of induction motors at 50 Hz and	Operational current I_e up to	Version					
	500 V	230 V 400 V 500 V 690 V	690 V	NO NC					
	A	kW kW kW kW	A	V AC/DC					

Conventional operating mechanisms

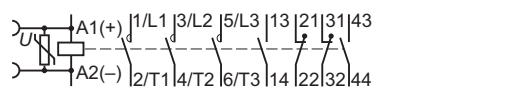

Screw terminals



S6	115	37	55	75	110	160	2	2	110 ... 127 220 ... 240	▶	3RT10 54-1AF36 3RT10 54-1AP36	1	1 unit	41B
	150	45	75	90	132	185	2	2	110 ... 127 220 ... 240	▶	3RT10 55-6AF36 3RT10 55-6AP36	1	1 unit	41B
	185	55	90	110	160	215	2	2	110 ... 127 220 ... 240	▶	3RT10 56-6AF36 3RT10 56-6AP36	1	1 unit	41B
S10	225	55	110	160	200	275	2	2	110 ... 127 220 ... 240	▶	3RT10 64-6AF36 3RT10 64-6AP36	1	1 unit	41B
	265	75	132	160	250	330	2	2	110 ... 127 220 ... 240	▶	3RT10 65-6AF36 3RT10 65-6AP36	1	1 unit	41B
	300	90	160	200	250	330	2	2	110 ... 127 220 ... 240	▶	3RT10 66-6AF36 3RT10 66-6AP36	1	1 unit	41B
S12	400	132	200	250	400	430	2	2	110 ... 127 220 ... 240	▶	3RT10 75-6AF36 3RT10 75-6AP36	1	1 unit	41B
	500	160	250	355	400	610	2	2	110 ... 127 220 ... 240	▶	3RT10 76-6AF36 3RT10 76-6AP36	1	1 unit	41B

Spring-type terminals

for coil and auxiliary switch terminals



S6	115	37	55	75	110	160	2	2	110 ... 127 220 ... 240	B	3RT10 54-3AF36 3RT10 54-3AP36	1	1 unit	41B
	150	45	75	90	132	185	2	2	110 ... 127 220 ... 240	B	3RT10 55-2AF36 3RT10 55-2AP36	1	1 unit	41B
	185	55	90	110	160	215	2	2	110 ... 127 220 ... 240	B	3RT10 56-2AF36 3RT10 56-2AP36	1	1 unit	41B
S10	225	55	110	160	200	275	2	2	110 ... 127 220 ... 240	B	3RT10 64-2AF36 3RT10 64-2AP36	1	1 unit	41B
	265	75	132	160	250	330	2	2	110 ... 127 220 ... 240	B	3RT10 65-2AF36 3RT10 65-2AP36	1	1 unit	41B
	300	90	160	200	250	330	2	2	110 ... 127 220 ... 240	B	3RT10 66-2AF36 3RT10 66-2AP36	1	1 unit	41B
S12	400	132	200	250	400	430	2	2	110 ... 127 220 ... 240	B	3RT10 75-2AF36 3RT10 75-2AP36	1	1 unit	41B
	500	160	250	355	400	610	2	2	110 ... 127 220 ... 240	B	3RT10 76-2AF36 3RT10 76-2AP36	1	1 unit	41B

Other voltages according to page 3/26 on request.

Accessories [see page 3/35](#).

Spare parts [see page 3/52](#).

¹⁾ Alternatively the 3RT10 54-1 contactor (55 kW) can be supplied with busbar connections instead of box terminals. Without additional price. In the 8th position of the Order No. the "1" must be replaced with "6" for screw terminals, e. g. 3RT10 54-6A.36; for spring-type terminals the "3" must be replaced by "2", e. g. 3RT10 54-2A.36.

Power Contactors for Switching Motors

3RT10 contactors, 3-pole, 15 ... 250 kW

AC/DC operation (40 Hz to 60 Hz, DC)

- Withdrawable coils with integrated surge suppression (varistor)
- Auxiliary and control conductors: Screw or spring-type terminals
- Main conductors: busbar connections, for 3RT10 54 (55 kW) box terminals¹⁾



3RT1. 5.



3RT1. 6.



3RT1. 7.

Size	Rated data	Auxiliary contacts, lateral	Rated control supply voltage U_s	DT	Order No.	Price € per PU	PU (UNIT, SET, M)	PS*	PG
	AC-2 and AC-3, T_U : Up to 60 °C	AC-1, T_U : 40 °C							
	Operational current I_e up to	Ratings of induction motors at 50 Hz and	Operational current I_e up to	Version					
	500 V	230 V 400 V 500 V 690 V	690 V	NO NC					
	A	kW kW kW kW	A	V AC/DC					

Solid-state operating mechanisms · for 24 V DC PLC output

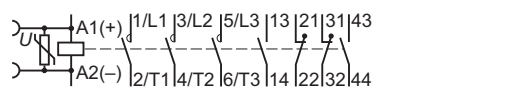

Screw terminals



S6	115	37	55	75	110	160	2	2	96 ... 127 200 ... 277	A	3RT10 54-1NF36 3RT10 54-1NP36	1	1 unit	41B
	150	45	75	90	132	185	2	2	96 ... 127 200 ... 277	A	3RT10 55-6NF36 3RT10 55-6NP36	1	1 unit	41B
	185	55	90	110	160	215	2	2	96 ... 127 200 ... 277	A	3RT10 56-6NF36 3RT10 56-6NP36	1	1 unit	41B
S10	225	55	110	160	200	275	2	2	96 ... 127 200 ... 277	A	3RT10 64-6NF36 3RT10 64-6NP36	1	1 unit	41B
	265	75	132	160	250	330	2	2	96 ... 127 200 ... 277	A	3RT10 65-6NF36 3RT10 65-6NP36	1	1 unit	41B
	300	90	160	200	250	330	2	2	96 ... 127 200 ... 277	B	3RT10 66-6NF36 3RT10 66-6NP36	1	1 unit	41B
S12	400	132	200	250	400	430	2	2	96 ... 127 200 ... 277	A	3RT10 75-6NF36 3RT10 75-6NP36	1	1 unit	41B
	500	160	250	355	400	610	2	2	96 ... 127 200 ... 277	A	3RT10 76-6NF36 3RT10 76-6NP36	1	1 unit	41B

Spring-type terminals for coil and auxiliary switch terminals



S6	115	37	55	75	110	160	2	2	96 ... 127 200 ... 277	B	3RT10 54-3NF36 3RT10 54-3NP36	1	1 unit	41B
	150	45	75	90	132	185	2	2	96 ... 127 200 ... 277	B	3RT10 55-2NF36 3RT10 55-2NP36	1	1 unit	41B
	185	55	90	110	160	215	2	2	96 ... 127 200 ... 277	B	3RT10 56-2NF36 3RT10 56-2NP36	1	1 unit	41B
S10	225	55	110	160	200	275	2	2	96 ... 127 200 ... 277	B	3RT10 64-2NF36 3RT10 64-2NP36	1	1 unit	41B
	265	75	132	160	250	330	2	2	96 ... 127 200 ... 277	B	3RT10 65-2NF36 3RT10 65-2NP36	1	1 unit	41B
	300	90	160	200	250	330	2	2	96 ... 127 200 ... 277	B	3RT10 66-2NF36 3RT10 66-2NP36	1	1 unit	41B
S12	400	132	200	250	400	430	2	2	96 ... 127 200 ... 277	B	3RT10 75-2NF36 3RT10 75-2NP36	1	1 unit	41B
	500	160	250	355	400	610	2	2	96 ... 127 200 ... 277	B	3RT10 76-2NF36 3RT10 76-2NP36	1	1 unit	41B

Other voltages according to page 3/26 on request.

Accessories [see page 3/39](#).

Spare parts [see page 3/53](#).

¹⁾ Alternatively the 3RT10 54-1 contactor (55 kW) can be supplied with busbar connections instead of box terminals. Without additional price. In the 8th position of the Order No. the "1" must be replaced with "6" for screw terminals, e. g. 3RT10 54-6A.36; for spring-type terminals the "3" must be replaced by "2", e. g. 3RT10 54-2A.36.

3RT10 contactors, 3-pole, 15 ... 250 kW

AC/DC operation (40 Hz to 60 Hz, DC)

- Withdrawable coils with integrated surge suppression (varistor)
- Auxiliary and control conductors: Screw terminals
- Main conductors: busbar connections, for 3RT10 54 (55 kW) box terminals¹⁾
- Indication of remaining lifetime (RLT)



3RT10 56-6P..

3RT10 56-6Q..

Size	Rated data					AC-1, T _U : 40 °C	Auxiliary contacts, lateral		Rated control supply voltage U _s	DT	Screw terminals	⊕	PU (UNIT, SET, M)	PS*	PG
	AC-2 and AC-3, T _U : Up to 60 °C						Version								
	Operational current I _e up to	Ratings of induction motors at 50 Hz and up to				Operational current I _e up to	NO	NC	V AC/DC		Order No.	Price € per PU			
	500 V	230 V	400 V	500 V	690 V	690 V									
	A	kW	kW	kW	kW	A									

Solid-state operating mechanisms · with 24 V DC PLC relay output · with RLT

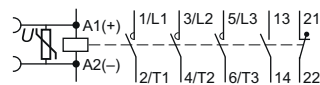

S6	115	37	55	75	110	160	1	1	96 ... 127 200 ... 277	B	3RT10 54-1PF35		1	1 unit	41B
										B	3RT10 54-1PP35		1	1 unit	41B
	150	45	75	90	132	185	1	1	96 ... 127 200 ... 277	B	3RT10 55-6PF35		1	1 unit	41B
										B	3RT10 55-6PP35		1	1 unit	41B
S10	185	55	90	110	160	215	1	1	96 ... 127 200 ... 277	B	3RT10 56-6PF35		1	1 unit	41B
										B	3RT10 56-6PP35		1	1 unit	41B
	225	55	110	160	200	275	1	1	96 ... 127 200 ... 277	B	3RT10 64-6PF35		1	1 unit	41B
										B	3RT10 64-6PP35		1	1 unit	41B
S12	265	75	132	160	250	330	1	1	96 ... 127 200 ... 277	B	3RT10 65-6PF35		1	1 unit	41B
										B	3RT10 65-6PP35		1	1 unit	41B
	300	90	160	200	250	330	1	1	96 ... 127 200 ... 277	B	3RT10 66-6PF35		1	1 unit	41B
										B	3RT10 66-6PP35		1	1 unit	41B
S12	400	132	200	250	400	430	1	1	96 ... 127 200 ... 277	B	3RT10 75-6PF35		1	1 unit	41B
										B	3RT10 75-6PP35		1	1 unit	41B
	500	160	250	355	400	610	1	1	96 ... 127 200 ... 277	B	3RT10 76-6PF35		1	1 unit	41B
										B	3RT10 76-6PP35		1	1 unit	41B

Solid-state operating mechanisms · with AS-Interface · with RLT

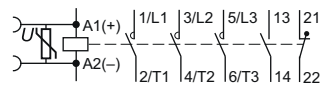

S6	115	37	55	75	110	160	1	1	96 ... 127 200 ... 277	B	3RT10 54-1QF35		1	1 unit	41B
										B	3RT10 54-1QP35		1	1 unit	41B
	150	45	75	90	132	185	1	1	96 ... 127 200 ... 277	B	3RT10 55-6QF35		1	1 unit	41B
										B	3RT10 55-6QP35		1	1 unit	41B
S10	185	55	90	110	160	215	1	1	96 ... 127 200 ... 277	B	3RT10 56-6QF35		1	1 unit	41B
										B	3RT10 56-6QP35		1	1 unit	41B
	225	55	110	160	200	275	1	1	96 ... 127 200 ... 277	B	3RT10 64-6QF35		1	1 unit	41B
										B	3RT10 64-6QP35		1	1 unit	41B
S12	265	75	132	160	250	330	1	1	96 ... 127 200 ... 277	B	3RT10 65-6QF35		1	1 unit	41B
										B	3RT10 65-6QP35		1	1 unit	41B
	300	90	160	200	250	330	1	1	96 ... 127 200 ... 277	B	3RT10 66-6QF35		1	1 unit	41B
										B	3RT10 66-6QP35		1	1 unit	41B
S12	400	132	200	250	400	430	1	1	96 ... 127 200 ... 277	B	3RT10 75-6QF35		1	1 unit	41B
										B	3RT10 75-6QP35		1	1 unit	41B
	500	160	250	355	400	610	1	1	96 ... 127 200 ... 277	B	3RT10 76-6QF35		1	1 unit	41B
										B	3RT10 76-6QP35		1	1 unit	41B

Other voltages according to page 3/26 on request.
Accessories [see page 3/39](#).
Spare parts [see page 3/53](#).

¹⁾ Alternatively the 3RT10 54-1 contactor (55 kW) can be supplied with busbar connections instead of box terminals. Without additional price. In the 8th position of the Order No. the "1" must be replaced with "6", e.g. 3RT10 54-6..35.

Power Contactors for Switching Motors

3RT10 contactors, 3-pole, 15 ... 250 kW

Options

Rated control supply voltages, possible on request (the 10th and 11th position of the order number must be changed)

Rated control supply voltage U_s	Contactor type	3RT10 1	3RT10 2, 3RT10 3, 3RT10 4	3RT14 4	3RT13 1, 3RT15 1	3RT13 2 ... 3RT13 4, 3RT15 2, 3RT15 3	3RT16 17, 3RT16 27, 3RT16 47
	Size	S00	S0, S2, S3	S3	S00	S0, S2, S3	S00, S0, S3

Sizes S2 and S3

AC operation

Solenoid coils for 50 Hz¹⁾

24 V AC	B0	B0	B0	B0	B0	B0	B0
42 V AC	D0	D0	D0	D0	D0	--	--
48 V AC	H0	H0	H0	H0	H0	--	--
110 V AC	F0	F0	F0	F0	F0	F0	F0
230 V AC	P0	P0	P0	P0	P0	P0	P0
240 V AC	U0	U0	U0	U0	U0	U0	U0
400 V AC	V0	V0	V0	V0	V0	V0	V0

Solenoid coils for 50 and 60 Hz¹⁾

24 V AC	B0	C2	C2	B0	C2	C2	C2
42 V AC	D0	D2	D2	D0	D2	--	--
48 V AC	H0	H2	H2	H0	H2	--	--
110 V AC	F0	G2	G2	F0	G2	G2	G2
220 V AC	N2	N2	N2	N2	N2	N2	N2
230 V AC	P0	L2	L2	P0	L2	L2	L2
240 V AC	P2	P2	P2	P2	P2	P2	P2

Solenoid coils (for USA and Canada²⁾)

50 Hz	60 Hz						
110 V AC	120 V AC	K6	K6	K6	K6	K6	K6
220 V AC	240 V AC	P6	P6	P6	P6	P6	P6

Solenoid coils (for Japan)

50/60 Hz ³⁾	60 Hz ⁴⁾						
100 V AC	110 V AC	G6	G6	G6	G6	G6	G6
200 V AC	220 V AC	N6	N6	N6	N6	N6	N6
400 V AC	440 V AC	R6	R6	R6	R6	R6	R6

DC operation

12 V DC	A4	--	--	A4	--	--	--
24 V DC	B4	B4	B4	B4	B4	B4	B4
42 V DC	D4	D4	D4	D4	D4	--	--
48 V DC	W4	W4	W4	W4	--	--	--
60 V DC	E4	E4	E4	--	--	--	--
110 V DC	F4	F4	F4	F4	F4	--	--
125 V DC	G4	G4	G4	G4	G4	--	--
220 V DC	M4	M4	M4	M4	M4	--	--
230 V DC	P4	P4	P4	P4	--	--	--

Examples

AC operation	3RT10 34-1AP00	Contactor with screw terminals; with solenoid coil for 50 Hz for rated control supply voltage 230 V AC.
	3RT10 34-1AG20	Contactor with screw terminals; with solenoid coil for 50/60 Hz for rated control supply voltage 110 V AC.
DC operation	3RT10 34-3BB40	Contactor with spring-type terminals; for rated control supply voltage 24 V DC.
	3RT10 34-3BG40	Contactor with spring-type terminals; for rated control supply voltage 125 V DC.

Rated control supply voltage U_s	Contactor type	3RT1. 5.-.A 3RT1. 6.-.A 3RT1. 7.-.A	Rated control supply voltage U_s	Contactor type	3RT1. 5.-.N 3RT1. 6.-.N 3RT1. 7.-.N	3RT1. 5.-.P/Q 3RT1. 6.-.P/Q 3RT1. 7.-.P/Q
$U_{s \min} \dots U_{s \max}^{5)}$	Size	S6, S10, S12	$U_{s \min} \dots U_{s \max}^{5)}$	Size	S6, S10, S12	S6, S10, S12

Sizes S6 to S12

UC operation (AC 40 ... 60 Hz, DC)

Conventional operating mechanisms

23 ... 26 V AC/DC	B3
42 ... 48 V AC/DC	D3
110 ... 127 V AC/DC	F3
200 ... 220 V AC/DC	M3
220 ... 240 V AC/DC	P3
240 ... 277 V AC/DC	U3
380 ... 420 V AC/DC	V3
440 ... 480 V AC/DC	R3
500 ... 550 V AC/DC	S3
575 ... 600 V AC/DC	T3

Solid-state operating mechanism

21 ... 27.3 V AC/DC	B3	--
96 ... 127 V AC/DC	F3	F3
200 ... 277 V AC/DC	P3	P3

¹⁾ Coil operating range:
at 50 Hz: 0.8 to 1.1 × U_s
at 60 Hz: 0.85 to 1.1 × U_s .

²⁾ Coil operating range (sizes S2 and S3):
at 50 Hz and 60 Hz: 0.8 to 1.1 × U_s .

³⁾ Coil operating range (sizes S2 and S3):
at 50 Hz: 0.8 to 1.1 × U_s
at 60 Hz: 0.85 to 1.1 × U_s .

⁴⁾ Coil operating range:
at 60 Hz: 0.8 to 1.1 × U_s .

⁵⁾ Operating range:
0.8 × $U_{s \min}$ to 1.1 × $U_{s \max}$.

Overview

UC operation

The contactors can be operated with AC (40 to 60 Hz) as well as with DC.

Operating mechanism types

Two types of solenoid operation are available:

- Conventional operating mechanism, version 3RT12 ... A
- Solid-state operating mechanism, version 3RT12 ... N

Withdrawable coils

For simple coil replacement, e. g. if the application is replaced, the solenoid coil can be pulled out upwards after the release mechanism has been actuated and can be replaced by any other coil of the same size.

Vacuum interrupters

In contrast with the 3RT10 contactors – the main contacts operate in air under atmospheric conditions – the contact gaps of the 3RT12 vacuum contactors are contained in hermetically enclosed vacuum contact tubes. Neither arcs nor arcing gases are produced. The particular benefit of 3RT12 vacuum contactors, however, is that their electrical endurance is at least twice as long as that of 3RT10 contactors. They are therefore particularly well suited to frequent switching in jogging/mixed operation, e. g. in crane control systems.

Note:

Vacuum contactors are basically unsuitable for switching DC voltage.

Auxiliary contact complement

The contactors can be fitted with up to 8 lateral auxiliary contacts (identical auxiliary switch blocks from S2 to S12). Of these, no more than 4 are permitted to be NC contacts.

Power Contactors for Switching Motors

SIRIUS 3RT12 vacuum contactors, 3-pole, 110 ... 250 kW

Selection and ordering data

UC operation (40 Hz up to 60 Hz, DC)

- Withdrawable coils with integrated surge suppression (varistor)
- Auxiliary and control conductors: Screw terminals
- Main conductors: Busbar connections



3RT12 6.



3RT12 7.

Size	Rated data	AC-1, T _v : 40 °C	Auxiliary contacts, lateral	Rated control supply voltage U _s	DT	Screw terminals	Price € per PU	PU (UNIT, SET, M)	PS*	PG
	AC-2 and AC-3, T _v : Up to 60 °C	Operational current I _e up to	Ratings of induction motors at 50 Hz and	Operational current I _e up to		Order No.				
		1000 V	230 V 400 V 500 V 690 V	1000 V						
		A	kW kW kW kW	A	NO NC V AC/DC					

Conventional operating mechanisms

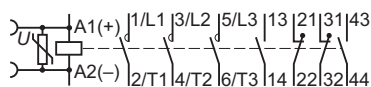

S10	225	55	110	160	200	330	2	2	110 ... 127 220 ... 240	A A	3RT12 64-6AF36 3RT12 64-6AP36	1 1	1 unit 1 unit	41B 41B
	265	75	132	160	250	330	2	2	110 ... 127 220 ... 240	A A	3RT12 65-6AF36 3RT12 65-6AP36	1 1	1 unit 1 unit	41B 41B
S12	300	90	160	200	250	330	2	2	110 ... 127 220 ... 240	A A	3RT12 66-6AF36 3RT12 66-6AP36	1 1	1 unit 1 unit	41B 41B
	400	132	200	250	400	610	2	2	110 ... 127 220 ... 240	A A	3RT12 75-6AF36 3RT12 75-6AP36	1 1	1 unit 1 unit	41B 41B
S12	500	160	250	355	500	610	2	2	110 ... 127 220 ... 240	A A	3RT12 76-6AF36 3RT12 76-6AP36	1 1	1 unit 1 unit	41B 41B

Solid-state operating mechanisms · for 24 V DC PLC output

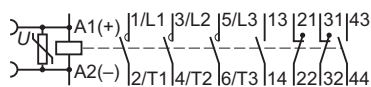

S10	225	55	110	160	200	330	2	2	96 ... 127 200 ... 277	B B	3RT12 64-6NF36 3RT12 64-6NP36	1 1	1 unit 1 unit	41B 41B
	265	75	132	160	250	330	2	2	96 ... 127 200 ... 277	B B	3RT12 65-6NF36 3RT12 65-6NP36	1 1	1 unit 1 unit	41B 41B
S12	300	90	160	200	250	330	2	2	96 ... 127 200 ... 277	B B	3RT12 66-6NF36 3RT12 66-6NP36	1 1	1 unit 1 unit	41B 41B
	400	132	200	250	400	610	2	2	96 ... 127 200 ... 277	B B	3RT12 75-6NF36 3RT12 75-6NP36	1 1	1 unit 1 unit	41B 41B
S12	500	160	250	355	500	610	2	2	96 ... 127 200 ... 277	B B	3RT12 76-6NF36 3RT12 76-6NP36	1 1	1 unit 1 unit	41B 41B

Other voltages according to page 3/26 on request.
 More vacuum contactors 335 kW and 450 kW (type 3TF68/69)
 see [Catalog IC 10 · 2012, Chapter 3](#).
 Accessories see [page 3/39](#).

Power Contactors for Switching Motors

Accessories for 3RT1 contactors

General data

Overview

Snap-on auxiliary switch blocks

Various auxiliary switch blocks can be added to the 3RT1 basic units depending on the application:

Size S00

Terminal designations according to EN 50005 or EN 50012

Size S00 contactors have an auxiliary contact integrated in the basic unit.

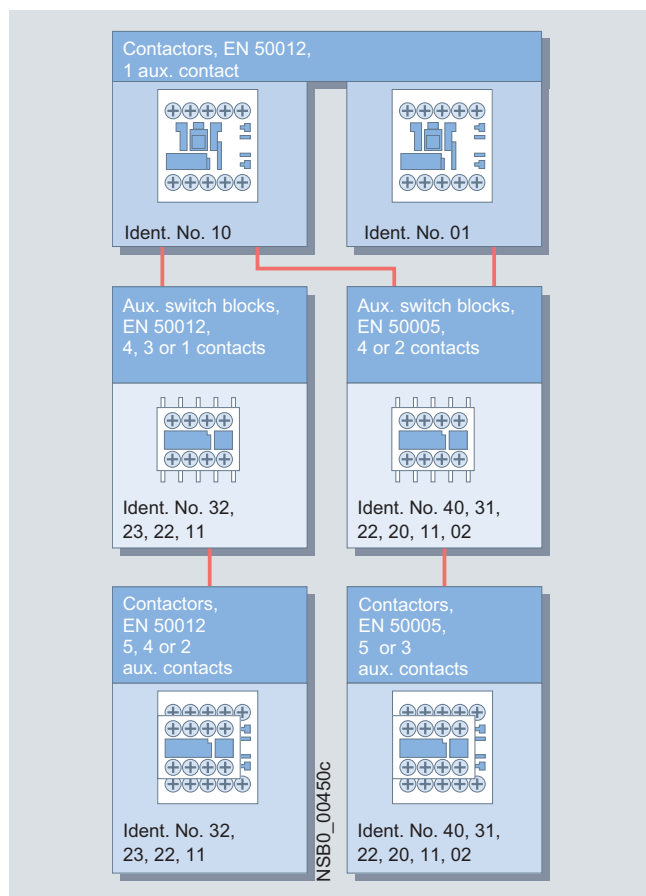

4-pole auxiliary switch blocks 3RT1 (S00).

Contactors with a NO contact as auxiliary contact (screw or spring-type terminals), Ident. No. 10, can be expanded into contactors with 2, 4 or 5 auxiliary contacts according to EN 50012 using auxiliary switch blocks. The Ident. Nos. 11, 22, 23 and 32 on the auxiliary switch blocks apply to the complete contactors. These auxiliary switch blocks cannot be combined with contactors which have a NC contact in the basic unit (Ident. No. 01) as they are coded.

All contactors of size S00 with one auxiliary contact (Ident. Nos. 10 or 01) and the contactors with 4 main contacts can be expanded into contactors with 3 or 5 auxiliary contacts using auxiliary switch blocks with the Ident. Nos. 40 to 02 (in the case of contactors with 4 main contacts: 2 or 4 auxiliary contacts) according to EN 50005. The Ident. Nos. on these auxiliary switch blocks apply only to the attached auxiliary switches.

Single- or 2-pole auxiliary switch blocks with only one connection option from above or below are provided for easy and clearly arranged wiring especially for the installation of network access junctions. These auxiliary switch blocks are offered only with screw terminals.

The solid-state compatible 3RH19 11-1NF. . auxiliary switch blocks for contactors of size S00 include 2 enclosed contacts.

They are suitable in particular for switching small voltages and currents (hard gold-plated contacts) and for operation in dusty atmospheres. The NC auxiliary contacts are not mirror contacts.

All the previously mentioned auxiliary switch variants can be snap-fitted onto the front of the contactor. The auxiliary switch block has a centrally positioned release lever for disassembly.

Sizes S0 to S12

Terminal designations according to EN 50005 or EN 50012

One 4-pole or up to four single-pole auxiliary switch blocks (screw or spring-type connections) can be snapped on. When the contactors are switched on, the NC contacts are opened first and then the NO contacts are closed.

Also available are 2-pole auxiliary switch blocks (screw terminals) for cable entry from above or below in the design of a quad block (feeder auxiliary switch).

If the installation space is limited in depth, 2-pole auxiliary switch blocks (screw or spring-type connections) can be attached laterally (on the left or on the right).

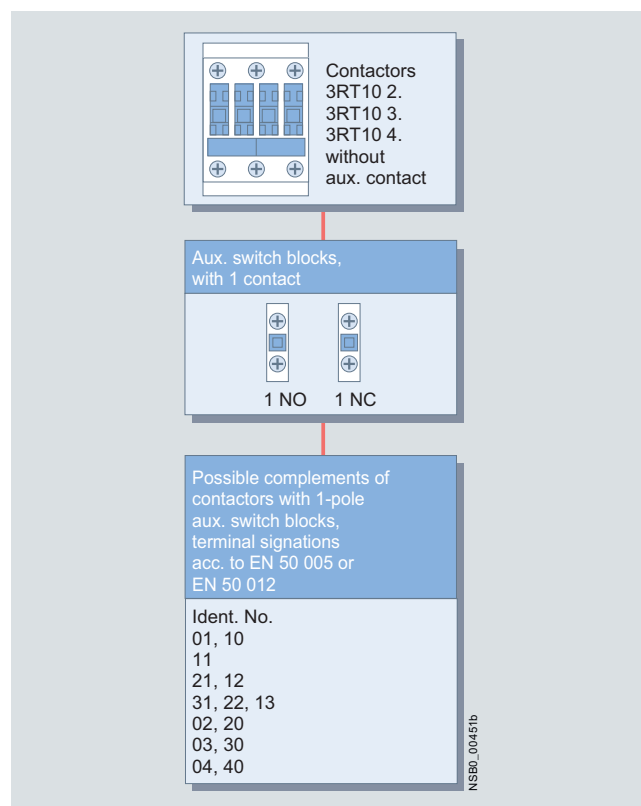

1-pole auxiliary switch blocks for 3RT1 contactors

The terminal designations of the single-pole auxiliary switch blocks are comprised of Ident. Nos. (location identifiers) on the basic unit and of function numbers on the auxiliary switch blocks.

The terminal designations of the individual auxiliary switch blocks correspond to EN 50005 or EN 50012, those of the complete contactors with auxiliary switch block 2 NO + 2 NC correspond to EN 50012.

Power Contactors for Switching Motors

Accessories for 3RT1 contactors

General data

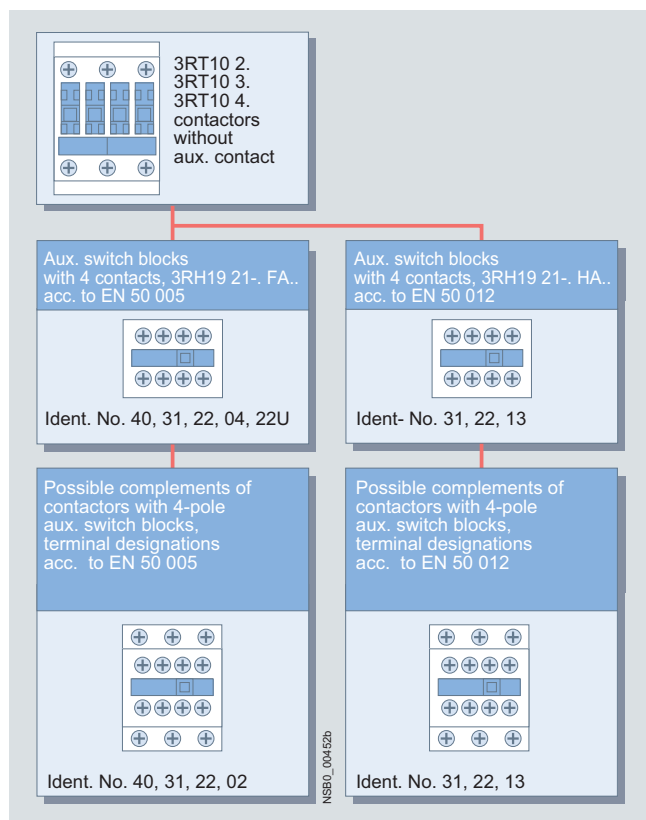

4-pole auxiliary switch blocks for 3RT1 contactors

The auxiliary switch blocks attached to the front can be disassembled with the help of a centrally arranged release lever; the laterally attached auxiliary switch blocks are easy to remove by pressing on the checkered surfaces.

The laterally mountable auxiliary switch blocks according to EN 50012 can be used only when no 4-pole auxiliary switch blocks are snapped onto the front. If single-pole auxiliary switch blocks are used in addition, the location identifiers on the contactor must be noted.

Two enclosed and two standard contacts are available with the 3RH19 21-FE22 solid-state compatible auxiliary switch block, which can be attached to the front. The 3RH19 21-2DE11 laterally mountable auxiliary switch block contains 2 enclosed contacts (1 NO + 1 NC). The enclosed contacts are suitable in particular for switching small voltages and currents (hard gold-plated contacts) and for operation in dusty atmospheres. The NC auxiliary contacts are mirror contacts.

Sizes S0 and S2

A maximum of 4 auxiliary contacts can be attached; the auxiliary switch blocks used can be of any version. For reasons of symmetry, when two 2-pole laterally mountable auxiliary switch blocks are used, one block must be attached on the right and one on the left.

More auxiliary contacts are permissible with size S2 under certain conditions (please ask).

Sizes S3 to S12

A maximum of 8 auxiliary contacts can be attached; please note the following:

- Of these 8 auxiliary contacts, there must be no more than 4 NC contacts
- Ensure the symmetry of laterally mounted auxiliary switch blocks

3RH1 contactor relays

The 3RH1 contactor relays can be expanded by up to four contacts by the addition of snap-on auxiliary switch blocks.

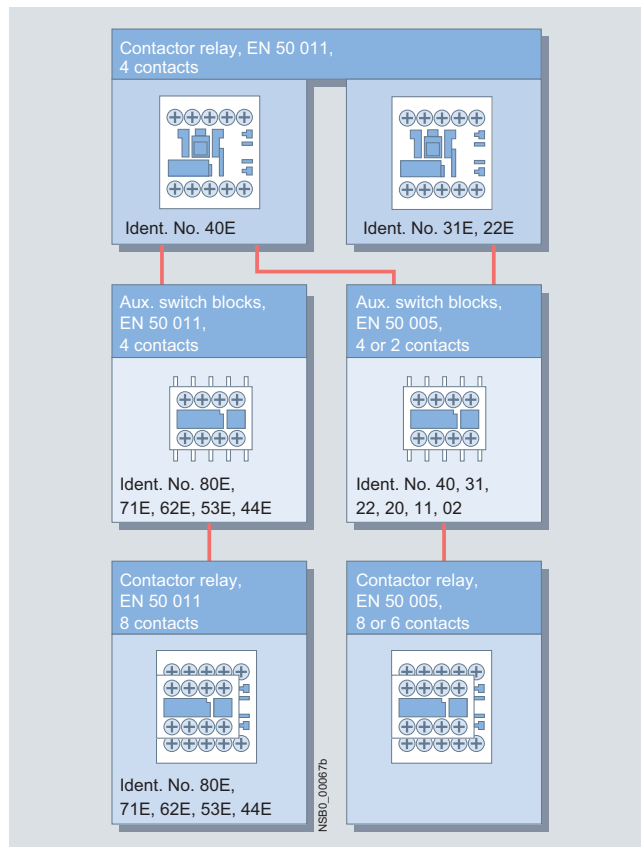

4-pole auxiliary switch blocks for 3RH1 contactor relays

The contactor relays with 4 contacts according to EN 50011, with the Ident. No. 40E, can be extended with 80E to 44E auxiliary switch blocks to obtain contactor relays with 8 contacts according to EN 50011. The Ident. Nos. 80E to 44E on the auxiliary switch blocks apply to the complete contactors. These auxiliary switch blocks (3RH19 11-1GA ..) cannot be combined with contactor relays with Ident. Nos. 31E and 22E; they are coded.

All contactor relays with 4 contacts according to EN 50011, Ident. Nos. 40E to 22E, can be extended with auxiliary switch blocks 40 to 02 to obtain contactor relays with 6 or 8 contacts in accordance with EN 50005. The Ident. Nos. on the auxiliary switch blocks apply only to the attached auxiliary switch blocks.

In addition, fully mounted 3RH12 8-pole contactor relays are available; the mounted 4-pole auxiliary switch block in the 2nd tier is not removable. The terminal designations are according to EN 50011.

These 8-pole versions are built according to special Swiss regulations "SUVA" and are distinguished externally by a red labeling plate.

Power Contactors for Switching Motors

Accessories for 3RT1 contactors

General data

Solid-state time-delay auxiliary switch blocks

The solid-state, time-delay auxiliary switch block is fitted onto the front side of the contactor.

The timer module, which is available in the "ON-DELAY" and "OFF-DELAY" versions, allows time-delayed functions up to 100 s (3 delay ranges). It contains a relay with one NO contact and one NC contact; depending on the version, the relay is switched either after an ON-delay or after an OFF-delay.

The timer module with "WYE-DELTA FUNCTION" is equipped with one delayed and one instantaneous NO contact, with a dead time of 50 ms between the two. The delay time of the NO contact can be adjusted between 1.5 s and 30 s.

Wye-delta function

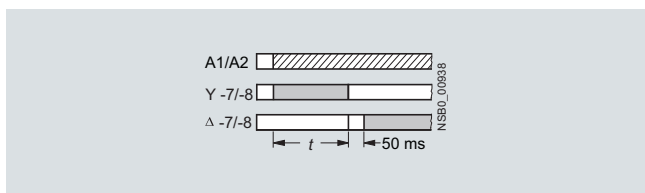

The contactor on which the solid-state time-delay auxiliary switch block is mounted operates without a delay.

Size S00

The timer module is supplied with power directly by plug-in contacts through the coil terminals of the contactor, in parallel with A1/A2. The timing function is activated by closing the contactor on which the auxiliary switch block is mounted. The OFF-delay version operates without an auxiliary voltage; minimum ON period: 200 ms.

A varistor is integrated in the timer module in order to damp opening surges in the contactor coil.

The solid-state time-delay auxiliary switch block cannot be mounted on size S00 coupling contactors.

Sizes S0 to S12

The timer module is supplied with power through two terminals (A1/A2); the time delay of the auxiliary switch block can be activated either by a parallel link to any contactor coil or by any power source.

The OFF-delay version operates without an auxiliary voltage; the minimum ON period is 200 ms.

A single-pole auxiliary switch block can be snapped onto the front of the contactor in addition to the timer module.

The timer module has no integrated components for overvoltage damping.

Solid-state time-delay blocks with semiconductor output

The timer module in the "ON-DELAY" and "OFF-DELAY with auxiliary voltage" versions allows time-delayed functions up to 100 s (3 delay ranges). Contactors fitted with a timing relay block close or open after a delay according to the set time.

The timing relays are suitable for both AC and DC operation.

A varistor is integrated in the timer module in order to damp opening surges in the contactor coil.

Size S00

The version for size S00 contactors is fitted onto the front of the contactor (with the control supply voltage switched off) and then slid into its latched position; at the same time, the timing relay is connected by means of plug-in contacts to coil terminals A1 and A2 of the contactor. Any contactor coil terminals which are not required are sealed off by means of covers on the enclosure of the timing relay block, to prevent them from being connected inadvertently.

The solid-state, timing relay block cannot be mounted on size S00 coupling contactors.

Sizes S0 to S3

The timing relay block for size S0 to S3 contactors is plugged into coil terminals A1 and A2 on top of each contactor; the timing relay is connected both electrically and mechanically by means of pins.

Configuration

The ON-delay variant of the timing relay is connected in series with the contactor coil; terminal A1 of this coil must not be connected.

With the OFF-delay variant of the timing relay, the contactor coil is contacted directly through the relay; terminals A1 and A2 of the contactor coil must not be connected.

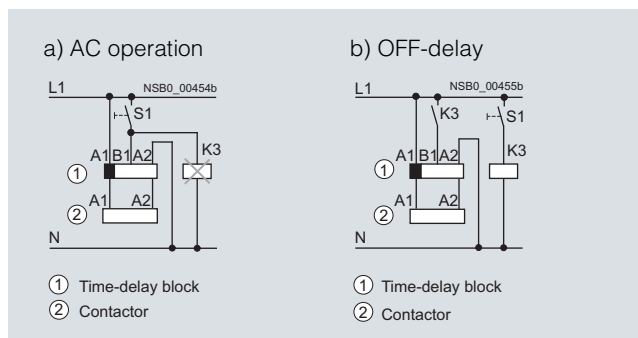

The activation of loads parallel to the start input is not permissible when using AC control voltage (see (a) in the circuit diagram).

The 3RT19 26-2D... OFF-delay timing relay blocks have a zero potential start input B1. This means that if there is a parallel load on terminal B1, activation can be simulated with AC voltage. In this case, the additional load (e. g. contactor K3) must be wired (see (b) in the drawing).

Power Contactors for Switching Motors

Accessories for 3RT1 contactors

General data

OFF-delay device for size S00 to S3 contactors

AC and DC operation

IEC 60947, EN 60947

For screw and snap-on mounting onto TH 35 standard mounting rail. The OFF-delay devices have screw terminals.

The OFF-delay device prevents a contactor from dropping out unintentionally when there is a short-time voltage dip or voltage failure. It supplies a downstream, DC-operated contactor with the necessary energy during a voltage dip, ensuring that the contactor does not trip. The 3RT19 16 OFF-delay devices are specifically designed for operation with the 3RT contactors and 3RH contactor relays of the SIRIUS series.

The OFF-delay device operates without external voltage on a capacitive basis, and can be energized with either AC or DC (24 V version only for DC operation). Voltage matching, which is only necessary with AC operation, is performed using a rectifier bridge.

A contactor opens after a delay when the capacitors of the solenoid coil, built into the OFF-delay device, are switched in parallel. In the event of voltage failures, the capacitors are discharged via the solenoid coil and thereby delay the opening of the contactor.

If the command devices are upstream of the OFF-delay device in the circuit, the OFF-delay takes effect with every opening operation. If the opening operation is downstream of the OFF-delay device, an OFF-delay only applies in the event of failure of the mains voltage.

Operation

In the case of the versions for rated control supply voltages of 110 V and 230 V, either AC voltage or DC voltage can be applied on the line side, whereas the variant for 24 V is designed for DC operation only.

A DC-operated contactor is connected to the output in accordance with the input voltage that is applied.

The mean value of the OFF-delay is approximately 1.5 times the specified minimum time.

Surge suppressors

- Without LED (also for spring-type terminals)
Sizes S00, S0, S2, S3, S6 to S12
- With LED (also for spring-type terminals)
Size S00

All 3RT1 contactors and 3RH1 contactor relays can be retrofitted with RC elements or varistors for damping opening surges in the coil. Diodes or diode assemblies (comprising noise suppression diodes and Zener diodes for short break times) can be used.

The surge suppressors are plugged onto the front of size S00 contactors. Space is provided for them next to a snap-on auxiliary switch block.

With all size S0 to S3 contactors, varistors, RC elements and diode assemblies can be plugged on directly at the coil terminals, either on the top or underneath.

The plug-in direction of the diodes and diode assemblies is determined by a coding device.

Coupling contactors are supplied either without overvoltage damping or with a varistor or diode connected as standard, according to the version.

Note:

The OFF-delay of the NO contact and the ON-delay of the NC contact are increased if the contactor coils are attenuated against voltage peaks (noise suppression diode 6 to 10 times; diode assembly 2 to 6 times, varistor +2 to 5 ms).

Additional load modules

The module is available for size S00 and is plugged onto the front of the contactors with and without auxiliary switch block.

Coupling links for mounting on contactors of sizes S0 to S3

DC operation

IEC 60947, EN 60947

The coupling link is suitable for use in any climate. It is finger-safe according to EN 50274. The terminal designations comply with EN 50005.

System-compatible operation with 24 V DC, operating range 17 to 30 V.

Low power consumption in conformity with the technical specifications of the solid-state systems. An LED indicates the switching state.

Surge suppression

The 3RH19 24-1GP11 coupling link has an integrated surge suppressor (varistor) for the contactor coil being switched.

Mounting

The 3RH19 24-1GP11 coupling link is mounted directly on the contactor coil.

Solder pin adapters

The solder pin adapters for the size S00 contactors are available in two versions:

- Solder pin adapters for contactors with one integrated auxiliary contact
- Solder pin adapters for contactors with mounted 4-pole auxiliary switch block

Screw adapters

Plug-on adapters improve the accessibility of the screw connection for size S0 contactors. As a result it is possible to position the screwdriver vertically even when using insulated screwdrivers or power screwdrivers.

Optionally the adapters can be rotated through 90° before mounting.

Sealable covers for sizes S2 to S12

When contactors and contactor relays are used in safety-oriented applications, it must be ensured that it is impossible to operate the contactors manually.

For SIRIUS contactors there are sealable covers available for this purpose as accessories; these prevent accidental manual operation. These are transparent molded-plastic caps with a bracket that enables the contactor to be sealed.

Power Contactors for Switching Motors

Accessories for 3RT1 contactors

General data

EMC suppression module, three-phase (size S00)



What is known as a counter-e.m.f. (electromotive force) is produced when motors or various inductive loads are turned off. Voltage peaks of up to 4000 V may occur as a result, with a frequency spectrum from 1 kHz to 10 MHz and a rate of voltage variation from 0.1 to 20 V/ns.

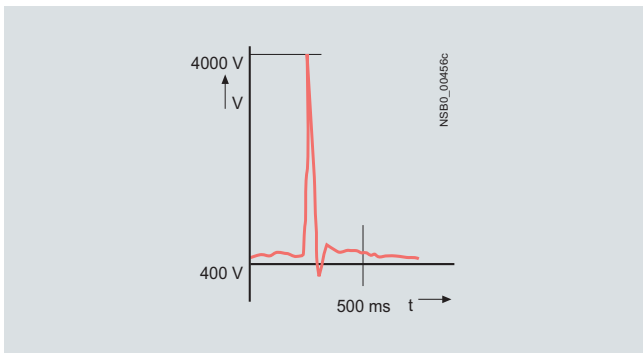

Capacitive input to various analog and digital signals makes it necessary to suppress interference in the load circuit.

Reducing contact arcing

The connection between the main current path and the EMC suppression module enables contact arcing, which is responsible for contact erosion and the majority of clicking noises, to be reduced; this in turn is conducive to an electromagnetically compatible design.

Higher operational reliability

Since the EMC suppression module achieves a significant reduction in radio-frequency components and the voltage level in three phases, the contact endurance is also improved considerably. This makes an important contribution towards enhancing the reliability and availability of the system as a whole.

Dispensing with fine graduations

There is no need for fine graduations within each performance class, as smaller motors inherently have a higher inductance, so that one solution for all fixed-speed operating mechanisms up to 5.5 kW is adequate.

Two electrical versions are available:

- The advantages of the RC circuit lie mainly in the reduction in the rate of rise and in its RF damping ability. The selected values ensure effective interference suppression over a wide range.

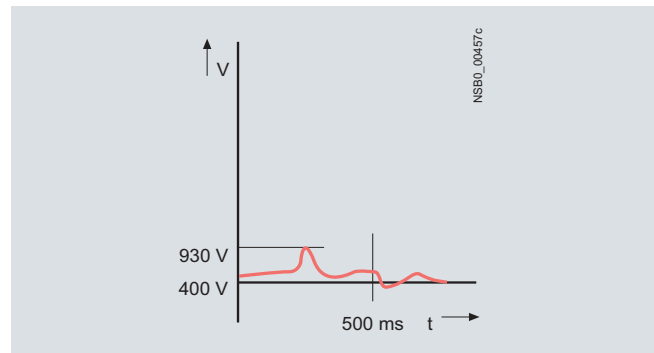

- The varistor circuit can absorb a high energy level and can also be used for frequencies ranging from 10 to 400 Hz (closed-loop controlled operating mechanisms). There is no limiting below the knee-point voltage, however.

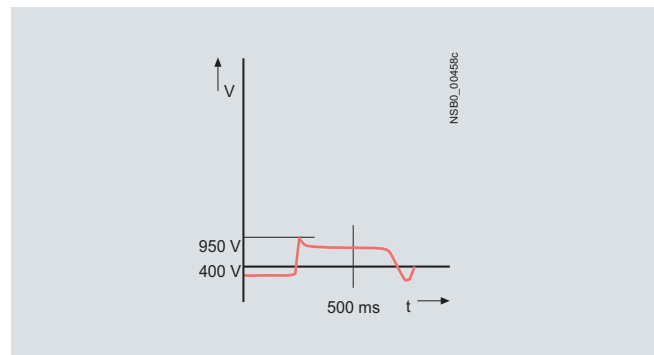



Power Contactors for Switching Motors

Accessories for 3RT1 contactors

General data

Circuit diagrams

Function	Function chart	Circuit diagrams
----------	----------------	------------------

-  Timing relay energized
-  Contact closed
-  Contact open

Solid-state time-delay auxiliary switch blocks

With ON-delay
1 NO + 1 NC

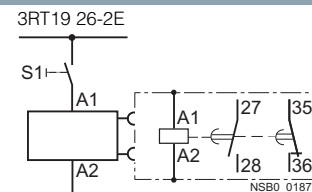
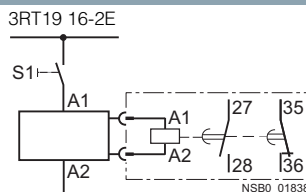
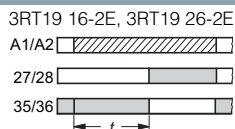

OFF-delay
without auxiliary voltage
1 NO + 1 NC

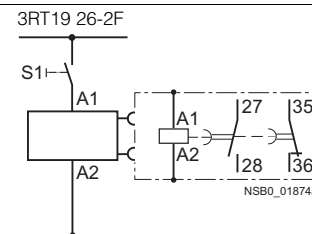
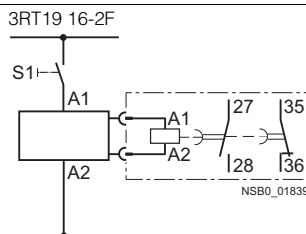
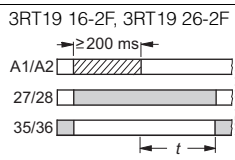

OFF-delay,
with auxiliary voltage
1 CO contact

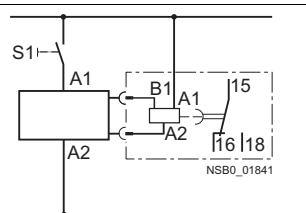
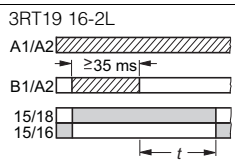

Wye-delta function
1 NO delayed,
1 NO instantaneous,
dead time 50 ms

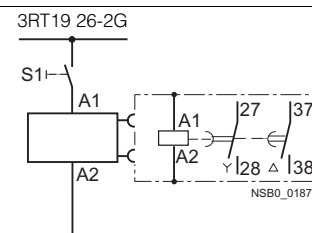
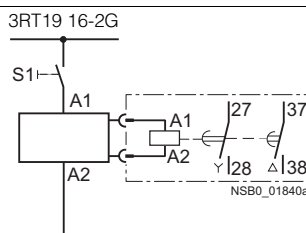
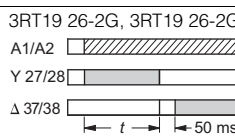

Solid-state time-delay blocks

ON-delay,
two-wire version
1 NO contact (semiconductor output)

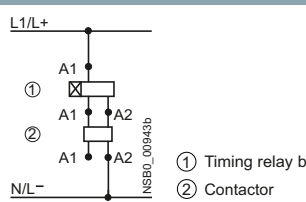
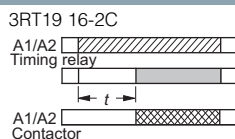

ON-delay,
two-wire version
1 NO contact (semiconductor output)

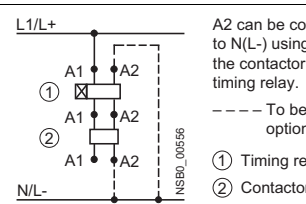
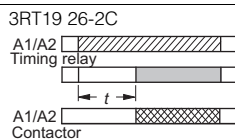

OFF-delay,
with auxiliary voltage
1 NO contact (semiconductor output)

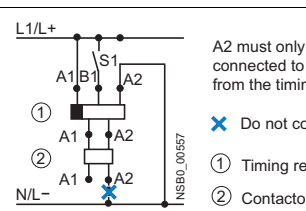
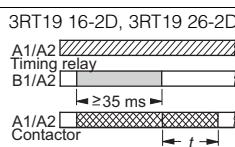

Power Contactors for Switching Motors

Accessories for 3RT1 contactors

Auxiliary switches

Selection and ordering data

PU (UNIT, SET, M) = 1
 PS* = 1 UNIT
 PG = 41B



3RH19 11-1HA..

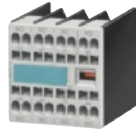

3RH19 11-2HA..



3RH19 21-1HA..

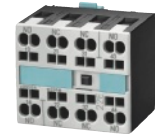

3RH19 21-2HA..

For contactors: Auxiliary contacts

DT

Screw terminals



DT

Spring-type terminals



Ident. No.

Version

Order No.

Price €
per PU

Order No.

Price €
per PU

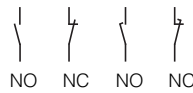

Type

NO NC NO NC

Auxiliary switch blocks for snapping onto the front according to EN 50012

Size S00

1-, 2- and 4-pole auxiliary switch blocks for assembling contactors with 2, 4 and 5 auxiliary contacts

3RT1. 1,
Ident. No. 10

Ident. No.	NO	NC	NO	NC	Diagram
01 → 11	--	1	--	--	
12 → 22	1	2	--	--	
13 → 23	1	3	--	--	
22 → 32	2	2	--	--	

▶ 3RH19 11-1HA01

▶ 3RH19 11-2HA01

▶ 3RH1911-1HA12

▶ 3RH19 11-2HA12

▶ 3RH1911-1HA13

▶ 3RH19 11-2HA13

▶ 3RH19 11-1HA22

▶ 3RH19 11-2HA22

Sizes S0 to S3¹⁾

4-pole auxiliary switch blocks

3RT1. 2,
3RT1. 3,
3RT1. 4

Ident. No.	NO	NC	NO	NC	Diagram
31	3	1	--	--	
22	2	2	--	--	
13	1	3	--	--	

▶ 3RH19 21-1HA31

▶ 3RH19 21-2HA31

▶ 3RH19 21-1HA22

▶ 3RH19 21-2HA22

▶ 3RH19 21-1HA13

▶ 3RH19 21-2HA13

Sizes S0 to S12²⁾

4-pole auxiliary switch blocks

3RT1. 3 ...
3RT1. 7

Ident. No.	NO	NC	NO	NC	Diagram
22	2	2	--	--	

B ▶ 3RH19 21-1XA22-0MA0

D ▶ 3RH19 21-2XA22-0MA0

Multi-unit packing and reusable packaging see Catalog IC 10 · 2012, "Appendix" → "Ordering Notes", number of units on request.

¹⁾ Exception: 3RT16.

²⁾ Exception: 3RT12, 3RT16.

Power Contactors for Switching Motors

Accessories for 3RT1 contactors

Auxiliary switches

PU (UNIT, SET, M) = 1
 PS* = 1 UNIT
 PG = 41B



3RH19 11-1LA..



3RH19 11-1FA..



3RH19 11-2FA..

For contactors		Auxiliary contacts	DT	Screw terminals	DT	Spring-type terminals	
Ident. No.	Version			Order No.	Price € per PU	Order No.	Price € per PU
Type	NO NC NO NC	 					

Auxiliary switch blocks for snapping onto the front according to EN 50005

Size S00

2- and 4-pole auxiliary switch blocks for assembling contactors with 3 and 5 auxiliary contacts

3RT1. 1, 3RH11, 3RH14	20	11	02	11U	40	31	22	22U	11, 11U	3RH19 11-1FA20	3RH19 11-2FA20
	2 0 -- --	1 2 -- --	-- 2 -- --	-- -- 1 1	4 -- -- --	3 1 -- --	2 2 -- --	-- -- 2 2	1 1 1 1		
										3RH19 11-1FA11	3RH19 11-2FA11
										3RH19 11-1FA02	3RH19 11-2FA02
										3RH19 11-1FB11	A 3RH19 11-2FB11
										3RH19 11-1FA40	3RH19 11-2FA40
										3RH19 11-1FA31	3RH19 11-2FA31
										3RH19 11-1FA22	3RH19 11-2FA22
										3RH19 11-1FC22	3RH19 11-2FC22
										3RH19 11-1FB22	B 3RH19 11-2FB22

1- and 2-pole auxiliary switch blocks, terminals on one side

• Cable entry from above

3RT1. 1, 3RH11, 3RH14	--	--	--	--	3RH19 11-1AA10	--
	1 -- -- --	-- 1	1 1	2 -		
					3RH19 11-1AA01	--
					3RH19 11-1LA11	--
					3RH19 11-1LA20	--

Multi-unit packing and reusable packaging see [Catalog IC 10 · 2012, "Appendix" → "Ordering Notes"](#), number of units on req.

Power Contactors for Switching Motors

Accessories for 3RT1 contactors

Auxiliary switches

PU (UNIT, SET, M) = 1
 PS* = 1 UNIT
 PG = 41B



3RH19 21-1FA..

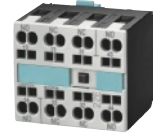

3RH19 21-2FA..

For contactors	Auxiliary contacts	DT	Screw terminals		DT	Spring-type terminals
Ident. No.	Version		Order No.	Price € per PU	Order No.	Price € per PU
Type	NO NC NO NC					

Auxiliary switch blocks for snapping onto the front according to EN 50005

Size S00

1- and 2-pole auxiliary switch blocks, terminals on one side
 • Cable entry from below

3RT1. 1, 3RH11, 3RH14	--	1	--	--		▶	3RH19 11-1BA10	--
	--	--	1	--		▶	3RH19 11-1BA01	--
	--	1	1	--		▶	3RH19 11-1MA11	--
	--	2	--	--		▶	3RH19 11-1MA20	--

Sizes S0 to S3¹⁾

4-pole auxiliary switch blocks

3RT1. 3, 3RT1. 4	40	4	--	--	--		▶	3RH19 21-1FA40	▶	3RH19 21-2FA40
	31	3	1	--	--		▶	3RH19 21-1FA31	▶	3RH19 21-2FA31
	22	2	2	--	--		▶	3RH19 21-1FA22	▶	3RH19 21-2FA22
	04	--	4	--	--		▶	3RH19 21-1FA04	A	3RH19 21-2FA04
	22 U	--	--	2	2		▶	3RH19 21-1FC22	A	3RH19 21-2FC22

Multi-unit packing and reusable packaging see [Catalog IC 10 · 2012, "Appendix" → "Ordering Notes"](#), number of units on request.

¹⁾ Exception: 3RT16.

Power Contactors for Switching Motors

Accessories for 3RT1 contactors

Auxiliary switches

PU (UNIT, SET, M) = 1
 PS* = 1 UNIT
 PG = 41B



3RH19 21-1LA..



3RH19 21-1MA..



3RH19 21-1C..



3RH19 21-2C..

For contactors: Auxiliary contacts		DT	Screw terminals		DT	Spring-type terminals	
Ident. No.	Version		Order No.	Price € per PU	Order No.	Price € per PU	
	NO NC NO NC						

Auxiliary switch blocks for snapping onto the front according to EN 50005

Sizes S0 to S3¹⁾

2-pole auxiliary switch blocks, terminals on one side
 • Cable entry from above

3RT1. 3, 3RT1. 4	11	1	1	--	--		▶	3RH19 21-1LA11	--
	20	2	--	--	--		▶	3RH19 21-1LA20	--
	02	--	2	--	--		▶	3RH19 21-1LA02	--

• Cable entry from below

3RT1. 3, 3RT1. 4	11	1	1	--	--		▶	3RH19 21-1MA11	--
	20	2	--	--	--		▶	3RH19 21-1MA20	--
	02	--	2	--	--		▶	3RH19 21-1MA02	--

Sizes S0 to S12²⁾

1-pole auxiliary switch blocks according to EN 50005 and EN 50012

3RT1. 3 ... 3RT1. 7	10	1	--	--	--		▶	3RH19 21-1CA10	▶	3RH19 21-2CA10
	01	--	1	--	--		▶	3RH19 21-1CA01	▶	3RH19 21-2CA01
	10	--	--	1	--		▶	3RH19 21-1CD10	--	--
	01	--	--	--	1		▶	3RH19 21-1CD01	--	--

¹⁾ Exception: 3RT16.

²⁾ Exception: 3RT12, 3RT16

Power Contactors for Switching Motors

Accessories for 3RT1 contactors

Auxiliary switches

PU (UNIT, SET, M) = 1
 PS* = 1 UNIT
 PG = 41B



3RH19 21-1.A11



3RH19 21-2.A11

For contactors	Auxiliary contacts	DT	Screw terminals	DT	Spring-type terminals	
	Version		Order No.	Price € per PU	Order No.	Price € per PU
Type	NO NC					

Laterally mountable auxiliary switch blocks according to EN 50012

Mounting:	Left	Right		
Sizes S0 to S3				
First laterally mountable auxiliary switch block, 2-pole				
3RT1 . 3, 3RT1 . 4	1 1			▶ 3RH19 21-1DA11 ▶ 3RH19 21-2DA11

Mounting:	Left	Right		
Sizes S3 ... S12				
Second laterally mountable auxiliary switch block, 2-pole				
3RT1 . 4 ... 3RT1 . 7	1 1			▶ 3RH19 21-1JA11 ▶ 3RH19 21-2JA11

Laterally mountable auxiliary switch blocks according to EN 50005

Mounting:	Left	Right		
Sizes S3 to S12				
First laterally mountable auxiliary switch block, 2-pole				
3RT1 . 3 ... 3RT1 . 7	2 --			▶ 3RH19 21-1EA20 ▶ 3RH19 21-2EA20
	1 1			▶ 3RH19 21-1EA11 ▶ --
	-- 2			▶ 3RH19 21-1EA02 ▶ 3RH19 21-2EA02

Mounting:	Left	Right		
Sizes S3 to S12				
Second laterally mountable auxiliary switch block, 2-pole				
3RT1 . 4 ... 3RT1 . 7	2 --			▶ 3RH19 21-1KA20 D ▶ 3RH19 21-2KA20
	1 1			▶ 3RH19 21-1KA11 ▶ --
	-- 2			▶ 3RH19 21-1KA02 D ▶ 3RH19 21-2KA02

Power Contactors for Switching Motors

Accessories for 3RT1 contactors

Auxiliary switches

PU (UNIT, SET, M) = 1
 PS* = 1 unit
 PG = 41B



3RH19 21-2DE11,
3RH19 21-2JE11



3RH19 11-1NF.



3RH19 21-1FE22

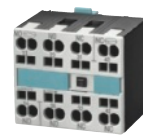

3RH19 21-2FE22

For contactors	Contacts	DT	Screw terminals	DT	Spring-type terminals	
	Version		Order No.	Price € per PU	Order No.	Price € per PU
Type	NO NO ¹⁾ NC ¹⁾ NC					

Solid-state compatible auxiliary switch blocks

- For operation in dusty atmospheres
- For solid-state circuits with rated operational currents I_{th} /AC-14 and DC-13 of 1 ... 300 mA at 3 ... 60 V
- Hard gold-plated contacts
- Mirror contacts acc. to EN 60947-4-1, Appendix F

Auxiliary switch blocks for snapping onto the front according to EN 50005

Size S00

3RT1. 1., 3RH11, 3RH14	1	--	--	1		▶	3RH19 11-1NF11	A	3RH19 11-2NF11
	2	--	--	--		▶	3RH19 11-1NF20	A	3RH19 11-2NF20
	--	--	--	2		A	3RH19 11-1NF02	A	3RH19 11-2NF02

Sizes S0 to S3

3RT1. 3 ... 3RT1. 7	1	1	1	1		▶	3RH19 21-1FE22	B	3RH19 21-2FE22
------------------------	---	---	---	---	--	---	-----------------------	---	-----------------------

Laterally mountable auxiliary switch blocks according to EN 50012

Sizes S0 to S12

	Mounting: Left		Right				
	First laterally mountable auxiliary switch block, 2-pole						
3RT1. 3 ... 3RT1. 7	1	--	--	1		▶	3RH19 21-2DE11

Sizes S3 to S12

	Left		Right				
	Second laterally mountable auxiliary switch block, 2-pole						
3RT1. 4 ... 3RT1. 7	1	--	--			▶	3RH19 21-2JE11

¹⁾ 1 NO + 1 NC standard auxiliary switches:
 See descriptions on page 3/29.

Power Contactors for Switching Motors

Accessories for 3RT1 contactors

Solid-state time-delay auxiliary switch blocks,
timing relay blocks and other time-delay blocks

Selection and ordering data

For contactors	Auxiliary contacts	Rated control supply voltage U_s ¹⁾	Time setting range t	DT	Screw terminals	⊕	PU (UNIT, SET, M)	PS*	PG
Type		V	s		Order No.	Price € per PU			

Solid-state time-delay auxiliary switch blocks for snapping onto the front, terminal designations according to DIN 46199-5

Size S00



3RT19 16-2...

For contactors	Auxiliary contacts	Rated control supply voltage U_s ¹⁾	Time setting range t	DT	Screw terminals	⊕	PU (UNIT, SET, M)	PS*	PG	
3RT1. 1, 3RH11 ²⁾ 3RH14	With ON-delay ³⁾ 1 NO + 1 NC	24 AC/DC	0,05 ... 1	▶	3RT19 16-2EJ11		1	1 unit	41H	
			0,5 ... 10	▶	3RT19 16-2EJ21		1	1 unit	41H	
			5 ... 100	B	3RT19 16-2EJ31		1	1 unit	41H	
		100 ... 127 AC	0,05 ... 1	C	3RT19 16-2EC11		1	1 unit	41H	
			0,5 ... 10	▶	3RT19 16-2EC21		1	1 unit	41H	
			5 ... 100	▶	3RT19 16-2EC31		1	1 unit	41H	
	200 ... 240 AC	0,05 ... 1	D	3RT19 16-2ED11		1	1 unit	41H		
		0,5 ... 10	▶	3RT19 16-2ED21		1	1 unit	41H		
		5 ... 100	▶	3RT19 16-2ED31		1	1 unit	41H		
	3RT1. 1, 3RH11 ²⁾ 3RH14	OFF-delay without auxiliary voltage ³⁾⁴⁾ 1 NO + 1 NC	24 AC/DC	0,05 ... 1	▶	3RT19 16-2FJ11		1	1 unit	41H
				0,5 ... 10	▶	3RT19 16-2FJ21		1	1 unit	41H
				5 ... 100	▶	3RT19 16-2FJ31		1	1 unit	41H
100 ... 127 AC/DC			0,05 ... 1	C	3RT19 16-2FK11		1	1 unit	41H	
			0,5 ... 10	▶	3RT19 16-2FK21		1	1 unit	41H	
			5 ... 100	B	3RT19 16-2FK31		1	1 unit	41H	
200 ... 240 AC/DC		0,05 ... 1	D	3RT19 16-2FL11		1	1 unit	41H		
		0,5 ... 10	▶	3RT19 16-2FL21		1	1 unit	41H		
		5 ... 100	▶	3RT19 16-2FL31		1	1 unit	41H		
3RT10 1 3RH11 ²⁾		OFF-delay with auxiliary voltage (varistor integrated) 1 CO	24 AC/DC	0,5 ... 10	B	3RT19 16-2LJ21		1	1 unit	41H
			100 ... 127 AC	0,5 ... 10	B	3RT19 16-2LC21		1	1 unit	41H
			200 ... 240 AC	0,5 ... 10	C	3RT19 16-2LD21		1	1 unit	41H
3RT10 1 ²⁾	Wye-delta function (varistor integrated) ³⁾ 1 NO delayed + 1 NO instantaneous, dead time 50 ms	24 AC/DC	1,5 ... 30	▶	3RT19 16-2GJ51		1	1 unit	41H	
		100 ... 127 AC	1,5 ... 30	D	3RT19 16-2GC51		1	1 unit	41H	
		200 ... 240 AC	1,5 ... 30	▶	3RT19 16-2GD51		1	1 unit	41H	

Sizes S0 to S12



3RT19 26-2...

For contactors	Auxiliary contacts	Rated control supply voltage U_s ¹⁾	Time setting range t	DT	Screw terminals	⊕	PU (UNIT, SET, M)	PS*	PG	
3RT10, 3RT13, 3RT14, 3RT15	With ON-delay ⁵⁾ 1 NO + 1 NC	24 AC/DC	0,05 ... 1	D	3RT19 26-2EJ11		1	1 unit	41H	
			0,5 ... 10	▶	3RT19 26-2EJ21		1	1 unit	41H	
			5 ... 100	A	3RT19 26-2EJ31		1	1 unit	41H	
		100 ... 127 AC	0,05 ... 1	C	3RT19 26-2EC11		1	1 unit	41H	
			0,5 ... 10	▶	3RT19 26-2EC21		1	1 unit	41H	
			5 ... 100	D	3RT19 26-2EC31		1	1 unit	41H	
	200 ... 240 AC	0,05 ... 1	D	3RT19 26-2ED11		1	1 unit	41H		
		0,5 ... 10	▶	3RT19 26-2ED21		1	1 unit	41H		
		5 ... 100	B	3RT19 26-2ED31		1	1 unit	41H		
	3RT10, 3RT13, 3RT14, 3RT15	OFF-delay without auxiliary voltage ⁴⁾⁵⁾ 1 NO + 1 NC	24 AC/DC	0,05 ... 1	▶	3RT19 26-2FJ11		1	1 unit	41H
				0,5 ... 10	▶	3RT19 26-2FJ21		1	1 unit	41H
				5 ... 100	▶	3RT19 26-2FJ31		1	1 unit	41H
100 ... 127 AC/DC			0,05 ... 1	D	3RT19 26-2FK11		1	1 unit	41H	
			0,5 ... 10	▶	3RT19 26-2FK21		1	1 unit	41H	
			5 ... 100	C	3RT19 26-2FK31		1	1 unit	41H	
200 ... 240 AC/DC		0,05 ... 1	D	3RT19 26-2FL11		1	1 unit	41H		
		0,5 ... 10	A	3RT19 26-2FL21		1	1 unit	41H		
		5 ... 100	A	3RT19 26-2FL31		1	1 unit	41H		
3RT10, 3RT13, 3RT14, 3RT15		Wye-delta function (varistor integrated) ⁵⁾ 1 NO delayed + 1 NO instantaneous, dead time 50 ms	24 AC/DC	1,5 ... 30	▶	3RT19 26-2GJ51		1	1 unit	41H
			100 ... 127 AC	1,5 ... 30	▶	3RT19 26-2GC51		1	1 unit	41H
			200 ... 240 AC	1,5 ... 30	▶	3RT19 26-2GD51		1	1 unit	41H

Function diagrams and circuit diagrams see page 3/34.













- The AC voltages are valid for 50 and 60 Hz.
- Cannot be fitted onto 3RT1 and 3RH11 coupling contactors.
- The terminals for the control supply voltage are connected to the contactor by the integrated spring contacts of the solid-state time auxiliary switch above it when this switch is mounted.
- Setting of output contacts in as-supplied state not defined (bistable relay). Application of the control supply voltage once results in contact change-over to the correct setting.

- Terminals A1 and A2 for the control supply voltage of the solid-state time-delay auxiliary switch must be connected to the associated contactor by means of connecting cables.

Power Contactors for Switching Motors

Accessories for 3RT1 contactors

Solid-state time-delay auxiliary switch blocks, timing relay blocks and other time-delay blocks

For contactors	Rated control supply voltage $U_s^{(1)}$	Time setting range t	DT	Screw terminals 	PU (UNIT, SET, M)	PS*	PG	
Type	s		Order No.	Price € per PU				
Solid-state time-delay blocks with semiconductor output								
Size S00								
For mounting onto the front of contactors								
• ON-delay (varistor integrated)								
 3RT19 16-2C...	3RT1. 1, 3RH11 ¹⁾	24 ... 66 AC/DC	0,05 ... 1	B	3RT19 16-2CG11	1	1 unit 41H	
	3RH14	90 ... 240 AC/DC	0,5 ... 10	▶	3RT19 16-2CG21	1	1 unit 41H	
			5 ... 100	B	3RT19 16-2CG31	1	1 unit 41H	
 3RT19 16-2D...	3RT1. 1, 3RH11 ¹⁾ 3RH14	90 ... 240 AC/DC	0,05 ... 1	D	3RT19 16-2CH11	1	1 unit 41H	
			0,5 ... 10	▶	3RT19 16-2CH21	1	1 unit 41H	
			5 ... 100	▶	3RT19 16-2CH31	1	1 unit 41H	
• OFF-delay with auxiliary voltage (varistor integrated)								
 3RT19 16-2D...	3RT1. 1, 3RH11 ¹⁾ 3RH14	24 ... 66 AC/DC	0,05 ... 1	C	3RT19 16-2DG11	1	1 unit 41H	
			0,5 ... 10	B	3RT19 16-2DG21	1	1 unit 41H	
			5 ... 100	B	3RT19 16-2DG31	1	1 unit 41H	
 3RT19 16-2D...	90 ... 240 AC/DC	0,05 ... 1	D	3RT19 16-2DH11	1	1 unit 41H		
		0,5 ... 10	▶	3RT19 16-2DH21	1	1 unit 41H		
		5 ... 100	B	3RT19 16-2DH31	1	1 unit 41H		
Sizes S0 to S3								
For mounting onto top-lying coil terminals, (only for contactors with screw terminals)								
• ON-delay (varistor integrated)								
 3RT19 26-2C...	3RT10 2, 3RT10 3, 3RT10 4 ²⁾ , 3RT13, 3RT15	24 ... 66 AC/DC	0,05 ... 1	D	3RT19 26-2CG11	1	1 unit 41H	
			0,5 ... 10	B	3RT19 26-2CG21	1	1 unit 41H	
			5 ... 100	D	3RT19 26-2CG31	1	1 unit 41H	
 3RT19 26-2C...	90 ... 240 AC/DC	0,05 ... 1	▶	3RT19 26-2CH11	1	1 unit 41H		
		0,5 ... 10	▶	3RT19 26-2CH21	1	1 unit 41H		
		5 ... 100	▶	3RT19 26-2CH31	1	1 unit 41H		
• OFF-delay with auxiliary voltage (varistor integrated)								
 3RT19 26-2D...	3RT10 2, 3RT10 3, 3RT10 4 ²⁾ , 3RT13, 3RT15	24 ... 66 AC/DC	0,05 ... 1	D	3RT19 26-2DG11	1	1 unit 41H	
			0,5 ... 10	D	3RT19 26-2DG21	1	1 unit 41H	
			5 ... 100	D	3RT19 26-2DG31	1	1 unit 41H	
 3RT19 26-2D...	90 ... 240 AC/DC	0,05 ... 1	C	3RT19 26-2DH11	1	1 unit 41H		
		0,5 ... 10	D	3RT19 26-2DH21	1	1 unit 41H		
		5 ... 100	C	3RT19 26-2DH31	1	1 unit 41H		
OFF-delay devices								
Sizes S00 to S3								
 3RT19 16-2B.01	3RT1. 1, 3RT1. 2, 3RH1. ...-1BF40	110 AC/DC	S00: 130 non-adjustable	D	3RT19 16-2BK01	1	1 unit 41H	
			S0: 100 non-adjustable					
			220/230 AC/DC	S00: 600 non-adjustable	D	3RT19 16-2BL01	1	1 unit 41H
S0: 400 non-adjustable								
24 DC	S00: 250 non-adjustable	▶		3RT19 16-2BE01	1	1 unit 41H		
	S0: 150 non-adjustable							
	S2: 90 non-adjustable							
S3: 70 non-adjustable								
Pneumatic delay block, terminal designation according to EN 50005								
Size S0								
 3RT19 26-2P...	3RT1. 2	for mounting onto the front of contactors						
		Auxiliary contacts 1 NO and 1 NC ³⁽⁴⁾						
		• ON-delay						
 3RT19 26-2P...	3RT1. 2	0,1 ... 30		C	3RT19 26-2PA01	1	1 unit 41B	
		1 ... 60		C	3RT19 26-2PA11	1	1 unit 41B	
		• OFF-delay						
 3RT19 26-2P...	3RT1. 2	0,1 ... 30		C	3RT19 26-2PR01	1	1 unit 41B	
		1 ... 60		C	3RT19 26-2PR11	1	1 unit 41B	

Function diagrams and circuit diagrams see page 3/34.

1) Cannot be fitted onto 3RT1 and 3RH11 coupling contactors.

2) Not to be used for 3RT10 4. and 3RT13 4. contactors with $U_s \leq 42$ V.

3) In addition to these, no other auxiliary contacts are permitted.

4) Versions according to DIN VDE 0116 on request.

Power Contactors for Switching Motors

Accessories for 3RT1 contactors

Surge suppressors

Selection and ordering data

For contactors	Version	Rated control supply voltage U_s ¹⁾		Power consumption of LED at U_s	DT	Order No. ²⁾	Price € per PU	PU (UNIT, SET, M)	PS*	PG
		AC operation	DC operation							
Type		V AC	V DC	mW						

Surge suppressors with LED

Size S00 (also for spring-type terminals)

For plugging onto the front side of the contactors with and without auxiliary switch blocks



3RT1 16-1L.00

3RT1, 3RH1	Varistor	24 ... 48	12 ... 24	10 ... 120	▶	3RT19 16-1JJ00	1	1 unit	41B
		48 ... 127	24 ... 70	20 ... 470	▶	3RT19 16-1JK00	1	1 unit	41B
		127 ... 240	70 ... 150	50 ... 700	▶	3RT19 16-1JL00	1	1 unit	41B
		--	150 ... 250	160 ... 950	A	3RT19 16-1JP00	1	1 unit	41B
3RT1, 3RH1	Noise suppression diodes	--	24 ... 70	20 ... 470	▶	3RT19 16-1LM00	1	1 unit	41B
		--	50 ... 150	50 ... 700	▶	3RT19 16-1LN00	1	1 unit	41B
		--	150 ... 250	160 ... 950	▶	3RT19 16-1LP00	1	1 unit	41B

1) Can be used for AC operation for 50/60 Hz. Please inquire about further voltages.

2) For packs of 10 or 5 units "-Z" and order code "X90" must be added to the Order No.

For contactors	Version	Rated control supply voltage U_s ¹⁾		DT	Order No. ²⁾	Price € per PU	PU (UNIT, SET, M)	PS*	PG
		AC operation	DC operation						
Type		V AC	V DC						

Surge suppressors without LED

Size S00 (also for spring-type terminals)

For plugging onto the front side of the contactors with and without auxiliary switch blocks



3RT1 16-1DG00

3RT1., 3RH1	Varistor	24 ... 48	24 ... 70	▶	3RT19 16-1BB00	1	1 unit	41B
		48 ... 127	70 ... 150	▶	3RT19 16-1BC00	1	1 unit	41B
		127 ... 240	150 ... 250	A	3RT19 16-1BD00	1	1 unit	41B
		240 ... 400	--	▶	3RT19 16-1BE00	1	1 unit	41B
		400 ... 600	--	A	3RT19 16-1BF00	1	1 unit	41B
3RT1., 3RH1	RC elements	24 ... 48	24 ... 70	▶	3RT19 16-1CB00	1	1 unit	41B
		48 ... 127	70 ... 150	▶	3RT19 16-1CC00	1	1 unit	41B
		127 ... 240	150 ... 250	▶	3RT19 16-1CD00	1	1 unit	41B
		240 ... 400	--	▶	3RT19 16-1CE00	1	1 unit	41B
		400 ... 600	--	▶	3RT19 16-1CF00	1	1 unit	41B
3RT1., 3RH1	Noise suppression diodes	--	12 ... 250	▶	3RT19 16-1DG00	1	1 unit	41B
3RT1., 3RH1	Diode assemblies (diode and Zener diode) for DC operation	--	12 ... 250	▶	3RT19 16-1EH00	1	1 unit	41B

Size S0

For fitting onto the coil terminals at top or bottom



3RT1 26-1B.00

3RT1. 2	Varistor	24 ... 48	24 ... 70	▶	3RT19 26-1BB00	1	1 unit	41B	
		48 ... 127	70 ... 150	▶	3RT19 26-1BC00	1	1 unit	41B	
		127 ... 240	150 ... 250	▶	3RT19 26-1BD00	1	1 unit	41B	
		240 ... 400	--	▶	3RT19 26-1BE00	1	1 unit	41B	
		400 ... 600	--	B	3RT19 26-1BF00	1	1 unit	41B	
3RT1. 2	RC elements	24 ... 48	24 ... 70	▶	3RT19 26-1CB00	1	1 unit	41B	
		48 ... 127	70 ... 150	▶	3RT19 26-1CC00	1	1 unit	41B	
		127 ... 240	150 ... 250	▶	3RT19 26-1CD00	1	1 unit	41B	
		240 ... 400	--	▶	3RT19 26-1CE00	1	1 unit	41B	
		400 ... 600	--	B	3RT19 26-1CF00	1	1 unit	41B	
3RT1. 2	Diode assembly for DC operation	• Connectable at the top (e. g. for contactor with over-load relay)	--	24	▶	3RT19 26-1ER00	1	1 unit	41B
			--	30 ... 250	▶	3RT19 26-1ES00	1	1 unit	41B
		• Connectable at the bottom (e. g. for fuseless load feeders)	--	24	▶	3RT19 26-1TR00	1	1 unit	41B
			--	30 ... 250	A	3RT19 26-1TS00	1	1 unit	41B

1) Can be used for AC operation for 50/60 Hz. Please inquire about further voltages.

2) For packs of 10 units, the Order No. must be supplemented with "-Z" and the order code "X90".

Power Contactors for Switching Motors

Accessories for 3RT1 contactors

Surge suppressors

For contactors	Version	Rated control supply voltage U_s ¹⁾		DT	Order No. ²⁾	Price € per PU	PU (UNIT, SET, M)	PS*	PG
		AC operation	DC operation						
Type		V AC	V DC						

Surge suppressors without LED

Sizes S2 and S3 (also for spring-type terminals)

For fitting onto the coil terminals at top or bottom



3RT19 26-1B.00

For contactors	Version	Rated control supply voltage U_s ¹⁾	DT	Order No. ²⁾	Price € per PU	PU (UNIT, SET, M)	PS*	PG
3RT1. 3, 3RT1. 4	Varistor 	24 ... 48	24 ... 70	▶	3RT19 26-1BB00	1	1 unit	41B
		48 ... 127	70 ... 150	▶	3RT19 26-1BC00	1	1 unit	41B
		127 ... 240	150 ... 250	▶	3RT19 26-1BD00	1	1 unit	41B
		240 ... 400	--	▶	3RT19 26-1BE00	1	1 unit	41B
		400 ... 600	--	B	3RT19 26-1BF00	1	1 unit	41B





3RT19 36-1C.00

For contactors	Version	Rated control supply voltage U_s ¹⁾	DT	Order No. ²⁾	Price € per PU	PU (UNIT, SET, M)	PS*	PG
3RT1. 3 ³⁾ , 3RT1. 4	RC elements 	24 ... 48	24 ... 70	▶	3RT19 36-1CB00	1	1 unit	41B
		48 ... 127	70 ... 150	▶	3RT19 36-1CC00	1	1 unit	41B
		127 ... 240	150 ... 250	▶	3RT19 36-1CD00	1	1 unit	41B
		240 ... 400	--	▶	3RT19 36-1CE00	1	1 unit	41B
		400 ... 600	--	B	3RT19 36-1CF00	1	1 unit	41B

Diode assembly for DC operation



3RT1. 3, 3RT1. 4		• Connectable at the top --	24	▶	3RT19 36-1ER00	1	1 unit	41B
		(e. g. for contactor with over-load relay) --	30 ... 250	▶	3RT19 36-1ES00	1	1 unit	41B
3RT1. 3, 3RT1. 4		• Connectable at the bottom --	24	▶	3RT19 36-1TR00	1	1 unit	41B
		(e. g. for fuseless load feeders) --	30 ... 250	B	3RT19 36-1TS00	1	1 unit	41B

Sizes S6 ... S12

For connecting to withdrawable coil with screw terminals for contactors with
 • conventional operating mechanism 3RT1. ...A...
 • solid-state operating mechanism 3RT1. ...N...



3RT19 56-1C.00

For contactors	Version	Rated control supply voltage U_s ¹⁾	DT	Order No. ²⁾	Price € per PU	PU (UNIT, SET, M)	PS*	PG
3RT1. 5, 3RT1. 6, 3RT1. 7	RC elements 	24 ... 48	24 ... 70	▶	3RT19 56-1CB00	1	1 unit	41B
		48 ... 127	70 ... 150	▶	3RT19 56-1CC00	1	1 unit	41B
		127 ... 240	150 ... 250	▶	3RT19 56-1CD00	1	1 unit	41B
		240 ... 400	--	▶	3RT19 56-1CE00	1	1 unit	41B
		400 ... 600	--	C	3RT19 56-1CF00	1	1 unit	41B

Screw terminals



3RT1. 5, 3RT1. 6, 3RT1. 7	RC elements 	24 ... 48	24 ... 70	▶	3RT19 56-1CB02	1	1 unit	41B
		48 ... 127	70 ... 150	▶	3RT19 56-1CC02	1	1 unit	41B
		127 ... 240	150 ... 250	▶	3RT19 56-1CD02	1	1 unit	41B
		240 ... 400	--	▶	3RT19 56-1CE02	1	1 unit	41B
		400 ... 600	--	C	3RT19 56-1CF02	1	1 unit	41B

Spring-type terminals



- Can be used for AC operation for 50/60 Hz. Please inquire about further voltages.
- For packs of 10 or 5 units "-Z" and order code "X90" must be added to the Order No.
- For 3RT1. 3 with AC operation mountable only at the top.

For contactors	Version	DT	Screw terminals	PU (UNIT, SET, M)	PS*	PG
Type			Order No.	Price € per PU		

Main current path surge suppression modules for 3RT12 vacuum contactors

Size S10 and S12

3RT12	For damping overvoltages and protecting motor windings against multiple re-ignition when switching off induction motors.					
	For connection on the contactor feeder side (2-T1/4-T2/6-T3). For separate installation.					
	Rated operational voltage $U_e = 690$ V AC	C	3RT19 66-1PV3	73,10	1	1 unit 41B
	Rated operational voltage $U_e = 1000$ V AC	C	3RT19 66-1PV4	107,—	1	1 unit 41B

Power Contactors for Switching Motors

Accessories for 3RT1 contactors

Miscellaneous accessories

Selection and ordering data

For contactors	Rated control supply voltage U_s	DT	Screw terminals 	PU (UNIT, SET, M)	PS*	PG
Type	V		Order No.	Price € per PU		

Mechanical latching blocks



3RT19 26-3A.31

Sizes S0 and S2

For mounting on 1 contactor¹⁾

The contactor remains in the energized state even after a voltage failure

3RT1 . 3	24 AC/DC 110 AC/DC 230 AC/DC	A B B	3RT19 26-3AB31 3RT19 26-3AF31 3RT19 26-3AP31	1 1 1	1 unit 1 unit 1 unit	41B 41B 41B
----------	------------------------------------	-------------	---	-------------	----------------------------	-------------------

¹⁾ Two front-mounted auxiliary switch blocks can be mounted in addition.

For contactors	Version	DT	Order No.	Price € per PU	PU (UNIT, SET, M)	PS*	PG
Type							

EMC suppression modules; 3-phase ≤ 5.5 kW

Size S00 (for contactors with AC or DC operation)¹⁾



3RT19 16-1PA.

3RT10 1	RC elements (3 x 220 Ω /0.22 μ F) Up to 400 V Up to 575 V Up to 690 V	▶ ▶ C	3RT19 16-1PA1 3RT19 16-1PA2 3RT19 16-1PA3	1 1 1	1 unit 1 unit 1 unit	41B 41B 41B
3RT10 1	Varistor Up to 400 V Up to 575 V Up to 690 V	A B D	3RT19 16-1PB1 3RT19 16-1PB2 3RT19 16-1PB3	1 1 1	1 unit 1 unit 1 unit	41B 41B 41B

Additional load modules

Size S00 (also for spring-type terminals)

For plugging onto the front side of the contactors with and without auxiliary switch blocks²⁾



3RT19 16-1GA00

3RT1 . 1, 3RH1 .	For increasing the permissible residual current and for limiting the residual voltage. Ensures safe opening of contactors with direct control via 230 V AC semiconductor outputs of SIMATIC controllers. Also performs the function of an overvoltage damping circuit. Rated voltage: AC 50/60 Hz, 180 V to 255 V. Operating range: 0.8 to 1.1 x U_s	▶	3RT19 16-1GA00	1	1 unit	41B
---------------------	--	---	-----------------------	---	--------	-----

Control kit

Size S00



3RK1 903-0CA00

3RT1 . 1, 3RH1 .	For manual operation of the contactor contacts for start-up and service	A	3RK1 903-0CA00	1	1 unit	42D
---------------------	---	---	-----------------------	---	--------	-----

¹⁾ See also description on page 3/33.

²⁾ For packs of 10 units, the Order No. must be supplemented with "-Z" and the order code "X90".

Power Contactors for Switching Motors

Accessories for 3RT1 contactors

Miscellaneous accessories

For contactors	Version	DT	Screw terminals	PU (UNIT, SET, M)	PS*	PG
Type	V		Order No.	Price € per PU		

Coupling links (interfaces) for control by PLC

Sizes S0 to S3

For mounting onto the coil terminals of the contactors With LED for indicating switching state

3RT1 . 2,
3RT1 . 3,
3RT1 . 4

Operating range 17 ... 30 V DC
Power consumption: 0.5 W at 24 V DC
Permissible residual current of the electronics (with 0 signal): 2.5 mA

Rated operational current I_G :

- AC-15/AC-14 at 230 V; 3 A
- DC-13 at 230 V; 0.1 A

With integrated varistor for damping opening surges.

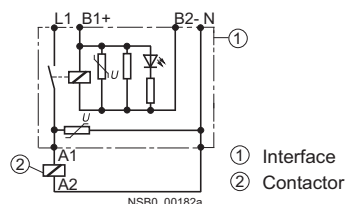

3RH19 24-1GP11

▶ **3RH19 24-1GP11** 1 1 unit 41B

For contactors	Version	DT	Order No.	Price € per PU	PU (UNIT, SET, M)	PS*	PG
Type							

LED modules for indicating contactor operation

Sizes S0 to S12¹⁾ (also for spring-type terminals)

3RT1 . 2 ...
3RT1 . 7

For snapping into the location hole of an inscription label on the front of a contactor either directly on the contactor or on the front auxiliary switch.

The LED module is connected to coil terminals A1 and A2 of the contactor and indicates its energized state. Yellow LED.

Rated voltage:
24 ... 240 V AC/DC with reverse polarity protection.
(1 pack = 5 units)



3RT19 26-1QT00
mounted to contactor

B **3RT19 26-1QT00** 1 5 units 41B

Auxiliary terminals, 3-pole

Size S3

3RT10 4.

For connection of auxiliary and control cables (0.5 to 2.5 mm²) to the main conductor connections (for one side)



3RT19 46-4F





B **3RT19 46-4F** 1 1 unit 41B

¹⁾ For sizes S6 to S12 the connecting leads have to be extended.

Power Contactors for Switching Motors

Accessories for 3RT1 contactors

Miscellaneous accessories

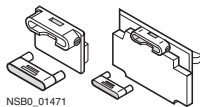
For contactors	Version	DT	Order No.	Price € per PU	PU (UNIT, SET, M)	PS*	PG		
Size	Type								
Box terminal blocks									
	S6	3RT1 . 5 (3RB20 5)	For round and ribbon cables¹⁾						
			Up to 70 mm ² ²⁾	▶	3RT19 55-4G	1	1 unit	41B	
			Up to 120 mm ²	▶	3RT19 56-4G	1	1 unit	41B	
			Auxiliary conductor connection for box terminals	B	3TX7 500-0A	1	1 unit	41B	
	S10, S12	3RT1 . 6, 3RT1 . 7 (3RB20 6, 3RB21 6)	Up to 240 mm ²	▶	3RT19 66-4G	1	1 unit	41B	
			With auxiliary conductor connection						
Covers									
	S2	3RT10 3	Terminal covers for box terminals (additional touch protection) To be fitted at the box terminals (2 units required per contactor)						
			--	▶	3RT19 36-4EA2	1	1 unit	41B	
			3RT13 3, 3RT15 3	For 4-pole contactors	B	3RT19 36-4EA4	1	1 unit	41B
	S3	3RT10 4, 3RT14 4	--	▶	3RT19 46-4EA2	1	1 unit	41B	
			3RT13 4	For 4-pole contactors	B	3RT19 46-4EA4	1	1 unit	41B
	S6³⁾	3RT1 . 5	Length: 25 mm	▶	3RT19 56-4EA2	1	1 unit	41B	
S10, S12³⁾	3RT1 . 6, 3RT1 . 7	Length: 30 mm	▶	3RT19 66-4EA2	1	1 unit	41B		
	S3	3RT10 4, 3RT14 4	Terminal covers for cable lug and busbar connection³⁾ For complying with the phase clearances and as touch protection if box terminal is removed (2 units required per contactor)						
			--	▶	3RT19 46-4EA1	1	1 unit	41B	
	S6	3RT1 . 5	Length: 100 mm	▶	3RT19 56-4EA1	1	1 unit	41B	
	S10/S12	3RT1 . 6, 3RT1 . 7	Length: 120 mm	▶	3RT19 66-4EA1	1	1 unit	41B	
	S6	3RT1 . 5	M8	B	3TX6 526-3B	1	1 unit	41B	
	S10, S12	3RT1 . 6, 3RT1 . 7	M10	B	3TX6 546-3B	1	1 unit	41B	
			Can be screwed on free screw end; covers one busbar connection (1 set = 6 units)						
	S6	3RT1 . 5	Length: 27 mm	▶	3RT19 56-4EA3	1	1 unit	41B	
	S10/S12⁴⁾	3RT1 . 6, 3RT1 . 7	Length: 42 mm	▶	3RT19 66-4EA3	1	1 unit	41B	
			For busbar cover between contactor and 3RB2 overload relay or wiring module for contactor assemblies						
	S6	3RT1 . 5	Length: 38 mm	▶	3RT19 56-4EA4	1	1 unit	41B	
			For busbar cover of the flat line connectors for reversing and wye-delta assemblies						
Sealable covers									
	S00	3RT1 . 1... 3RH1 . ⁵⁾	Sealable covers for preventing manual operation	C	3RT19 16-4MA10	1	5 units	41B	
	S0 ... S12	3RT1 . 3 3RT1 . 7 ⁵⁾	1 unit required per contactor	C	3RT19 26-4MA10	1	5 units	41B	

¹⁾ Connectable cross-sections of the contactors see "Technical Specifications".

²⁾ As standard for 3RT10 54-1 contactor (55 kW).

³⁾ Also fits on contactors S6 to S12 with box terminals.

⁴⁾ The 3RT19 66-4EA3 cover is required in addition for use in contactor assemblies (reversing/wye-delta).

⁵⁾ Exception: contactors and contactor relays auxiliary switch block mounted onto the front.

Power Contactors for Switching Motors

Accessories for 3RT1 contactors

Miscellaneous accessories

For contactors	Version	DT	Order No.	Price € per PU	PU (UNIT, SET, M)	PS*	PG
----------------	---------	----	-----------	-------------------	-------------------------	-----	----

Type

Connection modules for contactors with screw terminals

Size S00, S0



3RT19 26-4RD01

3RT1. 1,
3RT1. 2,
3RH1.

Adapters for contactors

Ambient temperature $T_{U\max.} = 60\text{ °C}$ Size S00,
rated operational current I_e
at AC-3/400 V: 20 ASize S0,
rated operational current I_e
at AC-3/400 V: 25 A

Screw terminals

C **3RT19 16-4RD01** 1 1 unit 41BC **3RT19 26-4RD01** 1 1 unit 41B

3RT19 00-4RE01

Plugs for contactors

Size S00, S0

B **3RT19 00-4RE01** 1 1 unit 41B

Solder pin adapters for contactors

Size S00



3RT19 16-4KA1

3RT1. 1,
3RH11Assembly kit for soldering contactors onto a
printed circuit board.
For 1 contactor, 1 set is required.A **3RT19 16-4KA1** 1 4 units 41B

Solder pin adapters for contactors with mounted 4-pole auxiliary switch block

Size S00

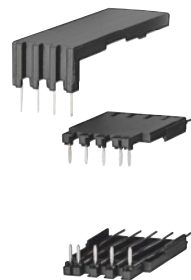

3RT19 16-4KA2

3RT1. 1,
3RH11Assembly kit for soldering contactors with an
auxiliary switch block onto a printed circuit
board.
For 1 contactor, 1 set is required.B **3RT19 16-4KA2** 1 4 units 41B

Screw adapters for fixing the contactors

Size S0

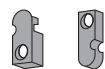
NSB0_01470
3RT19 26-4P





3RT1. 2

Screw adapters for easier screw fixing
2 units required per contactor
(1 pack contains 10 sets for 10 contactors)C **3RT19 26-4P** 1 10 units 41B

Power Contactors for Switching Motors



Accessories for 3RT1 contactors

Miscellaneous accessories

For contactors		Max. conductor cross-sections		DT	Screw terminals 	PU (UNIT, SET, M)	PS*	PG
Size	Type	mm ²			Order No.	Price € per PU		
Links for paralleling								
	3-pole, with connecting terminal¹⁾²⁾							
	S00	3RT10 1	25	▶	3RT19 16-4BB31		1	1 unit 41B
	S0	3RT10 2	35, stranded	▶	3RT19 26-4BB31		1	1 unit 41B
	S2	3RT10 3	95	▶	3RT19 36-4BB31		1	1 unit 41B
3RT19 36-4BB31								
	3-pole, with through hole (star jumpers)¹⁾²⁾							
	S3	3RT10 4, 3RT14 4	185	▶	3RT19 46-4BB31		1	1 unit 41B
	S6	3RT1. 5	--	▶	3RT19 56-4BA31		1	1 unit 41B
	S10/S12	3RT1. 6, 3RT1. 7	--	▶	3RT19 66-4BA31		1	1 unit 41B
3RT19 56-4BA31								
	4-pole, with connecting terminal¹⁾²⁾							
	S00	3RT10 1		C	3RT19 16-4BB41		1	1 unit 41B
3RT19 16-4BB41								

¹⁾ The links for paralleling can be reduced by one pole.

²⁾ Sizes S00 to S2: The links for paralleling are insulated.
 Size S3: A cover plate is included for touch protection (can only be used when the box terminal is removed).
 Sizes S6 to S12: The 3RT19 56-4EA1 (for S6) or 3RT19 66-4EA1 (for S10 and S12) cover can be used for touch protection.

Version	DT	Spring-type terminals 	PU (UNIT, SET, M)	PS*	PG
		Order No.	Price € per PU		
Insulation stop for securely holding back the conductor insulation on conductors up to 1 mm²					
	B	3RT19 16-4JA02	2,40	1	20 units 41B
	Insulation stop strip can be inserted in cable entry of spring-type terminals (2 strips per contactor required, can be removed in pairs) For all SIRIUS devices with spring-type terminals, up to 2.5 mm ² conductor cross-section.				
Tools for opening spring-type terminal points					
	A	3RA29 08-1A		1	1 unit 41B
	For all SIRIUS devices with spring-type terminals, for conductor cross-sections up to 2.5 mm ² . <u>Not suitable for devices with removable terminal</u> Length: approx. 200 mm, 3.0 mm x 0.5 mm, titanium gray/black, partially insulated				
3RA29 08-1A					

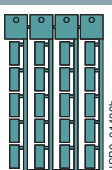
Version	DT	Order No.	Price € per PU	PU (UNIT, SET, M)	PS*	PG
Blank labels						
	C	3RT19 00-1SB10		1	816 units	41B
	D	3RT19 00-1SB20		100	340 units	41B
	C	3RT19 00-1SB60		1	3060 units	41B
	C	3RT19 00-1SD60		1	3060 units	41B
3RT19 00-1SB20						
Unit labeling plates for SIRIUS						
<ul style="list-style-type: none"> • 10 mm x 7 mm, pastel turquoise • 20 mm x 7 mm, pastel turquoise 						
Labels for sticking for SIRIUS						
<ul style="list-style-type: none"> • 19 mm x 6 mm, pastel turquoise • 19 mm x 6 mm, zinc/yellow 						
PC labeling systems						
For individual inscription of unit labeling plates available from: Murrplastik Systemtechnik GmbH (see Chapter 16, "Appendix" → "External Partners")						

Power Contactors for Switching Motors

Spare parts for 3RT1 contactors

Solenoid coils

Selection and ordering data

PU (UNIT, SET, M) = 1
 PS* = 1 unit
 PG = 41B

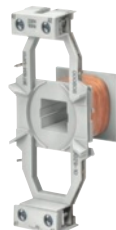

3RT19 34-5A.01

For contactors		Rated control supply voltage U_s			DT	Screw terminals	DT	Spring-type terminals		
Size	Type	50 Hz V	50/60 Hz V	60 Hz V		Order No.	Price € per PU	Order No.	Price € per PU	
Solenoid coils · AC operation										
S0	3RT10 2.,	24	--	--	▶	3RT19 24-5AB01	B	3RT19 24-5AB02		
	3RT13 2.,	42	--	--	A	3RT19 24-5AD01	C	3RT19 24-5AD02		
	3RT15 2.	48	--	--	▶	3RT19 24-5AH01	B	3RT19 24-5AH02		
		110	--	--	▶	3RT19 24-5AF01	B	3RT19 24-5AF02		
		230	--	--	▶	3RT19 24-5AP01	B	3RT19 24-5AP02		
		400	--	--	▶	3RT19 24-5AV01	C	3RT19 24-5AV02		
		--	24	--	▶	3RT19 24-5AC21	B	3RT19 24-5AC22		
		--	42	--	B	3RT19 24-5AD21	C	3RT19 24-5AD22		
		--	48	--	B	3RT19 24-5AH21	C	3RT19 24-5AH22		
		--	110	--	▶	3RT19 24-5AG21	B	3RT19 24-5AG22		
		--	220	--	B	3RT19 24-5AN21	B	3RT19 24-5AN22		
		--	230	--	B	3RT19 24-5AL21	B	3RT19 24-5AL22		
		110	--	120	B	3RT19 24-5AK61	B	3RT19 24-5AK62		
		220	--	240	B	3RT19 24-5AP61	C	3RT19 24-5AP62		
		--	100	110	B	3RT19 24-5AG61	C	3RT19 24-5AG62		
		--	200	220	B	3RT19 24-5AN61	C	3RT19 24-5AN62		
		--	400	440	B	3RT19 24-5AR61	C	3RT19 24-5AR62		
	S2	3RT10 34,	24	--	--	B	3RT19 34-5AB01	B	3RT19 34-5AB02	
			42	--	--	B	3RT19 34-5AD01	B	3RT19 34-5AD02	
			48	--	--	B	3RT19 34-5AH01	B	3RT19 34-5AH02	
		110	--	--	B	3RT19 34-5AF01	B	3RT19 34-5AF02		
		230	--	--	B	3RT19 34-5AP01	B	3RT19 34-5AP02		
		400	--	--	C	3RT19 34-5AV01	B	3RT19 34-5AV02		
		--	24	--	B	3RT19 34-5AC21	B	3RT19 34-5AC22		
		--	42	--	B	3RT19 34-5AD21	B	3RT19 34-5AD22		
		--	48	--	B	3RT19 34-5AH21	B	3RT19 34-5AH22		
		--	110	--	C	3RT19 34-5AG21	B	3RT19 34-5AG22		
		--	220	--	C	3RT19 34-5AN21	B	3RT19 34-5AN22		
		--	230	--	C	3RT19 34-5AL21	B	3RT19 34-5AL22		
		110	--	120	B	3RT19 34-5AK61	B	3RT19 34-5AK62		
		220	--	240	B	3RT19 34-5AP61	B	3RT19 34-5AP62		
		--	100	110	B	3RT19 34-5AG61	B	3RT19 34-5AG62		
		--	200	220	B	3RT19 34-5AN61	B	3RT19 34-5AN62		
		--	400	440	B	3RT19 34-5AR61	B	3RT19 34-5AR62		
3RT10 35,		24	--	--	B	3RT19 35-5AB01	B	3RT19 35-5AB02		
3RT10 36,		42	--	--	B	3RT19 35-5AD01	B	3RT19 35-5AD02		
3RT13 3.,		48	--	--	B	3RT19 35-5AH01	B	3RT19 35-5AH02		
3RT15 3.	110	--	--	▶	3RT19 35-5AF01	B	3RT19 35-5AF02			
	230	--	--	▶	3RT19 35-5AP01	B	3RT19 35-5AP02			
	400	--	--	C	3RT19 35-5AV01	B	3RT19 35-5AV02			
	--	24	--	B	3RT19 35-5AC21	B	3RT19 35-5AC22			
	--	42	--	B	3RT19 35-5AD21	B	3RT19 35-5AD22			
	--	48	--	B	3RT19 35-5AH21	B	3RT19 35-5AH22			
	--	110	--	B	3RT19 35-5AG21	B	3RT19 35-5AG22			
	--	220	--	B	3RT19 35-5AN21	B	3RT19 35-5AN22			
	--	230	--	B	3RT19 35-5AL21	B	3RT19 35-5AL22			
	110	--	120	B	3RT19 35-5AK61	B	3RT19 35-5AK62			
	220	--	240	B	3RT19 35-5AP61	B	3RT19 35-5AP62			
	--	100	110	B	3RT19 35-5AG61	B	3RT19 35-5AG62			
	--	200	220	B	3RT19 35-5AN61	B	3RT19 35-5AN62			
	--	400	440	C	3RT19 35-5AR61	B	3RT19 35-5AR62			

Power Contactors for Switching Motors

Spare parts for 3RT1 contactors

Solenoid coils

PU (UNIT, SET, M) = 1
 PS* = 1 unit
 PG = 41B



3RT19 44-5A.01



3RT19 45-5A.01



3RT19 45-5A.02



3RT19 44-5B.42

For contactors		Rated control supply voltage U_s				DT	Screw terminals		DT	Spring-type terminals	
Size	Type	AC	50/60 Hz		DC	Order No.	Price € per PU	Order No.	Price € per PU		
		50 Hz V	50/60 Hz V	60 Hz V	V						
Solenoid coils · AC operation											
S3	3RT10 44	24	--	--	--	B	3RT19 44-5AB01	B	3RT19 44-5AB02		
		42	--	--	--	B	3RT19 44-5AD01	B	3RT19 44-5AD02		
		48	--	--	--	B	3RT19 44-5AH01	B	3RT19 44-5AH02		
		110	--	--	--	B	3RT19 44-5AF01	B	3RT19 44-5AF02		
		230	--	--	--	B	3RT19 44-5AP01	B	3RT19 44-5AP02		
		400	--	--	--	B	3RT19 44-5AV01	B	3RT19 44-5AV02		
		--	24	--	--	--	B	3RT19 44-5AC21	B	3RT19 44-5AC22	
		--	42	--	--	--	B	3RT19 44-5AD21	B	3RT19 44-5AD22	
		--	48	--	--	--	B	3RT19 44-5AH21	B	3RT19 44-5AH22	
		--	110	--	--	--	B	3RT19 44-5AG21	B	3RT19 44-5AG22	
		--	220	--	--	--	B	3RT19 44-5AN21	B	3RT19 44-5AN22	
		--	230	--	--	--	B	3RT19 44-5AL21	B	3RT19 44-5AL22	
	110	--	120	--	--	B	3RT19 44-5AK61	B	3RT19 44-5AK62		
	220	--	240	--	--	B	3RT19 44-5AP61	B	3RT19 44-5AP62		
	--	100	110	--	--	B	3RT19 44-5AG61	B	3RT19 44-5AG62		
	--	200	220	--	--	B	3RT19 44-5AN61	B	3RT19 44-5AN62		
	--	--	400	440	--	B	3RT19 44-5AR61	B	3RT19 44-5AR62		
	3RT10 45,	24	--	--	--	B	3RT19 45-5AB01	B	3RT19 45-5AB02		
	3RT10 46,	42	--	--	--	B	3RT19 45-5AD01	B	3RT19 45-5AD02		
	3RT13 4.,	48	--	--	--	B	3RT19 45-5AH01	B	3RT19 45-5AH02		
	3RT14 46,	110	--	--	--	B	3RT19 45-5AF01	B	3RT19 45-5AF02		
	3RT15 4.	230	--	--	--	▶	3RT19 45-5AP01	B	3RT19 45-5AP02		
		400	--	--	--	C	3RT19 45-5AV01	B	3RT19 45-5AV02		
	--	24	--	--	--	B	3RT19 45-5AC21	B	3RT19 45-5AC22		
--	42	--	--	--	B	3RT19 45-5AD21	B	3RT19 45-5AD22			
--	48	--	--	--	B	3RT19 45-5AH21	B	3RT19 45-5AH22			
--	110	--	--	--	B	3RT19 45-5AG21	B	3RT19 45-5AG22			
--	220	--	--	--	B	3RT19 45-5AN21	B	3RT19 45-5AN22			
--	230	--	--	--	B	3RT19 45-5AL21	B	3RT19 45-5AL22			
110	--	120	--	--	B	3RT19 45-5AK61	B	3RT19 45-5AK62			
220	--	240	--	--	B	3RT19 45-5AP61	B	3RT19 45-5AP62			
--	100	110	--	--	B	3RT19 45-5AG61	B	3RT19 45-5AG62			
--	200	220	--	--	C	3RT19 45-5AN61	B	3RT19 45-5AN62			
--	--	400	440	--	B	3RT19 45-5AR61	B	3RT19 45-5AR62			
Solenoid coils · DC operation											
S2	3RT10 3.,	--	--	--	24	B	3RT19 34-5BB41	B	3RT19 34-5BB42		
	3RT13 3.,	--	--	--	42	B	3RT19 34-5BD41	C	3RT19 34-5BD42		
	3RT15 3.	--	--	--	48	B	3RT19 34-5BW41	B	3RT19 34-5BW42		
	--	--	--	--	60	B	3RT19 34-5BE41	B	3RT19 34-5BE42		
	--	--	--	--	110	B	3RT19 34-5BF41	B	3RT19 34-5BF42		
	--	--	--	--	125	B	3RT19 34-5BG41	C	3RT19 34-5BG42		
	--	--	--	--	220	B	3RT19 34-5BM41	B	3RT19 34-5BM42		
	--	--	--	--	230	B	3RT19 34-5BP41	B	3RT19 34-5BP42		
	S3	3RT10 4.,	--	--	--	24	B	3RT19 44-5BB41	B	3RT19 44-5BB42	
		3RT13 4.,	--	--	--	42	C	3RT19 44-5BD41	B	3RT19 44-5BD42	
		3RT14 4.,	--	--	--	48	B	3RT19 44-5BW41	B	3RT19 44-5BW42	
		3RT15 4.	--	--	--	60	B	3RT19 44-5BE41	B	3RT19 44-5BE42	
--		--	--	--	110	B	3RT19 44-5BF41	B	3RT19 44-5BF42		
--		--	--	--	125	B	3RT19 44-5BG41	B	3RT19 44-5BG42		
--		--	--	--	220	B	3RT19 44-5BM41	B	3RT19 44-5BM42		
--		--	--	--	230	B	3RT19 44-5BP41	B	3RT19 44-5BP42		

Power Contactors for Switching Motors

Spare parts for 3RT1 contactors

Solenoid coils

PU (UNIT, SET, M) = 1
 PS* = 1 unit
 PG = 41B



3RT19 55-5A...

For contactors		Rated control supply voltage $U_{s \text{ min}} \dots U_{s \text{ max}}$	DT	Screw terminals	DT	Spring-type terminals	
Size	Type	V AC/DC		Order No.	Price € per PU	Order No.	Price € per PU
Withdrawable coils							
Conventional operating mechanisms							
S6	3RT10 5, 3RT14 5	23 ... 26	B	3RT19 55-5AB31	B	3RT19 55-5AB32	
		42 ... 48	B	3RT19 55-5AD31	B	3RT19 55-5AD32	
	110 ... 127	B	3RT19 55-5AF31	B	3RT19 55-5AF32		
	200 ... 220	B	3RT19 55-5AM31	B	3RT19 55-5AM32		
	220 ... 240	B	3RT19 55-5AP31	B	3RT19 55-5AP32		
	240 ... 277	B	3RT19 55-5AU31	B	3RT19 55-5AU32		
	380 ... 420	B	3RT19 55-5AV31	B	3RT19 55-5AV32		
	440 ... 480	B	3RT19 55-5AR31	B	3RT19 55-5AR32		
	500 ... 550	B	3RT19 55-5AS31	B	3RT19 55-5AS32		
	575 ... 600	B	3RT19 55-5AT31	B	3RT19 55-5AT32		
S10	3RT10 6, 3RT14 6	23 ... 26	B	3RT19 65-5AB31	B	3RT19 65-5AB32	
		42 ... 48	B	3RT19 65-5AD31	B	3RT19 65-5AD32	
	110 ... 127	B	3RT19 65-5AF31	B	3RT19 65-5AF32		
	200 ... 220	C	3RT19 65-5AM31	B	3RT19 65-5AM32		
	220 ... 240	B	3RT19 65-5AP31	B	3RT19 65-5AP32		
	240 ... 277	B	3RT19 65-5AU31	B	3RT19 65-5AU32		
	380 ... 420	B	3RT19 65-5AV31	B	3RT19 65-5AV32		
	440 ... 480	B	3RT19 65-5AR31	B	3RT19 65-5AR32		
	500 ... 550	C	3RT19 65-5AS31	B	3RT19 65-5AS32		
	575 ... 600	C	3RT19 65-5AT31	B	3RT19 65-5AT32		
S10	3RT12 6 vacuum con- tactors	23 ... 26	B	3RT19 66-5AB31		--	
		42 ... 48	B	3RT19 66-5AD31		--	
	110 ... 127	A	3RT19 66-5AF31		--		
	200 ... 220	C	3RT19 66-5AM31		--		
	220 ... 240	A	3RT19 66-5AP31		--		
	240 ... 277	C	3RT19 66-5AU31		--		
	380 ... 420	B	3RT19 66-5AV31		--		
	440 ... 480	C	3RT19 66-5AR31		--		
	500 ... 550	C	3RT19 66-5AS31		--		
	575 ... 600	C	3RT19 66-5AT31		--		
S12	3RT10 7, 3RT14 7, 3RT12 7 vacuum con- tactors	23 ... 26	B	3RT19 75-5AB31	B	3RT19 75-5AB32	
		42 ... 48	B	3RT19 75-5AD31	B	3RT19 75-5AD32	
	110 ... 127	B	3RT19 75-5AF31	B	3RT19 75-5AF32		
	200 ... 220	C	3RT19 75-5AM31	B	3RT19 75-5AM32		
	220 ... 240	B	3RT19 75-5AP31	B	3RT19 75-5AP32		
	240 ... 277	B	3RT19 75-5AU31	B	3RT19 75-5AU32		
	380 ... 420	B	3RT19 75-5AV31	B	3RT19 75-5AV32		
	440 ... 480	B	3RT19 75-5AR31	B	3RT19 75-5AR32		
	500 ... 550	C	3RT19 75-5AS31	B	3RT19 75-5AS32		
	575 ... 600	C	3RT19 75-5AT31	B	3RT19 75-5AT32		

Power Contactors for Switching Motors

Spare parts for 3RT1 contactors

Solenoid coils

PU (UNIT, SET, M) = 1
 PS* = 1 unit
 PG = 41B



3RT19 55-5N...

For contactors			Rated control supply voltage U_s	DT	Screw terminals	DT	Spring-type terminals	
Size	Type	V AC/DC			Order No.	Price € per PU	Order No.	Price € per PU
Withdrawable coils								
Solid-state operating mechanism								
For 24 V DC PLC output								
S6	3RT10 5,	21 ... 27,3	C	3RT19 55-5NB31	B	3RT19 55-5NB32		
	3RT14 5	96 ... 127	B	3RT19 55-5NF31	B	3RT19 55-5NF32		
		200 ... 277	B	3RT19 55-5NP31	B	3RT19 55-5NP32		
S10	3RT10 6,	21 ... 27,3	B	3RT19 65-5NB31	B	3RT19 65-5NB32		
	3RT14 6	96 ... 127	B	3RT19 65-5NF31	B	3RT19 65-5NF32		
		200 ... 277	B	3RT19 65-5NP31	B	3RT19 65-5NP32		
S12	3RT12 6	21 ... 27,3	B	3RT19 66-5NB31		--		
	vacuum con-	96 ... 127	C	3RT19 66-5NF31		--		
	tactors	200 ... 277	C	3RT19 66-5NP31		--		
S12	3RT10 7,	21 ... 27,3	B	3RT19 75-5NB31	B	3RT19 75-5NB32		
	3RT14 7,	96 ... 127	B	3RT19 75-5NF31	B	3RT19 75-5NF32		
	3RT12 7	200 ... 277	B	3RT19 75-5NP31	B	3RT19 75-5NP32		
	vacuum con-							
	tactors							
For 24 V DC PLC output/PLC relay output, with remaining lifetime indicator (RLT) (withdrawable coil with laterally mounted solid-state module)								
S6	3RT10 5,	96 ... 127	B	3RT19 55-5PF31		--		
	3RT14 5	200 ... 277	B	3RT19 55-5PP31		--		
S10	3RT10 6,	96 ... 127	B	3RT19 65-5PF31		--		
	3RT14 6	200 ... 277	B	3RT19 65-5PP31		--		
S12	3RT10 7,	96 ... 127	B	3RT19 75-5PF31		--		
	3RT14 7	200 ... 277	B	3RT19 75-5PP31		--		
With AS-Interface interface and remaining lifetime indicator (RLT) (withdrawable coil with laterally mounted solid-state module)								
S6	3RT10 5,	96 ... 127	B	3RT19 55-5QF31		--		
	3RT14 5	200 ... 277	B	3RT19 55-5QP31		--		
S10	3RT10 6,	96 ... 127	B	3RT19 65-5QF31		--		
	3RT14 6	200 ... 277	B	3RT19 65-5QP31		--		
S12	3RT10 7,	96 ... 127	B	3RT19 75-5QF31		--		
	3RT14 7	200 ... 277	B	3RT19 75-5QP31		--		

Power Contactors for Switching Motors

Spare parts for 3RT1 contactors

Contacts and arc chutes

Selection and ordering data

For contactors	Version	DT	Order No.	Price € per PU	PU (UNIT, SET, M)	PS*	PG
Size	Type						
Contacts with fixing parts							
For contactors with 3 main contacts							
S2	3RT10 34	Main contacts (3 NO contacts) for utilization category AC-3 (1 set = 3 movable and 6 fixed switching elements with fixing parts)	▶ 3RT19 34-6A		1	1 unit	41B
	3RT10 35		▶ 3RT19 35-6A		1	1 unit	41B
	3RT10 36		▶ 3RT19 36-6A		1	1 unit	41B
S3	3RT10 44		▶ 3RT19 44-6A		1	1 unit	41B
	3RT10 45		▶ 3RT19 45-6A		1	1 unit	41B
	3RT10 46		▶ 3RT19 46-6A		1	1 unit	41B
S6	3RT10 54		▶ 3RT19 54-6A		1	1 unit	41B
	3RT10 55		▶ 3RT19 55-6A		1	1 unit	41B
	3RT10 56		▶ 3RT19 56-6A		1	1 unit	41B
S10	3RT10 64		▶ 3RT19 64-6A		1	1 unit	41B
	3RT10 65		▶ 3RT19 65-6A		1	1 unit	41B
	3RT10 66		▶ 3RT19 66-6A		1	1 unit	41B
S12	3RT10 75		▶ 3RT19 75-6A		1	1 unit	41B
	3RT10 76		A 3RT19 76-6A		1	1 unit	41B
S3	3RT14 46	Main contacts (3 NO contacts) for utilization category AC-1 (1 set = 3 movable and 6 fixed switching elements with fixing parts)	B 3RT19 46-6D		1	1 unit	41B
S6	3RT14 56		B 3RT19 56-6D		1	1 unit	41B
S10	3RT14 66		B 3RT19 66-6D		1	1 unit	41B
S12	3RT14 76		A 3RT19 76-6D		1	1 unit	41B
For 3RT12 vacuum contactors							
S10	3RT12 64	3 vacuum interrupters with fixing parts	B 3RT19 64-6V		1	1 unit	41B
	3RT12 65		B 3RT19 65-6V		1	1 unit	41B
	3RT12 66		B 3RT19 66-6V		1	1 unit	41B
S12	3RT12 75		B 3RT19 75-6V		1	1 unit	41B
	3RT12 76		B 3RT19 76-6V		1	1 unit	41B
For contactors with 4 main contacts							
S2	3RT13 36	Main contacts (4 NO contacts) for utilization category AC-1 (1 set = 4 movable and 8 fixed switching elements with fixing parts)	C 3RT19 36-6E		1	1 unit	41B
S3	3RT13 44		C 3RT19 44-6E		1	1 unit	41B
	3RT13 46		B 3RT19 46-6E		1	1 unit	41B
Arc chutes							
S2	3RT10 3.	Arc chutes, 3-pole	C 3RT19 36-7A		1	1 unit	41B
S3	3RT10 4., 3RT14 46		B 3RT19 46-7A		1	1 unit	41B
S6	3RT10 54		B 3RT19 54-7A		1	1 unit	41B
	3RT10 55		B 3RT19 55-7A		1	1 unit	41B
	3RT10 56		B 3RT19 56-7A		1	1 unit	41B
S10	3RT10 64		B 3RT19 64-7A		1	1 unit	41B
	3RT10 65		B 3RT19 65-7A		1	1 unit	41B
	3RT10 66		B 3RT19 66-7A		1	1 unit	41B
S12	3RT10 75		B 3RT19 75-7A		1	1 unit	41B
	3RT10 76		B 3RT19 76-7A		1	1 unit	41B
S6	3RT14 56		B 3RT19 56-7B		1	1 unit	41B
S10	3RT14 66		B 3RT19 66-7B		1	1 unit	41B
S12	3RT14 76		B 3RT19 76-7B		1	1 unit	41B

SIRIUS 3RT10 coupling contactors (interface),
3-pole, 3 ... 11 kW

Overview

DC operation

IEC 60947-1, EN 60947-1,
IEC 60947-4-1, EN 60947-4-1,
IEC 60947-5-1, EN 60947-5-1 (auxiliary switches)

The 3RT10 coupling contactors for switching motors are tailored to the special requirements of working with electronic controls.

The 3RT10 1 coupling contactors cannot be extended with auxiliary switch blocks.

Two single-pole auxiliary switch blocks can be fitted to the 3RT10 2 coupling contactors (see [Accessories on page 3/38](#)).

Coupling contactors have a low power consumption and an extended solenoid coil operating range.

Depending on the version, the solenoid coils are supplied either without overvoltage damping (3RT10 1.-1HB4. and 3RT10 1.-.MB4.-0KT0) or with a diode, suppressor diode or varistor connected as standard.

Selection and ordering data

DC operation

Low power consumption

Extended operating range of the solenoid coil



PU (UNIT, SET, M) = 1
PS* = 1 UNIT
PG = 41B



3RT10 1.-1.B4.



3RT10 1.-2.B4.

Rated data		Auxiliary contacts		DT	Screw terminals		DT	Spring-type terminals	
AC-2 and AC-3 T_u : Up to 60 °C									
Operational current I_e up to	Rating of induction motors at 50 Hz and	Ident. No.	Version		Order No.	Price € per PU		Order No.	Price € per PU
400 V	400 V		 						
A	kW		NO NC						

For screw and snap-on mounting onto
TH 35 standard mounting rail

Size S00

Diode, varistor or RC element, attachable

- With auxiliary contact 1 NO, Ident. No. **10**

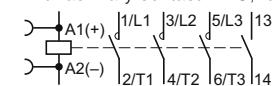

- With auxiliary contact 1 NC, Ident. No. **01**

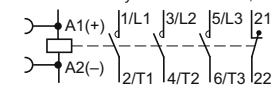

$U_s = 24$ V DC, coil operating range **0.7 to 1.25** x U_s
Power consumption of the coils **2.3 W** at 24 V

7	3	10	1	--	▶	3RT10 15-1HB41	B	3RT10 15-2HB41
		01	--	1	▶	3RT10 15-1HB42	B	3RT10 15-2HB42
9	4	10	1	--	▶	3RT10 16-1HB41	B	3RT10 16-2HB41
		01	--	1	▶	3RT10 16-1HB42	B	3RT10 16-2HB42
12	5,5	10	1	--	A	3RT10 17-1HB41	B	3RT10 17-2HB41
		01	--	1	B	3RT10 17-1HB42	B	3RT10 17-2HB42

$U_s = 24$ V DC, coil operating range **0.85 to 1.85** x U_s
Power consumption of the coils **1.4 W** at 24 V

7	3	10	1	--	B	3RT10 15-1MB41-0KT0	B	3RT10 15-2MB41-0KT0
		01	--	1	B	3RT10 15-1MB42-0KT0	B	3RT10 15-2MB42-0KT0
9	4	10	1	--	B	3RT10 16-1MB41-0KT0	B	3RT10 16-2MB41-0KT0
		01	--	1	B	3RT10 16-1MB42-0KT0	B	3RT10 16-2MB42-0KT0
12	5,5	10	1	--	B	3RT10 17-1MB41-0KT0	B	3RT10 17-2MB41-0KT0
		01	--	1	B	3RT10 17-1MB42-0KT0	B	3RT10 17-2MB42-0KT0

Surge suppressors see page 3/43.

Coupling Contactors

SIRIUS 3RT10 coupling contactors (interface), 3-pole, 3 ... 11 kW

DC operation

Low power consumption

Extended operating range of the solenoid coil

Coil with integrated surge suppression

PU (UNIT, SET, M) = 1
 PS* = 1 UNIT
 PG = 41B



3RT10 1.-1.B4.



3RT10 1.-2.B4.

Rated data		Auxiliary contacts		DT	Screw terminals		DT	Spring-type terminals	
AC-2 and AC-3 T _i : Up to 60 °C									
Operational current I _o up to	Rating of induction motors at 50 Hz and	Ident. No.	Version		Order No.	Price € per PU		Order No.	Price € per PU
400 V	400 V								
A	kW								

For screw and snap-on mounting onto TH 35 standard mounting rail

Size S00

With integrated coil circuit (diode)

- 1 NO, Ident. No. **10**

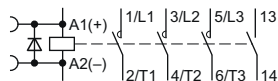

- 1 NC, Ident. No. **01**

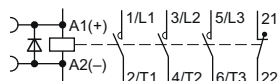

U_s = 24 V DC, coil operating range **0.7 to 1.25 x U_s**
 Power consumption of the coils **2.3 W** at 24 V

7	3	10 01	1 --	-- 1	▶	3RT10 15-1JB41 3RT10 15-1JB42	▶	3RT10 15-2JB41 3RT10 15-2JB42
9	4	10 01	1 --	-- 1	▶	3RT10 16-1JB41 3RT10 16-1JB42	▶	3RT10 16-2JB41 3RT10 16-2JB42
12	5,5	10 01	1 --	-- 1	▶	3RT10 17-1JB41 3RT10 17-1JB42	▶	3RT10 17-2JB41 3RT10 17-2JB42

U_s = 24 V DC, coil operating range **0.85 to 1.85 x U_s**
 Power consumption of the coils **1.4 W** at 24 V

7	3	10 01	1 --	-- 1	B	3RT10 15-1VB41 3RT10 15-1VB42	B	3RT10 15-2VB41 3RT10 15-2VB42
9	4	10 01	1 --	-- 1	B	3RT10 16-1VB41 3RT10 16-1VB42	B	3RT10 16-2VB41 3RT10 16-2VB42
12	5,5	10 01	1 --	-- 1	B	3RT10 17-1VB41 3RT10 17-1VB42	B	3RT10 17-2VB41 3RT10 17-2VB42

Coupling Contactors

**SIRIUS 3RT10 coupling contactors (interface),
3-pole, 3 ... 11 kW**

- DC operation**
- Low power consumption**
- Extended operating range of the solenoid coil**
- Coil with integrated surge suppression**

PU (UNIT, SET, M) = 1
 PS* = 1 UNIT
 PG = 41B



3RT10 1.-1.B4.



3RT10 1.-2.B4.

Rated data		Auxiliary contacts		DT	Screw terminals		DT	Spring-type terminals	
AC-2 and AC-3 T _i : Up to 60 °C		Ident. No. Version			Order No.	Price € per PU		Order No.	Price € per PU
Operational current I _e up to 400 V	Rating of induction motors at 50 Hz and 400 V kW			NO NC					

**For screw and snap-on mounting onto
TH 35 standard mounting rail**

Size S00

With integrated coil circuit (varistor)

- 1 NO, Ident. No. **10**

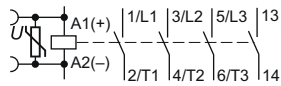

- 1 NC, Ident. No. **01**

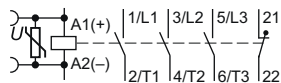

U_s = 24 V DC, coil operating range **0.7 to 1.25 x U_s**
 Power consumption of the coils **2.3 W** at 24 V

7	3	10 01	1 --	-- 1	▶	3RT10 15-1KB41 3RT10 15-1KB42	▶	3RT10 15-2KB41 3RT10 15-2KB42	
9	4	10 01	1 --	-- 1	▶	3RT10 16-1KB41 3RT10 16-1KB42	▶	3RT10 16-2KB41 3RT10 16-2KB42	
12	5,5	10 01	1 --	-- 1	▶	3RT10 17-1KB41 3RT10 17-1KB42	▶	3RT10 17-2KB41 3RT10 17-2KB42	
U _s = 24 V DC, coil operating range 0.85 to 1.85 x U_s Power consumption of the coils 1.4 W at 24 V									
7	3	10 01	1 --	-- 1	A B	3RT10 15-1WB41 3RT10 15-1WB42	B B	3RT10 15-2WB41 3RT10 15-2WB42	
9	4	10 01	1 --	-- 1	B B	3RT10 16-1WB41 3RT10 16-1WB42	B B	3RT10 16-2WB41 3RT10 16-2WB42	
12	5,5	10 01	1 --	-- 1	B B	3RT10 17-1WB41 3RT10 17-1WB42	B B	3RT10 17-2WB41 3RT10 17-2WB42	

Coupling Contactors

SIRIUS 3RT10 coupling contactors (interface), 3-pole, 3 ... 11 kW

DC operation

Low power consumption

Extended operating range of the solenoid coil

Coil with integrated surge suppression

PU (UNIT, SET, M) = 1
 PS* = 1 UNIT
 PG = 41B



3RT10 2.-1KB40



3RT10 2.-3KB40

Rated data AC-2 and AC-3 T_U : Up to 60 °C		Auxiliary contacts		DT	Screw terminals	DT	Spring-type terminals for coil terminals	
Operational current I_e up to	Rating of induction motors at 50 Hz and	Ident. No.	Version		Order No.	Price € per PU	Order No.	Price € per PU
400 V	400 V		 					
A	kW							

For screw and snap-on mounting onto TH 35 standard mounting rail

Size S0

With integrated coil circuit (varistor)

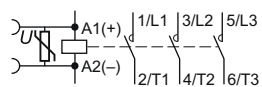

$U_s = 24$ V DC, coil operating range **0.7 to 1.25 x U_s**
 Power consumption of the coils **4.2 W** at 24 V

Varistor mounted	5,5	--	--	--	▶	3RT10 24-1KB40	B	3RT10 24-3KB40
	7,5	--	--	--	▶	3RT10 25-1KB40	▶	3RT10 25-3KB40
	11	--	--	--	▶	3RT10 26-1KB40	▶	3RT10 26-3KB40

Accessories [see page 3/38](#).

Contactor Assemblies

3RA13, 3RA14 Contactor Assemblies

SIRIUS 3RA13 reversing contactor assemblies

Overview

The 3RA13 reversing contactor assemblies can be ordered as follows:

Sizes S00 to S3

- Fully wired and tested, with mechanical and electrical interlock
- For assemblies with AC operation and 50/60 Hz, a dead interval of 50 ms must be provided when used with voltages ≥ 500 V; a dead interval of 30 ms is recommended for use with voltages ≥ 400 V. These dead times do not apply to assemblies with DC operation.

Sizes S00 to S12

- As individual parts for customer assembly

There is also a range of accessories (auxiliary switch blocks, surge suppressors, etc.) that must be ordered separately.

Overload relays for motor protection [see Chapter 7 "Protection Equipment" → "Overload Relays"](#).

The 3RA13 contactor assemblies have screw terminals and are suitable for screw and snap-on mounting onto TH 35 standard mounting rails.

Complete units

The fully wired reversing contactor assemblies are suitable for use in any climate. They are finger-safe according to EN 50274.

The contactor assemblies consist of 2 contactors with the same power, with one NC contact in the basic unit. The contactors are mechanically and electrically interlocked (NC contact interlock).

For motor protection, either 3RU11 or 3RB2. overload relays for direct mounting or stand-alone installation or thermistor motor protection tripping units must be ordered separately.

Components for customer assembly

Assembly kits for all sizes are available for customer assembly of reversing contactor assemblies.

Contactors, overload relays, the mechanical interlock (as of size S2) and – for momentary-contact operation – auxiliary switch blocks for latching must be ordered separately.

Rated data AC-2 and AC-3 for 50 Hz 400 V AC		Size	Order No.				Assembly kit	Fully wired and tested contactor assemblies
Rating kW	Operational current I_e A		Contactor	Mechanical interlocks ¹⁾	Mechanical interlocks ²⁾	Mechanical interlocks ³⁾		
3	7	S00	3RT10 15	-- ⁴⁾	--	--	3RA19 13-2A ⁵⁾	3RA13 15-8XB30-1 ..
4	9		3RT10 16					3RA13 16-8XB30-1 ..
5,5	12		3RT10 17					3RA13 17-8XB30-1 ..
5,5	12	S0	3RT10 24	3RA19 24-1A	3RA19 24-2B	--	3RA19 23-2A ⁶⁾	3RA13 24-8XB30-1 ..
7,5	17		3RT10 25					3RA13 25-8XB30-1 ..
11	25		3RT10 26					3RA13 26-8XB30-1 ..
15	32	S2	3RT10 34	3RA19 24-1A	3RA19 24-2B	--	3RA19 33-2A ⁷⁾	3RA13 34-8XB30-1...
18,5	40		3RT10 35					3RA13 35-8XB30-1...
22	50		3RT10 36					3RA13 36-8XB30-1...
30	65	S3	3RT10 44	3RA19 24-1A	3RA19 24-2B	--	3RA19 43-2A ⁷⁾	3RA13 44-8XB30-1...
37	80		3RT10 45					3RA13 45-8XB30-1...
45	95		3RT10 46					3RA13 46-8XB30-1...
55	115	S6	3RT10 54	--	--	3RA19 54-2A	3RA19 53-2M ⁸⁾	--
75	150		3RT10 55					
90	185		3RT10 56					
110	225	S10	3RT10 64	--	--	3RA19 54-2A	3RA19 63-2A ⁸⁾	--
132	265		3RT10 65					
160	300		3RT10 66					
200	400	S12	3RT10 75	--	--	3RA19 54-2A	3RA19 73-2A ⁸⁾	--
250	500		3RT10 76					

¹⁾ Can be mounted onto the front.

²⁾ Laterally mountable with one auxiliary contact.

³⁾ Laterally mountable without auxiliary contact.

⁴⁾ Interlock can only be ordered with assembly kit.

⁵⁾ Assembly kit contains: mechanical interlock; connecting clips for 2 contactors; wiring modules on the top and bottom.

⁶⁾ Assembly kit contains: wiring modules on the top and bottom.

⁷⁾ Assembly kit contains: 2 connecting clips for contactors; wiring modules on the top and bottom.

⁸⁾ Assembly kit contains: wiring module on the top and bottom.

Contactors Assemblies

3RA13, 3RA14 Contactor Assemblies

SIRIUS 3RA13 reversing contactor assemblies

Selection and ordering data

Fully wired and tested contactor assemblies · Size S00 · up to 5.5 kW



3RA13 1..-8XB30-1...

Rated data AC-2 and AC-3		Ratings of induction motors at 50 Hz and				Rated control supply voltage U_s ¹⁾	DT	Screw terminals		PU (UNIT, SET, M)	PS*	PG
Operational current I_e up to	400 V	500 V	690 V	Order No.	Price € per PU							
A	kW	kW	kW	V								
AC operation, 50/60 Hz												
7	2,2	3	3,5	4	24 AC	A	3RA13 15-8XB30-1AB0		1	1 unit	41B	
					110 AC	A	3RA13 15-8XB30-1AF0		1	1 unit	41B	
					230 AC	A	3RA13 15-8XB30-1AP0		1	1 unit	41B	
9	3	4	4,5	5,5	24 AC	A	3RA13 16-8XB30-1AB0		1	1 unit	41B	
					110 AC	A	3RA13 16-8XB30-1AF0		1	1 unit	41B	
					230 AC	A	3RA13 16-8XB30-1AP0		1	1 unit	41B	
12	3	5,5	5,5	5,5	24 AC	A	3RA13 17-8XB30-1AB0		1	1 unit	41B	
					110 AC	A	3RA13 17-8XB30-1AF0		1	1 unit	41B	
					230 AC	A	3RA13 17-8XB30-1AP0		1	1 unit	41B	
DC operation												
7	2,2	3	3,5	4	24 DC	▶	3RA13 15-8XB30-1BB4		1	1 unit	41B	
9	3	4	4,5	5,5	24 DC	▶	3RA13 16-8XB30-1BB4		1	1 unit	41B	

¹⁾ Coil operating range at 50 Hz: 0,8 ... 1,1 x U_s ; at 60 Hz: 0,85 ... 1,1 x U_s .

Note:

The contactors integrated in the contactor assemblies have no unassigned auxiliary contacts.

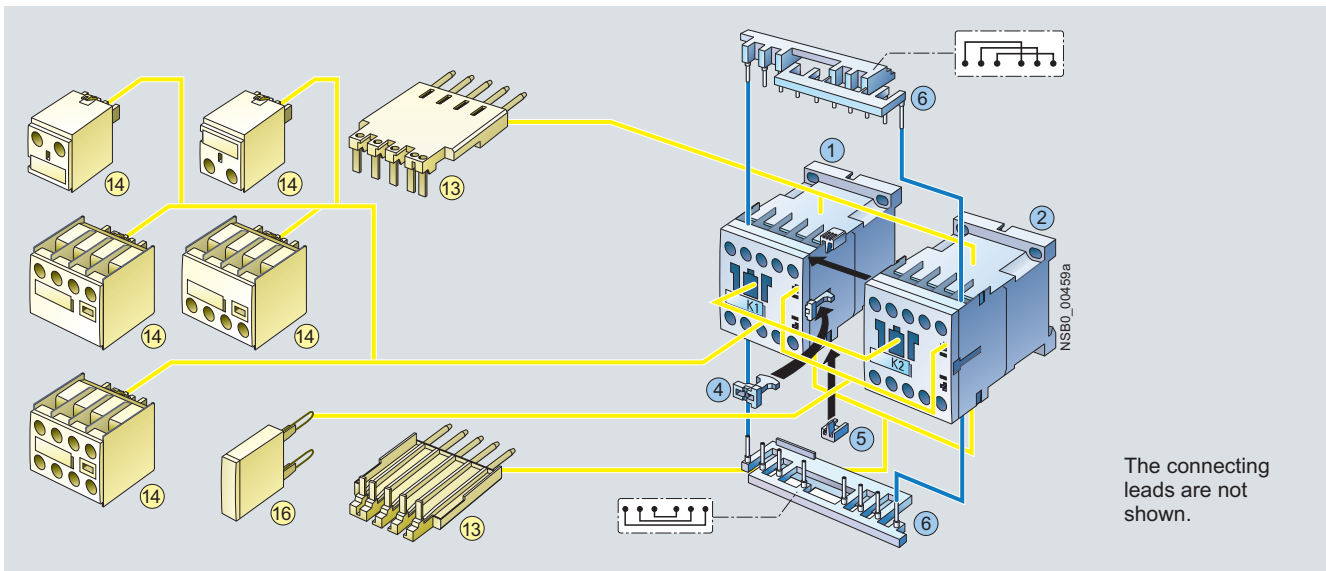

The connecting leads are not shown.

Mountable accessories (optional)		
To be ordered separately	Order No.	Page
13 Solder pin adapters	3RT19 16-4KA1	3/66
14 Auxiliary switch block, front (according to EN 50005 must be used)	3RH19 11-1...	3/36
16 Surge suppressor	3RT19 16-1...	3/43

Complete contactor assemblies			
Individual parts		Order No.	Page
		K1	K2
1 2	Contactors, 3 kW	3RT10 15	3RT10 15
1 2	Contactors, 4 kW	3RT10 16	3RT10 16
1 2	Contactors, 5.5 kW	3RT10 17	3RT10 17
4 5 6	Assembly kit	3RA19 13-2A	3/65

The assembly kit contains:

- 4** Mechanical interlock
- 5** 2 connecting clips for 2 contactors
- 6** Wiring modules on the top and bottom for connecting the main current paths, electrical interlock included¹⁾, interruptible (NC contact interlock)

¹⁾ 3RT10 1. contactors with one NC contact in the basic unit are required for the electrical interlock.

Contactor Assemblies

3RA13, 3RA14 Contactor Assemblies

SIRIUS 3RA13 reversing contactor assemblies

Fully wired and tested contactor assemblies - Size S0 - up to 11 kW



3RA13 2.-8XB30-1...

Rated data AC-2 and AC-3					Rated control supply voltage U_s ¹⁾	DT	Screw terminals		PU (UNIT, SET, M)	PS*	PG
Operational current I_e up to	Ratings of induction motors at 50 Hz and						Order No.	Price € per PU			
400 V	230 V	400 V	500 V	690 V							
A	kW	kW	kW	kW	V						
AC operation, 50/60 Hz											
12	3	5,5	7,5	7,5	24 AC	A	3RA13 24-8XB30-1AC2		1	1 unit	41B
					110 AC	A	3RA13 24-8XB30-1AG2		1	1 unit	41B
					230 AC	▶	3RA13 24-8XB30-1AL2		1	1 unit	41B
17	4	7,5	10	11	24 AC	A	3RA13 25-8XB30-1AC2		1	1 unit	41B
					110 AC	A	3RA13 25-8XB30-1AG2		1	1 unit	41B
					230 AC	▶	3RA13 25-8XB30-1AL2		1	1 unit	41B
25	5,5	11	11	11	24 AC	A	3RA13 26-8XB30-1AC2		1	1 unit	41B
					110 AC	A	3RA13 26-8XB30-1AG2		1	1 unit	41B
					230 AC	A	3RA13 26-8XB30-1AL2		1	1 unit	41B
DC operation											
12	3	5,5	7,5	7,5	24 DC	▶	3RA13 24-8XB30-1BB4		1	1 unit	41B
17	4	7,5	10	11	24 DC	A	3RA13 25-8XB30-1BB4		1	1 unit	41B
25	5,5	11	11	11	24 DC	A	3RA13 26-8XB30-1BB4		1	1 unit	41B

¹⁾ Coil operating range at 50 Hz: 0,8 ... 1,1 × U_s ; at 60 Hz: 0,85 ... 1,1 × U_s .

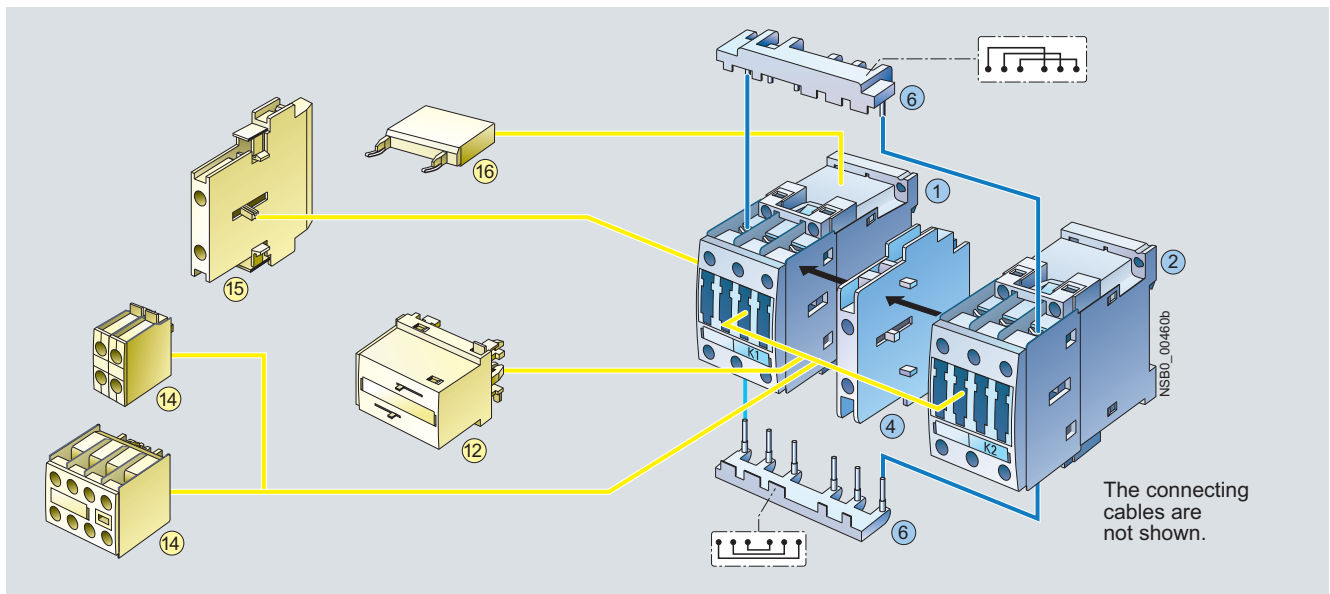

Mountable accessories (optional)		
To be ordered separately	Order No.	Page
12 Mechanical interlock, front	3RA19 24-1A	3/64
14 Auxiliary switch block, front	3RH19 21-1CA..	3/35
15 Auxiliary switch block, lateral	3RH19 21-1EA..	3/39
16 Surge suppressor	3RT19 26-1....	3/43

Complete contactor assemblies			
Individual parts		Order No.	Page
		K1	K2
1 2	Contactor, 5,5 kW	3RT10 24	3RT10 24
1 2	Contactor, 7,5 kW	3RT10 25	3RT10 25
1 2	Contactor, 11 kW	3RT10 26	3RT10 26
4	Mechanical interlock, lateral	3RA19 24-2B	3/64
6	Assembly kit	3RA19 23-2A	3/65

The assembly kit contains wiring modules on the top and bottom (they also form the mechanical connection between the contactors).

Contactor Assemblies

3RA13, 3RA14 Contactor Assemblies

SIRIUS 3RA13 reversing contactor assemblies

Fully wired and tested contactor assemblies - Size S2 - up to 22 kW



3RA13 3.-8XB30-1...

Rated data AC-2 and AC-3					Rated control supply voltage U_s ¹⁾	DT	Screw terminals		PU (UNIT, SET, M)	PS*	PG
Operational current I_e up to	Ratings of induction motors at 50 Hz and						Order No.	Price € per PU			
500 V	230 V	400 V	500 V	690 V							
A	kW	kW	kW	kW	V						
AC operation, 50/60 Hz											
32	7,5	15	18,5	18,5	24 AC	A	3RA13 34-8XB30-1AC2		1	1 unit	41B
					110 AC	A	3RA13 34-8XB30-1AG2		1	1 unit	41B
					230 AC	A	3RA13 34-8XB30-1AL2		1	1 unit	41B
40	11	18,5	22	22	24 AC	A	3RA13 35-8XB30-1AC2		1	1 unit	41B
					110 AC	A	3RA13 35-8XB30-1AG2		1	1 unit	41B
					230 AC	A	3RA13 35-8XB30-1AL2		1	1 unit	41B
50	15	22	30	22	24 AC	B	3RA13 36-8XB30-1AC2		1	1 unit	41B
					110 AC	B	3RA13 36-8XB30-1AG2		1	1 unit	41B
					230 AC	A	3RA13 36-8XB30-1AL2		1	1 unit	41B
DC operation											
32	7,5	15	18,5	18,5	24 DC	A	3RA13 34-8XB30-1BB4		1	1 unit	41B
40	11	18,5	22	22	24 DC	A	3RA13 35-8XB30-1BB4		1	1 unit	41B
50	15	22	30	22	24 DC	A	3RA13 36-8XB30-1BB4		1	1 unit	41B

¹⁾ Coil operating range at 50 Hz: 0,8 ... 1.1 x U_s ; at 60 Hz: 0,85 ... 1.1 x U_s .

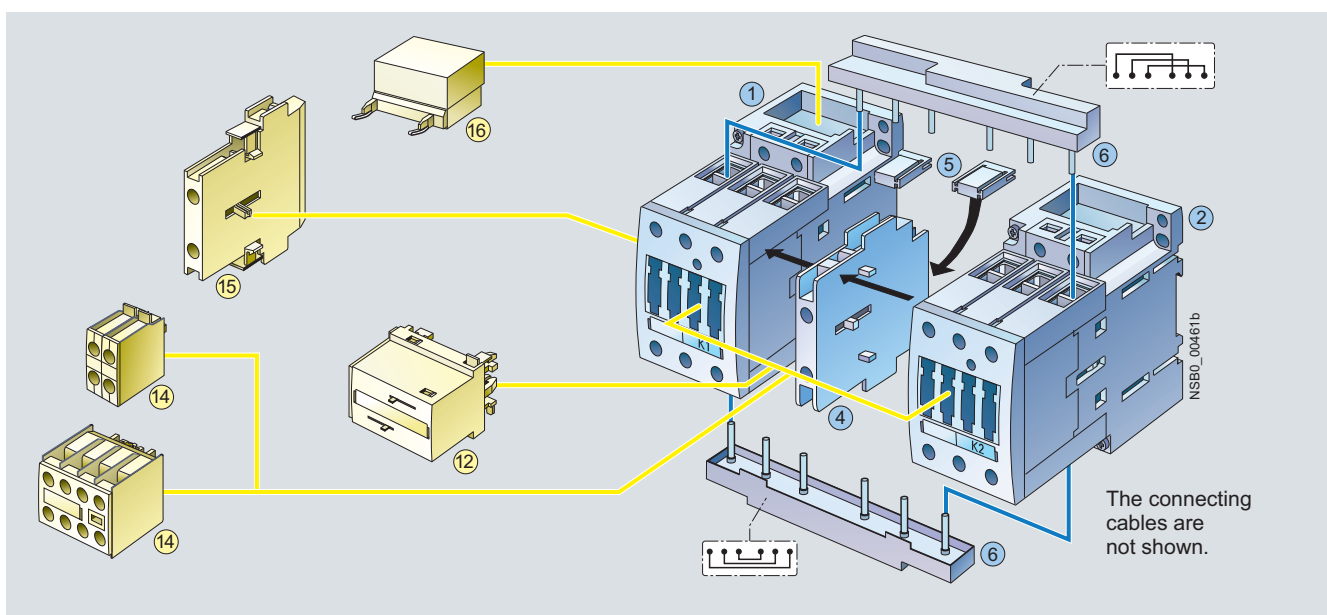

Mountable accessories (optional)		
To be ordered separately	Order No.	Page
12 Mechanical interlock, front	3RA19 24-1A	3/64
14 Auxiliary switch block, front	3RH19 21-1CA..	3/35
15 Auxiliary switch block, lateral	3RH19 21-1EA..	3/39
16 Surge suppressor	3RT19 26-1... 3RT19 36-1...	3/44

Complete contactor assemblies			
Individual parts		Order No.	Page
		K1	K2
1 2	Contactor, 15 kW	3RT10 34	3RT10 34
1 2	Contactor, 18.5 kW	3RT10 35	3RT10 35
1 2	Contactor, 22 kW	3RT10 36	3RT10 36
4	Mechanical interlock, lateral	3RA19 24-2B	3/64
5 6	Assembly kit	3RA19 33-2A	3/65
The assembly kit contains:			
5	2 connecting clips for 2 contactors with 10 mm distance		
6	Wiring modules on the top and bottom for connecting the main current paths		

Contactor Assemblies

3RA13, 3RA14 Contactor Assemblies

SIRIUS 3RA13 reversing contactor assemblies

Fully wired and tested contactor assemblies - Size S3 - up to 45 kW



3RA13 4.-8XB30-1...

Rated data AC-2 and AC-3					Rated control supply voltage $U_s^{1)}$	DT	Screw terminals		PU (UNIT, SET, M)	PS*	PG
Operational current I_e up to	Ratings of induction motors at 50 Hz and						Order No.	Price € per PU			
500 V	230 V	400 V	500 V	690 V							
A	kW	kW	kW	kW	V						
AC operation at 50/60 Hz											
65	18,5	30	37	45	24 AC	B	3RA13 44-8XB30-1AC2		1	1 unit	41B
					110 AC	B	3RA13 44-8XB30-1AG2		1	1 unit	41B
					230 AC	B	3RA13 44-8XB30-1AL2		1	1 unit	41B
80	22	37	45	55	24 AC	B	3RA13 45-8XB30-1AC2		1	1 unit	41B
					110 AC	B	3RA13 45-8XB30-1AG2		1	1 unit	41B
					230 AC	B	3RA13 45-8XB30-1AL2		1	1 unit	41B
95	22	45	55	55	24 AC	B	3RA13 46-8XB30-1AC2		1	1 unit	41B
					110 AC	B	3RA13 46-8XB30-1AG2		1	1 unit	41B
					230 AC	B	3RA13 46-8XB30-1AL2		1	1 unit	41B
DC operation											
65	18,5	30	37	45	24 DC	B	3RA13 44-8XB30-1BB4		1	1 unit	41B
80	22	37	45	55	24 DC	B	3RA13 45-8XB30-1BB4		1	1 unit	41B
95	22	45	55	55	24 DC	B	3RA13 46-8XB30-1BB4		1	1 unit	41B

¹⁾ Coil operating range at 50 Hz: 0,8 ... 1.1 x U_s ; at 60 Hz: 0,85 ... 1.1 x U_s .

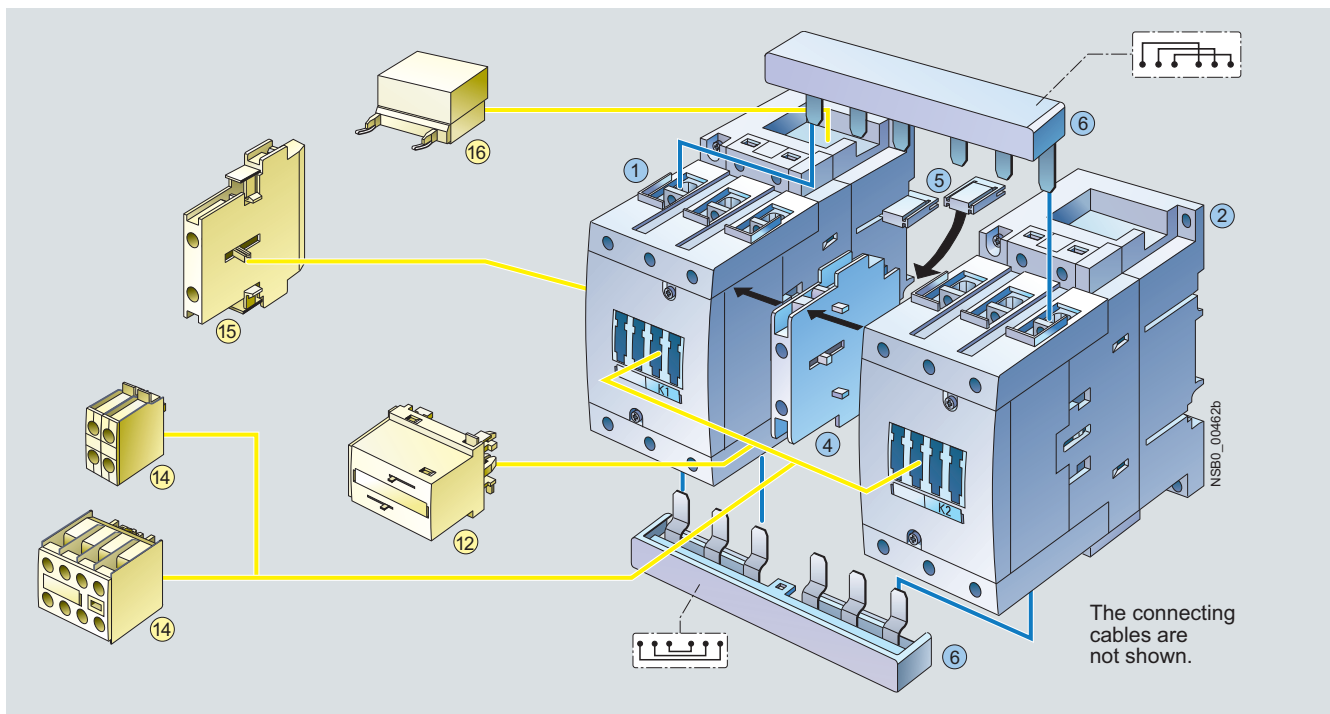

Mountable accessories (optional)

To be ordered separately	Order No.	Page
12 Mechanical interlock, front	3RA19 24-1A	3/64
14 Auxiliary switch block, front	3RH19 21-1CA..	3/35
15 Auxiliary switch block, lateral	3RH19 21-1EA..	3/39
16 Surge suppressor	3RT19 26-1.... 3RT19 36-1....	3/44

Complete contactor assemblies

Individual parts	Order No. K1	K2	Page
1 2 Contactor, 30 kW	3RT10 44	3RT10 44	3/18
1 2 Contactor, 37 kW	3RT10 45	3RT10 45	3/18
1 2 Contactor, 45 kW	3RT10 46	3RT10 46	3/18
4 Mechanical interlock, lateral	3RA19 24-2B		3/64
5 6 Assembly kit	3RA19 43-2A		3/65

The assembly kit contains:





- 5** 2 connecting clips for 2 contactors with 10 mm distance
- 6** Wiring modules on the top and bottom for connecting the main current paths

Contactor Assemblies

3RA13, 3RA14 Contactor Assemblies

SIRIUS 3RA13 reversing contactor assemblies

Components for customer assembly

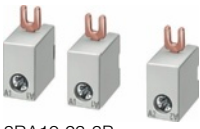
For contactors	Size	Version	Order No.	Price € per PU	PU (UNIT, SET, M)	PS*	PG
Mechanical interlocks							
 <p>3RA19 24-1A mounted onto 2 contactors</p>	3RT10 2	S0	Laterally mountable¹⁾ Each with one auxiliary contact (1 NC contact) per contactor (can only be used to connect contactors which are not more than 1 size larger or smaller). The mounting depth of the smaller contactor has to be adapted.)	▶	3RA19 24-2B	1	1 unit 41B
	3RT10 3	S2					
	3RT10 4	S3					
 <p>3RA19 54-2A</p>	3RT10 2	S0	Can be mounted onto the front²⁾ Onto contactor sizes S2 and S3 (for contactors of the same size) Note: Size S0: Wiring modules must be mounted first. Sizes S2 and S3: Use 3RA19 32-2C mechanical connectors.	▶	3RA19 24-1A	1	1 unit 41B
	3RT10 3	S2					
	3RT10 4	S3					
	3RT13 2						
	3RT15 2						
 <p>3RA19 54-2C</p>	3RT1 . 5	S6	Laterally mountable, without auxiliary contacts Contactor sizes S6, S10 and S12 can be interlocked with each other as required; no adaptation of mounting depth is necessary. Contactor clearance 10 mm.	▶	3RA19 54-2A	1	1 unit 41B
	3RT1 . 6	S10					
	3RT1 . 7	S12					
 <p>3RA19 54-2C</p>	3RT10 4.-A	S3	Adapters, laterally mountable; for mechanical interlocking of contactor S3 (only for AC operation) with contactor S6 using 3RA19 54-2A locking device (must be ordered separately) incl. connecting clips	▶	3RA19 54-2C	1	1 unit 41B
	with 3RT10 5	S6					
Coil repeat terminals							
 <p>3RA19 23-3B</p>	3RT10 3	S2, S3	For the coil terminals A1 and A2 for reversing starters (contactor sizes S2 and S3). 2 x A1 and 1 x A2 required per assembly (one set contains 10 x A1 and 5 x A2)	B	3RA19 23-3B	1	1 unit 41B
	3RT10 4						
Base plates							
	3RT10 5	S6	For customer assembly of reversing contactor assemblies	B	3RA19 52-2A	1	1 unit 41B
	3RT1 . 6	S10		B	3RA19 62-2A	1	1 unit 41B
	3RT1 . 7	S12		B	3RA19 72-2A	1	1 unit 41B





¹⁾ Can also be used for 4-pole contactors with sizes S2 and S3.

²⁾ Can also be used for size S0 4-pole contactors.

Contactor Assemblies

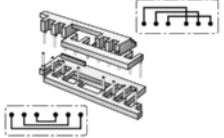
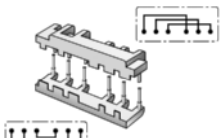
3RA13, 3RA14 Contactor Assemblies

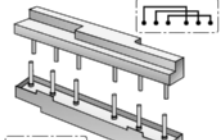
SIRIUS 3RA13 reversing contactor assemblies

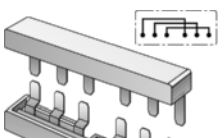
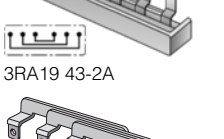
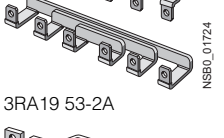
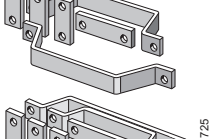
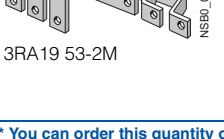
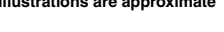
For contactors	Size	Version	DT	Order No.	Price € per PU	PU (UNIT, SET, M)	PS*	PG
Assembly kits for making 3-pole contactor assemblies								
	3RT10 1	S00	The assembly kit contains: mechanical interlock; 2 connecting clips for 2 contactors; wiring modules on the top and bottom	▶	3RA19 13-2A		1	1 unit 41B
	3RA19 13-2A							
	3RT10 2	S0	The assembly kit contains: wiring modules on the top and bottom	▶	3RA19 23-2A		1	1 unit 41B
	3RA19 23-2A							
	3RT10 3	S2	The assembly kit contains: 2 connecting clips for 2 contactors; wiring modules on the top and bottom	▶	3RA19 33-2A		1	1 unit 41B
	3RA19 33-2A							
	3RT10 4	S3	The assembly kit contains: 2 connecting clips for 2 contactors; wiring modules on the top and bottom	▶	3RA19 43-2A		1	1 unit 41B
	3RA19 43-2A							
	3RT10 5	S6	The assembly kit contains: Wiring modules on the top and bottom (for connection with box terminal)	▶	3RA19 53-2A		1	1 unit 41B
	3RA19 53-2A							
	3RT10 5 3RT1. 6 3RT1. 7	S6 S10 S12	The assembly kit contains: Wiring modules on the top and bottom (for connection without box terminal)	A	3RA19 53-2M 3RA19 63-2A 3RA19 73-2A		1 1 1	1 unit 41B 1 unit 41B 1 unit 41B
	3RA19 53-2M							

Contactors Assemblies

3RA13, 3RA14 Contactor Assemblies

SIRIUS 3RA13 reversing contactor assemblies

For contactors	Size	Contact-clearance	Version	DT	Order No.	Price € per PU	PU (UNIT, SET, M)	PS*	PG
Type		mm							
Wiring modules, single									
3RT10 1	S00-S00	0	Top (in-phase)	▶	3RA19 13-3D		1 5 units		41B
			Bottom (with phase reversal)	▶	3RA19 13-3E		1 5 units		41B
3RT10 2	S0-S0 and S0-S0	0 and 10	Top (in-phase)	▶	3RA19 23-3D		1 5 units		41B
			Bottom (with phase reversal)	▶	3RA19 23-3E		1 5 units		41B
3RT10 3	S2-S2	10	Top (in-phase)	▶	3RA19 33-3D		1 1 unit		41B
			Bottom (with phase reversal)	▶	3RA19 33-3E		1 1 unit		41B
3RT10 4	S3-S3	10	Top (in-phase)	▶	3RA19 43-3D		1 1 unit		41B
			Bottom (with phase reversal)	▶	3RA19 43-3E		1 1 unit		41B
3RT10 5	S6-S6	10	Top (in-phase, for connection with box terminal)	A	3RA19 53-3D		1 1 unit		41B
			Top (with phase reversal, for connection without box terminal)	A	3RA19 53-3P		1 1 unit		41B

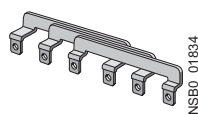

3RA19 53-3D

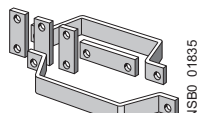

3RA19 53-3P

For contactors	Size	Contact-clearance	Interlocking	Version	DT	Order No.	Price € per PU	PU (UNIT, SET, M)	PS*	PG
Type		mm								
Mechanical connectors						1 pack = 10 units for 10 combinations				
3RT1. 1 ¹⁾	S00-S00	0	Lateral	For 3- and 4-pole contactors	▶	3RA19 12-2H		1 10 units		41B
			On front	For 3- and 4-pole contactors	A	3RA19 22-2C		1 10 units		41B
3RT1. 2	S0-S0	0 10 ²⁾	Lateral		▶	3RT19 22-2D		100 20 units		41B
			On front	For 3-pole contactors	▶	3RA19 32-2C		1 10 units		41B
3RT1. 3	S2-S2	0								
3RT1. 4	S3-S3									
3RT1. 3	S2-S2	10	Lateral	For 3-pole contactors	▶	3RA19 32-2D		1 10 units		41B
			Lateral	For 4-pole contactors	A	3RA19 32-2G		1 10 units		41B
			Lateral	For 4-pole contactors	B	3RA19 42-2G		1 10 units		41B



3RA19 12-2H



3RA19 22-2C



3RA19 32-2C



3RA19 32-2D



3RA19 32-2G



3RA19 42-2G

¹⁾ This pack contains 10 additional interlocks.

²⁾ The connector function can be fulfilled with the wiring modules for size S0, a contactor clearance of 10 mm and a lateral interlock.

Contactor Assemblies

3RA13, 3RA14 Contactor Assemblies

**SIRIUS 3RA14 contactor assemblies
for wye-delta starting**

Overview

These 3RA14 contactor assemblies for wye-delta starting are designed for standard applications.

Note:

Contactor assemblies for wye-delta starting in special applications such as very heavy starting¹⁾ or wye-delta starting of special motors must be customized. Help with designing such special applications is available from Technical Assistance.

The 3RA14 contactor assemblies for wye-delta starting can be ordered as follows:

Sizes S00 to S3

- Fully wired and tested, with electrical interlock, dead interval of up to 10 s on reversing (size S00 with electrical and mechanical interlocks)

Sizes S00 to S12

- As individual parts for customer assembly

A dead interval of 50 ms on reversing is already integrated in the time relay function.

There is also a range of accessories (auxiliary switch blocks, surge suppressors, etc.) that must be ordered separately.

Overload relays for motor protection see Chapter 7 "Protection Equipment" → "Overload Relays" → "SIRIUS 3RB2 Solid-State Overload Relays".

The 3RA14 contactor assemblies have screw terminals and are suitable for screw and snap-on mounting onto TH 35 standard mounting rails.

Fully wired and tested 3RA14 contactor assemblies have one unassigned NO contact which is mounted onto the front of the K3 delta contactor.

A solid-state time-delay auxiliary switch block is snapped onto the front of the complete contactor assemblies, size S00 up to 7.5 kW, while a timing relay is mounted onto the side of sizes S0 to S3, 11 kW to 75 kW.

- ¹⁾ For effective support from Technical Assistance you must provide the following details:
- Rated motor voltage
 - Rated motor current
 - Service factor, operating values
 - Motor starting current factor
 - Starting time
 - Ambient temperature

Rated data at 50 Hz 400 V AC			Size		Order No. complete	
Rating P kW	Operational current I_e A	Motor current A	Line/delta contactor	Star contactor		
5,5	12	9,5 ... 13,8	S00-S00-S00	3RT10 15	3RT10 15	3RA14 15-8XB31-1...
7,5	17	12,1 ... 17		3RT10 17		3RA14 16-8XB31-1...
11	25	19 ... 25	S0-S0-S0	3RT10 24	3RT10 24	3RA14 23-8XC21-1...
15	32	24,1 ... 34		3RT10 26		3RA14 25-8XC21-1...
18,5	40	34,5 ... 40				
22	50	31 ... 43	S2-S2-S0	3RT10 34	3RT10 26	3RA14 34-8XC21-1...
30	50	48,3 ... 65		3RT10 34		--
37	80	62,1 ... 77,8	S2-S2-S2		3RT10 34	3RA14 35-8XC21-1...
45	86	69 ... 86		3RT10 36		3RA14 36-8XC21-1...
55	115	77,6 ... 108,6	S3-S3-S2	3RT10 44	3RT10 35	3RA14 44-8XC21-1...
75	150	120,7 ... 150		3RT10 45	3RT10 36	3RA14 45-8XC21-1...
90	160	86 ... 160	S6-S6-S3	3RT10 54	3RT10 44	--
110	195	86 ... 195				
132	230	86 ... 230		3RT10 55	3RT10 45	
160	280	86 ... 280		3RT10 56	3RT10 46	
200	350	95 ... 350	S10-S10-S6	3RT10 64	3RT10 54	--
250	430	95 ... 430		3RT10 65	3RT10 55	
315	540	277 ... 540	S12-S12-S10	3RT10 75	3RT10 64	--
355	610	277 ... 610				
400	690	277 ... 690			3RT10 65	
500	850	277 ... 850		3RT10 76	3RT10 66	

Contactors Assemblies

3RA13, 3RA14 Contactor Assemblies

SIRIUS 3RA14 contactor assemblies for wye-delta starting

Components for customer assembly

Assembly kits with wiring modules and, if necessary, mechanical connectors are available for contactor assemblies for wye-delta starting. Contactors, overload relays, wye-delta timing relays, auxiliary switches for electrical interlock – if required also feeder terminals, mechanical interlocks and base plates – must be ordered separately (exception: in the case of the assembly kit for size S00 contactor assemblies, the mechanical interlock between the delta contactor and the star contactor is included in the kit).

The wiring kits for sizes S00 and S0 contain the top and bottom main conducting path connections between the line and delta contactors (top) and between the delta and star contactors (bottom).

In the case of sizes S2 to S12 only the bottom main conducting path connection between the delta and star contactors is included in the wiring module, owing to the larger conductor cross-section at the infeed.

Motor protection

Overload relays or thermistor motor protection releases can be used for overload protection.

The overload relay can be either mounted onto the line contactor or separately fitted. It must be set to 0.58 times the rated motor current.

Note:

The selection of contactor types refers to fused configurations.

P kW	Accessories for customer assembly					Overload relay, thermal (CLASS 10 trip class)		Overload relay, solid-state (CLASS 10 trip class)	
	Timing relays	Assembly kit A, for double infeed	Assembly kit B, for single infeed	Star jumper	Base plates	Setting range A	Order No.	Setting range A	Order No.
5,5	3RT19 16-2G.51	--	3RA19 13-2B ¹⁾	--	--	5,5 ... 8	3RU11 16-1HB0	3 ... 12	3RB20 16-1SB0
7,5	3RP15 74-1N.30					7 ... 10	3RU11 16-1JB0		
11	3RP15 74-1N.30	--	3RA19 23-2B ²⁾	--	--	11 ... 16	3RU11 26-4AB0	6 ... 25	3RB20 26-1QB0
15						14 ... 20	3RU11 26-4BB0		
18,5						20 ... 25	3RU11 26-4DB0		
22	3RP15 74-1N.30	3RA19 33-2C ³⁾	3RV19 35-1A	3RT19 26-4BA31	3RA19 32-2E	18 ... 25	3RU11 36-4DB0	12,5 ... 50	3RB20 36-1UB0
30						28 ... 40	3RU11 36-4FB0		
37	3RP15 74-1N.30	3RA19 33-2B ³⁾	3RV19 35-1A	3RT19 36-4BA31	3RA19 32-2F	36 ... 45	3RU11 36-4GB0	12,5 ... 50	3RB20 36-1UB0
45						40 ... 50	3RU11 36-4HB0		
55	3RP15 74-1N.30	3RA19 43-2C ³⁾	--	3RT19 36-4BA31	3RA19 42-2E	45 ... 63	3RU11 46-4JB0	25 ... 100	3RB20 46-1EB0
75						70 ... 90	3RU11 46-4LB0		
90	3RP15 74-1N.30	--	3RA19 53-3D ⁴⁾	3RT19 46-4BA31	3RA19 52-2E	--	--	50 ... 200	3RB20 56-1FC2
110									
132									
160									
200	3RP15 74-1N.30	--	--	3RT19 56-4BA31	3RA19 62-2E	--	--	55 ... 250	3RB20 66-1GC2
250								160 ... 630	3RB20 66-1MC2
315	3RP15 74-1N.30	--	--	3RT19 66-4BA31	3RA19 72-2E	--	--	160 ... 630	3RB20 66-1MC2
355									
400									
500									

¹⁾ Assembly kit contains mechanical interlock, 3 connecting clips; wiring modules on the top (connection between line and delta contactor) and on the bottom (connection between delta and star contactor); star jumper.

²⁾ Assembly kit contains 5 connecting clips; wiring modules on the top (connection between line and delta contactor) and on the bottom (connection between delta and star contactor); star jumper.

³⁾ Assembly kit contains wiring module on the bottom (connection between delta and star contactor) and star jumper.

⁴⁾ Wiring module on top from reversing contactor assembly (note conductor cross-sections).

Contactor Assemblies

3RA13, 3RA14 Contactor Assemblies

SIRIUS 3RA14 contactor assemblies for wye-delta starting

Selection and ordering data

Fully wired and tested contactor assemblies · Size S00-S00-S00 · up to 7.5 kW



3RA14 1.-8XB31-1...

Rated data AC-3					Rated control supply voltage $U_s^{1)}$	DT	Screw terminals		PU (UNIT, SET, M)	PS*	PG
Operational current I_e up to	Ratings of induction motors at 50 Hz and						Order No.	Price € per PU			
400 V	230 V	400 V	500 V	690 V							
A	kW	kW	kW	kW	V						
AC operation, 50/60 Hz											
12	3,3	5,5	7,2	9,2	24 AC	B	3RA14 15-8XB31-1AB0	1	1 unit	41B	
					110 AC	B	3RA14 15-8XB31-1AF0	1	1 unit	41B	
					230 AC	▶	3RA14 15-8XB31-1AP0	1	1 unit	41B	
17	4,7	7,5	10,3	9,2	24 AC	B	3RA14 16-8XB31-1AB0	1	1 unit	41B	
					110 AC	B	3RA14 16-8XB31-1AF0	1	1 unit	41B	
					230 AC	▶	3RA14 16-8XB31-1AP0	1	1 unit	41B	
DC operation											
12	3,3	5,5	7,2	9,2	24 DC	B	3RA14 15-8XB31-1BB4	1	1 unit	41B	
17	4,7	7,5	10,3	9,2	24 DC	▶	3RA14 16-8XB31-1BB4	1	1 unit	41B	

1) Coil operating range at 50 Hz: 0,8 ... 1.1 x U_s ; at 60 Hz: 0,85 ... 1.1 x U_s .

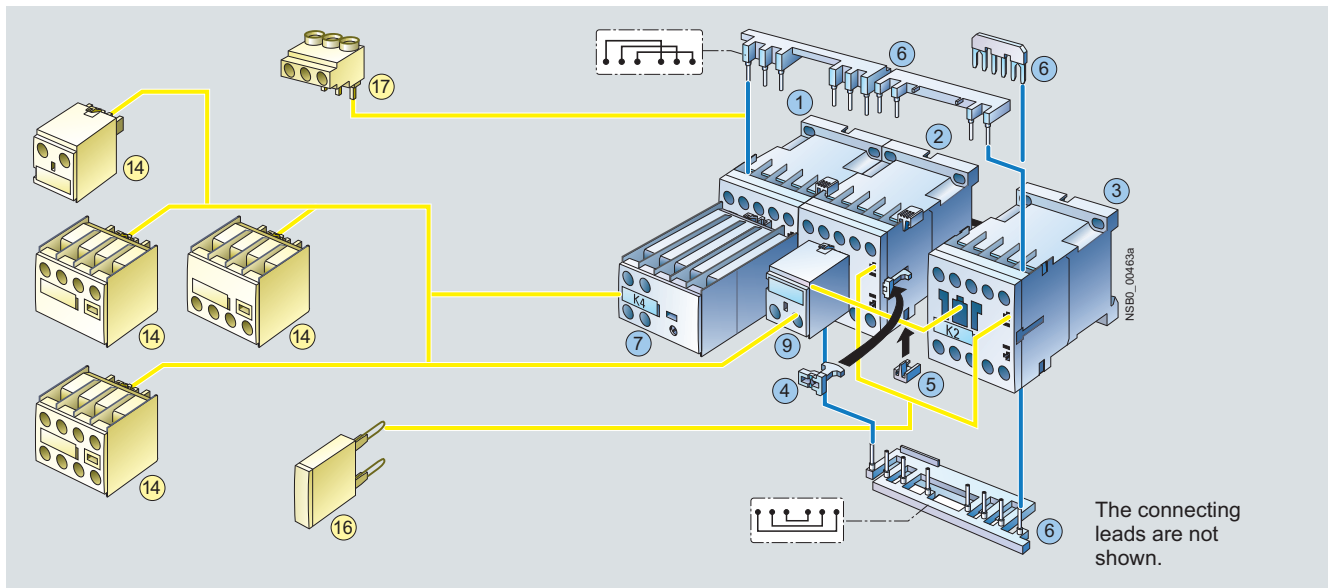

Mountable accessories (optional)

To be ordered separately	Order No.	Page
14 Auxiliary switch block, front	3RH19 11-1...	3/35
16 Surge suppressor	3RT19 16-1...	3/43
17 Three-phase feeder terminal	3RA19 13-3K	3/74

Complete contactor assemblies

Individual parts	Order No. K1 ¹⁾	K3 ²⁾	K2 ²⁾	Page
1 2 3 Contactor, 5.5 kW	3RT10 15	3RT10 15	3RT10 15	3/15
1 2 3 Contactor, 7.5 kW	3RT10 17	3RT10 17	3RT10 15	3/15
7 Solid-state time-delay auxiliary switch block, front	3RT19 16-2G.51			3/41
9 Auxiliary switch block with 1 unassigned NO contact	3RH19 11-1BA10			3/35
4 5 6 Assembly kit	3RA19 13-2B			3/74

The assembly kit contains:

- 4 Mechanical interlock
- 5 3 connecting clips
- 6 Wiring modules on the top and bottom for connecting the main and control conducting paths

1) Use version with 1 NO.
2) Use version with 1 NC.

Contactor Assemblies

3RA13, 3RA14 Contactor Assemblies

SIRIUS 3RA14 contactor assemblies for wye-delta starting

Fully wired and tested contactor assemblies · Size S0-S0-S0 · up to 18.5 kW



3RA14 2.-8XC21-1...

Rated data AC-3		Rated control supply voltage U_s ¹⁾			DT	Screw terminals	PU (UNIT, SET, M)	PS*	PG	
Operational current I_e up to	Ratings of induction motors at 50 Hz and					Order No.	Price € per PU			
400 V	230 V	400 V	500 V	690 V						
A	kW	kW	kW	kW	V					
AC operation, 50/60 Hz										
25	7,1	11	15,6	19	24 AC 110 AC 230 AC	B B ▶	3RA14 23-8XC21-1AC2 3RA14 23-8XC21-1AG2 3RA14 23-8XC21-1AL2	1 1 1	1 unit 1 unit 1 unit	41B 41B 41B
32 / 40	11,4	15 / 18,5	19	19	24 AC 110 AC 230 AC	B B ▶	3RA14 25-8XC21-1AC2 3RA14 25-8XC21-1AG2 3RA14 25-8XC21-1AL2	1 1 1	1 unit 1 unit 1 unit	41B 41B 41B
DC operation										
25	7,1	11	15,6	19	24 DC	▶	3RA14 23-8XC21-1BB4	1	1 unit	41B
32 / 40	11,4	15 / 18,5	19	19	24 DC	▶	3RA14 25-8XC21-1BB4	1	1 unit	41B

1) Coil operating range at 50 Hz: 0.8 ... 1.1 x U_s ; at 60 Hz: 0.85 ... 1.1 x U_s .

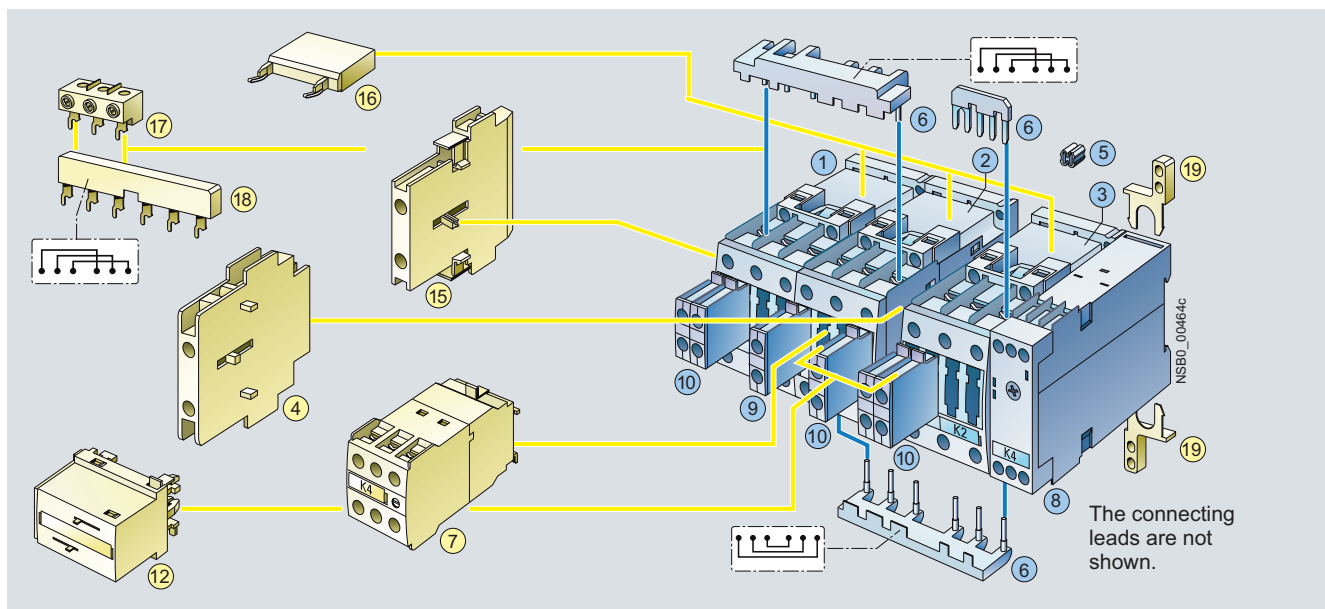

Mountable accessories (optional)

To be ordered separately	Order No.	Page
4 Mechanical interlock, lateral	3RA19 24-2B	3/64
7 Solid-state time-delay auxiliary switch block, front ¹⁾	3RT19 26-2G...	3/41
12 Mechanical interlock, front	3RA19 24-1A	3/64
15 Auxiliary switch block, lateral	3RH19 21-1EA..	3/39
16 Surge suppressor	3RT19 26-1...	3/43
17 Three-phase feeder terminal ²⁾	3RV19 15-5A	3/74
18 Three-phase busbar ²⁾	3RT19 26-4CC20	3/74
19 Push-in lug for screw mounting of timing relay ³⁾	3RP19 03	4)

Complete contactor assemblies

Individual parts	Order No. K1	K3	K2	Page
1 2 3 Contactor, 11 kW	3RT10 24	3RT10 24	3RT10 24	3/16
1 2 3 Contactor, 15/18.5 kW	3RT10 26	3RT10 26	3RT10 24	3/16
8 Timing relay, lateral	3RP15 74-1N.30			4)
9 Auxiliary switch block with 1 unassigned NO contact	3RH19 21-1CA10			3/38
10 Auxiliary switch block for local control				
- 2 units	3RH19 21-1CA01			
- 3 units	3RH19 21-1CA10			3/38
5 6 Assembly kit	3RA19 23-2B			3/74
The assembly kit contains:				
5 Connecting clips				
6 Wiring modules on the top and bottom for connecting the main and control conducting paths				

1) Generally possible. If a solid-state time-delay auxiliary switch block is mounted onto the front of K3, a standard auxiliary switch block can only be mounted onto the side.

2) 17 and 18 can only be mounted with contactors with screw terminal (coil).

3) Not included in the scope of supply of the preassembled contactor assemblies; can be ordered as an accessory.

4) See chapter 10 "Monitoring and Control Devices" → "3RP, 7PV Timing Relays" → "3RP15 Timing Relays in Industrial Enclosure, 22.5 mm".

Contactor Assemblies

3RA13, 3RA14 Contactor Assemblies

SIRIUS 3RA14 contactor assemblies for wye-delta starting

Fully wired and tested contactor assemblies · Size S2-S2-S0 · up to 30 kW



Rated data AC-3					Rated control supply voltage U_s ¹⁾	DT	Screw terminals		PU (UNIT, SET, M)	PS*	PG
Operational current I_e up to	Ratings of induction motors at 50 Hz and						Order No.	Price € per PU			
400 V	230 V	400 V	500 V	690 V							
A	kW	kW	kW	kW	V						
AC operation, 50/60 Hz											
50 / 65	19,6	22 / 30	35	34	24 AC	B	3RA14 34-8XC21-1AC2		1	1 unit	41B
					110 AC	B	3RA14 34-8XC21-1AG2		1	1 unit	41B
					230 AC	▶	3RA14 34-8XC21-1AL2		1	1 unit	41B
DC operation											
50 / 65	19,6	22 / 30	35	34	24 DC	▶	3RA14 34-8XC21-1BB4		1	1 unit	41B

3RA14 34-8XC21-1...

¹⁾ Coil operating range at 50 Hz: 0,8 ... 1.1 x U_s ; at 60 Hz: 0,85 ... 1.1 x U_s .

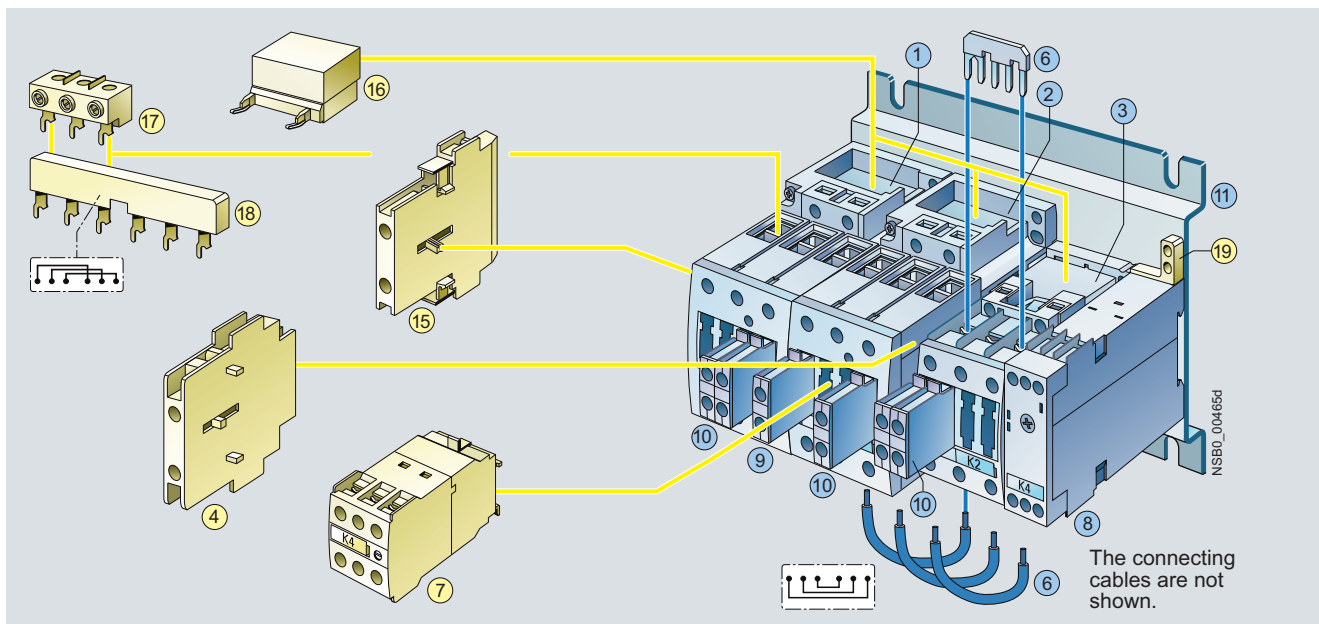

Mountable accessories (optional)		
To be ordered separately	Order No.	Page
4) Mechanical interlock, lateral. Depth compensation required: K3: 1.5 mm; K2: 0 mm ¹⁾	3RA19 24-2B	3/64
7) Solid-state time-delay auxiliary switch block, front ²⁾	3RT19 26-2G...	3/41
15) Auxiliary switch block, lateral	3RH19 21-1EA..	3/39
16) Surge suppressor	3RT19 26-1.... 3RT19 36-1....	3/43, 3/44
17) Three-phase feeder terminal	3RV19 35-5A	3/74
18) Three-phase busbar	3RV19 35-1A	3/74
19) Push-in lug for screw mounting of timing relay	3RP19 03	4)

Complete contactor assemblies				
Individual parts	Order No.			Page
	K1	K3	K2	
1) 2) 3) Contactor, 22/30 kW	3RT10 34	3RT10 34	3RT10 26	3/16
8) Timing relay, lateral	3RP15 74-1N.30			3)
9) Auxiliary switch block with 1 unassigned NO contact	3RH19 21-1CA10			3/38
10) Auxiliary switch block for local control	- 2 units			3/38
	- 3 units			3/38
11) Base plate	3RA19 32-2E			3/74
6) Assembly kit	3RA19 33-2C			3/74

The assembly kit contains the star jumper on the top and the wiring module on the bottom for connecting the main current paths.

¹⁾ Use the 3RA19 32-2B base plate for this configuration.
²⁾ Generally possible. If a solid-state time-delay auxiliary switch block is mounted onto the front of K3, a standard auxiliary switch block can only be mounted onto the side.
³⁾ See chapter 10 "Monitoring and Control Devices" → "3RP, 7PV Timing Relays" → "3RP15 Timing Relays in Industrial Enclosure, 22.5 mm".

Contactor Assemblies

3RA13, 3RA14 Contactor Assemblies

SIRIUS 3RA14 contactor assemblies for wye-delta starting

Fully wired and tested contactor assemblies · Size S2-S2-S2 · up to 45 kW



3RA14 3...8XC21-1...

Rated data AC-3					Rated control supply voltage U_s ¹⁾	DT	Screw terminals	PU (UNIT, SET, M)	PS*	PG	
Operational current I_e up to	Ratings of induction motors at 50 Hz and										
400 V	230 V	400 V	500 V	690 V			Order No.	Price € per PU			
A	kW	kW	kW	kW	V						
AC operation, 50/60 Hz											
80	25	37	51	63	24 AC	B	3RA14 35-8XC21-1AC2		1	1 unit	41B
					110 AC	B	3RA14 35-8XC21-1AG2		1	1 unit	41B
					230 AC	▶	3RA14 35-8XC21-1AL2		1	1 unit	41B
86	27	45	55	63	24 AC	B	3RA14 36-8XC21-1AC2		1	1 unit	41B
					110 AC	B	3RA14 36-8XC21-1AG2		1	1 unit	41B
					230 AC	▶	3RA14 36-8XC21-1AL2		1	1 unit	41B
DC operation											
80	25	37	51	63	24 DC	B	3RA14 35-8XC21-1BB4		1	1 unit	41B
86	27	45	55	63	24 DC	B	3RA14 36-8XC21-1BB4		1	1 unit	41B

¹⁾ Coil operating range at 50 Hz: 0,8 ... 1.1 x U_s ; at 60 Hz: 0,85 ... 1.1 x U_s .

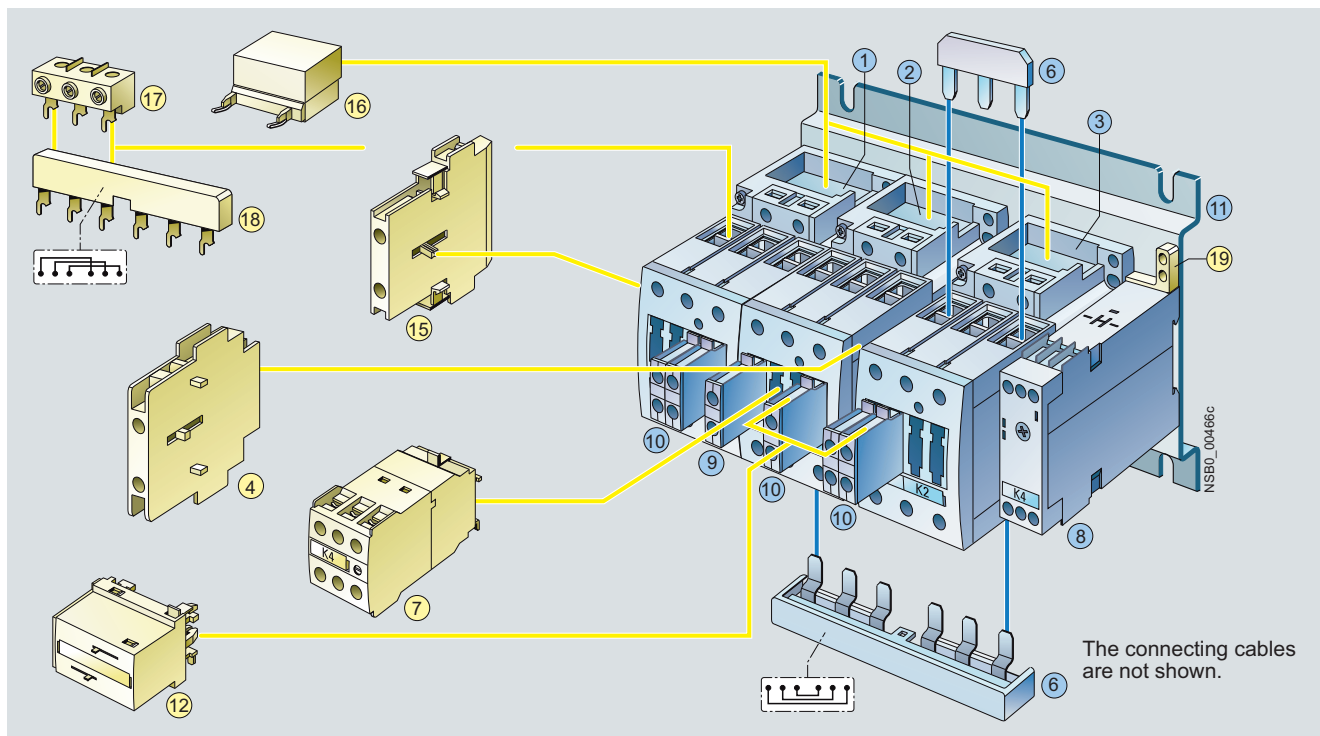

The connecting cables are not shown.

Mountable accessories (optional)		
To be ordered separately	Order No.	Page
4	Mechanical interlock, lateral	3RA19 24-2B 3/64
7	Solid-state time-delay auxiliary switch block, front ¹⁾	3RT19 26-2G... 3/41
12	Mechanical interlock, front	3RA19 24-1A 3/64
15	Auxiliary switch block, lateral	3RH19 21-1EA... 3/39
16	Surge suppressor	3RT19 26-1... 3/43, 3RT19 36-1... 3/44
17	Three-phase feeder terminal	3RV19 35-5A 3/74
18	Three-phase busbar	3RV19 35-1A 3/74
19	Push-in lug for screw mounting of timing relay	3RP19 03 2)

Complete contactor assemblies				
Individual parts	Order No.			Page
	K1	K3	K2	
1 2 3	Contactor, 37 kW	3RT10 35	3RT10 35	3RT10 34 3/17
1 2 3	Contactor, 45 kW	3RT10 36	3RT10 36	3RT10 34 3/17
8	Timing relay, lateral	3RP15 74-1N.30		2)
9	Auxiliary switch block with 1 unassigned NO contact	3RH19 21-1CA10		3/38
10	Auxiliary switch block for local control	- 2 units	3RH19 21-1CA01	3/38
		- 3 units	3RH19 21-1CA10	3/38
11		Base plate	3RA19 32-2F	3/74
6	Assembly kit	3RA19 33-2B		3/74

The assembly kit contains the star jumper on the top and the wiring module on the bottom for connecting the main current paths.

¹⁾ Generally possible. If a solid-state time-delay auxiliary switch block is mounted onto the front of K3, a standard auxiliary switch block can only be mounted onto the side.

²⁾ See chapter 10 "Monitoring and Control Devices" → "3RP, 7PV Timing Relays" → "3RP15 Timing Relays in Industrial Enclosure, 22.5 mm".

Contactor Assemblies

3RA13, 3RA14 Contactor Assemblies

SIRIUS 3RA14 contactor assemblies for wye-delta starting

Fully wired and tested contactor assemblies · Size S3-S3-S2 · up to 75 kW



Rated data AC-3					Rated control supply voltage U_s ¹⁾	DT	Screw terminals		PU (UNIT, SET, M)	PS*	PG	
Operational current I_e up to	Ratings of induction motors at 50 Hz and						Order No.	Price € per PU				
400 V	230 V	400 V	500 V	690 V								
A	kW	kW	kW	kW	V							
AC operation, 50/60 Hz												
115	37	55	81	93	24 AC	B	3RA14 44-8XC21-1AC2		1	1 unit	41B	
					110 AC	B	3RA14 44-8XC21-1AG2		1	1 unit	41B	
					230 AC	▶	3RA14 44-8XC21-1AL2		1	1 unit	41B	
150	47	75	103	110	24 AC	B	3RA14 45-8XC21-1AC2		1	1 unit	41B	
					110 AC	B	3RA14 45-8XC21-1AG2		1	1 unit	41B	
					230 AC	▶	3RA14 45-8XC21-1AL2		1	1 unit	41B	
DC operation												
3RA14 4...8XC21-1...	115	37	55	81	93	24 DC	B	3RA14 44-8XC21-1BB4		1	1 unit	41B
	150	47	75	103	110	24 DC	B	3RA14 45-8XC21-1BB4		1	1 unit	41B

¹⁾ Coil operating range at 50 Hz: 0,8 ... 1.1 x U_s ; at 60 Hz: 0,85 ... 1.1 x U_s .

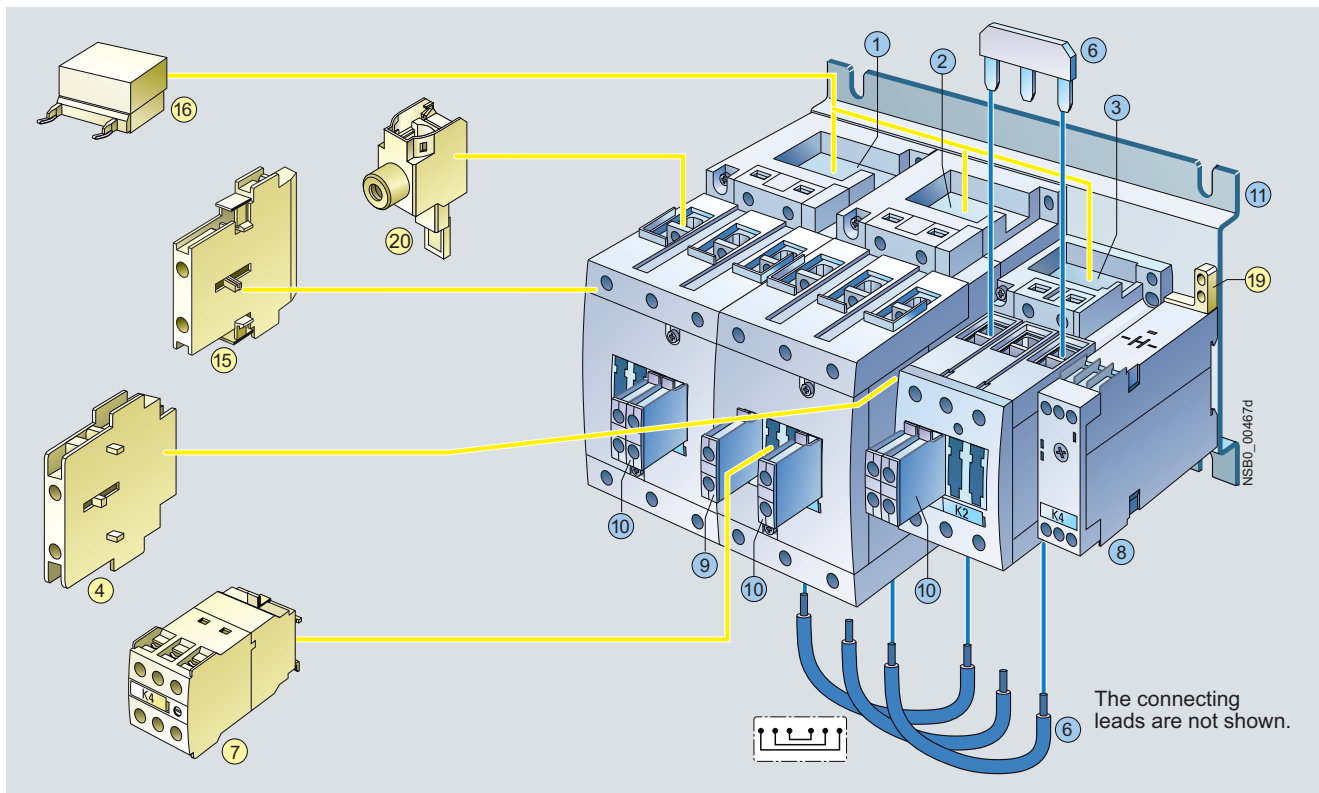

The connecting leads are not shown.

Mountable accessories (optional)

To be ordered separately	Order No.	Page
4 Mechanical interlock, lateral. Depth compensation required: K3: 0 mm; K2: 27.5 mm ¹⁾	3RA19 24-2B	3/64
7 Solid-state time-delay auxiliary switch block, front ²⁾	3RT19 26-2G...	3/41
15 Auxiliary switch block, lateral	3RH19 21-1EA...	3/39
16 Surge suppressors	3RT19 .6-1....	3/44
19 Push-in lug for screw mounting of timing relay	3RP19 03	3)
20 Single-phase feeder terminal	3RA19 43-3L	3/74

Complete contactor assemblies

Individual parts	Order No.			Page
	K1	K3	K2	
1 2 3 Contactor, 55 kW	3RT10 44	3RT10 44	3RT10 35	3/17
1 2 3 Contactor, 75 kW	3RT10 45	3RT10 45	3RT10 36	3/17
8 Timing relay, lateral	3RP15 74-1N.30			3)
9 Auxiliary switch block with 1 unassigned NO contact	3RH19 21-1CA10			3/38
10 Auxiliary switch block for local control				
- 2 units	3RH19 21-1CA01			3/38
- 3 units	3RH19 21-1CA10			3/38
11 Base plate	3RA19 42-2E			3/74
6 Assembly kit	3RA19 43-2C			3/74

The assembly kit contains the star jumper on the top and the wiring module on the bottom for connecting the main current paths.

¹⁾ Use the 3RA19 42-2B base plate for this configuration.
²⁾ Generally possible. If a solid-state time-delay auxiliary switch block is mounted onto the front of K3, a standard auxiliary switch block can only be mounted onto the side.

³⁾ See chapter 10 "Monitoring and Control Devices" → "3RP, 7PV Timing Relays" → "3RP15 Timing Relays in Industrial Enclosure, 22.5 mm".

Contactors Assemblies

3RA13, 3RA14 Contactor Assemblies

SIRIUS 3RA14 contactor assemblies for wye-delta starting

Components for customer assembly

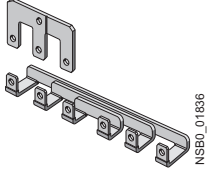
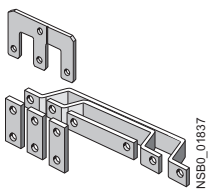
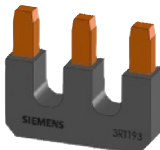
Version	Size	DT	Order No.	Price € per PU	PU (UNIT, SET, M)	PS*	PG
Assembly Kits							
The assembly kit contains: Mechanical interlock; 3 connecting clips, star jumper, wiring modules on the top and bottom	S00-S00-S00	▶	3RA19 13-2B		1	1 unit	41B
The assembly kit contains: 5 connecting clips, star jumper, wiring modules on the top and bottom	S0-S0-S0	▶	3RA19 23-2B		1	1 unit	41B
The assembly kit contains: Star jumper, wiring module on the bottom (Wiring module on the top is not included in the scope of supply.) (A double infeed between the line contactor and the delta contactor is recommended.)	S2-S2-S0 S2-S2-S2 S3-S3-S2 S3-S3-S3 S6-S6-S6 S6-S6-S6 S10-S10-S10 S12-S12-S12	▶ ▶ ▶ ▶ A A A B	3RA19 33-2C 3RA19 33-2B 3RA19 43-2C 3RA19 43-2B 3RA19 53-2B 3RA19 53-2N 3RA19 63-2B 3RA19 73-2B		1 1 1 1 1 1 1 1	1 unit 1 unit 1 unit 1 unit 1 unit 1 unit 1 unit 1 unit	41B 41B 41B 41B 41B 41B 41B 41B
 NSBU_01636							
3RA19 53-2B							
 NSBU_01637							
3RA19 53-2N, 3RA19 63-2B, 3RA19 73-2B							
Single-phase feeder terminals							
Conductor cross-section: 95 mm ²	S3	A	3RA19 43-3L		1	1 unit	41B
Three-phase feeder terminal							
Feeder terminal block for the line contactor for large conductor cross-sections							
Conductor cross-section: 6 mm ²	S00	▶	3RA19 13-3K		1	1 unit	41B
Conductor cross-section: 25 mm ²	S0	▶	3RV19 25-5AB		1	1 unit	41E
Conductor cross-section: 50 mm ²	S2	▶	3RV19 35-5A		1	1 unit	41E
Three-phase busbars							
Bridging phase-by-phase of all input terminals of the line contactor (K1) and the delta contactor (K3)	S0 S2	D ▶	3RT19 26-4CC20 3RV19 35-1A		1 1	1 unit 1 unit	41B 41E
Links for paralleling, 3-pole (star jumpers)							
Without terminal (The links for paralleling can be reduced by one pole)	S00 S0 S2 S3 S6¹⁾ S10, S12¹⁾	▶ ▶ ▶ ▶ ▶ ▶	3RT19 16-4BA31 3RT19 26-4BA31 3RT19 36-4BA31 3RT19 46-4BA31 3RT19 56-4BA31 3RT19 66-4BA31		1 1 1 1 1 1	1 unit 1 unit 1 unit 1 unit 1 unit 1 unit	41B 41B 41B 41B 41B 41B
 SIEMENS 3RT19							
3RT19 36-4BA31							
Base plates							
For customer assembly of contactor assemblies for wye-delta starting with timing relay mounted on the side							
Side-by-side mounting	S2, S2, S0	B	3RA19 32-2E		1	1 unit	41B
10 mm distance between K3 and K2	S2, S2, S2	B	3RA19 32-2F		1	1 unit	41B
Side-by-side mounting	S3, S3, S2	B	3RA19 42-2E		1	1 unit	41B
10 mm distance between K1, K3 and K2	S6, S6, S3 S6, S6, S6 S10, S10, S6 S10, S10, S10 S12, S12, S10 S12, S12, S12	B B B B B B	3RA19 52-2E 3RA19 52-2F 3RA19 62-2E 3RA19 62-2F 3RA19 72-2E 3RA19 72-2F		1 1 1 1 1 1	1 unit 1 unit 1 unit 1 unit 1 unit 1 unit	41B 41B 41B 41B 41B 41B
For customer assembly of contactor assemblies for wye-delta starting with a timing relay mounted on the front							
10 mm distance between K1, K3 and K2	S2, S2, S0 S2, S2, S2 S3, S3, S2	B B B	3RA19 32-2B 3RA19 32-2B 3RA19 42-2B		1 1 1	1 unit 1 unit 1 unit	41B 41B 41B

¹⁾ The 3RT19 56-4EA1 (S6) or 3RT19 66-4EA1 (S10, S12) cover can be used for touch protection.

Controls – Contactors and Contactor Assemblies – Special Applications

4



Price Groups

PG 41B

4/2

Introduction

Contactors for Special Applications

- 4/4 SIRIUS 3RT14 contactors for resistive loads (AC-1), 3-pole, 140 ... 690 A
- 4/6 SIRIUS 3RT13 contactors for resistive loads (AC-1), 4-pole, 4 NO, 18 ... 140 A
- 4/8 SIRIUS 3RT15 contactors, 4-pole, 2 NO + 2 NC, 4 ... 18.5 kW
- 4/10 SIRIUS 3RT16 capacitor contactors, 12.5 ... 50 kvar
- Contactors with Extended Operating Range $0.7 \dots 1.25 \times U_s$ for Railway Applications
- 4/13 SIRIUS 3RT10 motor contactors, 5.5 ... 45 kW
- Ch.5 SIRIUS 3RH11 contactor relays

Coupling Contactors

- Ch.3 SIRIUS 3RT10 coupling contactors (interface), 3-pole, 3 ... 11 kW
- Ch.5 SIRIUS 3RH11 coupling contactors for switching auxiliary circuits, 4-pole

More information can be found on the Internet: see [the opening information, page 8](#)

Note:

Safety characteristics for contactors see Catalog IC 10 · 2012
 → "Appendix" → "Standards and Approvals" → "Overview"

Introduction

Overview



Size Type	S00 3RT13 1, 3RT15 1				S0 3RT13 2, 3RT15 2			
4-pole 3RT13, 3RT15 contactors								
Type	3RT13 16	3RT13 17	3RT15 16	3RT15 17	3RT13 25	3RT13 26	3RT15 26	
Number of main contacts	4 NO		2 NO + 2 NC		4 NO		2 NO + 2 NC	
AC, DC operation	(p. 4/6, 4/7)		(p. 4/9)		(p. 4/6, 4/7)		(p. 4/9)	
-1 AC								
I_e at 400 V	A	18 / 16	22 / 20	18 / 16	22 / 20	35 / 30	40 / 35	40 / 35
40 °C	kW	12	14,5	11	13	22	26	26
60 °C	kW	11	13	6,5	7,5	20	23	15
AC-2 and AC-3								
I_e at 400 V	A	9	12	9	12	17	25	25
400 V	kW	4	5,5	4	5,5	7,5	11	11
230 V	kW	3	3	3	3	4	5,5	5,5
Accessories for contactors								
Auxiliary switch blocks	On front	3RH19 11		(Chap. 3)		3RH19 21		(Chap. 3)
	Lateral	3RH19 11		(Chap. 3)		3RH19 21		(Chap. 3)
Timing relay blocks		3RT19 16		(Chap. 3)		3RT19 26		(Chap. 3)
Surge suppressors		3RT19 16		(Chap. 3)		3RT19 26		(Chap. 3)



Size Type	S2 3RT13 36, 3RT15 35		S3 3RT13 4.		S6, S10, S12 3RT14 5.					
4-pole 3RT13, 3RT15 contactors • 3-pole 3RT14 contactors										
Type	3RT13 36	3RT15 35	3RT13 44	3RT13 46	3RT14 46	3RT14 56	3RT14 66	3RT14 76		
Number of main contacts	4 NO		2 NO + 2 NC		4 NO		3 NO			
AC, DC operation	(p. 4/6, 4/7)		(p. 4/9)		(p. 4/6, 4/7)		(p. 4/4)			
AC-1 (≤ 690 V)										
I_e	40 °C	A	60	60	110	140	140	275	400	690
	60 °C	A	55	55	100	120	130	250	380	650
400 V	40 °C	kW	39	36	72	92	92	180	263	454
230 V	40 °C	kW	23	20	42	53	53	105	151	261
500 V		kW	--	--	--	--	115	225	329	568
690 V		kW	--	--	--	--	159	310	454	783
1000 V	60 °C	kW	--	--	--	--	98	165	247	410
AC-2 and AC-3										
I_e /AC-3/400 V	A					44	97	138	170	
400 V	kW	11	18,5			22	55	75	90	
230 V	kW	5,5	9,5	--	--	12,7	30	37	55	
500 V	kW	--	--	--	--	29,9	55	90	110	
690 V	kW	--	--	--	--	38,2	90	132	160	
Accessories for contactors										
Auxiliary switch blocks	On front	3RH19 21		(Chap. 3)						
	Lateral	3RH19 21		(Chap. 3)						
Terminal covers		3RT19 36-4EA4		(Chap. 3)		3RT19 46-4EA4		(Chap. 3)	3RT19 56-4EA1/2/3	(Chap. 3)
Box terminal blocks		--		--					3RT19 55/56/66-4G	(Chap. 3)
Surge suppressors		3RT19 26/36		(Chap. 3)					3RT19 56-1C	(Chap. 3)

Note:

Safety characteristics for contactors see
Catalog IC 10 · 2012, "Appendix" → "Standards and Approvals"
→ "Overview"

Connection methods

The contactors are available with screw terminals (box terminals or flat connectors) or with spring-type terminals.



Screw terminals



Spring-type terminals

The terminals are indicated in the corresponding tables by the symbols shown on orange backgrounds.

Contactors for Special Applications

SIRIUS 3RT14 contactors for resistive loads (AC-1), 3-pole, 140 ... 690 A

Overview

Standards

IEC 60947-1, EN 60947-1,
IEC 60947-4-1, EN 60947-4-1,
IEC 60947-5-1, EN 60947-5-1 (auxiliary switches)

The contactors are suitable for use in any climate. They are finger-safe according to EN 50274.

3RT14 contactors are used for switching resistive loads (AC-1) or as contactors, for example for variable-speed operating mechanisms that normally only have to carry the current.

Size S3: AC or DC operation

Sizes S6 to S12: AC/DC operation

The following applies for sizes S6 to S12:

- Withdrawable coils
- Coils with integrated surge suppression (varistor)
- Main conductors: Busbar connections
- Auxiliary and control conductors: Screw terminals

The accessories for the 3RT10 contactors can also be used here.

General descriptions of the sizes S3 to S12 see Chapter 3, "SIRIUS 3RT10 Contactors, 3-pole, 3 to 250 kW".

Selection and ordering data

Size S3: AC or DC operation



3RT14 46-1A..0

Size	Rated data AC-1, $T_u: 40^\circ\text{C}$	Auxiliary contacts	Rated control supply voltage U_s	DT	Screw terminals	PU (UNIT, SET, M)	PS*	PG
	Operational current I_e	Version			Order No.	Price € per PU		
	Rating of AC loads (p f. = 0.95) at	NO NC V						
Up to 690 V A	230 V kW	400 V kW	500 V kW	690 V kW				

For screw and snap-on mounting onto
TH 35 and TH 75 standard mounting rail

AC operation

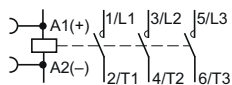

S3	140	53	92	115	159	--	--	AC 24, 50 Hz B	3RT14 46-1AB00	1	1 unit	41B
								AC 110, 50 Hz B	3RT14 46-1AF00	1	1 unit	41B
								AC 230, 50 Hz ▶	3RT14 46-1AP00	1	1 unit	41B

DC operation · DC solenoid system

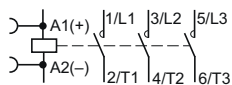

S3	140	53	92	115	159	--	--	24 DC	▶ 3RT14 46-1BB40	1	1 unit	41B
								220 DC	B 3RT14 46-1BM40	1	1 unit	41B

Other voltages according to page 4/12 on request.

Accessories and spare parts see "3RT10 Contactors",
Chapter 3.

SIRIUS 3RT14 contactors for resistive loads (AC-1), 3-pole, 140 ... 690 A

Sizes S6 to S12: UC operation (AC/DC)
Coils with integrated surge suppression (varistor)
Main conductors: Busbar connections
Auxiliary and control conductors: Screw terminals



3RT14 6.

Size	Rated data AC-1, $T_U: 40\text{ °C}$				Auxiliary contacts		Rated control supply voltage U_s	DT	Screw terminals	PU (UNIT, SET, M)	PS*	PG
	Operational current I_e	Rating of AC loads (p f. = 0.95) at				Version						
Up to 690 V	A	230 V	400 V	500 V	690 V	NO	NC	V	Order No.	Price € per PU		
		kW	kW	kW	kW							

Conventional operating mechanisms

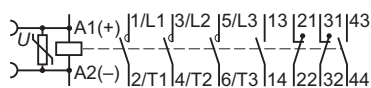

S6	275	105	180	225	310	2	2	110 ... 127 220 ... 240	▶	3RT14 56-6AF36 3RT14 56-6AP36	1 1	1 unit 1 unit	41B 41B
S10	400	151	263	329	454	2	2	110 ... 127 220 ... 240	▶	3RT14 66-6AF36 3RT14 66-6AP36	1 1	1 unit 1 unit	41B 41B
S12	690	261	454	568	783	2	2	110 ... 127 220 ... 240	A ▶	3RT14 76-6AF36 3RT14 76-6AP36	1 1	1 unit 1 unit	41B 41B

Solid-state operating mechanism

For 24 V DC PLC output

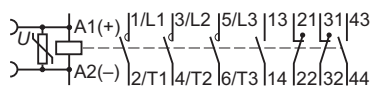

S6	275	105	180	225	310	2	2	96 ... 127 200 ... 277	B ▶ A	3RT14 56-6NF36 3RT14 56-6NP36	1 1	1 unit 1 unit	41B 41B
S10	400	151	263	329	454	2	2	96 ... 127 200 ... 277	B ▶ A	3RT14 66-6NF36 3RT14 66-6NP36	1 1	1 unit 1 unit	41B 41B
S12	690	261	454	568	783	2	2	96 ... 127 200 ... 277	B ▶ A	3RT14 76-6NF36 3RT14 76-6NP36	1 1	1 unit 1 unit	41B 41B

For 24 V DC PLC relay output, with remaining lifetime indicator (RLT)

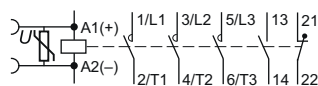

S6	275	105	180	225	310	1	1	96 ... 127 200 ... 277	B ▶ B	3RT14 56-6PF35 3RT14 56-6PP35	1 1	1 unit 1 unit	41B 41B
S10	400	151	263	329	454	1	1	200 ... 277	B ▶	3RT14 66-6PP35	1	1 unit	41B
S12	690	261	454	568	783	1	1	200 ... 277	B ▶	3RT14 76-6PP35	1	1 unit	41B

With AS-Interface interface and remaining lifetime indicator (RLT)

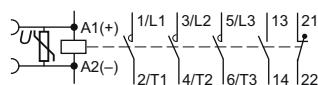

S6	275	105	180	225	310	1	1	96 ... 127 200 ... 277	B ▶ B	3RT14 56-6QF35 3RT14 56-6QP35	1 1	1 unit 1 unit	41B 41B
S10	400	151	263	329	454	1	1	200 ... 277	B ▶	3RT14 66-6QP35	1	1 unit	41B
S12	690	261	454	568	783	1	1	200 ... 277	B ▶	3RT14 76-6QP35	1	1 unit	41B

Other voltages according to page 4/12 on request.

Accessories and spare parts see "3RT10 Contactors", Chapter 3.

Contactors for Special Applications

SIRIUS 3RT13 contactors for resistive loads (AC-1), 4-pole, 4 NO, 18 ... 140 A

Overview

Standards

IEC 60947-1, EN 60947-1,
IEC 60947-4-1, EN 60947-4-1,
IEC 60947-5-1, EN 60947-5-1 (auxiliary switches)

The contactors are suitable for use in any climate. They are finger-safe according to EN 50274.

3RT13 contactors are used for switching resistive loads (AC-1) but are also suitable for switching mixed loads in distribution systems (e. g. for supplying heaters, lamps, motors, PC power supply units) with p.f. > 0.8 according to IEC 60947-4-1, test conditions for utilization category AC-1.

Accessories

The accessories for the 3-pole SIRIUS 3RT10 contactors can also be used for the 4-pole versions (see Chapter 3).

Auxiliary switches

Size S00: Snap-on auxiliary switch blocks according to EN 50005.

Sizes S0 to S3: Snap-on auxiliary switch blocks according to EN 50012 and EN 50005 (for S0 max. 2 auxiliary contacts).

Selection and ordering data

AC operation, 4 NO contacts

PU (UNIT, SET, M) = 1
PS* = 1 unit
PG = 41B



3RT13 3.-1A.00



3RT13 1.-1A.00



3RT13 1.-2A.00

Rated data AC-1, T_{ij} : 40/60 °C	Rated control supply voltage U_s	DT	Screw terminals	DT	Spring-type terminals	
Operational current I_e	Ratings of AC loads (p.f. = 0.95) at 50 Hz and 400 V		Order No.	Price € per PU	Order No.	Price € per PU
A	kW	V AC				

For screw and snap-on mounting onto TH 35 standard mounting rail

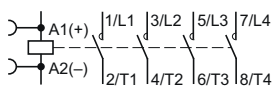

Size S00¹⁾

18 / 16	12 / 11	24, 50/60 Hz 110, 50/60 Hz 230, 50/60 Hz	▶	3RT13 16-1AB00 3RT13 16-1AF00 3RT13 16-1AP00	B B B	3RT13 16-2AB00 3RT13 16-2AF00 3RT13 16-2AP00
22 / 20	14,5 / 13	24, 50/60 Hz 110, 50/60 Hz 230, 50/60 Hz	▶	3RT13 17-1AB00 3RT13 17-1AF00 3RT13 17-1AP00	B B B	3RT13 17-2AB00 3RT13 17-2AF00 3RT13 17-2AP00

Size S0²⁾

35 / 30	22 / 20	24, 50 Hz 110, 50 Hz 230, 50 Hz	▶	3RT13 25-1AB00 3RT13 25-1AF00 3RT13 25-1AP00	---	---
40 / 35	26 / 23	24, 50 Hz 110, 50 Hz 230, 50 Hz	▶	3RT13 26-1AB00 3RT13 26-1AF00 3RT13 26-1AP00	---	---

Size S2

60 / 55	39 / 36	24, 50 Hz 110, 50 Hz 230, 50 Hz	B B ▶	3RT13 36-1AB00 3RT13 36-1AF00 3RT13 36-1AP00	---	---
---------	----------------	---------------------------------------	-------------	---	-----	-----

Size S3

110 / 100	72 / 66	24, 50 Hz 110, 50 Hz 230, 50 Hz	B B ▶	3RT13 44-1AB00 3RT13 44-1AF00 3RT13 44-1AP00	---	---
140 / 120	92 / 79	24, 50 Hz 110, 50 Hz 230, 50 Hz	B B ▶	3RT13 46-1AB00 3RT13 46-1AF00 3RT13 46-1AP00	---	---

Other voltages according to page 4/12 on request.

Accessories and spare parts see "3RT10 Contactors", Chapter 3.

¹⁾ For size S00: Coil operating range at 50 Hz: 0,8 ... 1.1 x U_s , at 60 Hz: 0,85 ... 1.1 x U_s .

²⁾ Minimum conductor cross-section 10 mm².

SIRIUS 3RT13 contactors for resistive loads (AC-1), 4-pole, 4 NO, 18 ... 140 A

DC operation - DC solenoid system, 4 NO contacts

PU (UNIT, SET, M) = 1
 PS* = 1 unit
 PG = 41B



3RT13 4.-1B..40



3RT13 1.-1B.40



3RT13 1.-2B.40

Rated data AC-1, T_U : 40/60 °C	Rated control supply voltage U_c	DT	Screw terminals	DT	Spring-type terminals	
Operational current I_e	Ratings of AC loads (p.f. = 0.95) at 50 Hz and 400 V		Order No.	Price € per PU	Order No.	Price € per PU
A	kW	V DC				

For screw and snap-on mounting onto TH 35 standard mounting rail

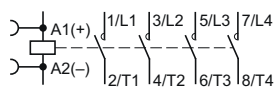

Size S00

18 / 16	12 / 11	24 220	▶ B	3RT13 16-1BB40 3RT13 16-1BM40	▶ B	3RT13 16-2BB40 3RT13 16-2BM40
22 / 20	14,5 / 13	24 220	▶ B	3RT13 17-1BB40 3RT13 17-1BM40	A B	3RT13 17-2BB40 3RT13 17-2BM40

Size S0¹⁾

35 / 30	22 / 20	24 220	▶ B	3RT13 25-1BB40 3RT13 25-1BM40	▶ B	---
40 / 35	26 / 23	24 220	▶ B	3RT13 26-1BB40 3RT13 26-1BM40	▶ B	---

Size S2

60 / 55	39 / 36	24 220	▶ B	3RT13 36-1BB40 3RT13 36-1BM40	▶ B	---
---------	----------------	-----------	--------	--	--------	-----

Size S3

110 / 100	72 / 66	24 220	B	3RT13 44-1BB40 3RT13 44-1BM40	B	---
140 / 120	92 / 79	24 220	B	3RT13 46-1BB40 3RT13 46-1BM40	B	---

Other voltages according to page 4/12 on request.

Accessories and spare parts see "3RT10 Contactors",
 Chapter 3.

¹⁾ Minimum conductor cross-section 10 mm².

Contactors for Special Applications

SIRIUS 3RT15 contactors, 4-pole, 2 NO + 2 NC, 4 ... 18.5 kW

Overview

Standards

IEC 60947-1, EN 60947-1,
IEC 60947-4-1, EN 60947-4-1

The contactors are suitable for use in any climate. They are finger-safe according to EN 50274.

Note:

Single device for pole reversal; not suitable for reversing duty. 3RT15 contactors are not suitable for switching a load between 2 current sources.

Accessories

The accessories for the 3-pole SIRIUS 3RT10 contactors can also be used for the 4-pole versions ([see Chapter 3](#)).

Auxiliary switches

Size S00: Snap-on auxiliary switch blocks according to EN 50005.

Sizes S0 to S3: Snap-on auxiliary switch blocks according to EN 50012 and EN 50005 (for S0 max. 2 auxiliary contacts).

Selection and ordering data

AC and DC operation, 2 NO contacts + 2 NC contacts¹⁾

PU (UNIT, SET, M) = 1
 PS* = 1 unit
 PG = 41B



3RT15 26-1A..0



3RT15 1.-1...0



3RT15 1.-2...0

Rated data		Rated control supply voltage U_s		DT	Screw terminals		DT	Spring-type terminals	
AC-2/AC-3, T_U : Up to 60 °C		AC-1, T_U : 40/60 °C							
Operational current I_e	Ratings of induction motors at 50 Hz and	Operational current I_e			Order No.	Price € per PU	Order No.	Price € per PU	
At 400 V	400 V								
A	kW	A	V						

For screw and snap-on mounting onto TH 35 standard mounting rail

AC operation

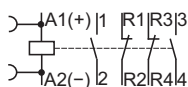

Size S00¹⁾

9	4	18 / 16	24, 50 Hz 110, 50 Hz 230, 50 Hz	B	3RT15 16-1AB00 3RT15 16-1AF00 3RT15 16-1AP00	B	3RT15 16-2AB00 3RT15 16-2AF00 3RT15 16-2AP00
12	5,5	22 / 20	24, 50 Hz 110, 50 Hz 230, 50 Hz	A	3RT15 17-1AB00 3RT15 17-1AF00 3RT15 17-1AP00	B	3RT15 17-2AB00 3RT15 17-2AF00 3RT15 17-2AP00

Size S0²⁾

25	11	40 / 35	24, 50 Hz 110, 50 Hz 230, 50 Hz	B	3RT15 26-1AB00 3RT15 26-1AF00 3RT15 26-1AP00	--	--
----	----	---------	---------------------------------------	---	--	----	----

Size S2

40	18,5	55 / 50	24, 50 Hz 110, 50 Hz 230, 50 Hz	B	3RT15 35-1AB00 3RT15 35-1AF00 3RT15 35-1AP00	--	--
----	------	---------	---------------------------------------	---	--	----	----

DC operation · DC solenoid system

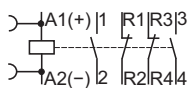

Size S00

9	4	18 / 16	24 DC 220 DC	B	3RT15 16-1BB40 3RT15 16-1BM40	B	3RT15 16-2BB40 3RT15 16-2BM40
12	5,5	22 / 20	24 DC 220 DC	B	3RT15 17-1BB40 3RT15 17-1BM40	B	3RT15 17-2BB40 3RT15 17-2BM40

Size S0²⁾

25	11	40 / 35	24 DC 220 DC	B	3RT15 26-1BB40 3RT15 26-1BM40	--	--
----	----	---------	-----------------	---	----------------------------------	----	----

Size S2

40	18,5	55 / 50	24 DC 220 DC	B	3RT15 35-1BB40 3RT15 35-1BM40	--	--
----	------	---------	-----------------	---	----------------------------------	----	----

¹⁾ For size S00: Coil operating range
 at 50 Hz: 0,8 ... 1.1 x U_s
 at 60 Hz: 0,85 ... 1.1 x U_s .

²⁾ Minimum conductor cross-section 10 mm².

Other voltages according to page 4/12 on request.

Accessories and spare parts see "3RT10 Contactors",
 Chapter 3.

Contactors for Special Applications

SIRIUS 3RT16 capacitor contactors, 12.5 ... 50 kvar

Overview

Standards

IEC 60947-1, EN 60947-1,
IEC 60947-4-1, EN 60947-4-1,
IEC 60947-5-1, EN 60947-5-1 (auxiliary switches)

The contactors are suitable for use in any climate. They are finger-safe according to EN 50274.

Function

The 3RT16 capacitor contactors are special versions of the 3RT10 contactors size S00 to S3. The capacitors are precharged by means of the mounted leading NO contacts and resistors; only then do the main contacts close.

This prevents disturbances in the network and welding of the contactors.

Only discharged capacitors are permitted to be switched on with capacitor contactors.

Capacitor switching capacity of the basic 3RT10 contactor version see ["Technical Information" on the Internet](#).

Auxiliary switches

The auxiliary switch block which is snapped onto the capacitor contactor contains the three leading NO contacts and in the case of S00 one standard NC contact and in the case of S0 and S3 one standard NO contact, which is unassigned. Size S00 also contains another unassigned NO contact in the basic unit.

In addition, a 2-pole auxiliary switch block can be mounted laterally on the 3RT16 47 capacitor contactors (2 NO, 2 NC or 1 NO + 1 NC versions); type 3RH19 21-1EA... The fitting of auxiliary switches for 3RT16 17 and 3RT16 27 is not expandable.

Circuit diagrams

Size S00

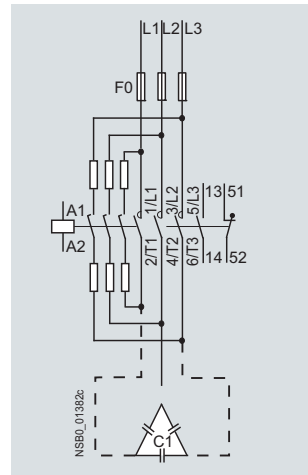

Sizes S0 and S3

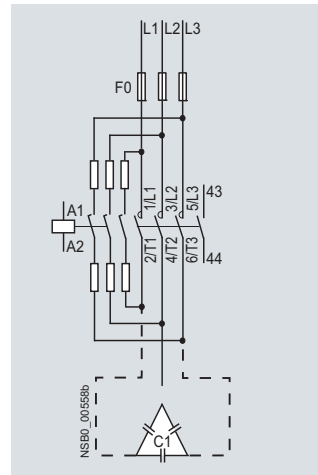

Selection and ordering data

AC operation

Screw terminals



3RT16 17-1A.03



3RT16 27-1A.01



3RT16 47-1A.01

Utilization category AC-6b Switching of AC capacitors for an ambient temperature of 60 °C ¹⁾ Capacitor rating at operational voltage 50/60 Hz				Auxiliary contacts, unassigned Version		Rated control supply voltage U_s ²⁾		DT	Screw terminals	⊕	PU (UNIT, SET, M)	PS*	PG
At 230 V	At 400 V	At 525 V	At 690 V	NO	NC	V AC	Hz	Order No.	Price € per PU				
kvar	kvar	kvar	kvar										

For screw and snap-on mounting onto TH 35 standard mounting rail

Size S00

3 ... 7,5	5 ... 12,5	7,5 ... 15	10 ... 21	1	1	24	50 / 60	B	3RT16 17-1AB03	1	1 unit	41B
						110		B	3RT16 17-1AF03	1	1 unit	41B
						230		▶	3RT16 17-1AP03	1	1 unit	41B

Size S0³⁾

3,5 ... 15	6 ... 25	7,8 ... 30	10 ... 42	1	--	24	50	B	3RT16 27-1AB01	1	1 unit	41B
						110		B	3RT16 27-1AF01	1	1 unit	41B
						230		▶	3RT16 27-1AP01	1	1 unit	41B

Size S3

3,5 ... 30	5 ... 50	7,5 ... 60	10 ... 84	1	--	24	50	B	3RT16 47-1AB01	1	1 unit	41B
						110		B	3RT16 47-1AF01	1	1 unit	41B
						230		▶	3RT16 47-1AP01	1	1 unit	41B

¹⁾ For size S3: 55 °C.

²⁾ Operating range: 0,85 ... 1.1 x U_s .

³⁾ For conductor cross-sections > 6 mm²
use 3RV19 25-5AB terminals (2 units).

Other voltages according to page 4/12 on request.

Accessories and spare parts see "3RT10 Contactors",
Chapter 3.

Contactors for Special Applications

SIRIUS 3RT1 contactors

Options

Rated control supply voltages, possible on request (the 10th and 11th position of the order number must be changed)

Rated control supply voltage U_s	Contactor type	3RT13 1, 3RT15 1	3RT13 2, 3RT15 2	3RT13 3, 3RT13 4, 3RT15 3	3RT14 4	3RT16 17, 3RT16 27, 3RT16 47
	Size	S00	S0	S2, S3	S3	S00, S0, S3

Sizes S00 to S3

AC operation

Solenoid coils for 50 Hz (exception: Size S00: 50 and 60 Hz¹⁾)

24 V AC	B0	B0	B0	B0	B0	B0
42 V AC	D0	D0	D0	D0	D0	--
48 V AC	H0	H0	H0	H0	H0	--
110 V AC	F0	F0	F0	F0	F0	F0
230 V AC	P0	P0	P0	P0	P0	P0
240 V AC	U0	U0	U0	U0	U0	U0
400 V AC	V0	V0	V0	V0	V0	V0

Solenoid coils for 50 and 60 Hz¹⁾

24 V AC	B0	C2	C2	C2	C2	C2
42 V AC	D0	D2	D2	D2	D2	--
48 V AC	H0	H2	H2	H2	H2	--
110 V AC	F0	G2	G2	G2	G2	G2
220 V AC	N2	N2	N2	N2	N2	N2
230 V AC	P0	L2	L2	L2	L2	L2
240 V AC	P2	P2	P2	P2	P2	P2

Solenoid coils (for USA and Canada²⁾)

50 Hz	60 Hz					
110 V AC	120 V AC	K6	K6	K6	K6	K6
220 V AC	240 V AC	P6	P6	P6	P6	P6

Solenoid coils (for Japan)

50/60 Hz ³⁾	60 Hz ⁴⁾					
100 V AC	110 V AC	G6	G6	G6	G6	G6
200 V AC	220 V AC	N6	N6	N6	N6	N6
400 V AC	440 V AC	R6	R6	R6	R6	R6

DC operation

12 V DC	A4	--	--	--	--	--
24 V DC	B4	B4	B4	B4	B4	--
42 V DC	D4	D4	D4	D4	D4	--
48 V DC	W4	--	W4	W4	W4	--
60 V DC	--	--	--	E4	--	--
110 V DC	F4	F4	F4	F4	F4	--
125 V DC	G4	G4	G4	G4	G4	--
220 V DC	M4	M4	M4	M4	M4	--
230 V DC	P4	--	P4	P4	P4	--

Examples

AC operation	3RT13 25-1AP00	Contactors with screw terminals; with solenoid coil for 50 Hz for rated control supply voltage 230 V AC.
	3RT13 25-1AG20	Contactors with screw terminals; with solenoid coil for 50/60 Hz for rated control supply voltage 110 V AC.
DC operation	3RT15 26-2BB40	Contactors with spring-type terminals; for rated control supply voltage 24 V DC.
	3RT15 26-2BG40	Contactors with spring-type terminals; for rated control supply voltage 125 V DC.

Rated control supply voltage	Contactor type	3RT14 56-6A..., 3RT14 66-6A..., 3RT14 76-6A...	Rated control supply voltage	Contactor type	3RT14 56-6N..., 3RT14 66-6N..., 3RT14 76-6N...	3RT14 56-6P/Q..., 3RT14 66-6P/Q..., 3RT14 76-6P/Q...
$U_{s \min} \dots U_{s \max}^{5)}$	Size	S00	$U_{s \min} \dots U_{s \max}^{5)}$	Size		

Size S6 to S12

UC operation (AC 40 to 60 Hz, DC)

23 ... 26 V AC/DC	B3	21 ... 27.3 V AC/DC	B3	--
42 ... 48 V AC/DC	D3	96 ... 127 V AC/DC	F3	F3
110 ... 127 V AC/DC	F3	200 ... 277 V AC/DC	P3	P3
200 ... 220 V AC/DC	M3			
220 ... 240 V AC/DC	P3			
240 ... 277 V AC/DC	U3			
380 ... 420 V AC/DC	V3			
440 ... 480 V AC/DC	R3			
500 ... 550 V AC/DC	S3			
575 ... 600 V AC/DC	T3			

¹⁾ Coil operating range
at 50 Hz: 0,8 ... 1,1 x U_s
at 60 Hz: 0,85 ... 1,1 x U_s .

²⁾ Coil operating range
Size S00: at 50 Hz: 0,85 ... 1,1 x U_s
at 60 Hz: 0,8 ... 1,1 x U_s
Size S0 to S3: at 50 Hz and 60 Hz: 0,8 ... 1,1 x U_s .

³⁾ Coil operating range
Size S00: at 50/60 Hz: 0,85 ... 1,1 x U_s
Size S0 to S3: at 50 Hz: 0,8 ... 1,1 x U_s
at 60 Hz: 0,85 ... 1,1 x U_s .

⁴⁾ Coil operating range
at 60 Hz: 0,8 ... 1,1 x U_s .

⁵⁾ Coil operating range: 0,7 x $U_{s \min}$... 1,3 x $U_{s \max}$.

Contactors with extended operating range $0.7 \dots 1.25 \times U_s$ for railway applications

**SIRIUS 3RT10 motor contactors,
5.5 ... 45 kW**

Overview

Standards

IEC 60947-4-1, EN 60947-4-1,
for requirements acc. to IEC 60077-1 and IEC 60077-2

The contactors are finger-safe according to EN 50274 (exception: series resistor S2 and S3).

The contactors are available with screw terminals or spring-type terminals. On sizes S0 to S3, only the auxiliary conductor terminals and coil terminals are spring-type terminals.

Control and auxiliary circuits

Contactors are available with:

- Conventional coils
- Coils with series resistor
- Coils with solid-state control unit

The solenoid coils of the contactors have an extended coil operating range from 0.7 to $1.25 \times U_s$ and are fitted as standard with varistors to provide protection against overvoltage. The opening delay is therefore 2 to 5 ms longer than for standard contactors.

Ambient temperature

The permissible ambient temperature for operation of the contactors (across the full coil operating range) is $-40 \text{ }^\circ\text{C}$ to $+70 \text{ }^\circ\text{C}$.

Uninterrupted duty at temperatures $> +60 \text{ }^\circ\text{C}$ reduces the mechanical endurance, the load rating capacity of the conducting paths and the switching frequency.

Application

For operation in installations which are subject both to considerable variations in the control voltage and to high ambient temperatures, e. g. railway applications under extreme climatic conditions, rolling mills, etc.

Sizes S00 and S0 with conventional coil

These contactor relays have an extended operating range from 0.7 to $1.25 \times U_s$; the coils are fitted with varistors as standard. An additional series resistor is not required.

Please note:

- Size S00: It is not possible to mount an auxiliary switch block.
- Size S0: Up to two single-pole auxiliary switch blocks can be mounted.

Mounting

A clearance of 10 mm is required for side-by-side mounting at ambient temperatures $> 60 \text{ }^\circ\text{C} \leq 70 \text{ }^\circ\text{C}$.

Sizes S00 to S3 with series resistor

The DC solenoid systems of the contactors are modified (to holding excitation) by means of a series resistor.

Auxiliary switches

The size S00 contactors are supplied prewired with a plug-on module containing the series resistor. The varistor is integrated. The integrated NC contact is used for switching the series resistor. A 4-pole auxiliary switch block (according to EN 50005) can be fitted additionally.

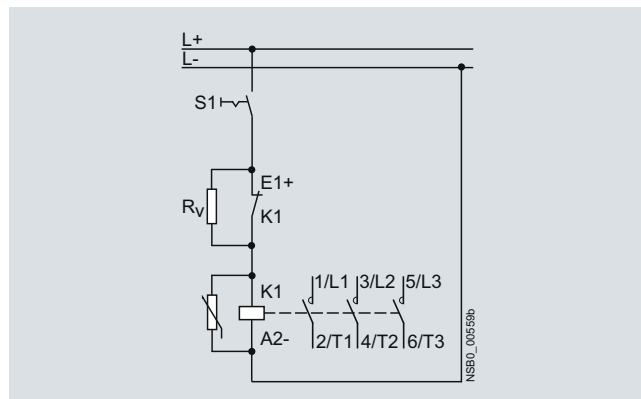

Circuit diagram with series resistor (size S00)

The size S0 to S3 contactors are equipped on the front with an auxiliary switch block with 2 NO + 2 NC contacts. The separate series resistor, which is attached laterally next to the contactor on the 35 mm standard mounting rail, is fitted with connecting cables for mounting onto contactors. A circuit diagram showing the terminals is stuck onto each contactor. The NC contact 21-22 of the auxiliary contacts is required for the series resistor function.

Mounting

At ambient temperatures up to $70 \text{ }^\circ\text{C}$, the size S00 contactors and contactor relays are allowed to be mounted side by side.

The resistor module of the size S0 to S3 contactors must be mounted to the left of the contactor owing to the prefabricated connecting cables.

Dimensions

Attaching the series resistor increases the width of contactor sizes S0 to S3.

Sizes S0 to S3 with solid-state control unit

The contactors are supplied as complete units with a built-on solid-state control unit.

Control and auxiliary circuits

The contactors are energized via upstream control electronics which ensure the coil operating range of 0.7 to $1.25 \times U_s$ at an ambient temperature of $70 \text{ }^\circ\text{C}$.

A varistor is integrated for damping opening surges in the coil. The opening delay is therefore 2 to 5 ms longer than for standard contactors.

The possibility of mounting auxiliary switches is the same as that for equivalent standard contactors.

Mounting

At ambient temperatures up to $70 \text{ }^\circ\text{C}$, sizes S0 to S3 of these contactor versions are allowed to be mounted side by side.

Dimensions

Because of the built-on solid-state control unit, the height of the size S0 to S3 contactors increases by up to 34 mm.

Contactors for Special Applications

Contactors with extended operating range 0.7 ... 1.25 x U_s for railway applications

SIRIUS 3RT10 motor contactors, 5.5 ... 45 kW

Selection and ordering data

DC operation · DC solenoid system

Conventional solenoid coil, fitted with varistor



3RT10 3.-2K.40

Rated data AC-2 and AC-3 T_U : 70 °C	Ratings of induction motors at				Auxiliary contacts	Rated control supply voltage U_s	DT	Spring-type terminals	PU (UNIT, SET, M)	PS*	PG
Operational current I_e at	230 V	400 V	500 V	690 V	Version			Order No.	Price € per PU		
400 V					NO	NC	V DC				
A	kW	kW	kW	kW							

For screw and snap-on mounting onto TH 35 standard mounting rail

Size S00

- Ident. No. 10, 1 NO

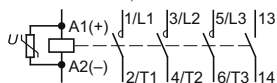

- Ident. No. 01, 1 NC

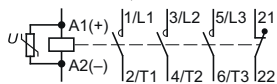

12	3	5,5	5,5	5,5	1 ¹⁾	--	24	▶	3RT10 17-2KB41	1	1 unit	41B
							110	B	3RT10 17-2KF41	1	1 unit	41B
12	3	5,5	5,5	5,5	--	1 ¹⁾	24	▶	3RT10 17-2KB42	1	1 unit	41B
							110	B	3RT10 17-2KF42	1	1 unit	41B

Size S0

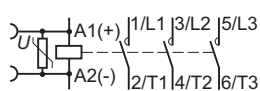

17	4	7,5	10	11	--	-- ²⁾	24	▶	3RT10 25-3KB40	1	1 unit	41B
							110	B	3RT10 25-3KF40	1	1 unit	41B
25	5,5	11	11	11	--	-- ²⁾	24	▶	3RT10 26-3KB40	1	1 unit	41B
							110	B	3RT10 26-3KF40	1	1 unit	41B

¹⁾ The auxiliary contacts are not expandable.

²⁾ Up to two single-pole auxiliary switch blocks can be mounted.

Accessories and spare parts see "3RT10 Contactors", Chapter 3.

Contactors for Special Applications

Contactors with extended operating range 0.7 ... 1.25 x U_s for railway applications

SIRIUS 3RT10 motor contactors, 5.5 ... 45 kW

DC operation - DC solenoid system
Solenoid coil with series resistor, fitted with varistor



3RT10 3.-3K.44-0LA0



3RT10 3.-3K.44-0LA0

Rated data AC-2 and AC-3 T_U : 70 °C	Auxiliary contacts	Rated control supply voltage U_s	DT	Spring-type terminals	PU (UNIT, SET, M)	PS*	PG
Operational current I_e at 400 V	Version			Order No.	Price € per PU		
Ratings of induction motors at	NO NC	V DC					
230 V							
400 V							
500 V							
690 V							
kW							

For screw and snap-on mounting onto TH 35 standard mounting rail

Size S00

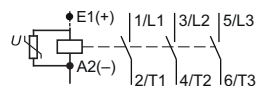

12	3	5,5	5,5	5,5	--	-- ¹⁾	24 110	A	3RT10 17-2KB42-0LA0	1	1 unit	41B
								B	3RT10 17-2KF42-0LA0	1	1 unit	41B

Size S0

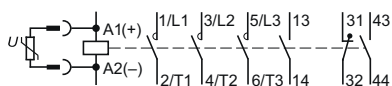

17	4	7,5	10	11	2	²⁾	24 110	B	3RT10 25-3KB44-0LA0	1	1 unit	41B
								B	3RT10 25-3KF44-0LA0	1	1 unit	41B
25	5,5	11	11	11	2	²⁾	24 110	B	3RT10 26-3KB44-0LA0	1	1 unit	41B
								B	3RT10 26-3KF44-0LA0	1	1 unit	41B

Size S2

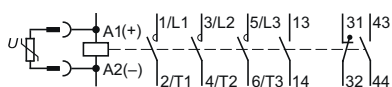

32	7,5	15	18,5	18,5	2	²⁾	24 110	B	3RT10 34-3KB44-0LA0	1	1 unit	41B
								B	3RT10 34-3KF44-0LA0	1	1 unit	41B
40	11	18,5	22	22	2	²⁾	24 110	B	3RT10 35-3KB44-0LA0	1	1 unit	41B
								B	3RT10 35-3KF44-0LA0	1	1 unit	41B
50	15	22	30	22	2	²⁾	24 110	B	3RT10 36-3KB44-0LA0	1	1 unit	41B
								B	3RT10 36-3KF44-0LA0	1	1 unit	41B

For screw and snap-on mounting onto TH 35 and TH 75 standard mounting rail

Size S3

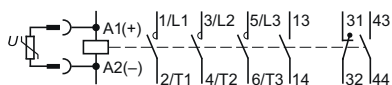

65	18,5	30	37	43	2	²⁾	24 110	B	3RT10 44-3KB44-0LA0	1	1 unit	41B
								B	3RT10 44-3KF44-0LA0	1	1 unit	41B
80	22	37	45	55	2	²⁾	24 110	B	3RT10 45-3KB44-0LA0	1	1 unit	41B
								B	3RT10 45-3KF44-0LA0	1	1 unit	41B
95	22	45	55	55	2	²⁾	24 110	B	3RT10 46-3KB44-0LA0	1	1 unit	41B
								B	3RT10 46-3KF44-0LA0	1	1 unit	41B

Accessories and spare parts see "3RT10 Contactors", Chapter 3.

- The integrated NC contact is used for switching the series resistor. A 4-pole auxiliary switch block according to EN 50005 can be mounted.
- The NC contact 21-22 is used for switching the series resistor. The auxiliary contacts are not expandable.



Contactors for Special Applications

Contactors with extended operating range $0.7 \dots 1.25 \times U_s$ for railway applications

**SIRIUS 3RT10 motor contactors,
5.5 ... 45 kW**

DC operation · DC solenoid system
Solid-state control unit
Solenoid coil fitted with varistor

PU (UNIT, SET, M) = 1
PS* = 1 unit
PG = 41B



3RT10 3.-3X.40-0LA2

Rated data AC-2 and AC-3 T_U : Up to 70 °C		Auxiliary contacts ¹⁾	Rated control supply voltage U_s	DT	Screw terminals	DT	Spring-type terminals for coil terminals	
Rated operational current I_e up to 400 V	Ratings of induction motors at 50 Hz and 400 V	Version			Order No.	Price € per PU	Order No.	Price € per PU
A	kW	NO NC	V DC					

For screw and snap-on mounting onto TH 35 standard mounting rail

Size S0

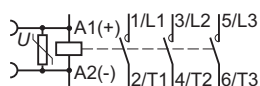

17	7,5	--	--	24	C	3RT10 25-1XB40-0LA2	B	3RT10 25-3XB40-0LA2
		--	--	110	B	3RT10 25-1XF40-0LA2	B	3RT10 25-3XF40-0LA2
25	11	--	--	24	B	3RT10 26-1XB40-0LA2	B	3RT10 26-3XB40-0LA2
		--	--	110	B	3RT10 26-1XF40-0LA2	B	3RT10 26-3XF40-0LA2

Size S2

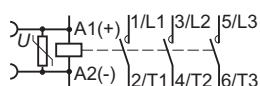

32	15	--	--	24	B	3RT10 34-1XB40-0LA2	C	3RT10 34-3XB40-0LA2
		--	--	110	B	3RT10 34-1XF40-0LA2	B	3RT10 34-3XF40-0LA2
40	18,5	--	--	24	B	3RT10 35-1XB40-0LA2	C	3RT10 35-3XB40-0LA2
		--	--	110	B	3RT10 35-1XF40-0LA2	B	3RT10 35-3XF40-0LA2
50	22	--	--	24	B	3RT10 36-1XB40-0LA2	B	3RT10 36-3XB40-0LA2
		--	--	110	B	3RT10 36-1XF40-0LA2	B	3RT10 36-3XF40-0LA2

For screw and snap-on mounting onto TH 35 and TH 75 standard mounting rail

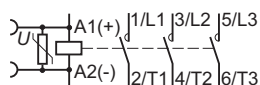

Size S3

65	30	--	--	24	B	3RT10 44-1XB40-0LA2	B	3RT10 44-3XB40-0LA2
		--	--	110	B	3RT10 44-1XF40-0LA2	B	3RT10 44-3XF40-0LA2
80	37	--	--	24	B	3RT10 45-1XB40-0LA2	B	3RT10 45-3XB40-0LA2
		--	--	110	B	3RT10 45-1XF40-0LA2	B	3RT10 45-3XF40-0LA2
95	45	--	--	24	B	3RT10 46-1XB40-0LA2	B	3RT10 46-3XB40-0LA2
		--	--	110	B	3RT10 46-1XF40-0LA2	B	3RT10 46-3XF40-0LA2

¹⁾ Auxiliary switch blocks mountable as 3RT10 standard contactors.

Controls – Contactors and Contactor Assemblies– Contactor Relays and Relays

5



Price Groups

PG 41A, 41B, 41H

5/2

Introduction

Contactor Relays

5/3

SIRIUS 3RH1 contactor relays,
4- and 8-pole

5/10

SIRIUS 3RH14 latched contactor relays,
4-pole

Coupling Relays

5/11

SIRIUS 3RH11 coupling relays
for switching auxiliary circuits,
4-pole

Contactors with Extended Operating Range $0.7 \dots 1.25 \times U_s$ for Railway Applications

5/13

SIRIUS 3RH11 contactor relays

More information can be found on the
Internet: [see the opening information,](#)
[page 8](#)

Introduction

Overview

The advantages at a glance



S00
3RH11



S00
3RH12

Size
Type

	Order No.	Page
3RH1 contactor relays		
4-pole	3RH11	5/5, 5/6
8-pole	3RH12	5/5, 5/6
4-pole, latched	3RH14	5/10
Coupling relays	3RH11	5/11
Contactor relays for railway applications	3RH11	5/13
Accessories for 3RH1 contactor relays		
Auxiliary switch blocks	3RH19 11	5/7
	3RH19 11	Chapter 3
Timing relay blocks	3RT19 16	Chapter 3
OFF-delay devices	3RT19 16	5/9
Surge suppressors	3RT19 16	5/8
Additional load modules	3RT19 16	5/8

Connection methods

The contactor relays are available with screw terminals (box terminals) or with spring-type terminals.



Screw terminals



Spring-type terminals

The terminals are indicated in the corresponding tables by the symbols shown on orange backgrounds.

Overview

Contactor relays and coupling relays, size S00, with accessories

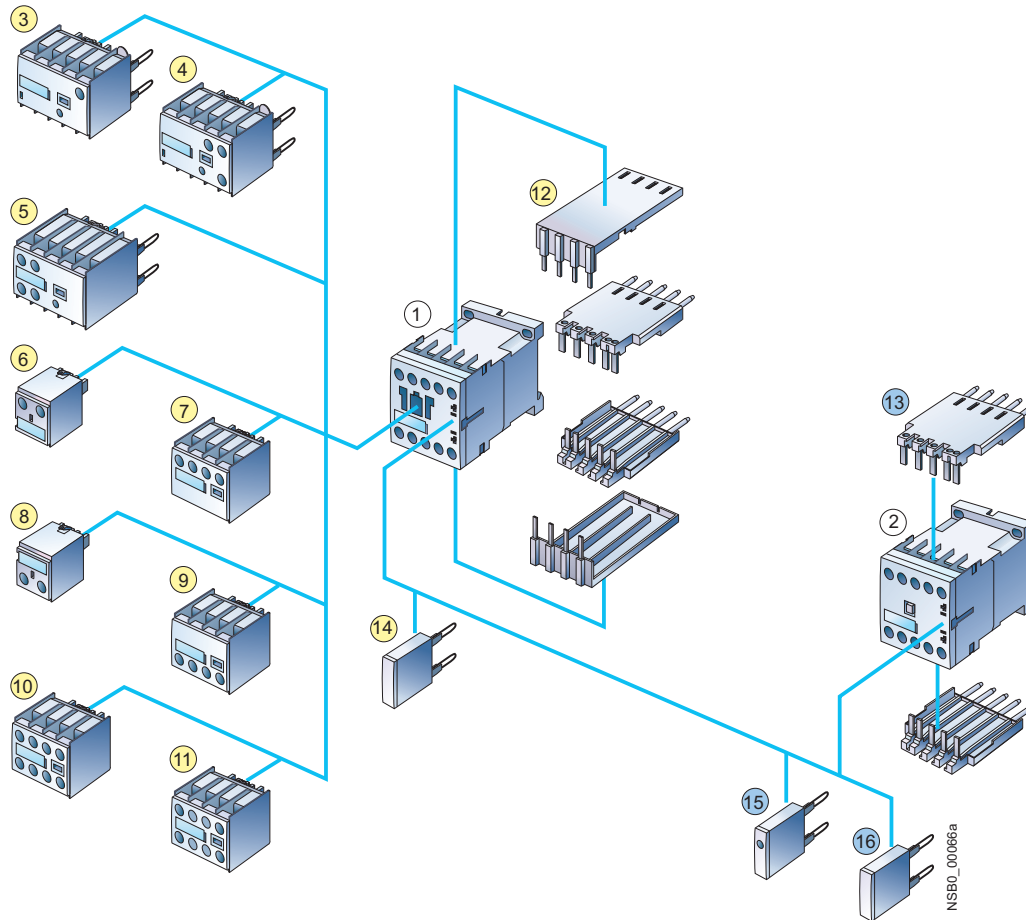

- ① Contactor relay
- ② Coupling relay for auxiliary circuits
- ③ Solid-state timing relay block, with ON-delay
- ④ Solid-state timing relay block, with OFF-delay
- ⑤ Auxiliary switch block, with solid-state time-delay (versions: ON or OFF-delay)
- ⑥ 1-pole auxiliary switch block, cable entry from above
- ⑦ 2-pole auxiliary switch block, cable entry from above
- ⑧ 1-pole auxiliary switch block, cable entry from below
- ⑨ 2-pole auxiliary switch block, cable entry from below
- ⑩ 4-pole auxiliary switch blocks (terminal designations according to EN 50011 or EN 50005)
- ⑪ 2-pole auxiliary switch block, standard version or solid-state compatible version (terminal designations according to EN 50005)
- ⑫ Solder pin adapter for contactor relays with 4-pole auxiliary switch block
- ⑬ Solder pin adapters for contactor relays and coupling relays
- ⑭ Additional load modules for increasing the permissible residual current
- ⑮ Surge suppressors with LED
- ⑯ Surge suppressors without LED

Contactors Relays

SIRIUS 3RH1 contactor relays, 4- and 8-pole

Standards

IEC 60947-1, EN 60947-1,
IEC 60947-5-1, EN 60947-5-1.

The 3RH1 contactor relays are suitable for use in any climate. They are finger-safe according to EN 50274.

The 3RH1 contactor relays have screw terminals or spring-type terminals. Four contacts are available in the basic unit. For expansions see "Accessories" on page 5/7.

Contact reliability

High contact stability at low voltages and currents, suitable for solid-state circuits with currents ≥ 1 mA at a voltage of ≥ 17 V.

Surge suppression

RC elements, varistors, diodes or diode assemblies (combination of a diode and a Zener diode) can be plugged onto all contactor relays from the front for damping opening surges in the coil. The plug-in direction is determined by a coding device.

Note:

The OFF-delay of the NO contact and the ON-delay of the NC contact are increased if the contactor coils are attenuated against voltage peaks (noise suppression diode 6 to 10 times; diode assembly 2 to 6 times, varistor +2 to 5 ms).

Auxiliary switch blocks

The 3RH1 contactor relays can be expanded by up to four contacts by the addition of snap-on auxiliary switch blocks.

The auxiliary switch block can easily be snapped onto the front of the contactors. The auxiliary switch block has a centrally positioned release lever for disassembly.

The contactor relays with 4 contacts with Ident. No. 40E according to EN 50011 can be extended with 3RH19 11-1GA .. auxiliary switch blocks to obtain contactor relays with 8 contacts according to EN 50011. The Ident. Nos. 80E to 44E on the auxiliary switch blocks apply to the complete contactors. These auxiliary switch blocks cannot be combined with contactor relays with Ident. Nos. 31E and 22E; they are coded.

All contactor relays with 4 contacts with Ident. Nos. 40E to 22E can be extended with auxiliary switch blocks 40 to 02 to obtain contactor relays with 6 or 8 contacts in accordance with EN 50005. The Ident. Nos. on the auxiliary switch blocks apply only to the attached auxiliary switch blocks.

In addition, fully mounted 3RH12 8-pole contactor relays are available; the mounted 4-pole auxiliary switch block in the 2nd tier is not removable. The terminal designations are in accordance with EN 50011 or IEC 60947-5-1.

These versions are built according to special Swiss regulations SUVA and are distinguished externally by a red labeling plate.

Of the auxiliary contacts (integrated plus mountable) possible on the device, no more than 4 NC contacts are permitted.

Order No. scheme

Digit of the Order No.	1.	2.	3.	4.	5.	6.	7.	8.	9.	10.	11.	12.	13.	14.	15.	16.
	□	□	□	□	□	□	□	-	□	□	□	□	□	□	□	□
SIRIUS contactor relays	3 R H															
1. generation	1															
Device type (e. g. 1 = 4-pole contactor relay, 2 = 8-pole contactor relay)	□															
Number of NO contacts (e. g. 2 = 2 NO)	□															
Number of NC contacts (e. g. 2 = 2 NC)	□															
Connection type (1 = screw, 2 = spring)	□															
Operating range / solenoid coil circuit (e. g. A = AC standard / without)	□															
Rated control supply voltage (e. g. P0 = 230 V, 50 Hz)	□ □															
No significance (0)	□															
Special version	□ □ □ □															
Example	3	R	H	1	1	2	2	-	1	A	P	0	0			

Note:

The Order No. scheme is presented here merely for information purposes and for better understanding of the logic behind the order numbers.

For your orders, please use the order numbers quote in the catalog in the Selection and ordering data.

SIRIUS 3RH1 contactor relays, 4- and 8-pole

Selection and ordering data

AC operation

PU (UNIT, SET, M) = 1
 PS* = 1 unit
 PG = 41A

Size S00



Rated operational current $I_{th}/AC-15/AC-14$ at 230 V	Contacts Ident. No. Version	Rated control supply voltage U_s at 50/60 Hz ¹⁾	DT	Screw terminals	DT	Spring-type terminals
				Order No.	Price € per PU	Order No.
						Price € per PU

For screw and snap-on mounting onto TH 35 standard mounting rail

Terminal designations according to EN 50011

4 NO, Ident. No. 40E	3 NO + 1 NC, Ident. No. 31E	2 NO + 2 NC, Ident. No. 22E																																																															
<table border="1"> <tr> <td>6</td> <td>40E</td> <td>4</td> <td>--</td> <td>24</td> <td>▶ 3RH11 40-1AB00</td> <td>▶ 3RH11 40-2AB00</td> </tr> <tr> <td></td> <td></td> <td></td> <td></td> <td>110</td> <td>▶ 3RH11 40-1AF00</td> <td>▶ 3RH11 40-2AF00</td> </tr> <tr> <td></td> <td></td> <td></td> <td></td> <td>230</td> <td>▶ 3RH11 40-1AP00</td> <td>▶ 3RH11 40-2AP00</td> </tr> </table>	6	40E	4	--	24	▶ 3RH11 40-1AB00	▶ 3RH11 40-2AB00					110	▶ 3RH11 40-1AF00	▶ 3RH11 40-2AF00					230	▶ 3RH11 40-1AP00	▶ 3RH11 40-2AP00	<table border="1"> <tr> <td></td> <td>31E</td> <td>3</td> <td>1</td> <td>24</td> <td>▶ 3RH11 31-1AB00</td> <td>▶ 3RH11 31-2AB00</td> </tr> <tr> <td></td> <td></td> <td></td> <td></td> <td>110</td> <td>▶ 3RH11 31-1AF00</td> <td>▶ 3RH11 31-2AF00</td> </tr> <tr> <td></td> <td></td> <td></td> <td></td> <td>230</td> <td>▶ 3RH11 31-1AP00</td> <td>▶ 3RH11 31-2AP00</td> </tr> </table>		31E	3	1	24	▶ 3RH11 31-1AB00	▶ 3RH11 31-2AB00					110	▶ 3RH11 31-1AF00	▶ 3RH11 31-2AF00					230	▶ 3RH11 31-1AP00	▶ 3RH11 31-2AP00	<table border="1"> <tr> <td></td> <td>22E</td> <td>2</td> <td>2</td> <td>24</td> <td>▶ 3RH11 22-1AB00</td> <td>▶ 3RH11 22-2AB00</td> </tr> <tr> <td></td> <td></td> <td></td> <td></td> <td>110</td> <td>▶ 3RH11 22-1AF00</td> <td>▶ 3RH11 22-2AF00</td> </tr> <tr> <td></td> <td></td> <td></td> <td></td> <td>230</td> <td>▶ 3RH11 22-1AP00</td> <td>▶ 3RH11 22-2AP00</td> </tr> </table>		22E	2	2	24	▶ 3RH11 22-1AB00	▶ 3RH11 22-2AB00					110	▶ 3RH11 22-1AF00	▶ 3RH11 22-2AF00					230	▶ 3RH11 22-1AP00	▶ 3RH11 22-2AP00
6	40E	4	--	24	▶ 3RH11 40-1AB00	▶ 3RH11 40-2AB00																																																											
				110	▶ 3RH11 40-1AF00	▶ 3RH11 40-2AF00																																																											
				230	▶ 3RH11 40-1AP00	▶ 3RH11 40-2AP00																																																											
	31E	3	1	24	▶ 3RH11 31-1AB00	▶ 3RH11 31-2AB00																																																											
				110	▶ 3RH11 31-1AF00	▶ 3RH11 31-2AF00																																																											
				230	▶ 3RH11 31-1AP00	▶ 3RH11 31-2AP00																																																											
	22E	2	2	24	▶ 3RH11 22-1AB00	▶ 3RH11 22-2AB00																																																											
				110	▶ 3RH11 22-1AF00	▶ 3RH11 22-2AF00																																																											
				230	▶ 3RH11 22-1AP00	▶ 3RH11 22-2AP00																																																											

* With permanently mounted auxiliary switch block for safety applications according to SUVA

4 NO + 4 NC, Ident. No. 44E	6 NO + 2 NC, Ident. No. 62E																
<table border="1"> <tr> <td>6</td> <td>44E</td> <td>4</td> <td>4</td> <td>230</td> <td>▶ 3RH12 44-1AP00</td> <td>B</td> <td>3RH12 44-2AP00</td> </tr> <tr> <td></td> <td>62E</td> <td>6</td> <td>2</td> <td>230</td> <td>▶ 3RH12 62-1AP00</td> <td>B</td> <td>3RH12 62-2AP00</td> </tr> </table>	6	44E	4	4	230	▶ 3RH12 44-1AP00	B	3RH12 44-2AP00		62E	6	2	230	▶ 3RH12 62-1AP00	B	3RH12 62-2AP00	
6	44E	4	4	230	▶ 3RH12 44-1AP00	B	3RH12 44-2AP00										
	62E	6	2	230	▶ 3RH12 62-1AP00	B	3RH12 62-2AP00										

¹⁾ Coil operating range
 at 50 Hz: 0.8 to 1.1 x U_s
 at 60 Hz: 0.85 to 1.1 x U_s .

Other voltages according to page 5/7 on request.

Accessories see pages 5/7 to 5/9 and "Accessories for 3RT1 Contactors", Chapter 3.

Contactor Relays

SIRIUS 3RH1 contactor relays, 4- and 8-pole

DC operation - DC solenoid system

PU (UNIT, SET, M) = 1
 PS* = 1 unit
 PG = 41A

Size S00



3RH11 ...-1B.40



3RH11 ...-2B.40



3RH12 ...-1B.40

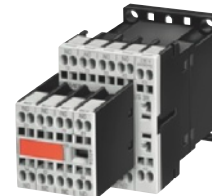

3RH12 ...-2B.40

Rated operational current I_e /AC-15/AC-14 at 230 V	Contacts		Rated control supply voltage U_s	DT	Screw terminals		DT	Spring-type terminals	
	Ident. No.	Version			Order No.	Price € per PU		Order No.	Price € per PU
A		NO NC V DC							

For screw and snap-on mounting onto TH 35 standard mounting rail

Terminal designations according to EN 50011

4 NO, Ident. No. **40E**

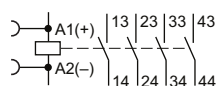

3 NO + 1 NC, Ident. No. **31E**

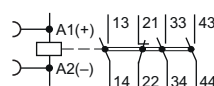

2 NO + 2 NC, Ident. No. **22E**

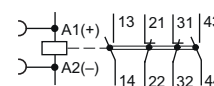

6	40E	4	--	24 220	▶	3RH11 40-1BB40 3RH11 40-1BM40	▶	3RH11 40-2BB40 3RH11 40-2BM40
	31E	3	1	24 220	▶	3RH11 31-1BB40 3RH11 31-1BM40	▶	3RH11 31-2BB40 3RH11 31-2BM40
	22E	2	2	24 220	▶	3RH11 22-1BB40 3RH11 22-1BM40	▶	3RH11 22-2BB40 3RH11 22-2BM40

• With permanently mounted auxiliary switch block for safety applications according to SUVA

4 NO + 4 NC, Ident. No. **44E**

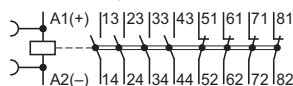

6 NO + 2 NC, Ident. No. **62E**

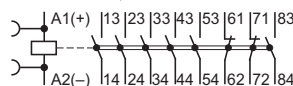

6	44E	4	4	24	▶	3RH12 44-1BB40	A	3RH12 44-2BB40
	62E	6	2	24	▶	3RH12 62-1BB40	A	3RH12 62-2BB40

Other voltages according to page 5/7 on request.

Accessories [see pages 5/7 to 5/9](#) and "Accessories for 3RT2 Contactors", Chapter 3.

SIRIUS 3RH1 contactor relays, 4- and 8-pole

Options

Rated control supply voltages
(the 10th and 11th position of the order number must be changed)

Contactor type		3RH11
Rated control supply voltage U_s	Control supply voltage at	
AC operation		
Solenoid coils for 50/60 Hz and 60 Hz		
50/60 Hz¹⁾	60 Hz	
24 V AC	--	B0
42 V AC	--	D0
48 V AC	--	H0
110 V AC	--	F0
220 V AC	--	N2
230 V AC	--	P0
400 V AC	--	V0
Solenoid coils for USA and Canada²⁾		
50 Hz	60 Hz	
110 V AC	120 V AC	K6
220 V AC	240 V AC	P6
Solenoid coils for Japan³⁾		
50/60 Hz	60 Hz	
100 V AC	110 V AC	G6
200 V AC	220 V AC	N6
400 V AC	440 V AC	R6

Contactor type		3RH11
Rated control supply voltage U_s	Control supply voltage at	
DC operation		
12 V DC		A4
24 V DC		B4
42 V DC		D4
48 V DC		W4
60 V DC		E4
110 V DC		F4
125 V DC		G4
220 V DC		M4
230 V DC		P4

- 1) Coil operating range at 50 Hz: 0.8 to 1.1 x U_s
at 60 Hz: 0.85 to 1.1 x U_s .
- 2) Coil operating range at 50 Hz: 0.85 to 1.1 x U_s
at 60 Hz: 0.8 to 1.1 x U_s .
- 3) Coil operating range at 50/60 Hz: 0.85 to 1.1 x U_s
at 60 Hz: 0.8 to 1.1 x U_s .

Accessories

PU (UNIT, SET, M) = 1
PS* = 1 unit
PG = 41B

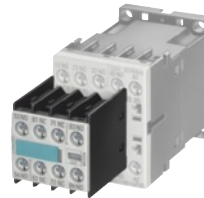

3RH19 11-1GA22

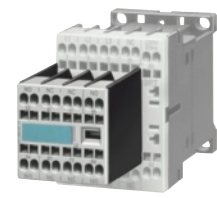

3RH19 11-2GA22

For contactor relays	Contactor relays with AS block	Auxiliary contacts	DT	Screw terminals	DT	Spring-type terminals	
	Ident. No.	Version		⊕		⊕	
Type		 NO NC		Order No.	Price € per PU	Order No.	Price € per PU

Auxiliary switch blocks for snapping onto the front acc. to EN 50011

Size S00¹⁾

For assembling contactor relays with 8 contacts

3RH11 40, 3RH14 40, Ident. No. 40E	80E	4	--	
	71E	3	1	
	62E	2	2	
	53E	1	3	
	44E	--	4 ²⁾	

▶ 3RH19 11-1GA40	▶ 3RH19 11-2GA40
▶ 3RH19 11-1GA31	▶ 3RH19 11-2GA31
▶ 3RH19 11-1GA22	▶ 3RH19 11-2GA22
▶ 3RH19 11-1GA13	▶ 3RH19 11-2GA13
▶ 3RH19 11-1GA04	▶ 3RH19 11-2GA04

Auxiliary switch blocks and solid-state compatible auxiliary switch blocks according to EN 50005 see "Accessories for 3RT1 Contactors", Chapter 3.

Contactors Relays

SIRIUS 3RH1 contactor relays, 4- and 8-pole

For contactors	Version	Rated control supply voltage $U_s^{1)}$		Power consumption of LED at U_s	DT	Order No. ²⁾	Price € per PU	PU (UNIT, SET, M)	PS*	PG
		AC operation	DC operation							
Type		V AC	V DC	mW						

Surge suppressors with LED

Size S00 (also for spring-type terminals)

For plugging onto the front side of the contactors with and without auxiliary switch blocks



3RT19 16-1L.00

3RT1, 3RH1	Varistor	24 ... 48	12 ... 24	10 ... 120	▶	3RT19 16-1JJ00	1	1 unit	41B
		48 ... 127	24 ... 70	20 ... 470	▶	3RT19 16-1JK00	1	1 unit	41B
		127 ... 240	70 ... 150	50 ... 700	▶	3RT19 16-1JL00	1	1 unit	41B
		--	150 ... 250	160 ... 950	▶	3RT19 16-1JP00	1	1 unit	41B
3RT1, 3RH1	Noise suppression diodes	--	24 ... 70	20 ... 470	▶	3RT19 16-1LM00	1	1 unit	41B
		--	50 ... 150	50 ... 700	▶	3RT19 16-1LN00	1	1 unit	41B
		--	150 ... 250	160 ... 950	▶	3RT19 16-1LP00	1	1 unit	41B

1) Can be used for AC operation for 50/60 Hz. Please inquire about further voltages.

2) For packs of 10 or 5 units "-Z" and order code "X90" must be added to the Order No.

For contactors	Version	Rated control supply voltage $U_s^{1)}$		DT	Order No. ²⁾	Price € per PU	PU (UNIT, SET, M)	PS*	PG
		AC operation	DC operation						
Type		V AC	V DC						

Surge suppressors without LED

Size S00 (also for spring-type terminals)

For plugging onto the front side of the contactors with and without auxiliary switch blocks



3RT19 16-1DG00

3RT1., 3RH1	Varistor	24 ... 48	24 ... 70	▶	3RT19 16-1BB00	1	1 unit	41B
		48 ... 127	70 ... 150	▶	3RT19 16-1BC00	1	1 unit	41B
		127 ... 240	150 ... 250	A	3RT19 16-1BD00	1	1 unit	41B
		240 ... 400	--	▶	3RT19 16-1BE00	1	1 unit	41B
		400 ... 600	--	A	3RT19 16-1BF00	1	1 unit	41B
3RT1., 3RH1	RC elements	24 ... 48	24 ... 70	▶	3RT19 16-1CB00	1	1 unit	41B
		48 ... 127	70 ... 150	▶	3RT19 16-1CC00	1	1 unit	41B
		127 ... 240	150 ... 250	▶	3RT19 16-1CD00	1	1 unit	41B
		240 ... 400	--	▶	3RT19 16-1CE00	1	1 unit	41B
		400 ... 600	--	▶	3RT19 16-1CF00	1	1 unit	41B
3RT1., 3RH1	Noise suppression diodes	--	12 ... 250	▶	3RT19 16-1DG00	1	1 unit	41B
3RT1., 3RH1	Diode assemblies (diode and Zener diode) for DC operation	--	12 ... 250	▶	3RT19 16-1EH00	1	1 unit	41B

1) Can be used for AC operation for 50/60 Hz. Please inquire about further voltages.

2) For packs of 10 or 5 units "-Z" and order code "X90" must be added to the Order No.

For contactors	Version	DT	Order No. ¹⁾	Price € per PU	PU (UNIT, SET, M)	PS*	PG
Type							

Additional load modules

Size S00 (also for spring-type terminals)

For plugging onto the front side of the contactors with and without auxiliary switch blocks



3RT19 16-1GA00

3RT1., 3RH1.	For increasing the permissible residual current and for limiting the residual voltage. Ensures safe opening of contactors with direct control via 230 V AC semiconductor outputs of SIMATIC controllers. Also performs the function of an overvoltage damping circuit. Rated voltage: AC 50/60 Hz, 180 V to 255 V. Operating range: 0.8 to 1.1 x U_s	▶	3RT19 16-1GA00	1	1 unit	41B
--------------	--	---	-----------------------	---	--------	-----

1) For packs of 10 units, the Order No. must be supplemented with "-Z" and the order code "X90".

SIRIUS 3RH1 contactor relays, 4- and 8-pole

For contactors	Rated control supply voltage U_s	Time setting range t	DT	Screw terminals	⊕	PU (UNIT, SET, M)	PS*	PG
Type	V	s		Order No.		Price € per PU		

OFF-delay devices

Size S00

For contactor relays with DC operation

Non-adjustable delay time

3RH1...-1BF40	110 AC/DC	S00: 130 non-adjustable	D	3RT19 16-2BK01		1	1 unit	41H
3RH1...-1BM40	220/230 AC/DC	S00: 600 non-adjustable	D	3RT19 16-2BL01		1	1 unit	41H
3RH1...-1BB40	24 DC	S00: 250 non-adjustable	▶	3RT19 16-2BE01		1	1 unit	41H



3RT19 16-2B.01

For contactors	Version	DT	Order No.	Price € per PU	PU (UNIT, SET, M)	PS*	PG
Type							

Control kit

Size S00

3RH1.	For manual operation of the contactor contacts for start-up and service	A	3RK1 903-0CA00		1	1 unit	42D
-------	---	---	-----------------------	--	---	--------	-----



3RK1 903-0CA00

Sealable covers

Size S00

3RH1 ¹⁾	Sealable covers for preventing manual operation	C	3RT19 16-4MA10		1	5 units	41B
--------------------	---	---	-----------------------	--	---	---------	-----

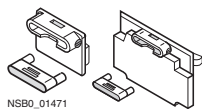

NSB0_01471

3RT19 .6-4MA10

¹⁾ Not for contactor relays with auxiliary switch block mounted onto the front.

Version	DT	Spring-type terminals	∞	PU (UNIT, SET, M)	PS*	PG
		Order No.		Price € per PU		

Insulation stop for securely holding back the conductor insulation on conductors up to 1 mm²



3RT19 16-4JA02

Insulation stop strip can be inserted in cable entry of the spring-type terminal (2 strips per contactor required)

- For auxiliary and control current on basic devices and for mountable 3RH19 auxiliary switches, removable in pairs

B	3RT19 16-4JA02		1	20 units	41B
---	-----------------------	--	---	----------	-----

Tools for opening spring-type terminals

Screwdrivers

for all SIRIUS devices with spring-type terminals

Length: approx. 200 mm,
3.0 mm x 0.5 mm,
titanium gray/black, partially insulated



3RA29 08-1A

A	3RA29 08-1A		1	1 unit	41B
---	--------------------	--	---	--------	-----

More accessories see "Accessories for 3RT1 Contactors", Chapter 3.

Contactors Relays

SIRIUS 3RH14 latched contactor relays, 4-pole

Overview

Standards

IEC 60947-1, EN 60947-1,
IEC 60947-5-1, EN 60947-5-1

The terminal designations comply with EN 50011.

Auxiliary switches

The number of auxiliary contacts can be extended by means of front auxiliary switch blocks (max. 4 contacts).

Control circuit

The contactor coil and the coil of the release solenoid are both designed for uninterrupted duty.

RC elements, varistors diodes or diode assemblies can be fitted to both coils from the front for damping opening surges in the coil.

The contactor relay can also be switched on and released manually. Minimum actuating times [see internet addresses for more information, page 8.](#)



3RH14 22-1A..0

Selection and ordering data

Rated operational current I_e /AC-15/AC-14 at 230 V	Contacts Ident. No. acc. to EN 50011	Version	Rated control supply voltage U_s	DT	Screw terminals	⊕	PU (UNIT, SET, M)	PS*	PG
					Order No.	Price € per PU			

A NO NC V

For screw and snap-on mounting onto TH 35 standard mounting rail

Terminal designations according to EN 50011

4 NO, Ident. No. **40E**

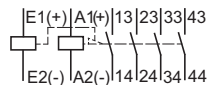

3 NO + 1 NC, Ident. No. **31E**

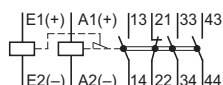

2 NO + 2 NC, Ident. No. **22E**

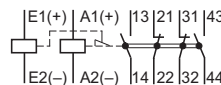

AC operation

6	40E	4	--	AC 50/60 Hz ¹⁾		DT	Order No.	PU	PS*	PG
				24	42					
				24	42	B	3RH14 40-1AB00	1	1 unit	41A
				110	230	B	3RH14 40-1AD00	1	1 unit	41A
				110	230	B	3RH14 40-1AF00	1	1 unit	41A
				230	230	A	3RH14 40-1AP00	1	1 unit	41A
	31E	3	1	24	42	B	3RH14 31-1AB00	1	1 unit	41A
				110	230	B	3RH14 31-1AD00	1	1 unit	41A
				110	230	B	3RH14 31-1AF00	1	1 unit	41A
				230	230	B	3RH14 31-1AP00	1	1 unit	41A
	22E	2	2	24	42	B	3RH14 22-1AB00	1	1 unit	41A
				110	230	B	3RH14 22-1AD00	1	1 unit	41A
				110	230	B	3RH14 22-1AF00	1	1 unit	41A
				230	230	▶	3RH14 22-1AP00	1	1 unit	41A

DC operation · DC solenoid system

6	40E	4	--	DC		DT	Order No.	PU	PS*	PG
				24	110					
				24	110	▶	3RH14 40-1BB40	1	1 unit	41A
				220	220	B	3RH14 40-1BF40	1	1 unit	41A
				220	220	B	3RH14 40-1BM40	1	1 unit	41A
	31E	3	1	24	110	B	3RH14 31-1BB40	1	1 unit	41A
				110	220	B	3RH14 31-1BF40	1	1 unit	41A
				220	220	B	3RH14 31-1BM40	1	1 unit	41A
	22E	2	2	24	110	▶	3RH14 22-1BB40	1	1 unit	41A
				110	220	B	3RH14 22-1BF40	1	1 unit	41A
				220	220	B	3RH14 22-1BM40	1	1 unit	41A

¹⁾ Coil operating range
at 50 Hz: 0.8 to 1.1 × U_s
at 60 Hz: 0.85 to 1.1 × U_s .

Accessories [see pages 5/7 and 5/8.](#)

Contactor Relays

Coupling relays

SIRIUS 3RH11 coupling relays for switching auxiliary circuits, 4-pole

Overview

DC operation

IEC 60947-1, EN 60947-1,
IEC 60947-5-1, EN 60947-5-1

The 3RH11 coupling relays for switching auxiliary circuits are tailored to the special requirements of working with electronic controls.

The 3RH11 coupling relays cannot be extended with auxiliary switch blocks.

Coupling relays have a low power consumption and an extended coil operating range.

Depending on the version, the solenoid coils are supplied either without overvoltage damping (3RH11 ...-HB40 or 3RH11 ...-MB40-0KT0 versions) or with a diode or varistor connected as standard.

Selection and ordering data

DC operation

Low power consumption

Extended operating range of the solenoid coil

Solenoid coil with surge suppression

PU (UNIT, SET, M) = 1
PS* = 1 unit
PG = 41A



3RH11 ...-1.B40



3RH11 ...-2.B40

Rated operational current $I_{th}/AC-15/AC-14$ at 230 V	Auxiliary contacts Ident. No. acc. to EN 50011	Version	DT	Screw terminals	DT	Spring-type terminals	
				Order No.	Price € per PU	Order No.	Price € per PU
		 NO NC					

A

For screw and snap-on mounting onto TH 35 standard mounting rail

Size S00

Diode, varistor or RC element, attachable

Terminal designations according to EN 50011 (no auxiliary switch blocks can be mounted)

4 NO, Ident. No. **40E**

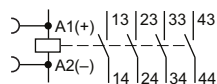

3 NO + 1 NC, Ident. No. **31E**

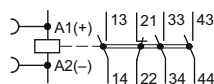

2 NO + 2 NC, Ident. No. **22E**

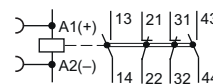

Rated control supply voltage $U_s = 24 V$ DC, coil operating range **0.7 to 1.25 x U_s**
Power consumption of the coils **2.3 W** at 24 V

6	40E	4	--	▶	3RH11 40-1HB40	B	3RH11 40-2HB40
	31E	3	1	▶	3RH11 31-1HB40	B	3RH11 31-2HB40
	22E	2	2	▶	3RH11 22-1HB40	B	3RH11 22-2HB40

Rated control supply voltage $U_s = 24 V$ DC, coil operating range **0.85 to 1.85 x U_s**
Power consumption of the coils **1.4 W** at 24 V

6	40E	4	--	B	3RH11 40-1MB40-0KT0	B	3RH11 40-2MB40-0KT0
	31E	3	1	B	3RH11 31-1MB40-0KT0	B	3RH11 31-2MB40-0KT0
	22E	2	2	A	3RH11 22-1MB40-0KT0	B	3RH11 22-2MB40-0KT0

Surge suppressors [see page 5/8](#).

Contactor Relays

Coupling relays

SIRIUS 3RH11 coupling relays for switching auxiliary circuits, 4-pole

PU (UNIT, SET, M) = 1
 PS* = 1 unit
 PG = 41A



3RH11...-1.B40



3RH11...-2.B40

Rated operational current $I_{th}/AC-15/AC-14$ at 230 V	Auxiliary contacts		DT	Screw terminals		DT	Spring-type terminals	
	Ident. No. acc. to EN 50011	Version		Order No.	Price € per PU		Order No.	Price € per PU

A
 For screw and snap-on mounting onto TH 35 standard mounting rail

Size S00

With integrated coil circuit (diode)

Terminal designations according to EN 50011 (no auxiliary switch blocks can be mounted)

4 NO, Ident. No. **40E**

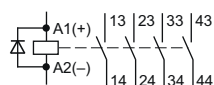

3 NO + 1 NC, Ident. No. **31E**

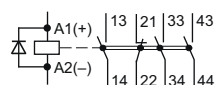

2 NO + 2 NC, Ident. No. **22E**

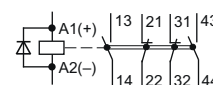

Rated control supply voltage $U_s = 24$ V DC, coil operating range **0.7 to 1.25 x U_s**
 Power consumption of the coils **2.3 W** at 24 V

6	40E	4	--	▶	3RH11 40-1JB40	B	3RH11 40-2JB40
	31E	3	1	▶	3RH11 31-1JB40	▶	3RH11 31-2JB40
	22E	2	2	▶	3RH11 22-1JB40	B	3RH11 22-2JB40

Rated control supply voltage $U_s = 24$ V DC, coil operating range **0.85 to 1.85 x U_s**
 Power consumption of the coils **1.4 W** at 24 V

6	40E	4	--	B	3RH11 40-1VB40	B	3RH11 40-2VB40
	31E	3	1	A	3RH11 31-1VB40	B	3RH11 31-2VB40
	22E	2	2	B	3RH11 22-1VB40	B	3RH11 22-2VB40

With integrated coil circuit (varistor)

Terminal designations according to EN 50011 (no auxiliary switch blocks can be mounted)

4 NO, Ident. No. **40E**

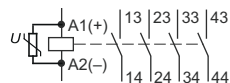

3 NO + 1 NC, Ident. No. **31E**

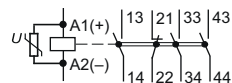

2 NO + 2 NC, Ident. No. **22E**

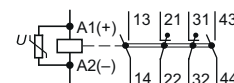

Rated control supply voltage $U_s = 24$ V DC, coil operating range **0.7 to 1.25 x U_s**
 Power consumption of the coils **2.3 W** at 24 V

6	40E	4	--	▶	3RH11 40-1KB40	B	3RH11 40-2KB40
	31E	3	1	▶	3RH11 31-1KB40	▶	3RH11 31-2KB40
	22E	2	2	▶	3RH11 22-1KB40	▶	3RH11 22-2KB40

Rated control supply voltage $U_s = 24$ V DC, coil operating range **0.85 to 1.85 x U_s**
 Power consumption of the coils **1.4 W** at 24 V

6	40E	4	--	B	3RH11 40-1WB40	B	3RH11 40-2WB40
	31E	3	1	A	3RH11 31-1WB40	B	3RH11 31-2WB40
	22E	2	2	A	3RH11 22-1WB40	B	3RH11 22-2WB40

Contactors with extended operating range $0.7 \dots 1.25 \times U_s$ for railway applications

SIRIUS 3RH11 contactor relays

Overview

DC operation

IEC 60947-4-1, EN 60947-4-1, for requirements acc. to IEC 60077-1 and IEC 60077-2

The contactor relays are finger-safe according to EN 50274. The size S00 contactor relays have spring-type connections for all terminals.

Ambient temperature

The permissible ambient temperature for operation of the contactor relays (across the full coil operating range) is -40 to $+70$ °C.

Uninterrupted duty at temperatures $> +60$ °C reduces the mechanical endurance, the load rating capacity of the conducting paths and the switching frequency.

Control and auxiliary circuits

The solenoid coils of the contactor relays have an extended coil operating range from 0.7 to $1.25 \times U_s$ and are fitted as standard with surge suppressors. The opening delay is therefore 2 to 5 ms longer than for standard contactors.

Application

For operation in installations which are subject both to considerable variations in the control voltage and to high ambient temperatures, e. g. railway applications under extreme climatic conditions, rolling mills, etc.

Also for control supply voltages with battery buffering to extend the operating time in the event of battery charge failure.

Contactor relays with conventional coil

Control and auxiliary circuits

These auxiliary contactor relays have an extended operating range from 0.7 to $1.25 \times U_s$; the coils are fitted with varistors as standard. An additional series resistor is not required.

Note:

An additional auxiliary switch block cannot be mounted.

Mounting

A clearance of 10 mm is required for side-by-side mounting at ambient temperatures > 60 °C ≤ 70 °C.

Contactor relays with series resistor

Control and auxiliary circuits

The DC solenoid systems of the contactor relays are modified (to holding excitation) by means of a series resistor.

The contactor relays are supplied prewired with a plug-on module containing the series resistor. A surge suppressor (varistor) is integrated.

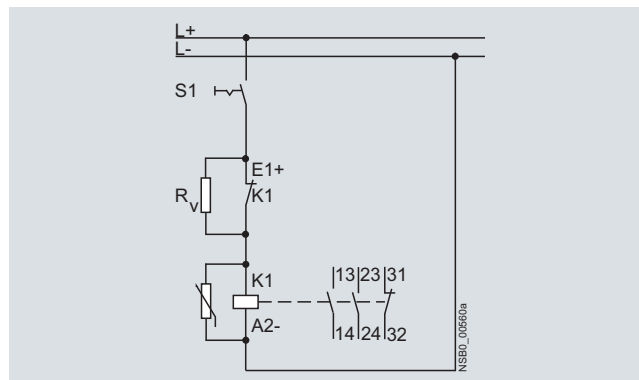

Circuit diagram

A 4-pole auxiliary switch block (according to EN 50005) can be fitted additionally.

Side-by-side mounting

Side-by-side-side mounting is permissible at ambient temperatures up to 70 °C.

Contactor Relays

Contactors with extended operating range $0.7 \dots 1.25 \times U_s$ for railway applications

SIRIUS 3RH11 contactor relays

Selection and ordering data

DC operation · DC solenoid system
Spring-type terminals
For screw and snap-on mounting onto standard mounting rails
Solenoid coil with integrated surge suppression



3RH11 22-2K.40



3RH11 22-2K.40-0LA0

Rated operational current				Contacts		Rated control supply voltage U_s	DT	Spring-type terminals	PU (UNIT, SET, M)	PS*	PG
$I_e/AC-15/AC-14$ $T_U: 70^\circ C$ at				Version							
230 V	400 V	500 V	690 V	NO	NC	V DC					
A	A	A	A				Order No.	Price € per PU			

For screw and snap-on mounting onto TH 35 standard mounting rail

Size S00

With conventional coil, fitted with varistor

Terminal designations acc. to EN 50011

2 NO + 2 NC, Ident. No. **22E**

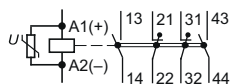

6	3	2	1	2	2 ¹⁾	24	▶ 3RH11 22-2KB40		1	1 unit	41A
						110			3RH11 22-2KF40	1	1 unit

With series resistor, fitted with varistor

Terminal designations acc. to EN 50011

2 NO + 1 NC, Ident. No. **21X**

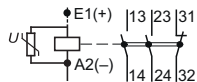

6	3	2	1	2	1 ²⁾	24	▶ 3RH11 22-2KB40-0LA0		1	1 unit	41A
						110			3RH11 22-2KF40-0LA0	1	1 unit

1) It is not possible to mount an auxiliary switch block.
 2) 4-pole auxiliary switch block acc. to EN 50005 can be mounted.

Protection Equipment



Price Groups

PG 41B, 41E, 41F, 41G, 41H, 41J, 143

7/2

Introduction

SIRIUS 3RV1 Motor Starter Protectors up to 100 A

7/5 General data

7/8 For motor protection

7/11 For motor protection
with overload relay function

7/12 For starter combinations

7/13 For transformer protection

7/14 For fuse monitoring

7/15 For system protection acc. to
UL 489/CSA C22.2 No. 5-02

7/16 For transformer protection acc. to
UL 489/CSA C22.2 No.5-02

7/17 For distance protection

Accessories

7/18 - Mountable accessories

7/21 - Busbar accessories

7/24 - Rotary operating mechanisms

7/26 - Mounting accessories

7/30 - Enclosures and front plates

7/33 3RV19 infeed systems

Overload Relays

7/37 General data

SIRIUS 3RU1 Thermal Overload Relays

7/41 3RU11 up to 100 A
for standard applications

7/46 Accessories

SIRIUS 3RB2 Solid-State Overload Relays

7/48 3RB20, 3RB21 up to 630 A
for standard applications

7/53 Accessories for 3RB20, 3RB21

7/55 3RB22, 3RB23 up to 630 A
for High-Feature applications

7/60 Current measuring modules
for 3RB22, 3RB23

7/61 Accessories for 3RB22, 3RB23

More information can be found
on the Internet: [see the opening information, page 8](#)

Introduction

Overview



Type	3RV10	3RV11	3RV13	3RV14	3RV16	3RV16	3RV17	3RV18
SIRIUS 3RV1 motor starter protectors up to 100 A								
Applications								
System protection	✓ ¹⁾	✓ ¹⁾	--	--	--	--	✓	✓
Motor protection	✓	--	--	--	--	--	--	--
Motor protection with overload relay function	--	✓	--	--	--	--	--	--
Starter combinations	--	--	✓	--	--	--	--	--
Transformer protection	--	--	--	✓	--	--	✓	✓
Fuse monitoring	--	--	--	--	✓	--	--	--
Voltage transformer circuit breaker for distance protection	--	--	--	--	--	✓	--	--
Size	S00, S0, S2, S3	S0, S2, S3	S0, S2, S3	S0, S2	S00	S00	S0, S3	S0
Rated current I_n								
• Size S00	A Up to 12	--	--	--	0,2	Up to 3	--	--
• Size S0	A Up to 25	Up to 25	Up to 25	Up to 20	--	--	Up to 22	Up to 20
• Size S2	A Up to 50	Up to 50	Up to 50	Up to 40	--	--	--	--
• Size S3	A Up to 100	Up to 100	Up to 100	--	--	--	Up to 70	--
Rated operational voltage U_e according to IEC	V 690 AC ²⁾	690 AC ²⁾	690 AC ²⁾	690 AC ²⁾	690 AC ²⁾	400 AC	690 AC	690 AC
Rated frequency	Hz 50/60	50/60	50/60	50/60	50/60	16 ² / ₃ ... 60	50/60	50/60
Trip class	CLASS 10, 20	CLASS 10	--	CLASS 10	--	--	--	--
Thermal overload release	A 0,11 ... 0,16 up to 80 ... 100	0,11 ... 0,16 up to 80 ... 100	None ³⁾	0,11 ... 0,16 up to 28 ... 40	0,2	1,4 ... 3	0,16 ... 70 non-adjustable	0,16 ... 20 non-adjustable
Electronic release A multiple of the rated current	13 times	13 times	13 times	20 times	6 times	4 ... 7 times	13 times	20 times
Short-circuit breaking capacity I_{cu} at 400 V AC	kA 50/100	50/100	50/100	50/100	100	50	4)	4)
Pages	7/8	7/11	7/12	7/13	7/14	7/17	7/15	7/16

Accessories								
For sizes	S00 S0 S2 S3	S0 S2 S3	S0 S2 S3	S0 S2	S00	S00	S0, S3	S0
Auxiliary switches	✓ ✓ ✓ ✓	✓ ✓ ✓	✓ ✓ ✓	✓ ✓	✓	✓	✓ ⁵⁾	✓ ⁵⁾
Signaling switches	-- ✓ ✓ ✓	✓ ✓ ✓	✓ ✓ ✓	✓ ✓	--	--	--	--
Undervoltage releases	✓ ✓ ✓ ✓	-- -- --	✓ ✓ ✓	✓ ✓	✓	✓	✓	✓
Shunt releases	✓ ✓ ✓ ✓	-- -- --	✓ ✓ ✓	✓ ✓	✓	✓	✓	✓
Isolator modules	-- ✓ ✓ --	✓ ✓ --	✓ ✓ --	✓ ✓	--	--	--	--
Three-phase busbar system	✓ ✓ ✓ --	-- ✓ --	✓ ✓ --	✓ ✓	✓	✓	--	--
Busbar adapters	✓ ✓ ✓ ✓	✓ ✓ ✓	✓ ✓ ✓	✓ ✓	✓	✓	--	--
Rotary operating mechanisms	-- ✓ ✓ ✓	✓ ✓ ✓	✓ ✓ ✓	✓ ✓	--	--	✓	✓
Remote motorized operating mechanisms	-- -- ✓ ✓	-- ✓ ✓	-- ✓ ✓	-- ✓	--	--	--	--
Link modules	✓ ✓ ✓ ✓	✓ ✓ ✓	✓ ✓ ✓	✓ ✓	✓	✓	--	--
Enclosures for surface mounting	✓ ✓ ✓ --	✓ ✓ --	✓ ✓ --	✓ ✓	✓	✓	--	--
Enclosures for flush mounting	✓ ✓ -- --	✓ -- --	✓ -- --	✓ --	✓	✓	--	--
Front plates	✓ ✓ ✓ ✓	✓ ✓ ✓	✓ ✓ ✓	✓ ✓	✓	✓	--	--
Infeed system	✓ ✓ -- --	-- -- --	✓ -- --	✓ --	--	--	--	--
Pages	7/18 ... 7/36							

✓ Has this function or can use this accessory
 -- Does not have this function or cannot use this accessory

¹⁾ For symmetrical loading of the three phases.

²⁾ With molded-plastic enclosure 500 V AC. DC applications see "Technical Specifications" → "DC Short-Circuit Breaking Capacity" in Catalog IC 10 · 2012.

³⁾ For overload protection of the motors, appropriate overload relays must be used.

⁴⁾ According to UL 489
 - at 480 Y/277 V AC: For size S0 50 kA, for size S3 65 kA;
 - at 480 V AC: for size S3 (10 to 30 A) 65 kA.

⁵⁾ Only lateral auxiliary switches can be fitted.



Type	3RV10			3RV13						
SIRIUS 3RV1 molded case motor starter protectors up to 800 A¹⁾										
Applications										
Motor protection	✓			--						
Starter combinations	--			✓						
Switching capacity	Standard switching capacity			Standard switching capacity						Increased switching capacity
Size	3RV10 63	3RV10 73	3RV10 83	3RV13 53	3RV13 63	3RV13 73	3RV13 83	3RV13 64	3RV13 74	
Rated current I_n	A 100 ... 200	400	630	1 ... 32	100 ... 250	400, 630	630, 800	100 ... 250	400	
Rated operational voltage U_e according to IEC	690 AC			690 AC						
Rated frequency	Hz 50/60			50/60						
Trip class	CLASS 10A, 10, 20, 30			-- ¹⁾						
Thermal overload release	A 40 ... 100 up to A 252 ... 630			None ¹⁾						
Electronic release A multiple of the rated current	Adjustable, 6 ... 13 times			Non-adjustable 1 ... 12.5 A: 13 times Adjustable 20 A, 32 A: 6 ... 12 times	1 ... 10 times					
Short-circuit breaking capacity I_{cu} at 400 V AC	kA 120	120	100	85	120	120	100	200	200	
Trip unit	TU 4			TU 1: 1 ... 12.5 A TU 2: 20 A, 32 A	TU 3					

Accessories¹⁾									
For molded case motor starter protectors	3RV10 63	3RV10 73	3RV10 83	3RV13 53	3RV13 63	3RV13 73	3RV13 83	3RV13 64	3RV13 74
Auxiliary switches	✓	✓	✓	✓	✓	✓	✓	✓	✓
Undervoltage releases	✓	✓	✓	✓	✓	✓	✓	✓	✓
Shunt releases	✓	✓	✓	✓	✓	✓	✓	✓	✓
Rotary operating mechanisms	✓	✓	✓	✓	✓	✓	✓	✓	✓
Connection methods									
• Front-extended terminals	✓	✓	--	✓	✓	✓	--	✓	✓
• Front-accessible cable terminals	✓	✓	✓	✓	✓	✓	✓	✓	✓
• Rear terminals	✓	✓	✓	✓	✓	✓	✓	✓	✓

✓ = Has this function or can use this accessory

-- = Does not have this function or cannot use this accessory

¹⁾ More information see Catalog IC 10 · 2012.²⁾ For overload protection of the motors, appropriate overload relays must be used.

Introduction



Type		3RU11	3RB20	3RB21	3RB22, 3RB23
SIRIUS overload relays up to 630 A					
Applications					
System protection		✓ ¹⁾	✓ ¹⁾	✓ ¹⁾	✓ ¹⁾
Motor protection		✓	✓	✓	✓
Alternating current, three-phase		✓	✓	✓	✓
Alternating current, single-phase		✓	--	--	✓
Direct current		✓	--	--	--
Size of contactor		S00, S0, S2, S3	S00 ... S12	S00 ... S12	S00 ... S12
Rated operational current I_e					
• Size S00	A	Up to 12	Up to 12	Up to 12	Up to 25
• Size S0	A	Up to 25	Up to 25	Up to 25	Up to 25
• Size S2	A	Up to 50	Up to 50	Up to 50	Up to 100
• Size S3	A	Up to 100	Up to 100	Up to 100	Up to 100
• Size S6	A	--	Up to 200	Up to 200	Up to 200
• Size S10/S12, size 14 (3TF68/3TF69)	A	--	Up to 630	Up to 630	Up to 630
Rated operational voltage U_e	V	690/1 000 AC ²⁾	690/1 000 AC ³⁾	690/1 000 AC ³⁾	690/1 000 AC ⁴⁾
Rated frequency	Hz	50/60	50/60	50/60	50/60
Trip class		CLASS 10	CLASS 10, 20	CLASS 5, 10, 20, 30 Adjustable	CLASS 5, 10, 20, 30 Adjustable
Thermal overload releases	A	0,11 ... 0,16 up to 80 ... 100	--	--	--
Electronic overload releases	A	--	0,1 ... 0,4 up to 160 ... 630	0,1 ... 0,4 up to 160 ... 630	0,3 ... 3 up to 63 ... 630
Rating for induction motor at 400 V AC	kW	0,04 to 45	0,04 ... 0,09 up to 90 ... 450	0,04 ... 0,09 up to 90 ... 450	0,09 ... 1,1 up to 37 ... 450
Pages		7/43 ... 7/45	7/50, 7/51	7/52	7/57 ... 7/59
Accessories					
For sizes		S00 S0 S2 S3	S00 S0 S2 S3 S6 S10/S12	S00 S0 S2 S3 S6 S10/S12	S00 S0 S2 S3 S6 S10/S12
Terminal brackets for stand-alone installation		✓ ✓ ✓ ✓	✓ ✓ ⁵⁾ ⁵⁾ ⁵⁾ ⁵⁾	✓ ✓ ⁵⁾ ⁵⁾ ⁵⁾ ⁵⁾	5) 5) 5) 5) 5) 5)
Mechanical RESET		✓ ✓ ✓ ✓	✓ ✓ ✓ ✓ ✓ ✓	✓ ✓ ✓ ✓ ✓ ✓	-- -- -- -- -- --
Cable releases for RESET		✓ ✓ ✓ ✓	✓ ✓ ✓ ✓ ✓ ✓	✓ ✓ ✓ ✓ ✓ ✓	-- -- -- -- -- --
Electrical remote RESET		✓ ✓ ✓ ✓	-- -- -- -- -- --	Integrated in the unit	Integrated in the unit
Terminal covers		-- -- ✓ ✓	-- -- -- ✓ ✓ ✓	-- -- -- ✓ ✓ ✓	-- -- -- ✓ ✓ ✓
Sealable covers for setting knobs		Integrated in the unit	✓ ✓ ✓ ✓ ✓ ✓	✓ ✓ ✓ ✓ ✓ ✓	✓ ✓ ✓ ✓ ✓ ✓
Pages		7/46, 7/47	7/53, 7/54	7/53, 7/54	7/60, 7/61

✓ Has this function or can use this accessory

-- Does not have this function or cannot use this accessory

¹⁾ The units are responsible in the main circuit for overload protection of the assigned electrical loads (e. g. motors), feeder cable and other switching and protection devices in the respective load feeder.

²⁾ Size S3 up to 1 000 V AC.

³⁾ Size S2 (only with straight-through transformer), S3, S6, S10, S12 up to 1 000 V AC.

⁴⁾ With reference to the 3RB29 .6 current measuring modules.

⁵⁾ Stand-alone installation without accessories is possible.

Motor Starter Protectors

SIRIUS 3RV1 motor starter protectors up to 100 A

General data

Overview

The following illustration shows our 3RV1 motor starter protectors with the accessories which can be mounted for the various sizes, see also "Introduction" → "Overview" on page 7/2.

"Accessories" see page 7/18 onwards.

Motor starter protectors/circuit breakers, size S00, with mountable accessories

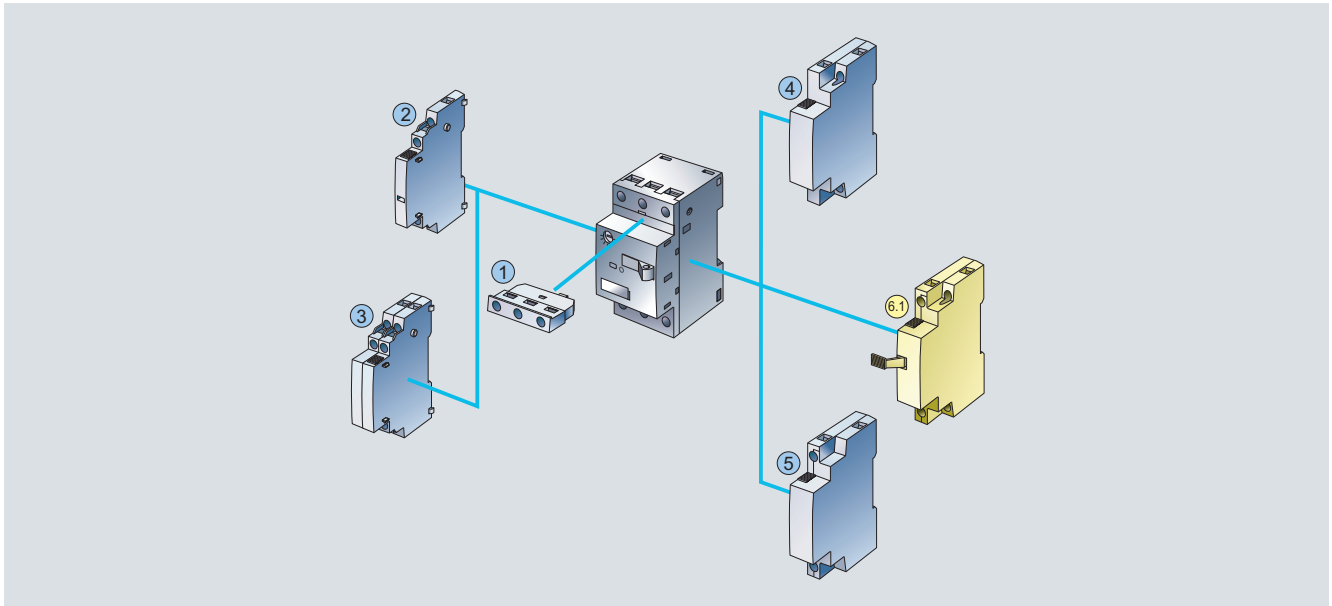

Motor starter protectors/circuit breakers, sizes S0, S2 or S3, with mountable accessories

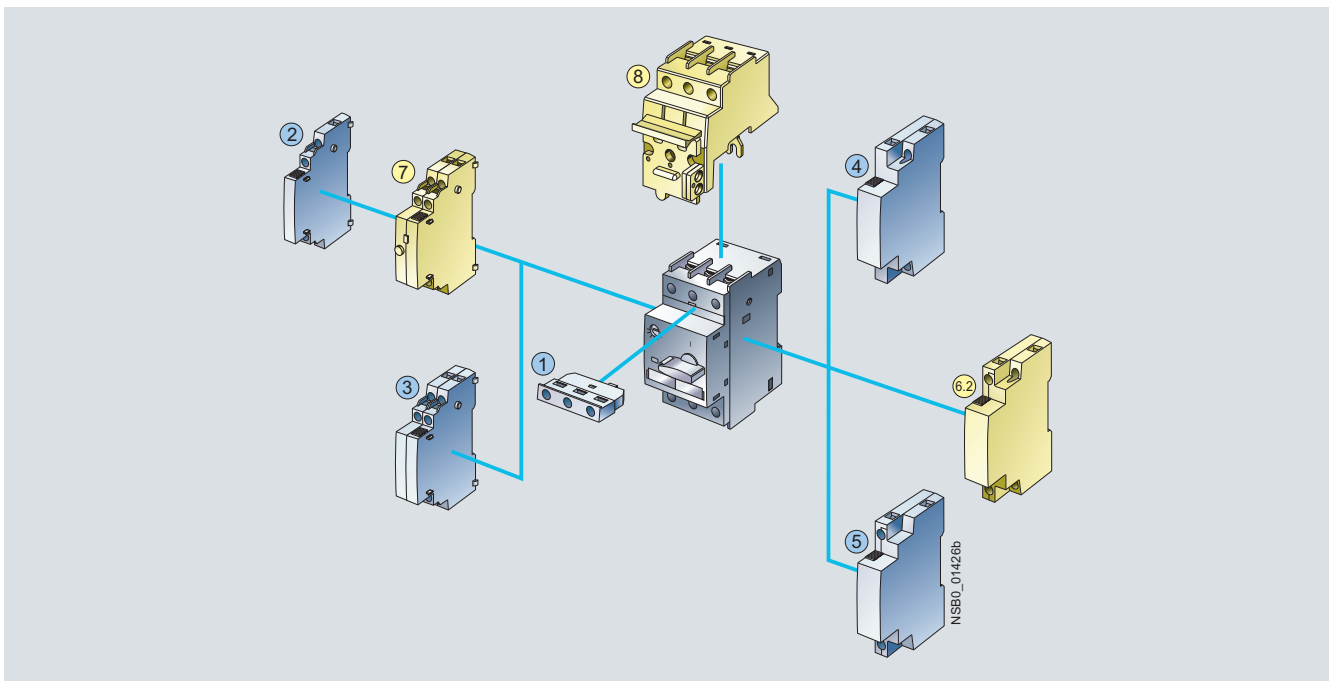

Mountable accessories for all sizes S00 ... S3

- ① Transverse auxiliary switch (can not be used with 3RV17 and 3RV18 circuit breakers)
- ② Lateral auxiliary switch with 2 contacts
- ③ Lateral auxiliary switch with 4 contacts
- ④ Shunt release
- ⑤ Undervoltage release

Mountable accessories

- ⑥.1 Undervoltage release with leading auxiliary contacts
- ⑥.2 Undervoltage release with leading auxiliary contacts
- ⑦ Alarm switch
- ⑧ Isolator module

For sizes

- S00
- S0 ... S3
- S0 ... S3
- S0, S2

Motor Starter Protectors

SIRIUS 3RV1 motor starter protectors up to 100 A

General data



Size S0 motor starter protector

3RV1 motor starter protectors are compact, current limiting motor starter protectors which are optimized for load feeders. The motor starter protectors are used in accordance with IEC 60947 for switching and protecting three-phase induction motors of up to 45 kW at 400 V AC and for other loads with rated currents of up to 100 A.

The 3RV1 motor starter protectors are generally approved according to IEC and UL/CSA.

According to UL 508 the 3RV1 motor starter protectors in sizes S00 to S3 are approved as

- "Manual motor controllers"
- "Manual Motor Controllers" for "Group Installations"
- "Manual Motor Controllers Suitable for Tab Conductor Protection in Group Installations"
- "Self-Protected Combination Motor Controller (Type E)" This approval does not apply to size S00. Furthermore, the 3RV10 motor starter protectors in sizes S0 and S3 must be equipped with additional feeder terminals.

3RV2 motor starter protectors in sizes S00 and S0 up to 40 A [see Catalog IC 10 · 2012](#).

The 3RV17 and 3RV18 are approved as circuit breakers according to UL 489; they are a special variant of the 3RV1 motor starter protectors.

Type of construction

The 3RV1 motor starter protectors are available in four sizes:

- Size S00 - width 45 mm, max. rated current 12 A, at 400 V AC suitable for induction motors up to 5.5 kW
- Size S0 - width 45 mm, max. rated current 25 A, at 400 V AC suitable for induction motors up to 11 kW
- Size S2 - width 55 mm, max. rated current 50 A, at 400 V AC suitable for induction motors up to 22 kW
- Size S3 - width 70 mm, max. rated current 100 A, at 400 V AC suitable for induction motors up to 45 kW

3RV2 motor starter protectors in sizes S00 and S0 up to 40 A [see Catalog IC 10 · 2012](#).

Circuit breakers acc. to UL 489

The 3RV17 and 3RV18 circuit breakers are available two sizes:

- Size S0 - width 45 mm
3RV17 21: max. rated current 22 A at 480 Y/277 V AC
3RV18 21: max. rated current 20 A at 480 Y/277 V AC
- Size S3 - width 70 mm
3RV17 42: max. rated current 70 A at 480 Y/277 V AC, max. rated current 10 A to 30 A at 480 V AC.

3RV27 and 3RV28 circuit breakers in size S00 up to 15 A [see Catalog IC 10 · 2012](#).

Connection methods

The SIRIUS 3RV1 motor starter protectors can be supplied with screw terminals or spring-type terminals.



Screw terminals



Spring-type terminals

The terminals are indicated in the corresponding tables by the symbols shown on orange backgrounds.

"Increased safety" type of protection EEx e according to ATEX directive 94/9/EC

3RV10 motor starter protectors are suitable for overload protection of explosion-protected motors with "increased safety" type of protection EEx e;

[see www.siemens.com/sirius/atex](http://www.siemens.com/sirius/atex).

Order No. scheme

Digit of the Order No.	1. - 3.	4.	5.	6.	7.	8.	9.	10.	11.	12.	13.	14.	15.	16.	
	□□□	□	□	□	□	-	□	□	□	□	-	□	□	□	
Motor starter protectors	3 R V														
SIRIUS 1st generation	1														
Type of motor starter protector	□														
Size	□														
Switching capacity	□														
Setting range for overload release	□ □														
Trip class (CLASS)	□														
Connection methods	□														
With or without auxiliary switch	□														
Special versions	□ □ □ □														
Example	3	R	V	1	0	3	1	-	4	A	A	1	0		

Note:

The Order No. scheme is presented here merely for information purposes and for better understanding of the logic behind the order numbers.

For your orders, please use the order numbers quote in the catalog in the Selection and ordering data.

Motor Starter Protectors

SIRIUS 3RV1 motor starter protectors up to 100 A

General data

Application

Operating conditions

3RV1 motor starter protectors are suitable for use in any climate. They are intended for use in enclosed rooms in which no severe operating conditions (such as dust, caustic vapors, hazardous gases) prevail. When installed in dusty and damp areas, suitable enclosures must be provided.

3RV1 motor starter protectors can optionally be fed from the top or from below.

The permissible ambient temperatures, the maximum switching capacities, the tripping currents and other boundary conditions can be found in the technical specifications and tripping characteristics, see ["Reference Manual for Protection Equipment – Motor Starter Protectors · 3RV1 Molded Case Motor Starter Protectors"](#).

3RV1 motor starter protectors are suitable for operation in IT systems (IT networks). In this case, the different short-circuit breaking capacity in the IT system must be taken into account.

Since operational currents, starting currents and current peaks are different even for motors with identical power ratings due to the inrush current, the motor ratings in the selection tables are only guide values. The specific rated and start-up data of the motor to be protected is always paramount to the choice of the most suitable motor starter protector. This also applies to motor starter protectors for transformer protection.

Possible uses

The 3RV1 motor starter protectors can be used:

- For short-circuit protection
- For motor protection (also with overload relay function)
- For system protection
- For short-circuit protection for starter combinations
- For transformer protection
- As main and EMERGENCY-STOP switches
- For fuse monitoring
- For operation in IT systems (IT networks)
- For switching of DC currents
- As voltage transformer circuit breakers
- In areas subject to explosion hazard (ATEX)
- As circuit breakers according to UL 489 (3RV17 and 3RV18)

More details see ["Reference Manual for Protection Equipment – Motor Starter Protectors · 3RV1 Molded Case Motor Starter Protectors"](#).

Motor Starter Protectors

SIRIUS 3RV1 motor starter protectors up to 100 A

For motor protection

Selection and ordering data

CLASS 10, without auxiliary switches

PU (UNIT, SET, M) = 1
 PS* = 1 unit
 PG = 41E

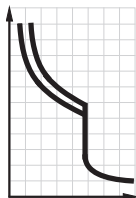

3RV10 11-0JA10



3RV10 21-0JA10



3RV10 11-1EA20

Rated current	Suitable for three-phase induction motors ¹⁾ with P	Setting range for thermal overload release	Instantaneous over-current release	Short-circuit breaking capacity at 400 V AC	DT	Screw terminals	DT	Spring-type terminals	
I_n				I_{cu}		Order No.	Price € per PU	Order No.	Price € per PU
A	kW	A	A	kA					
Size S00									
0,16	0,04	0,11 ... 0,16	2,1	100	▶	3RV10 11-0AA10	▶	3RV10 11-0AA20	
0,2	0,06	0,14 ... 0,2	2,6	100	▶	3RV10 11-0BA10	▶	3RV10 11-0BA20	
0,25	0,06	0,18 ... 0,25	3,3	100	▶	3RV10 11-0CA10	▶	3RV10 11-0CA20	
0,32	0,09	0,22 ... 0,32	4,2	100	▶	3RV10 11-0DA10	▶	3RV10 11-0DA20	
0,4	0,09	0,28 ... 0,4	5,2	100	▶	3RV10 11-0EA10	▶	3RV10 11-0EA20	
0,5	0,12	0,35 ... 0,5	6,5	100	▶	3RV10 11-0FA10	▶	3RV10 11-0FA20	
0,63	0,18	0,45 ... 0,63	8,2	100	▶	3RV10 11-0GA10	▶	3RV10 11-0GA20	
0,8	0,18	0,55 ... 0,8	10	100	▶	3RV10 11-0HA10	▶	3RV10 11-0HA20	
1	0,25	0,7 ... 1	13	100	▶	3RV10 11-0JA10	▶	3RV10 11-0JA20	
1,25	0,37	0,9 ... 1,25	16	100	▶	3RV10 11-0KA10	▶	3RV10 11-0KA20	
1,6	0,55	1,1 ... 1,6	21	100	▶	3RV10 11-1AA10	▶	3RV10 11-1AA20	
2	0,75	1,4 ... 2	26	100	▶	3RV10 11-1BA10	▶	3RV10 11-1BA20	
2,5	0,75	1,8 ... 2,5	33	100	▶	3RV10 11-1CA10	▶	3RV10 11-1CA20	
3,2	1,1	2,2 ... 3,2	42	100	▶	3RV10 11-1DA10	▶	3RV10 11-1DA20	
4	1,5	2,8 ... 4	52	100	▶	3RV10 11-1EA10	▶	3RV10 11-1EA20	
5	1,5	3,5 ... 5	65	100	▶	3RV10 11-1FA10	▶	3RV10 11-1FA20	
6,3	2,2	4,5 ... 6,3	82	100	▶	3RV10 11-1GA10	▶	3RV10 11-1GA20	
8	3	5,5 ... 8	104	50	▶	3RV10 11-1HA10	▶	3RV10 11-1HA20	
10	4	7 ... 10	130	50	▶	3RV10 11-1JA10	▶	3RV10 11-1JA20	
12	5,5	9 ... 12	156	50	▶	3RV10 11-1KA10	▶	3RV10 11-1KA20	
Size S0									
0,16	0,04	0,11 ... 0,16	2,1	100	▶	3RV10 21-0AA10		--	
0,2	0,06	0,14 ... 0,2	2,6	100	▶	3RV10 21-0BA10		--	
0,25	0,06	0,18 ... 0,25	3,3	100	▶	3RV10 21-0CA10		--	
0,32	0,09	0,22 ... 0,32	4,2	100	▶	3RV10 21-0DA10		--	
0,4	0,09	0,28 ... 0,4	5,2	100	▶	3RV10 21-0EA10		--	
0,5	0,12	0,35 ... 0,5	6,5	100	▶	3RV10 21-0FA10		--	
0,63	0,18	0,45 ... 0,63	8,2	100	▶	3RV10 21-0GA10		--	
0,8	0,18	0,55 ... 0,8	10	100	▶	3RV10 21-0HA10		--	
1	0,25	0,7 ... 1	13	100	▶	3RV10 21-0JA10		--	
1,25	0,37	0,9 ... 1,25	16	100	▶	3RV10 21-0KA10		--	
1,6	0,55	1,1 ... 1,6	21	100	▶	3RV10 21-1AA10		--	
2	0,75	1,4 ... 2	26	100	▶	3RV10 21-1BA10		--	
2,5	0,75	1,8 ... 2,5	33	100	▶	3RV10 21-1CA10		--	
3,2	1,1	2,2 ... 3,2	42	100	▶	3RV10 21-1DA10		--	
4	1,5	2,8 ... 4	52	100	▶	3RV10 21-1EA10		--	
5	1,5	3,5 ... 5	65	100	▶	3RV10 21-1FA10		--	
6,3	2,2	4,5 ... 6,3	82	100	▶	3RV10 21-1GA10		--	
8	3	5,5 ... 8	104	100	▶	3RV10 21-1HA10		--	
10	4	7 ... 10	130	100	▶	3RV10 21-1JA10		--	
12,5	5,5	9 ... 12,5	163	100	▶	3RV10 21-1KA10		--	
16	7,5	11 ... 16	208	50	▶	3RV10 21-4AA10		--	
20	7,5	14 ... 20	260	50	▶	3RV10 21-4BA10		--	
22	11	17 ... 22	286	50	▶	3RV10 21-4CA10		--	
25	11	20 ... 25	325	50	▶	3RV10 21-4DA10		--	

¹⁾ Guide value for 4-pole standard motors at 50 Hz 400 V AC. The actual starting and rated data of the motor to be protected must be considered when selecting the units.

Auxiliary switches and other accessories can be ordered separately (see "Mountable Accessories" on page 7/18 onwards).

Multi-unit packing and reusable packaging on request.

Motor Starter Protectors

SIRIUS 3RV1 motor starter protectors up to 100 A

For motor protection

CLASS 10, with transverse auxiliary switch (1 NO + 1 NC)

PU (UNIT, SET, M) = 1
 PS* = 1 unit
 PG = 41E

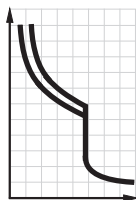

3RV10 11-0KA15 with integrated transverse auxiliary switch



3RV10 21-1GA15 with integrated transverse auxiliary switch



3RV10 11-0GA25 with integrated transverse auxiliary switch

Rated current	Suitable for three-phase induction motors ¹⁾ with P	Setting range for thermal overload release	Instantaneous over-current release	Short-circuit breaking capacity at 400 V AC	DT	Screw terminals	DT	Spring-type terminals	
I_n			$I >$	I_{cu}		Order No.	Price € per PU	Order No.	Price € per PU
A	kW	A	A	kA					
Size S00									
0,16	0,04	0,11 ... 0,16	2,1	100	▶	3RV10 11-0AA15	B	3RV10 11-0AA25	
0,2	0,06	0,14 ... 0,2	2,6	100	▶▶	3RV10 11-0BA15	B	3RV10 11-0BA25	
0,25	0,06	0,18 ... 0,25	3,3	100	▶▶▶	3RV10 11-0CA15	B	3RV10 11-0CA25	
0,32	0,09	0,22 ... 0,32	4,2	100	▶▶▶▶	3RV10 11-0DA15	B	3RV10 11-0DA25	
0,4	0,09	0,28 ... 0,4	5,2	100	▶▶▶▶▶	3RV10 11-0EA15	B	3RV10 11-0EA25	
0,5	0,12	0,35 ... 0,5	6,5	100	▶▶▶▶▶▶	3RV10 11-0FA15	B	3RV10 11-0FA25	
0,63	0,18	0,45 ... 0,63	8,2	100	▶▶▶▶▶▶▶	3RV10 11-0GA15	B	3RV10 11-0GA25	
0,8	0,18	0,55 ... 0,8	10	100	▶▶▶▶▶▶▶▶	3RV10 11-0HA15	B	3RV10 11-0HA25	
1	0,25	0,7 ... 1	13	100	▶▶▶▶▶▶▶▶▶	3RV10 11-0JA15	B	3RV10 11-0JA25	
1,25	0,37	0,9 ... 1,25	16	100	▶▶▶▶▶▶▶▶▶▶	3RV10 11-0KA15	B	3RV10 11-0KA25	
1,6	0,55	1,1 ... 1,6	21	100	▶▶▶▶▶▶▶▶▶▶▶	3RV10 11-1AA15	B	3RV10 11-1AA25	
2	0,75	1,4 ... 2	26	100	▶▶▶▶▶▶▶▶▶▶▶▶	3RV10 11-1BA15	B	3RV10 11-1BA25	
2,5	0,75	1,8 ... 2,5	33	100	▶▶▶▶▶▶▶▶▶▶▶▶▶	3RV10 11-1CA15	B	3RV10 11-1CA25	
3,2	1,1	2,2 ... 3,2	42	100	▶▶▶▶▶▶▶▶▶▶▶▶▶▶	3RV10 11-1DA15	B	3RV10 11-1DA25	
4	1,5	2,8 ... 4	52	100	▶▶▶▶▶▶▶▶▶▶▶▶▶▶▶	3RV10 11-1EA15	B	3RV10 11-1EA25	
5	1,5	3,5 ... 5	65	100	▶▶▶▶▶▶▶▶▶▶▶▶▶▶▶▶	3RV10 11-1FA15	B	3RV10 11-1FA25	
6,3	2,2	4,5 ... 6,3	82	100	▶▶▶▶▶▶▶▶▶▶▶▶▶▶▶▶▶	3RV10 11-1GA15	B	3RV10 11-1GA25	
8	3	5,5 ... 8	104	50	▶▶▶▶▶▶▶▶▶▶▶▶▶▶▶▶▶▶	3RV10 11-1HA15	B	3RV10 11-1HA25	
10	4	7 ... 10	130	50	▶▶▶▶▶▶▶▶▶▶▶▶▶▶▶▶▶▶▶	3RV10 11-1JA15	B	3RV10 11-1JA25	
12	5,5	9 ... 12	156	50	▶▶▶▶▶▶▶▶▶▶▶▶▶▶▶▶▶▶▶▶	3RV10 11-1KA15	B	3RV10 11-1KA25	
Size S0									
0,16	0,04	0,11 ... 0,16	2,1	100	▶	3RV10 21-0AA15		--	
0,2	0,06	0,14 ... 0,2	2,6	100	▶▶	3RV10 21-0BA15		--	
0,25	0,06	0,18 ... 0,25	3,3	100	▶▶▶	3RV10 21-0CA15		--	
0,32	0,09	0,22 ... 0,32	4,2	100	▶▶▶▶	3RV10 21-0DA15		--	
0,4	0,09	0,28 ... 0,4	5,2	100	▶▶▶▶▶	3RV10 21-0EA15		--	
0,5	0,12	0,35 ... 0,5	6,5	100	▶▶▶▶▶▶	3RV10 21-0FA15		--	
0,63	0,18	0,45 ... 0,63	8,2	100	▶▶▶▶▶▶▶	3RV10 21-0GA15		--	
0,8	0,18	0,55 ... 0,8	10	100	▶▶▶▶▶▶▶▶	3RV10 21-0HA15		--	
1	0,25	0,7 ... 1	13	100	▶▶▶▶▶▶▶▶	3RV10 21-0JA15		--	
1,25	0,37	0,9 ... 1,25	16	100	▶▶▶▶▶▶▶▶▶	3RV10 21-0KA15		--	
1,6	0,55	1,1 ... 1,6	21	100	▶▶▶▶▶▶▶▶▶▶	3RV10 21-1AA15		--	
2	0,75	1,4 ... 2	26	100	▶▶▶▶▶▶▶▶▶▶▶	3RV10 21-1BA15		--	
2,5	0,75	1,8 ... 2,5	33	100	▶▶▶▶▶▶▶▶▶▶▶▶	3RV10 21-1CA15		--	
3,2	1,1	2,2 ... 3,2	42	100	▶▶▶▶▶▶▶▶▶▶▶▶▶	3RV10 21-1DA15		--	
4	1,5	2,8 ... 4	52	100	▶▶▶▶▶▶▶▶▶▶▶▶▶▶	3RV10 21-1EA15		--	
5	1,5	3,5 ... 5	65	100	▶▶▶▶▶▶▶▶▶▶▶▶▶▶▶	3RV10 21-1FA15		--	
6,3	2,2	4,5 ... 6,3	82	100	▶▶▶▶▶▶▶▶▶▶▶▶▶▶▶▶	3RV10 21-1GA15		--	
8	3	5,5 ... 8	104	100	▶▶▶▶▶▶▶▶▶▶▶▶▶▶▶▶▶	3RV10 21-1HA15		--	
10	4	7 ... 10	130	100	▶▶▶▶▶▶▶▶▶▶▶▶▶▶▶▶▶▶	3RV10 21-1JA15		--	
12,5	5,5	9 ... 12,5	163	100	▶▶▶▶▶▶▶▶▶▶▶▶▶▶▶▶▶▶▶	3RV10 21-1KA15		--	
16	7,5	11 ... 16	208	50	▶▶▶▶▶▶▶▶▶▶▶▶▶▶▶▶▶▶▶▶	3RV10 21-4AA15		--	
20	7,5	14 ... 20	260	50	▶▶▶▶▶▶▶▶▶▶▶▶▶▶▶▶▶▶▶▶▶	3RV10 21-4BA15		--	
22	11	17 ... 22	286	50	▶▶▶▶▶▶▶▶▶▶▶▶▶▶▶▶▶▶▶▶▶▶	3RV10 21-4CA15		--	
25	11	20 ... 25	325	50	▶▶▶▶▶▶▶▶▶▶▶▶▶▶▶▶▶▶▶▶▶▶▶	3RV10 21-4DA15		--	

¹⁾ Guide value for 4-pole standard motors at 50 Hz 400 V AC. The actual starting and rated data of the motor to be protected must be considered when selecting the units.

Auxiliary switches and other accessories can be ordered separately (see "Mountable Accessories" on page 7/18 onwards).

Multi-unit packing and reusable packaging on request.

Motor Starter Protectors

SIRIUS 3RV1 motor starter protectors up to 100 A

For motor protection

CLASS 10, without auxiliary switches

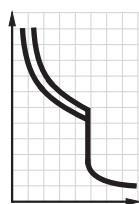

Rated current	Suitable for three-phase induction motors ¹⁾ with P	Setting range for thermal overload release	Instantaneous over-current release	Short-circuit breaking capacity at 400 V AC	DT	Screw terminals	⊕	PU (UNIT, SET, M)	PS*	PG
I_n			$I >$	I_{cu}		Order No.	Price € per PU			
A	kW	A	A	kA						

Size S2



16	7,5	11 ... 16	208	50	▶	3RV10 31-4AA10		1	1 unit	41E
20	7,5	14 ... 20	260	50	▶	3RV10 31-4BA10		1	1 unit	41E
25	11	18 ... 25	325	50	▶	3RV10 31-4DA10		1	1 unit	41E
32	15	22 ... 32	416	50	▶	3RV10 31-4EA10		1	1 unit	41E
40	18,5	28 ... 40	520	50	▶	3RV10 31-4FA10		1	1 unit	41E
45	22	36 ... 45	585	50	▶	3RV10 31-4GA10		1	1 unit	41E
50	22	40 ... 50	650	50	▶	3RV10 31-4HA10		1	1 unit	41E

3RV10 31-4HA10

Size S3



40	18,5	28 ... 40	520	50	▶	3RV10 41-4FA10		1	1 unit	41E
50	22	36 ... 50	650	50	▶	3RV10 41-4HA10		1	1 unit	41E
63	30	45 ... 63	819	50	▶	3RV10 41-4JA10		1	1 unit	41E
75	37	57 ... 75	975	50	▶	3RV10 41-4KA10		1	1 unit	41E
90	45	70 ... 90	1 170	50	▶	3RV10 41-4LA10		1	1 unit	41E
100	45	80 ... 100	1 235	50	▶	3RV10 41-4MA10		1	1 unit	41E

3RV10 41-4LA10

Size S3, with increased switching capacity



16	7,5	11 ... 16	208	100	▶	3RV10 42-4AA10		1	1 unit	41E
20	7,5	14 ... 20	260	100	▶	3RV10 42-4BA10		1	1 unit	41E
25	11	18 ... 25	325	100	▶	3RV10 42-4DA10		1	1 unit	41E
32	15	22 ... 32	416	100	▶	3RV10 42-4EA10		1	1 unit	41E
40	18,5	28 ... 40	520	100	▶	3RV10 42-4FA10		1	1 unit	41E
50	22	36 ... 50	650	100	▶	3RV10 42-4HA10		1	1 unit	41E
63	30	45 ... 63	819	100	▶	3RV10 42-4JA10		1	1 unit	41E
75	37	57 ... 75	975	100	▶	3RV10 42-4KA10		1	1 unit	41E
90	45	70 ... 90	1 170	100	▶	3RV10 42-4LA10		1	1 unit	41E
100	45	80 ... 100	1 235	100	▶	3RV10 42-4MA10		1	1 unit	41E

3RV10 42-4JA10

CLASS 20, without auxiliary switches

Size S2



16	7,5	11 ... 16	208	50	A	3RV10 31-4AB10		1	1 unit	41E
20	7,5	14 ... 20	260	50	A	3RV10 31-4BB10		1	1 unit	41E
25	11	18 ... 25	325	50	A	3RV10 31-4DB10		1	1 unit	41E
32	15	22 ... 32	416	50	A	3RV10 31-4EB10		1	1 unit	41E
40	18,5	28 ... 40	520	50	A	3RV10 31-4FB10		1	1 unit	41E
45	22	36 ... 45	585	50	A	3RV10 31-4GB10		1	1 unit	41E
50	22	40 ... 50	650	50	A	3RV10 31-4HB10		1	1 unit	41E

3RV10 31-4AB10

Size S3, with increased switching capacity



40	18,5	28 ... 40	520	100	A	3RV10 42-4FB10		1	1 unit	41E
50	22	36 ... 50	650	100	A	3RV10 42-4HB10		1	1 unit	41E
63	30	45 ... 63	819	100	A	3RV10 42-4JB10		1	1 unit	41E
75	37	57 ... 75	975	100	A	3RV10 42-4KB10		1	1 unit	41E
90	45	70 ... 90	1 170	100	A	3RV10 42-4LB10		1	1 unit	41E
100	45	80 ... 100	1 235	100	A	3RV10 42-4MB10		1	1 unit	41E

3RV10 42-4KB10

¹⁾ Guide value for 4-pole standard motors at 50 Hz 400 V AC. The actual starting and rated data of the motor to be protected must be considered when selecting the units.

Auxiliary switches and other accessories can be ordered separately (see "Mountable Accessories" on page 7/18 onwards).

Multi-unit packing and reusable packaging
see Catalog IC 10 · 2012.





Motor Starter Protectors

SIRIUS 3RV1 motor starter protectors up to 100 A

For motor protection with overload relay function

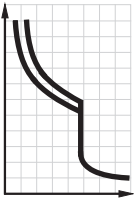
Selection and ordering data

CLASS 10, with overload relay function (automatic RESET), without auxiliary switches

	Rated current	Suitable for three-phase induction motors ¹⁾ with P	Setting range for thermal overload release	Instantaneous over-current release	Short-circuit breaking capacity at 400 V AC	DT	Screw terminals	⊕	PU (UNIT, SET, M)	PS*	PG
	I_n			$I >$	I_{cu}		Order No.		Price € per PU		
Size S0 ²⁾											
 3RV11 21-0KA10	0,16	0,04	0,11 ... 0,16	2,1	100	A	3RV11 21-0AA10		1	1 unit	41E
	0,2	0,06	0,14 ... 0,2	2,6	100	A	3RV11 21-0BA10		1	1 unit	41E
	0,25	0,06	0,18 ... 0,25	3,3	100	A	3RV11 21-0CA10		1	1 unit	41E
	0,32	0,09	0,22 ... 0,32	4,2	100	A	3RV11 21-0DA10		1	1 unit	41E
	0,4	0,09	0,28 ... 0,4	5,2	100	A	3RV11 21-0EA10		1	1 unit	41E
	0,5	0,12	0,35 ... 0,5	6,5	100	A	3RV11 21-0FA10		1	1 unit	41E
	0,63	0,18	0,45 ... 0,63	8,2	100	A	3RV11 21-0GA10		1	1 unit	41E
	0,8	0,18	0,55 ... 0,8	10	100	A	3RV11 21-0HA10		1	1 unit	41E
	1	0,25	0,7 ... 1	13	100	A	3RV11 21-0JA10		1	1 unit	41E
	1,25	0,37	0,9 ... 1,25	16	100	A	3RV11 21-0KA10		1	1 unit	41E
	1,6	0,55	1,1 ... 1,6	21	100	A	3RV11 21-1AA10		1	1 unit	41E
	2	0,75	1,4 ... 2	26	100	A	3RV11 21-1BA10		1	1 unit	41E
	2,5	0,75	1,8 ... 2,5	33	100	A	3RV11 21-1CA10		1	1 unit	41E
	3,2	1,1	2,2 ... 3,2	42	100	A	3RV11 21-1DA10		1	1 unit	41E
	4	1,5	2,8 ... 4	52	100	A	3RV11 21-1EA10		1	1 unit	41E
	5	1,5	3,5 ... 5	65	100	A	3RV11 21-1FA10		1	1 unit	41E
6,3	2,2	4,5 ... 6,3	82	100	A	3RV11 21-1GA10		1	1 unit	41E	
8	3	5,5 ... 8	104	100	A	3RV11 21-1HA10		1	1 unit	41E	
10	4	7 ... 10	130	100	A	3RV11 21-1JA10		1	1 unit	41E	
12,5	5,5	9 ... 12,5	163	100	A	3RV11 21-1KA10		1	1 unit	41E	
16	7,5	11 ... 16	208	50	A	3RV11 21-4AA10		1	1 unit	41E	
20	7,5	14 ... 20	260	50	A	3RV11 21-4BA10		1	1 unit	41E	
22	11	17 ... 22	286	50	A	3RV11 21-4CA10		1	1 unit	41E	
25	11	20 ... 25	325	50	A	3RV11 21-4DA10		1	1 unit	41E	
Size S2 ²⁾											
 3RV11 31-4EA10	16	7,5	11 ... 16	208	50	A	3RV11 31-4AA10		1	1 unit	41E
	20	7,5	14 ... 20	260	50	A	3RV11 31-4BA10		1	1 unit	41E
	25	11	18 ... 25	325	50	A	3RV11 31-4DA10		1	1 unit	41E
	32	15	22 ... 32	416	50	A	3RV11 31-4EA10		1	1 unit	41E
	40	18,5	28 ... 40	520	50	A	3RV11 31-4FA10		1	1 unit	41E
	45	22	36 ... 45	585	50	A	3RV11 31-4GA10		1	1 unit	41E
	50	22	40 ... 50	650	50	A	3RV11 31-4HA10		1	1 unit	41E
	Size S3, with increased switching capacity ²⁾										
 3RV11 42-4AA10	16	7,5	11 ... 16	208	100	A	3RV11 42-4AA10		1	1 unit	41E
	20	7,5	14 ... 20	260	100	A	3RV11 42-4BA10		1	1 unit	41E
	25	11	18 ... 25	325	100	A	3RV11 42-4DA10		1	1 unit	41E
	32	15	22 ... 32	416	100	A	3RV11 42-4EA10		1	1 unit	41E
	40	18,5	28 ... 40	520	100	A	3RV11 42-4FA10		1	1 unit	41E
	50	22	36 ... 50	650	100	A	3RV11 42-4HA10		1	1 unit	41E
	63	30	45 ... 63	819	100	A	3RV11 42-4JA10		1	1 unit	41E
	75	37	57 ... 75	975	100	A	3RV11 42-4KA10		1	1 unit	41E
	90	45	70 ... 90	1 170	100	A	3RV11 42-4LA10		1	1 unit	41E
	100	45	80 ... 100	1 235	100	A	3RV11 42-4MA10		1	1 unit	41E

¹⁾ Guide value for 4-pole standard motors at 50 Hz 400 V AC. The actual starting and rated data of the motor to be protected must be considered when selecting the units.

²⁾ Accessories for mounting on the right (for sizes S0 to S3) and 3RV19 15 three-phase busbars (for size S0) cannot be used.

Auxiliary switches and other accessories can be ordered separately (see "Mountable Accessories" on page 7/18 onwards).

Motor Starter Protectors

SIRIUS 3RV1 motor starter protectors up to 100 A

For starter combinations

Selection and ordering data

Without auxiliary switches

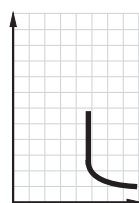

Rated current I_n	Suitable for three-phase induction motors ¹⁾ with P	Thermal overload release ²⁾	Instantaneous over-current release	Short-circuit breaking capacity at 400 V AC I_{cu}	DT	Screw terminals	PU (UNIT, SET, M)	PS*	PG	
										Order No.
A	kW	A	A	kA						
Size S0										
	0,16	0,04	None	2,1	100	A	3RV13 21-0AC10	1	1 unit	41E
	0,2	0,06	None	2,6	100	A	3RV13 21-0BC10	1	1 unit	41E
	0,25	0,06	None	3,3	100	A	3RV13 21-0CC10	1	1 unit	41E
	0,32	0,09	None	4,2	100	A	3RV13 21-0DC10	1	1 unit	41E
	0,4	0,09	None	5,2	100	A	3RV13 21-0EC10	1	1 unit	41E
	0,5	0,12	None	6,5	100	A	3RV13 21-0FC10	1	1 unit	41E
	0,63	0,18	None	8,2	100	A	3RV13 21-0GC10	1	1 unit	41E
	0,8	0,18	None	10	100	A	3RV13 21-0HC10	1	1 unit	41E
	1	0,25	None	13	100	A	3RV13 21-0JC10	1	1 unit	41E
	1,25	0,37	None	16	100	A	3RV13 21-0KC10	1	1 unit	41E
	1,6	0,55	None	21	100	A	3RV13 21-1AC10	1	1 unit	41E
	2	0,75	None	26	100	A	3RV13 21-1BC10	1	1 unit	41E
	2,5	0,75	None	33	100	A	3RV13 21-1CC10	1	1 unit	41E
	3,2	1,1	None	42	100	A	3RV13 21-1DC10	1	1 unit	41E
	4	1,5	None	52	100	A	3RV13 21-1EC10	1	1 unit	41E
	5	1,5	None	65	100	A	3RV13 21-1FC10	1	1 unit	41E
6,3	2,2	None	82	100	A	3RV13 21-1GC10	1	1 unit	41E	
8	3	None	104	100	A	3RV13 21-1HC10	1	1 unit	41E	
10	4	None	130	100	A	3RV13 21-1JC10	1	1 unit	41E	
12,5	5,5	None	163	100	A	3RV13 21-1KC10	1	1 unit	41E	
16	7,5	None	208	50	A	3RV13 21-4AC10	1	1 unit	41E	
20	7,5	None	260	50	A	3RV13 21-4BC10	1	1 unit	41E	
22	11	None	286	50	A	3RV13 21-4CC10	1	1 unit	41E	
25	11	None	325	50	A	3RV13 21-4DC10	1	1 unit	41E	

Size S2

	16	7,5	None	208	50	A	3RV13 31-4AC10	1	1 unit	41E
	20	7,5	None	260	50	A	3RV13 31-4BC10	1	1 unit	41E
	25	11	None	325	50	A	3RV13 31-4DC10	1	1 unit	41E
	32	15	None	416	50	A	3RV13 31-4EC10	1	1 unit	41E
	40	18,5	None	520	50	A	3RV13 31-4FC10	1	1 unit	41E
	45	22	None	585	50	A	3RV13 31-4GC10	1	1 unit	41E
	50	22	None	650	50	A	3RV13 31-4HC10	1	1 unit	41E

3RV13 31-4AC10

Size S3

	40	18,5	None	520	50	A	3RV13 41-4FC10	1	1 unit	41E
	50	22	None	650	50	A	3RV13 41-4HC10	1	1 unit	41E
	63	30	None	819	50	A	3RV13 41-4JC10	1	1 unit	41E
	75	37	None	975	50	A	3RV13 41-4KC10	1	1 unit	41E
	90	45	None	1 170	50	A	3RV13 41-4LC10	1	1 unit	41E
	100	45	None	1 235	50	A	3RV13 41-4MC10	1	1 unit	41E

3RV13 41-4JC10

Size S3, with increased switching capacity

	16	7,5	None	208	100	A	3RV13 42-4AC10	1	1 unit	41E
	20	7,5	None	260	100	A	3RV13 42-4BC10	1	1 unit	41E
	25	11	None	325	100	A	3RV13 42-4DC10	1	1 unit	41E
	32	15	None	416	100	A	3RV13 42-4EC10	1	1 unit	41E
	40	18,5	None	520	100	A	3RV13 42-4FC10	1	1 unit	41E
	50	22	None	650	100	A	3RV13 42-4HC10	1	1 unit	41E
	63	30	None	819	100	A	3RV13 42-4JC10	1	1 unit	41E
	75	37	None	975	100	A	3RV13 42-4KC10	1	1 unit	41E
	90	45	None	1 170	100	A	3RV13 42-4LC10	1	1 unit	41E
	100	45	None	1 235	100	A	3RV13 42-4MC10	1	1 unit	41E

3RV13 42-4JC10

¹⁾ Guide value for 4-pole standard motors at 50 Hz 400 V AC. The actual starting and rated data of the motor to be protected must be considered when selecting the units.

²⁾ For overload protection of the motors, appropriate overload relays must be used.

Auxiliary switches and other accessories can be ordered separately (see "Mountable Accessories" on page 7/18 onwards).

Multi-unit and reusable packagings

- Size S0 on request
- Sizes S2 and S3 see Catalog IC 10 · 2012

Motor Starter Protectors

SIRIUS 3RV1 motor starter protectors up to 100 A



For transformer protection

Selection and ordering data

CLASS 10, without auxiliary switches

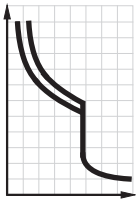
Motor starter protectors for the protection of transformers with high inrush current



Rated current	Setting range for thermal overload release	Instantaneous overcurrent release	Short-circuit breaking capacity at 400 V AC	DT	Screw terminals	PU (UNIT, SET, M)	PS*	PG	
I_n		$I >$	I_{cu}		Order No.	Price € per PU			
A	A	A	kA						
Size S0									
 3RV14 21-0KA10	0,16	0,11 ... 0,16	3,3	100	▶	3RV14 21-0AA10	1	1 unit	41E
	0,2	0,14 ... 0,2	4,2	100	▶	3RV14 21-0BA10	1	1 unit	41E
	0,25	0,18 ... 0,25	5,2	100	▶	3RV14 21-0CA10	1	1 unit	41E
	0,32	0,22 ... 0,32	6,5	100	▶	3RV14 21-0DA10	1	1 unit	41E
	0,4	0,28 ... 0,4	8,2	100	▶	3RV14 21-0EA10	1	1 unit	41E
	0,5	0,35 ... 0,5	10	100	▶	3RV14 21-0FA10	1	1 unit	41E
	0,63	0,45 ... 0,63	13	100	▶	3RV14 21-0GA10	1	1 unit	41E
	0,8	0,55 ... 0,8	16	100	▶	3RV14 21-0HA10	1	1 unit	41E
	1	0,7 ... 1	21	100	▶	3RV14 21-0JA10	1	1 unit	41E
	1,25	0,9 ... 1,25	26	100	▶	3RV14 21-0KA10	1	1 unit	41E
	1,6	1,1 ... 1,6	33	100	▶	3RV14 21-1AA10	1	1 unit	41E
	2	1,4 ... 2	42	100	▶	3RV14 21-1BA10	1	1 unit	41E
	2,5	1,8 ... 2,5	52	100	▶	3RV14 21-1CA10	1	1 unit	41E
	3,2	2,2 ... 3,2	65	100	▶	3RV14 21-1DA10	1	1 unit	41E
	4	2,8 ... 4	82	100	▶	3RV14 21-1EA10	1	1 unit	41E
	5	3,5 ... 5	104	100	▶	3RV14 21-1FA10	1	1 unit	41E
	6,3	4,5 ... 6,3	130	100	▶	3RV14 21-1GA10	1	1 unit	41E
	8	5,5 ... 8	163	100	▶	3RV14 21-1HA10	1	1 unit	41E
	10	7 ... 10	208	100	▶	3RV14 21-1JA10	1	1 unit	41E
12,5	9 ... 12,5	260	100	▶	3RV14 21-1KA10	1	1 unit	41E	
16	11 ... 16	286	50	▶	3RV14 21-4AA10	1	1 unit	41E	
20	14 ... 20	325	50	▶	3RV14 21-4BA10	1	1 unit	41E	
Size S2									
 3RV14 31-4DA10	16	11 ... 16	325	50	▶	3RV14 31-4AA10	1	1 unit	41E
	20	14 ... 20	416	50	▶	3RV14 31-4BA10	1	1 unit	41E
	25	18 ... 25	520	50	▶	3RV14 31-4DA10	1	1 unit	41E
	32	22 ... 32	660	50	▶	3RV14 31-4EA10	1	1 unit	41E
	40	28 ... 40	836	50	▶	3RV14 31-4FA10	1	1 unit	41E

Auxiliary switches and other accessories can be ordered separately (see "Mountable Accessories" on page 7/18 onwards).

Multi-unit and reusable packagings

- Size S0 on request
- Size S2 see Catalog IC 10 · 2012





Motor Starter Protectors

SIRIUS 3RV1 motor starter protectors up to 100 A

For fuse monitoring

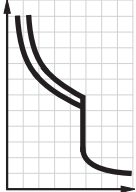
Selection and ordering data

Without auxiliary switches

	Rated current	Thermal over-load release	Instantaneous overcurrent release	Short-circuit breaking capacity at 400 V AC	DT	Screw terminals 	PU (UNIT, SET, M)	PS*	PG
	I_n			I_{cu}		Order No.	Price € per PU		
	A	A	A	kA					

Size S00



3RV16 11-0BD10

0,2	0,2	1,2	100	▶	3RV16 11-0BD10	1	1 unit	41E
-----	-----	-----	-----	---	-----------------------	---	--------	-----

Note:

The auxiliary switch required for signaling must be ordered separately.

Multi-unit packing and reusable packaging on request.

Accessories

Version	Contacts	DT	Screw terminals 	PU (UNIT, SET, M)	PS*	PG
			Order No.	Price € per PU		

Mountable auxiliary switches (essential accessories)



3RV19 01-1E

Transverse auxiliary switches With screw terminals, mountable on front	1 NO + 1 NC	▶	3RV19 01-1E	1	1 unit	41E
--	-------------	---	--------------------	---	--------	-----



3RV19 01-1A

Lateral auxiliary switches With screw terminals, mountable on the left	1 NO + 1 NC	▶	3RV19 01-1A	1	1 unit	41E
--	-------------	---	--------------------	---	--------	-----

Additional auxiliary switches and other accessories see "Mountable Accessories" on page 7/18 onwards.

Motor Starter Protectors





SIRIUS 3RV1 circuit breakers up to 100 A

For system protection
according to UL 489/CSA C22.2 No. 5-02

Selection and ordering data

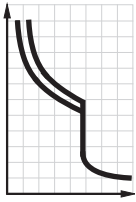
Without auxiliary switches

Circuit breakers for system protection and non-motor loads according to UL/CSA

	Rated current ¹⁾	Thermal over-load release (non-adjustable)	Instantaneous over-current release	Short-circuit breaking capacity at 480 Y/277 V AC ²⁾ 480 V AC		DT	Screw terminals 	PU (UNIT, SET, M)	PS*	PG
	I_n ¹⁾		$I >$	I_{bc}	I_{bc}		Order No.	Price € per PU		
	A	A	A	kA	kA					
Size S0										
	0,16	0,16	2,1	50	--	C	3RV17 21-0AD10	1	1 unit	41E
	0,2	0,2	2,6	50	--	C	3RV17 21-0BD10	1	1 unit	41E
	0,25	0,25	3,3	50	--	C	3RV17 21-0CD10	1	1 unit	41E
	0,32	0,32	4,2	50	--	C	3RV17 21-0DD10	1	1 unit	41E
	0,4	0,4	5,2	50	--	C	3RV17 21-0ED10	1	1 unit	41E
	0,5	0,5	6,5	50	--	C	3RV17 21-0FD10	1	1 unit	41E
	0,63	0,63	8,2	50	--	C	3RV17 21-0GD10	1	1 unit	41E
	0,8	0,8	10	50	--	C	3RV17 21-0HD10	1	1 unit	41E
	1	1	13	50	--	C	3RV17 21-0JD10	1	1 unit	41E
	1,25	1,25	16	50	--	C	3RV17 21-0KD10	1	1 unit	41E
	1,6	1,6	21	50	--	C	3RV17 21-1AD10	1	1 unit	41E
	2	2	26	50	--	C	3RV17 21-1BD10	1	1 unit	41E
	2,5	2,5	33	50	--	C	3RV17 21-1CD10	1	1 unit	41E
	3,2	3,2	42	50	--	C	3RV17 21-1DD10	1	1 unit	41E
	4	4	52	50	--	C	3RV17 21-1ED10	1	1 unit	41E
	5	5	65	50	--	C	3RV17 21-1FD10	1	1 unit	41E
	6,3	6,3	82	50	--	C	3RV17 21-1GD10	1	1 unit	41E
8	8	104	50	--	C	3RV17 21-1HD10	1	1 unit	41E	
10	10	130	50	--	C	3RV17 21-1JD10	1	1 unit	41E	
12,5	12,5	163	50	--	C	3RV17 21-1KD10	1	1 unit	41E	
15	15	208	50	--	C	3RV17 21-4AD10	1	1 unit	41E	
20	20	260	50	--	C	3RV17 21-4BD10	1	1 unit	41E	
22	22	286	50	--	C	3RV17 21-4CD10	1	1 unit	41E	
Size S3										
	10	10	150	65	65	B	3RV17 42-5AD10	1	1 unit	41E
	15	15	225	65	65	B	3RV17 42-5BD10	1	1 unit	41E
	20	20	260	65	65	B	3RV17 42-5CD10	1	1 unit	41E
	25	25	325	65	65	B	3RV17 42-5DD10	1	1 unit	41E
	30	30	390	65	65	B	3RV17 42-5ED10	1	1 unit	41E
	35	35	455	65	--	B	3RV17 42-5FD10	1	1 unit	41E
	40	40	520	65	--	B	3RV17 42-5GD10	1	1 unit	41E
	45	45	585	65	--	B	3RV17 42-5HD10	1	1 unit	41E
	50	50	650	65	--	B	3RV17 42-5JD10	1	1 unit	41E
	60	60	780	65	--	B	3RV17 42-5LD10	1	1 unit	41E
	70	70	910	65	--	B	3RV17 42-5QD10	1	1 unit	41E

¹⁾ Rated value 100 % according to UL 489 and IEC 60947-2 ("100 % rated breaker").

²⁾ Values for 600 Y/347 V AC see "Technical Specifications" → "Permissible rated data of devices approved for North America (UL/CSA)" → "3RV17 Motor Starter Protectors as Circuit Breakers" in "Reference Manual for Protection Equipment – Motor Starter Protectors · 3RV1 Molded Case Motor Starter Protectors".

Transverse auxiliary switches must not be mounted, lateral auxiliary switches can be ordered separately (see "Mountable Accessories" on page 7/18 onwards).

Motor Starter Protectors

SIRIUS 3RV1 circuit breakers up to 100 A



For transformer protection
according to UL 489/CSA C22.2 No. 5-02

Selection and ordering data

Without auxiliary switches

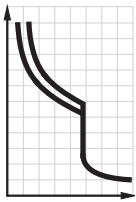
Circuit breakers for system and transformer protection according to UL/CSA, specially designed for transformers with high inrush current



Rated current ¹⁾	Thermal overload release (non-adjustable)	Instantaneous over-current release	Short-circuit breaking capacity at 480 Y/277 V AC ²⁾	DT	Screw terminals	PU (UNIT, SET, M)	PS*	PG
I_n ¹⁾			I_{bc}		Order No.	Price € per PU		
A	A	A	kA					
Size S0								
	0,16	0,16	3,3	50	C	3RV18 21-0AD10	1	1 unit 41E
	0,2	0,2	4,2	50	C	3RV18 21-0BD10	1	1 unit 41E
	0,25	0,25	5,2	50	C	3RV18 21-0CD10	1	1 unit 41E
	0,32	0,32	6,5	50	C	3RV18 21-0DD10	1	1 unit 41E
	0,4	0,4	8,2	50	C	3RV18 21-0ED10	1	1 unit 41E
	0,5	0,5	10	50	C	3RV18 21-0FD10	1	1 unit 41E
	0,63	0,63	13	50	C	3RV18 21-0GD10	1	1 unit 41E
	0,8	0,8	16	50	C	3RV18 21-0HD10	1	1 unit 41E
	1	1	21	50	C	3RV18 21-0JD10	1	1 unit 41E
	1,25	1,25	26	50	C	3RV18 21-0KD10	1	1 unit 41E
	1,6	1,6	33	50	C	3RV18 21-1AD10	1	1 unit 41E
	2	2	42	50	C	3RV18 21-1BD10	1	1 unit 41E
	2,5	2,5	52	50	C	3RV18 21-1CD10	1	1 unit 41E
	3,2	3,2	65	50	C	3RV18 21-1DD10	1	1 unit 41E
	4	4	82	50	C	3RV18 21-1ED10	1	1 unit 41E
	5	5	104	50	C	3RV18 21-1FD10	1	1 unit 41E
	6,3	6,3	130	50	C	3RV18 21-1GD10	1	1 unit 41E
	8	8	163	50	C	3RV18 21-1HD10	1	1 unit 41E
	10	10	208	50	C	3RV18 21-1JD10	1	1 unit 41E
	12,5	12,5	260	50	C	3RV18 21-1KD10	1	1 unit 41E
	15	15	286	50	C	3RV18 21-4AD10	1	1 unit 41E
	20	20	325	50	C	3RV18 21-4BD10	1	1 unit 41E

¹⁾ Rated value 100 % according to UL 489 and IEC 60947-2 (*100 % rated breaker*).



²⁾ Values for 600 Y/347 V AC see "Technical Specifications" → "Permissible rated data of devices approved for North America (UL/CSA)" → "3RV18 Motor Starter Protectors as Circuit Breakers" in "Reference Manual for Protection Equipment – Motor Starter Protectors · 3RV1 Molded Case Motor Starter Protectors".

Transverse auxiliary switches must not be mounted, lateral auxiliary switches can be ordered separately (see "Mountable Accessories" on page 7/18 onwards).

Motor Starter Protectors

SIRIUS 3RV1 motor starter protectors up to 100 A

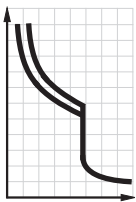
For distance protection
Selection and ordering data
Voltage transformer circuit breakers with auxiliary switches (1 CO)

	Rated current	Thermal overload release	Instantaneous over-current release	Auxiliary switch integrated in the motor starter protector, transverse	Short-circuit breaking capacity at 400 V AC	DT	Screw terminals	PU (UNIT, SET, M)	PS*	PG	
	I_n				I_{cu}		Order No.	Price € per PU			
Size S00											
	1,4	1,4	6	1 CO	50	B	3RV16 11-1AG14 3RV16 11-1CG14 3RV16 11-1DG14	1	1 unit	41E	
	2,5	2,5	10,5	1 CO	50	▶			1	1 unit	41E
	3	3	20	1 CO	50	▶			1	1 unit	41E



3RV16 11-1.G14

Accessories

Version	Contacts	DT	Screw terminals	PU (UNIT, SET, M)	PS*	PG
			Order No.	Price € per PU		
Mountable auxiliary switches for other signaling purposes						
	Lateral auxiliary switches		▶	3RV19 01-1A	1	1 unit 41E
	With screw terminals, mountable on the left					

3RV19 01-1A

Additional auxiliary switches and other accessories see "Mountable Accessories" on page 7/18 onwards.

More information
Conversion of 3VU13 to 3RV1 voltage transformer circuit breakers

The 3VU13 voltage transformer circuit breakers previously available have been discontinued. The 3RV1 voltage transformer circuit breakers are offered as replacement types.

Previous type	Replacement type
3VU13 11-6HR00	3RV16 11-1CG14
3VU13 21-6HR00	3RV16 11-1CG14 + 3RV19 01-1A
3VU13 11-6JR00	3RV16 11-1DG14

Motor Starter Protectors

SIRIUS 3RV1 motor starter protectors up to 100 A

Accessories

Mountable accessories

Overview

Mounting location and function

The 3RV1 motor starter protectors have three main contact elements. In order to achieve maximum flexibility, auxiliary switches, signaling switches, auxiliary releases and isolator modules can be supplied separately.

These components are easily fitted to the switches without the use of any tools according to requirements.

Overview graphic [see page 7/5 onwards](#).

Front panel Notes: <ul style="list-style-type: none"> A maximum of 4 auxiliary contacts with auxiliary switches can be attached to each motor starter protector. Transverse auxiliary switches must not be used for the 3RV17 and 3RV18 circuit breakers. 	Transverse auxiliary switches, solid-state compatible transverse auxiliary switches 1 NO + 1 NC or 2 NO or 1 CO	An auxiliary switch block can be inserted transversely on the front. The overall width of the motor starter protectors remains unchanged.
Left-hand side Notes: <ul style="list-style-type: none"> A maximum of 4 auxiliary contacts with auxiliary switches can be attached to each motor starter protector. Auxiliary switches (2 contacts) and signaling switches can be mounted separately or together. The signaling switch cannot be used for the 3RV17 and 3RV18 circuit breakers. 	Lateral auxiliary switches (2 contacts) 1 NO + 1 NC or 2 NO or 2 NC	One of the three lateral auxiliary switches can be mounted on the left side per motor starter protector. The contacts of the auxiliary switch close and open together with the main contacts of the motor starter protector. The width of the lateral auxiliary switch with 2 contacts is 9 mm.
	Lateral auxiliary switches (4 contacts) 2 NO + 2 NC	One lateral auxiliary switch with four contacts can be mounted on the left side per motor starter protector. The contacts of the auxiliary switch close and open together with the main contacts of the motor starter protector. The width of the lateral auxiliary switch with 4 contacts is 18 mm.
	Signaling switches for sizes S0, S2, and S3 Tripping 1 NO + 1 NC Short circuit 1 NO + 1 NC	One signaling switch can be mounted on the left side of each motor starter protector. The signaling switch has two contact systems. One contact system always signals <u>tripping</u> irrespective of whether this was caused by a short circuit, an overload or an auxiliary release. The other contact system only switches in the event of a short circuit. There is no signaling as a result of <u>switching off</u> with the handle. In order to be able to switch on the motor starter protector again after a short circuit, the signaling switch must be reset manually after the error cause has been eliminated. The overall width of the signaling switch is 18 mm.
Right-hand side Notes: <ul style="list-style-type: none"> One auxiliary release can be mounted per motor starter protector. Accessories cannot be mounted at the right-hand side of the 3RV11 motor starter protectors for motor protection with overload relay function. 	Auxiliary releases Shunt releases or Undervoltage releases or Undervoltage releases with leading auxiliary contacts 2 NO	For remote-controlled tripping of the motor starter protector. The release coil should only be energized for short periods (see circuit diagrams). Trips the motor starter protector when the voltage is interrupted and prevents the motor from being restarted accidentally when the voltage is restored. Used for remote-controlled tripping of the motor starter protector. Particularly suitable for EMERGENCY-STOP disconnection by way of the corresponding EMERGENCY-STOP pushbutton according to IEC 60204-1. Function and use as for the undervoltage release without leading auxiliary contacts, but with the following additional function: the auxiliary contacts will open in switch position OFF to deenergize the coil of the undervoltage release, thus interrupting energy consumption. In the "tripped" position, these auxiliary contacts are not guaranteed to open. The leading contacts permit the motor starter protector to reclose. The overall width of the auxiliary release is 18 mm.
Top Notes: <ul style="list-style-type: none"> The isolator module cannot be used for the 3RV17 and 3RV18 circuit breakers. The isolator module covers the terminal screws of the transverse auxiliary switch. If the isolator module is used, we therefore recommend that either the lateral auxiliary switches be fitted or that the isolator module not be mounted until the auxiliary switch has been wired. 	Isolator modules for sizes S0 and S2	Isolator modules can be mounted to the upper terminal end of motor starter protector of sizes S0 and S2. The supply cable is connected to the motor starter protector through the isolator module. The plug can only be unplugged when the motor starter protector is open and isolates all 3 poles of the motor starter protector from the network. The shock-protected isolation point is clearly visible and secured with a padlock to prevent reinsertion of the plug.





For a complete overview of which accessories can be used for the various motor starter protectors, [see page 7/2](#).

Motor Starter Protectors



SIRIUS 3RV1 motor starter protectors up to 100 A

Accessories
Mountable accessories

Selection and ordering data

Version	Contacts	For motor starter protectors	DT	Screw terminals	PU (UNIT, SET, M)	PS*	PG
Size				Order No.	Price € per PU		
Auxiliary switches¹⁾							
 3RV19 01-1E	Transverse auxiliary switches with screw terminals, mountable on front	1 CO 1 NO + 1 NC 2 NO	S00, S0, S2, S3	▶ ▶ ▶	3RV19 01-1D 3RV19 01-1E 3RV19 01-1F	1 1 1	1 unit 1 unit 1 unit 41E
 3RV19 01-1G	Solid-state compatible transverse auxiliary switches with screw terminals, front mountable, for operation in dusty atmosphere and in solid-state circuits with low operating currents	1 CO	S00, S0, S2, S3	A	3RV19 01-1G	1	1 unit 41E
 3RV19 01-0H	Covers for transverse auxiliary switches	--	S00, S0, S2, S3	▶	3RV19 01-0H	1	10 units 41E
 3RV19 01-1A	Lateral auxiliary switches With screw terminals, mountable on the left	1 NO + 1 NC 2 NO 2 NC 2 NO + 2 NC	S00, S0, S2, S3	▶ ▶ ▶ A	3RV19 01-1A 3RV19 01-1B 3RV19 01-1C 3RV19 01-1J	1 1 1 1	1 unit 1 unit 1 unit 1 unit 41E 41E 41E 41E
 3RV19 01-1J							

¹⁾ Each motor starter protector can be fitted with one transverse and one lateral auxiliary switch. The lateral auxiliary switch with 2 NO + 2 NC is used without a transverse auxiliary switch. Transverse auxiliary switches must not be used for the 3RV17 and 3RV18 circuit breakers.

Version	Contacts	For motor starter protectors	DT	Spring-type terminals	PU (UNIT, SET, M)	PS*	PG
Size				Order No.	Price € per PU		
Auxiliary switches¹⁾							
 3RV19 01-2E	Transverse auxiliary switches With spring-type terminals, mountable on the front	1 NO + 1 NC 2 NO	S00, S0, S2, S3	▶ ▶	3RV19 01-2E 3RV19 01-2F	1 1	1 unit 1 unit 41E 41E
 3RV19 01-2A	Lateral auxiliary switches With spring-type terminals, mountable on the left	1 NO + 1 NC 2 NO 2 NC	S00, S0, S2, S3	▶ ▶ ▶	3RV19 01-2A 3RV19 01-2B 3RV19 01-2C	1 1 1	1 unit 1 unit 1 unit 41E 41E 41E



¹⁾ Each motor starter protector can be fitted with one transverse and one lateral auxiliary switch. Transverse auxiliary switches must not be used for the 3RV17 and 3RV18 circuit breakers.

Motor Starter Protectors

SIRIUS 3RV1 motor starter protectors up to 100 A

Accessories

Mountable accessories

Version	For motor starter protectors	DT	Screw terminals	⊕	PU (UNIT, SET, M)	PS*	PG
Size		Order No.	Price € per PU				
Signaling switches¹⁾							
	Signaling switches Separate tripped and short-circuit alarms, 1 NO + 1 NC each One signaling switch can be mounted on the left of the motor starter protector.	S0, S2, S3	▶	3RV19 21-1M	1	1 unit	41E
3RV19 21-1M							
Isolator modules¹⁾							
	Isolator modules Visible isolating distance for isolating individual motor starter protectors from the network, lockable in disconnected position	S0 S2	▶ ▶	3RV19 28-1A 3RV19 38-1A	1 1	1 unit 1 unit	41E 41E
3RV19 38-1A with padlock							

1) This accessory cannot be used for the 3RV17 and 3RV18 circuit breakers.

Rated control supply voltage U_s					For motor starter protectors	DT	Screw terminals	⊕	PU (UNIT, SET, M)	PS*	PG
AC 50 Hz	AC 60 Hz	AC 50/60 Hz	AC/DC 50/60 Hz, DC	DC	Size		Order No.	Price € per PU			
V	V	V	V	V							
Auxiliary releases³⁾											
Undervoltage releases											
--	--	--	--	24	S00, S0, S2, S3	A	3RV19 02-1AB4		1	1 unit	41E
24	--	--	--	--	S00, S0, S2, S3	A	3RV19 02-1AB0		1	1 unit	41E
110	120	--	--	--	S00, S0, S2, S3	A	3RV19 02-1AF0		1	1 unit	41E
--	208	--	--	--	S00, S0, S2, S3	A	3RV19 02-1AM1		1	1 unit	41E
230	240	--	--	--	S00, S0, S2, S3	▶	3RV19 02-1AP0		1	1 unit	41E
400	440	--	--	--	S00, S0, S2, S3	▶	3RV19 02-1AV0		1	1 unit	41E
415	480	--	--	--	S00, S0, S2, S3	A	3RV19 02-1AV1		1	1 unit	41E
500	600	--	--	--	S00, S0, S2, S3	A	3RV19 02-1AS0		1	1 unit	41E
Undervoltage releases with leading auxiliary contacts 2 NO											
230	240	--	--	--	S00	A	3RV19 12-1CP0		1	1 unit	41E
400	440	--	--	--	S00	A	3RV19 12-1CV0		1	1 unit	41E
415	480	--	--	--	S00	A	3RV19 12-1CV1		1	1 unit	41E
230	240	--	--	--	S0, S2, S3	A	3RV19 22-1CP0		1	1 unit	41E
400	440	--	--	--	S0, S2, S3	A	3RV19 22-1CV0		1	1 unit	41E
415	480	--	--	--	S0, S2, S3	A	3RV19 22-1CV1		1	1 unit	41E
Shunt releases											
--	--	20 ... 24	20 ... 70	--	S00, S0, S2, S3	▶	3RV19 02-1DB0		1	1 unit	41E
--	--	90 ... 110	70 ... 190	--	S00, S0, S2, S3	▶	3RV19 02-1DF0		1	1 unit	41E
--	--	210 ... 240	190 ... 330	--	S00, S0, S2, S3	▶	3RV19 02-1DP0		1	1 unit	41E
--	--	350 ... 415	330 ... 500	--	S00, S0, S2, S3	A	3RV19 02-1DV0		1	1 unit	41E
--	--	500	500	--	S00, S0, S2, S3	A	3RV19 02-1DS0		1	1 unit	41E

1) The voltage range is valid for 100 % (infinite) ON period. The response voltage lies at 0.9 of the lower limit of the voltage range.

2) The voltage range is valid for 5 s ON period at AC 50/60Hz and DC. The response voltage lies at 0.85 of the lower limit of the voltage range.

3) One auxiliary release can be mounted on the right per motor starter protector (does not apply to 3RV11 motor starter protectors with overload relay function).

Motor Starter Protectors

SIRIUS 3RV1 motor starter protectors up to 100 A

Accessories
Busbar accessories

Overview

Insulated three-phase busbar system

Three-phase busbar systems provide an easy, time-saving and clearly arranged means of feeding 3RV1 motor starter protectors with screw terminals. Different designs are available for sizes S00, S0 and S2 and can be used for the various different versions of motor starter protectors/circuit breakers. The 3RV19 15 three-phase busbar systems are not suitable for 3RV11 motor starter protectors with overload relay function. The three-phase bus bars must not be used for 3RV17 and 3RV18 circuit breakers.

The busbars are suitable for between 2 and 5 motor starter protectors/circuit breakers. However, any kind of extension is possible by clamping the tags of an additional busbar (rotated by 180°) underneath the terminals of the respective last motor starter protector.

A combination of motor starter protectors of different sizes is possible only with sizes S00 and S0. Connecting pieces are available for this purpose. The motor starter protectors are supplied by appropriate feeder terminals.

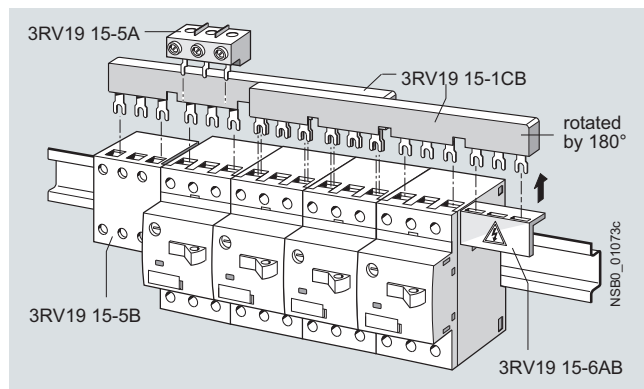

3-phase busbar system SIRIUS, size S00

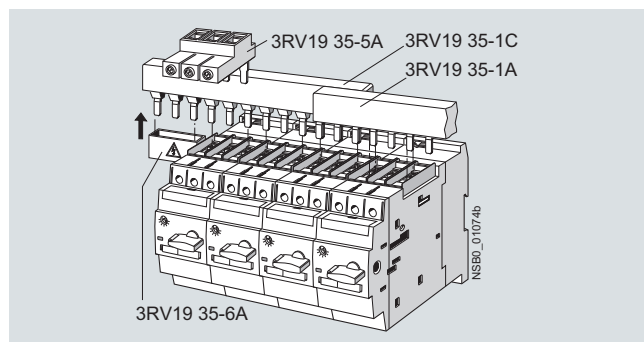

SIRIUS three-phase busbar system size S2

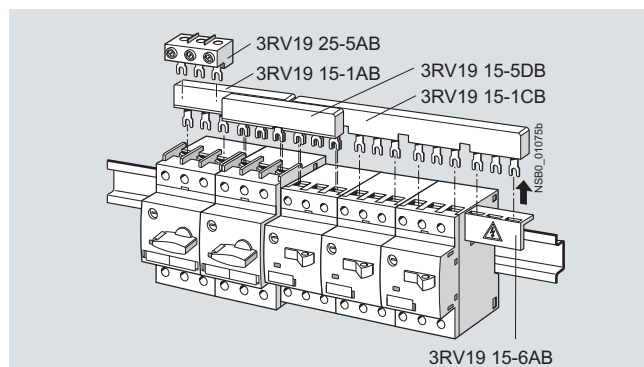

3-phase busbar system SIRIUS, with example for combining sizes S00 and S0

The three-phase busbar systems are finger-safe. They are designed for any short-circuit stress which can occur at the output side of connected motor starter protectors.

The three-phase busbar systems can also be used to construct "Type E Starters" of size S00 or S2 according to UL/CSA. Special feeder terminals must be used for this purpose however (see page 7/22).

Busbar adapters 8US for 40 mm and 60 mm systems

The motor starter protectors are mounted directly with the aid of busbar adapters on busbar systems with 40 mm and 60 mm center-to-center clearance in order to save space and to reduce infeed times and costs. Busbar adapters for busbar systems with 40 mm center-to-center spacing are suitable for copper busbars with a width of 12 mm to 15 mm, while those with 60 mm center-to-center spacing are suitable for copper busbars with a width of 12 mm to 30 mm. The busbars can be 4 to 5 mm or 10 mm thick.

The motor starter protectors/circuit breakers are snapped onto the adapter and connected on the line side. This prepared unit is then plugged directly onto the busbar system, and is thus connected both mechanically and electrically at the same time.

Further busbar adapters for snap-mounting direct-on-line starters and reversing starters as well as additional accessories such as line terminals and outgoing terminals, flat copper profile, etc. see Catalog LV 10.1.

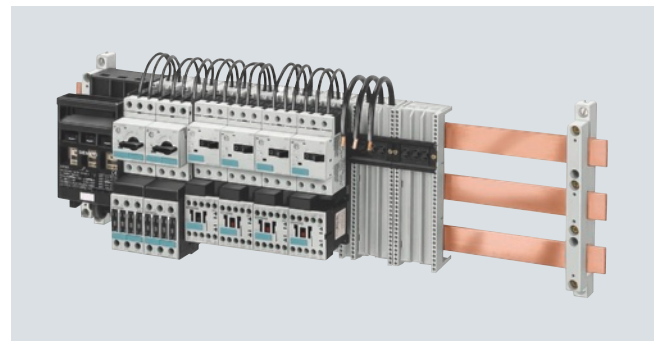

SIRIUS load feeders with busbar adapters snapped onto busbars





Motor Starter Protectors

SIRIUS 3RV1 motor starter protectors up to 100 A

Accessories

Busbar accessories

Selection and ordering data

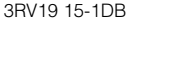
Modular spacing	Number of motor starter protectors that can be connected			Rated current I_n at 690 V	For motor starter protectors	DT	Order No.	Price € per PU	PU (UNIT, SET, M)	PS*	PG
	mm	Without lateral accessories	With lateral auxiliary switch								
Three-phase busbar systems											
 3RV19 15-1AB	For feeding several motor starter protectors with screw terminals, mounted side by side on standard mounting rails, insulated, with touch protection										
	45 ¹⁾²⁾	2	--	--	63	S00, S0	▶	3RV19 15-1AB	1	1 unit	41E
		3				S00, S0	▶	3RV19 15-1BB	1	1 unit	41E
		4				S00, S0	▶	3RV19 15-1CB	1	1 unit	41E
 3RV19 15-1BB	55 ¹⁾²⁾	--	2	--	63	S00, S0	▶	3RV19 15-2AB	1	1 unit	41E
			3			S00, S0	▶	3RV19 15-2BB	1	1 unit	41E
			4			S00, S0	▶	3RV19 15-2CB	1	1 unit	41E
 3RV19 15-1CB	63 ¹⁾²⁾	--	--	2	63	S00, S0	▶	3RV19 15-3AB	1	1 unit	41E
				4		S00, S0	▶	3RV19 15-3CB	1	1 unit	41E
 3RV19 15-1DB	55 ¹⁾	2	--	--	108	S2	▶	3RV19 35-1A	1	1 unit	41E
		3				S2	▶	3RV19 35-1B	1	1 unit	41E
		4				S2	▶	3RV19 35-1C	1	1 unit	41E
 3RV19 15-1DB	75 ³⁾	--	2	2	108	S2	▶	3RV19 35-3A	1	1 unit	41E
			3	3		S2	▶	3RV19 35-3B	1	1 unit	41E
			4	4		S2	▶	3RV19 35-3C	1	1 unit	41E
						S2	▶	3RV19 35-3C	1	1 unit	41E

1) Not suitable for 3RV11 motor starter protectors for motor protection with overload relay function. Common clamping of S00 and S0 motor starter protectors is not possible, due to the different modular spacings and terminal heights. A 3RV19 15-DB connector is available for connecting busbars from size S0 to size S00.

2) Not suitable for 3RV17 and 3RV18 circuit breakers according to UL 489 / CSA C22.2 No.5-02.

3) For 3RV1 motor starter protectors with accessories mounted on the side. Auxiliary releases and lateral auxiliary/signaling switches cannot be used in combination.



Version	Modular spacing	For motor starter protectors	DT	Order No.	Price € per PU	PU (UNIT, SET, M)	PS*	PG
	mm		Size					

Connecting pieces for three-phase busbars

 3RV19 15-5DB	For connecting three-phase busbars for motor starter protectors of size S0 (left) to size S00 (right)										
	45				45	S00, S0	▶	3RV19 15-5DB	1	1 unit	41E

Conductor cross-section			Tightening torques	For motor starter protectors	DT	Order No.	Price € per PU	PU (UNIT, SET, M)	PS*	PG
Solid or stranded	Finely stranded with end sleeve	AWG cables, solid or stranded								
mm ²	mm ²	AWG	Nm	Size						

Three-phase feeder terminals

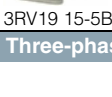
 3RV19 25-5AB	Connection from top										
	2,5 ... 25	4 ... 16	10 ... 4	4	S00	▶	3RV19 15-5A	1	1 unit	41E	
 3RV19 15-5B	Connection from below¹⁾										
	2,5 ... 25	4 ... 16	10 ... 4	Input: 4, Output: 2 ... 2,5	S00, S0	▶	3RV19 15-5B	1	1 unit	41E	
 3RV19 15-5B	Connection from top										
	2,5 ... 50	1,5 ... 35	14 ... 0	4	S2	▶	3RV19 35-5A	1	1 unit	41E	

Three-phase feeder terminals for constructing "Type E Starters"

Connection from top										
2,5 ... 25	4 ... 16	10-4	2 ... 4	S0	▶	3RV19 25-5EB	1	1 unit	41E	
10 ... 50	--	8 ... 0	4,5 ... 6	S2	▶	3RV19 35-5E	1	1 unit	41E	

1) This terminal is connected in place of a switch, please take the space requirement into account.

Motor Starter Protectors

SIRIUS 3RV1 motor starter protectors up to 100 A

Accessories
Busbar accessories

Version	For motor starter protectors	DT	Order No.	Price € per PU	PU (UNIT, SET, M)	PS*	PG
---------	------------------------------	----	-----------	----------------	-------------------	-----	----

Covers for connection tags



3RV19 15-6AB

Touch protection for empty positions

Size

S00, S0

**3RV19 15-6AB**

1 10 units

41E

S2

**3RV19 35-6A**

1 5 units

41E

8US busbar adapters



8US10 61-5FK08



8US11 11-4SM00



8US12 61-5FM08



8US12 11-4TR00

For motor starter protectors	Rated current	Connecting cable	Adapter length	Adapter width	Rated voltage	DT	Order No.	Price € per PU	PU (UNIT, SET, M)	PS*	PG
------------------------------	---------------	------------------	----------------	---------------	---------------	----	-----------	----------------	-------------------	-----	----

Size

A

AWG

mm

mm

V

Busbar adapters for 40 mm systems

For flat copper profiles according to DIN 46433

Width: 12 mm and 15 mm

Thickness: 5 mm and 10 mm

S00, S0	25	12	121	45	690	▶	8US10 51-5DJ07		1	1 unit	143
S00, S0 + lateral auxiliary switch	25	12	121	55	690	▶	8US10 61-5DJ07		1	1 unit	143
S2	56	8	139	55	690	▶	8US10 61-5FK08		1	1 unit	143
S3	100	4	182	70	400 ¹⁾	▶	8US11 11-4SM00		1	1 unit	143
S3	100	4	182	72	415 ... 690 ²⁾	▶	8US10 11-4TM00		1	1 unit	143

Busbar adapters for 60 mm systems

For flat copper profiles according to DIN 46433

Width: 12 mm and 30 mm

Thickness: 5 mm and 10 mm

also for T and double-T special profiles

S00, S0	25	12	182	45	690	▶	8US12 51-5DM07		1	1 unit	143
S2	56	8	182	55	690	▶	8US12 61-5FM08		1	1 unit	143
S3	100	4	182	70	400 ¹⁾	▶	8US11 11-4SM00		1	1 unit	143
S3	100	4	182	72	415 ... 690 ²⁾	A	8US12 11-4TM00		1	1 unit	143
S3 ³⁾	70 ⁴⁾	4	215	72	600 ⁴⁾	A	8US12 11-4TR00		1	1 unit	143

1) At rated voltage

≤ 400 V: short-circuit breaking capacity 50 kA,
> 400 to 460 V: short-circuit breaking capacity 25 kA.

2) Short-circuit breaking capacity 415/500/525 V AC

- up to $I_n = 25$ A: max. 30 kA- up to $I_n = 90$ A: max. 16 kA- up to $I_n = 100$ A: max. 6 kA

Short-circuit breaking capacity 690 V AC:

- max. 12 kA.

3) This busbar adapter is approved specially for 3RV17 42 circuit breakers for applications according to UL/CSA.

4) Values according to UL/CSA

- Rated current: 70 A at 600 V AC;

- Short-circuit breaking capacity:

480 V AC: 65 kA, up to $I_n = 30$ A;

480 Y/277 V AC: 65 kA;

600 Y/347 V AC: 20 kA.

Additional busbar adapters see Catalog LV 10.1.

Motor Starter Protectors

SIRIUS 3RV1 motor starter protectors up to 100 A

Accessories

Rotary operating mechanisms

Overview

Door-coupling rotary operating mechanisms

Motor starter protectors with a rotary operating mechanism can be mounted in a control cabinet and operated externally by means of a door-coupling rotary operating mechanism. When the cabinet door with motor starter protector is closed, the operating mechanism is coupled. When the motor starter protector closes, the coupling is locked which prevents the door from being opened unintentionally. This interlock can be defeated by the maintenance personnel. In the OPEN position, the rotary operating mechanism can be secured against reclosing with up to three padlocks. Inadvertent opening of the door is not possible in this case either.

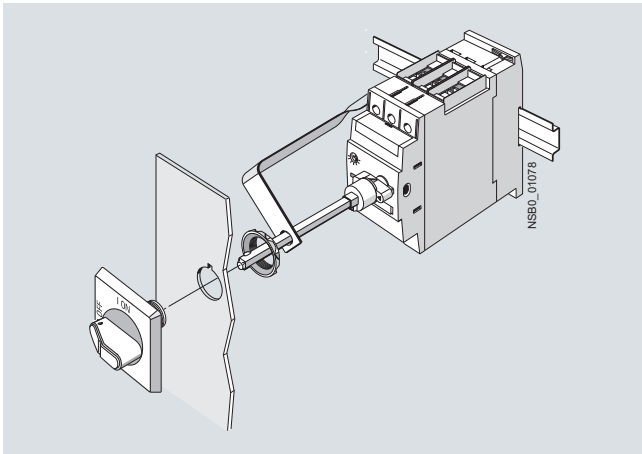

SIRIUS 3RV19 26-0K door-coupling rotary operating mechanism

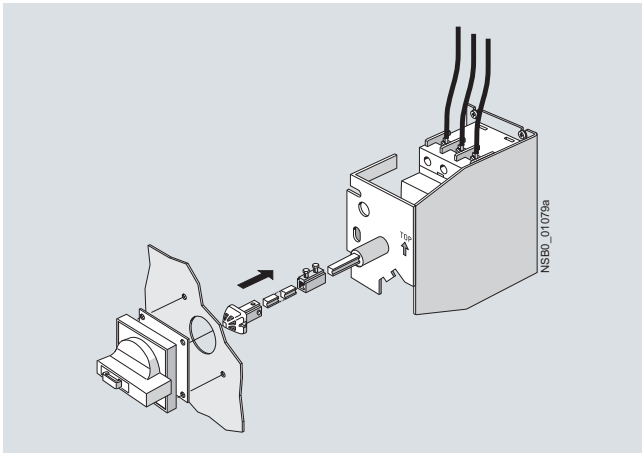

SIRIUS 3RV29 36-2B door-coupling rotary operating mechanism for arduous conditions

Remote motorized operating mechanisms

3RV1 motor starter protectors are manually operated controls. They automatically trip in case of an overload or short circuit. Intentional remote-controlled tripping is possible by means of a shunt release or an undervoltage release. Reclosing is only possible directly at the motor starter protector.

The remote motorized operating mechanism allows the motor starter protectors to be opened and closed by electrical commands. This enables a load or an installation to be isolated from the network or reconnected to it from an operator panel.

If the motor starter protector is tripped as a result of overload or short circuit, it will be in tripped position. For reclosing, the remote motorized operating mechanism must first be set manually or electrically to the 0 position (electrically by means of the Open command). Then it can be reclosed.

The remote motorized operating mechanism is available for motor starter protectors of size S2 ($I_{n\max} = 50\text{ A}$) and S3 ($I_{n\max} = 100\text{ A}$) that are designed for control voltages of 230 V AC and 24 V DC. The motor starter protector is fitted into the remote motorized operating mechanism as shown in the drawing.

In the "MANUAL" position, the motor starter protector in the remote motorized operating mechanism can continue to be switched manually on site. In the "AUTOMATIC" position, the motor starter protector is switched by means of electrical commands. The switching command must be applied for a minimum of 100 ms. The remote motorized operating mechanism closes the motor starter protector after a maximum of 1 second. On voltage failure during the switching operation it is ensured that the motor starter protector remains in the OPEN or CLOSED position. In the "MANUAL" and "OFF" position, the remote motorized operating mechanism can be locked with a padlock.

RESET function

The RESET button on the motorized operating mechanism serves to reset any 3RV19 21-1M alarm switch that might be installed.

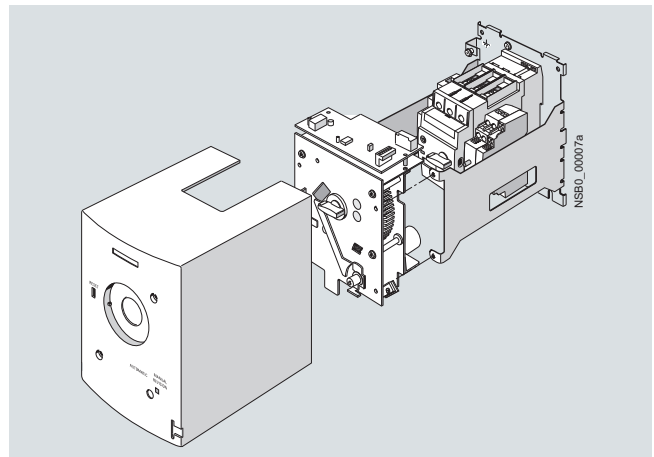

SIRIUS 3RV19 .6-3A.. remote motorized operating mechanism

Motor Starter Protectors

SIRIUS 3RV1 motor starter protectors up to 100 A

Accessories

Rotary operating mechanisms

Selection and ordering data

Version	Color of handle	Version of extension shaft mm	For motor starter protectors Size	DT	Order No.	Price € per PU	PU (UNIT, SET, M)	PS*	PG
---------	-----------------	----------------------------------	--------------------------------------	----	-----------	-------------------	-------------------------	-----	----

Door-coupling rotary operating mechanisms



3RV29 26-0B

The door-coupling rotary operating mechanisms consist of a knob, a coupling driver and a 130/330 mm long extension shaft (6 mm x 6 mm).

The door-coupling rotary operating mechanisms are designed to degree of protection IP64. The door locking device prevents accidental opening of the control cabinet door in the ON position of the motor starter protector. The OFF position can be locked with up to 3 padlocks.

Door-coupling rotary operating mechanisms	Black	130	S0, S2, S3	▶	3RV29 26-0B		1	1 unit	41E
		330	S0, S2, S3	▶	3RV29 26-0K		1	1 unit	41E
EMERGENCY-STOP door-coupling rotary operating mechanisms	Red/yellow	130	S0, S2, S3	▶	3RV29 26-0C		1	1 unit	41E
		330	S0, S2, S3	▶	3RV29 26-0L		1	1 unit	41E

Door-coupling rotary operating mechanisms for arduous conditions



3RV29 36-2B

The door-coupling rotary operating mechanisms consist of a knob, a coupling driver, an extension shaft of 300 mm in length (8 mm x 8 mm), a spacer and two metal brackets, into which the motor starter protector is inserted.

The door-coupling rotary operating mechanisms are designed to degree of protection IP65. The door interlocking reliably prevents opening of the control cabinet door in the ON position of the motor starter protector. The OFF position can be locked with up to 3 padlocks.

Laterally mountable auxiliary releases and two-pole auxiliary switches can be used.

The door-coupling rotary operating mechanisms meet the requirements for isolating functions according to IEC 60947-2.

Door-coupling rotary operating mechanisms	Gray	300	S0	▶	3RV29 26-2B		1	1 unit	41E
			S2	▶	3RV29 36-2B		1	1 unit	41E
			S3	▶	3RV29 46-2B		1	1 unit	41E
EMERGENCY-STOP door-coupling rotary operating mechanisms	Red/yellow	300	S0	▶	3RV29 26-2C		1	1 unit	41E
			S2	▶	3RV29 36-2C		1	1 unit	41E
			S3	▶	3RV29 46-2C		1	1 unit	41E

Version	Rated control supply voltage U_s	For motor starter protectors Size	DT	Order No.	Price € per PU	PU (UNIT, SET, M)	PS*	PG
---------	------------------------------------	--------------------------------------	----	-----------	-------------------	-------------------------	-----	----

Remote motorized operating mechanisms



3RV19 .6-3A..

Remote motorized operating mechanisms	AC 50/60 Hz, 230 V	S2	B	▶	3RV19 36-3AP0		1	1 unit	41E
	24 V DC	S2	B	▶	3RV19 36-3AB4		1	1 unit	41E
	AC 50/60 Hz, 230 V	S3	B	▶	3RV19 46-3AP0		1	1 unit	41E
	24 V DC	S3	B	▶	3RV19 46-3AB4		1	1 unit	41E

Motor Starter Protectors

SIRIUS 3RV1 motor starter protectors up to 100 A

Accessories Mounting accessories

Overview

Solder pin connections

Solder pin connections are available for the main contacts and transverse auxiliary switches of size S00 motor starter protectors.

The prepared terminal parts are clamped to the upper and lower screw terminals of the motor starter protectors which allows them to be soldered into printed circuit boards.

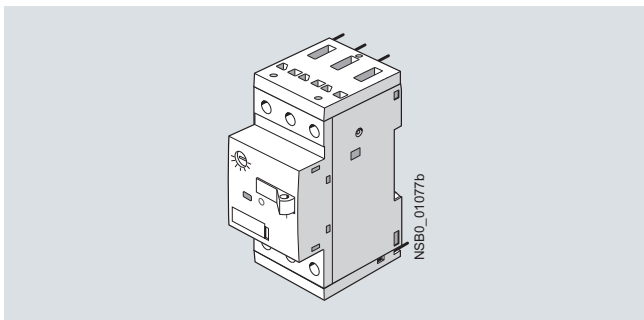

3RV19 18-5A

Terminal blocks for "Self-Protected Combination Motor Controllers (Type E)" according to UL 508

The 3RV10 motor starter protectors size S0 and higher are approved according to UL 508 as "Self-Protected Combination Motor Controllers (Type E)".

This requires increased clearance and creepage distances (1 inch and 2 inches respectively) at the input side of the device, which are achieved by mounting terminal blocks.

- Size S0: The 3RV19 28-1H terminal block is simply screwed onto the basic unit.
- Size S2: The basic unit is already compliant with the increased clearance and creepage distance requirements.
- Size S3: The standard box terminal must be replaced by the 3RT19 46-4GA07 terminal block.

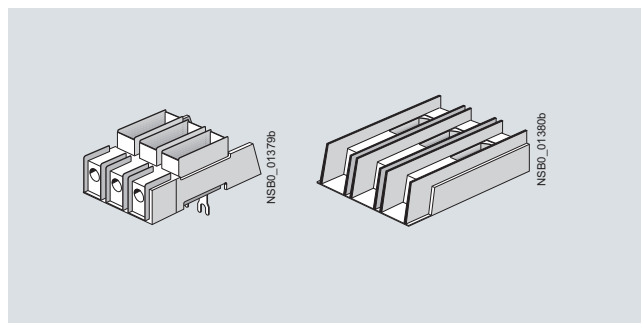

SIRIUS 3RV19 28-1H (left), 3RT19 46-4GA07 (right) terminal blocks (type E)

According to CSA, the terminal blocks can be omitted when the device is used as a "Self-Protected Combination Motor Controller" (Type E).

Three-phase feeder terminals are required for constructing "Type E Starters" with an insulated busbar system (see "Busbar Accessories" on page 7/22).

Selection and ordering data

Accessories

Version	For motor starter protectors Size	DT	Order No.	Price € per PU	PU (UNIT, SET, M)	PS*	PG
---------	--------------------------------------	----	-----------	-------------------	-------------------------	-----	----

Covers



3RV1 (size S3) with 3RT19 46-4EA1 (left) 3RV19 08-0P (right)





Terminal covers for box terminals Additional touch protection to be fitted at the box terminals (2 units mountable per device)	S2	▶	3RT19 36-4EA2		1	1 unit	41B
	S3	▶	3RT19 46-4EA2		1	1 unit	41B
	S3	▶	3RT19 46-4EA1		1	1 unit	41B
Terminal covers For cable lug and busbar connection for maintaining the required voltage clearance and as touch protection if box terminal is removed (2 units can be mounted per motor starter protector)	S3	▶	3RT19 46-4EA1		1	1 unit	41B
Scale covers Sealable, for covering the set current scale	S00, S0, S2, S3	▶	3RV19 08-0P		100	10 units	41E

Motor Starter Protectors

SIRIUS 3RV1 motor starter protectors up to 100 A

Accessories

Mounting accessories

Version	For motor starter protectors Size	DT	Order No.	Price € per PU	PU (UNIT, SET, M)	PS*	PG
Fixing accessories							
	Push-in lugs for screwing the motor starter protector onto mounting plates For each motor starter protector, 2 units are required.	S00, S0	A	3RB19 00-0B	100	10 units	41F
Solder pin connections							
	For main contacts For soldering the main conductor connections of a motor starter protector to a printed circuit board (1 set = 2 units per motor starter protector)	S00	B	3RV19 18-5A	1	4 units	41E
3RV19 18-5A with motor starter protector	For main and auxiliary contacts For soldering the main conductor connections and the auxiliary conductor connections of the transverse auxiliary switch 1 NO + 1 NC of a motor starter protector to a printed circuit board (1 set = 3 units per motor starter protector)	S00	B	3RV19 18-5B	1	4 units	41E
Terminal blocks for "Self-Protected Combination Motor Controllers (Type E)" according to UL 508							
	Note: UL 508 demands 1-inch clearance and 2-inch creepage distance at line side for "Combination Motor Controller Type E". The following terminal blocks must be used in 3RV10 motor starter protectors of sizes S0 and S3. The 3RV10 motor starter protector in size S2 conforms with the required clearance and creepage distances without a terminal block. Terminal blocks are not required for use according to CSA.						
3RV19 28-1H	For construction with three-phase busbars see " Busbar Accessories " on page 7/21 onwards.						
	With size S0, these terminal blocks cannot be used in combination with 3RV19 .5 three-phase busbars and with size S3, they cannot be used with a transverse auxiliary switch.						
3RT19 46-4GA07	Terminal block type E for extended clearance and creepage distances (1 and 2 inch)	S0 S3	▶ B	3RV19 28-1H 3RT19 46-4GA07	1 1	1 unit 1 unit	41E 41E
Auxiliary terminals, 3-pole							
	For connection of auxiliary and control cables to the main conductor connections (for one side)	S3	B	3RT19 46-4F	1	1 unit	41B
3RT19 46-4F							

Motor Starter Protectors

SIRIUS 3RV1 motor starter protectors up to 100 A

Accessories

Mounting accessories

Link modules

Actuating voltage of contactor	Size		DT	Screw terminals		PU (UNIT, SET, M)	PS*	PG
	Contactor	Motor starter protector		Order No.	Price € per PU			
Link modules for motor starter protector to contactor¹⁾								
For mechanical and electrical connection between motor starter protector and contactor with screw terminals								
Single-unit packaging								
AC/DC	S00	S00	▶	3RA19 11-1AA00	1	1 unit	41B	
	S00	S0	▶	3RA19 21-1DA00	1	1 unit	41B	
AC	S0	S0	▶	3RA19 21-1AA00	1	1 unit	41B	
	S2	S2	▶	3RA19 31-1AA00	1	1 unit	41B	
	S3	S3	▶	3RA19 41-1AA00	1	1 unit	41B	
DC	S0	S0	▶	3RA19 21-1BA00	1	1 unit	41B	
	S2	S2	▶	3RA19 31-1BA00	1	1 unit	41B	
	S3	S3	▶	3RA19 41-1BA00	1	1 unit	41B	
Multi-unit packaging								
AC/DC	S00	S00	▶	3RA19 11-1A	1	10 units	41B	
	S00	S0	▶	3RA19 21-1D	1	10 units	41B	
AC	S0	S0	▶	3RA19 21-1A	1	10 units	41B	
	S2	S2	▶	3RA19 31-1A	1	5 units	41B	
	S3	S3	▶	3RA19 41-1A	1	5 units	41B	
DC	S0	S0	▶	3RA19 21-1B	1	10 units	41B	
	S2	S2	▶	3RA19 31-1B	1	5 units	41B	
	S3	S3	▶	3RA19 41-1B	1	5 units	41B	
Hybrid link modules for motor starter protector to contactor¹⁾								
Mechanical and electrical connection between motor starter protector with screw terminals and contactor with spring-type terminals								
Single-unit packaging								
AC/DC	S00	S00	▶	3RA19 11-2FA00	1	1 unit	41B	
	S00	S0	▶	3RA19 21-2FA00	1	1 unit	41B	
Multi-unit packaging								
AC/DC	S00	S00	▶	3RA19 11-2F	1	10 units	41B	
	S00	S0	▶	3RA19 21-2F	1	10 units	41B	



3RA19 31-1AA00



3RA19 41-1AA00



3RA19 31-1A



3RA19 11-2FA00



3RA19 11-2F

Motor Starter Protectors



SIRIUS 3RV1 motor starter protectors up to 100 A

Accessories

Mounting accessories

Version	For motor starter protectors	DT	Spring-type terminals	PU (UNIT, SET, M)	PS*	PG
Size		Order No.	Price € per PU			

Adapters and link modules for spring-type terminals

 <p>3RA19 11-2A + 8US10 51-5CM47</p>	Link modules Electrical connection between motor starter protector and contactor (busbar adapter not included in scope of supply)	S00	▶	3RA19 11-2A	1	10 units	41B
	Link modules with mechanical connection mechanical and electrical connection between motor starter protector and contactor	S00	▶	3RA19 11-2E	1	10 units	41B
	Standard mounting rail adapters with 2 standard mounting rails 45 mm wide, one movable	S00	▶	3RA19 22-1L	1	5 units	41B
 <p>3RA19 11-2E</p>	Busbar adapters 45 mm wide, 182 mm long, adapted for motor starter protectors with spring-type terminals. If there is an additional contactor, a further standard mounting rail must be fitted.	40 mm busbar system	▶	8US10 51-5CM47	1	1 unit	143
		60 mm busbar system	▶	8US12 51-5CM47	1	1 unit	143
	TH 35 standard mounting rails 45 mm wide, plastic, including fixing screws	--	A	8US19 98-7CA15	1	10 units	143

Version	Size	Color	For motor starter protectors	DT	Spring-type terminals	PU (UNIT, SET, M)	PS*	PG
Size		Order No.	Price € per PU					

Tools for opening spring-type terminals

 <p>3RA29 08-1A</p>	Screwdrivers For all SIRIUS devices with spring-type terminals	Length approx. 200 mm, 3.0 mm x 0.5 mm	Titanium gray/black, partially insulated	S00, S0, S2, S3	A	3RA29 08-1A	1	1 unit	41B
--	--	--	--	-----------------	---	--------------------	---	--------	-----

Motor Starter Protectors

SIRIUS 3RV1 motor starter protectors up to 100 A

Accessories Enclosures and front plates

Overview

Enclosures

For installing motor starter protectors in sizes S00 ($I_{n\max} = 12\text{ A}$), S0 ($I_{n\max} = 25\text{ A}$) and S2 ($I_{n\max} = 50\text{ A}$) as a single unit, molded-plastic and cast aluminum enclosures for surface mounting and molded-plastic enclosures for flush mounting are available in various dimensions.

When installed in a molded-plastic enclosure the motor starter protectors have a rated operational voltage U_e of 500 V.

The enclosures for surface mounting have the degree of protection IP55; the enclosures for flush mounting also comply with the degree of protection IP55 at the front (the flush-mounted section complies with IP20).

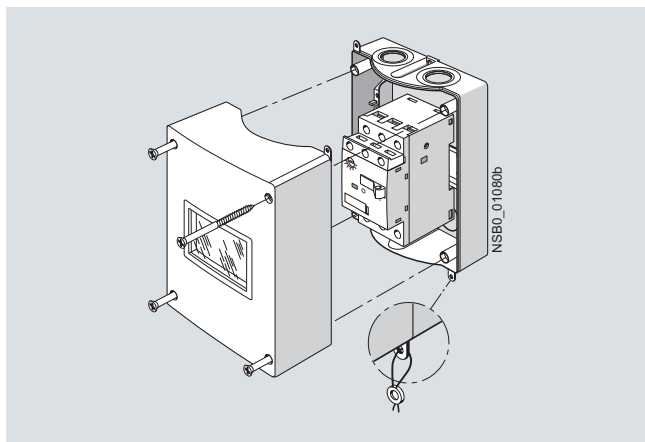

Enclosures for surface mounting

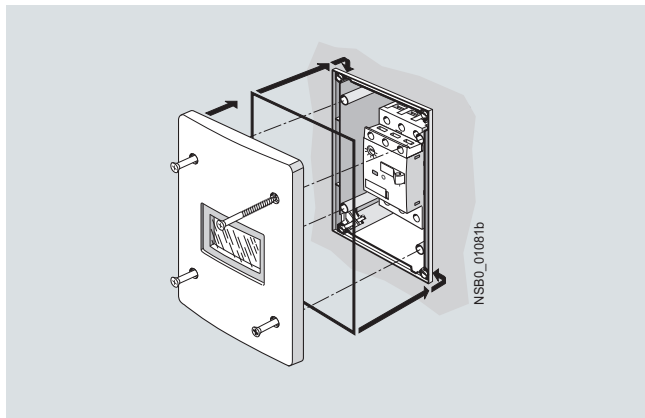

Enclosures for flush mounting

All enclosures are equipped with N and PE terminals. There are two knock-out cable entries for cable glands at the top and two at the bottom; also on the rear corresponding cable entries are scored. There is a knockout on the top of the enclosure for indicator lights that are available as accessories.

The narrow enclosure can accommodate a motor starter protector without accessories, with transverse and lateral auxiliary switch, whereas wide enclosures and enclosures for S2 motor starter protectors also provide space for a laterally mounted auxiliary release. There is no provision for installing a motor starter protector with a signaling switch.

With S00 motor starter protectors, the switch rocker is operated by means of the actuator diaphragm of the enclosure. A locking device, capable of holding up to three padlocks, can be fitted onto the actuator diaphragm to prevent the circuit breaker from closing during maintenance work, for example.

A mushroom-shaped EMERGENCY-STOP knob can be fitted in place of the locking device. If it is actuated abruptly, the motor starter protector opens and the mushroom-shaped knob latches. The knob can be unlatched again either by turning it or by using a special key. The motor starter protector can subsequently be switched on again.

The molded-plastic enclosures of the size S0 and S2 motor starter protectors are fitted with a rotary operating mechanism.

The enclosures can be supplied with either a black rotary operating mechanism or with an EMERGENCY-STOP rotary operating mechanism with a red/yellow knob.

The rotary operating mechanisms can be locked in the Open position with up to 3 padlocks.

Front plates

Motor starter protectors are frequently required to be actuated in any enclosure. Front plates equipped with an actuator diaphragm for size S00 motor starter protectors, or rotary operating mechanism for S0 to S3 motor starter protectors are available for this purpose.

The front plates for size S00 have a holder into which the motor starter protector can be snapped. A holder for size S0 motor starter protectors is available for front plate sizes S0 to S3.

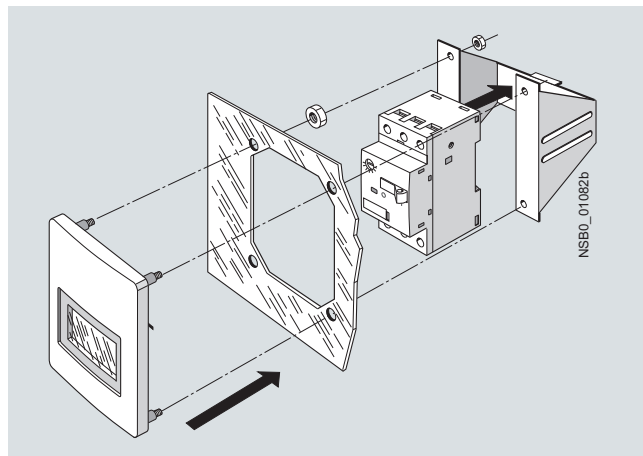

Front plate for size S00

Accessories for enclosures and front plates

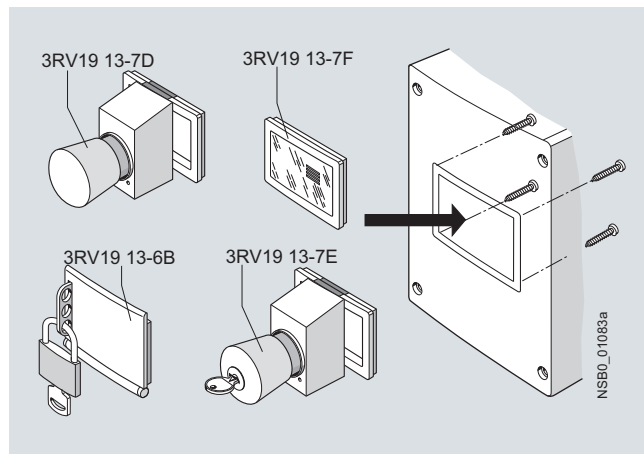







Accessories for size S00

Motor Starter Protectors

SIRIUS 3RV1 motor starter protectors up to 100 A

Accessories
Enclosures and front plates

Selection and ordering data

Version	Degree of protection	Integrated terminals	Mounting width	For 3RV10 to 3RV16 motor starter protectors Size	DT	Order No.	Price € per PU	PU (UNIT, SET, M)	PS*	PG
Molded-plastic enclosures for surface mounting										
 3RV19 13-1DA00	with actuator diaphragm	IP55	N and PE/ground	54 mm (for switch + lateral auxiliary switch)	S00	▶	3RV19 13-1CA00	1	1 unit	41E
				72 mm (for switch + lateral auxiliary switch + auxiliary release)	S00	▶	3RV19 13-1DA00	1	1 unit	41E
 3RV19 23-1FA00	With rotary operating mechanism, lockable in 0 position	IP55	N and PE/ground	54 mm (for switch + lateral auxiliary switch)	S0	▶	3RV19 23-1CA00	1	1 unit	41E
				72 mm (for switch + lateral auxiliary switch + auxiliary release)	S0	▶	3RV19 23-1DA00	1	1 unit	41E
				82 mm (for switch + lateral auxiliary switch + auxiliary release)	S2	A	3RV19 33-1DA00	1	1 unit	41E
 3RV19 23-1GA00	With EMERGENCY-STOP rotary operating mechanism, lockable in 0 position	IP55	N and PE/ground	54 mm (for switch + lateral auxiliary switch)	S0	▶	3RV19 23-1FA00	1	1 unit	41E
				72 mm (for switch + lateral auxiliary switch + auxiliary release)	S0	A	3RV19 33-1GA00	1	1 unit	41E
				82 mm (for switch + lateral auxiliary switch + auxiliary release)	S2	A	3RV19 33-1GA00	1	1 unit	41E
Cast aluminum enclosures for surface mounting										
 3RV19 23-1DA01	With rotary operating mechanism, lockable in 0 position	IP65	PE ¹⁾	72 mm (for switch + lateral auxiliary switch + auxiliary release)	S0	▶	3RV19 23-1DA01	1	1 unit	41E
	With EMERGENCY-STOP rotary operating mechanism, lockable in 0 position	IP65	PE ¹⁾	72 mm (for switch + lateral auxiliary switch + auxiliary release)	S0	▶	3RV19 23-1GA01	1	1 unit	41E
Molded-plastic enclosures for flush mounting										
 3RV19 13-2DA00	with actuator diaphragm	IP55 (front side)	N and PE/ground	72 mm (for switch + lateral auxiliary switch + auxiliary release)	S00	A	3RV19 13-2DA00	1	1 unit	41E
	With rotary operating mechanism, lockable in 0 position	IP55 (front side)	N and PE/ground	72 mm (for switch + lateral auxiliary switch + auxiliary release)	S0	A	3RV19 23-2DA00	1	1 unit	41E
 3RV19 23-2GA00	With EMERGENCY-STOP rotary operating mechanism, lockable in 0 position	IP55 (front side)	N and PE/ground	72 mm (for switch + lateral auxiliary switch + auxiliary release)	S0	A	3RV19 23-2GA00	1	1 unit	41E

¹⁾ If required, an additional N terminal can be mounted (e. g. 8WA1 011-1BG11).

Motor Starter Protectors

SIRIUS 3RV1 motor starter protectors up to 100 A

Accessories

Enclosures and front plates

Version	Degree of protection	For 3RV10 to 3RV16 motor starter protectors Size	DT	Order No.	Price € per PU	PU (UNIT, SET, M)	PS*	PG
---------	----------------------	--	----	-----------	----------------	-------------------	-----	----

Front plates



3RV19 13-4C

Molded-plastic front plates with actuator diaphragm

For actuating 3RV1 motor starter protectors in any enclosures, includes holder for motor starter protector.

IP55 (front side)

S00

A

3RV19 13-4C

1

1 unit

41E



3RV19 23-4B + 3RV19 23-4G

Molded-plastic front plates with rotary operating mechanism

Lockable in 0 position

For actuation of 3RV1 motor starter protectors in any enclosure.

IP55 (front side)

S0, S2, S3

▶

3RV19 23-4B

1

1 unit

41E

Molded-plastic front plates with EMERGENCY-STOP rotary operating mechanism, red/yellow

Lockable in 0 position

EMERGENCY-STOP actuation of 3RV1 motor starter protectors in any enclosure.

IP55 (front side)

S0, S2, S3

A

3RV19 23-4E

1

1 unit

41E

Holders for front plates

Holder is mounted on front plate, motor starter protector with and without accessories is snapped in.

--

S0

▶

3RV19 23-4G

1

1 unit

41E

Accessories for enclosures



Molded-plastic enclosure for surface mounting with 3RV19 13-7D

EMERGENCY-STOP mushroom buttons, red/yellow

For 3RV19 13-... enclosures and front panels

Latching mushroom button, unlatch by turning

Cannot be used in combination with locking device

IP55

S00

▶

3RV19 13-7D

1

1 unit

41E

EMERGENCY-STOP mushroom buttons, red/yellow, with lock

For 3RV19 13-... enclosures and front panels

RONIS lock, lock No. SB 30, supplied with 2 keys

Latching mushroom button, unlatch with key

Cannot be used in combination with locking device

IP55

S00

▶

3RV19 13-7E

1

1 unit

41E

Locking devices

For 3RV19 13-... enclosures and front plates

For 3 padlocks with max. 8 mm shackle diameter.

Cannot be used in combination with EMERGENCY-STOP mushroom button

IP55

S00

▶

3RV19 13-6B

1

1 unit

41E

Spare actuator diaphragms

Holders and screws are included in scope of supply

IP55

S00

A

3RV19 13-7F

1

1 unit

41E

Version	Rated control supply voltage U_s V	For motor starter protectors Size	DT	Order No.	Price € per PU	PU (UNIT, SET, M)	PS*	PG
---------	--------------------------------------	-----------------------------------	----	-----------	----------------	-------------------	-----	----

Indicator lights



3RV19 03-5B

Indicator lights

for all enclosures and front plates

With glow lamp and colored lenses red, green, yellow, orange and clear

110 ... 120

220 ... 240

380 ... 415

480 ... 500

S2

C

3RV19 03-5B

1

1 unit

41E

C

3RV19 03-5C

1

1 unit

41E

C

3RV19 03-5E

1

1 unit

41E

C

3RV19 03-5G

1

1 unit

41E

Motor Starter Protectors

SIRIUS 3RV1 motor starter protectors up to 100 A

3RV19 infeed systems

Overview

The 3RV19 infeed system is a convenient means of energy supply and distribution for a group of several motor starter protectors or complete load feeders with a screw or spring-type connection up to size S0 (exception: this system cannot be used for the 3RV11, 3RV16 to 3RV18 motor starter protectors/circuit breakers).

The devices with spring-type connections are available in the SIRIUS modular system up to 5.5 kW at 400 V AC. The motor starter protectors and load feeders with screw terminals for sizes S00 and S0 can also be integrated in the system at the same time.

The system is based on a basic module complete with a lateral incoming unit (three-phase busbar with infeed). This infeed with spring-type terminals is mounted on the right or left depending on the version and can be supplied with a maximum conductor cross-section of 25 mm² (with end sleeve). A basic module has two sockets into each of which a motor starter protector can be snapped.

Expansion modules are available for extending the system (three-phase busbars for system expansion). The individual modules are connected through an expansion plug.

The electrical connection between the three-phase busbars and the motor starter protectors is implemented through plug-in connectors. The complete system can be mounted on a TH 35 standard mounting rail to IEC 60715 and can be expanded as required up to a maximum current carrying capacity of 63 A.

The system is mounted extremely quickly and easily thanks to the simple plug-in technique. Thanks to the lateral infeed, the system also saves space in the control cabinet. The additional overall height required for the infeed unit is only 30 mm. The alternative infeed possibilities on each side offer a high degree of flexibility for configuring the control cabinet: Infeed on left-hand or right-hand side, ring infeed or infeed on one side and outfeed from the other side to supply further loads are all possible. A terminal block with spring-type connections in combination with a standard mounting rail enables the integration of not only SIRIUS motor starter protectors but also single-phase, two-phase and three-phase components such as 5SY miniature circuit breakers or SIRIUS relay components.

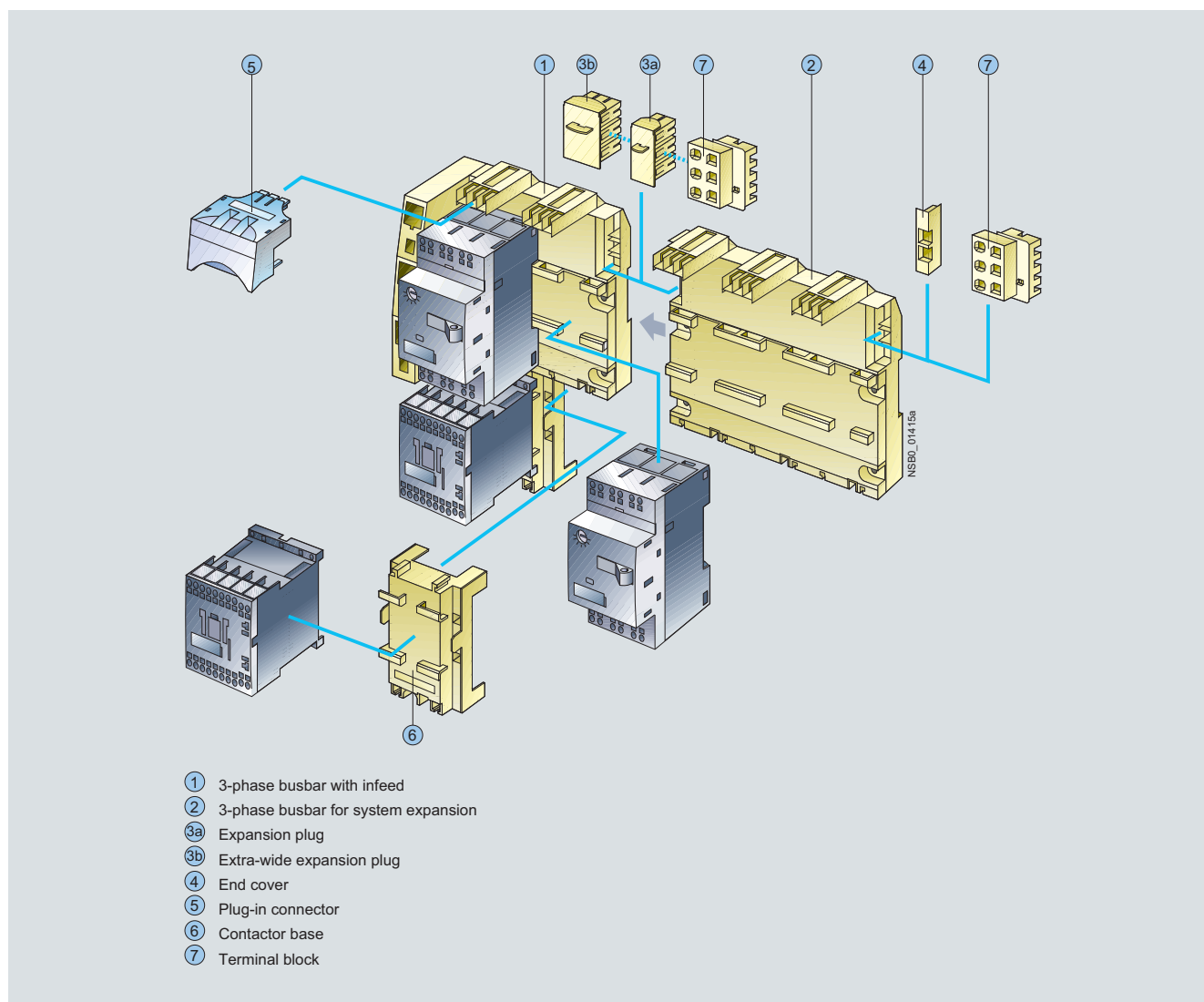

SIRIUS 3RV19 infeed system

Motor Starter Protectors

SIRIUS 3RV1 motor starter protectors up to 100 A

3RV19 infeed systems

① **Three-phase busbars with infeed**

A three-phase busbar with infeed unit is required for connecting the energy supply. These modules comprise one infeed module and 2 sockets which each accept one motor starter protector. A choice of two versions with infeed on the left or right is available. The infeed is connected using spring-type terminals. They permit an infeed with conductor cross-sections of up to 25 mm² with end sleeves. An end cover is supplied with each module.

② **Three-phase busbars for system expansion**

The three-phase busbars for system expansion allow the system to be expanded. There is a choice of modules with 2 or 3 sockets. The system can be expanded as required up to a maximum current carrying capacity of 63 A. An expansion plug is supplied with each module.

③a **Expansion plug**

The expansion plug is used for electrical connection of adjacent three-phase busbars. The current carrying capacity of this plug equals 63 A. One expansion plug is supplied with each three-phase busbar for system expansion. Additional expansion plugs are therefore only required as spare parts.

③b **Extra-wide expansion plug**

The wide expansion plug makes the electrical connection between two 3-phase busbars, thus performing the same function as the 3RV19 17-5BA00 expansion plug; the electrical characteristics (e. g. a current carrying capacity of 63 A) are identical.

The 3RV19 17-5E expansion plug is 10 mm wider than the 3RV19 17-5BA00 expansion plug, hence in the plugged state there is a distance of 10 mm between the connected 3-phase busbars. This distance can be used to lay the auxiliary current and control current wiring ("wiring duct"). The motor starter protector and contactor can be wired from underneath, which means that the complete cable duct above the system can be omitted.

④ **End cover**

The end cover is used to cover the three-phase busbar at the open end of the system. This cover is therefore only required once for each system. An end cover is supplied with each three-phase busbar system with infeed. Further end covers are therefore only required as spare parts.

⑤ **Plug-in connector**

The plug-in connector is used for the electrical connection between the three-phase busbar and the motor starter protector. These plug-in connectors are available in versions with screw terminals for sizes S00, S0 or with spring-type terminals for size S00.

⑥ **Contactor base**

Load feeders can be assembled in the system using the contactor base. The contactor bases are suitable for contactors of size S00 with spring-type terminals and are simply snapped onto the 3-phase busbars. Direct-on-line starters and reversing starters are possible. One contactor base is required for direct-on-line starters and two are required for reversing starters. To assemble load feeders for reversing starters, the contactor bases can be arranged either below each other (45 mm overall width) or alongside each other (90 mm overall width). It is important to note that mechanical interlocking of the contactors is only possible when they are arranged vertically.

The infeed system is designed for mounting on a TH 35 standard mounting rail with 7.5 mm overall depth. This standard mounting rail gives the contactor base a stable mounting surface to sit on. If standard mounting rails with a depth of 15 mm are used, the spacer connected to the bottom of the contactor base must be knocked out and plugged into the mating piece that is also on the underside. Then the contactor base also has a stable mounting surface. When standard mounting rails with a depth of 7.5 mm are used, the spacer has no function and can be removed.

As an alternative to using a contactor base, the 3RA19 11-2E electrical link modules can also be used for direct start load feeders with spring-type connections of size S00. Motor starter protector and contactor assemblies can then be directly snapped onto the sockets of the three-phase busbars. For feeders of size S00 and S0, the corresponding 3RA19 11-1.... or 3RA19 21-1.... link modules should generally be used. For size S0, it is only possible integrate direct start load feeders and they must be integrated in the system as complete assemblies.

⑦ **Terminal block**





The 3RV19 17-5D terminal block enables the integration of not only SIRIUS motor starter protectors but also single-phase, 2-phase and 3-phase components. Using the terminal block the 3 phases can be fed out of the system; which means that single-phase loads can also be integrated in the system. The terminal block is plugged into the slot of the expansion plug and thus enables outfeeding from the middle or end of the infeed system. The terminal block can be rotated through 180° and be locked to the support modules of the infeed system. The 3RV19 17-7B 45 mm wide TH 35 standard mounting rail for screwing onto the support plate is available in addition in order to be able to plug the single-phase, 2-phase and 3-phase components onto the infeed system.

Motor Starter Protectors

SIRIUS 3RV1 motor starter protectors up to 100 A

3RV19 infeed systems

Selection and ordering data

Type	Version	For motor starter protectors	DT	Order No.	Price € per PU	PU (UNIT, SET, M)	PS*	PG
		Size						
Three-phase busbars with infeed								
	Three-phase busbars with infeed incl. 3RV19 17-6A end cover	For 2 motor starter protectors with infeed from the left	S00 (spring-type) ¹⁾ , S00, S0 (screw)	A	3RV19 17-1A	1	1 unit	41E
		For 2 motor starter protectors with infeed from the right	S00 (spring-type) ¹⁾ , S00, S0 (screw)	A	3RV19 17-1E	1	1 unit	41E
Three-phase busbars for system expansion								
	Three-phase busbars incl. 3RV19 17-5BA00 expansion plug	For 2 motor starter protectors	S00 (spring-type) ¹⁾ , S00, S0 (screw)	A	3RV19 17-4A	1	1 unit	41E
		For 3 motor starter protectors	S00 (spring-type) ¹⁾ , S00, S0 (screw)	A	3RV19 17-4B	1	1 unit	41E
Plug-in connectors								
	Plug-in connectors to make contact with the motor starter protectors	Single-unit packaging	S00 (spring-type) ¹⁾	A	3RV19 17-5AA00	1	1 unit	41E
		Multi-unit packaging	S00 (spring-type) ¹⁾	A	3RV19 17-5A	1	10 units	41E
		Single-unit packaging	S00 (screw)	A	3RV19 17-5CA00	1	1 unit	41E
			S0 (screw)	A	3RV19 27-5AA00	1	1 unit	41E
		Multi-unit packaging	S00 (screw)	A	3RV19 17-5C	1	10 units	41E
			S0 (screw)	A	3RV19 27-5A	1	10 units	41E

¹⁾ Compatible with the following motor starter protectors: 3RV10 11-...2. (size S00, spring-type) product version E03 and upwards.





Type	Version	For contactors	DT	Order No.	Price € per PU	PU (UNIT, SET, M)	PS*	PG
		Size						
Contactors bases								
	Contactors bases for mounting direct-on-line or reversing starters	Single-unit packaging	S00	A	3RV19 17-7AA00	1	1 unit	41E
		Multi-unit packaging	S00	A	3RV19 17-7A	1	10 units	41E

3RV19 17-7A

Motor Starter Protectors

SIRIUS 3RV1 motor starter protectors up to 100 A

3RV19 infeed systems

Type	Version	DT	Order No.	Price € per PU	PU (UNIT, SET, M)	PS*	PG
Terminal blocks							
	Terminal blocks For integration of single-phase, two-phase and three-phase components	Single-unit packaging	A	3RV19 17-5D	1	1 unit	41E
3RV19 17-5D							
45 mm standard mounting rail							
	TH 35 standard mounting rails, 45 mm wide, for mounting onto three-phase busbars	Single-unit packaging	A	3RV19 17-7B	1	1 unit	41E
3RV19 17-7B							
Extra-wide expansion plugs							
	Extra-wide expansion plugs As accessory	Single-unit packaging	A	3RV19 17-5E	1	1 unit	41E
3RV19 17-5E							
Expansion plugs							
	Expansion plugs¹⁾ as spare part	Single-unit packaging	A	3RV19 17-5BA00	1	1 unit	41E
3RV19 17-5BA00							
End covers							
	End covers²⁾ as spare part	Multi-unit packaging	A	3RV19 17-6A	100	10 units	41E
3RV19 17-6A							

¹⁾ The expansion plug is included in the scope of supply of the 3RV19 17-4 three-phase busbars for system expansion.

²⁾ The end cover is included in the scope of supply of the 3RV19 17-1 three-phase busbars with infeed system.

Overview



Features	3RU11	3RB20/3RB21	3RB22/3RB23	Benefits
General data				
Sizes	S00 ... S3	S00 ... S12	S00 ... S12	<ul style="list-style-type: none"> • Are coordinated with the dimensions, connections and technical characteristics of the other devices in the SIRIUS modular system (contactors, etc., ...) • Permit the mounting of slim and compact load feeders in widths of 45 mm (S00), 45 mm (S0), 55 mm (S2), 70 mm (S3), 120 mm (S6) and 145 mm (S10/S12); this does not include the current measuring modules for the 3RB22 to 3RB23 evaluation modules sizes S00 to S3 • Simplify configuration
Seamless current range	0,11 ... 100 A	0,1 ... 630 A	0,3 ... 630 A (up to 820 A) ¹⁾	<ul style="list-style-type: none"> • Allows easy and consistent configuration with one series of overload relays (for small to large loads)
Protection functions				
Tripping due to overload	✓	✓	✓	<ul style="list-style-type: none"> • Provides optimum inverse-time delayed protection of loads against excessive temperature rises due to overload
Tripping due to phase unbalance	✓	✓	✓	<ul style="list-style-type: none"> • Provides optimum inverse-time delayed protection of loads against excessive temperature rises due to phase unbalance
Tripping due to phase failure	✓	✓	✓	<ul style="list-style-type: none"> • Minimizes heating of induction motors during phase failure
Protection of single-phase loads	✓	--	✓	<ul style="list-style-type: none"> • Enables the protection of single-phase loads
Tripping in the event of overheating	-- ²⁾	-- ²⁾	✓	<ul style="list-style-type: none"> • Provides optimum temperature-dependent protection of loads against excessive temperature rises e. g. for stator-critical motors or in the event of insufficient coolant flow, contamination of the motor surface or for long starting or braking operations • Eliminates the need for additional special equipment • Saves space in the control cabinet • Reduces wiring outlay and costs
by				
integrated thermistor motor protection function				<ul style="list-style-type: none"> • Eliminates the need for additional special equipment • Saves space in the control cabinet • Reduces wiring outlay and costs
Tripping in the event of a ground fault	--	✓ (only 3RB21)	✓	<ul style="list-style-type: none"> • Provides optimum protection of loads against high-resistance short circuits or ground faults due to moisture, condensed water, damage to the insulation material, etc. • Eliminates the need for additional special equipment • Saves space in the control cabinet • Reduces wiring outlay and costs
by				
internal ground-fault detection (activatable)				<ul style="list-style-type: none"> • Reduces wiring outlay and costs
Features				
RESET function	✓	✓	✓	<ul style="list-style-type: none"> • Allows manual or automatic resetting of the device
Remote RESET function	✓ (by means of separate module)	✓ (only with 3RB21 and external auxiliary voltage 24 V DC)	✓ (electrically via external button)	<ul style="list-style-type: none"> • Allows the remote resetting of the device
TEST function for auxiliary contacts	✓	✓	✓	<ul style="list-style-type: none"> • Allows easy checking of the function and wiring
TEST function for electronics	--	✓	✓	<ul style="list-style-type: none"> • Allows checking of the electronics
Status display	✓	✓	✓	<ul style="list-style-type: none"> • Displays the current operating state
Large current adjustment button	✓	✓	✓	<ul style="list-style-type: none"> • Makes it easier to set the relay exactly to the correct current value
Integrated auxiliary contacts (1 NO + 1 NC)	✓	✓	✓ (2 ×)	<ul style="list-style-type: none"> • Allows the load to be switched off if necessary • Can be used to output signals

✓ Available

-- Not available

¹⁾ Motor currents up to 820 A can be recorded and evaluated by a current measuring module, e. g. 3RB29 06-2BG1 (0.3 to 3 A), in combination with a 3UF18 68-3GA00 (820 A/1 A) series transformer. For 3UF18 transformers see Catalog IC 10 · 2012, Chapter 10, "Monitoring and Control Devices" → "SIMOCODE 3UF Motor Management and Control Devices".

²⁾ The SIRIUS 3RN thermistor motor protection devices can be used to provide additional temperature-dependent protection.

Overload Relays

General data



Features	3RU11	3RB20/3RB21	3RB22/3RB23	Benefits
Design of load feeders				
Short-circuit strength up to 100 kA at 690 V (in conjunction with the corresponding fuses or the corresponding motor starter protector)	✓	✓	✓	<ul style="list-style-type: none"> Provides optimum protection of the loads and operating personnel in the event of short circuits due to insulation faults or faulty switching operations
Electrical and mechanical matching to 3RT contactors	✓	✓	✓ ¹⁾	<ul style="list-style-type: none"> Simplifies configuration Reduces wiring outlay and costs Enables stand-alone installation as well as space-saving direct mounting
Straight-through transformers for main circuit²⁾ (in this case the cables are routed through the feed-through openings of the overload relay and connected directly to the box terminals of the contactor)	--	✓ (S2 ... S6)	✓ (S00 ... S6)	<ul style="list-style-type: none"> Reduces the contact resistance (only one point of contact) Saves wiring costs (easy, no need for tools, and fast) Saves material costs Reduces installation costs
Spring-type connection for auxiliary circuits²⁾	✓	✓	✓	<ul style="list-style-type: none"> Enables fast connections Permits vibration-resistant connections Enables maintenance-free connections
Other features				
Temperature compensation	✓	✓	✓	<ul style="list-style-type: none"> Allows the use of the relays at high temperatures without derating Prevents premature tripping Allows compact installation of the control cabinet without distance between the devices/load feeders Simplifies configuration Enables space to be saved in the control cabinet
Very high long-term stability	✓	✓	✓	<ul style="list-style-type: none"> Provides safe protection for the loads even after years of use in severe operating conditions
Wide setting ranges	--	✓ (1:4)	✓ (1:10)	<ul style="list-style-type: none"> Minimize the configuration outlay and costs Minimize storage overheads, storage costs, tied-up capital
Fixed trip class	CLASS 10	CLASS 10 or CLASS 20 (only 3RB20)	--	<ul style="list-style-type: none"> Optimum motor protection for standard starts
Trip classes adjustable on the device, CLASS 5, 10, 20, 30	--	✓ (only 3RB21)	✓	<ul style="list-style-type: none"> Enables solutions for very fast starting motors requiring special protection (e. g. Ex motors) Enables heavy starting solutions Reduces the number of variants Minimizes the configuring outlay and costs Minimizes storage overhead, storage costs, and tied-up capital
Low power loss	--	✓	✓	<ul style="list-style-type: none"> Reduces power consumption and energy costs (up 98 % less power is used than for thermal overload relays). Minimizes temperature rises of the contactor and control cabinet – in some cases this may eliminate the need for controlgear cabinet cooling. Direct mounting to contactor saves space, even for high motor currents (i. e. no heat decoupling is required).

✓ Available

-- Not available

¹⁾ Exception: up to size S3, only stand-alone installation is possible.²⁾ Alternatively available for screw terminals.



Features	3RU11	3RB20/3RB21	3RB22/3RB23	Benefits
Further characteristics (continued)				
Internal power supply	-- ¹⁾	✓	--	<ul style="list-style-type: none"> Eliminates the need for configuration and connecting an additional control circuit
Variable adjustment of the trip classes (The required trip class can be adjusted by means of a rotary switch depending on the current start-up condition.)	--	✓ (only 3RB21)	✓	<ul style="list-style-type: none"> Reduces the number of variants Minimizes the configuring outlay and costs Minimizes storage overhead, storage costs, and tied-up capital
Overload warning	--	--	✓	<ul style="list-style-type: none"> Indicates imminent tripping of the relay directly on the device due to overload, phase unbalance or phase failure through flickering of the LEDs Allows the imminent tripping of the relay to be signaled Allows measures to be taken in time in the event of inverse-time delayed overloading of the load for an extended period over the current limit Eliminates the need for an additional device Saves space in the control cabinet Reduces wiring outlay and costs
Analog output	--	--	✓	<ul style="list-style-type: none"> Allows the output of an analog output signal for actuating moving-coil instruments, feeding programmable logic controllers or transfer to bus systems Eliminates the need for an additional measuring transducer and signal converter Saves space in the control cabinet Reduces wiring outlay and costs





✓ Available
 -- Not available

¹⁾ The SIRIUS 3RU11 thermal overload relays use a bimetal contactor and therefore do not require a control supply voltage.

Overload Relays

General data

Overload relays overview – matching contactors

Overload relays	Current measurement	Current range	Contactors (type, size, rating in kW)								
			3RT10 1.	3RT10 2.	3RT10 3.	3RT10 4.	3RT10 5.	3RT10 6.	3RT10 7	3TF68/3TF69	
Type	Type	A	S00	S0	S2	S3	S6	S10	S12	Size 14	
			3/4/5,5	5,5/7,5/11	15/18,5/22	30/37/45	55/75/90	110/132/160	200/250	375/450	
SIRIUS 3RU11 thermal overload relays											
	3RU11 1	Integrated	0,11 ... 12	✓	--	--	--	--	--	--	
	3RU11 2	Integrated	1,8 ... 25	--	✓	--	--	--	--	--	
	3RU11 3	Integrated	5,5 ... 50	--	--	✓	--	--	--	--	
	3RU11 4	Integrated	18 ... 100	--	--	--	✓	--	--	--	
SIRIUS 3RB20 solid-state overload relays¹⁾											
	3RB20 1	Integrated	0,1 ... 12	✓	--	--	--	--	--	--	
	3RB20 2	Integrated	0,1 ... 25	--	✓	--	--	--	--	--	
	3RB20 3	Integrated	6 ... 50	--	--	✓	--	--	--	--	
	3RB20 4	Integrated	12,5 ... 100	--	--	--	✓	--	--	--	
	3RB20 5	Integrated	50 ... 200	--	--	--	--	✓	--	--	
	3RB20 6	Integrated	55 ... 630	--	--	--	--	--	✓	✓	
3RB20 1 + 3UF18	Integrated	630 ... 820	--	--	--	--	--	--	--	✓	
SIRIUS 3RB21 solid-state overload relays¹⁾											
	3RB21 1	Integrated	0,1 ... 12	✓	--	--	--	--	--	--	
	3RB21 2	Integrated	0,1 ... 25	--	✓	--	--	--	--	--	
	3RB21 3	Integrated	6 ... 50	--	--	✓	--	--	--	--	
	3RB21 4	Integrated	12,5 ... 100	--	--	--	✓	--	--	--	
	3RB21 5	Integrated	50 ... 200	--	--	--	--	✓	--	--	
	3RB21 6	Integrated	55 ... 630	--	--	--	--	--	✓	✓	
3RB21 1 + 3UF18	Integrated	630 ... 820	--	--	--	--	--	--	--	✓	
SIRIUS 3RB22/3RB23 solid-state overload relays¹⁾											
	3RB29 0	0,3 ... 25	✓	✓	--	--	--	--	--	--	
	3RB22 83/3RB23 83	10 ... 100	✓	✓	✓	✓	--	--	--	--	
		20 ... 200	--	--	--	--	✓	--	--	--	
		63 ... 630	--	--	--	--	--	✓	✓	✓	
		630 ... 820	--	--	--	--	--	--	--	--	✓

✓ Can be used
-- Cannot be used

¹⁾ "Technical Specifications" for use of the overload relays with trip class \geq CLASS 20 can be found in "Short-circuit protection with fuses for motor feeders", see "Reference Manual for Protection Equipment – 3RU1, 3RB2 Overload Relays" and in the Configuration Manual "SIRIUS Configuration – Selection Data for Fuseless Load Feeders", Order No. 3ZX1012-0RA21-0AC0.

Connection methods

The 3RU11 thermal overload relays come with screw terminals.

The 3RB20 and 3RB21 solid-state overload relays are available with screw terminals (box terminals) or spring-type terminals on the auxiliary current side; the same applies for the evaluation modules of the 3RB22 to 3RB23 solid-state overload relays for High-Feature application.



Screw terminals



Spring-type terminals

The terminals are indicated in the corresponding tables by the symbols shown on orange backgrounds.

Overload Relays

SIRIUS 3RU1 Thermal Overload Relays

3RU11 up to 100 A
for standard applications

Overview

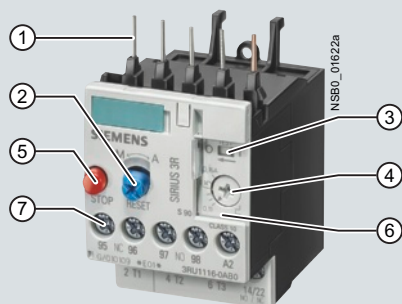

- ① Connection for mounting onto contactors:
Optimally adapted in electrical, mechanical and design terms to the contactors. Connecting pins can be used for direct mounting of the overload relays. Stand-alone installation is possible as an alternative (in some cases in conjunction with a stand-alone installation module).
- ② Selector switch for manual/automatic RESET and RESET button:
With this switch you can choose between manual and automatic RESET. A device set to manual RESET can be reset locally by pressing the RESET button. A remote RESET is possible using the RESET modules (accessories), which are independent of size.
- ③ Switch position indicator and TEST function of the wiring:
Indicates a trip and enables the wiring test.
- ④ Motor current setting:
Setting the device to the rated motor current is easy with the large rotary knob.
- ⑤ STOP button:
If the STOP button is pressed, the NC contact is opened. This switches off the contactor downstream. The NC contact is closed again when the button is released.
- ⑥ Transparent, sealable cover:
Secures the motor current setting and the TEST function against adjustment.
- ⑦ Supply terminals:
The generously sized terminals permit connection of two conductors with different cross-sections for the main and auxiliary circuits. The auxiliary circuit can be connected with screw terminals and alternatively with spring-type terminals.

The 3RU11 thermal overload relays up to 100 A have been designed for inverse-time delayed protection of loads with normal starting ("Function" see [Reference Manual for Protection Equipment – 3RU1, 3RB2 Overload Relays](#)) against excessive temperature rises due to overload or phase failure.

An overload or phase failure results in an increase of the motor current beyond the set rated motor current. Via heating elements, this current rise heats up the bimetal strips inside the device which then bend and as a result trigger the auxiliary contacts by means of a tripping mechanism. The auxiliary contacts then switch off the load by means of a contactor. The break time depends on the ratio between the tripping current and current setting I_e and is stored in the form of a long-term stable tripping characteristic see www.siemens.com/sirius/support → "Characteristic Curves".

The "tripped" status is signaled by means of a switch position indicator. Resetting takes place either manually or automatically after a recovery time has elapsed ("Function" see ["Reference Manual for Protection Equipment – 3RU1, 3RB2 Overload Relays"](#)).

The devices are manufactured in accordance with environmental guidelines and contain environmentally-friendly and reusable materials.

They comply with all important worldwide standards and approvals.

"Increased safety" type of protection EEx e according to ATEX directive 94/9/EC

The 3RU11 thermal overload relays are suitable for the overload protection of explosion-proof motors with "increased safety" type of protection EEx e. The relays meet the requirements of EN 60079-7 (Electrical apparatus for areas subject to explosion hazards - Increased safety "e"); see www.siemens.com/sirius/atex.

EC prototype test certificate for Category (2) G/D exists. It has the number DMT 98 ATEX G 001.

SIRIUS 3RU11 16-0AB0 thermal overload relay

Order No. scheme

Digit of the Order No.	1st - 3rd	4th	5th	6th	7th	8th	9th	10th	11th
	□ □ □	□	□	□	□	-	□	□	□ □
Thermal overload relays	3 R U								
SIRIUS 1st generation		1							
Device series			□						
Size, rated operational current and power				□	□				
Setting range of the overload release							□	□	
Connection methods								□	
Installation type									□
Example	3 R U	1	1	3	6	-	1	H	B 0

Note:

The Order No. scheme is presented here merely for information purposes and for better understanding of the logic behind the order numbers.

For your orders, please use the order numbers quote in the catalog in the Selection and ordering data.

Overload Relays

SIRIUS 3RU1 Thermal Overload Relays

**3RU11 up to 100 A
for standard applications**

Benefits

The most important features and benefits of the 3RU11 thermal overload relays are listed in the overview table (see "General Data", page 7/37 onwards).

Application

Industries

The 3RU11 thermal overload relays are suitable for customers from all industries who want to guarantee optimum inverse-time delayed protection of their electrical loads (e. g. motors) under normal starting conditions (CLASS 10).

Application

The 3RU11 thermal overload relays have been designed for the protection of three-phase and single-phase AC and DC motors.

If single-phase AC or DC loads are to be protected by the 3RU11 thermal overload relays, all three bimetal strips must be heated. For this purpose, all main current paths of the relay must be connected in series.

Ambient conditions

The 3RU11 thermal overload relays have temperature compensation in accordance with IEC 60947-4-1 for the temperature range of –20 to +60 °C. For temperatures from +60 to +80 °C the upper set value of the setting range must be reduced by the factor listed in the table below.

Ambient temperature in °C	Derating factor for the upper set value
+60	1,0
+65	0,94
+70	0,87
+75	0,81
+80	0,73

Overload Relays

SIRIUS 3RU1 Thermal Overload Relays

3RU11 up to 100 A
for standard applications





Selection and ordering data

3RU11 thermal overload relays with screw terminals on the auxiliary current side for mounting onto contactor¹⁾, CLASS 10

Features and technical specifications:

- Overload and phase failure protection
- Auxiliary contacts 1 NO + 1 NC
- Manual and automatic RESET

- Switch position indicator
- TEST function
- STOP button
- Integrated, sealable cover

Size of contactor ²⁾	Rating for induction motor P ³⁾	Current setting of the inverse-time delayed overload release	Short-circuit protection with fuse, type of coordination "2", gG operational class ⁴⁾	DT	Screw terminals (on auxiliary current side)	PU (UNIT, SET, M)	PS*	PG	
									Order No.
Size S00									
 3RU11 16..B0	S00	0,04	0,11 ... 0,16	0,5	▶	3RU11 16-0AB0	1	1 unit	41F
		0,06	0,14 ... 0,2	1	▶	3RU11 16-0BB0	1	1 unit	41F
		0,06	0,18 ... 0,25	1	▶	3RU11 16-0CB0	1	1 unit	41F
		0,09	0,22 ... 0,32	1,6	▶	3RU11 16-0DB0	1	1 unit	41F
		0,09	0,28 ... 0,4	2	▶	3RU11 16-0EB0	1	1 unit	41F
	0,12	0,35 ... 0,5	2	▶	3RU11 16-0FB0	1	1 unit	41F	
	0,18	0,45 ... 0,63	2	▶	3RU11 16-0GB0	1	1 unit	41F	
	0,18	0,55 ... 0,8	4	▶	3RU11 16-0HB0	1	1 unit	41F	
	0,25	0,7 ... 1	4	▶	3RU11 16-0JB0	1	1 unit	41F	
	0,37	0,9 ... 1,25	4	▶	3RU11 16-0KB0	1	1 unit	41F	
	0,55	1,1 ... 1,6	6	▶	3RU11 16-1AB0	1	1 unit	41F	
	0,75	1,4 ... 2	6	▶	3RU11 16-1BB0	1	1 unit	41F	
	0,75	1,8 ... 2,5	10	▶	3RU11 16-1CB0	1	1 unit	41F	
	1,1	2,2 ... 3,2	10	▶	3RU11 16-1DB0	1	1 unit	41F	
	1,5	2,8 ... 4	16	▶	3RU11 16-1EB0	1	1 unit	41F	
	1,5	3,5 ... 5	20	▶	3RU11 16-1FB0	1	1 unit	41F	
	2,2	4,5 ... 6,3	20	▶	3RU11 16-1GB0	1	1 unit	41F	
3	5,5 ... 8	25	▶	3RU11 16-1HB0	1	1 unit	41F		
4	7 ... 10	35	▶	3RU11 16-1JB0	1	1 unit	41F		
5,5	9 ... 12	35	▶	3RU11 16-1KB0	1	1 unit	41F		
Size S0									
 3RU11 26..B0	S0	0,75	1,8 ... 2,5	10	▶	3RU11 26-1CB0	1	1 unit	41F
		1,1	2,2 ... 3,2	10	▶	3RU11 26-1DB0	1	1 unit	41F
		1,5	2,8 ... 4	16	▶	3RU11 26-1EB0	1	1 unit	41F
		1,5	3,5 ... 5	20	▶	3RU11 26-1FB0	1	1 unit	41F
		2,2	4,5 ... 6,3	20	▶	3RU11 26-1GB0	1	1 unit	41F
	3	5,5 ... 8	25	▶	3RU11 26-1HB0	1	1 unit	41F	
	4	7 ... 10	35	▶	3RU11 26-1JB0	1	1 unit	41F	
	5,5	9 ... 12,5	35	▶	3RU11 26-1KB0	1	1 unit	41F	
	7,5	11 ... 16	40	▶	3RU11 26-4AB0	1	1 unit	41F	
	7,5	14 ... 20	50	▶	3RU11 26-4BB0	1	1 unit	41F	
	11	17 ... 22	63	▶	3RU11 26-4CB0	1	1 unit	41F	
	11	20 ... 25	63	▶	3RU11 26-4DB0	1	1 unit	41F	
	Size S2								
 3RU11 36..B0	S2	3	5,5 ... 8	25	▶	3RU11 36-1HB0	1	1 unit	41F
		4	7 ... 10	35	▶	3RU11 36-1JB0	1	1 unit	41F
		5,5	9 ... 12,5	35	▶	3RU11 36-1KB0	1	1 unit	41F
	7,5	11 ... 16	40	▶	3RU11 36-4AB0	1	1 unit	41F	
	7,5	14 ... 20	50	▶	3RU11 36-4BB0	1	1 unit	41F	
	11	18 ... 25	63	▶	3RU11 36-4DB0	1	1 unit	41F	
	15	22 ... 32	80	▶	3RU11 36-4EB0	1	1 unit	41F	
	18,5	28 ... 40	80	▶	3RU11 36-4FB0	1	1 unit	41F	
	22	36 ... 45	100	▶	3RU11 36-4GB0	1	1 unit	41F	
22	40 ... 50	100	▶	3RU11 36-4HB0	1	1 unit	41F		
Size S3									
 3RU11 46..B0	S3	11	18 ... 25	63	▶	3RU11 46-4DB0	1	1 unit	41F
		15	22 ... 32	80	▶	3RU11 46-4EB0	1	1 unit	41F
	18,5	28 ... 40	80	▶	3RU11 46-4FB0	1	1 unit	41F	
	22	36 ... 50	125	▶	3RU11 46-4HB0	1	1 unit	41F	
	30	45 ... 63	125	▶	3RU11 46-4JB0	1	1 unit	41F	
	37	57 ... 75	160	▶	3RU11 46-4KB0	1	1 unit	41F	
	45	70 ... 90	160	▶	3RU11 46-4LB0	1	1 unit	41F	
	45	80 ... 100 ⁵⁾	200	▶	3RU11 46-4MB0	1	1 unit	41F	

1) With the suitable terminal brackets (see "Accessories" on page 7/46), the 3RU11 overload relays for mounting onto contactor can also be installed as stand-alone units.

2) Observe maximum rated operational current of the devices.

3) Guide value for 4-pole standard motors at 50 Hz 400 V AC. The actual starting and rated data of the motor to be protected must be considered when selecting the units.

4) Maximum protection by fuse only for overload relays, type of coordination "2". Fuse values in connection with contactors see "Technical Specifications" → "Short-circuit protection with fuses/motor starter protectors for motor feeders" in "Reference Manual for Protection Equipment – 3RU1, 3RB2 Overload Relays".

5) For overload relays > 100 A see 3RB2 solid-state overload relays on page 7/50 onwards.

Overload Relays

SIRIUS 3RU1 Thermal Overload Relays





**3RU11 up to 100 A
for standard applications**

3RU11 thermal overload relays with screw terminals on the auxiliary current side for stand-alone installation¹⁾, CLASS 10

Features and technical specifications:

- Overload and phase failure protection
- Auxiliary contacts 1 NO + 1 NC
- Manual and automatic RESET

- Switch position indicator
- TEST function
- STOP button
- Integrated, sealable cover

Size of contactor ²⁾	Rating for induction motor P ³⁾	Current setting of the inverse-time delayed overload release	Short-circuit protection with fuse, type of coordination "2", gG operational class ⁴⁾	DT	Screw terminals (on auxiliary current side)	⊕	PU (UNIT, SET, M)	PS*	PG			
										Order No.	Price € per PU	
Size S00												
	S00	0,04	0,11 ... 0,16	0,5	▶	3RU11 16-0AB1		1	1 unit	41F		
		0,06	0,14 ... 0,2	1	▶	3RU11 16-0BB1		1	1 unit	41F		
		0,06	0,18 ... 0,25	1	▶	3RU11 16-0CB1		1	1 unit	41F		
		0,09	0,22 ... 0,32	1,6	▶	3RU11 16-0DB1		1	1 unit	41F		
	3RU11 16-0AB1		0,09	0,28 ... 0,4	2	▶	3RU11 16-0EB1		1	1 unit	41F	
			0,12	0,35 ... 0,5	2	▶	3RU11 16-0FB1		1	1 unit	41F	
			0,18	0,45 ... 0,63	2	▶	3RU11 16-0GB1		1	1 unit	41F	
			0,18	0,55 ... 0,8	4	▶	3RU11 16-0HB1		1	1 unit	41F	
				0,25	0,7 ... 1	4	▶	3RU11 16-0JB1		1	1 unit	41F
				0,37	0,9 ... 1,25	4	▶	3RU11 16-0KB1		1	1 unit	41F
				0,55	1,1 ... 1,6	6	▶	3RU11 16-1AB1		1	1 unit	41F
				0,75	1,4 ... 2	6	▶	3RU11 16-1BB1		1	1 unit	41F
			0,75	1,8 ... 2,5	10	▶	3RU11 16-1CB1		1	1 unit	41F	
			1,1	2,2 ... 3,2	10	▶	3RU11 16-1DB1		1	1 unit	41F	
			1,5	2,8 ... 4	16	▶	3RU11 16-1EB1		1	1 unit	41F	
			1,5	3,5 ... 5	20	▶	3RU11 16-1FB1		1	1 unit	41F	
			2,2	4,5 ... 6,3	20	▶	3RU11 16-1GB1		1	1 unit	41F	
			3	5,5 ... 8	25	▶	3RU11 16-1HB1		1	1 unit	41F	
			4	7 ... 10	35	▶	3RU11 16-1JB1		1	1 unit	41F	
			5,5	9 ... 12	35	▶	3RU11 16-1KB1		1	1 unit	41F	
Size S0												
	S0	7,5	11 ... 16	40	▶	3RU11 26-4AB1		1	1 unit	41F		
		7,5	14 ... 20	50	▶	3RU11 26-4BB1		1	1 unit	41F		
		11	17 ... 22	63	▶	3RU11 26-4CB1		1	1 unit	41F		
		11	20 ... 25	63	▶	3RU11 26-4DB1		1	1 unit	41F		
Size S2												
	S2	15	22 ... 32	80	▶	3RU11 36-4EB1		1	1 unit	41F		
		18,5	28 ... 40	80	▶	3RU11 36-4FB1		1	1 unit	41F		
		22	36 ... 45	100	▶	3RU11 36-4GB1		1	1 unit	41F		
		22	40 ... 50	100	▶	3RU11 36-4HB1		1	1 unit	41F		
Size S3												
	S3	30	45 ... 63	125	▶	3RU11 46-4JB1		1	1 unit	41F		
		37	57 ... 75	160	▶	3RU11 46-4KB1		1	1 unit	41F		
		45	70 ... 90	160	▶	3RU11 46-4LB1		1	1 unit	41F		
		45	80 ... 100 ⁵⁾	200	▶	3RU11 46-4MB1		1	1 unit	41F		

¹⁾ Sizes S00 to S3 for screw and snap-on mounting onto TH 35 standard mounting rails, size S3 also for TH 75 standard mounting rails.

²⁾ Observe maximum rated operational current of the devices.

³⁾ Guide value for 4-pole standard motors at 50 Hz 400 V AC. The actual starting and rated data of the motor to be protected must be considered when selecting the units.

⁴⁾ Maximum protection by fuse only for overload relays, type of coordination "2". Fuse values in connection with contactors see "Technical Specifications" → "Short-circuit protection with fuses/motor starter protectors for motor feeders" in "Reference Manual for Protection Equipment – 3RU1, 3RB2 Overload Relays".

⁵⁾ For overload relays > 100 A see 3RB2 solid-state overload relays on page 7/50 onwards.

Overload Relays

SIRIUS 3RU1 Thermal Overload Relays





3RU11 up to 100 A
for standard applications

3RU11 thermal overload relays with spring-type terminals for mounting onto contactor¹⁾, CLASS 10

Features and technical specifications:

- Overload and phase failure protection
- Auxiliary contacts 1 NO + 1 NC
- Manual and automatic RESET

- Switch position indicator
- TEST function
- STOP button
- Integrated, sealable cover

Size of contactor ²⁾	Rating for induction motor $P^{3)}$	Current setting of the inverse-time delayed overload release	Short-circuit protection with fuse, type of coordination "2", gG operational class ⁴⁾	DT	Spring-type terminals (on auxiliary current side)	PU (UNIT, SET, M)	PS*	PG			
									Order No.	Price € per PU	
Size S00 for stand-alone installation⁵⁾⁶⁾											
 3RU11 16-..C1	S00	0,04	0,11 ... 0,16	0,5	B	3RU11 16-0AC1	1	1 unit	41F		
		0,06	0,14 ... 0,2	1	B	3RU11 16-0BC1	1	1 unit	41F		
		0,06	0,18 ... 0,25	1	B	3RU11 16-0CC1	1	1 unit	41F		
		0,09	0,22 ... 0,32	1,6	B	3RU11 16-0DC1	1	1 unit	41F		
	S00	0,09	0,28 ... 0,4	2	B	3RU11 16-0EC1	1	1 unit	41F		
		0,12	0,35 ... 0,5	2	B	3RU11 16-0FC1	1	1 unit	41F		
		0,18	0,45 ... 0,63	2	▶	3RU11 16-0GC1	1	1 unit	41F		
		0,18	0,55 ... 0,8	4	▶	3RU11 16-0HC1	1	1 unit	41F		
		0,25	0,7 ... 1	4	▶	3RU11 16-0JC1	1	1 unit	41F		
		0,37	0,9 ... 1,25	4	▶	3RU11 16-0KC1	1	1 unit	41F		
		0,55	1,1 ... 1,6	6	▶	3RU11 16-1AC1	1	1 unit	41F		
		0,75	1,4 ... 2	6	▶	3RU11 16-1BC1	1	1 unit	41F		
	S00	0,75	1,8 ... 2,5	10	B	3RU11 16-1CC1	1	1 unit	41F		
		1,1	2,2 ... 3,2	10	▶	3RU11 16-1DC1	1	1 unit	41F		
		1,5	2,8 ... 4	16	B	3RU11 16-1EC1	1	1 unit	41F		
		1,5	3,5 ... 5	20	▶	3RU11 16-1FC1	1	1 unit	41F		
		2,2	4,5 ... 6,3	20	▶	3RU11 16-1GC1	1	1 unit	41F		
		3	5,5 ... 8	25	▶	3RU11 16-1HC1	1	1 unit	41F		
		4	7 ... 10	35	▶	3RU11 16-1JC1	1	1 unit	41F		
5,5		9 ... 12	35	▶	3RU11 16-1KC1	1	1 unit	41F			
Size S0¹⁾⁷⁾											
 3RU11 16-..D0	S0	0,75	1,8 ... 2,5	10	B	3RU11 26-1CD0	1	1 unit	41F		
		1,1	2,2 ... 3,2	10	B	3RU11 26-1DD0	1	1 unit	41F		
		1,5	2,8 ... 4	16	B	3RU11 26-1ED0	1	1 unit	41F		
		1,5	3,5 ... 5	20	B	3RU11 26-1FD0	1	1 unit	41F		
	S0	2,2	4,5 ... 6,3	20	B	3RU11 26-1GD0	1	1 unit	41F		
		3	5,5 ... 8	25	B	3RU11 26-1HD0	1	1 unit	41F		
		4	7 ... 10	35	B	3RU11 26-1JD0	1	1 unit	41F		
		5,5	9 ... 12,5	35	B	3RU11 26-1KD0	1	1 unit	41F		
		7,5	11 ... 16	40	▶	3RU11 26-4AD0	1	1 unit	41F		
		7,5	14 ... 20	50	▶	3RU11 26-4BD0	1	1 unit	41F		
		11	17 ... 22	63	▶	3RU11 26-4CD0	1	1 unit	41F		
		11	20 ... 25	63	▶	3RU11 26-4DD0	1	1 unit	41F		
		Size S2¹⁾⁷⁾									
 3RU11 36-..D0	S2	3	5,5 ... 8	25	B	3RU11 36-1HD0	1	1 unit	41F		
		4	7 ... 10	35	B	3RU11 36-1JD0	1	1 unit	41F		
		5,5	9 ... 12,5	35	B	3RU11 36-1KD0	1	1 unit	41F		
		7,5	11 ... 16	40	B	3RU11 36-4AD0	1	1 unit	41F		
	S2	7,5	14 ... 20	50	B	3RU11 36-4BD0	1	1 unit	41F		
		11	18 ... 25	63	B	3RU11 36-4DD0	1	1 unit	41F		
		15	22 ... 32	80	▶	3RU11 36-4ED0	1	1 unit	41F		
		18,5	28 ... 40	80	▶	3RU11 36-4FD0	1	1 unit	41F		
		22	36 ... 45	100	▶	3RU11 36-4GD0	1	1 unit	41F		
		22	40 ... 50	100	▶	3RU11 36-4HD0	1	1 unit	41F		
		Size S3¹⁾⁷⁾									
		 3RU11 46-..D0	S3	11	18 ... 25	63	B	3RU11 46-4DD0	1	1 unit	41F
				15	22 ... 32	80	B	3RU11 46-4ED0	1	1 unit	41F
18,5	28 ... 40			80	B	3RU11 46-4FD0	1	1 unit	41F		
22	36 ... 50			125	B	3RU11 46-4HD0	1	1 unit	41F		
S3	30		45 ... 63	125	▶	3RU11 46-4JD0	1	1 unit	41F		
	37		57 ... 75	160	▶	3RU11 46-4KD0	1	1 unit	41F		
	45		70 ... 90	160	▶	3RU11 46-4LD0	1	1 unit	41F		
	45		80 ... 100	200	▶	3RU11 46-4MD0	1	1 unit	41F		

1) With the suitable terminal brackets (see "Accessories" on page 7/46), the 3RU11 overload relays for mounting onto contactor can also be installed as stand-alone units.

2) Observe maximum rated operational current of the devices.

3) Guide value for 4-pole standard motors at 50 Hz 400 V AC. The actual starting and rated data of the motor to be protected must be considered when selecting the units.

4) Maximum protection by fuse only for overload relays, type of coordination "2". Fuse values in connection with contactors see "Technical Specifications" → "Short-circuit protection with fuses/motor starter protectors for motor feeders" in "Reference Manual for Protection Equipment – 3RU1, 3RB2 Overload Relays".

5) Size S00 for screw and snap-on mounting onto TH 35 standard mounting rail.

6) Auxiliary and main conductor connections with spring-type terminals.

7) Auxiliary conductor connections with spring-type terminals and main conductor connections with screw terminals.

Overload Relays

SIRIUS 3RU1 Thermal Overload Relays

Accessories

Overview





Overload relays for standard applications

The following optional accessories are available for the 3RU11 thermal overload relays:

- Terminal bracket for stand-alone installation of overload relay sizes S00 to S3
- Mechanical RESET (for all sizes)

- Cable release for resetting devices which are difficult to access (for all sizes)
- Electrical remote RESET module in three voltage variants (for all sizes)
- Terminal covers

Selection and ordering data



Version	Size	DT	Order No.	Price € per PU	PU (UNIT, SET, M)	PS*	PG	
Terminal brackets for stand-alone installation								
 <p>3RU19 .6-3AA01</p>	For separate mounting of overload relays; screw and snap-on mounting onto TH 35 standard mounting rail; size S3 also for TH 75 standard mounting rail	S00	▶ 3RU19 16-3AA01		1	1 unit	41F	
		S0	▶ 3RU19 26-3AA01		1	1 unit	41F	
		S2	▶ 3RU19 36-3AA01		1	1 unit	41F	
		S3	▶ 3RU19 46-3AA01		1	1 unit	41F	
Mechanical RESET								
 <p>3RU19 00-1A with pushbutton and extension plunger</p>	Resetting plungers, holders and formers	S00 ...S3	▶ 3RU19 00-1A		1	1 unit	41F	
	Pushbuttons with extended stroke (12 mm), IP65, Ø 22 mm	S00 ...S3	B	3SB30 00-0EA11		1	1 unit	41J
	Extension plungers For compensation of the distance between the pushbutton and the unlatching button of the relay	S00 ...S3	A	3SX1 335		1	1 unit	41J
Cable releases with holder for RESET								
 <p>3RU19 00-1.</p>	For Ø 6.5 mm holes in the control panel; max. control panel thickness 8 mm	S00 ...S3	▶ 3RU19 00-1B		1	1 unit	41F	
	• Length 400 mm • Length 600 mm	S00 ...S3	▶ 3RU19 00-1C		1	1 unit	41F	
Modules for remote RESET, electrical								
 <p>3RU19 00-2A.71</p>	Operating range 0.85 ... 1.1 × U_N , power consumption 80 VA AC, 70 W DC, ON period 0.2 ... 4 s, switching frequency 60/h	S00 ...S3	▶ 3RU19 00-2AB71		1	1 unit	41F	
	• 24 ... 30 V AC/DC	S00 ...S3	▶ 3RU19 00-2AF71		1	1 unit	41F	
	• 110 ... 127 V AC/DC • 220 ... 250 V AC/DC	S00 ...S3	▶ 3RU19 00-2AM71		1	1 unit	41F	
Terminal covers								
Covers for cable lugs and busbar connections								
• Length 55 mm	S3	▶ 3RT19 46-4EA1		1	1 unit	41B		
Covers for box terminals								
• Length 20.6 mm	S2	▶ 3RT19 36-4EA2		1	1 unit	41B		
• Length 20.8 mm	S3	▶ 3RT19 46-4EA2		1	1 unit	41B		

Overload Relays

SIRIUS 3RU1 Thermal Overload Relays

Accessories

General accessories

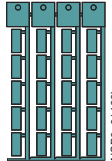
	Version	Size	Color	For over-load relays	DT	Order No.	Price € per PU	PU (UNIT, SET, M)	PS*	PG
Tools for opening spring-type terminals										
 8WA2 803	Screwdrivers	Length approx. 200 mm, 3.0 mm x 0.5 mm	Titanium gray/black, partially insulated	Main and auxiliary circuit connection: 3RU1	A	Spring-type terminals				
						3RA29 08-1A		1	1 unit	41B
Blank labels										
 3RT19 00-1SB20	Unit labeling plates¹⁾	20 mm x 7 mm	Pastel turquoise	3RU1	D	3RT19 00-1SB20		100	340 units	41B
	Inscription labels for sticking¹⁾	19 mm x 6 mm	Pastel turquoise	3RU1	C	3RT19 00-1SB60		100	3 060 units	41B
		19 mm x 6 mm	Zinc yellow			C	3RT19 00-1SD60		100	3 060 units

¹⁾ PC labeling system for individual inscription of unit labeling plates available from: murrplastik Systemtechnik GmbH (see Catalog IC 10 · 2012, Chapter 16, "Appendix" → "External Partners").

Overload Relays

SIRIUS 3RB2 Solid-State Overload Relays

3RB20, 3RB21 up to 630 A
for standard applications

Overview

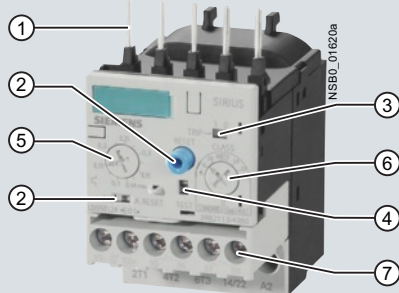

- ① Connection for mounting onto contactors:
Optimally adapted in electrical, mechanical and design terms to the contactors and soft starters. Connecting pins can be used for direct mounting of the overload relays. Stand-alone installation is possible as an alternative (in some cases in conjunction with a stand-alone installation module).
- ② Selector switch for manual/automatic RESET and RESET button:
With the slide switch you can choose between manual and automatic RESET. A device set to manual RESET can be reset locally by pressing the RESET button. On the 3RB21 a solid-state remote RESET is integrated.
- ③ Switch position indicator and TEST function of the wiring:
Indicates a trip and enables the wiring test.
- ④ Solid-state test (device test):
Enables a test of all important device components and functions.
- ⑤ Motor current setting:
Setting the device to the rated motor current is easy with the large rotary knob.
- ⑥ Trip class setting/internal ground-fault detection (only 3RB21):
Using the rotary switch you can set the required trip class and activate the internal ground-fault detection dependent on the start-up conditions.
- ⑦ Connecting terminals (removable joint block for auxiliary circuits):
The generously sized terminals permit connection of two conductors with different cross-sections for the main and auxiliary circuits. The auxiliary circuit can be connected with screw terminals and alternatively with spring-type terminals.

SIRIUS 3RB21 13-4RB0 solid-state overload relay

The 3RB20 and 3RB21 solid-state overload relays up to 630 A with internal power supply have been designed for inverse-time delayed protection of loads with normal and heavy starting ("Function" see "Reference Manual for Protection Equipment – 3RU1, 3RB2 Overload Relays") against excessive temperature rises due to overload, phase unbalance or phase failure.

An overload, phase unbalance or phase failure result in an increase of the motor current beyond the set rated motor current. This rise in current is detected by the current transformers integrated into the devices and evaluated by corresponding solid-state circuits which then output a pulse to the auxiliary contacts. The auxiliary contacts then switch off the load by means of a contactor. The break time depends on the ratio between the tripping current and current setting I_e and is stored in the form of a long-term stable tripping characteristic see www.siemens.com/sirius/support → "Characteristic Curves".

In addition to inverse-time delayed protection of loads against excessive temperature rises due to overload, phase unbalance and phase failure, the 3RB21 solid-state overload relays also allow internal ground-fault detection (not possible in conjunction with contactor assemblies for wye-delta starting). This provides protection of loads against high-resistance short circuits due to damage to the insulation material, moisture, condensed water etc.

The "tripped" status is signaled by means of a switch position indicator. Resetting takes place either manually or automatically after the recovery time has elapsed ("Function" see "Reference Manual for Protection Equipment – 3RU1, 3RB2 Overload Relays").

The devices are manufactured in accordance with environmental guidelines and contain environmentally-friendly and reusable materials. They comply with all important worldwide standards and approvals.

"Increased safety" type of protection EEx e according to ATEX directive 94/9/EC

The 3RB20/3RB21 solid-state overload relays are suitable for the overload protection of explosion-proof motors with "increased safety" type of protection EExe. The relays meet the requirements of EN 60079-7 (Electrical apparatus for areas subject to explosion hazards - Increased safety "e"); see www.siemens.com/sirius/atex.

EC type test certificate for Group II, Category (2) G/D exists. It has the number PTB 06 ATEX 3001.

Order No. scheme

Digit of the Order No.	1st - 3rd	4th	5th	6th	7th	8th	9th	10th	11th
	<input type="checkbox"/> <input type="checkbox"/> <input type="checkbox"/>	<input type="checkbox"/>	<input type="checkbox"/>	<input type="checkbox"/>	<input type="checkbox"/>	-	<input type="checkbox"/>	<input type="checkbox"/>	<input type="checkbox"/>
Solid-state overload relays	3 R B								
SIRIUS 2nd generation		2							
Device series			<input type="checkbox"/>						
Size, rated operational current and power				<input type="checkbox"/>					
Version of the automatic RESET, electrical remote RESET					<input type="checkbox"/>				
Trip class (CLASS)						<input type="checkbox"/>			
Setting range of the overload release							<input type="checkbox"/>		
Connection methods								<input type="checkbox"/>	
Installation type									<input type="checkbox"/>
Example	3 R B	2	0	3	6	-	1	Q	B 0

Note:

The Order No. scheme is presented here merely for information purposes and for better understanding of the logic behind the order numbers.

For your orders, please use the order numbers quote in the catalog in the Selection and ordering data.

Overload Relays

SIRIUS 3RB2 Solid-State Overload Relays

**3RB20, 3RB21 up to 630 A
for standard applications**

Benefits

The most important features and benefits of the 3RB20/3RB21 solid-state overload relays are listed in the overview table (see "General Data", page 7/37 onwards).

Application

Industries

The 3RB20 and 3RB21 solid-state overload relays are suitable for customers from all industries who want to guarantee optimum inverse-time delayed protection of their electrical loads (e. g. motors) under normal and heavy starting conditions (CLASS 5 to 30), minimize project completion times, inventories and power consumption, and optimize plant availability and maintenance management.

Application

The 3RB20 and 3RB21 solid-state overload relays have been designed for the protection of induction motors in sinusoidal 50/60 Hz voltage networks. The relays are not suitable for the protection of single-phase AC or DC loads.

The 3RU11 thermal overload relays or the 3RB22 to 3RB24 solid-state overload relays can be used for single-phase AC loads. For DC loads we recommend the 3RU11 thermal overload relay.

Ambient conditions

The devices are insensitive to external influences such as shocks, corrosive ambient conditions, ageing and temperature fluctuations.

For the temperature range from -25 °C to $+60\text{ °C}$, the 3RB20 and 3RB21 solid-state overload relays compensate the temperature in accordance with IEC 60947-4-1.

For the 3RB20 and 3RB21 solid-state overload relays with the sizes S6, S10 and S12, the upper set value of the setting range must be reduced for ambient temperatures $> 50\text{ °C}$ by a certain factor.

Type	Setting range	Derating factor for the upper set value for stand-alone installation at ambient temperature	
		+50 °C	+60 °C
3RB20 56, 3RB21 56	50 ... 200 A	100 %	100 %
3RB20 66, 3RB21 66	55 ... 250 A	100 %	100 %
3RB20 66, 3RB21 66	160 ... 630 A	100 %	90 %

Type	Setting range	Derating factor for the upper set value for mounting onto contactor at ambient temperature	
		+50 °C	+60 °C
3RB20 56, 3RB21 56	50 ... 200 A	100 %	70 %
3RB20 66, 3RB21 66	55 ... 250 A	100 %	70 %
3RB20 66, 3RB21 66	160 ... 630 A	100 %	70 %

Overload Relays

SIRIUS 3RB2 Solid-State Overload Relays

3RB20, 3RB21 up to 630 A
for standard applications

Selection and ordering data

3RB20 solid-state overload relays for mounting onto contactor¹⁾²⁾ and stand-alone installation²⁾³⁾, CLASS 10

Features and technical specifications:

- Overload protection, phase failure protection and unbalance protection
- Internal power supply
- Auxiliary contacts 1 NO + 1 NC
- Manual and automatic RESET

- Switch position indicator
- TEST function and self-monitoring

PU (UNIT, SET, M) = 1
PS* = 1 unit
PG = 41G



Size of contactor ⁴⁾	Rating for induction motor P ⁵⁾	Current setting of the inverse-time delayed overload release	Short-circuit protection with fuse, type of coordination "2", gG operational class ⁶⁾	DT	Screw terminals (on auxiliary current side)		Spring-type terminals (on auxiliary current side)	
					Order No.	Price € per PU	Order No.	Price € per PU
Size S00¹⁾								
S00	0,04 ... 0,09	0,1 ... 0,4	1	▶	3RB20 16-1RB0		▶	3RB20 16-1RD0
	0,12 ... 0,37	0,32 ... 1,25	2	▶	3RB20 16-1NB0	A	▶	3RB20 16-1ND0
	0,55 ... 1,5	1 ... 4	10	▶	3RB20 16-1PB0	A	▶	3RB20 16-1PD0
	1,1 ... 5,5	3 ... 12	20	▶	3RB20 16-1SB0	A	▶	3RB20 16-1SD0
Size S0¹⁾								
S0	0,04 ... 0,09	0,1 ... 0,4	1	▶	3RB20 26-1RB0		▶	3RB20 26-1RD0
	0,12 ... 0,37	0,32 ... 1,25	2	▶	3RB20 26-1NB0		▶	3RB20 26-1ND0
	0,55 ... 1,5	1 ... 4	10	▶	3RB20 26-1PB0		▶	3RB20 26-1PD0
	1,1 ... 5,5	3 ... 12	20	▶	3RB20 26-1SB0	A	▶	3RB20 26-1SD0
	3 ... 11	6 ... 25	35	▶	3RB20 26-1QB0	A	▶	3RB20 26-1QD0
Size S2¹⁾³⁾⁷⁾								
S2	3 ... 11	6 ... 25	63	▶	3RB20 36-1QB0		▶	3RB20 36-1QD0
				▶	3RB20 36-1QW1		▶	3RB20 36-1QX1
	7,5 ... 22	12,5 ... 50	80	▶	3RB20 36-1UB0	A	▶	3RB20 36-1UD0
			▶	3RB20 36-1UW1		▶	3RB20 36-1UX1	
Size S3¹⁾³⁾⁷⁾								
S3	7,5 ... 22	12,5 ... 50	160	▶	3RB20 46-1UB0	A	▶	3RB20 46-1UD0
	11 ... 45	25 ... 100	315	▶	3RB20 46-1EB0	A	▶	3RB20 46-1ED0
				▶	3RB20 46-1EW1		▶	3RB20 46-1EX1
Size S6²⁾⁷⁾								
S6 with bus-bar connection	22 ... 90	50 ... 200	315	▶	3RB20 56-1FC2	A	▶	3RB20 56-1FF2
				▶	3RB20 56-1FW2		▶	3RB20 56-1FX2
For mounting to S6 contactors with box terminals								
Size S10/S12²⁾								
S10/S12 and size 14 (3TF68/3TF69)	22 ... 110	55 ... 250	400	▶	3RB20 66-1GC2		▶	3RB20 66-1GF2
	90 ... 450	160 ... 630	800	▶	3RB20 66-1MC2		▶	3RB20 66-1MF2

¹⁾ The relays with an Order No. ending with "0" are designed for mounting onto contactor. With the matching terminal brackets (see "Accessories", page 7/53) the sizes S00 and S0 can also be installed as stand-alone units.

²⁾ The relays with an Order No. ending with "2" are designed for mounting onto contactor and stand-alone installation. For 3TF68/3TF69 contactors, direct mounting is not possible.

³⁾ The relays with an Order No. ending with "1" are designed for stand-alone installation.

⁴⁾ Observe maximum rated operational current of the devices.

⁵⁾ Guide value for 4-pole standard motors at 50 Hz 400 V AC. The actual starting and rated data of the motor to be protected must be considered when selecting the units.

⁶⁾ Maximum protection by fuse only for overload relays, type of coordination "2". Fuse values in connection with contactors see "Technical Specifications" → "Short-Circuit Protection with Fuses for Motor Feeders" in "Reference Manual for Protection Equipment – 3RU1, 3RB2 Overload Relays".

⁷⁾ The relays with an Order No. with "W" or "X" in penultimate position are equipped with a straight-through transformer.

Overload Relays

SIRIUS 3RB2 Solid-State Overload Relays

**3RB20, 3RB21 up to 630 A
for standard applications**

3RB20 solid-state overload relays for mounting onto contactor¹⁾²⁾ and stand-alone installation²⁾³⁾, CLASS 20

Features and technical specifications:

- Overload protection, phase failure protection and unbalance protection
- Internal power supply
- Auxiliary contacts 1 NO + 1 NC
- Manual and automatic RESET

- Switch position indicator
- TEST function and self-monitoring

PU (UNIT, SET, M) = 1
PS* = 1 unit
PG = 41G



3RB20 16-2RB0



3RB20 26-2QD0



3RB20 36-2UB0





3RB20 46-2ED0



3RB20 56-2FW2



3RB20 66-2MF2

Size of contactor ⁴⁾	Rating for induction motor P ⁵⁾	Current setting of the inverse-time delayed overload release	Short-circuit protection with fuse, type of coordination "2", gG operational class ⁶⁾	DT	Screw terminals (on auxiliary current side) 		DT	Spring-type terminals (on auxiliary current side) 	
					Order No.	Price € per PU		Order No.	Price € per PU
Size S00¹⁾									
S00	0,04 ... 0,09	0,1 ... 0,4	1	▶	3RB20 16-2RB0		▶	3RB20 16-2RD0	
	0,12 ... 0,37	0,32 ... 1,25	2	▶	3RB20 16-2NB0		▶	3RB20 16-2ND0	
	0,55 ... 1,5	1 ... 4	10	▶	3RB20 16-2PB0		▶	3RB20 16-2PD0	
	1,1 ... 5,5	3 ... 12	20	▶	3RB20 16-2SB0		▶	3RB20 16-2SD0	
Size S0¹⁾									
S0	0,04 ... 0,09	0,1 ... 0,4	1	▶	3RB20 26-2RB0		▶	3RB20 26-2RD0	
	0,12 ... 0,37	0,32 ... 1,25	2	▶	3RB20 26-2NB0		▶	3RB20 26-2ND0	
	0,55 ... 1,5	1 ... 4	10	▶	3RB20 26-2PB0		▶	3RB20 26-2PD0	
	1,1 ... 5,5	3 ... 12	20	▶	3RB20 26-2SB0	A	▶	3RB20 26-2SD0	
	3 ... 11	6 ... 25	35	▶	3RB20 26-2QB0	A	▶	3RB20 26-2QD0	
Size S2¹⁾³⁾⁷⁾									
S2	3 ... 11	6 ... 25	63	▶	3RB20 36-2QB0		▶	3RB20 36-2QD0	
				▶	3RB20 36-2QW1		▶	3RB20 36-2QX1	
	7,5 ... 22	12,5 ... 50	80	▶	3RB20 36-2UB0		▶	3RB20 36-2UD0	
				▶	3RB20 36-2UW1		▶	3RB20 36-2UX1	
Size S3¹⁾³⁾⁷⁾									
S3	7,5 ... 22	12,5 ... 50	160	▶	3RB20 46-2UB0	A	▶	3RB20 46-2UD0	
	11 ... 45	25 ... 100	315	▶	3RB20 46-2EB0	A	▶	3RB20 46-2ED0	
				▶	3RB20 46-2EW1		▶	3RB20 46-2EX1	
Size S6²⁾⁷⁾									
S6 with busbar connections	22 ... 90	50 ... 200	315	▶	3RB20 56-2FC2	A	▶	3RB20 56-2FF2	
For mounting to S6 contactors with box terminals				▶	3RB20 56-2FW2		▶	3RB20 56-2FX2	
Size S10/S12²⁾									
S10/S12 and size 14 (3TF68/3TF69)	22 ... 110	55 ... 250	400	▶	3RB20 66-2GC2		▶	3RB20 66-2GF2	
	90 ... 450	160 ... 630	800	▶	3RB20 66-2MC2		▶	3RB20 66-2MF2	

1) The relays with an Order No. ending with "0" are designed for mounting onto contactor. With the matching terminal brackets (see "Accessories", page 7/53) the sizes S00 and S0 can also be installed as stand-alone units.

2) The relays with an Order No. ending with "2" are designed for mounting onto contactor and stand-alone installation. For 3TF68/3TF69 contactors, direct mounting is not possible.

3) The relays with an Order No. ending with "1" are designed for stand-alone installation.

4) Observe maximum rated operational current of the devices.

5) Guide value for 4-pole standard motors at 50 Hz 400 V AC. The actual starting and rated data of the motor to be protected must be considered when selecting the units.

6) Maximum protection by fuse only for overload relays, type of coordination "2". Fuse values in connection with contactors see "Technical Specifications" → "Short-Circuit Protection with Fuses for Motor Feeders" in "Reference Manual for Protection Equipment – 3RU1, 3RB2 Overload Relays".

7) The relays with an Order No. with "W" or "X" in penultimate position are equipped with a straight-through transformer.

Overload Relays

SIRIUS 3RB2 Solid-State Overload Relays

**3RB20, 3RB21 up to 630 A
for standard applications**

**3RB21 solid-state overload relays for mounting onto contactor¹⁾²⁾ and stand-alone installation²⁾³⁾,
CLASS 5, 10, 20 and 30 adjustable**

Features and technical specifications:

- Overload protection, phase failure protection and unbalance protection
- Internal ground-fault detection (activatable)
- Internal power supply
- Auxiliary contacts 1 NO + 1 NC
- Manual and automatic RESET
- Electrical remote RESET integrated

- Switch position indicator
- TEST function and self-monitoring

PU (UNIT, SET, M) = 1
PS* = 1 unit
PG = 41G



3RB21 13-4RB0



3RB21 23-4QD0



3RB21 33-4UB0



3RB21 43-4ED0



3RB21 53-4FX2



3RB21 63-4MC2

Size of contactor ⁴⁾	Rating for induction motor P ⁵⁾	Current setting of the inverse-time delayed overload release	Short-circuit protection with fuse, type of coordination "2", gG operational class ⁶⁾	DT	Screw terminals (on auxiliary current side)	DT	Spring-type terminals (on auxiliary current side)	
	kW	A	A		Order No.	Price € per PU	Order No.	Price € per PU
Size S00¹⁾								
S00	0,04 ... 0,09	0,1 ... 0,4	1	▶	3RB21 13-4RB0		3RB21 13-4RD0	
	0,12 ... 0,37	0,32 ... 1,25	2	▶	3RB21 13-4NB0		3RB21 13-4ND0	
	0,55 ... 1,5	1 ... 4	10	▶	3RB21 13-4PB0		3RB21 13-4PD0	
	1,1 ... 5,5	3 ... 12	20	▶	3RB21 13-4SB0		3RB21 13-4SD0	
Size S0¹⁾								
S0	0,04 ... 0,09	0,1 ... 0,4	1	▶	3RB21 23-4RB0		3RB21 23-4RD0	
	0,12 ... 0,37	0,32 ... 1,25	2	▶	3RB21 23-4NB0		3RB21 23-4ND0	
	0,55 ... 1,5	1 ... 4	10	▶	3RB21 23-4PB0		3RB21 23-4PD0	
	1,1 ... 5,5	3 ... 12	20	▶	3RB21 23-4SB0	A	3RB21 23-4SD0	
	3 ... 11	6 ... 25	35	▶	3RB21 23-4QB0	A	3RB21 23-4QD0	
Size S2¹⁾³⁾⁷⁾								
S2	3 ... 11	6 ... 25	63	▶	3RB21 33-4QB0		3RB21 33-4QD0	
	7,5 ... 22	12,5 ... 50	80	▶	3RB21 33-4QW1		3RB21 33-4QX1	
				▶	3RB21 33-4UB0		3RB21 33-4UD0	
			▶	3RB21 33-4UW1		3RB21 33-4UX1		
Size S3¹⁾³⁾⁷⁾								
S3	7,5 ... 22	12,5 ... 50	160	▶	3RB21 43-4UB0		3RB21 43-4UD0	
	11 ... 45	25 ... 100	315	▶	3RB21 43-4EB0		3RB21 43-4ED0	
				▶	3RB21 43-4EW1		3RB21 43-4EX1	
Size S6²⁾⁷⁾								
S6 with busbar connections	22 ... 90	50 ... 200	315	▶	3RB21 53-4FC2		3RB21 53-4FF2	
				▶	3RB21 53-4FW2		3RB21 53-4FX2	
Size S10/S12²⁾								
S10/S12 and size 14 (3TF68/3TF69)	22 ... 110	55 ... 250	400	▶	3RB21 63-4GC2		3RB21 63-4GF2	
	90 ... 450	160 ... 630	800	▶	3RB21 63-4MC2		3RB21 63-4MF2	

¹⁾ The relays with an Order No. ending with "0" are designed for mounting onto contactor. With the matching terminal brackets (see "Accessories", page 7/53) the sizes S00 and S0 can also be installed as stand-alone units.

²⁾ The relays with an Order No. ending with "2" are designed for mounting onto contactor and stand-alone installation. For 3TF68/3TF69 contactors, direct mounting is not possible.

³⁾ The relays with an Order No. ending with "1" are designed for stand-alone installation.

⁴⁾ Observe maximum rated operational current of the devices.

⁵⁾ Guide value for 4-pole standard motors at 50 Hz 400 V AC. The actual starting and rated data of the motor to be protected must be considered when selecting the units.

⁶⁾ Maximum protection by fuse only for overload relays, type of coordination "2". Fuse values in connection with contactors see "Technical Specifications" → "Short-Circuit Protection with Fuses for Motor Feeders" in "Reference Manual for Protection Equipment – 3RU1, 3RB2 Overload Relays".

⁷⁾ The relays with an Order No. with "W" or "X" in penultimate position are equipped with a straight-through transformer.

Overload Relays

SIRIUS 3RB2 Solid-State Overload Relays

Accessories for 3RB20, 3RB21



Overview

Overload relays for standard applications

The following optional accessories are available for the 3RB20 and 3RB21 solid-state overload relays:

- Mechanical RESET (for all sizes)
- Cable release for resetting devices which are difficult to access (for all sizes)
- Sealable cover (for all sizes)
- Terminal covers for sizes S2 to S10/S12
- Box terminal blocks for sizes S6 and S10/S12





Selection and ordering data

Version	Size	DT	Order No.	Price € per PU	PU (UNIT, SET, M)	PS*	PG
Terminal brackets for stand-alone installation							
	For separate mounting of the overload relays; screw and snap-on mounting onto TH 35 standard mounting rail	S00	▶ 3RB29 13-0AA1		1	1 unit	41F
		S0	▶ 3RB29 23-0AA1		1	1 unit	41F
3RB29 .3-0AA1							
Mechanical RESET							
	Resetting plungers, holders and formers	S00 ... S10/S12	▶ 3RU19 00-1A		1	1 unit	41F
	Pushbuttons with extended stroke (12 mm), IP65, ∅ 22 mm	S00 ... S10/S12	B 3SB30 00-0EA11		1	1 unit	41J
	Extension plungers For compensation of the distance between a pushbutton and the unlatching button of the relay	S00 ... S10/S12	A 3SX1 335		1	1 unit	41J
3RU19 00-1A with pushbutton and extension plunger							
Cable releases with holder for RESET							
	For ∅ 6.5 mm holes in the control panel; max. control panel thickness 8 mm	S00 ... S10/S12					
	<ul style="list-style-type: none"> • Length 400 mm • Length 600 mm 		▶ 3RU19 00-1B		1	1 unit	41F
			▶ 3RU19 00-1C		1	1 unit	41F
3RU19 00-1.							

Overload Relays

SIRIUS 3RB2 Solid-State Overload Relays

Accessories for 3RB20, 3RB21

Version	Size	DT	Order No.	Price € per PU	PU (UNIT, SET, M)	PS*	PG
Sealable covers							
 3RB29 84-0	For covering the setting knobs	S00 ... S10/S12	▶ 3RB29 84-0		1	10 units	41F
Terminal covers							
Covers for cable lugs and busbar connections							
 3RT19 46-4EA1	• Length 55 mm	S3	▶ 3RT19 46-4EA1		1	1 unit	41B
	• Length 100 mm	S6	▶ 3RT19 56-4EA1		1	1 unit	41B
	• Length 120 mm	S10/S12	▶ 3RT19 66-4EA1		1	1 unit	41B
Covers for box terminals							
 3RT19 36-4EA2	• Length 20.6 mm	S2	▶ 3RT19 36-4EA2		1	1 unit	41B
	• Length 20.8 mm	S3	▶ 3RT19 46-4EA2		1	1 unit	41B
	• Length 25 mm	S6	▶ 3RT19 56-4EA2		1	1 unit	41B
	• Length 30 mm	S10/S12	▶ 3RT19 66-4EA2		1	1 unit	41B
Covers for screw terminals							
The figures show mounting on the contactor.	between contactor and overload relay, without box terminals	S6	▶ 3RT19 56-4EA3		1	1 unit	41B
	(1 unit required per combination)	S10/S12	▶ 3RT19 66-4EA3		1	1 unit	41B
Box terminal blocks							
 3RT19 5.-4G	For round and ribbon cables						
	• Up to 70 mm ²	S6 ¹⁾	▶ 3RT19 55-4G		1	1 unit	41B
	• Up to 120 mm ²	S6	▶ 3RT19 56-4G		1	1 unit	41B
	• Up to 240 mm ²	S10/S12	▶ 3RT19 66-4G		1	1 unit	41B
	Technical specifications for conductor cross-sections see "Reference Manual for Protection Equipment – 3RU1, 3RB2 Overload Relays".						

¹⁾ In the scope of supply for 3RT10 54-1 contactors (55 kW).

General accessories

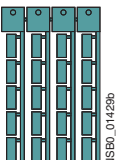
Version	Size	Color	For over-load relays	DT	Order No.	Price € per PU	PU (UNIT, SET, M)	PS*	PG
Tools for opening spring-type terminals									
 3RA29 08-1A	Screwdrivers For all SIRIUS devices with spring-type terminals	Length approx. 200 mm, 3.0 mm x 0.5 mm	Titanium gray/black, partially insulated	Main and auxiliary circuit connection: 3RB2	A				
					Spring-type terminals 3RA29 08-1A		1	1 unit	41B
Blank labels									
 3RT19 00-1SB20	Unit labeling plates ¹⁾ for SIRIUS devices	20 mm x 7 mm	Pastel turquoise	3RB2	D	3RT19 00-1SB20	100	340 units	41B
	Inscription labels for sticking ¹⁾ For SIRIUS devices	19 mm x 6 mm	Pastel turquoise	3RB2	C	3RT19 00-1SB60	100	3 060 units	41B
		19 mm x 6 mm	Zinc yellow		C	3RT19 00-1SD60	100	3 060 units	41B

¹⁾ PC labeling system for individual inscription of unit labeling plates available from: murrplastik Systemtechnik GmbH (see Catalog IC 10 · 2012, Chapter 16, "Appendix" → "External Partners").

Overload Relays

SIRIUS 3RB2 Solid-State Overload Relays

3RB22, 3RB23 up to 630 A
for High-Feature applications

Overview

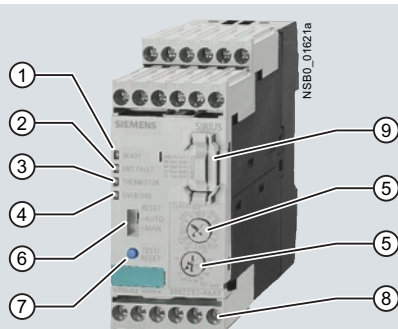

- ① Green LED "READY":
A continuous green light signals that the device is working correctly.
- ② Red LED "GND FAULT":
A continuous red light signals a ground-fault tripping.
- ③ Red LED "THERMISTOR":
A continuous red light signals an active thermistor trip.
- ④ Red LED "OVERLOAD":
A continuous red light signals an active overload trip; a flickering red light signals an imminent trip (overload warning).
- ⑤ Motor current and trip class setting:
Setting the device to the motor current and to the required trip class dependent on the start-up conditions is easy with the two rotary switches.
- ⑥ Selector switch for manual/automatic RESET:
With this switch you can choose between manual and automatic RESET.
- ⑦ Test/RESET button:
Enables testing of all important device components and functions, plus resetting of the device after a trip when manual RESET is selected.
- ⑧ Connecting terminals (removable joint block):
The generously sized terminals permit connection of two conductors with different cross-sections for the auxiliary, control and sensor circuits. Connection is possible with screw connection and alternatively with spring-type connection.
- ⑨ 3RB29 85 function expansion module:
Enables more functions to be added, e. g. internal ground-fault detection and/or an analog output with corresponding signals.

SIRIUS 3RB22 and 3RB23 evaluation modules

The 3RB22 and 3RB23 solid-state overload relays up to 630 A (up to 820 A possible with a series transformer) have a modular structure and consist of an evaluation unit, a current measuring module and a connecting cable. The overload relays type 3RB22 (with monostable auxiliary contacts) and type 3RB23 (with bistable auxiliary contacts) are supplied from an external power supply.

They have been designed for inverse-time delayed protection of loads with normal and heavy starting ("Function" see [Reference Manual for Protection Equipment – 3RU1, 3RB2 Overload Relays](#)) against excessive temperature rises due to overload, phase unbalance or phase failure. An overload, phase unbalance or phase failure result in an increase of the motor current beyond the set rated motor current.

This current rise is detected by means of a current measuring module (see [page 7/60](#)) and electronically evaluated by the evaluation module which is connected to it. The evaluation electronics sends a signal to the auxiliary contacts. The auxiliary contacts then switch off the load by means of a contactor. The break time depends on the ratio between the tripping current and current setting I_e and is stored in the form of a long-term stable tripping characteristic see www.siemens.com/sirius/support → "Characteristic Curves". The "tripped" status is signaled by means of a continuous red "OVERLOAD" LED.

The LED indicates imminent tripping of the relay due to overload, phase unbalance or phase failure by flickering when the current limit has been exceeded. This alarm is also issued as a signal through auxiliary contacts for the 3RB22 and 3RB23 overload relays.

In addition to the described inverse-time delayed protection of loads against excessive temperature rises, the 3RB22/3RB23 solid-state overload relays also allow direct temperature monitoring of the motor windings (full motor protection) by connection with broken-wire interlock of a PTC sensor circuit. With this temperature-dependent protection, the loads can be protected against overheating caused indirectly by reduced coolant flow, for example, which cannot be detected by means of the current alone. In the event of overtemperature, the devices switch off the contactor, and thus the load, by means of the auxiliary contacts. The "tripped" status is signaled by means of a continuously illuminated "THERMISTOR" LED.

Due to protect the loads against high-resistance short circuits due to damage to the insulation, humidity, condensed water, etc., the 3RB22 and 3RB23 solid-state overload relays offer the possibility of internal ground fault monitoring in conjunction with a function expansion module (for details see ["Selection and Ordering Data"](#), not possible in conjunction with contactor assembly for Wye-Delta starting). In the event of a ground fault the 3RB22/3RB23 relays trip instantaneously. The "tripped" status is signaled by means of a continuous red "Ground Fault" LED. Signaling through auxiliary contacts is also possible.

After tripping due to overload, phase unbalance, phase failure, thermistor or ground-fault tripping, the relay is reset manually or automatically after the recovery time has elapsed ("Function" see ["Reference Manual for Protection Equipment – 3RU1, 3RB2 Overload Relays"](#)). In conjunction with a function expansion module the motor current measured by the microprocessor can be output in the form of an analog signal DC 4 mA to 20 mA for operating rotary coil instruments or for feeding into analog inputs of programmable logic controllers.

With an additional AS-Interface analog module, the current values can also be transferred over the AS-i bus system.

The devices are manufactured in accordance with environmental guidelines and contain environmentally-friendly and reusable materials.

They comply with all important worldwide standards and approvals.

Type of protection "increased safety EEx e and explosion-proof enclosure EEx d" in accordance with ATEX Directive 94/9/EC

The 3RB22 (monostable) solid-state overload relays protect motors of types of protection EEx e and EEx d in potentially explosive areas quickly and reliably.

They comply with the requirements of EN 60079-7 (Electrical apparatus for areas subject to explosion hazards - Increased safety "e" as well as for flameproof enclosure "d"); see www.siemens.com/sirius/atex.

EC prototype test certificate for Group II, Category (2) G/D exists. It has the number PTB 05 ATEX 3022.

Overload Relays

SIRIUS 3RB2 Solid-State Overload Relays

**3RB22, 3RB23 up to 630 A
for High-Feature applications**

Order No. scheme

Digit of the Order No.	1st - 3rd	4th	5th	6th	7th	8th	9th	10th	11th	
	<input type="checkbox"/> <input type="checkbox"/> <input type="checkbox"/>	<input type="checkbox"/>	<input type="checkbox"/>	<input type="checkbox"/>	<input type="checkbox"/>	-	<input type="checkbox"/>	<input type="checkbox"/>	<input type="checkbox"/>	<input type="checkbox"/>
Solid-state overload relays	3 R B									
SIRIUS 2nd generation		2								
Device series			<input type="checkbox"/>							
Size, rated operational current and power				<input type="checkbox"/>						
Version of the automatic RESET, electrical remote RESET					<input type="checkbox"/>					
Trip class (CLASS)						<input type="checkbox"/>				
Setting range of the overload release							<input type="checkbox"/>			
Connection methods								<input type="checkbox"/>		
Installation type									<input type="checkbox"/>	
Example	3 R B	2	2	8	3	-	4	A	A	1

Note:

The Order No. scheme is presented here merely for information purposes and for better understanding of the logic behind the order numbers.

For your orders, please use the order numbers quote in the catalog in the Selection and ordering data.

Benefits

The most important features and benefits of the 3RB22 and 3RB23 solid-state overload relays are listed in the overview table (see "General Data", page 7/37 onwards).

Advantages through energy efficiency

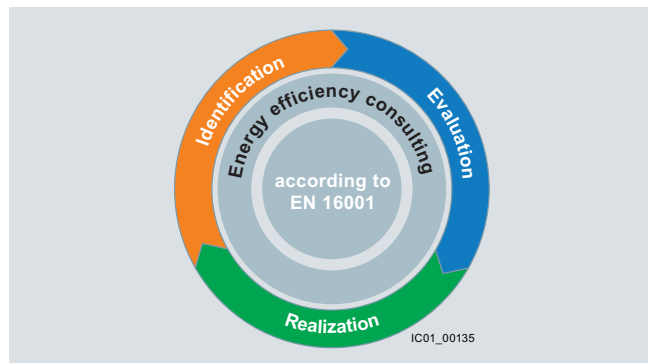

Overview of the energy management process

We offer you a unique portfolio for efficient energy management in the industry – a process that is used to optimize the energy requirements. We divide operational energy management into the three phases: identification, evaluation and implementation, and support you with suitable hardware and software solutions in each phase of the process.

The innovative products of the SIRIUS industrial controls portfolio can also make a substantial contribution to a plant's energy efficiency (see www.siemens.de/sirius/energiesparen).

3RB22 and 3RB23 solid-state overload relays contribute to energy efficiency throughout the plant as follows:

- Reduced inherent power loss
- Less heating of the control cabinet
- Smaller control cabinet air conditioners can be used

Application

Industries

The 3RB22 and 3RB23 solid-state overload relays are suitable for customers from all industries who want to guarantee optimum inverse-time delayed and temperature-dependent protection of their electrical loads (e. g. motors) under normal and heavy starting conditions (CLASS 5 to 30), minimize project completion times, inventories and power consumption, and optimize plant availability and maintenance management.

Application

The 3RB22 and 3RB23 devices have been designed for the protection of three-phase asynchronous and single-phase AC motors.

If single-phase AC motors are to be protected by the 3RB22 and 3RB23 solid-state overload relays, the main current paths of the current measuring modules must be series-connected ("Schematics" see "Reference Manual for Protection Equipment – 3RU1, 3RB2 Overload Relays").

Ambient conditions

The devices are insensitive to external influences such as shocks, corrosive ambient conditions, ageing and temperature fluctuations.

For the temperature range from –25 °C to +60 °C, the 3RB22 and 3RB23 solid-state overload relays compensate the temperature in accordance with IEC 60947-4-1.

Configuration notes for use of the devices below –25 °C or above +60 °C on request.

Overload Relays

SIRIUS 3RB2 Solid-State Overload Relays

3RB22, 3RB23 up to 630 A
for High-Feature applications

Selection and ordering data

3RB22 and 3RB23 solid-state overload relays (evaluation modules) for full motor protection, stand-alone installation, CLASS 5, 10, 20 and 30, adjustable

Type	3RB22 83-4A.1, 3RB23 83-4A.1
Features and technical specifications	
Overload protection, phase failure protection and unbalance protection	✓
Supplied from an external voltage	✓ 24 ... 240 V AC/DC
Auxiliary contacts	✓ 2 NO + 2 NC
Electrical remote RESET integrated	✓
4 LEDs for operating and status displays	✓
TEST function and self-monitoring	✓
Internal ground-fault detection	✓ (with function expansion module)
Screw or spring-type terminals for auxiliary, control and sensor circuits	✓
Input for PTC sensor circuit	✓
Analog output	✓ (with function expansion module)

✓ Available



PU (UNIT, SET, M) = 1
PS* = 1 unit
PG = 41G



3RB22 83-4AA1,
3RB23 83-4AA1



3RB22 83-4AC1,
3RB23 83-4AC1

Size of contactor	Version	DT	Screw terminals 		Spring-type terminals 	
			Order No.	Price € per PU	Order No.	Price € per PU
Evaluation modules						
S00 ... S12	Monostable	▶	3RB22 83-4AA1		3RB22 83-4AC1	
	Bistable	▶	3RB23 83-4AA1		3RB23 83-4AC1	

Note:

Overload relays overview – matching contactors [see page 7/40](#).

Current measuring modules and related connecting cables [see page 7/60](#), general accessories [see page 7/61](#).

Overload Relays

SIRIUS 3RB2 Solid-State Overload Relays

**3RB22, 3RB23 up to 630 A
for High-Feature applications**

Functions of the 3RB22 and 3RB23 evaluation modules in combination with the 3RB29 85 function expansion modules.

Evaluation modules	With function expansion module	Basic functions	Inputs		
			A1/A2	T1/T2	Y1/Y2
3RB22 83-4AA1 3RB22 83-4AC1 3RB23 83-4AA1 3RB23 83-4AC1	--	Inverse-time delayed protection, temperature-dependent protection, electrical remote RESET, overload warning	Power supply 24 ... 240 V AC/DC	Connection for PTC sensor	Electrical remote RESET
	3RB29 85-2CA1	Inverse-time delayed protection, temperature-dependent protection, internal ground-fault detection, electrical remote RESET, overload warning	Power supply 24 ... 240 V AC/DC	Connection for PTC sensor	Electrical remote RESET
	3RB29 85-2CB1	Inverse-time delayed protection, temperature-dependent protection, internal ground-fault detection, electrical remote RESET, ground-fault signal	Power supply 24 ... 240 V AC/DC	Connection for PTC sensor	Electrical remote RESET
	3RB29 85-2AA0	Inverse-time delayed protection, temperature-dependent protection, electrical remote RESET, overload warning, analog output	Power supply 24 ... 240 V AC/DC	Connection for PTC sensor	Electrical remote RESET
	3RB29 85-2AA1	Inverse-time delayed protection, temperature-dependent protection, internal ground-fault detection, electrical remote RESET, overload warning, analog output	Power supply 24 ... 240 V AC/DC	Connection for PTC sensor	Electrical remote RESET
	3RB29 85-2AB1	Inverse-time delayed protection, temperature-dependent protection, internal ground-fault detection, electrical remote RESET, ground-fault signal, analog output	Power supply 24 ... 240 V AC/DC	Connection for PTC sensor	Electrical remote RESET

Evaluation modules	With function expansion module	Outputs I (-) / I (+)	Outputs			
			95/96 NC	97/98 NO	05/06 NC	07/08 NO
3RB22 83-4AA1 3RB22 83-4AC1 3RB23 83-4AA1 3RB23 83-4AC1	--	No	Disconnection of the contactor (inverse-time delayed/temperature-dependent protection)	Signal "tripped"	Overload warning	Overload warning
	3RB29 85-2CA1	No	Disconnection of the contactor (inverse-time delayed/temperature-dependent protection + ground fault)	Signal "tripped"	Overload warning	Overload warning
	3RB29 85-2CB1	No	Disconnection of the contactor (inverse-time delayed/temperature-dependent protection)	Signal "tripped"	Disconnection of the contactor (ground fault)	Signal "ground-fault tripping"
	3RB29 85-2AA0	Analog signal	Disconnection of the contactor (inverse-time delayed/temperature-dependent protection)	Signal "tripped"	Overload warning	Overload warning
	3RB29 85-2AA1	Analog signal	Disconnection of the contactor (inverse-time delayed/temperature-dependent protection + ground fault)	Signal "tripped"	Overload warning	Overload warning
	3RB29 85-2AB1	Analog signal	Disconnection of the contactor (inverse-time delayed/temperature-dependent protection)	Signal "tripped"	Disconnection of the contactor (ground fault)	Signal "ground-fault tripping"

Overload Relays

SIRIUS 3RB2 Solid-State Overload Relays

3RB22, 3RB23 up to 630 A
for High-Feature applications

Function expansion modules for 3RB22 and 3RB23 overload relays (evaluation modules)

Size of contactor	Version	For over-load relays	DT	Order No.	Price € per PU	PU (UNIT, SET, M)	PS*	PG	
Sizes S00 to S12									
 3RB29 85-2..1	S00 ... S12	For plugging into evaluation module (1 unit)							
		Analog Basic 1 modules ¹⁾ Analog output DC 4 ... 20 mA, with overload warning	3RB22, 3RB23	▶	3RB29 85-2AA0		1	1 unit	41F
		Analog Basic 1 GF modules ¹⁾²⁾ Analog output DC 4 ... 20 mA, with internal ground-fault detection and overload warning	3RB22, 3RB23	▶	3RB29 85-2AA1		1	1 unit	41F
		Analog Basic 2 GF modules ¹⁾²⁾ Analog output DC 4 ... 20 mA, with internal ground-fault detection and ground-fault signal	3RB22, 3RB23	▶	3RB29 85-2AB1		1	1 unit	41F
		Basic 1 GF modules ²⁾ with internal ground-fault detection and overload warning	3RB22, 3RB23	▶	3RB29 85-2CA1		1	1 unit	41F
	Basic 2 GF modules ²⁾ with internal ground-fault detection and ground-fault signaling	3RB22, 3RB23	▶	3RB29 85-2CB1		1	1 unit	41F	

Note:

Analog input modules, e. g. SM 331, must be configured for 4-wire measuring transducers. In this case the analog input module must not supply current to the analog output of the 3RB22/3RB23 relay.

- 1) The analog signal DC 4 mA up to 20 mA can be used for operating rotary coil instruments or for feeding into analog inputs of programmable logic controllers.
- 2) The following information on ground-fault protection refers to sinusoidal residual currents at 50/60 Hz:
 - with a motor current of between 0.3 and 2 times the set current I_e the unit will trip at a ground-fault current equal to 30 % of the current setting.
 - With a motor current of between 2 and 8 times the current setting I_e the unit will trip at a ground-fault current equal to 15 % of the current setting.
 - The response delay amounts to between 0.5 s and 1 s.

Overload Relays

SIRIUS 3RB2 Solid-State Overload Relays

Current measuring modules for 3RB22, 3RB23

Overview

The current measuring modules are designed as system components for connecting to evaluation units 3RB22 and 3RB23. Using these evaluation modules the motor current is measured and the measured value sent to the evaluation unit for evaluation.

The current measuring modules in sizes S00 to S3 up to 55 mm wide are equipped with straight-through transformers and can be snap-fitted under the evaluation modules. The larger evaluation modules are installed directly on the contactor or as stand-alone units.

Selection and ordering data

Current measuring modules for mounting onto contactor¹⁾ and stand-alone installation¹⁾²⁾ (essential accessories)



3RB29 06-2-G1



3RB29 06-2-JG1



3RB29 56-2-TG2



3RB29 66-2-WH2

Size of contactor ³⁾	Rating for induction motor $P^{4)}$ kW	Current setting of the inverse-time delayed overload release A	Short-circuit protection with fuse, type of coordination "2", gG operational class ⁵⁾ A	For overload relays	DT	Order No.	Price € per PU	PU (UNIT, SET, M)	PS*	PG
Sizes S00/S0²⁾⁶⁾										
S00/S0	0,09 ... 1,1	0,3 ... 3	20	3RB22, 3RB23	▶	3RB29 06-2BG1		1	1 unit	41G
	1,1 ... 11	2,4 ... 25	63			3RB29 06-2DG1		1	1 unit	41G
Sizes S2/S3²⁾⁶⁾										
S2/S3	5,5 ... 45	10 ... 100	315	3RB22, 3RB23	▶	3RB29 06-2JG1		1	1 unit	41G
Size S6¹⁾⁶⁾										
S6 with busbar connection	11 ... 90	20 ... 200	315	3RB22, 3RB23	▶	3RB29 56-2TH2		1	1 unit	41G
For mounting to S6 contactors with box terminals				3RB22, 3RB23	▶	3RB29 56-2TG2		1	1 unit	41G
Sizes S10/S12¹⁾										
S10/S12 and size 14 (3TF68/ 3TF69)	37 ... 450	63 ... 630	800	3RB22, 3RB23	▶	3RB29 66-2WH2		1	1 unit	41G

Note:

The connecting cable between the current measuring module and the evaluation module is not included in the scope of supply; please order separately.

¹⁾ The current measuring modules with an Order No. ending with "2" are designed for mounting onto contactor and stand-alone installation. For 3TF68/3TF69 contactors, direct mounting is not possible.

²⁾ The current measuring modules with an Order No. ending with "1" are designed for stand-alone installation.

³⁾ Observe maximum rated operational current of the devices.

⁴⁾ Guide value for 4-pole standard motors at 50 Hz 400 V AC. The actual starting and rated data of the motor to be protected must be considered when selecting the units.

⁵⁾ Maximum protection by fuse only for overload relays, type of coordination "2". "Fuse Values in Connection with Contactors" see [Configuration Manual "SIRIUS Configuration – Selection Data for Fuseless Load Feeders"](#).

Accessories

Size of contactor	Version	For current measuring modules	DT	Order No.	Price € per PU	PU (UNIT, SET, M)	PS*	PG	
Connecting cables (necessary accessories)									
 3RB29 87-2.	S00 ... S3	For connection between evaluation module and current measuring module							
		• Length 0.1 m (only for mounting of the evaluation module directly onto the current measuring module)	3RB29	▶	3RB29 87-2B		1	1 unit	41F
	S00 ... S12	• Length 0.5 m	3RB29	▶	3RB29 87-2D		1	1 unit	41F

Additional general accessories see [pages 7/61 and 7/62](#).

Overload Relays

SIRIUS 3RB2 Solid-State Overload Relays

Accessories for 3RB22, 3RB23

Overview





Overload relays for High-Feature applications

The following optional accessories are available for the 3RB22 and 3RB23 solid-state overload relays:

- Sealable covers
- Terminal covers for the 3RB29 current measuring modules size S6 and S10/S12
- Box terminal blocks for the 3RB29 current measuring modules size S6 and S10/S12
- Push-in lugs for screw fixing for 3RB22, 3RB23 evaluation modules and 3RB29 06 current measuring modules

Selection and ordering data

General accessories

Version	Size	For over-load relays	DT	Order No.	Price € per PU	PU (UNIT, SET, M)	PS*	PG
Sealable covers for evaluation modules								
	For covering the setting knobs	--	3RB22, 3RB23	▶	3RB29 84-2	1	10 units	41F
Terminal covers for current measuring modules								
Covers for cable lugs and busbar connections								
	• Length 100 mm	S6	3RB29 56	▶	3RT19 56-4EA1	1	1 unit	41B
	• Length 120 mm	S10/S12	3RB29 66	▶	3RT19 66-4EA1	1	1 unit	41B
Covers for box terminals								
	• Length 25 mm	S6	3RB29 56	▶	3RT19 56-4EA2	1	1 unit	41B
	• Length 30 mm	S10/S12	3RB29 66	▶	3RT19 66-4EA2	1	1 unit	41B
Covers for screw terminals between contactor and overload relay, without box terminals (1 unit required per combination)								
	S6	3RB29 56	▶	3RT19 56-4EA3	1	1 unit	41B	
	S10/S12	3RB29 66	▶	3RT19 66-4EA3	1	1 unit	41B	
Box terminal blocks for current measuring modules								
	For round and ribbon cables							
	• Up to 70 mm ²	S6 ¹⁾	3RB29 56	▶	3RT19 55-4G	1	1 unit	41B
	• Up to 120 mm ²	S6	3RB29 56	▶	3RT19 56-4G	1	1 unit	41B
	• Up to 240 mm ²	S10/S12	3RB29 66	▶	3RT19 66-4G	1	1 unit	41B
3RT19 5.-4G	Technical specifications for conductor cross-sections see "Reference Manual for Protection Equipment – 3RU1, 3RB2 Overload Relays".							
Push-in lugs for evaluation modules and current measuring modules								
	for screw fixing the evaluation modules	--	3RB22, 3RB23	B	3RP19 03	1	10 units	41H
3RP19 03								
	for screw fixing the current measuring modules (2 units per module)	S00 ...S3	3RB29 06	A	3RB19 00-0B	100	10 units	41F
3RB19 00-0B								

¹⁾ In the scope of supply for 3RT10 54-1 contactors (55 kW).

Overload Relays

SIRIUS 3RB2 Solid-State Overload Relays

Accessories for 3RB22, 3RB23

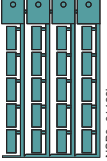
Version	Size	Color	For over-load relays	DT	Order No.	Price € per PU	PU (UNIT, SET, M)	PS*	PG
Tools for opening spring-type terminals									
	Screwdrivers For all SIRIUS devices with spring-type terminals	Length approx. 200 mm, 3.0 mm x 0.5 mm	Titanium gray/black, partially insulated	Main and auxiliary circuit connection: 3RB2	A				
3RA29 08-1A									
Blank labels									
	Unit labeling plates ¹⁾ for SIRIUS devices	20 mm x 7 mm	Pastel turquoise	3RB2	D				
3RT19 00-1SB20									

¹⁾ PC labeling system for individual inscription of unit labeling plates available from: murrplastik Systemtechnik GmbH (see Catalog IC 10 · 2012, Chapter 16, "Appendix" → "External Partners").

Load Feeders and Motor Starters for Operation in the Control Cabinet

8

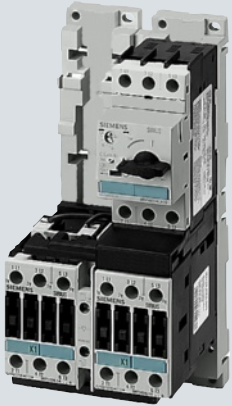

8/2 Introduction

SIRIUS 3RA1 Load Feeders

8/3 General data

3RA11 Direct-on-Line Starters

8/4 for snapping onto standard mounting rails or for screw mounting

8/8 for busbar systems

3RA12 Reversing Starters

8/12 for snapping onto standard mounting rails or for screw mounting

8/16 for busbar systems

8/20 Accessories

8/26 3RV19 infeed systems

8/26 SENTRON 8US busbar systems

More information can be found on the Internet: [see opening information on page 8](#)

Load Feeders and Motor Starters

For operation in the control cabinet

Introduction

Overview



3RA11



3RA12

Order No.

Page

SIRIUS 3RA1 load feeders

	<ul style="list-style-type: none"> The 3RA1 fuseless load feeders consist of the 3RV1 motor starter protector and the 3RT1 contactor. The motor starter protector and contactor are prewired and mechanically connected in pre-assembled assembly kits (link modules, wiring kits and standard mounting rail or busbar adapters). The motor starter protector and contactor are mechanically and electrically connected by means of the link module 4 sizes (S00, S0, S2, S3) Can be supplied for direct-on-line start or reversing duty as <ul style="list-style-type: none"> - complete unit or - single devices for self-assembly 		
3RA11 direct-on-line starters for snapping onto standard mounting rails or for screw mounting	<ul style="list-style-type: none"> Rated control supply voltage 230 V AC, 50 Hz and 24 V DC, for 35 mm standard mounting rail or for screw mounting 	3RA11	8/4
3RA11 direct-on-line starters for busbar systems	<ul style="list-style-type: none"> Rated control supply voltage 230 V AC, 50 Hz and 24 V DC, for 40 and 60 mm busbar systems 	3RA11	8/8
3RA12 reversing starters for snapping onto standard mounting rails or for screw mounting	<ul style="list-style-type: none"> Rated control supply voltage 230 V AC, 50 Hz and 24 V DC, for 35 mm standard mounting rail or for screw mounting 	3RA12	8/12
3RA12 reversing starters for busbar systems	<ul style="list-style-type: none"> Rated control supply voltage 230 V AC, 50 Hz and 24 V DC, for 40 and 60 mm busbar systems 	3RA12	8/16
3RV19 infeed systems	<ul style="list-style-type: none"> Convenient means of energy supply and distribution 	3RV19	8/26

Overview

3RA1 fuseless load feeders

The 3RA1 fuseless load feeders consist of the 3RV1 motor starter protector and the 3RT1 contactor. Motor starter protectors and contactors are electrically and mechanically connected using pre-assembled assembly kits (link modules, wiring kits and standard mounting rail or busbar adapters).

As the 3RA1 fuseless load feeders are constructed from 3RV1 motor starter protectors and 3RT1 contactors, the same accessories can be used for the 3RA fuseless load feeders as for these motor starter protectors and contactors.

Pre-assembled link modules are available as accessories for the power spectrum up to 45 kW. The desired fuseless load feeder can thus be assembled quickly and economically by the customer. A time saving is also achieved in connection with switch-gear acceptances, as – unlike with conventional wiring systems – there is no need to rectify possible wiring errors.

The 3RV1 motor starter protector is responsible for overload and short-circuit protection in the fuseless load feeder. Back-up protective devices, such as melting fuses or limiters, are superfluous here, as the circuit breaker is capable of withstanding short circuits of up to 50 or 100 kA at 400 V.

The 3RT1 contactor is particularly suitable for extremely complex switching tasks requiring the greatest endurance.

The permissible ambient temperature is 60 °C with close-to-close-mounting and without derating (70 °C possible subject to certain restrictions).

3RA1 fuseless load feeders are available for motors up to 45 kW at AC-3 and 400 V (grounded network) and setting ranges from 0.14 A to 100 A.

3RA1 fuseless load feeders are supplied in four different sizes:

Size	Width mm	Max. rated current $I_{n \max}$ A	For induction motors up to kW
S00	45	12	5,5
S0	45	25	11
S2	55	50	22
S3	70	100	45

The SENTRON 3VL circuit breakers and the SIRIUS 3RT contactors can be used for fuseless load feeders >100 A. The corresponding distances from grounded or live parts, as detailed in the technical specifications, must be observed.

More information and assignment tables for self-assembly combinations for 400 V, 440 V, 480 V, 500 V, 550 V and 690 V see the [configuration manual "SIRIUS Configuration: Selection Data for Fuseless Load Feeders"](#), see page 8/25.

Operating conditions

3RA1 load feeders are climate-proof. They are intended for use in enclosed rooms in which no severe operating conditions (such as dust, caustic vapors, hazardous gases) prevail. Suitable covers must be provided for installation in dusty and damp locations.

Overload tripping times

All 3RA1 fuseless load feeders described here are designed for normal starting, in other words for overload tripping times of less than 10 s (CLASS 10). At rated-load operating temperature the tripping times are shorter, depending on the particular equipment and the setting range. The exact values can be derived from the tripping characteristics of the motor starter protectors.

Types of coordination

IEC 60947-4-1 makes a distinction between two different types of coordination (types "1" and "2"). Any short circuits that occur are cleared safely by both types of coordination. The only differences concern the extent of the damage caused to the device by a short circuit.

TOC
1

Type of coordination "1"

The fuseless load feeder may be non-operational after a short circuit has been cleared. Damage to the contactor or to the overload release is permissible. For 3RA1 load feeders, the motor starter protector itself always achieves type of coordination "2".

TOC
2

Type of coordination "2"

There must be no damage to the overload release or to any other components after a short circuit has been cleared. The 3RA1 fuseless load feeder can resume operation without needing to be renewed. At most, welding of the contactor contacts is permissible if they can be disconnected easily without any significant deformation.

These types of coordination are indicated in the selection and ordering data by orange backgrounds.

For Operation in the Control Cabinet

SIRIUS 3RA1 load feeders

3RA11 direct-on-line starters for snapping onto standard mounting rails or for screw mounting

Selection and ordering data

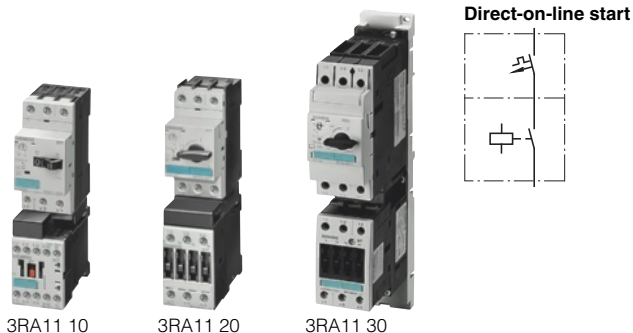

**Rated control supply voltage 50 Hz 230 V AC¹⁾
for TH 35 standard mounting rail or screw mounting**

- Motor starter protector and contactor are linked electrically and mechanically by means of a link module
- As from size S2 with standard mounting rail adapter²⁾ for mechanical reinforcement
- Auxiliary switches³⁾ on the motor starter protector and the contactor can be easily fitted due to the modular system (on contactor size S00: 1 NO integrated)

Size	Standard induction motor 4-pole at 400 V AC ⁴⁾	Setting range for thermal overload release	Consisting of the following single devices	DT	Fuseless load feeders	PU (UNIT, SET, M)	PS*	PG
	Standard output P kW	Motor current I (guide value) A	Motor starter protectors + Contactor + Link module + Standard mounting rail adapter		Order No.	Price € per PU		

Type of coordination "2" at $I_q = 50 \text{ kA}/100 \text{ kA}$ at 400 V (compatible with type of coordination "1")⁵⁾

				3RV10	3RT10	3RA19							
S00	0,06	0,2	0,14 ... 0,2	11-0BA10	15-1AP01	11-1AA00	A	3RA11 10-0BA15-1AP0	1	1 unit	41D		
	0,06	0,2	0,18 ... 0,25	11-0CA10		+ ⁶⁾	A	3RA11 10-0CA15-1AP0	1	1 unit	41D		
	0,09	0,3	0,22 ... 0,32	11-0DA10			A	3RA11 10-0DA15-1AP0	1	1 unit	41D		
	0,09	0,3	0,28 ... 0,4	11-0EA10			A	3RA11 10-0EA15-1AP0	1	1 unit	41D		
	0,12	0,4	0,35 ... 0,5	11-0FA10			A	3RA11 10-0FA15-1AP0	1	1 unit	41D		
	0,18	0,6	0,45 ... 0,63	11-0GA10			A	3RA11 10-0GA15-1AP0	1	1 unit	41D		
	0,18	0,6	0,55 ... 0,8	11-0HA10			A	3RA11 10-0HA15-1AP0	1	1 unit	41D		
	0,25	0,85	0,7 ... 1	11-0JA10			A	3RA11 10-0JA15-1AP0	1	1 unit	41D		
	0,37	1,1	0,9 ... 1,25	11-0KA10			A	3RA11 10-0KA15-1AP0	1	1 unit	41D		
	0,55	1,5	1,1 ... 1,6	11-1AA10			A	3RA11 10-1AA15-1AP0	1	1 unit	41D		
	0,75	1,9	1,4 ... 2	11-1BA10			A	3RA11 10-1BA15-1AP0	1	1 unit	41D		
	S0	0,75	1,9	1,8 ... 2,5	21-1CA10	24-1AP00	21-1AA00	A	3RA11 20-1CA24-0AP0	1	1 unit	41D	
		1,1	2,7	2,2 ... 3,2	21-1DA10		+ ⁶⁾	A	3RA11 20-1DA24-0AP0	1	1 unit	41D	
		1,5	3,6	2,8 ... 4	21-1EA10			A	3RA11 20-1EA24-0AP0	1	1 unit	41D	
1,5		3,6	3,5 ... 5	21-1FA10			A	3RA11 20-1FA24-0AP0	1	1 unit	41D		
2,2		4,9	4,5 ... 6,3	21-1GA10			A	3RA11 20-1GA24-0AP0	1	1 unit	41D		
3		6,5	5,5 ... 8	21-1HA10			A	3RA11 20-1HA24-0AP0	1	1 unit	41D		
4		8,5	7 ... 10	21-1JA10	26-1AP00		A	3RA11 20-1JA26-0AP0	1	1 unit	41D		
5,5		11,5	9 ... 12,5	21-1KA10			A	3RA11 20-1KA26-0AP0	1	1 unit	41D		
7,5		15,5	11 ... 16	21-4AA10			A	3RA11 20-4AA26-0AP0	1	1 unit	41D		
7,5		15,5	14 ... 20	21-4BA10			A	3RA11 20-4BA26-0AP0	1	1 unit	41D		
S2	11	22	18 ... 25	31-4DA10	34-1AP00	31-1AA00	A	3RA11 30-4DB34-0AP0	1	1 unit	41D		
	15	29	22 ... 32	31-4EA10		+	A	3RA11 30-4EB34-0AP0	1	1 unit	41D		
	18,5	35	28 ... 40	31-4FA10	35-1AP00	32-1AA00	A	3RA11 30-4FB35-0AP0	1	1 unit	41D		
	22	41	36 ... 45	31-4GA10	36-1AP00		A	3RA11 30-4GB36-0AP0	1	1 unit	41D		
	22	41	40 ... 50	31-4HA10			A	3RA11 30-4HB36-0AP0	1	1 unit	41D		
S3	30	55	45 ... 63	41-4JA10	44-1AP00	41-1AA00							
	37	66	57 ... 75	41-4KA10	45-1AP00	+							
	45	80	70 ... 90	41-4LA10	46-1AP00	42-1AA00							
	45	80	80 ... 100	41-4MA10									

Size S3 is only available for self-assembly.

¹⁾ Size S00 also suitable for 60 Hz.

²⁾ Standard mounting rail adapter is also suitable for screw mounting.

³⁾ Auxiliary switches see "Accessories for Direct-On-Line and Reversing Starters".

⁴⁾ Selection depends on the concrete startup and rated data of the protected motor.



⁵⁾ Load feeders with $I_q \geq 100 \text{ kA}$ see notes on "Technical Information" on page 8.

⁶⁾ Screw mounting with 1 push-in lug each per load feeder is possible (see "Accessories for Direct-On-Line and Reversing Starters").

For Operation in the Control Cabinet

SIRIUS 3RA1 load feeders

3RA11 direct-on-line starters for snapping onto standard mounting rails or for screw mounting

Size	Standard induction motor 4-pole at 400 V AC ¹⁾		Setting range for thermal overload release 	Consisting of the following single devices			DT	Fuseless load feeders 		PU (UNIT, SET, M)	PS*	PG
	Standard output P	Motor current I (guide value)		Motor starter protectors	+ Contactor	+ Link module + Standard mounting rail adapter		Order No.	Price € per PU			
	kW	A	A									
Type of coordination "1" at $I_q = 50 \text{ kA}$ at 400 V²⁾ (the motor starter protector is compatible with type of coordination "2")												
S00	0,75	1,9	1,4 ... 2									For load feeders for lower outputs, see table above (type of coordination "2").
				3RV10	3RT10	3RA19						
S00	0,75	1,9	1,8 ... 2,5	11-1CA10	15-1AP01	11-1AA00	A	3RA11 10-1CA15-1AP0		1	1 unit	41D
	1,1	2,7	2,2 ... 3,2	11-1DA10		⁺³⁾	A	3RA11 10-1DA15-1AP0		1	1 unit	41D
	1,5	3,6	2,8 ... 4	11-1EA10			A	3RA11 10-1EA15-1AP0		1	1 unit	41D
	1,5	3,6	3,5 ... 5	11-1FA10			A	3RA11 10-1FA15-1AP0		1	1 unit	41D
	2,2	4,9	4,5 ... 6,3	11-1GA10			A	3RA11 10-1GA15-1AP0		1	1 unit	41D
	3	6,5	5,5 ... 8	11-1HA10			A	3RA11 10-1HA15-1AP0		1	1 unit	41D
	4	8,5	7 ... 10	11-1JA10	16-1AP01		A	3RA11 10-1JA16-1AP0		1	1 unit	41D
	5,5	11,5	9 ... 12	11-1KA10	17-1AP01		A	3RA11 10-1KA17-1AP0		1	1 unit	41D
S0	7,5	15,5	11 ... 16	21-4AA10	25-1AP00	21-1AA00	A	3RA11 20-4AA25-0AP0		1	1 unit	41D
	7,5	15,5	14 ... 20	21-4BA10		⁺³⁾	A	3RA11 20-4BA25-0AP0		1	1 unit	41D
	11	22	17 ... 22	21-4CA10	26-1AP00		A	3RA11 20-4CA26-0AP0		1	1 unit	41D
	11	22	18 ... 25	21-4DA10	26-1AP00		A	3RA11 20-4DA26-0AP0		1	1 unit	41D
S2	15	29	22 ... 32									For load feeders for higher outputs, see table above (type of coordination "2").
	18,5	35	28 ... 40									
	22	41	36 ... 45									
			...									

1) Selection depends on the concrete startup and rated data of the protected motor.

2) Load feeders with $I_q \geq 100 \text{ kA}$ see notes on "Technical Information" on page 8.

3) Screw mounting with 1 push-in lug each per load feeder is possible (see "Accessories for Direct-On-Line and Reversing Starters").

For Operation in the Control Cabinet

SIRIUS 3RA1 load feeders

3RA11 direct-on-line starters for snapping onto standard mounting rails or for screw mounting

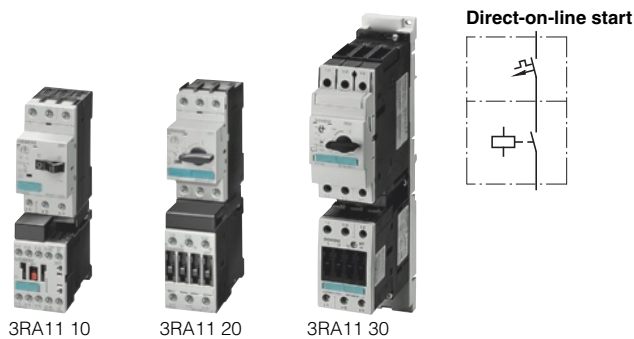

Rated control supply voltage 24 V DC for TH 35 standard mounting rail or screw mounting

- Motor starter protector and contactor are linked electrically and mechanically by means of a link module
- As from size S2 with standard mounting rail adapter¹⁾ for mechanical reinforcement
- Auxiliary switches²⁾ on the motor starter protector and the contactor can be easily fitted due to the modular system (on contactor size S00: 1 NO integrated)

Size	Standard induction motor 4-pole at 400 V AC ³⁾	Setting range for thermal overload release	Consisting of the following single devices			DT	Fuseless load feeders	$I_{\text{thC}} 2$	PU (UNIT, SET, M)	PS*	PG
	Standard output P	Motor current I (guide value)	Motor starter protectors	+ Contactor	+ Link module + Standard mounting rail adapter		Order No.	Price € per PU			
	kW	A									

Type of coordination "2" at $I_{\text{q}} = 50 \text{ kA}/100 \text{ kA}$ at 400 V (compatible with type of coordination "1")⁴⁾

			3RV10	3RT10	3RA19						
S00	0,06	0,2	0,14 ... 0,2	11-0BA10	15-1BB41	11-1AA00	A	3RA11 10-0BA15-1BB4	1	1 unit	41D
	0,06	0,2	0,18 ... 0,25	11-0CA10		+ ⁵⁾	A	3RA11 10-0CA15-1BB4	1	1 unit	41D
	0,09	0,3	0,22 ... 0,32	11-0DA10			A	3RA11 10-0DA15-1BB4	1	1 unit	41D
	0,09	0,3	0,28 ... 0,4	11-0EA10			A	3RA11 10-0EA15-1BB4	1	1 unit	41D
	0,12	0,4	0,35 ... 0,5	11-0FA10			A	3RA11 10-0FA15-1BB4	1	1 unit	41D
	0,18	0,6	0,45 ... 0,63	11-0GA10			A	3RA11 10-0GA15-1BB4	1	1 unit	41D
	0,18	0,6	0,55 ... 0,8	11-0HA10			A	3RA11 10-0HA15-1BB4	1	1 unit	41D
	0,25	0,85	0,7 ... 1	11-0JA10			A	3RA11 10-0JA15-1BB4	1	1 unit	41D
	0,37	1,1	0,9 ... 1,25	11-0KA10			A	3RA11 10-0KA15-1BB4	1	1 unit	41D
	0,55	1,5	1,1 ... 1,6	11-1AA10			A	3RA11 10-1AA15-1BB4	1	1 unit	41D
	0,75	1,9	1,4 ... 2	11-1BA10			A	3RA11 10-1BA15-1BB4	1	1 unit	41D
	S0	0,75	1,9	1,8 ... 2,5	21-1CA10	24-1BB40	21-1BA00	A	3RA11 20-1CA24-0BB4	1	1 unit
1,1		2,7	2,2 ... 3,2	21-1DA10		+ ⁵⁾	A	3RA11 20-1DA24-0BB4	1	1 unit	41D
1,5		3,6	2,8 ... 4	21-1EA10			A	3RA11 20-1EA24-0BB4	1	1 unit	41D
1,5		3,6	3,5 ... 5	21-1FA10			A	3RA11 20-1FA24-0BB4	1	1 unit	41D
2,2		4,9	4,5 ... 6,3	21-1GA10			A	3RA11 20-1GA24-0BB4	1	1 unit	41D
3		6,5	5,5 ... 8	21-1HA10			A	3RA11 20-1HA24-0BB4	1	1 unit	41D
4		8,5	7 ... 10	21-1JA10	26-1BB40		A	3RA11 20-1JA26-0BB4	1	1 unit	41D
5,5		11,5	9 ... 12,5	21-1KA10			A	3RA11 20-1KA26-0BB4	1	1 unit	41D
7,5		15,5	11 ... 16	21-4AA10			A	3RA11 20-4AA26-0BB4	1	1 unit	41D
7,5		15,5	14 ... 20	21-4BA10			A	3RA11 20-4BA26-0BB4	1	1 unit	41D
S2		11	22	18 ... 25	31-4DA10	34-1BB40	31-1BA00	A	3RA11 30-4DB34-0BB4	1	1 unit
	15	29	22 ... 32	31-4EA10		+	A	3RA11 30-4EB34-0BB4	1	1 unit	41D
	18,5	35	28 ... 40	31-4FA10	35-1BB40	32-1AA00	A	3RA11 30-4FB35-0BB4	1	1 unit	41D
	22	41	36 ... 45	31-4GA10	36-1BB40		A	3RA11 30-4GB36-0BB4	1	1 unit	41D
	22	41	40 ... 50	31-4HA10			A	3RA11 30-4HB36-0BB4	1	1 unit	41D
S3	30	55	45 ... 63	41-4JA10	44-1BB40	41-1BA00					
	37	66	57 ... 75	41-4KA10	45-1BB40	+					
	45	80	70 ... 90	41-4LA10	46-1BB40						
	45	80	80 ... 100	41-4MA10							



Size S3 is only available for self-assembly.

- Standard mounting rail adapter is also suitable for screw mounting.
- Auxiliary switches see "Accessories for Direct-On-Line and Reversing Starters".
- Selection depends on the concrete startup and rated data of the protected motor.
- Load feeders with $I_{\text{q}} \geq 100 \text{ kA}$ see notes on "Technical Information" on page 8.
- Screw mounting with 1 push-in lug each per load feeder is possible (see "Accessories for Direct-On-Line and Reversing Starters").

For Operation in the Control Cabinet

SIRIUS 3RA1 load feeders

3RA11 direct-on-line starters for snapping onto standard mounting rails or for screw mounting

Size	Standard induction motor 4-pole at 400 V AC ¹⁾		Setting range for thermal overload release 	Consisting of the following single devices			DT	Fuseless load feeders 		PU (UNIT, SET, M)	PS*	PG
	Standard output P	Motor current I (guide value)		Motor starter protectors	+ Contactor	+ Link module + Standard mounting rail adapter		Order No.	Price € per PU			
	kW	A	A									
Type of coordination "1" at $I_q = 50$ kA at 400 V²⁾ (the motor starter protector is compatible with type of coordination "2")												
S00	0,75	1,9	1,4 ... 2	For load feeders for lower outputs, see table above (type of coordination "2").								
				3RV10	3RT10	3RA19						
S00	0,75	1,9	1,8 ... 2,5	11-1CA10	15-1BB41	11-1AA00	A	3RA11 10-1CA15-1BB4		1	1 unit	41D
	1,1	2,7	2,2 ... 3,2	11-1DA10		⁺³⁾	A	3RA11 10-1DA15-1BB4		1	1 unit	41D
	1,5	3,6	2,8 ... 4	11-1EA10			A	3RA11 10-1EA15-1BB4		1	1 unit	41D
	1,5	3,6	3,5 ... 5	11-1FA10			A	3RA11 10-1FA15-1BB4		1	1 unit	41D
	2,2	4,9	4,5 ... 6,3	11-1GA10			A	3RA11 10-1GA15-1BB4		1	1 unit	41D
	3	6,5	5,5 ... 8	11-1HA10			A	3RA11 10-1HA15-1BB4		1	1 unit	41D
	4	8,5	7 ... 10	11-1JA10	16-1BB41		A	3RA11 10-1JA16-1BB4		1	1 unit	41D
	5,5	11,5	9 ... 12	11-1KA10	17-1BB41		A	3RA11 10-1KA17-1BB4		1	1 unit	41D
S0	7,5	15,5	11 ... 16	21-4AA10	25-1BB40	21-1BA00	A	3RA11 20-4AA25-0BB4		1	1 unit	41D
	7,5	15,5	14 ... 20	21-4BA10		⁺³⁾	A	3RA11 20-4BA25-0BB4		1	1 unit	41D
	11	22	17 ... 22	21-4CA10	26-1BB40		A	3RA11 20-4CA26-0BB4		1	1 unit	41D
	11	22	18 ... 25	21-4DA10			A	3RA11 20-4DA26-0BB4		1	1 unit	41D
S2	15	29	22 ... 32	For load feeders for higher outputs, see table above (type of coordination "2").								
	18,5	35	28 ... 40									
	22	41	36 ... 45									
			...									

1) Selection depends on the concrete startup and rated data of the protected motor.

2) Load feeders with $I_q \geq 100$ kA see notes on "Technical Information" on page 8.

3) Screw mounting with 1 push-in lug each per load feeder is possible (see "Accessories for Direct-On-Line and Reversing Starters").

For Operation in the Control Cabinet

SIRIUS 3RA1 load feeders

3RA11 direct-on-line starters for busbar systems

Selection and ordering data



3RA11 10

3RA11 20

Direct-on-line start

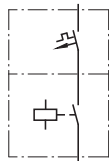

Rated control supply voltage 50 Hz 230 V AC¹⁾ for 40 and 60 mm busbar systems

- Motor starter protector and contactor are linked electrically and mechanically by means of a link module
- Auxiliary switches²⁾ on the motor starter protector and the contactor can be easily fitted due to the modular system (on contactor size S00: 1 NO integrated)

Size	Standard induction motor 4-pole at 400 V AC ³⁾	Setting range for thermal overload release	Consisting of the following single devices	DT	Fuseless load feeders	ToC 2	PU (UNIT, SET, M)	PS*	PG
	Standard output P	Motor current I (guide value)	Motor starter protectors		Order No.	Price € per PU			
	kW	A	+ Contactor						
		A	+ Link module + Busbar adapter						

Type of coordination "2" at $I_{ca} = 50 \text{ kA}$ at 400 V (compatible with type of coordination "1")

			3RV10		3RT10						
S00	0,06	0,2	0,14 ... 0,2	11-0BA10	15-1AP01	3RA19 11-1AA00	A	3RA11 10-0B□15-1AP0	1	1 unit	41D
	0,06	0,2	0,18 ... 0,25	11-0CA10		+	A	3RA11 10-0C□15-1AP0	1	1 unit	41D
	0,09	0,3	0,22 ... 0,32	11-0DA10		40 mm:	A	3RA11 10-0D□15-1AP0	1	1 unit	41D
	0,09	0,3	0,28 ... 0,4	11-0EA10		8US10 51-5DM07	A	3RA11 10-0E□15-1AP0	1	1 unit	41D
	0,12	0,4	0,35 ... 0,5	11-0FA10		or 60 mm:	A	3RA11 10-0F□15-1AP0	1	1 unit	41D
	0,18	0,6	0,45 ... 0,63	11-0GA10		8US12 51-5DM07	A	3RA11 10-0G□15-1AP0	1	1 unit	41D
	0,18	0,6	0,55 ... 0,8	11-0HA10			A	3RA11 10-0H□15-1AP0	1	1 unit	41D
	0,25	0,85	0,7 ... 1	11-0JA10			A	3RA11 10-0J□15-1AP0	1	1 unit	41D
	0,37	1,1	0,9 ... 1,25	11-0KA10			A	3RA11 10-0K□15-1AP0	1	1 unit	41D
	0,55	1,5	1,1 ... 1,6	11-1AA10			A	3RA11 10-1A□15-1AP0	1	1 unit	41D
	0,75	1,9	1,4 ... 2	11-1BA10			A	3RA11 10-1B□15-1AP0	1	1 unit	41D
S0	0,75	1,9	1,8 ... 2,5	21-1CA10	24-1AP00	3RA19 21-1AA00	A	3RA11 20-1C□24-0AP0	1	1 unit	41D
	1,1	2,7	2,2 ... 3,2	21-1DA10		+	A	3RA11 20-1D□24-0AP0	1	1 unit	41D
	1,5	3,6	2,8 ... 4	21-1EA10		40 mm:	A	3RA11 20-1E□24-0AP0	1	1 unit	41D
	1,5	3,6	3,5 ... 5	21-1FA10		8US10 51-5DM07	A	3RA11 20-1F□24-0AP0	1	1 unit	41D
	2,2	4,9	4,5 ... 6,3	21-1GA10		or 60 mm:	A	3RA11 20-1G□24-0AP0	1	1 unit	41D
	3	6,5	5,5 ... 8	21-1HA10		8US12 51-5DM07	A	3RA11 20-1H□24-0AP0	1	1 unit	41D
	4	8,5	7 ... 10	21-1JA10	26-1AP00		A	3RA11 20-1J□26-0AP0	1	1 unit	41D
	5,5	11,5	9 ... 12,5	21-1KA10			A	3RA11 20-1K□26-0AP0	1	1 unit	41D
	7,5	15,5	11 ... 16	21-4AA10			A	3RA11 20-4A□26-0AP0	1	1 unit	41D
	7,5	15,5	14 ... 20	21-4BA10			A	3RA11 20-4B□26-0AP0	1	1 unit	41D
S2	11	22	18 ... 25	31-4DA10	34-1AP00	3RA19 31-1AA00	A	Size S2 is only available for self-assembly.			
	15	29	22 ... 32	31-4EA10		+	A				
	18,5	35	28 ... 40	31-4FA10	35-1AP00	40 mm:	A				
	22	41	36 ... 45	31-4GA10	36-1AP00	8US10 61-5FP08	A				
	22	41	40 ... 50	31-4HA10		or 60 mm:	A				
						8US12 61-5FP08	A				
S3	30	55	45 ... 63	41-4JA10	44-1AP00	3RA19 41-1AA00	A	For size S3, a busbar adapter is not necessary.			
	37	66	57 ... 75	41-4KA10	45-1AP00						
	45	80	70 ... 90	41-4LA10	46-1AP00						
	45	80	80 ... 100	41-4MA10							

Order No. supplement for busbar center-to-center spacing

40 mm
60 mm

¹⁾ Size S00 also suitable for 60 Hz.

²⁾ Auxiliary switches see "Accessories for Direct-On-Line and Reversing Starters".

³⁾ Selection depends on the concrete startup and rated data of the protected motor.

C
D

For Operation in the Control Cabinet

SIRIUS 3RA1 load feeders

**3RA11 direct-on-line starters
for busbar systems**

Size	Standard induction motor 4-pole at 400 V AC ¹⁾		Setting range for thermal overload release 	Consisting of the following single devices			DT	Fuseless load feeders	TOC 1	PU (UNIT, SET, M)	PS*	PG
	Standard output P	Motor current I (guide value)		Motor starter protectors	+ Contactor	+ Link module + Busbar adapter						
	kW	A	A									
Type of coordination "1" at $I_q = 50$ kA at 400 V (the motor starter protector is compatible with type of coordination "2")												
S00	0,75	1,9	1,4 ... 2									For load feeders for lower outputs, see table above (type of coordination "2").
				3RV10	3RT10							
S00	0,75	1,9	1,8 ... 2,5	11-1CA10	15-1AP01	3RA19 11-1AA00	A	3RA11 10-1C □15-1AP0		1	1 unit	41D
	1,1	2,7	2,2 ... 3,2	11-1DA10		+	A	3RA11 10-1D □15-1AP0		1	1 unit	41D
	1,5	3,6	2,8 ... 4	11-1EA10		40 mm:	A	3RA11 10-1E □15-1AP0		1	1 unit	41D
	1,5	3,6	3,5 ... 5	11-1FA10		8US10 51-5DM07	A	3RA11 10-1F □15-1AP0		1	1 unit	41D
	2,2	4,9	4,5 ... 6,3	11-1GA10		or 60 mm:	A	3RA11 10-1G □15-1AP0		1	1 unit	41D
	3	6,5	5,5 ... 8	11-1HA10		8US12 51-5DM07	A	3RA11 10-1H □15-1AP0		1	1 unit	41D
	4	8,5	7 ... 10	11-1JA10	16-1AP01		A	3RA11 10-1J □16-1AP0		1	1 unit	41D
	5,5	11,5	9 ... 12	11-1KA10	17-1AP01		A	3RA11 10-1K □17-1AP0		1	1 unit	41D
S0	7,5	15,5	11 ... 16	21-4AA10	25-1AP00	3RA19 21-1AA00	A	3RA11 20-4A □25-0AP0		1	1 unit	41D
	7,5	15,5	14 ... 20	21-4BA10		+	A	3RA11 20-4B □25-0AP0		1	1 unit	41D
	11	22	17 ... 22	21-4CA10	26-1AP00	40 mm:	A	3RA11 20-4C □26-0AP0		1	1 unit	41D
	11	22	18 ... 25	21-4DA10		8US10 51-5DM07	A	3RA11 20-4D □26-0AP0		1	1 unit	41D
						or 60 mm:						
						8US12 51-5DM07						
S2	15	29	22 ... 32									For load feeders for higher outputs, see table above (type of coordination "2").
	18,5	35	28 ... 40									
	22	41	36 ... 45									
			...									

Order No. supplement for busbar center-to-center spacing

40 mm
60 mm

C
D

¹⁾ Selection depends on the concrete startup and rated data of the protected motor.

For Operation in the Control Cabinet

SIRIUS 3RA1 load feeders

3RA11 direct-on-line starters for busbar systems



Direct-on-line start

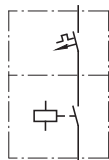

Rated control supply voltage 24 V DC for 40 and 60 mm busbar systems

- Motor starter protector and contactor are linked electrically and mechanically by means of a link module
- Auxiliary switches¹⁾ on the motor starter protector and the contactor can be easily fitted due to the modular system (on contactor size S00: 1 NO integrated)

Size	Standard induction motor 4-pole at 400 V AC ²⁾	Setting range for thermal overload release	Consisting of the following single devices			DT	Fuseless load feeders	ToC 2	PU (UNIT, SET, M)	PS*	PG
	Standard output P kW	Motor current I (guide value) A	Setting range for thermal overload release A	Motor starter protectors	+ Contactor	+ Link module + Busbar adapter	Order No.	Price € per PU			

Type of coordination "2" at I_q = 50 kA at 400 V (compatible with type of coordination "1")

	3RV10		3RT10									
S00	0,06	0,2	0,14 ... 0,2	11-0BA10	15-1BB41	3RA19 11-1AA00	A	3RA11 10-0B□15-1BB4	1	1 unit	41D	
	0,06	0,2	0,18 ... 0,25	11-0CA10		+	A	3RA11 10-0C□15-1BB4	1	1 unit	41D	
	0,09	0,3	0,22 ... 0,32	11-0DA10		40 mm:	A	3RA11 10-0D□15-1BB4	1	1 unit	41D	
	0,09	0,3	0,28 ... 0,4	11-0EA10		8US10 51-5DM07	A	3RA11 10-0E□15-1BB4	1	1 unit	41D	
	0,12	0,4	0,35 ... 0,5	11-0FA10		or 60 mm:	A	3RA11 10-0F□15-1BB4	1	1 unit	41D	
	0,18	0,6	0,45 ... 0,63	11-0GA10		8US12 51-5DM07	A	3RA11 10-0G□15-1BB4	1	1 unit	41D	
	0,18	0,6	0,55 ... 0,8	11-0HA10			A	3RA11 10-0H□15-1BB4	1	1 unit	41D	
	0,25	0,85	0,7 ... 1	11-0JA10			A	3RA11 10-0J□15-1BB4	1	1 unit	41D	
	0,37	1,1	0,9 ... 1,25	11-0KA10			A	3RA11 10-0K□15-1BB4	1	1 unit	41D	
	0,55	1,5	1,1 ... 1,6	11-1AA10			A	3RA11 10-1A□15-1BB4	1	1 unit	41D	
	0,75	1,9	1,4 ... 2	11-1BA10			A	3RA11 10-1B□15-1BB4	1	1 unit	41D	
	S0	0,75	1,9	1,8 ... 2,5	21-1CA10	24-1BB40	3RA19 21-1BA00	A	3RA11 20-1C□24-0BB4	1	1 unit	41D
1,1		2,7	2,2 ... 3,2	21-1DA10		+	A	3RA11 20-1D□24-0BB4	1	1 unit	41D	
1,5		3,6	2,8 ... 4	21-1EA10		40 mm:	A	3RA11 20-1E□24-0BB4	1	1 unit	41D	
1,5		3,6	3,5 ... 5	21-1FA10		8US10 51-5DM07	A	3RA11 20-1F□24-0BB4	1	1 unit	41D	
2,2		4,9	4,5 ... 6,3	21-1GA10		or 60 mm:	A	3RA11 20-1G□24-0BB4	1	1 unit	41D	
3		6,5	5,5 ... 8	21-1HA10		8US12 51-5DM07	A	3RA11 20-1H□24-0BB4	1	1 unit	41D	
4		8,5	7 ... 10	21-1JA10	26-1BB40		A	3RA11 20-1J□26-0BB4	1	1 unit	41D	
5,5		11,5	9 ... 12,5	21-1KA10			A	3RA11 20-1K□26-0BB4	1	1 unit	41D	
7,5		15,5	11 ... 16	21-4AA10			A	3RA11 20-4A□26-0BB4	1	1 unit	41D	
7,5		15,5	14 ... 20	21-4BA10			A	3RA11 20-4B□26-0BB4	1	1 unit	41D	
S2	11	22	18 ... 25	31-4DA10	34-1BB40	3RA19 31-1BA00		Size S2 is only available for self-assembly.				
	15	29	22 ... 32	31-4EA10		+						
	18,5	35	28 ... 40	31-4FA10	35-1BB40	40 mm:						
	22	41	36 ... 45	31-4GA10	36-1BB40	8US10 61-5FP08						
	22	41	40 ... 50	31-4HA10		or 60 mm:						
S3	30	55	45 ... 63	41-4JA10	44-1BB40	3RA19 41-1BA00		For size S3, a busbar adapter is not necessary.				
	37	66	57 ... 75	41-4KA10	45-1BB40	+						
	45	80	70 ... 90	41-4LA10	46-1BB40	not available						
	45	80	80 ... 100	41-4MA10								

Order No. supplement for busbar center-to-center spacing

- 40 mm
- 60 mm

C
D

¹⁾ Auxiliary switches see "Accessories for Direct-On-Line and Reversing Starters".
²⁾ Selection depends on the concrete startup and rated data of the protected motor.

For Operation in the Control Cabinet

SIRIUS 3RA1 load feeders

**3RA11 direct-on-line starters
for busbar systems**

Size	Standard induction motor 4-pole at 400 V AC ¹⁾		Setting range for thermal overload release 	Consisting of the following single devices			DT	Fuseless load feeders	TOC 1	PU (UNIT, SET, M)	PS*	PG
	Standard output P	Motor current I (guide value)		Motor starter protectors	+ Contactor	+ Link module + Busbar adapter						
	kW	A	A									
Type of coordination "1" at $I_q = 50$ kA at 400 V (the motor starter protector is compatible with type of coordination "2")												
S00	0,75	1,9	1,4 ... 2									For load feeders for lower outputs, see table above (type of coordination "2").
				3RV10	3RT10							
S00	0,75	1,9	1,8 ... 2,5	11-1CA10	15-1BB41	3RA19 11-1AA00	A	3RA11 10-1C □15-1BB4		1	1 unit	41D
	1,1	2,7	2,2 ... 3,2	11-1DA10		+	A	3RA11 10-1D □15-1BB4		1	1 unit	41D
	1,5	3,6	2,8 ... 4	11-1EA10		40 mm:	A	3RA11 10-1E □15-1BB4		1	1 unit	41D
	1,5	3,6	3,5 ... 5	11-1FA10		8US10 51-5DM07	A	3RA11 10-1F □15-1BB4		1	1 unit	41D
	2,2	4,9	4,5 ... 6,3	11-1GA10		or 60 mm:	A	3RA11 10-1G □15-1BB4		1	1 unit	41D
	3	6,5	5,5 ... 8	11-1HA10		8US12 51-5DM07	A	3RA11 10-1H □15-1BB4		1	1 unit	41D
	4	8,5	7 ... 10	11-1JA10	16-1BB41		A	3RA11 10-1J □16-1BB4		1	1 unit	41D
	5,5	11,5	9 ... 12	11-1KA10	17-1BB41		A	3RA11 10-1K □17-1BB4		1	1 unit	41D
S0	7,5	15,5	11 ... 16	21-4AA10	25-1BB40	3RA19 21-1BA00	A	3RA11 20-4A □25-0BB4		1	1 unit	41D
	7,5	15,5	14 ... 20	21-4BA10		+	A	3RA11 20-4B □25-0BB4		1	1 unit	41D
	11	22	17 ... 22	21-4CA10	26-1BB40	40 mm:	A	3RA11 20-4C □26-0BB4		1	1 unit	41D
	11	22	18 ... 25	21-4DA10		8US10 51-5DM07	A	3RA11 20-4D □26-0BB4		1	1 unit	41D
						or 60 mm:						
						8US12 51-5DM07						
S2	15	29	22 ... 32									For load feeders for higher outputs, see table above (type of coordination "2").
	18,5	35	28 ... 40									
	22	41	36 ... 45									
			...									

Order No. supplement for busbar center-to-center spacing

40 mm
60 mm

C
D

¹⁾ Selection depends on the concrete startup and rated data of the protected motor.

For Operation in the Control Cabinet

SIRIUS 3RA1 load feeders

3RA12 reversing starters for snapping onto standard mounting rails or for screw mounting

Selection and ordering data



3RA12 10



3RA12 20

Reversing duty

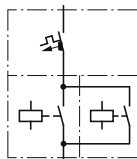

Rated control supply voltage 50 Hz 230 V AC¹⁾ for TH 35 standard mounting rail or screw mounting

- The motor starter protector and contactor are mechanically and electrically connected by means of the link module
- As from size S0 with standard mounting rail adapter²⁾ for mechanical reinforcement
- Auxiliary switches³⁾ on the motor starter protector and the contactor can be easily fitted due to the modular system
- Complete unit always with electrical and mechanical interlock

Size	Standard induction motor 4-pole at 400 V AC ⁴⁾		Setting range for thermal overload release	Consisting of the following single devices			DT	Fuseless load feeders	T _{OC} 2	PU (UNIT, SET, M)	PS*	PG
	Standard output P	Motor current I (guide value)		Motor starter protectors	+ 2 contactors	+ Link module + Assembly kit RH ²⁾⁵⁾						
	kW	A	A									

Type of coordination "2" at I_q = 50 kA/100 kA at 400 V (compatible with type of coordination "1")⁶⁾

				3RV10	3RT10	3RA19						
S00	0,06	0,2	0,14 ... 0,2	11-0BA10	15-1AP02	11-1AA00	A	3RA12 10-0BA15-0APO	1	1 unit	41D	
	0,06	0,2	0,18 ... 0,25	11-0CA10		+	A	3RA12 10-0CA15-0APO	1	1 unit	41D	
	0,09	0,3	0,22 ... 0,32	11-0DA10		13-2A ⁷⁾	A	3RA12 10-0DA15-0APO	1	1 unit	41D	
	0,09	0,3	0,28 ... 0,4	11-0EA10			A	3RA12 10-0EA15-0APO	1	1 unit	41D	
	0,12	0,4	0,35 ... 0,5	11-0FA10			A	3RA12 10-0FA15-0APO	1	1 unit	41D	
	0,18	0,6	0,45 ... 0,63	11-0GA10			A	3RA12 10-0GA15-0APO	1	1 unit	41D	
	0,18	0,6	0,55 ... 0,8	11-0HA10			A	3RA12 10-0HA15-0APO	1	1 unit	41D	
	0,25	0,85	0,7 ... 1	11-0JA10			A	3RA12 10-0JA15-0APO	1	1 unit	41D	
	0,37	1,1	0,9 ... 1,25	11-0KA10			A	3RA12 10-0KA15-0APO	1	1 unit	41D	
	0,55	1,5	1,1 ... 1,6	11-1AA10			A	3RA12 10-1AA15-0APO	1	1 unit	41D	
	0,75	1,9	1,4 ... 2	11-1BA10			A	3RA12 10-1BA15-0APO	1	1 unit	41D	
S0	0,75	1,9	1,8 ... 2,5	21-1CA10	24-1AP00	21-1AA00	A	3RA12 20-1CB24-0APO	1	1 unit	41D	
	1,1	2,7	2,2 ... 3,2	21-1DA10		+	A	3RA12 20-1DB24-0APO	1	1 unit	41D	
	1,5	3,6	2,8 ... 4	21-1EA10		23-1B ⁸⁾	A	3RA12 20-1EB24-0APO	1	1 unit	41D	
	1,5	3,6	3,5 ... 5	21-1FA10			A	3RA12 20-1FB24-0APO	1	1 unit	41D	
	2,2	4,9	4,5 ... 6,3	21-1GA10			A	3RA12 20-1GB24-0APO	1	1 unit	41D	
	3	6,5	5,5 ... 8	21-1HA10			A	3RA12 20-1HB24-0APO	1	1 unit	41D	
	4	8,5	7 ... 10	21-1JA10	26-1AP00		A	3RA12 20-1JB26-0APO	1	1 unit	41D	
	5,5	11,5	9 ... 12,5	21-1KA10			A	3RA12 20-1KB26-0APO	1	1 unit	41D	
	7,5	15,5	11 ... 16	21-4AA10			A	3RA12 20-4AB26-0APO	1	1 unit	41D	
	7,5	15,5	14 ... 20	21-4BA10			A	3RA12 20-4BB26-0APO	1	1 unit	41D	
S2	11	22	18 ... 25	31-4DA10	34-1AP00	31-1AA00		Size S2 is only available for self-assembly.				
	15	29	22 ... 32	31-4EA10		+						
	18,5	35	28 ... 40	31-4FA10	35-1AP00	33-1B ⁸⁾						
	22	41	36 ... 45	31-4GA10	36-1AP00							
	22	41	40 ... 50	31-4HA10								
S3	30	55	45 ... 63	41-4JA10	44-1AP00	41-1AA00		Size S3 is only available for self-assembly.				
	37	66	57 ... 75	41-4KA10	45-1AP00	+						
	45	80	70 ... 90	41-4LA10	46-1AP00	43-1B ⁸⁾						
	45	80	80 ... 100	41-4MA10								

¹⁾ Size S00 also suitable for 60 Hz.

²⁾ Assembly kit for standard mounting rail adapter also suitable for screw mounting.

³⁾ Auxiliary switches see "Accessories for Direct-On-Line and Reversing Starters".

⁴⁾ Selection depends on the concrete startup and rated data of the protected motor.

⁵⁾ RH = Reversing duty for standard rail mounting.

⁶⁾ Load feeders with I_q ≥ 100 kA see notes on "Technical Information" on page 8.



⁷⁾ Wiring kit necessary: for screw mounting with 1 push-in lug each per load feeder (see "Accessories for Direct-On-Line and Reversing Starters").

⁸⁾ Mechanical locking device must be ordered separately (see "Accessories for Direct-On-Line and Reversing Starters").

For Operation in the Control Cabinet

SIRIUS 3RA1 load feeders

3RA12 reversing starters for snapping onto standard mounting rails or for screw mounting

Size	Standard induction motor 4-pole at 400 V AC ¹⁾		Setting range for thermal overload release 	Consisting of the following single devices			DT	Fuseless load feeders 	PU (UNIT, SET, M)	PS*	PG
	Standard output P	Motor current I (guide value)		Motor starter protectors	+ 2 con-tactors	+ Link module + Assembly kit RH ²⁾³⁾					
	kW	A	A								
Type of coordination "1" at $I_q = 50$ kA at 400 V⁴⁾ (the motor starter protector is compatible with type of coordination "2")											
S00	0,75	1,9	1,4 ... 2								For load feeders for lower outputs, see table above (type of coordination "2").
				3RV10	3RT10	3RA19					
S00	0,75	1,9	1,8 ... 2,5	11-1CA10	15-1AP02	11-1AA00	A	3RA12 10-1CA15-0AP0	1	1 unit	41D
	1,1	2,7	2,2 ... 3,2	11-1DA10		+	A	3RA12 10-1DA15-0AP0	1	1 unit	41D
	1,5	3,6	2,8 ... 4	11-1EA10		13-2A ⁵⁾	A	3RA12 10-1EA15-0AP0	1	1 unit	41D
	1,5	3,6	3,5 ... 5	11-1FA10			A	3RA12 10-1FA15-0AP0	1	1 unit	41D
	2,2	4,9	4,5 ... 6,3	11-1GA10			A	3RA12 10-1GA15-0AP0	1	1 unit	41D
	3	6,5	5,5 ... 8	11-1HA10			A	3RA12 10-1HA15-0AP0	1	1 unit	41D
	4	8,5	7 ... 10	11-1JA10	16-1AP02		A	3RA12 10-1JA16-0AP0	1	1 unit	41D
	5,5	11,5	9 ... 12	11-1KA10	17-1AP02		A	3RA12 10-1KA17-0AP0	1	1 unit	41D
S0	7,5	15,5	11 ... 16	21-4AA10	25-1AP00	21-1AA00	A	3RA12 20-4AB25-0AP0	1	1 unit	41D
	7,5	15,5	14 ... 20	21-4BA10		+	A	3RA12 20-4BB25-0AP0	1	1 unit	41D
	11	22	17 ... 22	21-4CA10	26-1AP00	23-1B ⁶⁾	A	3RA12 20-4CB26-0AP0	1	1 unit	41D
	11	22	20 ... 25	21-4DA10			A	3RA12 20-4DB26-0AP0	1	1 unit	41D
S2	15	29	22 ... 32								For load feeders for higher outputs, see table above (type of coordination "2").
	18,5	35	28 ... 40								
	22	41	36 ... 45								
			...								

¹⁾ Selection depends on the concrete startup and rated data of the protected motor.

²⁾ Assembly kit for standard mounting rail adapter also suitable for screw mounting.

³⁾ RH = Reversing duty for standard rail mounting.

⁴⁾ Load feeders with $I_q \geq 100$ kA see notes on "Technical Information" on page 8.

⁵⁾ Wiring kit necessary: for screw mounting with 1 push-in lug each per load feeder (see "Accessories for Direct-On-Line and Reversing Starters").

⁶⁾ Mechanical locking device must be ordered separately (see "Accessories for Direct-On-Line and Reversing Starters").

For Operation in the Control Cabinet

SIRIUS 3RA1 load feeders

3RA12 reversing starters for snapping onto standard mounting rails or for screw mounting



3RA12 10



3RA12 20

Reversing duty

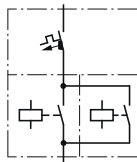

Rated control supply voltage 24 V DC for TH 35 standard mounting rail or screw mounting

- The motor starter protector and contactor are mechanically and electrically connected by means of the link module
- As from size S0 with standard mounting rail adapter¹⁾ for mechanical reinforcement
- Auxiliary switches²⁾ on the motor starter protector and the contactor can be easily fitted due to the modular system
- Complete unit always with electrical and mechanical interlock

Size	Standard induction motor 4-pole at 400 V AC ³⁾	Setting range for thermal overload release	Consisting of the following single devices			DT	Fuseless load feeders	$T_{\text{OC}} 2$	PU (UNIT, SET, M)	PS*	PG
	Standard output P kW	Motor current I (guide value) A	Motor starter protectors	+ 2 contactors	+ Link module + Assembly kit RH ⁴⁾		Order No.	Price € per PU			

Type of coordination "2" at $I_q = 50 \text{ kA}/100 \text{ kA}$ at 400 V (compatible with type of coordination "1")⁵⁾

	3RV10			3RT10		3RA19					
S00	0,06	0,2	0,14 ... 0,2	11-0BA10	15-1BB42	11-1AA00	A	3RA12 10-0BA15-0BB4	1	1 unit	41D
	0,06	0,2	0,18 ... 0,25	11-0CA10		+	A	3RA12 10-0CA15-0BB4	1	1 unit	41D
	0,09	0,3	0,22 ... 0,32	11-0DA10		13-2A ⁶⁾	A	3RA12 10-0DA15-0BB4	1	1 unit	41D
	0,09	0,3	0,28 ... 0,4	11-0EA10			A	3RA12 10-0EA15-0BB4	1	1 unit	41D
	0,12	0,4	0,35 ... 0,5	11-0FA10			A	3RA12 10-0FA15-0BB4	1	1 unit	41D
	0,18	0,6	0,45 ... 0,63	11-0GA10			A	3RA12 10-0GA15-0BB4	1	1 unit	41D
	0,18	0,6	0,55 ... 0,8	11-0HA10			A	3RA12 10-0HA15-0BB4	1	1 unit	41D
	0,25	0,85	0,7 ... 1	11-0JA10			A	3RA12 10-0JA15-0BB4	1	1 unit	41D
	0,37	1,1	0,9 ... 1,25	11-0KA10			A	3RA12 10-0KA15-0BB4	1	1 unit	41D
	0,55	1,5	1,1 ... 1,6	11-1AA10			A	3RA12 10-1AA15-0BB4	1	1 unit	41D
	0,75	1,9	1,4 ... 2	11-1BA10			A	3RA12 10-1BA15-0BB4	1	1 unit	41D
S0	0,75	1,9	1,8 ... 2,5	21-1CA10	24-1BB40	21-1BA00	A	3RA12 20-1CB24-0BB4	1	1 unit	41D
	1,1	2,7	2,2 ... 3,2	21-1DA10		+	A	3RA12 20-1DB24-0BB4	1	1 unit	41D
	1,5	3,6	2,8 ... 4	21-1EA10		23-1B ⁷⁾	A	3RA12 20-1EB24-0BB4	1	1 unit	41D
	1,5	3,6	3,5 ... 5	21-1FA10			A	3RA12 20-1FB24-0BB4	1	1 unit	41D
	2,2	4,9	4,5 ... 6,3	21-1GA10			A	3RA12 20-1GB24-0BB4	1	1 unit	41D
	3	6,5	5,5 ... 8	21-1HA10			A	3RA12 20-1HB24-0BB4	1	1 unit	41D
	4	8,5	7 ... 10	21-1JA10	26-1BB40		A	3RA12 20-1JB26-0BB4	1	1 unit	41D
	5,5	11,5	9 ... 12,5	21-1KA10			A	3RA12 20-1KB26-0BB4	1	1 unit	41D
	7,5	15,5	11 ... 16	21-4AA10			A	3RA12 20-4AB26-0BB4	1	1 unit	41D
	7,5	15,5	14 ... 20	21-4BA10			A	3RA12 20-4BB26-0BB4	1	1 unit	41D
S2	11	22	18 ... 25	31-4DA10	34-1BB40	31-1BA00		Size S2 is only available for self-assembly.			
	15	29	22 ... 32	31-4EA10		+					
	18,5	35	28 ... 40	31-4FA10	35-1BB40	33-1B ⁷⁾					
	22	41	36 ... 45	31-4GA10	36-1BB40						
	22	41	40 ... 50	31-4HA10							
S3	30	55	45 ... 63	41-4JA10	44-1BB40	41-1BA00		Size S3 is only available for self-assembly.			
	37	66	57 ... 75	41-4KA10	45-1BB40	+					
	45	80	70 ... 90	41-4LA10	46-1BB40	43-1B ⁷⁾					
	45	80	80 ... 100	41-4MA10							

¹⁾ Assembly kit for standard mounting rail adapter also suitable for screw mounting.

²⁾ Auxiliary switches see "Accessories for Direct-On-Line and Reversing Starters".

³⁾ Selection depends on the concrete startup and rated data of the protected motor.

⁴⁾ RH = Reversing duty for standard rail mounting.

⁵⁾ Load feeders with $I_q \geq 100 \text{ kA}$ see notes on "Technical Information" on page 8.



⁶⁾ Wiring kit necessary: Screw mounting with 1 push-in lug each per load feeder is possible (see "Accessories for Direct-On-Line and Reversing Starters").

⁷⁾ Mechanical locking device must be ordered separately (see "Accessories for Direct-On-Line and Reversing Starters").

For Operation in the Control Cabinet

SIRIUS 3RA1 load feeders

3RA12 reversing starters for snapping onto standard mounting rails or for screw mounting

Size	Standard induction motor 4-pole at 400 V AC ¹⁾		Setting range for thermal overload release 	Consisting of the following single devices			DT	Fuseless load feeders 		PU (UNIT, SET, M)	PS*	PG
	Standard output P	Motor current I (guide value)		Motor starter protectors	+ 2 con-tactors	+ Link module + Assembly kit RH ²⁾³⁾		Order No.	Price € per PU			
	kW	A	A									
Type of coordination "1" at $I_q = 50 \text{ kA}$ at 400 V⁴⁾ (the motor starter protector is compatible with type of coordination "2")												
S00	0,75	1,9	1,4 ... 2									For load feeders for lower outputs, see table above (type of coordination "2").
				3RV10	3RT10	3RA19						
S00	0,75	1,9	1,8 ... 2,5	11-1CA10	15-1BB42	11-1AA00	A	3RA12 10-1CA15-0BB4		1	1 unit	41D
	1,1	2,7	2,2 ... 3,2	11-1DA10		+	A	3RA12 10-1DA15-0BB4		1	1 unit	41D
	1,5	3,6	2,8 ... 4	11-1EA10			A	3RA12 10-1EA15-0BB4		1	1 unit	41D
	1,5	3,6	3,5 ... 5	11-1FA10			A	3RA12 10-1FA15-0BB4		1	1 unit	41D
	2,2	4,9	4,5 ... 6,3	11-1GA10			A	3RA12 10-1GA15-0BB4		1	1 unit	41D
	3	6,5	5,5 ... 8	11-1HA10			A	3RA12 10-1HA15-0BB4		1	1 unit	41D
	4	8,5	7 ... 10	11-1JA10	16-1BB42		A	3RA12 10-1JA16-0BB4		1	1 unit	41D
	5,5	11,5	9 ... 12	11-1KA10	17-1BB42		A	3RA12 10-1KA17-0BB4		1	1 unit	41D
S0	7,5	15,5	11 ... 16	21-4AA10	25-1BB40	21-1BA00	A	3RA12 20-4AB25-0BB4		1	1 unit	41D
	7,5	15,5	14 ... 20	21-4BA10		+	A	3RA12 20-4BB25-0BB4		1	1 unit	41D
	11	22	17 ... 22	21-4CA10	26-1BB40	23-1B ⁶⁾	A	3RA12 20-4CB26-0BB4		1	1 unit	41D
	11	22	20 ... 25	21-4DA10			A	3RA12 20-4DB26-0BB4		1	1 unit	41D
S2	15	29	22 ... 32									For load feeders for higher outputs, see table above (type of coordination "2").
	18,5	35	28 ... 40									
	22	41	36 ... 45									

1) Selection depends on the concrete startup and rated data of the protected motor.

2) Assembly kit for standard mounting rail adapter also suitable for screw mounting.

3) RH = Reversing duty for standard rail mounting.

4) Load feeders with $I_q \geq 100 \text{ kA}$ see notes on "Technical Information" on page 8.

5) Wiring kit necessary: Screw mounting with 1 push-in lug each per load feeder is possible (see "Accessories for Direct-On-Line and Reversing Starters").

6) Mechanical locking device must be ordered separately (see "Accessories for Direct-On-Line and Reversing Starters").

For Operation in the Control Cabinet

SIRIUS 3RA1 load feeders

3RA12 reversing starters for busbar systems

Selection and ordering data

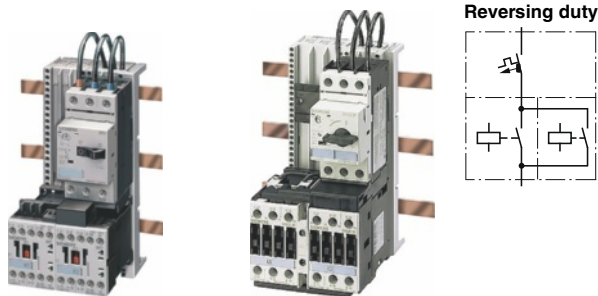

Rated control supply voltage 50 Hz 230 V AC¹⁾ for 40 and 60 mm busbar systems

- The motor starter protector and contactor are mechanically and electrically connected by means of the link module
- Auxiliary switches²⁾ on the motor starter protector and the contactor can be easily fitted due to the modular system
- Complete unit always with electrical and mechanical interlock

Size	Standar induction motor 4-pole at 400 V AC ³⁾	Setting range for thermal overload releas	Consisting of the following single devices			DT	Fuseless load feeders	PU (UNIT, SET, M)	PS*	PG
	Standard output P kW	Motor current I (guide value) A	Motor starter protectors	+ 2 con-tactors	+ Link module + Assembly kit RS ⁴⁾		Order No.	Price € per PU		

Type of coordination "2" at I_q = 50 kA at 400 V (compatible with type of coordination "1")

	3RV10			3RT10		3RA19					
S00	0,06	0,2	0,14 ... 0,2	11-0BA10	15-1AP02	11-1AA00	A	3RA12 10-0B□15-0AP0	1	1 unit	41D
	0,06	0,2	0,18 ... 0,25	11-0CA10		+	A	3RA12 10-0C□15-0AP0	1	1 unit	41D
	0,09	0,3	0,22 ... 0,32	11-0DA10		40 mm:	A	3RA12 10-0D□15-0AP0	1	1 unit	41D
	0,09	0,3	0,28 ... 0,4	11-0EA10		13-1C	A	3RA12 10-0E□15-0AP0	1	1 unit	41D
	0,12	0,4	0,35 ... 0,5	11-0FA10		or 60 mm:	A	3RA12 10-0F□15-0AP0	1	1 unit	41D
	0,18	0,6	0,45 ... 0,63	11-0GA10		13-1D	A	3RA12 10-0G□15-0AP0	1	1 unit	41D
	0,18	0,6	0,55 ... 0,8	11-0HA10			A	3RA12 10-0H□15-0AP0	1	1 unit	41D
	0,25	0,85	0,7 ... 1	11-0JA10			A	3RA12 10-0J□15-0AP0	1	1 unit	41D
	0,37	1,1	0,9 ... 1,25	11-0KA10			A	3RA12 10-0K□15-0AP0	1	1 unit	41D
	0,55	1,5	1,1 ... 1,6	11-1AA10			A	3RA12 10-1A□15-0AP0	1	1 unit	41D
	0,75	1,9	1,4 ... 2	11-1BA10			A	3RA12 10-1B□15-0AP0	1	1 unit	41D
S0	0,75	1,9	1,8 ... 2,5	21-1CA10	24-1AP00	21-1AA00	A	3RA12 20-1C□24-0AP0	1	1 unit	41D
	1,1	2,7	2,2 ... 3,2	21-1DA10		+	A	3RA12 20-1D□24-0AP0	1	1 unit	41D
	1,5	3,6	2,8 ... 4	21-1EA10		40 mm:	A	3RA12 20-1E□24-0AP0	1	1 unit	41D
	1,5	3,6	3,5 ... 5	21-1FA10		23-1C ⁵⁾	A	3RA12 20-1F□24-0AP0	1	1 unit	41D
	2,2	4,9	4,5 ... 6,3	21-1GA10		or 60 mm:	A	3RA12 20-1G□24-0AP0	1	1 unit	41D
	3	6,5	5,5 ... 8	21-1HA10		23-1D ⁵⁾	A	3RA12 20-1H□24-0AP0	1	1 unit	41D
	4	8,5	7 ... 10	21-1JA10	26-1AP00		A	3RA12 20-1J□26-0AP0	1	1 unit	41D
	5,5	11,5	9 ... 12,5	21-1KA10			A	3RA12 20-1K□26-0AP0	1	1 unit	41D
	7,5	15,5	11 ... 16	21-4AA10			A	3RA12 20-4A□26-0AP0	1	1 unit	41D
	7,5	15,5	14 ... 20	21-4BA10			A	3RA12 20-4B□26-0AP0	1	1 unit	41D
S2	11	22	18 ... 25	31-4DA10	34-1AP00	31-1AA00		Size S2 is only available for self-assembly.			
	15	29	22 ... 32	31-4EA10		+					
	18,5	35	28 ... 40	31-4FA10	35-1AP00	40 mm:					
	22	41	36 ... 45	31-4GA10	36-1AP00	33-1C ⁵⁾					
	22	41	40 ... 50	31-4HA10		or 60 mm:					
						33-1D ⁵⁾					
S3	30	55	45 ... 63	41-4JA10	44-1AP00	41-1AA00		For size S3, a busbar adapter is not necessary.			
	37	66	57 ... 75	41-4KA10	45-1AP00	+					
	45	80	70 ... 90	41-4LA10	46-1AP00	not available					
	45	80	80 ... 100	41-4MA10							

Order No. supplement for busbar center-to-center spacing

- 40 mm
- 60 mm

C
D

1) Size S00 also suitable for 60 Hz.
 2) Auxiliary switches see "Accessories for Direct-On-Line and Reversing Starters".
 3) Selection depends on the concrete startup and rated data of the protected motor.
 4) RS = Reversing duty for busbar systems.
 5) Mechanical locking device must be ordered separately (see "Accessories for Direct-On-Line and Reversing Starters").

For Operation in the Control Cabinet

SIRIUS 3RA1 load feeders

3RA12 reversing starters for busbar systems

Size	Standard induction motor 4-pole at 400 V AC ¹⁾		Setting range for thermal overload release 	Consisting of the following single devices			DT	Fuseless load feeders 1		PU (UNIT, SET, M)	PS*	PG
	Standard output P	Motor current I (guide value)		Motor starter protectors	+ 2 con-tactors	+ Link module + Assembly kit RS ²⁾		Order No.	Price € per PU			
	kW	A	A									
Type of coordination "1" at I_q = 50 kA at 400 V (the motor starter protector is compatible with type of coordination "2")												
S00	0,75	1,9	1,4 ... 2									For load feeders for lower outputs, see table above (type of coordination "2").
				3RV10	3RT10	3RA19						
S00	0,75	1,9	1,8 ... 2,5	11-1CA10	15-1AP02	11-1AA00	A	3RA12 10-1C □15-0AP0		1	1 unit	41D
	1,1	2,7	2,2 ... 3,2	11-1DA10		+	A	3RA12 10-1D □15-0AP0		1	1 unit	41D
	1,5	3,6	2,8 ... 4	11-1EA10		40 mm:	A	3RA12 10-1E □15-0AP0		1	1 unit	41D
	1,5	3,6	3,5 ... 5	11-1FA10		13-1C	A	3RA12 10-1F □15-0AP0		1	1 unit	41D
	2,2	4,9	4,5 ... 6,3	11-1GA10		or 60 mm:	A	3RA12 10-1G □15-0AP0		1	1 unit	41D
	3	6,5	5,5 ... 8	11-1HA10		13-1D	A	3RA12 10-1H □15-0AP0		1	1 unit	41D
	4	8,5	7 ... 10	11-1JA10	16-1AP02		A	3RA12 10-1J □16-0AP0		1	1 unit	41D
	5,5	11,5	9 ... 12	11-1KA10	17-1AP02		A	3RA12 10-1K □17-0AP0		1	1 unit	41D
S0	7,5	15,5	11 ... 16	21-4AA10	25-1AP00	21-1AA00	A	3RA12 20-4A □25-0AP0		1	1 unit	41D
	7,5	15,5	14 ... 20	21-4BA10		+	A	3RA12 20-4B □25-0AP0		1	1 unit	41D
	11	22	17 ... 22	21-4CA10	26-1AP00	40 mm:	A	3RA12 20-4C □26-0AP0		1	1 unit	41D
	11	22	20 ... 25	21-4DA10		23-1C ³⁾	A	3RA12 20-4D □26-0AP0		1	1 unit	41D
						or 60 mm:						
						23-1D ³⁾						
S2	15	29	22 ... 32									For load feeders for higher outputs, see table above (type of coordination "2").
	18,5	35	28 ... 40									
	22	41	36 ... 45									
			...									

Order No. supplement for busbar center-to-center spacing

40 mm
60 mm

C
D

- 1) Selection depends on the concrete startup and rated data of the protected motor.
- 2) RS = Reversing duty for busbar systems.
- 3) Mechanical locking device must be ordered separately (see "Accessories for Direct-On-Line and Reversing Starters").



For Operation in the Control Cabinet

SIRIUS 3RA1 load feeders

3RA12 reversing starters for busbar systems

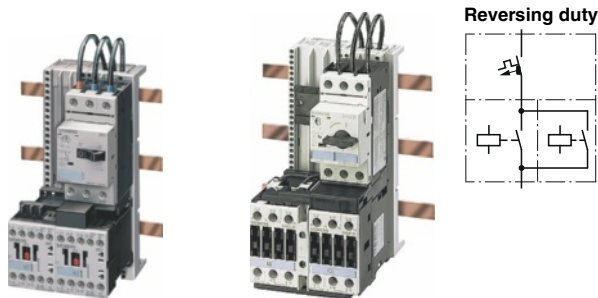

Rated control supply voltage 24 V DC for 40 and 60 mm busbar systems

- The motor starter protector and contactor are mechanically and electrically connected by means of the link module
- Auxiliary switches¹⁾ on the motor starter protector and the contactor can be easily fitted due to the modular system
- Complete unit always with electrical and mechanical interlock

Size	Standard induction motor 4-pole at 400 V AC ²⁾	Setting range for thermal overload release	Consisting of the following single devices	DT	Fuseless load feeders	T _{9C} 2	PU (UNIT, SET, M)	PS*	PG
	Standard output P kW	Motor current I (guide value) A	Motor starter protectors + 2 contactors + Link module + Assembly kit RS ³⁾		Order No.	Price € per PU			

Type of coordination "2" at I_q = 50 kA at 400 V (compatible with type of coordination "1")

			3RV10	3RT10	3RA19						
S00	0,06	0,2	0,14 ... 0,2	11-0BA10	15-1BB42	11-1AA00	A	3RA12 10-0B □15-0BB4	1	1 unit	41D
	0,06	0,2	0,18 ... 0,25	11-0CA10		+	A	3RA12 10-0C □15-0BB4	1	1 unit	41D
	0,09	0,3	0,22 ... 0,32	11-0DA10		40 mm:	A	3RA12 10-0D □15-0BB4	1	1 unit	41D
	0,09	0,3	0,28 ... 0,4	11-0EA10		13-1C	A	3RA12 10-0E □15-0BB4	1	1 unit	41D
	0,12	0,4	0,35 ... 0,5	11-0FA10		or 60 mm:	A	3RA12 10-0F □15-0BB4	1	1 unit	41D
	0,18	0,6	0,45 ... 0,63	11-0GA10		13-1D	A	3RA12 10-0G □15-0BB4	1	1 unit	41D
	0,18	0,6	0,55 ... 0,8	11-0HA10			A	3RA12 10-0H □15-0BB4	1	1 unit	41D
	0,25	0,85	0,7 ... 1	11-0JA10			A	3RA12 10-0J □15-0BB4	1	1 unit	41D
	0,37	1,1	0,9 ... 1,25	11-0KA10			A	3RA12 10-0K □15-0BB4	1	1 unit	41D
	0,55	1,5	1,1 ... 1,6	11-1AA10			A	3RA12 10-1A □15-0BB4	1	1 unit	41D
	0,75	1,9	1,4 ... 2	11-1BA10			A	3RA12 10-1B □15-0BB4	1	1 unit	41D
	S0	0,75	1,9	1,8 ... 2,5	21-1CA10	24-1BB40	21-1BA00	A	3RA12 20-1C □24-0BB4	1	1 unit
1,1		2,7	2,2 ... 3,2	21-1DA10		+	A	3RA12 20-1D □24-0BB4	1	1 unit	41D
1,5		3,6	2,8 ... 4	21-1EA10		40 mm:	A	3RA12 20-1E □24-0BB4	1	1 unit	41D
1,5		3,6	3,5 ... 5	21-1FA10		23-1C ⁴⁾	A	3RA12 20-1F □24-0BB4	1	1 unit	41D
2,2		4,9	4,5 ... 6,3	21-1GA10		or 60 mm:	A	3RA12 20-1G □24-0BB4	1	1 unit	41D
3		6,5	5,5 ... 8	21-1HA10		23-1D ⁴⁾	A	3RA12 20-1H □24-0BB4	1	1 unit	41D
4		8,5	7 ... 10	21-1JA10	26-1BB40		A	3RA12 20-1J □26-0BB4	1	1 unit	41D
5,5		11,5	9 ... 12,5	21-1KA10			A	3RA12 20-1K □26-0BB4	1	1 unit	41D
7,5		15,5	11 ... 16	21-4AA10			A	3RA12 20-4A □26-0BB4	1	1 unit	41D
7,5		15,5	14 ... 20	21-4BA10			A	3RA12 20-4B □26-0BB4	1	1 unit	41D
S2	11	22	18 ... 25	31-4DA10	34-1BB40	31-1BA00			Size S2 is only available for self-assembly.		
	15	29	22 ... 32	31-4EA10		+					
	18,5	35	28 ... 40	31-4FA10	35-1BB40	40 mm:					
	22	41	36 ... 45	31-4GA10	36-1BB40	33-1C ⁴⁾					
	22	41	40 ... 50	31-4HA10		or 60 mm:					
S3	30	55	45 ... 63	41-4JA10	44-1BB40	41-1BA00			For size S3, a busbar adapter is not necessary.		
	37	66	57 ... 75	41-4KA10	45-1BB40	+					
	45	80	70 ... 90	41-4LA10	46-1BB40	not available					
	45	80	80 ... 100	41-4MA10							

Order No. supplement for busbar center-to-center spacing

40 mm
60 mm

- 1) Auxiliary switches see "Accessories for Direct-On-Line and Reversing Starters".
- 2) Selection depends on the concrete startup and rated data of the protected motor.
- 3) RS = Reversing duty for busbar systems.
- 4) Mechanical locking device must be ordered separately (see "Accessories for Direct-On-Line and Reversing Starters").

C
D

For Operation in the Control Cabinet

SIRIUS 3RA1 load feeders

3RA12 reversing starters for busbar systems

Size	Standard induction motor 4-pole at 400 V AC ¹⁾		Setting range for thermal overload release 	Consisting of the following single devices			DT	Fuseless load feeders		PU (UNIT, SET, M)	PS*	PG
	Standard output P	Motor current I (guide value)		Motor starter protectors	+ 2 con-tactors	+ Link module + Assembly kit RS ²⁾		Order No.	Price € per PU			
	kW	A	A									
Type of coordination "1" at $I_q = 50$ kA at 400 V (the motor starter protector is compatible with type of coordination "2")												
S00	0,75	1,9	1,4 ... 2									For load feeders for lower outputs, see table above (type of coordination "2").
				3RV10	3RT10	3RA19						
S00	0,75	1,9	1,8 ... 2,5	11-1CA10	15-1BB42	11-1AA00	A	3RA12 10-1C □15-0BB4		1	1 unit	41D
	1,1	2,7	2,2 ... 3,2	11-1DA10		+	A	3RA12 10-1D □15-0BB4		1	1 unit	41D
	1,5	3,6	2,8 ... 4	11-1EA10		40 mm:	A	3RA12 10-1E □15-0BB4		1	1 unit	41D
	1,5	3,6	3,5 ... 5	11-1FA10		13-1C	A	3RA12 10-1F □15-0BB4		1	1 unit	41D
	2,2	4,9	4,5 ... 6,3	11-1GA10		or 60 mm:	A	3RA12 10-1G □15-0BB4		1	1 unit	41D
	3	6,5	5,5 ... 8	11-1HA10		13-1D	A	3RA12 10-1H □15-0BB4		1	1 unit	41D
	4	8,5	7 ... 10	11-1JA10	16-1BB42		A	3RA12 10-1J □16-0BB4		1	1 unit	41D
	5,5	11,5	9 ... 12	11-1KA10	17-1BB42		A	3RA12 10-1K □17-0BB4		1	1 unit	41D
S0	7,5	15,5	11 ... 16	21-4AA10	25-1BB40	21-1BA00	A	3RA12 20-4A □25-0BB4		1	1 unit	41D
	7,5	15,5	14 ... 20	21-4BA10		+	A	3RA12 20-4B □25-0BB4		1	1 unit	41D
	11	22	17 ... 22	21-4CA10	26-1BB40	40 mm:	A	3RA12 20-4C □26-0BB4		1	1 unit	41D
	11	22	20 ... 25	21-4DA10		23-1C ³⁾	A	3RA12 20-4D □26-0BB4		1	1 unit	41D
						or 60 mm:						
						23-1D ³⁾						
S2	15	29	22 ... 32									For load feeders for higher outputs, see table above (type of coordination "2").
	18,5	35	28 ... 40									
	22	41	36 ... 45									
			...									

Order No. supplement for busbar center-to-center spacing

40 mm
60 mm

C
D





- Selection depends on the concrete startup and rated data of the protected motor.
- RS = Reversing duty for busbar systems.
- Mechanical locking device must be ordered separately (see "Accessories for Direct-On-Line and Reversing Starters").

For Operation in the Control Cabinet

SIRIUS 3RA1 load feeders

Accessories for 3RA1 direct-on-line and reversing starters

Selection and ordering data

	For motor starter protectors Size	For con- tactors Size	Version	DT	Order No.	Price € per PU	PU (UNIT, SET, M)	PS*	PG	
Motor starter protectors¹⁾										
 3RV19 01-1E	S00 ...S3	--	Auxiliary switches							
			Transverse	1 CO contact	▶	3RV19 01-1D	1	1 unit	41E	
			Transverse	1 NO + 1 NC	▶	3RV19 01-1E	1	1 unit	41E	
 3RV19 01-1A	S00 ...S3	--	Laterally mountable	1 NO + 1 NC	▶	3RV19 01-1A	1	1 unit	41E	
 3RV19 02-1...	S00 ...S3	--	Undervoltage releases 50 Hz 230 V AC		▶	3RV19 02-1A0	1	1 unit	41E	
	S00 ...S3	--	Shunt releases 50 Hz 230 V AC		▶	3RV19 02-1DP0	1	1 unit	41E	
Contactors²⁾										
 3RH19 11-1BA..	--	S00	Snap-on auxiliary switch blocks Connection from below	1-pole	1 NO	▶	3RH19 11-1BA10	1	1 unit	41B
					1 NC	▶	3RH19 11-1BA01	1	1 unit	41B
					1 NO + 1 NC	▶	3RH19 11-1MA11	1	1 unit	41B
					2 NO	▶	3RH19 11-1MA20	1	1 unit	41B
					1 NO + 1 NC	▶	3RH19 21-1MA11	1	1 unit	41B
					2 NO	▶	3RH19 21-1MA20	1	1 unit	41B
					2 NC	▶	3RH19 21-1MA02	1	1 unit	41B
 3RH19 11-1F..	--	S00	Connection from 2 sides	4-pole	2 NO + 2 NC	▶	3RH19 11-1FA22	1	1 unit	41B
					1 NO	▶	3RH19 21-1CA10	1	1 unit	41B
					1 NC	▶	3RH19 21-1CA01	1	1 unit	41B
					2 NO + 2 NC	▶	3RH19 21-1FA22	1	1 unit	41B



¹⁾ See also "Protection Equipment: 3RV Motor Starter Protectors".

²⁾ See also "Controls: Contactors and Contactor Assemblies".

For Operation in the Control Cabinet

SIRIUS 3RA1 load feeders

Accessories for 3RA1 direct-on-line and reversing starters

For contactors	Version	Rated control supply voltage U_s ¹⁾	DT	Order No. ²⁾	Price € per PU	PU (UNIT, SET, M)	PS*	PG	
Surge suppressors without LED									
Type									
Size S00									
 3RT19 16-1DG00	For plugging onto the front side of the contactors with and without auxiliary switch blocks								
	3RT1.	Varistor	24 ... 48 V AC 24 ... 70 V DC	▶	3RT19 16-1BB00		1	1 unit	41B
			127 ... 240 V AC 150 ... 250 V DC	A	3RT19 16-1BD00		1	1 unit	41B
	3RT1.	RC elements	24 ... 48 V AC 24 ... 70 V DC	▶	3RT19 16-1CB00		1	1 unit	41B
			127 ... 240 V AC 150 ... 250 V DC	▶	3RT19 16-1CD00		1	1 unit	41B
	3RT1.	Noise suppression diodes	12 ... 250 V DC	▶	3RT19 16-1DG00		1	1 unit	41B
3RT1.	Diode assemblies (diode and Zener diode) for DC operation and short break times	12 ... 250 V DC	▶	3RT19 16-1EH00		1	1 unit	41B	
Size S0									
 3RT19 26-1B.00	For fitting onto the coil terminals at top or bottom								
	3RT10 2	Varistor	24 ... 48 V AC 24 ... 70 V DC	▶	3RT19 26-1BB00		1	1 unit	41B
			127 ... 240 V AC 150 ... 250 V DC	▶	3RT19 26-1BD00		1	1 unit	41B
	3RT10 2	RC elements	24 ... 48 V AC 24 ... 70 V DC	▶	3RT19 26-1CB00		1	1 unit	41B
			127 ... 240 V AC 150 ... 250 V DC	▶	3RT19 26-1CD00		1	1 unit	41B
	3RT10 2	Diode assemblies For DC operation and short break times							
	• Can be plugged in at bottom	24 V DC	▶	3RT19 26-1TR00		1	1 unit	41B	
		30 ... 250 V DC	A	3RT19 26-1TS00		1	1 unit	41B	
Sizes S2 and S3									
 3RT19 36-1C.00	For fitting onto the coil terminals at top or bottom								
	3RT10 3, 3RT10 4	Varistor	24 ... 48 V AC 24 ... 70 V DC	▶	3RT19 26-1BB00		1	1 unit	41B
			127 ... 240 V AC 150 ... 250 V DC	▶	3RT19 26-1BD00		1	1 unit	41B
	3RT10 3, 3RT10 4	RC elements	24 ... 48 V AC 24 ... 70 V DC	▶	3RT19 36-1CB00		1	1 unit	41B
			127 ... 240 V AC 150 ... 250 V DC	▶	3RT19 36-1CD00		1	1 unit	41B
	3RT10 3, 3RT10 4	Diode assemblies For DC operation and short break times							
	• Can be plugged in at bottom	24 V DC	▶	3RT19 36-1TR00		1	1 unit	41B	
		30 ... 250 V DC	B	3RT19 36-1TS00		1	1 unit	41B	







¹⁾ Can be used for AC operation for 50/60 Hz. Please inquire about further voltages.

²⁾ For packs of 10 or 5 units "-Z" and order code "X90" must be added to the Order No.

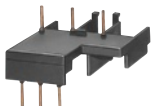
For Operation in the Control Cabinet

SIRIUS 3RA1 load feeders

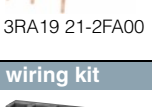
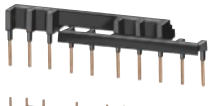
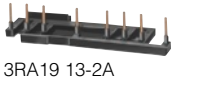



Accessories for 3RA1 direct-on-line and reversing starters

	For motor starter protectors Size	For con- tactors Size	Version	DT	Order No.	Price € per PU	PU (UNIT, SET, M)	PS*	PG
Link modules									
			Electrical and mechanical link between motor starter protector and contactor.						
3RA19 11-1A									
Single-unit packaging									
			Actuating voltage of contactor						
	S00	S00	AC and DC	▶	3RA19 11-1AA00		1	1 unit	41B
	S0	S00		▶	3RA19 21-1DA00		1	1 unit	41B
	S0	S0	AC	▶	3RA19 21-1AA00		1	1 unit	41B
	S2	S2		▶	3RA19 31-1AA00		1	1 unit	41B
	S3	S3		▶	3RA19 41-1AA00		1	1 unit	41B
	S0	S0	DC	▶	3RA19 21-1BA00		1	1 unit	41B
	S2	S2		▶	3RA19 31-1BA00		1	1 unit	41B
	S3	S3		▶	3RA19 41-1BA00		1	1 unit	41B
									
3RA19 21-1A									
Multi-unit packaging									
			Actuating voltage of contactor						
	S00	S00	AC and DC	▶	3RA19 11-1A		1	10 units	41B
	S0	S00		▶	3RA19 21-1D		1	10 units	41B
	S0	S0	AC	▶	3RA19 21-1A		1	10 units	41B
	S2	S2		▶	3RA19 31-1A		1	5 units	41B
	S3	S3		▶	3RA19 41-1A		1	5 units	41B
	S0	S0	DC	▶	3RA19 21-1B		1	10 units	41B
	S2	S2		▶	3RA19 31-1B		1	5 units	41B
	S3	S3		▶	3RA19 41-1B		1	5 units	41B
									
3RA19 31-1A									
Hybrid link modules									
	Screw terminals	Cage Clamp terminals	Electrical and mechanical connection between motor starter protector with screw terminals and contactor with Cage Clamp terminals						
Single-unit packaging									
			Actuating voltage of contactor						
	S00	S00	AC and DC	▶	3RA19 11-2FA00		1	1 unit	41B
	S0	S00		▶	3RA19 21-2FA00		1	1 unit	41B
									
3RA19 21-2FA00									
Multi-unit packaging									
			Actuating voltage of contactor						
	S00	S00	AC and DC	▶	3RA19 11-2F		1	10 units	41B
	S0	S00		▶	3RA19 21-2F		1	10 units	41B
									
3RA19 21-2FA00									
wiring kit									
	--	S00	Reversing duty Electrical and mechanical link for reversing contactors. Can be combined with link module. For size S00: optionally with integrated electrical and mechanical interlocking. For sizes S0 to S3: Mechanical locking device must be ordered separately.	▶	3RA19 13-2A		1	1 unit	41B
		S0		▶	3RA19 23-2A		1	1 unit	41B
		S2		▶	3RA19 33-2A		1	1 unit	41B
		S3		▶	3RA19 43-2A		1	1 unit	41B
									
3RA19 13-2A									
	--	S00	Wye-delta starting Electrical and mechanical link for three contactors of same size	▶	3RA19 13-2B		1	1 unit	41B
		S0		▶	3RA19 23-2B		1	1 unit	41B
		S2		▶	3RA19 33-2B		1	1 unit	41B
		S3		▶	3RA19 43-2B		1	1 unit	41B
									
3RA19 13-2A									
Connection modules for contactors with screw terminals (can be used only for direct-on-line starters)									
		Size S00, S0	Adapters for contactors Ambient temperature $T_{U,max.} = 60\text{ °C}$						
	--	S00	Size S00, rated operational current I_e at AC-3/400 V: 20 A	C	3RT19 16-4RD01		1	1 unit	41B
	--	S0	Size S0, rated operational current I_e at AC-3/400 V: 25 A	C	3RT19 26-4RD01		1	1 unit	41B
									
3RT19 26-4RD01									
	--	S00, S0	Plugs for contactors Size S00, S0	B	3RT19 00-4RE01		1	1 unit	41B
									
3RT19 00-4RE01									

For Operation in the Control Cabinet

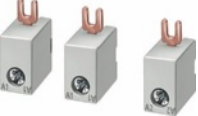
SIRIUS 3RA1 load feeders



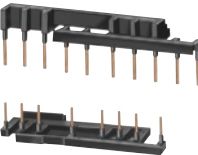

Accessories for 3RA1 direct-on-line and reversing starters

	For motor starter protectors Size	For con- tactors Size	Version	DT	Order No.	Price € per PU	PU (UNIT, SET, M)	PS*	PG
Mechanical interlocks									
	--	S0, S2, S3	For reversing contactors, laterally mountable with 1 auxiliary contact (1 NC) each per contactor.	▶	3RA19 24-2B		1	1 unit	41B
3RA19 24-2B									
Coil repeat terminals									
	--	S0, S2, S3	For A1 and A2 of the reversing contactors (one set consists of 10 x A1 and 5 x A2)	B	3RA19 23-3B		1	1 unit	41B
3RA19 23-3B									
Standard mounting rail adapters									
	Single-unit packaging			▶	3RA19 22-1AA00		1	1 unit	41B
	S00, S0	S00, S0	For mechanical fixing of motor starter protector and contactor	▶	3RA19 32-1AA00		1	1 unit	41B
	S2	S2		▶	3RA19 42-1AA00		1	1 unit	41B
	S3	S3	For snapping onto standard mounting rail or for screw mounting						
	Multi-unit packaging			▶	3RA19 22-1A		1	5 units	41B
	S00, S0	S00, S0	For mechanical fixing of motor starter protector and contactor	▶	3RA19 32-1A		1	5 units	41B
	S2	S2		▶	3RA19 42-1A		1	5 units	41B
	S3	S3	For snapping onto standard mounting rail or for screw mounting						
3RA19 32 3RA19 22									
Side modules									
	S00 ...S3	S00 ...S3	For standard mounting rail adapter 10 mm wide, 96 mm long For widening standard mounting rail adapters. <u>For sizes S00 to S2:</u> 2 units required. <u>For size S3:</u> 3 units required.	▶	3RA19 02-1B		1	10 units	41B
3RA19 02									
Assembly kits (RH) for reversing duty for standard mounting rails									
	S0	S0	Also suitable for screw mounting.	A	3RA19 23-1B		1	1 unit	41B
	S2	S2	Consisting of:	A	3RA19 33-1B		1	1 unit	41B
	S3	S3	Wiring kit, standard mounting rail adapters, side modules. Link modules to be ordered separately. Mechanical locking device to be ordered separately.	A	3RA19 43-1B		1	1 unit	41B
3RA19 33-1B									
									

For Operation in the Control Cabinet

SIRIUS 3RA1 load feeders





Accessories for 3RA1 direct-on-line and reversing starters

	For motor starter protectors Size	For contactors Size	Version	DT	Order No.	Price € per PU	PU (UNIT, SET, M)	PS*	PG
Accessories, adapters and link modules for spring-type terminals									
 3RA19 11-2A + 8US10 51-5CM47	S00	--	Link modules, Cage Clamp Electrical connection between motor starter protector and contactor (1 pack = 10 units)	▶	3RA19 11-2A		1 10 units		41B
	S00	--	Link modules, Cage Clamp with mechanical connections Mechanical and electrical connection between motor starter protector and contactor (1 pack = 10 units)	▶	3RA19 11-2E		1 10 units		41B
		--	Standard mounting rail adapters For Cage Clamp with 2 standard mounting rails, one is movable, 45 mm wide	▶	3RA19 22-1L		1 5 units		41B
		--	Busbar adapters 45 mm wide, 182 mm long, adapted for Cage Clamp motor starter protectors.	▶	8US10 51-5CM47		1 1 unit		143
		--	If there is an additional contactor, a further standard mounting rail must be fitted.	▶	8US12 51-5CM47		1 1 unit		143
 3RA19 11-2E		--	TH 35 standard mounting rails, width 45 mm, plastic, incl. fixing screws (1 pack = 10 units)	A	8US19 98-7CA15		1 10 units		143
	Push-in lugs for screw mounting								
 3RB19 00-0B	S00, S0	--	For 3RV1 motor starter protectors: 2 units each required, for 3RA1 fuseless load feeders: 1 unit each required, for AS-Interface switching device holder: 2 units each required (1 pack = 10 units)	A	3RB19 00-0B		100 10 units		41F
Busbar adapters									
 8US12 51-5DM07	S00, S0	S00, S0	45 mm wide, 182 mm long for busbars	40	▶	8US10 51-5DM07	1	1 unit	143
				60	▶	8US12 51-5DM07	1	1 unit	143
	S2	S2	55 mm wide, 242 mm long including screw and spacer	40	▶	8US10 61-5FP08	1	1 unit	143
				60	▶	8US12 61-5FP08	1	1 unit	143
Device holders									
 8US12 50-5AM00	S00, S0	S00, S0	With standard mounting rail, without connecting cables 45 mm wide, 182 mm long for busbars	40	▶	8US10 50-5AM00	1	1 unit	143
				60	▶	8US12 50-5AM00	1	1 unit	143
	S0	S0	55 mm wide, 182 mm long	40	▶	8US10 60-5AM00	1	1 unit	143
			60	▶	8US12 60-5AM00	1	1 unit	143	
	S2	S2	55 mm wide, 242 mm long including screw and spacer	60	▶	8US12 60-5AP00	1	1 unit	143

For Operation in the Control Cabinet

SIRIUS 3RA1 load feeders

Accessories for 3RA1 direct-on-line and reversing starters

	For motor starter protectors Size	For contactors Size	Version	DT	Order No.	Price € per PU	PU (UNIT, SET, M)	PS*	PG	
Side modules										
	--	--	Including connecting wedges, for widening busbar adapters or device holders, 13.5 mm wide, 182 mm long	A	8US19 98-2BM00		1	4 units	143	
Assembly kits (RS) for reversing duty for 40 mm and 60 mm busbar systems										
				Busbar center-to-center spacing mm						
	S00, S0	S00	Consisting of wiring kit, busbar adapter, device holder, and side module.	40	A	3RA19 13-1C	1	1 unit	41B	
	S0	S0		A		3RA19 23-1C	1	1 unit	41B	
	S00, S0	S00	Link modules and mechanical locking devices to be ordered separately. Only for size S00 is mechanical interlocking always included.	60	A	3RA19 13-1D	1	1 unit	41B	
	S0	S0		A		3RA19 23-1D	1	1 unit	41B	
	S2	S2		A		3RA19 33-1D	1	1 unit	41B	
Connecting wedges										
	--	--	For mechanical linking of busbar adapters and switching device holders or of standard mounting rail adapters (2 units per combination) (1 pack = 100 units)	▶	8US19 98-1AA00		100	100 units	143	
Load-side terminal strips, separable										
	S00, S0	S00, S0	Light gray with carrier for mounting onto busbar adapter 45 mm wide 45 mm wide, 91 mm long 3 x 2.5 mm ² plug-in terminals, 400 V 4 x 1.5 mm ² plug-in terminals, 250 V	A	8US19 98-8AM07		1	1 unit	143	
Spacers										
	--	S00, S0	Fixes the load feeder onto the busbar adapter (1 pack = 100 units)	▶	8US19 98-1BA00		100	100 units	143	
Screw holders										
	--	S00, S0	Allows additional fixing of the feeder with screws (1 pack = 20 units)	B	8US19 98-1CA00		100	20 units	143	
				Version	DT	Order No.	Price € per PU	PU (UNIT, SET, M)	PS*	PG
Documentation										
			Configuration manual (engl.) "SIRIUS Configuration: Selection Data for Fuseless Load Feeders" More information and assignment tables for self-assembly combinations for 400 V, 440 V, 480 V, 500 V, 550 V and 690 V	C	3ZX1012-0RA21-0AC0		1	1 unit	401	

For Operation in the Control Cabinet

SIRIUS 3RA1 load feeders

**3RV19 infeed systems,
SENTRON 8US busbar systems**

Overview

Insulated three-phase busbar system

Three-phase busbar systems provide an easy, time-saving and clearly arranged means of feeding 3RA1 load feeders with screw terminals. Different versions are available for sizes S00, S0 and S2 and can also be used for the various different types of motor starter protectors.

The busbars are suitable for between 2 and 5 feeders. However, any kind of extension is possible by clamping the tags of an additional busbar (rotated by 180°) underneath the terminals of the respective last motor starter protector.

A combination of feeders of different sizes is possible only with sizes S00 and S0. Connecting pieces are available for this purpose. The motor starter protectors are supplied by appropriate feeder terminals.

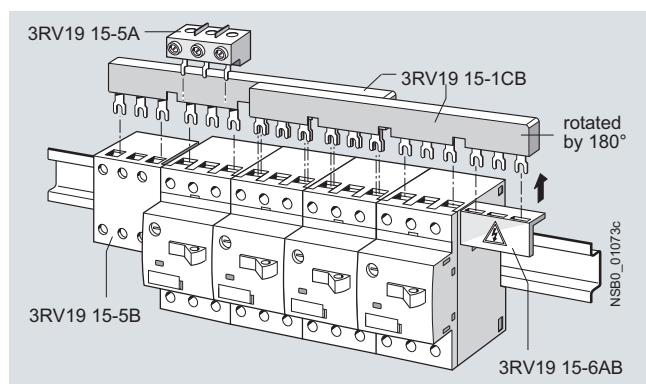

Three-phase busbar system, size S00

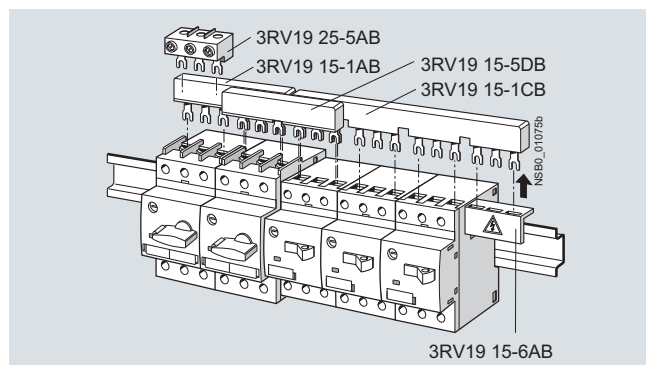

Three-phase busbar system, with example for combining sizes S00 and S0

The three-phase busbar systems are finger-safe. They are designed for any short-circuit stress which can occur at the output side of connected motor starter protectors.

The three-phase busbar systems can also be used to construct "Type E Starters" of size S0 or S2 according to UL/CSA. Special feeder terminals must be used for this purpose however.

For selection and ordering data see Chapter 7, "Protection Equipment, 3RV Motor Starter Protectors up to 100 A, Busbar Accessories".

Busbar adapters for 40 mm and 60 mm systems

The load feeders are mounted directly with the aid of busbar adapters on busbar systems with 40 mm and 60 mm center-to-center spacing in order to save space and to reduce infeed times and costs.

Busbar adapters for busbar systems with 40 mm center-to-center spacing are suitable for copper busbars with a width of 12 mm to 15 mm, while those with 60 mm center-to-center spacing are suitable for copper busbars with a width of 12 mm to 30 mm. The busbars can be 4 to 5 mm or 10 mm thick.

The feeders are snapped onto the adapter and connected on the line side. This prepared unit is then plugged directly onto the busbar system, and is thus connected both mechanically and electrically at the same time.

For selection and ordering data see Chapter 7, "Protection Equipment, 3RV Motor Starter Protectors up to 100 A, Busbar Accessories".

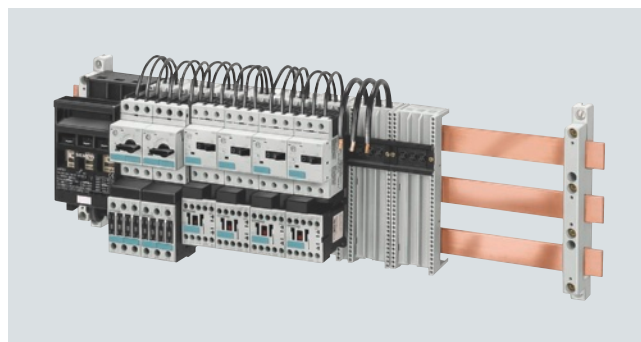

SIRIUS motor starter protectors and load feeders with busbar adapters snapped onto busbars

SIRIUS 3RV19 infeed system

The 3RV19 infeed system is a convenient means of energy supply and distribution for a group of several motor starter protectors or complete load feeders with a screw or spring-type connection up to size S0.

The system is based on a basic module complete with a lateral incoming unit (three-phase busbar with infeed) which has two slots.

Expansion modules are available for extending the system (three-phase busbars for system expansion).



SIRIUS 3RV19 infeed systems with three 3RA1110 load feeders and two 3RA1120 load feeders

3RV19 infeed system see Chapter 7 "Protection Equipment".

Motor Starters for Operation in the Field, High Degree of Protection



9/2

Introduction

SIRIUS 3RE Encapsulated Starters

9/3

General data

9/4

3RE10 direct-on-line starters

9/4

3RE13 reversing starters

More information can be found on the Internet: [see opening information on page 8](#)

Motor Starters for Operation in the Field, High Degree of Protection

Introduction

Overview



3RE10

	Order No.	Page
--	-----------	------

SIRIUS 3RE encapsulated starters

- The 3RE1 encapsulated starters are used for switching and for the inverse-time delayed protection of load feeders up to 22 kW at 400 V AC
- The starters are available as direct-on-line starters for motors with a single direction of rotation and as reversing starters for motors with two directions of rotation

		Order No.	Page
3RE10 direct-on-line starters	<ul style="list-style-type: none"> • Molded-plastic enclosure, degree of protection IP65, including contactor 	3RE10	9/4
3RE13 reversing starters	<ul style="list-style-type: none"> • Molded-plastic enclosure, degree of protection IP65, including contactor assembly 	3RE13	9/4
Accessories	<ul style="list-style-type: none"> • Molded-plastic enclosure, degree of protection IP65, for direct-on-line and reversing starters 	3RE19	9/4

Motor Starters for Operation in the Field, High Degree of Protection

SIRIUS 3RE Encapsulated Starters

General data

Overview



3RE10 10 direct-on-line starter

The 3RE1 encapsulated starters, which are available as direct-on-line starters and as reversing starters, are used for switching and inverse-time delayed overload protection of loads. The switching of loads is taken care by 3RT10 contactors. The protection is achieved with 3RU11 thermal overload relays.

These starter combinations are contained in a molded-plastic enclosure that provides effective protection against dust and splashwater with its high degree of protection IP65. This high degree of protection also applies to the actuators, which are used for manual switching on and off locally.

External fuses (fused design) or motor starter protectors (fuse-less design) are to be used for short-circuit protection.

Direct-on-line starters

The direct-on-line starters are available in three sizes:

- Size **S00** is suitable for induction motors up to 5.5 kW with 400 V AC and a maximum rated motor current of 12 A. The starters are available in the following two versions:
 - Molded-plastic enclosure for direct-on-line starters including contactor – in this case the overload relay must be selected and ordered according to the rated motor current.
 - Molded-plastic enclosure for direct-on-line starters (without contactor) – in this case the contactor and overload relay must be selected and ordered separately.
- Size **S0** is suitable for induction motors up to 11 kW with 400 V AC and a maximum rated motor current of 25 A. The starters are available in the following two versions:
 - Molded-plastic enclosure for direct-on-line starters including contactor – in this case the overload relay must be selected and ordered according to the rated motor current.
 - Molded-plastic enclosure for direct-on-line starters (without contactor) – in this case the contactor, auxiliary switch and overload relay must be selected and ordered separately.
- Size **S2** is suitable for induction motors up to 22 kW with 400 V AC and a maximum rated motor current of 50 A. The starters are available in the following version:
 - Molded-plastic enclosure for direct-on-line starters (without contactor) – in this case the contactor, auxiliary switch and overload relay must be selected and ordered separately.

Reversing starters

The reversing starters are available in two sizes:

- Size **S00** is suitable for induction motors up to 5.5 kW with 400 V AC and a maximum rated motor current of 12 A. The starters are available in the following two versions:
 - Molded-plastic enclosure for reversing starters including contactor assembly – in this case the overload relay must be selected and ordered according to the rated motor current.
 - Molded-plastic enclosure for reversing starters (without contactor assembly) – in this case the contactor assembly, auxiliary switch and overload relay must be selected and ordered separately.
- Size **S0** is suitable for induction motors up to 11 kW with 400 V AC and a maximum rated motor current of 25 A. The starters are available in the following version:
 - Molded-plastic enclosure for direct-on-line starters (without contactor assembly) – in this case the contactor assembly, auxiliary switch and overload relay must be selected and ordered separately.

Benefits

The 3RE1 encapsulated starters are enclosed with a high degree of protection (IP65) and are used for the switching and inverse-time delayed protection of loads. They are ideally suited for implementation directly at the machine.

Application

The 3RE1 encapsulated starters are used for switching and for the inverse-time delayed protection of load feeders up to 22 kW at 400 V AC



The starters are available as direct-on-line starters for motors with a single direction of rotation and as reversing starters for motors with two directions of rotation.

Motor Starters for Operation in the Field, High Degree of Protection

SIRIUS 3RE Encapsulated Starters

3RE10 direct-on-line starters
3RE13 reversing starters



Selection and ordering data

Size	Rated data		Rated control supply voltage U_s		DT	Screw terminals 	PU (UNIT, SET, M)	PS*	PG	
	Utilization category AC-2/AC-3 T_U : up to + 35 °C	Operational current I_e at 400 V	Output of induction motors at 400 V/50 Hz	AC V						At Hz
Direct-on-line starters including contactor										
	S00	12	5,5	230	50 / 60	B	3RE10 10-8XC17-0AP0 3RE10 10-8XC17-0AV0	1	1 unit	41B
		400	50 / 60	B	1	1 unit		41B		
	S0	17	7,5	230	50	B	3RE10 20-8XC25-0AP0 3RE10 20-8XC25-0AV0	1	1 unit	41B
		400	50	B	1	1 unit		41B		
	25	11	230	50	B	3RE10 20-8XC26-0AP0 3RE10 20-8XC26-0AV0	1	1 unit	41B	
		400	50	B	1		1 unit	41B		
Reversing starters including contactor assembly										
	S00	12	5,5	230 AC	50 / 60	B	3RE13 10-8XC17-0AP0 3RE13 10-8XC17-0AV0	1	1 unit	41B
		400 AC	50 / 60	B	1	1 unit		41B		

3RE10 10

3RE13 10

Accessories

Version	For contactor, overload relay	DT	Order No.	Price € per PU	PU (UNIT, SET, M)	PS*	PG
Enclosures for direct-on-line starters							
	Molded-plastic enclosures for surface mounting		Degree of protection IP65, with actuators, with metric cable gland				
	• With PE terminal	S00	B	3RE19 13-1CB1	1	1 unit	41B
	• With N and PE terminals	S0	B	3RE19 23-1CB2	1	1 unit	41B
	• With N and PE terminals	S2	B	3RE19 33-1CB3	1	1 unit	41B
Enclosures for reversing starters							
	Molded-plastic enclosures for surface mounting		Degree of protection IP65, with actuators, with metric cable gland				
	• With N and PE terminals	S00/S0	B	3RE19 13-2CB3	1	1 unit	41B

3RE19 23-1CB2

3RE19 23-2CB3

Industry Automation, Drive Technologies and Low-Voltage Power Distribution

Further information can be obtained from our branch offices listed in the appendix or at www.siemens.com/automation/partner

Interactive Catalog on DVD	<i>Catalog</i>		
for Industry Automation, Drive Technologies and Low Voltage Distribution	CA 01		
Drive Systems			
<u>Variable-Speed Drives</u>			
SINAMICS G110, SINAMICS G120	D 11.1		
Standard Inverters			
SINAMICS G110D, SINAMICS G120D			
Distributed Inverters			
SINAMICS G130 Drive Converter Chassis Units	D 11		
SINAMICS G150 Drive Converter Cabinet Units			
SINAMICS GM150, SINAMICS SM150	D 12		
Medium-Voltage Converters			
SINAMICS S120 Chassis Format Units and Cabinet Modules	D 21.3		
SINAMICS S150 Converter Cabinet Units			
SINAMICS DCM Converter Units	D 23.1		
<u>Three-phase Induction Motors</u>	D 84.1		
• H-compact			
• H-compact PLUS			
Asynchronous Motors Standardline	D 86.1		
Synchronous Motors with Permanent-Magnet Technology, HT-direct	D 86.2		
DC Motors	DA 12		
SIMOREG DC MASTER 6RA70 Digital Chassis Converters	DA 21.1		
SIMOREG K 6RA22 Analog Chassis Converters	DA 21.2		
<i>PDF: SIMOREG DC MASTER 6RM70 Digital Converter Cabinet Units</i>	DA 22		
SIMOVERT PM Modular Converter Systems	DA 45		
SIEMOSYN Motors	DA 48		
MICROMASTER 420/430/440 Inverters	DA 51.2		
MICROMASTER 411/COMBIMASTER 411	DA 51.3		
SIMOVERT MASTERDRIVES Vector Control	DA 65.10		
SIMOVERT MASTERDRIVES Motion Control	DA 65.11		
Synchronous and asynchronous servomotors for SIMOVERT MASTERDRIVES	DA 65.3		
SIMODRIVE 611 universal and POSMO	DA 65.4		
SIMOTION, SINAMICS S120 and Motors for Production Machines	PM 21		
SINAMICS S110	PM 22		
The Basic Positioning Drive			
<u>Low-Voltage Three-Phase-Motors</u>			
IEC Squirrel-Cage Motors	D 81.1		
MOTOX Geared Motors	D 87.1		
<u>Automation Systems for Machine Tools SIMODRIVE</u>	NC 60		
• Motors			
• Converter Systems SIMODRIVE 611/POSMO			
<u>Automation Systems for Machine Tools SINAMICS</u>	NC 61		
• Motors			
• Drive System SINAMICS S120			
<u>Mechanical Driving Machines</u>			
FLENDER Standard Couplings	MD 10.1		
FLENDER SIG Standard industrial gear unit	MD 30.1		
Low-Voltage Power Distribution and Electrical Installation Technology			
Protection, Switching, Measuring & Monitoring Devices	LV 10.1		
Switchboards and Distribution Systems	LV 10.2		
GAMMA Building Management Systems	ET G1		
<i>PDF: DELTA Switches and Socket Outlets</i>	ET D1		
SICUBE System Cubicles and Cubicle Air-Conditioning	LV 50		
SIVACON 8PS Busbar Trunking Systems	LV 70		
Motion Control	<i>Catalog</i>		
SINUMERIK & SIMODRIVE	NC 60		
Automation Systems for Machine Tools			
SINUMERIK & SINAMICS	NC 61		
Equipment for Machine Tools			
SINUMERIK 828D BASIC T/BASIC M, SINAMICS S120 Combi and 1FK7/1PH8 motors	NC 82		
SIMOTION, SINAMICS S120 and Motors for Production Machines	PM 21		
SINAMICS S110	PM 22		
The Basic Positioning Drive			
Drive and Control Components for Cranes	CR 1		
Power Supply and System Cabling			
Power supply SITOP	KT 10.1		
System cabling SIMATIC TOP connect	KT 10.2		
Process Instrumentation and Analytics			
Field Instruments for Process Automation	FI 01		
SIREC Recorders and Accessories	MP 20		
SIPART, Controllers and Software	MP 31		
Products for Weighing Technology	WT 10		
<i>PDF: Process Analytical Instruments</i>	PA 01		
<i>PDF: Process Analytics, Components for the System Integration</i>	PA 11		
Safety Integrated			
Safety Technology for Factory Automation	SI 10		
SIMATIC HMI/PC-based Automation			
Human Machine Interface Systems/PC-based Automation	ST 80/ ST PC		
SIMATIC Ident			
Industrial Identification Systems	ID 10		
SIMATIC Industrial Automation Systems			
Products for Totally Integrated Automation and Micro Automation	ST 70		
SIMATIC PCS 7 Process Control System	ST PCS 7		
Add-ons for the SIMATIC PCS 7 Process Control System	ST PCS 7.1		
<i>PDF: Migration solutions with the SIMATIC PCS 7 Process Control System</i>	ST PCS 7.2		
SIMATIC NET			
Industrial Communication	IK PI		
SINVERT Photovoltaics			
Inverters and Components for Photovoltaic Installations	RE 10		
SIRIUS Industrial Controls			
SIRIUS Industrial Controls	IC 10		
SIRIUS Industrial Controls (selected content from catalog IC 10)	IC 90		
System Solutions			
Applications and Products for Industry are part of the interactive catalog CA 01			

Get more information

Control Components and Systems Engineering:
www.siemens.com/sirius

Siemens AG
Industry Sector
Control Components and
Systems Engineering
Postfach 2355
90713 FÜRTH
GERMANY

www.siemens.com/automation

Subject to change without prior notice
PDF only: (E86060-K1010-A191-A1-7600)
MP.R3.CP.0000.00.2.23 KG 1111 214 En
© Siemens AG 2011

The information provided in this catalog contains descriptions or characteristics of performance which in case of actual use do not always apply as described or which may change as a result of further development of the products. An obligation to provide the respective characteristics shall only exist if expressly agreed in the terms of contract. Availability and technical specifications are subject to change without notice.

All product designations may be trademarks or product names of Siemens AG or supplier companies whose use by third parties for their own purposes could violate the rights of the owners.