

SIRIUS · SENTRON · SIVACON

Technical information LV 1 T · 2009



Low-Voltage Controls and Distribution

Answers for industry.

SIEMENS

Related catalogs

Low-Voltage Controls and Distribution

SIRIUS · SENTRON · SIVACON

Order No.:

Catalog LV 1

E86060-K1002-A101-A8-7600

Incl. PDF CD-ROM

Technical Information

E86060-T1002-A101-A8-7600 LV 1 T



Low-Voltage Controls and Distribution

Controls and Components
for Applications according to UL

Order No.:

E86060-K1816-A101-A2-7600

LV 16



SIMATIC NET

Industrial Communication

Order No.:

E86060-K6710-A101-B6-7600

IK PI



SIVACON

System Cubicles and
Cubicle Air-Conditioning

Order No.:

E86060-K1920-A101-A3-7600

LV 50



SIDAC

Reactors and Filters

Order No.:

E86060-K2803-A101-A4-7600

LV 60



SIVACON 8PS

CD-L, BD01, BD2
Busbar Trunking Systems
up to 1250 A

Order No.:

E86060-K1870-A101-A4-7600

LV 70



The Offline Mall

DVD:

E86060-D4001-A510-C7-7600

CA 01



The Online Mall

Internet:

<http://www.siemens.com/automation/mall>

Catalog-PDF

Internet:

<http://www.automation.siemens.com/cd>

Contents

Systems • Controlgear: Contactors and contactor assemblies, solid-state switching devices • Protection equipment • Motor starters, soft starters and load feeders • Monitoring and control devices • Detecting devices • Commanding and signaling devices • Transformers • Power supplies • Planning and configuration with SIRIUS • Power Management System • SIVACON Power, distribution boards, busway and cubicle systems • SENTRON switching and protection devices for power distribution: Air circuit breakers, molded case circuit breakers, switch disconnectors, busbar systems • Software for power distribution • BETA low-voltage circuit protection

SIRIUS 3RV17 and 3RV18 circuit breakers according to UL 489/CSA C22.2 No. 5-02 • SIVACON Components for Feeder Circuit • SENTRON 3WL5 air circuit breakers/non-automatic air circuit breakers according to UL 489/IEC 60947-2 • SENTRON 3VL Molded Case Circuit Breakers according to UL 489/IEC 60947-2 • ALPHA Devices according to UL Standard • BETA Devices according to UL standard

PROFINET/Industrial Ethernet • Industrial Wireless Communication • PROFIBUS • SIMATIC ET 200 distributed I/Os • AS-Interface • Telecontrol • Routers • ECOFAST system

System cubicles • Cubicle modifications • Cubicle expansion components • Accessories • Special cubicles • Cubicle solutions in applications • Cubicle air-conditioning • Special colors

Commutating reactors for converters • Mains reactors for frequency converters • Iron-core output reactors • Ferrite output reactors • Iron-core smoothing reactors • Smoothing air-core reactors • Filter reactors • Application-specific reactors • Radio interference suppression filters • dv/dt filters • Sinewave filters

Busbar trunking systems, overview • CD-L system (25 A to 40 A) • BD01 system (40 A to 160 A) • BD2 system (160 A to 1250 A)

All products of automation, drives and installation technology, including those in the catalogs listed above.

All products of automation, drives and installation technology, including those in the catalogs listed above.

All catalogs for low-voltage controls and distribution can be downloaded as PDF files.

Registered trademarks

All product designations may be registered trademarks or product names of Siemens AG or other supplying companies. Third parties using these trademarks or product names for their own purposes may infringe upon the rights of the trademark owners.

Further information about low-voltage controls is available on the Internet at:

<http://www.siemens.com/lowvoltage>

Technical Assistance

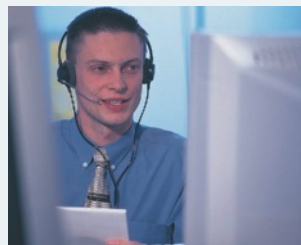

Expert technical assistance for Low-voltage controls and electrical installation.

Tel.: +49 (9 11) 8 95-59 00

Fax: +49 (9 11) 8 95-59 07

E-Mail: technical-assistance@siemens.com

Low-Voltage Controls and Distribution

SIRIUS · SENTRON · SIVACON

Technical Information LV 1 T · 2009



The products and systems listed in this catalog are distributed/ manufactured using a certified quality management system which complies with EN ISO 9001 (for the Certificate Register Nos. see the Appendix). The certificate is recognized in all IQNet countries.

Supersedes:

Technical Information LV 1 T · 2008
Catalog News LV 1 N up to 09/2008

The products in this Technical Information can also be found in the electronic catalog CA 01.

Order No.:

E86060-D4001-A510-C7-7600 (DVD)

Contact your local Siemens sales office for further information

© Siemens AG 2009

1

Introduction

Answers for Industry.
Low-voltage controls and distribution.
The basis for advanced solutions.

2

Systems

AS-Interface
IO-Link
PROFIBUS
SIRIUS Modular System

3

**Controls –
Contactors and Contactor Assemblies**

3RT, 3TB, 3TF Contactors for Switching Motors
3RA13, 3RA14, 3TD, 3TE Contactor Assemblies
3RT, 3RH, 3TB, 3TC, 3TH, 3TK Contactors for Special Applications
3RH, 3TH Contactor Relays · 3RT Coupling Relays
3TX7, 3RS18 Coupling Relays · Coupling Relays with LZS, LZX
Plug-In Relays · 3TG10 Power Relays/Miniature Contactors

4

**Controls –
Solid-State Switching Devices**

For switching resistive loads:
3RF20, 3RF21, 3RF22 Solid-State Relays
3RF23, 3RF24 Solid-State Contactors · 3RF29 Function Modules

For switching motors:
3RF24 Solid-State Contactors and Solid-State Reversing Contactors

5

Protection Equipment

3RV Motor Starter Protectors/Circuit Breakers up to 100 A
3RV Molded Case Motor Starter Protectors up to 800 A
3RU1 Thermal Overload Relays
3RB2 Solid-State Overload Relays

6

Motor Starters, Soft Starters and Load Feeders

3RW Soft Starters
3RA1 Fuseless Load Feeders
3RA6 Compact Feeders
ET 200S Motor Starters
ET 200S Safety Motor Starter Solutions Local/PROFIsafe
ET 200pro Motor Starters · AS-Interface Compact Starters, 400 V
ECOFAST Motor Starters and Soft Starters · 3RE Encapsulated Starters · Motor Starters, 24 V DC

7

Monitoring and Control Devices

SIMOCODE 3UF Motor Management and Control Devices
LOGO! Logic Modules · 3RP, 3RT19 Timing Relays
3UG Monitoring Relays for Electrical and Additional Measurements
3RS10, 3RS11 Temperature Monitoring Relays
3RN1 Thermistor Motor Protection
3TK28 Safety Relays
3RK3 Modular Safety System
3RS17 Interface Converters

8

Detecting Devices

3SE2, 3SE3, 3SE5, 3SF1 Position Switches
3SE2, 3SE5, 3SF1 Hinge Switches
3SE6 Magnetically Operated Switches

9

Commanding and Signaling Devices

3SB2, 3SB3, 3SF5 Pushbutton Units and Indicator Lights
3SB3 Two-Hand Operation Switches
3SE7, 3SF2 Cable-Operated Switches
3SE2, 3SE3 Foot Switches
8WD4 Signaling Columns
8WD5 Integrated Signal Lamps

10

Transformers

Single-Phase Transformers
Three-Phase Transformers

11

Power Supplies

4AV Non-Stabilized Power Supplies

12

Planning and Configuration with SIRIUS

13

SENTRON Power Management System

PAC3200 Multifunction Measuring Instruments

14

**SIVACON Power Distribution Boards,
Busway Systems and Cubicle Systems**

S8, 8PV and 8PT Power Distribution Boards and Motor Control Centers

15

**SENTRON Switching and Protection Devices
for Power Distribution**

3WL Air Circuit Breakers

16

**SENTRON Switching and Protection Devices
for Power Distribution**

3VL, 3VF2 Molded Case Circuit Breakers

17

**SENTRON Switching and Protection Devices
for Power Distribution**

3KA, 3KE, 3LD Switch Disconnectors
3KL, 3KM, 3NJ6 Switch Disconnectors with Fuses
3NP, 3NJ4, 3NJ5 Fuse Switch Disconnectors
SENTRON 8US Busbar Systems

18

Software for Power Distribution

Configuring, Visualizing and Controlling with SIMATIC
Configuring, Visualizing and Controlling with SENTRON

19

BETA Low-Voltage Circuit Protection

20

Appendix

Glossary · Training · Order information · Further documentation · Standards and approvals · Quality management · Siemens contacts · Solution partners · Online services · Customer support · Software licenses · Subject index · Order number index including export markings · Terms and conditions of sale and delivery, export regulations

Explanations

General information

Things you should know about Catalog LV 1 · 2009 and Technical Information LV 1 T · 2009

Catalog LV 1 · 2009 contains selection and order-relevant data under the topic headings "Overview", "Benefits", "Application", "Selection and ordering data", "Accessories", "Options" and "More information".



















The topics "Design", "Function", "Integration", "Configuration", "Programming", "Technical specifications", "Characteristic curves", "Schematics" and "Dimensional drawings" can be found if required in the Technical Information LV 1 T · 2009.

Dimensions

All dimensions in mm.

Symbols

In Catalog LV 1 · 2009 and in the Technical Information LV 1 T · 2009 you will find the symbols listed alongside. These symbols are used in conjunction with an orange background to mark special selection criteria (e.g. connections, types of coordination, etc.).

<i>Terminals</i>	Screw terminals	
	Cage Clamp terminals/spring-loaded terminals	
	Combicon connectors	
	Flat connectors	
	Solder pin connections	
	Ring terminal lug connection	
	Plug-in terminals	
<i>Types of coordination</i>	Type of coordination "1"	
	Type of coordination "2"	
<i>Distinguishing between units</i>	Complete units	
	Modular system	
<i>Switching capacity of 3WL circuit breakers</i>	ECO switching capacity (I_{cu} up to 55/66 kA at 500 V)	
	Standard switching capacity (I_{cu} up to 66/80 kA at 500 V)	
	High switching capacity (I_{cu} up to 100 kA at 500 V)	
	Very high switching capacity (I_{cu} up to 150 kA (3-pole)/130 kA (4-pole) at 500 V)	
	Switching capacity for DC current	
<i>Switching capacity of 3VL circuit breakers</i>	Standard switching capacity (I_{cu} up to 55 kA at 415 V)	
	High switching capacity (I_{cu} up to 70 kA at 415 V)	
	Very high switching capacity (I_{cu} up to 100 kA at 415 V)	

Explanations

ATEX explosion protection

In many industries the production, processing, transport and storage of combustible substances are accompanied by escaping gases, vapor or spray which find their way into the environment. Other processes result in combustible dust. Together with the oxygen in the air, the result can be an explosive atmosphere which will explode if ignited.

Serious injury to persons and damage to property can result particularly in the chemical and petrochemical industry, mineral oil and natural gas production, mining, mills (e.g. grain, solid materials) and many other sectors.

To guarantee the maximum possible safety in these areas, the legislators of most countries have drawn up requirements in the form of laws, regulations and standards. In the course of globalization, great progress has been made with regard to uniform directives for explosion protection.

With Directive 94/9/EC, the European Union laid the foundations for complete harmonization by requiring that all new devices as from 1st July 2003 have to be approved in accordance with this directive.

In this catalog, special attention is drawn to devices which comply with the ATEX Directive. However, it does not replace intensive study of the relevant fundamentals and directives when planning and installing electrical systems.



UL-certified devices

UL standards are applied in North America and a number of other countries. This is important in particular for European exports of electrical switchgear and machine-integrated equipment, above all to the USA. Acceptance and delivery are possible only if the relevant UL standards are satisfied.

UL 508A "Standard for Industrial Control Panels" describes the design of control cabinets and implementation of integral components with reference to other pertinent UL standards where applicable. As such, this standard represents the basis for all electrical systems used in North America.

Our consideration of both IEC directives as well as UL standards as early as in our products' development phase results in a broad portfolio of UL-certified products for low-voltage switching and protection technology.

Whether SENTRON circuit breakers, SIRIUS switching devices – including motor-protective circuit breakers, starters, contactors and overload relays –, SENTRON switch disconnectors, SIRIUS detecting and command devices, busbar systems, terminals, miniature circuit breakers, fuses or SIRIUS transformers and filters – our portfolio of low-voltage controls and distribution

products ensures your being on the safe side in terms of UL and facilitates the easy and fast assembly of control cabinets according to UL.

Our UL-certified portfolio can be found partly in this catalog and in greater concentration in Catalog LV 16, "Controls and Components for Applications according to UL".



Notes



Introduction



1/2

Answers for industry.

1/4

Low-Voltage Controls and Distribution.
The basis for progressive solutions.

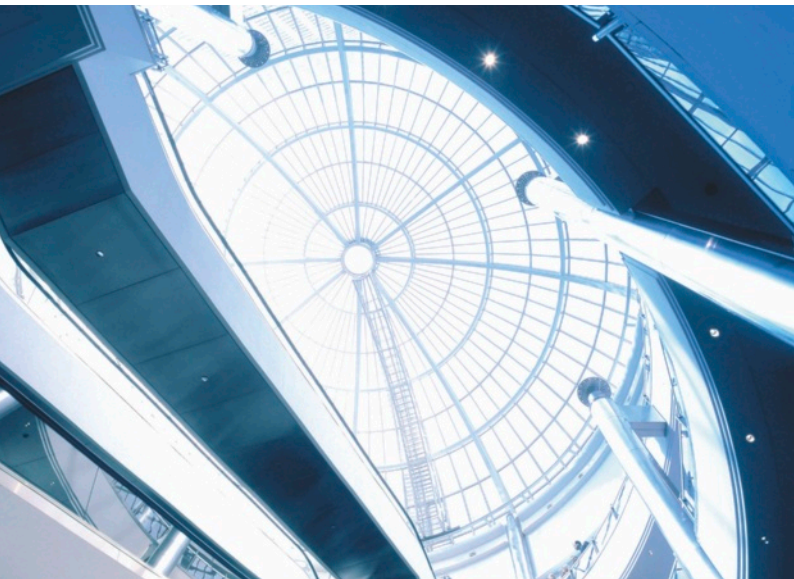
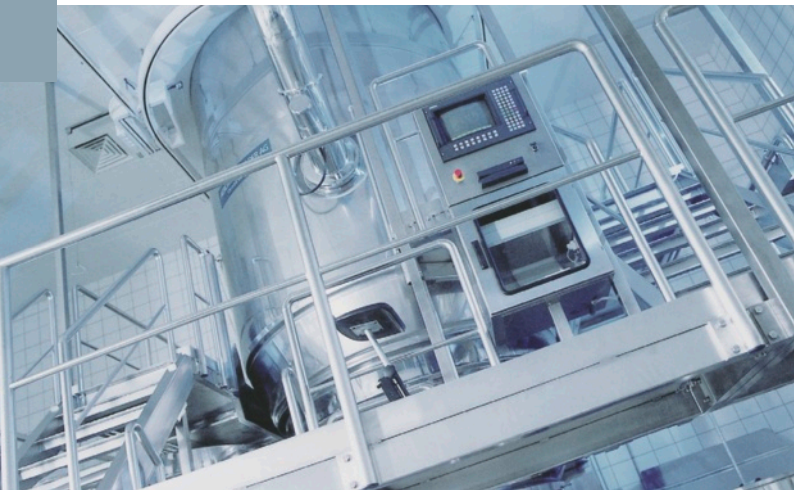

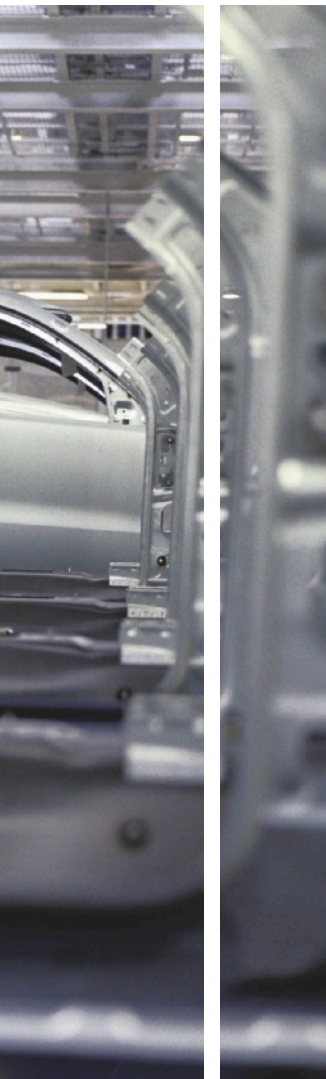

Answers for industry.

Siemens Industry answers the challenges in the manufacturing and the process industry as well as in the building automation business. Our drive and automation solutions based on Totally Integrated Automation (TIA) and Totally Integrated Power (TIP) are employed in all kinds of industry. In the manufacturing and the process industry. In industrial as well as in functional buildings.

Siemens offers automation, drive, and low-voltage switching technology as well as industrial software from standard products up to entire industry solutions. The industry software enables our industry customers to optimize the entire value chain – from product design and development through manufacture and sales up to after-sales service. Our electrical and mechanical components offer integrated technologies for the entire drive train – from couplings to gear units, from motors to control and drive solutions for all engineering industries. Our technology platform TIP offers robust solutions for power distribution.

The high quality of our products sets industry-wide benchmarks. High environmental aims are part of our eco-management, and we implement these aims consistently. Right from product design, possible effects on the environment are examined. Hence many of our products and systems are RoHS compliant (Restriction of Hazardous Substances). As a matter of course, our production sites are certified according to DIN EN ISO 14001, but to us, environmental protection also means most efficient utilization of valuable resources. The best example are our energy-efficient drives with energy savings up to 60 %.

Check out the opportunities our automation and drive solutions provide. And discover how you can sustainably enhance your competitive edge with us.

Low-Voltage Controls and Distribution.

The basis for progressive solutions.

Extremely high demands are made on modern low-voltage controls and distribution:

users want cost-effective solutions that are easy to integrate in control cabinets, distribution boards and distributed systems and can communicate perfectly with each other.

Siemens has the answer: SIRIUS industrial controls and low-voltage power distribution with Power Management, SIVACON and SENTRON.

SIRIUS industrial controls

The SIRIUS range has everything you need for switching, protecting and starting loads. Products for monitoring, control, detection, commanding, signaling and power supply round off the spectrum of industrial controls.

Combined with Totally Integrated Automation, Safety Integrated and ECOFAST, our product portfolio can be bundled to create optimized systems. All in all, Siemens provides innovative controls with modern features, such as integrated communication and safety technology that work to your advantage: The basis for ground-breaking integrated solutions.

Low-voltage power distribution with Power Management, SIVACON and SENTRON

Non-residential buildings and industrial plants have one thing in common: without electricity, everything comes to a halt. The availability, safety and cost effectiveness of the power distribution system is of utmost importance – from the medium voltage supply point through to the socket outlet. And only integrated solutions can ensure maximum efficiency for planning, configuration and operation.

The concept is called Totally Integrated Power from Siemens. Total integration in planning and configuration creates synergies and saves costs. Perfectly matched products and systems provide efficient engineering and reliable operation.





Notes

Systems



2/2 Introduction

AS-Interface

Introduction

- 2/9 Configuration examples
- 2/10 Communication overview

ASIsafe

- 2/11 Introduction
- 2/13 AS-Interface safety monitors
- 2/16 AS-Interface safety modules

Masters

- 2/22 CP 142-2
- 2/23 CP 243-2
- 2/24 CP 343-2
- 2/25 CP 343-2P

Routers

- 2/26 DP/AS-i F-Link
- 2/29 IE/AS-i LINK PN IO
- 2/31 DP/AS-i LINK Advanced
- 2/33 DP/AS-Interface Link 20E

Slaves

- I/O modules for operation in the field
- 2/34 - Introduction
- 2/36 - Digital I/O modules, IP67 - K60
- 2/45 - Digital I/O modules, IP68/ IP69K - K60R
- 2/48 - Digital I/O modules, IP67 - K45
- 2/53 - Digital I/O modules, IP67 - K20
- 2/61 - Analog I/O modules, IP67 - K60
- I/O modules for operation in the control cabinet, IP20
- 2/64 - Introduction
- 2/66 - SlimLine
- 2/77 - F90 modules
- 2/82 - Flat modules
- Special integrated solutions
- 2/83 - AS-Interface communications modules
- Modules with special functions
- 2/87 - Counter modules
- 2/88 - Ground-fault detection modules
- 2/90 - Overvoltage protection modules
- 2/92 AS-Interface connections for LOGO!

Power Supply Units

- 2/93 AS-Interface power supplies, IP20

Transmission Media

- 2/96 AS-Interface shaped cables

System Components and Accessories

- 2/98 Repeaters/extenders
- 2/99 Extension plugs
- 2/102 Addressing units
- 2/103 AS-Interface analyzers
- 2/104 Miscellaneous accessories

IO-Link

- 2/106 System overview
- 2/107 I/O modules
- 2/108 - IO-Link K20 modules

PROFIBUS

System Overview

- 2/110 Process or field communication
- 2/113 Communication overview
- 2/115 Configuration examples
- 2/117 Technical specifications

SIRIUS Modular System

- 2/118 System overview

Introduction

Overview

		Order No.	Page
AS-Interface/ASIsafe			
	<p>ASIsafe enables the integration of safety-oriented components in an AS-Interface network, for example:</p> <ul style="list-style-type: none"> • EMERGENCY-STOP pushbuttons • Protective door switches • Safety light arrays <p>The simple wiring of AS-Interface, which is a major advantage, is maintained.</p>		
	<p>Safety monitor</p> <p>AS-Interface safety monitors</p> <ul style="list-style-type: none"> • Key element of ASIsafe • Monitors safe participants and links safe inputs • Ensures safe disconnection • Modular construction according to individual requirements • Available with one or two release circuits with 2-channel configuration • All versions also with removable screw terminals or spring-type terminals • All safety monitors in revised Version 3 with additional options • Filtering out of brief single-channel interruptions in the sensor circuit with the expanded safety monitor Version 3 • Expanded safety monitor with integrated safe slave for controlling a distributed safe AS-i output or for safe coupling a safe signal from one AS-i network to another AS-i network • New configuration software asimon V3 with graphic function diagram presentation <p>Your advantage: Easy to configure safety functions up to Category 4, PL e, SIL 3.</p>	3RK1	2/13
	<p>K45F</p> <p>AS-Interface safety modules</p> <ul style="list-style-type: none"> • Complete portfolio of ASIsafe modules <ul style="list-style-type: none"> - For connection of safety switches with contacts (position switches etc.) as well as solid-state safety sensors (BWS) • Degree of protection IP65/IP67 or IP20 • Very compact dimensions, from 20 mm width • Two or four inputs in Category 2 or one or two inputs in Category 4 / SIL 3 • Four safe inputs or two additional standard outputs available on the module <p>Your advantage: Easy integration of safe signals, be it in the control cabinet or in the field.</p>	3RK1	2/16
	<p>S22.5F (SlimLine)</p> <p>Position switches</p> <ul style="list-style-type: none"> • Plastic with degree of protection IP65 and metal with degree of protection IP66/IP67 • ASIsafe Electronics integrated in the enclosure, with low power consumption < 60 mA • Available with separate actuator and tumbler <p>Your advantage: Conventional wiring of safety safety functions required no longer required.</p>	3SF1	Ch. 8
	<p>Position switch</p> <p>Cable-operated switches</p> <ul style="list-style-type: none"> • Degree of protection IP65 • Direct connection of cable-operated switches for detection of signals • Metal enclosures 	3SF2	Ch. 9
	<p>Light curtain and array</p> <p>Light curtains/arrays and laser scanners</p> <ul style="list-style-type: none"> • Degree of protection IP65 • Connection to AS-Interface either direct or through safe solid-state input module • Up to Category 3 (laser scanners) or Category 4 (light arrays/curtains) <p>Your advantage: Direct connection of active and optical protection for persons to ASIsafe.</p>	3SF7 3RG7 84...	See Catalog FS 10 "Sensor Technology"
	<p>EMERGENCY-STOP for mounting on front plate</p> <p>EMERGENCY-STOP pushbuttons</p> <ul style="list-style-type: none"> • Degree of protection IP65/IP67 • EMERGENCY-STOP directly on AS-Interface using integrated modules • Metal or plastic version <p>Your advantage: Easy direct connection of service-proven control elements to ASIsafe.</p>	3SF5	Ch. 9

Masters	Order No.	Page
<p>The AS-Interface master connects SIMATIC control systems to AS-Interface. It automatically organizes the data traffic on the AS-Interface cable and sees not only to querying the signals but also to performing the parameter setting, monitoring and diagnostics functions.</p> <p>Masters for SIMATIC</p> <ul style="list-style-type: none"> • Connection of up to 62 AS-Interface slaves • Integrated analog value transmission • Simple configuration by adopting the actual configuration as the desired configuration at the press of a button • Easy operation in the input/output address range • Monitoring of the supply voltage on the AS-Interface shaped cable <p>Your advantage: Easy connection to SIMATIC S7-300, ET200 M, SIMATIC S7-200 or SIMATIC ET 200X.</p>  <p>CP 343-2, CP 343-2P for SIMATIC S7-300</p>  <p>CP 243-2 for SIMATIC S7-200</p>	6GK7	2/22
<p>As an alternative to the CPs, which are plugged directly in the controller it is also possible to use a link as AS-Interface master – at any position beneath the PROFIBUS DP or PROFINET IO.</p> <p>Routers</p> <ul style="list-style-type: none"> • Degree of protection IP20 • PROFIBUS slave or PROFINET IO device and AS-Interface master (single or double master in case of DP/AS-i LINK Advanced and IE/AS-i LINK PN IO) • Connection of up to 62 AS-Interface slaves • Integrated ground-fault monitoring (in case of DP/AS-i LINK Advanced and IE/AS-i LINK PN IO) • User-friendly local diagnostics and local start-up by means of a full graphic display and control keys or through a web interface with a standard browser (in case of DP/AS-i LINK Advanced and IE/AS-i LINK PN IO) • Integrated analog value transmission • Configuring and uploading of AS-Interface configuration in STEP 7 possible • User-friendly selection of AS-Interface slaves • Safety-orientated transition from ASIsafe to PROFIsafe also available as DP/AS-i F-Link <p>Your advantage: Optimum transition to PROFIBUS or PROFINET, integrated in STEP 7.</p>  <p>DP/AS-i F-Link</p>  <p>IE/AS-i LINK PN IO</p>  <p>DP/AS-i LINK Advanced</p>  <p>DP/AS-Interface Link 20E</p>	6GK1	2/22

Introduction

AS-Interface/Slaves

Slaves contain the AS-Interface electronics and connection options for sensors and actuators in the field and in the control cabinet. A total of up to 62 slaves can be connected to one bus. The slaves then exchange their data in cyclic mode with a control module (master).

Field modules/Digital I/O modules IP67 - K60, K45 and K20

- Degree of protection IP65/IP67
- Modules available with up to degree of protection IP68/69K
- ATEX-certified modules available for Ex Zone 22
- Connection sockets in M8/M12
- Up to eight inputs and four outputs
- A/B technology available
- Contacting protected against polarity reversal
- Standard rail mounting and wall mounting possible
- Mounting of the module on the base plate using just one screw
- Diagnostics LEDs

Your advantage: Reduction of mounting and start-up times by up to 40 %.

Order No.

Page

3RK1, 3RK2

2/36, 2/48, 2/53



K20 digital module



K45 digital module



K60 digital module

Field modules/Analog I/O modules IP67 - K60

- Degree of protection IP65/IP67
- Detects or transmits analog signals locally
- 2/4-channel
- Input modules for up to four sensors with current signal, sensors with voltage signal or sensors with thermal resistor
- Output modules for current or voltage

Your advantage: Easy integration of analog values.

3RK1

2/61



K60 analog module

Cabinet modules

- Degree of protection IP20
- No M12 plugs required for connection
- Up to 16 inputs
- Narrow design of the SlimLine modules with width from 22.5 mm
- Removable, finger-safe terminal blocks that cannot be mixed up (SlimLine)
- Flat design of the flat modules for small control cabinets and confined conditions
- Connection with screw-type or spring-type terminals
- Standard rail mounting and wall mounting possible
- Diagnostics LEDs

Your advantage: Modules enable use in cabinets and small local control cabinets.

3RG9, 3RK1

2/66









SlimLine



F90 module

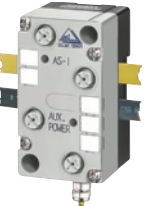

Flat module

		Order No.	Page
	Modules with special functions/Counter modules <ul style="list-style-type: none"> Degree of protection IP20 For evaluation of pulses Connection with screw-type or spring-type terminals <p>Your advantage: Evaluation of pulses which exceed even the clock frequency of AS-Interface.</p>	3RK1	2/87
Counter module			
	Modules with special functions/Ground-fault detection modules <ul style="list-style-type: none"> Degree of protection IP20 Display using LEDs Two signaling outputs <p>Your advantage: Automatic diagnostics of ground faults on AS-Interface.</p>	3RK1	2/88
Ground-fault detection module			
	Modules with special functions/Overvoltage protection modules <ul style="list-style-type: none"> Degree of protection IP67 Discharge through ground cable with oil-proof outer sheath Protection at transition of lightning protection zones <p>Your advantage: The AS-Interface overvoltage protection module protects downstream AS-Interface devices or individual sections in AS-Interface networks from conducted overvoltages.</p>	3RK1	2/90
Overvoltage protection module			
	Compact feeders <ul style="list-style-type: none"> 3RA61 direct-on-line starters, 3RA62 reversing starters Degree of protection IP20 Up to 15 kW/400 V Wide setting range Weld-free Removable terminals Optional AS-i add-on module <p>Your advantage: Less space and wiring work needed in the control cabinet, no welding, connection to AS-Interface.</p>	3RA6	Ch. 6
3RA61 compact feeder			
	Motor starters/Compact starters (400 V AC) <ul style="list-style-type: none"> Degree of protection IP65/IP67 Up to 5.5 kW at 400/500 V AC Electromechanical or solid-state design Optional with brake contact <p>Your advantage: No local control cabinets required thanks to completely factory-wired load feeder with IP65 protection.</p>	3RK1	Ch. 6
Compact starter			
	Motor starters/ECOFAST motor starters and soft starters <ul style="list-style-type: none"> Degree of protection IP65/IP67 Standardized interfaces according to ECOFAST Specification (DESINA-conform) Mechanical or solid-state soft switching function <p>Your advantage: Less space required in the control cabinet, the starters can be installed near the motor or be plugged on the motor.</p>	3RK1	Ch. 6
ECOFAST motor starter			
	Motor starters/Motor starters (24 V DC) <ul style="list-style-type: none"> Degree of protection IP65/IP67 Direct-on-line starters, double starters or reversing starters Up to 70 W Quick stop function <p>Your advantage: Simple motor starter in service-proven module construction for 24 V DC motors.</p>	3RK1	Ch. 6
Motor starter			

Introduction



Pushbutton unit

Pushbutton units and indicator lights

- Modular construction according to individual requirements
- Metal and plastic version
- Available with standard or A/B slaves and ASIsafe slave
- With LEDs

Your advantage: Complete 3SF58 operating system with simple AS-Interface connection for your plant.

Order No.**3SF58****Page**

Ch. 9



Signaling column

Signaling columns

- Many optical and acoustic elements can be combined
- Also as A/B slaves according to AS-Interface Specification 2.1
- Up to three signaling elements can be connected using an adapter element
- With LEDs or incandescent lamps

Your advantage: Signaling columns for monitoring production sequences and for visual or acoustic warnings in emergency situations, with easy AS-Interface connection.

8WD4

Ch. 9



Connection for LOGO!

AS-Interface connections for LOGO!

- AS-Interface slave for the connection of LOGO!
- Distributed controller functionality
- Four inputs/four outputs (virtual)

Your advantage: Intelligence can be used locally.

3RK1

2/92

AS-Interface/Power supply units

AS-Interface power supply units generate a controlled direct voltage of 30 V DC with high stability and low residual ripple, working according to the principle of a primary switchgear. They are an integral component of the AS-Interface network and enable the simultaneous transmission of data and energy on one cable.



IP20, 3 A

Power supply units

Power supply units with safety class IP20:

- With wide performance spectrum from 2.6 to 8 A
- UL/CSA approval means the power supplies can be used worldwide
The 2.6 A version is approved according to NEC Class 2
- Less space required thanks to compact dimensions
- Easy and quick installation
- Certified for global use
- Integrated ground-fault and overload detection save the need for additional components and makes applications reliable
- Diagnostics memory, remote indication and remote reset allow fast detection of faults in the system
- Removable terminal blocks reduce downtimes
- The ultra-wide input range enables single- and two-phase applications (8 A version)

Your advantage: Optimum performance for each application.

3RX9

2/93



IP20, 8 A

AS-Interface/Transmission media

AS-Interface shaped cable for connection of network stations.



Shaped cable

AS-Interface shaped cables

- No polarity reversal thanks to trapezoidal shape
- Cables made of optimized material for different operating conditions
- Special version according to UL Class 2 available

Your advantage: Fast replacement and connection to AS-Interface by piercing method.

3RX9

2/96

AS-Interface/System components and accessories

Order No.

Page

Accessories comprise tools for mounting, installation and operating as well as individual components.

Repeaters/extenders and extension plugs

- Repeaters for extending the AS-Interface cable by 100 m per repeater
- Extenders for increasing the distance (max. 100 m) between a master and the AS-Interface segment
- Maximum two repeaters or one extender and one repeater in series
- Parallel switching of several repeaters possible (star configuration option)
- Maximum size increases (when combined) to more than 600 m
- Easy mounting
- IP67 module enclosure

Your advantage: Lower infrastructure costs, more possibilities of use and greater freedom for plant planning.



Repeater
(6GK1 210-0SA01)



Extension plug



Addressing unit



Analyzer

Addressing units

- Addressing all stations of the AS-Interface network (standard and A/B slaves)
- Reading out the slave profile (I/O.ID.ID2 and ID1 code)
- Setting the ID1 code and temporary setting of the slave parameters (e. g. for testing of analog slaves)
- Measurement of AS-Interface voltage
- Enables direct setting of outputs and reading in of a slave's inputs
- Storage of complete system configurations

Your advantage: Easiest way to address and parameterize the slaves.

AS-Interface analyzers

- Diagnostics units for completely checking the quality and function of an AS-Interface installation
- Transmission of collected data through an RS 232 interface to a PC, evaluation by software
- Easy and user-friendly operation
- Automatically generated test logs
- Advanced trigger functions enable exact analysis
- Process data can be monitored online
- In addition to digital I/O data it is also possible to view analog values and safety slaves in data mode

Your advantage: Preventative testing of an AS-Interface network is possible, recorded logs facilitate remote diagnostics.

Miscellaneous accessories

Individual components such as sealing caps, cable adapters, distributors etc.



M12 sealing cap



Cable terminating piece

3RK1, 6GK1

Repeaters/
extenders: 2/98
Extension
plugs: 2/99

3RK1

2/102

3RK1

2/103

3RG7, 3RG9, 3RK1,
3RX9, 6ES7 2/104

Introduction

IO-Link



The newly developed IO-Link system offers the following advantages for connecting complex (intelligent) sensors/actuators:

- Only 2 units required: IO-Link master and IO-Link device
- Dynamic changing of sensor/actuator parameters directly by the PLC
- Devices can be exchanged during operation without need for re-parameterization
- Consistent diagnostic information as far as the sensor/actuator level
- Uniform and greatly reduced wiring of different sensors/actuators
- Reduction of parameterization tools
- Transparent representation of all parameter and diagnostics data
- Signals and indicators for preventive maintenance

Your advantage: Fast commissioning and flexible maintenance thanks to central data storage, less wiring work because no passive distributors are needed.

Order No.

Page

6ES7 138
3RK5

2/106

PROFIBUS

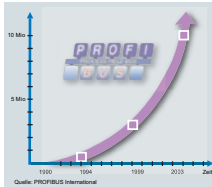

- PROFIBUS is an efficient, open and robust bus system which guarantees smooth communication
- The system is fully standardized, thus enabling standardized components from different manufacturers to be connected without problem
- Configuring, commissioning and troubleshooting can be performed from any position; this means that the freely selectable communication relationships are very flexible, easy to implement and simple to change
- Fast local assembly and commissioning using the FastConnect cabling system
- Constant monitoring of the network components by means of a simple and effective signaling concept
- High protection for your investment because existing systems can be expanded without repercussions
- High availability thanks to ring redundancy with OLM
- Optimum connection of the actuator-sensor level by router to AS-Interface

2/110

SIRIUS modular system



- Load feeders up to 250 kW/400 V are easy to implement from standard devices
- Modular design: Everything fits together and can be combined
- Economical and flexible thanks to seven compact sizes
- Optimum variance with uniform accessories
- Space-saving design with small device width and butt-mounting type of construction up to 60 °C
- Fast commissioning, short setting-up times and simple wiring
- Connection to AS-Interface and PROFIBUS DP possible
- Extremely long life, low maintenance and reliable
- Global approvals and certifications such as IEC, UL, CSA, CCC, shipbuilding
- Permanently secure mounting, screw- or snap-connection
- Spring-type terminals: Quick and secure connection, vibration-proof and maintenance-free
- Short delivery times thanks to world-wide logistics network
- Environment-friendly production and materials, recycling capability, low power loss
- Clear-cut, ergonomic design (winner of the iF Product Design Award)

2/118

Note:



Screw terminals



Spring-type terminals



Combicon connection

These connections are indicated in the Technical specifications by orange backgrounds.

Design

Process or field communication

AS-Interface is used where individual actuators and sensors are spaced apart over a machine (e. g. a bottle filling line, production line, etc.).

It replaces complicated cable harnesses and connects binary and analog actuators and sensors such as proximity switches, valves and indicator lights to a controller, e. g. a SIMATIC or PC.

In practice this means: Installation is straightforward because data and energy are conveyed together over one cable. No special know-how for installation and commissioning is required. And thanks to the simple laying of the cable, its clear-cut structure and special version there is not only far less risk of errors but also less effort during maintenance and servicing.

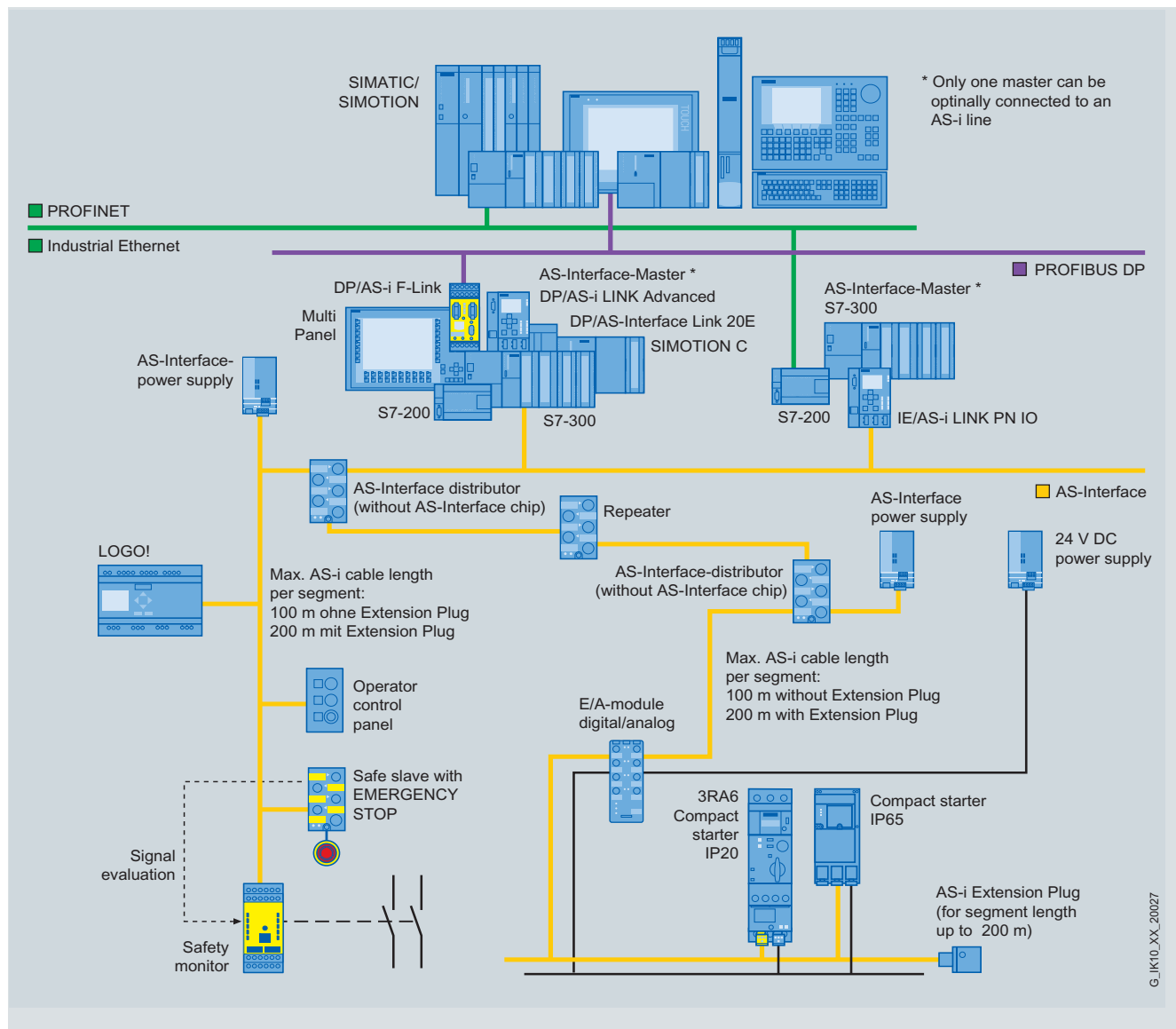

Example of a system configuration

AS-Interface

Introduction

Communication overview

Overview

System components

Numerous system components are offered for implementing the communication. The key elements of a system installation are:

- Master interface modules for central control units such as SIMATIC S5 and SIMATIC S7, distributed peripherals
- AS-Interface shaped cables
- Optional network components such as repeaters/extenders
- Power supplies for slaves, modules for connection of standard sensors/actuators
- Actuators and sensors with integrated slave ASIC
- Safety modules for transmitting safe data through AS-Interface
- Addressing units for setting the slave address

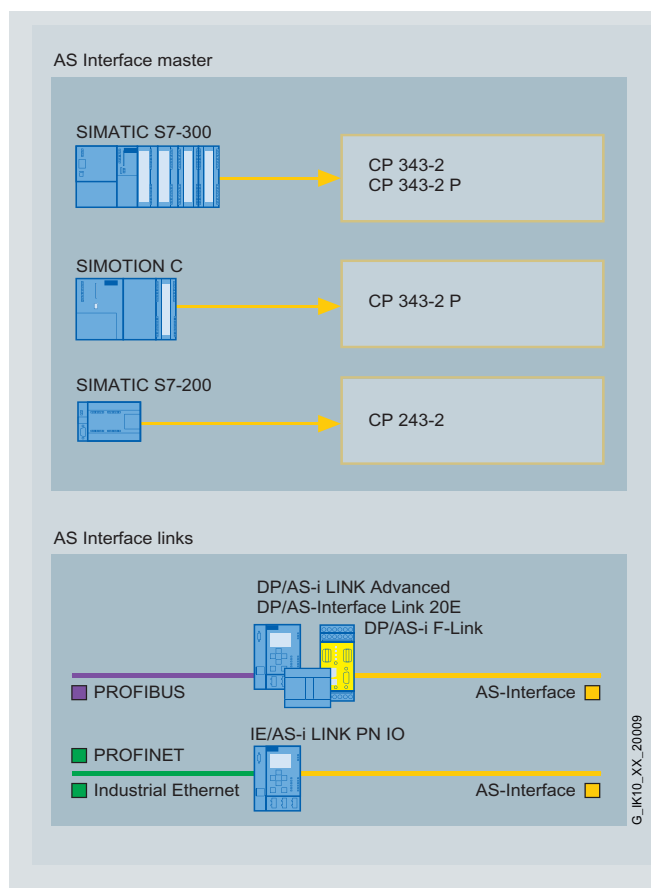

AS-Interface masters and AS-Interface links (see Routers)

Technical specifications

Standard	EN 50295/IEC 61158
Topology	Line, star or tree structure (same as electrical wiring)
Transmission medium	Unshielded two-conductor cable (2 x 1.5 mm ²) for data and auxiliary power
Connection methods	Contacting of the AS-Interface cable by insulation piercing method
Maximum cable length	100 m without repeater/extender; 200 m with extension plug; 300 m with repeater or extender; 600 m with repeater/extender and extension plug (parallel connection of repeaters)
Maximum cycle time	5 ms with full expansion, 10 ms when using A/B technology, profile-specific for Spec 3.0 slaves;
Number of stations per AS-Interface line	31 slaves acc. to AS-Interface Spec. V2.0; 62 slaves (A/B technology) acc. to AS-Interface Spec. V2.1 and V3.0, integrated analog value transmission
Number of binary sensors and actuators	Max. 124 I/124 O acc. to Spec. V2.0; Max. 248 I/186 O acc. to Spec. V2.1; Max. 496 I/496 O acc. to Spec. 3.0
Access control	Cyclic polling master slave method, cyclic data transfer by host (PLC, PC)
Error safeguard	Identification and repetition of faulty message frames

More information

For the SIMATIC NET products referred to above (order numbers 6GK..., 6XV1...) please also note the conditions of application, which can be consulted on the Internet site quoted below.

You can find more information on the Internet at:

<http://www.siemens.com/simatic-net/ik-info>

AS-Interface system manual

More information about AS-Interface is available in the AS-Interface system manual.

The German-language AS-Interface System Manual can be downloaded free from the Internet at:

<http://support.automation.siemens.com/WW/view/de/26250840>

The English-language AS-Interface System Manual can be downloaded free from the Internet at:

<http://support.automation.siemens.com/WW/view/en/26250840>

A print version of the AS-Interface System Manual is also available in both German and English; see LV 1 Chapter "Systems" --> "AS-Interface" --> "System components and accessories" --> "Miscellaneous accessories".

Overview

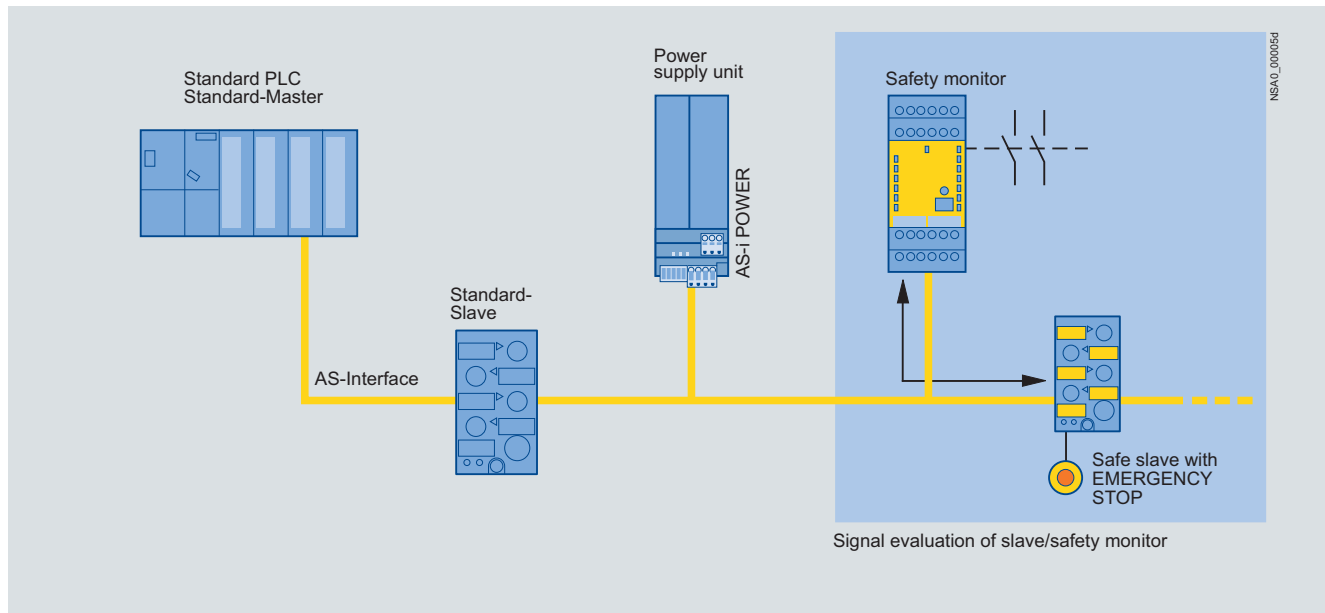

Secure communication and standard communication on AS-Interface

Safety is included

The ASIsafe concept supports the direct integration of safety-related components, such as emergency-stop switches, protective door switches or safety light arrays, in the AS-Interface network. These are fully compatible with the familiar AS-Interface components (masters, slaves, power supplies, repeaters, etc.) according to IEC 62026/EN 50295 and are operated in conjunction with them on the yellow AS-Interface cable.

The signals of the safety sensors are evaluated by a safety monitor which not only monitors the switching signals of the safety sensors but also continuously checks that the data transmission works correctly. The safety monitor has one or two enabling circuits which are configured with two channels and are used to switch the machine or plant to the safe state. Sensors and monitors can be connected to any points of the AS-Interface network. Also, several monitors can be used on one network.

A failsafe controller or a special master is not required. The master regards safety slaves like all other slaves and receives the safety data solely for information purposes. Hence it is also possible to expand all existing AS-Interface networks.

ASIsafe ensures a maximum response time of 40 ms. This is the time between the signal being applied to the input of the safe slave and the output on the safety monitor being switched off.

Tested safety

The system was tested and approved by TÜV (Germany), NRTL (USA) and INRS (France). The transmission procedure for safety-oriented signals is configured for implementing applications up to Category 4 according to EN 954-1, up to PL e according to EN ISO 13849-1 and up to SIL 3 according to IEC 61508.

Software

With the asimon configuration software you can compile safety-oriented applications and transfer them into the monitor. The software also enables online diagnostics.

AS-Interface

ASIsafe

Introduction

Design

The design of the safety systems is identical to the wiring of AS-Interface as it is known today.

The family of safe AS-Interface products comprises the safety monitor which monitors the safe stations. The range of safe stations comprises the safety modules and the safety-related sensors with integrated interface.

The components of ASIsafe

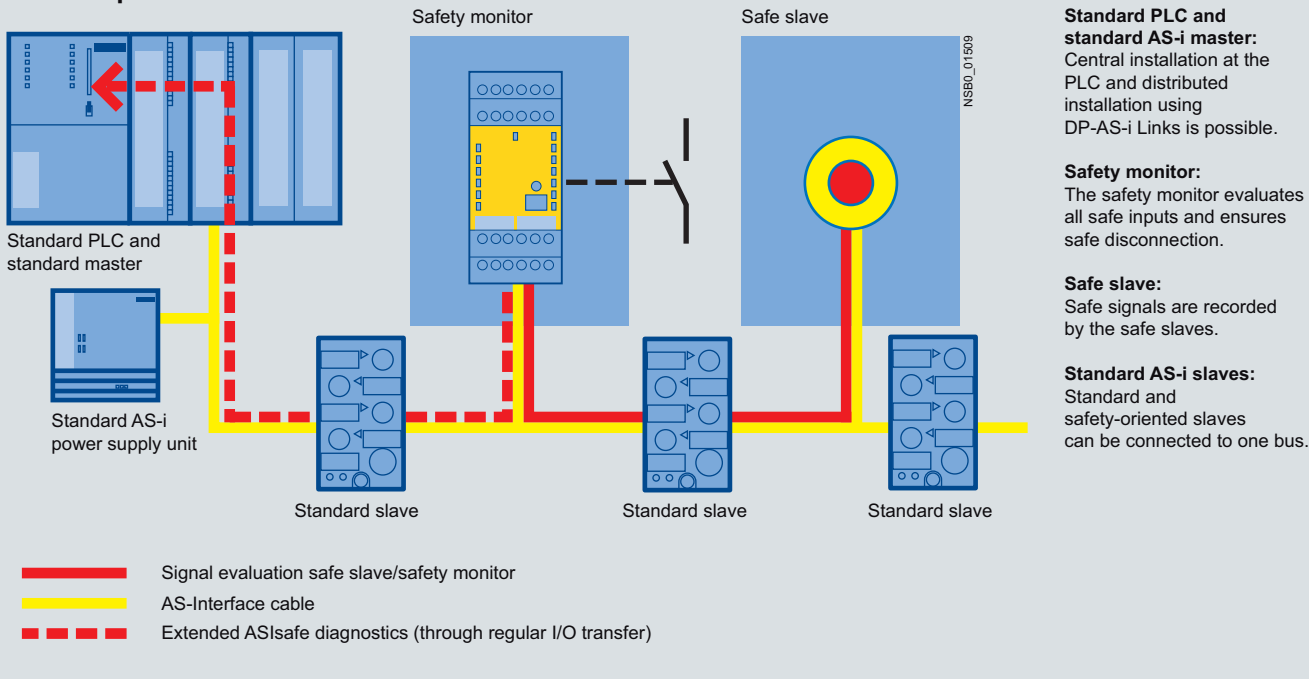

Function

Like the standard stations, the safe stations send their information to the master after master calls. The safety monitor monitors this transmission from the safe stations to the master and switches into the safe state.

The safety monitor is configured with the software "asimon". The configuration comprises the input signals of the safe stations and the internal functions of the safety monitor. The safety monitor provides OR logic, AND logic, timer functions, buffer storage, etc.

Integration

The existing infrastructure such as the master and the power supply unit can be used as before for integrating the safety systems in AS-Interface. For the safety systems the safety monitor is integrated as monitoring element and the safe stations as interface between the safe sensors and the system. The safe sensors can be used as before.

Integration within TIA is performed using function blocks which are offered on the ASIsafe CD-ROM for S7-200 and S7-300. These function blocks enable detailed diagnostics of all parameterized modules. This requires an AS-i address to be issued to the safety monitor by means of the configuration software. Evaluation is performed by means of function blocks in the PLC. With the help of prefabricated WinCC flexible modules this evaluation can then be visualized system-wide on existing HMI devices (OP/TP 270 and higher).

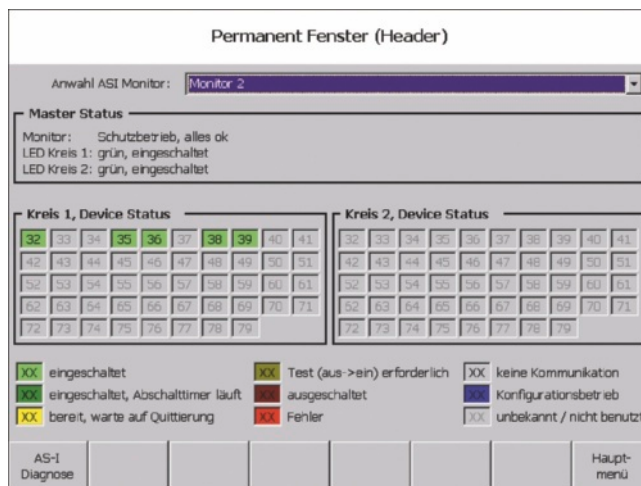

Overview

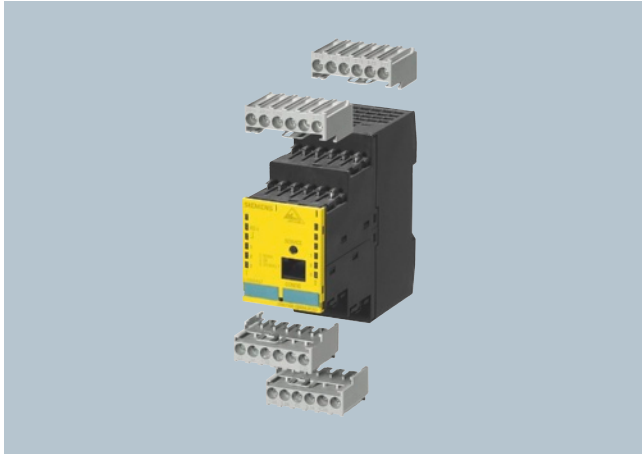

Safety monitor with screw terminals (removable terminals)

The safety monitor is the centerpiece of ASIsafe Solution local. It enables safety-orientated responding to signals from the ASIsafe (input) slaves on the same AS-i network and has 1-2 enabling circuits. A safe application is configured using a PC. Various application-specific operating modes can be selected for this. They include, for example, an EMERGENCY-STOP function, door tumbler and selection of stop Category 0 or Category 1.

To be able to make full use of the AS-Interface diagnostics options, the monitor can also be operated with an AS interface address if required. With the help of the diagnostics module for STEP 7, which is included on the ASIsafe CD, the full diagnostics spectrum can be processed further in the higher-level PLC.

The AS-Interface safety monitor is currently offered in the latest Version 3 (Firmware V3.x) and is available in three expansion levels.

Both basic/expanded expansion levels are available with one or two-channeled configured enabling circuits.

The expanded safety monitor is also available as a version with integrated safe slave which can be used for the control of a safe AS-i output or for safe coupling of a switch signal on another safety monitor or F-Link.

The safety monitor is used in an AS-Interface bus system to monitor protective devices, e. g. protective doors, EMERGENCY-STOP switches, etc.

The safety monitor can be used up to Category 4 acc. to EN 954-1, to PL e acc. to EN ISO 13849-1 and to SIL 3 acc. to IEC 61508.

The safety characteristics for the maximum ON period of 12 months and maximum service life of 20 years are:

- PFD: 7.2×10^{-5}
- PFH: 9.1×10^{-9}

The user must calculate the PFD value of the total loop.

Note:

Depending on the choice of safety components used, the complete safety system may also be classified in a lower safety category.

The safety monitor is mounted on the standard mounting rail. Disassembly from the standard mounting rail is quick and easy and requires no tools. With an additional accessory (push-in lugs), the safety monitor can also be screwed on.

Application

The safety monitor acts as a "bus-based safety relay". It provides a user-friendly introduction to safety-orientated communication over fieldbuses thanks to its simple configuration using the graphic PC software asimon. The standard infrastructure of the AS-i network (AS-i master under standard PLC, AS-i power supply unit) can still be used without restriction.

The monitor comes in three expansion levels:

- Basic safety monitor with starter set of modules and basic functionality
- Expanded safety monitor with expanded features and functionality
- The expanded safety monitor is also available as a version with integrated safe slave which can be used for the control of a distributed safe AS-i output or for safe coupling of a switch signal on another safety monitor or F-Link.

Basic safety monitor versus expanded safety monitor

	Basic	Expanded
Number of monitoring modules	32	48
Number of OR gates (inputs)	2	6
Number of AND gates (inputs)	--	6
Wildcards for monitoring modules	✓	✓
Deactivating of monitoring modules	✓	✓
Fault release	✓	✓
Diagnostics hold	✓	✓
A/B slaves for acknowledgment	✓	✓
Safe time functions	--	✓
"Button" function	--	✓
Debouncing of contacts	--	✓
Filtering out of brief disconnections	--	✓ (as of Version 3)
Control of safe AS-i output/safe coupling	--	✓ (in version with integrated safe slave)

✓ Available

-- Not available

Number of monitoring modules

The number of devices which the safety monitor can process is increased with the expanded safety monitor from 32 to 48. Applications of greater complexity and size can thus be simulated in the safety monitor.

Logic OR operation

At the logic operation level two elements can be linked by OR operations in the basic version and up to six in the expanded version.

Logic AND operation

In addition to the standard AND operation in the main path of an enabling circuit, an AND operation can also be inserted in an OR operation on the expanded safety monitor. More than two elements can be linked in this AND.

AS-Interface

ASIsafe

AS-Interface safety monitors

Features of the basic safety monitor

- Wildcards and deactivating of monitoring modules
Wildcards are available for the configuration. They are integrated in the configuration and diagnostics and can be easily activated if required. User-friendly configuring is thus possible even when system configurations change.
- Fault release:
If a module detects a fault, the AS-Interface safety monitor goes into fault status. A differentiated fault release (reset) is now possible for this scenario. The fault release can be activated by an AS-Interface standard slave, e. g. a pushbutton, and is effective only on module level. The great advantage of this is that the entire safety monitor is no longer reset but only the module which is locked in the fault.
- Diagnostics hold:
Disconnections can be "frozen" until an acknowledgment comes through a standard slave. This function provides valuable help in the event of short-time causes of disconnection.
- Also from Version 3 upwards:
The standard output data bits of safe input slaves can be processed for acknowledgment, fault release and other non-safety-oriented signals.

Additional features of the expanded safety monitor

The following additional features are provided by only the expanded safety monitor:

- Safe time functions:
Timers with the following functions are available:
 - ON-delay
 - OFF-delay and
 - Pulse
- "Button" function:
Additional acknowledgment option for restarting the system using an additional button. The button function can be assigned to any input or output signal of a standard slave through configuration in the asimon software.
- Debouncing of contacts:
For debouncing the contacts it is possible to set a bounce time after which a system restart takes place.
- Also from Version 3 upwards:
Filtering out of brief single-channel interruptions in the sensor circuit. A tolerance time can be set during which the brief opening of a safety-oriented input contact is ignored in order to increase plant availability.

Additional features of the expanded safety monitor with integrated safe slave

This new safety monitor type offers the additional features of the expanded safety monitor plus the following features:

- Filtering out of brief single-channel interruptions in the sensor circuit.
- Actuating a safe distributed actuator (safe output module of e. g. safe valves or motor starters) parallel to the 2nd enabling circuit.
- Alternatively: Use as a "safe coupler" between two ASIsafe networks. A safe input signal on network 1 can thus act on an enabling circuit of network 2. A detour through a hard-wired safe input module on network 2 is not required in this case.

Configuration software asimon V3: new features

- Multi-window system
- Creation of the safety logic in graphic function diagram form, with changeover to former tree presentation possible
- No "preprocessing" of the safety logic
- Management of user-specific modules
- Downward compatibility:
 - Existing asimon V2 projects can be loaded
 - Can also be used on all former versions of the safety monitor with the corresponding scope of functions
- Graphic printout of the safety logic
- Easier system start-up:
 - Teaching the code sequences of safe AS-Interface slaves
 - Manual input of code sequences also possible in addition
 - Selectable number of simulated slaves
- Simpler diagnostics using AS-Interface through assignment of a diagnostics index to the software function block
- Signaling the switching state of the signaling and relay outputs to higher-level PLCs using a simulated AS-Interface slave
- New functions for filtering out brief interruptions and for controlling a safe AS-i output or for safe coupling of two AS-i networks

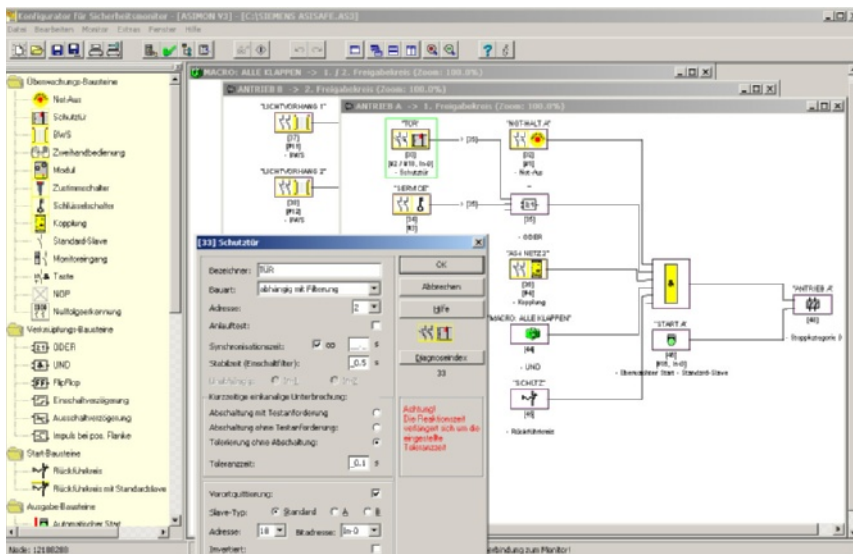

Interface of the configuration software asimon V3

Technical specifications

3RK1 105 safety monitor

Rated operational current

I_{θ} /AC-12 up to 250 V	A	3
I_{θ} /AC-15		
• 115 V	A	3
• 230 V	A	3
I_{θ} /DC-12 up to 24 V	A	3
I_{θ} /DC-13		
• 24 V	A	1
• 115 V	A	0.1
• 230 V	A	0.05

Response time ms ≤ 40

Achievable performance level acc. to EN ISO 13849-1 PL e

Achievable SIL (or SILCL) acc. to EN 62061 SIL 3

Failure probability (PFH_D) acc. to EN 62061 9.1 x 10⁻⁹

For max. ON period of 12 months, service life of 20 years

Ambient temperature °C 0 ... +60

Storage temperature °C -40 ... +85

Dimensional drawings

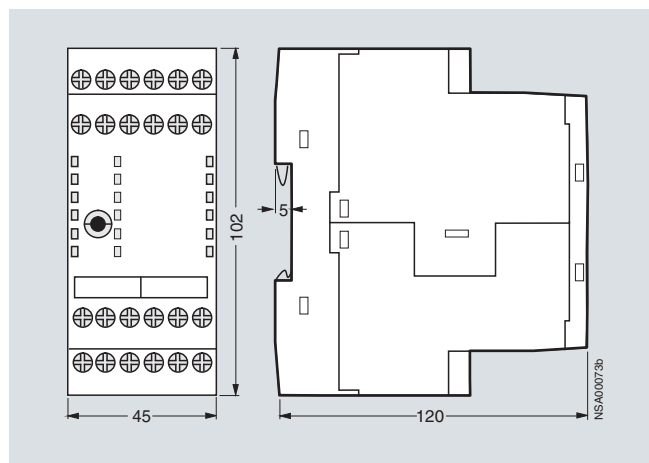

Safety monitor

Schematics

The protective conductor must be connected to the FE connection if the terminal M is not connected to ground in the direct vicinity of the unit.

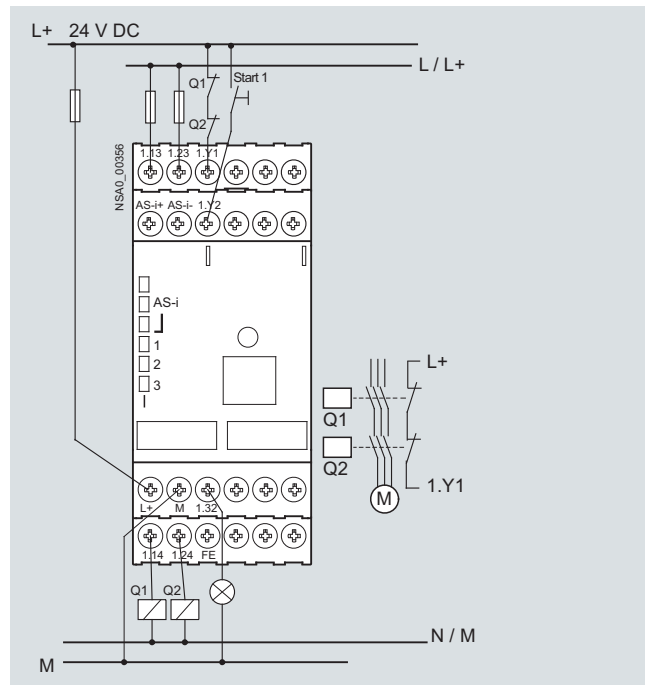

Safety monitor type 1, type 3 – with one enabling circuit

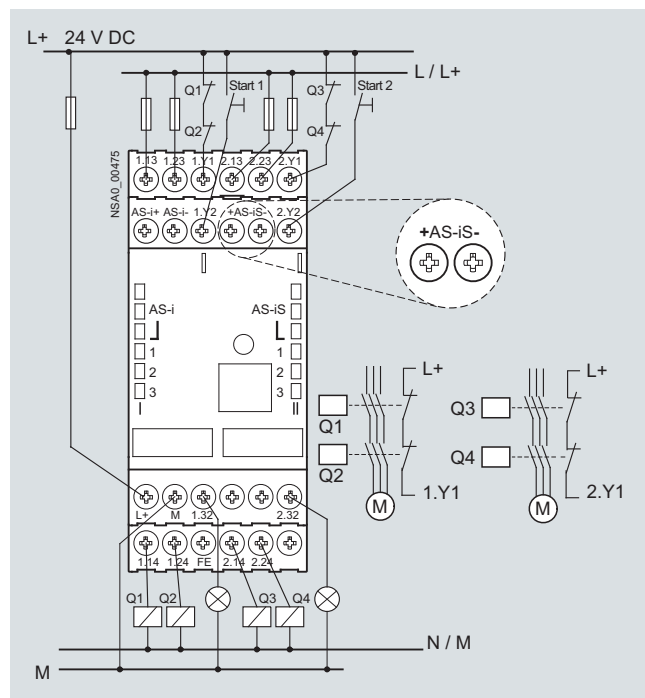

Safety monitor type 2, type 4, type 6 – with two enabling circuits (terminals AS-iS+/AS-iS- only for type 6)

AS-Interface

ASIsafe

AS-Interface safety modules

Overview



Safety modules for AS-Interface (ASIsafe modules) are available for field use in degree of protection IP67 (K20F and K45F compact modules) and for the control cabinet (S22.5F SlimLine modules) in degree of protection IP20.

A very compact module with an optimum price /performance ratio is thus available for very application.

Following modules are available for selection:

K20F compact safety modules for operation in the field

Being only 20 mm wide, the K20F module is particularly well suited for applications where modules need to be arranged in the most confined space. The K20F modules are connected to the AS-Interface with a round cable with M12 cable box instead of with the AS-Interface flat cable. This enables extremely compact installation. The flexibility of the round cable means that it can also be used on moving machine parts without any problems. The K20 modules are also ideal for such applications as their non-encapsulated design makes them particularly light in weight.

K45F compact safety modules for operation in the field

The platform of the K45F modules covers the following variations:

- Connection of ("mechanical") switches/safety sensors with contacts:
 - K45F 2F-DI: two safety-oriented inputs in operation up to Category 2 according to EN 954-1. If Category 4 is required, a two-channel input is available on the module.
 - K45F 2F-DI/2DO: There are also two standard outputs in addition to the safe inputs. Supplied from the yellow AS-i cable
 - K45F 2F-DI/2DO U_{aux} : same as K45F 2F-DI/2DO, but supplied from the black 24 V DC cable
 - K45F 4F-DI: four safety-oriented inputs in operation up to Category 2, two for Category 4. Extremely compact double slave (uses two full AS-i addresses).
- Connection of solid-state switches/safety sensors (non-contact protective devices, BWS):
 - K45F LS (light sensor): safe input module for connection of solid-state safety sensors with testing semiconductor outputs (OSSD). In particular non-contact protective devices (BWS) such as active, optoelectronic light arrays and light curtains for Type 2 and Type 4 according to IEC/EN 61496. Transmitters as well as receivers are supplied with power from the yellow AS-i cable. Matching sensor cables and optionally a separate transmitter supply module are available as accessories.

S22.5F SlimLine safety modules for operation in control cabinets and local control cabinets

The S22.5F SlimLine safety module has two safety inputs. The safe connection of signals to ASIsafe networks in the control cabinet is also possible therefore. For operation up to Category 2, both inputs can be assigned separately; if Category 4 is required, a two-channel input is available on the module.

In addition there are two S22.5F module versions which have two standard outputs in addition to the two safety inputs; power is supplied either from only the yellow AS-Interface cable or as auxiliary voltage from the black 24 V DC cable.

Technical specifications



	K20F compact safety modules		K45F compact safety modules			
	2 inputs, safe	2 inputs, safe	4 inputs, safe	2 inputs, safe	2 inputs, safe	2 inputs, safe, BWS for 1 light curtain
	--	--	--	2 outputs, standard	2 outputs, standard with U_{aux}	2 F-DI (solid-state, LS - light sensor)
	2 F-DI	2 F-DI	4 F-DI	2 F-DI/2 DO	2 F-DI/2 DO with U_{aux}	2 F-DI (solid-state, LS type 2)
	3RK1 205-0BQ30-0AA3	3RK1 205-0BQ00-0AA3	3RK1 205-0CQ00-0AA3	3RK1 405-0BQ20-0AA3	3RK1 405-1BQ20-0AA3	3RK1 205-0BQ21-0AA3 3RK1 205-0BQ24-0AA3 LS type 4
AS-Interface chip	SAP 5			SAP 5		
I/O configuration	0			7		0
ID/ID2 code	B/0	B/F		B/F		B/1
PFD value	Makes no notable contribution to the PFD of the overall system, comprised of the AS-Interface bus and safety monitor					
Operational voltage acc. to AS-Interface specification	V	26.5 ... 31.5		26.5 ... 31.5		
Total current input	mA	≤ 45	≤ 70	≤ 250	≤ 60	≤ 60
Inputs						
• Sensors		Mechanical switching contact		Mechanical switching contact		Testing semiconductor outputs (OSSD)
• Input current High	mA	$I_{peak} \geq 5$		$I_{peak} \geq 5$		
Assignment of inputs		<ul style="list-style-type: none"> • Pin 1 and Pin 2: Connection/switching contact • Pin 3 and Pin 4: Connection/switching contact • Pin 5: Not assigned 		<ul style="list-style-type: none"> • Pin 1 and Pin 2: Connection/switching contact • Pin 3 and Pin 4: Connection/switching contact • Pin 5: Not assigned 		<ul style="list-style-type: none"> • Type 2 receiver: Pin 1/4/7: - Pin 2/3: + Pin 5: CH1 Pin 6: CH2 Pin 8: FE • Type 4 receiver: Pin 1/4 diag Pin 2/3: + Pin 5: CH1 Pin 6: CH2 Pin 7: - Pin 8: FE • Type 2/4, alternative receiver (5-pole): Pin 1: + Pin 2: CH2 Pin 3: - Pin 4: CH1 Pin 5: FE • Type 2/4 transmitter: Pin 1/4: + Pin 3: - Pin 5: FE
Outputs						
• Type of output	--			Solid-state		--
• Current carrying capacity A per output DC 12/13 typical	--			0.15	0.7	--
• Maximum summation current per module	A	--		0.15	1.4	--
• Socket assignment of outputs	--			<ul style="list-style-type: none"> • Pin 3: "-- • Pin 4: Output • Pin 5: Not assigned 		--
• Short-circuit protection	--			Built-in		--
• Induction protection	--			Built-in		--
• External power supply 24 V DC	--			--	Using black AS-Interface flat cable	--
• Watchdog	--			Built-in		--
Assignment of outputs						
• OUT 1 (D0)	--			Socket 3 - Pin 4		--
• OUT 2 (D1)	--			Socket 4 - Pin 4		--
AS-Interface certificate	Yes			Yes		

AS-Interface

ASIsafe

AS-Interface safety modules

	K20F compact safety modules		K45F compact safety modules			
	2 inputs, safe	2 inputs, safe	4 inputs, safe	2 inputs, safe	2 inputs, safe	2 inputs, safe, BWS for 1 light curtain
	--	--	--	2 outputs, standard	2 outputs, standard with U_{aux}	2 F-DI (solid-state, LS - light sensor)
	2 F-DI	2 F-DI	4 F-DI	2 F-DI/2 DO	2 F-DI/2 DO with U_{aux}	3RK1 205-0BQ21-0AA3 LS type 2
	3RK1 205-0BQ30-0AA3	3RK1 205-0BQ00-0AA3	3RK1 205-0BQ00-0AA3	3RK1 405-0BQ20-0AA3	3RK1 405-1BQ20-0AA3	3RK1 205-0BQ24-0AA3 LS type 4
Approvals	UL, CSA under application		UL, CSA		UL, CSA	
Degree of protection	IP65/67			IP65/67		
Ground terminal	--			--		Pin 5 or 8: Sensor grounding FE: Grounding lug
Ambient temperature	°C -25 ... +70			-25 ... +70		
Storage temperature	°C -40 ... +85			-40 ... +85		
Number of I/O sockets	2			4		2 Transmitter to bottom right socket, receiver (8-pole) to top right socket (Siemens 3RG7843/46), receiver (5-pole) to top left socket
Status displays	Yellow LED Not required Green/red LED			Yellow LED Not required Green/red LED		Green LED Not required
<ul style="list-style-type: none"> • Display of I/Os • U_{aux} • Display of AS-Interface/ diagnostics 						
Connection	Using M12 feeder		Using mounting plate for K45 compact module		Using mounting plate for K45 compact module	

	S22.5F SlimLine safety module, with screw-type or spring-type terminal		
	2 inputs, safe		
	--	2 outputs, standard	2 outputs, standard with U_{aux}
	2 F-DI	2 F-DI/2 DO	2 F-DI/2 DO with U_{aux}
	3RK1 205-0BE00-0AA2	3RK1 405-0BE00-0AA2	3RK1 405-1BE00-0AA2
	3RK1 205-0BG00-0AA2	3RK1 405-0BG00-0AA2	3RK1 405-1BG00-0AA2
<ul style="list-style-type: none"> • Screw terminals  • Spring-type terminals  			
AS-Interface chip	SAP 5	SAP 5	SAP 5
I/O configuration	0	7	7
ID/ID2 code	B/F	B/F	B/F
PFD value	Makes no notable contribution to the PFD of the overall system, comprised of the AS-Interface bus and safety monitor	Makes no notable contribution to the PFD of the overall system, comprised of the AS-Interface bus and safety monitor	Makes no notable contribution to the PFD of the overall system, comprised of the AS-Interface bus and safety monitor
Operational voltage according to AS-Interface specification	V 26.5 ... 31.5	26.5 ... 31.5	26.5 ... 31.5
Total current input	mA ≤ 45	≤ 250	≤ 60
Inputs			
<ul style="list-style-type: none"> • Sensors • Input current Low • Input current High 	Mechanical switching contact mA Contact open mA Contact closed $I_{peak} \geq 5$	Mechanical switching contact Contact open Contact closed $I_{peak} \geq 5$	Mechanical switching contact Contact open Contact closed $I_{peak} \geq 5$
Assignment of inputs	<ul style="list-style-type: none"> • F-IN1.1 and F-IN1.2: Connection of switching contact • F-IN2.1 and F-IN2.2: Connection of switching contact 	<ul style="list-style-type: none"> • F-IN1.1 and F-IN1.2: Connection of switching contact • F-IN2.1 and F-IN2.2: Connection of switching contact 	<ul style="list-style-type: none"> • F-IN1.1 and F-IN1.2: Connection of switching contact • F-IN2.1 and F-IN2.2: Connection of switching contact

S22.5F SlimLine safety module, with screw-type or spring-type terminal			
2 inputs, safe			
		2 outputs, standard	2 outputs, standard with U_{aux}
	--	2 F-DI/2 DO	2 F-DI/2 DO with U_{aux}
Screw terminals	3RK1 205-0BE00-0AA2	3RK1 405-0BE00-0AA2	3RK1 405-1BE00-0AA2
Spring-type terminals	3RK1 205-0BG00-0AA2	3RK1 405-0BG00-0AA2	3RK1 405-1BG00-0AA2
Outputs			
• Type of output	--	Solid-state	Solid-state
• Current carrying capacity A per output DC 12/13 typical	--	0.15	0.7
• Maximum summation current per module	A --	Max. 0.15	Max. 1.4
• Short-circuit protection	--	Built-in	Built-in
• Induction protection	--	Built-in	Built-in
• External power supply 24 V DC	--	--	Using black AS-Interface flat cable
• Watchdog	--	Built-in	Built-in
• Wiring of outputs	--	See section Schematics/Wiring – SlimLine Safety Module S22.5F	See section Schematics/Wiring – SlimLine Safety Module S22.5F
• Assignment of outputs	--	D0	D0
- OUT 1	--	D1	D1
- OUT 2	--		
AS-Interface certificate	Yes	Under application	Under application
Approvals	UL, CSA	UL, CSA	UL, CSA
Mechanical specifications			
• Degree of protection	IP20	IP20	IP20
• Shock load (IEC 60068-2-6)	g/ms 15/11	15/11	15/11
• Vibratory load (IEC 60068-2-27)	Hz 5 ... 500 Hz 5 ... 26: 0.75 mm amplitude Hz 26 ... 500: 2 g	5 ... 500 5 ... 26: 0.75 mm amplitude 26 ... 500: 2 g	5 ... 500 5 ... 26: 0.75 mm amplitude 26 ... 500: 2 g
Ground terminal	--	--	--
Ambient temperature	°C -25 ... +70	-25 ... +70	-25 ... +70
Storage temperature	°C -40 ... +85	-40 ... +85	-40 ... +85
Number of I/O sockets	--	--	--
Status displays			
• Display of I/Os	Yellow LED	Yellow LED	Yellow LED
• U_{aux}	--	--	Green LED
• Display of AS-Interface/diagnostics	Green/red LED	Green/red LED	Green/red LED
Connection	Using screw terminals or spring-type terminals	Using screw terminals or spring-type terminals	Using screw terminals or spring-type terminals

Dimensional drawings

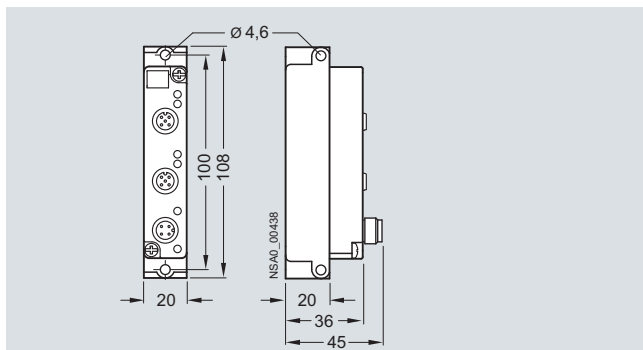

K20 module, two safe inputs, M12 (3RK1 205-0BQ30-0AA3)

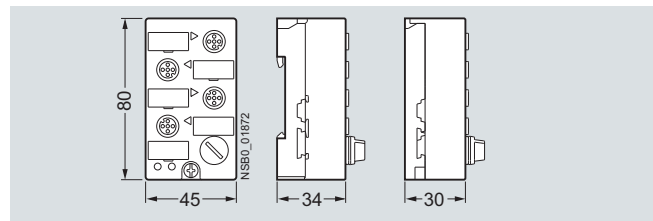

K45F compact safe module:
 3RK1 205-0BQ00-0AA3, 3RK1 205-0CQ00-0AA3,
 3RK1 405-0BQ20-0AA3, 3RK1 405-1BQ20-0AA3,
 3RK1 205-0BQ21-0AA3, 3RK1 205-0BQ24-0AA3

AS-Interface

ASIsafe

AS-Interface safety modules

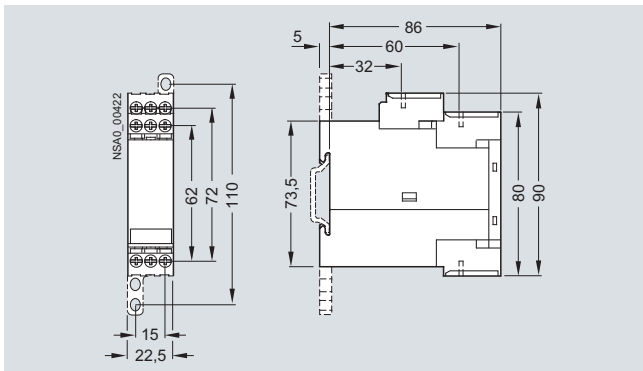

S22.5F SlimLine safety module, 2 F-DI, screw terminals
3RK1 205-0BE00-0AA2

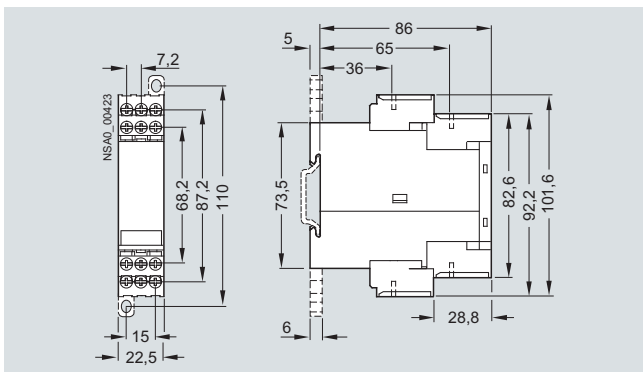

S22.5F SlimLine safety module, 2 F-DI/2 DO, screw terminals
3RK1 405-0BE00-0AA2 (without U_{aux})
3RK1 405-1BE00-0AA2 (with U_{aux})

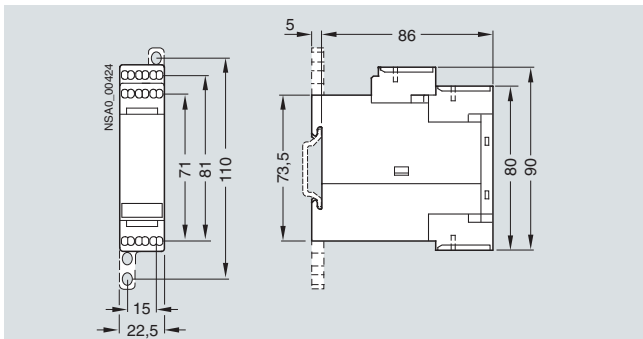

S22.5F SlimLine safety module, 2 F-DI, spring-type terminals
3RK1 205-0BG00-0AA2

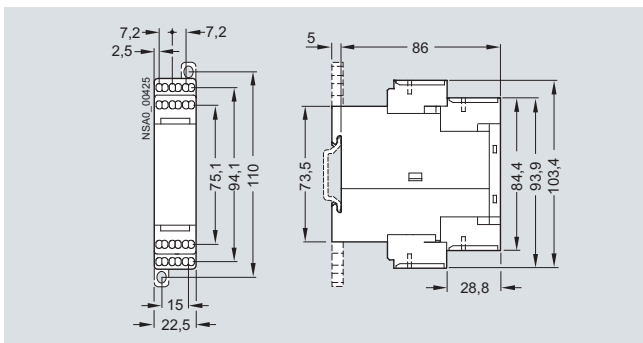

S22.5F SlimLine safety module, 2 F-DI/2 DO, spring-type terminals
3RK1 405-0BG00-0AA2 (without U_{aux})
3RK1 405-1BG00-0AA2 (with U_{aux})

Schematics

Logical assignments - K45F compact safety module

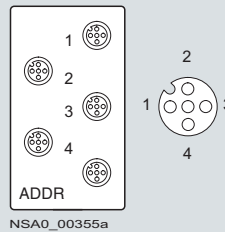

Socket	Assignment / data sheets / function
1	Pin 1 and Pin 2: Influences the bits D0 and D1 = Channel 1 Pin 3 and Pin 4: Influences the bits D2 and D3 = Channel 2 Pin 5 not assigned
2	Pin 1 and Pin 2: Influences the bits D2 and D3 = Channel 2 Pin 5 not assigned
3	Not assigned
4	Not assigned

If only a single-channel switch is to be connected to the module, it must be connected to Channel 1. The second channel must be bridged. This is done with the M12 plug 3RK1 901-1AA00 at socket 2.

Pin 3 of socket 1 is connected to Pin 1 of socket 2, and Pin 4 of socket 1 is connected to Pin 2 of socket 2. If both pairs of sockets are assigned, the inputs are linked.

Logical assignments - K45F LS compact safety module

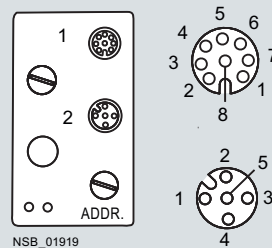

Socket	Assignment/data sheets/function
1	Type 2 receiver: Pin 1/4/7: - Pin 2/3: + Pin 5: CH1 Pin 6: CH2 Pin 8: FE Type 4 receiver: Pin 1/4 Diag Pin 2/3: + Pin 5: CH1 Pin 6: CH2 Pin 7: - Pin 8: FE
2	Type 2/4, alternatively receiver (5-pole): Pin 1: + Pin 2: CH2 Pin 3: - Pin 4: CH1 Pin 5: FE Type 2/4 transmitter: Pin 1/4: + Pin 3: - Pin 5: FE

AS-Interface safety modules

Logical assignments - K20F compact safety module

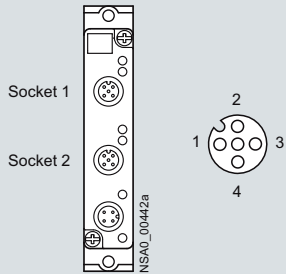

Socket	Assignment / data sheets / function
1	Pin 1 and Pin 2: Influences the bits D0 and D1 = Channel 1 Pin 3 and Pin 4: Influences the bits D2 and D3 = Channel 2 Pin 5 not assigned
2	Pin 1 and Pin 2: Influences the bits D2 and D3 = Channel 2 Pin 3, Pin 4 and Pin 5 not assigned

If only a single-channel switch is to be connected to the module, it must be connected to Channel 1. The second channel must be bridged. This is done with the M12 plug 3RK1 901-1AA00 at socket 2.

Pin 3 of socket 1 is connected to Pin 1 of socket 2, and Pin 4 of socket 1 is connected to Pin 2 of socket 2. If both pairs of sockets are assigned, the inputs are linked.

Wiring – S22.5F SlimLine safety module

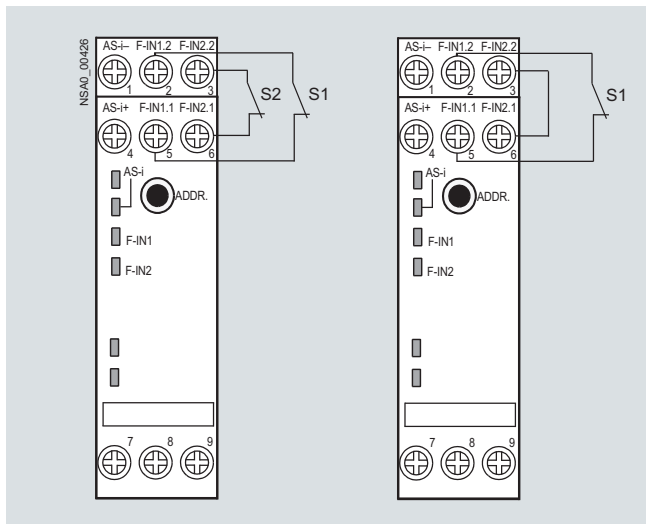

Wiring for S22.5F SlimLine safety module, 2F-DI, Category 2 (right) and Category 4 (left)
3RK1 205-0BE00-0AA2 (screw terminals)
3RK1 205-0BG00-0AA2 (spring-type terminals)

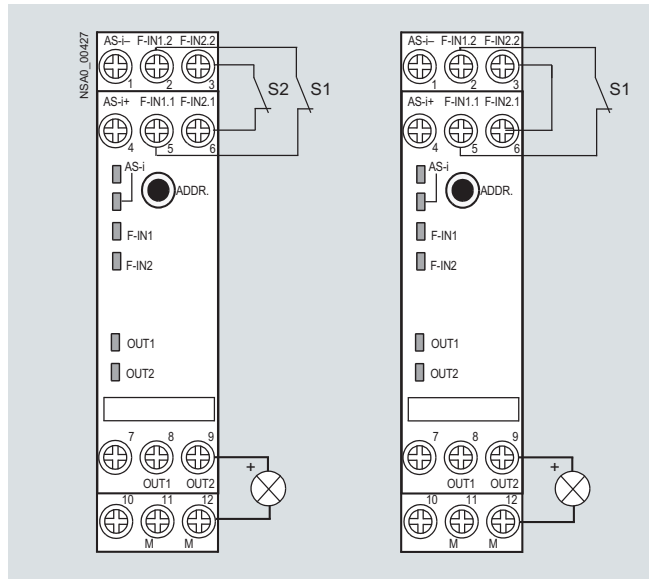

Wiring for S22.5F SlimLine safety module, 2F-DI/2 DO without U_{aux} , Category 2 (right) and Category 4 (left)
3RK1 405-0BE00-0AA2 (screw terminals)
3RK1 405-0BG00-0AA2 (spring-type terminals)

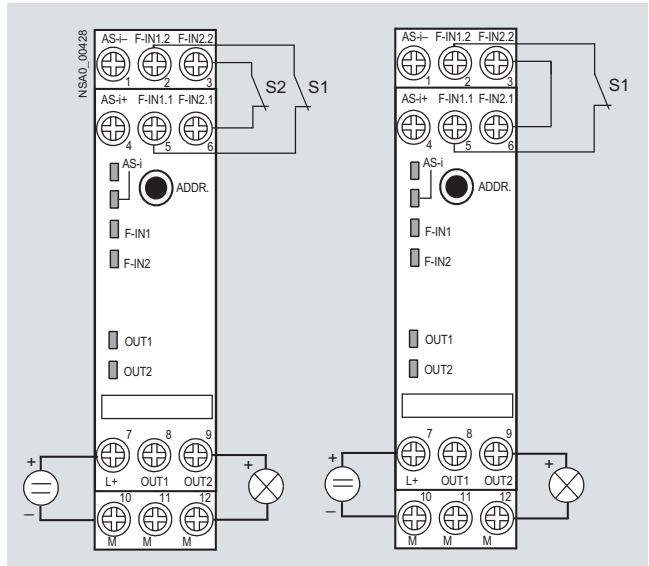

Wiring for S22.5F SlimLine safety module, 2F-DI/2 DO with U_{aux} , Category 2 (right) and Category 4 (left)
3RK1 405-1BE00-0AA2 (screw terminals)
3RK1 405-1BG00-0AA2 (spring-type terminals)

AS-Interface

Masters

CP 142-2

Overview



CP 142-2

- AS-Interface master connection for the ET 200X distributed peripherals system
- Easy operation in the input/output address range of the SIMATIC ET 200X
- No configuration of the CP for AS-Interface required
- Actuating up to 31 AS-Interface slaves according to AS-Interface specification V2.0
- Monitoring of the supply voltage on the AS-Interface cable
- Distinct increase in the number of inputs/outputs of the ET 200X

Design

- 16-byte inputs and 16-byte outputs are used in the address area of the ET 200X
- Status displays of the operating states by means of LEDs in the front panel
- Indication of the connected slaves and activated slaves and their readiness for operation by means of LEDs
- One pushbutton for switching over the operating state, for adopting the existing configuration and for switching over the display
- Connection of AS-Interface cable to M12 plug
- Monitoring of the power supply on the AS-Interface cable

Function

The CP 142-2 can be used in two operating modes:

- Standard operation with BM 141/BM 142/BM 147
- At most the 124 input and output bits of the AS-Interface slaves can respond.
- Expanded operation with BM 147
An FC (Function Call) enables master invocations according to AS-Interface specification V2.0 (e. g. write parameters). The invocations are described in the manual. The manual comes with program examples.

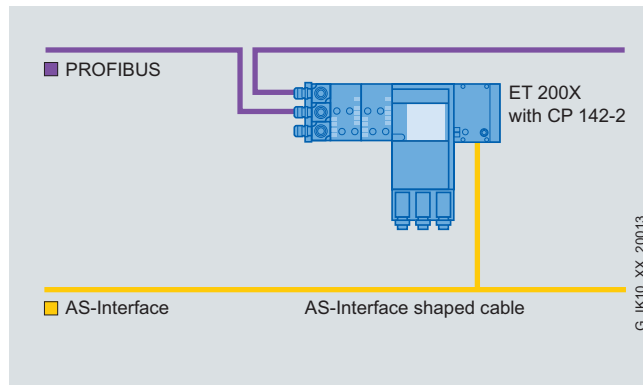

Example of configuration

Configuration

Parameterization of the CP 142-2 is performed with the STEP 7 basic package, version V2.1 and higher. No further configuration is required for AS-Interface.

Technical specifications

AS-Interface specification	V 2.0	
• With BM 141/BM 142	Only I/O transmission	
• With BM 147 and FC ASI_3422	All functions	
Bus cycle time	ms	5 with 31 slaves
Configuration	<ul style="list-style-type: none"> • AS-Interface: Using pushbutton on the front panel • PROFIBUS: In the PROFIBUS configuration of the ET 200X, the CP 142-2 occupies 16-byte inputs and 16-byte outputs 	
Connection of the AS-Interface cable	Using M12 plug on the front panel cable	
Address size	16 input bytes 16 output bytes	
Supply voltage	<ul style="list-style-type: none"> • From electronics/sensor supply V DC voltage of the ET 200X (1L+) • From AS-Interface cable 	
Power loss	W	2
Power consumption	<ul style="list-style-type: none"> • From supply voltage 24 V DC • From AS-Interface cable 	
Permissible ambient conditions	<ul style="list-style-type: none"> • Operating temperature • Transport/storage temperature • Relative humidity 	
Structural design	ET 200X mounting method	
• Module format	Expansion module	
• Dimensions (W x H x D)	mm	87 x 110 x 63
• Weight	g	Approx. 310
• Space requirement	1 mounting space	

Overview



The CP 243-2 is the AS-Interface master for the SIMATIC S7-200. This communications processor (6GK1 243-2AX01-0AX0) supports the extended AS-Interface specification V2.1 and performs the following functions:

- Connection of up to 62 AS-Interface slaves and integrated analog value transmission (according to the extended AS-Interface specification V2.1)
- Supports all AS-Interface master functions according to the extended AS-Interface specification V2.1
- Status displays of operating states and indication of the readiness for operation of connected slaves by means of LEDs in the front panel
- Fault indications (e. g. AS-Interface voltage fault, configuration fault) by means of LEDs in the front panel
- Compact enclosure in the design of the SIMATIC S7-200

Design

The CP 243-2 is connected like an expansion module to the S7-200. It has:

- Two terminal connections for direct connection of the AS-Interface cable
- LEDs in the front panel for indicating the operating state and functional readiness of all connected and activated slaves
- Two pushbuttons for indicating the status information of the slaves, for switching over the operating state and for adopting the existing ACTUAL configuration as the DESIRED configuration.

Function

The CP 243-2 supports all specified functions of the extended AS-Interface specification V2.1. This means that up to 62 digital or 31 analog slaves can be operated on the AS-Interface through expanded addressing (A/B).

Thanks to the integrated analog value processing it is just as easy to access the analog values as the digital values.

In the process image of the S7-200 the CP 243-2 occupies one digital input byte (status byte), one digital output byte (control byte), and 8 analog input and 8 analog output words. The CP 243-2 thus occupies two (logic) slots. The operating mode of the CP 243-2 can be set with the status byte and the control byte using the user program.

Depending on the operating mode the CP 243-2 saves either the digital or analog I/O data of the AS-Interface slaves or diagnostic values in the analog address area of the S7-200, or it enables master calls (e. g. re-addressing of the slaves).

Configuration

All connected AS-Interface slaves are configured at the press of a button. No further configuration of the CP is required.

Technical specifications

AS-Interface specification	V 2.1	
Bus cycle time	ms	5 with 31 slaves 10 with 62 slaves
Interfaces	<ul style="list-style-type: none"> • Assignment of address area in AG: 16 bytes AE/AA, 1 byte DE/DA • AS-Interface connection: Screw terminals 	
Power consumption	<ul style="list-style-type: none"> • Using backplane bus: mA Max. 220 at 5 V DC • From AS-Interface cable: mA Max. 100 	
Power loss	W	Approx. 2
Permissible ambient conditions	<ul style="list-style-type: none"> • Operating temperature <ul style="list-style-type: none"> - Horizontal installation: °C 0 ... +55 - Vertical installation: °C 0 ... +45 • Transport/storage temperature: °C -40 ... +70 • Relative humidity: % Max. 95 at +25 °C 	
Structural design	<ul style="list-style-type: none"> • Module format: S7-22x expansion module • Dimensions (W x H x D): mm 71 x 80 x 62 (H+16 mm with holes for wall mounting) • Weight: g 250 • Space requirement: 1 mounting space 	

AS-Interface Masters

CP 343-2

Overview



The CP 343-2 is the AS-Interface master for the SIMATIC S7-300 programmable controller and the ET 200M distributed I/O station. The communications processor performs the following functions:

- Connection of up to 62 AS-Interface slaves and integrated analog value transmission (according to the AS-Interface Specification V3.0)
- Supports all AS-Interface master functions according to the AS-Interface Specification V3.0
- Status displays of operating states and indication of the readiness for operation of connected slaves by means of LEDs in the front panel
- Fault indications (e. g. AS-Interface voltage fault, configuration fault) by means of LEDs in the front panel

Design

The CP 343-2 is connected like an expansion module to the S7-300. It has:

- Two terminal connections for direct connection of the AS-Interface cable
- LEDs in the front panel for indicating the operating state and functional readiness of all connected and activated slaves
- Pushbuttons for indicating the status information of the slaves, for switching over the operating state and for adopting the existing ACTUAL configuration as the DESIRED configuration.

Function

The CP 343-2 supports all specified functions of the AS-Interface specification V3.0. This means that up to 62 digital or analog slaves can be operated on the AS-Interface through expanded addressing (A/B). The integrated analog value processing permits easy access to the analog values.

The CP 343-2 occupies 16 bytes each in the I/O address area of the SIMATIC S7-300. The digital I/O data of the standard slaves and A slaves are saved in this area. The digital I/O data of the B slaves and the analog I/O data can be accessed with the S7 system functions for read/write data record. A slaves and B slaves are slaves according to AS-Interface Specification V2.1 and V3.0.

If required, master calls can be performed with the command interface FC ASI_3422, e. g. read/write parameters, read/write configuration.

The FC including a STEP7 sample program can be downloaded from the Internet at <http://support.automation.siemens.com/WWW/view/en/5581657>.

Configuration

All connected AS-Interface slaves are configured at the press of a button. No further configuration of the CP is required.

Technical specifications

AS-Interface specification		V3.0
Bus cycle time	ms	5 with 31 slaves 10 with 62 slaves
Interfaces		
• Assignment of address area in AG		16 bytes I/O
• AS-Interface connection		S7-300 front connector with terminal connection
Supply voltage	V DC	+5, using backplane bus
Power consumption		
• From backplane bus	mA	Max. 200 at 5 V DC
• From AS-Interface cable	mA	Max. 100
Power loss	W	2
Permissible ambient conditions		
• Operating temperature	°C	0 ... +60
• Transport/storage temperature	°C	-40 ... +70
• Relative humidity, max.	%	95 at +25 °C
Structural design		
• Module format		S7-300 design
• Dimensions (W x H x D)	mm	40 x 125 x 120
• Weight	g	190
• Space requirement		1 mounting space

Overview



The CP 343-2P is the AS-Interface master for the SIMATIC S7-300 programmable controller and the ET 200M distributed I/O station. The communications processor performs the following functions:

- **Supports the configuration of the AS-Interface-network with STEP 7 V5.2 and higher**
- Connection of up to 62 AS-Interface slaves and integrated analog value transmission (according to the AS-Interface Specification V3.0)
- Supports all AS-Interface master functions according to the AS-Interface Specification V3.0
- Fault indications (e. g. AS-Interface voltage fault, configuration fault) by means of LEDs in the front panel
- Compact enclosure in the design of the SIMATIC S7-300

Design

The CP 343-2P is connected like an expansion module to the S7-300. It has:

- Two terminal connections for direct connection of the AS-Interface cable
- LEDs in the front panel for indicating the operating state and the readiness for operation of all connected and activated slaves
- Pushbuttons for indicating the status information of the slaves, for switching over the operating state and for adopting the existing ACTUAL configuration as the DESIRED configuration.

Function

The CP 343-2P supports all specified functions of the AS-Interface specification V3.0. This means that up to 62 digital or analog slaves can be operated on the AS-Interface through expanded addressing (A/B). The integrated analog value processing permits easy access to the analog values.

The CP 343-2P occupies 16 bytes each in the I/O address area of the SIMATIC S7-300. The digital I/O data of the standard slaves and A slaves are saved in this area. The digital I/O data of the B slaves and the analog I/O data can be accessed with the S7 system functions for read/write data record. A slaves and B slaves are slaves according to AS-Interface Specification V2.1 and V3.0.

If required, master calls can be performed with the command interface FC ASI_3422, e. g. read/write parameters, read/write configuration. The FC including a STEP7 sample program can be downloaded from the Internet at <http://support.automation.siemens.com/WWW/view/en/5581657>

Configuration

All connected AS-Interface slaves are configured at the press of a button. No further configuration of the CP is required.

The CP 343-2P also supports configuring of the AS-Interface network with STEP 7 V5.2 and higher. Specifying the AS-i configuration in HW-Config facilitates the setting of slave parameters and documentation of the plant. In particular the user-friendly configuring of Siemens AS-Interface slaves using the slave selection dialog is possible. Uploading the ACTUAL configuration of an already configured AS-Interface network is also supported. The saved configuration cannot be overwritten at the press of a button and is therefore tamper-proof.

Technical specifications

AS-Interface specification	V3.0	
Bus cycle time	ms	5 with 31 slaves 10 with 62 slaves
Interfaces	<ul style="list-style-type: none"> • Assignment of address area in AG • AS-Interface connection 	
Supply voltage	V DC	+5, using backplane bus
Power consumption	<ul style="list-style-type: none"> • From backplane bus • Using AS-Interface from the AS-Interface shaped cables 	
Power loss	W	2
Permissible ambient conditions	<ul style="list-style-type: none"> • Operating temperature • Transport/storage temperature • Relative humidity, max. 	
Structural design	<ul style="list-style-type: none"> • Module format • Dimensions (W x H x D) • Weight • Space requirement 	
Configuration software	Optional: STEP 7 V5.2 and higher	

AS-Interface Routers

DP/AS-i F-Link

Overview



PN	DP-M	DP-S	ASi-M
		■	■

- Compact, safety-oriented router between PROFIBUS (DP Slave) and AS-Interface
- Monitoring the inputs of safety-oriented digital AS-i slaves (ASIsafe slaves) and forwarding of data through PROFIsafe. No additional safety-oriented components required for the AS-Interface (e. g. safety monitor)
- AS-i master according to AS-Interface Specification V3.0, master profile M4, for connection of up to 62 AS-i slaves with integrated analog value transmission function
- Direct integration in PROFIBUS networks. Optional integration in PROFINET environments through PROFINET/PROFIBUS gateway (IE/PB Link PN IO) or through SIMATIC S7 315/317/319 F PN/DP or S7-416F-3 PN/DP
- Connection to ET 200S with IM-F-CPU using DP master module is possible
- Optimum TIA integration in STEP 7 using Object Manager, integration in non-Siemens engineering tools using PROFIBUS GSD file
- Local diagnostics using LEDs and display with control keys

Design

- Rugged, slim plastic enclosure, degree of protection IP20, for standard rail mounting or wall mounting (with adapter)
- Compact design:
 - Front display for indication of the operating state and readiness for operation of all connected AS-Interface slaves
 - 2 buttons on the front for start-up, call up of diagnostic information
 - 4 LEDs for indication of the operating state of the device, of PROFIBUS DP and the AS-Interface network
 - Front PROFIBUS DP connection with sub D connector
 - Removable terminal blocks for connection of AS-i +/- and supply voltage (over 24 V DC PELV power supply unit)
 - Narrow width (45 mm)
- Simple mounting on standard rail or on the wall (with adapter)
- Operation without fans and batteries
- Fast device replacement in the event of a fault

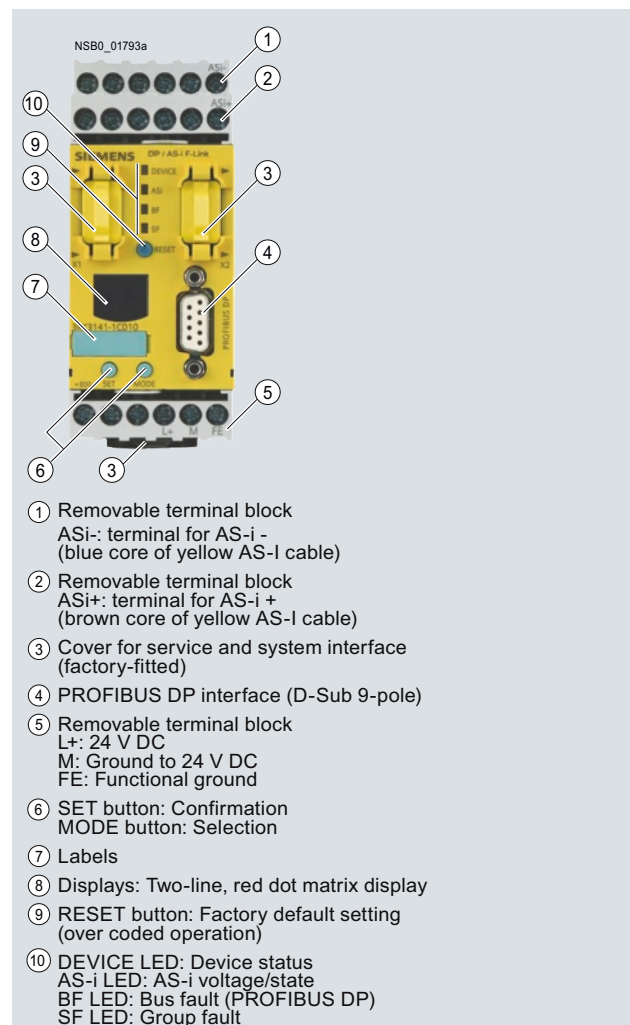

- 1 Removable terminal block
ASi-: terminal for AS-i -
(blue core of yellow AS-I cable)
- 2 Removable terminal block
ASi+: terminal for AS-i +
(brown core of yellow AS-I cable)
- 3 Cover for service and system interface
(factory-fitted)
- 4 PROFIBUS DP interface (D-Sub 9-pole)
- 5 Removable terminal block
L+: 24 V DC
M: Ground to 24 V DC
FE: Functional ground
- 6 SET button: Confirmation
MODE button: Selection
- 7 Labels
- 8 Displays: Two-line, red dot matrix display
- 9 RESET button: Factory default setting
(over coded operation)
- 10 DEVICE LED: Device status
AS-i LED: AS-i voltage/state
BF LED: Bus fault (PROFIBUS DP)
SF LED: Group fault

Front view of DP/AS-i F-Link

Function

Communication principle

The PROFIBUS DP master or the safe control communicates with the AS-Interface slaves over the DP/AS-i F-Link. The AS-Interface communication objects are mapped in a contiguous data storage area for non-failsafe input and output data and a separate data storage area for PROFIsafe data in the PROFIBUS DP master. The DP/AS-i F-Link manages two interfaces:

- Interface to the PROFIBUS DP master: PROFIBUS DP
- Interface to the AS-Interface slaves: AS-Interface

Diagnostics

Extensive diagnostics is possible using the four LEDs, display and control keys or SIMATIC S7. Further details can be found in the manual.

Configuration

The DP/AS-i F-Link can be configured by means of STEP 7 Version V5.4 SP1 and higher. As a startup aid it is also possible to adopt the actual configuration directly on the device

When configuring STEP 7, the AS-Interface configuration can be uploaded in STEP 7 HW-Config, STEP 7 V5.4 SP1 and higher.

Alternatively, DP/AS-i F-Link can be integrated in the engineering tool using the PROFIBUS GSD file.

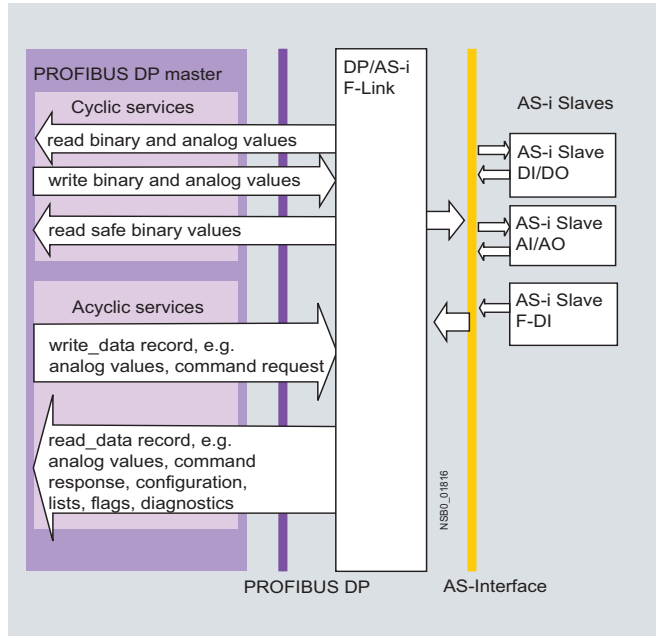

Communication principle for data exchange between PROFIBUS DP master and AS-Interface slaves

AS-i...	Baugruppe	Bestellnummer	E-Adres..	A-Adre...	F...	F...	I...	I...	P...	Ko...
	F-Link (PROFIsafe)		12...43	12...43	0...11	0...3				
	DP/AS-i									
	DP/AS-i F-Link	3RK3 141-xCD10								
1A	AS-isafe K20F, 2F-DI	3RK1 205-0BQ30-0AA3	12.0..12.3		0.1		0.B.0F		F	
B										
2A	AS-i Standard Slave	AS-i Standard Slave Univers	14.4..14.6	13.3..13.6			E.0.FF		F	
B										
3A	AS-i A/B Slave	AS-i A/B Slave Universal	13.6	14.0..14.2			A.A.00		7	
B	AS-i K45, 2DI/2DO, A/B	3RK2 400-1BQ20-0AA3	13.0..13.1	12.0..12.1			B.A.0F		7	
4A	AS-i K60, 4AI-C	3RK1 207-1BQ44-0AA3	256..263				7.3.EF		9	
B										
5A	AS-i K60, 4DI/4DO, A/B	3RK2 400-1DQ00-0AA3	13.2..13.5	13.0..13.3			7.A.77		7	
B										
6A	AS-isafe FS400 RCV-M	3SF78 44-xMxxx-xxx1	14.0..14.3		0.6		0.B.FF		F	
B										
7A	AS-isafe F-ADAPTER	3SF5 402-1AR03	15.0..15.3	12.2..12.5	0.7		7.B.0F		F	
B										
8A	AS-isafe K45F, 2F-DI/2DO	3RK1 405-1BQ20-0AA3	15.3..15.6	12.3..12.6	1.0		7.B.FF		7	
B										
9A	AS-isafe K20F, 2F-DI	3RK1 205-0BQ30-0AA3	16.0..16.3		1.1		0.B.0F		7	
B										
10A										
B										
11A										
C										

Configuration: AS-Interface address table assigned with AS-Interface slaves

AS-Interface

Routers

DP/AS-i F-Link

User-friendly configuring of Siemens AS-Interface slaves in HW-Config is also possible in this case (slave catalog).

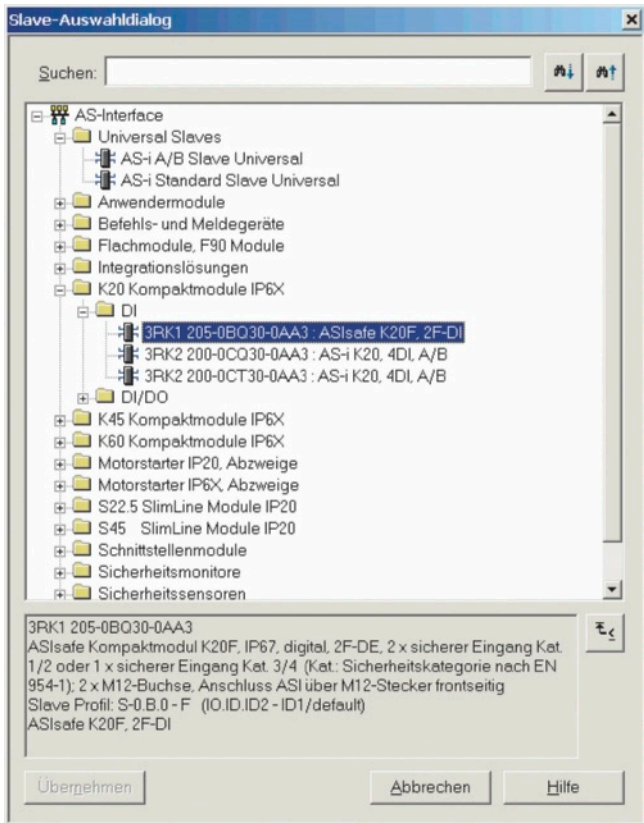

Configuration: Slave selection dialog

Programming

In contrast to the AS-Interface safety monitor, the DP/AS-i F-Link functions solely as a gateway, and does not process its own safety logic.

Programming of the safety function is implemented at the level of the higher-level failsafe PLC, e. g.:

- With Distributed Safety, Version V5.4 SP1 or higher for SIMATIC S7-300F/416F
- With the SAFETY INTEGRATED "SI-Basic" or "SI-COMFORT" NCU Software for SINUMERIK 840D pl/sl

Technical specifications

Transmission rates per AS-Interface line		
• AS-Interface bus cycle time	ms	5 (for 31 slaves) 10 (for 62 slaves, or acc. to AS-Interface Specification V3.0)
• PROFIBUS transmission rate	Mbit/s	Max. 12
Interfaces		
• AS-Interface connection		Over removable terminal blocks (with screw or spring-type terminals)
• Connection to PROFIBUS		1 x 9-pole Sub D socket
• 24 V DC supply voltage (PELV)		3-pole clamping contacts including functional ground, over removable terminal blocks (with screw or spring-type terminals)
Display		2 lines à 4 characters (red LED dot matrix)
Operation		Over three buttons (Set/Mode/Reset)
Supply voltage		
• From AS-Interface		Acc. to AS-Interface Specification V3.0
• 24 V DC (PELV)	V DC	24, functional ground
Power consumption		
• From 24 V DC	mA	Max. 110
Degree of protection		IP20
Permissible ambient conditions		
• Operating temperature	°C	0 ... +60
• Transport and storage temperature	°C	-40 ... +85
• Relative humidity	%	Max. 95 (at +25 °C)
• Operating altitude	m above sea level	2000
Structural design		
• Mounting		Onto standard mounting rail or wall mounting (with adapter)
• Dimensions (W x H x D)	mm	45 x 104 x 120
• Weight	g	Approx. 300
Supported AS-Interface master profile		M4 (acc. to AS-Interface Specification V3.0)
Configuration of DP/AS-i F-Link and the AS-Interface slaves		Using buttons on the front panel With STEP 7, Version V5.4 SP1 or higher for SIMATIC S7-300F/416F With GSD
Programming of safety functions		With Distributed Safety, Version V5.4 SP1 or higher for SIMATIC S7-300F/416F With the SAFETY INTEGRATED "SI-Basic" or "SI-COMFORT" NCU Software for SINUMERIK 840D pl/sl
Approvals		CE, TÜV, UL AS-Interface certificate

More information

The manual DP/AS-i F-Link can be downloaded free of charge from the Internet at <http://support.automation.siemens.com/WW/view/en/24196041>.

More presales information can be found at <http://www.siemens.com/as-interface/master>.

Overview

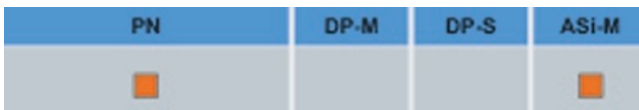

- Compact router between Industrial PROFINET/Industrial Ethernet and AS-Interface
- Single and double AS-Interface master (according to AS-Interface Specification V3.0) for connection of 62 AS-Interface slaves each and integrated analog value transmission
- Performant, integrated analog value transmission
- Integrated ground-fault monitoring for the AS-Interface cable
- User-friendly local diagnostics and start-up by means of a full graphic display and control keys or through a web interface with a standard browser
- Optimum TIA integration through STEP 7, integration in non-Siemens engineering tools using PROFINET type file (GSD)
- Vertical integration (standard web interface) through Industrial Ethernet
- Supply voltage from the AS-Interface shaped cable or alternatively with 24 V DC
- Module exchange without entering the connection parameters (IP address etc) using C-PLUG (optional)
- Costs saved by the double AS-Interface master when large volumes of project data are involved

Design

- Compact plastic enclosure in degree of protection IP20 for standard rail mounting
- Compact design;
 - Display in the front panel for detailed indication of the operating state and readiness for operation of all connected and activated AS-Interface slaves
 - Six pushbuttons for starting up and testing the AS-Interface line directly on the IE/AS-i LINK PN IO
 - LED indication of the operating state of PROFINET IO and AS-Interface
 - Integrated 2-port switch (RJ45 socket) for connection to Industrial Ethernet supports the line topology with an external switch
 - User-friendly start-up, diagnostics and testing of IE/AS-i LINK PN IO through a web interface using a standard browser
 - Supply voltage from the AS-Interface shaped cable or alternatively with 24 V DC
 - Small mounting depth thanks to recessed plug mounting
- Simple mounting on standard mounting rail
- Operation without fans and batteries
- Fast exchange of devices with the help of the optional C-PLUG exchange medium (not included in scope of supply)

AS-Interface Routers

IE/AS-i LINK PN IO

Function

The IE/AS-i LINK PN IO enables a PROFINET IO controller to cyclically access the I/O data of all the slaves of a lower-level AS-Interface segment. According to the extended AS-Interface specification (V3.0) up to 62 slaves, each with 4 digital inputs and 4 digital outputs as well as analog slaves, can now be connected per AS-Interface line. Also supported are the expanded slave types with higher I/O data volume according to AS-i Specification V3.0.

IE/AS-i LINK PN IO occupies as standard 62 bytes of input data and 62 bytes of output data in the IO controller in which the I/O data of the connected AS-Interface slaves of an AS-i line are stored. The double master occupies twice the number of bytes. The size of the input/output buffer can be compressed so that only the actually required I/O memory space is occupied in the system of the IO controller. The integrated evaluation of analog signals is just as easy as accessing digital values.

PROFINET IO controllers are able in addition to initiate AS-Interface master calls (e. g. to write parameters, change addresses, read diagnostic values) through the acyclic PROFINET services.

Using an operating display in AS-Interface Link it is possible to fully commission the lower-level AS-i line. IE/AS-i LINK PN IO is equipped with two switched Ethernet ports which enable use of the integrated web server and further increases the previously described user-friendliness of the operating display. Firmware updates are also possible.

The optional C-PLUG supports module exchange without entering the connection parameters (IP address etc.), keeping down-times to a minimum in the event of a fault.

Diagnostics

Extensive diagnostics is possible using the display and control keys, web interface or STEP 7, for example:

- Operating state of link
- Status of link as PROFINET IO device
- Diagnostics of the AS-Interface network
- Message frame statistics
- Standard diagnostics pages for fast access using a standard browser

Configuration

STEP 7 V5.4 or higher is required for configuring the full functional scope of the IE/AS-i LINK PN IO.

Alternatively, IE/AS-i LINK IO can be integrated by means of the PROFINET type file (GSD) in the engineering tool:

- STEP 7 version V5.4 SP2 and lower
- Non-Siemens engineering tools

With STEP 7 configuring, the AS-Interface configuration can be uploaded in STEP 7 V5.4 SP2 and higher. User-friendly configuring of Siemens AS-i slaves in HW-Config is also possible in this case (slave selection dialog).

Technical specifications

Transmission rates per AS-i line		
• AS-Interface bus cycle time	ms	5 with 31 slaves; 10 with 62 slaves
Ethernet transmission rate	Mbit/s	10/100, autosensing
Interfaces		
• AS-Interface connection		
- With single master		1 x 4-pole screw terminals (removable)
- With double master (2 AS-i lines)		2 x 4-pole screw terminals (removable)
• Connection to Ethernet		2 x RJ45 socket (switchports)
• Optional: 24 V DC supply voltage		3-pole screw terminals (removable) including connection of functional ground for integrated ground-fault monitoring
• Slot for exchange medium		C-PLUG
Display		128 x 64 pixel with background lighting
Keys		Membrane keyboard (6 keys)
Supply voltage		
• From AS-Interface cable (AS-i line 1)		Acc. to AS-Interface Specification EN 50295
• Optional	V DC	24 V, functional ground
Power consumption		
• From AS-Interface shaped cable	mA	Max. 250
Load capacity		
• Power loss	W	7.5
Degree of protection		
IP20		
Permissible ambient conditions		
• Operating temperature		
- Horizontal mounting	°C	0 ... +60
- Vertical mounting	°C	0 ... +45
• Transport and storage temperature	°C	-30 ... +70
• Relative humidity	%	Max. 95 at +25 °C
• Operating altitude	m	3000 above sea level
Structural design		
• Mounting		On standard mounting rail
• Dimensions (W x H x D)	mm	90 x 132 x 88.5
• Weight	g	About 380
Supported AS-Interface master profile		M4 (acc. to AS-Interface Specification V3.0)
Configuring the AS-Interface		Using pushbuttons on the front panel, with STEP 7 version V5.4 SP2 and higher, through web interface

Overview



PN	DP-M	DP-S	ASI-M
		■	■

- Compact router between PROFIBUS (DP Slave) and AS-Interface
- Single and double AS-Interface master (according to AS-Interface specification V3.0) for connection of 62 AS-Interface slaves
- Performant, integrated analog value transmission
- Integrated ground-fault monitoring for the AS-Interface cable
- User-friendly local diagnostics and start-up by means of a full graphic display and control keys or through a web interface with a standard browser
- Optimum TIA integration through STEP 7, integration in non-Siemens engineering tools using PROFIBUS type file (GSD)
- Vertical integration (standard web interface) through Industrial Ethernet
- Supply voltage from the AS-Interface shaped cable or alternatively with 24 V DC (optional)
- Module exchange without entering the connection parameters (PROFIBUS address etc.) using C-PLUG (optional)

Design

- Compact plastic enclosure in degree of protection IP20 for standard rail mounting
- Compact design;
 - Display in the front panel for detailed indication of the operating state and readiness for operation of all connected and activated AS-Interface slaves
 - 6 pushbuttons for starting up and testing the AS-Interface line directly on the DP/AS-i LINK Advanced
 - LED indication of the operating state of PROFIBUS DP and AS-Interface
 - Integrated Ethernet port (RJ45 socket) for user-friendly start-up, diagnostics and testing of DP/AS-i LINK Advanced through a web interface using a standard browser
 - Supply voltage from the AS-Interface cable or alternatively with 24 V DC
 - Small mounting depth thanks to recessed plug mounting
- Simple mounting on standard mounting rail
- Operation without fans and batteries
- Fast exchange of devices with the help of the optional C-PLUG exchange medium (not included in scope of supply)

AS-Interface

Routers

DP/AS-i LINK Advanced

Function

The DP/AS-i LINK Advanced enables a PROFIBUS DP master to cyclically access the I/O data of all the slaves of a lower-level AS-Interface segment. According to the extended AS-Interface specification (V3.0) up to 62 slaves, each with 4 digital inputs and 4 digital outputs as well as analog slaves, can now be connected per AS-Interface line. Also supported are the expanded slave types with higher I/O data volume according to AS-i Specification V3.0.

DP/AS-i LINK Advanced occupies as standard 32 bytes of input data and 32 bytes of output data in the DP master in which the I/O data of the connected digital AS-Interface slaves of an AS-i line are stored. The double master occupies twice the number of bytes. The size of the input/output buffer can be compressed so that only the actually required I/O memory space is occupied in the system of the DP master. The integrated evaluation of analog signals is just as easy as accessing digital values; there is no need to call any communication modules.

PROFIBUS DP V1 masters are able in addition to initiate AS-Interface master calls (e. g. to write parameters, change addresses, read diagnostic values) through the acyclic PROFIBUS services.

Using an operating display in AS-i Link it is possible to fully commission the lower-level AS-Interface line. DP/AS-i LINK Advanced is equipped with an additional Ethernet port which enable use of the integrated web server and further increases the previously described user-friendliness of the operating display. Firmware updates are also possible.

The optional C-PLUG supports module exchange without entering the connection parameters (PROFIBUS address etc.), keeping downtimes to a minimum in the event of a fault.

Diagnostics

Extensive diagnostics is possible using LEDs, the display and control keys, web interface or STEP 7, for example:

- Operating state of link
- Status of link as PROFIBUS DP slave
- Diagnostics of the AS-Interface network
- Message frame statistics
- Standard diagnostics pages for fast access using a standard browser

Configuration

DP/AS-i LINK Advanced can be configured either by means of STEP 7 version V5.4 and higher or simply by adopting the AS-Interface actual configuration on the display.

Alternatively, DP/AS-i LINK Advanced can be integrated by means of the PROFIBUS type file (GSD) in the engineering tool:

- STEP 7 version V5.4 and lower
- Non-Siemens engineering tools

With STEP 7 configuring, the AS-Interface configuration can be uploaded in STEP 7 V5.4 and higher. User-friendly configuring of Siemens AS-Interface slaves in HW-Config is also possible in this case (slave selection dialog).

Technical specifications

Transmission rates per AS-Interface line		
• AS-Interface bus cycle time	ms	5 with 31 slaves; 10 with 62 slaves
• PROFIBUS transmission rate	Mbit/s	Max. 12
• Ethernet transmission rate	Mbit/s	10/100, autosensing
Interfaces		
• AS-Interface connection		
- With single master		1 x 4-pole screw terminals (removable)
- With double master (2 AS-i lines)		2 x 4-pole screw terminals (removable)
• Connection to PROFIBUS		1 x 9-pole Sub D socket
• Connection to Ethernet		1 x RJ45
• Optional: 24 V DC supply voltage		3-pole screw terminals (removable) including connection of functional ground for integrated ground-fault monitoring
• Slot for exchange medium		C-PLUG
Display		128 x 64 pixel with background lighting
Keys		Membrane keyboard (6 keys)
Supply voltage		
• From AS-Interface cable (AS-i line 1)		Acc. to AS-Interface Specification EN 50295
• Optional	V DC	24, functional ground
Power consumption		
• From AS-Interface cable	mA	Max. 250
Load capacity		
• 5 V DC at PROFIBUS connection	mA	Max. 70
• Power loss	W	7.5
Degree of protection		IP20
Permissible ambient conditions		
• Operating temperature		
- Horizontal mounting	°C	0 ... +60
- Vertical mounting	°C	0 ... +45
• Transport and storage temperature	°C	-30 ... +70
• Relative humidity	%	Max. 95 at +25 °C
• Operating altitude	m	3000 above sea level
Structural design		
• Mounting		On standard mounting rail
• Dimensions (W x H x D)	mm	90 x 132 x 88.5
• Weight	g	About 380
Supported AS-Interface master profile		M4 (acc. to AS-Interface Specification V3.0)
Configuring the AS-Interface		Using pushbuttons on the front panel, with STEP 7 version V5.4 and higher, through web interface

Overview



PN	DP-M	DP-S	ASI-M
		■	■

DP/AS-Interface Link 20E connects PROFIBUS DP to AS-Interface. It performs the following functions:

- PROFIBUS DP slave and AS-Interface master
- Connection of up to 62 AS-Interface slaves and integrated analog value transmission (according to the extended AS-Interface Specification V3.0)
- Supports all AS-Interface master functions according to the extended AS-Interface specification V3.0, i. e. master profile M4
- Supply from AS-Interface cable; hence no additional power supply required
- Supports the uploading of the AS-Interface configuration in STEP 7 V5.2 and higher

Design

- Compact enclosure in degree of protection IP20 for standard rail mounting
- LEDs in the front panel for indicating the operating state and the readiness for operation of all connected and activated slaves
- Setting option for PROFIBUS DP address by pressing a button
- LED indication of the PROFIBUS DP slave address, DP bus faults and diagnostics
- Two pushbuttons for switching over the operating state and for adopting the existing ACTUAL configuration as the DESIRED configuration
- Power is supplied over the AS-Interface cable.

Function

DP/AS-Interface Link 20E enables a DP master to access all the slaves of an AS-Interface segment. According to the extended AS-Interface specification (V3.0) up to 62 slaves, each with 4 digital inputs and 4 digital outputs as well as analog slaves, can now be connected.

DP/AS-Interface Link 20E occupies as standard 32 bytes of input data and 32 bytes of output data in the DP master in which the I/O data of the connected AS-Interface slaves are stored. The size of the input/output buffer can be compressed so that only the required memory space of the DP master is occupied.

PROFIBUS DP masters are able in addition to initiate AS-Interface master calls to write parameters, change addresses, read diagnostic values through the acyclic PROFIBUS services.

Configuration

DP/AS-Interface Link 20E can be configured on PROFIBUS using STEP 7.

The manual comes in addition with the GSD files so that configuration is also possible on versions in which DP/AS-Interface Link 20E is not yet included as standard.

The configuration of the AS-Interface segment can be defined either by means of STEP 7 or simply by adopting the ACTUAL configuration. Commissioning is also possible without PROFIBUS.

With STEP 7 configuring the AS-Interface configuration can be uploaded in STEP 7 V5.2 and higher.

Technical specifications

AS-Interface bus cycle time	ms	5 with 31 slaves 10 with 62 slaves
PROFIBUS transmission rate	Mbit/s	Max. 12
Supported AS-Interface master profile		M4 (acc. to AS-Interface Specification V3.0)
Configuring the AS-Interface		Using pushbuttons on the front panel or with STEP 7 V5.1 SP2
Interfaces		
• AS-Interface connection		Screw terminals
• Connection to PROFIBUS		9-pole Sub D socket
Supply voltage		
• From AS-Interface cable		Acc. to AS-Interface Specification EN 50 295
Power consumption		
• From AS-Interface cable	mA	Max. 200
Load capacity		
5 V DC at PROFIBUS connection	mA	Max. 90
Power loss	W	4.5
Mounting		Standard mounting rail or direct mounting
Degree of protection		IP20
Permissible ambient conditions		
• Operating temperature		
- Horizontal mounting	°C	0 ... +60
- Vertical mounting	°C	0 ... +45
• Transport and storage temperature	°C	-40 ... +70
• Relative humidity	%	Max. 95 at +25 °C
Structural design		
• Module format		Similar to S7-200 module
• Dimensions (W x H x D)	mm	90 x 80 x 60
• Weight	g	About 200

AS-Interface

Slaves

I/O modules for operation in the field Introduction

Overview



K60



K20



K45

Three coordinated series of AS-Interface compact modules with digital and analog compact modules and a high degree of protection are available for operation in the field:

- Series K60 (digital and analog)
- Series K45 (digital)
- Series K20 (digital)

All compact modules are characterized by particularly simple handling. The K60 and K45 modules are mounted with a mounting plate. The mounting plate is used to receive the AS-Interface flat cables and enables mounting on a wall or standard mounting rail.

The K20 modules are directly mounted without a mounting plate and connected to the AS-Interface using a round cable.

Overview of digital compact modules

The following table provides an overview of the important features of the digital compact modules. For exact details, see the section "Technical specifications" in the chapter on the respective product.

Version	K60	K45	K20
8 inputs/2 outputs	✓	--	--
8 inputs	✓	--	--
4 inputs/4 outputs	✓	✓	✓
4 inputs/3 outputs	✓	--	--
4 inputs/2 outputs	✓	--	--
4 inputs	✓	✓	✓
2 inputs/2 outputs	--	✓	✓
4 outputs	✓	✓	✓
3 outputs	--	✓	--
AS-Interface connection	Flat cable/round cable	Flat cable	Round cable
I/O connection method	M12	M12/M8	M12/M8
Pin assignment	Standard/Y-II/Y	Standard/Y	Standard/Y
Degree of protection	IP65/IP67/IP68/IP69K	IP65/IP67	IP65/IP67
ATEX 3D (Zone 22)	✓	--	--
Extended address mode	✓	✓	✓

✓ Available

-- Not available

Function

The I/O modules have a large status display:

- With yellow LEDs for the switching state of the inputs and outputs
- With two LEDs or one dual LED (two-color LED) for AS-i communication (depending on the design)
- With one green LED for the auxiliary voltage U_{AUX}

The status of a module is indicated by LEDs using continuous or blinklight. This enables diagnostics at a glance. The following tables provide an overview of the LED status displays of the I/O modules.

LED status displays for K60 compact modules

AS-i	FAULT	Possible cause	Possible remedy
Green	Off	Normal operation; AS-Interface communication OK	--
Green	Red	No AS-i communication: <ul style="list-style-type: none"> • Master deactivated or offline • Slave not configured in master • Wrong slave type connected • Slave has wrong address 	Ensure AS-i communication: <ul style="list-style-type: none"> • Activate master or put it online • Reconfigure master • Connect correct module • Check slave address and correct if necessary
Green	Red flashing	Overload of sensor supply (slave is in RESET state and switches off completely)	Disconnect sensor cables from input sockets, install sensors with lower total current input, check sensors and cables
Green flashing	Red	Slave has address 0 (as-delivered state)	Address issued is not equal to 0
Green flashing (alternating flashing)	Red flashing	Overload of outputs (slave switches off all outputs)	Disconnect actuator cables from output sockets, check actuators and cables
Off	Off	No AS-i voltage, AS-i voltage with reversed polarity, AS-i voltage too low	Switch on AS-i voltage, connect correctly, measure AS-i voltage (approx. 30 V DC)

Note: The status "overload of outputs" (green flashing/red flashing, alternating) is not displayed by all modules.

Additional arrangement for K60 analog modules

AS-i	FAULT	Possible cause	Possible remedy
Green flashing (alternating flashing)	Red flashing	No analog data exchange (triple traffic) on AS-i AS-i master waits for analog output data from PLC (only for analog output modules) Overload of sensor supply (only for analog input modules)	Use AS-i master according to AS-i Spec. 2.1 or higher Set CPU to RUN, send data record with analog output data to AS-i master (CP 343-2, CP 343-2P, Link 20E) Disconnect sensor cables from input sockets, install sensors with lower total current input, check sensors and cables

LED status displays for K45 / K20 compact modules

AS-i/FAULT	Possible cause	Possible remedy
Green	Normal operation; AS-Interface communication OK	--
Red	No AS-i communication: <ul style="list-style-type: none"> • Master deactivated or offline • Slave not configured in master • Wrong slave type connected • Slave has wrong address 	Ensure AS-i communication: <ul style="list-style-type: none"> • Activate master or put it online • Reconfigure master • Connect correct module • Check slave address and correct if necessary
Red flashing	Overload of sensor supply (slave is in RESET state and switches off completely)	Disconnect sensor cables from input sockets, install sensors with lower total current input, check sensors and cables
Yellow-red flashing	Slave has address 0 (as-delivered state)	Address issued is not equal to 0
Green-red flashing	Overload of outputs (slave switches off all outputs)	Disconnect actuator cables from output sockets, check actuators and cables
Off	No AS-i voltage, AS-i voltage with reversed polarity, AS-i voltage too low	Switch on AS-i voltage, connect correctly, measure AS-i voltage (approx. 30 V DC)

Note: The status "overload of outputs" (green flashing/red flashing, alternating) is not displayed by all modules.

Additional LED status display for AUX POWER on modules with auxiliary voltage

AUX POWER	Possible cause	Possible remedy
Green	Normal operation; AS-Interface communication OK	--
Off	No auxiliary voltage Auxiliary voltage with reversed polarity Auxiliary voltage too low	Switch on 24 V DC auxiliary voltage, connect correctly, measure auxiliary voltage (approx. 24 V DC)

AS-Interface

Slaves

I/O modules for operation in the field Digital I/O modules, IP67 - K60

Overview

The K60 digital AS-Interface compact modules are characterized by optimized handling characteristics and user-friendliness. They permit the mounting times and start-up times of AS-Interface to be reduced by up to 40 %.

Assembly of the K60 modules is performed with a mounting plate which accommodates the AS-Interface shaped cables. Two different mounting plates are offered for:

- Wall mounting
- Standard rail mounting

Addressing of the K60 modules is performed using an addressing socket integrated in the compact module. The addresses can also be assigned after installed.

K60 compact modules with a maximum of four digital inputs and outputs

These compact modules contain the communication electronics and the M12 standard connections for inputs and outputs. Using M12 standard connectors, a maximum of four sensors and four actuators can be simply and reliably connected to the compact module.

The mounting plate and the compact module are joined together by means of a screw, with simultaneous contacting of the AS-Interface cable by the service-proven insulation piercing method.

K60 compact modules with a maximum of eight digital inputs

These modules have eight digital inputs for connection through M12 plugs.

The module requires two AS-Interface addresses for processing all eight inputs. As with every compact module, the addressing can be performed through a double addressing socket.

K60 compact modules with a four digital inputs and outputs according to AS-Interface specification 3.0

The new AS-i specification 3.0 adds a number of completely new features to the AS-Interface bus system. The extended address mode (A/B addresses) enables the connection of up to 62 slaves on one AS-i network. With the extended address mode according to specification 3.0, four outputs are now possible even with A/B slaves (instead of only three outputs possible up to now with specification 2.1). Hence with full expansion of an AS-i network, there are now 248 inputs as well as 248 outputs available on one AS-i system. Modules with four inputs and four outputs as A/B slaves according to specification 3.0 are also available as K60 compact modules.

Please note that these modules can be used only with a new master according to AS-i specification 3.0 (e. g. the new DP/AS-i LINK Advanced or IE/AS-i LINK PN IO) and that the cycle times for the outputs can extend to max. 20 ms.

K60 data couplers

An AS-Interface data coupler has been added to the K60 compact module range. Integrated in this module are two AS-Interface slaves which are connected to two different AS-i networks. Each of the two integrated slaves has four virtual inputs and four virtual outputs. The bidirectional data transmission of 4 data bits between two AS-i networks is thus possible in a simple and cost-effective manner. The data coupler needs its own address in each AS-i network.

Each AS-i network works with a different cycle time depending on the number of stations. Hence two AS-i networks are not necessarily synchronous. For this reason the AS-i data coupler can be used to transmit only standard data and no safe data.

K60 compact modules for use in hazardous areas (ATEX)

Two versions of the K60 modules are available for operation in Zone 22 hazardous areas according to Classification II 3D (dusty atmosphere, non-conductive dust). The version with four inputs and four outputs has the designation (Ex) II 3D T75°C IP65X and the version with four inputs has the designation (Ex) II 3D T60 °C IP65X.

Special conditions have to be observed for the safe operation of these devices. In particular the module must be protected by suitable protective measures from mechanical damage. Other conditions for safe operation, see section [Technical specifications](#).

Design

K60 compact module



The compact modules are mounted on mounting plates in just two moves:

- Insert the AS-Interface flat cables in the mounting plate
- Hook in the module and fix it with a screw

Contacting with the AS-Interface cable is performed by the insulation displacement terminals integrated in the module when screwed on.

Addressing is performed using an integrated addressing socket. The M12 sockets which are not required must be closed with 3RK1 901-1KA00 sealing caps in order to guarantee the quoted degree of protection. The compact module with eight digital inputs requires two AS-Interface addresses. Addressing is performed using a double addressing socket integrated in the module.

K60 mounting plates

The K60 mounting plate serves as a fixture for digital and analog K60 compact modules. It has cable fixtures for the yellow and black AS-Interface flat cable.

If both the yellow and black AS-Interface cables are to be routed completely through the module, no additional seals are required.

Additional seals are required only if one or both cables are to be terminated in the module. In this case additional seals (straight and shaped) have to be inserted in the mounting plate. These seals are not included in the scope of supply and must be ordered separately (3RK1 902-0AR00).

Technical specifications

Technical specifications common to all digital I/O modules IP67 – K60

Operational voltage acc. to AS-Interface specification	V	26.5 ... 31.6
Input circuit		PNP
Inputs		
• Sensors		2- and 3-conductors
• Switching level High	V	≥ 10
• Input current Low/High	mA	≤ 1.5/≥ 6
Outputs		
• Type of output		Solid-state
• Short-circuit protection		Built-in
• Induction protection		Built-in
• External power supply 24 V DC		Using black AS-Interface flat cable
• Watchdog		Built-in
AS-Interface certificate		Yes (or requested for in case of new units)
Approvals		UL, CSA, shipbuilding (or requested for in case of new units)
Degree of protection		IP67
Ground terminal		Pin 5 of each M12 socket is connected to the grounding wrist strap in the mounting plate using a pin
Ambient temperature	°C	-25 ... +85
Storage temperature	°C	-40 ... +85
Status displays		
• Display of I/Os		Yellow LED
• Display of U_{aux}		Green LED
• Display of AS-Interface/diagnostics		Green/red LED
Mounting		Using mounting plate for K60 compact module

Note:

All K60 compact modules are delivered with high-grade steel screws/sockets.

An external additional supply (AUX POWER) of 20 to 30 V DC is required for the supply of the output circuits. The additional supply must comply with VDE 0106 (PELV), safety class III.

AS-Interface

Slaves

I/O modules for operation in the field
Digital I/O modules, IP67 - K60

		8 inputs/2 outputs 2 ampere	8 inputs --	8 inputs --	8 inputs --
		A/B slave Special assignment 3RK2 400-1HQ00-0AA3	Standard slave Y-II assignment 3RK1 200-0DQ00-0AA3	A/B slave Y-II assignment 3RK2 200-0DQ00-0AA3	A/B slave Y-II assignment 3RK2 200-1DQ00-1AA3
Total current input	mA	≤ 300	≤ 270	≤ 270	≤ 45
Short-circuit and overload resistant sensor supply		Yes	Yes	Yes	Yes
Sensor power supply		Using AS-Interface	Using AS-Interface	Using AS-Interface	Using U_{aux}
Current carrying capacity for all inputs ($T_u \leq 40^\circ\text{C}$)	mA	200	200	200	2000
Socket assignment of inputs		Pin 1: Sensor supply L+ Pin 2: Data input II Pin 3: Sensor supply L- Pin 4: Data input I Pin 5: Ground terminal	Pin 1: Sensor supply L+ Pin 2: Data input II Pin 3: Sensor supply L- Pin 4: Data input I Pin 5: Ground terminal	Pin 1: Sensor supply L+ Pin 2: Data input II Pin 3: Sensor supply L- Pin 4: Data input I Pin 5: Ground terminal	Pin 1: Sensor supply L+ Pin 2: Data input II Pin 3: Sensor supply L- Pin 4: Data input I Pin 5: Ground terminal
Outputs					
• Current carrying capacity per output DC 12/13 typical	A	2	--	--	--
• Maximum summation current per module	A	4	--	--	--
• Socket assignment of outputs		Pin 3: "-" Pin 4: Output Pin 5: Ground terminal	--	--	--
Slave type		A/B slave	Standard slave	A/B slave	A/B slave
I/O configuration		0 (addr. 1)/7 (addr. 2)	0	0	0
ID/ID2 code		I/O (addr. 1 and 2)	1/F	I/O	I/O
Assignment of data bits					
• Socket 1		Pin 4: IN1 (D0) (addr. 1) Pin 2: IN2 (D1) (addr. 1)	Pin 4: IN1 (D0) (addr. 1) Pin 2: IN2 (D1) (addr. 1)	Pin 4: IN1 (D0) (addr. 1) Pin 2: IN2 (D1) (addr. 1)	Pin 4: IN1 (D0) (addr. 1) Pin 2: IN2 (D1) (addr. 1)
• Socket 2		Pin 4: IN2 (D1) (addr. 1)	Pin 4: IN2 (D1) (addr. 1)	Pin 4: IN2 (D1) (addr. 1)	Pin 4: IN2 (D1) (addr. 1)
• Socket 3		Pin 4: IN3 (D2) (addr. 1) Pin 2: IN4 (D3) (addr. 1)	Pin 4: IN3 (D2) (addr. 1) Pin 2: IN4 (D3) (addr. 1)	Pin 4: IN3 (D2) (addr. 1) Pin 2: IN4 (D3) (addr. 1)	Pin 4: IN3 (D2) (addr. 1) Pin 2: IN4 (D3) (addr. 1)
• Socket 4		Pin 4: IN4 (D3) (addr. 1)	Pin 4: IN4 (D3) (addr. 1)	Pin 4: IN4 (D3) (addr. 1)	Pin 4: IN4 (D3) (addr. 1)
• Socket 5		Pin 4: IN1 (D0) (addr. 2) Pin 2: IN2 (D1) (addr. 2)	Pin 4: IN1 (D0) (addr. 2) Pin 2: IN2 (D1) (addr. 2)	Pin 4: IN1 (D0) (addr. 2) Pin 2: IN2 (D1) (addr. 2)	Pin 4: IN1 (D0) (addr. 2) Pin 2: IN2 (D1) (addr. 2)
• Socket 6		Pin 4: IN2 (D1) (addr. 2)	Pin 4: IN2 (D1) (addr. 2)	Pin 4: IN2 (D1) (addr. 2)	Pin 4: IN2 (D1) (addr. 2)
• Socket 7		Pin 4: OUT1 (D0) (addr. 2) Pin 2: IN3 (D2) (addr. 2)	Pin 4: IN3 (D2) (addr. 2) Pin 2: IN4 (D3) (addr. 2)	Pin 4: IN3 (D2) (addr. 2) Pin 2: IN4 (D3) (addr. 2)	Pin 4: IN3 (D2) (addr. 2) Pin 2: IN4 (D3) (addr. 2)
• Socket 8		Pin 4: OUT2 (D1) (addr. 2) Pin 2: IN4 (D3) (addr. 2)	Pin 4: IN4 (D3) (addr. 2)	Pin 4: IN4 (D3) (addr. 2)	Pin 4: IN4 (D3) (addr. 2)
Number of I/O sockets		8	8	8	8
Special features for the addressing		Module requires two addresses	Module requires two addresses	Module requires two addresses	Module requires two addresses

		4 inputs/4 outputs		
		2 ampere	2 ampere	1 ampere
		Standard slave Y-II assignment 3RK1 400-1DQ00-0AA3	Standard slave Standard assignment 3RK1 400-1CQ00-0AA3	Standard slave Y-II assignment 3RK1 400-1DQ01-0AA3
Total current input	mA	≤ 270	≤ 270	≤ 270
Short-circuit and overload resistant sensor supply		Yes	Yes	Yes
Sensor power supply		Using AS-Interface	Using AS-Interface	Using AS-Interface
Current carrying capacity for all inputs (T_U ≤ 40 °C)	mA	200	200	200
Socket assignment of inputs		Pin 1: Sensor supply L+ Pin 2: Data input II Pin 3: Sensor supply L- Pin 4: Data input I Pin 5: Ground terminal	Pin 1: Sensor supply L+ Pin 2: Data input I Pin 3: Sensor supply L- Pin 4: Data input I Pin 5: Ground terminal	Pin 1: Sensor supply L+ Pin 2: Data input II Pin 3: Sensor supply L- Pin 4: Data input I Pin 5: Ground terminal
Outputs				
• Current carrying capacity per output DC 12/13 typical	A	2	2	1
• Maximum summation current per module	A	4	4	4
• Socket assignment of outputs		Pin 3: "-" Pin 2/4: Output Pin 5: Ground terminal	Pin 3: "-" Pin 4: Output Pin 5: Ground terminal	Pin 3: "-" Pin 2/4: Output Pin 5: Ground terminal
Slave type		Standard slave	Standard slave	Standard slave
I/O configuration		7	7	7
ID/ID2 code		F/F	0/F	F/F
Assignment of data bits				
• Socket 1		Pin 4: IN1 (D0) Pin 2: IN2 (D1)	Pin 2/4: IN1 (D0)	Pin 4: IN1 (D0) Pin 2: IN2 (D1)
• Socket 2		Pin 4: IN2 (D1)	Pin 2/4: IN2 (D1)	Pin 4: IN2 (D1)
• Socket 3		Pin 4: IN3 (D2) Pin 2: IN4 (D3)	Pin 2/4: IN3 (D2)	Pin 4: IN3 (D2) Pin 2: IN4 (D3)
• Socket 4		Pin 4: IN4 (D3)	Pin 2/4: IN4 (D3)	Pin 4: IN4 (D3)
• Socket 5		Pin 4: OUT1 (D0) Pin 2: OUT2 (D1)	Pin 4: OUT1 (D0)	Pin 4: OUT1 (D0) Pin 2: OUT2 (D1)
• Socket 6		Pin 4: OUT2 (D1)	Pin 4: OUT2 (D1)	Pin 4: OUT2 (D1)
• Socket 7		Pin 4: OUT3 (D2) Pin 2: OUT4 (D3)	Pin 4: OUT3 (D2)	Pin 4: OUT3 (D2) Pin 2: OUT4 (D3)
• Socket 8		Pin 4: OUT4 (D3)	Pin 4: OUT4 (D3)	Pin 4: OUT4 (D3)
Number of I/O sockets		8	8	8

AS-Interface

Slaves

I/O modules for operation in the field
Digital I/O modules, IP67 - K60

	4 inputs/4 outputs 1 ampere Standard slave Standard assignment 3RK1 400-1DQ03-0AA3	4 inputs/4 outputs 2 ampere A/B slave (Spec. 3.0) Y-II assignment 3RK2 400-1DQ00-0AA3	4 inputs/4 outputs 2 ampere A/B slave (Spec. 3.0) Y-II assignment 3RK2 400-1DQ00-1AA3	4 inputs/3 outputs 2 ampere A/B slave Y-II assignment 3RK2 400-1FQ03-0AA3	4 inputs/2 outputs 2 ampere Standard slave Y-II assignment 3RK1 400-1MQ00-0AA3
Total current input	mA ≤ 270	≤ 270	≤ 60	≤ 270	≤ 270
Short-circuit and overload resistant sensor supply	Yes	Yes	Yes	Yes	Yes
Sensor power supply	Using AS-Interface	Using AS-Interface	Using U_{aux}	Using AS-Interface	Using AS-Interface
Current carrying capacity for all inputs ($T_u \leq 40^\circ\text{C}$)	mA 200	200	1000	200	200
Socket assignment of inputs	Pin 1: Sensor supply L+ Pin 2: Data input II Pin 3: Sensor supply L- Pin 4: Data input I Pin 5: Ground terminal				
Outputs					
• Current carrying capacity A per output DC 12/13 typical	1	2	2	2	2
• Maximum summation current per module	A 4	4	4	4	4
• Socket assignment of outputs	Pin 3: "-" Pin 2/4: Output Pin 5: Ground terminal				
Slave type	Standard slave	A/B slave (Spec. 3.0)	A/B slave (Spec. 3.0)	A/B slave	Standard slave
I/O configuration	7	7	7	7	7
ID/ID2 code	0/F	A/7	A/7	A/2	F/F
Assignment of data bits					
• Socket 1	Pin 2/4: IN1 (D0)	Pin 4: IN1 (D0) Pin 2: IN2 (D1)	Pin 4: IN1 (D0) Pin 2: IN2 (D1)	Pin 4: IN1 (D0) Pin 2: IN2 (D1)	Pin 4: IN1 (D0) Pin 2: IN2 (D1)
• Socket 2	Pin 2/4: IN2 (D1)	Pin 4: IN2 (D1)	Pin 4: IN2 (D1)	Pin 4: IN2 (D1)	Pin 4: IN2 (D1)
• Socket 3	Pin 2/4: IN3 (D2)	Pin 4: IN3 (D2) Pin 2: IN4 (D3)	Pin 4: IN3 (D2) Pin 2: IN4 (D3)	Pin 4: IN3 (D2) Pin 2: IN4 (D3)	Pin 4: IN3 (D2) Pin 2: IN4 (D3)
• Socket 4	Pin 2/4: IN4 (D3)	Pin 4: IN4 (D3)	Pin 4: IN4 (D3)	Pin 4: IN4 (D3)	Pin 4: IN4 (D3)
• Socket 5	Pin 4: OUT1 (D0)	Pin 4: OUT1 (D0) Pin 2: OUT2 (D1)	Pin 4: OUT1 (D0) Pin 2: OUT2 (D1)	Pin 4: OUT1 (D0) Pin 2: OUT2 (D1)	Pin 4: OUT1 (D0) Pin 2: OUT2 (D1)
• Socket 6	Pin 4: OUT2 (D1)	Pin 4: OUT2 (D1)	Pin 4: OUT2 (D1)	Pin 4: OUT2 (D1)	Pin 4: OUT2 (D1)
• Socket 7	Pin 4: OUT3 (D2)	Pin 4: OUT3 (D2) Pin 2: OUT4 (D3)	Pin 4: OUT3 (D2) Pin 2: OUT4 (D3)	Pin 4: OUT3 (D2)	Not assigned (closed)
• Socket 8	Pin 4: OUT4 (D3)	Pin 4: OUT4 (D3)	Pin 4: OUT4 (D3)	Not assigned (closed)	Not assigned (closed)
Number of I/O sockets	8	8	8	7	6
Special master requirements		A master acc. to AS-Interface Specification 3.0 is required for this module	A master acc. to AS-Interface Specification 3.0 is required for this module		

	4 inputs	2 x 2 inputs/ 2 x 2 outputs	4 outputs	Data coupler 4 inputs/4 outputs
	-- Standard slave Y-II assignment 3RK1 200-0CQ00-0AA3	1 ampere Standard slave Y-II assignment 3RK1 400-1DQ02-0AA3	2 ampere Standard slave Y-II assignment 3RK1 100-1CQ00-0AA3	-- Standard slave -- 3RK1 408-8SQ00-0AA3
Total current input	mA ≤ 270	≤ 270	≤ 270	≤ 70
Short-circuit and overload resistant sensor supply	Yes	Yes	Yes	--
Sensor power supply	Using AS-Interface	Using AS-Interface	Using AS-Interface	--
Current carrying capacity for all inputs (T_u ≤ 40 °C)	mA 200	200	--	--
Socket assignment of inputs	Pin 1: Sensor supply L+ Pin 2: Data input II Pin 3: Sensor supply L- Pin 4: Data input I Pin 5: Ground terminal	Pin 1: Sensor supply L+ Pin 2: Data input II Pin 3: Sensor supply L- Pin 4: Data input I Pin 5: Ground terminal	--	--
Outputs				
• Current carrying capacity per output DC 12/13 typical	A --	1	2	--
• Maximum summation current per module	A --	4	4	--
• Socket assignment of outputs	--	Pin 3: "--" Pin 2/4: Output Pin 5: Ground terminal	Pin 3: "--" Pin 2/4: Output Pin 5: Ground terminal	--
Slave type	Standard slave	Standard slave	Standard slave	Standard slave
I/O configuration	0	7	8	7
ID/ID2 code	1/F	F/F	1/F	F/F
Assignment of data bits				
• Socket 1	Pin 4: IN1 (D0) Pin 2: IN2 (D1)	Pin 4: IN1 (D0) Pin 2: IN2 (D1)	--	D0out AS-i 1 = D0in AS-i 2
• Socket 2	Pin 4: IN2 (D1)	Not assigned (closed)	--	D0out AS-i 2 = D0in AS-i 1
• Socket 3	Pin 4: IN3 (D2) Pin 2: IN4 (D3)	Pin 4: IN3 (D2) Pin 2: IN4 (D3)	--	D1out AS-i 1 = D1in AS-i 2
• Socket 4	Pin 4: IN4 (D3)	Not assigned (closed)	--	D1out AS-i 2 = D1in AS-i 1
• Socket 5	Not assigned (closed)	Pin 4: OUT1 (D0) Pin 2: OUT2 (D1)	Pin 4: OUT1 (D0) Pin 2: OUT2 (D1)	D2out AS-i 1 = D2in AS-i 2
• Socket 6	Not assigned (closed)	Not assigned (closed)	Pin 4: OUT2 (D1)	D2out AS-i 2 = D2in AS-i 1
• Socket 7	Not assigned (closed)	Pin 4: OUT3 (D2) Pin 2: OUT4 (D3)	Pin 4: OUT3 (D2) Pin 2: OUT4 (D3)	D3out AS-i 1 = D3in AS-i 2
• Socket 8	Not assigned (closed)	Not assigned (closed)	Pin 4: OUT4 (D3)	D3out AS-i 2 = D3in AS-i 1
Number of I/O sockets	4	4	4	0
Special features for the addressing	--	--	--	Module requires two addresses

AS-Interface

Slaves

I/O modules for operation in the field
Digital I/O modules, IP67 - K60

	4 inputs/4 outputs	4 inputs
	Version ATEX (Ex) II 3D X 2 ampere Standard slave Y-II assignment 3RK1 400-1DQ05-0AA3	Version ATEX (Ex) II 3D X -- Standard slave Y-II assignment 3RK1 200-0CQ05-0AA3
Total current input	mA ≤ 270	≤ 270
Short-circuit and overload resistant sensor supply	Yes	Yes
Sensor power supply	Using AS-Interface	Using AS-Interface
Current carrying capacity for all inputs ($T_u \leq 40^\circ\text{C}$)	mA 200	200
Socket assignment of inputs	Pin 1: Sensor supply L+ Pin 2: Data input II Pin 3: Sensor supply L- Pin 4: Data input I Pin 5: Ground terminal	Pin 1: Sensor supply L+ Pin 2: Data input II Pin 3: Sensor supply L- Pin 4: Data input I Pin 5: Ground terminal
Outputs		
• Current carrying capacity per output DC 12/13 typical	A 2	--
• Maximum summation current per module	A 4	--
• Socket assignment of outputs	Pin 3: „-“ Pin 2/4: Output Pin 5: Ground terminal	--
Slave type	Standard slave	Standard slave
I/O configuration	7	0
ID/ID2 code	F/F	1/F
Assignment of data bits		
• Socket 1	Pin 4: IN1 (D0) Pin 2: IN2 (D1)	Pin 4: IN1 (D0) Pin 2: IN2 (D1)
• Socket 2	Pin 4: IN2 (D1)	Pin 4: IN2 (D1)
• Socket 3	Pin 4: IN3 (D2) Pin 2: IN4 (D3)	Pin 4: IN3 (D2) Pin 2: IN4 (D3)
• Socket 4	Pin 4: IN4 (D3)	Pin 4: IN4 (D3)
• Socket 5	Pin 4: OUT1 (D0) Pin 2: OUT2 (D1)	Not assigned (closed)
• Socket 6	Pin 4: OUT2 (D1)	Not assigned (closed)
• Socket 7	Pin 4: OUT3 (D2) Pin 2: OUT4 (D3)	Not assigned (closed)
• Socket 8	Pin 4: OUT4 (D3)	Not assigned (closed)
Number of I/O sockets	8	4
Prescribed use	Use in Zone 22 hazardous areas according to Classification II 3D (dusty atmosphere, non-conductive dust), resistance to shock: 1 joule Conformance with Directive 94/9/EC (ATEX) is verified through compliance with the standards EN 50281-1-1 and EN 60947-5-2	
Designations	(Ex) II 3D T75°C IP65X	(Ex) II 3D T60°C IP65X
Limiting conditions for safe operation	<ul style="list-style-type: none"> • Suitable protective measures must be taken to protect the module from mechanical damage. • All M12 plug-in connectors must be secured by a lock-clip against unauthorized opening such that the connector cannot be disconnected by hand but only by destroying the lock-clip. A suitable lock-clip is available from Franz Binder GmbH + Co. elektrische Bauelemente KG, Rötelsstrasse 27, 74172 Neckarsulm, Germany Tel. +49 (0) 7132/325-0, Fax +49 (0) 7132/325-150, http://www.binder-connector.com, Article No. 16-0977-000 • All the M12 sockets which are not assigned must be closed with 3RK1 901-1KA01 sealing caps (tamper-proof version) such that they cannot be released by hand. • Addressing the module using the 3RK1 904-2AB01 addressing unit is only permitted outside the Ex-Zone 22. • When the addressing operation is finished, the addressing socket must be closed with a 3RK1 901-1KA01 sealing cap (tamper-proof version) such that it cannot be released by hand. • If an additional supply (AUX POWER) is required, it must comply with VDE 0106 (PELV), safety class III. 	
Installation and commissioning	<ul style="list-style-type: none"> • The devices are approved for an ambient temperature of -25 to +85 °C. • The devices must be configured, connected and commissioned by qualified, responsible personnel only. An incorrect response may cause serious injury to persons and damage to property. • It is assumed that personnel are familiar with the assignment of classes to the permitted hazardous zones. • The plug-in connectors and AS-Interface cables must not be connected or disconnected when live. • The units require no maintenance. • No modifications or repairs are allowed to be carried out on the units. • All the above points must be observed in the event of replacement. • See also Regulations for Installation EN 60079-14 / EN 50281-1-2. 	

		K60 mounting plates	
		For wall mounting	For standard rail mounting
		3RK1 901-0CA00	3RK1 901-0CB01
Ambient temperature	°C	-40 ... +85	-40 ... +85
Degree of protection		IP67 with screw-mounted K60 compact module	IP67 with screw-mounted K60 compact module
Connection methods		For shaped AS-Interface cable, contacting using insulation displacement terminals integrated in the compact module	For shaped AS-Interface cable, contacting using insulation displacement terminals integrated in the compact module
Mounting		<ul style="list-style-type: none"> • Wall mounting • On profile system (corresponding sliding blocks required) • Hole spacing compatible with K45 mounting plate for wall mounting 	<ul style="list-style-type: none"> • Standard rail mounting • For the previous 3RK1 901-0CB00 version of the standard rail mounting it is also possible to order the standard mounting rail adapter separately as a spare part: 3RX1 660-0B. This adapter is not required for the new 3RK1 901-0CB01 version.
Additional seals		Additional seals are required only when the flat cables end in the module (3RK1 902-0AR00).	Additional seals are required only when the flat cables end in the module (3RK1 902-0AR00).

Dimensional drawings

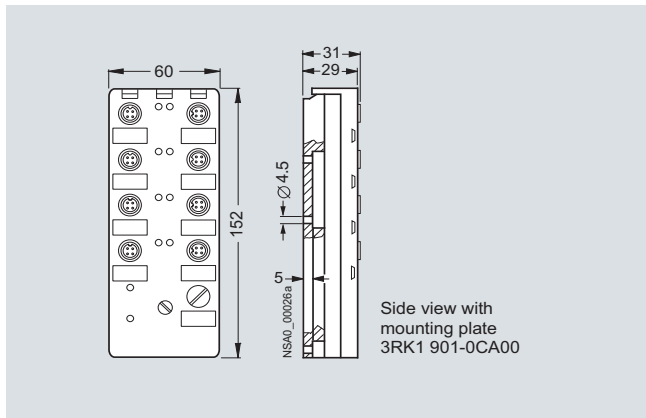

I/O module

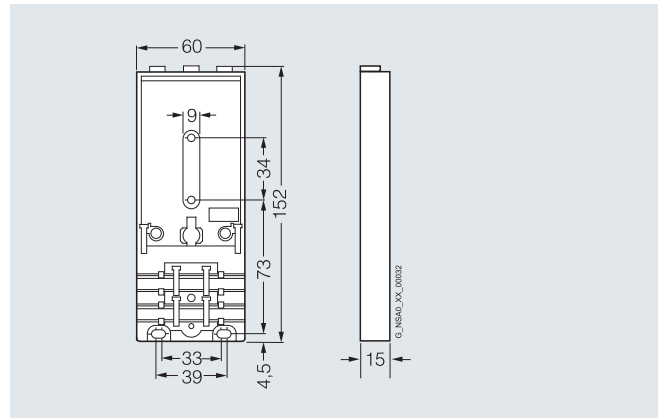

3RK1 901-0CB01 mounting plate for standard rail mounting

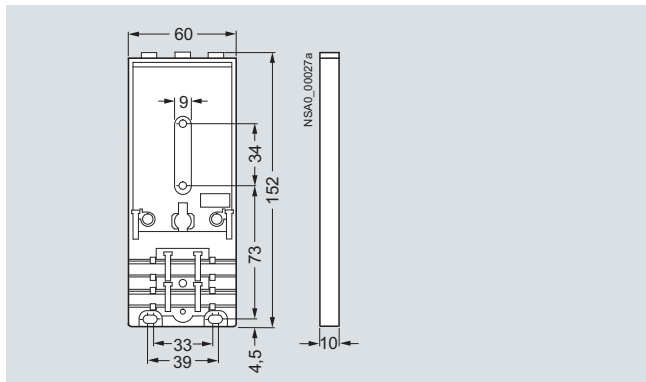

3RK1 901-0CA00 mounting plate for wall mounting

AS-Interface

Slaves

I/O modules for operation in the field
Digital I/O modules, IP67 - K60

Schematics

Terminal assignment for input (M12 socket)

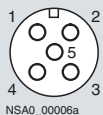

Pin 1: Supply L+
Pin 2: Input signal (bridged with Pin 4)
Pin 3: Supply L-
Pin 4: Input signal (bridged with Pin 2)
Pin 5: Ground terminal

NSAO_00006a

Standard assignment

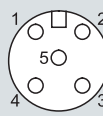

Pin 1: Supply L+
Pin 2: Input signal 2
Pin 3: Supply L-
Pin 4: Input signal 1
Pin 5: Not assigned

NSAO_00008

Y assignment

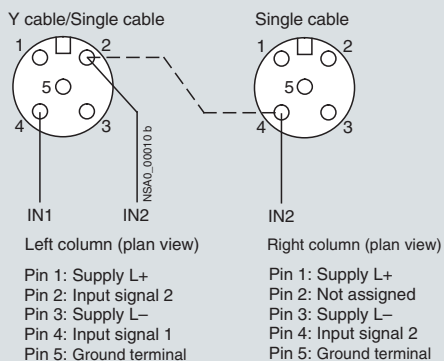

Y-II assignment

Terminal assignment for output (M12 socket)

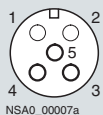

Pin 1: Not assigned
Pin 2: Not assigned
Pin 3: Supply L-
Pin 4: Output signal
Pin 5: Ground terminal

NSAO_00007a

Standard assignment

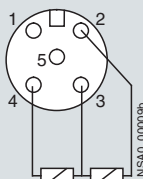

Pin 1: Not assigned
Pin 2: Output signal 2
Pin 3: Supply L-
Pin 4: Output signal 1
Pin 5: Not assigned

NSAO_00009b

Y assignment

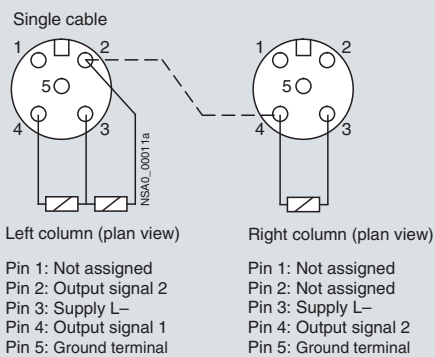

Y-II assignment

Overview

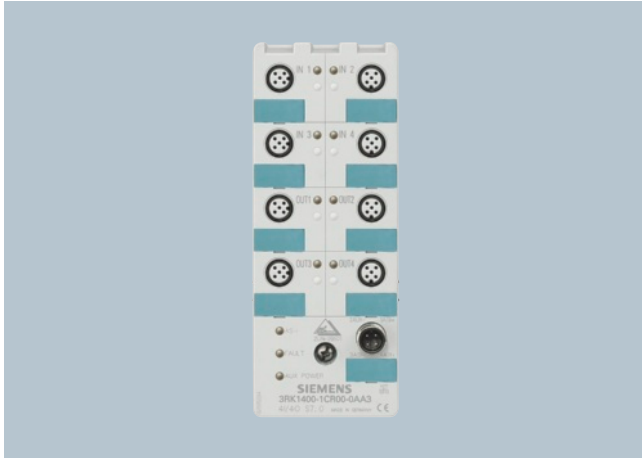

Modules with degree of protection IP67 cannot be used in areas exposed to permanently high levels of humidity, in applications with drilling emulsions and cutting oils or when cleaning with high-pressure cleaners. The answer for these applications is provided by the expansion of the K60 compact modules with the K60R module with degree of protection IP68/IP69K.

The K60R modules are connected instead of the AS-Interface flat cable using a round cable with M12 cable box. The AS-Interface bus cable and the 24 V DC auxiliary voltage supply are routed in this case in a shared round cable.

Degree of protection IP68 permits many new applications, which were impossible with the former field modules with degree of protection IP67. In applications such as filling plants or machine-tools the K60R with degree of protection IP68 enables the module to be used directly in zones exposed to permanent loading by humidity. It is thus possible to make even more rigorous savings in wiring with AS-Interface. For IP68 test conditions, see [section Tests IP68/IP69K](#).

Cleaning with high-pressure cleaners, such as is regularly performed in the food drinks industry for instance, is possible without difficulty (IP69K).

In applications with tow chains, many users rely on placing the AS-Interface bus cable in a round cable. With the K60R module there is a round cable connection for direct connection to a round cable. No adapter is required.

Mounting

The same mounting plates are used as for the K60 modules. Instead of using flat cables the K60R is connected using a 4-pole round cable with an M12 connection. With the K60R the mounting plate thus serves only as a fixture and ground terminal.

Addressing

Addressing is performed using the same socket as for the bus connection. Connecting the module to the 3RK1 904-2AB01 addressing unit is performed using a standard M12 cable (e. g. 3RX8 000-0GF32-1AB5). If the older version of the 3RK1 904-2AB00 addressing unit is used, a special addressing cable (3RK1 901-3RA00) is required. When the mounting is finished, the module is connected with the addressing cable to the addressing unit and addressed. The addressing cable is then removed and the module connected to the bus cable.

Connection

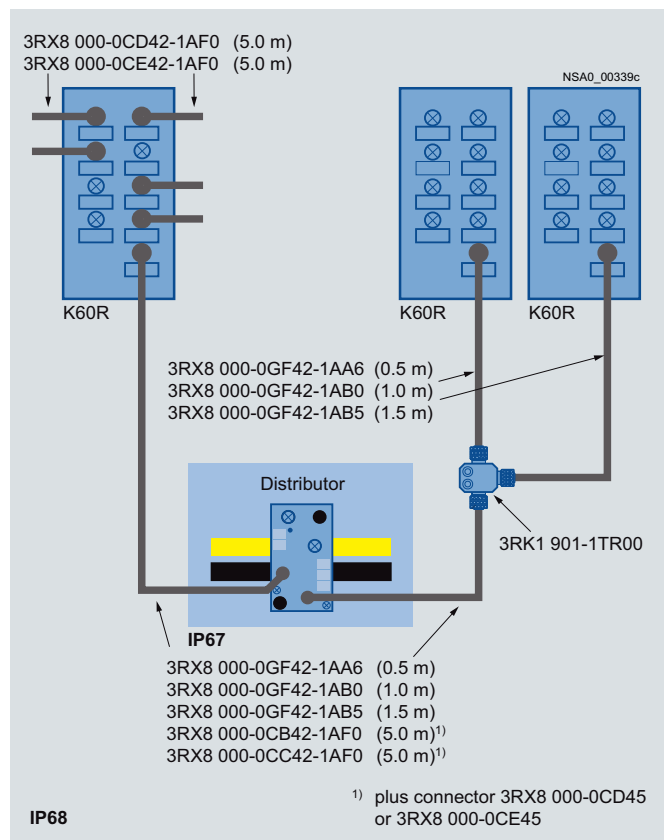

K60R connection options

In the IP67 environment the service-proven standard components are connected using flat cables. Spur lines are laid into the IP68 environment by means of an AS-Interface M12 feeder (3RK1 901-1NR..). The module is connected with a round cable to an M12 cable box. For this purpose the module has an M12 bus connection instead of the former addressing socket. The AS-Interface bus cable and the 24 V DC auxiliary power supply are routed together in a 4-pole round cable. There must be no ground conductor in this round cable. Connection to ground is made through the mounting plate.

In the IP68 environment only cables with extruded M12 plugs may be used. These cables are available preassembled as an M12 cable plug/cable box version:

- 3RX8 000-0GF42-1AA6: 0.5 m long
- 3RX8 000-0GF42-1AB0: 1.0 m long
- 3RX8 000-0GF42-1AB5: 1.5 m long

To connect the distributor and the K60R module over long distances it is also possible to use freely configurable cables with an M12 cable box and an open cable end, which are fitted with an M12 plug (straight version: 3RX8 000-0CD45, 3RX8 000-0CE45 angle plug) and connected to the distributor. This cable is available in two versions:

- 3RX8 000-0CB42-1AF0: 5 m long, with M12 cable box
- 3RX8 000-0CC42-1AF0: 5 m long, with M12 angle cable box

To connect more than one K60R module to one spur line, the spur line can be split again using a T distributor (3RK1 901-1TR00) with degree of protection IP68.

AS-Interface

Slaves

I/O modules for operation in the field Digital I/O modules, IP68/IP69K - K60R

Please note the following boundary conditions:

- The configuration guidelines for AS-Interface apply. For all M12 connecting cables the maximum permissible current is limited to 4 A. The cross-section of these cables amounts to just 0.34 mm². For connection of the K60R modules, the aforementioned M12 connecting cables can be used for the spur lines. The voltage drop caused by the ohmic resistance (approx. 0.11 Ω/m) must be taken into account.
- For round cable connections with shared AS-i and U_{aux} in a single cable, the following maximum lengths apply:
 - Per spur line from feeder to module: maximum 5 m
 - Total of all round cable segments in an AS-Interface network: maximum 20 m

Tests IP68/IP69K

K60R modules were tested with the following tests:

- Stricter test than IP67:
min 90 m in 1.8 m depth of water (IP67: 30 min at 1 m depth of water)
- Salt water test:
Five months in salt water, 20 cm deep, at room temperature
- Test with particularly creepable oil:
Five months completely under oil at room temperature
- Test with drilling emulsion:
Five months at room temperature (components of the drilling emulsion: Anionic and non-ionic emulsifiers, paraffinic low-aromatic mineral oil, boric acid alkanolamines, corrosion inhibitors, oil content 40 %)
- Test in oil bath (Excelence 416 oil) with alternating oil bath temperature:
130 cycles of 15 to 55 °C, two months
- Cleaning with a high-pressure cleaner according to IP69K:
80 to 100 bar, 10 to 15 cm distance, time per side > 30 sec, water temperature 80 °C

To simulate requirements as realistically as possible the modules were artificially aged prior to the tests by 15 temperature cycles of -25/+85 °C. During the test the modules were connected to 3RX1 connecting cables. Unassigned connections were closed with 3RK1 901-1KA00 sealing caps.

Note:

Sealing caps and M12 connections must be tightened with the correct torque.

Technical specifications

		4 inputs/4 outputs IP68/IP69K
		Standard assignment 3RK1 400-1CR00-0AA3
Operational voltage acc. to AS-Interface specification	V	26.5 ... 31.6
Total current input	mA	≤ 270
Input circuit		PNP
Inputs		
• Sensor supply using AS-Interface		Short-circuit and overload resistant
• Sensors		2- and 3-conductors
• Voltage range	V	20 ... 30
• Current carrying capacity for all inputs ($T_u \leq 40$ °C)	mA	200
• Switching level High	V	≥ 10
• Input current Low/High	mA	≤ 1.5/≥ 6
• Socket assignment of inputs		Pin 1: Sensor supply L+ Pin 2: Data input I Pin 3: Sensor supply L- Pin 4: Data input I Pin 5: Ground terminal
Outputs		
• Type of output		Solid-state
• Current carrying capacity per output DC 12/13 typical	A	2
• Maximum summation current per module	A	4
• Socket assignment of outputs		Pin 3: "-" Pin 4: Output Pin 5: Ground terminal
• Short-circuit protection		Built-in
• Induction protection		Built-in
• External power supply 24 V DC		Shared round cable connection with AS-Interface connection through M12 female connector
• Watchdog		Built-in
Slave type		Standard slave
I/O configuration		7
ID/ID2 code		0/F

4 inputs/4 outputs IP68/IP69K	
Standard assignment 3RK1 400-1CR00-0AA3	
Assignment of data bits	
• Socket 1	Pin 2/4: IN1 (D0)
• Socket 2	Pin 2/4: IN2 (D1)
• Socket 3	Pin 2/4: IN3 (D2)
• Socket 4	Pin 2/4: IN4 (D3)
• Socket 5	Pin 4: OUT1 (D0)
• Socket 6	Pin 4: OUT2 (D1)
• Socket 7	Pin 4: OUT3 (D2)
• Socket 8	Pin 4: OUT4 (D3)
AS-Interface certificate	Yes
Degree of protection	IP68/IP69K with 3RK1 901-0CA00 IP68 mounting plate test conditions see section "Overview" --> "Tests IP68/IP69K" The degree of protection is achieved only when all M12 connections are tightened with the correct torque. The I/O sockets which are not required must be closed with 3RK1 901-1KA00 sealing caps.
Ground terminal	Pin 5 of each M12 socket is connected to the grounding wrist strap in the mounting plate using a pin
Ambient temperature	°C -25 ... +85
Storage temperature	°C -40 ... +85
Number of I/O sockets	8
Status displays	
• Display of I/Os	Yellow LED
• Display of U_{aux}	Green LED
• Display of AS-Interface/diagnostics	Green/red LED
Mounting	Using mounting plate for K60 compact module

Note:

All K60 compact modules are delivered with high-grade steel screws/sockets.

An external additional supply (AUX POWER) of 20 to 30 V DC is required for the supply of the output circuits. The additional supply must comply with VDE 0106 (PELV), safety class III.

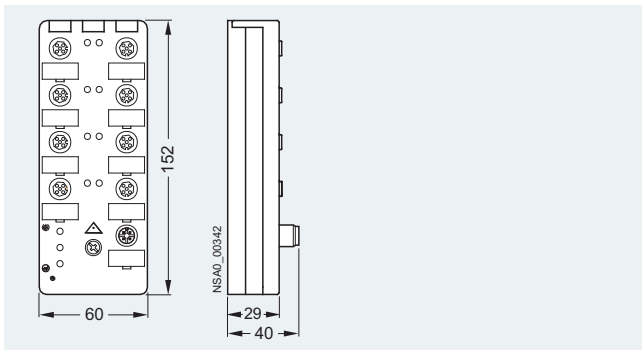
Dimensional drawings

I/O module

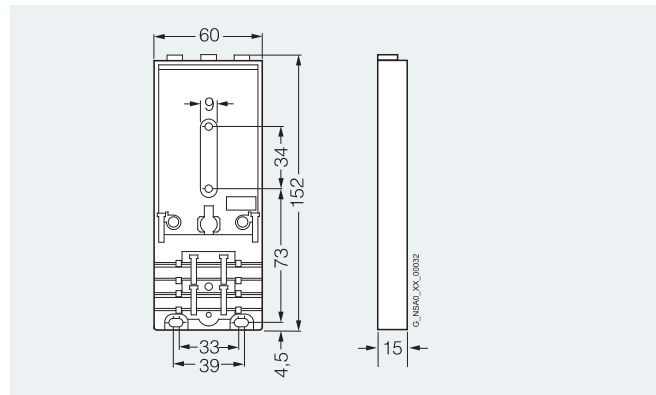

3RK1 901-0CB01 mounting plate for standard rail mounting

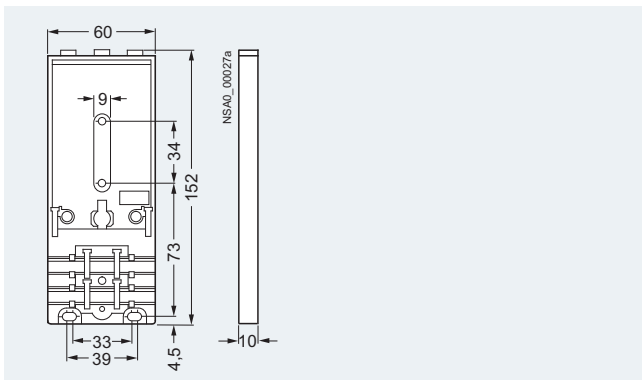

3RK1 901-0CA00 mounting plate for wall mounting

AS-Interface

Slaves

I/O modules for operation in the field
Digital I/O modules, IP67 - K45

Overview

The K45 compact modules are the ideal supplement to the K60 large compact modules, which have proven their worth in industry. They are the logical consequence for rounding off the bottom end of the existing product range.

The acclaimed advantages of the existing K60 compact modules are fully emulated by the far smaller K45 modules. Their footprint is the same as that of the user modules. However, they have a mounting depth which is only two-thirds of the user module and hence an exact match for the compact module family.

Yet in spite of these small dimensions all the modules have large labels and an integrated addressing socket.

Two mounting plates are offered for the K45 compact modules:

- The mounting plate for wall mounting has a hole arrangement that is identical to that of the K60 compact modules. This means that K60 compact modules can be mounted together with K45 modules in an aligned arrangement. The flat cables can be inserted in the recesses of the mounting plates where they cause no hindrance.
- The mounting plate for standard rail mounting has a hole arrangement that is identical to that of the user modules.

Mounting the flat cables is now easier than ever. The yellow and black AS-Interface flat cable can be inserted into the mounting plates from the left or right regardless of the position of the coding lug. The correct polarity of the applied voltages is always guaranteed.

Sensors/actuators are connected using M12 sockets. The 4I module can be ordered optionally with M8 connection sockets.

Design

Mounting

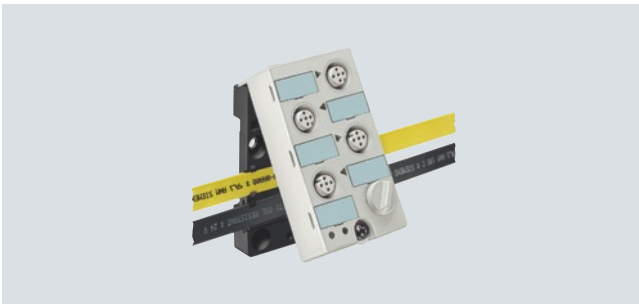

- Place the AS-Interface flat cables (yellow or yellow and black) in the corresponding cable routing of the mounting plate. Any direction is possible.
- Hook the module top in the mounting plate.
- Fasten the top to the mounting plate using just one screw.

Mounting options



- Standard rail mounting using 3RK1 901-2DA00 mounting plate.
- Wall mounting using 3RK1 901-2EA00 mounting plate.
- Mounting (horizontal and vertical fixing are both possible) on generally available profile systems using screw-on sliding blocks (max. M5, not included in scope of supply) on 3RK1 901-2EA00 or 3RK1 901-2DA00 mounting plate.

Addressing

Addressing is performed using the integrated addressing socket.

The M12 sockets which are not required must be closed with 3RK1 901-1KA00 sealing caps in order to guarantee the quoted degree of protection.

Technical specifications

Technical specifications common to all digital I/O modules IP67 – K45

Operational voltage acc. to AS-Interface specification	V	26.5 ... 31.6
Reverse polarity protection U AS-Interface		Built-in
Input circuit		PNP
Inputs		
• Sensor supply using AS-Interface		Short-circuit and overload resistant
• Sensors		2- and 3-conductors
• Voltage range	V	20 ... 30 ¹⁾
• Switching level High	V	≥ 10
• Input current Low/High	mA	≤ 1.5/≥ 6
Outputs		
• Type of output		Solid-state
• Short-circuit protection		Built-in
• Induction protection		Built-in
• External power supply 24 V DC		Using black AS-Interface flat cable
• Watchdog		Built-in
AS-Interface certificate		Yes (or requested for in case of new units)
Approvals		UL, CSA, shipbuilding (or requested for in case of new units)
Degree of protection		IP67 (IP65 with M8 snap-action connection)
Ground terminal		Using Pin 5 of the M12 sockets and outgoing unit using 2.8-mm flat connector (no ground terminal with M8 sockets)
Ambient temperature	°C	-25 ... +85
Storage temperature	°C	-40 ... +85
Status displays		
• Display of I/Os		Yellow LED
• Display of U_{aux}		Green LED
• Display of AS-Interface/diagnostics		Green/red dual LED
Mounting		Using mounting plate for K45 compact module

¹⁾ For 3RK2 400-1BQ20-0AA3 $U_{min} = 16.5$ V.

Note:

All K45 compact modules are delivered with high-grade steel screws/sockets.

An external additional supply (AUX POWER) of 20 to 30 V DC is required for the supply of the output circuits. The additional supply must comply with VDE 0106 (PELV), safety class III.

AS-Interface

Slaves

I/O modules for operation in the field
Digital I/O modules, IP67 - K45

		4 inputs		
		Standard slave		
		Standard assignment		
		M12	M8 screw terminal	M8 snap-action terminal
		3RK1 200-0CQ20-0AA3	3RK1 200-0CT20-0AA3	3RK1 200-0CU20-0AA3
Total current input	mA	≤ 270	≤ 270	≤ 270
Current carrying capacity for all inputs ($T_u \leq 40\text{ °C}$)	mA	200	200	200
Socket assignment of inputs		Pin 1: Sensor supply L+ Pin 3: Sensor supply L- Pin 2/4: Data input Pin 5: Ground terminal	Pin 1: Sensor supply L+ Pin 3: Sensor supply L- Pin 4: Data input	Pin 1: Sensor supply L+ Pin 3: Sensor supply L- Pin 4: Data input
Slave type		Standard slave	Standard slave	Standard slave
I/O configuration		0	0	0
ID/ID2 code		0/F	0/F	0/F
Assignment of data bits				
• Socket 1		Pin 4/2: IN1 (D0)	Pin 4: IN1 (D0)	Pin 4: IN1 (D0)
• Socket 2		Pin 4/2: IN2 (D1)	Pin 4: IN2 (D1)	Pin 4: IN2 (D1)
• Socket 3		Pin 4/2: IN3 (D2)	Pin 4: IN3 (D2)	Pin 4: IN3 (D2)
• Socket 4		Pin 4/2: IN4 (D3)	Pin 4: IN4 (D3)	Pin 4: IN4 (D3)
Number of I/O sockets		4	4	4

		4 inputs		
		A/B slave		
		Standard assignment		
		M12	M8 screw terminal	M8 screw terminal
		3RK2 200-0CQ20-0AA3	3RK2 200-0CT20-0AA3	3RK2 200-0CU20-0AA3
Total current input	mA	≤ 270	≤ 270	≤ 270
Current carrying capacity for all inputs ($T_u \leq 40\text{ °C}$)	mA	200	200	200
Socket assignment of inputs		Pin 1: Sensor supply L+ Pin 3: Sensor supply L- Pin 4/2: Data input Pin 5: Ground terminal	Pin 1: Sensor supply L+ Pin 3: Sensor supply L- Pin 4: Data input	Pin 1: Sensor supply L+ Pin 3: Sensor supply L- Pin 4: Data input
Slave type		A/B slave	A/B slave	A/B slave
I/O configuration		0	0	0
ID/ID2 code		A/0	A/0	A/0
Assignment of data bits				
• Socket 1		Pin 4/2: IN1 (D0)	Pin 4: IN1 (D0)	Pin 4: IN1 (D0)
• Socket 2		Pin 4/2: IN2 (D1)	Pin 4: IN2 (D1)	Pin 4: IN2 (D1)
• Socket 3		Pin 4/2: IN3 (D2)	Pin 4: IN3 (D2)	Pin 4: IN3 (D2)
• Socket 4		Pin 4/2: IN4 (D3)	Pin 4: IN4 (D3)	Pin 4: IN4 (D3)
Number of I/O sockets		4	4	4

	2x2 inputs -- A/B slave Y assignment M12 3RK2 200-0CQ22-0AA3	2 inputs/2 outputs Current carrying capacity of outputs: 2 A ¹⁾ Standard slave Standard assignment M12 3RK1 400-1BQ20-0AA3	2 x (1 input/1 output) Current carrying capacity of outputs: 0.2 A Standard slave Y assignment M12 3RK1 400-0GQ20-0AA3	4 x (1 input/1 output) Current carrying capacity of outputs: 0.2 A A/B slave (Spec 3.0) Y assignment M12 3RK2 400-0GQ20-0AA3
Total current input	mA ≤ 270	≤ 270	≤ 270	≤ 270
Current carrying capacity for all inputs ($T_u \leq 40^\circ\text{C}$)	mA 200	200	200 ²⁾	200 ²⁾
Reverse polarity protection U_{aux}	Does not apply	By coding	U_{aux} not required	U_{aux} not required
Socket assignment of inputs	Pin 1: Sensor supply L+ Pin 3: Sensor supply L- Pin 4/2: Data input Pin 5: Ground terminal	Pin 1: Sensor supply L+ Pin 2: Data input Pin 3: Sensor supply L- Pin 4: Data input Pin 5: Ground terminal	Pin 1: Sensor supply L+ Pin 2: Output Pin 3: Sensor supply L- Pin 4: Data input Pin 5: Ground terminal	Pin 1: Sensor supply L+ Pin 2: Output Pin 3: Sensor supply L- Pin 4: Data input Pin 5: Ground terminal
Outputs				
• Current carrying capacity per output DC 12/13 typical	A --	2 ¹⁾	0,2 ²⁾	0,2 ²⁾
• Maximum summation current per module	A --	3	0,2 ²⁾	0,2 ²⁾
Slave type	A/B slave	Standard slave	Standard slave	A/B slave (Spec 3.0)
I/O configuration	0	3	3	7
ID/ID2 code	A/0	0/F	F/F	A/7
Assignment of data bits				
• Socket 1	Pin 4: IN1 (D0) Pin 2: IN2 (D1)	Pin 4/2: IN1 (D0)	Pin 4: IN1 (D0) Pin 2: OUT3 (D2)	Pin 4: IN1 (D0) Pin 2: OUT1 (D0)
• Socket 2	--	Pin 4/2: IN2 (D1)	--	Pin 4: IN2 (D1) Pin 2: OUT2 (D1)
• Socket 3	--	Pin 4: OUT3 (D2)	--	Pin 4: IN3 (D2) Pin 2: OUT3 (D2)
• Socket 4	Pin 4: IN3 (D2) Pin 2: IN4 (D3)	Pin 4: OUT4 (D3)	Pin 4: IN2 (D1) Pin 2: OUT4 (D3)	Pin 4: IN4 (D3) Pin 2: OUT4 (D3)
Number of I/O sockets	2	4	2	4

¹⁾ The typical current carrying capacity per output increases with version "E12" from 1.5 to 2 A (available since approx. 07/2003).

²⁾ Summation current for all inputs and outputs max. 200 mA.

	4 outputs Current carrying capacity of outputs: 1 A Standard slave Standard assignment M12 3RK1 100-1CQ20-0AA3	3 outputs Current carrying capacity of outputs: 1 A A/B slave Standard assignment M12 3RK2 100-1EQ20-0AA3	2 outputs/2 inputs Current carrying capacity of outputs: 2 A A/B slave Standard assignment M12 3RK2 400-1BQ20-0AA3
Total current input	mA ≤ 45	≤ 45	≤ 270
Current carrying capacity for all inputs ($T_u \leq 40^\circ\text{C}$)	mA 200	200	200
Reverse polarity protection U_{aux}	By coding	By coding	By coding
Socket assignment of inputs	--	--	Pin 1: Sensor supply L+ Pin 2: Data input Pin 3: Sensor supply L Pin 4: Data input Pin 5: Ground terminal
Outputs			
• Current carrying capacity per output DC 12/13 typical	A 1	1	2
• Maximum summation current per module	A 3	3	3
Slave type	Standard slave	A/B slave	A/B slave
I/O configuration	8	8	B
ID/ID2 code	0/F	A/0	A/0
Assignment of data bits			
• Socket 1	Pin 4: OUT1 (D0)	Pin 4: OUT1 (D0)	Pin 4/2: IN3 (D2)
• Socket 2	Pin 4: OUT2 (D1)	Pin 4: OUT2 (D1)	Pin 4/2: IN4 (D3)
• Socket 3	Pin 4: OUT3 (D2)	Pin 4: OUT3 (D2)	Pin 4: OUT1 (D0)
• Socket 4	Pin 4: OUT4 (D3)	Not available	Pin 4: OUT2 (D1)
Number of I/O sockets	4	3	4

AS-Interface

Slaves

I/O modules for operation in the field
Digital I/O modules, IP67 - K45

	K45 mounting plates For wall mounting 3RK1 901-2EA00	For standard rail mounting 3RK1 901-2DA00
Ambient temperature °C	-40 ... +85	-40 ... +85
Degree of protection	IP67 with screw-mounted K45 compact module	IP67 with screw-mounted K45 compact module
Connection methods	For shaped AS-Interface cable, contacting using insulation displacement terminals integrated in the compact module	For shaped AS-Interface cable, contacting using insulation displacement terminals integrated in the compact module
Mounting	<ul style="list-style-type: none"> • Wall mounting • On profile system (corresponding sliding blocks required) • Hole spacing compatible with K60 mounting plate 	<ul style="list-style-type: none"> • Standard rail mounting/wall mounting • On profile system (corresponding sliding blocks required) • Hole spacing compatible with FK/FK-E coupling module (user module)
Cable entry	Insertion of AS-Interface cable, yellow and black, possible from any direction	Insertion of AS-Interface cable, yellow and black, possible from any direction

Dimensional drawings

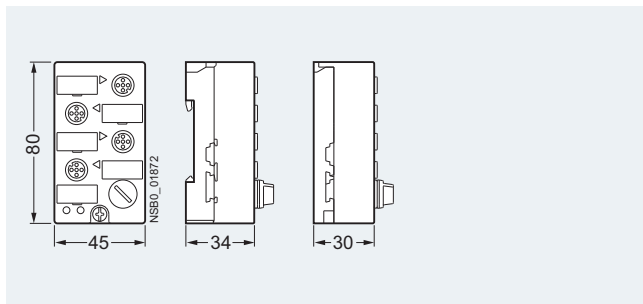

I/O module

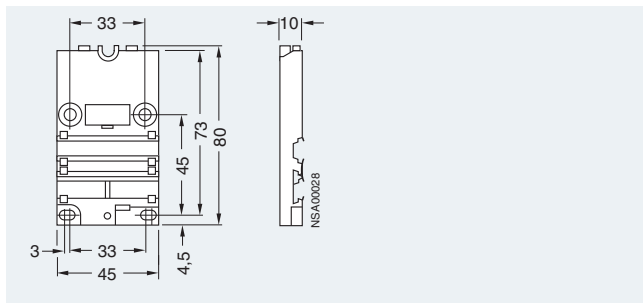

3RK1 901-2EA00
Mounting plate for wall mounting
Arrangement and drilled holes identical to that of the K60 compact module

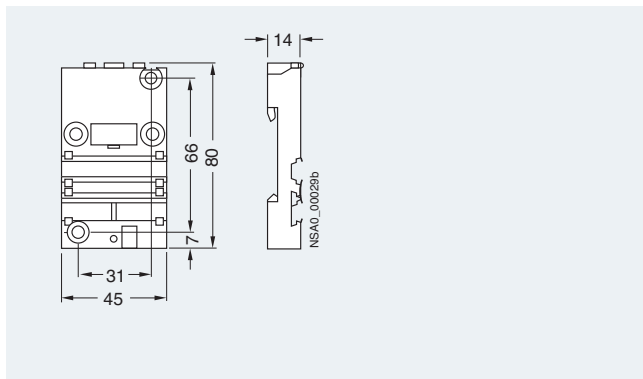

3RK1 901-2DA00
Mounting plate for standard rail mounting
Arrangement and drilled holes identical to that of the user module

Schematics

Terminal assignment for input (M8 socket)

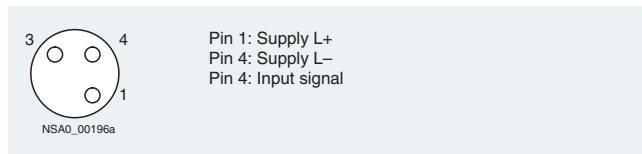

Standard assignment

Terminal assignment for input (M12 socket)

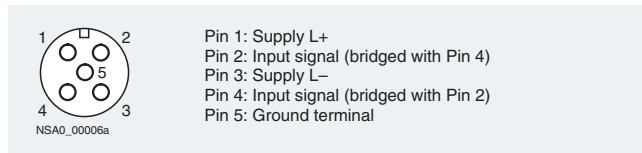

Standard assignment

Terminal assignment for input (M12 socket)

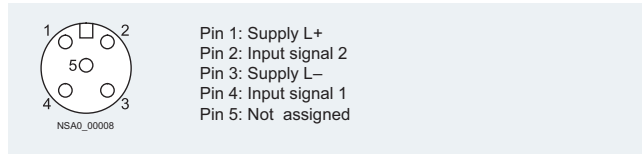

Y assignment

Terminal assignment for output (M12 socket)

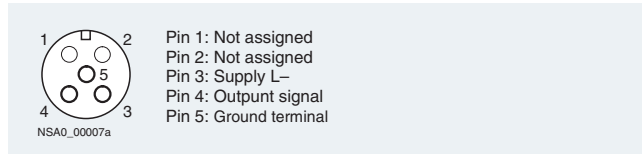

Standard assignment

Overview

Use in tight spaces



The K20 compact module range rounds off the AS-Interface compact modules with a particularly slim design and a width of a mere 20 mm. Thanks to its extremely compact dimensions, these modules are particularly suited for handling machine applications in the field of production engineering where modules need to be arranged in the smallest of spaces.

Robotics is yet another application area. Instead of the AS-Interface flat cable, the K20 modules are connected to AS-Interface over a round cable with M12 cable box. The AS-Interface bus cable and the 24 V DC auxiliary power supply are routed in this case in a shared round cable. This enables extremely compact installation.

The flexibility of the round cable means that it can also be used on moving machine parts without any problems. The K20 modules are also ideal for such applications as their non-encapsulated design makes them particularly light in weight.

In applications with tow chains, many users rely on placing the AS-Interface bus cable in a round cable. In this case, the K20 modules support direct connection to the round cable. No flat to round cable adapter is required.

The K20 compact module range includes standard AS-Interface modules, as well as an ASIsafe version for the connection of fail-safe sensors, such as EMERGENCY-STOP pushbuttons or protective door monitoring. All standard AS-Interface K20 modules support, as far as technically possible, the expanded address mode (A/B addresses) according to AS-Interface specification 2.1, which enables connection of 62 stations to an AS-Interface network. The K20 module with four inputs and four outputs works in expanded address mode according to AS-Interface specification 3.0 which, for the first time, supports four outputs with an A/B slave, thus enabling 248 inputs and 248 outputs in a fully expanded AS-Interface network.

For particularly space-saving dimensions, the sensors and actuators are connected over M8 plug-in connectors. Alternatively, M12 connectors with Y assignment can be used.

Design

Mounting

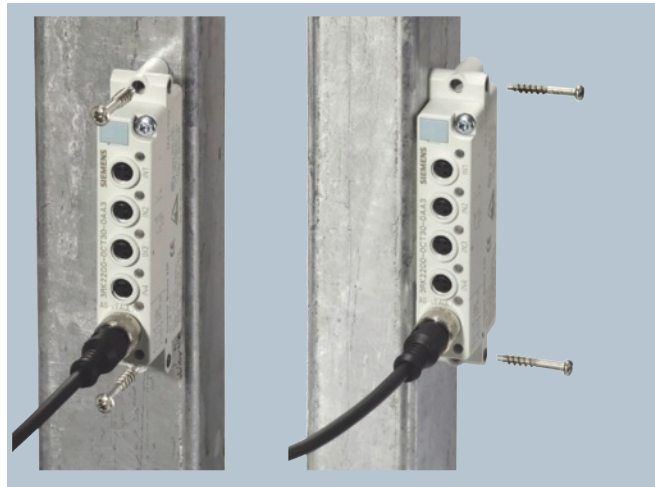

Mounting the K20 modules: On front (see left) or on side (see right)

The K20 modules are mounted with two screws. No mounting plate is required. The modules can be mounted either on the front or the side. This flexibility allows users to place them where they will be best protected and save the most space, e. g. on standard mounting rails.

Addressing

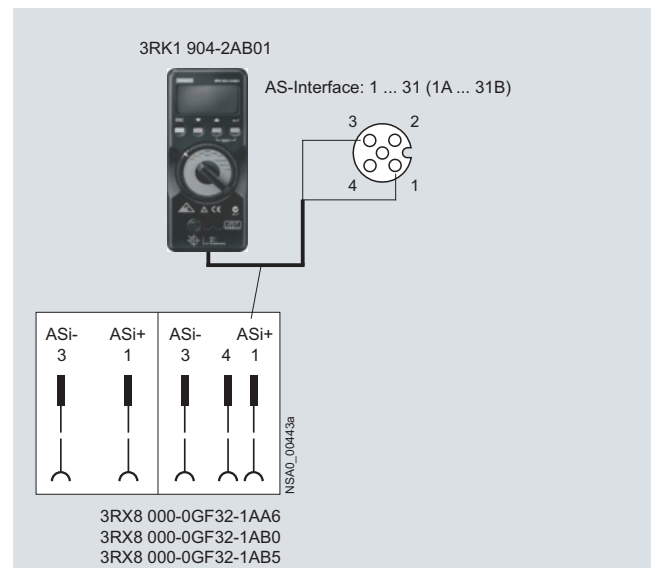

Addressing the K20 modules

Addressing the K20 modules is performed using the same socket as for the bus connection. The module is connected to the 3RK1 904-2AB01 addressing unit using a standard M12 connecting cable (2- or 3-pole), e. g. 3RX8 000-0GF32-1AB5. If the older version of the 3RK1 904-2AB00 addressing unit is used, a special addressing cable (3RK1 901-3RA00) is required for connecting to the addressing unit. When the addressing operation is completed, the addressing cable is removed again and the module connected to the bus cable. Never use a 4-pole or 5-pole connecting cable for the addressing.

AS-Interface

Slaves

I/O modules for operation in the field Digital I/O modules, IP67 - K20

All K20 modules (except ASIsafe versions) support, as far as technically possible, the extended address mode and can be addressed with an A or B address. Up to 62 slaves can be connected accordingly to one AS-Interface network. The version with four inputs and four outputs (3RK2 400-1CT30-0AA3) works according to the new AS-Interface specification 3.0. With specification 3.0 even A/B slaves can have four outputs (instead of only three possible up to now with specification 2.1). Please note, however, that these modules can be used only with a new master according to AS-Interface Specification 3.0 (e. g. the new DP/AS-i LINK Advanced) and that the cycle times for the outputs can extend to max. 20 ms.

Connection



AS-Interface M12 feeders and distributor, closed



AS-Interface M12 feeders and distributor, open

A new series of AS-Interface distributors and M12 feeders is available for easy connection of the K20 modules to the AS-Interface flat cable:

AS-Interface distributors

Like the AS-Interface 3RK1 901-1NN00 standard distributor, the new AS-Interface 3RK1 901-1NN10 compact distributor enables the AS-Interface flat cable to be distributed to several lines. The compact distributor can be used for a current carrying capacity up to 6 A. It is characterized by particularly simple handling:

- Insert the cable
- Swing shut and
- Secure in the closed position with only one captive screw.

No additional seals are required for the compact distributor. The AS-Interface flat cable must always be routed through the compact distributor, i. e. you must never terminate it in the compact distributor. For higher currents or for when one of the two flat cables has to be terminated in the distributor, use the standard distributor.

AS-Interface M12 feeders

AS-Interface M12 feeders are available in the same design as the compact distributor. These versions are required for transition from the AS-Interface flat cable to a round cable. The spectrum covers AS-Interface M12 feeders with various cable lengths (1 and 2 m) and distinguishes between M12 feeders for AS-i/ U_{aux} for connecting I/O modules and M12 feeders for AS-Interface without U_{aux} for connecting modules with inputs. These AS-Interface M12 feeders are just as easy to use as the AS-Interface compact distributor. The flat cable must always be routed through the M12 distributors, i. e. you must never terminate it in the M12 distributors. For cases requiring the AS-Interface flat cable to be terminated in the M12 feeder, use the standard M12 feeder (3RX9 801-0AA00) or the quadruple M12 feeder (3RK1 901-1NR00).

The various options for connecting the K20 modules to the AS-Interface bus cable and the 24 V DC auxiliary voltage are presented in the following table:

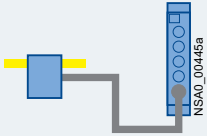
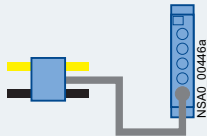
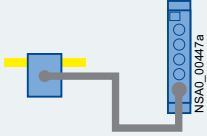
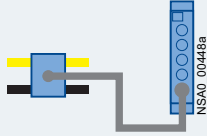
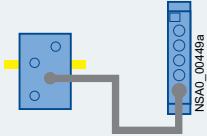
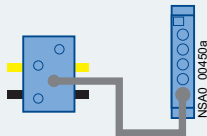
	Digital I/O modules, IP67 – K20		AS-i / U_{aux}
	AS-i without U_{aux} 4DI, M8 3RK2 200-OCT30-0AA3 4DI, M12 3RK2 200-OCQ30-0AA3 2FDI, M12 3RK1 205-0BQ30-0AA3		AS-i / U_{aux} 2DI/2DO, M8 3RK2 400-1BT30-0AA3 2DI/2DO, M12 3RK2 400-1BQ30-0AA3 4DI/4DO, M8 3RK1 400-1CT30-0AA3 3RK2 400-1CT30-0AA3
K20 modules <ul style="list-style-type: none"> Plus M12 feeder with integrally extruded cable 	 <p>M12 feeder: 3RK1 901-1NR11 (1 m) or 3RK1 901-1NR12 (2 m)</p>	 <p>M12 feeder: 3RK1 901-1NR21 (1 m) or 3RK1 901-1NR22 (2 m)</p>	
K20 modules <ul style="list-style-type: none"> Plus M12 feeder with socket Plus separate M12 cable 	 <p>M12 feeder: 3RX9 801-0AA00 3RK1 901-1NR10</p> <p>M12 cable: 3RX8 000-0GF42-1AA6 (0.6 m) 3RX8 000-0GF42-1AB0 (1.0 m) 3RX8 000-0GF42-1AB5 (1.5 m)</p>	 <p>M12 feeder: 3RK1 901-1NR20</p> <p>M12 cable: 3RX8 000-0GF42-1AA6 (0.6 m) 3RX8 000-0GF42-1AB0 (1.0 m) 3RX8 000-0GF42-1AB5 (1.5 m)</p>	
K20 modules <ul style="list-style-type: none"> Plus quadruple M12 feeder Plus separate M12 cable 	 <p>M12 feeder: 3RK1 901-1NR00</p> <p>M12 cable: 3RX8 000-0GF42-1AA6 (0.6 m) 3RX8 000-0GF42-1AB0 (1.0 m) 3RX8 000-0GF42-1AB5 (1.5 m)</p>	 <p>M12 feeder: 3RK1 901-1NR00</p> <p>M12 cable: 3RX8 000-0GF42-1AA6 (0.6 m) 3RX8 000-0GF42-1AB0 (1.0 m) 3RX8 000-0GF42-1AB5 (1.5 m)</p>	

To connect the feeder and the K20 module over distances > 2 m it is also possible to use freely configurable cables with an M12 cable box and an open cable end, which are fitted with an M12 plug (straight version: 3RX8 000-0CD45, angled: 3RX8 000-0CE45) and connected to the feeder.

This cable is available in two versions:

- 3RX8 000-0CB42-1AF0: 5 m long, with M12 cable box
- 3RX8 000-0CC42-1AF0: 5 m long, with M12 angle cable box

To connect more than one K20 module to one spur line, the spur line can be split again using a T distributor (3RK1 901-1TR00).

AS-Interface

Slaves

I/O modules for operation in the field Digital I/O modules, IP67 - K20

Please note the following boundary conditions:

- The configuration guidelines for AS-Interface apply. For all M12 connecting cables the maximum permissible current is limited to 4 A. The cross-section of these cables amounts to just 0.34 mm². For connection of the K20 modules, the aforementioned M12 connecting cables can be used for the spur lines. The voltage drop caused by the ohmic resistance (approx. 0.11 Ω/m) must be taken into account.
- For round cable connections with shared AS-i and U_{aux} in a single cable, the following maximum lengths apply:
 - Per spur line from feeder to module: maximum 5 m
 - Total of all round cable segments in an AS-Interface network: maximum 20 m

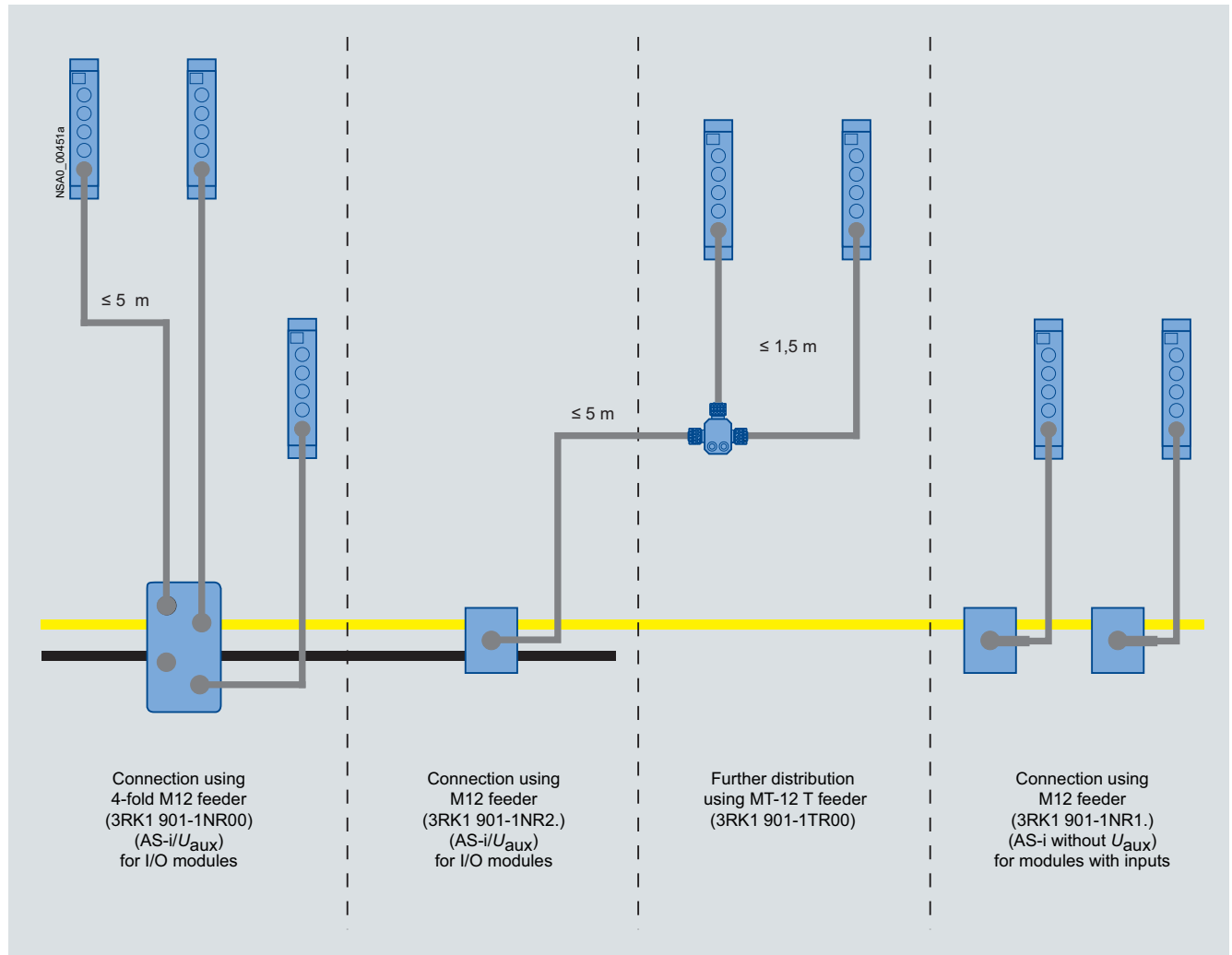

Connection examples for K20 modules

Technical specifications

	Digital I/O module, IP67 – K20			
	4 inputs M8 Standard assignment 3RK2 200-OCT30-0AA3	4 inputs M12 Y assignment 3RK2 200-OCQ30-0AA3	2 inputs/2 outputs M8 Standard assignment 3RK2 400-1BT30-0AA3	4 outputs M8 Standard assignment 3RK2 100-1CT30-0AA3
Slave type	A/B slave	A/B slave	A/B slave	A/B slave
Operational voltage acc. to AS-Interface specification	V 26.5 ... 31.6	26.5 ... 31.6	26.5 ... 31.6	26.5 ... 31.6
Total current input	mA ≤ 270	≤ 270	≤ 270	≤ 60
Input circuit	PNP	PNP	PNP	--
Inputs				
• Sensor supply using AS-Interface	Short-circuit and overload resistant 2- and 3-conductors	Short-circuit and overload resistant 2- and 3-conductors	Short-circuit and overload resistant 2- and 3-conductors	--
• Sensors				--
• Voltage range	V 16.5... 30	16.5 ... 30	16.5 ... 30	--
• Current carrying capacity for all inputs (T _u ≤ 40 °C)	mA 200	200	150	--
• Current carrying capacity for all inputs (T _u ≤ 55 °C)	mA 150	150	70	--
• Switching level High	V ≥ 10	≥ 10	≥ 10	--
• Input current Low/High	mA ≤ 1.5/≥ 6	≤ 1.5/≥ 6	≤ 1.5/≥ 6	--
• Socket assignment of inputs				
- Pin 1	Sensor supply L+	Sensor supply L+	Sensor supply L+	--
- Pin 2	--	Data input 2	--	--
- Pin 3	Sensor supply L-	Sensor supply L-	Sensor supply L-	--
- Pin 4	Data input	Data input 1	Data input	--
- Pin 5	--	Not assigned	--	--
Outputs				
• Type of output	--	--	Solid-state	Solid-state
• Current carrying capacity per output DC 12/13 typical	A --	--	1	1
• Maximum summation current per module	A --	--	1	1
• Socket assignment of outputs	--	--	Pin 3: "-" Pin 4: Output	Pin 3: "-" Pin 4: Output
• Short-circuit protection	--	--	Built-in	Built-in
• Induction protection	--	--	Built-in	Built-in
• External power supply 24 V DC	--	--	Shared round cable connection with AS-Interface connection through M12 female connector	
• Watchdog	--	--	Built-in	Built-in
I/O configuration	0	0	B	7
ID/ID2 code	A/0	A/2	A/0	A/7
Assignment of data bits				
• Socket 1	Pin 4: IN1 (D0)	Pin 4: IN1 (D0)	Pin 4: IN3 (D2)	Pin 4: OUT1 (D0)
• Socket 2	Pin 4: IN2 (D1)	Pin 2: IN2 (D1) Pin 4: IN3 (D2) Pin 2: IN4 (D3)	Pin 4: IN4 (D3)	Pin 4: OUT2 (D1)
• Socket 3	Pin 4: IN3 (D2)	Not available	Pin 4: OUT1 (D0)	Pin 4: OUT3 (D2)
• Socket 4	Pin 4: IN4 (D3)	Not available	Pin 4: OUT2 (D1)	Pin 4: OUT4 (D3)
• Socket 5	Not available	Not available	Not available	Not available
• Socket 6	Not available	Not available	Not available	Not available
• Socket 7	Not available	Not available	Not available	Not available
• Socket 8	Not available	Not available	Not available	Not available
AS-Interface certificate	Yes	Yes	Yes	Yes
Approvals	UL/CSA	UL/CSA	UL/CSA	UL/CSA
Degree of protection	IP65/IP67	IP65/IP67	IP65/IP67	IP65/IP67
Ground terminal	Not available	Not available	Not available	Not available
Ambient temperature	°C -25 ... +70	-25 ... +70	-25 ... +70	-25 ... +70
Storage temperature	°C -40 ... +85	-40 ... +85	-40 ... +85	-40 ... +85
Number of I/O sockets	4	2	4	4
Status displays				
• Display of I/Os	Yellow LED	Yellow LED	Yellow LED	Yellow LED
• Display of U _{aux}	Not required	Not required	Green LED	Green LED
• Display of AS-Interface/diagnostics	Green/red LED	Green/red LED	Green/red LED	Green/red LED
Additional supply	--	--	An external additional supply (AUX POWER) of 20 to 30 V DC is required for the supply of the output circuits. The additional supply must comply with VDE 0106 (PELV), safety class III.	

AS-Interface

Slaves

I/O modules for operation in the field
Digital I/O modules, IP67 - K20

	Digital I/O module, IP67 – K20			
	2 inputs/2 outputs M12 Y assignment 3RK2 400-1BQ30-0AA3	4 inputs/4 outputs M8 Standard assignment 3RK1 400-1CT30-0AA3	4 inputs/4 outputs M8 Standard assignment 3RK2 400-1CT30-0AA3	2 inputs, safe M12 Y-II assignment 3RK1 205-0BQ30-0AA3
Slave type	A/B slave	Standard slave	A/B slave (specification 3.0)	Standard slave
Operational voltage acc. to AS-Interface specification	V 26.5 ... 31.6	26.5 ... 31.6	26.5 ... 31.6	26.5 ... 31.6
Total current input	mA ≤ 270	≤ 270	≤ 270	≤ 45
Input circuit	PNP	PNP	PNP	For mechanical switching contacts
Inputs				
• Sensor supply using AS-Interface	Short-circuit and overload resistant	Short-circuit and overload resistant	Short-circuit and overload resistant	Not applicable
• Sensors	2- and 3-conductors	2- and 3-conductors	2- and 3-conductors	Mechanical switching contact
• Voltage range	V 16.5 ... 30	16.5 ... 30	16.5 ... 30	Not applicable
• Current carrying capacity for all inputs (T _u ≤ 40 °C)	mA 150	200	200	Not applicable
• Current carrying capacity for all inputs (T _u ≤ 55 °C)	mA 70	150	150	Not applicable
• Switching level High	V ≥ 10	≥ 10	≥ 10	Not applicable
• Input current Low/High	mA ≤ 1.5/≥ 6	≤ 1.5/≥ 6	≤ 1.5/≥ 6	-- / I _{peak} ≥ 5
• Socket assignment of inputs	Pin 1: Sensor supply L+ Pin 2: Data input 2 Pin 3: Sensor supply L- Pin 4: Data input 1 Pin 5: Not assigned	Pin 1: Sensor supply L+ Pin 3: Sensor supply L- Pin 4: Data input	Pin 1: Sensor supply L+ Pin 3: Sensor supply L- Pin 4: Data input	Pin 1/2: F-IN1 Pin 3/4: F-IN2 Pin 5: Not assigned
Outputs				
• Type of output	Solid-state	Solid-state	Solid-state	--
• Current carrying capacity per output DC 12/13 typical	A 1	1	1	--
• Maximum summation current per module	1	2 at T = 40 °C	2 at T = 40 °C	--
• Socket assignment of outputs	Pin 2: Output 2 Pin 3: "-" Pin 4: Output 1	Pin 3: "-" Pin 4: Output	Pin 3: "-" Pin 4: Output	--
• Short-circuit protection	Built-in	Built-in	Built-in	--
• Induction protection	Built-in	Built-in	Built-in	--
• External power supply 24 V DC	Shared round cable connection with AS-Interface connection through M12 female connector			--
• Watchdog	Built-in	Built-in	Built-in	--
I/O configuration	B	7	7	0
ID/ID2 code	A/2	0/E	A/7	B/0
Assignment of data bits				
• Socket 1	Pin 4: IN3 (D2) Pin 2: IN4 (D3)	Pin 4: IN1 (D0)	Pin 4: IN1 (D0)	Pin 1/2: F-IN1 Pin 3/4: F-IN2 Pin 5: Not assigned
• Socket 2	Pin 4: OUT1 (D0) Pin 2: OUT2 (D1)	Pin 4: IN2 (D1)	Pin 4: IN2 (D1)	Pin 1/2: F-IN2 Pin 3/4: Not assigned Pin 5: Not assigned
• Socket 3	Not available	Pin 4: IN3 (D2)	Pin 4: IN3 (D2)	Not available
• Socket 4	Not available	Pin 4: IN4 (D3)	Pin 4: IN4 (D3)	Not available
• Socket 5	Not available	Pin 4: OUT1 (D0)	Pin 4: OUT1 (D0)	Not available
• Socket 6	Not available	Pin 4: OUT2 (D1)	Pin 4: OUT2 (D1)	Not available
• Socket 7	Not available	Pin 4: OUT3 (D2)	Pin 4: OUT3 (D2)	Not available
• Socket 8	Not available	Pin 4: OUT4 (D3)	Pin 4: OUT4 (D3)	Not available
AS-Interface certificate	Yes	Yes	Yes	Yes
Approvals	UL/CSA	UL/CSA	UL/CSA	UL/CSA
Degree of protection	IP65/IP67	IP65/IP67	IP65/IP67	IP65/IP67
Ground terminal	Not available	Not available	Not available	Not available
Ambient temperature	°C -25 ... +70	-25 ... +70	-25 ... +70	-25 ... +70
Storage temperature	°C -40 ... +85	-40 ... +85	-40 ... +85	-40 ... +85
Number of I/O sockets	2	8	8	2
Status displays				
• Display of I/Os	Yellow LED	Yellow LED	Yellow LED	Yellow LED
• Display of U _{aux}	Green LED	Green LED	Green LED	Not required
• Display of AS-Interface/diagnostics	Green/red LED	Green/red LED	Green/red LED	Green/red LED
Additional supply	An external additional supply (AUX POWER) of 20 to 30 V DC is required for the supply of the output circuits. The additional supply must comply with VDE 0106 (PELV), safety class III.			--
Special master requirements	--	--	A master according to AS-Interface specification 3.0 is required for this module	--

I/O modules for operation in the field Digital I/O modules, IP67 - K20

2

Dimensional drawings

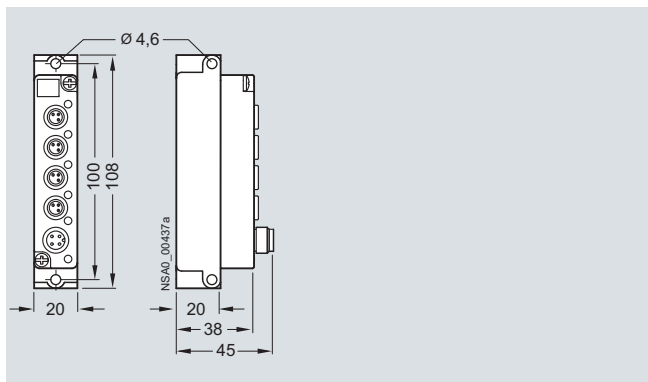

K20 module, four inputs, M8 (3RK2 200-OCT30-0AA3)
K20 module, two inputs/two outputs, M8 (3RK2 400-1BT30-0AA3)

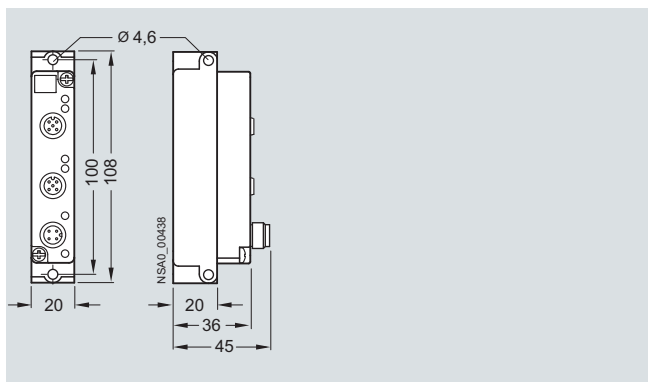

K20 module, four inputs, M12 (3RK2 200-OCQ30-0AA3)
K20 module, two inputs/two outputs, M12 (3RK2 400-1BQ30-0AA3)
K20 module, two safety inputs, M12 (3RK1 205-0BQ30-0AA3)

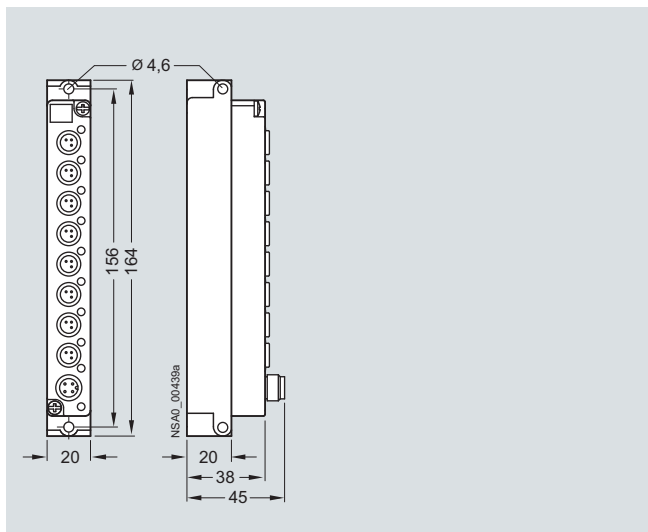

K20 module, four inputs/four outputs, M8 (3RK. 400-1CT30-0AA3)

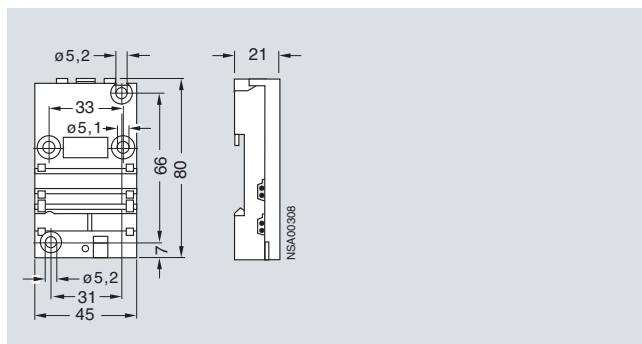

AS-Interface standard distributor, for AS-Interface flat cable (3RK1 901-1NN00)

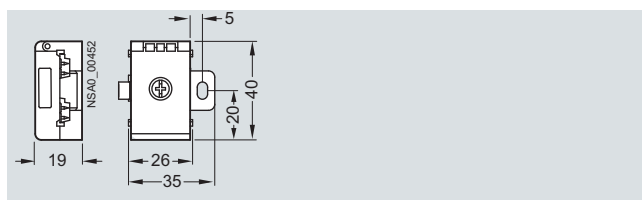

AS-Interface compact distributor, for AS-Interface flat cable (3RK1 901-1NN10)

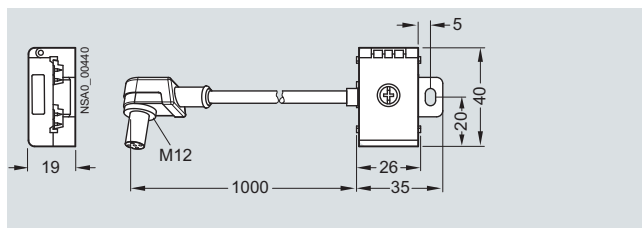

AS-Interface M12 feeder, AS-i/U_{aux}, M12 cable box, 1 m cable length (3RK1 901-1NR21)

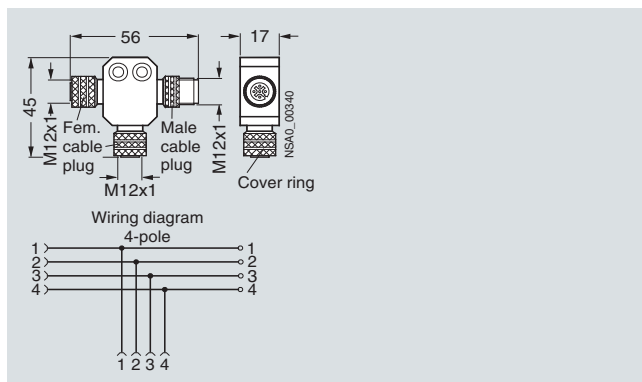

M12-T distributor (3RK1 901-1TR00)

AS-Interface

Slaves

I/O modules for operation in the field
Digital I/O modules, IP67 - K20

Schematics

Inputs

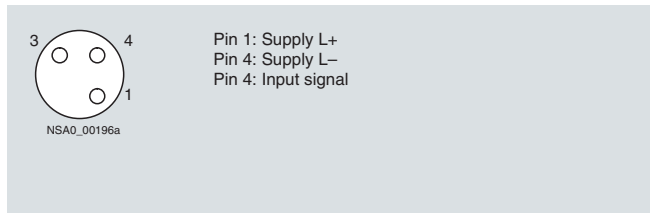

Terminal assignment for input, M8 socket, standard assignment

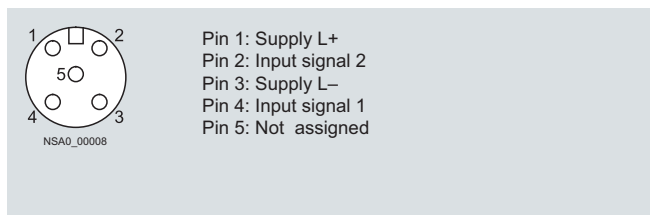

Terminal assignment for input, M12 socket, Y assignment

Outputs

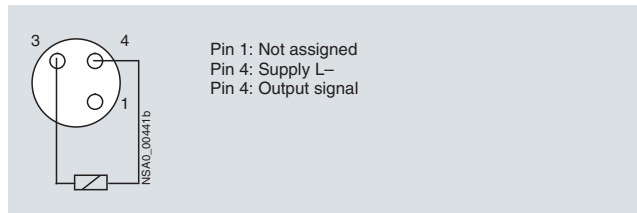

Terminal assignment for output, M8 socket, standard assignment

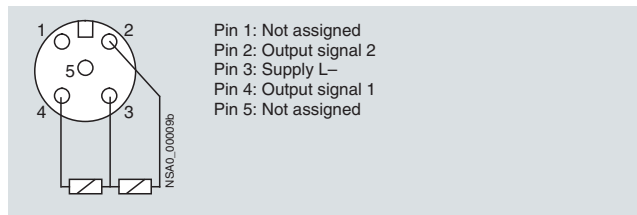

Terminal assignment for output, M12 socket, Y assignment

NSA0_00442a

Socket	Assignment / data sheets / function
1	Pin 1 and Pin 2: Influences the bits D0 and D1 = Channel 1 Pin 3 and Pin 4: Influences the bits D2 and D3 = Channel 2 Pin 5 not assigned
2	Pin 1 and Pin 2: Influences the bits D2 and D3 = Channel 2 Pin 3, Pin 4 and Pin 5 not assigned

Terminal assignment for safety input, M12 socket, Y-II assignment

Overview



AS-Interface analog modules from the K60 compact series detect or issue analog signals locally. These modules are linked to the higher-level controller through an AS-Interface master according to specification 2.1 or specification 3.0.

The analog modules are divided into five groups:

- Input module for sensors with current signal
- Input module for sensors with voltage signal
- Input module for sensors with thermal resistor
- Output module for current actuators
- Output module for voltage actuators

The input modules according to profile 7.3/7.4 are available with two or four input channels. It is possible in addition to convert the two-channel module to using only one input channel, thus enabling very short times before the analog value is available. The conversion is effected by means of a jumper plug at socket 3. The transmission times achieved with analog modules according to Profile 7.A.9 are shorter by half than those achieved with Profile 7.3/7.4. Operation is adjustable in this case, e. g. it is possible to choose with the ID1 Code whether the module is operated with one or two channels.

The output modules are configured as two-channel modules as standard.

The input and output channels are electrically isolated from the AS-Interface network. If sensors with a higher power requirement are to be connected, more power can be supplied through the auxiliary voltage as an alternative to the internal supply.

In the manual the modules are presented in great detail along with their technical specifications and in-depth notes on operation. Sample function blocks round off the manual.

Function

Data transfer according to analog profile 7.3/7.4

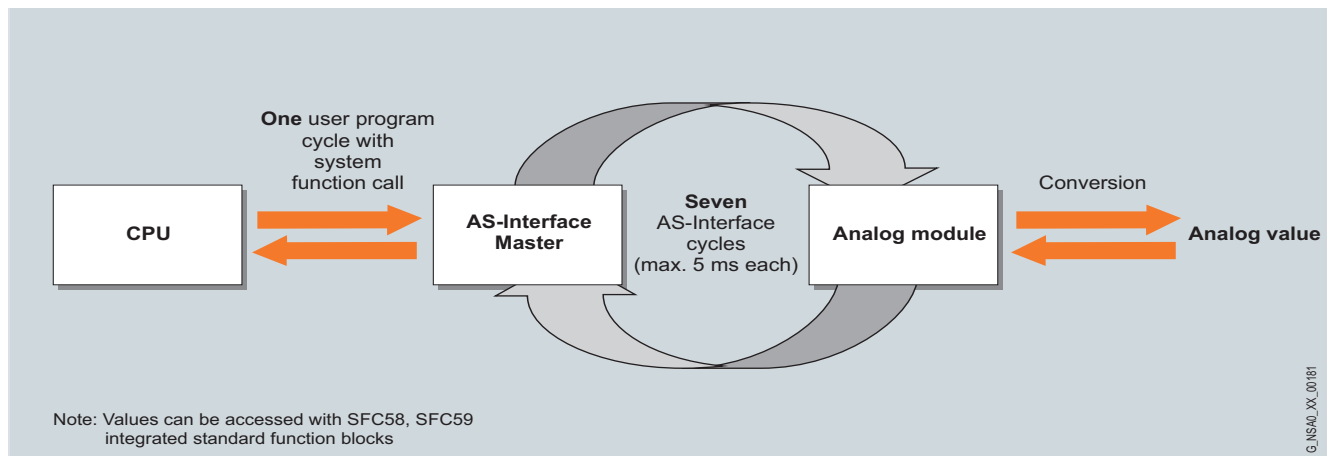

With analog profile 7.3/7.4 at least seven AS-Interface cycles must be passed through before transmission is completed. This requires the use of a master according to extended specification V2.1.

With input modules the complete analog value is then available in the AS-Interface master. Preprocessing is thus performed in the master.

With the next system function call the user program brings the analog value as one value into the user program. Hence the analog value is very quickly updated.

The analog value transmission applies in reverse order for the output modules as well.

In total this results in the following maximum times before the analog value is available with profile 7.3/7.4¹⁾:

	1 channel	2 channels	4 channels
Conversion and transmission time	Max. 95 ms	Max. 235 ms	Max. 435 ms

¹⁾ With presetting: smoothing function deactivated; line filter 50 Hz.

AS-Interface

Slaves

I/O modules for operation in the field
Analog I/O modules, IP67 - K60

Data transfer according to analog profile 7.A.9

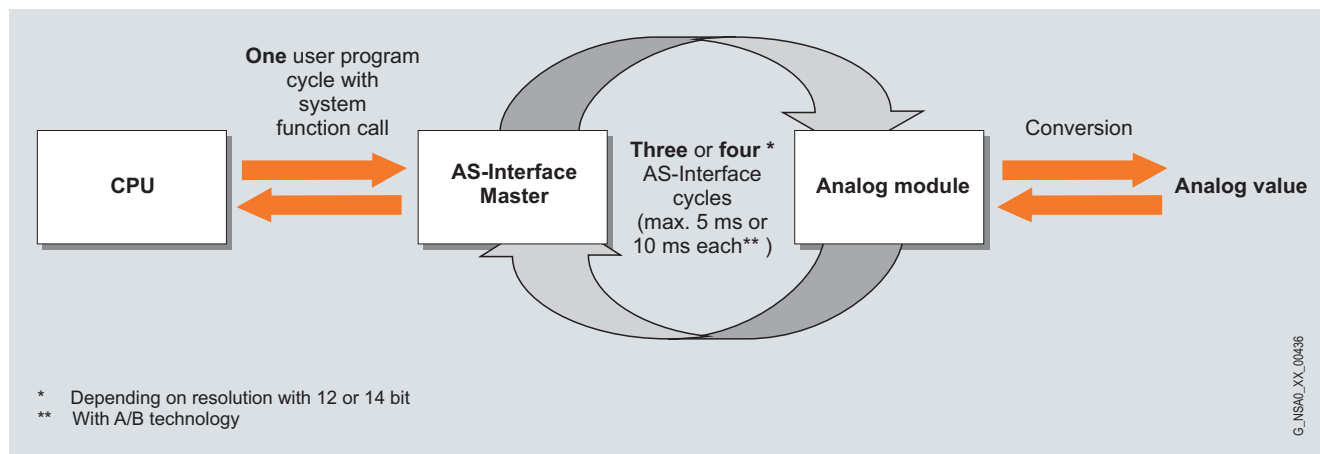

With analog profile 7.A.9, only three or four AS-Interface cycles are needed for the transmission. This requires the use of a master according to specification 3.0.

Maximum times before the analog value is available with profile 7.A.9 are offered in the manual with full details according to the mode selected (resolution, number of channels, A/B technology).

Technical specifications

	Analog I/O modules, IP67 - K60	
Slave type	Analog slave	A/B analog slave (Spec. 3.0)
Profile	7.3 D/E	7.A.9
Number format	S7	S7
Operational voltage acc. to AS-Interface specification	V 26.5 ... 31.6	26.5 ... 31.6
Total current input of the module including connection of sensors/actuators	mA 150	150
Current transfer with connection of two sensors (without U_{aux} infeed)	mA Max. 46	Max. 46
Additional supply of sensors through U_{aux}	V 24 ... 30	24 ... 30
Current transfer from U_{aux} with connection of two sensors	mA Max. 500	Max. 500
Current transfer with connection of two current/voltage actuators	mA Max. 30/max. 24	--
I/O configuration	7	7
ID code	3	A
ID2 code	D/E	9
Approvals	UL, CSA, shipbuilding	UL, CSA, shipbuilding available soon
Degree of protection	IP67 (with inserted cables)	IP67 (with inserted cables)
Ambient temperature	°C -20 ... +60	-20 ... +60
Storage temperature	°C -40 ... +85	-40 ... +85
Display of AUX PWR (U_{aux})	Green LED	Green LED
Display of AS-i	Green LED	Green LED
Display of FAULT	Red LED	Red LED
Mounting	Using mounting plate for K60 compact module	Using mounting plate for K60 compact module

I/O modules for operation in the field Analog I/O modules, IP67 - K60

Schematics

Pin assignment for input module

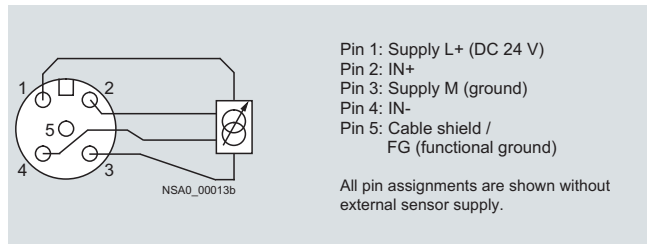

Current input for 4-wire sensor

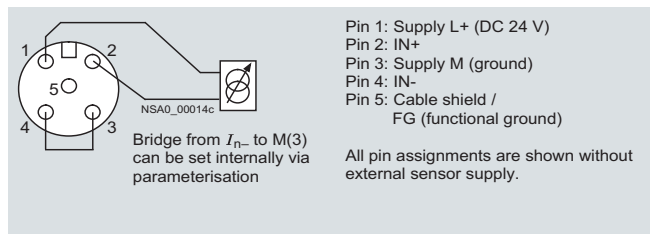

Current input for 2-wire sensor

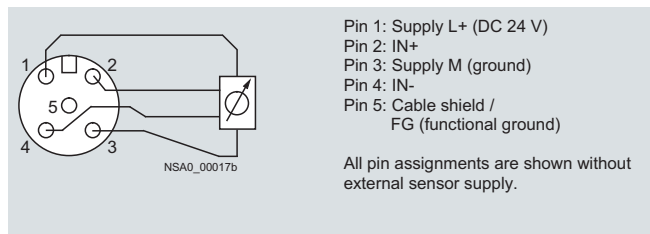

Voltage input for 4-wire sensor

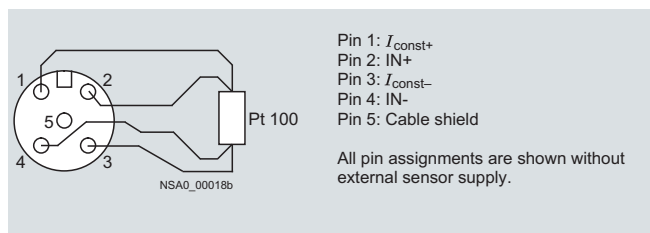

Thermal resistor for 4-wire sensor

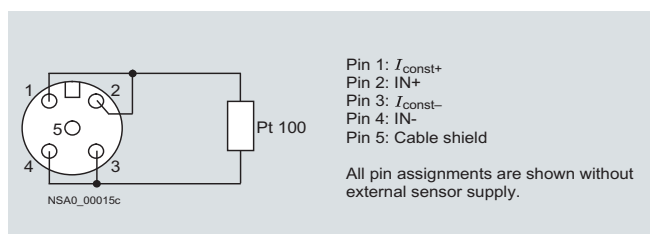

Thermal resistor for 2-wire sensor

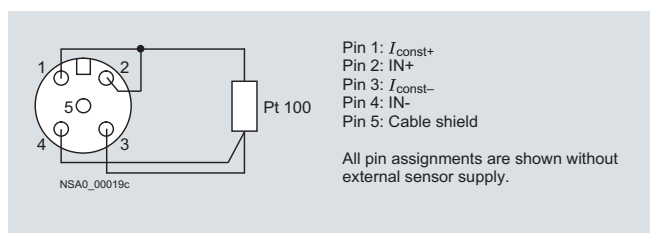

Thermal resistor for 3-wire sensor

Pin assignment for output module

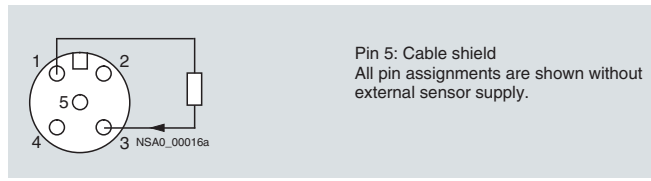

Current output

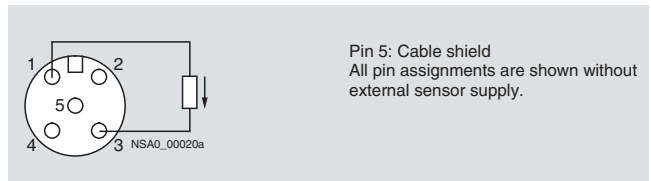

Voltage output

Connection of the 2-channel input modules for single-channel use

The 3RK1 901-1AA00 input bridge can also be used for this purpose.

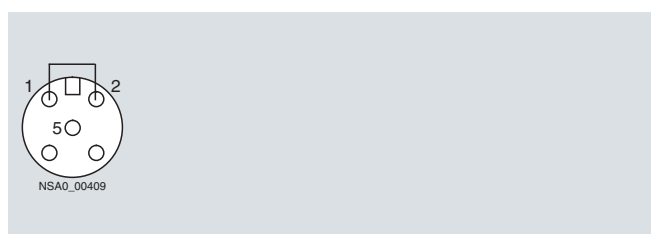

AS-Interface

Slaves

I/O modules for operation in the control cabinet, IP20

Overview

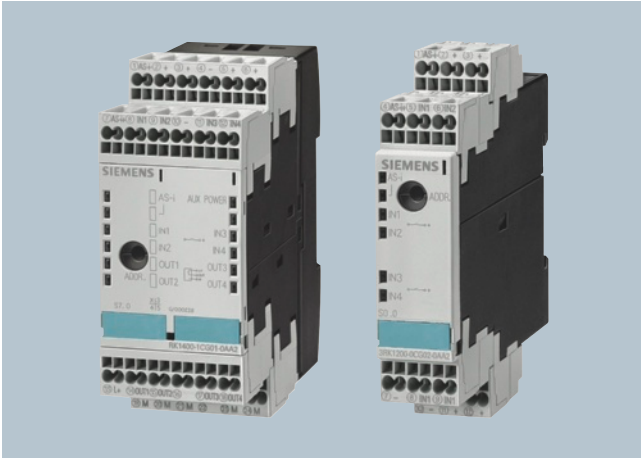

SlimLine S22.5/S45



Flat module



F90 module

For AS-Interface applications inside control cabinets there are various module series for the most diverse requirements:

- SlimLine S22.5
- SlimLine S45
- F90 module
- Flat module

All modules of these series can be snap-mounted directly on a standard mounting rail or be fastened using screws.

AS-Interface modules in IP20 have direct terminals for the AS-Interface cables and therefore do not require a base.

Series	Spectrum	Mounting on 35 mm standard mounting rail acc. to EN 60715	Wall mounting using push-in lugs (3RP1 903)	Other possibilities
SlimLine S22.5	<ul style="list-style-type: none"> • 4I (standard and A/B modules) • 4O • 2I/2O (steady-state/relay outputs) • Counters¹⁾ • Ground-fault detection modules¹⁾ 	✓	✓	--
SlimLine S45	<ul style="list-style-type: none"> • 4I/4O (steady-state/relay outputs) • 4I/4O with floating I/Os • 4I/3O (A/B modules) • 4I/4O (A/B modules Spec. 3.0) 	✓	✓	--
F90 module	<ul style="list-style-type: none"> • 4I/4O (screw terminal) • 4I/4O (connection using Combicon connector) • 16I 	✓	--	--
Flat modules	<ul style="list-style-type: none"> • 4I/4O (screw terminal) 	--	--	Integrated lugs for screw mounting

¹⁾ For more information about these modules see Catalog LV 1 --> Chapter "Systems", section "AS-Interface" --> "Slaves" --> "Modules with Special Functions" in our Mall --> section "Low-Voltage Controls" --> "SIRIUS Industrial Controls" --> "Systems" --> "AS-Interface" --> "Slaves" --> "Modules with Special Functions".

Function

Addressing

All modules of the SlimLine S22.5, S45 and F90 series and the flat module can be addressed through an integrated addressing socket in the mounted state as well. An addressing unit (3RK1 904-2AB01 AS-Interface addressing and diagnostics unit) is required for this.

LED diagnostics indications

AS-Interface modules from the SlimLine series have a large status display:

- With yellow LEDs for the switching state of the inputs and outputs
- With two LEDs or one dual LED (two-color LED) for AS-i communication (depending on the design)
- With one green LED for the auxiliary voltage U_{AUX}

The status of a module is indicated by LEDs using continuous or blinklight. This enables diagnostics at a glance. The following tables provide an overview of the LED status displays of the I/O modules.

LED status displays for SlimLine modules

AS-i	FAULT	Possible cause	Possible remedy
Green	Off	Normal operation; AS-Interface communication OK	--
Green	Red	No AS-i communication: <ul style="list-style-type: none"> • Master deactivated or offline • Slave not configured in master • Wrong slave type connected • Slave has wrong address 	Ensure AS-i communication: <ul style="list-style-type: none"> • Activate master or put it online • Reconfigure master • Connect correct module • Check slave address and correct if necessary
Green	Red flashing	Overload of sensor supply (slave is in RESET state and switches off completely)	Disconnect sensor cables from input sockets, install sensors with lower total current input, check sensors and cables
Green flashing	Red	Slave has address 0 (as-delivered state)	Address issued is not equal to 0
Green flashing (alternating flashing)	Red flashing	Overload of outputs (slave switches off all outputs)	Disconnect actuator cables from output sockets, check actuators and cables
Off	Off	No AS-i voltage, AS-i voltage with reversed polarity, AS-i voltage too low	Switch on AS-i voltage, connect correctly, measure AS-i voltage (approx. 30 V DC)

Note:

The display for LED FAULT is not labeled. It is located directly underneath the AS-i display LED. The status "overload of outputs" (green flashing/red flashing, alternating) is not displayed by all modules.

LED status displays for F90 modules

AS-i/FAULT	Possible cause	Possible remedy
Green	Normal operation; AS-Interface communication OK	--
Red	No AS-i communication: <ul style="list-style-type: none"> • Master deactivated or offline • Slave not configured in master • Wrong slave type connected • Slave has wrong address 	Ensure AS-i communication: <ul style="list-style-type: none"> • Activate master or put it online • Reconfigure master • Connect correct module • Check slave address and correct if necessary
Red flashing	Overload of sensor supply (slave is in RESET state and switches off completely)	Disconnect sensor cables from input sockets, install sensors with lower total current input, check sensors and cables
Yellow-red flashing	Slave has address 0 (as-delivered state)	Address issued is not equal to 0
Off	No AS-i voltage, AS-i voltage with reversed polarity, AS-i voltage too low	Switch on AS-i voltage, connect correctly, measure AS-i voltage (approx. 30 V DC)

Note:

F90 modules (16I) have no dual LED for AS-i/fault. Only "Green" and "Off" are displayed.

Additional LED status display for AUX POWER on modules with auxiliary voltage

AUX POWER	Possible cause	Possible remedy
Green	Normal operation; AS-Interface communication OK	--
Off	No auxiliary voltage Auxiliary voltage with reversed polarity Auxiliary voltage too low	Switch on 24 V DC auxiliary voltage, connect correctly, measure auxiliary voltage (approx. 24 V DC)

Note:

Modules without auxiliary voltage connection have no display LED for AUX POWER (e. g. pure input modules, modules with relay outputs). On SlimLine modules with width of 22.5 mm there is no display-LED for AUX POWER.

AS-Interface

Slaves

I/O modules for operation in the control cabinet, IP20

Overview

SlimLine modules of the S22.5 and S45 series

The AS-Interface series of modules for the "SlimLine" control cabinet with degree of protection IP20 creates space in the cabinet and in distributed local boxes.

For these modules the priority was placed on a narrow type of construction. They have a width of only 22.5 or 45 mm.

Standard sensors/actuators and the AS-Interface cable can be connected using removable screw-type or spring-type terminals.

Integrated adapters enable mounting onto a standard mounting rail. Disassembly from the standard mounting rail is quick and easy and requires no tools.

With an additional accessory (push-in lugs), the modules can also be screwed on.

All modules are fitted at the front with LEDs which indicate the module's status.

An addressing socket integrated at the front enables the module to be addressed also when it is installed.

In addition to the digital input/output modules there are modules of design S22.5 with special functions. These include:

- Counter module
- Ground-fault detection module

More information about these modules, see

- [Catalog LV 1 / chapter "Systems", section "AS-Interface" --> "Slaves"--> "Modules with Special Functions"](#)
- [In our Mall: section "Low-Voltage Controls / SIRIUS Industrial Controls / Systems" --> "AS-Interface" --> "Slaves" --> "Modules with Special Functions"](#)

The new AS-Interface specification 3.0 adds a number of completely new features to AS-Interface bus system. The extended address mode (A/B addresses) enables the connection of up to 62 slaves on one AS-Interface network. With the extended address mode according to specification 3.0, four outputs are now possible for the first time even with A/B slaves (instead of only three outputs possible up to now with specification 2.1). Hence with full expansion of an AS-Interface network, there are now 248 inputs as well as 248 outputs available on one AS-Interface system.

Modules with four inputs and four outputs as A/B slaves according to specification 3.0 are also available as SlimLine modules S45.

Note:

Please note that the modules according to Specification 3.0 can be used only with a new master according to AS-Interface Specification 3.0 (e. g. the new DP/AS-i LINK Advanced or IE/AS-i LINK PN IO) and that the cycle times for the outputs can extend to max. 20 ms.

Design

Removable terminals

The removable terminal is the innovative connection method by Siemens for AS-Interface SlimLine modules of the S22.5 and S45 series. This allows the complete terminal block to be quickly and easily assembled and disassembled. The connections do not have to be detached for this purpose.

Note:

Before the terminal blocks are removed, the unit must be de-energized.

Features

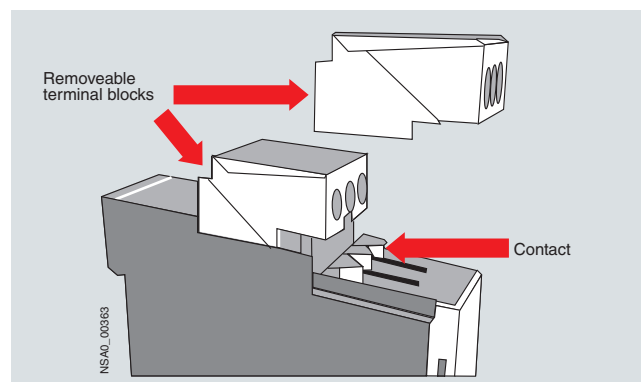

- **Service-proven terminal technology**
The new design of the removable terminal means that the conductors remain easy to connect. The old conductor cross-sections can still be used.
- **Variable connection methods**
All modules are available with screw-type and spring-type connections.
- **Coding**
The coding ensures that the terminal blocks cannot be mixed up (EN 50178).
- **Withdrawal and vibration safety**
The joint blocks are latched to the enclosure. The terminal blocks can be detached with the help of a IEC-4-41 screwdriver. The terminal blocks cannot be detached unintentionally.
- **Finger-safe**
The contacts are finger-safe according to DIN 61140 (IEC 60529) even if the unit is removed.
- **Inscription**
All terminal connections are printed onto the terminal block which allows the unit to be factory-fitted.

Unlocking the removable terminal

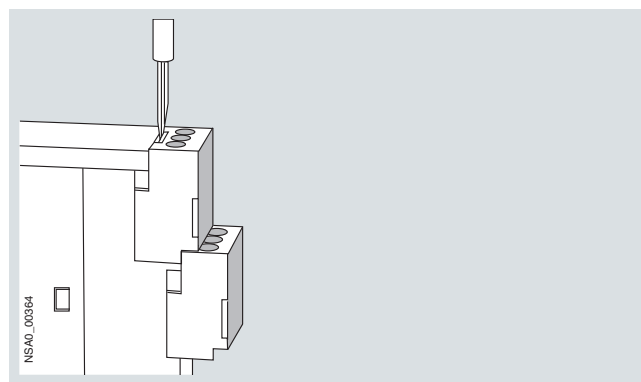

Step 1: release latch with screwdriver

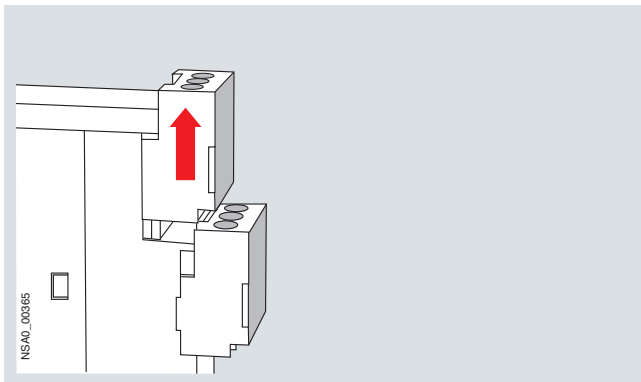

Step 2: pull terminal to the front

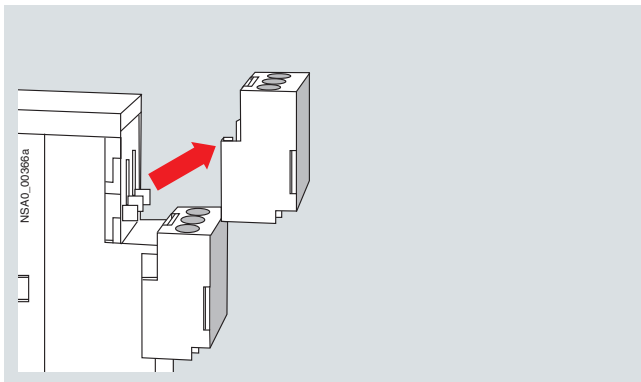

Step 3: lift terminal

Locking the removable terminal

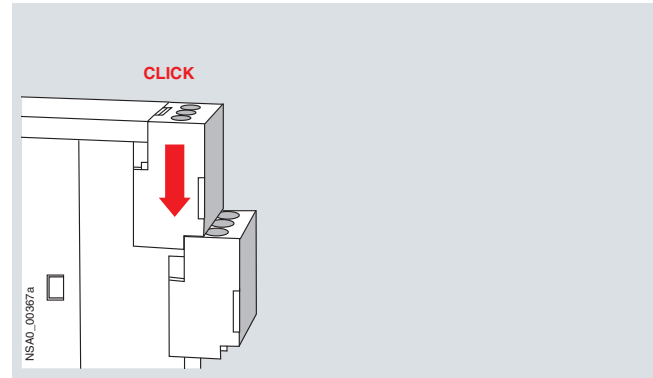

Push terminal to the back until it latches

Customer benefits

- Quick replacement of the basic unit minimizes maintenance costs and reduces downtimes
- The coding of the terminals prevents mistakes during replacement
- Configuration without unit possible
- Finger-safe during replacement
- Easy screw-type and spring-type connection

Technical specifications

Technical specifications common to all SlimLine modules

Operational voltage acc. to AS-Interface specification	V	26.5 ... 31.6
Input circuit		PNP
AS-Interface certificate		Yes (or requested for in case of new units)
Approvals		UL, CSA, shipbuilding (or requested for in case of new units)
Degree of protection		IP20
Ambient temperature	°C	-25 ... +70
Storage temperature	°C	-40 ... +85
Status displays		<ul style="list-style-type: none"> • Display of I/Os: Yellow LED • Display of AS-i: Green LED • Display of FAULT: Red LED
Note		An external additional supply (AUX POWER) of 20 to 30 V DC is required for the supply of the output circuits. The additional supply must comply with VDE 0106 (PELV), safety class III.

AS-Interface



Slaves

I/O modules for operation in the control cabinet,
IP20

SlimLine S22.5

		4 inputs		
		 Screw terminals		
		Standard slave 2-conductors 3RK1 200-0CE00-0AA2	Standard slave 2- and 3-conductors 3RK1 200-0CE02-0AA2	A/B slave 2- and 3-conductors 3RK2 200-0CE02-0AA2
Total current input	mA	≤ 50	≤ 270	≤ 270
Inputs				
• Sensor supply using AS-Interface		Short-circuit and overload resistant	Short-circuit and overload resistant	Short-circuit and overload resistant
• Voltage range	V	20 ... 30	20 ... 30	20 ... 30
• Current carrying capacity for sensor supply	mA	--	200	200
• Connection of sensors		2-conductor technology	2- and 3-conductor technology	2- and 3-conductor technology
• Switching level High	V	≥ 10	≥ 10	≥ 10
• Input current Low/High	mA	≤ 1.5/≥ 5	≤ 1.5/≥ 5	≤ 1.5/≥ 5
I/O configuration		0	0	0
ID/ID2 code		0/F	0/F	A/0
Assignment of data bits				
• Data bit D0		IN1	IN1	IN1
• Data bit D1		IN2	IN2	IN2
• Data bit D2		IN3	IN3	IN3
• Data bit D3		IN4	IN4	IN4
Connection		Using screw terminals	Using screw terminals	Using screw terminals



		4 inputs		4 inputs		
		 Spring-type terminals				
		Standard slave 2-conductors 3RK1 200-0CG00-0AA2	Standard slave 2- and 3-conductors 3RK1 200-0CG02-0AA2	A/B slave 2- and 3-conductors 3RK2 200-0CG02-0AA2		
Total current input	mA	≤ 50	≤ 270	≤ 270		
Inputs						
• Sensor supply using AS-Interface		Short-circuit and overload resistant	Short-circuit and overload resistant	Short-circuit and overload resistant		
• Voltage range	V	20 ... 30	20 ... 30	20 ... 30		
• Current carrying capacity for sensor supply	mA	--	200	200		
• Connection of sensors		2-conductor technology	2- and 3-conductor technology	2- and 3-conductor technology		
• Switching level High	V	≥ 10	≥ 10	≥ 10		
• Input current Low/High	mA	≤ 1.5/≥ 5	≤ 1.5/≥ 5	≤ 1.5/≥ 5		
I/O configuration		0	0	0		
ID/ID2 code		0/F	0/F	A/0		
Assignment of data bits						
• Data bit D0		IN1	IN1	IN1		
• Data bit D1		IN2	IN2	IN2		
• Data bit D2		IN3	IN3	IN3		
• Data bit D3		IN4	IN4	IN4		
Connection		Spring-type terminal	Spring-type terminal	Spring-type terminal		
Conductor cross-sections	mm ²	<ul style="list-style-type: none"> • Solid: 2 × (0.25 ...1.5) • Finely stranded with end sleeve: 2 × (0.25 ...1) • Finely stranded without end sleeve: 2 × (0.25 ...1.5) • AWG cables, solid or stranded: AWG 2 × (24 ...16) 	<ul style="list-style-type: none"> • Solid: 2 × (0.25 ...1.5) • Finely stranded with end sleeve: 2 × (0.25 ...1) • Finely stranded without end sleeve: 2 × (0.25 ...1.5) • AWG cables, solid or stranded: AWG 2 × (24 ...16) 	<ul style="list-style-type: none"> • Solid: 2 × (0.25 ...1.5) • Finely stranded with end sleeve: 2 × (0.25 ...1) • Finely stranded without end sleeve: 2 × (0.25 ...1.5) • AWG cables, solid or stranded: AWG 2 × (24 ...16) 		
Note	Detachment tool for spring-type terminal: see section "Accessories"					

		2 inputs/2 outputs		
		 Screw terminals		 Spring-type terminals
		Standard slave 2-conductors PNP transistor (2 A) 3RK1 400-0BE00-0AA2	Standard slave 2-conductors Relays 3RK1 402-0BE00-0AA2	Standard slave 2-conductors PNP transistor (2 A) 3RK1 400-0BG00-0AA2
Total current input	mA	≤ 50	≤ 50	≤ 50
Inputs				
• Sensor supply using AS-Interface		Short-circuit and overload resistant	Short-circuit and overload resistant	Short-circuit and overload resistant
• Voltage range	V	20 ... 30	20 ... 30	20 ... 30
• Current carrying capacity for sensor supply	mA	--	--	--
• Connection of sensors		2-conductor technology	2-conductor technology	2-conductor technology
• Switching level High	V	≥ 10	≥ 10	≥ 10
• Input current Low/High	mA	≤ 1.5/≥ 5	≤ 1.5/≥ 5	≤ 1.5/≥ 5
Outputs				
• Type of output		Transistor (PNP)	Relays	Transistor (PNP)
• Current carrying capacity per output DC 12/13 typical	A	2	--	2
• Maximum summation current per module	A	4	--	4
• Short-circuit protection		Built-in	External back-up fuse	Built-in
• Induction protection		Built-in	Does not apply	Built-in
• Reverse polarity protection		Not installed	Does not apply	Not installed
• External power supply 24 V DC		Using terminals: • Terminal 7: "+" • Terminal 10: "--"	Does not apply	Using terminals: • Terminal 7: "+" • Terminal 10: "--"
• I_{th}		--	6	--
• AC-15		--	3	--
• DC 13, 24 V		--	1	--
• DC 13, 110 V		--	0.2	--
• DC 13, 230 V		--	0.1	--
• Watchdog		Built-in	Built-in	Built-in
I/O configuration		3	3	3
ID/ID2 code		0/F	0/F	0/F
Assignment of data bits				
• Data bit D0		IN1	IN1	IN1
• Data bit D1		IN2	IN2	IN2
• Data bit D2		OUT1	OUT1	OUT1
• Data bit D3		OUT2	OUT2	OUT2
Connection		Screw terminals	Screw terminals	Spring-type terminal
Conductor cross-sections	mm ²	--	--	<ul style="list-style-type: none"> • Solid: 2 × (0.2 5...1.5) • Finely stranded with end sleeve: 2 × (0.25 ...1) • Finely stranded without end sleeve: 2 × (0.25 ...1.5) • AWG cables, solid or stranded: AWG 2 × (24 ...16)
Note		--	--	Detachment tool for spring-type terminal: see section "Accessories"

AS-Interface

Slaves

I/O modules for operation in the control cabinet,
IP20

		2 inputs/2 outputs	4 outputs	4 outputs
		 Spring-type terminals		 Spring-type terminals
		Standard slave 2-conductors Relays 3RK1 402-0BG00-0AA2	Standard slave -- PNP transistor (1 A) 3RK1 100-1CE00-0AA2	Standard slave -- PNP transistor (1 A) 3RK1 100-1CG00-0AA2
Total current input	mA	≤ 50	≤ 40	≤ 40
Inputs				
• Sensor supply using AS-Interface		Short-circuit and overload resistant	--	--
• Voltage range	V	20 ... 30	--	--
• Current carrying capacity for sensor supply	mA	--	--	--
• Connection of sensors		2-conductor technology	--	--
• Switching level High	V	≥ 10	--	--
• Input current Low/High	mA	≤ 1.5/≥ 5	--	--
Outputs				
• Type of output		Relay Changeover contact, floating	Solid state (PNP)	Solid state (PNP)
• Current carrying capacity per output DC 12/13 typical	A	--	1	1
• Maximum summation current per module	A	--	2	2
• Short-circuit protection		External back-up fuse required	Built-in	Built-in
• Induction protection		Does not apply	Built-in	Built-in
• Reverse polarity protection		Does not apply	Built-in	Built-in
• External power supply 24 V DC		Does not apply	Using screw terminals: • Terminal 7: "-" • Terminal 10: M	Using screw terminals: • Terminal 7: "-" • Terminal 10: M
• f_{th}		6	--	--
• AC-15		3	--	--
• DC 13, 24 V		1	--	--
• DC 13, 110 V		0.2	--	--
• DC 13, 230 V		0.1	--	--
• Watchdog		Built-in	Built-in	Built-in
I/O configuration		3	8	8
ID/ID2 code		0/F	0/F	0/F
Assignment of data bits				
• Data bit D0		IN1	OUT1	OUT1
• Data bit D1		IN2	OUT2	OUT2
• Data bit D2		OUT1	OUT3	OUT3
• Data bit D3		OUT2	OUT4	OUT4
Connection				
Conductor cross-sections	mm ²	Spring-type terminal	Screw terminals	Spring-type terminal
		<ul style="list-style-type: none"> • Solid: 2 × (0.25 ...1.5) • Finely stranded with end sleeve: 2 × (0.25 ...1) • Finely stranded without end sleeve: 2 × (0.25 ...1.5) • AWG cables, solid or stranded: AWG 2 × (24 ...16) 	--	<ul style="list-style-type: none"> • Solid: 2 × (0.25 ...1.5) • Finely stranded with end sleeve: 2 × (0.25 ...1) • Finely stranded without end sleeve: 2 × (0.25 ...1.5) • AWG cables, solid or stranded: AWG 2 × (24 ...16)
Note		Detachment tool for spring-type terminal: see section "Accessories"	--	Detachment tool for spring-type terminal: see section "Accessories"



SlimLine S45

		4 inputs/4 outputs		
		 Screw terminals		
		Standard slave		
		2- and 3-conductors PNP transistor (1 A) 3RK1 400-1CE00-0AA2	2- and 3-conductors PNP transistor (2 A) 3RK1 400-1CE01-0AA2	2- and 3-conductors (floating) PNP transistor (1 A) floating 3RK1 402-3CE01-0AA2
Total current input	mA	≤ 270	≤ 270	≤ 40
Inputs				
• Sensor supply using AS-Interface		Short-circuit and overload resistant	Short-circuit and overload resistant	Short-circuit and overload resistant
• Voltage range	V	20 ... 30	20 ... 30	20 ... 30
• Current carrying capacity for sensor supply	mA	200	200	200
• Connection of sensors		2- and 3-conductor technology	2- and 3-conductor technology	2- and 3-conductor technology
• Switching level High	V	≥ 10	≥ 10	≥ 10
• Input current Low/High	mA	≤ 1.5/≥ 5	≤ 1.5/≥ 5	≤ 1.5/≥ 5
Outputs				
• Type of output		Solid-state	Solid-state	Solid-state
• Current carrying capacity per output DC 12/13 typical	A	1	2	1
• Maximum summation current per module	A	4	4	4
• Short-circuit protection		Built-in	Built-in	Built-in
• Induction protection		Built-in	Built-in	Built-in
• Reverse polarity protection		Built-in	Built-in	Built-in
• External power supply 24 V DC		<ul style="list-style-type: none"> Terminal 13: L24+ Terminal 19: M24 	<ul style="list-style-type: none"> Terminal 13: L24+ Terminal 19: M24 	<ul style="list-style-type: none"> Sensor supply: <ul style="list-style-type: none"> Terminal 13: U_{s+} Terminal 19: U_{s-} Actuator supply: <ul style="list-style-type: none"> Terminal 14: L+ Terminal 20 to 24: M
• I _{th}		--	--	--
• AC-15		--	--	--
• DC 13, 24 V		--	--	--
• DC 13, 110 V		--	--	--
• DC 13, 230 V		--	--	--
• Watchdog		Built-in	Built-in	Built-in
I/O configuration		7	7	7
ID/ID2 code		0/F	0/F	0/F
Assignment of data bits				
• Data bit D0		IN1/OUT1	IN1/OUT1	IN1/OUT1
• Data bit D1		IN2/OUT2	IN2/OUT2	IN2/OUT2
• Data bit D2		IN3/OUT3	IN3/OUT3	IN3/OUT3
• Data bit D3		IN4/OUT4	IN4/OUT4	IN4/OUT4
Connection		Using screw terminals	Using screw terminals	Using screw terminals
Note		--	--	The module has four floating inputs and four floating switching outputs. An external additional supply of 20 to 30 V according to VDE 0106 (PELV) safety class III is required for the supply of the input and output circuits.

AS-Interface

Slaves

I/O modules for operation in the control cabinet,
IP20



		4 inputs/4 outputs		
		 Screw terminals	 Spring-type terminals	 Spring-type terminals
		Standard slave 2- and 3-conductors Relays 3RK1 402-3CE00-0AA2	Standard slave 2- and 3-conductors PNP transistor (1 A) 3RK1 400-1CG00-0AA2	Standard slave 2- and 3-conductors PNP transistor (2 A) 3RK1 400-1CG01-0AA2
Total current input	mA	≤ 270	≤ 270	≤ 270
Inputs				
• Sensor supply using AS-Interface		Short-circuit and overload resistant	Short-circuit and overload resistant	Short-circuit and overload resistant
• Voltage range	V	20 ... 30	20 ... 30	20 ... 30
• Current carrying capacity for sensor supply	mA	200	200	200
• Connection of sensors		2- and 3-conductor technology	2- and 3-conductor technology	2- and 3-conductor technology
• Switching level High	V	≥ 10	≥ 10	≥ 10
• Input current Low/High	mA	≤ 1.5/≥ 5	≤ 1.5/≥ 5	≤ 1.5/≥ 5
Outputs				
• Type of output		Relays	Solid-state	Solid-state
• Current carrying capacity per output DC 12/13 typical	A	--	1	2
• Maximum summation current per module	A	--	4	4
• Short-circuit protection		External back-up fuse 6 A gL/gG	Built-in	Built-in
• Induction protection		Does not apply	Built-in	Built-in
• Reverse polarity protection		--	Built-in	Built-in
• External power supply 24 V DC		Does not apply	• Terminal 13: L24+ • Terminal 19: M24	• Terminal 13: L24+ • Terminal 19: M24
• I_{th}		5	--	--
• AC-15		3	--	--
• DC 13, 24 V		1	--	--
• DC 13, 110 V		0.2	--	--
• DC 13, 230 V		0.1	--	--
• Watchdog		Built-in	Built-in	Built-in
• I/O configuration		7	7	7
ID/ID2 code		0/F	0/F	0/F
Assignment of data bits				
• Data bit D0		IN1/OUT1	IN1/OUT1	IN1/OUT1
• Data bit D1		IN2/OUT2	IN2/OUT2	IN2/OUT2
• Data bit D2		IN3/OUT3	IN3/OUT3	IN3/OUT3
• Data bit D3		IN4/OUT4	IN4/OUT4	IN4/OUT4
Connection		Using screw terminals	Spring-type terminal	Spring-type terminal
Conductor cross-sections		mm ²	--	--
			• Solid: 2 × (0.25 ...1.5) • Finely stranded with end sleeve: 2 × (0.25 ...1) • Finely stranded without end sleeve: 2 × (0.25 ...1.5) • AWG cables, solid or stranded: AWG 2 × (24 ...16)	• Solid: 2 × (0.25 ...1.5) • Finely stranded with end sleeve: 2 × (0.25 ...1) • Finely stranded without end sleeve: 2 × (0.25 ...1.5) • AWG cables, solid or stranded: AWG 2 × (24 ...16)
Note		--	Detachment tool for spring-type terminal: see section Accessories	



4 inputs/4 outputs			
 Spring-type terminals			
		Standard slave	
		2- and 3-conductors	
		PNP transistor (1 A)	Relays
		3RK1 402-3CG01-0AA2	3RK1 402-3CG00-0AA2
Total current input	mA	≤ 40	≤ 270
Inputs			
• Sensor supply using AS-Interface		Short-circuit and overload resistant	Short-circuit and overload resistant
• Voltage range	V	20 ... 30	20 ... 30
• Current carrying capacity for sensor supply	mA	200	200
• Connection of sensors		2- and 3-conductor technology	2- and 3-conductor technology
• Switching level High	V	≥ 10	≥ 10
• Input current Low/High	mA	≤ 1.5/≥ 5	≤ 1.5/≥ 5
Outputs			
• Type of output		Solid-state	Relays
• Current carrying capacity per output DC 12/13 typical	A	1	--
• Maximum summation current per A module	A	4	--
• Short-circuit protection		Built-in	External back-up fuse 6 A gL/gG
• Induction protection		Built-in	Does not apply
• Reverse polarity protection		Built-in	Built-in
• External power supply 24 V DC		Sensor supply:	Does not apply
		• Terminal 13: U _{s+}	
		• Terminal 19: U _{s-}	
		Actuator supply:	
		• Terminal 14: L+	
		• Terminal 20 to 24: M	
• I _{th}		--	5
• AC-15		--	3
• DC 13, 24 V		--	1
• DC 13, 110 V		--	0.2
• DC 13, 230 V		--	0.1
• Watchdog		Built-in	Built-in
I/O configuration		7	7
ID/ID2 code		0/F	0/F
Assignment of data bits			
• Data bit D0		IN1/OUT1	IN1/OUT1
• Data bit D1		IN2/OUT2	IN2/OUT2
• Data bit D2		IN3/OUT3	IN3/OUT3
• Data bit D3		IN4/OUT4	IN4/OUT4
Connection			
Conductor cross-sections	mm ²	Spring-type terminal	Spring-type terminal
		• Solid: 2 × (0.25 ... 1.5)	• Solid: 2 × (0.25 ... 1.5)
		• Finely stranded with end sleeve: 2 × (0.25 ... 1)	• Finely stranded with end sleeve: 2 × (0.25 ... 1)
		• Finely stranded without end sleeve: 2 × (0.25 ... 1.5)	• Finely stranded without end sleeve: 2 × (0.25 ... 1.5)
		• AWG cables, solid or stranded: AWG 2 × (24 ... 16)	• AWG cables, solid or stranded: AWG 2 × (24 ... 16)
Note 1		Detachment tool for spring-type terminal: see section "Accessories"	
Note 2		The module has four floating inputs and four floating switching outputs. An external additional supply of 20 to 30 V according to VDE 0106 (PELV) safety class III is required for the supply of the input and output circuits.	

AS-Interface

Slaves

I/O modules for operation in the control cabinet,
IP20

		4 inputs/3 outputs	
		 Screw terminals	 Spring-type terminals
		A/B slave 2- and 3-conductors PNP transistor (2 A) 3RK2 400-1FE00-0AA2	A/B slave 2- and 3-conductors PNP transistor (2 A) 3RK2 400-1FG00-0AA2
Total current input	mA	≤ 270	≤ 270
Inputs			
• Sensor supply using AS-Interface		Short-circuit and overload resistant	
• Voltage range	V	20 ... 30	20 ... 30
• Current carrying capacity for sensor supply	mA	200	200
• Connection of sensors		2- and 3-conductor technology	
• Switching level High	V	≥ 10	≥ 10
• Input current Low/High	mA	≤ 1.5/≥ 5	≤ 1.5/≥ 5
Outputs			
• Type of output		Solid-state	
• Current carrying capacity per output DC 12/13 typical	A	2	2
• Maximum summation current per module	A	4	4
• Short-circuit protection		Built-in	
• Induction protection		Built-in	
• Reverse polarity protection		Built-in	
• External power supply 24 V DC		<ul style="list-style-type: none"> Terminal 13: L24+ Terminal 19: M24 	
• f_{th}		--	--
• AC-15		--	--
• DC 13, 24 V		--	--
• DC 13, 110 V		--	--
• DC 13, 230 V		--	--
• Watchdog		Built-in	Built-in
I/O configuration		7	7
ID/ID2 code		A/0	A/0
Assignment of data bits			
• Data bit D0		IN1/OUT1	IN1/OUT1
• Data bit D1		IN2/OUT2	IN2/OUT2
• Data bit D2		IN3/OUT3	IN3/OUT3
• Data bit D3		IN4	IN4
Connection		Using screw terminals	Spring-type terminal
Conductor cross-sections	mm ²	--	<ul style="list-style-type: none"> Solid: 2 × (0.25...1.5) Finely stranded with end sleeve: 2 × (0.25...1) Finely stranded without end sleeve: 2 × (0.25...1.5) AWG cables, solid or stranded: AWG 2 × (24...16)
Note		--	Detachment tool for spring-type terminal: see section "Accessories"

		4 inputs/4 outputs	
		 Screw terminals	 Spring-type terminals
		A/B (Spec. 3.0) 2- and 3-conductors PNP transistor (2 A) 3RK2 400-1CE01-0AA2	A/B (Spec. 3.0) 2- and 3-conductors PNP transistor (2 A) 3RK2 400-1CG01-0AA2
Total current input	mA	≤ 270	≤ 270
Inputs			
• Sensor supply using AS-Interface		Short-circuit and overload resistant	Short-circuit and overload resistant
• Voltage range	V	20 ... 30	20 ... 30
• Current carrying capacity for sensor supply	mA	200	200
• Connection of sensors		2- and 3-conductor technology	2- and 3-conductor technology
• Switching level High	V	≥ 10	≥ 10
• Input current Low/High	mA	≤ 1.5/≥ 5	≤ 1.5/≥ 5
Outputs			
• Type of output		Solid-state	Solid-state
• Current carrying capacity per output DC 12/13 typical	A	2	2
• Maximum summation current per module	A	4	4
• Short-circuit protection		Built-in	Built-in
• Induction protection		Built-in	Built-in
• Reverse polarity protection		Built-in	Built-in
• External power supply 24 V DC		<ul style="list-style-type: none"> Terminal 13: L24+ Terminal 19: M24 	<ul style="list-style-type: none"> Terminal 13: L24+ Terminal 19: M24
• I_{th}		--	--
• AC-15		--	--
• DC 13, 24 V		--	--
• DC 13, 110 V		--	--
• DC 13, 230 V		--	--
• Watchdog		Built-in	Built-in
I/O configuration		7	7
ID/ID2 code		A/7	A/7
Assignment of data bits			
• Data bit D0		IN1/OUT1	IN1/OUT1
• Data bit D1		IN2/OUT2	IN2/OUT2
• Data bit D2		IN3/OUT3	IN3/OUT3
• Data bit D3		IN4/OUT4	IN4/OUT4
Connection		Using screw terminals	Spring-type terminal
Conductor cross-sections	mm ²	--	<ul style="list-style-type: none"> Solid: 2 × (0.25 ... 1.5) Finely stranded with end sleeve: 2 × (0.25 ... 1) Finely stranded without end sleeve: 2 × (0.25 ... 1.5) AWG cables, solid or stranded: AWG 2 × (24...16)
Note		--	Detachment tool for spring-type terminal: see section "Accessories"

AS-Interface

Slaves

I/O modules for operation in the control cabinet, IP20

Dimensional drawings

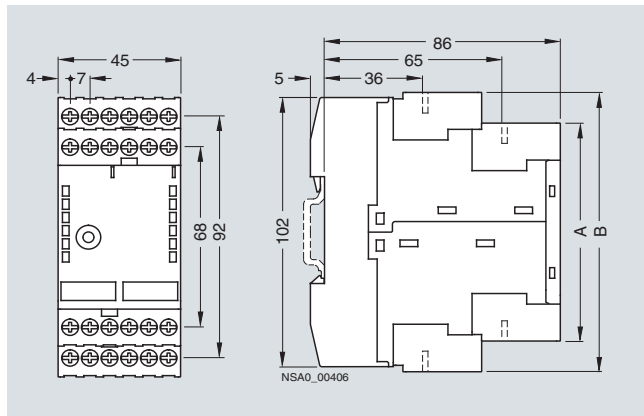

	A	B
Standard terminal		
Spring-type terminal	84,3	107,6
Screw terminal	81	104
Removeable terminal		
Spring-type terminal	84	108
Screw terminal	83	106

SlimLine S45

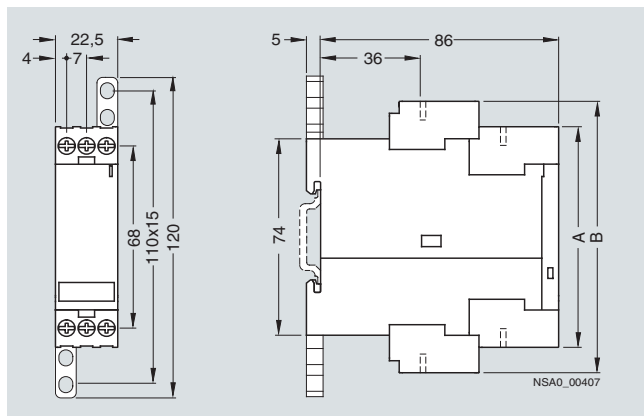

	A	B
Standard terminal		
Spring-type terminal	81,6	101,6
Screw terminal	80	100
Removeable terminal		
Spring-type terminal	84	103
Screw terminal	83	102

SlimLine S22.5

Schematics

Switching example for SlimLine S22.5

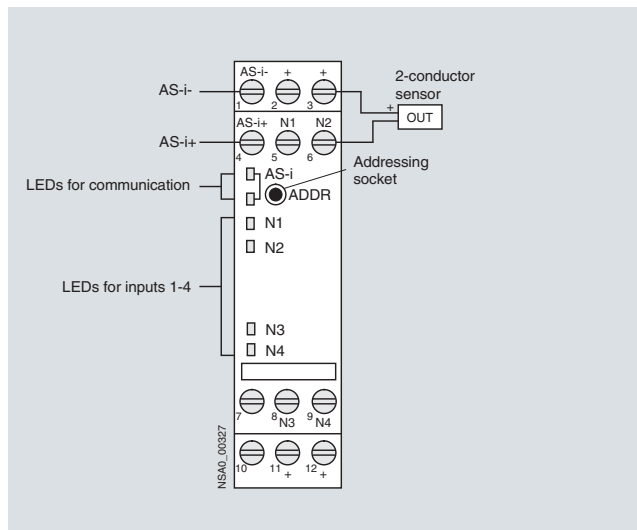

3RK1 200-0CE00-0AA2

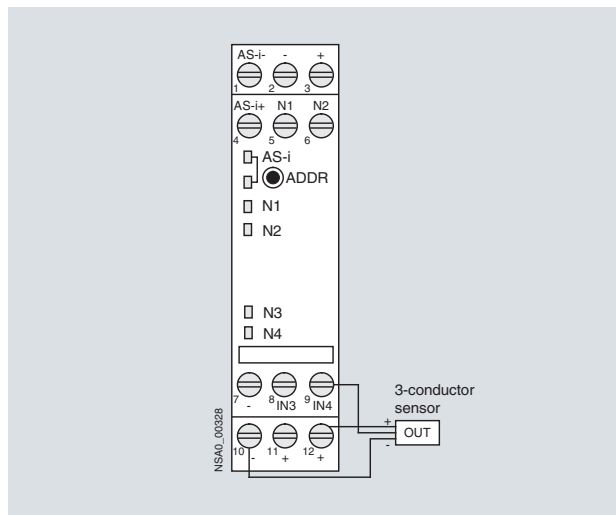

3RK1 200-0CE02-0AA2

Switching example for SlimLine S45

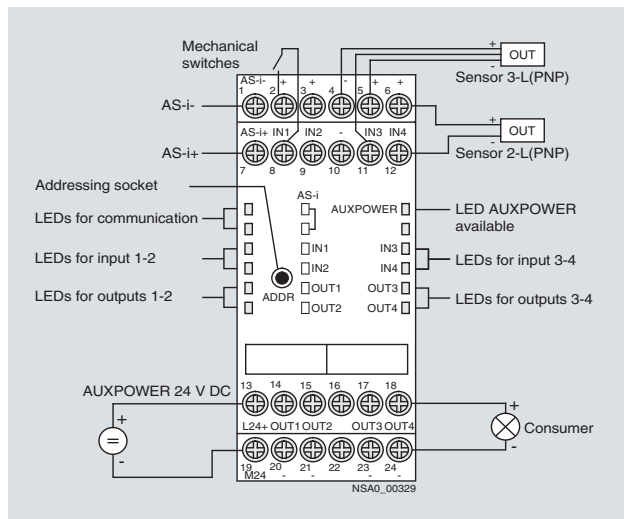

Function

Mode of operation of the 16I module (3RG9 002-0DE00 and 3RG9 004-0DE00)

The 16 inputs are organized in four groups of four inputs each.

Only one group is allowed to be activated at a time. The PLC activates each group one after the other and reads the four items of input information from each group into the process image of the inputs (PAE). The user program assigns the items of input information to the respective groups, i. e. the output image (PAA) of the PLC must match the set output of the module or items of input information would otherwise be read by a wrong group.

With disrupted AS-Interface transmission it can take three AS-Interface cycles (15 ms) for the output image (AA) of the slave to match the output image of the master and hence that of the PLC. Similarly it can take three AS-Interface cycles to transmit the input image of the slave. If message frames on the particular slave are disrupted for more than three successive AS-Interface cycles, a "Config Error" results on the master. The input image in the master is set to "Zero" and the error bit is set in the PLC.

Example: Behavior of the AA and EA in the master and in the slave when the AS-Interface transmission is disrupted

AS-Interface-cycle	PLC		Master		Module		Note
	PAA	PAE	AA	EA	AA	EA	
	1000	xxxx					
1	1000	xxxx	0111	xxxx	xxxx	xxxx	fault in MC or SR
2	1000	xxxx	0111	xxxx	xxxx	xxxx	fault in MC or SR
3	1000	xxxx	0111	EEEE	1000	EEEE	E invalid because of switchover time in module
4	1000	xxxx	0111	xxxx	1000	EEEE	fault in MC or SR
5	1000	xxxx	0111	xxxx	1000	EEEE	fault in MC or SR
6	1000	xxxx	0111	EEEE	1000	EEEE	no fault in MC or SR
	1000	EEEE	0111				

NSA0_00321

Legend:

- AA Output image
- EA Input image
- MC Master call
- PAA Process image of the outputs
- PAE Process image of the inputs
- SR Slave response
- PLC Programmable logic controller

The example shows that the AA and EA in the master and in the slave do not match each other until after six AS-Interface cycles. The PLC cycle is asynchronous in relation to the AS-Interface cycle. Hence the time it takes the AA and EA from the master and the PLC to match each other is increased by one AS-Interface cycle and one PLC cycle.

Equation for the cycle time:
 $4 \times ((6 \times 5 \text{ ms}) + 5 \text{ ms} + 10 \text{ ms}) = 180 \text{ ms}$

Function blocks

The following function blocks (FB) are available for the sequence control:

- FC 22 for S7-300

The time between two calls of the FB for a module must amount to at least 30 ms in order for the switching states of the inputs to be read in reliably.

Programming examples:

Programming examples for the S7-300 are available from Technical Assistance, Tel. +49 (0)911 895-5900 or the Internet.

More information

You can find further information on the Internet at:





<http://www.siemens.com/as-interface>



AS-Interface

Slaves

I/O modules for operation in the control cabinet,
IP20

Technical specifications



		4 inputs/4 outputs			
		1 A	2 A	1 A	2 A
		 Screw terminals	 Screw terminals	 Combicon connectors	 Combicon connectors
		3RG9 002-0DB00	3RG9 002-0DA00	3RG9 004-0DB00	3RG9 004-0DA00
Slave type		Standard slave			
Operational voltage acc. to AS-Interface specification	V	26.5 ... 31.6			
Total current input	mA	≤ 270			
Input circuit		PNP			
Inputs					
• Sensor supply using AS-Interface		Short-circuit and overload resistant			
• Voltage range	V	20 ... 30			
• Current carrying capacity for sensor supply	mA	200			
• Connection of sensors		2- and 3-conductor technology			
• Switching level High	V	≥ 10			
• Input current Low/High	mA	≤ 1.5/≥ 5			
Outputs					
• Type of output		Solid-state			
• Current carrying capacity in A DC-12/ DC-13 typical		1	2	1	2
• Total current of all outputs	A	4	6	4	6
• Short-circuit protection		Built-in			
• Induction protection		Built-in			
• External power supply 24 V DC		Built-in using screw terminals		Built-in using Combicon plug connector	
• Watchdog		Built-in			
I/O configuration		7			
ID/ID2 code		0/F			
Assignment of data bits					
• Data bit D0		IN1/OUT1			
• Data bit D1		IN2/OUT2			
• Data bit D2		IN3/OUT3			
• Data bit D3		IN4/OUT4			
AS-Interface certificate		Yes			
Approvals		UL, CSA, shipbuilding			
Degree of protection		IP20			
Ambient temperature	°C	-25 ... +70			
Storage temperature	°C	-40 ... +85			
Displays					
• Inputs/outputs		Yellow LEDs			
• AS-i voltage		Green LED			
Connection		Using screw terminals		Using Combicon plug connector	
Addressing procedure		Possible using integrated addressing socket			
Note		An external additional supply (AUX POWER) of 20 to 30 V DC is required for the supply of the output circuits. The additional supply must comply with VDE 0106 (PELV), safety class III.			

		4 inputs/4 outputs	
		2 A, floating	
		 Screw terminals	 Combicon connectors
		3RG9 002-0DC00	3RG9 004-0DC00
Slave type		Standard slave	
Operational voltage acc. to AS-Interface specification	V	26.5 ... 31.6	
Total current input	mA	≤ 30	
Input circuit		PNP	
Inputs			
• Sensor supply using AS-Interface			
Short-circuit and overload resistant			
• Voltage range	V	20 ... 30	
• Current carrying capacity for all inputs	mA	200	
• Connection of sensors		2- and 3-conductor technology	
• Switching level High in V	V	≥ 10	
• Input current Low/High	mA	≤ 1.5/≥ 5	
Outputs			
• Type of output			
Solid-state			
• Current carrying capacity in A DC-12/ DC-13 typical			
2			
• Total current of all outputs	A	6	
• Short-circuit protection			
Built-in			
• Induction protection			
Built-in			
• External power supply 24 V DC			
		Using screw terminals	Using Combicon plug connector
• Watchdog			
Built-in			
I/O configuration		7	
ID/ID2 code		0/F	
Assignment of data bits			
• Data bit D0			
IN1/OUT1			
• Data bit D1			
IN2/OUT2			
• Data bit D2			
IN3/OUT3			
• Data bit D3			
IN4/OUT4			
AS-Interface certificate		Yes	
Approvals		UL, CSA, shipbuilding	
Degree of protection		IP20	
Ambient temperature	°C	-25 ... +70	
Storage temperature	°C	-40 ... +85	
Displays			
• Inputs/outputs			
Yellow LED			
• AS-i voltage			
Green LED			
Connection		Using screw terminals	Using Combicon plug connector
Addressing procedure		Possible using integrated addressing socket	
Note 1		The module has four floating inputs and four floating switching outputs. An external additional supply of 20 to 30 V DC according to VDE 0106 (PELV) safety class III is required for the supply of the input and output circuits.	
Note 2		An external additional supply (AUX POWER) of 20 to 30 V DC is required for the supply of the output circuits. The additional supply must comply with VDE 0106 (PELV), safety class III.	

AS-Interface

Slaves

I/O modules for operation in the control cabinet,
IP20

		16 inputs	
		 Screw terminals PNP transistor 3RG9 002-0DE00	 Combicon connectors PNP transistor 3RG9 004-0DE00
Slave type		Standard slave	
Operational voltage acc. to AS-Interface specification	V	26.5 ... 31.6	
Total current input	mA	≤ 70	
Input circuit		PNP	
Inputs		Short-circuit and overload resistant	
• Sensor supply using AS-Interface			
• Voltage range	V	20 ... 30	
• Connection of sensors		Mechanical contacts	
• Signal 1 U_{in}		20 ... 30 V ≥ 3 mA	
Group signal			
• Current carrying capacity I_{out}	mA	≤ 25	
• Output voltage U_{out}	V	20 ... 30	
Watchdog		Built-in	
I/O configuration		7	
ID/ID2 code		F/F	
Assignment of data bits			
• Data bit D0		Group signal G1 (D0) inputs I 1.1 to I 1.4 (D0 to D3)	
• Data bit D1		Group signal G2 (D1) inputs I 2.1 to I 2.4 (D0 to D3)	
• Data bit D2		Group signal G3 (D2) inputs I 3.1 to I 3.4 (D0 to D3)	
• Data bit D3		Group signal G4 (D3) inputs I 4.1 to I 4.4 (D0 to D3)	
AS-Interface certificate		Yes	
Approvals		UL, CSA, shipbuilding	
Degree of protection		IP20	
Ambient temperature	°C	-25 ... +70	
Storage temperature	°C	-40 ... +85	
Displays of inputs/outputs		Yellow LED	
Connection		Using screw terminals	Using Combicon plug connector
Addressing procedure		Possible using integrated addressing socket	
Note 1		The module has four input groups. Each input group has four inputs and a group signal for the power supply of the inputs. The input groups are activated individually by setting of the respective group signal by the control system. The switching states of the assigned inputs are then read in.	
Note 2		Function block required	
Note 3		An external additional supply (AUX POWER) of 20 to 30 V DC is required for the supply of the output circuits. The additional supply must comply with VDE 0106 (PELV), safety class III.	

Dimensional drawings

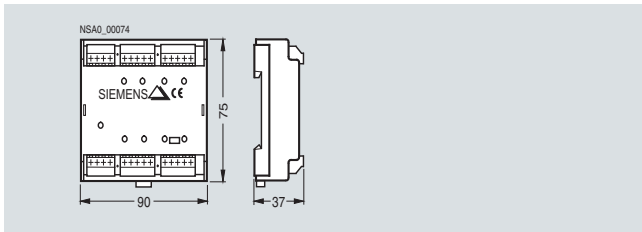

Schematics

Terminal assignment

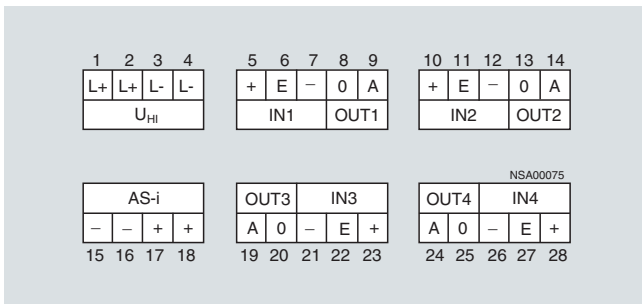

3RG9 002-0D.00
3RG9 004-0D.00

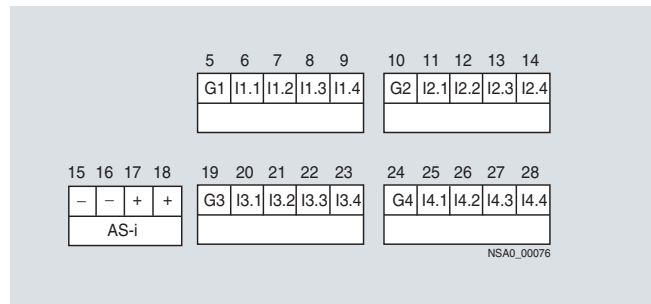

3RG9 002-0DE00
3RG9 004-0DE00

AS-Interface

Slaves

I/O modules for operation in the control cabinet,
IP20

Technical specifications

		Flat modules 4 inputs/4 outputs 200 mA for all I/Os
		 Screw terminals
		3RK1 400-0CE00-0AA3
Slave type		Standard slave
Operational voltage acc. to AS-Interface specification	V	26.5 ... 31.6
Total current input	mA	≤ 270 ¹⁾
Input circuit		PNP
Inputs		
• Sensor supply using AS-Interface		Short-circuit and overload resistant
• Voltage range	V	20 ... 30
• Current carrying capacity for all inputs	mA	200 ¹⁾
• Connection of sensors		2- and 3-conductor technology
• Switching level High	V	≥ 10
• Input current Low/High	mA	≤ 1.5/≥ 5
Outputs		
• Type of output		Solid-state
• Current carrying capacity (DC 12/DC 13)	mA	200 ¹⁾
• Short-circuit protection		Built-in
• Induction protection		Built-in
• External power supply 24 V DC		Not required (supply of all inputs and outputs using AS-Interface cable)
Watchdog		Built-in
I/O configuration		7
ID/ID2 code		F/F
Assignment of data bits		
• Data bit D0		IN1/OUT1
• Data bit D1		IN2/OUT2
• Data bit D2		IN3/OUT3
• Data bit D3		IN4/OUT4
AS-Interface certificate		Yes
Degree of protection		IP20
Ambient temperature	°C	-25 ... +85
Storage temperature	°C	-40 ... +85
Displays of inputs/outputs		
• AS-i voltage		Green LED
• FAULT		Red LED
Connection		Using screw terminals
Addressing procedure		Using integrated addressing socket

¹⁾ Summation current for all inputs and outputs max. 200 mA.

Dimensional drawings

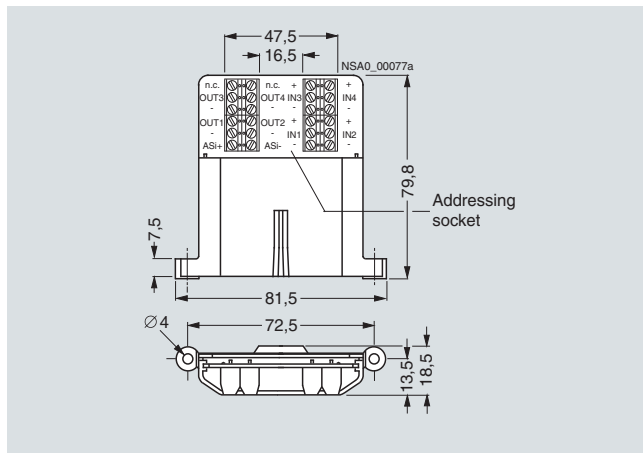

Overview

3RK1 400-0CD00-0AA3 AS-Interface communication module for printed circuit board installation

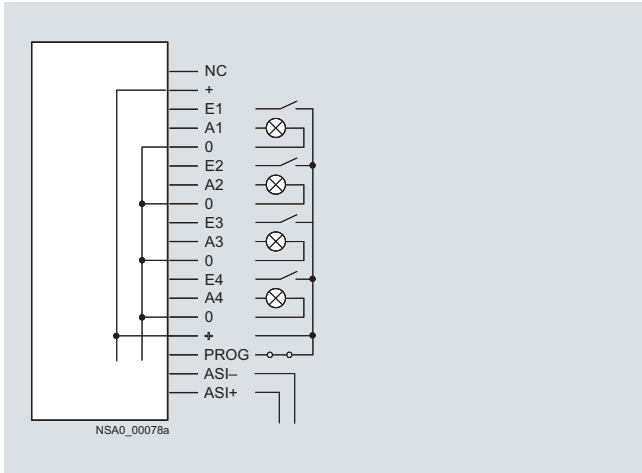

With the 4I/4O module for printed circuit board mounting it is possible for up to four mechanical contacts to be queried or indicator lights to be operated, the necessary energy being provided by the AS-Interface system (yellow AS-Interface cable).

Note:

If the switching outputs are overloaded, the module does not respond to invoking by a master.

3RK1 400-0CD01-0AA3 AS-Interface communication module for printed circuit board installation

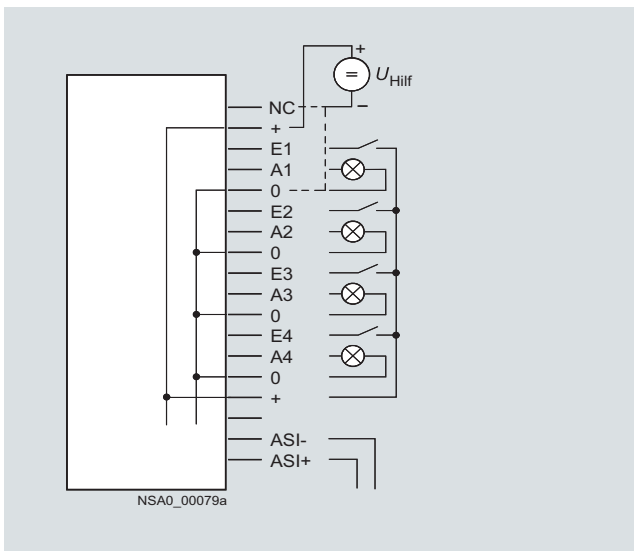

With the 4I/4O module for printed circuit board mounting it is possible for up to four mechanical contacts to be queried or indicator lights to be operated, the necessary energy for the inputs and outputs being provided from the auxiliary voltage (24 V PELV). If (+) is connected to $U_{aux} +$ and (NC) to $U_{aux} -$, the outputs are *not* short-circuit and overload resistant; if $U_{aux} -$ is connected to (0), the outputs are overload and short-circuit resistant (maximum summation current 200 mA). In this case the module does not respond even to invoking by a master when the switching outputs are overloaded.

3RG9 005-0SA00 AS-Interface communication module for printed circuit board installation

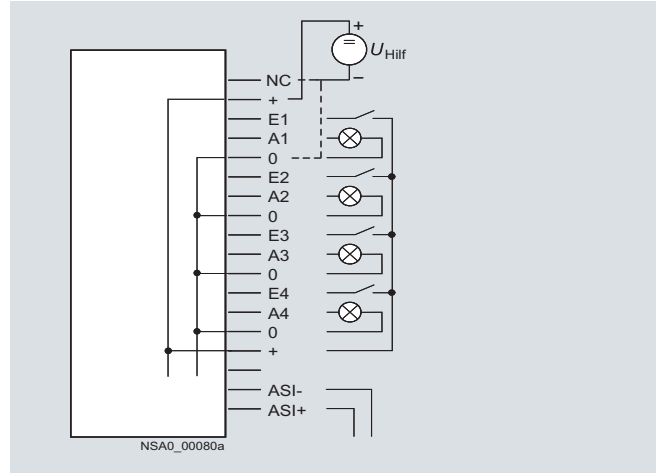

With the 4I/4O module for printed circuit board mounting it is possible for up to four mechanical contacts to be queried or indicator lights to be operated, the power for inputs and outputs being provided from an auxiliary voltage (24 V PELV). If (+) is connected to $U_{aux} +$ and (NC) to $U_{aux} -$, the outputs are *not* short-circuit and overload resistant; if $U_{aux} -$ is connected to (0), the outputs are overload and short-circuit resistant (maximum summation current 200 mA). In this case the module does not respond even to invoking by a master when the switching outputs are overloaded.

AS-Interface

Slaves

Special integrated solutions AS-Interface communication modules

3RK1 400-1CD00-0AA2, 3RK2 400-1FD00-0AA2 AS-Interface communication module for printed circuit board installation

Connection	Connection pad ¹⁾
AS-i +	27, 29
AS-i -	28, 30
Sensor+	17, 18, 23, 24
Sensor-	13, 14, 19, 20
IN1	21
IN2	22
IN3	15
IN4	16
U_{aux+} (L24+)	2, 4
U_{aux-} (M24)	1, 3
OUT1	9
OUT2	10
OUT3	5
OUT4	6 (not assigned for 3RK2 400-1FD00-0AA2 4I/3O module)
OUT-	7, 8
Not assigned	11, 12, 25, 26

¹⁾ Pad numbering, see section "Dimensional drawings".

With the 4I/4O or 4I/3O module for printed circuit board mounting it is possible for up to four mechanical contacts or 3-conductor sensors according to IEC 947-5-2 to be connected.

Up to four indicator lights via the 4I/4O module or up to three indicator lights via the 4I/3O module can also be controlled. The power for short-circuit resistant solid-state switching outputs is provided from an auxiliary voltage (24 V PELV).

Mounting is very easy using a "Card Edge Board-to-Board-Connector". This connector can be ordered for vertical and horizontal mounting from the company AMP, for example:

- 180° version for vertical mounting (AMP): Order No. 530843-2
- 90° version for horizontal mounting (AMP): Order No. 650118-1

If the inputs are loaded with more than 200 mA, the module does not respond to invoking by a master.

3RK1 200-0CD00-0AA2 AS-Interface communication module for printed circuit board installation

Connection	Connection pad ¹⁾
AS-i +	27, 29
AS-i -	28, 30
Sensor+	17, 18, 23, 24
Sensor-	13, 14, 19, 20
IN1	21
IN2	22
IN3	15
IN4	16
Not assigned	1, 2, 3, 4, 5, 6, 7, 8, 9, 10, 11, 12, 25, 26

¹⁾ Pad numbering, see section "Dimensional drawings".

With the 4I module for printed circuit board mounting it is possible for up to four mechanical contacts or 3-conductor sensors to be connected, the power for inputs being provided from AS-Interface cable.

Mounting is very easy using a "Card Edge Board-to-Board-Connector". This connector can be ordered for vertical and horizontal mounting from the company AMP, for example:

- 180° version for vertical mounting (AMP): Order No. 530843-2
- 90° version for horizontal mounting (AMP): Order No. 650118-1

If the inputs are loaded with more than 200 mA, the module does not respond to invoking by a master.

Technical specifications

		4 inputs/ 4 outputs	4 inputs/ 4 outputs	4 inputs/ 4 outputs	4 inputs/ 4 outputs	4 inputs/ 3 outputs	4 inputs
		3RK1 400-0CD00-0AA3	3RK1 400-0CD01-0AA3	3RG9 005-0SA00	3RK1 400-1CD00-0AA2	3RK2 400-1FD00-0AA2	3RK1 200-0CD00-0AA2
Supply		Supply of I/Os using AS-Interface cable (max. 200 mA)	Supply of I/Os using external auxiliary voltage (24 V PELV)	Supply of I/Os using external auxiliary voltage (24 V PELV)	Supply of outputs using external auxiliary voltage (24 V PELV)	Supply of outputs using external auxiliary voltage (24 V PELV)	--
Version		Printed circuit board with solder pins, protected by enclosure	Printed circuit board with solder pins, protected by enclosure	Printed circuit board with solder pins for horizontal mounting	Printed circuit board with gold-plated direct connector for 30-pole male connector socket for simple installation with direct connector		
Slave type		Standard slave	Standard slave	Standard slave	Standard slave	Standard slave	Standard slave
Operational voltage acc. to AS-Interface specification	V	26.5 ... 31.6	26.5 ... 31.6	26.5 ... 31.6	26.5 ... 31.6	26.5 ... 31.6	26.5 ... 31.6
Total current input	mA	≤ 270	≤ 25	≤ 25	≤ 270	≤ 270	≤ 270
Input circuit		PNP	PNP	PNP	PNP	PNP	PNP
Inputs							
• Sensor supply		Using AS-Interface	Using U_{aux}	Using U_{aux}	Using AS-Interface cable	Using AS-Interface cable	Using AS-Interface cable
• Switching voltage	V	20 ... 30	20 ... 30	20 ... 30	20 ... 30	20 ... 30	20 ... 30
• Switching current	mA	≥ 3	≥ 3	≥ 3	--	--	--
Outputs							
• Type of output		Solid-state	Solid-state	Solid-state	Solid-state	Solid-state	--
• Load voltage	V	20 ... 30	19 ... 30	19 ... 30	$U_{aux} - 0.8 V$	$U_{aux} - 0.8 V$	--
• Short-circuit protection		Built-in	Built-in	Built-in	Built-in	Built-in	--
• Induction protection		--	--	--	Built-in (freewheel diode)	Built-in (freewheel diode)	--
• External power supply 24 V DC		Using solder pins	Using solder pins	Using solder pins	Using printed circuit board contacts	Using printed circuit board contacts	--
Summation current for all inputs and outputs	mA	200	200	200	200	200	200
I/O configuration		7	7	7	7	7	0
ID/ID2 code		0/F	0/F	0/F	0/F	I/O	0/F
Assignment of data bits							
• Data bit D0		IN1/OUT1	IN1/OUT1	IN1/OUT1	IN1/OUT1	IN1/OUT1	IN1
• Data bit D1		IN2/OUT2	IN2/OUT2	IN2/OUT2	IN2/OUT2	IN2/OUT2	IN2
• Data bit D2		IN3/OUT3	IN3/OUT3	IN3/OUT3	IN3/OUT3	IN3/OUT3	IN3
• Data bit D3		IN4/OUT4	IN4/OUT4	IN4/OUT4	IN4/OUT4	IN4/--	IN4
Approvals		UL, CSA, shipbuilding	UL, CSA, shipbuilding	UL, CSA, shipbuilding	--	--	--
Degree of protection		IP20 enclosure connecting pins IP00	IP20 enclosure connecting pins IP00	IP00	IP00	IP00	IP00
Ambient temperature	°C	-25 ... +70	-25 ... +70	-25 ... +70	-25 ... +70	-25 ... +70	-25 ... +70
Storage temperature	°C	-40 ... +80	-40 ... +80	-40 ... +80	-40 ... +85	-40 ... +85	-40 ... +85
Display		None	None	None	AS-i: Green Fault: Red I/O: Yellow L24+: Green	AS-i: Green Fault: Red I/O: Yellow L24+: Green	AS-i: Green Fault: Red Inputs: Yellow
LED status display		--	--	--	<ul style="list-style-type: none"> • <u>AS-i:</u> On On Flashes On • <u>Fault:</u> Off On On Flashes • <u>Status:</u> OK No data traffic Zero address Overload (sensor) 		

AS-Interface

Slaves

Special integrated solutions
AS-Interface communication modules

Dimensional drawings

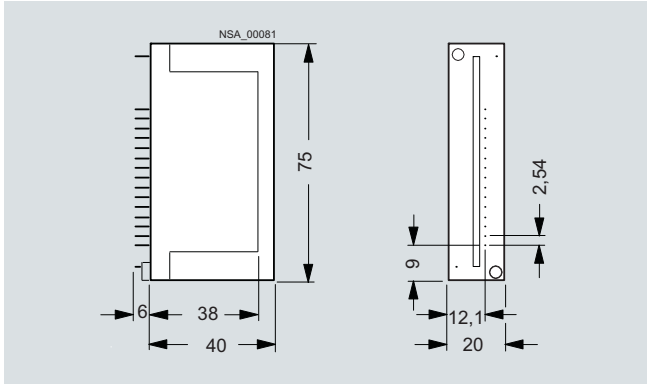

3RK1 400-0CD00-0AA3
3RK1 400-0CD01-0AA3

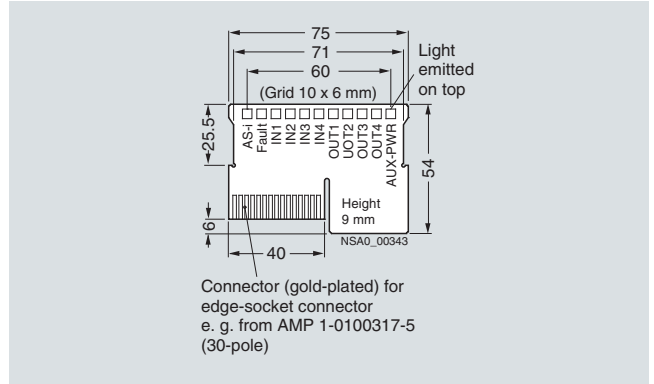

3RK2 400-1FD00-0AA2
3RK1 400-1CD00-0AA2
3RK1 200-0CD00-0AA2

Pad numbering on front: 29, 27, 25, ..., 5, 3, 1
Pad numbering on rear: 30, 28, 26, ..., 6, 4, 2

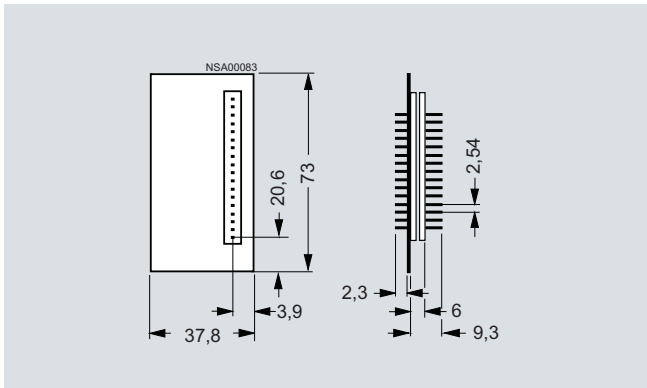

3RG9 005-0SA00

Overview

This module is used to send hexadecimally coded count values (LSB=D0, MSB=D3) to a higher-level controller. The count value is increased by one for each valid count pulse at terminal 8. Beginning at 0, the module counts up to 15 and then begins again at 0. The controller adopts the current value and determines the number of pulses between two host invocations through subtraction from the previous value. The total number of count pulses is determined by adding these differences.

For the values sent to be unambiguous, no more than 15 count values are allowed between two host invocations or AS-Interface master invocations at terminal 8. The maximum permissible transmission frequency is calculated from these times:

$$f_{T_{max}} = 15/T_{max}$$

T_{max} : max. possible transmission time from the slave to the host

Another condition for the maximum frequency is the pulse shaped required. For the counter to accept a pulse as valid, a Low must have been applied at the input for at least 300 μ s and a High for at least 1 ms. This results in a controller-independent maximum frequency of

$$f_{C_{max}} = 1/1.3 \text{ ms} = 769 \text{ Hz}$$

for the counter module (see following graphic).

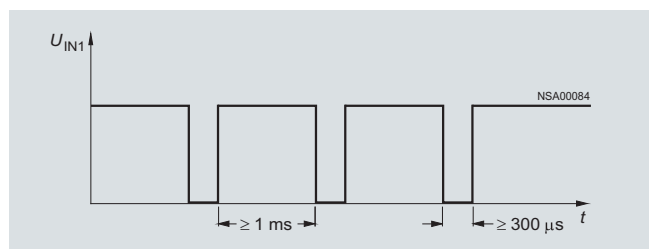

Time criteria for counter module

If the time criterion stipulated in the graphic is violated, the count value is rejected.

The counter is active only for the reset parameter P2 (default). The counter is deleted when P2 is set, and the incoming count pulses are not registered until after P2 is reset again.

Note:

A customized function block is necessary or must be programmed.

Programming examples for the S7-300 are available from Technical Assistance, Tel. +49 (0)911 895-5900 or the Internet.

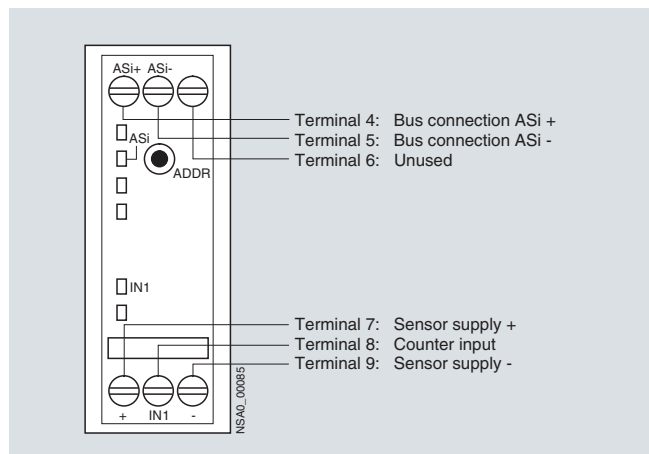

Connection options

Technical specifications

		Counter modules	
		With screw terminal connection	With spring-type terminal
		3RK1 200-0CE03-0AA2	3RK1 200-0CG03-0AA2
Slave type		Standard slave	
Operational voltage acc. to AS-Interface specification	V	26.5 ... 31.6	
Total current input	mA	≤ 170	
Input		Short-circuit and overload resistant	
• Sensor supply using AS-Interface		Terminal 7: + Terminal 9: - Terminal 8: IN1	
• Assignment			
• Voltage range	V	20 ... 30	
• Current carrying capacity	mA	90	
• Switching level Low/High	V	≤ 5/≥ 10	
• Input current Low/High	mA	≤ 2/≥ 10	
I/O configuration		0	
ID code		F	
AS-Interface certificate		Yes	
Approvals		UL, CSA, shipbuilding	
Degree of protection		IP20	
Ambient temperature	°C	-25 ... +70	
Storage temperature	°C	-40 ... +85	
Displays		AS-i	
• AS-i		LED green on + LED red off = Status OK LED green off + LED red on = no data traffic LED green flashes + LED red on = zero address LED green off + LED red flashes = overload (sensor)	
Conductor cross-sections	mm ²		
• Solid	--		2 × (0.25–1.5)
• Finely stranded with end sleeve	--		2 × (0.25–1)
• Finely stranded without end sleeve	--		2 × (0.25–1.5)
• AWG cables, solid or stranded	--		AWG 2 × (24–16)

AS-Interface

Slaves

Modules with special functions Ground-fault detection modules

Overview

"... Ground faults in control circuits must not result in a machine's unintentional starting or hazardous movements, nor must they prevent it from stopping (EN 60204, Part 1)."

The AS-Interface ground-fault detection module is used to meet these requirements. Using this module from the SlimLine series, ground faults in AS-Interface systems can be reliably detected and reported.

The following ground faults are detected:

- Ground fault from AS-i +
- Ground fault from AS-i -
- Ground fault from sensors and actuators which are supplied from the AS-Interface voltage.

One module per AS-Interface network is required.

Function

A ground fault is detected by the module, is indicated by an LED and is signaled by two signaling outputs (1st: OK, 2nd: Fault). The ground fault signal is stored in the module. The ground fault must first be eliminated in order to be able to reset the module by switching off the the AS-Interface voltage, by using a reset button or by applying a High level to the floating remote reset input. The reset button can also be used for function checking.

External auxiliary voltages are not monitored for ground faults with this module.

Note:

The ground-fault detection module is a passive module without IC and as such does not need its own address on the AS-Interface network.

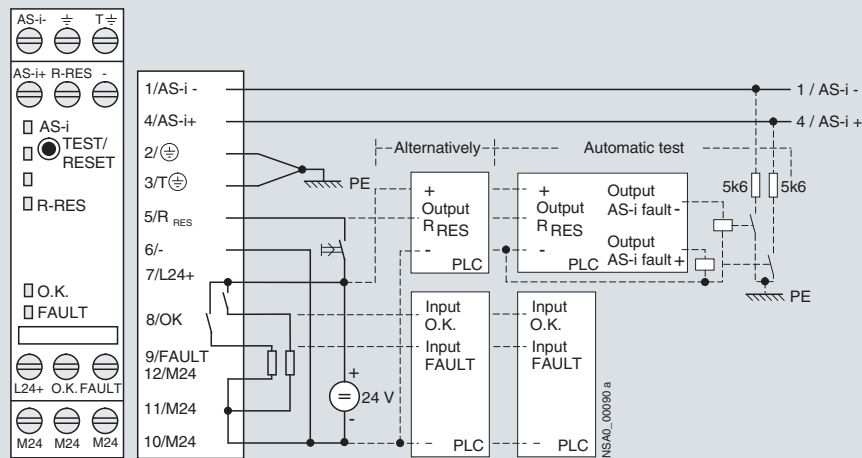

Terminal	Designation
1	AS-i - connection
2	Connection for system earth
3	Connection for system earth (for test function)
4	AS-i + connection
5	Remote reset input (R-RES)
6	Remote reset ground (-)
7	External voltage supply for signaling outputs L24+
8	Signaling output OK
9	Signaling output FAULT (earth fault signaling)
10	External voltage supply for signaling outputs M24
11	Negative connection for signaling output M24
12	Negative connection for signaling output M24

Connection options

Technical specifications

		Ground-fault detection modules	
		With screw terminal	With spring-type terminal
		3RK1 408-8KE00-0AA2	3RK1 408-8KG00-0AA2
Total current input	mA	≤ 40	
Reverse polarity protection		Built-in	
Ground fault		10 % $U_{AS-i} \leq U_{GND} \leq 90 \% U_{AS-i}$	
Low signal range			
• I_{IN}	mA	≤ 1.5	
High signal range			
• U_{IN}	V	≥ 10	
• I_{IN}	mA	≥ 6	
Current carrying capacity¹⁾			
• DC 12	A	1 (max. 2 per module)	
• DC 13	A	500 (24 V) ²⁾	
• DC 13	mA	200 (48 V) ²⁾	
Operating cycles 12 DC		2×10^6	
Rated operational voltage range	V	24 ... 48 DC	
Degree of protection		IP20	
Dimensions (H x W x D)	mm	102 x 22.5 x 92	
Rated temperature	°C	25	
Ambient temperature	°C	-25 ... +70	
Storage temperature	°C	-40 ... +85	
Addressing procedure		The module does not need its own AS-Interface address.	
Connection		Screw terminal	Spring-type terminal
Conductor cross-sections	mm ²		
• Solid		--	2 x (0.25 ... 1.5)
• Finely stranded with end sleeve		--	2 x (0.25 ... 1)
• Finely stranded without end sleeve		--	2 x (0.25 ... 1.5)
• AWG cables, solid or stranded		--	AWG 2 x (24 ... 16)
Use of repeaters		If repeaters are used, a ground-fault detection module must be used for each AS-Interface segment (number of AS-Interface power supply units = number of ground-fault detection modules)	

¹⁾ U_{aux} should be protected by a 2 A slow fuse.

²⁾ The endurance of the relay can be increased if inductive loads are connected using freewheel diodes.

Dimensional drawings

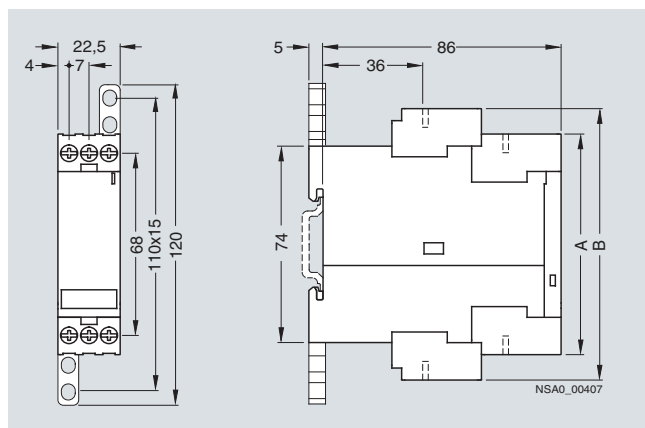

	A	B
Standard terminal		
Spring-type terminal	81,6	101,6
Screw terminal	80	100
Removeable terminal		
Spring-type terminal	84	103
Screw terminal	83	102

More information

You can find more information on the Internet at:

<http://www.siemens.com/as-interface>

AS-Interface

Slaves

Modules with special functions Overvoltage protection modules

Overview

The AS-Interface overvoltage protection module protects downstream AS-Interface devices or individual sections in AS-Interface networks from conducted overvoltages which can be caused by switching operations and remote lightning strikes.

The location of the overvoltage protection module forms within the lightning protection zone concept the transition from zone 1 to 2/3. Direct lightning strikes must be coped with using additional protective measures at the transitions from lightning protection zone 0A to 1.

With the AS-Interface overvoltage protection module it is now also possible to integrate AS-Interface in the overall lightning protection concept of a plant or machine.

The module has the same design, connection and degree of protection (IP67) as the AS-Interface user modules. It is a passive module without AS-i IC and as such does not need its own address on the AS-Interface network.

Connection to an AS-Interface system is effected through the FK-E or PG-E coupling module. Through use of the EEMS interface, the AS-Interface cable and the auxiliary voltage cable can be protected from overvoltage.

Overvoltages are discharged through a ground cable with a green/yellow oil-proof outer sheath. This cable is fixed in the

Configuration guidelines

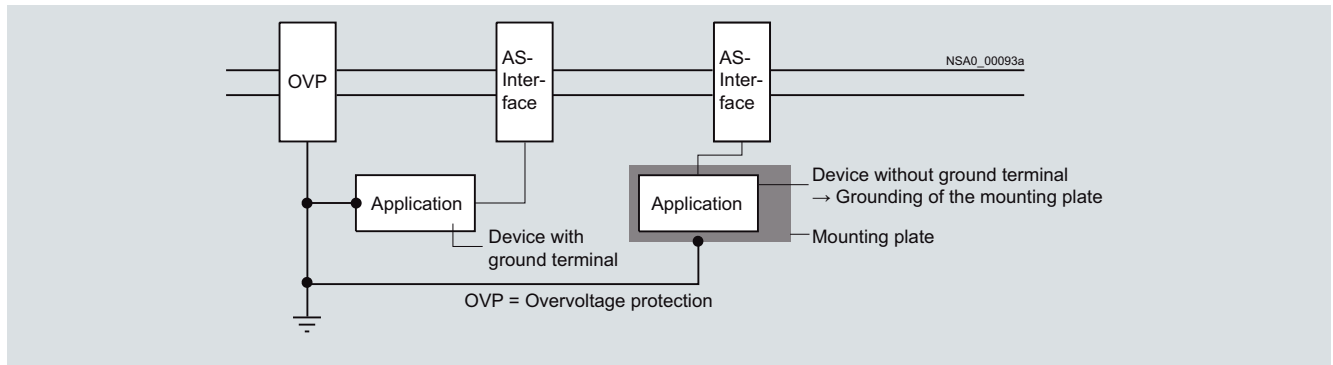

Configuration guidelines for overvoltage protection modules

The grounding of protection modules and the units to be protected must be effected through a shared grounding point

module and must be connected with low resistance to the system's ground.

Rated discharge current I_{sn}

The rated discharge current is the peak value of a surge current with waveform 8/20 microseconds, for which the overvoltage protection module is rated in according to a specific test program.

With waveform 8/20, 100 % of the value is achieved after 8 microseconds and 50 % after 20 microseconds.

Protection level U_p

The protection level of an overvoltage protection module is the highest momentary value of the voltage at the terminals, established in individual tests.

The protection level characterizes the capability of an overvoltage protection module to limit overvoltages to a residual level.

Accessories

An FK-E (3RG9030-0AA00) or PG-E (3RG9240-0AA00) coupling module is required for connection of the AS-Interface cable and the auxiliary power supply cable.

Sample application

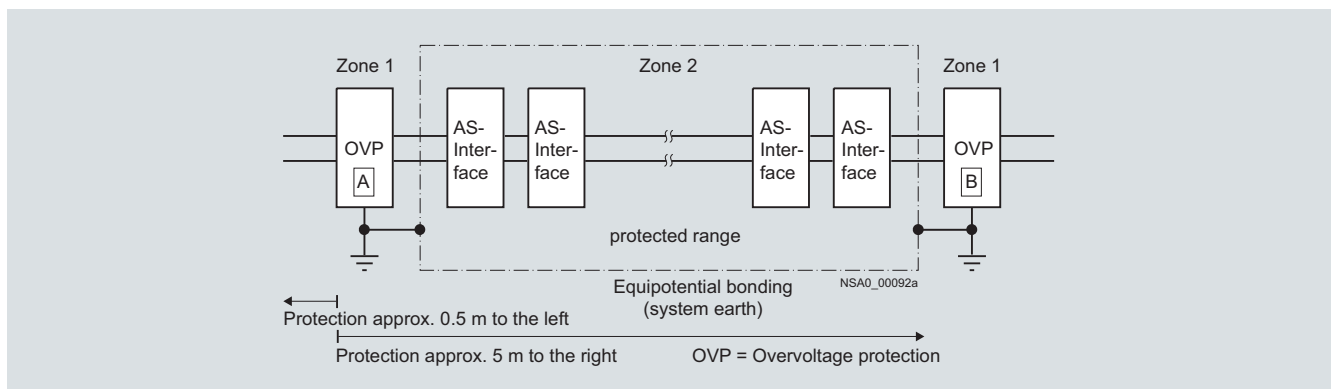

Sample application for overvoltage protection modules

(equipotential bonding). If insulated devices are protected, their mounts must be included in the grounding points.

Technical specifications

		Overvoltage protection modules	
		For AS-Interface 3RK1 901-1GA00	For AUX Power
Overvoltage protection			
• Rated discharge current I_{SN} of wave form 8/20			
- Core PE	kA	10	10
- Core-core	kA	0.5	0.5
• Protection level U_p at I_{SN}			
- Core PE	kV	≤ 1.8	≤ 1.8
- Core-core	V	≤ 100	≤ 70
• Protection level U_p at 1 kV / μ s			
- Core PE	V	≤ 700	≤ 600
- Core-core	V	≤ 50	≤ 40
Mechanical specifications			
• Degree of protection (with coupling module)		IP67	
• Dimensions (H x W x D)		mm 80 x 45 x 25	
Temperature range			
• Ambient temperature		°C -25 ... +85	
• Storage temperature		°C -40 ... +85	

Dimensional drawings

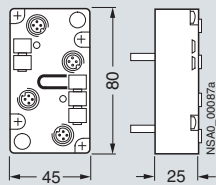

AS-Interface

Slaves

AS-Interface connections for LOGO!

Overview

Every LOGO! can now be connected to the AS-Interface system



Using the AS-Interface connection for LOGO!, an intelligent slave can be integrated in the AS-Interface system. With the modular interface it becomes possible to integrate the different basic units in the system according to their functionality. Similarly, functionalities can be quickly and easily adapted to new requirements by exchanging the basic unit.

The interface module provides four inputs and four outputs on the system. These inputs and outputs are not physical, however, but are only virtually present through the interface on the bus.

Technical specifications

Supply voltage	V	24 DC
Inputs/outputs		4/4 (virtual inputs/outputs)
Bus connection		AS-Interface acc. to specification
Ambient temperature	°C	0 ... +55
Degree of protection		IP20
Mounting		Onto standard mounting rail
Dimensions (W x H x D)	mm	36 x 90 x 58
Indications of the LEDs		
LEDs		Status
• Green		• OK
• Red		• No data traffic
• Flashes red/yellow		• Zero address

Overview



AS-Interface power supplies are an essential and functionally important part of an AS-Interface network. They supply the electronics of the network (AS-Interface modules and AS-Interface masters) and the connected sensor technology. Furthermore, the integrated data decoupling of AS-Interface power supplies ensures the separation of data and energy, thus enabling AS-Interface to transmit data and power on a single cable.

Design

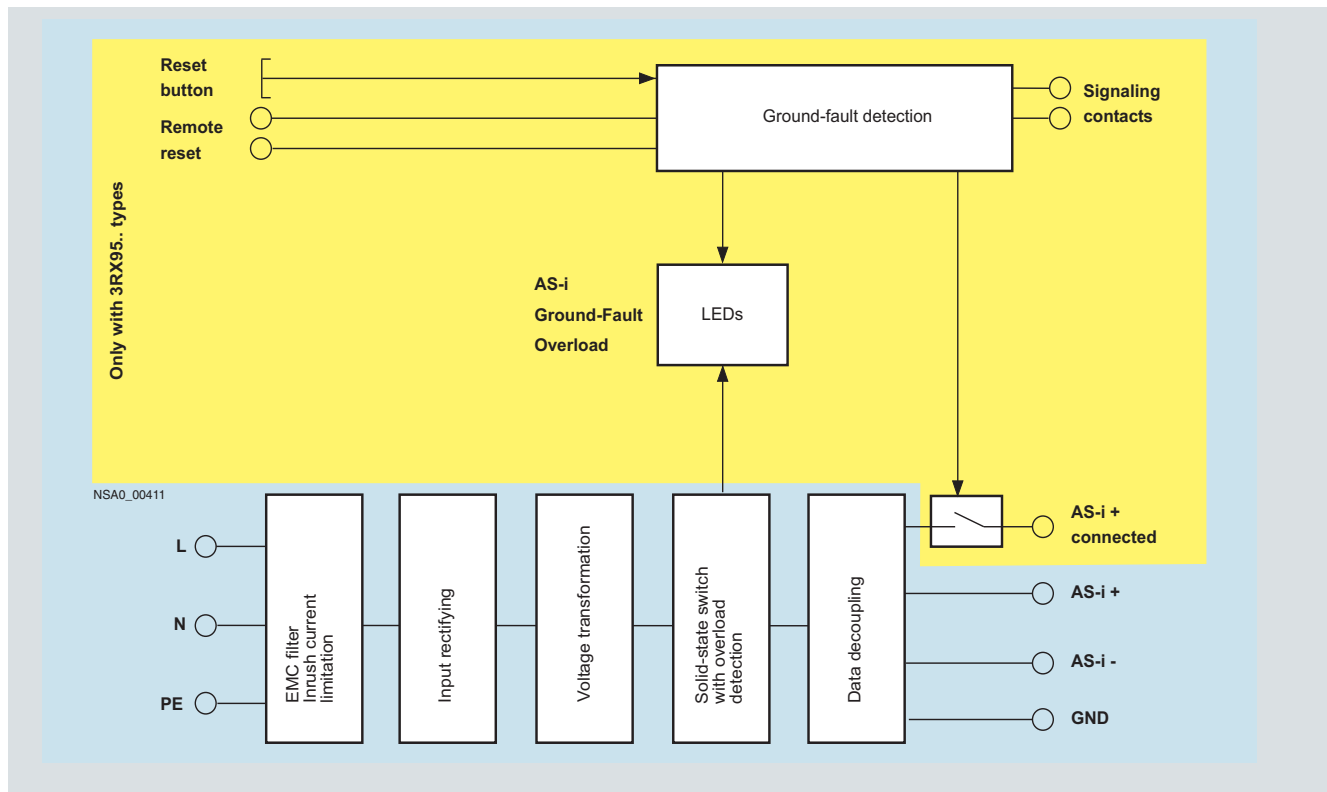

Basic design of the AS-Interface power supplies

AS-Interface power supply units are primary-controlled direct voltage supply units. The primary switched power supplies generate a controlled direct voltage of 30 V DC with high stability and low residual ripple.

Data and energy are always transmitted simultaneously over the AS-Interface 2-wire cable. AS-Interface power supplies must therefore not only ensure the power supply of the AS-Interface network, but also that of the data link.

Standard power supplies are not suitable for this purpose. For this reason, standard power supply units must not be used to supply an AS-Interface network. AS-Interface power supplies supply the electronics of the network (AS-Interface masters, AS-Interface modules) and all connected sensors. Graded power supply units with 2.6 to 8 A output current are available,

depending on the power requirements of the respective AS-Interface network. The 2.6 A version is approved according to NEC Class 2.

As shown in the graphics, the new generation of AS-Interface power supplies (3RX95...) is available in IP20 with integrated ground-fault and overload detection.

AS-Interface Power Supply Units

AS-Interface power supplies, IP20

Function

Features of the new 3RX9 5... power supply generation:

- **Compact dimensions**
With just 50/70/120 mm widths, the new devices are the most compact AS-Interface power supplies yet with an extremely high power density. The small footprint of these devices can be fully utilized as a further device can be mounted on the standard mounting rail directly next to the power supply unit. There is therefore no need for gaps between devices (as is often the case with other compact power supply units).
- **Higher rating**
The new devices have an output current of 3/5/8 A.
- **Integrated ground-fault detection**
Ground-fault detection to EN 60204-1 comes as standard with AS-Interface. The new generation of AS-Interface power supplies are all equipped with integrated ground-fault detection, which reliably detects and reports any ground faults. Furthermore, by setting up additional contacts, users can specify whether the AS-Interface voltage should be switched off immediately in the event of a ground fault, thus preventing unintentional startup of a machine. This prevents damage to the system in the event of a fault.
- **Integrated overload detection**
An output overload is detected and reported over a diagnostics LED.
- **Diagnostics memory**
Any ground faults or overloads on the output side are stored in a diagnostics memory until the device is reset. This facilitates fault diagnostics on an AS-Interface network as a service technician can immediately see where any faults in the system are coming from (even after the fault has occurred).
- **Remote reset and remote indication**
The recognized ground fault can be reported to a central control system over established contacts and evaluated. The stored diagnostics can be reset locally over a reset button. It can also be reset by a control system over a reset input.
- **Diagnostics LEDs**
Three different colored LEDs indicate the status of the AS-Interface power supply locally at the power supply unit.
- **Ultra-wide input range for 8 A version**
The ultra-wide input range of 120 to 500 V of the 8 A variant means that the supply units can be used in virtually any network worldwide. In addition, this version dispenses with the need for an N conductor as the device can be connected directly between 2 phases of a network.
- **Removable terminal blocks with spring-type connections**
Each power supply unit has three terminal blocks; one block each for the input side, the output side and the information terminal respectively. These can be removed and enable fast replacement of the power supply unit in the event of a fault. The spring-type terminals also enable fast and permanently stable mounting of cable wires.

Technical specifications

		AS-Interface power supply units				
		Single output IP20				
		Output current 2.6 A Class 2 3RX9 501-2BA00	Output current 3 A 3RX9 501-0BA00	Output current 3 A 3RX9 501-1BA00	Output current 5 A 3RX9 502-0BA00	Output current 8 A 3RX9 503-0BA00
Input data						
• Primary voltage U_e	V	120/230 AC	120/230 AC	24 DC	120/230 AC	120/230 ... 500 AC
• Operational voltage range	V	85 ... 132/ 176 ... 253 AC	85 ... 132/ 76 ... 253 AC	20 ... 29 DC	85 ... 132/ 76 ... 253 AC	85 ... 132/ 76 ... 550 AC
• Mains frequency range	Hz	47 ... 63	47 ... 63	--	47 ... 63	47 ... 63
• Mains buffering at $I_{a \text{ rated}}$	ms	--	> 20	> 10	> 20	> 20
• Rated primary current	A	1.4/0.8	1.6/0.9	4.5	2.7/1.5	4.4/2.4
Output data						
• Rated output voltage $U_{a \text{ rated}30}$	V	30 DC	30 DC	30 DC	30 DC	30 DC
• Residual ripple/spikes		< 50 mVpp (10 ... 500 kHz) < 300 mVpp (0 ... 10 kHz)	< 50 mVpp (10 ... 500 kHz) < 300 mVpp (0 ... 10 kHz)	< 50 mVpp (10 ... 500 kHz) < 300 mVpp (0 ... 10 kHz)	< 50 mVpp (10 ... 500 kHz) < 300 mVpp (0 ... 10 kHz)	< 50 mVpp (10 ... 500 kHz) < 300 mVpp (0 ... 10 kHz)
• Rated output current $I_{a \text{ rated}}$	A	2.6	3	3	5	8
• Making-current limiting	A	Typ. 3.0	Typ. 3.5	Typ. 3.5	Typ. 5.5	Typ. 8.5
• Degree of efficiency at full load	%	Typ. 84	Typ. 84	Typ. 84	Typ. 87	Typ. 87
Ambient conditions						
• Storage/transport temperature	°C	-25 ... +80	-25 ... +80	-25 ... +80	-25 ... +80	-25 ... +80
• Ambient operating temperature	°C	-10 ... +70	-10 ... +70	-10 ... +70	-10 ... +70	-10 ... +70
• Degree of protection		IP20	IP20	IP20	IP20	IP20
• Degree of pollution		2	2	2	2	2
• Humidity class		Climate class DIN 50010, relative air humidity max. 100 %, without condensation				
• EMC emitted interference class B		IEC 61000-6-3				
• EMC interference immunity		EN 61000-6-2, EN 61000-4-2/-3/-4/-5/-6/-11				

Dimensional drawings

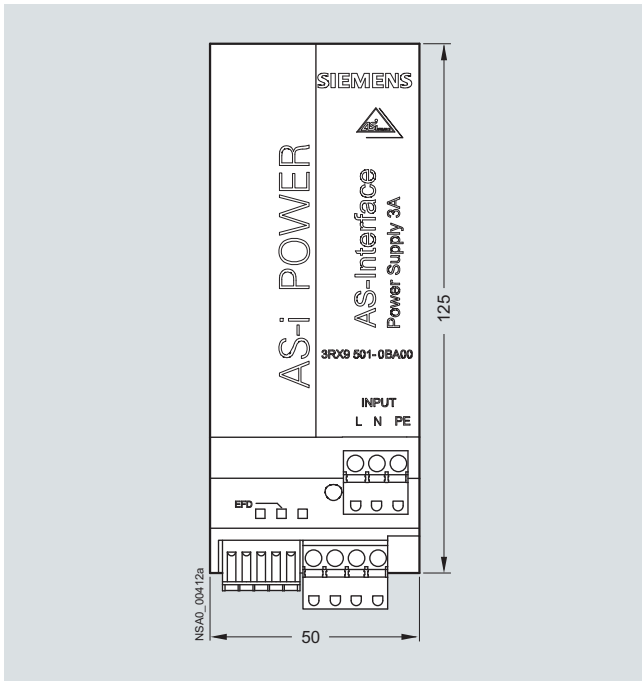

Front view 3RX9 501-0BA00, 3RX9 501-1BA00, 3RX9 501-2BA00

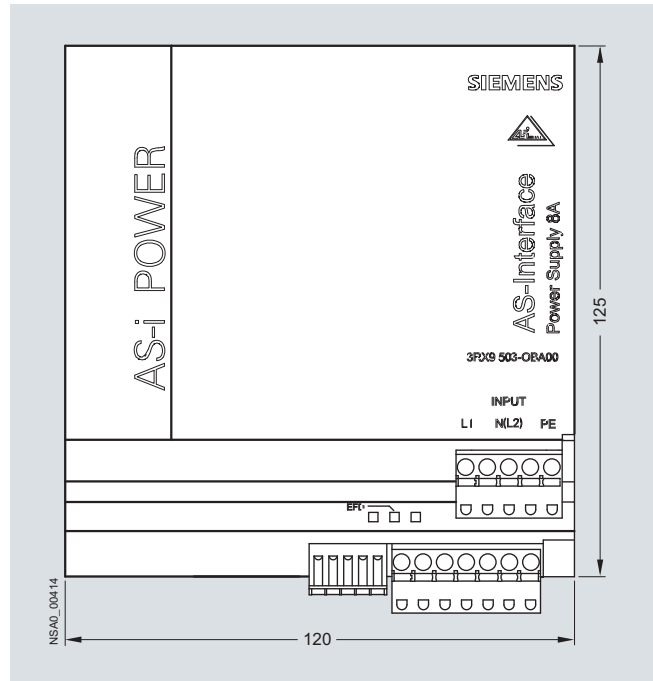

Front view 3RX9 503-0BA00

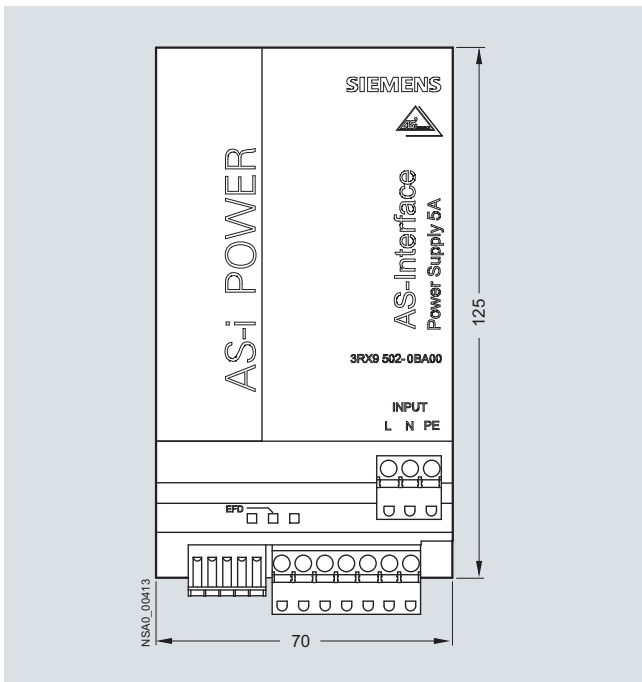

Front view 3RX9 502-0BA00

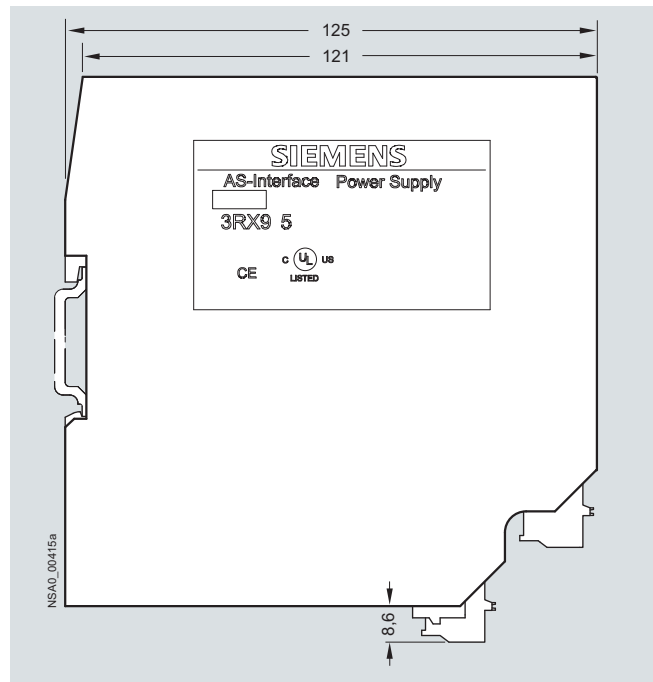

Side view 3RX9 501-0BA00, 3RX9 501-1BA00, 3RX9 501-2BA00, 3RX9 502-0BA00, 3RX9 503-0BA00

AS-Interface Transmission Media

AS-Interface shaped cables

Overview



The actuator-sensor interface - the networking system used for the lowest field area - is characterized by very easy mounting and installation. A new connection method was developed specially for AS-Interface.

The stations are connected using the AS-Interface cable. This two-wire cable has a trapezoidal shape, thus ruling out polarity reversal.

Connection is effected by the insulation piercing method. In other words, male contacts pierce the shaped AS-Interface cable and make reliable contact with the two wires. Cutting to length and stripping are superfluous. Consequently, AS-Interface stations (e. g. I/O modules, intelligent devices) can be connected in the shortest possible time and exchanging devices is quick.

To enable use in the most varied ambient conditions (e. g. in an oily environment), the AS-Interface cable is available in different materials (rubber, TPE, PUR).

For special applications it is also possible to use a standard round cable. With AS-Interface, data and power for the sensors (e. g. BERO proximity switches) and actuators (e. g. indicator lights) are transmitted over the yellow AS-Interface cable.

The black cable must be used for actuators with a 24 V DC supply (e. g. solenoid valves) and a high power requirement.

Suitable for operation in tow chains

The use of the AS-Interface shaped cables with TPE and PUR outer sheath was checked in a tow chain test with the following conditions:

Chain length	m	6
Travel	m	10
Bending radius	mm	75
Travel speed	m/s	4
Acceleration	m/s ²	4
Number of cycles		10 million
Duration of test		Approx. 3 years (11000 cycles per day)

After termination of the 10 million cycles only slight wear was visible due to the lugs of the tow chain. The cores and core insulation no damage could be detected.

Note:

When using a tow chain the cables must be installed free from tensile forces. On no account may the cables be twisted, but must be routed flat through the tow chain.

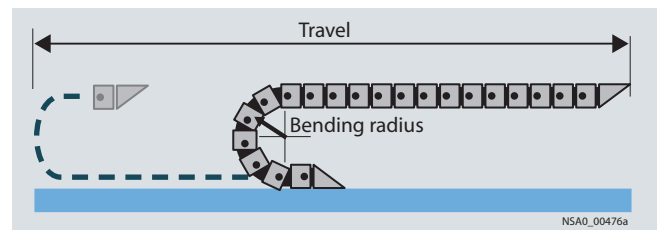

Tow chain

Technical specifications

		AS-Interface shaped cables			
		EPDM (rubber)	TPE (special PVC compound)	TPE special version acc. to UL Class 2	PUR (polyurethane)
Application temperature range	• Stationary °C	-40 ... +85	-40 ... +105	-30 ... +90	-50 ... +90
	• Moved °C	-25 ... +85	-30 ... +105	-20 ... +90	-50 ... +90
Core colors		Brown, blue	Brown, blue	Brown, blue	Brown, blue
Flexibility		Very good	Good	Good	Good
Fire behavior		Flammable	Flame-retardant acc. to IEC 60332-1 VDE 0482 T. 265-2-1 UL 1581 sec. 1061 cable flame UL 1581 sec. 1060 CSA FT1	Flame-retardant acc. to IEC 60332-1 VDE 0482 T. 265-2-1 UL 1581 sec. 1061 cable flame UL 1685 CSA FT4	Flame-retardant acc. to IEC 60332-1 VDE 0482 T. 265-2-1
Without halogens (PVC-free)		Yes	No	No	Yes
Without silicone precipitation		Yes	Yes	Yes	Yes
Ozone and weather resistant		Conditionally resistant	Resistant	Resistant	Resistant
Oil resistance		Conditionally resistant	Resistant	Resistant	Resistant
Smallest permissible bending radii acc. to DIN VDE 0298, Part 300	mm				
• Fixed		12	12	12	12
• Freely movable		24	24	24	24
Smallest permissible bending radii acc. to DIN VDE 0298, Part 300	mm				
• Fixed		12	12	12	12
• Freely movable		24	24	24	24
UL approval		No	UL 758 AWM	UL 758 AWM, UL 13 Class 2, UL 444 CMG	No
CSA approval		No	C22.2 No.210.2 AWM	C22.2 No. 214-02	No
Monitored expertise (VDE)		No	No	No	VDE Reg. No.9971, 300 V/500 V Stationary: -40 ... +70 °C Transport: -25 ... +70 °C Moved: -15 ... +70 °C Approved for marine and offshore use up to 300 V/500 V: Germanischer Lloyd, Lloyds Register of Shipping, ABS Europe LTD, Bureau Veritas, Det Norske Veritas

Dimensional drawings

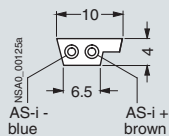

AS-Interface

System Components and Accessories

Repeaters/extenders

Overview



AS-Interface repeater (left) and AS-Interface extender (right)

- Repeaters for extending the AS-Interface cable by 100 m per repeater
- Extenders for increasing the distance (max. 100 m) between a master and the AS-Interface segment
- Maximum two repeaters or one extender and one repeater in series
- Parallel switching of several repeaters possible (star configuration option)
- Maximum size increase of an AS-Interface network to more than 500 m is thus possible
- Easy mounting
- IP67 module enclosure

Design

Repeaters

- Slaves can be used on both sides of the repeater
- AS-Interface power supply is required on both sides
- Electrical isolation of the two AS-Interface shaped cable lines
- Installed in K45 module enclosure with mounting plate
- Separate indication of the correct AS-Interface voltage for each side
- Maximum two repeaters in series (max. cable length 300 m)
- Parallel switching of several repeaters possible (star configuration)
- Combination of series and parallel switching possible (max. range 500 m)

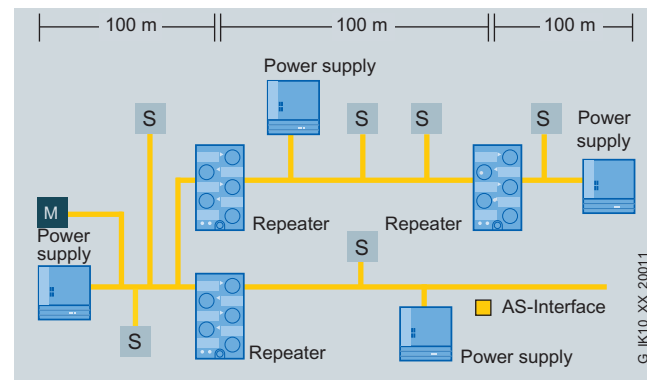

Extenders

- Master can be placed up to 100 m from the actual AS-Interface segment
- Slaves can be used only on the side facing away from the master
- AS-Interface power supply required only on the side facing away from the master
- No electrical isolation of the two AS-Interface shaped cable lines
- Indication of the correct AS-Interface voltage
- Installed in user module enclosure with FK-E coupling module as base

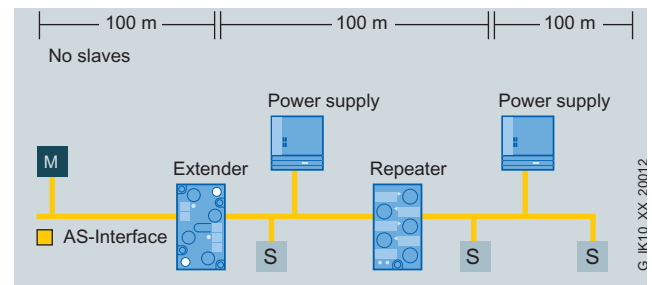

Extender connection

Note:

The extender cannot be used with the DP/AS-Interface Link 20E.

Overview



With the extension plug/extension plug plus it is possible to double the cable length possible in an AS-Interface segment from 100 to 200 m.

The extension plug/extension plug plus is a passive component which is connected to that point of the AS-Interface network that is furthest away from the power supply. It has an M12 plug for quick connection to the AS-Interface M12 feeder with degree of protection IP67.

Only one power supply unit is needed to supply power to the slaves on the up to 200 m long segment.

The extension plug/extension plug plus has integrated undervoltage detection for monitoring the AS-Interface voltage in order to be sure that the necessary voltage still exists at the end of the bus cable. Undervoltage is signaled on the extension plug by means of a diagnostics LED. The extension plug plus is equipped with an AS-Interface slave and communicates this diagnostics information directly to the AS-Interface master.

Design

Installation in the AS-Interface network

Maximum cable length and installation site

To construct an AS-Interface segment with a cable length of more than 100 m and up to a maximum of 200 m, the extension plug/extension plug plus is installed at that point of the network which is furthest from the AS-Interface power supply unit. This point does not have to be localized exactly; it suffices to connect the extension plug/extension plug plus in its vicinity (approx. ± 10 m).

Possible AS-Interface network structure

As with all AS-Interface networks, any network structure (line, tree, star) is possible when using the extension plug/extension plug plus. Only one extension plug/extension plug plus is required per 200-m segment even with a tree or star structure.

Addressing

As a passive network component the extension plug does not need an AS-Interface address. The extension plug plus has an integral AS-Interface A/B slave for the diagnostic signal and thus requires an AS-Interface address. For addressing purposes, the extension plug plus is simply plugged on the 3RK1 904-2AB01 addressing unit.

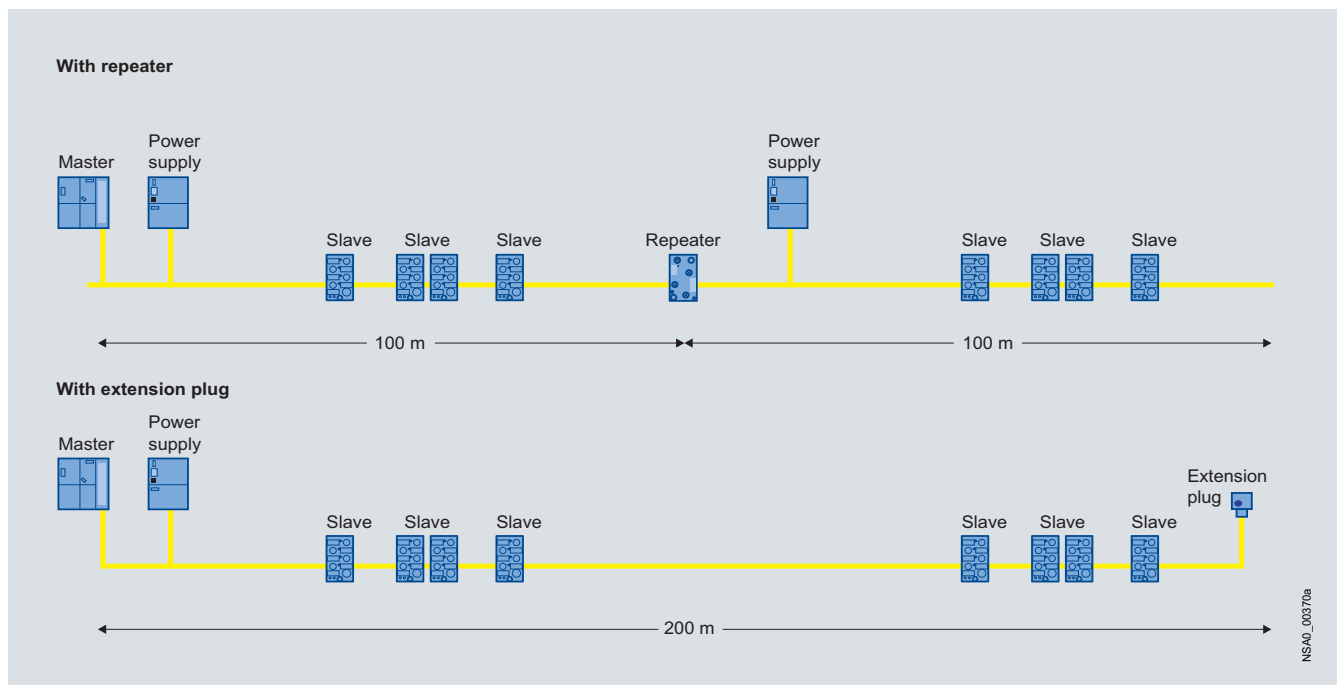

Topology of an AS-Interface network with a size of 200 m

AS-Interface System Components and Accessories

Extension plugs

Connection

The extension plug/extension plug plus is connected using an M12 plug-in connection and most easily realized with the help of the 3RX9 801-0AA00 AS-Interface M12 feeder to IP67 degree of protection.

Use of repeaters

For particularly large AS-Interface networks the maximum possible cable length can be increased further by using repeaters. Please note that when a repeater and an extension plug/extension plug plus are used together, the series connection of repeaters is not possible. Hence the maximum possible distance from the master to a slave is 400 m and the absolute maximum cable length is 600 m. The parallel connection of repeaters for a star-shaped configuration with segments up to 200 m long respectively is possible.

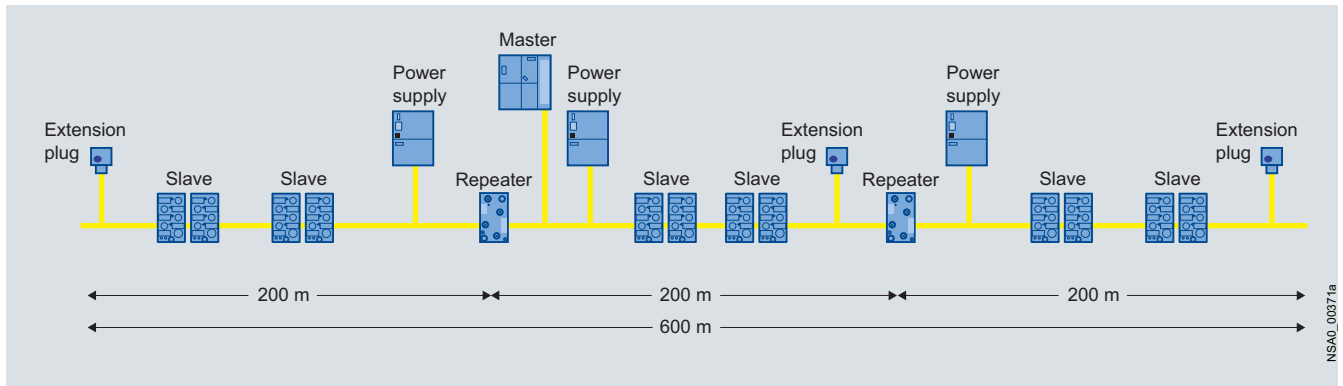

Maximum network size with repeaters and extension plug (master at center of network)

Function

Voltage monitoring

Signal upon undershooting of the minimum voltage

Depending on the size of an AS-Interface segment and the power consumption (the power consumption varies with the number of stations connected), it is important to make sure that the voltage drop along the AS-Interface cable does not become excessive.

To guarantee that even the remotest slave is still supplied with the necessary minimum voltage, the extension plug has a voltage monitor. With the extension plug, any undershooting of the minimum voltage in accordance with the AS-Interface specification is clearly indicated by flashing of a green LED; a correct AS-Interface voltage is signaled by steady illumination of the green LED.

Detection of also short-time voltage dips

The undervoltage detection has a delay for the LED indication in order to recognize also short-time voltage dips of the type which occur, for example, when actuators are switched. The extension plug plus is equipped with an AS-Interface slave. Instead of the diagnostics LED, the extension plug plus communicates the diagnostics information directly to the AS-Interface master. Two different voltage values can be set as threshold value. Using two diagnostics bits it is possible to distinguish between brief and lengthy voltage drops.

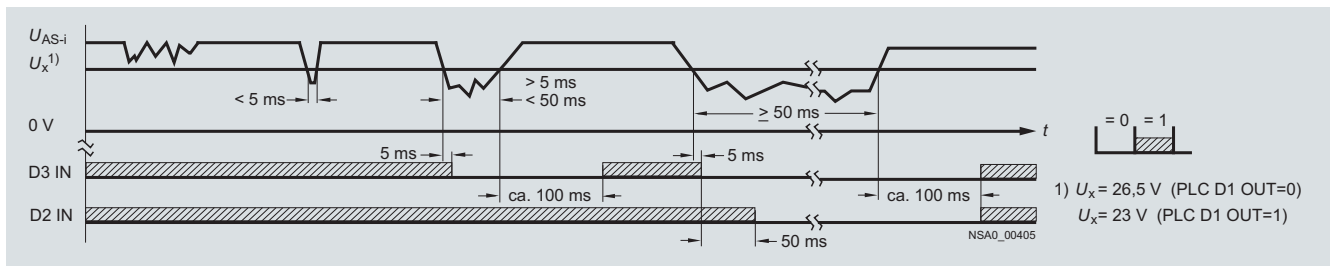

Transmission of the diagnostic signal with the extension plug plus

Technical specifications

		Extension plug 3RK1 901-1MX00	Extension plug plus 3RK1 901-1MX01
Operational voltage acc. to AS-Interface specification	V	26.5 ... 31.6	26.5 ... 31.6
Reverse polarity protection U_{AS-i}		Yes	Yes
AS-Interface certificate		Under application	Under application
Degree of protection		IP67	IP67
Ambient temperature	°C	-25 ... +85	-25 ... +85
Status display U_{AS-i}			
• LED On: U_{AS-i}	V	26.5 ... 31.6	None
• LED flashes: U_{AS-i}	V	10 ... 26.5	None
Power supply		From AS-Interface	From AS-Interface
Total current input	mA	≤ 10	≤ 15
Slave type		No slave integrated	A/B slave
I/O configuration		--	B
ID/ID2 code		--	I/O
Assignment of data bits			
• OUT1 (D0)		--	Not required
• OUT2 (D1)		--	D1 = 0: switching threshold 26.5 V D1 = 1: switching threshold 23 V
• IN3 (D2)		--	D2 = 0: undervoltage > 50 ms D2 = 1: no undervoltage
• IN4 (D3)		--	D3 = 0: undervoltage > 5 ms D3 = 1: no undervoltage
Connection to AS-Interface		Using M12 plug-in connector	Using M12 plug-in connector
Pin assignment			
• Pin 1		$U_{AS-i} +$	$U_{AS-i} +$
• Pin 3		$U_{AS-i} -$	$U_{AS-i} -$

AS-Interface

System Components and Accessories

Addressing units

Overview



To be able to participate in data exchange with the master, all stations have to be addressed before the AS-Interface network is configured. This can be done

- Offline by means of an addressing unit or
- Online using the master of the AS-Interface system.

The addresses themselves are the values 1 to 31 (or 1A to 31A and 1B to 31B for the extended AS-Interface specification 2.1). A new slave that has not yet been addressed has the address 0. It is recognized accordingly by the master as a new slave that has not yet been addressed and as such is not yet included in the normal communication.

The address can be assigned at random, i. e. it makes no difference whatsoever if the slave with address 21 begins or if the first slave is actually issued with address 1.

Function

- Reading out the slave address 0 to 31, A/B
- Reading out the I/O and ID codes of the slaves
- Standard and extended ID Code1 and ID Code2
- Standard and extended addressing mode according to AS-Interface Version 2.1
- Programming of the ID Code1
- Function testing of slaves: reading inputs and writing outputs from digital or analog slaves
- AS-Interface test: Measurement of voltage (measuring range 0 to 35 V) and current consumption (measuring range 0 to 100 mA) of the AS-Interface bus
- Storage: Complete system configurations can be stored (profiles of all slaves, also with extension according to AS-Interface specification 2.1)
- Detection of complete system complements

Technical specifications

		AS-Interface addressing and diagnostics units
		3RK1 904-2AB01
Power supply		The standard power supply is provided by 4 batteries according to IEC LR6 (NEDA 15), which guarantee that the unit can perform at least 2500 device addressings For a longer battery life the unit is switched off automatically approx. 1 minute after the last operation
Ambient conditions		
• Working temperature range	°C	0 ... +55
• Storage temperature range	°C	-20 ... +55 (without batteries)
• Relative air humidity	%	Max. 75, condensation not permitted
• Altitude above sea level	m	Up to 2000
• Location		Only in indoor rooms
Mechanical design		
• Degree of protection		IP40
• Dimensions (W x H x D)	mm	84 x 195 x 35
• Connection		Using M12 socket: <ul style="list-style-type: none"> • Pin 1: AS-i + • Pin 3: AS-i -/GND • Pin 2/4/5: IR addressing

AS-Interface

System Components and Accessories

AS-Interface analyzers

Overview



The AS-Interface analyzer is used to test AS-Interface networks. It enables systematic troubleshooting and permanent monitoring.

Installation errors, e. g. loose contacts or EMC interference under extreme loads, can be revealed by this device.

Thanks to the easy-to-use software the user can assess the quality of complete networks even if he lacks detailed specialist knowledge of AS-Interface. In addition it is an easy matter with the AS-Interface analyzer to create test logs from the records produced, thus providing documentation for start-ups and service assignments.

For advanced AS-Interface users there are trigger functions for detailed diagnostics.

Connection

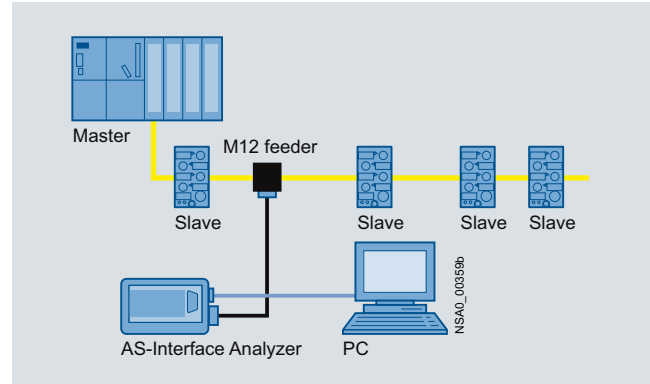

The AS-Interface analyzer follows the communication on the AS-Interface network as a passive station. The unit is supplied simultaneously from the AS-Interface cable.

The analyzer interprets the physical signals on the AS-Interface network and records the communication.

The data thus obtained are transferred through an RS 232 interface to a PC such as a notebook, for evaluation with the supplied diagnostics software.

Technical specifications

		AS-Interface analyzers
		3RK1 904-3AB01
Interfaces		<ul style="list-style-type: none"> AS-Interface RS 232 for connection to a PC Trigger input (24 V) Trigger output (TTL)
Displays/LEDs		<ul style="list-style-type: none"> Supply voltage OK (power) RS 232 interface in operation Test mode
Statistics mode		Online view or long-term measurement up to 14 days (without PC) or one year (with PC)
Trace mode		Message frame memory for 256000 AS-Interface message frames
Rated operational current	mA	Approx. 70 from AS-Interface
Rated insulation voltage	V	> 500
EMC		Acc. to EN 50081-2, EN 61000-6-2
Ambient temperature	°C	0 ... +55
Storage temperature	°C	-25 ... +70
Requirements		IBM compatible PC 80486 and higher
Operating system		Windows 95/98, Windows ME, Windows NT, Windows 2000, Windows XP, Windows Vista (Home Premium/Business/Ultimate 32)

AS-Interface

System Components and Accessories

Miscellaneous accessories

Technical specifications

		AS-Interface M12 feeder						AS-Interface M12 quadruple feeder
		AS-i flat cables			AS-i/U _{aux} flat cables			
		Onto M12 socket	Onto M12 cable box		Onto M12 socket	Onto M12 cable box		Onto quadruple M12 socket
			1 m	2 m		1 m	2 m	
		3RK1 901-1NR10	3RK1 901-1NR11	3RK1 901-1NR12	3RK1 901-1NR20	3RK1 901-1NR21	3RK1 901-1NR22	3RK1 901-1NR00
Operational voltage max.	V	30 DC						
Current carrying capacity total	A	4						
Socket assignment		Pin 1: AS-i + Pin 2: Not assigned Pin 3: AS-i - Pin 4: Not assigned			Pin 1: AS-i + Pin 2: U _{aux} - Pin 3: AS-i - Pin 4: U _{aux} +			
Degree of protection		IP67/IP68/IP69K						IP67
Ambient temperature	°C	-25 ... +75						-25 ... +85
Storage temperature	°C	-25 ... +85						-40 ... +85
Tightening torques for fixing screws	NM	0.8						
Special features of the flat cable		Flat cable must be routed through the M12 feeder						Flat cable can be terminated in the feeder
Connection								Using FKE coupling module (included in scope of supply)

		M12-T distributors	
		3RK1 901-1TR00	
Voltage range	V	20 ... 30 DC	
Current carrying capacity total	A	4 at T = 40 °C	
Connection		M12	
Degree of protection		IP68	
Ambient temperature	°C	-25 ... +85	
Storage temperature	°C	-25 ... +85	
Number of M12 sockets		1 × M12 plug/2 × M12 box	

		Standard distributors	Compact distributors	Cable terminating pieces
		3RK1 901-1NN00	3RK1 901-1NN10	3RK1 901-1MN00
Ambient temperature	°C	-40 ... +85	-25 ... +85	-40 ... +85
Degree of protection		IP65	IP67/IP68/IP69K	IP67 with inserted shaped AS-Interface cable
Current carrying capacity total	A	7 at T = 50 °C	6	--
Mounting		Standard rail mounting/wall mounting	Wall mounting	Cable terminating piece can be fastened, e. g. to a machine, using the integrated eyelet
Special features of the cable end		To terminate one or both cables in the standard distributor, seals (straight and shaped) for inserting in the base of the distributor are required. These seals are not included in the scope of supply and must be ordered separately (3RK1 902-0AR00). If both cables are to be routed completely through the module, no additional seals are required.	Cables cannot be terminated in the compact distributor.	

AS-Interface System Components and Accessories

Miscellaneous accessories

Dimensional drawings

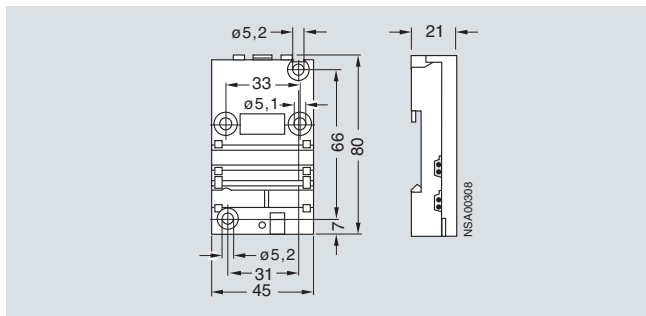

AS-Interface standard distributor, for AS-Interface flat cable (3RK1 901-1NN00)

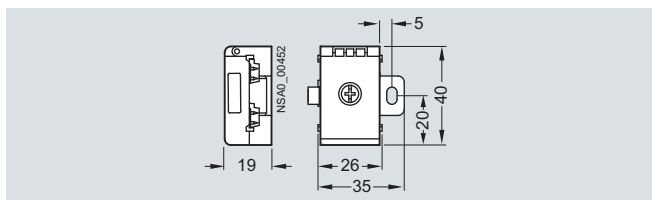

AS-Interface compact distributor, for AS-Interface flat cable (3RK1 901-1NN10)

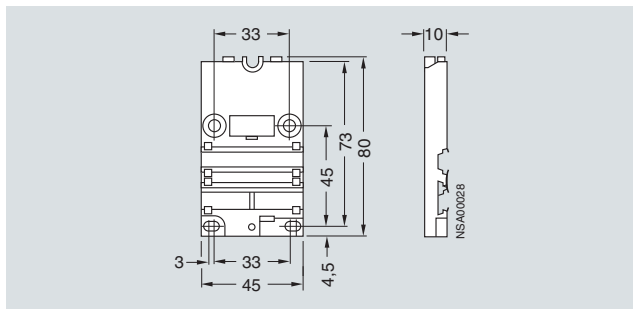

3RK1 901-2EA00 mounting plate for K45 modules, for wall mounting Arrangement and drilled holes identical to that of the K60 compact module

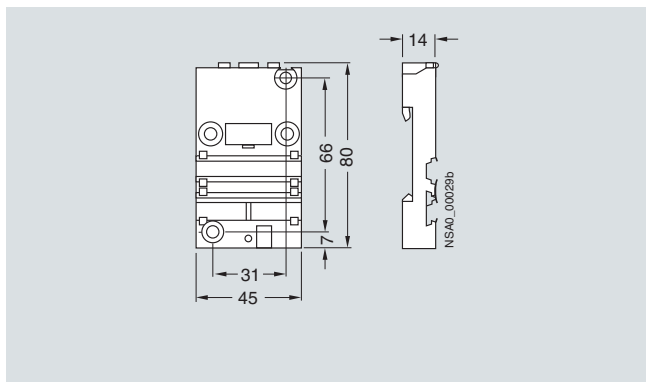

3RK1 901-2DA00 mounting plate for K45 modules, for standard rail mounting Arrangement and drilled holes identical to that of the user module

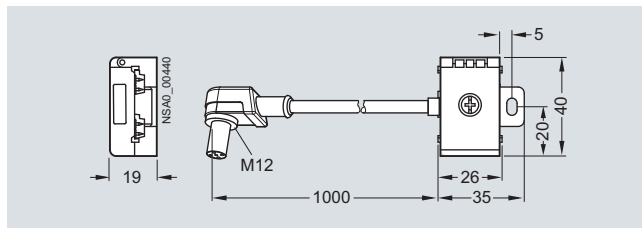

AS-Interface M12 feeder, AS-i/U_{aux}, M12 cable box, 1 m cable length (3RK1 901-1NR21)

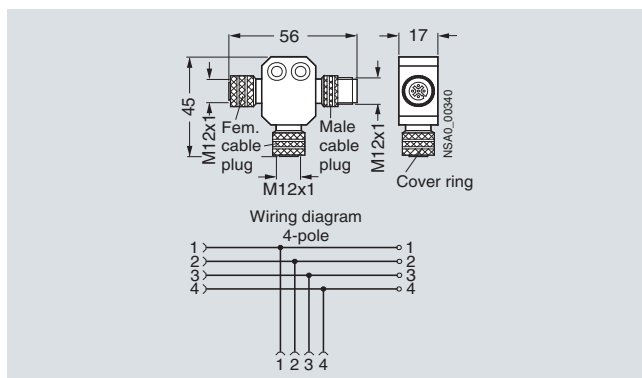

M12-T distributor (3RK1 901-1TR00)

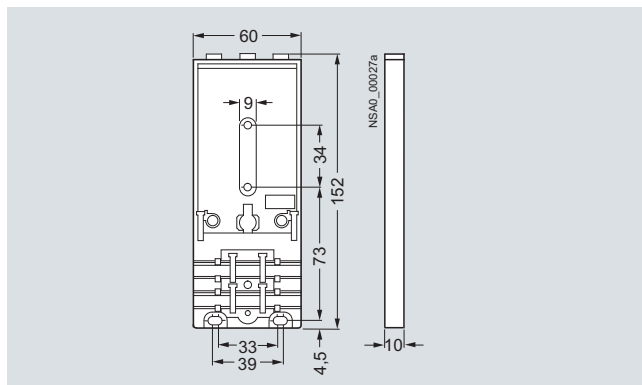

3RK1 901-0CA00 mounting plate for K60 modules, for wall mounting

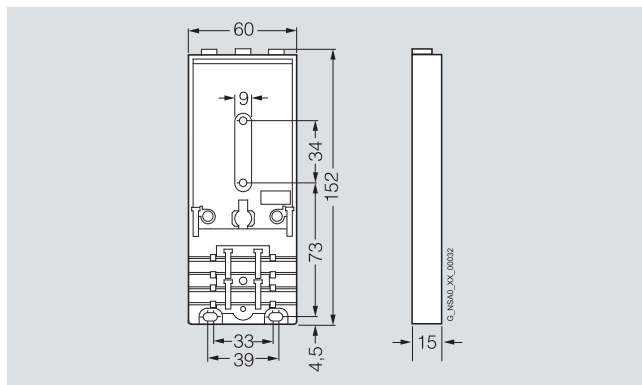

3RK1 901-0CB01 mounting plate for K60 modules, for standard rail mounting

System overview

Overview



IO-Link range

IO-Link is a new, innovative and standardized communication module for sensors and actuators - defined by the Profibus User Organization (PNO). IO-Link technology is based on the point-to-point connection of sensors and actuators to the control system. As such it is not a bus system but constitutes a considerable upgrade of the classic point-to-point connection. Extensive parameter and diagnostics data are transmitted in addition to the cyclic operating data for the connected sensor/actuators. The connection technology used is based on the same 3-wire connecting cables customary in today's standard sensor systems.

Components of an IO-Link system:

Only 2 components are required to use IO-Link:

- IO-Link master
- IO-Link device (e. g. IO-Link sensor/actuator, IO-Link I/O module)

Benefits

The IO-Link system offers decisive advantages for connecting complex (intelligent) sensors/actuators:

- Dynamic changing of sensor/actuator parameters directly by the PLC
- Consistent storage of parameters enables devices to be exchanged during operation without need for re-parameterization
- Fast commissioning thanks to central data storage
- Consistent diagnostic information as far as the sensor/actuator level
- Uniform and greatly reduced wiring of different sensors/actuators
- Reduction of parameterization tools
- Integrated communication: Transmission of process data and service data between sensors/actuators and the control system
- Uniform and transparent configuring and programming through use of a parameterization tool integrated in SIMATIC Step 7 (PCT)
- Transparent representation of all parameter and diagnostics data
- Lower configuring and commissioning costs
- Signals and indicators for preventive maintenance

Compatibility of IO-Link

IO-Link guarantees compatibility between IO-Link-capable modules and standard modules as follows:

- IO-Link sensors/actuators can be operated on IO-Link modules (master) as well as on standard I/O modules.
- IO-Link sensors/actuators as well as today's standard sensors/actuators can be used on IO-Link modules (masters).
- If conventional components are used in the IO-Link system, then of course only the standard functions are available at this point.

Expansion through IO-Link I/O modules

IO-Link compatibility also permits connection of standard sensors/actuators, i. e. conventional sensors/actuators can also be connected to IO-Link. This is done particularly economically with IO-Link I/O modules which enable several sensors/actuators to be connected to the control system simultaneously over one cable.

Analog signals

Another advantage of IO-Link technology is that analog signals are digitized already in the IO-Link sensor itself and are digitally transmitted by the IO-Link communication. As the result, faults are prevented and there is no extra cost for cable shielding.

Integration in STEP7

Integration of the device configuration in the STEP7 environment

- Easy and quick engineering
- Consistent data storage
- Speedy locating and rectifying of faults

Productivity is thus increased throughout all plant lifecycle phases – from configuration and start-up to operation. Thanks to the Siemens IO-Link solution, even sensors and actuators below fieldbus level can be integrated to optimum effect with all their capabilities in the Totally Integrated Automation (TIA) environment.

Application

IO-Link is used in two main applications. First, with IO-Link it is easy to connect even complex sensors with very many parameters to the control system. Second, technology based on IO-Link modules is an optimum substitute for passive distributors in connecting binary sensors. In both applications, all the diagnostics data are transmitted to the higher-level control system through IO-Link.

Advantages for users (example)

When a complex pressure sensor is used, numerous parameters (e. g. threshold values, hysteresis values) are set during commissioning for the plant to run smoothly. These data are sent through IO-Link to the control system and stored there. If this sensor fails and has to be replaced, all that is required is to exchange the sensor itself. The necessary parameters are then called up from the control system and loaded through IO-Link into the sensor. Without IO-Link, the sensor would have to be parameterized anew at great cost of time and effort.

Overview



IO-Link I/O modules

Using IO-Link technology it is also possible to connect standard sensors to IO-Link masters. However, connecting standard sensors directly to the IO-Link master does not exploit the full potential of IO-Link. The solution lies in the technology of the IO-Link modules. The use of this technology represents a more attractive solution in terms of cost than the direct connection of sensors/actuators.

IO-Link I/O modules are a useful addition to ET200S distributed peripherals.

The technology of the IO-Link I/O modules expands IO-Link from a pure point-to-point wiring method in the direction of distributed structures. It must be noted however that the cable length of an IO-Link connection restricts the distance of an IO-Link module from the master to a maximum of 20 m.

The use of passive distributors with accordingly complex and error-prone wiring is no longer necessary.

Transmission of parameter and diagnostic signals

With IO-Link I/O modules it is possible in addition to transmit parameter and diagnostic signals. This enables for example the inputs of modules to be parameterized as NC contacts or NO contacts through IO-Link. An overload or short-circuit in the sensor supply is signaled to the control system through the IO-Link master.

M8 and M12 terminals

M8 and M12 terminals are available for connecting the sensors. Connection to the IO-Link master is made using a standard M12 connecting cable.

Function

IO-Link I/O modules are used in particular where passive distributors were used up to now for the connection of binary sensors.

Application example: replacement of passive distributors through the use of IO-Link I/O modules

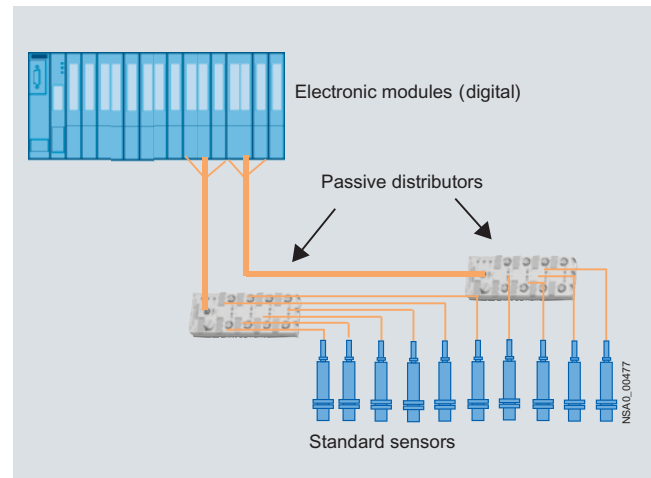

Former technology with passive distributors.

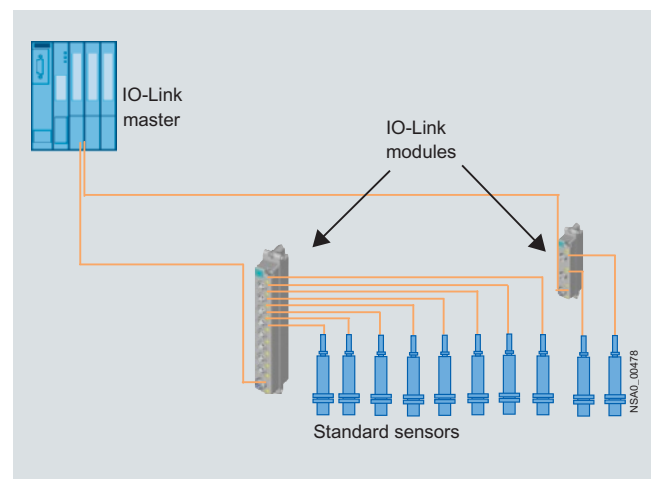

Technology with IO-Link I/O modules

I/O modules

IO-Link K20 modules

Technical specifications

	IO-Link K20 module	
	4 digital inputs	8 digital inputs
	M12	M8
	Y assignment	Standard assignment
	3RK5 010-0BA10-0AA0	3RK5 010-0CA00-0AA0
Number of I/O sockets	2	8
IO-Link operating mode	COM 2 (38.4 kBit/s)	COM 2 (38.4 kBit/s)
Supply voltage through IO-Link master	Yes	Yes
Inputs		
• Sensor supply, short-circuit resistant	Yes	Yes
• Current carrying capacity, sensor supply max.	mA 200	400
• Current carrying capacity of sockets 1 ... 4 total max.	mA 200	200
• Current carrying capacity of sockets 5 ... 8 total max.	mA --	200
• Input current at digital input with signal "1" min.	mA 11	11
• Input current at digital input with signal "0" max.	mA 1.5	1.5
• Input voltage at digital input with signal "1" min.	V 10	10
Socket assignment		
• Socket 1		
- Pin 1	Sensor supply L+	Sensor supply L+
- Pin 2	IN2	--
- Pin 3	Sensor supply L-	Sensor supply L-
- Pin 4	IN1	IN1
- Pin 5	--	--
• Socket 2		
- Pin 1	Sensor supply L+	Sensor supply L+
- Pin 2	IN4	--
- Pin 3	Sensor supply L-	Sensor supply L-
- Pin 4	IN3	IN2
- Pin 5	--	--
• Socket 3		
- Pin 1	--	Sensor supply L+
- Pin 3	--	Sensor supply L-
- Pin 4	--	IN3
• Socket 4		
- Pin 1	--	Sensor supply L+
- Pin 3	--	Sensor supply L-
- Pin 4	--	IN4
• Socket 5		
- Pin 1	--	Sensor supply L+
- Pin 3	--	Sensor supply L-
- Pin 4	--	IN5
• Socket 6		
- Pin 1	--	Sensor supply L+
- Pin 3	--	Sensor supply L-
- Pin 4	--	IN6
• Socket 7		
- Pin 1	--	Sensor supply L+
- Pin 3	--	Sensor supply L-
- Pin 4	--	IN7
• Socket 8		
- Pin 1	--	Sensor supply L+
- Pin 3	--	Sensor supply L-
- Pin 4	--	IN8
Parameters/diagnostics		
• Parameterizable input delay	Adjustable per module (1 ms, 3 ms, 15 ms, 20 ms)	
• Parameterizable inversion of the input signal	Adjustable per input	
• Diagnostic signals through IO-Link	Overload/short-circuit sensor supply	
Status displays		
• IO-Link communication indicator	Green/red dual LED	Green/red dual LED
• IO-Link device indicator	Green/red dual LED	Green/red dual LED
• Inputs/outputs indicator	Green LED per channel	Green LED per channel
Degree of protection	IP67	IP67
Approvals	CE (available) UL/CSA (submitted)	CE (available) UL/CSA (submitted)
Maximum cable length		
• Between master and I/O module	m 20	20
EMC properties		
• Immunity to electromagnetic interference acc. to IEC 60947-1	Environment A (industrial area)	Environment A (industrial area)
• Emitted electromagnetic interference acc. to IEC 60947-1	CISPR11, environment A (industrial area)	
Ambient temperature	°C -25 ... +70	-25 ... +70
Storage temperature	°C -40 ... +85	-40 ... +85
Mounting and dimensions		
• Type of mounting	Wall mounting on front or side	
• Dimensions W x H x D	mm 20 x 108 x 45	20 x 164 x 45

Dimensional drawings

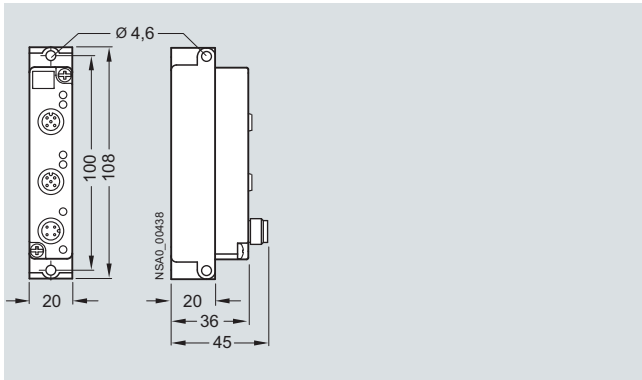

IO-Link K20 I/O module, 4 digital inputs, M12
(3RK5 010-0BA10-0AA0)

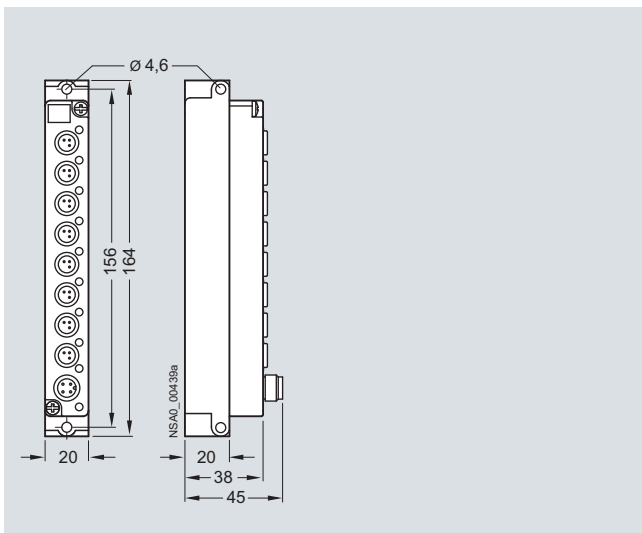

IO-Link K20 I/O module, 8 digital inputs, M8
(3RK5 010-0CA00-0AA0)

Schematics

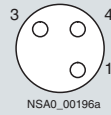

Pin 1: Supply L+
Pin 2: Supply L-
Pin 3: Input signal

Terminal assignment for input, M8 socket, standard assignment

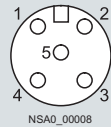

Pin 1: Supply L+
Pin 2: Input signal 2
Pin 3: Supply L-
Pin 4: Input signal 1
Pin 5: Not assigned

Terminal assignment for input, M12 socket, Y assignment

PROFIBUS

System Overview

Process or field communication

Overview

Communication functions

The process or field communication (PROFIBUS DP, PROFIBUS PA) is used to link field devices to an automation, HMI or I&C system.

The connection can be established through integrated interfaces on the CPU or using interface modules (IMs) and communications processors (CPs).

With today's powerful automation systems it is often more effective to link several PROFIBUS DP lines to one automation system not only in order to increase the number of connectable I/O stations but also to be able to handle individual production areas independently of others (segmentation).

PROFIBUS is standardized according to IEC 61158/EN 50170. It is an efficient, open and robust fieldbus system with short response times and the following protocols:

- PROFIBUS DP (Distributed Peripherals) is used to connect distributed peripherals, e. g. SIMATIC ET 200 with very fast response times according to the IEC 61158/EN 50170 standard.
- PROFIBUS PA (Process Automation) expands PROFIBUS DP with inherently safe transmission according to the international standard IEC 61158/IEC 61784.

PROFIBUS DP/PA is used to connect field devices such as distributed I/O stations or operating mechanisms to automation systems such as SIMATIC S7 or PCs.

PROFIBUS DP/PA is selected when I/O stations on a machine or in a plant (e. g. the field level) are widely distributed and can be spatially grouped to form a station (e. g. ET 200) (> 16 inputs/outputs).

In this case the actuators/sensors are connected to field devices, which are supplied with output data according to the master/slave principle and send the input data to the controller or the PC.

Powerful tools such as STEP 7 and COM PROFIBUS are available to configure and parameterize the I/O stations. With these tools, tests and start-ups are possible from every connection point using PROFIBUS DP.

DP device types

PROFIBUS DP differentiates between two different classes of master and various DP functionalities:

- DP master class 1
The DP master class 1 is the central component of PROFIBUS DP. In a fixed, continuously recurring message cycle the central controller or PC exchanges information with distributed stations (DP slaves).
- DP master class 2
Devices of this type (programming, configuring or operating devices) are used during start-up, for configuring the DP system or for operating the plant while it is running (diagnostics). A DP master class 2 is able, for example, to read the input data, output data, diagnostics data and configuration data of slaves.
- DP slave
A DP slave is an I/O station which reads in input information and sends out output information to the other peripherals. The amount of input and output information varies from device to device but is limited to a maximum 244 bytes per device. The functional scope of DP masters class 1 and 2 and of DP slaves can vary. A communications processor can be accordingly efficient and versatile.
- DP-V0
The DP master functions (DP-V0) are: Configuring, parameterizing, cyclic reading of input data and writing of outputs, and reading of diagnostics data.
- DP-V1
The additional DP function expansions (DP-V 1) enable acyclic read and write functions and alarm acknowledgment in parallel with the cyclic data traffic. These expanded DP functions also include acyclic access to the parameters and measured values of a slave (e. g. field devices of the process automation, intelligent operating and monitoring devices). Slaves of this type must be supplied with comprehensive parameter data during start-up and while running. The acyclically transmitted data (e. g. parameterizing data) are changed only rarely compared to the cyclic measured values and are transmitted with low priority in parallel with the fast cyclic transfer of useful data. Alarm acknowledgment on the master provides for the assured transmission of alarms from DP slaves.
- DP-V2
The DP master functions (DP-V2) are: cycle synchronization and cross data traffic between DP slaves.
- Cycle synchronization
Cycle synchronization is realized through the use of an equidistant cycle signal on the bus system. This cyclic, equidistant cycle is sent as a global control message frame from the master to all stations. Master and slaves can thus synchronize their applications on this signal. For typical drive applications it is necessary for the jitter of the cycle signal to be smaller than 1 µs.
- Cross data traffic between DP slaves
The publisher/subscriber model is used to implement the cross traffic between slaves. Slaves which are declared to be publishers make available their input data (equivalent to a reply message frame to their own master) to other slaves, the subscribers, for them to read as well. The cross traffic communication takes place cyclically.

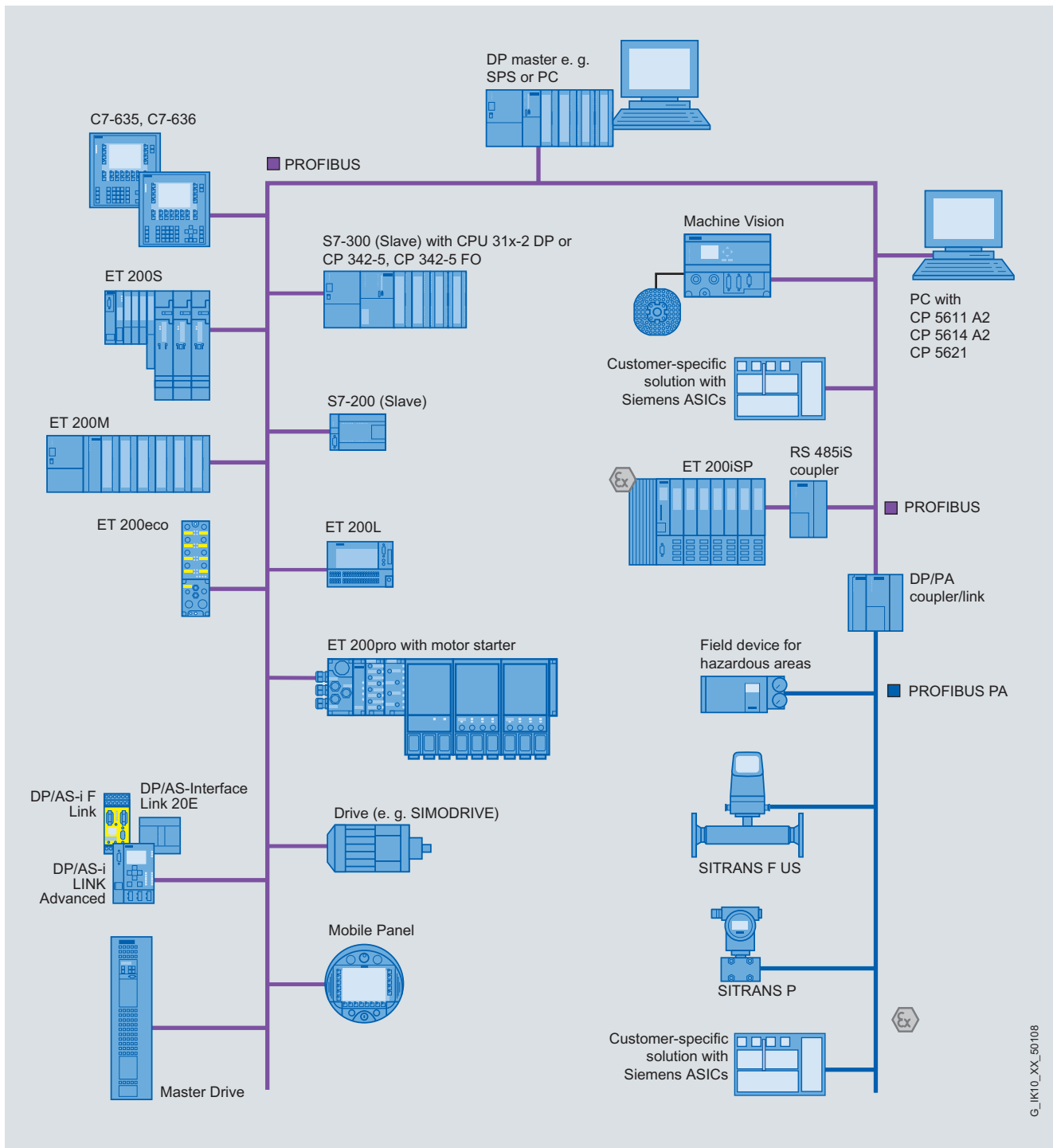

PROFIBUS DP slaves

PROFIBUS System Overview

Process or field communication

Integration

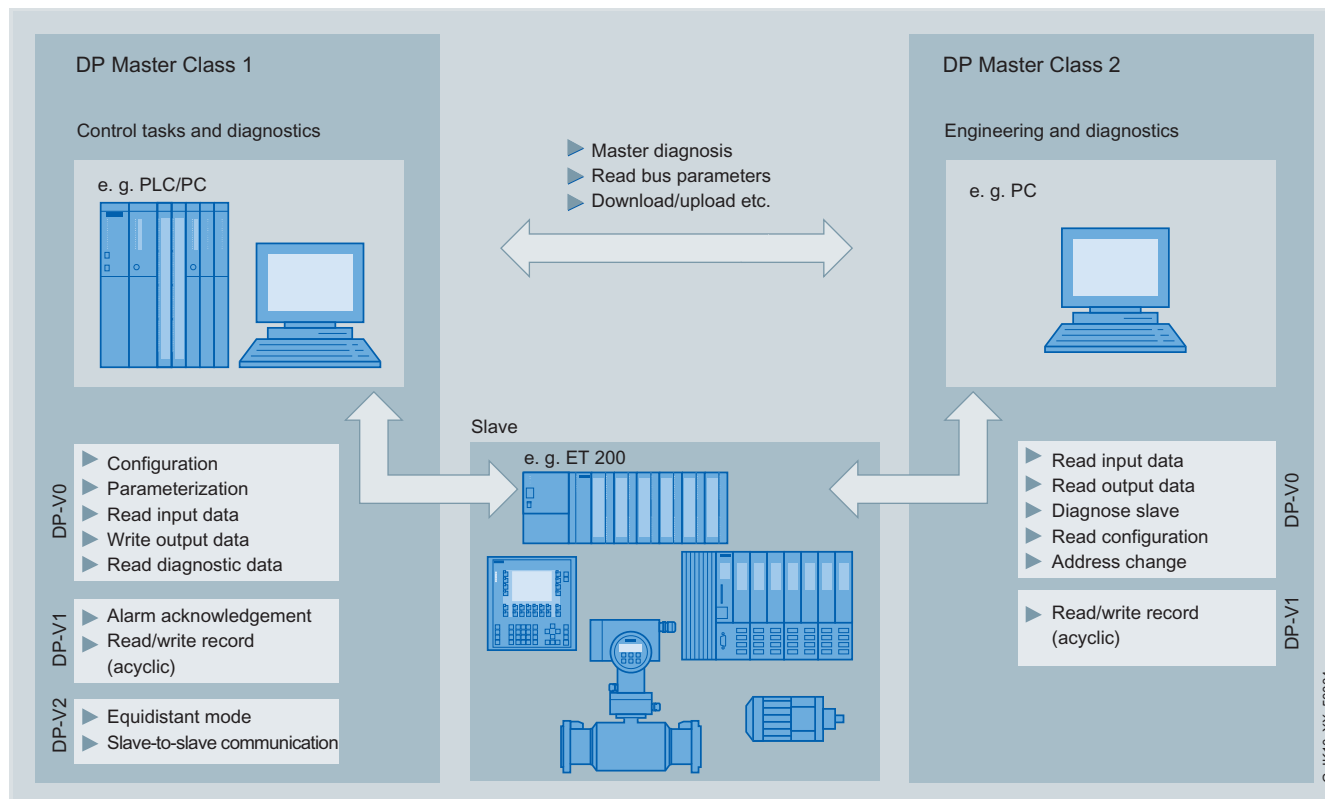

G..IK10..XX..50004

DP master classes

Function

	Hardware	PROFIBUS DP			PROFIBUS FMS			PG/OP	S7 communica- tion		Open commu- nication	Time	
		DP master Class 1	DP master Class 2	DP slave	Read	Write	Info. / Report		Standard system	High-availability communication		Send/Receive 1)	Sending stations
SIMATIC S7-300	CP 342-5/ CP 342-5 FO	• ²⁾		• ²⁾				•	•		•		
	CP 343-5				•	•	•	•	• ³⁾		•		
SIMATIC S7-400	CP 443-5 Extended	•	•					•	•	•	•	•	•
	CP 443-5 Basic				•	•	•	•	•		•	•	•

1) SDA and SDN services of PROFIBUS Layer 2 (FDL)
 2) DP master or DP slave
 3) S7 server only

• suitable
 not applicable







G_IK10_XX_50100

Communication overview for SIMATIC

PROFIBUS System Overview

Communication overview

2

Hardware	Software	Operation system (32 Bit)					OPC ⁶⁾	PROFIBUS DP			PROFIBUS FMS			PG/OP	S7 communication	Open communication ⁸⁾
		Windows XP Pro	Windows 2003 Server / 2003 R2 Server	Windows Vista Business / Ultimate	other operating systems			DP Master Class 1	DP Master Class 2	DP slave	Read	Write	Info/Report			
CP 5613 A2	CP with DP Base ^{1) 4)}	•	•	•		•	•	•	• ⁵⁾				•		•	
CP 5613 FO	DP-5613 ⁴⁾	 •	•	•		•	•	•					•		•	
CP 5614 A2 (PCI 32 Bit)	S7-5613	 •	•	•		•							•		•	
	FMS-5613	 •	•	•		•				•	•	•	•	•	•	
	DK-5613	• ⁷⁾	• ⁷⁾	• ⁷⁾	• ⁷⁾		•		• ⁵⁾							
CP 5611 A2 (PCI 32 Bit)	SOFTNET-DP 	•	•	•		•	• ²⁾³⁾	• ²⁾³⁾							•	
CP 5621 (PCIe x1)	SOFTNET-DP Slave 	•	•	•		•			• ²⁾							
CP 5512 (CardBus 32 Bit)	SOFTNET-S7 	•	•	•		•							•	•	•	
	STEP 7	•	•	•									•			

You can find more information on the Internet <http://www.siemens.com/simatic-net/ik-info>
If you have questions on LINUX projects please contact I&S
E-mail: it4industry@siemens.com

- 1) Included in scope of supply of the CP 5613/A2/CP 5613FO/CP 5614 A2
- 2) DP master and DP slaves cannot be operated simultaneously
- 3) Master Class 1 and Master Class 2 cannot be operated simultaneously on one CP
- 4) DP-Base and DP-5613 cannot be operated simultaneously
- 5) only with CP 5614
- 6) incl. XML DA interface for data access
- 7) with porting via DK-5613
- 8) SEND/RECEIVE based on the FDL interface

 on SIMATIC NET-CD Edition 2007

 suitable
 not applicable

G_IK10_XX_50058

Communication overview for PG/PC

Integration

Configuration example for process or field communication

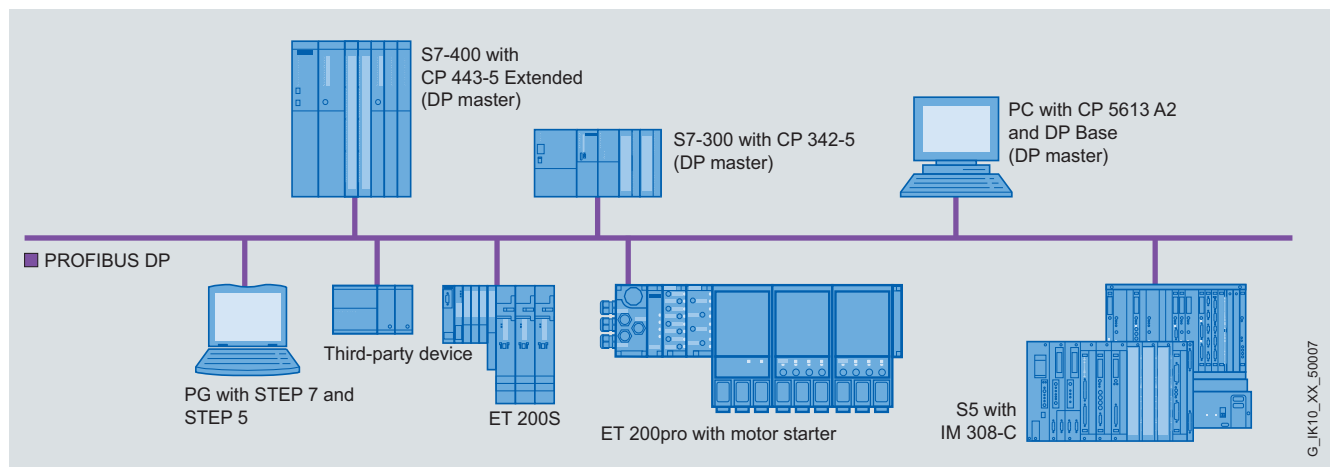

PROFIBUS DP configuration for SIMATIC S5/S7 and PG/PC

Configuration example for data communication

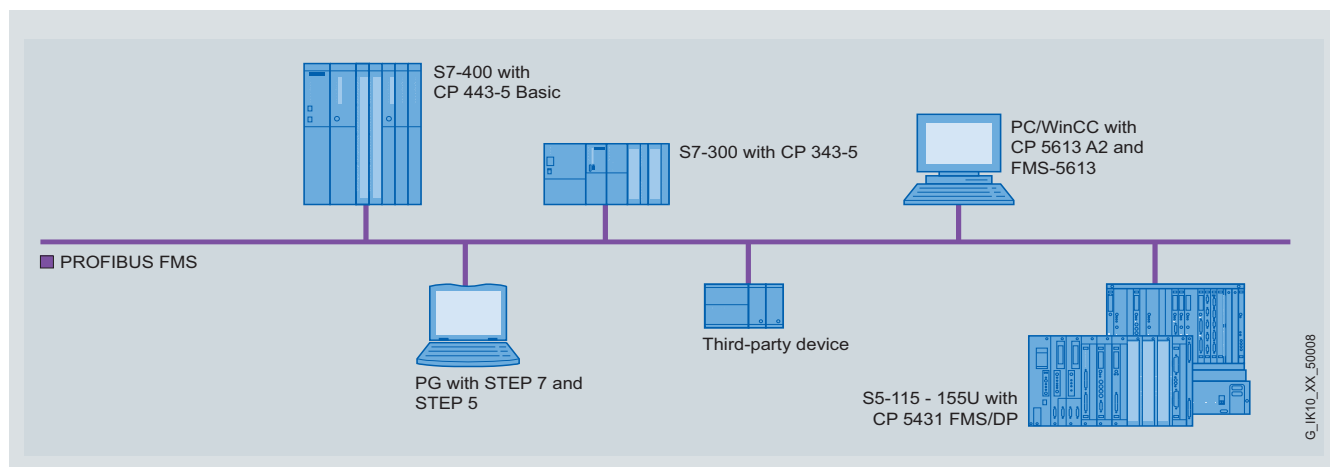

PROFIBUS FMS configuration for SIMATIC S5/S7 and PG/PC

PROFIBUS System Overview

Configuration examples

Configuration example for PG/OP communication

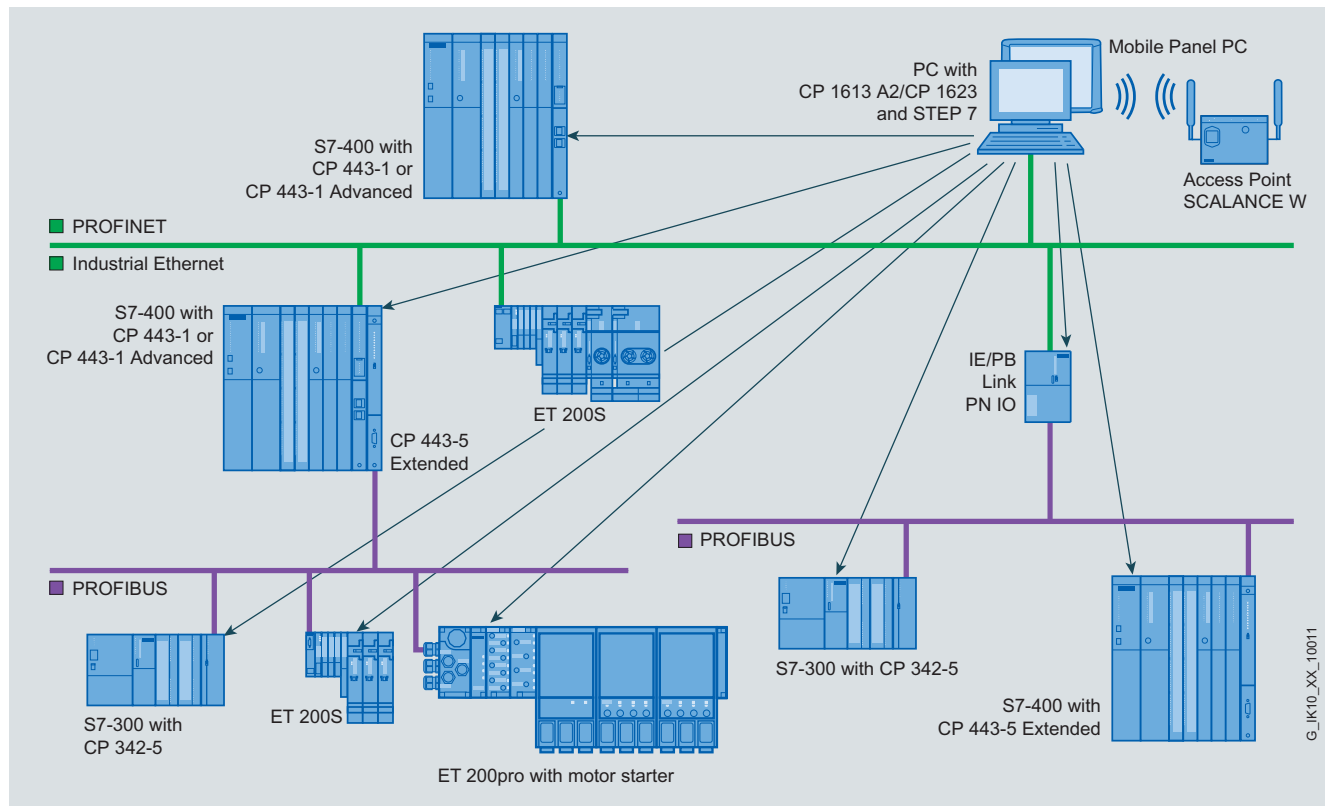

PG/OP communication with S7 routing

Technical specifications

Standard	PROFIBUS acc. to IEC 61158/EN 50170 Volume 2	
Topology	<ul style="list-style-type: none"> • Electrical network: Bus, tree • Optical network: Bus, tree, ring • Wireless coupling: Point-to-point, point-to-multipoint 	
Transmission medium	<ul style="list-style-type: none"> • Electrical network: Shielded two-conductor cable • Optical network: Optical conductor (glass, PCF and plastic) • Wireless coupling: Infrared 	
Network size	<ul style="list-style-type: none"> • Electrical network: km Max. 9.6 • Optical network: km Max. 90 • Wireless coupling: m Max. 15 	
Transmission rate	9.6 kbit/s to 12 Mbit/s (adjustable) including 31.25 kbit/s for PROFIBUS PA	
Number of stations	Max. 127	
Access control	Token passing with lower-level master-slave	
Protocols	PROFIBUS DP PG/OP communication S7 communication S5 compatible communication (SEND/RECEIVE) PROFIBUS FMS	

More information

For the SIMATIC NET products referred to above (order numbers 6GK..., 6XV1...) please also note the conditions of application, which can be consulted on the Internet site quoted below.

You can find more information on the Internet at:

<http://www.siemens.com/simatic-net/ik-info>

More information about PROFIBUS can be found in Catalog IK PI, in the chapter *PROFIBUS according to IEC 61158 / EN 50170*.

SIRIUS Modular System

System overview

Overview

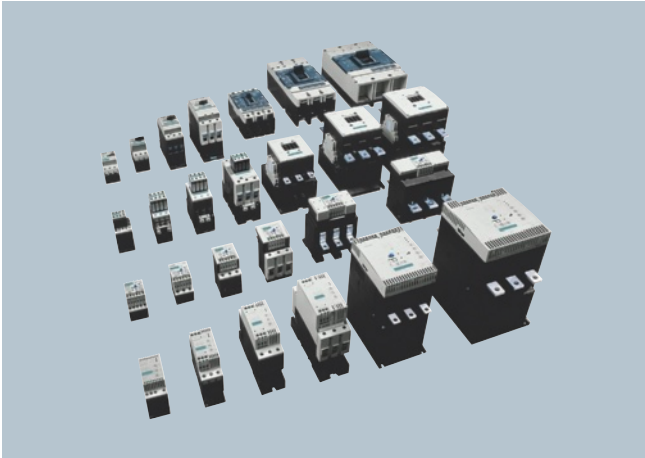

A perfect team: the SIRIUS modular system for the control cabinet

Building control cabinets should be quick, easy, flexible and space-saving. But how can all these requirements be met simultaneously? The answer lies in the unique SIRIUS modular system, where you will find everything that you need for switching, protecting and starting motors and industrial systems.

This modular selection of standard components covers the range up to 250 kW / 400 V in just seven sizes which are optimally coordinated, can be combined with ease and use the same accessories. Control technology can be that simple.

Continuous further development and regular innovations ensure that our customers are optimally equipped with SIRIUS and benefit from efficient solutions - today and tomorrow.

All components of the SIRIUS modular system are characterized by a space-saving design and high flexibility. Configuring, installing, wiring and maintenance are extremely easy and time-saving to perform.

Regardless of whether you want to build up load feeders with motor starter protectors/circuit breakers or overload relays, contactors or soft starters, SIRIUS has the right product for every application.

The new 3RV17 and 3RV18 circuit breakers

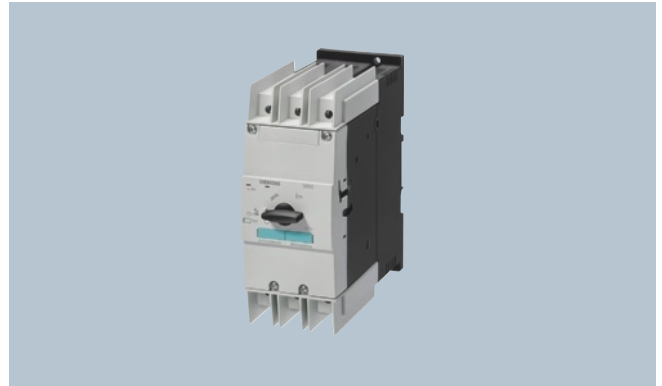

The newly developed 3RV17 (size S0, S3) and 3RV18 (size S0) circuit breakers are approved as "Circuit Breakers" according to UL 489 and CSA C22.2 No. 5-02.

This means that devices of the 3RV series can now be used also in North America to protect plants and non-motor loads such as transformers. For such applications it was necessary up to now to use MCCBs or fuses.

The new 3RV17/3RV18 circuit breakers are available for currents from 0.16 A to 70 A. They extend the service-proven 3RV product range and are coordinated with the dimensions of the other components in the SIRIUS modular system.

With the 3RV17 and 3RV18, the uniform configuring of IEC and UL/CSA control cabinets is now possible.

SIRIUS stands for innovation

To be able to meet our customers' requirements tomorrow as well as today we are dedicated to the ongoing development of our product portfolio.

The new SIRIUS 3RW40 soft starters – for soft starting up to high ratings



Two new types of soft starter in compact SIRIUS design provide the answer for the starting of three-phase asynchronous motors with reduced strain on the load and the network. The new SIRIUS 3RW40 soft starter is used in demanding standard applications. The SIRIUS 3RW44 soft starter is the right choice for high functionality and for difficult starting operations.

For simple to demanding standard applications in which a wye-delta starter has been used up to now, the SIRIUS 3RW40 soft starter provides the best solution for starting applications with zero torque surge. With a power range up to 250 kW (at 400 V) the new SIRIUS 3RW40 soft starters supplement the service-proven soft starter product range. The new 3RW30 soft starters with their basic functions round off the bottom end of the existing product range.

The use of 2-phase controlled soft starters up to this high performance range is unique and was made possible by a new control method which was specially developed by Siemens.

For motor starts with more exacting requirements, which up to now had to be implemented with a frequency converter for example, the SIRIUS 3RW44 soft starter provides the greatest functionality and diagnostics with user-friendly operation. For integration in the process landscape the new 3RW44 high-feature soft starter can be retrofitted with an optional PROFIBUS DP module. Thanks to its new torque control the SIRIUS 3RW44 soft starter is a master of difficult starting and ramp-down operations for operating mechanisms covering a performance range up to 710 kW at 400 V with an inline circuit (up to 1200 kW at 400 V with an inside-delta circuit).

SIRIUS Modular System

System overview

Design

2

S00	S0	S2	S3	S6	S10	S12
						
SIRIUS 3RV motor starter protectors				SENTRON		
						
SIRIUS 3RT contactors						
						
SIRIUS 3RU/3RB overload relays						
						
SIRIUS 3RW soft starters						

The seven compact sizes of the modular system

NSAQ_00418b

More information

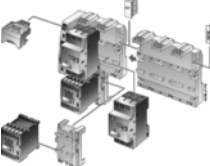
Product	For further information see
<p>Robust and reliable: SIRIUS 3RT contactors</p>  <p>Thanks to the extreme robustness and best contact reliability of our contactors, their switching is extremely precise and reliable. At the same time they enable you to build compact control cabinets with a high packing density because the auxiliary switch blocks and coil circuits are inside the contactor's contours. This facilitates expansions and saves a great deal of space in the control cabinet.</p>	<ul style="list-style-type: none"> • Our Mall: <ul style="list-style-type: none"> - Section "Low-Voltage Controls" --> "SIRIUS Industrial Controls" --> "Controls" --> "Contactors and Contactor Assemblies" • Catalog: <ul style="list-style-type: none"> - Section "Controls" --> "Contactors and Contactor Assemblies"
<p>Much more than ON/OFF: the SIRIUS 3RV motor starter protectors</p>  <p>The SIRIUS 3RV motor starter protectors are compact, current limiting circuit breakers. They ensure reliable shutdown in the short-circuit case and protect loads and the system from overloads. In addition they are suitable for normal switching duty with loads that have a small number of switching operations as well as for reliable isolation of the equipment from the supply system for maintenance work or modifications.</p>	<ul style="list-style-type: none"> • Our Mall: <ul style="list-style-type: none"> - Section "Low-Voltage Controls" --> "SIRIUS Industrial Controls" --> "Protection Equipment" --> "Motor Starter Protectors up to 100 A" • Catalog: <ul style="list-style-type: none"> - Section "Protection Equipment"
<p>Triggering when things get serious: SIRIUS 3RU and 3RB overload relays</p>  <p>The overload relays of the SIRIUS family are available in a thermal version as well as in a solid-state version for high-feature applications. They are responsible in the main circuit for the inverse-time delayed overload protection of loads and the other switching and protective devices in the respective load feeder.</p>	<ul style="list-style-type: none"> • Our Mall: <ul style="list-style-type: none"> - Section "Low-Voltage Controls" --> "SIRIUS Industrial Controls" --> "Protection Equipment" --> "Overload Relays" • Catalog: <ul style="list-style-type: none"> - Section "Protection Equipment"
<p>Soft starting and ramp-down: SIRIUS 3RW soft starters</p>  <p>The 3RW soft starters offer a complete range covering all standard and high-feature motor starting applications. As the result, the advantages of soft starting and ramp-down can be used today in a wide range of applications for realizing optimum machine concepts with greater ease and lower cost.</p>	<ul style="list-style-type: none"> • Our Mall: <ul style="list-style-type: none"> - Section "Low-Voltage Controls" --> "SIRIUS Industrial Controls" --> "Load Feeders, Motor Starters and Soft Starters" --> "3RW Soft Starters" • Catalog: <ul style="list-style-type: none"> - Section "Load Feeders, Motor Starters and Soft Starters"
<p>Everything ready for immediate use: with factory-wired SIRIUS load feeders</p>  <p>Load feeders start loads by means of a combination of switching and protection functions. This requires a wide selection of different components in order to be able to realize all starter types. To keep downtimes as short as possible, Siemens offers factory-wired starter solutions.</p>	<ul style="list-style-type: none"> • Our Mall: <ul style="list-style-type: none"> - Section "Low-Voltage Controls" --> "SIRIUS Industrial Controls" --> "Load Feeders, Motor Starters and Soft Starters" • Catalog: <ul style="list-style-type: none"> - Section "Load Feeders, Motor Starters and Soft Starters"
<p>SIRIUS infeed system</p>  <p>When you want to supply current to several circuit breakers in a group or to complete load feeders, all arguments are in favor of using the user-friendly SIRIUS infeed system. Thanks to a terminal block it is also possible to integrate single-pole, two-pole or three-pole components.</p>	<ul style="list-style-type: none"> • Our Mall: <ul style="list-style-type: none"> - Section "Low-Voltage Controls" --> "SIRIUS Industrial Controls" --> "Load Feeders, Motor Starters and Soft Starters" --> "3RA Fuseless Load Feeders" • Catalog: <ul style="list-style-type: none"> - Section "Load Feeders, Motor Starters and Soft Starters"

SIRIUS Modular System

Notes

2



Controls – Contactors and Contactor Assemblies

3



3/2	Introduction	
	3RT, 3TB, 3TF Contactors for Switching Motors	
3/5	General data	
3/11	3RT10 contactors, 3-pole, 3 ... 250 kW	3/130
3/55	3RT12 vacuum contactors, 3-pole, 110 ... 250 kW	3/136
3/64	3TF6 vacuum contactors, 3-pole, 335 ... 450 kW	3/137
3/71	3TB5 contactors with DC solenoid system, 3-pole, 55 ... 200 kW	3/141
3/76	3TF2 contactors, 3-pole, 2.2 ... 4 kW	3/145
	3RA13, 3RA14 Contactor Assemblies	
	<u>3RA13 Reversing Contactor Assemblies</u>	
3/84	3RA13 complete units, 3 ... 45 kW	3/148
	<u>3RA14 Contactor Assemblies for Wye-Delta Starting</u>	3/152
3/86	3RA14 complete units, 3 ... 75 kW	3/153
	3TD, 3TE Contactor Assemblies	
3/90	3TD6 reversing contactor assemblies, 335 kW	3/157
3/91	3TE6 contactor assemblies for wye-delta starting, 630 kW	
	3RT, 3RH, 3TB, 3TC, 3TH, 3TK Contactors for Special Applications	
	<u>3RT14 Contactors for Switching Resistive Loads (AC-1)</u>	
3/93	3-pole, 140 ... 690 A	3/164
	<u>3RT13 Contactors for Switching Resistive Loads (AC-1)</u>	
3/102	4-pole, 4 NO, 18 ... 140 A	3/164
	<u>3TK1 Contactors for Switching Resistive Loads (AC-1)</u>	
3/106	4-pole, 4 NO, 200 ... 1000 A	3/164
	<u>3TK20 Contactors</u>	
3/109	4-pole, 4 kW	3/164
	<u>3RT15 Contactors</u>	
3/116	4-pole, 2 NO + 2 NC, 4 ... 18.5 kW	3/164
	<u>3RT16 Capacitor Contactors</u>	
3/118	12.5 ... 50 kvar	3/164
	<u>Contactors with Extended Operating Range $0.7 \dots 1.25 \times U_{s2}$ for Railway Applications</u>	
3/120	3RH11 contactor relays	3/178
3/121	3TH4 contactor relays	3/179
3/122	3RT10 motor contactors, 5.5 ... 45 kW	3/221
3/124	3TB5 motor contactors, 55 ... 200 kW	
3/125	3TC contactors for switching DC voltage, 2-pole	
	<u>3TC Contactors for Switching DC Voltage</u>	
3/126	1- and 2-pole, 32 ... 400 A	
	3RH, 3TH Contactor Relays	
3/130	3RH1 contactor relays, 4- and 8-pole	
3/136	3RH14 latched contactor relays, 4-pole	
3/137	3TH4 contactor relays, 8- and 10-pole	
3/141	3TH2 contactor relays, 4- and 8-pole	
3/145	3RH11 coupling relays for switching auxiliary circuits, 4-pole	
	3RT Coupling Relays	
3/146	3RT10 coupling relays (interface), 3-pole, 3 ... 11 kW	
	3TX7, 3RS18 Coupling Relays	
	<u>3TX7 Coupling Relays, Narrow Design</u>	
3/148	Relay couplers	
3/152	Relay couplers with plug-in design	
3/153	Semiconductor couplers	
	<u>3RS18 Coupling Relays with Industrial Housing</u>	
3/157	Relay couplers	
	Coupling Relays with LZS/LZX Plug-In Relays	
3/160	Plug-in relay couplers	
	3TG10 Power Relays/Miniature Contactors	
3/164	4-pole, 4 kW	
	Accessories and Spare Parts	
	<u>For 3RT, 3RH Contactors and Contactor Relays</u>	
3/167	Accessories for 3RT, 3RH contactors and contactor relays	
	<u>For 3T Contactors and Contactor Relays</u>	
3/176	Accessories for 3TB, 3TC, 3TF, 3TG, 3TK contactors	
3/177	Accessories for 3TH contactor relays	
	Project Planning Aids	
3/178	- Overview	
3/179	- Dimensional drawings	
3/221	- Schematics	

Controls – Contactors and Contactor Assemblies

Introduction

Overview



Size	S00				S0					S2	
Type	3RT10 1				3RT10 2					3RT10 3	

3RT10 contactors • 3RT12 and 3TF68/69 vacuum contactors

Type AC, DC operation	3RT10 15	3RT10 16	3RT10 17	3RT10 23	3RT10 24	3RT10 25	3RT10 26	3RT10 34	3RT10 35	3RT10 36
Type	--	--	--	--	--	--	--	--	--	--

AC-3

$I_e/AC-3/400\text{ V}$	A	7	9	12	9	12	17	25	32	40	50
400 V	kW	3	4	5.5	4	5.5	7.5	11	15	18.5	22
230 V	kW	2.2	3	3	3	3	4	5.5	7.5	11	15
500 V	kW	3.5	4.5	5.5	4.5	7.5	10	11	18.5	22	30
690 V	3RT10/12 kW	4	5.5	5.5	5.5	7.5	11	11	18.5	22	22
1000 V	3RT10/12 kW	--	--	--	--	--	--	--	--	--	--

AC-4 (for $I_a = 6 \times I_e$)

400 V	kW	3	4	4	4	5.5	7.5	7.5	15	18.5	22
400 V	3RT10/12 kW (200 000 operating cycles)	1.15	2	2	2	2.6	3.5	4.4	8.2	9.5	12.6

AC-1 (40 °C, ≤ 690 V)

I_e	3RT10/12 A	18	22	22	40	40	40	40	50	60	60
-------	------------	-----------	-----------	-----------	-----------	-----------	-----------	-----------	-----------	-----------	-----------

3RT14 AC-1 contactors

Type	--	--	--
$I_e/AC-1/40\text{ °C}/\leq 690\text{ V}$	A	--	--

Accessories for contactors

Auxiliary switch blocks front lateral	3RH19 11	3RH19 21	3RH19 21
	--	3RH19 21	3RH19 21
Terminal covers	--	--	3RT19 36-4EA2
Box terminal blocks	--	--	--
Surge suppressors	3RT19 16	3RT19 26	3RT19 26/36

3RU11 and 3RB20/21 overload relays (protection equipment: overload relays)

3RU11 , thermal, CLASS 10	3RU11 16	0.1 ... 12 A	3RU11 26	1.8 ... 25 A	3RU11 36	5.5 ... 50 A
3RB20/21 , solid-state, CLASS 5, 10, 20 and 30	3RB20 16	0.1 ... 12 A	3RB20 26	3 ... 25 A	3RB20 36	6 ... 50 A
	3RB21 16		3RB21 26		3RB21 36	
3RB22/23 , solid-state, CLASS 5, 10, 20 and 30	3RB2. 83 + 3RB29 06	0.3 ... 25 A			3RB2. 83 + 3RB29 06	10 ... 100 A

3RV10 motor starter protectors (protection equipment: motor starter protectors)

Type	3RV10 11	0.18 ... 12 A	3RV10 21	9 ... 25 A	3RV10 31	22 ... 50 A
Link modules	3RA19 11		3RA19 21		3RA19 31	

3RA13 reversing contactor assemblies

Complete units Type	3RA13 15	3RA13 16	3RA13 17	3RA13 24	3RA13 25	3RA13 26	3RA13 34	3RA13 35	3RA13 36
400 V kW	3	4	5.5	5.5	7.5	11	15	18.5	22
Assembly kits/wiring modules	3RA19 13-2A			3RA19 23-2A			3RA19 33-2A		
Mechanical interlocks	3RA19 12-2H			3RA19 24-1A/-2B					

3RA14 contactor assemblies for wye-delta starting

Complete units Type	3RA14 15	3RA14 16	3RA14 23	3RA14 25	3RA14 34	3RA14 35	3RA14 36
400 V kW	5.5	7.5	11	15/18.5	22/30	37	45
Assembly kits/wiring modules	3RA19 13-2B		3RA19 23-2B		3RA19 33-2B/-2C		

Note:

For safety characteristics for contactors see LV 1 2009 "Appendix" -> "Standards and approvals" -> "Overview".



S3
3RT1. 4



S6
3RT1. 5



S10
3RT1. 6



S12
3RT1. 7



S14
3TF6

	3RT10 44	3RT10 45	3RT10 46	3RT10 54	3RT10 55	3RT10 56	3RT10 64	3RT10 65	3RT10 66	3RT10 75	3RT10 76	--	
	--			--			3RT12 64	3RT12 65	3RT12 66	3RT12 75	3RT12 76	3TF68	3TF69
	65	80	95	115	150	185	225	265	300	400	500	630	820
	30	37	45	55	75	90	110	132	160	200	250	335	450
	18.5	22	22	37	45	55	55	75	90	132	160	200	260
	37	45	55	75	90	110	160	160	200	250	355	434	600
	45	55	55	110	132	160	200	250	250	400	400/500	600	800
	30	37	37	75	90	90	90/315	132/355	132/400	250/560	250/710	600	800
	30	37	45	55	75	90	110	132	160	200	250	355	400
	15.1	17.9	22	29	38	45	54/78	66/93	71/112	84/140	98/161	168	191
	100	120	120	160	185	215	275/330	330	330	430/610	610	700	910
	3RT14 46			3RT14 56			3RT14 66			3RT14 76		--	
	140			275			400			690		--	
	--			--			--			--		--	
	--			--			--			--		--	
	3RT19 46-4EA1/2			3RT19 56-4EA1/2/3			3RT19 66-4EA1/2/3			3TY7 561			
	--			3RT19 55/56-4G			3RT19 66-4G			3TX7 686/696			
	--			3RT19 56-1C (RC element)			--			--			
	--			--			--			3TX7 572			
	3RU11 46	18 ... 100 A		--			--			--		--	
	3RB20 46	12.5 ... 100 A		3RB20 56 50 ... 200 A			3RB20 66 55 ... 630 A			3RB20 66 160 ... 630 A		3RB20 66 160 ... 630 A	
	3RB21 46	--		3RB21 56			3RB21 66			3RB21 66		3RB21 66	
	--			3RB2. 83 + 3RB29 56 20 ... 200 A			3RB2. 83 + 3RB29 66 63 ... 630 A			--			
	3RV10 41	45 ... 100 A		--			--			--		--	
	3RA19 41	--		--			--			--		--	
	3RA13 44	3RA13 45	3RA13 46	--			--			--		3TD68 04	
	30	37	45	55	75	90	110	132	160	200	250	335	335
	3RA19 43-2A			3RA19 53-2A			3RA19 63-2A			3RA19 73-2A		3TX7 680-1A	
	--			3RA19 54-2A			--			--		3TX7 686-1A	
	3RA14 44	3RA14 45		--			--			--		3TE68 04	
	55	75		--			--			--		630	
	3RA19 43-2B/-2C			3RA19 53-2B			3RA19 63-2B			3RA19 73-2B		3TX7 680-1B	

Introduction

The advantages at a glance



3TX7



3RS18



LZS/LZX



3TG10

		Order No.	Page
Coupling links, narrow design			
Relay couplers	<ul style="list-style-type: none"> Width 6.2 mm (1 NO, 1 CO), 12.5 mm and 17.5 mm Output coupling links Input coupling links with hard gold-plating 	3TX7 002, 3TX7 003, 3TX7 004, 3TX7 005	3/148
Plug-in base couplers, complete with relay	<ul style="list-style-type: none"> Width 6.2 mm (1 NO, 1 CO) Relays, replaceable 	3TX7 014-1..00	3/152
Plug-in base couplers, complete with relay and hard gold-plating	<ul style="list-style-type: none"> Width 6.2 mm (1 CO) 	3TX7 014-1..02	3/152
Semiconductor couplers	<ul style="list-style-type: none"> Output 1 semiconductor, triac or transistor 	3TX7 002, 3TX7 004, 3TX7 005	3/152
Coupling relays in industrial housing			
Relay couplers	<ul style="list-style-type: none"> Protective separation up to 300 V between contacts and relay circuits 1, 2 and 3 changeover contacts Hard gold-plated contacts in combination and wide voltage range versions 	3RS18	3/157
Coupling relays with plug-in relays			
Plug-in relay couplers with 2, 3 and 4 changeover contacts	<ul style="list-style-type: none"> Switching capacity 12 A/10 A/6 A Width 27 mm Base optionally with or without logical isolation 	LZS/LZX:PT	3/160
Plug-in relay couplers with 1, 2 changeover contacts	<ul style="list-style-type: none"> Switching capacity 16 A/8 A Width 15.5 mm Base optionally with or without logical isolation 	LZS/LZX:RT	3/160
Plug-in relay couplers with 3 changeover contacts and circular base	<ul style="list-style-type: none"> Switching capacity 6 A 11-pole circular base Width 38 mm 	LZS/LZX:MT	3/160
Power relays			
With screw and flat connectors		3TG10	3/164

Connection method

The contactors and relays are available with screw terminals (box terminals and connecting bars) or with Cage Clamp terminals or spring-type terminals or with plug-type connectors. Some device types are also available with solder pin connections.



Screw terminals



Cage Clamp terminals or spring-type terminals



Flat connectors



Plug-in terminals



Solder pin connections

These connections are indicated in the Technical specifications by orange backgrounds.

Overview

3RT1 contactors and coupling relays
Size S00 with mountable accessories

The SIRIUS generation of controls is a complete, modular system family, logically designed right down to the last detail, from the basic units to the accessories.

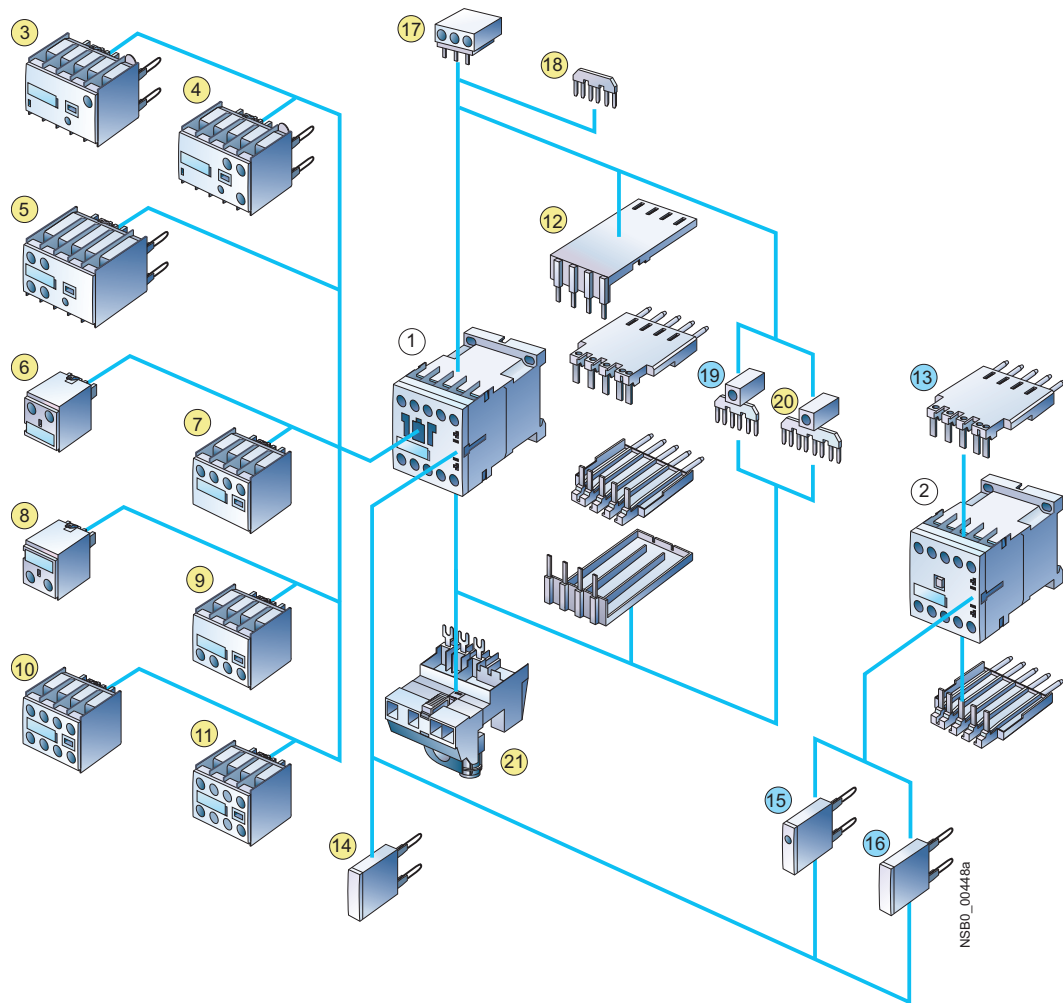

- ① Contactor
- ② Coupling relay

- ③ Solid-state timing relay block, with ON-delay
- ④ Solid-state timing relay block, with OFF-delay
- ⑤ Auxiliary switch block with solid-state time delay (ON or OFF-delay or wye-delta function)
- ⑥ 1-pole auxiliary switch block, cable entry from above
- ⑦ 2-pole auxiliary switch block, cable entry from above
- ⑧ 1-pole auxiliary switch block, cable entry from below
- ⑨ 2-pole auxiliary switch block, cable entry from below
- ⑩ 4-pole auxiliary switch block (terminal designations according to EN 50012 or EN 50005)
- ⑪ 2-pole auxiliary switch block, standard version or solid-state compatible version (terminal designations according to EN 50005)
- ⑫ Solder pin adapter for contactors with 4-pole auxiliary switch block
- ⑬ Solder pin adapter for contactors and coupling relays

- ⑭ Additional load module for increasing the permissible residual current
- ⑮ Surge suppressor with LED
- ⑯ Surge suppressor without LED
- ⑰ 3-phase feeder terminal
- ⑱ Link for paralleling (star jumper), 3-pole, without connection terminal
- ⑲ Link for paralleling, 3-pole, with terminal
- ⑳ Link for paralleling, 4-pole, with terminal
- ㉑ Connection module (adapter and connector) for contactors with screw-type connection

- For contactors
- For contactors and coupling relays (interface)

For contactor assemblies see pages 3/84 to 3/85.
 For assembly kit for reversing contactor assemblies (mech. interlocking, wiring modules) see Catalog LV 1.
 For mountable overload relays see "Protection Equipment --> Overload Relays".

For fuseless load feeders, see "Load Feeders, Motor Starters and Soft Starters -> 3RA Fuseless Load Feeders".

3RT, 3TB, 3TF Contactors for Switching Motors

General data

3RT1 contactors

Sizes S0 to S3 with mountable accessories

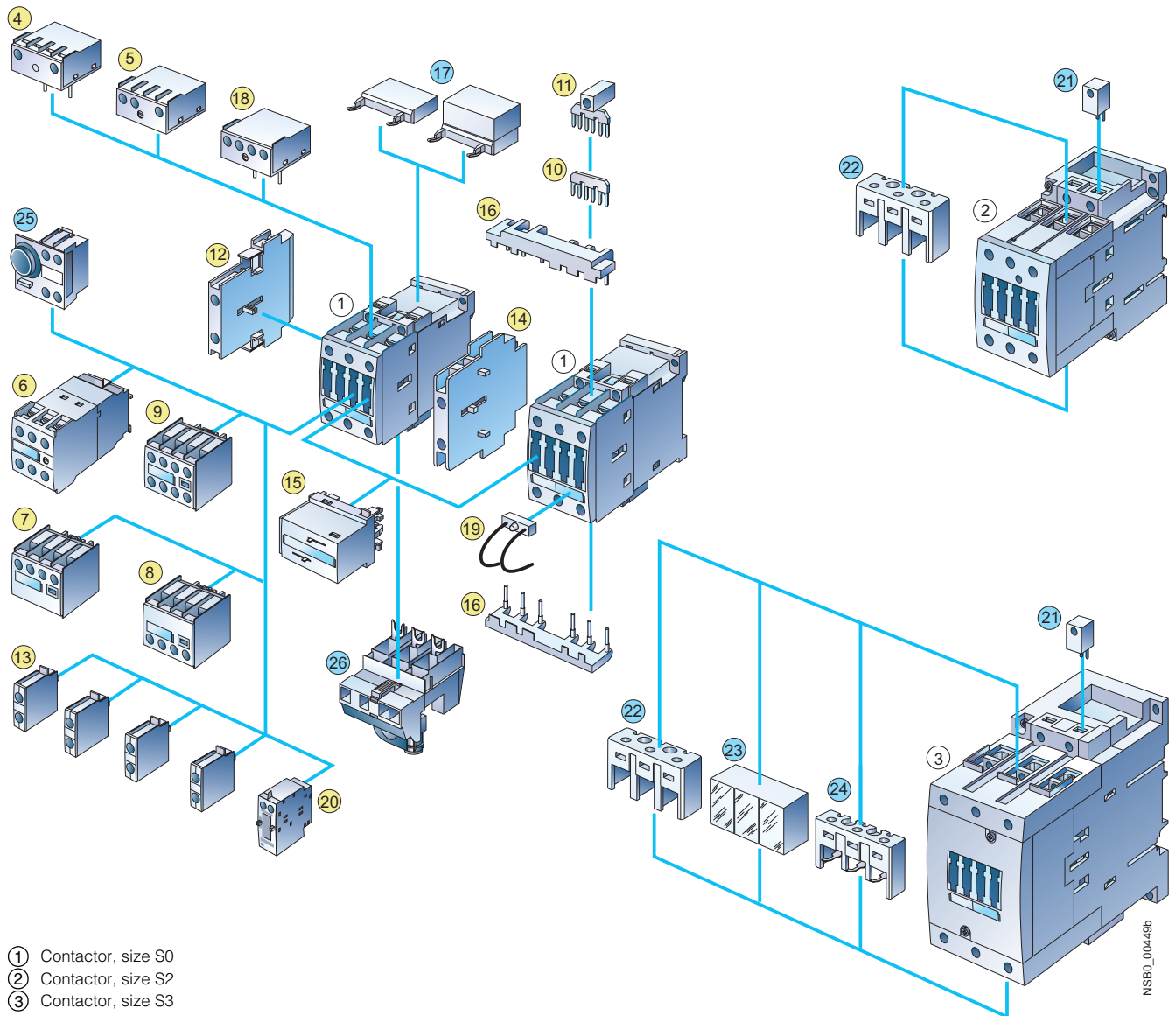

- ① Contactor, size S0
- ② Contactor, size S2
- ③ Contactor, size S3

For sizes S0 to S3:

- ④ Solid-state timing relay block, with ON-delay
- ⑤ Solid-state timing relay block, with OFF-delay
- ⑥ Auxiliary switch block with solid-state time delay (ON or OFF-delay or wye-delta function)
- ⑦ 2-pole auxiliary switch block, cable entry from above
- ⑧ 2-pole auxiliary switch block, cable entry from below
- ⑨ 4-pole auxiliary switch block (terminal designations according to EN 50012 or EN 50005)
- ⑩ Link for paralleling (star jumper), 3-pole, without connection terminal
- ⑪ Link for paralleling, 3-pole, with terminal
- ⑫ 2-pole auxiliary switch block, laterally mountable left or right (terminal designations according to EN 50012 or EN 50005)
- ⑬ Single-pole auxiliary switch block (up to 4 can be snapped on)
- ⑭ Mechanical interlock, laterally mountable
- ⑮ Mechanical interlock, mountable on the front
- ⑯ Wiring module on the top and bottom (reversing duty)
- ⑰ Surge suppressor (varistor, RC element, diode assembly), can be mounted on the top or bottom (different for S0 and S2/S3)

- ⑱ Coupling link for mounting directly onto contactor coil
- ⑲ LED module for indicating contactor operation

Only for size S0:

- ⑳ Pneumatic delay block
- ㉑ Connection module (adapter and connector) for contactors with screw-type connection

Only for sizes S0 and S2:

- ㉒ Mechanical latching

Only for sizes S2 and S3:

- ㉓ Coil repeat terminal for making contactor assemblies
- ㉔ Terminal cover for box terminals

Only for size S3:

- ㉕ Terminal cover for cable lugs and busbar connections
- ㉖ Auxiliary terminal, 3-pole

- Accessories identical for sizes S0 to S3
- Accessories differ according to size

NSB0_00449b

3RT, 3TB, 3TF Contactors for Switching Motors

General data

3RT1 contactors
Sizes S6 to S12 with accessories
(illustration for basic unit)

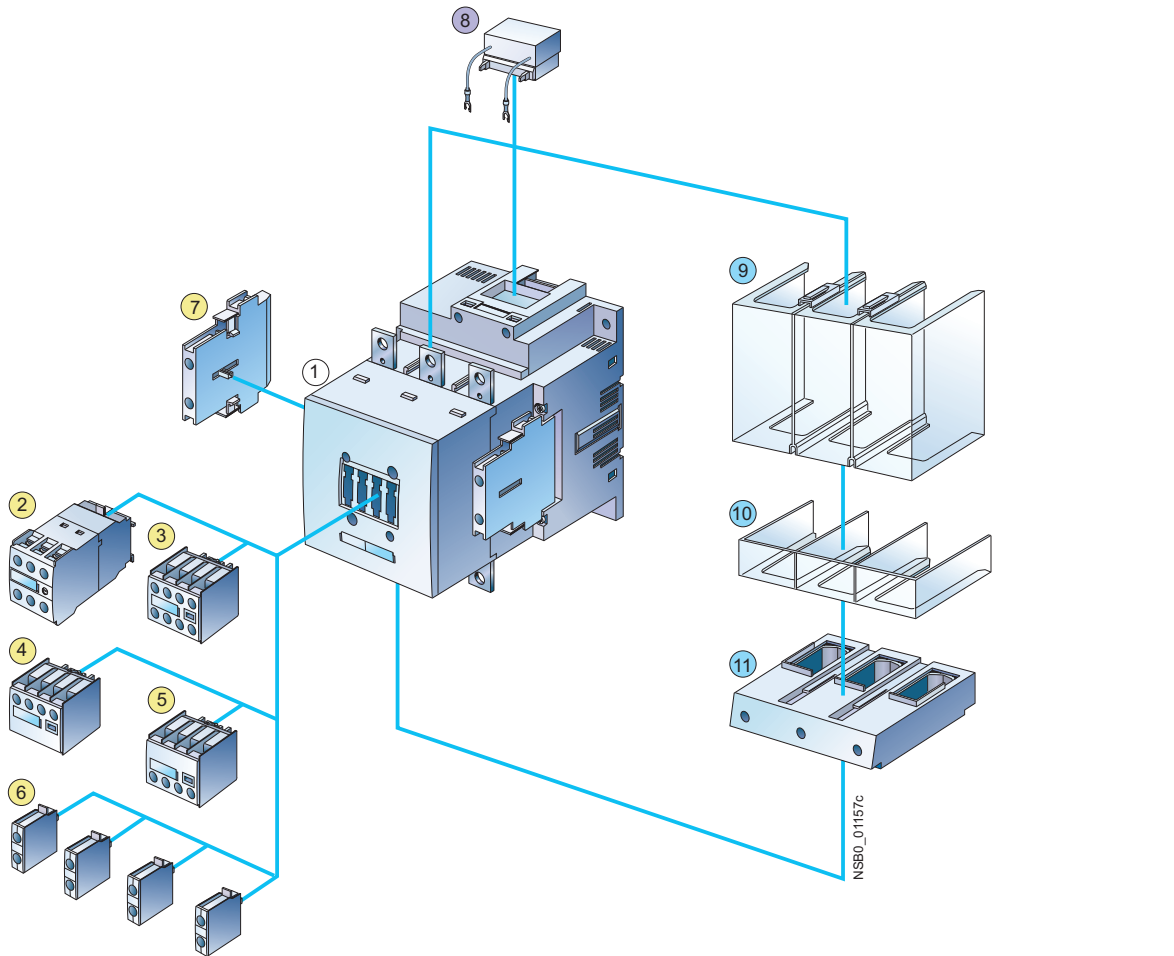

- ① 3RT10 and 3RT14 air-break contactor, sizes S6, S10 and S12
- ② Auxiliary switch block with solid-state time delay (ON or OFF-delay or wye-delta function)
- ③ 4-pole auxiliary switch block (terminal designations according to EN 50012 or EN 50005)
- ④ 2-pole auxiliary switch block, cable entry from above
- ⑤ 2-pole auxiliary switch block, cable entry from below
- ⑥ Single-pole auxiliary switch block (up to 4 can be snapped on)
- ⑦ 2-pole auxiliary switch block, laterally mountable left or right (terminal designations according to EN 50012 or EN 50005) (identical for S0 to S12)
- ⑧ Surge suppressor (RC element), for plugging into top of withdrawable coil

- ⑨ Terminal cover for cable lug and busbar connection, different for sizes S6 and S10/S12
- ⑩ Terminal cover for box terminal, different for sizes S6 and S10/S12
- ⑪ Box terminal block, different for sizes S6 and S10/S12

- Accessories identical for sizes S0 to S12
- Accessories identical for sizes S6 to S12
- Accessories differ according to size

For mountable overload relays see "Protection Equipment --> Overload Relays".

3RT, 3TB, 3TF Contactors for Switching Motors

General data

3RA1 contactor assemblies, 3RT1 contactors
Size S6 with accessories

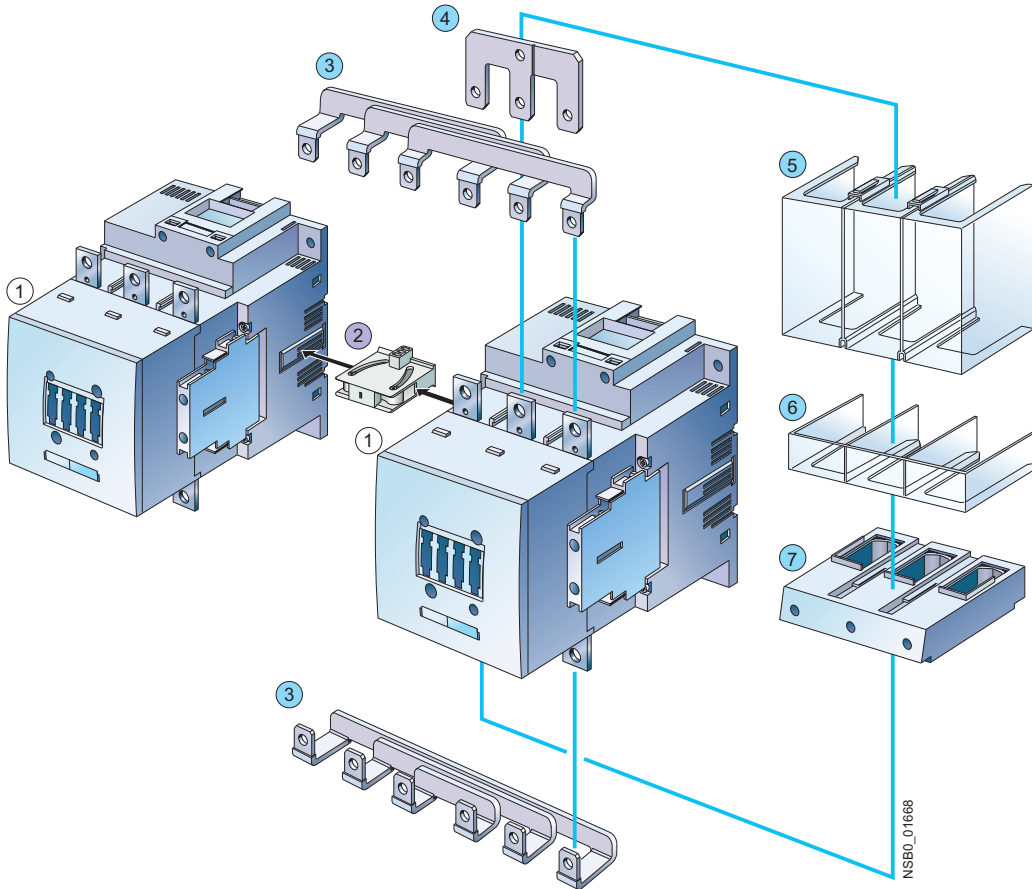

- ① 3RT10 and 3RT14 air-break contactor, size S6
- ② 3RA19 54-2A mechanical interlock, laterally mountable
- ③ 3RA19 53-2A wiring modules on the top and bottom
- ④ 3RT19 56-4BA31 link for paralleling (star jumper), 3-pole, with through hole
- ⑤ Terminal cover for cable lug and busbar connection, different for sizes S6 and S10/S12
- ⑥ Terminal cover for box terminal, different for sizes S6 and S10/S12
- ⑦ Box terminal block, different for sizes S6 and S10/S12

- Accessories identical for sizes S6 to S12
- Accessories differ according to size

For mountable overload relays see "Protection Equipment --> Overload Relays".

3RT, 3TB, 3TF Contactors for Switching Motors

General data

3RA1 contactor assemblies, 3RT1 contactors
 Sizes S10 and S12 with accessories

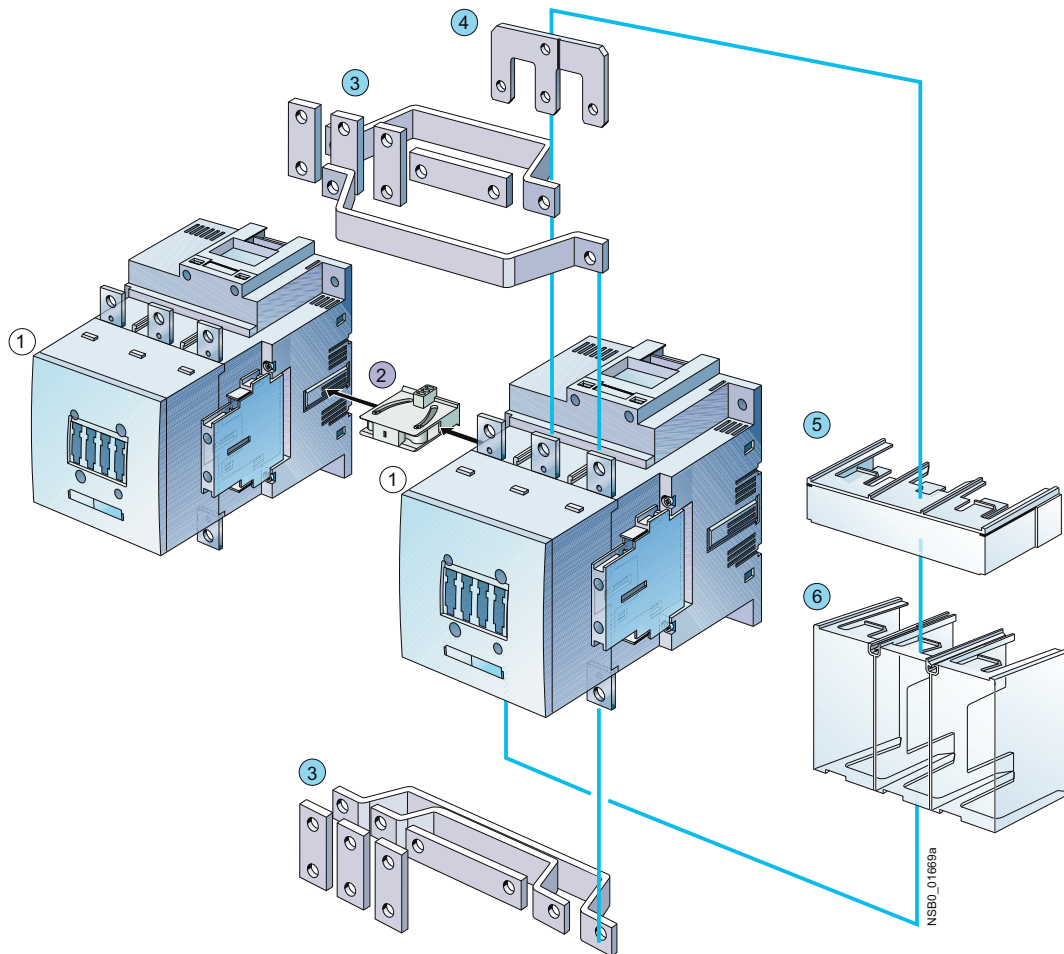

① 3RT10 and 3RT14 air-break contactor, sizes S6, S10 and S12 or
 3RT12 vacuum contactor, sizes S10 and S12

② Mechanical interlock, laterally mountable

③ 3RA19 wiring modules on the top and bottom

④ 3RT19 56-4BA31 link for paralleling (star jumper), 3-pole,
 with through hole

⑤ Terminal cover for box terminal,
 different for sizes S6 and S10/S12

⑥ Terminal cover for cable lug and busbar connection,
 different for sizes S6 and S10/S12

● Accessories identical for sizes S6 to S12

● Accessories differ according to size

For mountable overload relays see "Protection Equipment -->
 Overload Relays".

3RT, 3TB, 3TF Contactors for Switching Motors

General data

3RT1 contactors Sizes S6 to S12 with accessories

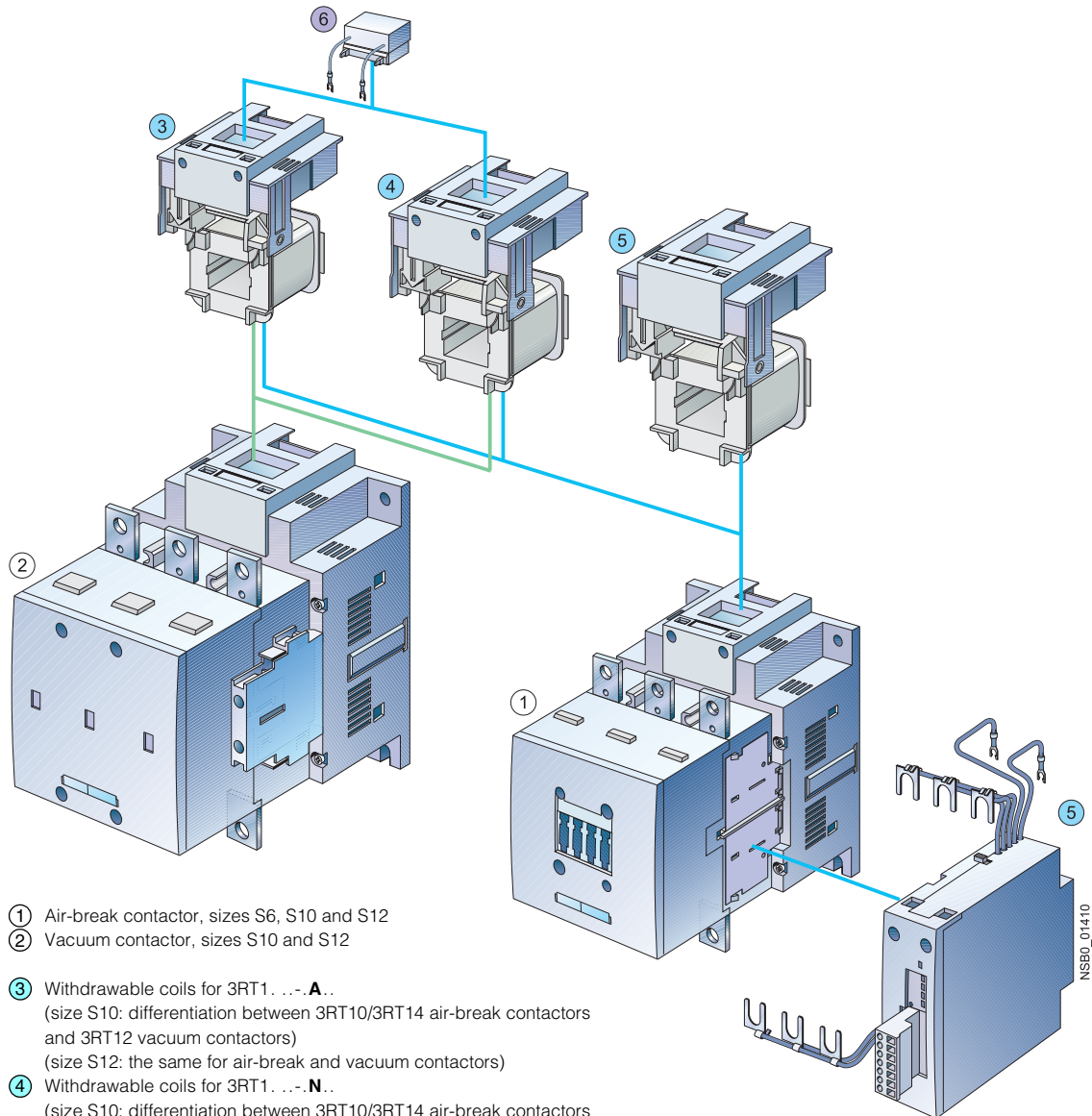

- ① Air-break contactor, sizes S6, S10 and S12
 ② Vacuum contactor, sizes S10 and S12
- ③ Withdrawable coils for 3RT1...-A...
 (size S10: differentiation between 3RT10/3RT14 air-break contactors and 3RT12 vacuum contactors)
 (size S12: the same for air-break and vacuum contactors)
- ④ Withdrawable coils for 3RT1...-N...
 (size S10: differentiation between 3RT10/3RT14 air-break contactors and 3RT12 vacuum contactors)
 (size S12: the same for air-break and vacuum contactors)
- ⑤ Withdrawable coils and laterally mountable module (plug-on) for air-break contactors with solid-state operating mechanism and remaining lifetime indicator 3RT1...-P... and 3RT1...-Q...
- ⑥ Surge suppressor (RC element), plug-mountable on withdrawable coils
- With conventional operating mechanism 3RT1...-A...
 - With solid-state operating mechanism 3RT1...-N...

- ① Identical for sizes S6 to S12
 ② Different according to size

For mountable overload relays see "Protection Equipment --> Overload Relays".

Overview

3RT10 contactors, 3-pole, sizes S00 to S3, up to 45 kW

AC and DC operation

IEC 60947, EN 60947 (VDE 0660)

The 3RT1 contactors are climate-proof. They are finger-safe according to EN 50274.

Size S00 contactors have an auxiliary contact integrated in the basic unit. The basic units of sizes S0 to S3 contain only the main current paths.

All basic units can be extended with auxiliary switch blocks. For size S0 and higher, complete units with 2 NO + 2 NC are available (connection designation according to EN 50012). The auxiliary switch block can be removed ([for more information see Integration](#)).

In addition, complete units with permanently mounted auxiliary switch block (2 NO + 2 NC according to EN 50012) are offered for sizes S00 and S0. These versions are built according to special Swiss regulations "SUVA" and are distinguished externally by a red labeling plate.

Connection method

The 3RT1 contactors are available with screw terminals (box terminals and connecting bars) or with Cage Clamp terminals.

The size S3 contactors have removable box terminals for the main conductor connections. This permits connection of ring terminal lugs or busbars.

Contact reliability

If voltages ≤ 110 V and current ≤ 100 mA are to be switched, the auxiliary contacts of the 3RT1 contactor or 3RH11 contactor relay should be used as they guarantee a high level of contact reliability.

These auxiliary contacts are suitable for solid-state circuits with currents ≥ 1 mA at a voltage of 17 V.

Short-circuit protection of the contactors

[Short-circuit protection of the contactors without overload relay, see "Technical specifications". For short-circuit protection of the contactors with overload relay, see "Overload Relays".](#) To assemble fuseless motor feeders you must select combinations of motor starter protector and contactor as explained in "Fuseless Load Feeders".

Motor protection

3RU11 thermal overload relays or 3RB20 solid-state overload relays can be fitted to the 3RT1 contactors for protection against overload. The overload relays must be ordered separately.

Ratings of induction motors

The quoted rating (in kW) refers to the output power on the motor shaft (according to the nameplate).

Surge suppression

3RT1 contactors can be retrofitted with RC elements, varistors, diodes or diode assemblies (assembly of diode and Zener diode for short break times) for damping opening surges in the coil.

The surge suppressors are plugged onto the front of size S00 contactors. Space is provided for them next to a snap-on auxiliary switch block.

For size S0 to S3 contactors, varistors and RC elements can be snapped on either on the top or directly below the coil terminals. Diode assemblies are available in 2 different versions on account of their polarity. Depending on the application they can be connected either only at the bottom (assembly with motor starter protector) or only at the top (assembly with overload relay).

The plug-in direction of the diodes and diode assemblies is specified by coding.

Exceptions:

3RT19 26-1T.00 and

3RT19 36-1T.00, in this case the plug-in direction is marked with "+" and "-".

Coupling relays are supplied either without overvoltage damping or with a varistor or diode connected as standard, according to the version.

Note:

The OFF-delay times of the NO contacts and the ON-delay times of the NC contacts increase if the contactor coils are damped against voltage peaks (noise suppression diode 6 to 10 times; diode assemblies 2 to 6 times, varistor +2 to 5 ms).

3RT10 contactors, 3-pole, sizes S6 to S12, > 45 to 250 kW

- 3RT10, contactors for switching motors,
- 3RT12, vacuum contactors for switching motors,
- 3RT14, contactors for AC-1 applications.

Operating mechanism types

Two types of solenoid operation are available:

- Conventional operating mechanism
- Solid-state operating mechanism (with 3 performance levels)

UC operation

The contactors can be operated with AC (40 to 60 Hz) as well as with DC.

Withdrawable coils

For simple coil replacement, e. g., if the application is replaced, the magnetic coil can be pulled out upwards after the release mechanism has been actuated and can be replaced by any other coil of the same size.

Auxiliary contact complement

[For details of the auxiliary switch fittings per S0-S12 contactor see page 3/16.](#)

- 3RT10 and 3RT14 contactors:
Auxiliary contacts mounted laterally and on front
- 3RT12 vacuum contactors:
Auxiliary contacts mounted laterally

Note:

[Auxiliary contact complement according to SUVA.](#)

Contactors with permanently mounted auxiliary switch block for safety applications according to SUVA.

Contactors with conventional operating mechanism

Version 3RT1. ...A:

The magnetic coil is switched directly on and off with the control supply voltage U_s by way of terminals A1/A2.

Multi-voltage range for the control supply voltage U_s :
Several closely adjacent control supply voltages, available around the world, are covered by just one coil, for example 110-115-120-127 V UC or 220-230-240 V UC.

In addition, allowance is also made for a coil operating range of 0.8 times the lower ($U_{s \min}$) and 1.1 times the upper ($U_{s \max}$) rated control supply voltage within which the contactor switches reliably and no thermal overloading occurs.

3RT, 3TB, 3TF Contactors for Switching Motors

3RT10 contactors, 3-pole, 3 ... 250 kW

Contactors with solid-state operating mechanism

The magnetic coil is supplied selectively with the power required for reliable switching and holding by upstream control electronics.

- Wide voltage range for the control supply voltage U_s :
Compared with the conventional operating mechanism, the solid-state operating mechanism covers an even broader range of control supply voltages used worldwide within one coil variant. For example, the coil for 200 to 277 V UC ($U_{s \min}$ to $U_{s \max}$) covers the voltages 200-208-220-230-240-254-277 V used worldwide.
- Extended operating range 0.7 to $1.25 \times U_s$:
The wide range for the rated control supply voltage and the additionally allowed coil operating range of $0.8 \times U_{s \min}$ to $1.1 \times U_{s \max}$ results in an extended coil operating range of at least 0.7 to $1.25 \times U_s$, within which the contactors will operate reliably, for the most common control supply voltages of 24, 110 and 230 V.
- Bridging temporary voltage dips:
Control voltage failures dipping to 0 V (at A1/A2) are bridged for up to approx. 25 ms to avoid unintentional tripping.
- Defined ON and OFF thresholds:
For voltages of $\geq 0.8 \times U_{s \min}$ and higher the electronics will reliably switch the contactor ON, and as of $\leq 0.5 \times U_{s \min}$ it is reliably switched off. The hysteresis in the switching thresholds prevents the main contacts from chattering as well as increased wear or welding when operated in weak, unstable networks. This also prevents thermal overloading of the contactor coil if the voltage applied is too low (contactor does not close properly and is continuously operated with overexcitation).
- Low control power consumption when closing and in the closed state.

Electromagnetic compatibility (EMC)

The contactors with solid-state operating mechanism comply with the requirements for operation in industrial plants.

- Interference immunity
 - Burst (IEC 61000-4-4): 4 kV
 - Surge (IEC 61000-4-5): 4 kV
 - Electrostatic discharge, ESD (IEC 61000-4-2): 8/15 kV
 - Electromagnetic field (IEC 61000-4-3): 10 V/m
- Emitted interference
 - Limit value class A according to EN 55011

Note:

In connection with converters, the control cables should be installed separately from the load cables of the converter.

Indication of remaining lifetime (RLT)

Main contactor contacts are working parts which must be replaced in good time when the end of their service life has been reached. The degree of contact erosion and thus the electrical endurance (= number of operating cycles) depends on the loading, utilization category, operating mode, etc. Up to now, routine checks/visual inspections by the maintenance personnel were needed in order to gain an insight into the state of the main contacts. The remaining lifetime indication function now takes over this task. It does not count the number of operating cycles – which does not provide information about contact erosion – but instead electronically identifies, evaluates and stores the actual progress of erosion of each one of the three main contacts, and outputs a warning when specified limits are reached. The stored data are not lost even if the control supply voltage for A1/A2 fails. After replacement of the main contacts, measurement the remaining lifetime must be reset using the "RESET" button (hold down RESET button for about 2 seconds using a pen or similar tool).

Advantages:

- Signaling through relay contact or AS-i when remaining life-time is 20 %, i. e. contact material wear is 80 %
- Additional visual indication of various levels of erosion by means of LEDs on the laterally mounted solid-state module when remaining lifetime is 60 % (green), 40 % (orange) and 20 % (red)

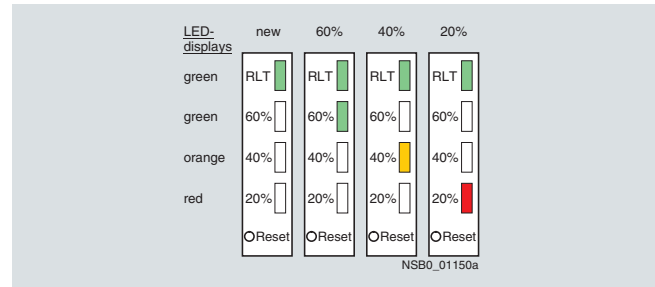

- Early warning to replace contacts
- Optimum utilization of contact material
- Visual inspection of the condition of contacts no longer necessary
- Reduction of ongoing operating costs
- Optimum planning of maintenance measures
- Avoidance of unforeseen plant downtimes

3RT1. ...-N version: for 24 V DC PLC output

2 control options:

- Control without a coupling link directly through a 24 V DC ≥ 30 mA PLC output (EN 61131-2). Connection by means of 2-pole plug-in connection. The screwless spring-type connection is part of the scope of supply. The control supply voltage which supplies the solenoid operating mechanism must be connected to A1/A2.

Note:

Before start-up, the slide switch for PLC operation must be moved to the "PLC ON" position (setting ex works: "PLC OFF").

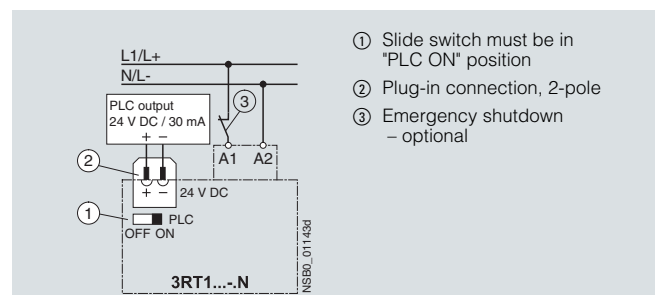

- Conventional control by applying the control supply voltage at A1/A2 through a switching contact.

Note:

The slide switch must be in the "PLC OFF" position (= setting ex works).

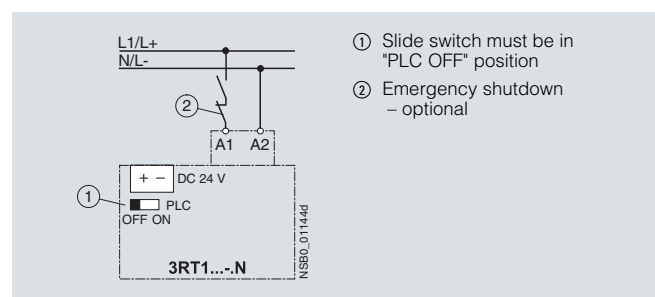

3RT, 3TB, 3TF Contactors for Switching Motors

3RT10 contactors, 3-pole, 3 ... 250 kW

3RT1...-P version: For 24 V DC PLC output or PLC relay output, with remaining lifetime indicator (RLT).

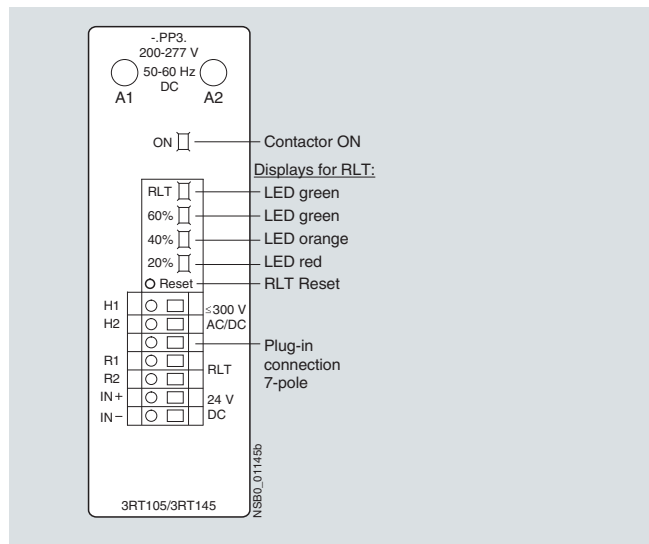

To supply the solenoid and the remaining lifetime indicator with power, the control supply voltage U_s must be connected to terminals A1/A2 of the laterally mounted solid-state module. The control inputs of the contactor are connected to a 7-pole plug-in connection; the screwless spring-type connection is part of the scope of supply.

- The "Remaining Lifetime RLT" status signal is available at terminals R1/R2 through a floating relay contact (hard gold-plated, enclosed) and can be input to SIMOCODE, PLC or other devices for processing, for example. Permissible current-carrying capacity of the R1/R2 relay output:
 - I_{th}/AC -15/24 to 230 V: 3 A
 - I_{th}/DC -13/24 V: 1 A
- LED indications
The following states are indicated by means of LEDs on the laterally mounted solid-state module:
 - Contactor ON (energized state): green LED ("ON")
 - Indication of remaining lifetime

2 control options:

- Contactor control without a coupling link directly through a 24 V DC/ ≥ 30 mA PLC output (EN 61131-2) by way of terminals IN+/IN-.

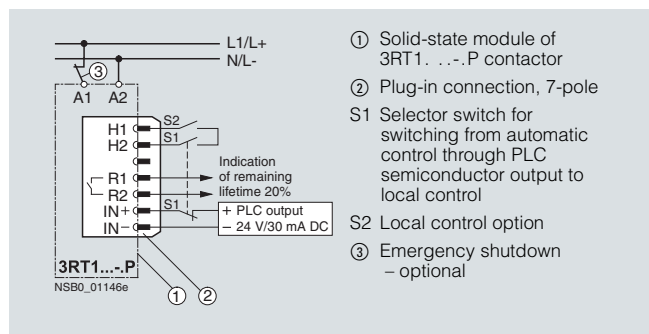

Possibility of switching from automatic control to local control by way of terminals H1/H2, i. e. automatic control through PLC or SIMOCODE/PROFIBUS DP can be deactivated e. g. at start-up or in the event of a fault and the contactor can be controlled manually.

- Contactor control through relay outputs, e. g. by
 - PLC
 - SIMOCODE
 by way of terminals H1/H2. Contact loading: U_s /approx. 5 mA. When operated through SIMOCODE, a communication link to PROFIBUS DP is also provided.

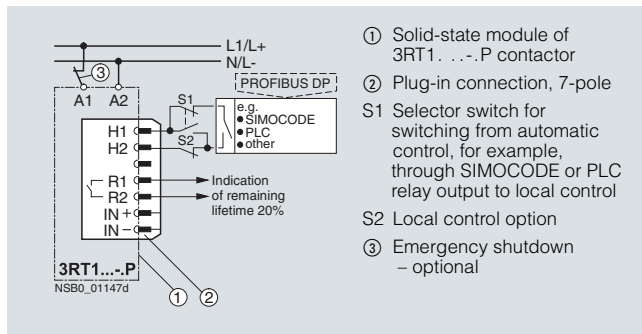

3RT1...-Q version: Communication-capable with integrated AS-Interface and remaining lifetime indicator (RLT)

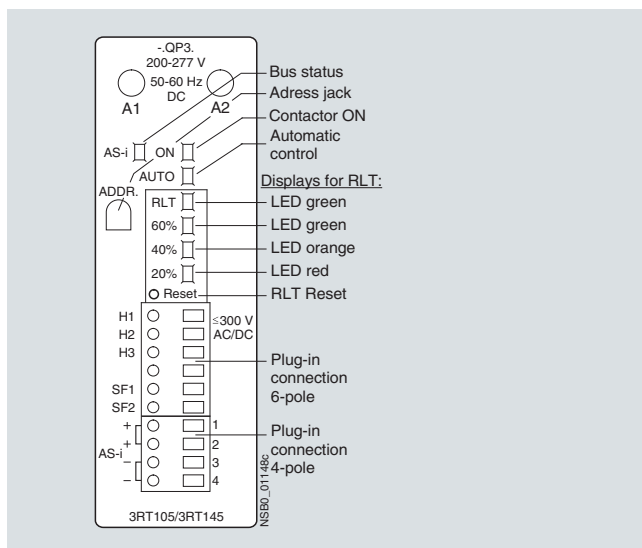

To supply the solenoid and the remaining lifetime indicator with power, the control supply voltage U_s must be connected to terminals A1/A2 of the laterally mounted solid-state module. The contactor itself is controlled by way of the integrated AS-Interface interface. The inputs and outputs are connected to a 10-pole plug-in connection; the screwless spring-type connections (6-pole for external connection and 4-pole for AS-Interface connection) are part of the scope of supply.

- LED indications
The following states are indicated by means of LEDs on the laterally mounted solid-state module:
 - Contactor ON (energized state): green LED ("ON")
 - Automatic/Local control: green LED ("AUTO")
 - Bus status: green/red dual LED ("AS-i")
 - Remaining lifetime indicator (RLT)
- AS-Interface addressing socket "ADDR":
The contactor address can be assigned after installation.

3RT, 3TB, 3TF Contactors for Switching Motors

3RT10 contactors, 3-pole, 3 ... 250 kW

Control circuit:

- Contactor control through AS-Interface by way of terminals AS-i +/AS-i -. Each of these terminals is jumpered and connected twice to a 4-pole connector which is separate from the other control inputs.

Advantages:

- The AS-Interface cable is not interrupted if the connector is pulled out
- The contactor remains functional through the local control inputs and its own 6-pole connector
- Control signals through AS-i:
 - Contactor ON/OFF
- Status signals through AS-i:
 - Contactor ON/OFF
 - Automatic/local control
 - Remaining lifetime indicator (RLT)
 - Signal through free input, e. g. overload relay tripped.

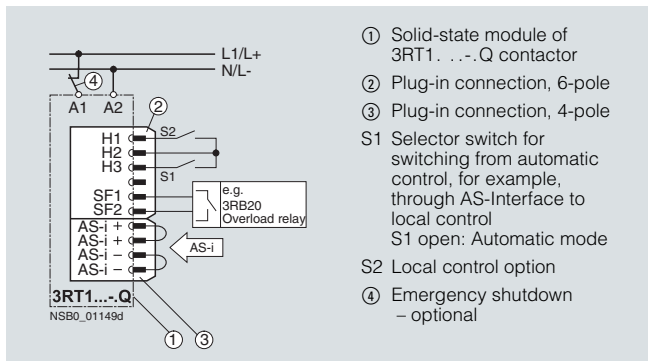

- ① Solid-state module of 3RT1...-Q contactor
- ② Plug-in connection, 6-pole
- ③ Plug-in connection, 4-pole
- S1 Selector switch for switching from automatic control, for example, through AS-Interface to local control
S1 open: Automatic mode
- S2 Local control option
- ④ Emergency shutdown - optional

Possibility of switching from automatic control to local control by means of terminals H1/H2/H3, i. e. automatic control through AS-Interface can be deactivated e. g. during startup or in the event of a fault and the contactor can be controlled manually.

I/O configuration (hex)	7
ID code (hex)	F
Power supply	V 26.5 ... 31.6 (acc. to AS-Interface specification)
AS-Interface power consumption	mA Max. 20
Contact loading at SF1/2	mA 3 ... 6
Watchdog function (disconnects outputs in the event of AS-Interface fault)	Built-in

Indication behavior

During operation, the LEDs on the contactor indicate the states shown on the right.

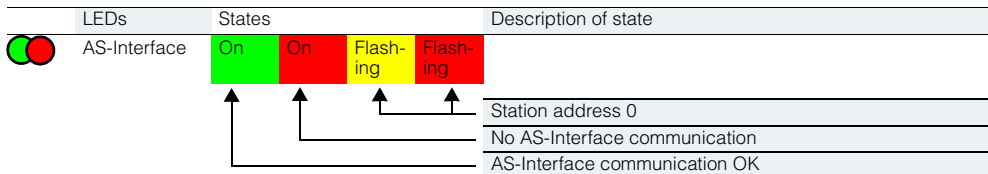

Contactor diagnostics using the user program

• Inputs

Input signals	Device status
D10 "Ready"	0 Device not ready/manual operation 1 Device ready/automatic mode
D11 "Running"	0 Contactor off 1 Contactor on
D12 "Remaining lifetime"	0 Remaining lifetime RLT > 20 % 1 Remaining lifetime RLT ≤ 20 %
D13 "Free input"	0 No input signal at SF1/2 1 Input signal at SF1/2

• Outputs

Output signals	Device status
DO0 "Running"	0 Contactor off 1 Contactor on
DO1	0 -- 1 --
DO2	0 -- 1 --
DO3	0 -- 1 --

Integration

Auxiliary switch blocks

Various auxiliary switch blocks can be added to the 3RT1 basic units depending on the application:

Size S00

3RT10 1. contactors

Terminal designations according to EN 50012 or EN 50005.

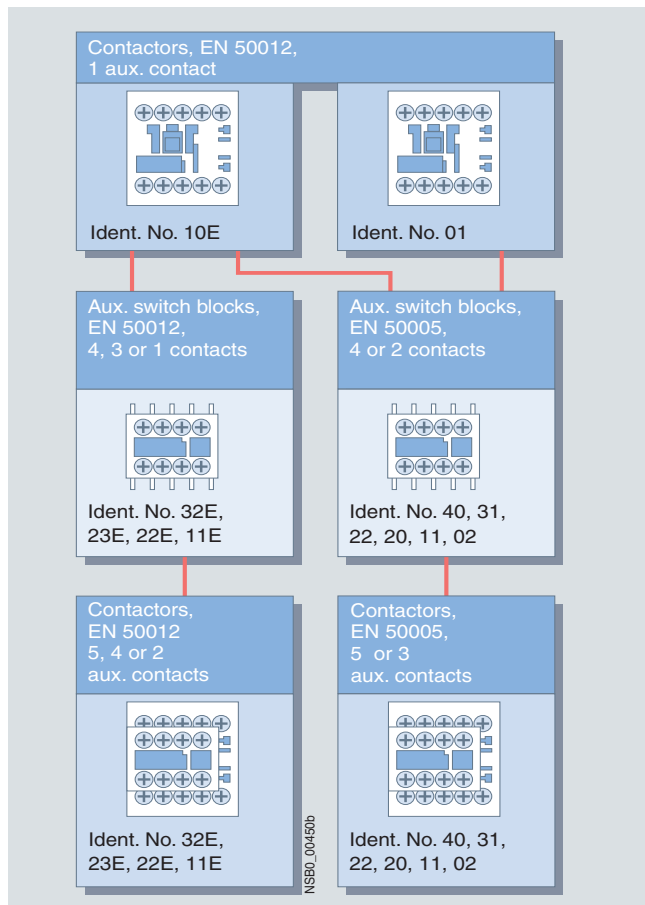

Size S00 contactors have an auxiliary contact integrated in the basic unit.

Contactors with a NO contact as auxiliary contact with screw or Cage Clamp terminals, identification number 10E, can be expanded into contactors with 2, 4 and 5 auxiliary contacts according to EN 50012 using auxiliary switch blocks. The identification numbers 11E, 22E, 23E and 32E on the auxiliary switch blocks apply to the complete contactors. These auxiliary switch blocks cannot be combined with contactors which have a NC contact in the basic unit (identification number 01) as they are coded.

All contactors of size S00 with one auxiliary contact (identification numbers 10E or 01) and the contactors with 4 main contacts can be expanded into contactors with 3 or 5 auxiliary contacts using auxiliary switch blocks with the identification numbers 40 to 02 (in the case of contactors with 4 main contacts: 2 or 4 auxiliary contacts) according to EN 50005.

The identification numbers on the auxiliary switch blocks apply only to the attached auxiliary switches. Single- or two-pole auxiliary switch blocks with connection options from above or below enable easy and clearly arranged wiring especially for the installation of network access junctions. These auxiliary switch blocks are offered only with screw terminals.

The solid-state compatible 3RH19 11-1NF.. auxiliary switch blocks for contactors of size S00 include 2 enclosed contacts. They are suitable in particular for switching small voltages and currents (hard gold-plated contacts) and for operation in dusty atmospheres. The NC auxiliary contacts are not mirror contacts.

All the previously mentioned auxiliary switch variants can be snap-fitted onto the front of the contactor. The auxiliary switch block has a centrally positioned release lever for disassembly.

Sizes S0 to S3

3RT10 2. to 3RT10 4. contactors,

1-pole auxiliary switch blocks,

terminal designations according to EN 50005 or EN 50012.

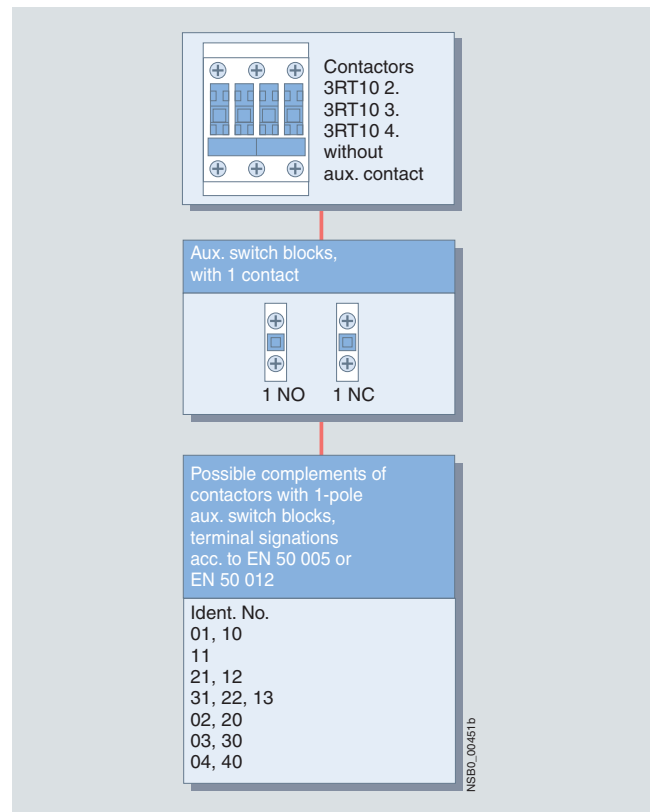

3RT, 3TB, 3TF Contactors for Switching Motors

3RT10 contactors, 3-pole, 3 ... 250 kW

3RT10 2. to 3RT10 4. contactors, 4-pole auxiliary switch blocks,
terminal designations according to EN 50005 or EN 50012

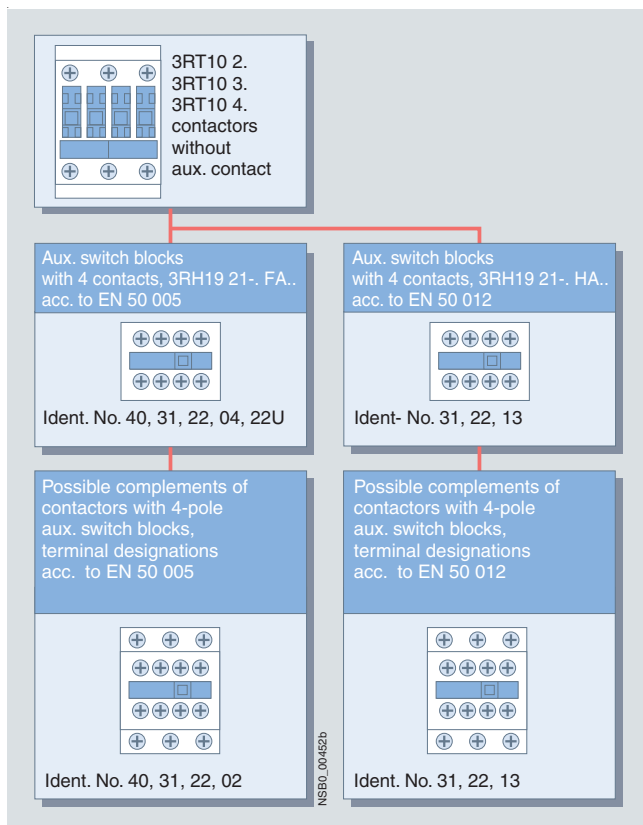

A diverse range of auxiliary switch blocks is available for various applications. The contactors themselves have no integrated conducting path.

The auxiliary switch variants are uniform for the contactors of size S0 to S12.

One 4-pole or up to four single-pole auxiliary switch blocks (screw or Cage Clamp terminals) can be snapped on. When the contactors are switched on, the NC contacts are opened first and then the NO contacts are closed.

The terminal designations of the single-pole auxiliary switch locks are comprised of identification numbers (location identifiers) on the basic unit and of function numbers on the auxiliary switch blocks.

Also available are 2-pole auxiliary switch blocks (screw terminals) for cable entry from above or below in the design of a quad block (feeder auxiliary switch).

If the installation space is limited in depth, 2-pole auxiliary switch blocks (screw or Cage Clamp terminals) can be attached laterally for use on the left or on the right.

The auxiliary switch blocks attached to the front can be disassembled with the help of a centrally arranged release lever; the laterally attached auxiliary switch blocks are easy to remove by pressing on the checkered surfaces.

The terminal designation of the individual auxiliary switch blocks corresponds to EN 50005 or EN 50012, that of the complete contactor with auxiliary switch block 2 NO + 2 NC corresponds to EN 50012.

The laterally attachable auxiliary switch blocks according to EN 50012 can be used only when no 4-pole auxiliary switch blocks are snapped onto the front. If single-pole auxiliary switch blocks are used in addition, the location identifiers on the contactor must be noted.

Two enclosed and 2 standard contacts are available with the 3RH19 21-.FE22 solid-state compatible auxiliary switch block, which can be attached to the front. The 3RH19 21-2DE11 laterally mountable auxiliary switch block contains 2 enclosed contacts (1 NO + 1 NC). The enclosed contacts are suitable in particular for switching small voltages and currents (hard gold-plated contacts) and for operation in dusty atmospheres. The NC auxiliary contacts are mirror contacts.

Sizes S0 and S2

A maximum of 4 auxiliary contacts can be attached; the auxiliary switch blocks used can be of any version. For reasons of symmetry, when two 2-pole laterally mountable auxiliary switch blocks are used, one block must be attached on the right and one on the left.

More auxiliary contacts are permissible with size S2 under certain conditions (please ask).

For 4-pole contactors see 3RT13 and 3RT15.

Size S3 to S12

A maximum of 8 auxiliary contacts can be attached; please note the following:

- Of these 8 auxiliary contacts, there must be no more than 4 NC contacts
- Ensure the symmetry of laterally mounted auxiliary switch blocks

For 4-pole contactors see 3RT13 and 3RT15.

3RT, 3TB, 3TF Contactors for Switching Motors

3RT10 contactors, 3-pole, 3 ... 250 kW

Technical specifications

SIRIUS controls are climate-proof and are suitable and tested for use worldwide.

If the devices are used in ambient conditions which deviate from common industrial conditions (EN 60721-3-3 "Stationary Use,

Weather-Protected"), the manufacturer must be consulted about possible restrictions with regard to the reliability and endurance of the device and possible protective measures.

Contactors	Type Size	3RT1 S00 ... S12	
Rated data of the auxiliary contacts			
Acc. to IEC 60947-5-1/EN 60947-5-1 (VDE 0660 Part 200) The data apply to integrated auxiliary contacts and contacts in the auxiliary switch blocks for contactor sizes S00 to S12 ¹⁾			
Rated insulation voltage U_i (degree of pollution 3)	V	690	
For 3RH19 21-. laterally mountable auxiliary switch blocks	V	Max. 500	
Continuous thermal current I_{th} = Rated operational current $I_e/AC-12$	A	10	
AC load			
Rated operational current $I_e/AC-15/AC-14$			
• For rated operational voltage U_e			
	24 V	A	6
	110 V	A	6
	125 V	A	6
	220 V	A	6
	230 V	A	6
	380 V	A	3
	400 V	A	3
	500 V	A	2
	660 V ²⁾	A	1
	690 V ²⁾	A	1
DC load			
Rated operational current $I_e/DC-12$			
• For rated operational voltage U_e			
	24 V	A	10
	60 V	A	6
	110 V	A	3
	125 V	A	2
	220 V	A	1
	440 V	A	0.3
	600 V ²⁾	A	0.15
Rated operational current $I_e/DC-13$			
• For rated operational voltage U_e			
	24 V	A	10 ¹⁾
	60 V	A	2
	110 V	A	1
	125 V	A	0.9
	220 V	A	0.3
	440 V	A	0.14
	600 V ²⁾	A	0.1
Contact reliability at 17 V, 1 mA acc. to EN 60947-5-4		Frequency of contact faults < 10^{-8} i. e. < 1 fault per 100 million operating cycles	

Endurance of the auxiliary contacts

It is assumed that the operating mechanisms are switched randomly, i. e. not synchronized with the phase angle of the supply system. The contact endurance is mainly dependent on the breaking current.

The characteristic curves apply to:

- Integrated auxiliary contacts on 3RT10
- Auxiliary switch blocks 3RH19 11, 3RH19 21 for contactors of size S00 to S12

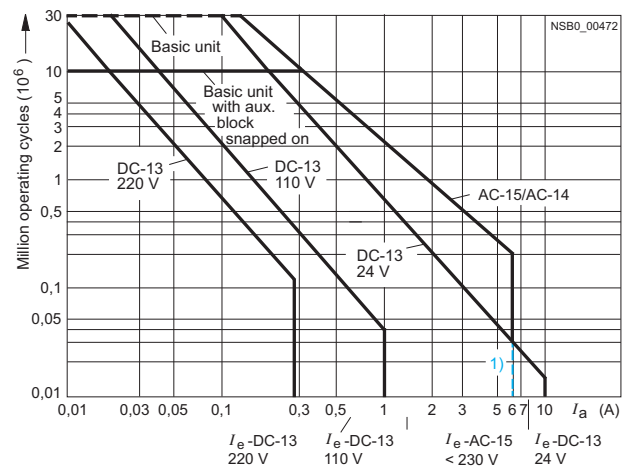

¹⁾ Snap-on auxiliary switch blocks for size S00 and laterally mountable auxiliary switch blocks for S0 to S12: 6 A.

²⁾ Up to 500 V switching capacity for laterally mountable auxiliary switch blocks.

3RT, 3TB, 3TF Contactors for Switching Motors

3RT10 contactors, 3-pole, 3 ... 250 kW

Endurance of the main contacts

The characteristic curves show the contact endurance of the contactors when switching resistive and inductive AC loads (AC-1/AC-3) depending on the breaking current and rated operational voltage. It is assumed that the operating mechanisms are switched randomly, i. e. not synchronized with the phase angle of the supply system.

The rated operational current I_e complies with utilization category AC-4 (breaking six times the rated operational current) and is intended for a contact endurance of at least 200 000 operating cycles.

If a shorter endurance is sufficient, the rated operational current I_e /AC-4 can be increased.

If the contacts are used for **mixed operation**, i. e. normal switching (breaking the rated operational current according to utilization category AC-3) in combination with intermittent inching (breaking several times the rated operational current according to utilization category AC-4), the contact endurance can be calculated approximately from the following equation:

$$X = \frac{A}{1 + \frac{C}{100} \left(\frac{A}{B} - 1 \right)}$$

Characters in the equation:

- X Contact endurance for mixed operation in operating cycles
- A Contact endurance for normal operation ($I_a = I_e$) in operating cycles
- B Contact endurance for inching ($I_a = \text{multiple of } I_e$) in operating cycles
- C Inching operations as a percentage of total switching operations

Diagram legend:

P_N = Rated power for squirrel-cage motors at 400 V

I_a = Breaking current

I_e = Rated operational current

Size S00

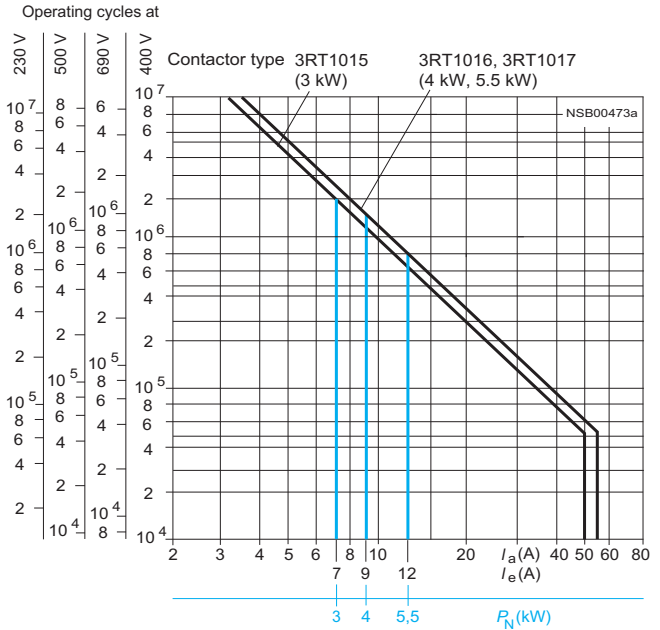

Size S0

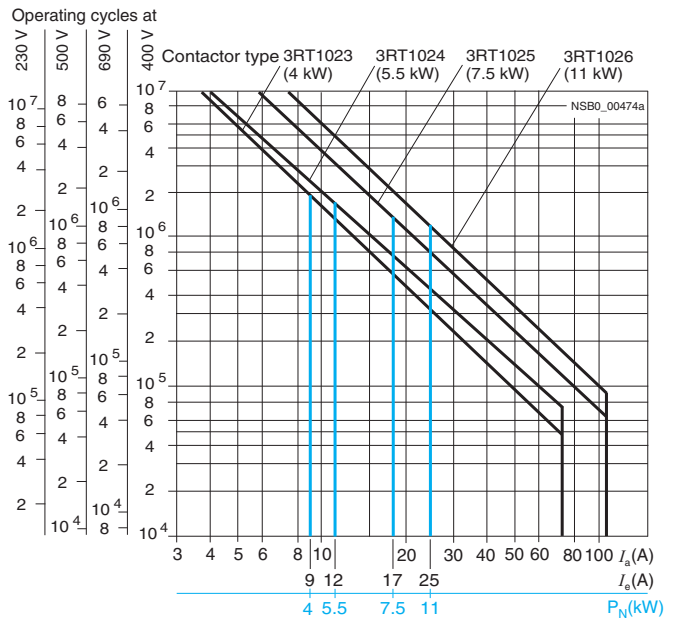

3RT, 3TB, 3TF Contactors for Switching Motors

3RT10 contactors, 3-pole, 3 ... 250 kW

Endurance of the main contacts

Size S2

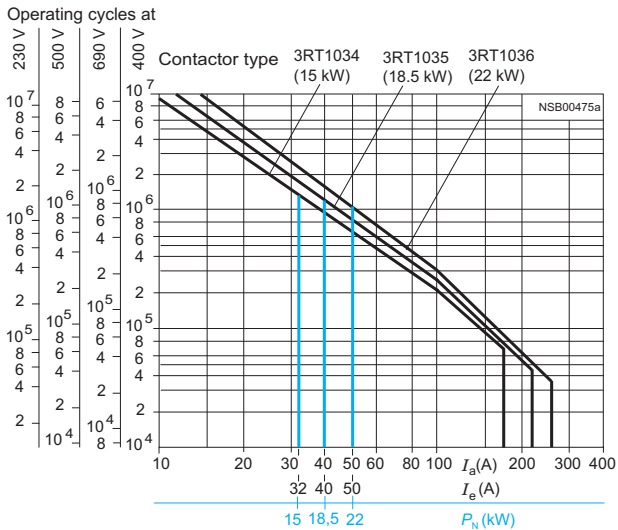

Size S3

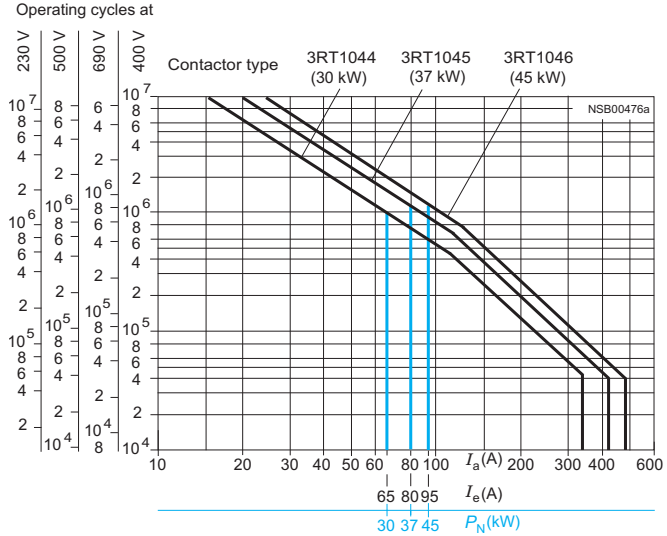

Sizes S6 to S12

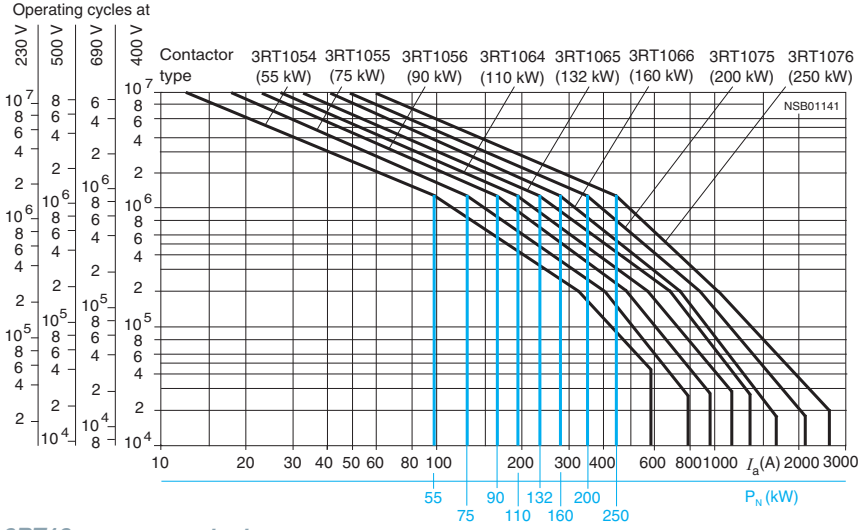

3RT12 vacuum contactors

Sizes S10 and S12

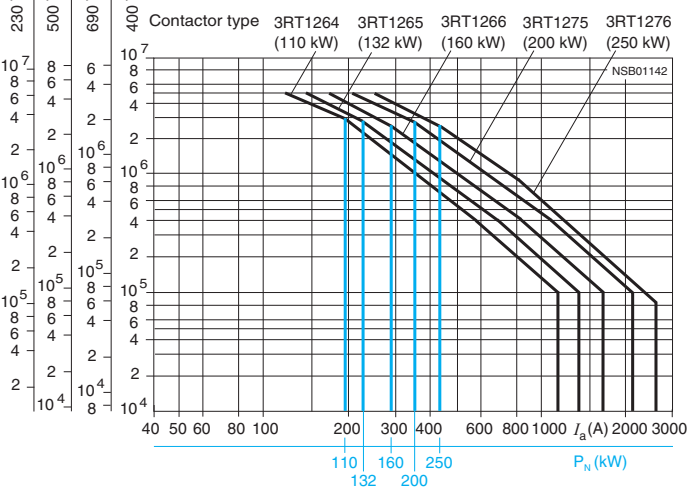
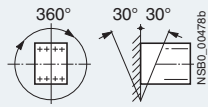



Diagram legend:
 P_N = Rated power for squirrel-cage motors at 400 V
 I_a = Breaking current
 I_e = Rated operational current



3RT, 3TB, 3TF Contactors for Switching Motors

3RT10 contactors, 3-pole, 3 ... 250 kW

Contactor	Type Size	3RT10 1. S00	
General data			
Permissible mounting position The contactors are designed for operation on a vertical mounting surface.	<ul style="list-style-type: none"> AC and DC operation 		
Upright mounting position:	<ul style="list-style-type: none"> AC operation DC operation 	 Special version required. Standard version	
Mechanical endurance	<ul style="list-style-type: none"> Basic units Basic unit with snap-on auxiliary switch block Solid-state compatible auxiliary switch block 	Operating cycles	30 million 10 million 5 million
Electrical endurance			
Rated insulation voltage U_i (degree of pollution 3)	V		690
Rated impulse withstand voltage U_{imp}	kV		6
Protective separation between the coil and the main contacts acc. to EN 60947-1, Appendix N	V		400
Mirror contacts	<ul style="list-style-type: none"> A mirror contact is an auxiliary NC contact that cannot be closed simultaneously with a NO main contact. No mirror contacts for the solid-state compatible auxiliary switch blocks 	<ul style="list-style-type: none"> 3RT10 1., 3RT13 1. (removable auxiliary switch block) 3RT10 1., 3RT13 1. (non-removable auxiliary switch block) 3RH19 11-.NF.. 	Yes, this applies to both the basic unit as well as to between the basic unit and the mounted auxiliary switch block acc. to EN 60947-4-1, Appendix F. Yes, acc. to EN 60947-4-1, Appendix F, SUVA
Ambient temperature	<ul style="list-style-type: none"> During operation During storage 	°C	-25 ... +60 -55 ... +80
Degree of protection acc. to EN 60947-1, Appendix C			IP20, coil assembly IP40
Touch protection acc. to EN 50274			Finger-safe
Shock resistance rectangular pulse	<ul style="list-style-type: none"> AC operation DC operation 	g/ms g/ms	7/5 and 4.2/10 7/5 and 4.2/10
Shock resistance sine pulse	<ul style="list-style-type: none"> AC operation DC operation 	g/ms g/ms	9.8/5 and 5.9/10 9.8/5 and 5.9/10
Conductor cross-sections			
Short-circuit protection for contactors without overload relays			
For short-circuit protection for contactors with overload relays see "Protection Equipment --> Overload Relays" For short-circuit protection for fuseless load feeders see "Load Feeders, Motor Starters and Soft Starters -> 3RA Fuseless Load Feeders".			
Main circuit	<ul style="list-style-type: none"> Fuse links gL/gG LV HRC 3NA, DIAZED 5SB, NEOZED 5SE acc. to IEC 60947-4-1/EN 60947-4-1 Miniature circuit breakers (up to 230 V) with C characteristic Short-circuit current 1 kA, type of coordination "1" 	<ul style="list-style-type: none"> Type of coordination "1" Type of coordination "2" Weld-free³⁾ 	A 35 A 20 A 10 A 10
Auxiliary circuit	<ul style="list-style-type: none"> Fuse links gL/gG DIAZED 5SB, NEOZED 5SE (weld-free protection $I_k \geq 1$ kA) Miniature circuit breakers up to 230 V with C characteristic Short-circuit current $I_k < 400$ A 		A 10 A 6

¹⁾ For endurance of the main contacts see page 3/18.

²⁾ For conductor cross-sections see page 3/23.

³⁾ Test conditions according to IEC 60947-4-1.

3RT, 3TB, 3TF Contactors for Switching Motors

3RT10 contactors, 3-pole, 3 ... 250 kW

Contactors	Type Size	3RT10 1. S00	
Control			
Magnetic coil operating range			
• AC operation	50 Hz 60 Hz	0.8 ... 1.1 x U_s 0.85 ... 1.1 x U_s	
• DC operation	Up to 50 °C Up to 60 °C	0.8 ... 1.1 x U_s 0.85 ... 1.1 x U_s	
Power consumption of the magnetic coils (when coil is cold and 1.0 x U_s)			
AC operation, 50/60 Hz			
• Standard version	- Closing - P.f. - Closed - P.f.	VA VA	27/24.3 0.8/0.75 4.4/3.4 0.27/0.27
• AC operation, 50 Hz, USA/Canada	- Closing - P.f. for closing - Closed - P.f. for closed	VA VA	26.4 0.81 4.7 0.26
• AC operation, 60 Hz, USA/Canada	- Closing - P.f. for closing - Closed - P.f. for closed	VA VA	31.7 0.77 5.1 0.27
• DC operation	Closing = Closed	W	3.3
Permissible residual current of the electronics (with 0 signal)			
• AC operation			< 3 mA x (230 V/ U_s), the 3RT19 16-1GA00 additional load module is recommended for a higher residual current
• DC operation			< 10 mA x (24 V/ U_s), the 3RT19 16-1GA00 additional load module is recommended for a higher residual current
Operating times¹⁾			
Total break time = Opening delay + Arcing time			
• AC operation at 0.8 ... 1.1 x U_s	- Closing delay - Opening delay	ms ms	8 ... 35 4 ... 30
• DC operation at 0.85 ... 1.1 x U_s	- Closing delay - Opening delay	ms ms	25 ... 100 7 ... 10
• Arcing time		ms	10 ... 15
Operating times for 1.0 x U_s¹⁾			
• AC operation	- Closing delay - Opening delay	ms ms	10 ... 25 5 ... 30
• DC operation	- Closing delay - Opening delay	ms ms	30 ... 50 7 ... 9

¹⁾ The OFF-delay of the NO contact and the ON-delay of the NC contact are increased if the contactor coils are attenuated against voltage peaks (noise suppression diode 6 to 10 times; diode assemblies 2 to 6 times, varistor +2 to 5 ms).

Contactors	Type Size	3RT10 15 S00	3RT10 16 S00	3RT10 17 S00
Main circuit				
AC capacity				
Utilization category AC-1				
Switching resistive loads				
• Rated operational current I_e	At 40 °C up to 690 V At 60 °C up to 690 V	A A	18 16	22 20
• Rated power for AC loads ¹⁾ P.f. = 0.95 (at 60 °C)	230 V 400 V 500 V 690 V	kW kW kW kW	6.3 11 13.8 19	7.5 13 17 22
• Minimum conductor cross-section for loads with I_e	At 40 °C At 60 °C	mm ² mm ²	2.5 2.5	2.5 2.5
Utilization categories AC-2 and AC-3				
• Rated operational currents I_e	Up to 400 V 440 V 500 V 690 V	A A A A	7 7 5 4	9 9 6.5 5.2
• Rated power for slipping or squirrel-cage motors at 50 and 60 Hz	At 230 V 400 V 500 V 690 V	kW kW kW kW	2.2 3 3.5 4	3 4 4.5 5.5
Thermal load capacity	10 s current ²⁾	A	56	72

¹⁾ Industrial furnaces and electric heaters with resistance heating, etc. (increased power consumption on heating up has been taken into account).

²⁾ According to IEC 60947-4-1.
For rated values for various start-up conditions see "Protection Equipment -> Overload Relays".

3RT, 3TB, 3TF Contactors for Switching Motors

3RT10 contactors, 3-pole, 3 ... 250 kW

Contactor	Type Size		3RT10 15 S00	3RT10 16 S00	3RT10 17 S00
Main circuit					
AC capacity					
Power loss per conducting path					
		At $I_e/AC-3$ W	0.42	0.7	1.24
Utilization category AC-4 (for $I_a = 6 \times I_e$)¹⁾					
• Rated operational current I_e	Up to 400 V	A	6.5	8.5	8.5
• Rated power for squirrel-cage motors with 50 Hz and 60 Hz	Up to 400 V	kW	3	4	4
• The following applies to a contact endurance of about 200000 operating cycles:					
- Rated operational currents I_e	Up to 400 V	A	2.6	4.1	4.1
	690 V	A	1.8	3.3	3.3
- Rated power for squirrel-cage motors with 50 Hz and 60 Hz	At 230 V	kW	0.67	1.1	1.1
	400 V	kW	1.15	2	2
	500 V	kW	1.45	2	2
	690 V	kW	1.15	2.5	2.5
Utilization category AC-5a					
Switching gas discharge lamps, inductive ballast					
per main current path at 230 V					
• Uncorrected, rated power per lamp/rated operational current per lamp					
	L 18 W/0.37 A	Units	54	59	59
	L 36 W/0.43 A	Units	46	51	51
	L 58 W/0.67 A	Units	29	32	32
	L 80 W/0.79 A	Units	25	27	27
• DUO switching (two-lamp)					
	L 18 W/0.22 A	Units	90 (≅ 2 x 90 lamps)	100 (≅ 2 x 100 lamps)	100 (≅ 2 x 100 lamps)
	L 36 W/0.42 A	Units	47 (≅ 2 x 47 lamps)	52 (≅ 2 x 52 lamps)	52 (≅ 2 x 52 lamps)
	L 58 W/0.63 A	Units	31 (≅ 2 x 31 lamps)	34 (≅ 2 x 34 lamps)	34 (≅ 2 x 34 lamps)
	L 80 W/0.87 A	Units	22 (≅ 2 x 22 lamps)	25 (≅ 2 x 25 lamps)	25 (≅ 2 x 25 lamps)
Switching gas discharge lamps with correction					
per main current path at 230 V					
• Shunt compensation with inductive ballast, rated power per lamp/capacitance/ rated operational current per lamp					
	L 18 W/4.5 μF/0.11 A	Units	17	22	22
	L 36 W/4.5 μF/0.21 A	Units	16	22	22
	L 58 W/7.0 μF/0.32 A	Units	10	14	14
	L 80 W/7.0 μF/0.49 A	Units	6	9	9
• With solid-state ballast ²⁾ single lamp					
	L 18 W/6.8 μF/0.10 A	Units	49	63	63
	L 36 W/6.8 μF/0.18 A	Units	27	35	35
	L 58 W/10 μF/0.29 A	Units	16	23	23
	L 80 W/10 μF/0.43 A	Units	11	14	14
• With solid-state ballast ²⁾ two-lamp					
	L 18 W/10 μF/0.18 A	Units	27 (≅ 2 x 27 lamps)	35 (≅ 2 x 35 lamps)	35 (≅ 2 x 35 lamps)
	L 36 W/10 μF/0.35 A	Units	14 (≅ 2 x 14 lamps)	18 (≅ 2 x 18 lamps)	18 (≅ 2 x 18 lamps)
	L 58 W/22 μF/0.52 A	Units	9 (≅ 2 x 9 lamps)	12 (≅ 2 x 12 lamps)	12 (≅ 2 x 12 lamps)
	L 80 W/22 μF/0.86 A	Units	5 (≅ 2 x 5 lamps)	7 (≅ 2 x 7 lamps)	7 (≅ 2 x 7 lamps)
Utilization category AC-5b, switching incandescent lamps					
per main current path at 230/220 V					
Utilization category AC-6a					
switching AC transformers					
• Rated operational current I_e					
- For inrush current n = 20	Up to 400 V	A	3.6	5.1	7.2
- For inrush current n = 30	Up to 400 V	A	2.4	3.3	5.1
• Rated power P					
- For inrush current n = 20	At 230 V	kVA	1.4	2	2.9
	400 V	kVA	2.5	3.5	5
	500 V	kVA	3.3	4.6	6.2
	690 V	kVA	4.3	6	8.6
- For inrush current n = 30	At 230 V	kVA	1	1.3	2
	400 V	kVA	1.6	2.3	3.5
	500 V	kVA	2.2	3.1	4.6
	690 V	kVA	2.9	4	6

For deviating inrush current factors x, the power must be recalculated as follows:
 $P_x = P_{n,30} \cdot 30/x$

1) The data only apply to 3RT15 16 and 3RT15 17 (2 NO + 2 NC) up to a rated operational voltage of 400 V.

2) Depending on the electronic ballast used, higher lamp numbers are also possible.

3RT, 3TB, 3TF Contactors for Switching Motors

3RT10 contactors, 3-pole, 3 ... 250 kW

Contactors	Type Size	3RT10 15 S00	3RT10 16 S00	3RT10 17 S00
Main circuit				
<i>Load rating with DC</i>				
Utilization category DC-1				
Switching resistive loads ($L/R \leq 1$ ms)				
• Rated operational current I_e (at 60 °C)				
- 1 conducting path		Up to 24 V A 60 V A 110 V A 220 V A 440 V A 600 V A	15 15 1.5 0.6 0.42 0.42	20 20 2.1 0.8 0.6 0.6
- 2 conducting paths in series		Up to 24 V A 60 V A 110 V A 220 V A 440 V A 600 V A	15 15 8.4 1.2 1.6 0.5	20 20 12 1.6 0.8 0.7
- 3 conducting paths in series		Up to 24 V A 60 V A 110 V A 220 V A 440 V A 600 V A	15 15 15 15 0.9 0.7	20 20 20 20 1.3 1
Utilization category DC-3 and DC-5				
Shunt-wound and series-wound motors ($L/R \leq 15$ ms)				
• Rated operational current I_e (at 60 °C)				
- 1 conducting path		Up to 24 V A 60 V A 110 V A 220 V A 440 V A 600 V A	15 0.35 0.1 -- -- --	20 0.5 0.15 -- -- --
- 2 conducting paths in series		Up to 24 V A 60 V A 110 V A 220 V A 440 V A 600 V A	15 3.5 0.25 -- -- --	20 5 0.35 -- -- --
- 3 conducting paths in series		Up to 24 V A 60 V A 110 V A 220 V A 440 V A 600 V A	15 15 15 1.2 0.14 0.14	20 20 20 1.5 0.2 0.2

Switching frequency**Switching frequency z** in operating cycles/hour

• Contactors without overload relay	No-load switching frequency AC	h^{-1}	10000
	No-load switching frequency DC	h^{-1}	10000
Dependence of the switching frequency z' on the operational current I' and operational voltage U' : $z' = z \cdot (I_e/I') \cdot (400 V/U')^{1.5} \cdot 1/h$	Rated operation		
	AC-1 (AC/DC)	h^{-1}	1000
	AC-2 (AC/DC)	h^{-1}	750
	AC-3 (AC/DC)	h^{-1}	750
	AC-4 (AC/DC)	h^{-1}	250
• Contactors with overload relays (mean value)		h^{-1}	15

Conductor cross-sections**Main and auxiliary conductors:**

(1 or 2 conductors can be connected) For standard screwdriver size 2 and Pozidriv 2	• Solid	mm ²	
	• Finely stranded with end sleeve	mm ²	
	• Solid or stranded, AWG cables	AWG	
	• Terminal screw	M3	
	- Tightening torque	Nm	

 **Screw terminals**

2 x (0.5 ... 1.5) ¹⁾ ; 2 x (0.75 ... 2.5) ¹⁾ acc. to IEC 60947; max. 2 x (1 ... 4)
2 x (0.5 ... 1.5) ¹⁾ ; 2 x (0.75 ... 2.5) ¹⁾
2 x (20 ... 16) ¹⁾ ; 2 x (18 ... 14) ¹⁾ ; 1 x 12
0.8 ... 1.2 (7 ... 10.3 lb.in)

**Main and auxiliary conductors;
coil terminals:**

(1 or 2 conductors can be connected)	• Solid	mm ²	
	• Finely stranded with end sleeve	mm ²	
	• Finely stranded without end sleeve	mm ²	
	• AWG cables, solid or stranded	AWG	

 **Cage Clamp terminals**



2 x (0.25 ... 2.5)
2 x (0.25 ... 1.5)
2 x (0.25 ... 2.5)
2 x (24 ... 14)

For tools for opening Cage Clamp terminals see Catalog LV 1, Chapter 3, Accessories and Spare Parts.
Maximum external diameter of the conductor insulation: 3.6 mm.
For conductor cross-sections ≤ 1 mm² an "insulation stop" must be used, see Catalog LV 1, Chapter 3, "Accessories and Spare Parts".

¹⁾ If two different conductor cross-sections are connected to one clamping point, both cross-sections must lie in the range specified. If identical cross-sections are used, this restriction does not apply.

3RT, 3TB, 3TF Contactors for Switching Motors

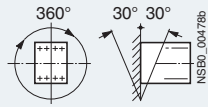
3RT10 contactors, 3-pole, 3 ... 250 kW

Contactor	Type Size	3RT10 23 S0	3RT10 24 S0	3RT10 25 S0	3RT10 26 S0
General data					
Permissible mounting position The contactors are designed for operation on a vertical mounting surface.	<ul style="list-style-type: none"> AC and DC operation 				
Upright mounting position:	<ul style="list-style-type: none"> AC operation DC operation 	 <p>Standard version</p> <p>Special version required, also applies to 3RT10 2...K.40. coupling relays.</p>			
Mechanical endurance	<ul style="list-style-type: none"> Basic units Basic unit with snap-on auxiliary switch block Solid-state compatible auxiliary switch block 	Operating cycles	10 million	10 million	5 million
Electrical endurance			1)		
Rated insulation voltage U_i (degree of pollution 3)		V	690		
Rated impulse withstand voltage U_{imp}		kV	6		
Protective separation between the coil and the main contacts (acc. to EN 60947-1, Appendix N)		V	400		
Mirror contacts	<ul style="list-style-type: none"> A mirror contact is an auxiliary NC contact that cannot be closed simultaneously with a NO main contact. 	<ul style="list-style-type: none"> 3RT10 2., 3RT13 2. (removable auxiliary switch block) 3RT10 2., 3RT13 2. (non-removable auxiliary switch block) 	Yes, acc. to EN 60947-4-1, Appendix F	Acc. to SUVA requirements on request	
Permissible ambient temperature	<ul style="list-style-type: none"> During operation During storage 	°C	-25 ... +60	°C	-55 ... +80
Degree of protection acc. to EN 60947-1, Appendix C			IP20, coil assembly IP20		
Touch protection acc. to EN 50274			Finger-safe		
Shock resistance rectangular pulse	<ul style="list-style-type: none"> AC operation DC operation 	g/ms	8.2/5 and 4.9/10	g/ms	10/5 and 7.5/10
Shock resistance sine pulse	<ul style="list-style-type: none"> AC operation DC operation 	g/ms	12.5/5 and 7.8/10	g/ms	15/5 and 10/10
Conductor cross-sections			2)		
Short-circuit protection for contactors without overload relays					
Main circuit	<ul style="list-style-type: none"> Fuse links gL/gG LV HRC 3NA, DIAZED 5SB, NEOZED 5SE acc. to IEC 60947-4-1/ EN 60947-4-1 		For short-circuit protection for contactors with overload relays see "Protection Equipment --> Overload Relays". For short-circuit protection for fuseless load feeders see "Load Feeders, Motor Starters and Soft Starters -> 3RA Fuseless Load Feeders".		
	<ul style="list-style-type: none"> Type of coordination "1" Type of coordination "2" Weld-free³⁾ 	A	63		100
		A	25		35
		A	10		16
	<ul style="list-style-type: none"> Miniature circuit breakers with C characteristic (short-circuit current 3 kA, type of coordination "1") 	A	25		32
Auxiliary circuit					
<ul style="list-style-type: none"> Fuse links gL/gG DIAZED 5SB, NEOZED 5SE (weld-free protection at $I_k \geq 1$ kA) 		A	10		
<ul style="list-style-type: none"> Miniature circuit breaker with C characteristic (short-circuit current $I_k < 400$ A) 		A	10		

1) For endurance of the main contacts see page 3/18.

2) For conductor cross-sections see page 3/28.

3) Test conditions according to IEC 60947-4-1.

3RT, 3TB, 3TF Contactors for Switching Motors

3RT10 contactors, 3-pole, 3 ... 250 kW

Contactors	Type Size	3RT10 2. S0	
Control			
Magnetic coil operating range	AC/DC	0.8 ... 1.1 x U_s	
Power consumption of the magnetic coils (when coil is cold and 1.0 x U_s)			
• AC operation, 50 Hz, standard version	- Closing	VA	61
	- P.f.		0.82
	- Closed	VA	7.8
	- P.f.		0.24
• AC operation, 50/60 Hz, standard version	- Closing	VA	64/63
	- P.f.		0.72/0.74
	- Closed	VA	8.4/6.8
	- P.f.		0.24/0.28
• AC operation, 50 Hz, USA/Canada	- Closing	VA	61
	- P.f.		0.82
	- Closed	VA	7.8
	- P.f.		0.24
• AC operation, 60 Hz, USA/Canada	- Closing	VA	69
	- P.f.		0.76
	- Closed	VA	7.5
	- P.f.		0.28
• DC operation	Closing = Closed	W	5.4
Permissible residual current of the electronics (with 0 signal)			
	• AC operation	mA	< 6 mA x (230 V/ U_s)
	• DC operation	mA	< 16 mA x (24 V/ U_s)
Operating times for 0.8 ... 1.1 x U_s¹⁾			
Total break time = Opening delay + Arcing time			
• AC operation	- Closing delay	ms	8 ... 44
	- Opening delay	ms	4 ... 20
• DC operation	- Closing delay	ms	50 ... 170
	- Opening delay	ms	13.5 ... 15.5
• Arcing time		ms	10
Operating times for 1.0 x U_s¹⁾			
• AC operation	- Closing delay	ms	10 ... 17
	- Opening delay	ms	4 ... 20
• DC operation	- Closing delay	ms	55 ... 85
	- Opening delay	ms	14 ... 15.5

¹⁾ The OFF-delay of the NO contact and the ON-delay of the NC contact are increased if the contactor coils are attenuated against voltage peaks (varistor +2 ms to 5 ms, diode assembly: 2 to 6 times).

Contactors	Type Size	3RT10 23 S0		3RT10 24 S0	3RT10 25 S0	3RT10 26 S0
Main circuit						
AC capacity						
Utilization category AC-1						
Switching resistive loads						
• Rated operational current I_e	At 40 °C up to 690 V	A	40			
	At 60 °C up to 690 V	A	35			
• Rated power for AC loads ¹⁾ P.f. = 0.95 (at 60 °C)	230 V	kW	13.3			
	400 V	kW	23			
	500 V	kW	29			
	690 V	kW	40			
• Minimum conductor cross-section for loads with I_e	At 40 °C	mm ²	10			
	At 60 °C	mm ²	10			
Utilization category AC-2 and AC-3						
• Rated operational currents I_e	Up to 400 V	A	9	12	17	25
	440 V	A	9	12	17	22
	500 V	A	6.5	12	17	18
	690 V	A	5.2	9	13	13
• Rated power for slipping or squirrel-cage motors at 50 Hz and 60 Hz	At 110 V	kW	1.1	1.5	2.2	3
	230 V	kW	3	3	4	5.5
	400 V	kW	4	5.5	7.5	11
	500 V	kW	4.5	7.5	10	11
	660 V/690 V	kW	5.5	7.5	11	11
Thermal load capacity	10 s current ²⁾	A	80	110	150	200
Power loss per conducting path	At I_e /AC-3	W	0.4	0.5	0.9	1.6

¹⁾ Industrial furnaces and electric heaters with resistance heating, etc. (increased power consumption on heating up has been taken into account).

²⁾ According to IEC 60947-4-1.
For rated values for various start-up conditions see "Protection Equipment -> Overload Relays".

3RT, 3TB, 3TF Contactors for Switching Motors

3RT10 contactors, 3-pole, 3 ... 250 kW

Contactors	Type Size		3RT10 23 S0	3RT10 24 S0	3RT10 25 S0	3RT10 26 S0
Main circuit						
AC capacity						
Utilization category AC-4 (for $I_a = 6 \times I_e$)						
• Rated operational current I_e	Up to 400 V	A	8.5	12.5	15.5	15.5
• Rated power for squirrel-cage motors with 50 Hz and 60 Hz	At 400 V	kW	4	5.5	7.5	7.5
• The following applies to a contact endurance of about 200000 operating cycles:						
- Rated operational currents I_e	Up to 400 V	A	4.1	5.5	7.7	9
	690 V	A	3.3	5.5	7.7	9
- Rated power for squirrel-cage motors with 50 Hz and 60 Hz	At 110 V	kW	0.5	0.73	1	1.2
	230 V	kW	1.1	1.5	2	2.5
	400 V	kW	2	2.6	3.5	4.4
	500 V	kW	2	3.3	4.6	5.6
	690 V	kW	2.5	4.6	6	7.7
Utilization category AC-5a						
Switching gas discharge lamps, inductive ballast						
Per main current path at 230 V ¹⁾						
• Rated power per lamp/rated operational current per lamp						
- Uncorrected	L 18 W/0.37 A	Units	108			
	L 36 W/0.43 A	Units	93			
	L 58 W/0.67 A	Units	59			
	L 80 W/0.79 A	Units	50			
- DUO switching (two-lamp)	L 18 W/0.22 A	Units	181 (≅ 2 x 181 lamps)			
	L 36 W/0.42 A	Units	95 (≅ 2 x 95 lamps)			
	L 58 W/0.63 A	Units	63 (≅ 2 x 63 lamps)			
	L 80 W/0.87 A	Units	45 (≅ 2 x 45 lamps)			
Switching gas discharge lamps with correction						
Per main current path at 230 V						
• Rated power per lamp/capacitance/rated operational current per lamp						
- Shunt compensation with inductive ballast	L 18 W/4.5 μF/0.11 A	Units	37		41	61
	L 36 W/4.5 μF/0.21 A	Units	30		30	51
	L 58 W/7.0 μF/0.32 A	Units	20		20	33
	L 80 W/7.0 μF/0.49 A	Units	13		13	22
- With solid-state ballast ²⁾ single lamp	L 18 W/6.8 μF/0.10 A	Units	105		119	175
	L 36 W/6.8 μF/0.18 A	Units	58		66	97
	L 58 W/10 μF/0.29 A	Units	36		41	60
	L 80 W/10 μF/0.43 A	Units	24		27	40
- With solid-state ballast ²⁾ two-lamp	L 18 W/10 μF/0.18 A	Units	58 (≅ 2 x 58 lamps)		66 (≅ 2 x 66 l.)	97 (≅ 2 x 97 l.)
	L 36 W/10 μF/0.35 A	Units	30 (≅ 2 x 30 lamps)		34 (≅ 2 x 34 l.)	50 (≅ 2 x 50 l.)
	L 58 W/22 μF/0.52 A	Units	20 (≅ 2 x 20 lamps)		22 (≅ 2 x 22 l.)	33 (≅ 2 x 33 l.)
	L 80 W/22 μF/0.86 A	Units	12 (≅ 2 x 12 lamps)		13 (≅ 2 x 13 l.)	20 (≅ 2 x 20 l.)
Utilization category AC-5b, switching incandescent lamps						
per main current path at 230/220 V						
		kW	2.8		3.2	4.7
Utilization category AC-6a						
switching AC transformers						
• Rated operational current I_e						
- For inrush current n = 20	Up to 400 V	A	11.4			20.2
- For inrush current n = 30	Up to 400 V	A	7.6			13.5
• Rating P						
- For inrush current n = 20	At 230 V	kVA	4.5			8
	400 V	kVA	7.9			13.9
	500 V	kVA	9.9			15.5
	690 V	kVA	13.6			15.5
- For inrush current n = 30	At 230 V	kVA	3			5.4
	400 V	kVA	5.2			9.3
	500 V	kVA	6.6			11.7
	690 V	kVA	9.1			15.5
For deviating inrush current factors x, the power must be recalculated as follows: $P_x = P_{n30} \cdot 30/x$						
Utilization category AC-6b,						
switching low-inductance (low-loss, metallized dielectric) AC capacitors						
• Rated operational currents I_e	Up to 400 V	A	5.8			10.8
• Rated power for single capacitors or banks of capacitors (minimum inductance of 6 μH between capacitors connected in parallel) at 50 Hz, 60 Hz and	At 230 V	kvar	2.5			4
	400 V	kvar	4			7.5
	500 V	kvar	4			7.5
	690 V	kvar	4			7.5

¹⁾ For $I_e/AC-1 = 35$ A (60 °C) and the corresponding minimum conductor cross-section 10 mm².

²⁾ Depending on the electronic ballast used, higher lamp numbers are also possible.



3RT, 3TB, 3TF Contactors for Switching Motors



3RT10 contactors, 3-pole, 3 ... 250 kW

Contactors	Type Size	3RT10 23 S0	3RT10 24 S0	3RT10 25 S0	3RT10 26 S0
Main circuit					
<i>Load rating with DC</i>					
Utilization category DC-1					
Switching resistive loads ($L/R \leq 1$ ms)					
• Rated operational current I_g (at 60 °C)					
- 1 conducting path		Up to 24 V A	35		
		60 V A	20		
		110 V A	4.5		
		220 V A	1		
		440 V A	0.4		
		600 V A	0.25		
- 2 conducting paths in series		Up to 24 V A	35		
		60 V A	35		
		110 V A	35		
		220 V A	5		
		440 V A	1		
		600 V A	0.8		
- 3 conducting paths in series		Up to 24 V A	35		
		60 V A	35		
		110 V A	35		
		220 V A	35		
		440 V A	2.9		
		600 V A	1.4		
Utilization category DC-3 and DC-5					
Shunt-wound and series-wound motors ($L/R \leq 15$ ms)					
• Rated operational current I_g (at 60 °C)					
- 1 conducting path		Up to 24 V A	20		
		60 V A	5		
		110 V A	2.5		
		220 V A	1		
		440 V A	0.09		
		600 V A	0.06		
- 2 conducting paths in series		Up to 24 V A	35		
		60 V A	35		
		110 V A	15		
		220 V A	3		
		440 V A	0.27		
		600 V A	0.16		
- 3 conducting paths in series		Up to 24 V A	35		
		60 V A	35		
		110 V A	35		
		220 V A	10		
		440 V A	0.6		
		600 V A	0.6		
Switching frequency					
Switching frequency z in operating cycles/hour					
• Contactors without overload relays					
	No-load switching frequency AC	h^{-1}	5000		
	No-load switching frequency DC	h^{-1}	1500		
Dependence of the switching frequency z' on the operational current I' and operational voltage U' :					
$z' = z \cdot (I_g/I') \cdot (400 V/U')^{1.5} \cdot 1/h$					
	AC-1 (AC/DC)	h^{-1}	1000		
	AC-2 (AC/DC)	h^{-1}	1000		750
	AC-3 (AC/DC)	h^{-1}	1000		750
	AC-4 (AC/DC)	h^{-1}	300		250
• Contactors with overload relays (mean value)					
		h^{-1}	15		

3RT, 3TB, 3TF Contactors for Switching Motors

3RT10 contactors, 3-pole, 3 ... 250 kW

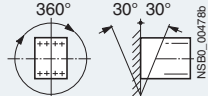
Contactors	Type Size	3RT10 23 S0	3RT10 24 S0	3RT10 25 S0	3RT10 26 S0
Conductor cross-sections (1 or 2 conductors connectable)					
Main conductors		 Screw terminals			
Conductor cross-section		mm ² 2 x (1 ... 2.5) ¹⁾ ; 2 x (2.5 ... 6) ¹⁾ acc. to IEC 60947; max. 1 x 10			
• Solid		mm ² 2 x (1 ... 2.5) ¹⁾ ; 2 x (2.5 ... 6) ¹⁾			
• Finely stranded with end sleeve		mm ² 2 x (1 ... 2.5) ¹⁾ ; 2 x (2.5 ... 6) ¹⁾			
• AWG cables, solid		AWG 2 x (16 ... 12)			
• AWG cables, solid or stranded		AWG 2 x (14 ... 10)			
• AWG cables, stranded		AWG 1 x 8			
• Terminal screws		M4 (Pozidriv size 2)			
- Tightening torque		Nm 2 ... 2.5 (18 ... 22 lb.in)			
Auxiliary conductors		 Cage Clamp terminals			
Conductor cross-section		mm ² 2 x (0.5 ... 1.5) ¹⁾ ; 2 x (0.75 ... 2.5) ¹⁾ acc. to IEC 60947; max. 2 x (0.75 ... 4)			
• Solid		mm ² 2 x (0.5 ... 1.5) ¹⁾ ; 2 x (0.75 ... 2.5) ¹⁾			
• Finely stranded with end sleeve		mm ² 2 x (0.5 ... 1.5) ¹⁾ ; 2 x (0.75 ... 2.5) ¹⁾			
• solid or stranded AWG (2 x)		AWG 2 x (20 ... 16) ¹⁾ ; 2 x (18 ... 14) ¹⁾ ; 1 x 12			
• Terminal screws		M3			
- Tightening torque		Nm 0.8 ... 1.2 (7 ... 10.3 lb.in)			
Auxiliary conductors		 Cage Clamp terminals			
• Solid		mm ² 2 x (0.25 ... 2.5)			
• Finely stranded with end sleeve		mm ² 2 x (0.25 ... 1.5)			
• Finely stranded without end sleeve		mm ² 2 x (0.25 ... 2.5)			
• AWG cables, solid or stranded		AWG 2 x (24 ... 14)			
1) If two different conductor cross-sections are connected to one clamping point, both cross-sections must lie in the range specified. If identical cross-sections are used, this restriction does not apply.					

Contactors	Type Size	3RT10 34 S2	3RT10 35 S2	3RT10 36 S2
General data				
Permissible mounting position The contactors are designed for operation on a vertical mounting surface.	• AC and DC operation			
		For DC operation and 22.5 ° inclination towards the front, operating range 0.85 ... 1.1 x U _s		
Upright mounting position:	• AC and DC operation			
		Special version required.		
Mechanical endurance	• Basic units	Operating cycles	10 million	
	• Basic unit with snap-on auxiliary switch block		10 million	
	• Solid-state compatible auxiliary switch block		5 million	
Electrical endurance			1)	
Rated insulation voltage U _i (degree of pollution 3)		V	690	
Rated impulse withstand voltage U _{imp}		kV	6	
Protective separation between the coil and the main contacts acc. to EN 60947-1, Appendix N		V	400	
Mirror contacts	• A mirror contact is an auxiliary NC contact that cannot be closed simultaneously with a NO main contact.	- 3RT10 3., 3RT13 3. (removable auxiliary switch block) - 3RT10 3., 3RT13 3. (non-removable auxiliary switch block)	Yes, acc. to EN 60947-4-1, Appendix F Acc. to SUVA requirements on request.	
Permissible ambient temperature	• During operation	°C	-25 ... +60	
	• During storage	°C	-55 ... +80	
Degree of protection acc. to EN 60947-1, Appendix C			IP20 (terminal compartment IP00), AC coil assembly IP40, DC coil assembly IP30 Finger-safe	
Touch protection acc. to EN 50274				
Shock resistance				
• Rectangular pulse	AC and DC operation	g/ms	10/5 and 5/10	
• Sine pulse	AC and DC operation	g/ms	15/5 and 8/10	
Conductor cross-sections			2)	

1) For endurance of the main contacts see page 3/19.

2) For conductor cross-sections see page 3/32.

3RT, 3TB, 3TF Contactors for Switching Motors

3RT10 contactors, 3-pole, 3 ... 250 kW

Contactors	Type Size		3RT10 34 S2	3RT10 35 S2	3RT10 36 S2
Short-circuit protection for contactors without overload relays					
			For short-circuit protection for contactors with overload relays see "Protection Equipment --> Overload Relays". For short-circuit protection for fuseless load feeders see "Load Feeders, Motor Starters and Soft Starters -> 3RA Fuseless Load Feeders".		
Main circuit					
Fuse links, gL/gG					
LV HRC 3NA, DIAZED 5SB, NEOZED 5SE					
acc. to IEC 60947-4-1/EN 60947-4-1					
	• Type of coordination "1"	A	125	125	160
	• Type of coordination "2"	A	63	63	80
	• Weld-free ¹⁾	A	16	16	50
Auxiliary circuit					
• Fuse links gL/gG	DIAZED 5SB, NEOZED 5SE (weld-free protection at $I_k \geq 1$ kA)	A	10		
• Miniature circuit breakers with C characteristic (short-circuit current $I_k \leq 400$ A)		A	10		
Control					
Magnetic coil operating range		AC/DC	0.8 ... 1.1 x U_s		
Power consumption of the magnetic coils (when coil is cold and 1.0 x U_s)					
• AC operation, 50 Hz, standard version	- Closing	VA	104	145	
	- P.f.		0.78	0.79	
	- Closed	VA	9.7	12.5	
	- P.f.		0.42	0.36	
• AC operation, 50/60 Hz, standard version	- Closing	VA	127/113	170/155	
	- P.f.		0.73/0.69	0.76/0.72	
	- Closed	VA	11.3/9.5	15/11.8	
	- P.f.		0.41/0.42	0.35/0.38	
• AC operation, 50 Hz, USA/Canada	- Closing	VA	108	150	
	- P.f.		0.76	0.77	
	- Closed	VA	9.6	12.5	
	- P.f.		0.42	0.35	
• AC operation, 60 Hz, USA/Canada	- Closing	VA	120	166	
	- P.f.		0.7	0.71	
	- Closed	VA	10.1	12.6	
	- P.f.		0.42	0.37	
• DC operation	Closing = Closed	W	13.3	13.3	
Permissible residual current of the electronics (with 0 signal)					
	• AC operation	mA	< 12 mA x (230 V/ U_s)		< 18 mA x (230 V/ U_s)
	• DC operation	mA	< 38 mA x (24 V/ U_s)		< 38 mA x (24 V/ U_s)
Operating times for 0.8 ... 1.1 x U_s²⁾ (Total break time = Opening delay + Arcing time)					
• AC operation	- Closing delay	ms	11 ... 30	10 ... 24	
	- Opening delay	ms	7 ... 10	7 ... 10	
• DC operation	- Closing delay	ms	50 ... 95	60 ... 100	
	- Opening delay	ms	20 ... 30	20 ... 25	
• Arcing time		ms	10	10	
Operating times for 1.0 x U_s²⁾					
• AC operation	- Closing delay	ms	13 ... 22	12 ... 20	
	- Opening delay	ms	7 ... 10	7 ... 10	
• DC operation	- Closing delay	ms	60 ... 75	70 ... 85	
	- Opening delay	ms	20 ... 30	20 ... 25	

¹⁾ Test conditions according to IEC 60947-4-1.

²⁾ The OFF-delay of the NO contact and the ON-delay of the NC contact are increased if the contactor coils are attenuated against voltage peaks (varistor +2 ms to 5 ms, diode assembly: 2 to 6 times).

3RT, 3TB, 3TF Contactors for Switching Motors

3RT10 contactors, 3-pole, 3 ... 250 kW

Contactors	Type Size		3RT10 34 S2	3RT10 35 S2	3RT10 36 S2
Main circuit					
AC capacity					
Utilization category AC-1					
Switching resistive loads					
• Rated operational currents I_e	At 40 °C up to 690 V	A	50	60	60
	At 60 °C up to 690 V	A	45	55	55
• Rated power for AC loads ¹⁾	230 V	kW	18	22	22
P.f. = 0.95 (at 60 °C)	400 V	kW	31	38	38
	500 V	kW	39	46	46
	690 V	kW	54	66	66
• Minimum conductor cross-section for loads with I_e	At 40 °C	mm ²	16	16	16
	At 60 °C	mm ²	10	16	16
Utilization category AC-2 and AC-3					
• Rated operational currents I_e	Up to 500 V	A	32	40	50
	690 V	A	20	24	24
• Rated power for slipping or squirrel-cage motors at 50 and 60 Hz	230 V	kW	7.5	11	15
	400 V	kW	15	18.5	22
	500 V	kW	18.5	22	30
	690 V	kW	18.5	22	22
Thermal load capacity					
	10 s current ²⁾	A	320	400	400
Power loss per conducting path					
	At $I_e/AC-3$	W	1.8	2.6	5
Utilization category AC-4 (for $I_a = 6 \times I_e$)					
• Rated operational current I_e	Up to 400 V	A	29	35	41
• Rated power for squirrel-cage motors with 50 Hz and 60 Hz	At 400 V	kW	15	18.5	22
• The following applies to a contact endurance of about 200000 operating cycles:					
- Rated operational currents I_e	Up to 400 V	A	15.6	18.5	24
	690 V	A	15.6	18.5	24
- Rated power for squirrel-cage motors with 50 Hz and 60 Hz	230 V	kW	4.7	5.4	7.3
	400 V	kW	8.2	9.5	12.6
	500 V	kW	9.8	11.8	15.8
	690 V	kW	13	15.5	21.8
Utilization category AC-5a					
Switching gas discharge lamps, inductive ballast					
Per main current path at 230 V					
• Uncorrected, rated power per lamp/rated operational current per lamp					
	L 18 W/0.37 A	Units	135	162	162
	L 36 W/0.43 A	Units	116	139	139
	L 58 W/0.67 A	Units	74	89	89
	L 80 W/0.79 A	Units	63	75	75
• DUO switching (two-lamp)					
	L 18 W/0.22 A	Units	227 (≅ 2 x 227 lamps)	272 (≅ 2 x 272 lamps)	272 (≅ 2 x 272 lamps)
	L 36 W/0.42 A	Units	119 (≅ 2 x 119 lamps)	142 (≅ 2 x 142 lamps)	142 (≅ 2 x 142 lamps)
	L 58 W/0.63 A	Units	79 (≅ 2 x 79 lamps)	95 (≅ 2 x 95 lamps)	95 (≅ 2 x 95 lamps)
	L 80 W/0.87 A	Units	57 (≅ 2 x 57 lamps)	68 (≅ 2 x 68 lamps)	68 (≅ 2 x 68 lamps)
Switching gas discharge lamps with correction					
Per main current path at 230 V					
• Shunt compensation with inductive ballast, rated power per lamp/capacitance/rated operational current per lamp					
	L 18 W/4.5 μF/0.11 A	Units	78	98	123
	L 36 W/4.5 μF/0.21 A	Units	78	98	123
	L 58 W/7 μF/0.32 A	Units	50	63	79
	L 80 W/7 μF/0.49 A	Units	50	63	73
• With solid-state ballast ³⁾ single lamp					
	L 18 W/6.8 μF/0.10 A	Units	224	280	350
	L 36 W/6.8 μF/0.18 A	Units	124	155	194
	L 58 W/10 μF/0.29 A	Units	77	96	120
	L 80 W/10 μF/0.43 A	Units	52	65	81
• With solid-state ballast ³⁾ two-lamp					
	L 18 W/10 μF/0.18 A	Units	124 (≅ 2 x 124 lamps)	155 (≅ 2 x 155 lamps)	194 (≅ 2 x 194 lamps)
	L 36 W/10 μF/0.35 A	Units	64 (≅ 2 x 64 lamps)	80 (≅ 2 x 80 lamps)	100 (≅ 2 x 100 lamps)
	L 58 W/22 μF/0.52 A	Units	43 (≅ 2 x 43 lamps)	54 (≅ 2 x 54 lamps)	67 (≅ 2 x 67 lamps)
	L 80 W/22 μF/0.86 A	Units	26 (≅ 2 x 26 lamps)	32 (≅ 2 x 32 lamps)	40 (≅ 2 x 40 lamps)

1) Industrial furnaces and electric heaters with resistance heating, etc. (increased power consumption on heating up has been taken into account).

2) According to IEC 60947-4-1.
For rated values for various start-up conditions see "Protection Equipment --> Overload Relays".

3) Depending on the electronic ballast used, higher lamp numbers are also possible.

3RT, 3TB, 3TF Contactors for Switching Motors





3RT10 contactors, 3-pole, 3 ... 250 kW

Contactors	Type Size		3RT10 34 S2	3RT10 35 S2	3RT10 36 S2
Main circuit					
AC capacity					
Utilization category AC-5b Switching incandescent lamps		kW	6.0	7.6	9.5
Per main current path at 230/220 V					
Utilization category AC-6a switching AC transformers					
• Rated operational current I_e					
- For inrush current n = 20	Up to 400 V	A	31	36.5	43.2
- For inrush current n = 30	Up to 400 V	A	20.7	24.3	28.8
• Rating P					
- For inrush current n = 20	At 230 V	kVA	12.3	14.5	17.2
	400 V	kVA	21.5	25.3	29.9
	500 V	kVA	26.8	31.6	37.4
	690 V	kVA	23.9	28.7	28.7
- For inrush current n = 30	230 V	kVA	8.2	9.7	11.5
	400 V	kVA	14.3	16.8	20
	500 V	kVA	17.9	21	24.9
	690 V	kVA	23.9	28.7	28.7
For deviating inrush current factors x, the power must be recalculated as follows. $P_x = P_{n30} \cdot 30/x$					
Utilization category AC-6b Switching low-inductance (low-loss, metallized dielectric) AC capacitors					
Ambient temperature 40 °C					
• Rated operational currents I_e	Up to 400 V	A	29	36	36
• Rated power for single capacitors or banks of capacitors (minimum inductance of 20 µH between capacitors connected in parallel) at 50 Hz, 60 Hz and	At 230 V	kvar	12	15	15
	400 V	kvar	20	25	25
	525 V	kvar	25	33	33
	690 V	kvar	20	25	25
Load rating with DC					
Utilization category DC-1 Switching resistive loads ($L/R < 1$ ms)					
• Rated operational current I_e (at 60 °C)					
- 1 conducting path	Up to 24 V	A	45	55	55
	60 V	A	20	23	23
	110 V	A	4.5	4.5	4.5
	220 V	A	2	2	2
	440 V	A	0.4	0.4	0.4
	600 V	A	0.25	0.25	0.25
- 2 conducting paths in series	Up to 24 V	A	45	55	55
	60 V	A	45	45	45
	110 V	A	45	45	45
	220 V	A	5	5	5
	440 V	A	1	1	1
	600 V	A	0.8	0.8	0.8
- 3 conducting paths in series	Up to 24 V	A	45	55	55
	60 V	A	45	55	55
	110 V	A	45	55	55
	220 V	A	45	45	45
	440 V	A	2.9	2.9	2.9
	600 V	A	1.4	1.4	1.4
Utilization category DC-3 and DC-5 Shunt-wound and series-wound motors ($L/R \leq 15$ ms)					
• Rated operational current I_e (at 60 °C)					
- 1 conducting path	Up to 24 V	A	35	35	35
	60 V	A	6	6	6
	110 V	A	2.5	2.5	2.5
	220 V	A	2	2	2
	440 V	A	0.1	0.1	0.1
	600 V	A	0.06	0.06	0.06
- 2 conducting paths in series	Up to 24 V	A	45	55	55
	60 V	A	45	45	45
	110 V	A	25	25	25
	220 V	A	5	5	5
	440 V	A	0.27	0.27	0.27
	600 V	A	0.16	0.16	0.16
- 3 conducting paths in series	Up to 24 V	A	45	55	55
	60 V	A	45	55	55
	110 V	A	45	55	55
	220 V	A	25	25	25
	440 V	A	0.6	0.6	0.6
	600 V	A	0.6	0.6	0.6

3RT, 3TB, 3TF Contactors for Switching Motors

3RT10 contactors, 3-pole, 3 ... 250 kW

Contactors	Type Size		3RT10 34 S2	3RT10 35 S2	3RT10 36 S2
Switching frequency					
Switching frequency z in operating cycles/hour					
• Contactors without overload relays	No-load switching frequency AC	h ⁻¹	5000	5000	5000
	No-load switching frequency DC	h ⁻¹	1500	1500	1500
Dependence of the switching frequency z' on the operational current I' and operational voltage U': $z' = z \cdot (I_e/I') \cdot (400 V/U')^{1.5} \cdot 1/h$	AC-1 (AC/DC)	h ⁻¹	1200	1200	1000
	AC-2 (AC/DC)	h ⁻¹	750	600	400
	AC-3 (AC/DC)	h ⁻¹	1000	1000	800
	AC-4 (AC/DC)	h ⁻¹	250	300	300
• Contactors with overload relays (mean value)		h ⁻¹	15	15	15

Contactors	Type Size		3RT10 3. S2	
Conductor cross-sections (1 or 2 conductors connectable)				
Front clamping point connected 	Main conductors: With box terminal		 Screw terminals	
	<ul style="list-style-type: none"> Finely stranded with end sleeve Finely stranded without end sleeve Stranded Solid Ribbon cable conductors (number x width x thickness) AWG cables, solid or stranded 	mm ² mm ² mm ² mm ² mm AWG		0.75 ... 25 0.75 ... 25 0.75 ... 35 0.75 ... 16 6 x 9 x 0.8 18 ... 2
Rear clamping point connected 	<ul style="list-style-type: none"> Finely stranded with end sleeve Finely stranded without end sleeve Stranded Solid Ribbon cable conductors (number x width x thickness) AWG cables, solid or stranded 		mm ² mm ² mm ² mm ² mm AWG	0.75 ... 25 0.75 ... 25 0.75 ... 35 0.75 ... 16 6 x 9 x 0.8 18 ... 2
	<ul style="list-style-type: none"> Finely stranded with end sleeve Finely stranded without end sleeve Stranded Solid Ribbon cable conductors (number x width x thickness) AWG cables, solid or stranded Terminal screw - Tightening torque 		mm ² mm ² mm ² mm ² mm AWG Nm	2 x (0.75 ... 16) 2 x (0.75 ... 16) 2 x (0.75 ... 25) 2 x (0.75 ... 16) 2 x (6 x 9 x 0.8) 2 x (18 ... 2) M6 (Pozidriv size 2) 3 ... 4.5 (27 ... 40 lb.in)
Both clamping points connected 	<ul style="list-style-type: none"> Solid Finely stranded with end sleeve AWG cables, solid or stranded Terminal screw - Tightening torque 		mm ² mm ² AWG Nm	2 x (0.5 ... 1.5) ¹⁾ ; 2 x (0.75 ... 2.5) ¹⁾ acc. to IEC 60947; max. 2 x (0.75 ... 4) 2 x (0.5 ... 1.5) ¹⁾ ; 2 x (0.75 ... 2.5) ¹⁾ 2 x (20 ... 16) ¹⁾ ; 2 x (18 ... 14) ¹⁾ ; 1 x 12 M3 0.8 ... 1.2 (7 ... 10.3 lb.in)
	<ul style="list-style-type: none"> Solid Finely stranded with end sleeve Finely stranded without end sleeve AWG cables, solid or stranded 		mm ² mm ² mm ²	 Cage Clamp terminals 2 x (0.25 ... 2.5) 2 x (0.25 ... 1.5) 2 x (0.25 ... 2.5) 2 x (24 ... 14)

For tools for opening Cage Clamp terminals see Catalog LV 1, Chapter 3, Accessories and Spare Parts.

Maximum external diameter of the conductor insulation: 3.6 mm. For conductor cross-sections ≤ 1 mm² an "insulation stop" must be used, see Catalog LV 1, Chapter 3, "Accessories and Spare Parts".

¹⁾ If two different conductor cross-sections are connected to one clamping point, both cross-sections must lie in the range specified. If identical cross-sections are used, this restriction does not apply.

3RT, 3TB, 3TF Contactors for Switching Motors

3RT10 contactors, 3-pole, 3 ... 250 kW

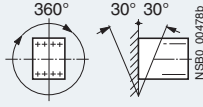
Contactors	Type Size		3RT10 44 S3	3RT10 45 S3	3RT10 46 S3
General data					
Permissible mounting position The contactors are designed for operation on a vertical mounting surface.	• AC and DC operation		 <p>For DC operation and 22.5° inclination towards the front, operating range 0.85 ... 1.1 x U_s</p> <p>NSB0_00477a Special version required.</p>		
Upright mounting position:	• AC operation		--		
	• DC operation		--		
Mechanical endurance	• Basic units	Operating cycles	10 million		
	• Basic unit with snap-on auxiliary switch block		10 million		
	• Solid-state compatible auxiliary switch block		5 million		
Electrical endurance			1)		
Rated insulation voltage U_i (degree of pollution 3)		V	1000		
Rated impulse withstand voltage U_{imp}		kV	6		
Protective separation between the coil and the main contacts acc. to EN 60947-1, Appendix N		V	690		
Mirror contacts			Yes, acc. to EN 60947-4-1, Appendix F		
• A mirror contact is an auxiliary NC contact that cannot be closed simultaneously with a NO main contact.	<ul style="list-style-type: none"> - 3RT10 4., 3RT13 4., 3RT14 4. (removable auxiliary switch block) - 3RT10 4., 3RT13 4., 3RT14 4. (non-removable auxiliary switch block) 		Acc. to Swiss regulations (SUVA) on request.		
Permissible ambient temperature	• During operation	°C	-25 ... +60		
	• During storage	°C	-55 ... +80		
Degree of protection acc. to EN 60947-1, Appendix C			IP20 (terminal compartment IP00), AC coil assembly IP40, DC coil assembly IP30 Finger-safe		
Touch protection acc. to EN 50274			Finger-safe		
Shock resistance					
• Rectangular pulse	AC and DC operation	g/ms	6.8/5 and 4/10		
• Sine pulse	AC and DC operation	g/ms	10.6/5 and 6.2/10		
Conductor cross-sections			2)		
Short-circuit protection for contactors without overload relays					
Main circuit			For short-circuit protection for contactors with overload relays see "Protection Equipment --> Overload Relays". For short-circuit protection for fuseless load feeders see "Load Feeders, Motor Starters and Soft Starters -> 3RA Fuseless Load Feeders".		
• Fuse links gL/gG LV HRC 3NA, DIAZED 5SB, NEOZED 5SE acc. to IEC 60947-4-1/ EN 60947-4-1					
	- Type of coordination "1"	A	250	250	
	- Type of coordination "2"	A	125	160	
	- Weld-free ³⁾	A	63	100	
Auxiliary circuit					
• Fuse links gL/gG DIAZED 5SB, NEOZED 5SE (weld-free protection at $I_k \geq 1$ kA)		A	10		
• Miniature circuit breakers with C characteristic (short-circuit current $I_k < 400$ A)		A	10		

¹⁾ For endurance of the main contacts see page 3/19.

²⁾ For conductor cross-sections see page 3/37.

³⁾ Test conditions according to IEC 60947-4-1.

3RT, 3TB, 3TF Contactors for Switching Motors

3RT10 contactors, 3-pole, 3 ... 250 kW

Contactors	Type Size		3RT10 44 S3	3RT10 45 S3	3RT10 46 S3
Control					
Magnetic coil operating range	AC/DC		0.8 ... 1.1 x U_s		
Power consumption of the magnetic coils (when coil is cold and 1.0 x U_s)					
• AC operation, 50 Hz, standard version	- Closing	VA	218	270	
	- P.f.		0.61	0.68	
• AC operation, 50/60 Hz, standard version	- Closing	VA	247/211	298/274	
	- P.f.		0.62/0.57	0.7/0.62	
• AC operation, 50 Hz, USA/Canada	- Closing	VA	218	270	
	- P.f.		0.61	0.68	
• AC operation, 60 Hz, USA/Canada	- Closing	VA	232	300	
	- P.f.		0.55	0.52	
• DC operation	- Closing	VA	21	22	
	- P.f.		0.26	0.27	
• DC operation	- Closing	VA	21	22	
	- P.f.		0.26	0.27	
• DC operation	- Closing	VA	20	21	
	- P.f.		0.28	0.29	
• DC operation	- Closing	VA	15	15	
	- P.f.		0.28	0.29	
Permissible residual current of the electronics (with 0 signal)					
• AC operation			< 25 mA x (230 V/ U_s)		
• DC operation			< 43 mA x (24 V/ U_s)		
Operating times for 0.8 ... 1.1 x U_s¹⁾					
Total break time = Opening delay + Arcing time					
• AC operation	- Closing delay	ms	16 ... 57	17 ... 90	
	- Opening delay	ms	10 ... 19	10 ... 25	
• DC operation	- Closing delay	ms	90 ... 230	90 ... 230	
	- Opening delay	ms	14 ... 20	14 ... 20	
• Arcing time		ms	10 ... 15	10 ... 15	
Operating times for 1.0 x U_s¹⁾					
• AC operation	- Closing delay	ms	18 ... 34	18 ... 30	
	- Opening delay	ms	11 ... 18	11 ... 23	
• DC operation	- Closing delay	ms	100 ... 120	100 ... 120	
	- Opening delay	ms	16 ... 20	16 ... 20	
Main circuit					
AC capacity					
Utilization category AC-1					
Switching resistive loads					
• Rated operational currents I_e	At 40 °C up to 690 V A	1000 V A	100	120	120
		1000 V A	50	60	70
	At 60 °C up to 690 V A	1000 V A	90	100	100
		1000 V A	40	50	60
• Rated output of AC loads ²⁾ P.f. = 0.95 (at 60 °C)	At 230 V kW	34	38	38	
	400 V kW	59	66	66	
	500 V kW	74	82	82	
	690 V kW	102	114	114	
	1000 V kW	66	82	98	
• Minimum conductor cross-section for loads with I_e	At 40 °C mm ²	35	50	50	
	At 60 °C mm ²	35	35	35	
Utilization categories AC-2 and AC-3					
• Rated operational currents I_e	Up to 500 V A	65	80	95	
	690 V A	47	58	58	
	1000 V A	25	30	30	
• Rated power of slipping or squirrel-cage motors at 50 and 60 Hz	At 230 V kW	18.5	22	22	
	400 V kW	30	37	45	
	500 V kW	37	45	55	
	690 V kW	45	55	55	
	1000 V kW	30	37	37	
Thermal load capacity					
	10 s current ³⁾ A	600	760	760	
Power loss per conducting path					
	At I_e /AC-3 W	4.6	7.7	10.8	

1) The OFF-delay of the NO contact and the ON-delay of the NC contact are increased if the contactor coils are attenuated against voltage peaks (varistor +2 ms to 5 ms, diode assembly: 2 to 6 times).

2) Industrial furnaces and electric heaters with resistance heating, etc. (increased power consumption on heating up has been taken into account).

3) According to IEC 60947-4-1.
For rated values for various start-up conditions see "Protection Equipment --> Overload Relays".

3RT, 3TB, 3TF Contactors for Switching Motors

3RT10 contactors, 3-pole, 3 ... 250 kW

Contactors	Type Size		3RT10 44 S3	3RT10 45 S3	3RT10 46 S3
Main circuit					
AC capacity					
Utilization category AC-4 (for $I_a = 6 \times I_e$)					
• Rated operational current I_e	Up to 400 V	A	55	66	80
• Rated power for squirrel-cage motors with 50 Hz and 60 Hz	At 400 V	kW	30	37	45
• The following applies to a contact endurance of about 200000 operating cycles:					
- Rated operational currents I_e	Up to 400 V	A	28	34	42
	690 V	A	28	34	42
	1000 V	A	20	23	23
- Rated power for squirrel-cage motors with 50 Hz and 60 Hz	At 230 V	kW	8.7	10.4	12
	400 V	kW	15.1	17.9	22
	500 V	kW	18.4	22.4	27
	690 V	kW	25.4	30.9	38
	1000 V	kW	22	30	30
Utilization category AC-5a					
Switching gas discharge lamps, inductive ballast					
Per main current path at 230 V					
• Uncorrected, rated power per lamp/rated operational current per lamp					
	L 18 W/0.37 A	Units	270	324	
	L 36 W/0.43 A	Units	232	279	
	L 58 W/0.67 A	Units	149	179	
	L 80 W/0.79 A	Units	126	151	
• DUO switching (two-lamp)					
	L 18 W/0.21 A	Units	454 (≅ 2 x 454 lamps)	545 (≅ 2 x 545 lamps)	
	L 36 W/0.42 A	Units	238 (≅ 2 x 238 lamps)	285 (≅ 2 x 285 lamps)	
	L 58 W/0.63 A	Units	158 (≅ 2 x 158 lamps)	190 (≅ 2 x 190 lamps)	
	L 80 W/0.87 A	Units	114 (≅ 2 x 114 lamps)	137 (≅ 2 x 137 lamps)	
Switching gas discharge lamps with correction					
Per main current path at 230 V					
• Shunt compensation with inductive ballast, rated power per lamp/capacitance/rated operational current per lamp					
	L 18 W/4.5 μF/0.11 A	Units	160	197	234
	L 36 W/4.5 μF/0.21 A	Units	160	197	234
	L 58 W/7 μF/0.32 A	Units	103	127	150
	L 80 W/7 μF/0.49 A	Units	103	126	146
• With solid-state ballast ¹⁾ single lamp					
	L 18 W/6.8 μF/0.10 A	Units	455	560	665
	L 36 W/6.8 μF/0.18 A	Units	253	311	369
	L 58 W/10 μF/0.29 A	Units	156	193	229
	L 80 W/10 μF/0.43 A	Units	105	130	154
• With solid-state ballast ¹⁾ two-lamp					
	L 18 W/10 μF/0.18 A	Units	253 (≅ 2 x 253 lamps)	311 (≅ 2 x 311 lamps)	369 (≅ 2 x 369 lamps)
	L 36 W/10 μF/0.35 A	Units	130 (≅ 2 x 130 lamps)	160 (≅ 2 x 160 lamps)	190 (≅ 2 x 190 lamps)
	L 58 W/22 μF/0.52 A	Units	88 (≅ 2 x 88 lamps)	108 (≅ 2 x 108 lamps)	128 (≅ 2 x 128 lamps)
	L 80 W/22 μF/0.86 A	Units	52 (≅ 2 x 52 lamps)	65 (≅ 2 x 65 lamps)	77 (≅ 2 x 77 lamps)
Utilization category AC-5b					
Switching incandescent lamps					
Per main current path at 230/220 V					
		kW	12.3	15.2	18.1

¹⁾ Depending on the electronic ballast used, higher lamp numbers are also possible.

3RT, 3TB, 3TF Contactors for Switching Motors





3RT10 contactors, 3-pole, 3 ... 250 kW

Contactors	Type Size	3RT10 44 S3	3RT10 45 S3	3RT10 46 S3
Main circuit				
AC capacity				
Utilization category AC-6a switching AC transformers				
• Rated operational current I_g (60 °C)				
- For inrush current n = 20	Up to 400 V A	63.5	80	84.4
	Up to 690 V A	47	58	58
- For inrush current n = 30	Up to 400 V A	42.3	56.3	56.3
	Up to 690 V A	42.3	56.3	56.3
• Rating P				
- For inrush current n = 20	230 V kVA	25.3	31.9	33.6
	400 V kVA	43.9	55.4	58
	500 V kVA	54.9	69.3	73.1
	690 V kVA	56.2	69.3	69.3
- For inrush current n = 30	230 V kVA	16.8	22.4	22.4
	400 V kVA	29.3	39	39
	500 V kVA	36.6	48.7	48.7
	690 V kVA	50.3	67.3	67.3
For deviating inrush current factors x, the power must be recalculated as follows. $P_x = P_{n30} \cdot 30/x$				
Utilization category AC-6b Switching low-inductance (low-loss, metallized dielectric) AC capacitors				
• Rated operational current I_g (60 °C)	Up to 400 V A	57	72	
• Rated power for single capacitors or banks of capacitors (minimum inductance of 6 µH between capacitors connected in parallel) at 50 Hz, 60 Hz and	At 230 V kvar	24	29	
	400 V kvar	40	50	
	525 V kvar	50	65	
	690 V kvar	40	50	
Load rating with DC				
Utilization category DC-1 Switching resistive load ($L/R \leq 1$ ms)				
• Rated operational current I_g (60 °C)				
- 1 conducting path	Up to 24 V A	90	100	100
	60 V A	23	60	60
	110 V A	4.5	9	9
	220 V A	1	2	2
	440 V A	0.4	0.6	0.6
	600 V A	0.26	0.4	0.4
- 2 conducting paths in series	Up to 24 V A	90	100	100
	60 V A	90	100	100
	110 V A	90	100	100
	220 V A	5	10	10
	440 V A	1	1.8	1.8
	600 V A	0.8	1	1
- 3 conducting paths in series	Up to 24 V A	90	100	100
	60 V A	90	100	100
	110 V A	90	100	100
	220 V A	70	80	80
	440 V A	2.9	1.8	4.5
	600 V A	1.4	1	2.6
Utilization category DC-3 and DC-5 Shunt-wound and series-wound motors ($L/R \leq 15$ ms)				
• Rated operational current I_g (60 °C)				
- 1 conducting path	Up to 24 V A	40	40	40
	60 V A	6	6.5	6.5
	110 V A	2.5	2.5	2.5
	220 V A	1	1	1
	440 V A	0.15	0.15	0.15
	600 V A	0.06	0.06	0.06
- 2 conducting paths in series	Up to 24 V A	90	100	100
	60 V A	90	100	100
	110 V A	90	100	100
	220 V A	7	7	7
	440 V A	0.42	0.42	0.42
	600 V A	0.16	0.16	0.16
- 3 conducting paths in series	Up to 24 V A	90	100	100
	60 V A	90	100	100
	110 V A	90	100	100
	220 V A	35	35	35
	440 V A	0.8	0.8	0.8
	600 V A	0.35	0.35	0.35

3RT, 3TB, 3TF Contactors for Switching Motors

3RT10 contactors, 3-pole, 3 ... 250 kW

Contactors	Type Size	3RT10 44 S3	3RT10 45 S3	3RT10 46 S3
Main circuit				
Switching frequency				
Switching frequency z in operating cycles/hour				
• Contactors without overload relays	No-load switching frequency AC	h ⁻¹ 5000	5000	5000
	No-load switching frequency DC	h ⁻¹ 1000	1000	1000
Dependence of the switching frequency z' on the operational current I' and operational voltage U':	AC-1 (AC/DC)	h ⁻¹ 1000	900	900
	AC-2 (AC/DC)	h ⁻¹ 400	400	350
	AC-3 (AC/DC)	h ⁻¹ 1000	1000	850
	AC-4 (AC/DC)	h ⁻¹ 300	300	250
• Contactors with overload relays (mean value)		h ⁻¹ 15	15	15

Contactors	Type Size	3RT10 4. S3
Conductor cross-sections (1 or 2 conductors connectable)		
	Main conductors: With box terminal	 Screw terminals
Front clamping point connected	<ul style="list-style-type: none"> • Finely stranded with end sleeve • Finely stranded without end sleeve • Solid • Stranded • Ribbon cable conductors (number x width x thickness) • AWG cables, solid or stranded 	 NSB00479 mm ² 2.5 ... 35 mm ² 4 ... 50 mm ² 2.5 ... 16 mm ² 4 ... 70 mm 6 x 9 x 0.8 AWG 10 ... 2/0
Rear clamping point connected	<ul style="list-style-type: none"> • Finely stranded with end sleeve • Finely stranded without end sleeve • Solid • Stranded • Ribbon cable conductors (number x width x thickness) • AWG cables, solid or stranded 	 NSB00480 mm ² 2.5 ... 50 mm ² 10 ... 50 mm ² 2.5 ... 16 mm ² 10 ... 70 mm 6 x 9 x 0.8 AWG 10 ... 2/0
Both clamping points connected	<ul style="list-style-type: none"> • Finely stranded with end sleeve • Finely stranded without end sleeve • Solid • Stranded • Ribbon cable conductors (number x width x thickness) • AWG cables, solid or stranded • Terminal screw - Tightening torque 	 NSB00481 mm ² 2 x (2.5 ... 35) mm ² 2 x (4 ... 35) mm ² 2 x (2.5 ... 16) mm ² 2 x (4 ... 50) mm 2 x (6 x 9 x 0.8) AWG 2 x (10 ... 1/0) M6 (hexagon socket, A/F 4) Nm 4 ... 6 (36 ... 53 lb.in)
Connection for drilled copper bars ¹⁾	Max. width	mm 10
Without box terminal with cable lugs ²⁾ (1 or 2 conductors can be connected)	<ul style="list-style-type: none"> • Finely stranded with cable lug • Stranded with cable lug • AWG cables, solid or stranded 	mm ² 10 ... 50 ³⁾ mm ² 10 ... 70 ³⁾ AWG 7 ... 1/0
	Auxiliary conductors:	
	<ul style="list-style-type: none"> • Solid • Finely stranded with end sleeve • AWG cables, solid or stranded • Terminal screw - Tightening torque 	mm ² 2 x (0.5 ... 1.5) ⁴⁾ ; 2 x (0.75 ... 2.5) ⁴⁾ acc. to IEC 60947; max. 2 x (0.75 ... 4) mm ² 2 x (0.5 ... 1.5) ⁴⁾ ; 2 x (0.75 ... 2.5) ⁴⁾ AWG 2 x (20 ... 16) ⁴⁾ ; 2 x (18 ... 14) ⁴⁾ ; 1 x 12 M3 Nm 0.8 ... 1.2 (7 ... 10.3 lb.in)
	Auxiliary conductors:	 Cage Clamp terminals
	<ul style="list-style-type: none"> • Solid • Finely stranded with end sleeve • Finely stranded without end sleeve • AWG cables, solid or stranded 	mm ² 2 x (0.25 ... 2.5) mm ² 2 x (0.25 ... 1.5) mm ² 2 x (0.25 ... 2.5) AWG 2 x (24 ... 14)

For tools for opening Cage Clamp terminals see Catalog LV 1, Chapter 3, Accessories and Spare Parts.
 Maximum external diameter of the conductor insulation: 3.6 mm.
 For conductor cross-sections ≤ 1 mm² an "insulation stop" must be used, see Catalog LV 1, Chapter 3, "Accessories and Spare Parts".

- 1) If bars larger than 12 x 10 mm are connected, a 3RT19 46-4EA1 terminal cover is needed to comply with the phase clearance.
- 2) If conductors larger than 25 mm² are connected, a 3RT19 46-4EA1 terminal cover is needed to comply with the phase clearance.
- 3) Only with crimped cable lugs according to DIN 46234. Cable lug max. 20 mm wide.
- 4) If two different conductor cross-sections are connected to one clamping point, both cross-sections must lie in the range specified. If identical cross-sections are used, this restriction does not apply.

3RT, 3TB, 3TF Contactors for Switching Motors

3RT10 contactors, 3-pole, 3 ... 250 kW

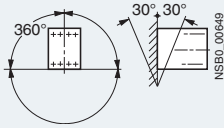
Contactors	Type Size	3RT10 54 S6	3RT10 55 S6	3RT10 56 S6
General data				
Permissible mounting position The contactors are designed for operation on a vertical mounting surface.				
Mechanical endurance	Operating cycles	10 million		
Electrical endurance		1)		
Rated insulation voltage U_i (degree of pollution 3)	V	1000		
Rated impulse withstand voltage U_{imp}	kV	8		
Protective separation between the coil and the main contacts acc. to EN 60947-1, Appendix N	V	690		
Mirror contacts A mirror contact is an auxiliary NC contact that cannot be closed simultaneously with a NO main contact.		Yes, acc. to EN 60947-4-1, Appendix F		
Permissible ambient temperature	<ul style="list-style-type: none"> • During operation • During storage 	°C	-25 ... +60/+55 with AS-Interface	
		°C	-55 ... +80	
Degree of protection acc. to EN 60947-1, Appendix C			IP00/open, coil assembly IP20	
Touch protection acc. to EN 50274			Finger-safe with cover	
Shock resistance	<ul style="list-style-type: none"> • Rectangular pulse • Sine pulse 	g/ms	8.5/5 and 4.2/10	
		g/ms	13.4/5 and 6.5/10	
Conductor cross-sections		2)		
Electromagnetic compatibility (EMC)		3)		
Short-circuit protection				
Main circuit Fuse links, gL/gG LV HRC 3NA, DIAZED 5SB, NEOZED 5SE acc. to IEC 60947-4-1/ EN 60947-4-1			For short-circuit protection for contactors with overload relays see "Protection Equipment --> Overload Relays".	
	<ul style="list-style-type: none"> • Type of coordination "1" • Type of coordination "2" • Weld-free⁴⁾ 	A	355	355
		A	315	315
		A	80	160
Auxiliary circuit	<ul style="list-style-type: none"> • Fuse links gL/gG DIAZED 5SB, NEOZED 5SE (weld-free protection at $I_k \geq 1$ kA) • Or miniature circuit breakers with C characteristic ($I_k < 400$ A) 	A	10	

1) For endurance of the main contacts see page 3/19.

2) For conductor cross-sections see page 3/42.

3) For electromagnetic compatibility (EMC) see page 3/12.

4) Test conditions according to IEC 60947-4-1.

3RT, 3TB, 3TF Contactors for Switching Motors

3RT10 contactors, 3-pole, 3 ... 250 kW

Contactors	Type Size	3RT10 5. S6	
Control			
Operating range of the solenoid AC/DC (UC)		0.8 x $U_{s \min}$... 1.1 x $U_{s \max}$	
Power consumption of the solenoid (when coil is cool and rated range $U_{s \min}$... $U_{s \max}$)			
• Conventional operating mechanism			
- AC operation	Closing at $U_{s \min}$	VA/p.f.	250/0.9
	Closing at $U_{s \max}$	VA/p.f.	300/0.9
	Closed at $U_{s \min}$	VA/p.f.	4.8/0.8
	Closed at $U_{s \max}$	VA/p.f.	5.8/0.8
- DC operation	Closing at $U_{s \min}$	W	300
	Closing at $U_{s \max}$	W	360
	Closed at $U_{s \min}$	W	4.3
	Closed at $U_{s \max}$	W	5.2
• Solid-state operating mechanism			
- AC operation	Closing at $U_{s \min}$	VA/p.f.	190/0.8
	Closing at $U_{s \max}$	VA/p.f.	280/0.8
	Closed at $U_{s \min}$	VA/p.f.	3.5/0.5
	Closed at $U_{s \max}$	VA/p.f.	4.4/0.4
- DC operation	Closing at $U_{s \min}$	W	250
	Closing at $U_{s \max}$	W	320
	Closed at $U_{s \min}$	W	2.3
	Closed at $U_{s \max}$	W	2.8
PLC control input (EN 61131-2/type 2)		24 V DC/≤ 30 mA power consumption, (operating range 17 ... 30 V DC)	
Operating times (Total break time = Opening delay + Arcing time)			
• Conventional operating mechanism			
- With 0.8 x $U_{s \min}$... 1.1 x $U_{s \max}$	Closing delay	ms	20 ... 95
	Opening delay	ms	40 ... 60
- With $U_{s \min}$... $U_{s \max}$	Closing delay	ms	25 ... 50
	Opening delay	ms	40 ... 60
• Solid-state operating mechanism, actuated via PLC input			
- With 0.8 x $U_{s \min}$... 1.1 x $U_{s \max}$	Closing delay	ms	35 ... 75
	Opening delay	ms	80 ... 90
- With $U_{s \min}$... $U_{s \max}$	Closing delay	ms	40 ... 60
	Opening delay	ms	80 ... 90
• Solid-state operating mechanism, actuated via A1/A2			
- With 0.8 x $U_{s \min}$... 1.1 x $U_{s \max}$	Closing delay	ms	95 ... 135
	Opening delay	ms	80 ... 90
- With $U_{s \min}$... $U_{s \max}$	Closing delay	ms	100 ... 120
	Opening delay	ms	80 ... 90
• Arcing time			
		ms	10 ... 15

3RT, 3TB, 3TF Contactors for Switching Motors

3RT10 contactors, 3-pole, 3 ... 250 kW

Contactors	Type Size		3RT10 54 S6	3RT10 55 S6	3RT10 56 S6
Main circuit					
<i>AC capacity</i>					
Utilization category AC-1					
Switching resistive loads					
• Rated operational currents I_e		At 40 °C up to 690 V	A 160	185	215
		At 60 °C up to 690 V	A 140	160	185
		At 60 °C up to 1000 V	A 80	90	100
• Rated power for AC loads ¹⁾ P.f. = 0.95 (at 60 °C)		At 230 V	kW 53	60	70
		400 V	kW 92	105	121
		500 V	kW 115	131	152
		690 V	kW 159	181	210
		1000 V	kW 131	148	165
• Minimum conductor cross-section for loads with I_e		At 40 °C	mm ² 70	95	95
		At 60 °C	mm ² 50	70	95
Utilization category AC-2 and AC-3					
• Rated operational currents I_e		Up to 500 V	A 115	150	185
		690 V	A 115	150	170
		1000 V	A 53	65	65
• Rated power of slipping or squirrel-cage motors at 50 and 60 Hz		At 230 V	kW 37	50	61
		400 V	kW 64	84	104
		500 V	kW 81	105	132
		690 V	kW 113	146	167
		1000 V	kW 75	90	90
Thermal load capacity					
		10 s current ²⁾	A 1100	1300	1480
Power loss per main current path					
		At $I_e/AC-3/500$ V	W 7	9	13
Utilization category AC-4 (for $I_a = 6 \times I_e$)					
• Rated operational current I_e		Up to 400 V	A 97	132	160
• Rated power for squirrel-cage motors with 50 Hz and 60 Hz		At 400 V	kW 55	75	90
• The following applies to a contact endurance of about 200 000 operating cycles:					
- Rated operational currents I_e		Up to 500 V	A 54	68	81
		690 V	A 48	57	65
		1000 V	A 34	38	42
- Rated power for squirrel-cage motors with 50 Hz and 60 Hz		At 230 V	kW 16	20	25
		400 V	kW 29	38	45
		500 V	kW 37	47	57
		690 V	kW 48	55	65
		1000 V	kW 49	55	60
Utilization category AC-6a					
switching AC transformers					
• Rated operational current I_e					
- For inrush current n = 20		Up to 690 V	A 115	148	148
- For inrush current n = 30		Up to 690 V	A 90	99	99
• Rating P					
- For inrush current n = 20		At 230 V	kVA 45	58	58
		400 V	kVA 79	102	102
		500 V	kVA 99	128	128
		690 V	kVA 137	176	176
		1000 V	kVA 80	98	117
- For inrush current n = 30		At 230 V	kVA 35	39	39
		400 V	kVA 62	68	68
		500 V	kVA 77	85	85
		690 V	kVA 107	118	118
		1000 V	kVA 80	98	117
For deviating inrush current factors x, the power must be recalculated as follows: $P_x = P_{n,30} \cdot 30/x$					
Utilization category AC-6b					
Switching low-inductance (low-loss, metallized dielectric) AC capacitors					
Ambient temperature 40 °C					
• Rated operational currents I_e		Up to 500 V	A 105	125	145
• Rated power for single capacitors or banks of capacitors (minimum induc- tance of 6 µH between capacitors con- nected in parallel) at 50 Hz, 60 Hz		At 230 V	kvar 42	50	58
		400 V	kvar 72	86	100
		500 V	kvar 90	108	125
		690 V	kvar 72	86	100

¹⁾ Industrial furnaces and electric heaters with resistance heating, etc.
(increased power consumption on heating up has been taken into
account).

²⁾ According to IEC 60947-4-1.
For rated values for various start-up conditions see
"Protection Equipment --> Overload Relays".









3RT, 3TB, 3TF Contactors for Switching Motors

3RT10 contactors, 3-pole, 3 ... 250 kW

Contactors	Type Size	3RT10 54 S6	3RT10 55 S6	3RT10 56 S6
Main circuit				
<i>Load rating with DC</i>				
Utilization category DC-1				
Switching resistive load ($L/R \leq 1$ ms)				
• Rated operational current I_e (at 60 °C)				
- 1 conducting path		Up to 24 V A	160	
		60 V A	160	
		110 V A	18	
		220 V A	3.4	
		440 V A	0.8	
		600 V A	0.5	
- 2 conducting paths in series		Up to 24 V A	160	
		60 V A	160	
		110 V A	160	
		220 V A	20	
		440 V A	3.2	
		600 V A	1.6	
- 3 conducting paths in series		Up to 24 V A	160	
		60 V A	160	
		110 V A	160	
		220 V A	160	
		440 V A	11.5	
		600 V A	4	
Utilization category DC-3 and DC-5				
Shunt-wound and series-wound motors ($L/R \leq 15$ ms)				
• Rated operational current I_e (at 60 °C)				
- 1 conducting path		Up to 24 V A	160	
		60 V A	7.5	
		110 V A	2.5	
		220 V A	0.6	
		440 V A	0.17	
		600 V A	0.12	
- 2 conducting paths in series		Up to 24 V A	160	
		60 V A	160	
		110 V A	160	
		220 V A	2.5	
		440 V A	0.65	
		600 V A	0.37	
- 3 conducting paths in series		Up to 24 V A	160	
		60 V A	160	
		110 V A	160	
		220 V A	160	
		440 V A	1.4	
		600 V A	0.75	
Switching frequency				
Switching frequency z in operating cycles/hour				
• Contactors without overload relays	No-load switching frequency	h ⁻¹	2000	2000
Dependence of the switching frequency z' on the operational current I' and operational voltage U' :				
$z' = z \cdot (I_e/I') \cdot (400 V/U')^{1.5} \cdot 1/h$				
	AC-1	h ⁻¹	800	800
	AC-2	h ⁻¹	400	300
	AC-3	h ⁻¹	1000	750
	AC-4	h ⁻¹	130	130
• Contactors with overload relays (mean value)		h ⁻¹	60	60

3RT, 3TB, 3TF Contactors for Switching Motors

3RT10 contactors, 3-pole, 3 ... 250 kW

Contactors	Type Size	3RT10 5. S6	
Conductor cross-sections of main conductors with box terminal			
(1 or 2 conductors can be connected)	Main conductors: With 3RT19 55-4G box terminal (55 kW)		 Screw terminals
Front or rear clamping point connected	<ul style="list-style-type: none"> Finely stranded with end sleeve Finely stranded without end sleeve Stranded Ribbon cable conductors (number x width x thickness) AWG cables, solid or stranded 	mm ² mm ² mm ² mm AWG	16 ... 70 16 ... 70 16 ... 70 Min. 3 x 9 x 0.8, max. 6 x 15.5 x 0.8 6 ... 2/0
 			
Both clamping points connected	<ul style="list-style-type: none"> Finely stranded with end sleeve Finely stranded without end sleeve Stranded Ribbon cable conductors (number x width x thickness) AWG cables, solid or stranded Terminal screw - Tightening torque 	mm ² mm ² mm ² mm AWG Nm	Max. 1 x 50, 1 x 70 Max. 1 x 50, 1 x 70 max. 2 x 70 Max. 2 x (6 x 15.5 x 0.8) Max. 2 x 1/0 M10 (hexagon socket, A/F 4) 10 ... 12 (90 ... 110 lb.in)
			
(1 or 2 conductors can be connected)	Main conductors: With 3RT19 56-4G box terminal		
Front or rear clamping point connected	<ul style="list-style-type: none"> Finely stranded with end sleeve Finely stranded without end sleeve Stranded Ribbon cable conductors (number x width x thickness) AWG cables, solid or stranded 	mm ² mm ² mm ² mm AWG	16 ... 120 16 ... 120 16 ... 120 Min. 3 x 9 x 0.8, max. 10 x 15.5 x 0.8 6 ... 250 kcmil
 			
Both clamping points connected	<ul style="list-style-type: none"> Finely stranded with end sleeve Finely stranded without end sleeve Stranded Ribbon cable conductors (number x width x thickness) AWG cables, solid or stranded Terminal screw - Tightening torque 	mm ² mm ² mm ² mm AWG Nm	Max. 1 x 95, 1 x 120 Max. 1 x 95, 1 x 120 Max. 2 x 120 Max. 2 x (10 x 15.5 x 0.8) Max. 2 x 3/0 M10 (hexagon socket, A/F 4) 10 ... 12 (90 ... 110 lb.in)
			
	Main conductors: Without box terminal/busbar connection		
	<ul style="list-style-type: none"> Finely stranded with cable lug¹⁾ Stranded with cable lug¹⁾ AWG cables, solid or stranded Connecting bar (max. width) Terminal screw - Tightening torque 	mm ² mm ² AWG mm Nm	16 ... 95 25 ... 120 4 ... 250 kcmil 17 M8 x 25 (A/F 13) 10 ... 14 (89 ... 124 lb.in)
	Auxiliary conductors:		
	<ul style="list-style-type: none"> Solid Finely stranded with end sleeve AWG cables, solid or stranded Terminal screw - Tightening torque 	mm ² mm ² AWG Nm	2 x (0.5 ... 1.5) ²⁾ ; 2 x (0.75 ... 2.5) ²⁾ acc. to IEC 60947; max. 2 x (0.75 ... 4) 2 x (0.5 ... 1.5) ²⁾ ; 2 x (0.75 ... 2.5) ²⁾ 2 x (18 ... 14) M3 (PZ 2) 0.8 ... 1.2 (7 ... 10.3 lb.in)
	Auxiliary conductors:		 Cage Clamp terminals
	<ul style="list-style-type: none"> Solid Finely stranded with end sleeve Finely stranded without end sleeve AWG cables, solid or stranded 	mm ² mm ² mm ² AWG	2 x (0.25 ... 2.5) 2 x (0.25 ... 1.5) 2 x (0.25 ... 2.5) 2 x (24 ... 14)

For tools for opening Cage Clamp terminals see Catalog LV 1, Chapter 3, Accessories and Spare Parts.
Maximum external diameter of the conductor insulation: 3.6 mm.
For conductor cross-sections $\leq 1 \text{ mm}^2$ an "insulation stop" must be used, see Catalog LV 1, Chapter 3, "Accessories and Spare Parts".

- When connecting cable lugs to DIN 46235, use 3RT19 56-4EA1 terminal cover for conductor cross-sections from 95 mm² to ensure phase spacing.
- If two different conductor cross-sections are connected to one clamping point, both cross-sections must lie in the range specified. If identical cross-sections are used, this restriction does not apply.

3RT, 3TB, 3TF Contactors for Switching Motors

3RT10 contactors, 3-pole, 3 ... 250 kW

Contactors	Type Size	3RT10 64 S10	3RT10 65 S10	3RT10 66 S10
General data				
Permissible mounting position The contactors are designed for operation on a vertical mounting surface.				
Mechanical endurance	Oper- ating cycles	10 million		
Electrical endurance		1)		
Rated insulation voltage U_i (degree of pollution 3)	V	1000		
Rated impulse withstand voltage U_{imp}	kV	8		
Protective separation between the coil and the main contacts acc. to EN 60947-1, Appendix N	V	690		
Mirror contacts A mirror contact is an auxiliary NC contact that cannot be closed simultaneously with a NO main contact.		Yes, acc. to EN 60947-4-1, Appendix F		
Permissible ambient temperature	<ul style="list-style-type: none"> • During operation • During storage 	°C	-25 ... +60/+55 with AS-Interface	
Degree of protection acc. to EN 60947-1, Appendix C		°C	-55 ... +80	
Touch protection acc. to EN 50274			IP00/open, coil assembly IP20 Finger-safe with cover	
Shock resistance	<ul style="list-style-type: none"> • Rectangular pulse • Sine pulse 	g/ms g/ms	8.5/5 and 4.2/10 13.4/5 and 6.5/10	
Conductor cross-sections			2)	
Electromagnetic compatibility (EMC)			3)	
Short-circuit protection				
Main circuit				
Fuse links, gL/gG				
LV HRC 3NA, DIAZED 5SB, NEOZED 5SE				
acc. to IEC 60947-4-1/ EN 60947-4-1				
	<ul style="list-style-type: none"> • Type of coordination "1" • Type of coordination "2" • Weld-free⁴⁾ 	A	500	
		A	400	
		A	250	
Auxiliary circuit				
	<ul style="list-style-type: none"> • Fuse links gL/gG DIAZED 5SB, NEOZED 5SE (weld-free protection at $I_k \geq 1$ kA) • Or miniature circuit breakers with C characteristic (short-circuit current $I_k < 400$ A) 	A	10	

¹⁾ For endurance of the main contacts see page 3/19.

²⁾ For conductor cross-sections see page 3/47.

³⁾ For electromagnetic compatibility (EMC) see page 3/12.

⁴⁾ Test conditions according to IEC 60947-4-1.

3RT, 3TB, 3TF Contactors for Switching Motors

3RT10 contactors, 3-pole, 3 ... 250 kW

Contactor	Type Size		3RT10 64 S10	3RT10 65 S10	3RT10 66 S10
Control					
Operating range of the solenoid AC/DC (UC)			$0.8 \times U_{s \min} \dots 1.1 \times U_{s \max}$		
Power consumption of the solenoid (when coil is cool and rated range $U_{s \min} \dots U_{s \max}$)					
• Conventional operating mechanism					
- AC operation	Closing at $U_{s \min}$	VA/p.f.	490/0.9		
	Closing at $U_{s \max}$	VA/p.f.	590/0.9		
	Closed at $U_{s \min}$	VA/p.f.	5.6/0.9		
	Closed at $U_{s \max}$	VA/p.f.	6.7/0.9		
- DC operation	Closing at $U_{s \min}$	W	540		
	Closing at $U_{s \max}$	W	650		
	Closed at $U_{s \min}$	W	6.1		
	Closed at $U_{s \max}$	W	7.4		
• Solid-state operating mechanism					
- AC operation	Closing at $U_{s \min}$	VA/p.f.	400/0.8		
	Closing at $U_{s \max}$	VA/p.f.	530/0.8		
	Closed at $U_{s \min}$	VA/p.f.	4/0.5		
	Closed at $U_{s \max}$	VA/p.f.	5/0.4		
- DC operation	Closing at $U_{s \min}$	W	440		
	Closing at $U_{s \max}$	W	580		
	Closed at $U_{s \min}$	W	3.2		
	Closed at $U_{s \max}$	W	3.8		
PLC control input (EN 61131-2/type 2)			24 V DC/≤ 30 mA power consumption, (operating range 17 ... 30 V DC)		
Operating times (Total break time = Opening delay + Arcing time)					
• Conventional operating mechanism					
- With $0.8 \times U_{s \min} \dots 1.1 \times U_{s \max}$	Closing delay	ms	30 ... 95		
	Opening delay	ms	40 ... 80		
- For $U_{s \min} \dots U_{s \max}$	Closing delay	ms	35 ... 50		
	Opening delay	ms	50 ... 80		
• Solid-state operating mechanism, actuated via A1/A2					
- With $0.8 \times U_{s \min} \dots 1.1 \times U_{s \max}$	Closing delay	ms	105 ... 145		
	Opening delay	ms	80 ... 100		
- For $U_{s \min} \dots U_{s \max}$	Closing delay	ms	110 ... 130		
	Opening delay	ms	80 ... 100		
• Solid-state operating mechanism, actuated via PLC input					
- With $0.8 \times U_{s \min} \dots 1.1 \times U_{s \max}$	Closing delay	ms	45 ... 80		
	Opening delay	ms	80 ... 100		
- For $U_{s \min} \dots U_{s \max}$	Closing delay	ms	50 ... 65		
	Opening delay	ms	80 ... 100		
• Arcing time					
		ms	10 ... 15		

3RT, 3TB, 3TF Contactors for Switching Motors

3RT10 contactors, 3-pole, 3 ... 250 kW

Contactors	Type Size		3RT10 64 S10	3RT10 65 S10	3RT10 66 S10
Main circuit					
AC capacity					
Utilization category AC-1					
Switching resistive loads					
• Rated operational currents I_e	At 40 °C up to 690 V	A	275	330	
	At 60 °C up to 690 V	A	250	300	
	At 60 °C up to 1000 V	A	100	150	
• Rated power for AC loads ¹⁾ P.f. = 0.95 (at 60 °C)	At 230 V	kW	94	113	
	400 V	kW	164	197	
	500 V	kW	205	246	
	690 V	kW	283	340	
	1000 V	kW	164	246	
• Minimum conductor cross-section for loads with I_e	At 40 °C	mm ²	150	185	
	At 60 °C	mm ²	120	185	
Utilization category AC-2 and AC-3					
• Rated operational currents I_e	Up to 500 V	A	225	265	300
	690 V	A	225	265	280
	1000 V	A	68	95	95
• Rated power of slipping or squirrel-cage motors at 50 and 60 Hz	At 230 V	kW	73	85	97
	400 V	kW	128	151	171
	500 V	kW	160	189	215
	690 V	kW	223	265	280
	1000 V	kW	90	132	132
Thermal load capacity	10 s current ²⁾	A	1800	2400	2400
Power loss per main current path	At I_e /AC-3/500 V	W	17	18	22
Utilization category AC-4 (for $I_a = 6 \times I_e$)					
• Rated operational current I_e	Up to 400 V	A	195	230	280
• Rated power for squirrel-cage motors with 50 Hz and 60 Hz	At 400 V	kW	110	132	160
• The following applies to a contact endurance of about 200 000 operating cycles:					
- Rated operational currents I_e	Up to 500 V	A	96	117	125
	690 V	A	85	105	115
	1000 V	A	42	57	57
- Rated power for squirrel-cage motors with 50 Hz and 60 Hz	At 230 V	kW	30	37	40
	400 V	kW	54	66	71
	500 V	kW	67	82	87
	690 V	kW	82	102	112
	1000 V	kW	59	80	80
Utilization category AC-6a switching AC transformers					
• Rated operational current I_e					
- For inrush current n = 20	Up to 690 V	A	227	265	273
- For inrush current n = 30	Up to 690 V	A	151	182	182
• Rated power P					
- For inrush current n = 20	At 230 V	kVA	90	105	109
	400 V	kVA	157	183	189
	500 V	kVA	196	229	236
	690 V	kVA	271	317	326
	1000 V	kVA	117	164	164
- For inrush current n = 30	At 230 V	kVA	60	72	72
	400 V	kVA	105	126	126
	500 V	kVA	130	158	158
	690 V	kVA	180	217	217
	1000 V	kVA	117	164	164
For deviating inrush current factors x, the power must be recalculated as follows: $P_x = P_{n30} \cdot 30/x$					
Utilization category AC-6b Switching low-inductance (low-loss, metallized dielectric) AC capacitors					
Ambient temperature 40 °C					
• Rated operational currents I_e	Up to 500 V	A	183	220	
• Rated power for single capacitors or banks of capacitors (minimum inductance of 6 µH between capacitors connected in parallel) at 50 Hz, 60 Hz and	At 230 V	kvar	73	88	
	400 V	kvar	127	152	
	500 V	kvar	159	191	
	690 V	kvar	127	152	

¹⁾ Industrial furnaces and electric heaters with resistance heating, etc. (increased power consumption on heating up has been taken into account).

²⁾ According to IEC 60947-4-1.
For rated values for various start-up conditions see "Protection Equipment --> Overload Relays".





3RT, 3TB, 3TF Contactors for Switching Motors

3RT10 contactors, 3-pole, 3 ... 250 kW

Contactor	Type Size		3RT10 64 S10	3RT10 65 S10	3RT10 66 S10
Main circuit					
<i>Load rating with DC</i>					
Utilization category DC-1					
Switching resistive load ($L/R \leq 1$ ms)					
• Rated operational current I_e (at 60 °C)					
- 1 conducting path		Up to 24 V A	200	300	
		60 V A	200	300	
		110 V A	18	33	
		220 V A	3.4	3.8	
		440 V A	0.8	0.9	
		600 V A	0.5	0.6	
- 2 conducting paths in series		Up to 24 V A	200	300	
		60 V A	200	300	
		110 V A	200	300	
		220 V A	20	300	
		440 V A	3.2	4	
		600 V A	1.6	2	
- 3 conducting paths in series		Up to 24 V A	200	300	
		60 V A	200	300	
		110 V A	200	300	
		220 V A	200	300	
		440 V A	11.5	11	
		600 V A	4	5.2	
Utilization category DC-3 and DC-5					
Shunt-wound and series-wound motors ($L/R \leq 15$ ms)					
• Rated operational current I_e (at 60 °C)					
- 1 conducting path		Up to 24 V A	200	300	
		60 V A	7.5	11	
		110 V A	2.5	3	
		220 V A	0.6	0.6	
		440 V A	0.17	0.18	
		600 V A	0.12	0.125	
- 2 conducting paths in series		Up to 24 V A	200	300	
		60 V A	200	300	
		110 V A	200	300	
		220 V A	2.5	2.5	
		440 V A	0.65	0.65	
		600 V A	0.37	0.37	
- 3 conducting paths in series		Up to 24 V A	200	300	
		60 V A	200	300	
		110 V A	200	300	
		220 V A	200	300	
		440 V A	1.4	1.4	
		600 V A	0.75	0.75	
Switching frequency					
Switching frequency z in operating cycles/hour					
• Contactors without overload relays	No-load switching frequency	h ⁻¹	2000	2000	2000
Dependence of the switching frequency z' on the operational current I' and operational voltage U':	AC-1	h ⁻¹	750	800	750
$z' = z \cdot (I_e/I') \cdot (400 V/U')^{1.5} \cdot 1/h$	AC-2	h ⁻¹	250	300	250
	AC-3	h ⁻¹	500	700	500
	AC-4	h ⁻¹	130	130	130
• Contactors with overload relays (mean value)		h ⁻¹	60	60	60

3RT, 3TB, 3TF Contactors for Switching Motors

3RT10 contactors, 3-pole, 3 ... 250 kW

Contactors	Type Size	3RT10 6. S10		
Conductor cross-sections				
Front clamping point connected 	Main conductors: With 3RT19 66-4G box terminal		 Screw terminals	
	<ul style="list-style-type: none"> Finely stranded with end sleeve Finely stranded without end sleeve Stranded AWG cables, solid or stranded Ribbon cable conductors (number x width x thickness) 	mm ² mm ² mm ² AWG mm		70 ... 240 70 ... 240 95 ... 300 3/0 ... 600 kcmil Min. 6 x 9 x 0.8, max. 20 x 24 x 0.5
	Rear clamping point connected 	<ul style="list-style-type: none"> Finely stranded with end sleeve Finely stranded without end sleeve Stranded AWG cables, solid or stranded Ribbon cable conductors (number x width x thickness) 		mm ² mm ² mm ² AWG mm
Both clamping points connected 	<ul style="list-style-type: none"> Finely stranded with end sleeve Finely stranded without end sleeve Stranded AWG cables, solid or stranded Ribbon cable conductors (number x width x thickness) Terminal screws - Tightening torque 	mm ² mm ² mm ² AWG mm Nm	Min. 2 x 50, max. 2 x 185 Min. 2 x 50, max. 2 x 185 Min. 2 x 70, max. 2 x 240 Min. 2 x 2/0, max. 2 x 500 kcmil Max. 2 x (20 x 24 x 0.5) M12 (hexagon socket, A/F 5) 20 ... 22 (180 ... 195 lb.in)	
		Main conductors: Without box terminal/ busbar connection		
		<ul style="list-style-type: none"> Finely stranded with cable lug¹⁾ Stranded with cable lug¹⁾ AWG cables, solid or stranded Connecting bar (max. width) Terminal screws - Tightening torque 	mm ² mm ² AWG mm Nm	50 ... 240 70 ... 240 2/0 ... 500 kcmil 25 M10 x 30 (A/F 17) 14 ... 24 (124 ... 210 lb.in)
		Auxiliary conductors:		
		<ul style="list-style-type: none"> Solid Finely stranded with end sleeve AWG cables, solid or stranded Terminal screws - Tightening torque 	mm ² mm ² AWG Nm	2 x (0.5 ... 1.5) ²⁾ ; 2 x (0.75 ... 2.5) ²⁾ acc. to IEC 60947; max. 2 x (0.75 ... 4) 2 x (0.5 ... 1.5) ²⁾ ; 2 x (0.75 ... 2.5) ²⁾ 2 x (18 ... 14) M3 (PZ 2) 0.8 ... 1.2 (7 ... 10.3 lb.in)
		Auxiliary conductors:		
		<ul style="list-style-type: none"> Solid Finely stranded with end sleeve Finely stranded without end sleeve AWG cables, solid or stranded 	mm ² mm ² mm ² AWG	 Cage Clamp terminals 2 x (0.25 ... 2.5) 2 x (0.25 ... 1.5) 2 x (0.25 ... 2.5) 2 x (24 ... 14)

For tools for opening Cage Clamp terminals see Catalog LV 1, Chapter 3, Accessories and Spare Parts.

Maximum external diameter of the conductor insulation: 3.6 mm. For conductor cross-sections $\leq 1 \text{ mm}^2$ an "insulation stop" must be used, see Catalog LV 1, Chapter 3, "Accessories and Spare Parts".

¹⁾ When connecting cable lugs to DIN 46234, the 3RT19 66-4EA1 terminal cover must be used for conductor cross-sections of 240 mm² and more as well as DIN 46235 for conductor cross-sections of 185 mm² and more to keep the phase clearance.

²⁾ If two different conductor cross-sections are connected to one clamping point, both cross-sections must lie in the range specified. If identical cross-sections are used, this restriction does not apply.

3RT, 3TB, 3TF Contactors for Switching Motors

3RT10 contactors, 3-pole, 3 ... 250 kW

Contactor	Type Size	3RT10 75 S12		3RT10 76 S12	
General data					
Permissible mounting position The contactors are designed for operation on a vertical mounting surface.					
Mechanical endurance	Operating cycles	10 million			
Electrical endurance		1)			
Rated insulation voltage U_i (degree of pollution 3)	V	1000			
Rated impulse withstand voltage U_{imp}	kV	8			
Protective separation between the coil and the main contacts acc. to EN 60947-1, Appendix N	V	690			
Mirror contacts A mirror contact is an auxiliary NC contact that cannot be closed simultaneously with a NO main contact.		Yes, acc. to EN 60947-4-1, Appendix F			
Permissible ambient temperature	<ul style="list-style-type: none"> During operation During storage 	°C	-25 ... +60/+55 with AS-Interface		
		°C	-55 ... +80		
Degree of protection acc. to EN 60947-1, Appendix C		IP00/open, coil assembly IP20			
Touch protection acc. to EN 50274		Finger-safe with cover			
Shock resistance	<ul style="list-style-type: none"> Rectangular pulse Sine pulse 	g/ms	8.5/5 and 4.2/10		
		g/ms	13.4/5 and 6.5/10		
Conductor cross-sections		2)			
Electromagnetic compatibility (EMC)		3)			
Short-circuit protection					
Main circuit					
Fuse links, gL/gG					
LV HRC 3NA, DIAZED 5SB, NEOZED 5SE					
acc. to IEC 60947-4-1/ EN 60947-4-1					
	<ul style="list-style-type: none"> Type of coordination "1" Type of coordination "2" Weld-free⁴⁾ 	A	630	630	
		A	500	500	
		A	250	315	
Auxiliary circuit					
<ul style="list-style-type: none"> Fuse links gL/gG DIAZED 5SB, NEOZED 5SE (weld-free protection for $I_k \geq 1$ kA) Or miniature circuit breakers with C characteristic (short-circuit current $I_k < 400$ A) 		A	10		

1) For endurance of the main contacts see page 3/19.

2) For conductor cross-sections see page 3/52.

3) For electromagnetic compatibility (EMC) see page 3/12.

4) Test conditions according to IEC 60947-4-1.

3RT, 3TB, 3TF Contactors for Switching Motors

3RT10 contactors, 3-pole, 3 ... 250 kW

Contactors	Type Size		3RT10 75 S12	3RT10 76 S12
Control				
Operating range of the solenoid AC/DC (UC)			0.8 x $U_{s \text{ min}}$... 1.1 x $U_{s \text{ max}}$	
Power consumption of the solenoid (when coil is cool and rated range $U_{s \text{ min}}$... $U_{s \text{ max}}$)				
• Conventional operating mechanism				
- AC operation	Closing at $U_{s \text{ min}}$	VA/p.f.	700/0.9	
	Closing at $U_{s \text{ max}}$	VA/p.f.	830/0.9	
	Closed at $U_{s \text{ min}}$	VA/p.f.	7.6/0.9	
	Closed at $U_{s \text{ max}}$	VA/p.f.	9.2/0.9	
- DC operation	Closing at $U_{s \text{ min}}$	W	770	
	Closing at $U_{s \text{ max}}$	W	920	
	Closed at $U_{s \text{ min}}$	W	8.5	
	Closed at $U_{s \text{ max}}$	W	10	
• Solid-state operating mechanism				
- AC operation	Closing at $U_{s \text{ min}}$	VA/p.f.	560/0.8	
	Closing at $U_{s \text{ max}}$	VA/p.f.	750/0.8	
	Closed at $U_{s \text{ min}}$	VA/p.f.	5.4/0.8	
	Closed at $U_{s \text{ max}}$	VA/p.f.	7/0.8	
- DC operation	Closing at $U_{s \text{ min}}$	W	600	
	Closing at $U_{s \text{ max}}$	W	800	
	Closed at $U_{s \text{ min}}$	W	4	
	Closed at $U_{s \text{ max}}$	W	5	
PLC control input (EN 61131-2/type 2)			24 V DC/≤ 30 mA power consumption, (operating range 17 ... 30 V DC)	
Operating times (Total break time = Opening delay + Arcing time)				
• Conventional operating mechanism				
- With 0.8 x $U_{s \text{ min}}$... 1.1 x $U_{s \text{ max}}$	Closing delay	ms	45 ... 100	
	Opening delay	ms	60 ... 100	
- For $U_{s \text{ min}}$... $U_{s \text{ max}}$	Closing delay	ms	50 ... 70	
	Opening delay	ms	70 ... 100	
• Solid-state operating mechanism, actuated via A1/A2				
- With 0.8 x $U_{s \text{ min}}$... 1.1 x $U_{s \text{ max}}$	Closing delay	ms	120 ... 150	
	Opening delay	ms	80 ... 100	
- For $U_{s \text{ min}}$... $U_{s \text{ max}}$	Closing delay	ms	125 ... 150	
	Opening delay	ms	80 ... 100	
• Solid-state operating mechanism, actuated via PLC input				
- With 0.8 x $U_{s \text{ min}}$... 1.1 x $U_{s \text{ max}}$	Closing delay	ms	60 ... 90	
	Opening delay	ms	80 ... 100	
- For $U_{s \text{ min}}$... $U_{s \text{ max}}$	Closing delay	ms	65 ... 80	
	Opening delay	ms	80 ... 100	
• Arcing time				
		ms	10 ... 15	

3RT, 3TB, 3TF Contactors for Switching Motors

3RT10 contactors, 3-pole, 3 ... 250 kW

Contactors	Type Size		3RT10 75 S12	3RT10 76 S12
Main circuit				
<i>AC capacity</i>				
Utilization category AC-1				
Switching resistive loads				
• Rated operational currents I_e		At 40 °C up to 690 V	A 430	610
		At 60 °C up to 690 V	A 400	550
		At 60 °C up to 1000 V	A 200	200
• Rated power for AC loads ¹⁾ P.f. = 0.95 (at 60 °C)		At 230 V	kW 151	208
		400 V	kW 263	362
		500 V	kW 329	452
		690 V	kW 454	624
		1000 V	kW 329	329
• Minimum conductor cross-section for loads with I_e		At 40 °C	mm ² 2 x 150	2 x 185
		At 60 °C	mm ² 240	2 x 185
Utilization category AC-2 and AC-3				
• Rated operational currents I_e		Up to 500 V	A 400	500
		690 V	A 400	450
		1000 V	A 180	180
• Rated power of slipping or squirrel-cage motors at 50 and 60 Hz		At 230 V	kW 132	164
		400 V	kW 231	291
		500 V	kW 291	363
		690 V	kW 400	453
		1000 V	kW 250	250
Thermal load capacity		10 s current ²⁾	A 3200	4000
Power loss per main current path		At $I_e/AC-3/500$ V	W 35	55
Utilization category AC-4 (for $I_a = 6 \times I_e$)				
• Rated operational current I_e		Up to 400 V	A 350	430
• Rated power for squirrel-cage motors with 50 Hz and 60 Hz		At 400 V	kW 200	250
• The following applies to a contact endurance of about 200 000 operating cycles:				
- Rated operational current I_e		Up to 500 V	A 150	175
		690 V	A 135	150
		1000 V	A 80	80
- Rated power for squirrel-cage motors with 50 Hz and 60 Hz		At 230 V	kW 48	56
		400 V	kW 85	98
		500 V	kW 105	123
		690 V	kW 133	148
		1000 V	kW 113	113
Utilization category AC-6a switching AC transformers				
• Rated operational current I_e				
- For inrush current n = 20		Up to 690 V	A 377	404
- For inrush current n = 30		Up to 690 V	A 251	270
• Rating P				
- For inrush current n = 20		At 230 V	kVA 150	161
		400 V	kVA 261	280
		500 V	kVA 326	350
		690 V	kVA 450	483
		1000 V	kVA 311	311
- For inrush current n = 30		At 230 V	kVA 100	107
		400 V	kVA 173	187
		500 V	kVA 217	234
		690 V	kVA 300	323
		1000 V	kVA 311	311
For deviating inrush current factors x, the power must be recalculated as follows: $P_x = P_{n30} \cdot 30/x$				
Utilization category AC-6b switching low-inductance (low-loss, metallized dielectric) AC capacitors				
Ambient temperature 40 °C				
• Rated operational currents I_e		Up to 500 V	A 287	407
• Rated power for single capacitors or banks of capacitors (minimum inductance of 6 µH between capacitors connected in parallel) at 50 Hz, 60 Hz and		At 230 V	kvar 114	162
		400 V	kvar 199	282
		500 V	kvar 248	352
		690 V	kvar 199	282

1) Industrial furnaces and electric heaters with resistance heating, etc. (increased power consumption on heating up taken into account).

2) According to IEC 60947-4-1.

For rated values for various start-up conditions see "Protection Equipment --> Overload Relays".





3RT, 3TB, 3TF Contactors for Switching Motors

3RT10 contactors, 3-pole, 3 ... 250 kW

Contactors	Type Size	3RT10 75 S12	3RT10 76 S12
Main circuit			
<i>Load rating with DC</i>			
Utilization category DC-1			
Switching resistive load ($L/R \leq 1$ ms)			
• Rated operational current I_e (at 60 °C)			
- 1 conducting path		Up to 24 V A 400 60 V A 330 110 V A 33 220 V A 3.8 440 V A 0.9 600 V A 0.6	
- 2 conducting paths in series		Up to 24 V A 400 60 V A 400 110 V A 400 220 V A 400 440 V A 4 600 V A 2	
- 3 conducting paths in series		Up to 24 V A 400 60 V A 400 110 V A 400 220 V A 400 440 V A 11 600 V A 5.2	
Utilization category DC-3 and DC-5			
Shunt-wound and series-wound motors ($L/R \leq 15$ ms)			
• Rated operational current I_e (at 60 °C)			
- 1 conducting path		Up to 24 V A 400 60 V A 11 110 V A 3 220 V A 0.6 440 V A 0.18 600 V A 0.125	
- 2 conducting paths in series		Up to 24 V A 400 60 V A 400 110 V A 400 220 V A 2.5 440 V A 0.65 600 V A 0.37	
- 3 conducting paths in series		Up to 24 V A 400 60 V A 400 110 V A 400 220 V A 400 440 V A 1.4 600 V A 0.75	
Switching frequency			
Switching frequency z in operating cycles/hour			
• Contactors without overload relays	No-load switching frequency	h^{-1} 2000	2000
Dependence of the switching frequency z' on the operational current I' and operational voltage U' :		AC-1 h^{-1} 700	500
$z' = z \cdot (I_e/I') \cdot (400 V/U')^{1.5} \cdot 1/h$		AC-2 h^{-1} 200	170
		AC-3 h^{-1} 500	420
		AC-4 h^{-1} 130	130
• Contactors with overload relays (mean value)		h^{-1} 60	60

3RT, 3TB, 3TF Contactors for Switching Motors

3RT10 contactors, 3-pole, 3 ... 250 kW

Contactors	Type Size	3RT10 7. S12	
Conductor cross-sections			
Front clamping point connected 	Main conductors: With 3RT19 66-4G box terminal		 Screw terminals
	<ul style="list-style-type: none"> Finely stranded with end sleeve Finely stranded without end sleeve Stranded AWG cables, solid or stranded Ribbon cable conductors (number x width x thickness) 	mm ² 70 ... 240 mm ² 70 ... 240 mm ² 95 ... 300 AWG 3/0 ... 600 kcmil mm ² Min. 6 x 9 x 0.8, max. 20 x 24 x 0.5	
	Rear clamping point connected 	<ul style="list-style-type: none"> Finely stranded with end sleeve Finely stranded without end sleeve Stranded AWG cables, solid or stranded Ribbon cable conductors (number x width x thickness) 	
Both clamping points connected 	<ul style="list-style-type: none"> Finely stranded with end sleeve Finely stranded without end sleeve Stranded AWG cables, solid or stranded Ribbon cable conductors (number x width x thickness) Terminal screws - Tightening torque 	mm ² Min. 2 x 50, max. 2 x 185 mm ² Min. 2 x 50, max. 2 x 185 mm ² Min. 2 x 70, max. 2 x 240 AWG Min. 2 x 2/0, max. 2 x 500 kcmil mm ² Max. 2 x (20 x 24 x 0.5) Nm M12 (hexagon socket, A/F 5) 20 ... 22 (180 ... 195 lb.in)	
Main conductors: Without box terminal/ busbar connection		<ul style="list-style-type: none"> Finely stranded with cable lug¹⁾ Stranded with cable lug¹⁾ AWG cables, solid or stranded Connecting bar (max. width) Terminal screws - Tightening torque 	mm ² 50 ... 240 mm ² 70 ... 240 AWG 2/0 ... 500 kcmil mm 25 Nm M10 x 30 (A/F 17) 14 ... 24 (124 ... 210 lb.in)
Auxiliary conductors:		<ul style="list-style-type: none"> Solid Finely stranded with end sleeve AWG cables, solid or stranded Terminal screws - Tightening torque 	mm ² 2 x (0.5 ... 1.5) ²⁾ ; 2 x (0.75 ... 2.5) ²⁾ acc. to IEC 60947; max. 2 x (0.75 ... 4) mm ² 2 x (0.5 ... 1.5) ²⁾ ; 2 x (0.75 ... 2.5) ²⁾ AWG 2 x (18 ... 14) Nm M3 (PZ 2) 0.8 ... 1.2 (7 ... 10.3 lb.in)
Auxiliary conductors:		<ul style="list-style-type: none"> Solid Finely stranded with end sleeve Finely stranded without end sleeve AWG cables, solid or stranded 	 Cage Clamp terminals mm ² 2 x (0.25 ... 2.5) mm ² 2 x (0.25 ... 1.5) mm ² 2 x (0.25 ... 2.5) mm ² 2 x (24 ... 14)

For tools for opening Cage Clamp terminals see Catalog LV 1, Chapter 3, Accessories and Spare Parts.

Maximum external diameter of the conductor insulation: 3.6 mm.
 For conductor cross-sections $\leq 1 \text{ mm}^2$ an "insulation stop" must be used, see Catalog LV 1, Chapter 3, "Accessories and Spare Parts".

¹⁾ When connecting cable lugs according to DIN 46234 for conductor cross-sections of 185 mm² and more and according to DIN 46235 for conductor cross-sections of 240 mm² and more, the 3RT19 66-4EA1 terminal cover must be used more to keep the phase clearance.

²⁾ If two different conductor cross-sections are connected to one clamping point, both cross-sections must lie in the range specified. If identical cross-sections are used, this restriction does not apply.

3RT, 3TB, 3TF Contactors for Switching Motors

3RT10 contactors, 3-pole, 3 ... 250 kW

Contactors	Type Size		3RT10 15 S00	3RT10 16 S00	3RT10 17 S00	3RT10 23 S0	3RT10 24 S0	3RT10 25 S0	3RT10 26 S0
Ⓢ and Ⓤ ratings									
Rated insulation voltage		V AC	600			600			
Uninterrupted current, at 40 °C	• Open and enclosed	A	20			35			
Maximum horsepower ratings (Ⓢ and Ⓤ approved values)									
• Rated power for induction motors at 60 Hz		At 200 V hp	1.5	2	3	2	3	5	7.5
		230 V hp	2	3	3	3	3	5	7.5
		460 V hp	3	5	7.5	5	7.5	10	15
		575 V hp	5	7.5	10	7.5	10	15	20
Short-circuit protection¹⁾ (contactor or overload relay)	• CLASS RK5 fuse	At 600 V kA	5	5	5	5	5	5	5
	• Circuit breakers with overload protection acc. to UL 489	A	60	60	60	70	70	70	100
		A	50	50	50	70	70	70	100
• Combination motor controllers type E acc. to UL 508									
	- At 480 V	Type	--	--	--	3RV10 2			
		A	--	--	--	8	10	16	22
		kA	--	--	--	65	65	65	65
	- At 600 V	Type	--	--	--	3RV10 2			
		A	--	--	--	8	10	12.5	12.5
		kA	--	--	--	25	25	25	25
NEMA/EEMAC ratings									
NEMA/EEMAC size		hp	--		0	--			1
• Uninterrupted current	- Open	A	--		18	--			27
	- Enclosed	A	--		18	--			27
• Rated power for induction motors at 60 Hz		At 200 V hp	--		3	--			7.5
		230 V hp	--		3	--			7.5
		460 V hp	--		5	--			10
		575 V hp	--		5	--			10
Overload relay	• Type	A	3RU11 16			3RU11 2			
	• Setting range	A	0.11 ... 12			1.8 ... 25			

Contactors	Type Size		3RT10 34 S2	3RT10 35 S2	3RT10 36 S2	3RT10 44 S3	3RT10 45 S3	3RT10 46 S3
Ⓢ and Ⓤ ratings								
Rated insulation voltage		V AC	600			600		
Uninterrupted current, at 40 °C	• Open and enclosed	A	45	55	50	90	105	105
Maximum horsepower ratings (Ⓢ and Ⓤ approved values)								
• Rated power for induction motors at 60 Hz		At 200 V hp	10	10	15	20	25	30
		230 V hp	10	15	15	25	30	30
		460 V hp	25	30	40	50	60	75
		575 V hp	30	40	50	60	75	100
Short-circuit protection¹⁾ (contactor or overload relay)	• CLASS RK5 fuse	At 600 V kA	5	5	5	10	10	10
	• Circuit breakers with overload protection acc. to UL 489	A	125	150	200	250	300	350
		A	125	150	200	250	300	400
• Combination motor controllers type E acc. to UL 508								
	- At 480 V	Type	3RV10 3			3RV10 4		
		A	32	40	50	63	75	100
		kA	65	65	65	65	65	65
	- At 600 V	Type	3RV10 4			3RV10 4		
		A	32	40	50	63	75	75
		kA	25	25	25	30	30	30
NEMA/EEMAC ratings								
NEMA/EEMAC size		hp	--		2	--		3
• Uninterrupted current	- Open	A	--		45	--		90
	- Enclosed	A	--		45	--		90
• Rated power for induction motors with 60 Hz		At 200 V hp	--		10	--		25
		230 V hp	--		15	--		30
		460 V hp	--		25	--		50
		575 V hp	--		25	--		50
Overload relay	• Type	A	3RU11 3			3RU11 4		
	• Setting range	A	5.5 ... 50			18 ... 100		

¹⁾ For more information about short-circuit values, e. g. for protection against short-circuit currents, see the UL guides (Order No.: A5E02118883 for German) or UL reports (<http://www.siemens.com/lowvoltage/support>) for the individual devices.

3RT, 3TB, 3TF Contactors for Switching Motors

3RT10 contactors, 3-pole, 3 ... 250 kW

Contactors	Size	S00 Screw terminals and Cage Clamp terminals	S0 ... S12 Screw terminals and Cage Clamp terminals	Screw terminals and Cage Clamp terminals
		Integrated or snap-on auxiliary switch block	1- and 4-pole snap-on auxiliary switch block	Laterally mountable auxiliary switch block

UL and IEC ratings of the auxiliary contacts

Rated voltage	V AC	600	600	600
Switching capacity		A 600, Q 600	A 600, Q 600	A 300, Q 300
	• Uninterrupted current at 240 V AC	A	10	10

Contactors	Type Size	3RT10 54 S6	3RT10 55 S6	3RT10 56 S6	3RT10 64 S10	3RT10 65 S10	3RT10 66 S10
------------	--------------	----------------	----------------	----------------	-----------------	-----------------	-----------------

UL and IEC ratings

Rated insulation voltage	V AC	600			600			
Uninterrupted current, at 40 °C	• Open and enclosed	A	140	195	195	250	330	330
Maximum horsepower ratings (UL and IEC approved values)								
• Rated power for induction motors at 60 Hz		At 200 V hp	40	50	60	60	75	100
		230 V hp	50	60	75	75	100	125
		460 V hp	100	125	150	150	200	250
		575 V hp	125	150	200	200	250	300
Short-circuit protection¹⁾								
		At 600 V kA	10	10	10	10	18	18
	• CLASS RK5/L fuse	A	450	500	500	700	800	800
	• Circuit breakers with overload protection acc. to UL 489	A	350	450	500	500	700	800
NEMA/EEMAC ratings								
NEMA/EEMAC size		hp	--	4	--	--	--	5
• Uninterrupted current	- Open	A	--	150	--	--	--	300
	- Enclosed	A	--	135	--	--	--	270
• Rated power for induction motors with 60 Hz		At 200 V hp	--	40	--	--	--	75
		230 V hp	--	50	--	--	--	100
		460 V hp	--	100	--	--	--	200
		575 V hp	--	100	--	--	--	200
Overload relay	• Type		3RB20 56			3RB20 66		

Contactors	Type Size	3RT10 75 S12	3RT10 76 S12
------------	--------------	-----------------	-----------------

UL and IEC ratings

Rated insulation voltage	V AC	600		
Uninterrupted current, at 40 °C	• Open and enclosed	A	400	540
Maximum horsepower ratings (UL and IEC approved values)				
• Rated power for induction motors at 60 Hz		At 200 V hp	125	150
		230 V hp	150	200
		460 V hp	300	400
		575 V hp	400	500
Short-circuit protection¹⁾				
		At 600 V kA	18	30
	• CLASS L fuse	A	1000	1200
	• Circuit breakers with overload pro- tection acc. to UL 489	A	900	900
NEMA/EEMAC ratings				
NEMA/EEMAC size		hp	--	6
• Uninterrupted current	- Open	A	--	600
	- Enclosed	A	--	540
• Rated power for induction motors at 60 Hz		At 200 V hp	--	150
		230 V hp	--	200
		460 V hp	--	400
		575 V hp	--	400
Overload relay	• Type		3RB20 66	

¹⁾ For more information about short-circuit values, e. g. for protection against short-circuit currents, see the UL guide (Order No.: A5E02118883 for German) or UL reports (<http://www.siemens.com/lowvoltage/support>) for the individual devices.

Overview

- 3RT12 vacuum contactors for switching motors

Operating mechanism types

Two types of solenoid operation are available:

- Conventional operating mechanism, version 3RT12...A
- Solid-state operating mechanism, version 3RT12...N

UC operation

The contactors can be operated with AC (40 to 60 Hz) as well as with DC.

Withdrawable coils

For simple coil replacement, e. g. if the application is replaced, the magnetic coil can be pulled out upwards after the release mechanism has been actuated and can be replaced by any other coil of the same size.

Auxiliary contact complement

The contactors can be fitted with up to 8 lateral auxiliary contacts (identical auxiliary switch blocks from S0 to S12). Of these, no more than 4 are permitted to be NC contacts.

Function

3RT12 vacuum contactors

In contrast with the 3RT10 contactors – the main contacts operate in air under atmospheric conditions – the contact gaps of the 3RT12 vacuum contactors are contained in hermetically enclosed vacuum contact tubes. Neither arcs nor arcing gases are produced. The particular benefit of 3RT12 vacuum contactors, however, is that their electrical endurance is at least twice as long as that of 3RT10 contactors. They are therefore particularly well suited to frequent switching in jogging/mixed operation, for example in crane control systems.

Advantages:

- Very long electrical endurance
- High short-time loading capacity for heavy starting
- No reduction of rated operational currents up to 1000 V
- No open arcs, no arcing gases, i. e. no minimum clearances from grounded parts required either
- Longer maintenance intervals
- Increased plant availability

Notes on operation:

- *Switching motors with operational voltages $U_e > 500$ V: To damp overvoltages and protect the motor coil insulation against reignition when switching off induction motors, it is recommended to connect the 3RT19 66-1PV surge suppression module – RC varistor – to the outgoing side (2/T1, 4/T2, 6/T3) of the contactors (accessory). This additional equipment is not required for use in circuits with converters. It could be destroyed by the voltage peaks and harmonics which are generated.*
- *Switching DC voltage: Vacuum contactors are basically unsuitable for switching DC voltage.*

Contactors with conventional operating mechanism

3RT1...-A version:

The magnetic coil is switched directly on and off with the control supply voltage U_s by way of terminals A1/A2.

Multi-voltage range for the control supply voltage U_s :

Several closely adjacent control supply voltages, available around the world, are covered by just one coil, for example 110-115-120-127 V AC/DC or 220-230-240 V AC/DC.

In addition, allowance is also made for a coil operating range of 0.8 times the lower ($U_{s\ min}$) and 1.1 times the upper ($U_{s\ max}$) rated control supply voltage within which the contactor switches reliably and no thermal overloading occurs.

Contactors with solid-state operating mechanism

The magnetic coil is supplied selectively with the power required for reliable switching and holding by upstream control electronics.

- Wide voltage range for the control supply voltage U_s : Compared with the conventional operating mechanism, the solid-state operating mechanism covers an even broader range of control supply voltages used worldwide within one coil variant. For example, the coil for 200 to 277 V UC ($U_{s\ min}$ to $U_{s\ max}$) covers the voltages 200-208-220-230-240-254-277 V used worldwide.
- Extended operating range 0.7 to $1.25 \times U_s$: The wide range of the rated control supply voltage and the additional coil operating range of $0.8 \times U_{s\ min}$ to $1.1 \times U_{s\ max}$ results in an extended coil tolerance of at least 0.7 to $1.25 \times U_s$ for the most common control supply voltages 24, 110 and 230 V for which the contactors operate reliably.
- Bridging temporary voltage dips: Control voltage failures dipping to 0 V (at A1/A2) are bridged for up to approx. 25 ms to avoid unintentional tripping.
- Defined ON and OFF thresholds: For voltages of $\geq 0.8 \times U_{s\ min}$ and higher, the electronics will reliably switch the contactors on and off $\leq 0.5 \times U_{s\ min}$. The hysteresis in the switching thresholds prevents the main contacts from chattering as well as increased wear or welding when operated in weak, unstable networks. This also prevents thermal overloading of the contactor coil if the voltage applied is too low (contactor does not close properly and is continuously operated with overexcitation).
- Low control power consumption when closing and in the closed state.

Electromagnetic compatibility (EMC)

The contactors with solid-state operating mechanism conform to the requirements for operation in industrial plants.

- Interference immunity
 - Burst (IEC 61000-4-4): 4 kV
 - Surge (IEC 61000-4-5): 4 kV
 - Electrostatic discharge, ESD (IEC 61000-4-2): 8/15 kV
 - Electromagnetic field (IEC 61000-4-3): 10 V/m
- Emitted interference
 - Limit value class A according to EN 55011

Note:

In connection with converters, the control cables must be routed separately from the load cables to the converter.

3RT, 3TB, 3TF Contactors for Switching Motors

3RT12 vacuum contactors, 3-pole, 110 ... 250 kW

3RT1...-N version: for 24 V DC PLC output

2 control options:

- Control without a coupling link directly through a 24 V DC/≥ 30 mA PLC output (EN 61131-2). Connection by means of 2-pole plug-in connection. The screwless spring-type connection is part of the scope of supply. The control supply voltage which supplies the solenoid operating mechanism must be connected to A1/A2.

Note: Before start-up, the slide switch for PLC operation must be moved to the "PLC ON" position (setting ex works: "PLC OFF").

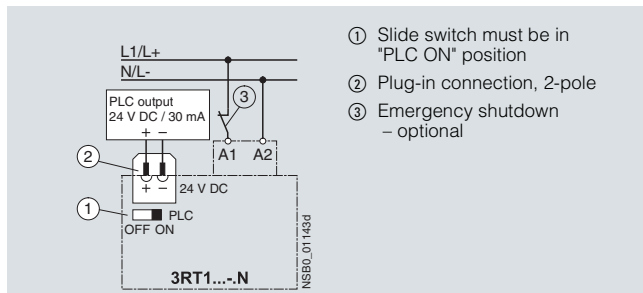

- Conventional control by applying the control supply voltage at A1/A2 through a switching contact.

Note: The slide switch must be in the "PLC OFF" position (= setting ex works).

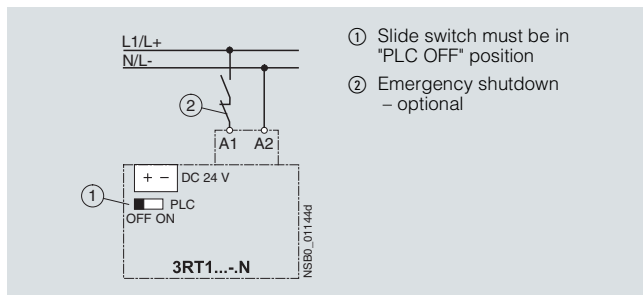

Vacuum contactors S10 and S12 contact erosion indication

If the contact erosion indicator on the contactor head part indicates an excessive erosion of the vacuum contact tubes (indicating line is on level with the tool symbol), the tubes must be replaced.

To ensure greater reliability, it is recommended to replace all 3 contact tubes.

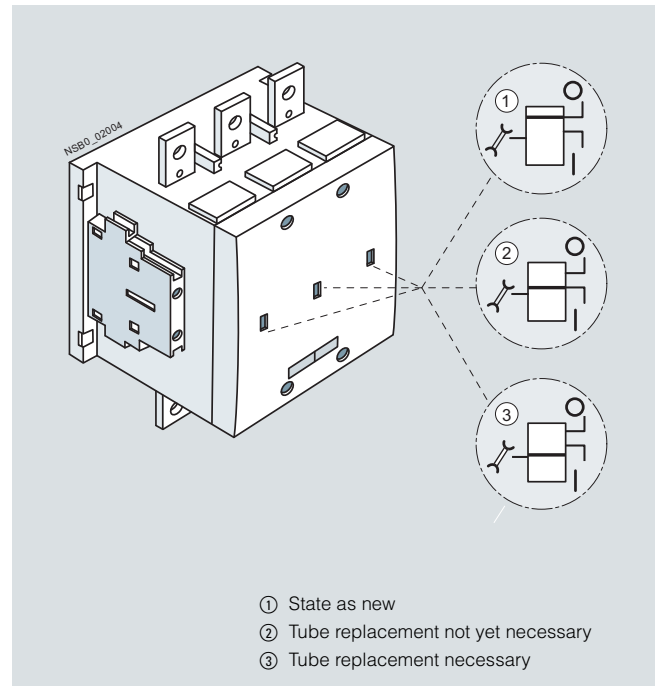

Technical specifications

Contactors	Type Size	3RT12 64 S10	3RT12 65 S10	3RT12 66 S10
General data				
Permissible mounting position The contactors are designed for operation on a vertical mounting surface.				
Mechanical endurance	Operating cycles	10 million		
Electrical endurance		1)		
Rated insulation voltage U_i (degree of pollution 3)	V	1000		
Rated impulse withstand voltage U_{imp}	kV	8		
Protective separation between the coil and the main contacts acc. to EN 60947-1, Appendix N	V	690		
Mirror contacts A mirror contact is an auxiliary NC contact that cannot be closed simultaneously with a NO main contact.		Yes, acc. to EN 60947-4-1, Appendix F		
Permissible ambient temperature	<ul style="list-style-type: none"> During operation During storage 	°C	-25 ... +60/+55 with AS-Interface	
		°C	-55 ... +80	
Degree of protection acc. to EN 60947-1, Appendix C		IP00/open, coil assembly IP20		
Touch protection acc. to EN 50274		Finger-safe with cover		
Shock resistance	<ul style="list-style-type: none"> Rectangular pulse Sine pulse 	g/ms g/ms	8.5/5 and 4.2/10 13.4/5 and 6.5/10	
Conductor cross-sections		2)		
Electromagnetic compatibility (EMC)		3)		

1) For endurance of the main contacts see page 3/19.

2) For conductor cross-sections see page 3/59.

3) For electromagnetic compatibility (EMC) see page 3/12.

3RT, 3TB, 3TF Contactors for Switching Motors

3RT12 vacuum contactors, 3-pole, 110 ... 250 kW

Contactors	Type Size	3RT12 64 S10	3RT12 65 S10	3RT12 66 S10
Short-circuit protection				
Main circuit				
Fuse links, gL/gG				
LV HRC 3NA, DIAZED 5SB, NEOZED 5SE				
acc. to IEC 60947-4-1/				
EN 60947-4-1				
	• Type of coordination "1"	A	500	
	• Type of coordination "2"	A	500	
	• Weld-free ¹⁾	A	400	
Auxiliary circuit				
	• Fuse links gL/gG	A	10	
DIAZED 5SB, NEOZED 5SE				
(weld-free protection for $I_k \geq 1$ kA)				
• Or miniature circuit breakers with C characteristic				
(short-circuit current I_k 400 A)				
¹⁾ Test conditions according to IEC 60947-4-1.				

Contactors	Type Size	3RT12 64 S10	3RT12 65 S10	3RT12 66 S10
Control				
Operating range of the solenoid AC/DC (UC)				
$0.8 \times U_{s \min} \dots 1.1 \times U_{s \max}$				
Power consumption of the solenoid				
(when coil is cool and rated range $U_{s \min} \dots U_{s \max}$)				
• Conventional operating mechanism				
- AC operation	Closing at $U_{s \min}$	VA/p.f.	530/0.9	
	Closing at $U_{s \max}$	VA/p.f.	630/0.9	
	Closed at $U_{s \min}$	VA/p.f.	6.1/0.9	
	Closed at $U_{s \max}$	VA/p.f.	7.4/0.9	
- DC operation	Closing at $U_{s \min}$	W	580	
	Closing at $U_{s \max}$	W	700	
	Closed at $U_{s \min}$	W	6.8	
	Closed at $U_{s \max}$	W	8.2	
• Solid-state operating mechanism				
- AC operation	Closing at $U_{s \min}$	VA/p.f.	420/0.8	
	Closing at $U_{s \max}$	VA/p.f.	570/0.8	
	Closed at $U_{s \min}$	VA/p.f.	4.3/0.8	
	Closed at $U_{s \max}$	VA/p.f.	5.6/0.8	
- DC operation	Closing at $U_{s \min}$	W	460	
	Closing at $U_{s \max}$	W	630	
	Closed at $U_{s \min}$	W	3.4	
	Closed at $U_{s \max}$	W	4.2	
PLC control input (EN 61131-2/type 2)				
24 V DC/≤ 30 mA power consumption, (operating range 17 ... 30 V DC)				
Operating times (Total break time = Opening delay + Arcing time)				
• Conventional operating mechanism				
- With $0.8 \times U_{s \min} \dots 1.1 \times U_{s \max}$	Closing delay	ms	30 ... 95	
	Opening delay	ms	40 ... 80	
- For $U_{s \min} \dots U_{s \max}$	Closing delay	ms	35 ... 50	
	Opening delay	ms	50 ... 80	
• Solid-state operating mechanism, actuated via A1/A2				
- With $0.8 \times U_{s \min} \dots 1.1 \times U_{s \max}$	Closing delay	ms	105 ... 145	
	Opening delay	ms	80 ... 100	
- For $U_{s \min} \dots U_{s \max}$	Closing delay	ms	110 ... 130	
	Opening delay	ms	80 ... 100	
• Solid-state operating mechanism, actuated via PLC input				
- With $0.8 \times U_{s \min} \dots 1.1 \times U_{s \max}$	Closing delay	ms	45 ... 80	
	Opening delay	ms	80 ... 100	
- For $U_{s \min} \dots U_{s \max}$	Closing delay	ms	50 ... 65	
	Opening delay	ms	80 ... 100	
• Arcing time				
		ms	10 ... 15	

3RT, 3TB, 3TF Contactors for Switching Motors

3RT12 vacuum contactors, 3-pole, 110 ... 250 kW





Contactors	Type Size	3RT12 64 S10	3RT12 65 S10	3RT12 66 S10
Main circuit				
AC capacity				
Utilization category AC-1				
Switching resistive loads				
• Rated operational currents I_e	At 40 °C up to 1000 V A	330		
	At 60 °C up to 1000 V A	300		
• Rated power for AC loads ¹⁾ P.f. = 0.95 (at 60 °C)	At 230 V kW	113		
	400 V kW	197		
	500 V kW	246		
	690 V kW	340		
	1000 V kW	492		
• Minimum conductor cross-section for loads with I_e	At 40 °C mm ²	185		
	At 60 °C mm ²	185		
Utilization category AC-2 and AC-3				
• Rated operational currents I_e	Up to 1000 V A	225	265	300
• Rated power for slipring or squirrel-cage motors at 50 and 60 Hz	At 230 V kW	73	85	97
	400 V kW	128	151	171
	500 V kW	160	189	215
	690 V kW	223	265	288
	1000 V kW	320	378	428
Thermal load capacity				
	10 s current ²⁾ A	1800	2120	2400
Power loss per conducting path				
	At I_e /AC-3 W	9	12	14
Utilization category AC-4 (for $I_a = 6 \times I_e$)				
• Rated operational current I_e	Up to 690 V A	195	230	280
• Rated power for squirrel-cage motors with 50 Hz and 60 Hz	At 400 V kW	110	132	160
• The following applies to a contact endurance of about 200 000 operating cycles:				
- Rated operational currents I_e	Up to 690 V A	97	115	140
	1000 V A	68	81	98
- Rated power for squirrel-cage motors with 50 Hz and 60 Hz	At 230 V kW	30	37	45
	400 V kW	55	65	79
	500 V kW	68	81	98
	690 V kW	94	112	138
	1000 V kW	95	114	140
Utilization category AC-6a				
Switching AC transformers				
Rated operational current I_e				
• For inrush current n = 20	Up to 690 V A	278		
• For inrush current n = 30	Up to 690 V A	185		
Rating P				
• For inrush current n = 20	At 230 V kVA	111		
	400 V kVA	193		
	500 V kVA	241		
	690 V kVA	332		
	1000 V kVA	482		
• For inrush current n = 30	At 230 V kVA	74		
	400 V kVA	128		
	500 V kVA	160		
	690 V kVA	221		
	1000 V kVA	320		
For deviating inrush current factors x, the power must be recalculated as follows: $P_x = P_{n30} \cdot 30/x$				
Utilization category AC-6b				
Switching low-inductance (low-loss, metallized dielectric) AC capacitors				
Ambient temperature 40 °C				
• Rated operational currents I_e	Up to 500 V A	220		
• Rated power for single capacitors or banks of capacitors (minimum inductance of 6 µH between capacitors connected in parallel) at 50 Hz, 60 Hz and	At 230 V kvar	88		
	400 V kvar	152		
	500 V kvar	191		
	690 V kvar	152		
Switching frequency				
Switching frequency z in operating cycles/hour				
• Contactors without overload relays	No-load switching frequency h ⁻¹	2000	2000	
Dependence of the switching frequency z' on the operational current I' and operational voltage U': $z' = z \cdot (I_e/I') \cdot (400 V/U')^{1.5} \cdot 1/h$	AC-1 h ⁻¹	800	750	
	AC-2 h ⁻¹	300	250	
	AC-3 h ⁻¹	750	750	
	AC-4 h ⁻¹	250	250	
• Contactors with overload relays (mean value)	h ⁻¹	60	60	

1) Industrial furnaces and electric heaters with resistance heating, etc. (increased power consumption on heating up taken into account).

2) According to IEC 60947-4-1.
For rated values for various start-up conditions see "Protection Equipment --> Overload Relays".

3RT, 3TB, 3TF Contactors for Switching Motors

3RT12 vacuum contactors, 3-pole, 110 ... 250 kW

Contactors	Type Size	3RT12 6. S10		
Main conductor cross-sections				
Front clamping point connected 	Main conductors: With 3RT19 66-4G box terminal		 Screw terminals	
	<ul style="list-style-type: none"> • Finely stranded with end sleeve • Finely stranded without end sleeve • Stranded • AWG cables, solid or stranded • Ribbon cable conductors (number x width x thickness) 	mm ² mm ² mm ² AWG mm		70 ...240 70 ...240 95 ...300 3/0 ...600 kcmil Min. 6 x 9 x 0.8, max. 20 x 24 x 0.5
Rear clamping point connected 	<ul style="list-style-type: none"> • Finely stranded with end sleeve • Finely stranded without end sleeve • Stranded • AWG cables, solid or stranded • Ribbon cable conductors (number x width x thickness) 		mm ² mm ² mm ² AWG mm Min. 6 x 9 x 0.8, max. 20 x 24 x 0.5	
	<ul style="list-style-type: none"> • Finely stranded with end sleeve • Finely stranded without end sleeve • Stranded • AWG cables, solid or stranded • Ribbon cable conductors (number x width x thickness) • Terminal screws - Tightening torque 	mm ² mm ² mm ² AWG mm Nm	120 ...185 120 ...185 120 ...240 250 ...500 kcmil Min. 2 x 50, max. 2 x 185 Min. 2 x 50, max. 2 x 185 Min. 2 x 70, max. 2 x 240 Min. 2 x 1/0, max. 2 x 500 kcmil Max. 2 x (20 x 24 x 0.5) M12 (hexagon socket, A/F 5) 20 ... 22 (180 ... 195 lb.in)	
Both clamping points connected 	Main conductors: Without box terminal/ busbar connection		M12 (hexagon socket, A/F 5) 20 ... 22 (180 ... 195 lb.in)	
	<ul style="list-style-type: none"> • Finely stranded with cable lug¹⁾ • Stranded with cable lug¹⁾ • AWG cables, solid or stranded • Connecting bar (max. width) • Terminal screws - Tightening torque 	mm ² mm ² AWG mm Nm		50 ...240 70 ...240 2/0 ...500 kcmil 25 M12 (hexagon socket, A/F 5) 14 ... 24 (124 ... 210 lb.in)
Auxiliary conductors:		<ul style="list-style-type: none"> • Solid • Finely stranded with end sleeve • AWG cables, solid or stranded • Terminal screws - Tightening torque 	mm ² mm ² AWG Nm	2 x (0.5 ... 1.5) ²⁾ ; 2 x (0.75 ... 2.5) ²⁾ acc. to IEC 60947; max. 2 x (0.75 ... 4) 2 x (0.5 ... 1.5) ²⁾ ; 2 x (0.75 ... 2.5) ²⁾ 2 x (18 ... 14) M3 (PZ 2) 0.8 ... 1.2 (7 ... 10.3 lb.in)

¹⁾ When connecting cable lugs according to DIN 46234 for conductor cross-sections of 185 mm² and more and according to DIN 46235 for conductor cross-sections of 240 mm² and more, the 3RT19 66-4EA1 terminal cover must be used more to keep the phase clearance.

²⁾ If two different conductor cross-sections are connected to one clamping point, both cross-sections must lie in the range specified. If identical cross-sections are used, this restriction does not apply.

3RT, 3TB, 3TF Contactors for Switching Motors

3RT12 vacuum contactors, 3-pole, 110 ... 250 kW

Contactors	Type Size	3RT12 75 S12	3RT12 76 S12
General data			
Permissible mounting position The contactors are designed for operation on a vertical mounting surface.			
Mechanical endurance	Operating cycles	10 million	
Electrical endurance		1)	
Rated insulation voltage U_i (degree of pollution 3)	V	1000	
Rated impulse withstand voltage U_{imp}	kV	8	
Protective separation between the coil and the main contacts acc. to EN 60947-1, Appendix N	V	690	
Mirror contacts A mirror contact is an auxiliary NC contact that cannot be closed simultaneously with a NO main contact.		Yes, acc. to EN 60947-4-1, Appendix F	
Permissible ambient temperature	<ul style="list-style-type: none"> • During operation • During storage 	°C	-25 ... +60/+55 with AS-Interface
		°C	-55 ... +80
Degree of protection acc. to EN 60947-1, Appendix C		IP00/open, coil assembly IP20	
Touch protection acc. to EN 50274		Finger-safe with cover	
Shock resistance	<ul style="list-style-type: none"> • Rectangular pulse • Sine pulse 	g/ms g/ms	8.5/5 and 4.2/10 13.4/5 and 6.5/10
Conductor cross-sections		2)	
Electromagnetic compatibility (EMC)		3)	
Short-circuit protection			
Main circuit			
Fuse links, gL/gG			
LV HRC 3NA, DIAZED 5SB, NEOZED 5SE			
acc. to IEC 60947-4-1/ EN 60947-4		• Type of coordination "1"	A 800
		• Type of coordination "2"	A 800
		• Weld-free ⁴⁾	A 500
Auxiliary circuit			
<ul style="list-style-type: none"> • Fuse links gL/gG DIAZED 5SB, NEOZED 5SE (weld-free protection for $I_k \geq 1$ kA) • Or miniature circuit breakers with C characteristic (short-circuit current $I_k < 400$ A) 		A	10

1) See endurance of the main contacts on page 3/19.

2) See conductor cross-sections on page 3/63.

3) See Electromagnetic Compatibility (EMC) on page 3/12.

4) Test conditions according to IEC 60947-4-1.

3RT, 3TB, 3TF Contactors for Switching Motors

3RT12 vacuum contactors, 3-pole, 110 ... 250 kW

Contactors	Type Size		3RT12 75 S12	3RT12 76 S12
Control				
Operating range of the solenoid	AC/DC (UC)		$0.8 \times U_{s \min} \dots 1.1 \times U_{s \max}$	
Power consumption of the solenoid (when coil is cool and rated range $U_{s \min} \dots U_{s \max}$)				
• Conventional operating mechanism				
- AC operation	Closing at $U_{s \min}$	VA/p.f.	700/0.9	
	Closing at $U_{s \max}$	VA/p.f.	830/0.9	
	Closed at $U_{s \min}$	VA/p.f.	7.6/0.9	
	Closed at $U_{s \max}$	VA/p.f.	9.2/0.9	
- DC operation	Closing at $U_{s \min}$	W	770	
	Closing at $U_{s \max}$	W	920	
	Closed at $U_{s \min}$	W	8.5	
	Closed at $U_{s \max}$	W	10	
• Solid-state operating mechanism				
- AC operation	Closing at $U_{s \min}$	VA/p.f.	560/0.8	
	Closing at $U_{s \max}$	VA/p.f.	750/0.8	
	Closed at $U_{s \min}$	VA/p.f.	5.4/0.8	
	Closed at $U_{s \max}$	VA/p.f.	7/0.8	
- DC operation	Closing at $U_{s \min}$	W	600	
	Closing at $U_{s \max}$	W	800	
	Closed at $U_{s \min}$	W	4	
	Closed at $U_{s \max}$	W	5	
PLC control input (EN 61131-2/type 2)			24 V DC/≤ 30 mA power consumption, (operating range 17 ... 30 V DC)	
Operating times (Total break time = Opening delay + Arcing time)				
• Conventional operating mechanism				
- With $0.8 \times U_{s \min} \dots 1.1 \times U_{s \max}$	Closing delay	ms	45 ... 100	
	Opening delay	ms	60 ... 100	
- For $U_{s \min} \dots U_{s \max}$	Closing delay	ms	50 ... 70	
	Opening delay	ms	70 ... 100	
• Solid-state operating mechanism, actuated via A1/A2				
- With $0.8 \times U_{s \min} \dots 1.1 \times U_{s \max}$	Closing delay	ms	120 ... 150	
	Opening delay	ms	80 ... 100	
- For $U_{s \min} \dots U_{s \max}$	Closing delay	ms	125 ... 150	
	Opening delay	ms	80 ... 100	
• Solid-state operating mechanism, actuated via PLC input				
- With $0.8 \times U_{s \min} \dots 1.1 \times U_{s \max}$	Closing delay	ms	60 ... 90	
	Opening delay	ms	80 ... 100	
- For $U_{s \min} \dots U_{s \max}$	Closing delay	ms	65 ... 80	
	Opening delay	ms	80 ... 100	
• Arcing time				
		ms	10 ... 15	
Main circuit				
AC capacity				
Utilization category AC-1				
Switching resistive loads				
• Rated operational currents I_e	At 40 °C up to 1000 V	A	610	
	At 60 °C up to 1000 V	A	550	
• Rated power for AC loads ¹⁾	At 230 V	kW	208	
P.f. = 0.95 (at 60 °C)	400 V	kW	362	
	500 V	kW	452	
	690 V	kW	624	
	1000 V	kW	905	
• Minimum conductor cross-section for loads with I_e	At 40 °C	mm ²	2 x 185	
	At 60 °C	mm ²	2 x 185	
Utilization category AC-2 and AC-3				
• Rated operational currents I_e	Up to 1000 V	A	400	500
• Rated power for slipping or squirrel-cage motors at 50 and 60 Hz	At 230 V	kW	132	164
	400 V	kW	231	291
	500 V	kW	291	363
	690 V	kW	400	507
	1000 V	kW	578	728
Thermal load capacity			10 s current ²⁾	A
			3200	4000
Power loss per conducting path			At I_e /AC-3	W
			21	32

¹⁾ Industrial furnaces and electric heaters with resistance heating, etc. (increased power consumption on heating up taken into account).

²⁾ According to IEC 60947-4-1.

For rated values for various start-up conditions see "Protection Equipment → Overload Relays".



3RT, 3TB, 3TF Contactors for Switching Motors

3RT12 vacuum contactors, 3-pole, 110 ... 250 kW

Contactor	Type Size			3RT12 75 S12	3RT12 76 S12
Main circuit					
AC capacity					
Utilization category AC-4 (for $I_a = 6 \times I_e$)					
• Rated operational current I_e	Up to 690 V	A		350	430
• Rated power for squirrel-cage motors with 50 Hz and 60 Hz	At 400 V	kW		200	250
• The following applies to a contact endurance of about 200 000 operating cycles:					
- Rated operational currents I_e	690 V	A		175	215
	1000 V	A		123	151
• Rated power for squirrel-cage motors with 50 Hz and 60 Hz	At 230 V	kW		56	70
	400 V	kW		98	122
	500 V	kW		124	153
	690 V	kW		172	212
	1000 V	kW		183	217
Utilization category AC-6a switching AC transformers					
• Rated operational current I_e					
- For inrush current n = 20	Up to 690 V	A		419	
- For inrush current n = 30	Up to 690 V	A		279	
• Rating P					
- For inrush current n = 20	At 230 V	kVA		167	
	400 V	kVA		290	
	500 V	kVA		363	
	690 V	kVA		501	
	1000 V	kVA		726	
- For inrush current n = 30	At 230 V	kVA		111	
	400 V	kVA		193	
	500 V	kVA		241	
	690 V	kVA		332	
	1000 V	kVA		482	
For deviating inrush current factors x, the power must be recalculated as follows: $P_x = P_{n30} \cdot 30/x$					
Utilization category AC-6b Switching low-inductance (low-loss, metallized dielectric) AC capacitors Ambient temperature 40 °C					
• Rated operational currents I_e	Up to 500 V	A		407	
• Rated power for single capacitors or banks of capacitors (minimum inductance of 6 μH between capacitors connected in parallel) at 50 Hz, 60 Hz and	At 230 V	kvar		162	
	400 V	kvar		282	
	500 V	kvar		352	
	690 V	kvar		282	
Switching frequency					
Switching frequency z in operating cycles/hour					
• Contactors without overload relays	No-load switching frequency	h ⁻¹		2000	
Dependence of the switching frequency z' on the operational current I' and operational voltage U' : $z' = z \cdot (I_e/I') \cdot (400 V/U')^{1.5} \cdot 1/h$					
	AC-1	h ⁻¹		700	
	AC-2	h ⁻¹		250	
	AC-3	h ⁻¹		750	
	AC-4	h ⁻¹		250	
• Contactors with overload relays (mean value)		h ⁻¹		60	

3RT, 3TB, 3TF Contactors for Switching Motors

3RT12 vacuum contactors, 3-pole, 110 ... 250 kW

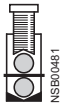
Contactors	Type Size	3RT12 7. S12	
Conductor cross-sections			
Front clamping point connected 	Main conductors: With 3RT19 66-4G box terminal	• Finely stranded with end sleeve mm ² • Finely stranded without end sleeve mm ² • Stranded mm ² • AWG cables, solid or stranded AWG • Ribbon cable conductors (number x width x thickness) mm	 Screw terminals 70 ... 240 70 ... 240 95 ... 300 3/0 ... 600 kcmil Min. 6 x 9 x 0.8, max. 20 x 24 x 0.5
	Rear clamping point connected 	• Finely stranded with end sleeve mm ² • Finely stranded without end sleeve mm ² • Stranded mm ² • AWG cables, solid or stranded AWG • Ribbon cable conductors (number x width x thickness) mm	120 ... 185 120 ... 185 120 ... 240 250 ... 500 kcmil Min. 6 x 9 x 0.8, max. 20 x 24 x 0.5
Both clamping points connected 	• Finely stranded with end sleeve mm ² • Finely stranded without end sleeve mm ² • Stranded mm ² • AWG cables, solid or stranded AWG • Ribbon cable conductors (number x width x thickness) mm	Min. 2 x 50, max. 2 x 185 Min. 2 x 50, max. 2 x 185 Min. 2 x 70, max. 2 x 240 Min. 2 x 2/0, max. 2 x 500 kcmil Max. 2 x (20 x 24 x 0.5)	
	• Terminal screws - Tightening torque Nm	M12 (hexagon socket, A/F 5) 20 ... 22 (180 ... 195 lb.in)	
	Main conductors: Without box terminal/ busbar connection	• Finely stranded with cable lug ¹⁾ mm ² • Stranded with cable lug ¹⁾ mm ² • AWG cables, solid or stranded AWG • Connecting bar (max. width) mm • Terminal screws - Tightening torque Nm	50 ... 240 70 ... 240 2/0 ... 500 kcmil 25 M10 x 30 (hexagon socket, A/F 17) 14 ... 24 (124 ... 240 lb.in)
	Auxiliary conductors:	• Solid mm ² • Finely stranded with end sleeve mm ² • AWG cables, solid or stranded AWG • Terminal screws - Tightening torque Nm	2 x (0.5 ... 1.5) ²⁾ ; 2 x (0.75 ... 2.5) ²⁾ acc. to IEC 60947; max. 2 x (0.75 ... 4) 2 x (0.5 ... 1.5) ²⁾ ; 2 x (0.75 ... 2.5) ²⁾ 2 x (18 ... 14) M3 (PZ 2) 0.8 ... 1.2 (7 ... 10.3 lb.in)

¹⁾ When connecting cable lugs to DIN 46234, the 3RT19 66-4EA1 terminal cover must be used for conductor cross-sections of 240 mm² and more as well as DIN 46235 for conductor cross-sections of 185 mm² and more to keep the phase clearance.

²⁾ If two different conductor cross-sections are connected to one clamping point, both cross-sections must lie in the range specified. If identical cross-sections are used, this restriction does not apply.

Contactors	Type Size	3RT12 64 S10	3RT12 65 S10	3RT12 66 S10	3RT12 75 S12	3RT12 76 S12
Ⓢ and Ⓛ ratings						
Rated insulation voltage	V AC	600			600	
Uninterrupted current, at 40 °C	• Open and enclosed	330			540	
Maximum horsepower ratings (Ⓢ and Ⓛ approved values)						
• Rated power for induction motors at 60 Hz	At 200 V hp 230 V hp 460 V hp 575 V hp	60 75 150 200	75 100 200 250	100 125 250 300	125 150 300 400	150 200 400 500
Short-circuit protection¹⁾	kA • CLASS L fuse • Circuit breakers acc. to UL 489	10 700 500	18 800 700	18 800 900	18 1200 1000	30 1200 1200
NEMA/EEMAC ratings	NEMA/EEMAC size	hp	--	5	--	6
• Uninterrupted current	- Open - Enclosed	A A	-- --	300 270	-- --	600 540
• Rated power for induction motors at 60 Hz	At 200 V hp 230 V hp 460 V hp 575 V hp	-- -- -- --	-- -- -- --	75 100 200 200	-- -- -- --	150 200 400 400
Overload relay	• Type	3RB20 66			3RB20 66	

¹⁾ For more information about short-circuit values, e. g. for protection against short-circuit currents, see the UL guide (Order No.: A5E02118883 for German) or UL reports (<http://www.siemens.com/lowvoltage/support>) for the individual devices.

3RT, 3TB, 3TF Contactors for Switching Motors

3TF6 vacuum contactors, 3-pole, 335 ... 450 kW

Overview

IEC 60947-4-1, EN 60947-4-1 (VDE 0660 Part 102)

The 3TF68/69 contactors are climate-proof. They are finger-safe according to EN 50274. Terminal covers may have to be fitted onto the connecting bars, depending on the configuration with other devices (see [Accessories and Spare Parts](#)).

Function

Main contacts

Contact erosion indication with 3TF68/69 vacuum contactors

The contact erosion of the vacuum interrupters can be checked during operation with the help of 3 white double slides on the contactor base. If the distance indicated by one of the double slides is < 0.5 mm while the contactor is in the closed position, the vacuum interrupter must be replaced. To ensure maximum reliability, it is recommended to replace all 3 vacuum interrupters.

Auxiliary contacts

Contact reliability

The auxiliary contacts are suitable for solid-state circuits

- With currents ≥ 1 mA
- And voltages from 17 V.

Surge suppression

Control circuit

Protection of coils against overvoltages:

AC operation

- Fitted with varistors as standard

DC operation

Retrofitting options:

- With varistors

If TF68/TF69 is to be used for DC operation, an additional reversing contactor is required; this is included in the scope of supply in the same packaging as the vacuum contactor.

Electromagnetic compatibility

3TF68/69...C contactors for AC operation are fitted with an electronically controlled solenoid operating mechanism with a high interference immunity.

Contactors type	Rated control supply voltage U_s	Overvoltage type (IEC 60801)	Degree of severity (IEC 60801)	Overvoltage strength
3TF68 44-C.., 3TF69 44-C..	110 ... 132 V	Burst	3	2 kV
		Surge	4	6 kV
	200 ... 277 V	Burst	4	4 kV
		Surge	4	5 kV
	380 ... 600 V	Burst	4	4 kV
		Surge	4	6 kV

Note:

During operation in installations in which the emitted interference limits cannot be observed, e. g. when used for output contactors in converters, 3TF68/69...Q contactors without a main conductor path circuit are recommended (see description below).

Application

The standard 3TF68...C and 3TF69...C contactors with electronically controlled contactor mechanism, have high resistance to electromagnetic interference.

The 3TF68...Q and 3TF69...Q contactors have been designed for use in installations in which the AC control supply voltage is subject to very high levels of interference.

Causes for such interference can be, for example:

- Frequency converters which are operated nearby can cause periodic overvoltages at the control level of the contactors.
- High-energy pulses caused by switching operations and atmospheric discharges can cause interference on the control cables.

To reduce interference voltages caused by frequency converters, the manufacturer recommends the use of e. g. input filters, output filters, grounding or shielding in the installation.

Further measures that should be applied for overvoltage damping:

- Feeding the contactors using control transformer according to EN 60204 - rather than directly from the network
- Use of surge arresters, if required

For operating conditions where there are high interference voltages and no measures that reduce interference voltage coupling to the control voltage level have been taken, use of 3TF68...Q and 3TF69...Q contactors is highly recommended.

Version

The magnetic systems of the 3TF68...Q and 3TF69...Q contactors for AC operation are equipped with rectifiers for DC economy circuit.

A 3TC44 reversing contactor with a mounted series resistor is used to switch to the holding excitation.

The reversing contactor can be fitted separately. The reversing contactors is connected to the 3TF6 main contactor by means of a one-meter connecting cable with plug-in connectors (see [page 3/239](#)).

Connection

Control circuit

The rectifier bridge is connected to varistors for protection against overvoltages. The built-in rectifier bridge affords sufficient protection for the coils.

Main circuit

As standard 3TF6 contactors with integrated RC varistors.

Protection of the main current paths

An integrated RC varistor connection for the main current paths of the contactors dampens the switching overvoltage rises to safe values. This prevents multiple restriking.

The operator of an installation can therefore rest assured that the motor winding cannot be damaged by switching overvoltages with steep voltage rises.

Note:

The overvoltage damping circuit is not required if 3TF68/69 contactors are used in circuits with DC choppers, frequency converters or speed-variable operating mechanisms, for example. It could be damaged by the voltage peaks and harmonics which are generated. This may cause phase-to-phase short-circuits in the contactors.

Solution: Order special contactor version without overvoltage damping. The Order No. must include "-Z" and the order code "A02". Without additional price.

3RT, 3TB, 3TF Contactors for Switching Motors

3TF6 vacuum contactors, 3-pole, 335 ... 450 kW

Technical specifications

Contactors	Type	3TF68 and 3TF69	
Rated data of the auxiliary contacts			
Rated insulation voltage U_i (degree of pollution 3)	V	690	
Continuous thermal current $I_{th} = \text{Rated operational current } I_e/\text{AC-12}$	A	10	
AC load			
Rated operational current $I_e/\text{AC-15/AC-14}$ • For rated operational voltage U_e			
	24 V A	10	
	110 V A	10	
	125 V A	10	
	220 V A	6	
	230 V A	5.6	
	380 V A	4	
	400 V A	3.6	
	500 V A	2.5	
	660 V A	2.5	
	690 V A	2.3	
DC load			
Rated operational current $I_e/\text{DC-12}$ • For rated operational voltage U_e			
	24 V A	10	
	60 V A	10	
	110 V A	3.2	
	125 V A	2.5	
	220 V A	0.9	
	440 V A	0.33	
	600 V A	0.22	
Rated operational current $I_e/\text{DC-13}$ • For rated operational voltage U_e			
	24 V A	10	
	60 V A	5	
	110 V A	1.14	
	125 V A	0.98	
	220 V A	0.48	
	440 V A	0.13	
	600 V A	0.07	
Ⓢ and Ⓛ ratings of the auxiliary contacts			
Rated voltage	V AC, max.	600	
Switching capacity		A 600, P 600	

3RT, 3TB, 3TF Contactors for Switching Motors

3TF6 vacuum contactors, 3-pole, 335 ... 450 kW

Endurance of the auxiliary contacts

The contact endurance for utilization category AC-12 or AC-15/AC-14 depends mainly on the breaking current. It is assumed that the operating mechanisms are switched randomly, i. e. not synchronized with the phase angle of the supply system.

3TF68 and 3TF69 contactors at 230 V AC

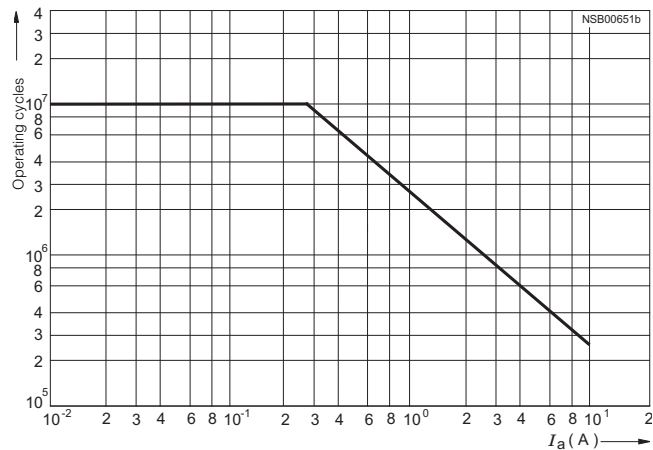

Contact erosion indication with 3TF68 and 3TF69 vacuum contactors

The contact erosion of the vacuum interrupters can be checked during operation with the help of 3 white double slides on the contactor base.

If the distance indicated by one of the double slides is < 0.5 mm while the contactor is in the closed position, the vacuum interrupter must be replaced. To ensure maximum reliability, it is recommended to replace all 3 vacuum interrupters.

Endurance of the main contacts

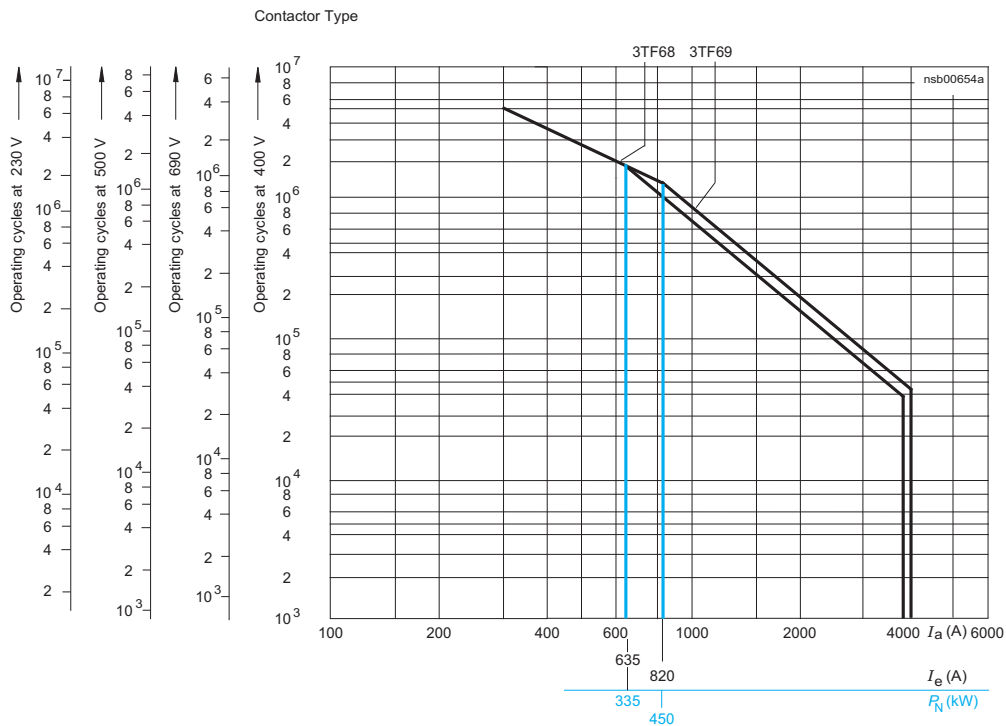

3TF68 and 3TF69 contactors

Diagram legend:

P_N = Rated power for squirrel-cage motors at 400 V

I_a = Breaking current

I_e = Rated operational current

3RT, 3TB, 3TF Contactors for Switching Motors

3TF6 vacuum contactors, 3-pole, 335 ... 450 kW

Contactors	Type Size		3TF68 14	3TF69 14
General data				
Permissible mounting position, installation instructions ^{1) 2)} The contactors are designed for operation on a vertical mounting surface.	AC operation and DC operation			
Mechanical endurance		Operating cycles	5 million	
Electrical endurance		Operating cycles	3)	
Rated insulation voltage U_i (degree of pollution 3)		kV	1	
Rated impulse withstand voltage U_{imp}		kV	8	
Protective separation between the coil and the main contacts acc. to EN 60947-1, Appendix N		kV	1	
Mirror contacts A mirror contact is an auxiliary NC contact that cannot be closed simultaneously with a NO main contact. One NC contact each must be connected in series for the right and left auxiliary switch block respectively.			Yes, acc. to EN 60947-4-1, Appendix F	
Permissible ambient temperature	<ul style="list-style-type: none"> • During operation • During storage 	°C	-25 ... +55	
		°C	-55 ... +80	
Degree of protection acc. to EN 60947-1, Appendix C			IP00/open, coil assembly IP40	
Touch protection acc. to EN 50274			Finger-safe with cover	
Shock resistance				
• Rectangular pulse	- AC operation	g/ms	8.1/5 and 4.7/10	9.5/5 and 5.7/10
	- DC operation	g/ms	9/5 and 5.7/10	8.6/5 and 5.1/10
• Sine pulse	- AC operation	g/ms	12.8/5 and 7.4/10	13.5/5 and 7.8/10
	- DC operation	g/ms	14.4/5 and 9.1/10	13.5/5 and 7.8/10
Conductor cross-sections			See "Conductor Cross-Sections".	
Electromagnetic compatibility (EMC)			See "Electromagnetic Compatibility (EMC)".	
Short-circuit protection				
Main circuit				
Fuse links, gL/gG				
LV HRC 3NA, DIAZED 5SB, NEOZED 5SE				
acc. to IEC 60947-4-1/				
EN 60947-4-1				
	• Type of coordination "1"	A	1000	1250
	• Type of coordination "2"	A	500	630
	• Weld-free ⁴⁾	A	400	500
Auxiliary circuit				
• Fuse links gL/gG		A	10	
LV HRC 3NA, DIAZED 5SB, NEOZED 5SE (weld-free protection at $I_k \geq 1$ kA)				
• Or miniature circuit breakers with C characteristic ($I_k < 400$ A)		A	10	

¹⁾ To easily replace the laterally mounted auxiliary switches it is recommended to maintain a minimum distance of 30 mm between the contactors.

²⁾ If mounted at a 90° angle (conducting paths are horizontally above each other), the switching frequency is reduced by 80 % compared with the normal values.

³⁾ See "Endurance of the Auxiliary Contacts".

⁴⁾ Test conditions according to IEC 60947-4-1.

3RT, 3TB, 3TF Contactors for Switching Motors

3TF6 vacuum contactors, 3-pole, 335 ... 450 kW

Contactor	Type Size		3TF68 14	3TF69 14
Control				
Magnetic coil operating range			$0.8 \times U_{s \min} \dots 1.1 \times U_{s \max}$	
Power consumption of the magnetic coils (when coil is cold and $1.0 \times U_s$)				
• AC operation, $U_{s \max}$	- Closing - Closed	VA/p.f. VA/p.f.	1850/1 49/0.15	950/0.98 30.6/0.31
• AC operation, $U_{s \min}$	- Closing - Closed	VA/p.f. VA/p.f.	1200/1 13.5/0.47	600/0.98 12.9/0.43
• DC economy circuit ¹⁾	- Closing at 24 V - Closed	W W	1010 28	960 20.6
<u>For contactors of type 3TF68/69...-Q:</u>				
• AC operation, $U_{s \min}$ ²⁾	- Closing - Closed	VA/p.f. VA/p.f.	1000/0.99 11/1	1150/0.99 11/1
Operating times at $0.8 \dots 1.1 \times U_s$ (Total break time = Opening delay + Arcing time)			(Values apply to cold and warm coil)	
• AC operation	- Closing delay - Opening delay	ms ms	70 ... 120 (22 ... 65) ³⁾ 70 ... 100	80 ... 120 70 ... 80
• DC economy circuit	- Closing delay - Opening delay	ms ms	76 ... 110 50	86 ... 280 19 ... 25
• Arcing time		ms	10 ... 15	10
<u>For contactors of type 3TF68/69...-Q:</u>				
• AC operation	- Closing delay - Opening delay	ms ms	35 ... 90 65 ... 90	45 ... 160 30 ... 80
Operating times at $1.0 \times U_s$ (Total break time = Opening delay + Arcing time)				
• AC operation	- Closing delay - Opening delay	ms ms	80 ... 100 (30 ... 45) ³⁾ 70 ... 100	85 ... 100 70
• DC economy circuit	- Closing delay - Opening delay	ms ms	80 ... 90 50	90 ... 125 19 ... 25
Minimum command duration for closing	Standard Reduced make-time	ms ms	120 90	120 --
Minimum interval time between two ON commands		ms	100	300

1) At 24 V DC; for further voltages, deviations of up to $\pm 10\%$ are possible.

2) Including reversing contactor.

3) Values in brackets apply to contactors with reduced operating times.

3RT, 3TB, 3TF Contactors for Switching Motors

3TF6 vacuum contactors, 3-pole, 335 ... 450 kW

Contactors	Type Size		3TF68 14	3TF69 14
Main circuit				
<i>AC capacity</i>				
Utilization category AC-1 Switching resistive loads				
• Rated operational currents I_e	At 40 °C up to 690 V	A	700	910
	At 55 °C up to 690 V	A	630	850
	At 55 °C up to 1000 V	A	450	800
• Rated power for AC loads with p.f. = 0.95 at 55°C	230 V	kW	240	323
	400 V	kW	415	558
	500 V	kW	545	735
	690 V	kW	720	970
	1000 V	kW	780	1385
• Minimum conductor cross-sections for loads with I_e	At 40°C	mm ²	2 x 240	$I_e \geq 800$ A: 2 x 60 x 5 (copper busbars)
	At 55°C	mm ²	2 x 185	$I_e < 800$ A: 2 x 240
Utilization category AC-2 and AC-3				
• Rated operational currents I_e	Up to 690 V	A	630	820
	1000 V	A	435	580
• Rated power for slipping or squirrel-cage motors at 50 Hz and 60 Hz	At 230 V	kW	200	260
	400 V	kW	347	450
	500 V	kW	434	600
	690 V	kW	600	800
	1000 V	kW	600	800
Utilization category AC-4 (for $I_a = 6 \times I_e$)				
• Rated operational current I_e	Up to 690 V	A	610	690
• Rated power for squirrel-cage motors with 50 Hz and 60 Hz	At 400 V	kW	355	400
• The following applies to a contact endurance of about 200 000 operating cycles:				
- Rated operational currents I_e	Up to 690 V	A	300	360
	1000 V	A	210	250
- Rated power for squirrel-cage motors with 50 Hz and 60 Hz	At 230 V	kW	97	110
	400 V	kW	168	191
	500 V ¹⁾	kW	210	250
	690 V ¹⁾	kW	278	335
	1000 V ¹⁾	A	290	350
Utilization category AC-6a switching AC transformers				
• Rated operational currents I_e	Up to 400 V			
- For inrush current n = 20		A	513	675
- For inrush current n = 30		A	342	450
• Rating P				
- For inrush current n = 20	230 V	kVA	195	256
	400 V	kVA	338	445
	500 V	kVA	444	584
	690 V	kVA	586	771
	1000 V	kVA	752	1003
- For inrush current n = 30 ²⁾	230 V	kVA	130	171
	400 V	kVA	226	297
	500 V	kVA	296	389
	690 V	kVA	390	514
	1000 V	kVA	592	778
Utilization category AC-6b, switching low-inductance (low-loss, metallized dielectric) AC capacitors				
• Rated operational currents I_e	Up to 400 V	A	433	
• Rated power for single capacitors at 50 and 60 Hz	At 230 V	kvar	175	
	400 V	kvar	300	
	500 V	kvar	400	
	690 V	kvar	300	
• Rated power for banks of capacitors (minimum inductance is 6 µH between capacitors connected in parallel) at 50 and 60 Hz	At 230 V	kvar	145	
	400 V	kvar	250	
	500 V	kvar	333	
	690 V	kvar	250	

¹⁾ Max. permissible rated operational current $I_e/AC-4 = I_e/AC-3$ up to 500 V, for reduced contact endurance and reduced switching frequency.

²⁾ For deviating inrush current factors x, the power must be recalculated as follows:
 $P_x = P_{n30} \cdot 30/x$.

3RT, 3TB, 3TF Contactors for Switching Motors

3TF6 vacuum contactors, 3-pole, 335 ... 450 kW

Contactor	Type Size	3TF68 14	3TF69 14		
Main circuit					
AC capacity					
Short-time loading capacity (5 ... 30 s)					
• CLASS 5 and 10	A	630	820		
• CLASS 15	A	630	662		
• CLASS 20	A	536	572		
• CLASS 25	A	479	531		
• CLASS 30	A	441	500		
Thermal current-carrying capacity 10-s-current ¹⁾	A	5040	7000		
Power loss per conducting path at $I_e/AC-3/690\text{ V}$	W	45	70		
Switching frequency					
Switching frequency z in operating cycles/hour					
• Contactors without overload relays	No-load switching frequency AC	1/h	2000	1000	
	No-load switching frequency DC	1/h	1000	1000	
	AC-1	1/h	700	700	
	AC-2	1/h	200	200	
	AC-3	1/h	500	500	
	AC-4	1/h	150	150	
• Contactors with overload relays (mean value)		1/h	15	15	
Conductor cross-sections					
Main conductors:		Screw terminals			
• Busbar connections					
- Finely stranded with cable lug	mm ²	50 ... 240	50 ... 240		
- Stranded with cable lug	mm ²	70 ... 240	50 ... 240		
- Solid or stranded	AWG	2/0 ... 500 MCM	2/0 ... 500 MCM		
- Connecting bar (max. width)	mm	50	60 ($U_e \leq 690\text{ V}$) 50 ($U_e > 690\text{ V}$)		
• Terminal screw					
- Tightening torque	Nm	M10 x 30 14 ... 24 (124 ... 210 lb.in)	M12 x 40 20 ... 35 (177 ... 310 lb.in)		
• With box terminal ²⁾					
- Connectable copper bars					
- Width	mm	15 ... 25	15 ... 38		
- Max. thickness	mm	1 x 26 or 2 x 11	1 x 46 or 2 x 18		
- Terminal screw		A/F 6 (hexagon socket)	A/F 8 (hexagon socket)		
- Tightening torque	Nm	25 ... 40 (221 ... 354 lb.in)	35 ... 50 (266 ... 443 lb.in)		
Auxiliary conductors:					
• Solid	mm ²	2 x (0.5 ... 1) ³⁾ /2 x (1 ... 2.5) ³⁾			
• Finely stranded with end sleeve	mm ²	2 x (0.5 ... 1) ³⁾ /2 x (0.75 ... 2.5) ³⁾			
• Pin-end connector to DIN 46231	mm ²	2 x (1 ... 1.5)			
• Solid or stranded	AWG	2 x (18 ... 12)			
• Tightening torque	Nm	0.8 ... 1.4 (7 ... 12 lb.in)			
and ratings					
Rated insulation voltage		V AC	600	600	
Uninterrupted current		• Open and enclosed	A	630	820
Maximum horsepower ratings (and approved values)					
• Rated power for induction motors at 60 Hz	At 200 V	hp	231	290	
	230 V	hp	266	350	
	460 V	hp	530	700	
	575 V	hp	664	860	
NEMA/EEMAC ratings					
SIZE		hp	6	7	
• Uninterrupted current	- Open	A	600	820	
	- Enclosed	A	540	810	
• Rated power for induction motors at 60 Hz	At 200 V	hp	150	--	
	230 V	hp	200	300	
	460 V	hp	400	600	
	575 V	hp	400	600	
Overload relay		• Type • Setting range	A	3RB12 . 200 ... 820	

For short-circuit protection with overload relays see "Protection Equipment --> Overload Relays".

¹⁾ According to IEC 60947-4-1.

²⁾ See Accessories and Spare Parts.

³⁾ If two different conductor cross-sections are connected to one clamping point, both cross-sections must lie in the range specified. If identical cross-sections are used, this restriction does not apply.

3RT, 3TB, 3TF Contactors for Switching Motors

3TB5 contactors with DC solenoid system,
3-pole, 55 ... 200 kW

Overview

*3TB5 contactors with DC solenoid system,
3-pole, 55 ... 200 kW*

EN 60947-4-1.

The contactors are climate-proof and finger-safe according to EN 50274.

Technical specifications

Contactors	Type	3TB50		3TB52 to 3TB56	
Rated data of the auxiliary contacts					
Acc. to IEC 60947-5-1 (VDE 0660 Part 200)					
Rated insulation voltage U_i (degree of pollution 3)	V	690			
Continuous thermal current I_{th} = Rated operational current $I_e/AC-12$	A	10			
AC load					
Rated operational current $I_e/AC-15/AC-14$					
• For rated operational voltage U_e					
	24 V	A	10		
	110 V	A	10		
	125 V	A	10		
	220 V	A	6		
	230 V	A	5.6		
	380 V	A	4		
	400 V	A	3.6		
	500 V	A	2.5		
	660 V	A	2.5		
	690 V	A	--		
DC load					
Rated operational current $I_e/DC-12$					
• For rated operational voltage U_e					
	24 V	A	10	10	
	60 V	A	10	10	
	110 V	A	3.2	8	
	125 V	A	2.5	6	
	220 V	A	0.9	2	
	440 V	A	0.33	0.6	
	600 V	A	0.22	0.4	
Rated operational current $I_e/DC-13$ ¹⁾					
• For rated operational voltage U_e					
	24 V	A	10 (10)	10 (10)	
	60 V	A	5 (7)	5 (4)	
	110 V	A	1.14 (3.2)	2.4 (1.8)	
	125 V	A	0.98 (2.5)	2.1 (1.6)	
	220 V	A	0.48 (0.9)	1.1 (0.9)	
	440 V	A	0.13 (0.33)	0.32 (0.27)	
	600 V	A	0.075 (0.22)	0.21 (0.18)	

Contactors	Type	3TB50 to 3TB56	
Ⓢ and Ⓣ ratings of the auxiliary contacts			
Rated voltage	V AC, max.	600	
Switching capacity		A 600, P 600	

¹⁾ Values in brackets apply to auxiliary contacts with delayed NC contact.

3RT, 3TB, 3TF Contactors for Switching Motors

3TB5 contactors with DC solenoid system, 3-pole, 55 ... 200 kW

Endurance of the main contacts

The characteristic curves show the contact endurance of the contactors when switching resistive and inductive AC loads (AC-1/AC-3) depending on the breaking current and rated operational voltage. It is assumed that the operating mechanisms are switched randomly, i. e. not synchronized with the phase angle of the supply system.

The rated operational current I_e complies with utilization category AC-4 (breaking six times the rated operational current) and is intended for a contact endurance of approx. 200 000 operating cycles.

If a shorter endurance is sufficient, the rated operational current I_e /AC-4 can be increased.

If the contacts are used for mixed operation, i. e. normal switching (breaking the rated operational current according to utilization category AC-3) in combination with intermittent inching (breaking several times the rated operational current according to utilization category AC-4), the contact endurance can be calculated approximately from the following equation:

$$X = \frac{A}{1 + \frac{C}{100} \left(\frac{A}{B} - 1 \right)}$$

Characters in the equation:

- X Contact endurance for mixed operation in operating cycles
- A Contact endurance for normal operation ($I_a = I_e$) in operating cycles
- B Contact endurance for inching ($I_a = \text{multiple of } I_e$) in operating cycles
- C Inching operations as a percentage of total switching operations

3TB50 to 3TB56 contactors

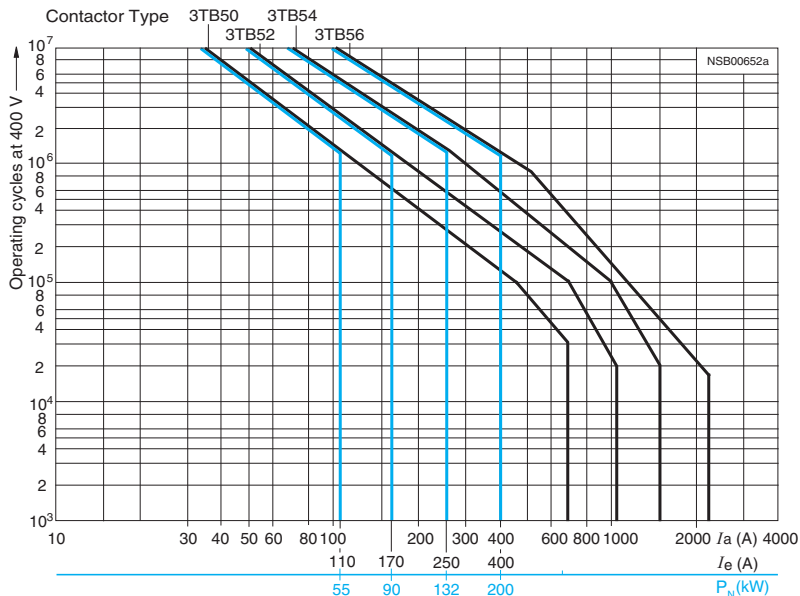

Diagram legend:

- P_N = Rated power for squirrel-cage motors at 400 V
- I_a = Breaking current
- I_e = Rated operational current

3

3RT, 3TB, 3TF Contactors for Switching Motors

3TB5 contactors with DC solenoid system,
3-pole, 55 ... 200 kW

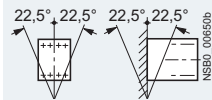
Contactors	Type Size	3TB50 6	3TB52 8	3TB54 10	3TB56 12		
General data							
Permissible mounting position Installation instructions¹⁾ The contactors are designed for operation on a vertical mounting surface.							
Mechanical endurance		Operating cycles	10 million				
Electrical endurance			2)				
Rated insulation voltage U_i		V	1000				
Protective separation between the coil and the main contacts acc. to EN 60947-1, Appendix N		V	690				
Mirror contacts A mirror contact is an auxiliary NC contact that cannot be closed simultaneously with a NO main contact.			Yes, acc. to EN 60947-4-1, Appendix F				
Permissible ambient temperature		°C	-25 ... +55				
		°C	-50 ... +80				
Degree of protection acc. to EN 60947-1, Appendix C			IP00 (open), coil assembly IP40				
Touch protection acc. to EN 50274			Finger-safe with cover				
Shock resistance (rectangular pulse)		g/ms	5/10	5.9/10	5.9/10	5.9/10	
Short-circuit protection							
Main circuit							
Fuse links gL/gG		• Type of coordination "1"	A	250	315	400	630
LV HRC 3NA, DIAZED 5SB		• Type of coordination "2"	A	224	250	315	500
Auxiliary circuit short-circuit current $I_k \geq 1$ kA							
• Fuse links gL/gG, DIAZED 5SB, NEOZED 5SE		A	16				
• Miniature circuit breaker with C characteristic		A	10				
Control							
Magnetic coil operating range			0.8 ... 1.1 x U_s				
Power consumption of the magnetic coil (for cold coil and 1.0 x U_s) Closing = Closed		W	25	30	60	86	
Operating times at 0.8 ... 1.1 x U_s Total break time = Opening delay + Arcing time			(The values apply up to and including 20 % undervoltage, 10 % overvoltage, as well as when the coil is cold and warm)				
• Closing delay		ms	105 ... 360	115 ... 400	105 ... 400	110 ... 400	
• Opening delay ³⁾		ms	18 ... 30	22 ... 35	24 ... 55	40 ... 110	
• Arcing time		ms	10 ... 15	10 ... 15	10 ... 15	10 ... 15	
Operating times at 1.0 x U_s							
• Closing delay		ms	120 ... 230	130 ... 250	115 ... 250	120 ... 250	
• Opening delay ³⁾		ms	20 ... 26	24 ... 32	35 ... 50	60 ... 95	
Main circuit							
AC capacity							
Utilization category AC-1, switching resistive loads							
• Rated operational current I_e		At 40 °C up to 690 V A	170	230	325	425	
		At 55 °C up to 690 V A	160	200	300	400	
• Rated power for AC loads ⁴⁾ P.f. = 0.95 (at 55 °C)		230 V kW	61	76	114	152	
		400 V kW	105	132	195	262	
		500 V kW	138	173	260	345	
		690 V kW	183	228	340	455	
• Minimum conductor cross-sections for loads with I_e		mm ²	70	95	185	240	
Utilization category AC-2 and AC-3							
5)							
Utilization category AC-4 (for $I_a = 6 \times I_e$)							
• The following applies to a contact endurance of about 200 000 operating cycles:							
- Rated operational current I_e		A	52	72	103	120	
- Rated power for squirrel-cage motors with 50 Hz and 60 Hz		230 V kW	15.6	21	31	37.5	
		400 V kW	27	37	55	65	
		500 V kW	35	48	72	85.5	
		690 V kW	45	64	92	106	
- Max. rated operational current I_e /AC-4		At 400 V A	110	170	250	400	

¹⁾ For reversing duty, deviations from the vertical axis are not permitted.

²⁾ See "Endurance of the Main Contacts".

³⁾ The opening delay times can increase if the contactor coils are damped against voltage peaks.

⁴⁾ Industrial furnaces and electric heaters with resistance heating, etc. (increased power consumption on heating up has been taken into account).

⁵⁾ See selection table in Catalog LV 1.

3RT, 3TB, 3TF Contactors for Switching Motors

3TB5 contactors with DC solenoid system, 3-pole, 55 ... 200 kW

Contactors	Type Size		3TB50 6	3TB52 8	3TB54 10	3TB56 12
Main circuit						
AC capacity						
Switching low-inductance (low-loss, metallized dielectric) AC capacitors¹⁾						
• Rated operational current I_{θ} at 400 V		A	87	144	217	289
• Rated power for single capacitors at 50 Hz	230 V	kvar	35	58	87	115
	400 V	kvar	60	100	150	200
	500 V	kvar	80	130	190	265
	690 V	kvar	60	100	150	200
• Rated power for banks of capacitors (minimum inductance is 6 μ H between capacitors connected in parallel) at 50 Hz	230 V	kvar	30	40	66	85
	400 V	kvar	50	70	115	150
	500 V	kvar	66	90	145	195
	690 V	kvar	50	70	115	150
Load rating with DC						
Utilization category DC-1						
Switching resistive loads ($L/R \leq 1$ ms)						
• Rated operational current I_{θ} (at 55 °C)						
- 1 conducting path	24 V	A	160	200	300	400
	60 V	A	80	80	300	330
	110 V	A	18	18	33	33
	220 V	A	3.4	3.4	3.8	3.8
	440 V	A	0.8	0.8	0.9	0.9
	600 V	A	0.5	0.5	0.6	0.6
- 2 conducting paths in series	24 V	A	160	200	300	400
	60 V	A	160	200	300	400
	110 V	A	160	200	300	400
	220 V	A	20	20	300	400
	440 V	A	3.2	3.2	4	4
	600 V	A	1.6	1.6	2	2
- 3 conducting paths in series	24 V	A	160	200	300	400
	60 V	A	160	200	300	400
	110 V	A	160	200	300	400
	220 V	A	160	200	300	400
	440 V	A	11.5	11.5	11	11
	600 V	A	4	4	5.2	5.2
Utilization category DC-3/DC-5						
Shunt-wound and series-wound motors ($L/R \leq 15$ ms)						
• Rated operational current I_{θ} (at 55 °C)						
- 1 conducting path	24 V	A	16	16	35	35
	60 V	A	7.5	7.5	11	11
	110 V	A	2.5	2.5	3	3
	220 V	A	0.6	0.6	0.6	0.6
	440 V	A	0.17	0.17	0.18	0.18
	600 V	A	0.12	0.12	0.125	0.125
- 2 conducting paths in series	24 V	A	160	200	300	400
	60 V	A	160	200	300	400
	110 V	A	160	200	300	400
	220 V	A	2.5	2.5	2.5	2.5
	440 V	A	0.65	0.65	0.65	0.65
	600 V	A	0.37	0.37	0.37	0.37
- 3 conducting paths in series	24 V	A	160	200	300	400
	60 V	A	160	200	300	400
	110 V	A	160	200	300	400
	220 V	A	160	200	300	400
	440 V	A	1.4	1.4	1.4	1.4
	600 V	A	0.75	0.75	0.75	0.75
Switching frequency						
Switching frequency z in operating cycles/hour						
• Contactors without overload relays	AC-1	h ⁻¹	1000			
	AC-2	h ⁻¹	500			
	AC-3	h ⁻¹	500			
	AC-4	h ⁻¹	250			
• Contactors with overload relays (mean value)		h ⁻¹	15			

¹⁾ Contact endurance 0.1 million operating cycles.

3RT, 3TB, 3TF Contactors for Switching Motors

3TB5 contactors with DC solenoid system,
3-pole, 55 ... 200 kW

Contactors	Type Size		3TB50 6	3TB52 8	3TB54 10	3TB56 12
Conductor cross-sections						
Main conductors:			⊕ Screw terminals			
• Finely stranded with cable lug	mm ²		16 ... 70	35 ... 95	50 ... 240	50 ... 240
• Stranded with cable lug	mm ²		25 ... 70	50 ... 120	70 ... 240	70 ... 240
• Busbars	mm		15 x 3	20 x 3	25 x 5	2 x (25 x 3)
• Terminal screw			M6	M8	M10	M10
Auxiliary conductors:						
• Solid	mm ²		1 ... 2.5			
• Finely stranded with end sleeve	mm ²		0.75 ... 1.5			
• Pin-end connector (DIN 46231)	mm ²		2 x 1 ... 2.5			
Protective conductors:						
Stranded with cable lug	mm ²		--	25 ... 70	35 ... 70	50 ... 120
Ⓢ and Ⓣ ratings						
Ⓢ rating						
• Uninterrupted current	- Open	A	150	170	240	300
	- Enclosed	A	135	153	215	270
• Rated power for induction motors at 60 Hz (enclosed)	115 V	hp	25	30	40	50
	230 V	hp	50	60	75	100
	460 V	hp	100	120	150	200
	575 V	hp	125	160	200	250
• Overload relay	- Type		3RB20 56	3RB20 56	3RB20 66	3RB20 66
	- Setting range	A	50 ... 200	50 ... 200	50 ... 250	200 ... 540
• NEMA/EEMAC size	- Contactors		4	4	4	5
	- Starters (= contactors + overload relay, enclosed)		3	4	4	5
Ⓣ rating						
• Uninterrupted current	- Open	A	150	150	240	390
	- Enclosed	A	135	135	215	350
• Rated power for induction motors at 60 Hz	115 V	hp	25	25	30	--
	230 V	hp	50	50	75	125
	460 V	hp	100	100	150	250
	575 V	hp	125	125	200	300 ¹⁾
• Overload relay	- Type		3RB20 56	3RB20 56	3RB20 66	3RB20 66
	- Setting range	A	50 ... 200	50 ... 200	50 ... 250	200 ... 540
• NEMA/EEMAC size	- Contactors		4	4	4	5
	- Starters (= contactors + overload relay, enclosed)		3	4	4	5
Short-circuit protection devices						
• CLASS RK5 fuses		A	400	400	450	600
• Circuit breakers acc. to UL 489		A	175	175	250	600

¹⁾ At 575/600 V AC max.
rated motor current 325 A and
motor starting current 3250 A.

3RT, 3TB, 3TF Contactors for Switching Motors

3TF2 contactors, 3-pole, 2.2 ... 4 kW

Overview

AC and DC operation

IEC 60947 (VDE 0660).

The contactors are suitable for use in any climate. The contactors with screw terminals are finger-safe according to EN 50274.

The contactors are available in versions with screw terminals, 6.3 mm plug-in terminals and solder pin connections for soldering in printed circuit boards.

Design

Auxiliary contacts

Contact reliability

To switch voltages ≤ 110 V and currents ≤ 100 mA the 3TF2 contactor relays should be used as they guarantee a high level of contact reliability.

These auxiliary contacts are suitable for solid-state circuits with currents ≥ 1 mA at a voltage of 17 V and higher.

Short-circuit protection of the contactors

For short-circuit protection of the contactors without overload relays see "Technical specifications".

Version

The 3TF2 contactors are available with SIGUT screw terminals, 6.3 mm x 0.8 mm flat connectors and solder pin connectors.

The contactors with 6.3 mm x 0.8 mm flat connectors can be used in the plug-in base with solder pin connectors for printed circuit boards. The contactors are coded and the plug-in base is codable in order to ensure non-interchangeability.

Auxiliary switch blocks

The contactors with 1 auxiliary contact with screw terminals can be expanded by up to four contacts by the addition of snap-on auxiliary switch blocks.

The contactors according to EN 50012 with identification number 10E can be expanded into contactors with 2, 4 and 5 auxiliary contacts according to EN 50012 using auxiliary switch blocks.

The identification numbers 11E, 22E, 23E and 32E on the auxiliary switch blocks apply to the complete contactors (see the graphic on the right). These auxiliary switch blocks cannot be combined with contactors with identification number 01E.

All contactors with screw terminals and 1 auxiliary contact according to EN 50012, identification number 10E and 01E, can be extended with auxiliary switch blocks 40, 31, 22, 20, 11 and 02 to obtain contactors with 3 or 5 auxiliary contacts according to EN 50005. The identification numbers on the auxiliary switch blocks apply only to the attached auxiliary switches.

3TF20-0 motor contactors according to EN 50012 or EN 50005

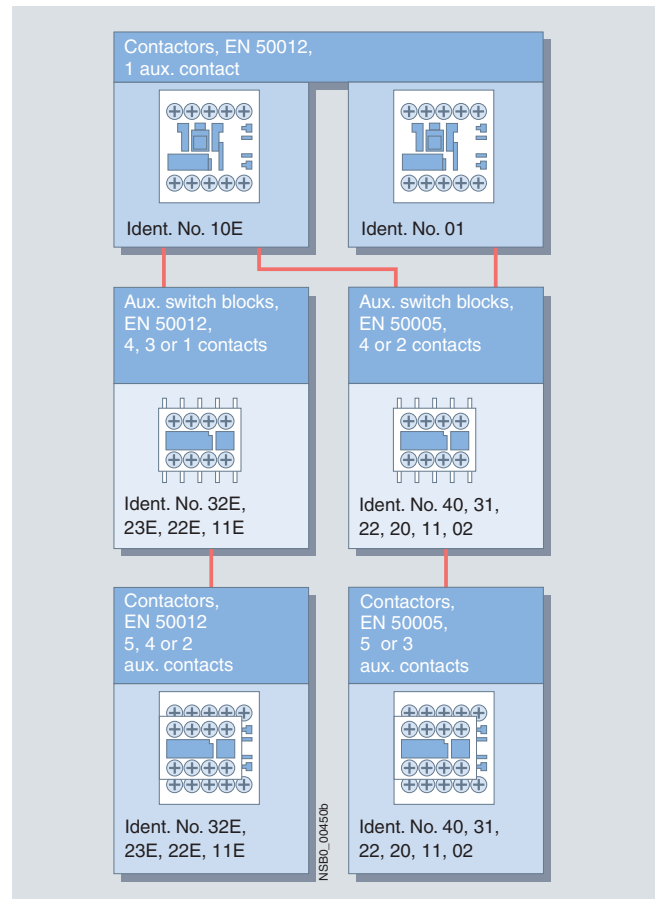

Surge suppression

RC elements, varistors, diodes or diode assemblies (combination of a diode and a Zener diode for short break times) can be plugged onto all 3TF2 contactors and auxiliary switch blocks with screw terminals from the front in order to damp opening surges in the coil. The unit labeling plate must be removed for this purpose. It can be snapped onto the attached surge suppressor.

Note:

The OFF-delay of the NO contacts and the ON-delay of the NC contacts increase if the contactor coils are protected against voltage peaks (noise suppression diode 6 to 10 times, diode assemblies 2 to 6 times, varistor +2 to 5 ms).

Reversing duty

To use the 3TF2 AC-operated contactor in reversing or Dahlander mode an additional dead interval of 50 ms is required along with an NC contact interlock.

3RT, 3TB, 3TF Contactors for Switching Motors

3TF2 contactors, 3-pole, 2.2 ... 4 kW

Technical specifications

Contactors Type **3TF2**

Endurance of the auxiliary contacts

The contact endurance for utilization category AC-12 or AC-15/AC-14 depends mainly on the breaking current. It is assumed that the operating mechanisms are switched randomly, i. e. not synchronized with the phase angle of the supply system. Diagram legend:

I_a = Breaking current
 I_e = Rated operational current

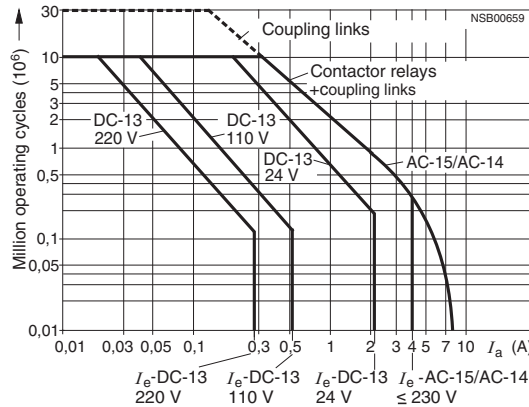

3TF2

Endurance of the main contacts

The characteristic curves show the contact endurance of the contactors when switching inductive AC loads (AC-3) depending on the breaking current and rated operational voltage. It is assumed that the operating mechanisms are switched randomly, i. e. not synchronized with the phase angle of the supply system.

The rated operational current I_e complies with utilization category AC-4 (breaking six times the rated operational current) and is intended for a contact endurance of at least 200 000 operating cycles. If a shorter endurance is sufficient, the rated operational current $I_e/AC-4$ can be increased.

If the contacts are used for mixed operation, i. e. normal switching (breaking the rated operational current according to utilization category AC-3) in combination with intermittent inching (breaking several times the rated operational current according to utilization category AC-4), the contact endurance can be calculated approximately from the following equation:

$$X = \frac{A}{1 + \frac{C}{100} \left(\frac{A}{B} - 1 \right)}$$

Characters in the equation:

X = Contact endurance for mixed operation in operating cycles

A = Contact endurance for normal operation ($I_a = I_e$) in operating cycles

B = Contact endurance for inching

(I_a = multiple of I_e) in operating cycles

C = Inching operations as a percentage of total switching operations

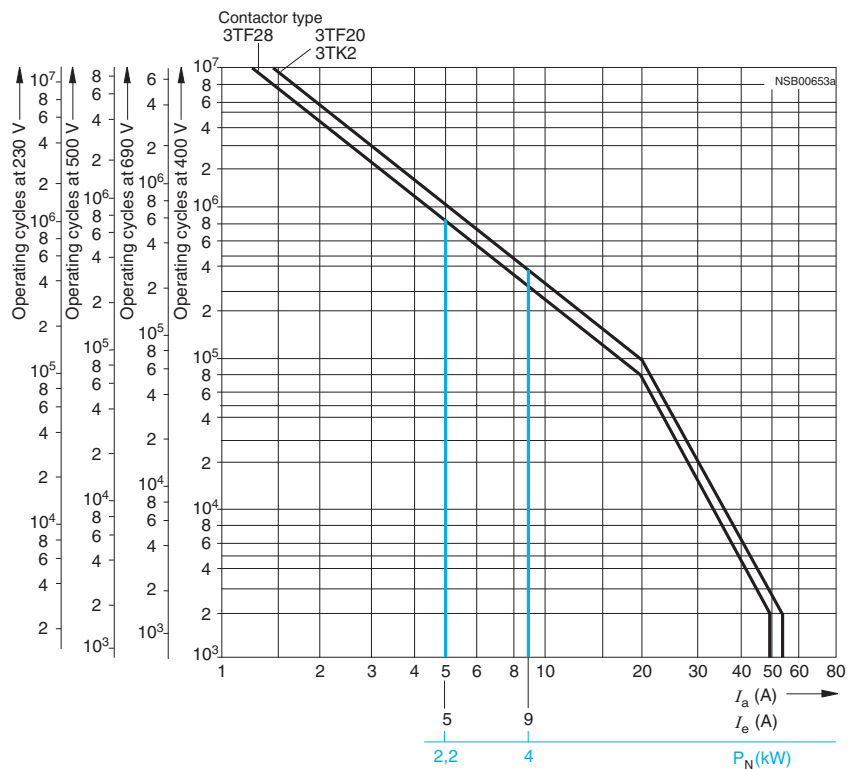

Diagram legend:

P_N = Rated power for squirrel-cage motors at 400 V

I_a = Breaking current

I_e = Rated operational current

3RT, 3TB, 3TF Contactors for Switching Motors

3TF2 contactors, 3-pole, 2.2 ... 4 kW

Contactors	Type		3TF20/3TF28	3TF22/3TF29
General data				
Permissible mounting position	AC and DC operation		Any	
Mechanical endurance	<ul style="list-style-type: none"> AC operation DC operation Auxiliary switch block 	Operating cycles	10 million 30 million 10 million	
Rated insulation voltage U_i (degree of pollution 3)				
	• Screw terminals	V	690	690 ¹⁾
	• Flat connector 6.3 mm x 0.8 mm	V	500	--
	• Solder pin connections	V	500	--
Rated impulse withstand voltage U_{imp} (degree of pollution 3)				
	• Screw terminals	kV	8	8 ²⁾
	• Flat connector 6.3 mm x 0.8 mm	kV	6	--
	• Solder pin connections	kV	6	--
Protective separation between coil and main contacts (acc. to EN 61140)		V	Up to 300	
Mirror contacts A mirror contact is an auxiliary NC contact that cannot be closed simultaneously with a NO main contact.			Yes, this applies to both the basic unit as well as to between the basic unit and the mounted auxiliary switch block acc. to EN 60947-4-1, Appendix F	Yes, acc. to EN 60947-4-1 Appendix F SUVA
Permissible ambient temperature ³⁾	<ul style="list-style-type: none"> During operation During storage 	°C °C	-25 ... +55 -55 ... +80	
Degree of protection acc. to EN 60947-1 Appendix C			IP00 open IP20 for screw terminals IP40 coil assembly	
Touch protection acc. to EN 50274			Finger-safe for screw terminals	
Shock resistance				
• Without 3TX44 auxiliary switch block				
- Rectangular pulse	- AC operation	g/ms	8.3/5 and 5.2/10	--
	- DC operation	g/ms	11.3/5 and 9.2/10	--
- Sine pulse	- AC operation	g/ms	13/5 and 8/10	--
	- DC operation	g/ms	17.4/5 and 12.9/10	--
• With 3TX44 auxiliary switch block				
- Rectangular pulse	- AC operation	g/ms	5/5 and 3.6/10	5/5 and 3.6/10
	- DC operation	g/ms	9/5 and 6.9/10	9/5 and 7.3/10
- Sine pulse	- AC operation	g/ms	7.8/5 and 5.6/10	7.8/5 and 5.6/10
	- DC operation	g/ms	13.9/5 and 10.1/10	14/5 and 11/10
Conductor cross-sections 4)				
Short-circuit protection for contactors without overload relays				
Main circuit ⁵⁾				
• Fuse links gL/gG LV HRC 3NA, DIAZED 5SB, NEOZED 5SE acc. to IEC 60947-4-1 (VDE 0660, Part 102)				
	- Type of coordination "1"	A	25	
	- Type of coordination "2" ⁶⁾	A	10	
	- Weld-free	A	10	
• Miniature circuit breaker with C characteristic				
		A	10	
Auxiliary circuit Short-circuit current $I_k \geq 1$ kA				
• Fuse links gL/gG DIAZED 5SB, NEOZED 5SE				
		A	6	

1) Auxiliary contacts 500 V.

2) Auxiliary contacts 6 kV.

3) Applies to 50/60 Hz coil:
At 50 Hz, $1.1 \times U_n$, side-by-side mounting and 100 % ON period the max. ambient temperature is +40 °C.

4) See "Conductor Cross-Sections".

5) According to excerpt from IEC 60947-4-1 (VDE 0660 Part 102)

Type of coordination "1":

Destruction of the contactor and the overload relay is permissible. The contactor and/or overload relay can be replaced if necessary.

Type of coordination "2":

The overload relay must not suffer any damage. Contact welding on the contactor is permissible, however, if the contacts can be easily separated.

6) A short-circuit current of $I_q \leq 6$ kA applies to type of coordination "2".

3RT, 3TB, 3TF Contactors for Switching Motors

3TF2 contactors, 3-pole, 2.2 ... 4 kW

Contactors	Type	3TF2	
Control			
Magnetic coil operating range¹⁾		0.8 ... 1.1 x U_s	
Power consumption of the magnetic coils (when coil is cold and 1.0 x U_s)			
Standard version:			
• AC operation, 50 Hz	Closing	VA	15
	P.f.		0.41
Closed		VA	6.8
	P.f.		0.42
• AC operation, 60 Hz	Closing	VA	14.4
	P.f.		0.36
Closed		VA	6.1
	P.f.		0.46
• AC operation, 50/60 Hz ¹⁾	Closing	VA	16.5/13.2
	P.f.		0.43/0.38
Closed		VA	8.0/5.4
	P.f.		0.48/0.42
For USA and Canada:			
• AC operation, 50 Hz	Closing	VA	14.6
	P.f.		0.38
Closed		VA	6.5
	P.f.		0.40
• AC operation, 60 Hz	Closing	VA	14.4
	P.f.		0.30
Closed		VA	6.0
	P.f.		0.44
• DC operation	Closing = Closed	W	3
Permissible residual current of the electronic circuit²⁾ (for 0 signal)			
	• AC operation	mA	$\leq 3 \times (230 \text{ V}/U_s)$
	• DC operation	mA	$\leq 1 \times (230 \text{ V}/U_s)$
Operating times at 0.8 ... 1.1 x U_s³⁾			
Total break time = Opening delay + Arcing time			
Values apply with coil in cold state and at operating temperature for operating range			
• AC operation	Closing delay	ms	5 ... 19
	Opening delay	ms	2 ... 22
- Dead interval			To use the 3TF2 AC-operated contactor in reversing an additional dead interval of 50 ms is required along with an NC contact interlock.
• DC operation	Closing delay	ms	16 ... 65
	Opening delay	ms	2 ... 5
• Arcing time		ms	10 ... 15
Operating times at 1.0 x U_s³⁾			
• AC operation	Closing delay	ms	5 ... 18
	Opening delay	ms	3 ... 21
- Dead interval			To use the 3TF2 AC-operated contactor in reversing an additional dead interval of 50 ms is required along with an NC contact interlock.
• DC operation	Closing delay	ms	19 ... 31
	Opening delay	ms	3 ... 4
• Arcing time		ms	10 ... 15

¹⁾ Applies to 50/60 Hz coil:
At 50 Hz, 1.1 x U_s , side-by-side mounting and 100 % ON period the max. ambient temperature is +40 °C.

²⁾ The 3TX4 490-1J additional load module is recommended for higher residual currents (see "Accessories and Spare Parts").

³⁾ The OFF-delay of the NO contact and the ON-delay of the NC contact are increased if the contactor coils are attenuated against voltage peaks (noise suppression diode 6 to 10 times; diode assemblies 2 to 6 times, varistor +2 to 5 ms).

3RT, 3TB, 3TF Contactors for Switching Motors

3TF2 contactors, 3-pole, 2.2 ... 4 kW

Contactor	Type		3TF28 3TF29	3TF20 ...-0..., 3TF22 ...-0...	3TF20 ...-3..., 3TF20 ...-6..., 3TF20 ...-7... S00
	Size		S00	S00	S00
Main circuit					
<i>AC capacity</i>					
Utilization category AC-1					
Switching resistive loads					
• Rated operational current I_e (at 40 °C)	Up to 400/380 V	A	18	18	18
	690/660 V	A	18	18	--
• Rated operational current I_e (at 55 °C)	400/380 V	A	16	16	16
	690/660 V	A	16	16	--
• Rated power of AC loads P.f. = 1	At 230/220 V	kW	6.0	6.0	6.0
	400/380 V	kW	10	10	10
	500 V	kW	13	13	13
	690/660 V	kW	17	17	--
• Minimum conductor cross-section for loads with I_e		mm ²	2.5	2.5	2.5
Utilization category AC-2 and AC-3					
• Rated operational current I_e	Up to 220 V	A	5.1	9.0	9.0
	230 V	A	5.1	9.0	9.0
	380 V	A	5.1	9.0	9.0
	400 V	A	5.1	8.4	8.4
	500 V	A	4.8	6.5	6.5
	660 V	A	4.8	5.2	--
	690 V	A	4.8	5.2	--
	• Rated power for motors with slipping or squirrel cage at 50 and 60 Hz and	At 110 V	kW	0.7	1.2
115 V		kW	0.7	1.2	1.2
120 V		kW	0.7	1.3	1.3
127 V		kW	0.8	1.4	1.4
200 V		kW	1.2	2.2	2.2
220 V		kW	1.3	2.4	2.4
230 V		kW	1.4	2.5	2.5
240 V		kW	1.5	2.6	2.6
380 V		kW	2.2	4.0	4.0
400 V		kW	2.2	4.0	4.0
415 V		kW	2.5	4.0	4.0
440 V		kW	2.5	4.0	4.0
460 V		kW	2.7	4.0	4.0
500 V		kW	2.9	4.0	4.0
575 V	kW	3.2	4.0	--	
660 V	kW	3.8	4.0	--	
690 V	kW	4.0	4.0	--	
Utilization category AC-4					
(contact endurance approx. 200 000 operating cycles at $I_a = 6 \times I_e$)					
• Rated operational current I_e	Up to 400 V	A	1.9	2.6	2.6
	690 V	A	1.4	1.8	--
• Rated power for motors with squirrel cage at 50 and 60 Hz and	At 110 V	kW	0.23	0.32	0.32
	115 V	kW	0.24	0.33	0.33
	120 V	kW	0.26	0.35	0.35
• Max. permissible rated operational current $I_e/AC-4 \cong I_e/AC-3$ up to 500 V, for reduced contact endurance and reduced switching frequency	127 V	kW	0.27	0.37	0.37
	200 V	kW	0.42	0.58	0.58
	220 V	kW	0.47	0.64	0.64
	230 V	kW	0.49	0.67	0.67
	240 V	kW	0.51	0.70	0.70
	380 V	kW	0.81	1.10	1.10
	400 V	kW	0.85	1.15	1.15
	415 V	kW	0.93	1.20	1.20
	440 V	kW	1.0	1.27	1.27
	460 V	kW	1.0	1.33	1.33
	500 V	kW	1.1	1.45	1.45
	575 V	kW	1.0	1.30	--
660 V	kW	0.86	1.10	--	
690 V	kW	0.89	1.15	--	



3RT, 3TB, 3TF Contactors for Switching Motors

3TF2 contactors, 3-pole, 2.2 ... 4 kW

Contactors	Type	3TF28 3TF29	3TF20 ..-0... 3TF22 ..-0...	3TF20 ..-3... 3TF20 ..-6... 3TF20 ..-7...
	Size	S00	S00	S00
Main circuit				
AC capacity				
Utilization category AC-5a				
Switching gas discharge lamps				
Per main current path at 230/220 V				
• Rated power per lamp	Rated operational current per lamp (A)			
- Uncorrected				
L 18 W	0.37	Units 43		
L 36 W	0.43	Units 37		
L 58 W	0.67	Units 23		
- DUO switching				
L 18 W	0.11	Units 144		
L 36 W	0.21	Units 76		
L 58 W	0.32	Units 50		
Switching gas discharge lamps with correction, solid-state ballast				
Per main current path at 230/220 V				
• Rated power per lamp	Capacitance (µF)	Rated operational current per lamp (A)		
- Parallel correction				
L 18 W	4.5	0.11	Units 22	
L 36 W	4.5	0.21	Units 22	
L 58 W	7	0.31	Units 14	
- With solid-state ballast (single lamp)				
L 18 W	6.8	0.10	Units 63	
L 36 W	6.8	0.18	Units 35	
L 58 W	10	0.27	Units 23	
- With solid-state ballast (two lamps)				
L 18 W	10	0.18	Units 35	
L 36 W	10	0.35	Units 18	
L 58 W	22	0.52	Units 12	
Utilization category AC-5b, switching incandescent lamps		kW	1.6	--
Per main current path at 230/220 V				
Utilization category AC-6a, switching AC transformers				
• Rated operational current I_e				
- For inrush current n = 20		At 400 V A	2.9	5.1
- For inrush current n = 30		At 400 V A	1.9	3.3
• Rated power P				
- For inrush current n = 20		Up to 230/220 V kVA	1.14	2.0
		400/380 V kVA	2	3.5
		500 V kVA	4.1	4.6
		690/660 V kVA	5.4	6.0
- For inrush current n = 30		Up to 230/220 V kVA	0.74	1.3
		400/380 V kVA	1.3	2.3
		500 V kVA	2.8	3.1
		690/660 V kVA	3.6	4.0
For deviating inrush current factors x, the power must be recalculated as follows: $P_x = P_{n30} \times (30/x)$				
Utilization category AC-6b				
Switching low-inductance (low-loss, metallized dielectric) AC capacitors				
No switching capacity				
Utilization category AC-7a				
Switching low inductive loads in household appliances				
• Rated operational current I_e (at 55 °C)		At 400/380 V A	16	16
		690/660 V A	16	--
• Rated power at 50 and 60 Hz		At 230/220 V kW	6	6
		400/380 V kW	10	10
• Minimum conductor cross-section for loads with I_e		mm ²	2.5	2.5
Utilization category AC-7b				
Switching motor loads in household appliances				
• Rated operational current I_e		Up to 220 V A	5.1	9.0
		230 V A	5.1	9.0
		380 V A	5.1	9.0
		400 V A	5.1	8.4
• Rated power of motors at 50 and 60 Hz and		At 110 V kW	0.68	1.2
		220 V kW	1.3	2.4
		230 V kW	1.4	2.5
		240 V kW	1.5	2.6
		380 V kW	2.2	4.0
		400 V kW	2.4	4.0

3RT, 3TB, 3TF Contactors for Switching Motors

3TF2 contactors, 3-pole, 2.2 ... 4 kW

Contactor	Type	3TF28 3TF29	3TF20 ...-0..., 3TF22 ...-0...	3TF20 ...-3..., 3TF20 ...-6..., 3TF20 ...-7...
	Size	S00	S00	S00
Main circuit				
<i>Load rating with DC</i>				
Utilization category DC-1				
Switching resistive loads				
(contact endurance 0.1×10^6 operating cycles; $L/R \leq 1$ ms)				
• Rated operational current I_{θ} (at 55 °C)				
- 1 conducting path	Up to 24 V A 60 V A 110 V A 220/240 V A	10 4 1.5 0.6	16 6 2 1	16 6 2 1
- 2 conducting paths in series	Up to 24 V A 60 V A 110 V A 220/240 V A	10 10 4 1.5	16 16 6 2	16 16 6 2
- 3 conducting paths in series	Up to 24 V A 60 V A 110 V A 220/240 V A	10 10 10 4	16 16 16 6	16 16 16 6
Utilization category DC-3 and DC-5				
Shunt-wound and series-wound motors ($L/R \leq 15$ ms)				
• Rated operational current I_{θ} (at 55 °C)				
- 1 conducting path	Up to 24 V A 60 V A 110 V A 220/240 V A	4 1.8 0.3 --	6 3 0.5 0.1	6 3 0.5 0.1
- 2 conducting paths in series	Up to 24 V A 60 V A 110 V A 220/240 V A	6 3 1.5 0.3	10 5 2 0.5	10 5 2 0.5
- 3 conducting paths in series	Up to 24 V A 60 V A 110 V A 220/240 V A	10 10 10 1.5	16 16 16 2	16 16 16 2
Thermal load capacity	10 s current A	70		
Power loss per conducting path	At $I_{\theta}/AC-3$ W	0.3		
<i>Switching frequency</i>				
Switching frequency z in operating cycles/hour				
• Contactors without overload relays	No-load switching frequency	h ⁻¹	10000	
Dependence of the switching frequency z' on the operational current I' and operational voltage U':	AC-1	h ⁻¹	1000	
$z' = z \cdot (I_{\theta}/I') \cdot (400 V/U')^{1.5} \cdot 1/h$	AC-2	h ⁻¹	500	
	AC-3	h ⁻¹	1000	
• Contactors with overload relays (mean value)		h ⁻¹	15	
Conductor cross-sections				
Main and auxiliary conductors				
• Solid		mm ²	 Screw terminals 2 x (0.5 ... 2.5), 1 x 4 2 x (20 ... 14) AWG, 1 x 12 AWG	
• Finely stranded with end sleeve		mm ²	2 x (0.5 ... 1.5), 1 x 2.5	
• Pin-end connector (DIN 46231)		mm ²	1 x 1 ... 2.5	
• Terminal screw			M3	
• Prescribed tightening torque for terminal screws		Nm	0.8 ... 1.3 (7 ... 11lb.in)	
• When using a plug-in sleeve	6.3 ... 1	mm ²	 Flat connectors 0.5 ... 1	
• Finely stranded	6.3 ... 2.5	mm ²	1 ... 2.5	
 Solder pin connections (only for printed circuit boards)				

3RT, 3TB, 3TF Contactors for Switching Motors

3TF2 contactors, 3-pole, 2.2 ... 4 kW

Contactor	Type	3TF20 ...-0...	3TF20 ...-3..., 3TF20 ...-6..., 3TF20 ...-7... S00
	Size	S00	S00
Ⓢ and Ⓣ rated data of the 3TF20 contactors			
Rated insulation voltage U_i	V AC	600	300
Uninterrupted current	• Open and enclosed A	16	16 (10 for solder pin connection)
Maximum horsepower ratings (Ⓢ and Ⓣ approved values)			
• Rated power for induction motors at 60 Hz			
- 1-phase	At 115 V hp	0.5	--
	200 V hp	1	1
	230 V hp	1.5	1
	460/575 V hp	--	--
- 3-phase	At 115 V hp	--	--
	200 V hp	3	3 (1 for 3TF20 ...-6)
	230 V hp	3	3 (1 for 3TF20 ...-6)
	460/575 V hp	5	--
Overload relay	• Type/Setting range	3UA7/EB 8 ... 10 A	

Contactor	Type	3TF2
	Size	
Rated data of the auxiliary contacts acc. to IEC 60947-5-1 (VDE 0660 Part 200)		
Rated insulation voltage U_i (degree of pollution 3)	V	690
Continuous thermal current $I_{th} =$ Rated operational current $I_e/AC-12$	A	10
AC load		
Rated operational current $I_e/AC-15/AC-14$		
• For rated operational voltage U_e		
	24 V A	4
	110 V A	4
	125 V A	4
	220 V A	4
	230 V A	4
	380 V A	3
	400 V A	3
	500 V A	2
	660 V A	1
	690 V A	1
DC load		
Rated operational current $I_e/DC-12$		
• For rated operational voltage U_e		
	24 V A	4
	48 V A	2.2
	110 V A	1.1
	125 V A	1.1
	220 V A	0.5
	440 V A	--
	600 V A	--
Rated operational current $I_e/DC-13$		
• For rated operational voltage U_e		
	24 V A	2.1
	48 V A	1.1
	110 V A	0.52
	125 V A	0.52
	220 V A	0.27
	440 V A	--
	600 V A	--
Ⓢ, Ⓣ and Ⓜ rated data of the auxiliary contacts		
Rated voltage, max.	V AC	600
Auxiliary switch blocks, max.	V AC	300
Switching capacity		A 600, Q 300
Uninterrupted current at 240 V AC	A	10

3RA13, 3RA14 Contactor Assemblies

3RA13 Reversing Contactor Assemblies

3RA13 complete units, 3 ... 45 kW

Overview

The 3RA13 reversing contactor assemblies can be ordered as follows:

Sizes S00 to S3

Fully wired and tested, with mechanical and electrical interlock. For assemblies with AC operation and 50/60 Hz, a dead interval of 50 ms must be provided when used with voltages ≥ 500 V; a dead interval of 30 ms is recommended for use with voltages ≥ 400 V. These dead times do not apply to assemblies with DC operation.

Sizes S00 to S12

As individual parts for customer assembly.

There is also a range of accessories (auxiliary switch blocks, surge suppressors, etc.) that must be ordered separately.

For overload relays for motor protection, see "Protection Equipment --> Overload Relays".

The 3RA13 contactor assemblies have screw terminals and are suitable for screwing or snapping onto 35 mm standard mounting rails.

Complete units

The fully wired reversing contactor assemblies are suitable for use in any climate. They are finger-safe according to EN 50274.

The contactor assemblies consist of 2 contactors with the same power, with one NC contact in the basic unit. The contactors are mechanically and electrically interlocked (NC contact interlock).

For motor protection, either 3RU11 or 3RB2... overload relays for direct mounting or stand-alone installation or thermistor motor protection tripping units must be ordered separately.

Components for customer assembly

Assembly kits for all sizes are available for customer assembly of reversing contactor assemblies.

Contactors, overload relays, the mechanical interlock (as of size S0) and – for momentary-contact operation – auxiliary switch blocks for latching must be ordered separately.

Rated data AC-2 and AC-3 at AC 50 Hz 400 V		Size	Order No.				Assembly kit	Fully wired and tested contactor assemblies
Rating kW	Operational current I_e A		Contactors	Mechanical interlock ¹⁾	Mechanical interlock ²⁾	Mechanical interlock ³⁾		
3	7	S00	3RT10 15	-- ⁴⁾	--	--	3RA19 13-2A ⁵⁾	3RA13 15-8XB30-1 .. 3RA13 16-8XB30-1 .. 3RA13 17-8XB30-1 ..
4	9		3RT10 16					
5.5	12		3RT10 17					
5.5	12	S0	3RT10 24	3RA19 24-1A	3RA19 24-2B	--	3RA19 23-2A ⁶⁾	3RA13 24-8XB30-1 .. 3RA13 25-8XB30-1 .. 3RA13 26-8XB30-1 ..
7.5	17		3RT10 25					
11	25		3RT10 26					
15	32	S2	3RT10 34	3RA19 24-1A	3RA19 24-2B	--	3RA19 33-2A ⁷⁾	3RA13 34-8XB30-1 .. 3RA13 35-8XB30-1 .. 3RA13 36-8XB30-1 ..
18.5	40		3RT10 35					
22	50		3RT10 36					
30	65	S3	3RT10 44	3RA19 24-1A	3RA19 24-2B	--	3RA19 43-2A ⁷⁾	3RA13 44-8XB30-1 .. 3RA13 45-8XB30-1 .. 3RA13 46-8XB30-1 ..
37	80		3RT10 45					
45	95		3RT10 46					
55	115	S6	3RT10 54	--	--	3RA19 54-2A	3RA19 53-2M ⁸⁾	--
75	150		3RT10 55					
90	185		3RT10 56					
110	225	S10	3RT10 64	--	--	3RA19 54-2A	3RA19 63-2A ⁸⁾	--
132	265		3RT10 65					
160	300		3RT10 66					
200	400	S12	3RT10 75	--	--	3RA19 54-2A	3RA19 73-2A ⁸⁾	--
250	500		3RT10 76					

1) Can be mounted onto the front.

2) Laterally mountable with one auxiliary contact.

3) Laterally mountable without auxiliary contact.

4) Interlock can only be ordered with assembly kit.

5) Assembly kit contains: mechanical interlock; connecting clips for 2 contactors; wiring modules on the top and bottom.

6) Assembly kit contains: wiring modules on the top and bottom.

7) Assembly kit contains: 2 connecting clips for contactors; wiring modules on the top and bottom.

8) Assembly kit contains: wiring module on the top and bottom.

3RA13, 3RA14 Contactor Assemblies

3RA13 Reversing Contactor Assemblies

3RA13 complete units, 3 ... 45 kW

Function

The operating times of the individual 3RT10 contactors are rated in such a way that no overlapping of the contact making and the arcing time between two contactors can occur on reversing, providing they are interlocked by way of their auxiliary switches (NC contact interlock) and the mechanical interlock. For assemblies with AC operation and 50/60 Hz, a dead interval of 50 ms must be provided when used with voltages ≥ 500 V; a dead interval of 30 ms is recommended for use with voltages ≥ 400 V. These dead times do not apply to assemblies with DC operation.

The operating times of the individual contactors are not affected by the mechanical interlock.

The following points should be noted:

Size S00

- For maintained-contact operation:
Use contactors with an NC contact in the basic unit for the electrical interlock.
- For momentary-contact operation:
Use contactors with an NC contact in the basic unit for the electrical interlock; in addition, an auxiliary switch block with at least one NO contact for latching is required per contactor.

Sizes S0 to S3

- For maintained-contact operation:
The contactors have no auxiliary contact in the basic unit; NC contacts for the electrical interlock are therefore integrated in the mechanical interlock that can be mounted on the side of each contactor (one contact each for the left and right-hand contactors).
- For momentary-contact operation:
Electrical interlock as for maintained-contact operation; for the purpose of latching an auxiliary contact with an NO contact is additionally required for each contactor. This contact can be snapped onto the top of the contactors. Alternatively, auxiliary switch blocks mounted on the side can be used; they must be fitted onto the outside of each contactor.

If the front-mounted mechanical interlock is used for size S0 to S3 contactors, two location holes for single-pole auxiliary switch blocks are provided on the front of each S0 or S2 contactor, while three additional, single-pole auxiliary switch blocks can be snapped onto S3 contactors. The maximum auxiliary switch fittings per contactor must not be exceeded.

When size S2 and S3 contactors are combined with a front-mounted mechanical interlock, the assembly kits for 3RA19 33-2B and 3RA19 43-2B contactor assemblies cannot be used.

Sizes S6 to S12

To insert the mechanical interlock, the prestamped location holes positioned opposite on the contactor must be knocked out. The internal auxiliary contacts (up to 1 NO + 1 NC per contactor) can be used for the electrical interlock and latching. The mechanical interlock itself does not contain any auxiliary contacts. Additional auxiliary contacts can be used on the outside and front (on the front in the case of 3RT10) of the reversing contactor assembly.

Surge suppression

Sizes S00 to S3

All contactor assemblies can be fitted with RC elements or varistors for damping opening surges in the coil.



As with the individual contactors, the surge suppressors can either be plugged onto the top of the contactors (S00) or fitted onto the coil terminals on the top or bottom (S0 to S3).

Sizes S6 to S12

The contactors are fitted with varistors as standard.

Technical specifications

The technical specifications are identical to those of the 3RT10 .. contactors listed on page 3/17 onwards.

The  and  approvals only apply to the complete contactor assemblies and not to the individual parts for customer assembly.

3RA13, 3RA14 Contactor Assemblies

3RA14 Contactor Assemblies for Wye-Delta Starting

3RA14 complete units, 3 ... 75 kW

Overview

These 3RA14 contactor assemblies for wye-delta starting are designed for standard applications.

Note:

Contact assemblies for wye-delta starting in special applications such as very heavy starting or wye-delta starting of special motors must be customized. Help with designing such special applications is available from Technical Assistance.

The 3RA14 contactor assemblies for wye-delta starting can be ordered as follows:

Sizes S00 to S3:

Fully wired and tested, with electrical interlock, dead interval of up to 10 s on reversing (size S00 with electrical and mechanical interlocks)

Sizes S00 to S12:

As individual parts for customer assembly.

A dead interval of 50 ms on reversing is already integrated in the time relay function.

There is also a range of accessories (auxiliary switch blocks, surge suppressors, etc.) that must be ordered separately.

For overload relays for motor protection see "Protection Equipment --> Overload Relays --> 3RB2 Solid-State Overload Relays".

The 3RA14 contactor assemblies have screw terminals and are suitable for screwing or snapping onto 35 mm standard mounting rails.

Fully wired and tested 3RA14 contactor assemblies have one unassigned NO contact which is mounted onto the front of the K3 delta contactor.

A solid-state time-delay auxiliary switch block is snapped onto the front of the complete contactor assemblies, size S00 up to 7.5 kW, while a timing relay is mounted onto the side of sizes S0 to S3, 11 kW to 75 kW.

Rated data at AC 50 Hz 400 V			Size			Accessories for customer assembly		
Rating kW	Operational current I_e A	Motor current A		Line/delta contactor	Star contactor	Order No. complete	Timing relay	Assembly kit A, for double infeed
5.5	12	9.5 ... 13.8	S00-S00-S00	3RT10 15	3RT10 15	3RA14 15-8XB31-1...	3RT19 16-2G.51	--
7.5	17	12.1 ... 17		3RT10 17		3RA14 16-8XB31-1...	3RP15 74-1N.30	
11	25	19 ... 25	S0-S0-S0	3RT10 24	3RT10 24	3RA14 23-8XC21-1...	3RP15 74-1N.30	--
15	32	24.1 ... 34		3RT10 26		3RA14 25-8XC21-1...		
18.5	40	34.5 ... 40						
22	50	31 ... 43	S2-S2-S0	3RT10 34	3RT10 26	3RA14 34-8XC21-1...	3RP15 74-1N.30	3RA19 33-2C ³⁾
30	50	48.3 ... 65		3RT10 35		--		
37	80	62.1 ... 77.8	S2-S2-S2		3RT10 34	3RA14 35-8XC21-1...		3RA19 33-2B ³⁾
45	86	69 ... 86		3RT10 36		3RA14 36-8XC21-1...		
55	115	77.6 ... 108.6	S3-S3-S2	3RT10 44	3RT10 35	3RA14 44-8XC21-1...	3RP15 74-1N.30	3RA19 43-2C ³⁾
75	150	120.7 ... 150		3RT10 45	3RT10 36	3RA14 45-8XC21-1...		
90	160	86 ... 160	S6-S6-S3	3RT10 54	3RT10 44	--	3RP15 74-1N.30	--
110	195	86 ... 195						
132	230	86 ... 230			3RT10 55	3RT10 45		
160	280	86 ... 280		3RT10 56	3RT10 46			
200	350	95 ... 350	S10-S10-S6	3RT10 64	3RT10 54	--	3RP15 74-1N.30	--
250	430	95 ... 430		3RT10 65	3RT10 55			
315	540	277 ... 540	S12-S12-S10	3RT10 75	3RT10 64	--	3RP15 74-1N.30	--
355	610	277 ... 610						
400	690	277 ... 690				3RT10 65		
500	850	277 ... 850		3RT10 76	3RT10 66			

1) Assembly kit contains mechanical interlock, 3 connecting clips; wiring modules on the top (connection between line and delta contactor) and on the bottom (connection between delta and star contactor); star jumper.

2) Assembly kit contains 5 connecting clips; wiring modules on the top (connection between line and delta contactor) and on the bottom (connection between delta and star contactor); star jumper.

3) Assembly kit contains wiring module on the bottom (connection between delta and star contactor) and star jumper.

4) Wiring module on top from reversing contactor assembly (note conductor cross-sections).

3RA13, 3RA14 Contactor Assemblies

3RA14 Contactor Assemblies for Wye-Delta Starting

3RA14 complete units, 3 ... 75 kW

Components for customer assembly

Assembly kits with wiring modules and, if necessary, mechanical connectors are available for contactor assemblies for wye-delta starting. Contactors, overload relays, wye-delta timing relays, auxiliary switches for electrical interlock – if required also feeder terminals, mechanical interlocks (exception: In the case of the assembly kit for size S00 contactor assemblies the mechanical interlock between the delta contactor and the star contactor is included in the kit) and base plates – must be ordered separately.

The wiring kits for sizes S00 and S0 contain the top and bottom main conducting path connections between the line and delta contactors (top) and between the delta and star contactors (bottom).

In the case of sizes S2 to S12 only the bottom main conducting path connection between the delta and star contactors is included in the wiring module, owing to the larger conductor cross-section at the infeed.

Motor protection

Overload relays or thermistor motor protection tripping units can be used for overload protection.

The overload relay can be either mounted onto the line contactor or separately fitted. It must be set to 0.58 times the rated motor current.

Note:

The selection of contactor types refers to fused configurations (see table on page 3/88).

Assembly kit B, for single infeed	Star jumper	Base plates	Overload relay, thermal (CLASS 10 trip class)		Overload relay, solid-state (CLASS 10 trip class)	
			Setting range	Order No.	Setting range	Order No.
3RA19 13-2B ¹⁾	3RT19 16-4BA31	--	A 5.5 ... 8 7 ... 10	3RU11 16-1HB0 3RU11 16-1JB0	A 3 ... 12	3RB20 16-1SB0
3RA19 23-2B ²⁾	3RT19 26-4BA31	--	11 ... 16 14 ... 20 20 ... 25	3RU11 26-4AB0 3RU11 26-4BB0 3RU11 26-4DB0	6 ... 25	3RB20 26-1QB0
3RV19 35-1A	3RT19 26-4BA31	3RA19 32-2E	18 ... 25 28 ... 40	3RU11 36-4DB0 3RU11 36-4FB0	12.5 ... 50	3RB20 36-1UB0
	3RT19 36-4BA31	3RA19 32-2F	36 ... 45 40 ... 50	3RU11 36-4GB0 3RU11 36-4HB0		
--	3RT19 36-4BA31	3RA19 42-2E	45 ... 63 70 ... 90	3RU11 46-4JB0 3RU11 46-4LB0	25 ... 100	3RB20 46-1EB0
3RA19 53-3D ⁴⁾	3RT19 46-4BA31	3RA19 52-2E	--	--	50 ... 200	3RB20 56-1FW2
						3RB20 56-1FC2
--	3RT19 56-4BA31	3RA19 62-2E	--	--	55 ... 250	3RB20 66-1GC2
--	3RT19 66-4BA31	3RA19 72-2E	--	--	160 ... 630	3RB20 66-1MC2

For footnotes see page 3/86.

3RA13, 3RA14 Contactor Assemblies

3RA14 Contactor Assemblies for Wye-Delta Starting

3RA14 complete units, 3 ... 75 kW

Function

Wye-delta starting can only be used either if the motor normally operates in a Δ connection or starts softly or if the load torque during Y starting is low and does not increase sharply. On the Y step the motors can carry approximately 50 % (class KL 16) or 30 % (class KL 10) of their rated torque; The tightening torque is approximately 1/3 of that during direct on-line starting. The starting current is approximately 2 to 2.7 times the rated motor current.

The changeover from Y to Δ must not be effected until the motor has run up to rated speed. Operating mechanisms which require this changeover to be performed earlier are unsuitable for wye-delta starting.

The ratings given in the table are only applicable to motors with a starting current ratio $I_A \leq 8.4 \times I_N$ and using either a 3RT19 16-2G or 3RT19 26-2G solid-state time-delay auxiliary

switch block with a wye-delta function or a 3RP15 74. wye-delta timing relay with a dead interval on reversing of approximately 50 ms.

Surge suppression

Sizes S00 to S3:

All contactor assemblies can be fitted with RC elements, varistors or diode assemblies for damping opening surges in the coil.

As with the individual contactors, the surge suppressors can either be plugged onto the top of the contactors (S00) or fitted onto the coil terminals on the top or bottom (S0 to S3).

Sizes S6 to S12:

The contactors are fitted with varistors as standard.

Technical specifications

Short-circuit protection with fuses for motor feeders with short-circuit currents up to 50 kA and 690 V.
For overload relays see "Protection Equipment --> Overload Relays --> 3RB2 Solid-State Overload Relays".

Rating kW	Sizes of contactors K1-K3-K2	Rated motor current A	Overload relay Type	Setting range A (the overload relays must be set to 0.58 times the rated motor current)	Permissible back-up fuses for starters, comprising contactor assemblies and overload relays.					
					Single or double infeed ¹⁾ Fuse links LV HRC DIAZED NEOZED gL/gG operational class Type of coordination		LV HRC TYPE 3ND Operational class aM Type of coordination	@ listed fuses CLASS RK5/L	British Standard Fuses BS88 Type of coordination	
					"1" A	"2" A	"2" A	A	"1" A	"2" A
5.5	S00-S00-S00	12	3RU11 16-1HB0	5.5 ... 8	35	20	10	30	35	20
7.5	S00-S00-S00	16	3RU11 16-1JB0	7 ... 10	35	20	16	40	35	20
11	S0-S0-S0	22	3RU11 26-4AB0	11 ... 16	63	25	20	60	63	25
15	S0-S0-S0	29	3RU11 26-4BB0	14 ... 20	100	35	20	80	100	35
18.5	S0-S0-S0	35	3RU11 26-4DB0	20 ... 25	100	35	20	100	100	35
22	S2-S2-S0	41	3RU11 36-4EB0	22 ... 32	125	63	35	125	125	63
30	S2-S2-S0	55	3RU11 36-4FB0	28 ... 40	125	63	50	150	125	63
37	S2-S2-S2	66	3RU11 36-4GB0	36 ... 45	125	63	50	175	125	63
45	S2-S2-S2	80	3RU11 36-4HB0	40 ... 50	160	80	50	200	160	80
55	S3-S3-S2	97	3RU11 46-4KB0	57 ... 75	250	125	63	300	250	125
75	S3-S3-S2	132	3RU11 46-4LB0	70 ... 90	250	160	80	350	250	160
90	S6-S6-S3	160	3RB20 56-1FC2	50 ... 200	355	315	160	450	355	250
110	S6-S6-S3	195	3RB20 56-1FC2	50 ... 200	355	315	160	450	355	250
132	S6-S6-S3	230	3RB20 56-1FC2	50 ... 200	355	315	160	500	355	315
160	S6-S6-S3	280	3RB20 56-1FC2	50 ... 200	355	315	200	500	355	315
200	S10-S10-S6	350	3RB20 66-1GC2	55 ... 250	500	400	250 ²⁾	700	500	400
250	S10-S10-S6	430	3RB20 66-1MC2	160 ... 630	500	400 ²⁾	315 ²⁾	800	500	400
315	S12-S12-S10	540	3RB20 66-1MC2	160 ... 630	630	500 ²⁾	400 ²⁾	1000	630	450 ²⁾
355	S12-S12-S10	610	3RB20 66-1MC2	160 ... 630	630	500 ²⁾	400 ²⁾	1000	630	450 ²⁾
400	S12-S12-S10	690	3RB20 66-1MC2	160 ... 630	630 ²⁾	500 ²⁾	400 ²⁾	1000	630 ²⁾	450 ²⁾
500	S12-S12-S10	850	3RB20 66-1MC2	160 ... 630	630 ²⁾	500 ²⁾	500 ²⁾	1200	630 ²⁾	500 ²⁾

¹⁾ The maximum rated motor current must not be exceeded.

²⁾ Only double infeed with separately fused feeder lines for line and delta contactor is possible because the maximum possible fuse value lies far below the rated motor current.

3RA13, 3RA14 Contactor Assemblies

3RA14 Contactor Assemblies for Wye-Delta Starting

3RA14 complete units, 3 ... 75 kW

Starter	Sizes S..S..S.. Type 3RA.. ..		00-00-00 14 15	00-00-00 14 16	0-0-0 14 23	0-0-0 14 25	2-2-0 14 34	2-2-2 14 35	2-2-2 14 36	3-3-2 14 44	3-3-2 14 45
<i>All technical specifications not mentioned in the table below are identical to those of the individual 3RT contactors and 3RU overload relays</i>											
Mechanical endurance		Operating cycles	3 million								
Short-circuit protection without overload relay			1)								
Maximum rated current of the fuse											
Main circuit											
Fuse links, gL/gG											
LV HRC 3NA, DIAZED 5SB, NEOZED 5SE											
Single or double infeed											
acc. to IEC 60947-4-1/ EN 60947-4-1											
	• Type of coordination "1"	A	35	35	63	100	125	125	160	250	250
	• Type of coordination "2"	A	20	20	25	35	63	63	80	125	160
Control circuit											
Fuse links, gL/gG											
DIAZED 5SB, NEOZED 5SE											
(short-circuit current $I_k \leq 1$ kA)											
Miniature circuit breaker with C characteristic											
		A	10								
		A	6 ²⁾ , if the auxiliary contact of the overload relay is connected in the contactor coil circuit								
		A	10								
		A	6 ²⁾ , if the auxiliary contact of the overload relay is connected in the contactor coil circuit								
Size of individual contactors	• K1 line contactor • K3 delta contactor • K2 star contactor	Type 3RT Type 3RT Type 3RT	10 15 10 15 10 15	10 17 10 17 10 15	10 24 10 24 10 24	10 26 10 26 10 24	10 34 10 34 10 26	10 35 10 35 10 34	10 36 10 36 10 34	10 44 10 44 10 35	10 45 10 45 10 36
Unassigned auxiliary contacts of the individual contactors											
3)											
Current-carrying capacity with reversing time up to 10 s											
• Rated operational current I_e		At 400 V A 500 V A 690 V A	12 8.7 6.9	17 11.3 9	25 20.8 20.8	40 31.2 22.5	65 55.4 53.7	80 69.3 69.3	86 86 69.3	115 112.6 98.7	150 138.6 138.6
• Rated power for induction motors at 50 Hz and 60 Hz and		At 230 V kW 400 V kW 500 V kW 690 V kW 1000 V kW	3.3 5.8 5.3 5.8 --	4.7 8.2 6.9 7.5 --	7.2 12.5 13 18 --	12 21 20.5 20.4 --	20.4 35 38 51 --	25.5 44 48 66 --	27.8 48 60 67 --	37 65 80 97 --	49 85 98 136 --
• Switching frequency with overload relay		h^{-1}	15	15	15	15	15	15	15	15	15
Current-carrying capacity with reversing time up to 15 s											
• Rated operational current I_e		At 400 V A 500 V A 690 V A	12 8.7 6.9	17 11.3 9	25 20.8 20.8	31 28 22.5	44 39 44	57 51 57	67 67 67	97 97 97	106 106 106
• Rated power for induction motors at 50 Hz and 60 Hz and		At 230 V kW 400 V kW 500 V kW 690 V kW 1000 V kW	3.3 5.8 5.3 5.8 --	4.7 8.2 6.9 7.5 --	7.2 12.5 13 18 --	9.4 16.3 20.4 20.4 --	13.8 24 30 42 --	18.2 31.6 40 55 --	21.6 38 47 65 --	32 55 69 95 --	35 60 75 104 --
• Switching frequency with overload relay		h^{-1}	15	15	15	15	15	15	15	15	15
Current-carrying capacity with reversing time up to 20 s											
• Rated operational current I_e		At 400 V A 500 V A 690 V A	12 8.7 6.9	17 11.3 9	25 20.8 20.8	28 28 22.5	39 39 39	51 51 51	57 57 57	85 85 85	92 92 92
• Rated power for induction motors at 50 Hz and 60 Hz and		At 230 V kW 400 V kW 500 V kW 690 V kW 1000 V kW	3.3 5.8 5.3 5.8 --	4.7 8.2 6.9 7.5 --	7.2 12.5 13 18 --	8.5 14.7 18.4 20.4 --	12.2 21.3 26.7 37 --	16.3 28 35 49 --	18.4 32 40 55 --	28 48 60 83 --	30 52 65 90 --
• Switching frequency with overload relay		h^{-1}	15	15	15	15	15	15	15	15	15

1) For short-circuit protection with overload relays see "Protection Equipment --> Overload Relays --> 3RB2 Solid-State Overload Relays".

2) Up to $I_k < 0.5$ kA; ≤ 260 V.

3) For circuit diagrams of the control circuit see page 3/238.

3TD, 3TE Contactor Assemblies

3TD6 reversing contactor assemblies, 335 kW

Overview

The contactor assemblies are suitable for use in any climate and the contactors are mechanically interlocked. They are finger-safe according to EN 50274.

Complete units and components for customer assembly are available. For motor protection, either overload relays for stand-alone installation or thermistor motor protection tripping units must be ordered separately.

Complete units

3TD68 contactor assemblies each consist of two mechanically interlocked 3TF68 contactors. Electrical interlocking is wired. The main and control circuits are wired according to the schematics.

An internal circuit diagram, a type designation and an unit labeling plate are provided on a common cover.

Auxiliary contacts

The contactor assemblies each have 2 NO + 2 NC contacts per contactor. 1 NO + 1 NC contacts with momentary-contact operation and 2 NO + 1 NC contacts with continuous operation are unassigned.

Function

The operating times of the individual contactors are rated in such a way that no overlapping of the contact making and the arcing time between two contactors can occur on reversing, providing they are interlocked via their auxiliary switches and the operating mechanisms.

The operating times of the individual contactors are not affected by the mechanical interlock.

Technical specifications

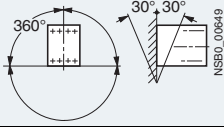
Contactors	Type	3TD68	
General data			
Permissible mounting position, installation instructions¹⁾			
The contactors are designed for operation on a vertical mounting surface.			
			
Ⓢ and Ⓜ ratings			
Rated insulation voltage	V AC	600	
Uninterrupted current enclosed	A	550	
Maximum horsepower ratings (Ⓢ and Ⓜ approved values)			
• Rated power for induction motors at 60 Hz	At 200 V	hp	200
	230 V	hp	229
	460 V	hp	464
	575 V	hp	582
NEMA/EEMAC ratings			
	NEMA/EEMAC SIZE	6	
• Uninterrupted current	- Open	A	600
	- Enclosed	A	540
• Rated power for induction motors with 60 Hz	At 200 V	hp	150
	230 V	hp	200
	460 V	hp	400
	575 V	hp	400
Overload relays	• Type	3RB20 66	
	• Setting range	A	160 ... 630

For short-circuit protection with overload relays see "Protection Equipment --> Overload Relays --> 3RB2 Solid-State Overload Relays".

The technical specifications are identical to those of the 3TF68 individual contactors.

The mechanical endurance is 5 million operating cycles for 3TD68.

For the unassigned auxiliary contacts of the individual contactors, see "Circuit Diagrams of the Control Circuits".

¹⁾ If the contactors are mounted at a 90° angle (conducting paths horizontally one above the other), the following reductions apply: switching frequency: to 80 % of the standard values.

3TE6 contactor assemblies for wye-delta starting,
630 kW

Overview

The contactor assemblies are suitable for use in any climate. They are finger-safe according to EN 50274.

3TE contactor assemblies are available as complete units and components for customer assembly.

The complete unit combinations are optionally supplied without a main conducting path connection between the line contactor and the delta contactor.

Motor protection

3TE68 contactor assemblies are supplied without overload protection. Overload relays or thermistor motor protection tripping units must be ordered separately.

The overload relay can be either mounted onto the line contactor or separately fitted. It must be set to 0.58 times the rated motor current.

Function

Wye-delta starting can only be used either if the motor normally operates in a Δ connection or starts softly or if the load torque during Y starting is low and does not increase sharply. On the Y step the motors can carry approximately 50 % (class KL 16) or 30 % (class KL 10) of their rated torque; The tightening torque is approximately 1/3 of that during direct on-line starting. The starting current is approximately 2 to 2.7 times the rated motor current.

The changeover from Y to Δ must not be effected until the motor has run up to rated speed. Operating mechanisms which require this changeover to be performed earlier are unsuitable for wye-delta starting.

The ratings given in the selection table are only applicable to motors with a starting current ratio of $I_A \leq 8.4 \times I_N$ and using a 3RP15 74 wye-delta timing relay with a dead interval of approximately 50 ms on reversing.

Technical specifications

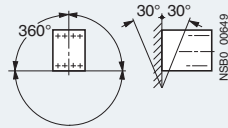
Starter	Type	3TE68		
General data				
Permissible mounting position, installation instructions¹⁾				
The contactors are designed for operation on a vertical mounting surface.				
				
Mechanical endurance	Operating cycles	3 million		
Type of individual contactors	• K1 line contactor • K3 delta contactor • K2 star contactor	Type	3TF68 3TF68 3RT10 75	
Unassigned auxiliary contacts of the individual contactors				
2)				
Current-carrying capacity with reversing time up to 10 s				
• Rated operational current I_e	Up to 690 V	A	1090	
• Rated power for induction motors at 50 Hz	At 230 V	kW	355	
	400 V	kW	612	
	500 V	kW	800	
	690 V	kW	1046	
• Switching frequency with overload relay		h^{-1}	3	
Current-carrying capacity with reversing time up to 15 s				
• Rated operational current I_e	Up to 500 V	A	923	
	690 V	A	883	
• Rated power for induction motors at 50 Hz	At 230 V	kW	295	
	400 V	kW	515	
	500 V	kW	677	
	690 V	kW	885	
• Switching frequency with overload relay		h^{-1}	2	
Current-carrying capacity with reversing time up to 20 s				
• Rated operational current I_e	Up to 500 V	A	800	
	690 V	A	765	
• Rated power for induction motors at 50 Hz	At 230 V	kW	244	
	400 V	kW	444	
	500 V	kW	590	
	690 V	kW	770	
• Switching frequency with overload relay		h^{-1}	2	
Short-circuit protection				
Main circuit				
Fuse links, gL/gG				
LV HRC 3NA, DIAZED 5SB, NEOZED 5SE				
Acc. to IEC 60947-4-1/ EN 60947-4-1	• Type of coordination "1"	A	1000	
	• Type of coordination "2"	A	500 ³⁾	
Auxiliary circuit				
• Fuse links gL/gG (weld-free protection at $I_k \geq 1$ kA) DIAZED 5SB, NEOZED 5SE		A	10	
• Or miniature circuit breakers with C characteristic ($I_k < 400$ A)				

¹⁾ If the contactors are mounted at a 90° angle (conducting paths horizontally one above the other), the following reductions apply: switching frequency: to 80 % of the standard values.

²⁾ See "Circuit diagrams of the control circuits".

³⁾ The maximum rated motor current must not be exceeded.

3TD, 3TE Contactor Assemblies

3TE6 contactor assemblies for wye-delta starting, 630 kW

Contactor assembly	Type	3TE68
Short-circuit protection with fuses for motor feeders with short-circuit currents up to 50 kA and 690 V		
Rated motor current	A	277 ... 1090
Overload relays	Type	3RB20 66
Setting range (the overload relays must be set to 0.58 times the rated motor current)	A	160 ... 630
Permissible back-up fuses for starters, comprising contactor assemblies and overload relays. Single or double infeed ¹⁾		
<ul style="list-style-type: none"> • Fuse links LV HRC Type 3NA, DIAZED Type 5SB, NEOZED Type 5SE <ul style="list-style-type: none"> - Type of coordination "1" - Type of coordination "2" • Fuse links LV HRC type 3ND, aM operational class <ul style="list-style-type: none"> - Type of coordination "2" • Fuse links, Siemens Canada, HRC fuses, Type II • Fuse links UL-listed fuses CLASS L • Fuse links British Standard Fuses BS88 <ul style="list-style-type: none"> - Type of coordination "1" - Type of coordination "2" 	A A A A A A A	1000 500 630 1000 1200 1000 500

For short-circuit protection with overload relays see "Protection Equipment --> Overload Relays --> 3RB2 Solid-State Overload Relays".

Use double infeed for higher rated motor currents (see "Circuit diagram").

¹⁾ The maximum rated motor current must not be exceeded.

3RT, 3RH, 3TB, 3TC, 3TH, 3TK Contactors for Special Applications

3RT14 Contactors for Switching Resistive Loads (AC-1)

3-pole, 140 ... 690 A

Overview

AC and DC operation (size S3)

UC operation (AC/DC) (sizes S6 to S12)

IEC 60947, EN 60947 (VDE 0660)



The contactors are suitable for use in any climate. They are finger-safe according to EN 50274.

3RT14 contactors are used for switching resistive loads (AC-1) or as contactors, for example, for variable-speed operating mechanisms that normally only have to carry the current.

The accessories for the 3RT10 contactors can also be used here.

For more detailed descriptions about the sizes S6 to S12, see "3RT10 Contactors, 3-pole, 3 ... 250 kW".

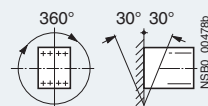
Technical specifications

Contactor	Type Size	3RT14 46 S3	
General data			
Permissible mounting position The contactors are designed for operation on a vertical mounting surface.	• AC and DC operation	 <p>For DC operation and 22.5 °C inclination towards the front, operating range 0.85 ... 1.1 x U_g</p>	
Upright mounting position:	• AC operation	 <p>Special version required.</p>	
	• DC operation	--	
Mechanical endurance	Operating cycles	10 million	
Electrical endurance in operating cycles Utilization category AC-1 at I_e	Operating cycles	0.5 million	
Rated insulation voltage U_i (degree of pollution 3)	V	1000	
Rated impulse withstand voltage U_{imp}	kV	6	
Protective separation between the coil and the main contacts acc. to EN 60947-1, Appendix N	V	690	
Mirror contacts • A mirror contact is an auxiliary NC contact that cannot be closed simultaneously with a NO main contact.	- Removable auxiliary switch block - Permanently fitted auxiliary switch block	Yes, acc. to EN 60947-4-1, Appendix F Acc. to Swiss regulations (SUVA) on request	
Permissible ambient temperature	• During operation • During storage	°C °C	-25 ... +60 -55 ... +80
Degree of protection acc. to EN 60947-1, Appendix C		IP20 (terminal compartment IP00), AC coil assembly IP40, DC coil assembly IP30	
Touch protection acc. to EN 50274		Finger-safe	
Shock resistance			
• Rectangular pulse	AC and DC operation	g/ms	6.8/5 and 4/10
• Sine pulse	AC and DC operation	g/ms	10.6/5 and 6.2/10
Conductor cross-sections			1)
Short-circuit protection for contactors without overload relays			
Main circuit Fuse links, gL/gG operational class, LV HRC, 3NA	• Type of coordination "1":	A	250
Fuse links, gR operational class, SITOR 3NE	• Type of coordination "2"	A	250
Auxiliary circuit			
• Fuse links gL/gG (weld-free protection at $I_k \geq 1$ kA) DIAZED 5SB, NEOZED 5SE		A	10
• Or miniature circuit breakers with C characteristic ($I_k < 400$ A)		A	10

1) For conductor cross-sections see page 3/96.

3RT, 3RH, 3TB, 3TC, 3TH, 3TK Contactors for Special Applications

3RT14 Contactors for Switching Resistive Loads (AC-1)

3-pole, 140 ... 690 A

Contactor	Type Size	3RT14 46 S3	
Control			
Magnetic coil operating range		AC/DC	0.8 ... 1.1 x U_s
Power consumption of the magnetic coils (when coil is cold and $1.0 \times U_s$)			
Standard version:			
• AC operation, 50 Hz	Closing	VA	270
	P.f.		0.68
• AC operation, 50/60 Hz	Closed	VA	22
	P.f.		0.27
	Closing	VA	298/274
	P.f.		0.7/0.62
For USA and Canada: • AC operation, 50 Hz	Closed	VA	27/20
	P.f.		0.29/0.31
	Closing	VA	270
	P.f.		0.68
• AC operation, 60 Hz	Closed	VA	22
	P.f.		0.27
	Closing	VA	300
	P.f.		0.52
• DC operation	Closing	VA	21
	P.f.		0.29
• DC operation	Closing = Closed	W	15
Operating times for 0.8 ... 1.1 x U_s ¹⁾			
Total break time = Opening delay + Arcing time			
• AC operation	- Closing delay	ms	17 ... 90
	- Opening delay	ms	10 ... 25
• DC operation	- Closing delay	ms	90 ... 230
	- Opening delay	ms	14 ... 20
• Arcing time		ms	10 ... 15
Operating times for 1.0 x U_s ¹⁾			
• AC operation	- Closing delay	ms	18 ... 30
	- Opening delay	ms	11 ... 23
• DC operation	- Closing delay	ms	100 ... 120
	- Opening delay	ms	16 ... 20

¹⁾ The OFF-delay of the NO contact and the ON-delay of the NC contact are increased if the contactor coils are attenuated against voltage peaks (varistor +2 ms to 5 ms, diode assembly: 2 to 6 times).

3RT, 3RH, 3TB, 3TC, 3TH, 3TK Contactors for Special Applications

3RT14 Contactors for Switching Resistive Loads (AC-1)





3-pole, 140 ... 690 A

Contactors	Type Size	3RT14 46 S3	
Main circuit			
AC capacity			
Utilization category AC-1, switching resistive loads			
• Rated operational currents I_e	At 40 °C up to 690 V	A	140
	At 60 °C up to 690 V	A	130
	At 1000 V	A	60
• Ratings of AC loads P.f. = 0.95 (at 60 °C)	At 230 V	kW	50
	400 V	kW	86
	500 V	kW	107
	690 V	kW	148
	1000 V	kW	98
• Minimum conductor cross-section for loads with I_e	At 40 °C	mm ²	50
	At 60 °C	mm ²	50
Utilization category AC-2 and AC-3			
With an electrical endurance of 1.3 million operating cycles			
• Rated operational current I_e	Up to 690 V	A	44
• Rated power of slipping or squirrel-cage motors at 50 Hz and 60 Hz (at 60 °C)	At 230 V	kW	12.7
	400 V	kW	22
	500 V	kW	29.9
	690 V	kW	38.2
Power loss per conducting path	At I_e /AC-1	W	12.5
Load rating with DC			
Utilization category DC-1, switching resistive loads (L/R ≤ 1 ms)			
• Rated operational currents I_e (at 60 °C)			
- 1 conducting path	Up to 24 V	A	130
	60 V	A	80
	110 V	A	12
	220 V	A	2.5
	440 V	A	0.8
	600 V	A	0.48
- 2 conducting paths in series	Up to 24 V	A	130
	60 V	A	130
	110 V	A	130
	220 V	A	13
	440 V	A	2.4
	600 V	A	1.3
- 3 conducting paths in series	Up to 24 V	A	130
	60 V	A	130
	110 V	A	130
	220 V	A	130
	440 V	A	6
	600 V	A	3.4
Utilization category DC-3/DC-5			
Shunt-wound and series-wound motors (L/R ≤ 15 ms)			
• Rated operational currents I_e (at 60 °C)			
- 1 conducting path	Up to 24 V	A	6
	60 V	A	3
	110 V	A	1.25
	220 V	A	0.35
	440 V	A	0.15
	600 V	A	0.1
- 2 conducting paths in series	Up to 24 V	A	130
	60 V	A	130
	110 V	A	130
	220 V	A	1.75
	440 V	A	0.42
	600 V	A	0.27
- 3 conducting paths in series	Up to 24 V	A	130
	60 V	A	130
	110 V	A	130
	220 V	A	4
	440 V	A	0.8
	600 V	A	0.45
Switching frequency			
Switching frequency z in operating cycles/hour			
• Contactors without overload relays	No-load switching frequency AC	1/h	5000
	No-load switching frequency DC	1/h	1000
• Rated operation	Acc. to AC-1 (AC/DC)	1/h	650
	Acc. to AC-3 (AC/DC)	1/h	1000
Dependence of the switching frequency z' on the operational current I' and operational voltage U' : $z' = z \cdot (I_e/I') \cdot (400 V/U')^{1.5} \cdot 1/h$.			

3RT, 3RH, 3TB, 3TC, 3TH, 3TK Contactors for Special Applications

3RT14 Contactors for Switching Resistive Loads (AC-1)

3-pole, 140 ... 690 A

Contactor	Type Size	3RT14 46 S3	
Conductor cross-sections			
(1 or 2 conductors can be connected) Front clamping point connected 	Main conductors: <u>With box terminal</u>		 Screw terminals
	<ul style="list-style-type: none"> • Finely stranded with end sleeve • Finely stranded without end sleeve • Solid • Stranded • Ribbon cable conductors (number x width x thickness) • AWG cables, solid or stranded 	mm ² 2.5 ... 50 mm ² 4 ... 50 mm ² 2.5 ... 16 mm ² 4 ... 70 mm 6 x 9 x 0.8 AWG 10 ... 2/0	
Rear clamping point connected 	<ul style="list-style-type: none"> • Finely stranded with end sleeve • Finely stranded without end sleeve • Solid • Stranded • Ribbon cable conductors (number x width x thickness) • AWG cables, solid or stranded 		mm ² 2.5 ... 50 mm ² 10 ... 50 mm ² 2.5 ... 16 mm ² 10 ... 70 mm 6 x 9 x 0.8 AWG 10 ... 2/0
	<ul style="list-style-type: none"> • Finely stranded with end sleeve • Finely stranded without end sleeve • Solid • Stranded • Ribbon cable conductors (number x width x thickness) • AWG cables, solid or stranded • Terminal screws - Tightening torque 		mm ² max. 2 x 35 mm ² max. 2 x 35 mm ² max. 2 x 16 mm ² max. 2 x 50 mm 2 x (6 x 9 x 0.8) AWG 2 x (10 ... 1/0) Nm M6 (hex. socket, A/F 4) 4 ... 6 (36 ... 53 lb.in)
Both clamping points connected 	<ul style="list-style-type: none"> • Finely stranded with end sleeve • Finely stranded without end sleeve • Solid • Stranded • Ribbon cable conductors (number x width x thickness) • AWG cables, solid or stranded • Terminal screws - Tightening torque 		mm ² max. 2 x 35 mm ² max. 2 x 35 mm ² max. 2 x 16 mm ² max. 2 x 50 mm 2 x (6 x 9 x 0.8) AWG 2 x (10 ... 1/0) Nm M6 (hex. socket, A/F 4) 4 ... 6 (36 ... 53 lb.in)
Connection for drilled copper bars	Max. width ¹⁾	mm	10
		Main conductors: <u>Without box terminal with cable lugs²⁾</u>	
<ul style="list-style-type: none"> • Finely stranded with cable lug • Stranded with cable lug • AWG cables, solid or stranded 		mm ² 10 ... 50 ³⁾ mm ² 10 ... 70 ³⁾ AWG 7 ... 1/0	
		Auxiliary conductors:	
<ul style="list-style-type: none"> • Solid • Finely stranded with end sleeve • AWG cables, solid or stranded • Terminal screws - Tightening torque 		mm ² 2 x (0.5 ... 1.5) 2 x (0.75 ... 2.5) acc. to IEC 60947; max. 2 x (0.75 ... 4) mm ² 2 x (0.5 ... 1.5) 2 x (0.75 ... 2.5) AWG 2 x (20 ... 16) 2 x (18 ... 14) 1 x 12 Nm M3 0.8 ... 1.2 (7 ... 10.3 lb.in)	

¹⁾ If bars larger than 12 x 10 mm are connected, a 3RT19 46-4EA1 terminal cover is needed to comply with the phase clearance.

²⁾ When connecting rails which are larger than 25 mm², the 3RT19 46-4EA1 terminal cover must be used to keep the phase clearance.

³⁾ Only with crimped cable lugs according to DIN 46234.
Cable lug max. 20 mm wide.

3RT, 3RH, 3TB, 3TC, 3TH, 3TK Contactors for Special Applications

3RT14 Contactors for Switching Resistive Loads (AC-1)

3-pole, 140 ... 690 A

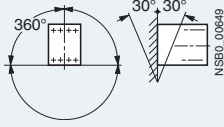
Contactors	Type Size	3RT14 56 S6	3RT14 66 S10	3RT14 76 S12	
General data					
Permissible mounting position The contactors are designed for operation on a vertical mounting surface.					
Mechanical endurance	Operating cycles	10 million			
Electrical endurance Utilization category AC-1 at I_e	Operating cycles	0.5 million			
Rated insulation voltage U_i (degree of pollution 3)	V	1000			
Rated impulse withstand voltage U_{imp}	kV	8			
Protective separation between the coil and the auxiliary contacts and main contacts acc. to EN 60947-1, Appendix N	V	690			
Mirror contacts A mirror contact is an auxiliary NC contact that cannot be closed simultaneously with a NO main contact.		Yes, acc. to EN 60947-4-1, Appendix F			
Permissible ambient temperature	<ul style="list-style-type: none"> • During operation • During storage 	°C	-25 ... +60/+55 with AS-Interface		
		°C	-55 ... +80		
Degree of protection acc. to EN 60947-1, Appendix C			IP00/open, coil assembly IP20		
Touch protection acc. to EN 50274			Finger-safe with cover		
Shock resistance	<ul style="list-style-type: none"> • Rectangular pulse • Sine pulse 	g/ms g/ms	8.5/5 and 4.2/10 13.4/5 and 6.5/10		
Conductor cross-sections			1)		
Electromagnetic compatibility (EMC)			2)		
Short-circuit protection					
Main circuit					
Fuse links gL/gG	• Type of coordination *1*:	A	355	500	800
LV HRC 3NA					
Fuse links gR, SITOR 3NE	• Type of coordination *2*:	A	350	500	710
Auxiliary circuit					
• Fuse links gL/gG (weld-free protection at $I_k \geq 1$ kA) DIAZED 5SB, NEOZED 5SE		A	10		
• Or miniature circuit breakers with C characteristic (short-circuit current $I_k < 400$ A)					

1) For conductor cross-sections see pages 3/100, 3/101.

2) For electromagnetic compatibility (EMC) see page 3/12.

3RT, 3RH, 3TB, 3TC, 3TH, 3TK Contactors for Special Applications

3RT14 Contactors for Switching Resistive Loads (AC-1)

3-pole, 140 ... 690 A

Contactors	Type Size		3RT14 56 S6	3RT14 66 S10	3RT14 76 S12	
Control						
Operating range of the solenoid	AC/DC (UC)		0.8 x $U_{s \min}$... 1.1 x $U_{s \max}$			
Power consumption of the solenoid (when coil is cool and rated range $U_{s \min}$... $U_{s \max}$)						
• Conventional operating mechanism						
- AC operation	Closing at $U_{s \min}$	VA/p.f.	250/0.9	490/0.9	700/0.9	
	Closing at $U_{s \max}$	VA/p.f.	300/0.9	590/0.9	830/0.9	
	Closed at $U_{s \min}$	VA/p.f.	4.8/0.8	5.6/0.9	7.6/0.9	
	Closed at $U_{s \max}$	VA/p.f.	5.8/0.8	6.7/0.9	9.2/0.9	
- DC operation	Closing at $U_{s \min}$	W	300	540	770	
	Closing at $U_{s \max}$	W	360	650	920	
	Closed at $U_{s \min}$	W	4.3	6.1	8.5	
	Closed at $U_{s \max}$	W	5.2	7.4	10	
• Solid-state operating mechanism						
- AC operation	Closing at $U_{s \min}$	VA/p.f.	190/0.8	400/0.8	560/0.8	
	Closing at $U_{s \max}$	VA/p.f.	28/0.8	530/0.8	750/0.8	
	Closed at $U_{s \min}$	VA/p.f.	3.5/0.5	4/0.5	5.4/0.8	
	Closed at $U_{s \max}$	VA/p.f.	4/0.4	5/0.4	7/0.8	
- DC operation	Closing at $U_{s \min}$	W	250	440	600	
	Closing at $U_{s \max}$	W	320	580	800	
	Closed at $U_{s \min}$	W	2.3	3.2	4	
	Closed at $U_{s \max}$	W	2.8	3.8	5	
PLC control input (EN 61131-2/type 2)			24 V DC/≤ 30 mA power consumption, (operating range 17 ... 30 V DC)			
Operating times (Total break time = Opening delay + Arcing time)						
• Conventional operating mechanism						
- With 0.8 x $U_{s \min}$... 1.1 x $U_{s \max}$	Closing delay	ms	20 ... 95	30 ... 95	45 ... 100	
	Opening delay	ms	40 ... 60	40 ... 80	60 ... 100	
- For $U_{s \min}$... $U_{s \max}$	Closing delay	ms	25 ... 50	35 ... 50	50 ... 70	
	Opening delay	ms	40 ... 60	50 ... 80	70 ... 100	
• Solid-state operating mechanism, actuated via A1/A2						
- With 0.8 x $U_{s \min}$... 1.1 x $U_{s \max}$	Closing delay	ms	95 ... 135	105 ... 145	120 ... 150	
	Opening delay	ms	80 ... 90	80 ... 200	80 ... 100	
- For $U_{s \min}$... $U_{s \max}$	Closing delay	ms	100 ... 120	110 ... 130	125 ... 150	
	Opening delay	ms	80 ... 90	80 ... 100	80 ... 100	
• Solid-state operating mechanism, actuated via PLC input						
- With 0.8 x $U_{s \min}$... 1.1 x $U_{s \max}$	Closing delay	ms	35 ... 75	45 ... 80	60 ... 90	
	Opening delay	ms	80 ... 90	80 ... 100	80 ... 100	
- For $U_{s \min}$... $U_{s \max}$	Closing delay	ms	40 ... 60	50 ... 65	65 ... 80	
	Opening delay	ms	80 ... 90	80 ... 100	80 ... 100	
• Arcing time						
		ms	10 ... 15	10 ... 15	10 ... 15	
Main circuits						
AC capacity						
Utilization category AC-1, switching resistive loads						
• Rated operational currents I_e	At 40 °C up to 690 V A		275	400	690	
	At 60 °C up to 690 V A		250	380	650 ¹⁾	
• Rated power for AC loads ²⁾ P.f. = 0.95 (at 60 °C)	At 1000 V A		100	150	250	
	At 230 V kW		95	145	245	
	400 V kW		165	250	430	
	500 V kW		205	315	535	
	690 V kW		285	430	740	
	1000 V kW		165	247	410	
• Minimum conductor cross-section for loads with I_e	At 40 °C mm ²		2 x 70	240	2 x 240	
	At 60 °C mm ²		120	240	2 x 240	
Power loss per conducting path			At I_e /AC-1 W	20	27	55
Utilization category AC-2 and AC-3 for an electrical endurance of 1.3 million operating cycles						
• Rated operational current I_e	Up to 690 V A		97	138	170	
• Rated power of slipping or squirrel-cage motors at 50 Hz and 60 Hz (at 60 °C)	At 230 V kW		30	37	55	
	400 V kW		55	75	90	
	500 V kW		55	90	110	
	690 V kW		90	132	160	

1) 600 A for 3RT14 76-N contactor.

2) Industrial furnaces and electric heaters with resistance heating, etc.
(increased power consumption on heating up taken into account).

3RT, 3RH, 3TB, 3TC, 3TH, 3TK Contactors for Special Applications

3RT14 Contactors for Switching Resistive Loads (AC-1)

3-pole, 140 ... 690 A

Contactors	Type Size		3RT14 56 S6	3RT14 66 S10	3RT14 76 S12
Main circuit					
<i>Load rating with DC</i>					
Utilization category DC-1, switching resistive loads ($L/R \leq 1$ ms)					
• Rated operational currents I_e (at 60 °C)					
- 1 conducting path		Up to 24 V A	250	380	500
		60 V A	250	380	500
		110 V A	18	33	33
		220 V A	3.4	3.8	3.8
		440 V A	0.8	0.9	0.9
		600 V A	0.5	0.6	0.6
- 2 conducting paths in series		Up to 24 V A	250	380	500
		60 V A	250	380	500
		110 V A	250	380	500
		220 V A	20	380	500
		440 V A	3.2	4	4
		600 V A	1.6	2	2
- 3 conducting paths in series		Up to 24 V A	250	380	500
		60 V A	250	380	500
		110 V A	250	380	500
		220 V A	250	380	500
		440 V A	11.5	11	11
		600 V A	4	5.2	5.2
Utilization category DC-3/DC-5					
Shunt-wound and series-wound motors ($L/R \leq 15$ ms)					
• Rated operational currents I_e (at 60 °C)					
- 1 conducting path		Up to 24 V A	250	380	500
		60 V A	7.5	11	11
		110 V A	2.5	3	3
		220 V A	0.6	0.6	0.6
		440 V A	0.17	0.18	0.18
		600 V A	0.12	0.125	0.125
- 2 conducting paths in series		Up to 24 V A	250	380	500
		60 V A	250	380	500
		110 V A	250	380	500
		220 V A	2.5	2.5	2.5
		440 V A	0.65	0.65	0.65
		600 V A	0.37	0.37	0.37
- 3 conducting paths in series		Up to 24 V A	250	380	500
		60 V A	250	380	500
		110 V A	250	380	500
		220 V A	250	380	500
		440 V A	1.4	1.4	1.4
		600 V A	0.75	0.75	0.75

Switching frequency**Switching frequency z** in operating cycles/hour

• Contactors without overload relays	No-load switching frequency	h ⁻¹	2000
		AC-1 h ⁻¹	600
		AC-3 h ⁻¹	1000





Dependence of the switching frequency z' on the operational current I' and operational voltage U' :

$$z' = z \cdot (I_e/I') \cdot (400 V/U')^{1.5} \cdot 1/h$$

3RT, 3RH, 3TB, 3TC, 3TH, 3TK Contactors for Special Applications

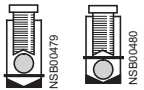
3RT14 Contactors for Switching Resistive Loads (AC-1)

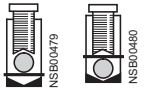
3-pole, 140 ... 690 A

Contactor	Type Size	3RT14 56 S6	
Conductor cross-sections			
Front or rear clamping point connected 	Main conductors: With 3RT19 55-4G box terminal <ul style="list-style-type: none"> Finely stranded with end sleeve Finely stranded without end sleeve Stranded Ribbon cable conductors (number x width x thickness) AWG cables, solid or stranded 	mm ² 16 ... 70 mm ² 16 ... 70 mm ² 16 ... 70 mm 3 x 9 x 0.8 ... 6 x 15.5 x 0.8 AWG 6 ... 2/0	 Screw terminals
Front or rear clamping point connected 	Main conductor With 3RT19 56-4G box terminal <ul style="list-style-type: none"> Finely stranded with end sleeve Finely stranded without end sleeve Stranded Ribbon cable conductors (number x width x thickness) AWG cables, solid or stranded 	mm ² 16 ... 120 mm ² 16 ... 120 mm ² 16 ... 120 mm 3 x 9 x 0.8 ... 10 x 15.5 x 0.8 AWG 6 ... 250 kcmil	 Screw terminals
Main conductors: Without box terminal/busbar connection ¹⁾ <ul style="list-style-type: none"> Finely stranded with cable lug Stranded with cable lug AWG cables, solid or stranded Connecting bar (max. width) Terminal screw <ul style="list-style-type: none"> Tightening torque 		16 ... 95 25 ... 120 4 ... 250 kcmil 17 M8 x 25 (A/F 13) 10 ... 14 (90 ... 110) lb.in	
Auxiliary conductors: <ul style="list-style-type: none"> Conductor cross-section <ul style="list-style-type: none"> Solid Finely stranded with end sleeve Solid or stranded AWG (2 x) Terminal screw <ul style="list-style-type: none"> Tightening torque 		2 x (0.5 ... 1.5) ² ; 2 x (0.75 ... 2.5) ² acc. to IEC 60947; max. 2 x (0.75 ... 4) 2 x (0.5 ... 1.5) ² ; 2 x (0.75 ... 2.5) ² 2 x (18 ... 14) M3 (PZ 2) 0.8 ... 1.2 (7 ... 10.3) lb.in	



¹⁾ When connecting cable lugs according to DIN 46235, use the 3RT19 56-4EA1 terminal cover for conductor cross-sections from 95 mm² to ensure phase spacing.

²⁾ If two different conductor cross-sections are connected to one clamping point, both cross-sections must lie in the range specified. If identical cross-sections are used, this restriction does not apply.

3RT, 3RH, 3TB, 3TC, 3TH, 3TK Contactors for Special Applications

3RT14 Contactors for Switching Resistive Loads (AC-1)

3-pole, 140 ... 690 A

Contactors	Type Size	3RT14 66 S10	3RT14 76 S12
Conductor cross-sections			
(1 or 2 conductors can be connected)	Main conductors: <u>With 3RT19 66-4G box terminal</u>	⊕ Screw terminals	
Front clamping point connected  NSB00479	<ul style="list-style-type: none"> • Finely stranded with end sleeve • Finely stranded without end sleeve • Stranded • AWG cables, solid or stranded • Ribbon cable conductors (number x width x thickness) 	mm ² 70 ... 240 mm ² 70 ... 240 mm ² 95 ... 300 AWG 3/0 ... 600 kcmil mm Min. 6 x 9 x 0.8, max. 20 x 24 x 0.5	
Rear clamping point connected  NSB00480	<ul style="list-style-type: none"> • Finely stranded with end sleeve • Finely stranded without end sleeve • Stranded • AWG cables, solid or stranded • Ribbon cable conductors (number x width x thickness) 	mm ² 120 ... 185 mm ² 120 ... 185 mm ² 120 ... 240 AWG 250 ... 500 kcmil mm Min. 6 x 9 x 0.8, max. 20 x 24 x 0.5	
Both clamping points connected  NSB00481	<ul style="list-style-type: none"> • Finely stranded with end sleeve • Finely stranded without end sleeve • Stranded • AWG cables, solid or stranded • Ribbon cable conductors (number x width x thickness) • Terminal screws - Tightening torque 	mm ² Min. 2 x 50, max. 2 x 185 mm ² Min. 2 x 50, max. 2 x 185 mm ² Min. 2 x 70, max. 2 x 240 AWG Min. 2 x 2/0, max. 2 x 500 kcmil mm Max. 2 x (20 x 24 x 0.5) Nm M12 (hexagon socket, A/F 5) 20 ... 22 (180 ... 195 lb.in)	
	Main conductors: <u>Without box terminal/busbar connection¹⁾</u>		
	<ul style="list-style-type: none"> • Finely stranded with cable lug • Stranded with cable lug • AWG cables, solid or stranded • Connecting bar (max. width) • Terminal screws - Tightening torque 	mm ² 50 ... 240 mm ² 70 ... 240 AWG 2/0 ... 500 kcmil mm 25 Nm M10 x 30 (A/F 17) 14 ... 24 (124 ... 210 lb.in)	
	Auxiliary conductors:		
	<ul style="list-style-type: none"> • Solid • Finely stranded with end sleeve • AWG cables, solid or stranded • Terminal screws - Tightening torque 	mm ² 2 x (0.5 ... 1.5) ²⁾ , 2 x (0.75 ... 2.5) ²⁾ acc. to IEC 60947, max. 2 x (0.75 ... 4) mm ² 2 x (0.5 ... 1.5) ²⁾ ; 2 x (0.75 ... 2.5) ²⁾ AWG 2 x (18 ... 14) Nm M3 (PZ 3) 0.8 ... 1.2 (7 ... 10.3 lb.in)	

¹⁾ When connecting cable lugs to DIN 46234, the 3RT19 66-4EA1 terminal cover must be used for conductor cross-sections of 240 mm² and more as well as DIN 46235 for conductor cross-sections of 185 mm² and more to keep the phase clearance.

²⁾ If two different conductor cross-sections are connected to one clamping point, both cross-sections must lie in the range specified. If identical cross-sections are used, this restriction does not apply.

3RT, 3RH, 3TB, 3TC, 3TH, 3TK Contactors for Special Applications

3RT13 Contactors for Switching Resistive Loads (AC-1)

4-pole, 4 NO, 18 ... 140 A

Overview

AC and DC operation

EN 60947-4-1 (VDE 0660 Part 102).

The contactors are suitable for use in any climate. They are finger-safe according to EN 50274.

The accessories for the 3-pole SIRIUS contactors can also be used for the 4-pole versions.

Function

- Switching resistive loads
- Isolating systems with ungrounded or poorly grounded neutral conductors
- System transfers when alternative AC power supplies are used
- As contactors, e. g. for variable-speed operating mechanisms which only have to carry current and not switch
- The contactors are also suitable for switching mixed loads in distribution systems (e. g. for supplying heaters, lamps, motors, PC power supply units) with p.f. > 0.8 according to IEC 60947-4-1 test conditions for utilization category AC-1.

Integration

Mountable auxiliary contacts

Size S00

4 auxiliary contacts (according to EN 50005)

Size S0

Maximum 2 auxiliary contacts (either laterally mounted or snapped onto the top).

Size S2 to S3

Max. 4 auxiliary contacts (either laterally mounted or snapped onto the top)

Contactor assembly with mechanical interlock

The 4-pole 3RT13 contactors with 4 NO contacts as the main contacts are suitable for making contactor assemblies with a mechanical interlock, e. g. for system transfers.

Size S00

Contactor assemblies can be constructed from two 3RT13 1. contactors in conjunction with mechanical interlocks and two connecting clips (Order No.: 3RA19 12-2H, pack with 10 interlock elements and 20 clips for 10 assemblies).

Size S0

When constructing 4-pole contactor assemblies from two 3RT13 2. contactors, the fourth pole of the left contactor must always be moved to the left side. The contactor assembly can then be made easily with the aid of the 3RA19 24-1A mechanical interlock fitted onto the front and the 3RA19 22-2C mechanical connectors. The laterally mountable 3RA19 24-2B mechanical interlock can be used if the contactor assembly is mounted on a base plate.

Sizes S2 and S3

Contactor assemblies can be constructed from two 3RT13 3. or two 3RT13 4. contactors in conjunction with the laterally mountable 3RA19 24-2B mechanical interlock and the 3RA19 .2-2G mechanical connectors. The mechanical interlock for fitting onto the front cannot be used for size S2 and S3 contactors.

3RT, 3RH, 3TB, 3TC, 3TH, 3TK Contactors for Special Applications

3RT13 Contactors for Switching Resistive Loads (AC-1)

4-pole, 4 NO, 18 ... 140 A

Technical specifications

Contactors	Type Size		3RT13 16 S00	3RT13 17	3RT13 25 S0	3RT13 26	3RT13 36 S2	3RT13 44 S3	3RT13 46 S3	
General data										
Permissible mounting position¹⁾										
Mechanical endurance		Operating cycles	30 million	10 million						
Electrical endurance at $I_e/AC-1$		Operating cycles	Approx. 0.5 million							
Rated insulation voltage U_i (degree of pollution 3)		V	690							
Permissible ambient temperature		• During operation • During storage	°C	-25 ... +60 -55 ... +80						
Degree of protection Acc. to EN 60947-1, Appendix C		Device Connection range	IP20				IP20 IP00			
Touch protection acc. to EN 50274		Finger-safe								
Short-circuit protection of contactors without overload relays										
Main circuit										
Fuse links, gL/gG operational class LV HRC, 3NA, DIAZED, 5SB, NEOZED, 5SE acc. to IEC 60947-4-1/ EN 60947-4-1		• Type of coordination *1* ¹⁾ • Type of coordination *2* ¹⁾ • Weld-free	A A A	35 20 10	63 25/35 16	160 63 50	250 125 63	250 160 100		
Control										
Magnetic coil operating range		AC at 50 Hz AC at 60 Hz DC at 50 °C DC at 60 °C AC/DC		0.8 ... 1.1 x U_s 0.85 ... 1.1 x U_s 0.8 ... 1.1 x U_s 0.85 ... 1.1 x U_s	0.8 ... 1.1 x U_s					
Power consumption of the magnetic coils (when coil is cold and 1.0 x U_s)										
• AC operation, 50 Hz		- Closing - P.f.	VA VA		61 0.82		145 0.79	270 0.68		
		- Closed - P.f.	VA VA		7.8 0.24		12.5 0.36	22 0.27		
• AC operation, 50/60 Hz		- Closing - P.f.	VA	26.5/24.3 0.79/0.75	64/63 0.82/0.74		170/155 0.76/0.72	298/274 0.72/0.62		
		- Closed - P.f.	VA	4.4/3.4 0.27/0.27	8.4/6.8 0.24/0.28		15/11.8 0.35/0.38	27/20 0.29/0.31		
• DC operation		- Closing = Closed	W	3.3	5.6		13.3	15		
Operating times for 0.8 ... 1.1 x U_s²⁾ Total break time = Opening delay + Arcing time										
• DC operation		- Closing delay - Opening delay	ms	25 ... 100 7 ... 10	30 ... 90 13 ... 40		50 ... 110 15 ... 30	110 ... 200 14 ... 20		
• AC operation		- Closing delay - Opening delay	ms	8 ... 35 4 ... 30	6 ... 30 13 ... 25		4 ... 35 10 ... 30	20 ... 50 10 ... 25		
• Arcing time			ms	10 ... 15	10 ... 15		10 ... 15	10 ... 15		
Main circuit										
AC capacity										
Utilization category AC-1, switching resistive loads										
• Rated operational currents I_e		At 40 °C, up to 690 V At 60 °C, up to 690 V	A A	18 16	22 20	35 30	40 35	60 55	110 100	140 120
• Rated power for AC loads P.f. = 0.95 (at 40 °C)		At 230 V 400 V	kW kW	7 12	8.5 14.5	12.5 22	15 26	23 39	42 72	53 92
• Minimum conductor cross-section for loads with I_e		At 40 °C At 60 °C	mm ² mm ²	2.5 2.5	2.5 2.5	10 10	10 10	16 16	50 50	50 50
Utilization category AC-2 and AC-3										
• Rated operational currents I_e		At 60 °C, up to 400 V	A	9	12	17	25	26	--	--
• Rated power of slipring or squirrel-cage motors at 50 Hz and 60 Hz		At 230 V 400 V	kW kW	3 4	3 5.5	4 7.5	5.5 11	5.5 11	-- --	-- --

¹⁾ In accordance with the corresponding 3-pole 3RT1 contactors.

²⁾ With size S00, DC operation: Operating times at 0.85 ... 1.1 x U_s .

3RT, 3RH, 3TB, 3TC, 3TH, 3TK Contactors for Special Applications

3RT13 Contactors for Switching Resistive Loads (AC-1)

4-pole, 4 NO, 18 ... 140 A

Contactor	Type Size	3RT13 16 S00	3RT13 17	3RT13 25 S0	3RT13 26
Main circuit					
<i>Load rating with DC</i>					
Utilization category DC-1, switching resistive loads ($L/R \leq 1$ ms)					
• Rated operational currents I_e (at 40 °C)					
- 1 conducting path	Up to 24 V A	18	22	35	
	60 V A	18	22	20	
	110 V A	2.1	2.1	4.5	
	220 V A	0.8	0.8	1	
	440 V A	0.6	0.6	0.4	
- 2 conducting paths in series	Up to 24 V A	18	22	35	
	60 V A	18	22	35	
	110 V A	12	12	35	
	220 V A	1.6	1.6	5	
	440 V A	0.8	0.8	1	
- 3 conducting paths in series	Up to 24 V A	18	22	35	
	60 V A	18	22	35	
	110 V A	18	22	35	
	220 V A	18	22	35	
	440 V A	1.3	1.3	2.9	
- 4 conducting paths in series	Up to 24 V A	18	22	35	
	60 V A	18	22	35	
	110 V A	18	22	35	
	220 V A	18	22	35	
	440 V A	1.3	1.3	2.9	
Utilization category DC-3/DC-5					
Shunt-wound and series-wound motors ($L/R \leq 15$ ms)					
• Rated operational currents I_e (at 40 °C)					
- 1 conducting path	Up to 24 V A	18	20	20	
	60 V A	0.5	0.5	5	
	110 V A	0.15	0.15	2.5	
	220 V A	--	--	1	
	440 V A	--	--	0.09	
- 2 conducting paths in series	Up to 24 V A	18	20	35	
	60 V A	5	5	35	
	110 V A	0.35	0.35	15	
	220 V A	--	--	3	
	440 V A	--	--	0.27	
- 3 conducting paths in series	Up to 24 V A	18	20	35	
	60 V A	18	20	35	
	110 V A	18	20	35	
	220 V A	1.5	1.5	10	
	440 V A	0.2	0.2	0.6	
- 4 conducting paths in series	Up to 24 V A	18	20	35	
	60 V A	18	20	35	
	110 V A	18	20	35	
	220 V A	1.5	1.5	35	
	440 V A	0.2	0.2	0.6	
Maximum breaking current AC					
e. g for isolation of load distributions					
• 50/60 Hz	400 V A	72	96	200	

3RT, 3RH, 3TB, 3TC, 3TH, 3TK Contactors for Special Applications

3RT13 Contactors for Switching Resistive Loads (AC-1)

4-pole, 4 NO, 18 ... 140 A

Contactors	Type Size	3RT13 36 S2	3RT13 44 S3	3RT13 46 S3
Main circuit				
<i>Load rating with DC</i>				
Utilization category DC-1, switching resistive loads ($L/R \leq 1$ ms)				
• Rated operational currents I_e (at 40 °C)				
- 1 conducting path	Up to 24 V A	50	70	80
	60 V A	23	23	60
	110 V A	4.5	4.5	9
	220 V A	1	1	2
	440 V A	0.4	0.4	0.6
- 2 conducting paths in series	Up to 24 V A	50	70	80
	60 V A	45	70	80
	110 V A	45	70	80
	220 V A	5	5	10
	440 V A	1	1	1.8
- 3 conducting paths in series	Up to 24 V A	50	70	80
	60 V A	45	70	80
	110 V A	45	70	80
	220 V A	45	70	80
	440 V A	2.9	2.9	4.5
- 4 conducting paths in series	Up to 24 V A	50	70	80
	60 V A	45	70	80
	110 V A	45	70	80
	220 V A	45	70	80
	440 V A	2.9	2.9	4.5
Utilization category DC-3/DC-5				
Shunt-wound and series-wound motors ($L/R \leq 15$ ms)				
• Rated operational currents I_e (at 40 °C)				
- 1 conducting path	Up to 24 V A	20	20	20
	60 V A	6	6	6.5
	110 V A	2.5	2.5	2.5
	220 V A	1	1	1
	440 V A	0.1	0.15	0.15
- 2 conducting paths in series	Up to 24 V A	45	70	80
	60 V A	45	70	80
	110 V A	25	70	80
	220 V A	5	7	7
	440 V A	0.27	0.42	0.42
- 3 conducting paths in series	Up to 24 V A	45	70	80
	60 V A	45	70	80
	110 V A	45	70	80
	220 V A	25	35	35
	440 V A	0.6	0.8	0.8
- 4 conducting paths in series	Up to 24 V A	45	70	80
	60 V A	45	70	80
	110 V A	45	70	80
	220 V A	45	70	80
	440 V A	0.6	0.8	0.8
Maximum breaking current AC				
e. g for isolation of load distributions				
• 50/60 Hz	400 V A	400	520	760

3RT, 3RH, 3TB, 3TC, 3TH, 3TK Contactors for Special Applications

3TK1 Contactors for Switching Resistive Loads (AC-1)

4-pole, 4 NO, 200 ... 1000 A

Overview

EN 60947-4-1 (VDE 0660 Part 102)

The contactors also comply with the requirements of NFC 63-110 and NFC 20-040.

The contactors are suitable for use in any climate. They are finger-safe according to EN 50274. Terminal covers may have to be fitted onto the connecting bars, depending on the configuration with other devices.

Magnetic coils for 3TK10 to 3TK13 contactors: as withdrawable coils.

Surge suppression

Control circuit

Magnetic coils for 3TK1 contactors: can be retrofitted with RC elements.

Function

- Isolating systems with ungrounded or poorly grounded neutral conductors
- Switching resistive loads
- System transfers when alternative AC power supplies are used
- The contactors are also suitable for switching mixed loads in distribution systems (e. g for supplying heaters, lamps, motors, PC networks) with p.f. > 0.8 according to IEC 60947-4-1 test conditions for utilization category AC-1

Technical specifications

Contactors	Type	3TK1	
Rated data of the auxiliary contacts		Acc. to IEC 60947-5-1 (VDE 0660 Part 200)	
Rated insulation voltage U_i (degree of pollution 3)	V	690	
Continuous thermal current I_{th} = Rated operational current $I_e/AC-12$	A	10	
AC load			
Rated operational current $I_e/AC-15/AC-14$			
• For rated operational voltage U_e			
	24 V	A	6
	110 V	A	6
	125 V	A	6
	220 V	A	6
	230 V	A	6
	380 V	A	4
	400 V	A	4
	500 V	A	1
	660 V	A	1
	690 V	A	1
DC load			
Rated operational current $I_e/DC-12$			
• For rated operational voltage U_e			
	24 V	A	--
	60 V	A	--
	110 V	A	--
	125 V	A	--
	220 V	A	--
	440 V	A	--
	600 V	A	--
Rated operational current $I_e/DC-13$			
• For rated operational voltage U_e			
	24 V	A	6
	60 V	A	6
	110 V	A	1.8
	125 V	A	--
	220 V	A	0.6
	440 V	A	--
	600 V	A	--
Ⓢ and Ⓜ ratings of the auxiliary contacts			
Rated voltage	V AC, max.	600	
Switching capacity		A 600, P 600	

3RT, 3RH, 3TB, 3TC, 3TH, 3TK Contactors for Special Applications

3TK1 Contactors for Switching Resistive Loads (AC-1)

4-pole, 4 NO, 200 ... 1000 A

Contactors	Type		3TK10	3TK11	3TK12	3TK13	3TK14	3TK15	3TK17
General data									
Permissible mounting position Vertical mounting position also permitted.									
Mechanical endurance	Operating cycles	Mill.	10				5		
Electrical endurance for I_e /AC-1 at 55 °C	Operating cycles	Mill.	0.8	0.8	0.8	0.4	0.65	0.5	0.4
Rated insulation voltage U_i (degree of pollution 3)		V	1000						
Ambient temperature	• During operation • During storage	°C	-25 ... +55 -50 ... +70						
Degree of protection acc. to EN 60947-1, Appendix C			IP00						
Touch protection acc. to EN 50274			Finger-safe with cover						
Shock resistance	Sine pulse	g/ms	10/15						
Short-circuit protection									
Main circuit Fuse links, gL/gG, LV HRC 3NA, DIAZED 5SB, NEOZED 5SE acc. to IEC 60947-4-1/ EN 60947-4-1									
	• Type of coordination *1*: • Type of coordination *2*:	A	250		355		800	1000	
		A	250		315		630	850	
Auxiliary circuit (short-circuit current $I_{sc} \geq 1$ kA) fuse links, gL/gG, DIAZED 5SB, NEOZED 5SE		A	10						
Control									
Magnetic coil operating range			0.85 ... 1.1 x U_s						
Power consumption of the magnetic coils (when coil is cold and 1.0 x U_s)									
• 50 Hz	- Closing - P.f.	VA	820 0.4		1100 0.35		3500 0.26		
	- Closed - P.f.	VA	44 0.34		52 0.35		125 0.4		
• 60 Hz	- Closing - P.f.	VA	990 0.35		1200 0.31		4000 0.22		
	- Closed - P.f.	VA	52 0.35		65 0.34		140 0.43		
Operating times at 1.0 x U_s									
	- Closing delay	ms	20 ... 40				30 ... 60		
	- Opening delay	ms	7 ... 15				10 ... 20		
• Arcing time		ms	10				10		
Main circuit									
AC capacity									
Utilization category AC-1, switching resistive loads									
• Rated operational currents I_e	At 40° C up to 690 V	A	200	250	300	350	550	800	1000
	At 50° C up to 690 V	A	180	230	270	310	470	650	850
• Rated power for AC loads, p.f. = 0.95 (at 40°C)	At 230 V	kW	76	95	114	132	208	303	378
	400 V	kW	132	165	197	230	362	527	658
	500 V	kW	165	206	247	288	452	658	828
	690 V	kW	227	284	341	397	624	908	1135
• Minimum conductor cross-sections for loads with I_e	At 40° C	mm ²	95	150	185	240	185	240	300
Utilization category AC-2 and AC-3									
• Rated operational currents I_e	Up to 400 V	A	120	145	210	210	400	550	700
• Rated power of squirrel-cage or slipping motors at 50 Hz and 60 Hz	At 230 V	kW	30	45	75	75	110	160	220
	400 V	kW	55	75	110	110	200	280	370
• Short-time current at 40° C in cold state up to 10 s		A	900	1200	1600	1600	5300	5300	6400
Switching frequency¹⁾									
Switching frequency z in operating cycles/hour									
• Contactors without overload relays	- No-load switching frequency	1/h	3600						
	- AC-1	1/h	300						
	- AC-3	1/h	300						

¹⁾ Dependence of the switching frequency z' on the operational current I' and operational voltage U' : $z' = z \cdot (I_e/I') \cdot (400 V/U')^{1.5} \cdot 1/h$.

3RT, 3RH, 3TB, 3TC, 3TH, 3TK Contactors for Special Applications

3TK1 Contactors for Switching Resistive Loads (AC-1)

4-pole, 4 NO, 200 ... 1000 A

Contactor	Type		3TK10	3TK11	3TK12	3TK13	3TK14	3TK15	3TK17
Conductor cross-sections									
Main conductors:			Screw terminals						
• Stranded with cable lug		mm ²	2 x 70	2 x 120	2 x 120		2 x 300		
• Solid or stranded	AWG	MCM	2 x 00	2 x 250	2 x 250		2 x 600		
• Connecting bar (max. width)		mm	30	30	33		55		
• Terminal screw			M6	M10	M10		M10		
- Tightening torque		Nm	5	16	16		16		
		lb.in	42	135	135		135		
Auxiliary conductors:									
• Solid		mm ²	2 x (0.5 ... 2.5)						
• Finely stranded with end sleeve		mm ²	2 x (0.5 ... 2.5)						
• Solid or stranded	AWG	MCM	20 ... 14						
- Tightening torque		Nm	1.2 (10 lb.in)						

Overview**AC and DC operation**

IEC 60947 (VDE 0660).

The contactors are suitable for use in any climate. The contactors with screw terminals are finger-safe according to EN 50274.

The contactors are available in versions with screw terminals, 6.3 mm plug-in terminals and solder pin connections for soldering in printed circuit boards.

Design**Auxiliary contacts****Contact reliability**

To switch voltages ≤ 110 V and currents ≤ 100 mA the 3TH2 contactor relays should be used as they guarantee a high level of contact reliability.

These auxiliary contacts are suitable for solid-state circuits with currents ≥ 1 mA at a voltage of 17 V and higher.

Short-circuit protection of the contactors

For short-circuit protection of the contactors without overload relays see "Technical specifications".

Version

The 3TK2 contactors with 4 main contacts are available with screw terminals, 6.3 mm x 0.8 mm flat connectors and solder pin connectors.

The 3TK2 contactors with 6.3 mm x 0.8 mm flat connectors are coded can be used in the plug-in base with solder pin connections for printed circuit boards.

Technical specifications**3TK20****Endurance of the main contacts**

The characteristic curves show the contact endurance of the contactors when switching inductive AC loads (AC-3) depending on the breaking current and rated operational voltage. It is assumed that the operating mechanisms are switched randomly, i. e. not synchronized with the phase angle of the supply system.

The rated operational current I_e complies with utilization category AC-4 (breaking six times the rated operational current) and is intended for a contact endurance of at least 200 000 operating cycles. If a shorter endurance is sufficient, the rated operational current $I_e/AC-4$ can be increased.

If the contacts are used for mixed operation, i. e. normal switching (breaking the rated operational current according to utilization category AC-3) in combination with intermittent inching (breaking several times the rated operational current according to utilization category AC-4), the contact endurance can be calculated approximately from the following equation:

$$X = \frac{A}{1 + \frac{C}{100} \left(\frac{A}{B} - 1 \right)}$$

Characters in the equation:

X = Contact endurance for mixed operation in operating cycles

A = Contact endurance for normal operation ($I_a = I_e$) in operating cycles

B = Contact endurance for inching ($I_a = \text{multiple of } I_e$) in operating cycles

C = Inching operations as a percentage of total switching operations

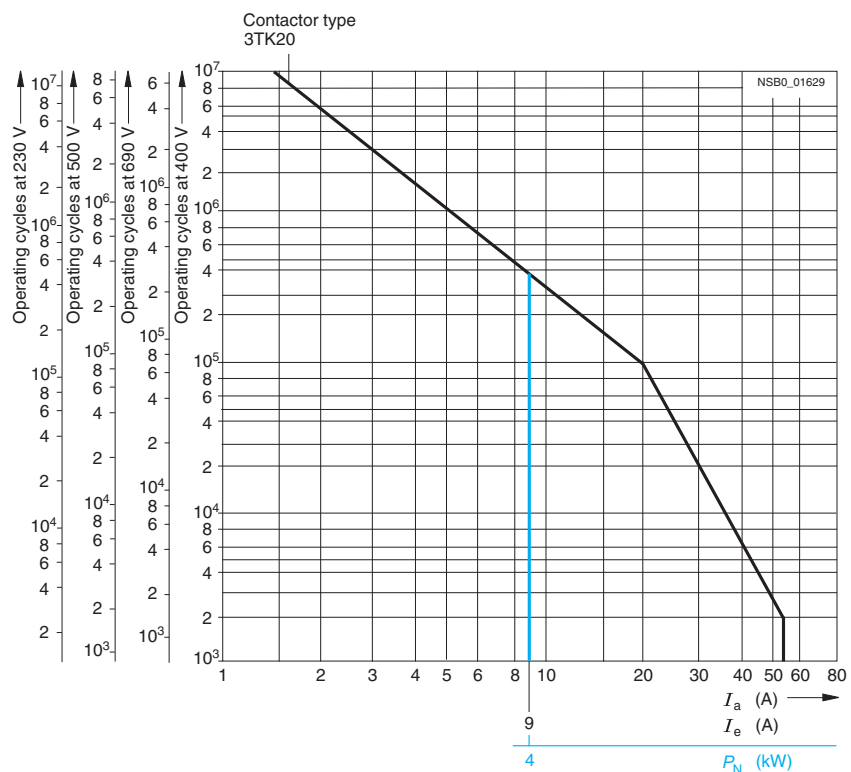

3RT, 3RH, 3TB, 3TC, 3TH, 3TK Contactors for Special Applications

3TK20 Contactors

4-pole, 4 kW

Contactors		3TK20	
Type		3TK20	
General data			
Permissible mounting position	AC and DC operation	Any	
Mechanical endurance	<ul style="list-style-type: none"> • AC operation • DC operation • Auxiliary switch block 	Operating cycles	10 million 30 million 10 million
Rated insulation voltage U_i (degree of pollution 3)			
• Screw terminals		V	690
• Flat connector 6.3 mm x 0.8 mm		V	500
• Solder pin connections		V	500
Rated impulse withstand voltage U_{imp} (degree of pollution 3)			
• Screw terminals		kV	8
• Flat connector 6.3 mm x 0.8 mm		kV	6
• Solder pin connections		kV	6
Protective separation between coil and main contacts (acc. to EN 61140)		V	Up to 300
Permissible ambient temperature ¹⁾	<ul style="list-style-type: none"> • During operation • During storage 	°C	-25 ... +55 -55 ... +80
Degree of protection acc. to EN 60947-1 Appendix C			IP00 open IP20 for screw terminals IP40 coil assembly
Touch protection			Finger-safe for screw terminals
Shock resistance			
• Rectangular pulse	<ul style="list-style-type: none"> - AC operation - DC operation 	g/ms	8.3/5 and 5.2/10 11.3/5 and 9.2/10
• Sine pulse	<ul style="list-style-type: none"> - AC operation - DC operation 	g/ms	13/5 and 8/10 17.4/5 and 12.9/10
Conductor cross-sections			
Short-circuit protection for contactors without overload relays			
Main circuit ³⁾			
• Fuse links gL/gG LV HRC 3NA, DIAZED 5SB, NEOZED 5SE acc. to IEC 60947-4-1 (VDE 0660, Part 102)	<ul style="list-style-type: none"> - Type of coordination "1" - Type of coordination "2"⁴⁾ - Weld-free 	A	25 10 10
• Miniature circuit breaker with C characteristic		A	10
Auxiliary circuit			
Short-circuit current $I_k \geq 1$ kA			
• Fuse links gL/gG DIAZED 5SB, NEOZED 5SE		A	6

1) Applies to 50/60 Hz coil:
At 50 Hz, $1.1 \times U_s$, side-by-side mounting and 100 % ON period the max. ambient temperature is +40 °C.

2) See page 3/114.

3) According to excerpt from IEC 60947-4-1 (VDE 0660 Part 102

Type of coordination "1"

Destruction of the contactor and the overload relay is permissible. The contactor and/or overload relay can be replaced if necessary.

Type of coordination "2":

The overload relay must not suffer any damage. Contact welding on the contactor is permissible, however, if the contacts can be easily separated.

4) A short-circuit current of $I_q \leq 6$ kA applies to type of coordination "2".

Contactors			
Type	3TK20		
Control			
Magnetic coil operating range¹⁾	0.8 ... 1.1 x U_s		
Power consumption of the magnetic coils (when coil is cold and 1.0 x U_s)			
Standard version:			
• AC operation, 50 Hz	Closing	VA	15
	P.f.		0.41
	Closed	VA	6.8
	P.f.		0.42
• AC operation, 60 Hz	Closing	VA	14.4
	P.f.		0.36
	Closed	VA	6.1
	P.f.		0.46
• AC operation, 50/60 Hz ¹⁾	Closing	VA	16.5/13.2
	P.f.		0.43/0.38
	Closed	VA	8.0/5.4
	P.f.		0.48/0.42
For USA and Canada:			
• AC operation, 50 Hz	Closing	VA	14.6
	P.f.		0.38
	Closed	VA	6.5
	P.f.		0.40
• AC operation, 60 Hz	Closing	VA	14.4
	P.f.		0.30
	Closed	VA	6.0
	P.f.		0.44
• DC operation	Closing = Closed	W	3
Permissible residual current of the electronic circuit²⁾ (for 0 signal)			
	• AC operation	mA	$\leq 3 \times (230 \text{ V}/U_s)$
	• DC operation	mA	$\leq 1 \times (230 \text{ V}/U_s)$
Operating times at 0.8 ... 1.1 x U_s³⁾			
Total break time = Opening delay + Arcing time			
Values apply with coil in cold state and at operating temperature for operating range			
• AC operation	Closing delay	ms	5 ... 19
	Opening delay	ms	2 ... 22
- Dead interval			To use the 3TK20 AC-operated contactor in reversing duty an additional dead interval of 50 ms is required along with an NC contact interlock.
• DC operation	Closing delay	ms	16 ... 65
	Opening delay	ms	2 ... 5
• Arcing time		ms	10 ... 15
Operating times at 1.0 x U_s³⁾			
• AC operation	Closing delay	ms	5 ... 18
	Opening delay	ms	3 ... 21
- Dead interval			To use the 3TK20 AC-operated contactor in reversing duty an additional dead interval of 50 ms is required along with an NC contact interlock.
• DC operation	Closing delay	ms	19 ... 31
	Opening delay	ms	3 ... 4
• Arcing time		ms	10 ... 15

¹⁾ Applies to 50/60 Hz coil:
At 50 Hz, 1.1 x U_s , side-by-side mounting and 100 % ON period the max. ambient temperature is +40 °C.

²⁾ The 3TX4 490-1J additional load module is recommended for higher residual currents (see Catalog LV 1).

³⁾ The OFF-delay of the NO contacts and ON-delay of the NC contacts increase if the contactor coils are protected against voltage peaks (noise suppression diode 6 to 10 times, diode assemblies 2 to 6 times, varistor +2 to 5 ms).

3RT, 3RH, 3TB, 3TC, 3TH, 3TK Contactors for Special Applications

3TK20 Contactors

4-pole, 4 kW

Contactors	Type	3TK20 ...0...	3TK20 ...3..., 3TK20 ...6..., 3TK20 ...7...
Size 00			
Main circuit			
AC capacity			
Utilization category AC-1, switching resistive loads			
• Rated operational current I_e (at 40 °C)	Up to 400/380 V A 690/660 V A	18 18	18 --
• Rated operational current I_e (at 55 °C)	400/380 V A 690/660 V A	16 16	16 --
• Rated power of AC loads P.f. = 1	At 230/220 V kW 400/380 V kW 500 V kW 690/660 V kW	6.0 10 13 17	6.0 10 13 --
• Minimum conductor cross-section for loads with I_e	mm ²	2.5	2.5
Utilization category AC-2 and AC-3			
• Rated operational current I_e	Up to 220 V A 230 V A 380 V A 400 V A 500 V A 660 V A 690 V A	9.0 9.0 9.0 8.4 6.5 5.2 5.2	9.0 9.0 9.0 8.4 6.5 -- --
• Rated power for motors with slipring or squirrel-cage rotors at 50 Hz and 60 Hz and	At 110 V kW 115 V kW 120 V kW 127 V kW 200 V kW 220 V kW 230 V kW 240 V kW 380 V kW 400 V kW 415 V kW 440 V kW 460 V kW 500 V kW 575 V kW 660 V kW 690 V kW	1.2 1.2 1.3 1.4 2.2 2.4 2.5 2.6 4.0 4.0 4.0 4.0 4.0 4.0 4.0 4.0 4.0	1.2 1.2 1.3 1.4 2.2 2.4 2.5 2.6 4.0 4.0 4.0 4.0 4.0 4.0 -- -- --
Utilization category AC-4			
(contact endurance approx. 200000 operating cycles at $I_a = 6 \times I_e$)			
• Rated operational current I_e	Up to 400 V A 690 V A	2.6 1.8	2.6 --
• Rated power for motors with squirrel-cage rotor at 50 and 60 Hz and	At 110 V kW 115 V kW 120 V kW	0.32 0.33 0.35	0.32 0.33 0.35
• Max. permissible rated operational current $I_e/AC-4 \cong I_e/AC-3$ up to 500 V, for reduced contact endurance and reduced switching frequency	127 V kW 200 V kW 220 V kW 230 V kW 240 V kW 380 V kW 400 V kW 415 V kW 440 V kW 460 V kW 500 V kW 575 V kW 660 V kW 690 V kW	0.37 0.58 0.64 0.67 0.70 1.10 1.15 1.20 1.27 1.33 1.45 1.30 1.10 1.15	0.37 0.58 0.64 0.67 0.70 1.10 1.15 1.20 1.27 1.33 1.45 -- -- --

Contactors	Type	3TK20 ...0...	3TK20 ...-3..., 3TK20 ...-6..., 3TK20 ...-7...
Size 00			
Main circuit			
AC capacity			
Utilization category AC-5a, switching gas discharge lamps			
Per main current path at 230/220 V			
• Rated power per lamp	Rated operational current per lamp (A)		
- Uncorrected			
L 18 W	0.37	Units 43	
L 36 W	0.43	Units 37	
L 58 W	0.67	Units 23	
- DUO switching			
L 18 W	0.11	Units 144	
L 36 W	0.21	Units 76	
L 58 W	0.32	Units 50	
Switching gas discharge lamps with correction, solid-state ballast			
Per main current path at 230/220 V			
• Rated power per lamp	Capacitance (μF)	Rated operational current per lamp (A)	
- Parallel correction			
L 18 W	4.5	0.11	Units 22
L 36 W	4.5	0.21	Units 22
L 58 W	7	0.31	Units 14
- With solid-state ballast (single lamp)			
L 18 W	6.8	0.10	Units 63
L 36 W	6.8	0.18	Units 35
L 58 W	10	0.27	Units 23
- With solid-state ballast (two lamps)			
L 18 W	10	0.18	Units 35
L 36 W	10	0.35	Units 18
L 58 W	22	0.52	Units 12
Utilization category AC-5b, switching incandescent lamps		kW	1.6
Per main current path at 230/220 V			--
Utilization category AC-6a, switching AC transformers			
• Rated operational current I_e			
- For inrush current $n = 20$	At 400 V	A	5.1
- For inrush current $n = 30$	At 400 V	A	3.3
• Rated power P			
- For inrush current $n = 20$	Up to 230/220 V	kVA	2.0
	400/380 V	kVA	3.5
	500 V	kVA	4.6
	690/660 V	kVA	6.0
- For inrush current $n = 30$	Up to 230/220 V	kVA	1.3
	400/380 V	kVA	2.3
	500 V	kVA	3.1
	690/660 V	kVA	4.0
For deviating inrush current factors x , the power must be recalculated as follows: $P_x = P_{n30} \times (30/x)$			
Utilization category AC-6b, switching low-inductance (low-loss, metallized dielectric) AC capacitors		No switching capacity	
Utilization category AC-7a, switching low inductive loads in household appliances			
• Rated operational current I_e (at 55 °C)	At 400/380 V	A	16
	690/660 V	A	16
• Rated power at 50 and 60 Hz	At 230/220 V	kW	6
	400/380 V	kW	10
• Minimum conductor cross-section for loads with I_e		mm ²	2.5
Utilization category AC-7b, switching motor loads in household appliances			
• Rated operational current I_e	Up to 220 V	A	9.0
	230 V	A	9.0
	380 V	A	9.0
	400 V	A	8.4
• Rated power of motors at 50 and 60 Hz and	At 110 V	kW	1.2
	220 V	kW	2.4
	230 V	kW	2.5
	240 V	kW	2.6
	380 V	kW	4.0
	400 V	kW	4.0

3RT, 3RH, 3TB, 3TC, 3TH, 3TK Contactors for Special Applications

3TK20 Contactors

4-pole, 4 kW

Contactor	Type	3TK20 ...0...	3TK20 ...3..., 3TK20 ...6..., 3TK20 ...7...
Size 00			
Main circuit			
<i>Load rating with DC</i>			
Utilization category DC-1, switching resistive loads (contact endurance 0.1×10^6 operating cycles; $L/R \leq 1$ ms)			
• Rated operational current I_{θ} (at 55 °C)			
- 1 conducting path	Up to 24 V A 60 V A 110 V A 220/240 V A	16 6 2 1	16 6 2 1
- 2 conducting paths in series	Up to 24 V A 60 V A 110 V A 220/240 V A	16 16 6 2	16 16 6 2
- 3 conducting paths in series	Up to 24 V A 60 V A 110 V A 220/240 V A	16 16 16 6	16 16 16 6
Utilization category DC-3 and DC-5, shunt-wound and series-wound motors ($L/R \leq 15$ ms)			
• Rated operational current I_{θ} (at 55 °C)			
- 1 conducting path	Up to 24 V A 60 V A 110 V A 220/240 V A	6 3 0.5 0.1	6 3 0.5 0.1
- 2 conducting paths in series	Up to 24 V A 60 V A 110 V A 220/240 V A	10 5 2 0.5	10 5 2 0.5
- 3 conducting paths in series	Up to 24 V A 60 V A 110 V A 220/240 V A	16 16 16 2	16 16 16 2
Thermal load capacity		10 s current A	70
Power loss per conducting path		At $I_{\theta}/AC-3$ W	0.3
<i>Switching frequency</i>			
Switching frequency z in operating cycles/hour			
• Contactors without overload relays	No-load switching frequency	h^{-1}	10000
Dependence of the switching frequency z' on the operational current I' and operational voltage U': $z' = z \cdot (I_{\theta}/I') \cdot (400 V/U')^{1.5} \cdot 1/h$	AC-1	h^{-1}	1000
	AC-2	h^{-1}	500
	AC-3	h^{-1}	1000
• Contactors with overload relays (mean value)		h^{-1}	15
Conductor cross-sections			
Main and auxiliary conductors			
• Solid		mm ²	2 x (0.5 ... 2.5), 1 x 4 2 x (20 ... 14) AWG, 1 x 12 AWG
• Finely stranded with end sleeve		mm ²	2 x (0.5 ... 1.5), 1 x 2.5
• Pin-end connector (DIN 46231)		mm ²	1 x 1 ... 2.5
• Terminal screw			M3
• Prescribed tightening torque for terminal screws		Nm lb.in	0.8 ... 1.3 7 ... 11
Flat connectors			
• When using a plug-in sleeve	6.3 ... 1	mm ²	0.5 ... 1
• Finely stranded	6.3 ... 2.5	mm ²	1 ... 2.5
Solder pin connections (only for printed circuit boards)			

3RT, 3RH, 3TB, 3TC, 3TH, 3TK Contactors for Special Applications

3TK20 Contactors

4-pole, 4 kW

Contactors	Type	3TK20 ...-0...	3TK20 ...-3..., 3TK20 ...-6..., 3TK20 ...-7...
Size 00			
Ⓢ and Ⓣ rated data of the 3TK20 contactors			
Rated insulation voltage U_i	V AC	600	300
Uninterrupted current	• Open and enclosed A	16	16 (10 for solder pin connection)
Maximum horsepower ratings (Ⓢ and Ⓣ approved values)			
• Rated power for induction motors at 60 Hz			
- 1-phase	At 115 V hp	0.5	--
	200 V hp	1	1
	230 V hp	1.5	1
	460/575 V hp	--	--
- 3-phase	At 115 V hp	--	--
	200 V hp	3	3 (1 for 3TK20 ...-6)
	230 V hp	3	3 (1 for 3TK20 ...-6)
	460/575 V hp	5	--
Overload relay	Type/Setting range	3UA7/EB 8 ... 10 A	

Contactors	Type	3TK20
Size 00		
Rated data of the auxiliary contacts acc. to IEC 60947-5-1 (VDE 0660 Part 200)		
Rated insulation voltage U_i (degree of pollution 3)	V	690
Continuous thermal current $I_{th} =$ Rated operational current $I_e/AC-12$	A	10
AC load		
Rated operational current $I_e/AC-15/AC-14$		
• For rated operational voltage U_e	24 V A	4
	110 V A	4
	125 V A	4
	220 V A	4
	230 V A	4
	380 V A	3
	400 V A	3
	500 V A	2
	660 V A	1
	690 V A	1
DC load		
Rated operational current $I_e/DC-12$		
• For rated operational voltage U_e	24 V A	4
	48 V A	2.2
	110 V A	1.1
	125 V A	1.1
	220 V A	0.5
	440 V A	--
	600 V A	--
Rated operational current $I_e/DC-13$		
• For rated operational voltage U_e	24 V A	2.1
	48 V A	1.1
	110 V A	0.52
	125 V A	0.52
	220 V A	0.27
	440 V A	--
	600 V A	--
Ⓢ, Ⓣ and Ⓜ rated data of the auxiliary contacts		
Rated voltage, max.	V AC	600
Auxiliary switch blocks, max.	V AC	300
Switching capacity		A 600, Q 300
Uninterrupted current at 240 V AC	A	10

3RT, 3RH, 3TB, 3TC, 3TH, 3TK Contactors for Special Applications

3RT15 Contactors

4-pole, 2 NO + 2 NC, 4 ... 18.5 kW

Overview

AC and DC operation

EN 60947-4-1 (VDE 0660 Part 102).

The contactors are suitable for use in any climate. They are finger-safe according to EN 50274.

The accessories for the 3-pole SIRIUS contactors can also be used for the 4-pole versions.

Function

- Changing the polarity of hoisting gear motors
- Switching two separate loads

Note:

Single device for pole reversal; not suitable for reversing duty. 3RT15 contactors are not suitable for switching a load between two current sources.

Integration

Mountable auxiliary contacts

Size S00

4 auxiliary contacts (auxiliary switch blocks according to EN 50005)

Size S0

Maximum 2 auxiliary contacts (either laterally mounted or snapped onto the top auxiliary switch blocks according to EN 50012 and EN 50005).

Size S2

Maximum 4 auxiliary contacts (either laterally mounted or snapped onto the top auxiliary switch blocks to EN 50012 and EN 50005).

Technical specifications

Contactors	Type Size		3RT15 16 S00	3RT15 17 S00	3RT15 26 S0	3RT15 35 S2
General data						
Permissible mounting position¹⁾						
Mechanical endurance			Operating cycles	30 million	10 million	
Electrical endurance at $I_e/AC-1$			Operating cycles	Approx. 0.5 million		
Rated insulation voltage U_i (degree of pollution 3)			V	690		
Permissible ambient temperature						
			• During operation	°C -25 ... +60		
			• During storage	°C -55 ... +80		
Degree of protection acc. to EN 60947-1, Appendix C				IP20	IP20 (IP00 terminal compartment)	
Touch protection acc. to EN 50274				Finger-safe		
Short-circuit protection of contactors without overload relays						
Main circuit						
Fuse links, gL/gG	• Type of coordination "1"	A	35		63	160
LV HRC 3NA, DIAZED 5SB, NEOZED 5SE	• Type of coordination "2"	A	20		35	80
Acc. to IEC 60947-4-1/ EN 60947-4-1	• Weld-free	A	10		16	50
Control						
Magnetic coil operating range						
	AC at 50 Hz		0.8 ... 1.1 x U_s			
	AC at 60 Hz		0.85 ... 1.1 x U_s			
	DC at 50 °C		0.8 ... 1.1 x U_s			
	DC at 60 °C		0.85 ... 1.1 x U_s			
	AC/DC				0.8 ... 1.1 x U_s	
Power consumption of the magnetic coils (when coil is cold and 1.0 x U_s)						
• AC operation, 50 Hz	- Closing	VA			61	145
	- P.f.	VA			0.82	0.79
	- Closed	VA			7.8	12.5
	- P.f.	VA			0.24	0.36
• AC operation, 50/60 Hz	- Closing	VA	26.5/24.3		64/63	170/155
	- P.f.	VA	0.79/0.75		0.82/0.74	0.76/0.72
	- Closed	VA	4.4/3.4		8.4/6.8	15/11.8
	- P.f.	VA	0.27/0.27		0.24/0.28	0.35/0.38
• DC operation	- Closing = Closed	W	3.3		5.6	13.3
Operating times for 0.8 ... 1.1 x U_s²⁾						
Total break time = Opening delay + Arcing time						
AC/DC operation						
• DC operation	- Closing delay	ms	25 ... 100		30 ... 90	50 ... 110
	- Opening delay	ms	7 ... 10		13 ... 40	15 ... 30
• AC operation	- Closing delay	ms	8 ... 35		6 ... 30	4 ... 35
	- Opening delay	ms	4 ... 30		13 ... 25	10 ... 30
• Arcing time		ms	10 ... 15			

1) In accordance with the corresponding 3-pole 3RT1 contactors.

2) With size S00, DC operation: operating times at 0.85 ... 1.1 x U_s .

3RT, 3RH, 3TB, 3TC, 3TH, 3TK Contactors for Special Applications

3RT15 Contactors

4-pole, 2 NO + 2 NC, 4 ... 18.5 kW

Contactors	Type Size	3RT15 16 S00	3RT15 17 S00	3RT15 26 S0	3RT15 35 S2
Main circuit					
AC capacity					
Utilization category AC-1, switching resistive loads					
• Rated operational currents I_e	At 40 °C up to 690 V A	18	22	40	60
	At 60 °C up to 690 V A	16	20	35	55
• Rated power for AC loads P.f. = 0.95 (at 60 °C)	At 230 V kW	6.5	7.5	15	20
	400 V kW	11	13	26	36
• Minimum conductor cross-section for loads with I_e	At 40 °C mm ²	2.5	2.5	10	16
Utilization category AC-2 and AC-3					
• Rated operational currents I_e (at 60 °C)	Up to 400 V A	9	12	25 ¹⁾	40
	At 230 V kW	3	3	5.5	9.5
• Rated power of slipping or squirrel-cage motors at 50 and 60 Hz	400 V kW	4	5.5	11	18.5
Load rating with DC					
Utilization category DC-1, switching resistive load ($L/R \leq 1$ ms)					
• Rated operational currents I_e (at 60 °C)					
- 1 conducting path	Up to 24 V A	16	20	35	50
	60 V A	16	20	20	23
	110 V A	2.1	2.1	4.5	4.5
	220 V A	0.8	0.8	1	1
	440 V A	0.6	0.6	0.4	0.4
- 2 conducting paths in series	Up to 24 V A	16	20	35	50
	60 V A	16	20	35	45
	110 V A	12	12	35	45
	220 V A	1.6	1.6	5	5
	440 V A	0.8	0.8	1	1
Utilization category DC-3/DC-5²⁾, shunt-wound and series-wound motors ($L/R \leq 15$ ms)					
• Rated operational currents I_e (at 60 °C)					
- 1 conducting path	Up to 24 V A	16	20	20	35
	60 V A	0.5	0.5	5	6
	110 V A	0.15	0.15	2.5	2.5
	220 V A	0.75	0.75	1	1
	440 V A	--	--	0.09	0.1
- 2 conducting paths in series	Up to 24 V A	16	20	35	50
	60 V A	5	5	35	45
	110 V A	0.35	0.35	15	25
	220 V A	--	--	3	5
	440 V A	--	--	0.27	0.27

¹⁾ For AC operation: 25 A
DC operation: 20 A.

²⁾ For $U_s > 24$ V the rated operational currents I_e for the NC contact conducting paths are 50 % of the values for the NO contact conducting paths.

3RT, 3RH, 3TB, 3TC, 3TH, 3TK Contactors for Special Applications

3RT16 Capacitor Contactors

12.5 ... 50 kvar

Overview

AC operation

IEC 60947, EN 60947 (VDE 0660)

The contactors are suitable for use in any climate. They are finger-safe according to EN 50274.

The 3RT16 capacitor contactors are special version of the size S00 to S3 SIRIUS contactors. The capacitors are precharged by means of the mounted leading NO contacts and resistors; only then do the main contacts close.

This prevents disturbances in the network and welding of the contactors.

Only discharged capacitors are permitted to be switched on with capacitor contactors.

The auxiliary switch block which is snapped onto the capacitor contactor contains the three leading NO contacts and in the case of S00 one standard NC contact and in the case of S0 and S3 one standard NO contact, which is unassigned. Size S00 also contains another unassigned NO contact in the basic unit.

In addition, a 2-pole auxiliary switch block can be mounted laterally on the 3RT16 47 capacitor contactors (2 NO, 2 NC or 1 NO + 1 NC versions); Type 3RH19 21-1EA... The fitting of auxiliary switches for 3RT16 17 and 3RT16 27 is not expandable.

For the capacitor switching capacity of the basic 3RT10 contactor version, see "Technical specifications".

Technical specifications

All technical specifications not mentioned in the table below are identical to those of the 3RT10 17 contactors for size S00, to those of the 3RT10 26 contactors for size S0 and to those of the 3RT10 45 contactors for size S3.



Contactors	Type Size		3RT16 17-.A..3 S00	3RT16 27-.A..1 S0	3RT16 47-.A..1 S3
Capacitor rating at rated power (utilization category AC-6b)		230 V, 50/60 Hz kvar	3 ... 7.5	3.5 ... 15	3.5 ... 30
		400 V, 50/60 Hz kvar	5 ... 12.5	6 ... 25	5 ... 50
		525 V, 50/60 Hz kvar	7.5 ... 15	7.8 ... 30	7.5 ... 60
		690 V, 50/60 Hz kvar	10 ... 21	10 ... 42	10 ... 84
Auxiliary contacts mounted (unassigned)			1 NO + 1 NC	1 NO contact	
Auxiliary contacts mountable (lateral), not for sizes S00 and S0			--		2 NC + 2 NO or 1 NO + 1 NC
Magnetic coil operating range			0.8 ... 1.1 x U_s		
Max. switching frequency		h^{-1}	180	100	
Electrical endurance		Oper- ating cycles	> 250000	> 150000	> 100000
Ambient temperature		°C	60		
Standards			IEC 60947/EN 60947 (VDE 0660)		
Short-circuit protection			1.6 ... 2.2 x I_e		
Conductor cross-sections (1 or 2 conductors connectable)					
Main conductor			Screw terminals		
• Solid	mm ²	2 x (0.5 ... 1.5); 2 x (0.75 ... 2.5) Acc. to IEC 60947; Max. 2 x (1 ... 4)	2 x (1 ... 2.5); 2 x (2.5 ... 6) Acc. to IEC 60947; Max. 1 x 10 ¹⁾	--	--
• Finely stranded with end sleeve	mm ²	2 x (0.5 ... 1.5); 2 x (0.75 ... 2.5)	2 x (1 ... 2.5); 2 x (2.5 ... 6) ¹⁾	--	--
• AWG cables					
- Solid	AWG	2 x (20 ... 16)	2 x (16 ... 12)	--	--
- Solid or stranded	AWG	2 x (18 ... 14)	2 x (14 ... 10)	--	--
- Stranded	AWG	1 x 12	1 x 8	--	--
• Terminal screws		M3	M4 (Pozidriv size 2)	--	--
- Tightening torque	Nm	0.8 ... 1.2	2 ... 2.5	--	--
	lb.in	7 ... 10.3	18 ... 22	--	--

1) 3RV19 25-5AB feeder terminal for 16 mm².

3RT, 3RH, 3TB, 3TC, 3TH, 3TK Contactors for Special Applications

3RT16 Capacitor Contactors

12.5 ... 50 kvar

Contactors	Type Size	3RT16 17-.A..3 S00	3RT16 27-.A..1 S0	3RT16 47-.A..1 S3
Conductor cross-sections (1 or 2 conductors connectable)				
		⊕ Screw terminals		
Front clamping point connected 	Main conductors: With box terminal			
	• Finely stranded with end sleeve	mm ²	--	2.5 ... 35
	• Finely stranded without end sleeve	mm ²	--	4 ... 50
	• Solid	mm ²	--	2.5 ... 16
	• Stranded	mm ²	--	4 ... 70
• Ribbon cable conductors (number x width x thickness)	mm	--	6 x 9 x 0.8	
• AWG cables, solid or stranded	AWG	--	10 ... 2/0	
Rear clamping point connected 	• Finely stranded with end sleeve	mm ²	--	2.5 ... 50
	• Finely stranded without end sleeve	mm ²	--	10 ... 50
	• Solid	mm ²	--	2.5 ... 16
	• Stranded	mm ²	--	10 ... 70
	• Ribbon cable conductors (number x width x thickness)	mm	--	6 x 9 x 0.8
• AWG cables, solid or stranded	AWG	--	10 ... 2/0	
Both clamping points connected 	• Finely stranded with end sleeve	mm ²	--	Max. 2 x 35
	• Finely stranded without end sleeve	mm ²	--	Max. 2 x 35
	• Solid	mm ²	--	Max. 2 x 16
	• Stranded	mm ²	--	Max. 2 x 50
	• Ribbon cable conductors (number x width x thickness)	mm	--	2 x (6 x 9 x 0.8)
• AWG cables, solid or stranded	AWG	--	2 x (10 ... 1/0)	
• Terminal screw - Tightening torque	Nm lb.in	-- --	-- --	M6 (hex. socket, A/F 4) 4 ... 6 36 ... 53
Connection for drilled copper bars ¹⁾	Max. width	mm	--	10
Without box terminal with cable lugs ²⁾ (1 or 2 conductors can be connected)	• Finely stranded with cable lug	mm ²	--	10 ... 50 ³⁾
	• Stranded with cable lug	mm ²	--	10 ... 70 ³⁾
	• AWG cables, solid or stranded	AWG	--	7 ... 1/0
Auxiliary conductors:				
• Solid	mm ²	2 x (0.5 ... 1.5) ⁴⁾ ; 2 x (0.75 ... 2.5) ⁴⁾ acc. to IEC 60947; max. 2 x (1 ... 4)	2 x (0.5 ... 1.5) ⁴⁾ ; 2 x (0.75 ... 2.5) ⁴⁾ acc. to IEC 60947; max. 2 x (0.75 ... 4)	
• Finely stranded with end sleeve	mm ²	2 x (0.5 ... 1.5) ⁴⁾ ; 2 x (0.75 ... 2.5) ⁴⁾		
• AWG cables, solid or stranded	AWG	2 x (20 ... 16) ⁴⁾ ; 2 x (18 ... 14) ⁴⁾ ; 1 x 12		
• Terminal screw - Tightening torque	Nm lb.in	M3 0.8 ... 1.2 7 ... 10.3		

¹⁾ If bars larger than 12 x 10 mm are connected, a 3RT19 46-4EA1 terminal cover is needed to comply with the phase clearance.

²⁾ When connecting conductors which are larger than 25 mm², the 3RT19 46-4EA1 terminal cover must be used to keep the phase clearance.

³⁾ Only with crimped cable lugs according to DIN 46234. Cable lug max. 20 mm wide.

⁴⁾ If two different conductor cross-sections are connected to one clamping point, both cross-sections must lie in the range specified. If identical cross-sections are used, this restriction does not apply.

3RT, 3RH, 3TB, 3TC, 3TH, 3TK Contactors for Special Applications

Contactors with Extended Operating Range $0.7 \dots 1.25 \times U_s$, for Railway Applications

3RH11 contactor relays

Overview

DC operation

IEC 60947-4-1, EN 60947-4-1 (VDE 0660, Part 102), for requirements according to IEC 60077-1 and IEC 60077-2.

The contactor relays are finger-safe according to EN 50274. The size S00 contactor relays have Cage Clamp connections for all terminals.

Ambient temperature

The permissible ambient temperature for operation of the contactor relays (across the full magnetic coil operating range) is -40 °C to $+70 \text{ °C}$.

Uninterrupted duty at temperatures $> +60 \text{ °C}$ reduces the mechanical endurance, the current-carrying capacity of the conducting paths and the switching frequency.

Function

Control and auxiliary circuits

The magnetic coils of the contactor relays have an extended operating range from 0.7 to $1.25 \times U_s$ and are fitted as standard with varistors to provide protection against overvoltage. The opening delay is consequently 2 to 5 ms longer than for standard contactors.

3RH11 ..-0LA0

The DC solenoid systems of the contactor relays are modified (to holding excitation) by means of a series resistor.

The size S00 contactor relays are supplied prewired with a plug-on module containing the series resistor. The varistor is integrated. A 4-pole auxiliary switch block (according to EN 50005) can be fitted additionally.

Mounting

At ambient temperatures up to 70 °C , the size S00 contactor relays are allowed to be mounted side by side.

3RH11 22-2K.40

These contactor relays have an extended operating range from 0.7 to $1.25 \times U_s$; the coils are fitted with varistors as standard. An additional series resistor is not required. Please note:

- Size S00: it is not possible to mount an auxiliary switch block.

At ambient temperatures $> 60 \text{ °C} \leq 70 \text{ °C}$, a clearance of 10 mm is required when they are mounted side by side.

Technical specifications

Contactors	Type		3RH11 .
Magnetic coil operating range	AC/DC		$0.7 \dots 1.25 \times U_s$
Power consumption of the magnetic coils			For cold coil and $1.0 \times U_s$
• Contactors with series resistor	- Closing	W	11
	- Closed	W	4
• Contactors without series resistor	- Closing	W	2.3
	- Closed	W	2.3
Upright mounting position			3RH11 22-2K.40: please ask 3RH11 22-2K.40-0LA0 standard version

All specifications and technical specifications not mentioned here are identical to those of the standard contactors.

3RT, 3RH, 3TB, 3TC, 3TH, 3TK Contactors for Special Applications

Contactors with Extended Operating Range $0.7 \dots 1.25 \times U_s$, for Railway Applications

3TH4 contactor relays

Overview

3TH4 contactor relays

EN 60947-4-1.

For requirements according to IEC 60077-1 and IEC 60077-2.

The contactors are finger-safe according to EN 50274. Terminal covers may have to be fitted onto the connecting bars, depending on the configuration with other devices.

Function

Control and auxiliary circuits

The magnetic coils of the contactors have an extended coil operating range from 0.7 to $1.25 \times U_s$ and are fitted as standard with varistors to provide protection against overvoltage. The opening delay is consequently 2 ms to 5 ms longer than for standard contactors.

All specifications and technical specifications not mentioned here are identical to those of the standard 3TH4 contactor relays.

Ambient temperature

The permissible ambient temperature for operation of the contactors (across the full operating range of the magnetic coil) is -50 to $+70$ °C. Uninterrupted duty at temperatures < -25 °C and $> +55$ °C reduces the mechanical endurance, the current-carrying capacity of the conducting paths and the switching frequency.

Mounting

At ambient temperatures > 55 °C, a distance of 10 mm must be observed if contactor relays and size 1 and 2 contactors are mounted side by side. There is no need to reduce the technical specifications.

Technical specifications

Contactors	Type	3TH42	
Magnetic coil operating range		$0.7 \dots 1.25 \times U_s$	
Power consumption of the magnetic coils (for cold coil)			
	$0.7 \times U_s$ W	2.6	
	$1.0 \times U_s$ W	5.2	
	$1.25 \times U_s$ W	8.2	
(For cold coil: Closing = Closed)			
Permissible ambient temperature	• During operation	°C	$-50 \dots +70$ ¹⁾
	• During storage	°C	$-55 \dots +80$
Permissible residual current of the electronics (with 0 signal)	DC operation	$\leq 10 \text{ mA} \times (24 \text{ V}/U_s)$	
Operating times (Total break time = OFF-delay + Arcing time)			
• Closing			
- $0.7 \times U_s$	ON-delay (NO)	ms	70 ... 200
	OFF-delay (NC)	ms	28 ... 33
- $1 \times U_s$	ON-delay (NO)	ms	45 ... 80
	OFF-delay (NC)	ms	30 ... 34
- $1.25 \times U_s$	ON-delay (NO)	ms	40 ... 60
	OFF-delay (NC)	ms	31 ... 35
• Opening			
- $0.7 \dots 1.25 \times U_s$	OFF-delay (NO)	ms	20 ... 30
	ON-delay (NC)	ms	22 ... 32
• Arcing time			
		ms	10

¹⁾ Side-by-side mounting with 10 mm distance.

3RT, 3RH, 3TB, 3TC, 3TH, 3TK Contactors for Special Applications

Contactors with Extended Operating Range $0.7 \dots 1.25 \times U_s$, for Railway Applications

3RT10 motor contactors, 5.5 ... 45 kW

Overview

DC operation

IEC 60947-4-1, EN 60947-4-1 (VDE 0660, Part 102), for requirements according to IEC 60077-1 and IEC 60077-2.

The contactors are finger-safe according to EN 50274 (exception: series resistors S0 to S3). The contactors are available with both Cage Clamp and screw connection. The size S00 contactors have Cage Clamp terminals for all connections. The auxiliary conductor and coil terminals of sizes S0 to S3 are all Cage Clamp terminals.

Ambient temperature

The permissible ambient temperature for operation of the contactors (across the full magnetic coil operating range) is $-40 \text{ }^\circ\text{C}$ to $+70 \text{ }^\circ\text{C}$.

Uninterrupted duty at temperatures $> +60 \text{ }^\circ\text{C}$ reduces the mechanical endurance, the current-carrying capacity of the conducting paths and the switching frequency.

Dimensions

Attaching resistors increases the width of contactor sizes S0 to S3 (see "Dimensional Drawings").

Function

Control and auxiliary circuits

The magnetic coils of the contactors have an extended operating range from 0.7 to $1.25 \times U_s$ and are fitted as standard with varistors to provide protection against overvoltage. The opening delay is consequently 2 to 5 ms longer than for standard contactors.

3RT10 ..-0LA0

The DC solenoid systems of the contactors are modified (to holding excitation) by means of a series resistor.

The size S00 contactors are supplied prewired with a plug-on module containing the series resistor. The varistor is integrated. A 4-pole auxiliary switch block (according to EN 50005) can be fitted additionally.

The size S0 to S3 contactors are equipped on the front with an auxiliary switch block with 2 NO + 2 NC contacts. The separate series resistor, which is attached laterally next to the contactor on the 35 mm standard mounting rail, is fitted with connecting cables for mounting onto contactors. A circuit diagram showing the terminals is stuck onto each contactor. One NC of the auxiliary contacts is required for the series resistor function. The selection and ordering data shows the number of additional, unassigned auxiliary contacts. It is only possible to extend the number of auxiliary contacts with size S00.

Mounting

At ambient temperatures up to $70 \text{ }^\circ\text{C}$, the size S00 contactors and contactor relays are allowed to be mounted side by side. The resistor module of the size S0 to S3 contactors must be mounted to the left of the contactor owing to the prefabricated connecting cables.

3RT10 17-2K.4., 3RT10 2.-3K.40

These contactors have an extended operating range from 0.7 to $1.25 \times U_s$; the coils are fitted with varistors as standard. An additional series resistor is not required. Please note:

- Size S00: it is not possible to mount an auxiliary switch block.
- Size S0: up to two single-pole auxiliary switch blocks can be mounted.

At ambient temperatures $> 60 \text{ }^\circ\text{C} \leq 70 \text{ }^\circ\text{C}$, a clearance of 10 mm is required when they are mounted side by side.

3RT10 contactors with contactor control unit, extended operating range

Control and auxiliary circuits

The magnetic coils of the contactors have an extended operating range from 0.7 to $1.25 \times U_s$ and are fitted as standard with varistors to provide protection against overvoltage. The opening delay is consequently 2 ms to 5 ms longer than for standard contactors.

3RT10 ...-X.40-0LA2

The contactors are energized via upstream control electronics which ensure the coil operating range of 0.7 to $1.25 \times U_s$ at an ambient temperature of $70 \text{ }^\circ\text{C}$. They are supplied as complete units with a built-on contactor control unit. A varistor is integrated for damping opening surges in the coil.

The possibility of mounting auxiliary switches is the same as that for equivalent standard contactors.

Mounting

At ambient temperatures up to $70 \text{ }^\circ\text{C}$, sizes S0 to S3 of these contactor versions are allowed to be mounted side by side.

Ambient temperature

The permissible ambient temperature for operation of the contactors (across the full operating range of the magnetic coil) is $-40 \text{ }^\circ\text{C}$ to $+70 \text{ }^\circ\text{C}$.

Uninterrupted duty at temperatures $> +60 \text{ }^\circ\text{C}$ reduces the mechanical endurance, the current-carrying capacity of the conducting paths and the switching frequency.

Dimensions

Because of the built-on contactor control unit, the height of the size S0 to S3 contactors increases by up to 34 mm (see "Dimensional Drawings").

3RT, 3RH, 3TB, 3TC, 3TH, 3TK Contactors for Special Applications

Contactors with Extended Operating Range $0.7 \dots 1.25 \times U_s$, for Railway Applications

3RT10 motor contactors, 5.5 ... 45 kW

Technical specifications

Contactors	Type		3RT10 17	3RT10 2.	3RT10 3.	3RT10 4.
Magnetic coil operating range	AC/DC		$0.7 \dots 1.25 \times U_s$			
Power consumption of the magnetic coils			For cold coil and $1.0 \times U_s$			
• Contactors with series resistor	- Closing	W	11	23	46	78
	- Closed	W	4	7	14	23
• Contactors without series resistor	- Closing	W	2.3	4.2	--	--
	- Closed	W	2.3	4.2	--	--
Upright mounting position			Standard version	3RT10 2.-3K.40: Special version required 3RT10 2.- 3K.44-0LA0: Special version required	--	--

All specifications and technical specifications not mentioned here are identical to those of the standard contactors.

Contactors			3RT10 2.	3RT10 3.	3RT10 4.
3RT10 contactors with contactor control unit					
Magnetic coil operating range			$0.7 \dots 1.25 \times U_s$		
Power consumption			For cold coil and $1.0 \times U_s$		
	• Closing	W	6	15	19
	• Closed	W	5.4	11	12
Upright mounting position			Special version required	--	--

All specifications and technical specifications not mentioned here are identical to those of the standard contactors.

3RT, 3RH, 3TB, 3TC, 3TH, 3TK Contactors for Special Applications

Contactors with Extended Operating Range $0.7 \dots 1.25 \times U_s$, for Railway Applications

3TB5 motor contactors, 55 ... 200 kW

Overview

EN 60947-4-1.

For requirements according to IEC 60077-1 and IEC 60077-2.

The contactors are finger-safe according to EN 50274. Terminal covers may have to be fitted onto the connecting bars, depending on the configuration with other devices.

Function

Control and auxiliary circuits

The magnetic coils of the contactors have an extended coil operating range from 0.7 to $1.25 \times U_s$ and are fitted as standard with varistors to provide protection against overvoltage. The opening delay is consequently 2 ms to 5 ms longer than for standard contactors.

The DC solenoid systems of the 3TB contactors must be modified (to holding excitation) by means of a series resistor.

This series resistor is supplied separately packed with the contactors. With types 3TB50, the series resistor must be attached onto the right-hand side of the auxiliary switch block by means of the enclosed mounting parts and sets of links provided.

With types 3TB52/54/56, the series resistor must be attached separately next to the contactors. One NC of the auxiliary contacts is required for the series resistor function. The selection

and ordering data show the number of additional, unassigned auxiliary contacts. It is not possible to extend the number of auxiliary contacts.

With the 3TB52 and larger contactors, the series resistor must be connected using an additional K2 reversing contactor (3RT13 17-1F.40). This contactor is automatically included in the scope of supply in the same packaging as the contactor.

All specifications and technical specifications not mentioned here are identical to those of the standard 3TB contactors.

Ambient temperature

The permissible ambient temperature for operation of the contactors (across the full operating range of the magnetic coil) is -50 to $+70$ °C. Uninterrupted duty at temperatures < -25 °C and $> +55$ °C reduces the mechanical endurance, the current-carrying capacity of the conducting paths and the switching frequency.

Mounting

At ambient temperatures > 55 °C, a distance of 10 mm must be observed if contactor relays and size 1 and 2 contactors are mounted side by side. There is no need to reduce the technical specifications.

Dimensions

Attaching resistors and varistors increases the width of the contactors (see "Dimensional Drawings").

Technical specifications

Contactors	Type	3TB50	3TB52	3TB54	3TB56
Magnetic coil operating range		0.8 ... $1.1 \times U_s$			
Power consumption of the magnetic coils		For cold coil and $1.0 \times U_s$			
• Closing	W	38	40	190	295
• Closed	W	20	21	43	59

3RT, 3RH, 3TB, 3TC, 3TH, 3TK Contactors for Special Applications

Contactors with Extended Operating Range $0.7 \dots 1.25 \times U_s$, for Railway Applications

3TC contactors for switching DC voltage, 2-pole

Overview

EN 60947-4-1.

For requirements according to IEC 60077-1 and IEC 60077-2.

The contactors are finger-safe according to EN 50274 (exception: series resistor). Terminal covers may have to be fitted onto the connecting bars, depending on the configuration with other devices.

Function

Control and auxiliary circuits

The magnetic coils of the contactors have an extended coil operating range from 0.7 to $1.25 \times U_s$ and are fitted as standard with varistors to provide protection against overvoltage. The opening delay is consequently 2 ms to 5 ms longer than for standard contactors.

The DC solenoid systems of the 3TC contactors must be modified (to holding excitation) by means of a series resistor.

This series resistor is supplied separately packed with the contactors. With types 3TC48, the series resistor must be attached onto the right-hand side of the auxiliary switch block by means of the enclosed mounting parts and sets of links provided, while in the case of the 3TC44 it must be mounted and wired between the contactor poles. With types 3TC52/56, the series resistor must be attached separately next to the contactors. One NC of the auxiliary contacts is required for the series resistor function.

The selection and ordering data show the number of additional, unassigned auxiliary contacts. It is not possible to extend the number of auxiliary contacts.

With the 3TC52 and larger contactors, the series resistor must be connected using an additional K2 reversing contactor (3RT13 17-1F.40). This contactor is automatically included in the scope of supply in the same packaging as the contactor.

All specifications and technical specifications not mentioned here are identical to those of the standard 3TC contactors.

Ambient temperature

The permissible ambient temperature for operation of the contactors (across the full operating range of the magnetic coil) is -50 to $+70$ °C. Uninterrupted duty at temperatures < -25 °C and $> +55$ °C reduces the mechanical endurance, the current-carrying capacity of the conducting paths and the switching frequency.

Mounting

At ambient temperatures > 55 °C, a distance of 10 mm must be observed if contactor relays and size 1 and 2 contactors are mounted side by side. There is no need to reduce the technical specifications.

Dimensions

Attaching resistors and varistors increases the width of the contactors (see "Dimensional Drawings").

Technical specifications

Contactors	Type	3TC44	3TC48	3TC52	3TC56
Magnetic coil operating range		$0.7 \dots 1.25 \times U_s$			
Power consumption of the magnetic coils		For cold coil and $1.0 \times U_s$			
• Closing	W	48	26	40	295
• Closed	W	13	14	21	59

3RT, 3RH, 3TB, 3TC, 3TH, 3TK Contactors for Special Applications

3TC Contactors for Switching DC Voltage

1- and 2-pole, 32 ... 400 A

Overview

3TC4 and 3TC5

EN 60947-4-1 (VDE 0660 Part 102).

The contactors are finger-safe according to EN 50274.

Terminal covers may have to be fitted onto the connecting bars, depending on the configuration with other devices.

The DC motor ratings given in the tables are applicable to the DC-3 and DC-5 utilization categories with two-pole switching of the load or with the two conducting paths of the contactor connected in series.

One contactor conducting path can switch full power up to 220 V. The ratings for higher voltages are available on request.

3TC7

EN 60947-4-1 (VDE 0660 Part 102).

The contactors are suitable for use in any climate. They are suitable for switching and controlling DC motors as well as all other DC loads. The electromagnetic excitation is designed for a particularly wide coil operating range.

It is between 0.7 or 0.8 to $1.2 \times U_s$.

3TC74 contactors can be used at up to 750 V/400 A and 50 Hz in AC-1 operation.

Technical specifications

Contactors	Type		3TC4 and 3TC7	3TC5
Rated data of the auxiliary contacts				
Rated insulation voltage U_i (degree of pollution 3)		V	690	
Continuous thermal current I_{th} = Rated operational current $I_o/AC-12$			10	10
AC load Rated operational current $I_o/AC-15/AC-14$ • For rated operational voltage U_e				
	24 V	A	10	10
	110 V	A	10	10
	125 V	A	10	10
	220 V	A	6	6
	230 V	A	5.6	5.6
	380 V	A	4	4
	400 V	A	3.6	3.6
	500 V	A	2.5	2.5
	660 V	A	2.5	2.5
	690 V	A	--	--
DC load Rated operational current $I_o/DC-12$ • For rated operational voltage U_e				
	24 V	A	10	10
	60 V	A	10	10
	110 V	A	3.2	8
	125 V	A	2.5	6
	220 V	A	0.9	2
	440 V	A	0.33	0.6
	600 V	A	0.22	0.4
Rated operational current $I_o/DC-13$ • For rated operational voltage U_e				
	24 V	A	10	10
	60 V	A	5	5
	110 V	A	1.14	2.4
	125 V	A	0.98	2.1
	220 V	A	0.48	1.1
	440 V	A	0.13	0.32
	600 V	A	0.07	0.21
Contactors	Type		3TC44 ... 3TC56	
Ⓢ and Ⓣ ratings of the auxiliary contacts				
Rated voltage		V AC, max.	600	
Switching capacity			A 600, P 600	

3RT, 3RH, 3TB, 3TC, 3TH, 3TK Contactors for Special Applications

3TC Contactors for Switching DC Voltage

1- and 2-pole, 32 ... 400 A

Contactors

Type

3TC44 ... 3TC78

Endurance of the main contacts

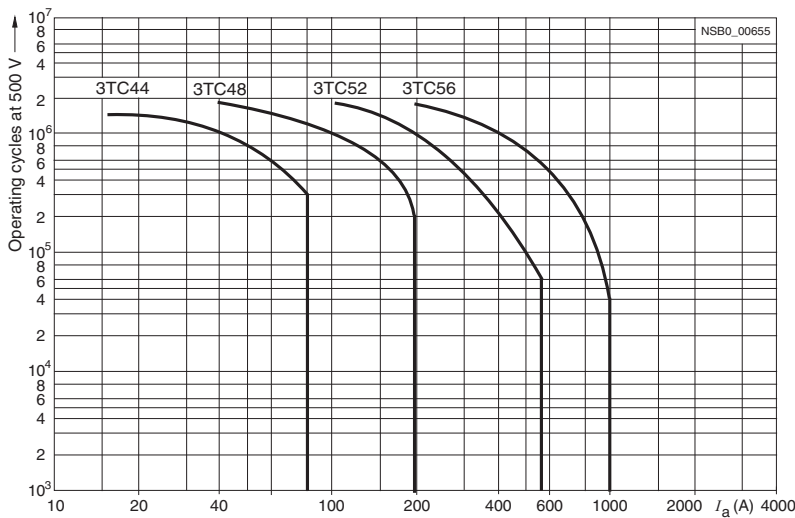

3TC44 to 3TC56 contactors

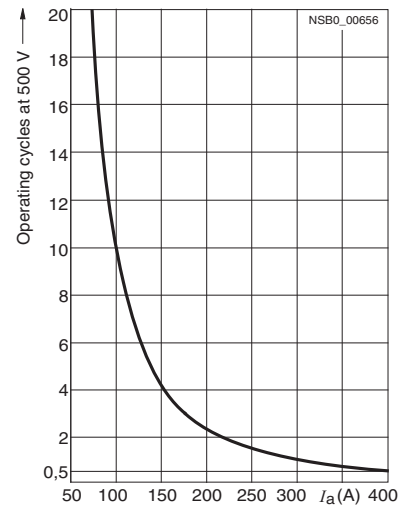

3TC74 and 3TC78 contactors

Diagram legend:
 I_a = Breaking current

Contactors

Type
Size3TC44
23TC48
43TC52
83TC56
12

General data

Permissible mounting position

The contactors are designed for operation on a vertical mounting surface.

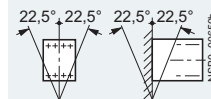

Mechanical endurance

Operating cycles

10 million

Electrical endurance

Operating cycles

1)

Rated insulation voltage U_i (degree of pollution 3)

V

800

1000

Protective separation between the coil and the main contacts acc. to EN 60947-1, Appendix N

V

Up to 300

Up to 660

Mirror contacts²⁾

A mirror contact is an auxiliary NC contact that cannot be closed simultaneously with a NO main contact.

Yes, acc. to EN 60947-4-1, Appendix F

Permissible ambient temperature

- During operation
- During storage

°C

-25 ... +55

°C

-50 ... +80

Degree of protection acc. to EN 60947-1, Appendix C

IP00/open, for AC operation, coil assembly IP40

Shock resistance

Rectangular pulse

g/ms

7.5/5 and 3.4/10

10/5 and 5/10

12/5 and 5.5/10

12/5 and 5.6/10

Short-circuit protection

Main circuit

Fuse links gL/gG

- Type of coordination "1"

A

50

160

250

400

LV HRC 3NA, DIAZED 5SB,

- Type of coordination "2"

A

35

63

80

250

NEOZED 5SE

Auxiliary circuit

(short-circuit current $I_k \geq 1$ kA)

- Fuse links, gL/gG

A

16

DIAZED 5SB, NEOZED 5SE

- Miniature circuit breaker with C characteristic

A

10

For the rated data of the auxiliary contacts see page 3/126.

1) See the endurance diagram above.

2) For 3TC44, one NC contact each must be connected in series for the right and left auxiliary switch block respectively.

3RT, 3RH, 3TB, 3TC, 3TH, 3TK Contactors for Special Applications

3TC Contactors for Switching DC Voltage

1- and 2-pole, 32 ... 400 A

Contactors	Type Size		3TC44 2	3TC48 4	3TC52 8	3TC56 12
Control						
Magnetic coil operating range			0.8 ... 1.1 x U_s			
Power consumption of the magnetic coils (for cold coil and 1.0 x U_s)						
• DC operation	- Closing = Closed	W	10	19	30	86
• AC operation, 50 Hz coil	- Closing	VA/p.f.	68/0.86	300/0.5	640/0.48	1780/0.3
	- Closed	VA/p.f.	10/0.29	26/0.24	46/0.23	121/0.22
• AC operation, 60 Hz coil	- Closing	VA/p.f.	95/0.79	365/0.45	730/0.38	2140/0.3
	- Closed	VA/p.f.	12/0.3	35/0.26	56/0.24	140/0.29
• AC operation, 50/60 Hz coil	- Closing at 50 Hz/60 Hz	VA/p.f.	79/73/0.83/0.78	--	--	--
	- Closed at 50 Hz/60 Hz	VA/p.f.	11/9/0.28/0.27	--	--	--
Operating times (at 0.8 ... 1.1 x U_s) Total break time = opening delay + Arcing time			(The values apply up to and including 20 % undervoltage, 10 % overvoltage, as well as when the coil is cold and warm)			
• DC operation	- Closing delay	ms	35 ... 190	90 ... 380	120 ... 400	110 ... 400
	- Opening delay ¹⁾	ms	10 ... 25	17 ... 28	22 ... 35	40 ... 110
• AC operation	- Closing delay	ms	10 ... 40	20 ... 50	20 ... 50	20 ... 50
	- Opening delay ¹⁾	ms	5 ... 25	5 ... 30	10 ... 30	10 ... 30
• Arcing time	- DC-1	ms	20			
	- DC-3/DC-5	ms	30			
Main circuit						
Load rating with DC						
Utilization category DC-1, switching resistive loads ($L/R \leq 1$ ms)						
• Rated operational currents I_e (at 55 °C)	Up to U_e 750 V	A	32	75	220	400
• Minimum conductor cross-section		mm ²	6	25	95	240
• Rated power at U_e	At 220 V	kW	7	16.5	48	88
	440 V	kW	14	33	97	176
	600 V	kW	19.2	45	132	240
	750 V	kW	24	56	165	300
Utilization category DC-3 and DC-5 Shunt-wound and series-wound motors ($L/R \leq 15$ ms)						
• Rated operational currents I_e (at 55 °C)	Up to 220 V	A	32	75	220	400
	440 V	A	29	75	220	400
	600 V	A	21	75	220	400
	750 V	A	7.5	75	170	400
• Rated power at U_e	At 110 V	kW	2.5	6.5	20	35
	220 V	kW	5	13	41	70
	440 V	kW	9	27	82	140
	600 V	kW	9	38	110	200
	750 V	kW	4	45	110	250
	Switching frequency					
Switching frequency z in operating cycles/hour						
AC/DC operation	• With resistive load DC-1 • For inductive load DC-3/DC-5	h ⁻¹ h ⁻¹	1500 750	1000 600		
Conductor cross-sections (1 or 2 conductors connectable)						
Main conductors:			 Screw terminals			
• Solid		mm ²	2 x (2.5 ... 10)	2 x (6 ... 16)	--	--
• Finely stranded with end sleeve		mm ²	2 x (1.5 ... 4)	--	--	--
• Stranded with cable lug		mm ²	2 x 16	2 x 35	2 x 120	2 x 150
• Pin-end connector to DIN 46231		mm ²	2 x (1 ... 6)	--	--	--
• Busbars		mm	--	15 x 2.5	25 x 4	2 x (25 x 3)
• Terminal screw		mm	M5	M6	M10	M10
Auxiliary conductors:						
• Solid		mm ²	2 x (1 ... 2.5)			
• Finely stranded with end sleeve		mm ²	2 x (0.75 ... 1.5)			

For the rated data of the auxiliary contacts see page 3/126.

¹⁾ The opening delay times can increase if the contactor coils are damped against voltage peaks. Only 3TC44 contactors are allowed to be fitted with diodes.

3RT, 3RH, 3TB, 3TC, 3TH, 3TK Contactors for Special Applications

3TC Contactors for Switching DC Voltage

1- and 2-pole, 32 ... 400 A

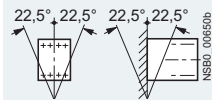
Contactors	Type	3TC74 1-pole contactors	3TC78 2-pole contactors
General data			
Permissible mounting position The contactors are designed for operation on a vertical mounting surface.			
Mechanical endurance	Operating cycles	30 million	
Electrical endurance	Operating cycles	1)	
Rated insulation voltage U_i (degree of pollution 3)	V	1500	
Rated impulse withstand voltage U_{imp}	kV	8	
Protective separation between the coil and the main contacts acc. to EN 60947-1, Appendix N	V	630	
Permissible ambient temperature	°C	-25 ... +55	
Degree of protection acc. to EN 60947-1 Appendix C		IP00/open	
Short-circuit protection			
Main circuit			
Fuse links, gL/gG	• Type of coordination "1":	A	630
LV HRC 3NA	• Type of coordination "2":	A	500
Auxiliary circuit (short-circuit current $I_k \geq 1$ kA)			
• Fuse links, gL/gG operational class DIAZED Type 5SB, NEOZED Type 5SE		A	16
• Miniature circuit breaker with C characteristic		A	10
Control			
Magnetic coil operating range			
• DC operation	24 V	0.8 ... 1.2 x U_s	
	> 24 V	0.7 ... 1.2 x U_s	
• AC operation	24 V	0.7 ... 1.15 x U_s	
	> 24 V	0.7 ... 1.14 x U_s	
Power consumption of the magnetic coils (when coil is cold and 1.0 x U_s)			
• DC operation	Closing = Closed	W	46
• AC operation, 50 Hz	Closing, Closed	VA	80/0.95
			92
			160/0.95
Operating times (Total break time = Opening delay + Arcing time)			
• AC and DC operation	- Closing delay	ms	60 ... 100
	- Opening delay	ms	20 ... 35
• Arcing time at 0.06 ... 4 x I_e		ms	40 ... 70
Main circuit			
Load rating with DC			
Utilization category DC-1, switching resistive loads ($L/R \leq 1$ ms)			
• Rated operational current $I_e/DC-1$ (at 55 °C)	A	500	500
• Minimum conductor cross-section	mm ²	2 x 150	2 x 150
• Rated power at			
	220 V	kW	110
	440 V	kW	220
	600 V	kW	300
	750 V	kW	375
	1200 V	kW	--
	1500 V	kW	--
			750
• Critical currents, without arc extinction			
	440 V	A	≤ 7
	600 V	A	≤ 13
	750 V	A	≤ 15
	≤ 800 V	A	--
	1200 V	A	≤ 13
	1500 V	A	≤ 15
Utilization categories DC-3 and DC-5, switching DC motors			
Permissible rated current for regenerative braking At 110 ... 600 V		A	400
Switching frequency			
Switching frequency z in operating cycles/hour			
• AC/DC operation	- With resistive load DC-1	h ⁻¹	750
	- For inductive load, DC-3/DC-5	h ⁻¹	500
			1000
			500
Conductor cross-section			
Main conductors:			
• Stranded with cable lug	mm ²	2 x ... 150	
• Busbars	mm	2 x (30 x 4)	
Auxiliary conductors:			
• Solid	mm ²	1 ... 2.5	
• Finely stranded with end sleeve	mm ²	0.75 ... 1.5	

For the rated data of the auxiliary contacts see page 3/126.

1) For endurance see page 3/127.

2) See selection table in Catalog LV 1.

3RH, 3TH Contactor Relays

3RH1 contactor relays, 4- and 8-pole

Overview

The SIRIUS generation of controls is a complete, modular system family, logically designed right down to the last detail, from the basic units to the accessories.

Contactor relays and coupling relays Size S00 with accessories

AC and DC operation

IEC 60947, EN 60947 (VDE 0660)

The 3RH1 contactor relays are suitable for use in any climate. They are finger-safe according to EN 50274.

The 3RH1 contactor relays have screw or Cage Clamp terminals. Four contacts are available in the basic unit.

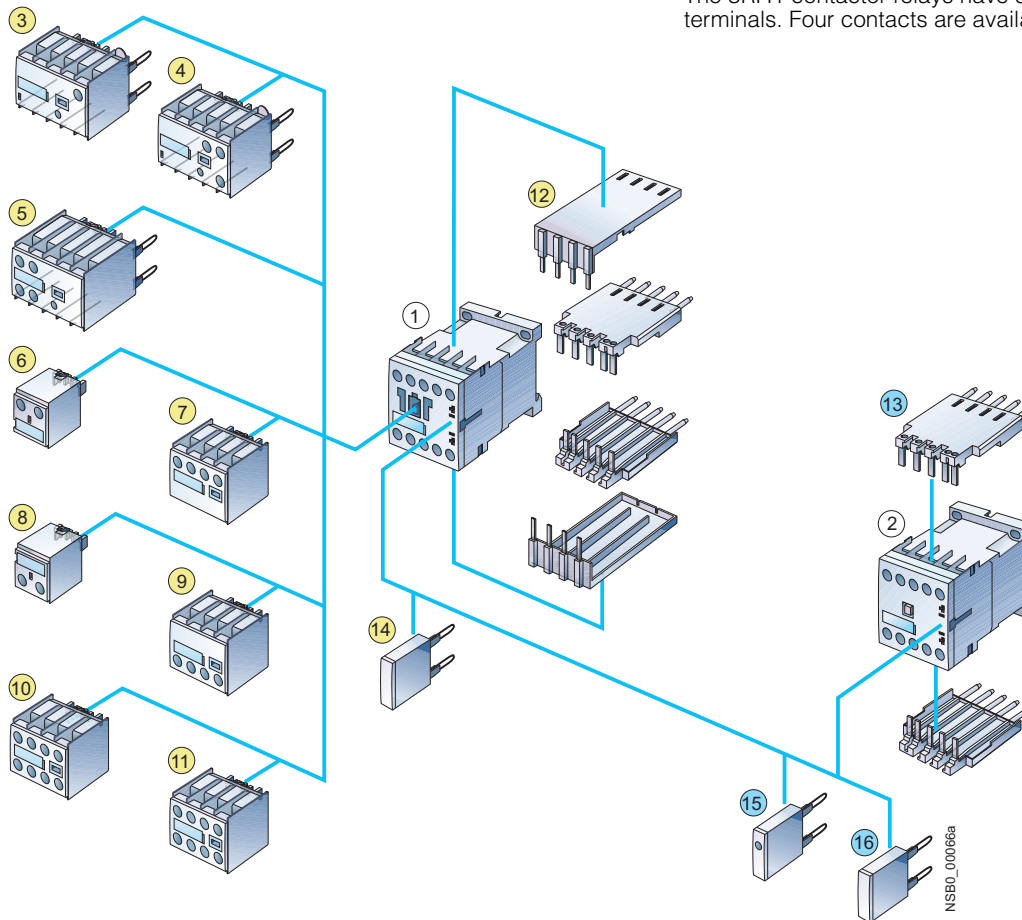

- ① Contactor relay
- ② Coupling relay for auxiliary circuits
- ③ Solid-state timing relay block, with ON-delay
- ④ Solid-state timing relay block, with OFF-delay
- ⑤ Auxiliary switch block, with solid-state time-delay (versions: ON or OFF-delay)
- ⑥ 1-pole auxiliary switch block, cable entry from above
- ⑦ 2-pole auxiliary switch block, cable entry from above
- ⑧ 1-pole auxiliary switch block, cable entry from below
- ⑨ 2-pole auxiliary switch block, cable entry from below
- ⑩ 4-pole auxiliary switch block (terminal designations according to EN 50011 or EN 50005)
- ⑪ 2-pole auxiliary switch block, standard version or solid-state time-delay version (terminal designations according to EN 50005)
- ⑫ Solder pin adapter for contactor relays with 4-pole auxiliary switch block
- ⑬ Solder pin adapter for contactor relays and coupling relays
- ⑭ Additional load module for increasing the permissible residual current
- ⑮ Surge suppressor with LED
- ⑯ Surge suppressor without LED

3RH1 contactor relays, 4- and 8-pole

Function**Contact reliability**

High contact stability at low voltages and currents, suitable for solid-state circuits with currents ≥ 1 mA at a voltage of 17 V.

Surge suppression

RC elements, varistors, diodes or diode assemblies (combination of a diode and a Zener diode) can be plugged onto all contactor relays from the front for damping opening surges in the coil. The plug-in direction is determined by a coding device.

Note:

The OFF-delay times of the NO contacts and the ON-delay times of the NC contacts increase if the contactor coils are damped against voltage peaks (noise suppression diode 6 to 10 times; diode assemblies 2 to 6 times, varistor +2 to 5 ms).

Integration**Auxiliary switch blocks**

The 3RH1 contactor relays can be expanded by up to four contacts by the addition of snap-on auxiliary switch blocks.

The auxiliary switch block can easily be snapped onto the front of the contactors. The auxiliary switch block has a centrally positioned release lever for disassembly.

The contactor relays with 4 contacts according to EN 50011, with the identification number 40E, can be extended with 80E to 44E auxiliary switch blocks to obtain contactor relays with 8 contacts according to EN 50011. The identification numbers 80E to 44E on the auxiliary switch blocks apply to the complete contactors. These auxiliary switch blocks (3RH19 11-1GA ..) cannot be combined with contactor relays with identification numbers 31E and 22E; they are coded.

All contactor relays with 4 contacts according to EN 50011, identification numbers 40E to 22E, can be extended with auxiliary switch blocks 40 to 02 to obtain contactor relays with 6 or 8 contacts in accordance with EN 50005. The identification numbers on the auxiliary switch blocks apply only to the attached auxiliary switch blocks.

In addition, fully mounted 3RH12 8-pole contactor relays are available; the mounted 4-pole auxiliary switch block in the 2nd tier is not removable.

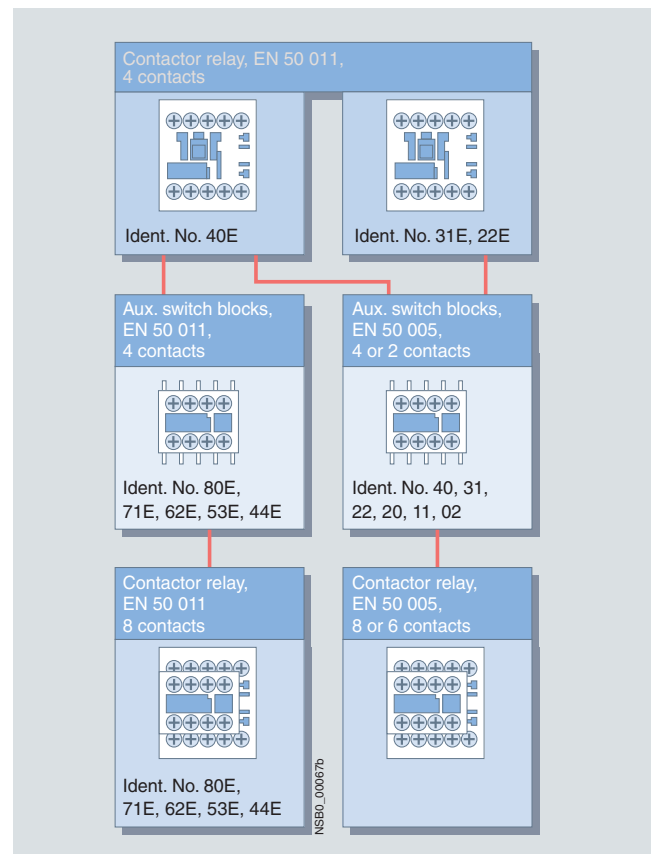

The terminal designations comply with EN 50011. These versions are built in accordance with special Swiss regulations (SUVA) and are distinguished externally by a red labeling plate.



3RH, 3TH Contactor Relays

3RH1 contactor relays, 4- and 8-pole

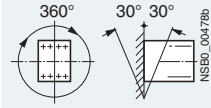
Technical specifications

Contactor	Type Size	3RH1 S00
Permissible mounting position		
The contactors are designed for operation on a vertical mounting surface.	• AC and DC operation	
Upright mounting position (only for 3RH11/3RH12/3RH14)	• AC operation	
	• DC operation	Special version required Standard version (for coupling relays and contactor relays with extended operating range 3RH11 22-2K.40, please ask)

Positively-driven operation of contacts in contactor relays

3RH1:

Yes, in the basic unit and the auxiliary switch block as well as between the basic unit and the snap-on auxiliary switch block (removable) acc. to:

- ZH 1/457
- EN 60947-5-1, Appendix L

3RH12:

Yes, in the basic unit and the auxiliary switch block as well as between the basic unit and the snap-on auxiliary switch block (fixed) acc. to:

- ZH 1/457
- EN 60947-5-1, Appendix L
- SUVA

Note:

3RH19 11- NF solid-state compatible auxiliary switch blocks have no positively-driven contacts.

Contact reliability

Contact reliability at 17 V, 1 mA acc. to EN 60947-5-4

Explanations:

There is positively-driven operation if it is ensured that the NC and NO contacts cannot be closed at the same time.

ZH1/457

Safety rules for control units on power-operated presses in the metal-working industry.

EN 60947-5-1, Appendix L

Low-voltage controlgear, control equipment, and switching elements. Special requirements for positively-driven contacts

SUVA

Accident prevention regulations of the "Schweizer Unfallverhütungsanstalt" (Swiss Institute for Accident Insurance)

Frequency of contact faults $<10^{-8}$, i. e. <1 fault per 100 million operating cycles

Contact endurance for AC-15/AC-14 and DC-13 utilization categories

The contact endurance is mainly dependent on the breaking current. It is assumed that the operating mechanisms are switched randomly, i. e. not synchronized with the phase angle of the supply system. If magnetic circuits other than the contactor coil systems or solenoid valves are present, e.g. magnetic brakes, protective measures for the load circuits are necessary.

RC elements and freewheel diodes would be suitable as protective measures.

The characteristic curves apply to:

- 3RH11, 3RH12 contactor relays
- 3RH14 latched contactor relays
- 3RH19 11 auxiliary switch blocks.

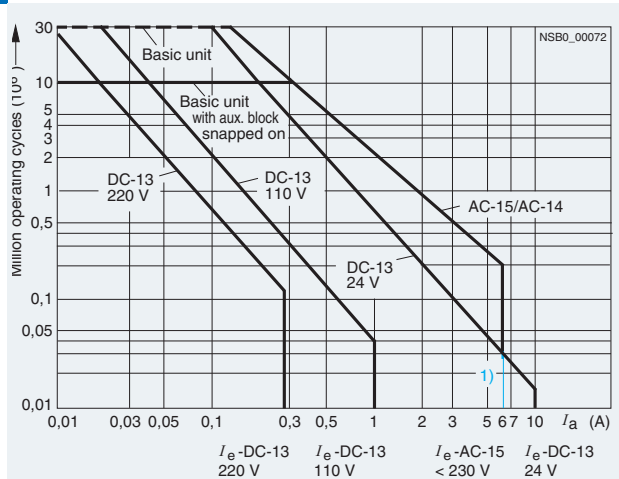

Diagram legend:

I_a = Breaking current

I_e = Rated operational current

1) Snap-on auxiliary switch blocks: I_e /DC-13 max. 6 A.

3RH, 3TH Contactor Relays

3RH1 contactor relays, 4- and 8-pole

Contactors	Type Size	3RH11, 3RH12 S00	3RH14 S00
Ⓢ and Ⓛ ratings			
Basic units and auxiliary switch blocks			
• Rated control supply voltage	V AC	Max. 600	
• Rated voltage	V AC	600	
• Switching capacity		A 600, Q 600	
• Uninterrupted current at 240 V AC	A	10	
General data			
Mechanical endurance	• Basic units	Operating cycles	30 million
	• Basic unit with snap-on auxiliary switch block	Operating cycles	10 million
	• Solid-state compatible auxiliary switch block	Operating cycles	5 million
Rated insulation voltage U_i (degree of pollution 3)	V	690	
Rated impulse withstand voltage U_{imp}	kV	6	
Protective separation between the coil and the contacts in the basic unit acc. to EN 60947-1, Appendix N	V	400	
Permissible ambient temperature	• During operation • During storage	°C	-25 ... +60 -55 ... +80
Degree of protection acc. to EN 60947-1, Appendix C			IP20, coil assembly IP40
Touch protection acc. to EN 50274			Finger-safe
Shock resistance			
• Rectangular pulse	AC/DC operation	g/ms	10/5 and 5/10
• Sine pulse	AC/DC operation	g/ms	15/5 and 8/10
Conductor cross-sections (1 or 2 conductors connectable)			
Auxiliary conductor and coil terminals			⊕ Screw terminals
• Solid	mm ²		2 x (0.5 ... 1.5) 2 x (0.75 ... 2.5) acc. to IEC 60947; max. 2 x (1 ... 4)
• Finely stranded with end sleeve	mm ²		2 x (0.5 ... 1.5) 2 x (0.75 ... 2.5)
• AWG cables, solid or stranded	AWG		2 x (20 ... 16) 2 x (18 ... 14) 1 x 12
• Terminal screws		M3	
- Tightening torque	Nm		0.8 ... 1.2 (7 ... 10.3 lb.in)
Auxiliary conductor and coil terminals			⊖ Cage Clamp terminals
• Solid	mm ²		2 x (0.25 ... 2.5)
• Finely stranded with end sleeve	mm ²		2 x (0.25 ... 1.5)
• Finely stranded without end sleeve	mm ²		2 x (0.25 ... 2.5)
• AWG cables, solid or stranded	AWG		2 x (24 ... 14)
Short-circuit protection			
(weld-free protection at $I_k \geq 1$ kA)			
• Fuse links, gL/gG operational class			
- DIAZED, Type 5SB	A		10
- NEOZED, Type 5SE	A		10
• Or miniature circuit breakers with C characteristic (short-circuit current $I_k < 400$ A)	A		6

For corresponding 8WA2 803/8WA2 804 opening tool, see Catalog LV 1.

An "insulation stop" must be used for conductor cross-sections ≤ 1 mm², see Catalog LV 1.

Note:

Maximum external diameter of the conductor insulation: 3.6 mm.

3RH, 3TH Contactor Relays

3RH1 contactor relays, 4- and 8-pole

Contactor	Type Size	3RH1- S00	
Control			
Magnetic coil operating range			
• AC operation		At 50 Hz At 60 Hz	0.8 ... 1.1 x U_s 0.85 ... 1.1 x U_s
• DC operation		At +50 °C At +60 °C	0.8 ... 1.1 x U_s 0.85 ... 1.1 x U_s
Power consumption of the magnetic coils (when coil is cold and 1.0 x U_s)			
• AC operation, 50 Hz	- Closing - Closed	VA/p.f. VA/p.f.	27/0.8 4.6/0.27
• AC operation, 60 Hz	- Closing - Closed	VA/p.f. VA/p.f.	24/0.75 3.5/0.27
• DC operation	- Closing = Closed	W	3.2
Permissible residual current of the electronics (with 0 signal)			
	• For AC operation ¹⁾ • For DC operation		< 3 mA x (230 V/ U_s) < 10 mA x (24 V/ U_s)
Operating times²⁾ (Total break time = OFF-delay + Arcing time)			
<u>AC operation</u> Values apply with coil in cold state and at operating temperature for operating range			
• Closing			
- ON-delay of NO contact	0.8 ... 1.1 x U_s 1.0 x U_s 3RH14 minimum operating time	ms ms ms	8 ... 35 10 ... 25 ≥ 35
- OFF-delay of NC contact	0.8 ... 1.1 x U_s 1.0 x U_s	ms ms	6 ... 20 7 ... 20
• Opening			
- OFF-delay of NO contact	0.8 ... 1.1 x U_s 1.0 x U_s 3RH14 minimum operating time	ms ms ms	4 ... 30 5 ... 30 ≥ 30
- ON-delay of NC contact	0.8 ... 1.1 x U_s 1.0 x U_s	ms ms	5 ... 30 7 ... 20
<u>DC operation</u>			
• Closing			
- ON-delay of NO contact	0.8 ... 1.1 x U_s 1.0 x U_s 3RH14 minimum operating time	ms ms ms	25 ... 100 30 ... 50 ≥ 100
- OFF-delay of NC contact	0.8 ... 1.1 x U_s 1.0 x U_s	ms ms	20 ... 90 25 ... 45
• Opening			
- OFF-delay of NO contact	0.8 ... 1.1 x U_s 1.0 x U_s 3RH14 minimum operating time	ms ms ms	7 ... 10 7 ... 9 ≥ 30
- ON-delay of NC contact	0.8 ... 1.1 x U_s 1.0 x U_s	ms ms	13 ... 16 13 ... 15
• Arcing time		ms	10 ... 15
Dependence of the switching frequency z' on the operational current I' and operational voltage U' : $z' = z \cdot (I_0/I') \cdot (400 \text{ V}/U')^{1.5} \cdot 1/\text{hy}$			

¹⁾ The 3RT19 16-1GA00 additional load module is recommended for higher residual currents, see Catalog LV 1.

²⁾ The OFF-delay of the NO contact and the ON-delay of the NC contact are increased if the contactor coils are attenuated against voltage peaks (noise suppression diode 6 to 10 times; diode assemblies 2 to 6 times, varistor +2 to 5 ms).

3RH1 contactor relays, 4- and 8-pole

Contactors	Type Size	3RH1. S00	
Load side			
Rated operational currents I_e			
AC-12		A	10
AC-15/AC-14	Up to 230 V	A	6
For rated operational voltage U_s	400 V	A	3
	500 V	A	2
	690 V	A	1
DC-12			
For rated operational voltage U_s			
• 1 conducting path	24 V	A	10
	60 V	A	6
	110 V	A	3
	220 V	A	1
	440 V	A	0.3
	600 V	A	0.15
• 2 conducting paths in series	24 V	A	10
	60 V	A	10
	110 V	A	4
	220 V	A	2
	440 V	A	1.3
	600 V	A	0.65
• 3 conducting paths in series	24 V	A	10
	60 V	A	10
	110 V	A	10
	220 V	A	3.6
	440 V	A	2.5
	600 V	A	1.8
DC-13			
For rated operational voltage U_s			
• 1 conducting path	24 V	A	10 ¹⁾
	60 V	A	2
	110 V	A	1
	220 V	A	0.3
	440 V	A	0.14
	600 V	A	0.1
• 2 conducting paths in series	24 V	A	10
	60 V	A	3.5
	110 V	A	1.3
	220 V	A	0.9
	440 V	A	0.2
	600 V	A	0.1
• 3 conducting paths in series	24 V	A	10
	60 V	A	4.7
	110 V	A	3
	220 V	A	1.2
	440 V	A	0.5
	600 V	A	0.26
Switching frequency z			
• In operating cycles/h during normal duty for utilization category	AC-12/DC-12	h ⁻¹	1000
	AC-15/AC-14	h ⁻¹	1000
	DC-13	h ⁻¹	1000
• No-load switching frequency		h ⁻¹	10000
Dependence of the switching frequency z' on the operational current I' and operational voltage U' : $z' = z \cdot (I_e/I') \cdot (400 \text{ V}/U')^{1.5} \cdot 1/\text{h}$			

¹⁾ Snap-on auxiliary switch blocks: 6 A.

3RH, 3TH Contactor Relays

3RH14 latched contactor relays, 4-pole

Overview

AC and DC operation

IEC 60947, EN 60947 (VDE 0660).

The terminal designations comply with EN 50011.

The contactor coil and the coil of the release solenoid are both designed for uninterrupted duty.

The number of auxiliary contacts can be extended by means of auxiliary switch blocks (up to 4 poles).

RC elements, varistors diodes or diode assemblies can be fitted to both coils from the front for damping opening surges in the coil.

The contactor relay can also be switched on and released manually ([for minimum actuating times, see page 3/134](#)).

Overview**AC and DC operation**

IEC 60947 and EN 60947 (VDE 0660).

The 3TH42/3TH43 contactor relays are suitable for use in any climate. They are finger-safe according to EN 50274.

Terminal designations according to EN 50011

In terms of their terminal designations, identification numbers and identification letters, the 3TH42/3TH43 contactor relays conform to the standard EN 50011 for "Specific contactor relays".

Function**Contact reliability**

High contact stability at low voltages and currents thanks to the use of moving double-break contacts, suitable for solid-state circuits with currents ≥ 1 mA for voltages at 17 V.

Make-before-break contacting

The 3TH42/3TH43 contactor relays are available in versions with make-before-break contacting (make-before-break between 1 NO and 1 NC).

The make-before-break time is approximately 1 ms. This is not sufficient to cause another contactor to close. If the make-before-break conducting paths are connected in series, a fleeting contact element is created; the wiping time is approximately 1 ms.

Surge suppression

The 3TH42/3TH43 contactors can be equipped with RC elements, varistors, diodes or diode assemblies (combination of a diode and a Zener diode) for damping opening surges. The surge suppressors can be mounted directly on the coil (see "Accessories").

Note:

The OFF-delay times of the NO contacts and the ON-delay times of the NC contacts increase if the contactor coils are damped against voltage peaks (noise suppression diode 6 to 10 times; diode assembly 2 to 6 times, varistor +2 to 5 ms).

Technical specifications

Contactors	Type	3TH42/3TH43
Permissible mounting position		
The contactors are designed for operation on a vertical mounting surface.	• AC operation	
	• DC operation	
Upright mounting position	• AC and DC operation	<p>Special version required</p>

Positively-driven operation in contactor relays with 8 and 10 contacts**3TH42/3TH43:**

Yes, the contactor relays comply with the conditions for positively-driven operation acc. to:

- ZH 1/457
- EN 60947-5-1, Appendix L
- SUVA

Explanations:

There is positively-driven operation if it is ensured that the NC and NO contacts cannot be closed at the same time.

ZH1/457

Safety rules for control units on power-operated presses in the metal-working industry.

EN 60947-5-1, Appendix L

Low-voltage controlgear, control equipment, and switching elements. Special requirements for positively-driven contacts

SUVA

Accident prevention regulations of the "Schweizer Unfallverhütungsanstalt" (Swiss Institute for Accident Insurance)

3RH, 3TH Contactor Relays

3TH4 contactor relays, 8- and 10-pole

Contactors

Type

3TH42/3TH43

Contact endurance for AC-15/AC-14 and DC-13 utilization categories

The contact endurance is mainly dependent on the breaking current. It is assumed that the operating mechanisms are switched randomly, i. e. not synchronized with the phase angle of the supply system. If magnetic circuits other than the contactor coil systems or solenoid valves are present, e.g. magnetic brakes, protective measures for the load circuits are necessary. RC elements and freewheel diodes would be suitable as protective measures.

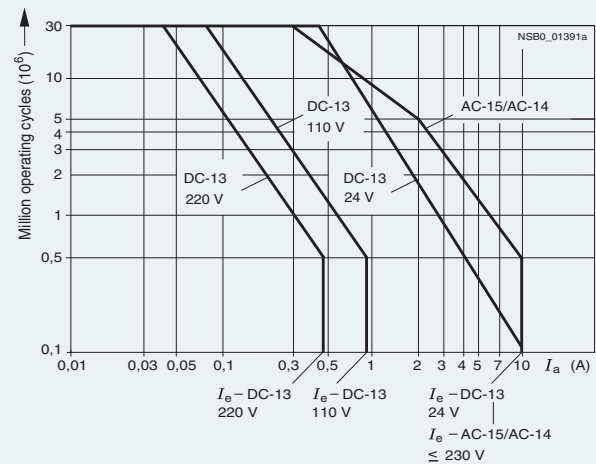

Ⓢ and Ⓜ ratings

Basic units

Rated control supply voltage U_s

Max. 600 V AC, 230 V DC (acc. to UL 240 V DC)

Rated voltage

600 V AC, 600 V DC

Switching capacity

A 600, P 600

General data

Mechanical endurance	Basic units	Operating cycles	30 million
Rated insulation voltage U_i (degree of pollution 3)		V	690
Rated impulse withstand voltage U_{imp}		kV	8
Protective separation between the coil and the main contacts acc. to EN 60947-1, Appendix N		V	Up to 500
Permissible ambient temperature	<ul style="list-style-type: none"> • During operation • During storage 	°C	-25 ... +55 -55 ... +80
Degree of protection acc. to EN 60947-1, Appendix C			IP20
Shock resistance			
• Rectangular pulse	- AC operation	g/ms	7.7/5 and 4.4/10
	- DC operation	g/ms	9.3/5 and 5.4/10
• Sine pulse	- AC operation	g/ms	12/5 and 6.8/10
	- DC operation	g/ms	14.7/5 and 8.5/10

Conductor cross-sections

- Solid
- Finely stranded with end sleeve
- Terminal screw

mm²
mm²

Ⓢ Screw terminals

2 x (0.5 ... 1)¹⁾; 2 x (1 ... 2.5)¹⁾; 1 x 4
 2 x (0.75 ... 2.5)
 M3.5

Short-circuit protection

(weld-free protection at $I_k \geq 1$ kA)

• Fuse links, gL/gG operational class	- LV HRC Type 3NA	A	16
	- DIAZED Type 5SB	A	16
	- NEOZED Type 5SE, quick	A	20
• Miniature circuit breaker	- C Characteristic	A	16
	- B Characteristic	A	16

¹⁾ If two different conductor cross-sections are connected to one clamping point, both cross-sections must lie in the range specified. If identical cross-sections are used, this restriction does not apply.

Contactors	Type	3TH42/3TH43	
Control			
Magnetic coil operating range			
AC operation			0.8 ... 1.1 x U_s ¹⁾
DC operation (except 24 V)			0.8 ... 1.1 x U_s
• At 24 V DC			0.8 ... 1.2 x U_s
Power consumption of the magnetic coils (when coil is cold and 1.0 x U_s)			
AC operation, 50 Hz, standard version			
• Closing	VA/p.f.	68/0.82	
• Closed	VA/p.f.	10/0.29	
AC operation, 50/60 Hz, standard version			
• Closing, 50 Hz	VA/p.f.	77/0.81	
• Closed, 50 Hz	VA/p.f.	11/0.28	
• Closing, 60 Hz	VA/p.f.	71/0.75	
• Closed, 60 Hz	VA/p.f.	9/0.27	
AC operation, 50 Hz, USA/Canada			
• Closing	VA/p.f.	68/0.82	
• Closed	VA/p.f.	10/0.29	
AC operation, 60 Hz, USA/Canada			
• Closing	VA/p.f.	75/0.76	
• Closed	VA/p.f.	9.4/0.29 ... 0.3	
AC operation, 50 Hz, standard version			
• Closing	VA/p.f.	80/0.8	
• Closed	VA/p.f.	10.7/0.29	
AC operation, 60 Hz, standard version			
• Closing	VA/p.f.	75 ... 90/0.73	
• Closed	VA/p.f.	8.5 ... 10.7/0.29 ... 0.3	
DC operation up to 250 V	Closing = Closed	W	6.2
Permissible residual current of the electronics (with 0 signal)			
For AC operation			$\leq 8 \text{ mA} \times (220 \text{ V}/U_s)$
For DC operation			$\leq 1.25 \text{ mA} \times (220 \text{ V}/U_s)$
Operating times²⁾			
Total break time = OFF-delay + arcing time (the values apply up to and including 20 % undervoltage, 10 % overvoltage, and with the coil in the cold state and at operating temperature)			
<u>AC operation</u>			
Closing			
• ON-delay NO	ms	8 ... 35	
• OFF-delay NC	ms	6 ... 20	
Opening			
• OFF-delay NO	ms	4 ... 18	
• ON-delay NC	ms	5 ... 30	
Arcing time	ms	10	
<u>DC operation</u>			
Closing			
• ON-delay NO	ms	20 ... 170	
• OFF-delay NC	ms	18 ... 110	
Opening			
• OFF-delay NO	ms	10 ... 25	
• ON-delay NC	ms	15 ... 30	
Arcing time	ms	10	
Operating times²⁾ at 1.0 x U_s			
<u>AC operation</u>			
Closing			
• ON-delay NO	ms	10 ... 25	
• OFF-delay NC	ms	7 ... 20	
Opening			
• OFF-delay NO	ms	5 ... 18	
• ON-delay NC	ms	7 ... 20	
<u>DC operation</u>			
Closing			
• ON-delay NO	ms	30 ... 70	
• OFF-delay NC	ms	28 ... 65	
Opening			
• OFF-delay NO	ms	10 ... 20	
• ON-delay NC	ms	15 ... 25	

¹⁾ Coils for USA, Canada and Japan: 0.85 ... 1.1 U_s at 60 Hz.

²⁾ The OFF-delay of the NO contact and the ON-delay of the NC contact are increased if the contactor coils are attenuated against voltage peaks (noise suppression diode 6 to 9 times; diode assemblies 2 to 6 times, varistor +2 to 5 ms).

3RH, 3TH Contactor Relays

3TH4 contactor relays, 8- and 10-pole

Contactor	Type	3TH42/3TH43	
Load side			
Rated operational currents I_e			
AC-12	A		16
AC-15/AC-14 for rated operational voltage U_e			
	230 V	A	10
	400 V	A	6
	500 V	A	4
	690 V	A	2
DC-12, for rated operational voltage U_e			
• 1 conducting path			
	Up to 48 V	A	10
	110 V	A	2.1
	220 V	A	0.8
	440 V	A	0.6
	600 V	A	0.6
• 2 conducting paths in series			
	Up to 48 V	A	10
	110 V	A	10
	220 V	A	1.6
	440 V	A	0.8
	600 V	A	0.7
• 3 conducting paths in series			
	Up to 48 V	A	10
	110 V	A	10
	220 V	A	10
	440 V	A	1.3
	600 V	A	1
DC-13, for rated operational voltage U_e			
• 1 conducting path			
	24 V	A	10
	48 V	A	5
	110 V	A	1
	220 V	A	0.45
	440 V	A	0.25
	600 V	A	0.2
• 2 conducting paths in series			
	24 V	A	10
	48 V	A	10
	110 V	A	2.5
	220 V	A	0.75
	440 V	A	0.5
	600 V	A	0.4
• 3 conducting paths in series			
	24 V	A	10
	48 V	A	10
	110 V	A	10
	220 V	A	2
	440 V	A	0.9
	600 V	A	0.8
Rated power of induction motors			
Acc. to utilization category AC-2 and AC-3, 50 Hz			
	230/220 V	kW	2.4
	400/380 V	kW	4
	500 V	kW	4
	690/660 V	kW	4
Switching frequency z^1			
Operating cycles per hour during normal duty for utilization category			
	AC-12/DC-12	h ⁻¹	1000
	AC-2	h ⁻¹	500
	AC-3	h ⁻¹	1000
	AC-15/AC-14	h ⁻¹	3600
	DC-13	h ⁻¹	3600
	No-load switching frequency	h ⁻¹	10000

¹⁾ Dependence of the switching frequency z' on the operational current I' and operational voltage U' : $z' = z \cdot (I_e/I') \cdot (400 \text{ V}/U')^{1.5} \cdot 1/\text{h}$.

3TH2 contactor relays, 4- and 8-pole

Overview**AC and DC operation**

IEC 60947 (VDE 0660).

The terminal designations comply with EN 50011.

3TH2 contactor relays

The 3TH2 contactor relays are suitable for use in any climate. The contactor relays with screw terminals are finger-safe according to EN 50274.

3TH27 latched contactor relays

The contactor coil and the coil of the release solenoid are both designed for uninterrupted duty.

RC elements, varistors diodes or diode assemblies can be fitted to both coils from the front for damping opening surges in the coil.

The contactor relay can also be switched on and released manually.

Design**3TH2 contactor relays****Version**

The 3TH20 contactors with 4 auxiliary contacts are available with SIGUT screw terminals, 6.3 mm x 0.8 mm flat connectors and solder pin connections.

The contactors with 6.3 mm x 0.8 mm flat connectors can be used in the plug-in base with solder pin connections for printed circuit boards. The contactor relays are coded and the plug-in base is codable in order to ensure non-interchangeability.

The 3TH22 contactor relays with 8 integrated contacts are available with screw terminals. The terminal designations are according to EN 50011.

Contact reliability

High contact stability at low voltages and currents, suitable for solid-state circuits with currents ≥ 1 mA at a voltage of 17 V and higher.

Auxiliary switch blocks

The contactor relays with 4 contacts with screw terminals relays can be expanded by up to four contacts by the addition of snap-on auxiliary switch blocks.

A cover (with unit labeling plate) must be removed from the front of the contactor for this purpose. The auxiliary switch block is then easy to mount. The auxiliary switch blocks can be removed again by unlocking them with a laterally arranged slide.

The contactor relays with screw terminals with 4 contacts according to EN 50011, with the identification number 40E, can be extended with 80E, 71E, 62E, 53E or 44E auxiliary switch blocks to obtain contactor relays with 8 contacts according to EN 50011. The identification numbers 80E, 71E, 62E, 53E or 44E on the coded auxiliary switch blocks apply to the complete contactors (see graphic on the right). These auxiliary switch blocks cannot be combined with contactor relays with identification number 31E and 33E.

All contactor relays with screw terminals with 4 contacts according to EN 50011, identification number 40E, 31E or 22E, can be extended with auxiliary switch blocks with identification number 40, 31, 22, 20, 11 or 02 to obtain contactor relays with 6 or 8 contacts according to EN 50005. The identification numbers on the auxiliary switch blocks apply only to the attached auxiliary switch blocks (see the graphic on the right).

3TH20 ...-0 contactor relays

Terminal designations according to EN 50011 and EN 50005

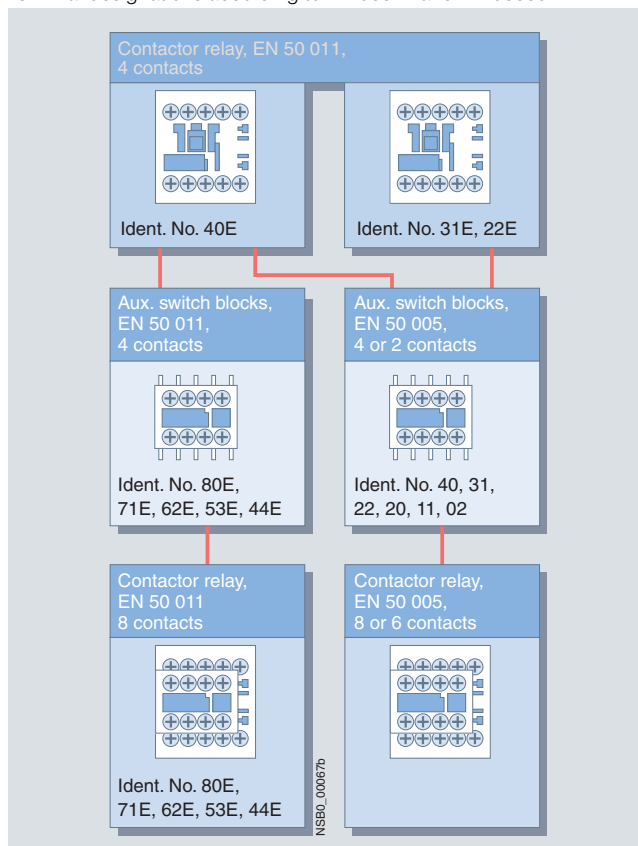
**Surge suppression**

RC elements, varistors, diodes or diode assemblies (combination of a diode and a Zener diode for short break times) can be plugged onto all contactors and auxiliary switch blocks with screw terminals from the front in order to damp opening surges in the coil. The unit labeling plate must be removed for this purpose.

It can be snapped onto the attached surge suppressor.

Residual current

The 3TX4 490-1J additional load module (see "Accessories") can be used by programmable logic controllers to increase the permissible residual current and to limit the residual voltage of semiconductor outputs.

This module ensures the safe opening of 3TH2/3TF2 contactors with direct control through 230 V AC semiconductor outputs. It is accommodated in the same enclosure as the 3TX4 490-3. surge suppressors and can be plugged into the contactor.

3RH, 3TH Contactor Relays

3TH2 contactor relays, 4- and 8-pole

Technical specifications

Contactor relays Type **3TH2**

Contact endurance for AC-15/AC-14 and DC-13 utilization categories

The contact endurance is mainly dependent on the breaking current. It is assumed that the operating mechanisms are switched randomly, i. e. not synchronized with the phase angle of the supply system.

If magnetic circuits other than the contactor coil systems or solenoid valves are present, e.g. magnetic brakes, protective measures for the load circuits are necessary. RC elements and freewheel diodes would be suitable as protective measures. Diagram legend:

I_e = Rated operational current

I_a = Breaking current

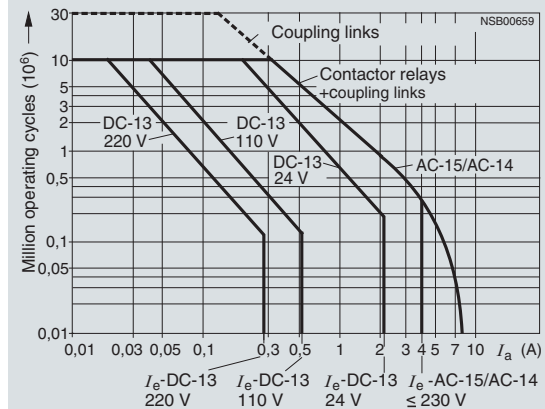

Type	Contactor relays		Auxiliary switch block
	3TH20 ..-....	3TH22 ..-....	3TX4
General data			
Permissible mounting position	AC and DC operation		Any
Mechanical endurance	<ul style="list-style-type: none"> • AC operation • DC operation 	Operating cycles	10 million 30 million
Rated insulation voltage U_i (degree of pollution 3)			
• Screw terminals	V	690	500
• Flat connector 6.3 mm x 0.8 mm	V	500	--
• Solder pin connections	V	500	--
Rated impulse withstand voltage U_{imp} (degree of pollution 3)			
• Screw terminals	kV	8	6
• Flat connector 6.3 mm x 0.8 mm	kV	6	--
• Solder pin connections	kV	6	--
Protective separation between coil and contacts (acc. to EN 61140)	V	Up to 300	
Positively-driven operation of contacts in contactor relays			
3TH20: Yes , in the basic unit and the auxiliary switch block as well as between the basic unit and the snap-on auxiliary switch block (removable) acc. to: • ZH 1/457 • EN 60947-5-1, Appendix L	Explanations: There is positively-driven operation if it is ensured that the NC and NO contacts cannot be closed at the same time. ZH1/457 Safety rules for control units on power-operated presses in the metal-working industry. EN 60947-5-1, Appendix L Low-voltage controlgear, control equipment, and switching elements. Special requirements for positively-driven contacts SUVA Accident prevention regulations of the "Schweizer Unfallverhütungsanstalt" (Swiss Institute for Accident Insurance)		
3TH22: Yes , in the basic unit and the auxiliary switch block as well as between the basic unit and the snap-on auxiliary switch block (fixed) acc. to: • ZH 1/457 • EN 60947-5-1, Appendix L • SUVA			
Permissible ambient temperature ¹⁾	<ul style="list-style-type: none"> • During operation • During storage 	°C	-25 ... +55 -55 ... +80
Degree of protection acc. to EN 60947-1 Appendix C	IP00 open IP20 for screw terminals IP40 coil assembly		
Touch protection acc. to EN 50274	Finger-safe for screw terminals		
Shock resistance			
• Rectangular pulse	- AC operation - DC operation	g/ms g/ms	7/5 and 4/10 10/5 and 6/10
• Sine pulse	- AC operation - DC operation	g/ms g/ms	9/5 and 6/10 13/5 and 8/10
Conductor cross-sections	2)		

1) Applies to 50/60 Hz coil
Operating range at 60 Hz: $0.85 \dots 1.1 \times U_s$;
at 50 Hz, $1.1 \times U_s$, side-by-side mounting and 100 % ON period the max. ambient temperature is +40 °C.

2) For conductor cross-sections see page 3/144.

3TH2 contactor relays, 4- and 8-pole



Contactor relays	Type	3TH2	
Short-circuit protection			
LV HRC 3NA, DIAZED 5SB, NEOZED 5SE Weld-free protection at $I_k \geq 1$ kA	A	6	
Control			
Magnetic coil operating range¹⁾		$0.8 \dots 1.1 \times U_s$	
Power consumption of the magnetic coils (when coil is cold and $1.0 \times U_s$)			
• AC operation, 50 Hz	Closing P.f. Closed P.f.	VA	15 0.41 6.8 0.42
• AC operation, 60 Hz	Closing P.f. Closed P.f.	VA	14.4 0.36 6.1 0.46
• AC operation, 50/60 Hz ¹⁾	Closing P.f. Closed P.f.	VA	16.5/13.2 0.43/0.38 8.0/5.4 0.48/0.42
• DC operation	Closing = Closed	W	3
Permissible residual current of the electronics (with 0 signal)			
	AC operation	mA	$\leq 3 \times (220 \text{ V}/U_s)$
	DC operation	mA	$\leq 1 \times (220 \text{ V}/U_s)$
Operating times at $0.8 \dots 1.1 \times U_s$²⁾ Total break time = Opening delay + Arcing time Values apply with coil in cold state and at operating temperature for operating range			
• AC operation			
- Closing	ON-delay NO OFF-delay NC	ms	5 ... 20 4 ... 12
- Opening	OFF-delay NO ON-delay NC	ms	3 ... 24 3 ... 20
• DC operation			
- Closing	ON-delay NO OFF-delay NC	ms	16 ... 140 13 ... 40
- Opening	OFF-delay NO ON-delay NC	ms	3 ... 6 4 ... 10
• Arcing time		ms	10
Operating times at $1.0 \times U_s$²⁾			
• AC operation			
- Closing	ON-delay NO OFF-delay NC	ms	6 ... 17 5 ... 12
- Opening	OFF-delay NO ON-delay NC	ms	3 ... 24 5 ... 20
• DC operation			
- Closing	ON-delay NO OFF-delay NC	ms	18 ... 42 15 ... 26
- Opening	OFF-delay NO ON-delay NC	ms	3 ... 5 4 ... 10
Main circuit			
AC capacity			
Utilization category AC-12 Rated operational current I_e (at 60 °C)	A	10	
Utilization category AC-15 and AC-14 Rated operational current I_e for rated operational voltage U_e			
	230/220 V	A	4
	400/380 V	A	3
	500 V	A	2
	690/660 V	A	1

¹⁾ Applies to 50/60 Hz coil
Operating range at 60 Hz: $0.85 \dots 1.1 \times U_s$;
at 50 Hz, $1.1 \times U_s$, side-by-side mounting and 100 % ON period the max. ambient temperature is +40 °C.

²⁾ The OFF-delay of the NO contact and the ON-delay of the NC contact are increased if the contactor coils are attenuated against voltage peaks (noise suppression diode 6 to 10 times; diode assemblies 2 to 6 times, varistor +2 to 5 ms).

3RH, 3TH Contactor Relays

3TH2 contactor relays, 4- and 8-pole

Contactor relays	Type	3TH2	
Main circuit			
<i>Load rating with DC</i>			
Utilization category DC-12 Rated operational current I_e for rated operational voltage U_e	A		10
• 1 conducting path ¹⁾	Up to 24 V A	4	
	60 V A	2	
	110 V A	1.1	
	240/220 V A	0.5	
• 2 conducting paths in series	Up to 24 V A	10	
	60 V A	10	
	110 V A	4	
	240/220 V A	2	
• 3 conducting paths in series	Up to 24 V A	10	
	60 V A	10	
	110 V A	6	
	240/220 V A	2.5	
Utilization category DC-13 Rated operational current I_e for rated operational voltage U_e			
• 1 conducting path	Up to 24 V A	2.1	
	60 V A	0.9	
	110 V A	0.52	
	240/220 V A	0.27	
• 2 conducting paths in series	Up to 24 V A	10	
	60 V A	3.5	
	110 V A	1.3	
	240/220 V A	0.9	
• 3 conducting paths in series	Up to 24 V A	10	
	60 V A	4.7	
	110 V A	3	
	240/220 V A	1.2	
<i>Induction motors</i>			
Rated power of induction motors			
Acc. to utilization category	110 V	kW	0.2
AC-2 and AC-3	230/220 V	kW	0.55
	400/380 V	kW	1.1
	500 V	kW	1.5
	690/660 V	kW	1.5
<i>Switching frequency</i>			
Switching frequency z in operating cycles/hour			
Rated operation for utilization category			
Dependence of the switching frequency z' on the operational current I' and operational voltage U': $z' = z \cdot (I_e/I') \cdot (400 V/U')^{1.5} \cdot 1/h$	AC-12/DC-12	h ⁻¹	1000
	AC-2	h ⁻¹	500
	AC-3	h ⁻¹	1000
	AC-15/AC-14	h ⁻¹	1200
	DC-13	h ⁻¹	1200
No-load switching frequency		h ⁻¹	10000
Conductor cross-sections			
Main and auxiliary conductors		 Screw terminals	
• Solid	mm ²	2 x (0.5 ... 2.5)	
• Finely stranded with end sleeve	mm ²	2 x (0.5 ... 1.5)	
• Terminal screw		M3	
		 Flat connectors	
• Finely stranded		0.5 ... 1	
When using a plug-in sleeve	- 6.3 ... 1 - 6.3 ... 2.5	mm ² mm ²	1 ... 2.5
		 Solder pin connections (only for printed circuit boards)	

¹⁾ Contact endurance 0.1×10^6 operating cycles.

3RH11 coupling relays for switching auxiliary circuits, 4-pole

Application

DC operation

IEC 60947 and EN 60947 (VDE 0660).

The 3RH11 coupling relays for switching auxiliary circuits are tailored to the special requirements of working with electronic controls.

The 3RH11 coupling relays cannot be extended with auxiliary switch blocks.







Function

No auxiliary switch blocks can be snapped onto 3RH11 coupling relays.

Coupling relays have a low power consumption, an extended magnetic coil operating range and an integrated surge suppressor for damping opening surges (exceptions: 3RH11 ...-HB40 and 3RH11 ...-MB40.-0KT0).

Technical specifications

All technical specifications not mentioned in the table below are identical to those of the 3RH11 contactor relays (see page 3/132).
The size S00 coupling relays (3RH11) cannot be extended with auxiliary switch blocks.

Contactor type Size	3RH11 ...-HB40 S00	3RH11 ...-JB40 S00	3RH11 ...-KB40 S00
Magnetic coil operating range	0.7 ... 1.25 x U_s		
Power consumption of the magnetic coil (for cold coil) Closing = Closed			
At $U_s = 17\text{ V}$	W	1.2	
At $U_s = 24\text{ V}$	W	2.3	
At $U_s = 30\text{ V}$	W	3.6	
Permissible residual current Of the electronics for 0 signal	< 10 mA x (24 V/ U_s)		
Overvoltage configuration of the magnetic coil	No overvoltage damping 	With diode 	With varistor 
Operating times			
• Closing at 17 V			
- ON-delay NO	ms	40 ... 120	
- OFF-delay NC	ms	30 ... 70	
• At 24 V			
- ON-delay NO	ms	30 ... 60	
- OFF-delay NC	ms	20 ... 40	
• At 30 V			
- ON-delay NO	ms	20 ... 50	
- OFF-delay NC	ms	15 ... 30	
• Closing at 17 ... 30 V			
- OFF-delay NO	ms	7 ... 17	7 ... 17
- ON-delay NC	ms	22 ... 30	60 ... 70
Upright mounting position	Request required		
Contactor type Size	3RH11 ...-MB40-0KT0 S00	3RH11 ...-VB40 S00	3RH11 ...-WB40 S00
Magnetic coil operating range	0.85 ... 1.85 x U_s		
Power consumption of the magnetic coil (for cold coil) Closing = Closed at $U_s = 24\text{ V}$	W	1.4	
Permissible residual current Of the electronics for 0 signal	< 8 mA x (24 V/ U_s)		
Overvoltage configuration of the magnetic coil	Diode, varistor or RC element, attachable 	Built-in diode 	Built-in varistor 
Operating times of the coupling relays			
• Closing at 20.5 V			
- OFF-delay	ms	110 ... 20	
- ON-delay	ms	120 ... 30	
• At 24 V			
- ON-delay NO	ms	25 ... 90	
- OFF-delay NC	ms	15 ... 80	
• At 44 V			
- OFF-delay	ms	50 ... 10	
- ON-delay	ms	60 ... 15	
• Closing at 17 ... 30 V			
- OFF-delay NO	ms	5 ... 20	5 ... 20
- ON-delay NC	ms	10 ... 30	30 ... 90
Upright mounting position	Request required		

3RT Coupling Relays

3RT10 coupling relays (interface), 3-pole, 3 ... 11 kW

Application

DC operation

IEC 60947, EN 60947 (VDE 0660).

The 3RT10 coupling relays for switching motors are tailored to the special requirements of working with electronic controls.

The 3RT10 1. coupling relays cannot be extended with auxiliary switch blocks.

Two single-pole auxiliary switch blocks can be fitted to the 3RT10 2. coupling relays.

Function





Coupling relays have a low power consumption, an extended operating range of the magnetic coil and an integrated surge suppressor for damping opening surges (exceptions: 3RT10 1.-1HB4. and 3RT10 1.-.MB4.-0KT0).

Technical specifications

All technical specifications not mentioned in the table below are identical to those of the 3RT10 contactors for switching motors (see page 3/20).

The 3RT10 1. coupling relays cannot be extended with auxiliary switch blocks.



Two single-pole auxiliary switch blocks can be fitted to the 3RT10 2. coupling relays (see "Accessories").

Contactor	Type Size		3RT10 1.-.HB4. S00	3RT10 1.-.JB4. S00	3RT10 1.-.KB4. S00	3RT10 2.-.KB4. S0
General data						
Mechanical endurance		Operating cycles	30 million			10 million
Protective separation between the coil and the main contacts acc. to EN 60947-1, Appendix N		V	400			
Control						
Magnetic coil operating range			0.7 ... 1.25 x U_s			
Power consumption of the magnetic coil (for cold coil) Closing = Closed		At U_s	17 V W	24 V W	30 V W	2.1 4.2 6.6
Permissible residual current Of the electronics (for 0 signal)			< 10 mA x (24 V/ U_s)			< 6 mA x (24 V/ U_s)
Overvoltage configuration of the magnetic coil			No overvoltage damping 	With diode 	With varistor 	With varistor 
Operating times of the coupling relays						
• Closing						
- At 17 V	ON-delay NO	ms	40 ... 120			93 ... 270
	OFF-delay NC	ms	30 ... 70			83 ... 250
- At 24 V	ON-delay NO	ms	30 ... 60			64 ... 87
	OFF-delay NC	ms	20 ... 40			55 ... 78
- At 30 V	ON-delay NO	ms	20 ... 50			53 ... 64
	OFF-delay NC	ms	15 ... 30			45 ... 56
• Opening at 17... 30 V	OFF-delay NO	ms	7 ... 17	40 ... 60	7 ... 17	18 ... 19
	ON-delay NC	ms	22 ... 30	60 ... 70	22 ... 30	24 ... 25

3RT Coupling Relays

3RT10 coupling relays (interface),
3-pole, 3 ... 11 kW

All technical specifications not mentioned in the table below are identical to those of the 3RT10 contactors for switching motors (see page 3/20).
The 3RT10 1. coupling relays cannot be extended with auxiliary switch blocks.
Power consumption of the coils 1.4 W at 24 V.

Contactors	Type Size		3RT10 1.-1MB4.-0KT0 S00	3RT10 1.-1VB4. S00	3RT10 1.-1WB4. S00
General data					
Mechanical endurance		Oper- ating cycles	30 million		
Protective separation between the coil and the main contacts acc. to EN 60947-1, Appendix N		V	400		
Control					
Power consumption of the magnetic coil (for cold coil) Closing = Closed		At U_s 24 V W	1.4		
Permissible residual current, upright mounting position			On request		
Overvoltage configuration of the magnetic coil			No overvoltage damping 	With diode 	With varistor 
Operating times of the coupling relays					
• Closing					
- At 20.5 V	ON-delay NO	ms	40 ... 130		
	OFF-delay NC	ms	40 ... 125		
- At 24 V	ON-delay NO	ms	40 ... 100		
	OFF-delay NC	ms	30 ... 90		
- At 44 V	ON-delay NO	ms	20 ... 30		
	OFF-delay NC	ms	15 ... 25		
• Opening					
	OFF-delay NO	ms	9 ... 12	45 ... 65	10 ... 15
	ON-delay NC	ms	12 ... 16	52 ... 72	15 ... 20

3TX7, 3RS18 Coupling Relays

3TX7 Coupling Relays, Narrow Design

Relay couplers

Design

Installation instructions

Snap-on mounting is possible on horizontal and vertical standard mounting rails. In the case of vertical standard mounting rails and closely mounted units, the maximum permissible ambient temperature $T_U = 40\text{ °C}$. Any service position is possible.

If the coupling elements are operated continuously 24 hours per day (100 % ON period) at the maximum permissible rated control supply voltage and the maximum permissible ambient temperature, it is recommended that no similar equipment or other units that generate heat are placed directly adjoining the coupling elements because this can reduce the endurance of the couplers.

A distance > 10 mm to the right and left of the coupling link reduces the risk of a premature failure under these operating conditions.

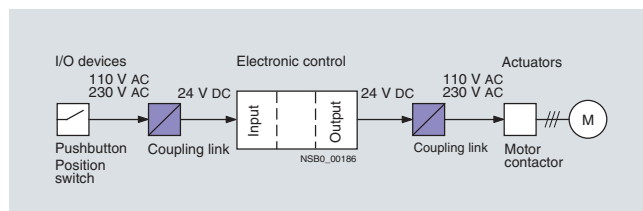

Function

Surge suppression

The coupling links have been tested with 1×10^5 operating cycles at AC-15 operation with the values specified in the Technical specifications.

If inductive loads are connected in parallel, the endurance of the relay couplers can be increased.

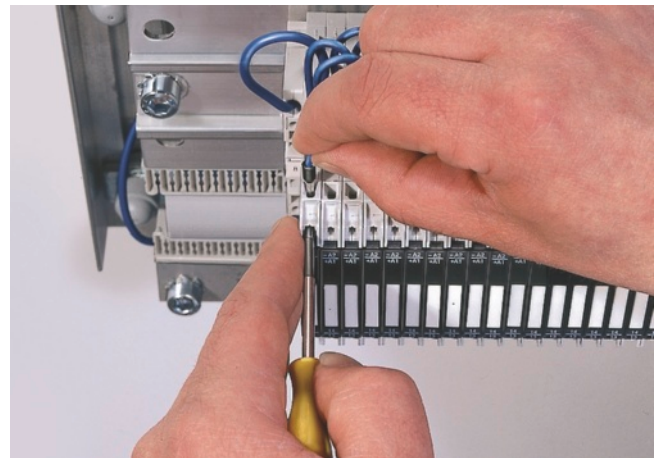

Note:

If capacitive loads without series resistors are switched, which limit temporary peak currents, microscopic welding of the relay contacts may result.



Connecting a cable to the spring-type terminals

Technical specifications

Type	3TX7 002/3TX7 003	
General data		
Rated insulation voltage U_i (degree of pollution 3)	V	300
Protective separation for relay couplers ¹⁾ Between the coil and the contacts acc. to EN 60947-1, Appendix N	V	Up to 300 AC
Degree of protection	<ul style="list-style-type: none"> • Connections for relay couplers • Enclosure 	IP20 IP30
Short-circuit protection acc. to IEC 60947-5-1 (weld-free protection at $I_k \geq 1\text{ kA}$) Fuse links, gL/gG operational class	A	4
Permissible ambient temperature	<ul style="list-style-type: none"> • During operation • During storage 	°C -25 ... +60 °C -40 ... +80
Conductor cross-sections		
<ul style="list-style-type: none"> • Solid • Finely stranded with or without end sleeve • Terminal screw Corresponding opening tool For 3TX7 003:	mm ² mm ²	 Screw terminals 1 x (0.25 ... 4) 1 x (0.5 ... 2.5) M3 Screwdriver, 3.5 mm x 0.5 mm (8WA2 804)
<ul style="list-style-type: none"> • Solid or finely stranded • Finely stranded with end sleeve Corresponding opening tool	mm ² mm ²	 Spring-type terminals 1 x (0.08 ... 2.5) 1 x (0.25 ... 1.5) Screwdriver, 3.5 mm x 0.5 mm (8WA2 803)

¹⁾ For 3TX7 00.-1FB02, no protective separation according to EN 61140.

3TX7, 3RS18 Coupling Relays

3TX7 Coupling Relays, Narrow Design

Relay couplers

Type	3TX7 002-/3TX7 003-	1AB02	1AB00	1BB00	1FB02	1CB00	2AB00	2AE00	1BF00 2BF02	2AF00	2AF05
Control side											
Operating range		0.8 ... 1.25 x U_s						0.8 ... 1.1 x U_s			
Power consumption at U_s	W	0.75	0.75	0.75	1.2	1.2	0.75	0.75	1.2	1.2	1.2
Release voltage	%	≥ 10									
Max. permissible cable length (min. cross-section: 0.75 mm ²)	AC DC	m m	300 2000	300	300	300	300	300	15	7	7 350
Permissible residual current of the electronics (with 0 signal)		mA	2	2	2	2	4	2	0.4	0.35	0.35 4
Operating times at U_s	• ON-delay • OFF-delay	ms ms	< 8 < 10								
Function display			LED yellow								

Type	3TX7 002/3TX7 003										
Load side											
Rated currents¹⁾											
Continuous thermal current I_{th}		A	6								
Rated operational currents I_e											
Acc. to utilization categories (EN 60947) (3TX7 002-1CB00: AC-15, $I_e = 2$ A)											
• AC-15	- At 24 V - At 110 V - At 230 V	A A A	3 3 3								
• DC-13	- At 24 V - At 110 V - At 230 V	A A A	1 0.2 0.1								
Switching current With resistive load to VDE 0435 (relay standard) and EN 60947											
• AC-12	- At 24 V - At 110 V - At 230 V	A A A	6 6 6								
• DC-12	- At 24 V - At 110 V - At 230 V	A A A	6 0.2 0.2								
Switching voltage	AC/DC	V	24 ... 250								
• Min. contact load for 3TX7 00...02		mA	1 V, 0.1 AC/DC								
Mechanical endurance		Operating cycles	20 x 10 ⁶								
Electrical endurance at I_e		Operating cycles	1x10 ⁵								
Switching frequency		Operating cycles 1/h	5000								
Contact material for 3TX7 00...02			Ag/Ni 0.15 hard gold-plated								
Power limit hard gold-plating for 3TX7 00...02											
• Voltage		V	30								
• Current		mA	20								

¹⁾ Capacitive loads can result in micro-weldings on the contacts.



Note:

If inductive loads are connected in parallel, the endurance of the relay couplers can be increased.

3TX7, 3RS18 Coupling Relays

3TX7 Coupling Relays, Narrow Design

Relay couplers

Type	3TX7 004/3TX7 005				
General data					
Rated insulation voltage U_i (degree of pollution 3)	V	300			
Protective separation for relay couplers Between the coil and the contacts acc. to EN 60947-1, Appendix N	V	Up to 300 AC			
Degree of protection	<ul style="list-style-type: none"> • Terminals • Enclosure 	IP20 IP30			
Short-circuit protection acc. to IEC 60947-5-1 (weld-free protection at $I_k \geq 1$ kA) Fuse links, gL/gG operational class	A	4			
Permissible ambient temperature	<ul style="list-style-type: none"> • During operation • During storage 	°C	-25 ... +60 -40 ... +80		
Conductor cross-sections					
For 3TX7 004:			 Screw terminals		
<ul style="list-style-type: none"> • Solid • Finely stranded without end sleeve • Finely stranded with end sleeve • Terminal screws 	mm ² mm ² mm ²		1 x (0.25 ... 4) 1 x (0.5 ... 2.5) 1 x (0.5 ... 2.5) M3		
For 3TX7 005:			 Spring-type terminals		
<ul style="list-style-type: none"> • Solid or finely stranded • Finely stranded with end sleeve 	mm ² mm ²		1 x (0.08 ... 2.5) 1 x (0.25 ... 1.5)		
Control side					
Operating range	<ul style="list-style-type: none"> • At $U_s = 24$ V AC/DC • At $U_s = 110$ V and 230 V AC/DC 		0.7 ... 1.25 x U_s 0.8 ... 1.1 x U_s		
Power consumption at U_s			0.5 W; 3TX7 00...05: 1 W at 230 V DC/6 VA at 230 V AC		
Permissible residual current of the electronics (for 0 signal)	<ul style="list-style-type: none"> • Width 6.2 mm • $U_s = 24$ V • $U_s > 24$ V • From 12.5 mm width 	mA mA mA	2 0.5 2.5		
	Exceptions: 3TX7 00...1BF05	mA mA	5 ($U_s = 230$ V AC) 0.5 ($U_s = 230$ V DC)		
Operating times at U_s	<ul style="list-style-type: none"> • ON-delay • OFF-delay 	ms ms	< 8 < 15		
Function display			LED yellow		
Type					
	3TX7 004/3TX7 005	-1.F00 -2ME02 -2MF02	-1.B... -2MB02	-1BF05	
Max. permissible cable length (min. conductor cross-section: 0.75 mm ²)					
	AC	m	40	400	350
	DC	m	2000	2000	2000

3TX7, 3RS18 Coupling Relays

3TX7 Coupling Relays, Narrow Design

Relay couplers

Type	3TX7 00.-1A/-1B/-1C/-1G/-1H/-1L		3TX7 00.-.M	
Load side				
Rated operational currents I_e ¹⁾				
• Continuous thermal current I_{th}		A	6	
• Rated operational current I_e acc. to utilization categories (EN 60947)				
- AC-15	At 24 V	A	3	2
	At 110 V	A	3	2
	At 230 V	A	3	2
- DC-13	At 24 V	A	1	
	At 110 V	A	0.2	
	At 230 V	A	0.1	
Switching current with resistive load to VDE 0435 (relay standard) and VDE 0660				
- AC-12	At 24 V	A	6	
	At 110 V	A	6	
	At 230 V	A	6	
- DC-12	At 24 V	A	6	
	At 110 V	A	0.3	
	At 230 V	A	0.2	
Power limit for hard gold-plating				
• Voltage		V	30	
• Current		mA	20	
Switching voltage AC/DC V 17 ... 250				
Min. switching voltage (reliability 1 ppm) ²⁾				
• Standard contact			17 V DC/5 mA	
• Hard gold-plated contacts			5 V DC/1 mA	
Endurance				
• Mechanical		Operating cycles	20 x 10 ⁶	
• Electrical (at I_e)		Operating cycles	1 x 10 ⁶	0.5 x 10 ⁶
Switching frequency Operating cycles 1/h 5000				

¹⁾ Capacitive loads can result in micro-weldings on the contacts.

²⁾ 1 ppm = 1st fault in one million operating cycles.

Note:

If inductive loads are connected in parallel, the endurance of the relay couplers can be increased.

3TX7, 3RS18 Coupling Relays

3TX7 Coupling Relays, Narrow Design

Relay couplers with plug-in design

Design

Coupling links are used to connect signals to and from a PLC. The plug-in relays enable the relay to be replaced at the end of its service life without detaching the wiring.

For easy linking of the signals, each terminal can be jumpered using an external connecting comb.

Technical specifications

Type	3TX7 01.-1	
General data		
Rated insulation voltage U_i (degree of pollution 2)	V	300
Protective separation Between the coil and the contacts acc. to EN 60947-1, Appendix N	V	Up to 300 AC
Degree of protection	<ul style="list-style-type: none"> Enclosure Relays 	IP20 IP40
Short-circuit protection acc. to IEC 60947-5-1 (weld-free protection at $I_k \geq 1$ kA) Fuse links, gL/gG operational class	A	4
Permissible ambient temperature	<ul style="list-style-type: none"> During operation During storage 	<ul style="list-style-type: none"> °C °C -25 ... +55 -40 ... +80
Conductor cross-sections		
<ul style="list-style-type: none"> Solid Finely stranded with or without end sleeve Terminal screw Permissible opening tool	mm ² mm ²	 Screw terminals 1 x (0.5 ... 2.5) 1 x (0.5 ... 1.5) M2.5 Screwdriver with blade width 3.0 mm x 0.5 mm

Type	3TX7 01.-1.H	3TX7 01.-1.B	3TX7 01.-1.E	3TX7 01.-1.F
Control side				
Operating range	0.9 ... 1.1 U_s	0.7 ... 1.25 U_s	0.8 ... 1.1 U_s	0.8 ... 1.1 U_s
Power consumption at U_s (24 V/115 V/230 V)	< 0.5/0.5/1			
Release voltage	10 of U_s			
Max. permissible cable length (min. conductor cross-section: 0.75 mm ²)				
<ul style="list-style-type: none"> AC DC 	m m	100 2000	70 800	40 800
Permissible residual current of the electronics (for 0 signal)	mA	1	2	0.3
Operating times at U_s				
<ul style="list-style-type: none"> ON-delay OFF-delay 	ms ms	< 6 < 6	< 7 < 7	< 8 < 20
Function display	LED yellow			
Protection circuit	<ul style="list-style-type: none"> DC AC 	Freewheel diode + Reverse polarity protection Rectifier bridge		

Type	3TX7 01.-1		
Load side			
Rated currents¹⁾			
<ul style="list-style-type: none"> Continuous thermal current I_{th} Rated operational currents I_e <ul style="list-style-type: none"> AC-15 <ul style="list-style-type: none"> At 24 V At 110 V At 230 V DC-13 <ul style="list-style-type: none"> At 24 V At 110 V At 230 V 	A A A A A A A	5 3 3 3 1 0.2 0.1	
Switching voltage	AC/DC	V	24 ... 250
Min. contact load (reliability 1 ppm ²⁾			
<ul style="list-style-type: none"> Standard contact Hard gold-plated contacts 			17 V DC/5 mA 5 V DC/1 mA
Mechanical endurance	Operating cycles		20×10^6
Electrical endurance at I_e acc. to AC-15	Operating cycles		100000
Switching frequency	Operating cycles	1/h	5000

Note: If inductive loads are connected in parallel, the endurance of the relay couplers can be increased.

¹⁾ Capacitive loads can result in micro-weldings on the contacts.

²⁾ 1 ppm = 1st fault in one million operating cycles.

3TX7, 3RS18 Coupling Relays

3TX7 Coupling Relays, Narrow Design

Semiconductor couplers

Overview

AC and DC operation

EN 60664-1, EN 60947 and EN 50005; optocouplers:
EN 60747-5, IEC 61131-2 (programmable controllers).

In the coupling links in double-decker design, the connections are arranged on two levels; the units are extremely compact. Connection method: screw or spring-type terminals. For test purposes, versions are available with manual 0 automatic switches.

The input and output coupling links differ with regard to the positioning of the terminals and the LEDs. For equipment identification purposes, each coupling link has a blank labeling plate.

In accordance with the technical specifications of electronic systems, the coupling links have a lower power consumption.

Design

Installation instructions

Snap-on mounting is possible on horizontal and vertical standard mounting rails. In the case of vertical standard mounting rails and closely mounted units, the maximum permissible ambient temperature $T_U = 40\text{ °C}$. Any service position is possible.

If the coupling elements are operated continuously 24 hours per day (100 % ON period) at the maximum permissible rated control supply voltage and the maximum permissible ambient temperature, it is recommended that no similar equipment or other units that generate heat are placed directly adjoining the coupling elements because this can reduce the endurance of the couplers.

A distance $> 10\text{ mm}$ to the right and left of the coupling link reduces the risk of a premature failure under these operating conditions.

Optocouplers switch using semiconductors. These are not subject to wear; welding is not possible.

The 6.2 mm wide optocouplers have an opening in the right-hand side of the casing. They can, like relay couplers, be mounted side-by-side without gaps.

Function

Surge suppression

In the case of optocouplers, the contact element is a semiconductor. These are not subject to wear; so welding is not possible.

Note:

With semiconductors, the switching current is not dependent on the inductance of the load, i. e. the switching current for a DC-13 load is the same as that for an inductive DC-12 load. This means that coupling links with a semiconductor output are particularly suitable for inductive loads such as solenoid valves. It is not relevant to specify the number of operating cycles because this does not affect the endurance of the semiconductor provided it is not overheated.

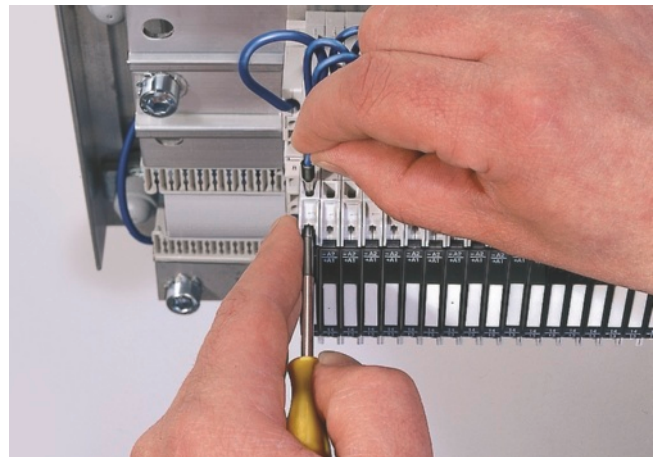

Connecting a cable to the spring-type terminals

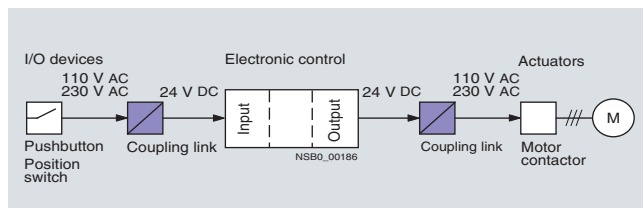

3TX7, 3RS18 Coupling Relays

3TX7 Coupling Relays, Narrow Design

Semiconductor couplers

Technical specifications

Type	3TX7 004-1.F.5	
General data		
<i>Derating diagram for 3TX7 002-3AB01 load current depending on the ambient temperature T_U</i>		
	Rated insulation voltage U_i (degree of pollution 3)	V 300
	Optoelectronic coupling element for protective separation Acc. to EN 60947-1, Appendix N	V
Permissible ambient temperature	°C	-25 ... +60
• During operation	°C	-40 ... +80
• During storage		
Conductor cross-sections		
• Solid	mm ²	1 x (0.25 ... 4)
• Finely stranded with or without end sleeve	mm ²	1 x (0.5 ... 2.5)
• Terminal screws		M3
		Screw terminals



Type	3TX7002-	3AB00	3AB01	4AB00	4AG00
Control side					
Operating range	V	17 ... 30 DC	11 ... 30 DC	17 ... 30 AC/DC	88 ... 264 AC
Control side power consumption					
	At 17 V DC	mA < 18	< 5	--	--
	At 24 V DC	mA < 20	< 7	--	--
	At 30 V DC	mA < 22	< 8.5	--	--
	At 17 V AC/DC	mA --	--	< 10	--
	At 24 V AC/DC	mA --	--	< 14	--
	At 30 V AC/DC	mA --	--	< 18	--
	At 88 V AC	mA --	--	--	< 9
	At 230 V AC	mA --	--	--	< 24
	At 264 V AC	mA --	--	--	< 28
Release voltage	V	> 5	> 8	> 5	> 40
Operating times					
• ON-delay	At 17 V DC	ms < 10	< 0.1	1	--
	At 24 V DC	ms < 10	< 0.1	1	--
	At 30 V DC	ms < 10	< 0.1	1	--
	At 17 V AC/DC	ms --	--	< 1	--
	At 24 V AC/DC	ms --	--	< 1	--
	At 30 V AC/DC	ms --	--	< 1	--
	At 88 V AC	ms --	--	--	< 18
	At 230 V AC	ms --	--	--	< 20
	At 264 V AC	ms --	--	--	< 22
• OFF-delay	At 17 V DC	ms < 10	< 0.1	< 18	--
	At 24 V DC	ms < 10	< 0.1	< 25	--
	At 30 V DC	ms < 10	< 0.1	< 30	--
	At 17 V AC/DC	ms --	--	< 18	--
	At 24 V AC/DC	ms --	--	< 25	--
	At 30 V AC/DC	ms --	--	< 30	--
	At 88 V AC	ms --	--	--	< 10
	At 230 V AC	ms --	--	--	< 20
	At 264 V AC	ms --	--	--	< 25
Function display		LED yellow	LED yellow	LED yellow	LED yellow
Max. permissible cable length (min. cond. cross-section: 0.75 mm ²)	AC	m --	--	1000	140
	DC	m 2000	2000	2000	--
Load side					
Switching current	A	1.8	1.5 (see derating diagram)	0.1	0.1
Short-time loading capacity					
	A	20	4	1	1
	ms	20	200	20	20
Contacts					
		1 NO, Triac	1 NO, transistor	1 NO, transistor	1 NO, transistor
Switching voltage¹⁾ (operating range)	V	48 ... 264	--	--	--
		• Effective AC 50/60 Hz	≤ 60	≤ 30	≤ 30
		• DC	--	--	--
Minimum load current	mA	60	--	--	--
Voltage drop conducting	V	≤ 1.5	≤ 1.1	≤ 1.7	≤ 0.3
Permissible residual current of the electronics (with 0 signal)	mA	< 5	< 0.1	< 0.1	< 0.001
Switching frequency at I_e	Hz	1	1	5	5

¹⁾ Observe minimum switching voltage for 3TX7 002-3AB00.

3TX7, 3RS18 Coupling Relays

3TX7 Coupling Relays, Narrow Design

Semiconductor couplers

Type	3TX7 004/3TX7 005	
General data		
Rated insulation voltage U_i (degree of pollution 3)	V	300
Protective separation acc. to EN 60947-1, Appendix N for optocouplers	V	Up to 300
Permissible ambient temperature		
• During operation	°C	-25 ... +60
• During storage	°C	-40 ... +80
Conductor cross-sections		
For 3TX7 004		 Screw terminals
• Solid	mm ²	1 x (0.25 ... 4)
• Finely stranded without end sleeve	mm ²	1 x (0.5 ... 2.5)
• Finely stranded with end sleeve	mm ²	1 x (0.5 ... 2.5)
• Terminal screws		M3
Permissible opening tool		Screwdriver, 3.5 mm x 0.5 mm (8WA2 804)
For 3TX7 005		 Spring-type terminals
• Solid or finely stranded	mm ²	1 x (0.08 ... 2.5)
• Finely stranded with end sleeve	mm ²	1 x (0.25 ... 1.5)
Permissible opening tool		Screwdriver, 3.5 mm x 0.5 mm (8WA2 803)

Type	3TX7 004-/3TX7 005-	3AB04	3AC.4	3AC03	3PB54	4PG24
Control side						
Operating range	V	11 ... 30 DC				110 ... 230 AC/DC
Power consumption	• At 24 V DC • At 230 V AC	W W	≤ 0.5 --	≤ 0.5 --	≤ 0.25 --	≤ 0.2 -- ≤ 1.5
Release voltage	V	6	5	6	9	20
Permissible residual current of the electronics (for 0 signal)	mA	2.3	2.6	1.5	1.5	0.4
Operating times	• ON-delay • OFF-delay	ms ms	2.5 8	0.3 4	10 10	0.3 0.3 10 12
Function display		LED yellow				
Max. permissible cable length (min. conductor cross-section: 0.75 mm ²)	m	1700	2000	2000	2000	40
Load side						
Switching voltage	V	10 ... 48 DC	10 ... 30 DC	24 ... 250 AC	10 ... 30 DC	10 ... 30 DC
Switching current	A	0.5	5	2	1.5	0.1
Short-time loading capacity	A	1.5	Short-circuit resistant ¹⁾	100	Short-circuit resistant ²⁾	0.2
	ms	20	--	20	--	3
Contacts		1 NO, transistor		1 NO, Triac	1 NO, transistor	
Minimum load current	mA	--	500 ³⁾	50	--	--
Voltage drop conducting	V	≤ 1	≤ 0.5	≤ 1.6	≤ 0.5	≤ 1.5
Leakage current of the electronics for 0 signal	mA	< 0.1	< 0.1	< 6	< 0.1	< 0.1
Switching frequency for resistive load	Hz	50	50	1	500	25

¹⁾ In the event of a short-circuit or overload, the semiconductor output switches off. In order to operate the device again, it must be temporarily disconnected from the power supply.

²⁾ In the event of a short-circuit or overload, the current is limited by the semiconductor output.

³⁾ If the current falls below the minimum load current, the built-in semiconductor detects an open circuit in the load circuit. The control must be temporarily switched off for resetting.

3TX7, 3RS18 Coupling Relays

3TX7 Coupling Relays, Narrow Design

Semiconductor couplers

Type	3TX7 004-/3TX7 005-		3PB74	3PG74
Control side				
Operating range		V	11 ... 30 DC	88 ... 253 AC/DC
Power consumption	<ul style="list-style-type: none"> • At 24 V DC • At 110 V DC • At 230 V AC 	W	0.2	--
		W	--	0.2
		W	--	≤ 1.5
Release voltage		V	6	25
Permissible residual current of the electronics (for 0 signal)		mA	1.2	1
Operating times	<ul style="list-style-type: none"> • ON-delay • OFF-delay 	ms	0.2	1.5
		ms	1.0	75
Function display			LED yellow	
Max. permissible cable length (min. conductor cross-section: 0.75 mm ²)		m	2000	40
Load side				
Switching voltage max.	<ul style="list-style-type: none"> • Min. • Max. 	V	11 DC	
		V	30 DC	
Switching current		A	3	
Short-time loading capacity		A	Short-circuit resistant ¹⁾	
		ms	--	
Contacts			1 NO, transistor	
Minimum load current		mA	--	
Voltage drop conducting		V	≤ 0.5	
Leakage current of the electronics for 0 signal		mA	0.1	
Switching frequency for resistive load		1/s	10	

¹⁾ In the event of a short-circuit or overload, the current is limited by the semiconductor output.

3TX7, 3RS18 Coupling Relays

3RS18 Coupling Relays with Industrial Housing

Relay couplers



Overview

The new 3RS18 coupling relays are couplers in the well-proven standard 22.5 mm timing relay enclosure. The series comprises relays with 1, 2 and 3 changeover contacts with screw and spring-type connections for combined voltages and wide voltage ranges.

Application

Typical applications are found wherever solid-state compatible contacts are required and equipment with a wide voltage range is implemented.

Technical specifications

Type	3RS1800	
General data		
Rated insulation voltage U_i degree of pollution 3	V	500
Protective separation acc. to EN 60947-1, Appendix N between the coil and the contacts and between the individual contacts.	V	300
Degree of protection acc. to EN 60529		
<ul style="list-style-type: none"> Enclosure Cover 		IP20 IP40
Permissible ambient temperature		
<ul style="list-style-type: none"> During operation During storage 	°C °C	-25 ... +60 -40 ... +80
Permissible		Any
Shock resistance Half-sine acc. to IEC 60028-2-27	g/ms	15/11
Vibration resistance Acc. to IEC 60068-2-6	g/ms	10 ... 55/0.35
Electromagnetic compatibility (EMC) Tests acc. to basic specification		IEC 61000-6-2/IEC 61000-6-4
Conductor cross-sections		
		 Screw terminals
<ul style="list-style-type: none"> Solid Finely stranded with end sleeve AWG cables, solid or stranded 	mm ² mm ² mm ²	1 x (0.5 ... 4); 2 x (0.5 ... 2.5) 2 x (0.5 ... 2.5) 2 x (20 ... 14)
<ul style="list-style-type: none"> Terminal screw Tightening torque 	M Nm	M3.5 0.8 ... 1.2
Corresponding opening tool		Standard screwdriver, size 2 or Pozidriv 2
		 Spring-type terminals
<ul style="list-style-type: none"> Solid Finely stranded without end sleeve Finely stranded with end sleeve AWG cables, solid or stranded 	mm ² mm ² mm ² AWG	2 x (0.25 ... 1.5) 2 x (0.25 ... 1.5) 2 x (0.25 ... 1) 2 x (24 ... 16)
Corresponding opening tool		Screwdriver with 3 mm blade or 8WA2 807 opening tool
Control side		
Operating range		0.85 ... 1.1 x U_s
Rated power		
<ul style="list-style-type: none"> Max. DC Max. AC 	W VA	1 8
Mains buffering		
<ul style="list-style-type: none"> Depends on version 	ms	5 ... 100
Max. permissible cable length		
330 pF/m AC Min. cross-section: 0.75 mm ² DC		
<ul style="list-style-type: none"> 1 CO - AC - DC 2 CO - AC - DC 3 CO - AC - DC 	m m m m m m	100 2000 200 1500 200 1500
Permissible residual current Of the electronics (for 0 signal)	mA	2
Temporarily flowing capacitor charging currents On energizing supply voltage	mA	450 for $\leq 500 \mu\text{s}^1$
Function display		LED yellow

¹⁾ Note the short-circuit limitation for control with the semiconductor version!

3TX7, 3RS18 Coupling Relays

3RS18 Coupling Relays with Industrial Housing

Relay couplers

Type		3RS18 ..-....0	3RS18 ..-....1
Load side			
Continuous thermal current I_{th}	A	6	
Rated operational currents I_e			
• AC-15	- At 24 V A - At 110 V A - At 230 V A - At 400 V A	3 3 3 3	
• DC-13	- At 24 V A - At 110 V A - At 230 V A	1 0.2 0.1	
Switching current for resistive load			
• AC-12	- At 24 V A - At 115 V A - At 230 V A - At 400 V A	5 5 5 5	
• DC-12	- At 24 V A - At 115 V A - At 230 V A	5 0.2 0.2	
Switching voltage	• Max. AC V • Max. DC V	400 250	
Contact material		AgSnO ₂	AgNi 0.15 hard gold-plated
Min. contact load			
• Standard contact		17 V DC/5 mA at 1 ppm fault	--
• Hard gold-plated contacts		--	5 V DC/1 mA at 1 ppm fault
Endurance			
• Mechanical	Operating cycles	20 x 10 ⁶	
• Electrical (at I_e)	Operating cycles	1 x 10 ⁶	
Operating times			
• Max. ON-delay at U_s	ms	8 (for 3RS18 00-. .W0. < 30)	
• Max. OFF-delay at U_s	ms	30 (for 3RS18 00-. .W0. < 150)	
Switching frequency	Operating cycles 1/h	5000	
Short-circuit protection	A	4	
Weld-free protection with gL/gG operational class at $I_k \geq 1$ kA			

Overview

The LZX complete units and accessory parts previously available are no longer listed in this catalog. They can still be supplied however in limited quantities. In their place you will now find the new LZS types. LZS complete units are fully compatible with their predecessors, the LZX complete units. The LZX plug-in relays have not been changed and are used accordingly in both the LZS and the LZX series.

Due to differences in geometry the LED modules, plug-in bases, retaining brackets and labels can be combined and/or used in only the respective series, LZS or LZX.

List for converting from LZX to LZS plug-in relay couplers:

Complete units	
Previous Order No.	New Order No.
LZX:PT3A5L24	LZS:PT3A5L24
LZX:PT3A5R24	LZS:PT3A5R24
LZX:PT3A5S15	LZS:PT3A5S15
LZX:PT3A5T30	LZS:PT3A5T30
LZX:PT5A5L24	LZS:PT5A5L24
LZX:PT5A5R24	LZS:PT5A5R24
LZX:PT5A5S15	LZS:PT5A5S15
LZX:PT5A5T30	LZS:PT5A5T30
LZX:PT5B5L24	LZS:PT5B5L24
LZX:PT5B5R24	LZS:PT5B5R24
LZX:PT5B5S15	LZS:PT5B5S15
LZX:PT5B5T30	LZS:PT5B5T30
LZX:RT3A4L24	LZS:RT3A4L24
LZX:RT3A4R24	LZS:RT3A4R24
LZX:RT3A4S15	LZS:RT3A4S15
LZX:RT3A4T30	LZS:RT3A4T30
LZX:RT3B4L24	LZS:RT3B4L24
LZX:RT3B4R24	LZS:RT3B4R24
LZX:RT3B4S15	LZS:RT3B4S15
LZX:RT3B4T30	LZS:RT3B4T30
LZX:RT4A4L24	LZS:RT4A4L24
LZX:RT4A4R24	LZS:RT4A4R24
LZX:RT4A4S15	LZS:RT4A4S15
LZX:RT4A4T30	LZS:RT4A4T30
LZX:RT4B4L24	LZS:RT4B4L24
LZX:RT4B4R24	LZS:RT4B4R24
LZX:RT4B4S15	LZS:RT4B4S15
LZX:RT4B4T30	LZS:RT4B4T30

Prices for the new LZS series are lower than for the previous LZX series.

Note:

In addition the LZS series offers not only service-proven screw connections but also versions with plug-in terminals.

The following conversion list will help you to change over from the LZX types previously sold to the new LZS types. Please contact your regional adviser if you have any questions.

List for converting from LZX to LZS accessories for individual modules:

Accessories for individual modules	
Previous Order No.	New Order No.
LZX:MT28800	LZS:MT28800
LZX:MT78750	LZS:MT78750
LZX:PT16016	LZS:PT17024 ¹⁾ LZS:PT17021 ²⁾
LZX:PT16040	LZS:PT17040
LZX:PT78702	LZS:PT78720
LZX:PT78703	LZS:PT78730
LZX:PT78704	LZS:PT78740
LZX:PT78802	LZS:PT78722
LZX:PT78804	LZS:PT78742
LZX:RPMG0024	LZS:PTMG0024
LZX:RPMG0524	LZS:PTMG0524
LZX:RPMG0730	LZS:PTMG0730
LZX:RPML0024	LZS:PTML0024
LZX:RPML0524	LZS:PTML0524
LZX:RPML0730	LZS:PTML0730
LZX:RPMT00A0	LZS:PTMT00A0
LZX:RPMU0548	LZS:PTMU0524
LZX:RPMU0730	LZS:PTMU0730
LZX:RT16016	LZS:RT17016
LZX:RT78625	LZS:RT78725
LZX:RT78626	LZS:RT78726
LZX:RY16040	LZS:RT17040

¹⁾ LZS:PT17024 for PT standard base: Without logical isolation, screw terminals.

²⁾ LZS:PT1721 for PT base with logical isolation, screw terminals and plug-in terminals.

Coupling Relays with LZS, LZX Plug-in Relays

Plug-in relay couplers

Design

Plug-in relay coupling links can be ordered complete or as single modules.

Mounting

The relays are plugged into the base and this is snapped onto a TH 35 standard mounting rail according to EN 60715.

A retaining bracket can be ordered for the MT series that additionally fixes the relay into a plug-in base (under conditions of increased mechanical stress). For the RT and PT series, a combined fixing and ejection bracket is available which can be used to remove the relay where access is difficult, for example, when relays are mounted side-by-side.

They can be mounted as required.

Function

In accordance with the technical specifications of electronic systems, the coupling links have a lower power consumption. In the versions equipped with LEDs, these indicate the switching state. The LZS:PT/MT plug-in relay couplers have a test button. This can be used to force the plug-in relay coupler into the tripped state and to lock it. This is indicated by a raised petrol-colored lever.

Surge suppression

The 24 V DC relays LZX:RT and LZX: PT with LEDs can be supplied with, all others without integral surge suppression (free-wheel diode connected in parallel with A1/A2). The positive supply voltage must be connected to coil terminal A1.

Logical disconnection

The terminals for the contacts and the terminals for the coil are arranged on separate levels, e. g. above for contacts and below for coil. Logical isolation is not necessarily protective separation.

Protective separation

For protective separation, transfer of the voltage of one circuit to another circuit is prevented to a suitable degree of safety (requirements and tests are described in EN 60947-1 in Appendix N).

Control with solid-state output

In the case of solid-state outputs (e. g. BERO) with overload and short-circuit protection, you must make allowance during configuration for the temporarily flowing capacitor charging currents!

This is possible, for example, by using a suitable LZS plug-in relay coupler.

Technical specifications

Relay type		LZX:RT print relay, 8-pole, (12.7 mm) 1 CO/2 CO				LZX:PT industrial relay, 8-, 11- and 14-pole, (22.5 mm) 2 CO/3 CO/4 CO			
General data									
Rated control supply voltage U_s ¹⁾	V	24 DC	24 AC	115 AC	230 AC	24 DC	24 AC	115 AC	230 AC
Rated insulation voltage U_i Degree of pollution	V	250	3			250	3		
Overvoltage category Acc. to EN 60947-1, Appendix N		III				III			
Protective separation Between the coil and the contacts Acc. to EN 60947-1, Appendix N		Up to 250 V (with plug-in base LZS:RT78726) No (for complete units with standard socket)				No			
Degree of protection of relay/base		IP67/IP20				IP50/IP20			
Permissible ambient temperature									
• During operation	°C	-40 ... +70				-40 ... +70			
• During storage	°C	-40 ... +80				-40 ... +80			
Conductor cross-sections									
• Solid									
- LZS:RT.A.../LZS:RT.B....	mm ²	2 x 2.5				2 x 2.5			
- LZS:RT.D....	mm ²	2 x 0.75 ... 1.5				2 x 0.75 ... 1.5			
• Finely stranded with or without end sleeve									
- LZS:PT.A.../LZS:PT.B....	mm ²	2 x 1.5				2 x 1.5			
- LZS:PT.D....	mm ²	2 x 0.75 ... 1.5/1.0				2 x 0.75 ... 1.5/1.0			
• Permissible opening tool		Screwdriver for slotted screws, 3.0 ... 3.5 mm x 0.5 mm							
Control side									
Operating range									
At 20 °C	V	16.8 ... 52	18 ... 52	86.3 ... 127	172 ... 264	18 ... 40.8	19.2 ... 39.6	92 ... 190	184 ... 380
Power consumption at U_s		0.4 W	0.75 VA	0.75 VA	0.75 VA	0.75 W	1 VA	1 VA	1 VA
Release voltage	V	2.4	7.2	34.5	69	3.6	7.2	34.5	69
Permissible residual current	mA	1.5	4.2	0.8	0.4	2.8	8.8	1.9	1.0
Protection circuit		Freewheel diode for complete unit	No			Freewheel diode in LED module	No		
Max. permissible cable length at U_s ²⁾ (min. cross-section: 0.75 mm ²)	m	> 2000	30 (with LED), 20 (without LED)			> 2000	500	200	50
Load side									
Switching voltage AC/DC	V	24 ... 250				24 ... 250			
Rated currents³⁾									
• Continuous thermal current I_{th}	A	16/8 (1 CO/2 CO)				12/10/6 (2 CO/3 CO/4 CO)			
• Rated operational current I_e AC-15 acc. to utilization categories (EN 60947)	A	6/3				5/5/4			
• Rated operational current I_e DC-13 acc. to utilization categories (EN 60947)	A	2 at 24 V 0.27 at 230 V				5 at 24 V 0.5 at 230 V			
Short-circuit protection $I_k \geq 1$ kA acc. to IEC 60947-5-1 Fuse links gL/gG operational class DIAZED	A	10				6			
Shock resistance Half-sine acc. to IEC 60028-2-27	g/ms	10/11				9/11			
Vibration resistance									
Floating sine acc. to IEC 60068-2-6; 30 ... 150 Hz									
• Opening the normally-closed contacts along the critical axis	g	5				Approx. 7			
• Closing the normally-open contacts	g	> 20				> 20			
Min. contact load (reliability: 1 ppm)		Standard 17 V, 10 mA; hard gold-plated 17 V/0.1 mA				Standard 17 V, 10 mA; hard gold-plated 20 mV/1 mA			
Mechanical endurance	Operating cycles	30 x 10 ⁶	10 x 10 ⁶			10 x 10 ⁶			
Electrical endurance (resistive load at 250 V AC)	Operating cycles	1 x 10 ⁵				1 x 10 ⁵			
Switching frequency (operating cycles)									
• Without load	1/min 1/h	1200 72000				600 36000			
• With load	1/min 1/h	6 360				6 360			
Make-time	ms	7				15			
Break-time	ms	3				10			
Bounce time	ms	2				5			
Contact material		AgNi 90/10							

¹⁾ AC voltages, 50 Hz; for 60 Hz operation, the lower response value must be increased by 10 %; the power loss will reduce slightly.

²⁾ The max. cable length depends on the conductor capacity and the cable installation. It can be increased by means of parallel load on A1/A2.

³⁾ Capacitive loads can result in micro-weldings on the contacts.

Coupling Relays with LZS, LZX Plug-in Relays

Plug-in relay couplers

Relay type	MT industrial relay, 11-pole (35.5 mm) 3 CO				
AC and DC operation					
Rated control supply voltage $U_s^{1)}$	V	24 DC	24 AC	115 AC	230 AC
Rated insulation voltage U_i Degree of pollution	V	250 3			
Overvoltage category Acc. to EN 60664-1		III			
Protective separation Between the coil and the contacts Acc. to EN 60947-1, Appendix N		No			
Degree of protection of relay/base		IP50/IP20			
Permissible ambient temperature					
• During operation	°C	-40 ... +60	-45 ... +50	-45 ... +50	-45 ... +50
• During storage	°C	-45 ... +80	-45 ... +80	-45 ... +80	-45 ... +80
Conductor cross-sections					
• Screw terminals					
- Solid	mm ²	2 x 2.5			
- Finely stranded with or without end sleeve	mm ²	2 x 1.5			
- Permissible opening tool		Screwdriver size 1 or Pozidriv 1			
Control side					
Operating range					
• At 20 °C	V	18 ... 38	19.2 ... 38	92 ... 137	184 ... 264
Power consumption at U_s		1.2 W	2.3 VA	2.3 VA	2.3 VA
Release voltage	V	2.4	9.6	46	92
Permissible residual current	mA	4.5	29.2	6.2	3.0
Protection circuit		No			
Max. permissible cable length at $U_s^{2)}$ (min. cross-section: 0.75 mm ²)	m	> 2000	On request	On request	80
Load side					
Switching voltage					
• AC/DC	V	24 ... 250			
Rated currents³⁾					
• Continuous thermal current I_{th}	A	10			
• Rated operational current I_o /DC-13 acc. to utilization categories (EN 60947)	A	2 at 24 V 0.27 at 230 V			
• Rated operational current I_o /AC-15 acc. to utilization categories (EN 60947)	A	5 at 24 V and 230 V			
Short-circuit protection $I_k \geq 1$ kA acc. to IEC 60947-5-1 Fuse links gL/gG operational class DIAZED	A	10			
Shock resistance Half-sine acc. to IEC 60028-2-27	g/ms	13/11			
Vibration resistance					
Floating sine acc. to IEC 60068-2-6 30 ... 150 Hz					
• Opening the normally-closed contacts along the critical axis	g	2			
• Closing the normally-open contacts	g	> 20			
Min. contact load (reliability: 1 ppm)		12 V DC/10 mA			
Mechanical endurance	Oper- ating cycles	20 x 10 ⁶			
Electrical endurance (resistive load at 250 V AC)	Oper- ating cycles	4 x 10 ⁵			
Switching frequency (operating cycles)					
• Without load	1/min 1/h	100 6000			
• With load	1/min 1/h	20 1200			
Make-time	typ./ms	12			
Break-time	typ./ms	5			
Bounce time	typ./ms	4			
Contact material		AgNi 90/10			

1) AC voltages, 50 Hz; for 60 Hz operation, the lower response value must be increased by 10 %; the power loss will reduce slightly.

2) The max. cable length depends on the conductor capacity and the cable installation. It can be increased by means of parallel load on A1/A2.

3) Capacitive loads can result in micro-weldings on the contacts.

Coupling Relays with LZS, LZX Plug-in Relays

Plug-in relay couplers

More information

Notes on configuration

PT series

Mounting the LZS:PT17024 fixing/ejection bracket on the LZS:PT787.0 standard plug-in base with screw terminals

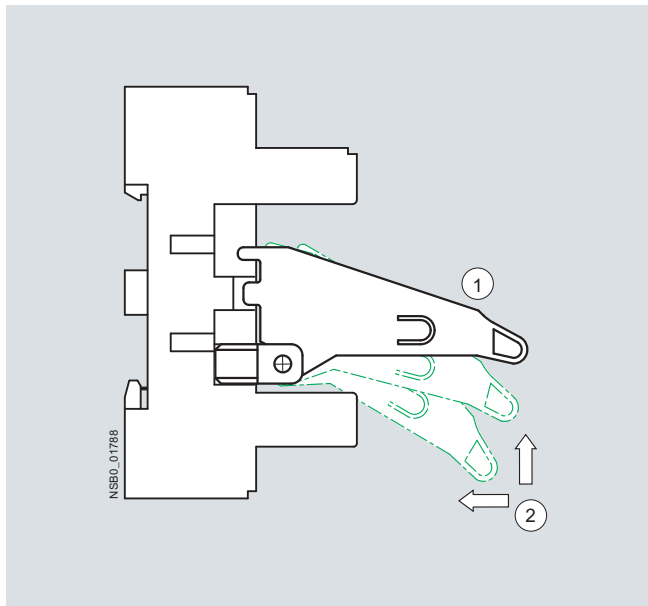

Legend:

- ① Locking position
- ② Mounting direction

Mounting the coupling relays with plug-in relay

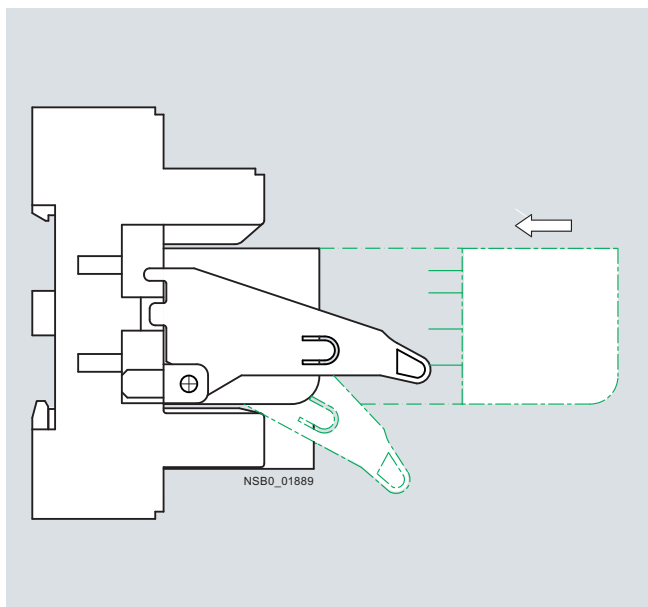

Important:
The LZS:PT17021 and LZS:PT17024 ejection brackets of the coupling relays with plug-in relay are not status displays!

RT series

Mounting the LZS:RT17016 fixing/ejection bracket on the LZS:RT7872. plug-in base

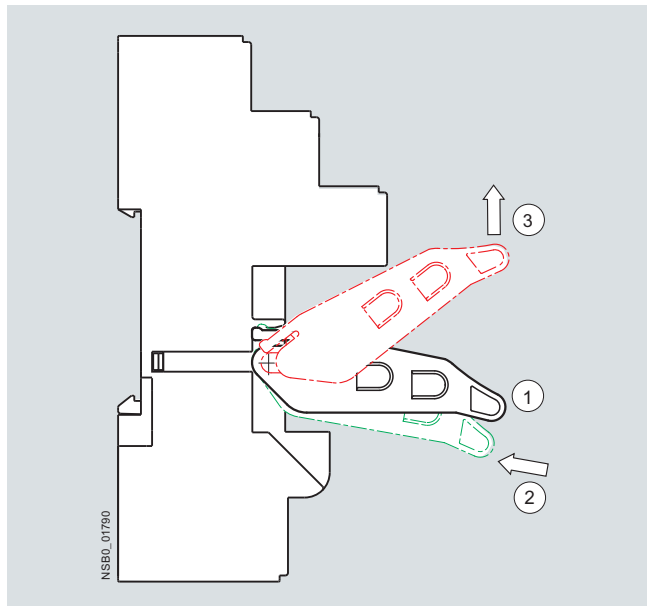

Legend:

- ① Locking position
- ② Mounting direction
- ③ Demounting direction

Mounting the coupling relays with plug-in relay

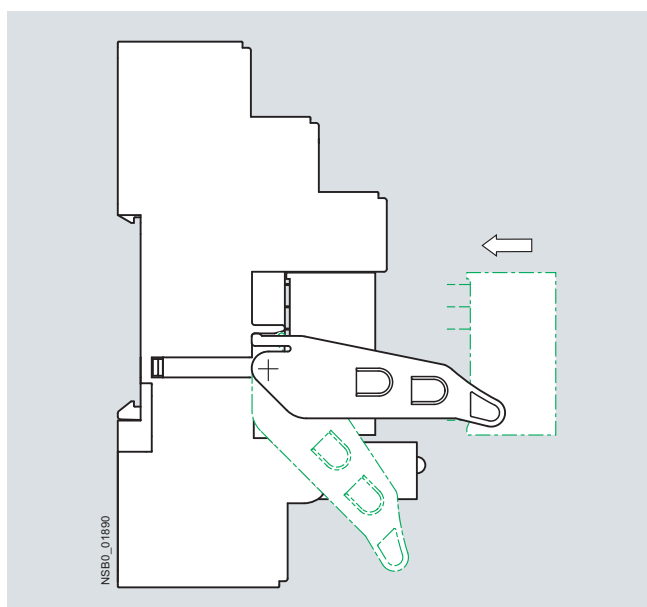

Important:
The LZS:RT17016 ejection brackets of the coupling relays with plug-in relay are not status displays!

3TG10 Power Relays/Miniature Contactors

4-pole, 4 kW

Overview

Version

The 3TG10 power relays/miniature contactors with 4 main contacts are available with 6.3 mm × 0.8 mm screw terminals or flat connectors. The versions with screw terminals are climate-proof and finger-safe according to EN 61140.

The 3TG10 power relays/miniature contactors are small. The overall width is 36 mm.

Technical specifications

Type		3TG10	
General data			
Endurance			
• Mechanical	Operating cycles		3 million
• Electrical			
- AC-1 at I_e	Operating cycles		0.1 million
- AC-3 at I_e	Operating cycles		0.4 million
Rated insulation voltage U_i (degree of pollution 3)	V		400
Rated impulse withstand voltage U_{imp}	kV		4
Protective separation			
Between the coil and the contacts acc. to EN 60947-1, Appendix N	V		Up to 300
Permissible ambient temperature			
• During operation ¹⁾	°C		-25 ... + 55
• During storage	°C		-50 ... + 80
Degree of protection acc. to IEC 60947-1 and EN 60529 (VDE 0470 Part 1)			
			IP00, drive system IP20
Power consumption of the magnetic coils (when coil is cold and $1.0 \times U_s$)			
• AC operation 45 ... 450 Hz	VA		4.4
• P.f.			0.9 (hum-free)
• DC operation	W		4
Magnetic coil operating range			
			$0.85 \dots 1.1 \times U_s$
Operating times (Total break time = OFF-delay + Arcing time)			
• ON-delay			
- Closing NO	DC operation	ms	11 ... 50
	AC operation	ms	10 ... 50
- Opening NC	DC operation	ms	21 ... 39
	AC operation	ms	20 ... 30
• OFF-delay			
- Closing NC	DC operation	ms	5 ... 45
	AC operation	ms	5 ... 45
- Opening NO	DC operation	ms	19 ... 35
	AC operation	ms	20 ... 30
• Arcing time			
		ms	10 ... 15
Shock resistance			
• Rectangular pulse	AC operation and DC operation	g/ms	5.1/5 and 3.5/10
• Sine pulse	AC operation and DC operation	g/ms	7.9/5 and 5.2/10
Switching frequency z in operating cycles/hour rated operation			
	Acc. to AC-1	1/h	1000
	Acc. to AC-2	1/h	500
	Acc. to AC-3	1/h	1000
	No-load switching frequency	1/h	10000
Short-circuit protection			
Fuse links			
gL/gG operational class LV HRC 3NA, DIAZED 5SB, NEOZED 5SE acc. to IEC 60947-4-1 (VDE 0660 Part 102)			
	• Type of coordination "1"	A	25
	• Type of coordination "2"	A	10
Miniature circuit breakers	C Characteristic	A	10
AC capacity			
Utilization category AC-1, switching resistive loads			
Rated operational current I_e up to 400 V at 55 °C ¹⁾	A		20 for screw terminals, 16 for flat connector
Rated power U_e for AC loads with p.f. = 1, 230/220 V			
• For screw terminals	kW		7.5 (13 at 400 V)
• For flat connector	kW		6 (10 at 400 V)
Minimum conductor cross-section for load with I_e	mm ²		2.5
Utilization category AC-2 and AC-3			
Operational current for AC-3 at 400 V rated value	A		8.4
Rated power for slipring or squirrel-cage motors with 50 Hz and 60 Hz and at 400 V	W		4000
Utilization category AC-5a (permissible nominal impedance: $\geq 0.5 \Omega$)			
Switching gas discharge lamps			
Per main current path at 230 V, 50 Hz			
Rated power/rated operational current per lamp			
• Uncorrected	18 W	0.37 A	43
	36 W	0.43 A	37
	58 W	0.67 A	24
• DUO switching	18 W	2 x 0.11 A	2 x 81
	36 W	2 x 0.21 A	2 x 42
	58 W	2 x 0.32 A	2 x 28

¹⁾ If the three main current paths carry a load of 20 A, the following applies if $I > 10$ A for the fourth conducting path: permissible ambient temperature 40 °C.

Accessories and Spare Parts

For 3RT, 3RH Contactors and Contactor Relays

Accessories for 3RT, 3RH contactors and contactor relays

Overview

Snap-on auxiliary switch blocks

The auxiliary switch blocks and the maximum number of blocks that can be mounted are described in the sections "Motor Contactors" and "Contactor Relays".

Solid-state time-delay auxiliary switch block

The timer module, which is available in the "ON-DELAY" and "OFF-DELAY" versions, allows time-delayed functions up to 100 s (3 distinct delay ranges).

It contains a relay with one NO contact and one NC contact; depending on the version, the relay is switched either after an ON-delay or after an OFF-delay.

The timer module with "WYE-DELTA FUNCTION" is equipped with one delayed and one instantaneous NO contact, with a dead time of 50 ms between the two. The delay time of the NO contact can be adjusted between 1.5 s and 30 s.

Wye-delta function:

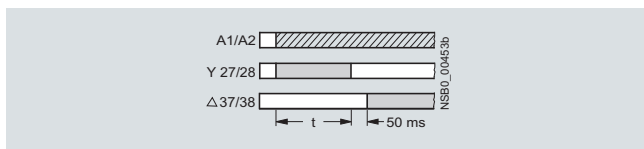

The contactor on which the solid-state, time-delay auxiliary switch block is mounted operates without a delay.

Size S00

The solid-state, time-delay auxiliary switch block is fitted onto the front side of the contactor. The timer module is supplied with power directly by plug-in contacts through the coil terminals of the contactor, in parallel with A1/A2. The timing function is activated by closing the contactor on which the auxiliary switch block is mounted. The OFF-delay version operates without an auxiliary voltage; minimum ON period: 200 ms.

A varistor is integrated in the timer module in order to damp opening surges in the contactor coil.

The solid-state, time-delay auxiliary switch block cannot be mounted on size S00 coupling relays.

Sizes S0 to S12

The solid-state, time-delay auxiliary switch block is fitted onto the front side of the contactor.

The timer module is supplied with power through two terminals (A1/A2); the time delay of the auxiliary switch block can be activated either by a parallel link to any contactor coil or by any power source.

The OFF-delay version operates without an auxiliary voltage; minimum ON period: 200 ms.

A single-pole auxiliary switch block can be snapped onto the front of the contactor in addition to the timer module.

The timer module has no integrated components for overvoltage damping.

Solid-state timing relay block with semiconductor output

The timer module in the "ON-DELAY" and "OFF-DELAY" with auxiliary voltage" versions allows time-delayed functions up to 100 s (3 distinct delay ranges). Contactors fitted with a timing relay block close or open after a delay according to the set time.

The ON-delay variant of the timing relay is connected in series with the contactor coil; terminal A1 of this coil must not be connected.

With the OFF-delay variant of the timing relay, the contactor coil is contacted directly through the relay; terminals A1 and A2 of the contactor coil must not be connected.

The timing relays are suitable for both AC and DC operation.

Size S00

The version for size S00 contactors is fitted onto the front of the contactor (with the supply voltage switched off) and then slid into its latched position; at the same time, the timing relay is connected by means of plug-in contacts to coil terminals A1 and A2 of the contactor. Any contactor coil terminals which are not required are sealed off by means of covers on the enclosure of the timing relay block, to prevent them from being connected inadvertently.

A varistor is integrated in the timer module in order to damp opening surges in the contactor coil.

The solid-state, timing relay block cannot be mounted on size S00 coupling relays.

Sizes S0 to S3

The timing relay block for size S0 to S3 contactors is plugged into coil terminals A1 and A2 on top of each contactor; the timing relay is connected both electrically and mechanically by means of pins.

A varistor is integrated in the timer module in order to damp opening surges in the contactor coil.

Configuring note:

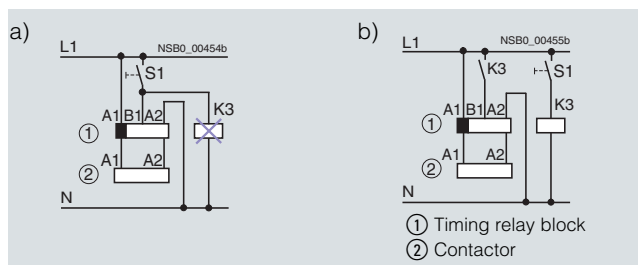

The activation of loads parallel to the start input is not permissible when using AC control voltage (see (a) in the circuit diagram).

The 3RT19 16-2D.../3RT19 26-2D... OFF-delay time relay blocks have a zero potential start input B1. This means that if there is a parallel load on terminal B1, activation can be simulated with AC voltage. In this case, the additional load (e. g. contactor K3) must be wired according to (b).

OFF-delay device for size S00 to S3 contactors

AC and DC operation

IEC 60947, EN 60947.

For screw and snap-on mounting onto 35 mm standard mounting rail. The OFF-delay devices have screw terminals.

The OFF-delay device prevents a contactor from dropping out unintentionally when there is a short-time voltage dip or voltage failure. It supplies a downstream, DC-operated contactor with the necessary energy during a voltage dip, ensuring that the contactor does not trip. The 3RT19 16 OFF-delay devices are specifically designed for operation with the 3RT contactors and 3RH contactor relays of the SIRIUS series.

The OFF-delay device operates without external voltage on a capacitive basis, and can be energized with either AC or DC (24 V version only for DC operation). Voltage matching, which is only necessary with AC operation, is performed using a rectifier bridge.

A contactor opens after a delay when the capacitors of the magnetic coil, built into the OFF-delay device, are switched in parallel. In the event of voltage failures, the capacitors are discharged via the magnetic coil and thereby delay the opening of the contactor.

Accessories and Spare Parts

For 3RT, 3RH Contactors and Contactor Relays

Accessories for 3RT, 3RH contactors and contactor relays

If the command devices are upstream of the OFF-delay device in the circuit, the OFF-delay takes effect with every opening operation. If the opening operation is downstream of the OFF-delay device, an OFF-delay only applies in the event of failure of the mains voltage.

Operation

In the case of the versions for rated control supply voltages of 110 V and 230 V, either AC voltage or DC voltage can be applied on the line side, whereas the variant for 24 V is designed for DC operation only.

A DC-operated contactor is connected to the output in accordance with the input voltage that is applied.

The mean value of the OFF-delay is approximately 1.5 times the specified minimum time.

Surge suppressors

- Without LED (also for Cage Clamp terminals) size S00, S0, S2, S3, S6 to S12
- With LED (also for Cage Clamp terminals) size S00

All 3RT1 contactors and 3RH1 contactor relays can be retrofitted with RC elements or varistors for damping opening surges in the coil. Diodes or diode assemblies (comprising noise suppression diodes and Zener diodes for rapid switch-off) can be used.

The surge suppressors are plugged onto the front of size S00 contactors. Space is provided for them next to a snap-on auxiliary switch block.

With all size S0 to S3 contactors, varistors, RC elements and diode assemblies can be plugged on directly at the coil terminals, either on the top or underneath.

The plug-in direction of the diodes and diode assemblies is determined by a coding device.

Coupling relays are supplied either without overvoltage damping or with a varistor or diode connected as standard, according to the version.

Note:

The OFF-delay times of the NO contacts and the ON-delay times of the NC contacts increase if the contactor coils are damped against voltage peaks (noise suppression diode 6 to 10 times; diode assemblies 2 to 6 times, varistor +2 to 5 ms).

Electromagnetic interference suppression module, 3-phase for size S00 contactors

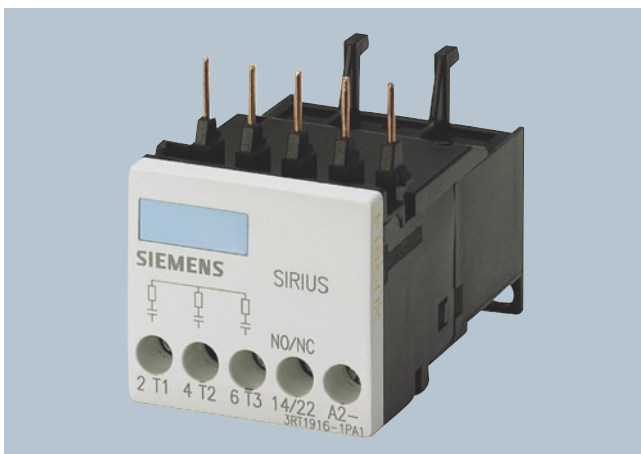

A so-called counter-e.m.f. (electromotive force) is produced when motors or various inductive loads are turned off. Voltage peaks of up to 4000 V may occur as a result, with a frequency spectrum from 1 kHz to 10 MHz and a rate of voltage variation from 0.1 to 20 V/ns.

Capacitive input to various analog and digital signals makes it necessary to suppress interference in the load circuit.

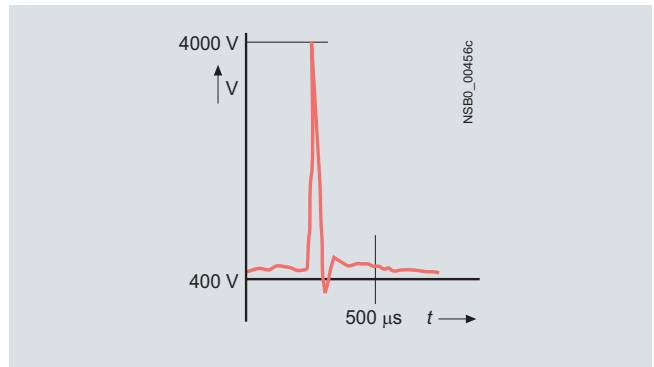

Reducing contact arcing

The connection between the main current path and the EMC interference suppression module enables contact arcing, which is responsible for contact erosion and the majority of clicking noises, to be reduced; this in turn is conducive to an electromagnetically compatible design.

Higher operational reliability

Since the EMC interference suppression module achieves a significant reduction in radio-frequency components and the voltage level in three phases, the contact endurance is also improved considerably. This makes an important contribution towards enhancing the reliability and availability of the system as a whole.

Dispensing with fine graduations

There is no need for fine graduations within each performance class, as smaller motors inherently have a higher inductance, so that one solution for all fixed-speed operating mechanisms up to 5.5 kW is adequate.

Two electrical versions are available:

- The advantages of the RC circuit lie mainly in the reduction in the rate of rise and in its RF damping ability. The selected values ensure effective interference suppression over a wide range.

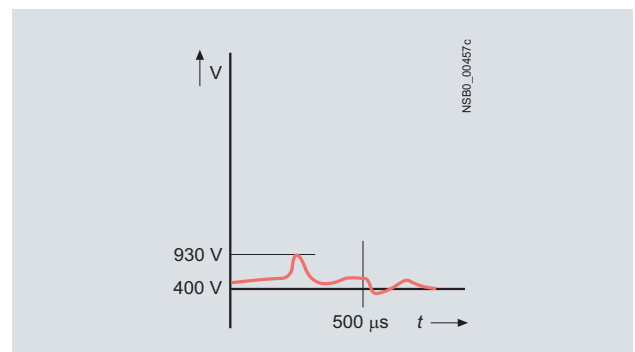

- The varistor circuit can absorb a high energy level and can also be used for frequencies ranging from 10 to 400 Hz (closed-loop controlled operating mechanisms). There is no limiting below the knee-point voltage, however.

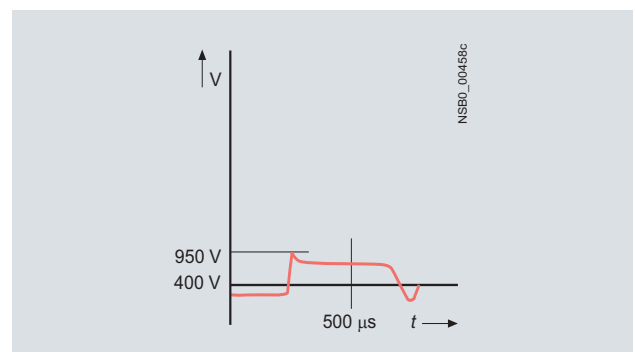

Accessories and Spare Parts

For 3RT, 3RH Contactors and Contactor Relays

Accessories for 3RT, 3RH contactors and contactor relays

Additional load module

Size S00 for plugging onto the front of the contactors with and without auxiliary switch block

Coupling links for mounting on contactors of sizes S0 to S3

DC operation

IEC 60947 and EN 60947.

The coupling link is suitable for use in any climate. It is finger-safe according to EN 50274. The terminal designations comply with EN 50005.

System-compatible operation with 24 DC V, operating range 17 to 30 V.

Low power consumption in conformity with the technical specifications of the solid-state systems. An LED indicates the switching state.

Surge suppression

The 3RH19 24-1GP11 coupling link has an integrated surge suppressor (varistor) for the contactor coil being switched.

Mounting

The 3RH19 24-1GP11 coupling link is mounted directly on the contactor coil.

Solder pin adapters

The solder pin adapters for the size S00 contactors are available in two versions:

- Solder pin adapter for contactors with one integrated auxiliary contact
- Solder pin adapter for contactors with mounted 4-pole auxiliary switch block

Screw adapters

Plug-on adapters improve the accessibility of the screw fixing for size S0 contactors. As a result it is possible to position the screwdriver vertically even when using insulated screwdrivers or power screwdrivers.

Optionally the adapters can be rotated through 90° before mounting.

Sealable covers for sizes S00 to S12

When contactors and contactor relays are used in safety-oriented applications, it must be ensured that it is impossible to operate the contactors manually.

For SIRIUS contactors there are sealable covers available for this purpose as accessories; these prevent accidental manual operation. These are transparent molded-plastic caps with a bracket that enables the contactor to be sealed.

Technical specifications

Technical specifications according to EN 61812-1 (VDE 0435 Part 2021)

Contactors	Type	3RT19 26-3A Mechanical latching block for the 3RT1. 2. and 3RT1. 3. contactors	
Rated insulation voltage U_i (degree of pollution 3)	V	690	
Mechanical endurance (operating cycles)	<ul style="list-style-type: none"> • With 3RT1. 2 • With 3RT1. 3 	3 million 50 000	
Permissible ambient temperature			
• During operation	°C	-25 ... +60	
• During storage	°C	-50 ... +80	
Degree of protection acc. to EN 60947-1, Appendix C		IP20	
Operating range of the magnetic coil At AC 50/60 Hz and DC		0.85 ... 1.1 x U_s	
Power consumption of the magnetic coils of the unlocking magnet (for cold coil and 1.0 x U_s) AC and DC operation	W	Approx. 4	
Command duration for de-energizing			
• AC operation	ms	18 ... 31	
• DC operation	ms	18 ... 26	
Conductor cross-sections			
• Solid	mm ² AWG	2 x (0.5 ... 2.5); 1 x 4 2 x 14; 1 x 12	
• Finely stranded with end sleeve	mm ² AWG	2 x (0.5 ... 2.5); 1 x 2.5 2 x 14; 1 x 12	
Tightening torque of the terminal screws	Nm lb.in	0.8 ... 1.1 7 ... 9.5	

Accessories and Spare Parts



For 3RT, 3RH Contactors and Contactor Relays

Accessories for 3RT, 3RH contactors and contactor relays

Contactor	Type		3RT19 .6-2C Solid-state time-delay blocks with semi-conductor output	3RT19 .6-2D 3RT19 .6-2L 3RT19 .6-2E 3RT19 .6-2F 3RT19 .6-2G Solid-state time-delay auxiliary switch blocks
Rated insulation voltage U_i Degree of pollution 3 Overvoltage category III acc. to EN 60664-1		V AC	250	300 250
Operating range of excitation			0.8 ... 1.1 x U_{S1} 0.95 ... 1.05 times rated frequency	0.85 ... 1.1 x U_{S1} 0.95 ... 1.05 times rated frequency
Rated power • Power consumption at 230 V AC, 50 Hz		W VA	1 1	2 4
Rated operational currents I_e • AC-140, DC-13 • AC-15, 230 V, 50 Hz • DC-13, 24 V • DC-13, 110 V • DC-13, 230 V		A A A A A A	0.3 for 3RT19 16 0.3 for 3RT19 26 -- -- -- --	-- -- 3 1 0.2 0.1
DIAZED protection gL/gG operational class		A	--	4
Switching frequency for load • With I_e 230 V AC • With 3RT10 16 contactor, 230 V AC		h^{-1} h^{-1}	2500 2500	5000
Recovery time		ms	50	150
Minimum ON period		ms	35	35 (OFF-delay with auxiliary voltage) 200 (with OFF-delay)
Residual current	Max.	mA	5	--
Voltage drop With conducting output	Max.	VA	3.5	--
Short-time loading capacity	Up to 10 ms	A	10	--
Setting accuracy With reference to upper limit of scale	Typ.	%	±15	
Repeat accuracy	Max.	%	±1	
Mechanical endurance		Oper-ating cycles	100 x 10 ⁶	10 x 10 ⁶
Permissible ambient temperature • During operation • During storage		°C °C	-25 ... +60 -40 ... +80	
Degree of protection acc. to EN 60947-1, Appendix C • Cover • Terminals			IP40 IP20	
Conductor connections • Solid • Finely stranded with end sleeve • AWG cables, solid or stranded • Terminal screws • Tightening torque		mm ² mm ² AWG M3 Nm	2 x (0.5 ... 1.5), 2 x (0.75 ... 4) 2 x (0.5 ... 2.5) 2 x (18 ... 14) M3 0.8 ... 1.2	
Permissible mounting position			Any	
Shock resistance Half-sine acc. to IEC 60068-2-27		g/ms	15/11	
Vibration resistance Acc. to IEC 60068-2-6		Hz/mm	10 ... 55/0.35	
EMC tests	Basic specification		IEC 61000-6-4	IEC 61000-6-2; IEC 61000-6-4 IEC 61000-6-4
Overvoltage protection			Varistor integrated in timing relay	--

Accessories and Spare Parts For 3RT, 3RH Contactors and Contactor Relays

Accessories for 3RT, 3RH contactors and contactor relays

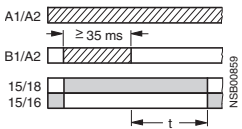
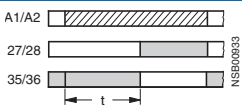
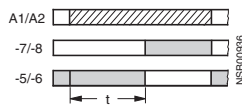
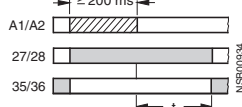
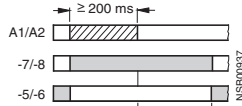
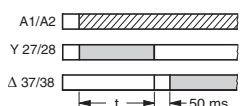
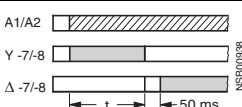
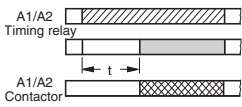
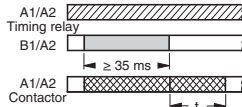
Function table 3RT19 16, 3RT19 26	Function chart	3RT19 16 timing relays					3RT19 26 timing relays					
Function	 Timing relay energized  Contact closed  Contact open	3RT19 16-2C	3RT19 16-2D	3RP19 16-2E	3RT19 16-2F	3RT19 16-2G	3RT19 16-2L	3RT19 26-2C	3RT19 26-2D	3RT19 26-2E	3RT19 16-2F	3RT19 26-2G
1 CO contact												
OFF-delay With auxiliary voltage							✓					
1 NO contact + 1 NC contact												
ON-delay (varistor integrated)			✓									
With ON-delay									✓			
OFF-delay Without auxiliary voltage (varistor integrated)					✓							
OFF-delay without auxiliary voltage										✓		
2 NO contacts												
Wye-delta function (varistor integrated) 1 NO delayed, 1 NO instantaneous, dead time 50 ms						✓						
Wye-delta function 1 NO delayed, 1 NO instantaneous, dead time 50 ms											✓	
1 NO contact (semiconductor)												
ON-delay Two-wire version (varistor integrated)		✓						✓				
OFF-delay With auxiliary voltage (varistor integrated)			✓						✓			

✓ Function is possible.

Accessories and Spare Parts

For 3RT, 3RH Contactors and Contactor Relays

Accessories for 3RT, 3RH contactors and contactor relays

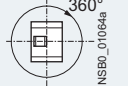
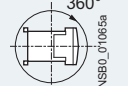
Versions		3RT19 16-2BE01 OFF-delay devices	3RT19 16-2BK01	3RT19 16-2BL01
Connectable contactor sizes Caution! Only contactors and contactor relays with DC operation can be connected.		S00 ...S3	S00/S0	S00/S0
• DC supply		--	S00/S0	S00/S0
• AC supply	Type	3RT10 ...-1BB4., 3RH1 ...-1BB40	3RT10 1.-1BF4, 3RT10 2.-1BF4, 3RH1 ...-1BF40	3RT10 1.-1BM4./1BP4., 3RT10 2.-1BM4./1BP4., 3RH1 ...-1BM40/1BP40
Permissible mounting position				
Rated control supply voltage U_s Operating range	V	24 (DC) 0.9 ... 1.1 U_s	110 (UC)	220/230 (UC)
Rated frequency/ies with AC supply	f	Hz $\pm 5\%$	50/ 60	50/ 60
Ambient temperature permissible:				
• During operation				
- Side-by-side mounting without distance	T_u	°C	-25 ... +50	
- Side-by-side mounting with 5 mm distance	T_u	°C	-25 ... +60	
• During storage	T_u	°C	-40 ... +80	
OFF-delay¹⁾ (minimum times at $U_{sp} = 0.9 \times U_s$, $T_{sp} = 20$ °C)			Note: In practice the mean value is 1.5 times the minimum time.	
• S00	$t_{off} >$	ms	250	600
• S0	$t_{off} >$	ms	150	400
• S2 (only for DC supply)	$t_{off} >$	ms	90	--
• S3 (only for DC supply)	$t_{off} >$	ms	70	--
Installed capacity C 3RT19 16-2B.01	μF	2000	68	68
Capacitor voltage	V	35	180	350
ON-delay (maximum at $U_{sp} = 0.9 \times U_s$, $T_{sp} = 20$ °C)			Note: The total ON-delay = Contactor make-time + t_{on}	
• S00	$t_{on} <$	ms	10	200
• S0	$t_{on} <$	ms	10	250
Mechanical endurance	Operating cycles		30 million	
Endurance, electrical approx.	Operating cycles		> 1 million	
Switching frequency z max. (at $T_u = 60$ °C)	h^{-1}		300	
Power loss P_V max. approx.	W		0.4	1
Surge suppression			with varistor, integrated	
Conductor cross-sections U_{sp} = Coil voltage T_{sp} = Coil temperature			2)	

1) Doubling the delay time can be achieved by doubling the capacitance.
Commercially available capacitors can be used, which can be connected to terminals C+ and Z-.

2) See 3RT10 1 contactors, page 3/23.

Accessories and Spare Parts

For 3RT, 3RH Contactors and Contactor Relays

Accessories for 3RT, 3RH contactors
and contactor relays

Contactors	Type	3RT19 26-2P. Pneumatic delay block ¹⁾	
General data			
Mechanical endurance	Operating cycles	5 million	
Electrical endurance at I_e	Operating cycles	1 million	
Rated insulation voltage U_i (degree of pollution 3)	V	690	
Permissible ambient temperature			
• During operation	°C	-25 ... +60	
• During storage	°C	-50 ... +80	
Rated operational currents I_e Acc. to utilization categories EN 60947			
• AC-12	A	10	
• AC-15/AC-14 at U_e	Up to 230/220 V A	6	
	400/380 V A	4	
	500 V A	2.5	
	690/660 V A	1.5	
• DC-13 at U_e	24 V A	4	
	48 V A	2	
	110 V A	0.7	
	220 V A	0.3	
	440 V A	0.15	
Conductor cross-sections			
• Solid, stranded:	mm ²	2 x 0.5 ... 2.5 ²⁾ or 2 x 2.5 ... 4 ²⁾	
• Finely stranded with end sleeve	mm ²	2 x 0.5 ... 2.5	
• AWG cables	AWG	2 x 22 ... 12	
• Tightening torque of the terminal screws	Nm	0.8 ... 1.1	
Time delay			
• Accuracy		±10 %	
Ⓢ and Ⓢ rated data			
• Rated voltage	V AC	600	
• Switching capacity		A 600, Q 600	

¹⁾ For size S0.
In addition to the pneumatic delay block, no other auxiliary contacts are permitted.

²⁾ If two different conductor cross-sections are connected to one clamping point, both cross-sections must lie in the range specified. If identical cross-sections are used, this restriction does not apply.

Versions	3RT1900-4RE01 plugs S00, S0		3RT1916-4RD01 adapters S00	3RT1926-4RD01 adapters S0
Connection modules for contactors with screw terminals				
General data				
Mechanical endurance	Operating cycles	10 million		
Electrical endurance at I_e	Operating cycles	1 million		
Rated operational voltage U_e	V	440		
Rated insulation voltage U_i (degree of pollution 3)	V	690		
Rated impulse withstand voltage U_{imp} (degree of pollution 3)	kV	6		
Protective separation acc. to EN 60947-1 (degree of pollution 3)	V	400		
Rated operational current I_e AC-3 at 400 V	A	25	20	25
Rated frequency f For AC operation	Hz	50/60		
Permissible ambient temperature				
• During operation	°C	-25 ... +60		
• During storage	°C	-50 ... +80		
Degree of protection acc. to EN 60529		IP20		
Conductor cross-sections Screw terminals				
• Solid	mm ²	1x (0.5 ... 6)		
• Finely stranded without/with end sleeve	mm ²	1x (0.5 ... 6)		
• Stranded	mm ²	1x (0.5 ... 6)		
• AWG cables, solid or stranded	AWG	1x (20 ... 10)		
• Tightening torque	Nm	0.6 ... 0.8		
• Corresponding opening tool		Short-slot screwdriver PZ2		

Accessories and Spare Parts

For 3RT, 3RH Contactors and Contactor Relays

Accessories for 3RT, 3RH contactors and contactor relays

Versions		3RT1900-4RE01 plugs S00, S0	3RT1916-4RD01 adapters S00	3RT1926-4RD01 adapters S0
Connection modules for contactors with screw terminals				
Ⓢ and Ⓛ rated data				
• Rated operational voltage U_e	V	480		
• Rated insulation voltage U_i	V	600		
• Uninterrupted current, at 40 °C	A	16/25	16	25
• Short-circuit protection ¹⁾				
	• At 600 V	kA	5	
	• CLASS RK5 fuse	A	100	60
	• Circuit breakers with overload protection acc. to UL 489	A	100	60
				100
				100
Combination motor controllers type E Acc. to UL 508				
	• At 480 V	Type	3RV102	
		A	22	--
		kA	65	--
				22
	• At 600 V	Type	3RV102	
		A	22	--
		kA	10	--
				22
				10

¹⁾ For more information about short-circuit values, e. g. for protection against short-circuit currents, see the UL guide (Order No.: A5E02118883) or UL reports (<http://www.siemens.com/lowvoltage/support>) for the individual devices.

Contactor	Type	3RH19 24, 3TX7 090 Coupling links for mounting on contactors acc. to IEC 60947/EN 60947	
General data			
Rated insulation voltage U_i (degree of pollution 3)	V	300	
Protective separation between the coil and the contacts acc. to EN 60947-1, Appendix N	V AC	Up to 300	
Degree of protection acc. to EN 60947-1, Appendix C			
• Terminals		IP20	
• Enclosure		IP40	
Permissible ambient temperature			
• During operation	°C	-25 ... +60	
• During storage	°C	-40 ... +80	
Conductor cross-section			
• Solid	mm ²	2 x (0.5 ... 2.5)	
• Finely stranded with end sleeve	mm ²	2 x (0.5 ... 1.5)	
Terminal screws		M3	
Short-circuit protection (weld-free protection at $I_k \geq 1$ kA) Fuse links, gL/gG operational class LV HRC 3NA, DIAZED 5SB, NEOZED 5SE	A	6	
Control side			
Rated control supply voltage U_s	V DC	24	
Operating range	V DC	17 ... 30	
Power consumption at U_s	W	0.5	
Nominal current input	mA	20	
Release voltage	V	≥ 4	
Function display		LED yellow	
Protection circuit		Varistor	

Accessories and Spare Parts

For 3RT, 3RH Contactors and Contactor Relays

Accessories for 3RT, 3RH contactors
and contactor relays



Contactors	Type	3RH19 24, 3TX7 090 Coupling links for mounting on contactors acc. to IEC 60947/EN 60947	
Load side			
Mechanical endurance	In million operating cycles		20
Electrical endurance at I_e	In million operating cycles		0.1
Switching frequency	Operating cycles	h^{-1}	5000
Make-time		ms	Approx. 7
Break-time		ms	Approx. 4
Bounce time		ms	Approx. 2
Contact material			AgSnO
Switching voltage		V AC/DC	24 ... 250
Permissible residual current of the electronics (for 0 signal)		mA	2.5
Rated operational currents ¹⁾			
Continuous thermal current I_{th}		A	6
Rated operational currents I_e Acc. to utilization categories EN 60947			
• AC-15	- At 24 V	A	3
	- At 110 V	A	3
	- At 230 V	A	3
• DC-13	- At 24 V	A	1
	- At 110 V	A	0.2
	- At 230 V	A	0.1
Switching current with resistive load to EN 60255 (relay standard) and EN 60947			
• AC-12	- At 24 V	A	6
	- At 110 V	A	6
	- At 230 V	A	6
• DC-12	- At 24 V	A	6
	- At 110 V	A	0.3
	- At 230 V	A	0.2 ¹⁾

¹⁾ Capacitive loads can result in micro-weldings on the contacts.

Accessories and Spare Parts For 3T Contactors and Contactor Relays

Accessories for
3TB, 3TC, 3TF, 3TG, 3TK contactors

Technical specifications



For 3TF2 contactors		Auxiliary switch block	
Type		3TX4 4...-..	
General data			
Permissible mounting position	AC and DC operation	Any	
Mechanical endurance		10 million	
• AC operation	Operating cycles	10 million	
• DC operation	Operating cycles	30 million	
Rated insulation voltage U_i (degree of pollution 3)		 For screw terminals	
	V	500	
Rated impulse withstand voltage U_{imp} (degree of pollution 3)		 For screw terminals	
	kV	6	
Protective separation between the coil and the contacts acc. to EN 60947-1, Appendix N	V	Up to 300	
Positively-driven operation		ZH1/457, SUVA	
• 3TF2 basic unit or complete unit		ZH1/457, SUVA	
• 3TF20 basic unit with 3TX4 4 auxiliary switch block	- Upper level - Lower level - Different levels	ZH1/457, SUVA ZH1/457, SUVA SUVA	
Permissible ambient temperature¹⁾			
• During operation	°C	-25 ... +55	
• During storage	°C	-55 ... +80	
Degree of protection acc. to EN 60947-1 Appendix C		IP20 for screw terminals	
Touch protection acc. to EN 50274		Finger-safe for screw terminals	
Shock resistance			
• Rectangular pulse	- AC operation - DC operation	<i>g/ms</i> <i>g/ms</i>	7/5 and 4/10 10/5 and 6/10
• Sine pulse	- AC operation - DC operation	<i>g/ms</i> <i>g/ms</i>	9/5 and 6/10 13/5 and 8/10
Short-circuit protection			
Short-circuit protection			
Fuse links gL/gG LV HRC 3NA, DIAZED 5SB, NEOZED 5SE	A	6	
Weld-free protection at $I_k \geq 1$ kA			

¹⁾ Applies to 50/60 Hz coil:
Operating range at 60 Hz: $0.85 \dots 1.1 \times U_N$;
at 50 Hz, $1.1 \times U_N$, side-by-side mounting and 100 % ON period the max.
ambient temperature is +40 °C.

Accessories and Spare Parts For 3T Contactors and Contactor Relays

Accessories for 3TH contactor relays

Technical specifications

For 3TH2 contactor relays			Auxiliary switch block
Type			3TX4 4...-..
General data			
Permissible mounting position	AC and DC operation		Any
Mechanical endurance			
• AC operation		Operating cycles	10 million
• DC operation		Operating cycles	30 million
Rated insulation voltage U_i (degree of pollution 3)			 For screw terminals
	V		500
Rated impulse withstand voltage U_{imp} (degree of pollution 3)			 For screw terminals
	kV		6
Protective separation between the coil and the contacts acc. to EN 60947-1, Appendix N		V	Up to 300
Positively-driven operation			
• 3TH2 basic unit or complete unit			ZH1/457, SUVA
• 3TH20 basic unit with 3TX4 4 auxiliary switch block	- Upper level - Lower level - Different levels		ZH1/457, SUVA ZH1/457, SUVA SUVA
Permissible ambient temperature¹⁾			
• During operation		°C	-25 ... +55
• During storage		°C	-55 ... +80
Degree of protection acc. to EN 60947-1 Appendix C			IP20 for screw terminals
Touch protection acc. to EN 50274			Finger-safe for screw terminals
Shock resistance			
• Rectangular pulse	- AC operation - DC operation	<i>g</i> /ms <i>g</i> /ms	7/5 and 4/10 10/5 and 6/10
• Sine pulse	- AC operation - DC operation	<i>g</i> /ms <i>g</i> /ms	9/5 and 6/10 13/5 and 8/10
Short-circuit protection			
Short-circuit protection			
Fuse links gL/gG LV HRC 3NA, DIAZED 5SB, NEOZED 5SE		A	6
Weld-free protection at $I_k \geq 1$ kA			

¹⁾ Applies to 50/60 Hz coil
Operating range at 60 Hz: $0.85 \dots 1.1 \times U_N$;
at 50 Hz, $1.1 \times U_N$, side-by-side mounting and 100 % ON period the max.
ambient temperature is +40 °C.

Controls – Contactors and Contactor Assemblies

Project planning aids

Overview

Dimensional drawings

3RA13	3/200 ... 3/202
3RA14	3/203, 3/204
3RA19	3/199, 3/200
3RH11	3/188, 3/191
3RH14	3/191
3RH19	3/196, 3/197
3RS18	3/216
3RT10	3/179 ... 3/184, 3/188 ... 3/190
3RT12	3/185
3RT13	3/185
3RT14	3/181, 3/183, 3/184
3RT15	3/186
3RT16	3/187
3RT19	3/193 ... 3/196, 3/198, 3/204
3TB5	3/207, 3/212
3TC4	3/210, 3/212
3TC5	3/210
3TC7	3/211
3TD68	3/207
3TE68	3/207
3TF2	3/213
3TF6	3/205
3TG10	3/204
3TH2	3/215, 3/216
3TH4	3/192
3TK1	3/208, 3/209
3TK2	3/214
3TX2	3/211
3TX4	3/192, 3/213 ... 3/215
3TX7	3/192, 3/206, 3/217
LZS/LZX	3/218 ... 3/220

Schematics

3RA13	3/237
3RA14	3/238
3RH11	3/226, 3/231, 3/232, 3/235, 3/236
3RH14	3/232, 3/235
3RH19	3/222 ... 3/224, 3/227 ... 3/230
3RS18	3/249
3RT10	3/221, 3/226 ... 3/228, 3/231
3RT12	3/221
3RT13	3/221, 3/228
3RT14	3/221, 3/227
3RT15	3/221, 3/228
3RT16	3/225, 3/230
3RT19	3/222 ... 3/225, 3/229, 3/230
3TB5	3/240, 3/243
3TC4	3/242, 3/244
3TC5	3/242, 3/244
3TC7	3/242, 3/244
3TD68	3/240
3TE68	3/241
3TF2	3/245
3TF6	3/239, 3/243
3TG10	3/239, 3/243
3TH2	3/246
3TH4	3/233, 3/234
3TK1	3/241, 3/244
3TK2	3/245
3TX4	3/245, 3/246
3TX7	3/239, 3/247 ... 3/249
3TY6	3/240
3TY7	3/239
LZS/LZX	3/250, 3/251

Dimensional drawings

3RT10 contactors, 3-pole

3RT10 1 contactors, size S00

Screw terminals
with surge suppressor, auxiliary switch block and mounted overload relay

Lateral distance to
grounded components = 6 mm

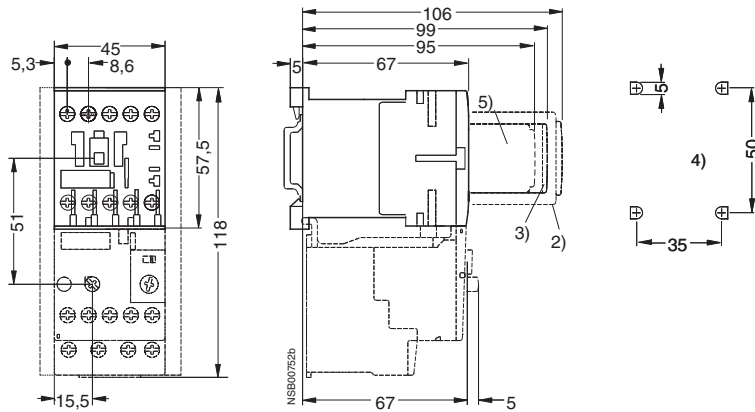

- 2) Auxiliary switch block
(also solid-state compatible version
3RH19 11- . NF . .)
- 3) Surge suppressor
(also 3RT19 16-1GA00
additional load module)
- 4) Drilling pattern
- 5) Auxiliary switch block
1-pole

3RT10 1 contactors, size S00

Cage Clamp terminals with auxiliary switch block

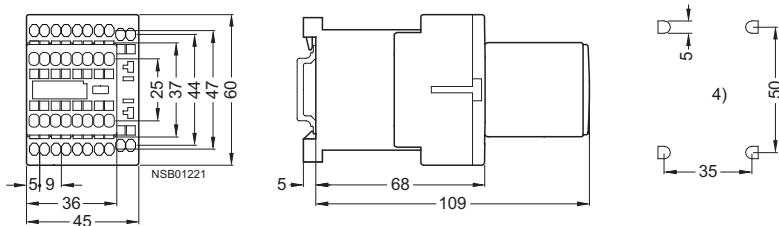

3RT10 2 contactors, 3RT10 2 coupling relays, size S0

Screw terminals
with surge suppressor, auxiliary switch blocks and mounted overload relay

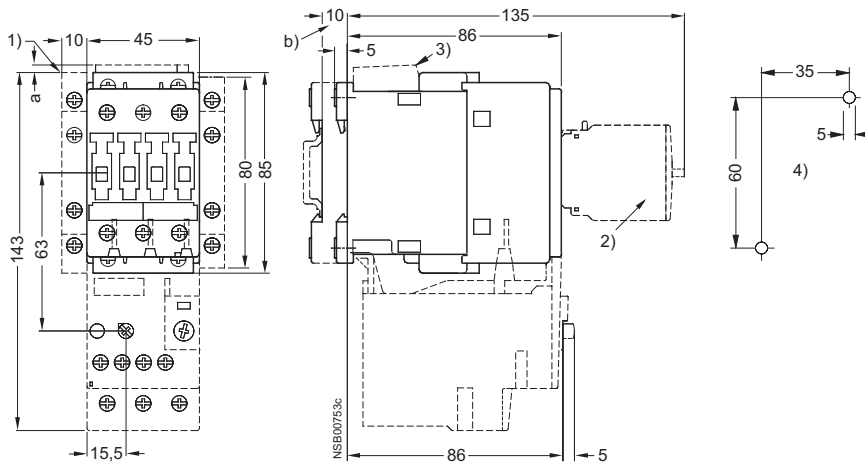

- For size S0:
- a = 3 mm at < 240 V
 - a = 7 mm at > 240 V
 - b = DC 10 mm deeper than AC
- 1) Auxiliary switch block, laterally mountable
 - 2) Auxiliary switch block, mountable on the front,
1-, 2- and 4-pole (also solid-state compatible
version 3RH19 21- . FE22)
 - 3) Surge suppressor
 - 4) Drilling pattern

Project planning aids

3RT10 contactors, 3-pole

3RT10 2 contactors, 3RT10 2 coupling relays, size S0

Cage Clamp terminals
with surge suppressor, auxiliary switch blocks and mounted overload relay

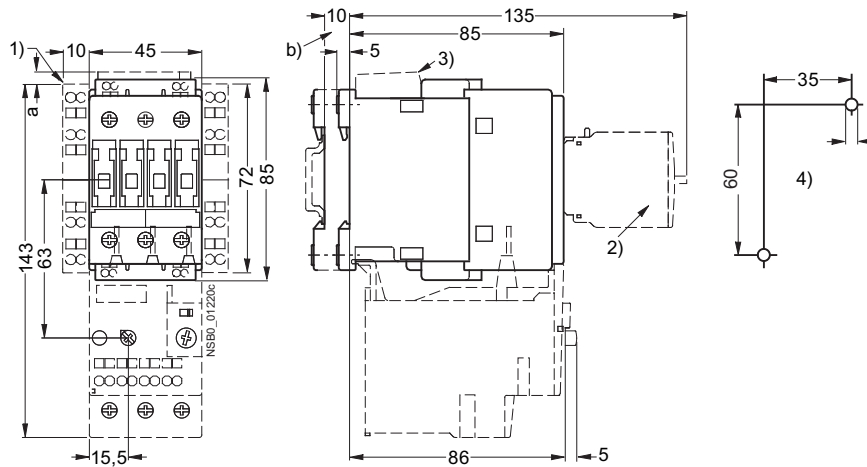

For size S0:

- a = 0 mm with varistor < 240 V, diode assembly
- a = 3.5 mm with varistor > 240 V
- a = 17 mm with RC element
- b = DC 10 mm deeper than AC
- 1) Auxiliary switch block, laterally mountable
- 2) Auxiliary switch block, mountable on the front, (1-, 2- and 4-pole)
- 3) Surge suppressor
- 4) Drilling pattern

3RT10 3 contactors, size S2

Screw terminals
with surge suppressor, auxiliary switch blocks and mounted overload relay

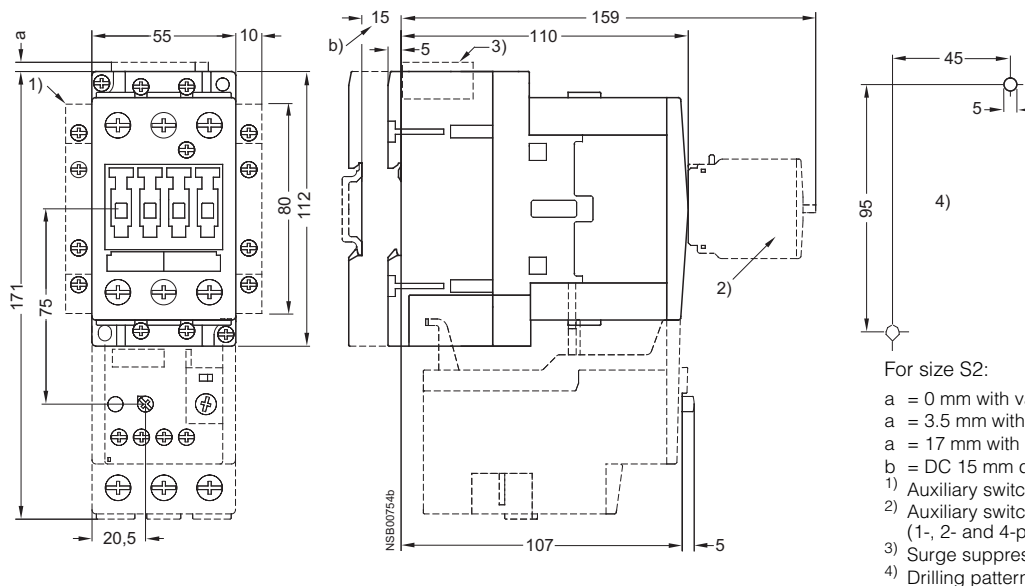

For size S2:

- a = 0 mm with varistor < 240 V, diode assembly
- a = 3.5 mm with varistor > 240 V
- a = 17 mm with RC element
- b = DC 15 mm deeper than AC
- 1) Auxiliary switch block, laterally mountable
- 2) Auxiliary switch block, mountable on the front, (1-, 2- and 4-pole)
- 3) Surge suppressor
- 4) Drilling pattern

3RT10 and 3RT14 contactors, 3-pole**3RT10 3 contactors, size S2**

Cage Clamp terminals
with surge suppressor, auxiliary switch blocks and mounted overload relay

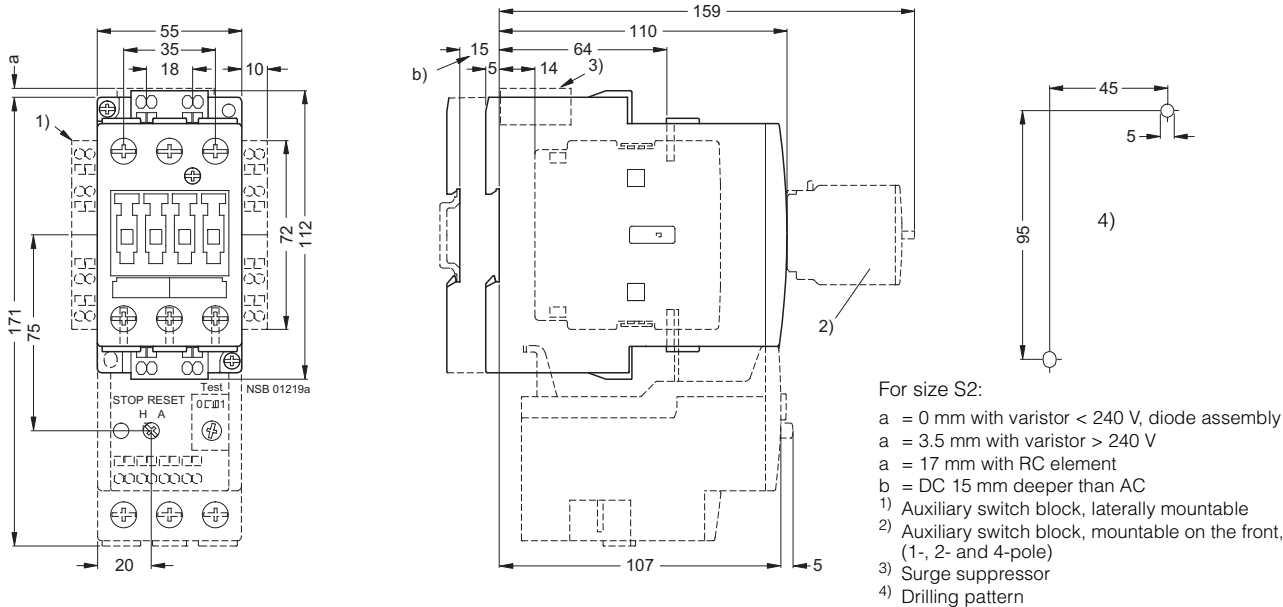
**3RT10 4, 3RT14 46 contactors, size S3**

Screw terminals
with surge suppressor, auxiliary switch blocks and mounted overload relay

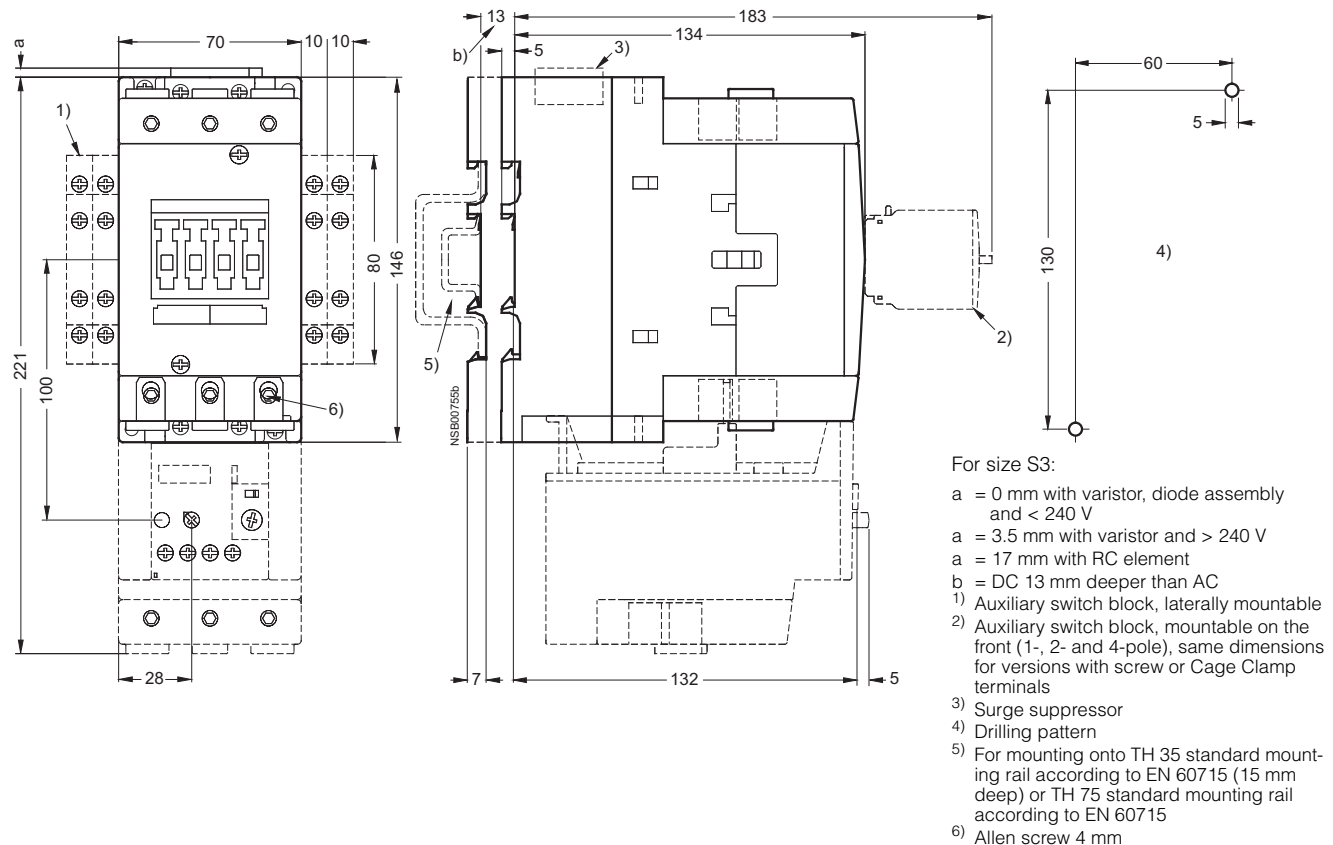

Controls – Contactors and Contactor Assemblies

Project planning aids

3RT10 contactors, 3-pole

3RT10 4 contactors, size S3

Cage Clamp terminals
with surge suppressor, auxiliary switch blocks and mounted overload relay

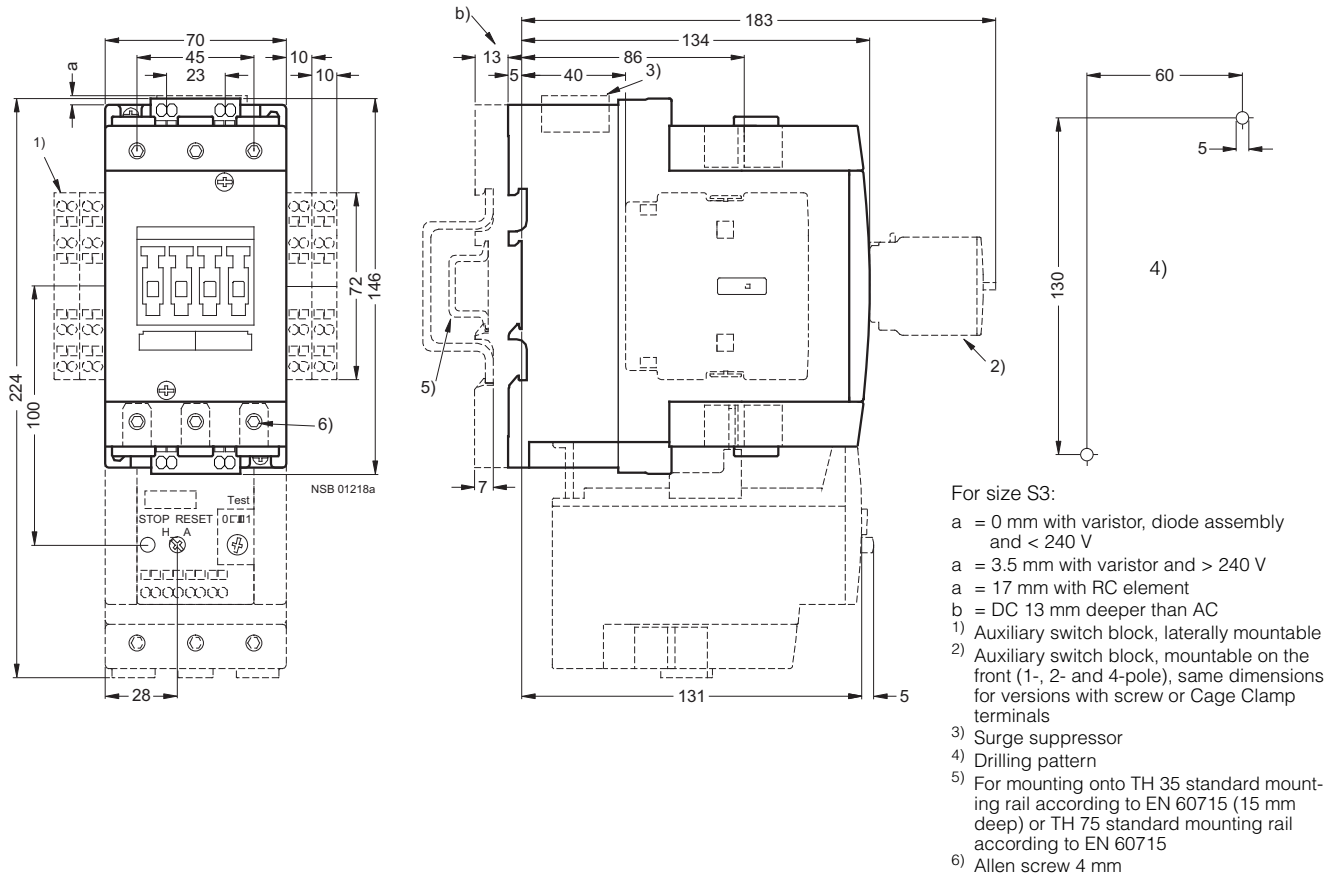

3RT10 coupling relays, size S00

with surge suppressor

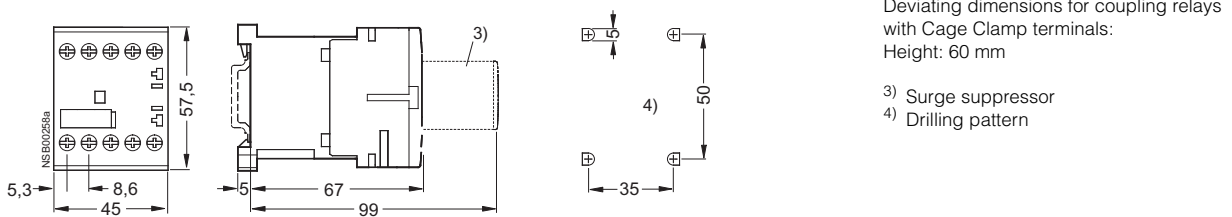

3RT10 and 3RT14 contactors, 3-pole**3RT10 5, 3RT14 5 contactors, size S6**

with lateral and front mounted auxiliary switch block
mounted overload relay and box terminals,
lateral solid-state module with remaining lifetime indicator

Distance from grounded parts

Lateral: 10 mm

Front: 20 mm

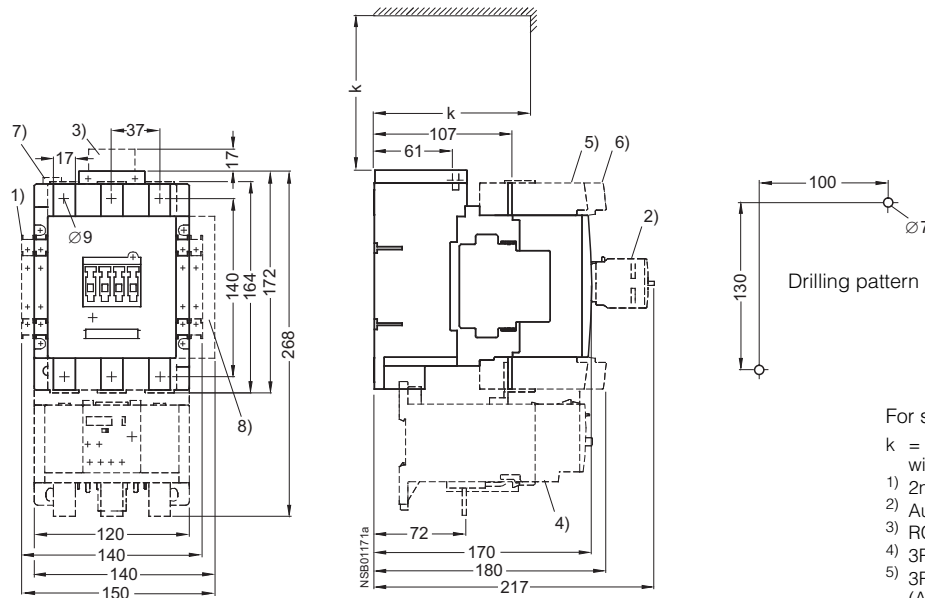

For size S6:

k = 120 mm (minimum clearance for removing the withdrawable coil)

- 1) 2nd auxiliary switch block, lateral
- 2) Auxiliary switch block, mountable on the front
- 3) RC element
- 4) 3RB20 overload relay, mounted
- 5) 3RT19 55-4G box terminal block (Allen screw 4 mm)
- 6) 3RT19 56-4G box terminal block (Allen screw 4 mm)
- 7) PLC connection 24 V DC and changeover switch (for 3RT1...-N)
- 8) Solid-state module with remaining lifetime indicator (auxiliary switch block not mountable on right-hand side)

Controls – Contactors and Contactor Assemblies

Project planning aids

3RT10 and 3RT14 contactors, 3-pole

3RT10 6, 3RT14 6 contactors, size S10

with lateral and front mounted auxiliary switch block
 mounted overload relay and box terminals,
 lateral solid-state module with remaining lifetime indicator

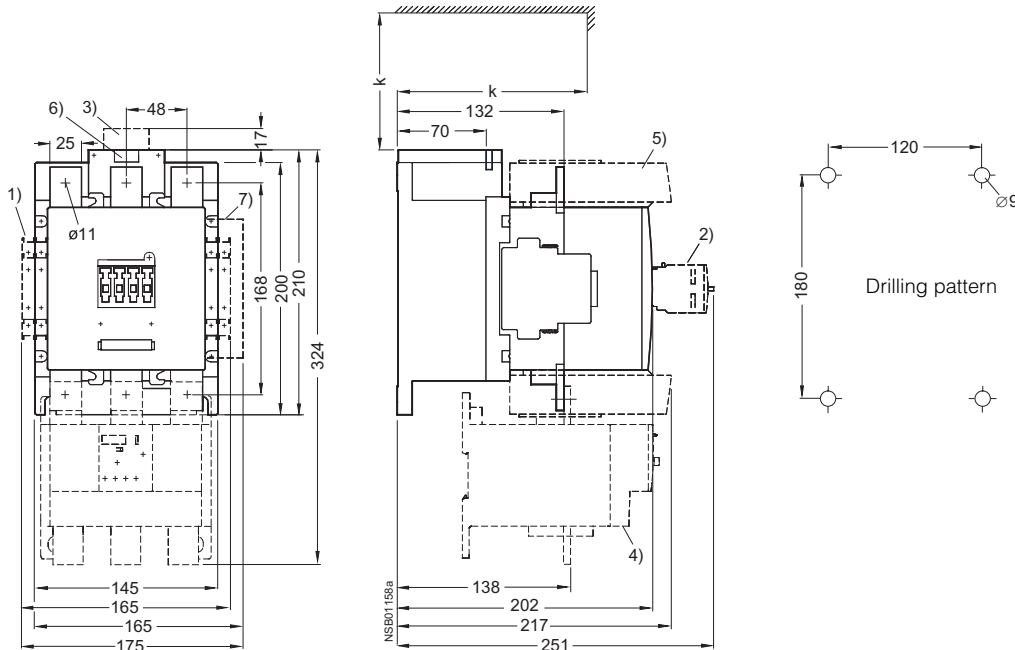

3RT10 7, 3RT14 7 contactors, size S12

with lateral and front mounted auxiliary switch block
 mounted overload relay and box terminals,
 lateral solid-state module with remaining lifetime indicator

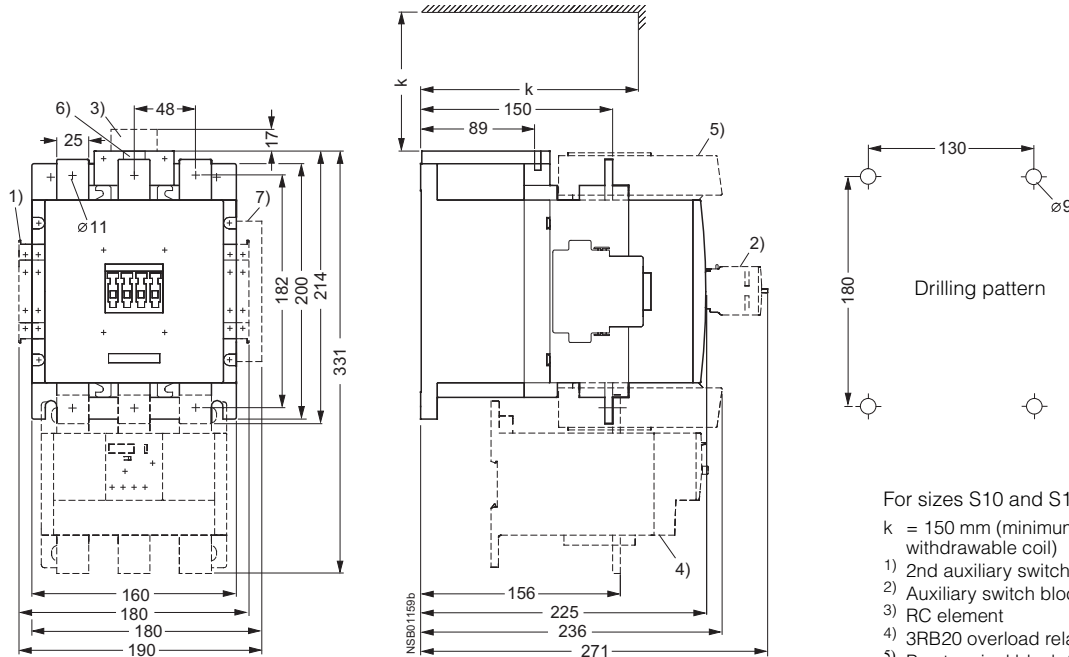

For sizes S10 and S12:
 Distance from grounded parts
 Lateral: 10 mm
 Front: 20 mm

- For sizes S10 and S12:
 k = 150 mm (minimum clearance for removing the withdrawable coil)
- 1) 2nd auxiliary switch block, lateral
 - 2) Auxiliary switch block, mountable on the front
 - 3) RC element
 - 4) 3RB20 overload relay, mounted
 - 5) Box terminal block (Allen screw 6 mm)
 - 6) PLC connection 24 V DC and changeover switch (for 3RT1...-N)
 - 7) Solid-state module with remaining lifetime indicator (auxiliary switch block not mountable on right-hand side)

3

3RT12 vacuum contactors, 3-pole

3RT12 6 vacuum contactors, size S10

with lateral auxiliary switch block,
mounted overload relay and box terminals

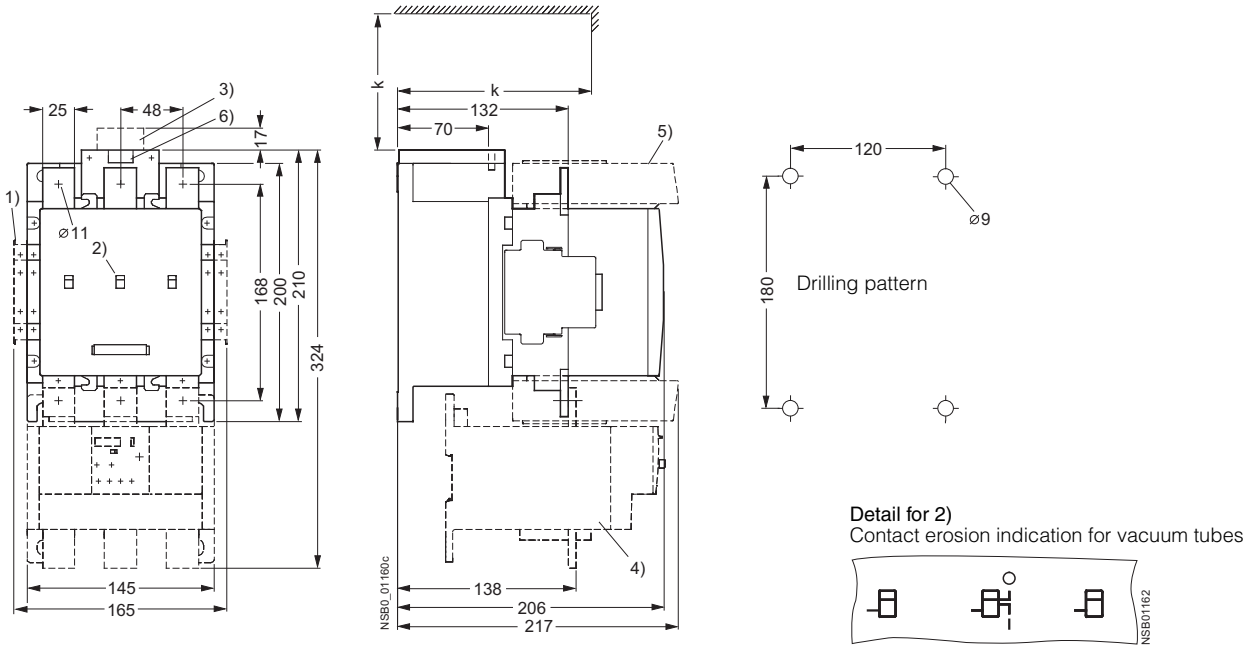

3RT12 7 vacuum contactors, size S12

with lateral auxiliary switch block,
mounted overload relay and box terminals

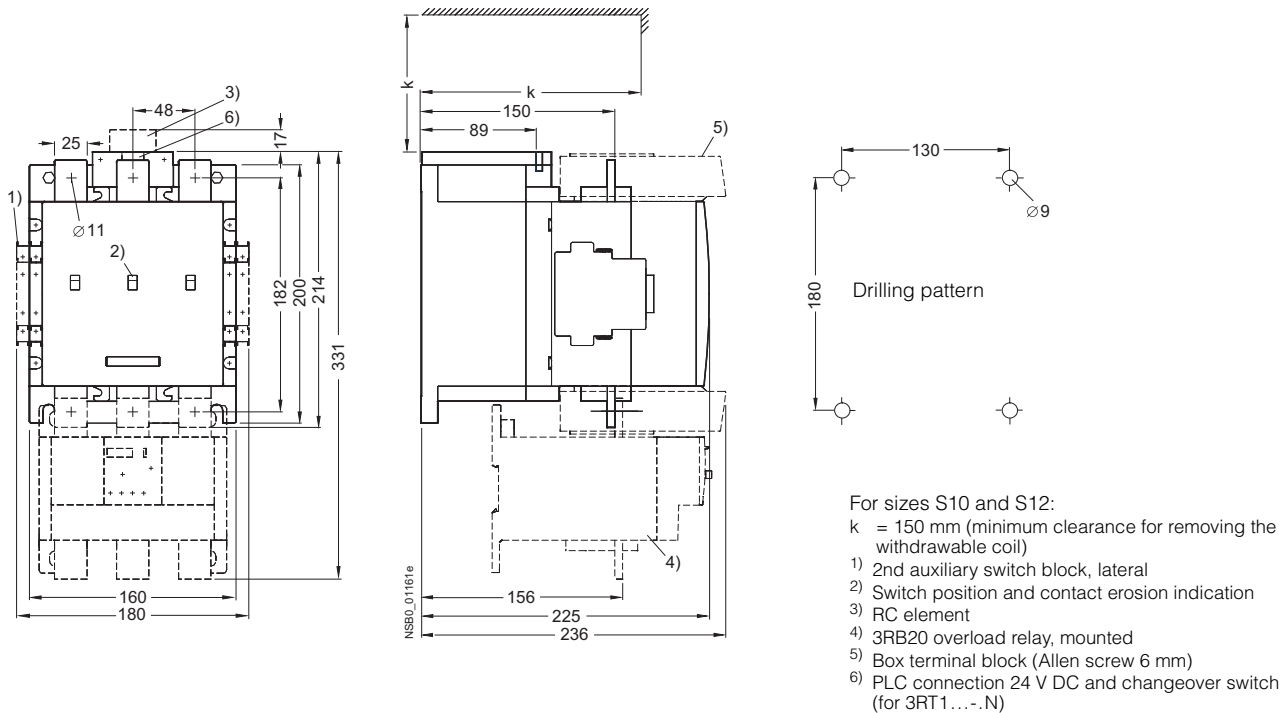

Project planning aids

3RT13 and 3RT15 contactors, 4-pole

3RT13 1 and 3RT15 1 contactors, size S00,

Screw terminals
with surge suppressor and auxiliary switch block

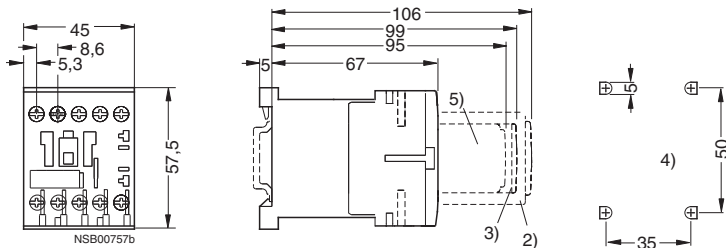

Lateral distance to
grounded components = 6 mm

For size S00:

Deviating dimensions for contactors
with Cage Clamp terminals:
Height: 60 mm
Mounting depth with auxiliary switch block:
110 mm

- 2) Auxiliary switch block
(also solid-state compatible version
3RH19 11-.N...)
- 3) Surge suppressor
(also 3RT19 16-1GA00
additional load module)
- 4) Drilling pattern
- 5) Auxiliary switch block
1-pole

3RT13 2 and 3RT15 2 contactors, size S0

with surge suppressor and auxiliary switch block

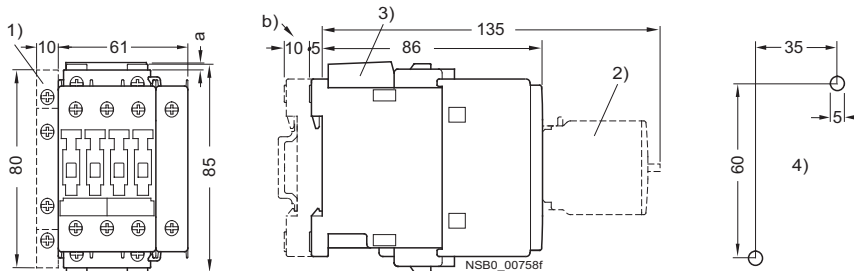

For size S0:

a = 3 mm at < 250 V and mounting of
surge suppressor
a = 7 mm at > 250 V and mounting of
surge suppressor

- b = DC 10 mm deeper than AC
- 1) Auxiliary switch block, laterally mountable
(left)
 - 2) Auxiliary switch block, mountable on the
front
 - 3) Surge suppressor
 - 4) Drilling pattern

3RT13 3 and 3RT15 3 contactors, size S2

with surge suppressor and auxiliary switch block

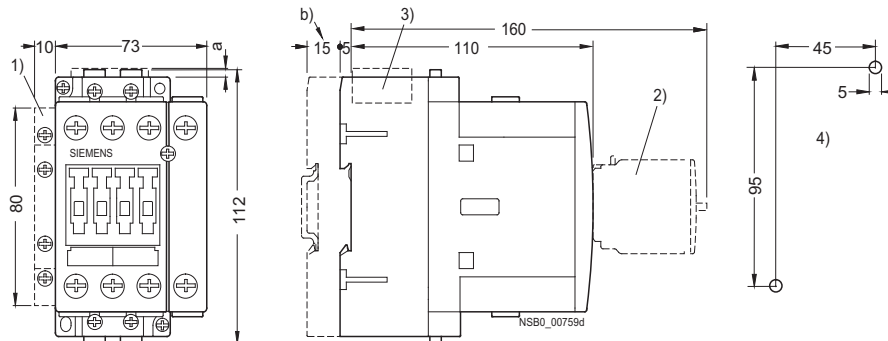

For sizes S2 and S3:

a = 0 mm with varistor < 240 V
a = 3.5 mm with varistor > 240 V
a = 17 mm with RC element and diode
assembly

- b = S2: DC 15 mm deeper than AC
S3: DC 13 mm deeper than AC
- 1) Auxiliary switch block, laterally mountable
(right or left)
 - 2) Auxiliary switch block, mountable on the
front, (1-, 2- and 4-pole, also 3RH19 21-
1FE22 solid-state compatible version)
 - 3) Surge suppressor
 - 4) Drilling pattern
 - 5) For mounting onto TH 35 standard mount-
ing rail according to EN 60715 (15 mm
deep) or for size S3 also to TH 75 standard
mounting rail according to EN 60715
 - 6) Allen screw 4 mm

3RT13 4 contactors, size S3

with surge suppressor and auxiliary switch block

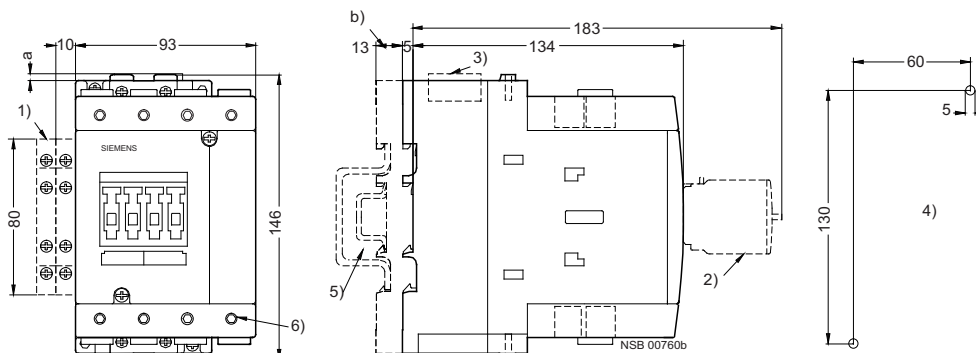

3RT16 capacitor contactors

3RT16 17 capacitor contactors, size S00

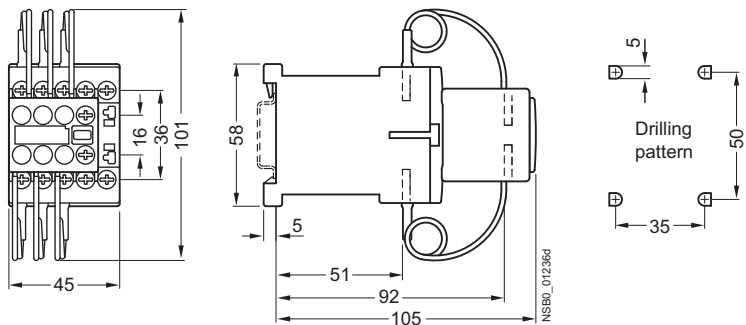

3RT16 27 capacitor contactors, size S0

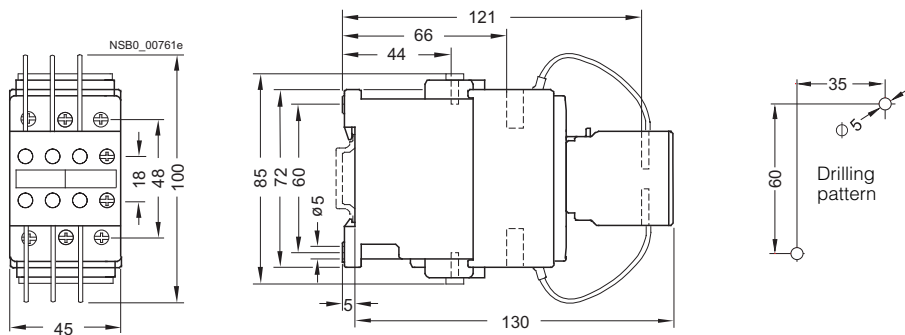

3RT16 47 capacitor contactors, size S3

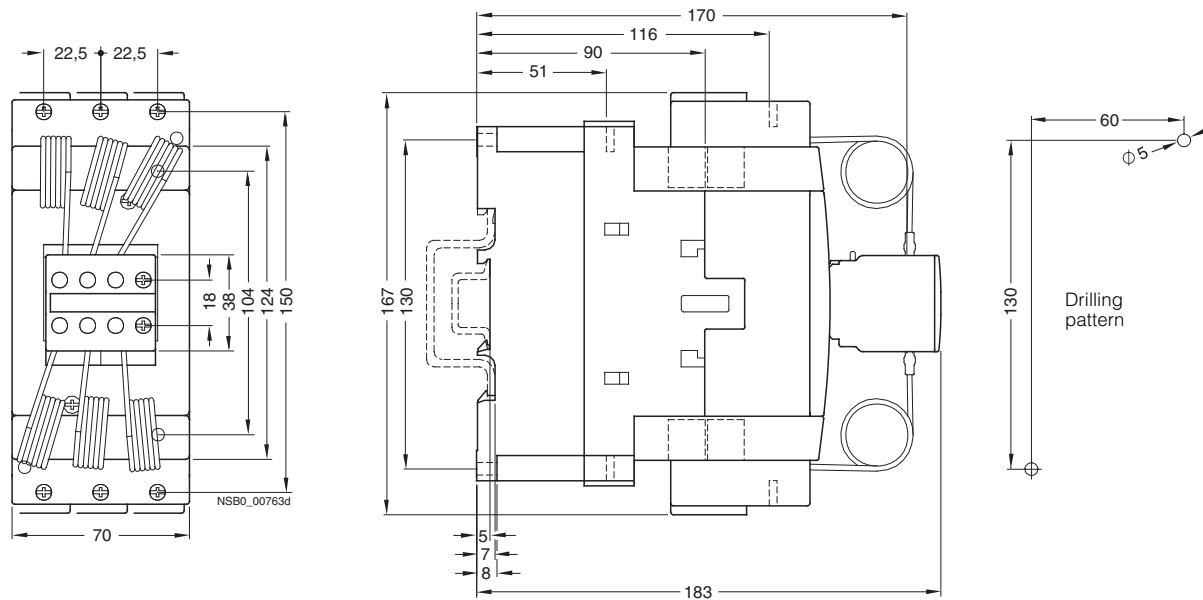

Controls – Contactors and Contactor Assemblies

Project planning aids

Contactors with extended operating range 0.7 to $1.25 \times U_s$

Size S00

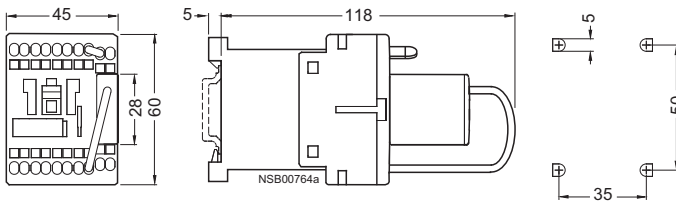

Without series resistor:

3RH11 22-2KB40

-2KF40

3RT10 17-2KB41

-2KF41

-2KB42

-2KF42

For dimensions see page 3/179 (size S00)

Size S0¹⁾

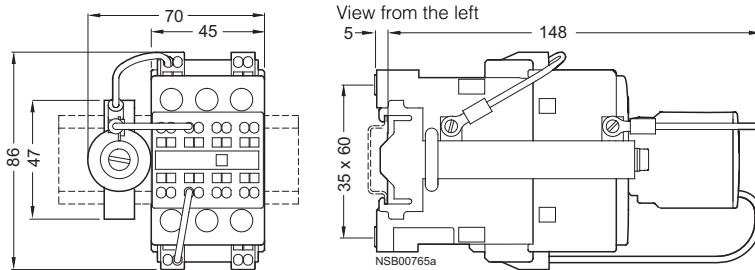

Without series resistor:

3RT10 25-3KB40

-3KF40

3RT10 26-3KB40

-3KF40

For dimensions see page 3/180 (size S0)

Size S2¹⁾

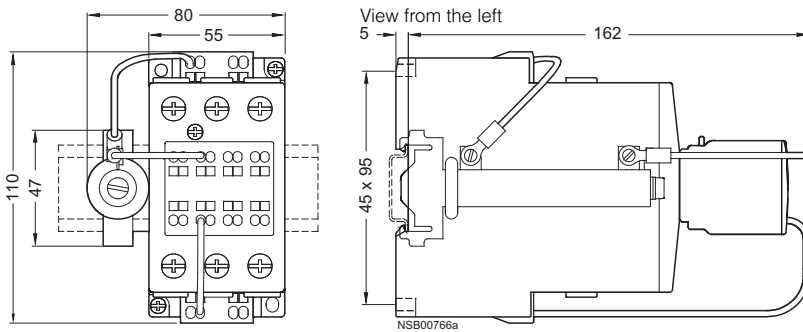

Size S3¹⁾

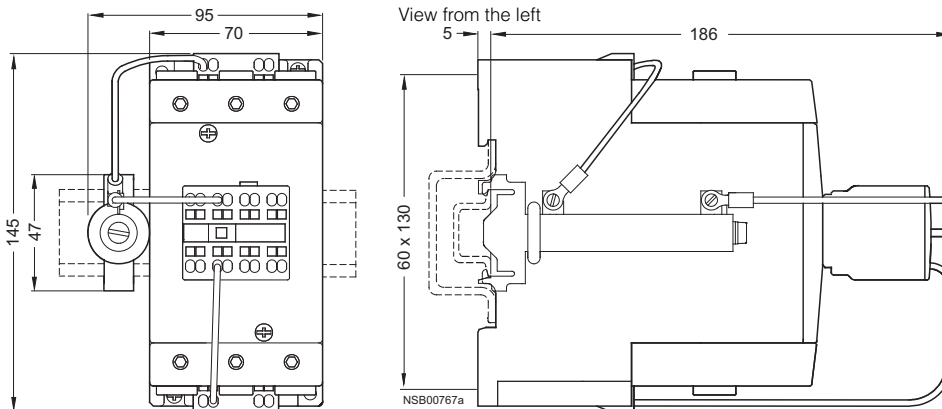

¹⁾ Sizes S0 to S3: Contactor series resistor must be connected by customer.
The series resistor is equipped with the necessary connecting cables.

Contactors with extended operating range 0.7 to 1.25 x U_s**3RT10 2 . -3X . 40-0LA2 contactors, size S0**

Cage Clamp terminals

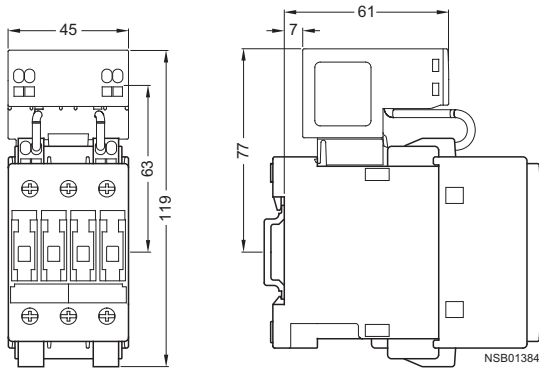
**3RT10 2 . -1X . 40-0LA2 contactors, size S0**

Screw terminals

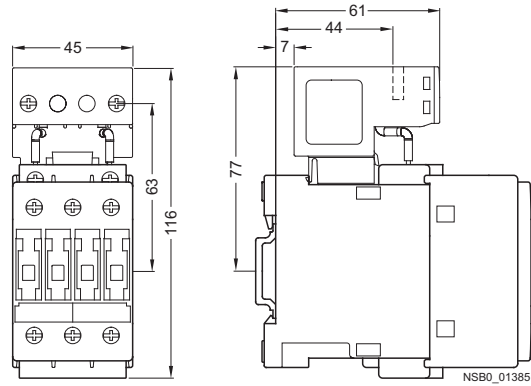
**3RT10 3 . -3X . 40-0LA2 contactors, size S2**

Cage Clamp terminals

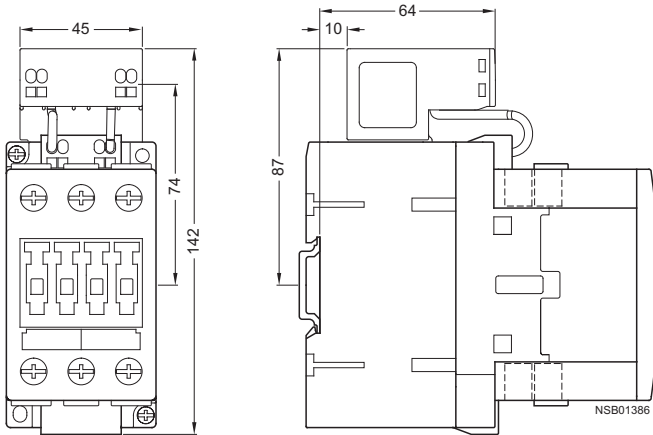
**3RT10 3 . -1X . 40-0LA2 contactors, size S2**

Screw terminals

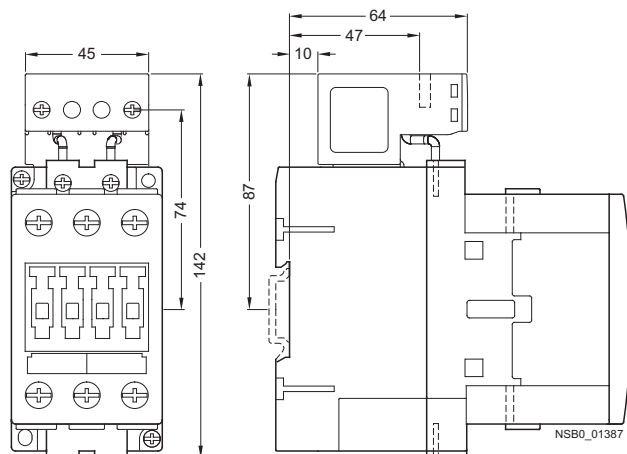

All dimensions not mentioned are identical to those of the contactors with DC operation (see page 3/180 to page 3/182).

Project planning aids

*Contactors with extended operating range 0.7 to 1.25 x U_s***3RT10 4.-3X.40-0LA2 contactors, size S3**

Cage Clamp terminals

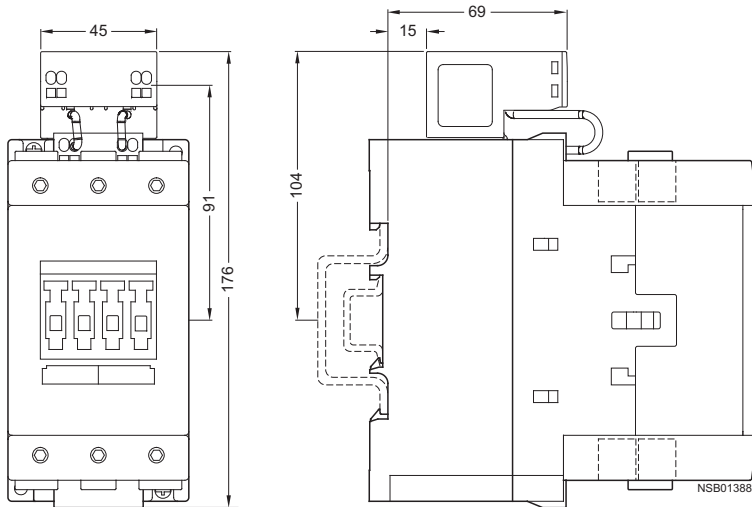
**3RT10 4.-1X.40-0LA2 contactors, size S3**

Screw terminals

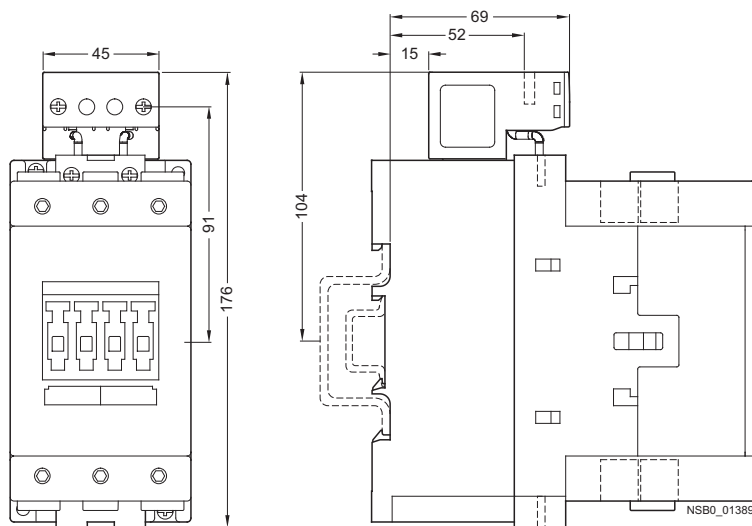

All dimensions not mentioned are identical to those of the contactors with DC operation (see page 3/180 to 3/182).

3RH11 and 3RH14 contactor relays

3RH11 contactor relays, size S00

with screw terminals,
with surge suppressor and auxiliary switch block

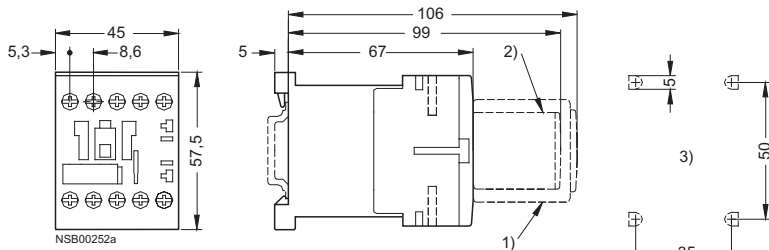

Lateral distance to grounded components = 6 mm

- 1) Auxiliary switch block
- 2) Surge suppressor
- 3) Drilling pattern

with Cage Clamp terminals,
with auxiliary switch block

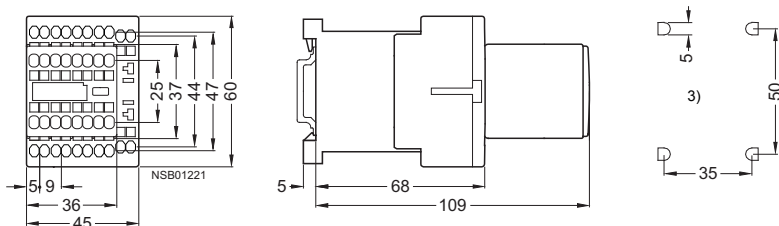

3RH14 latched contactor relays, size S00

with surge suppressor and auxiliary switch block

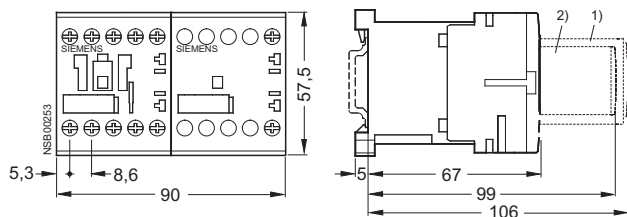

3RH11 coupling relays

3RH11 coupling relays, size S00

with screw terminals,
with surge suppressor

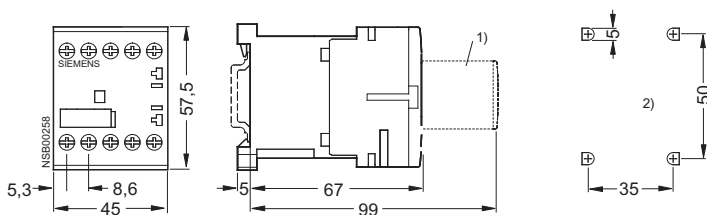

- 1) Surge suppressor
- 2) Drilling pattern

Deviating dimensions for coupling relays
with Cage Clamp terminals:
Height: 60 mm

Project planning aids

3TH42/3TH43

AC operation

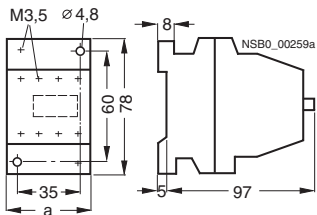

Contactor a type	
3TH42	45
3TH43	55

DC operation

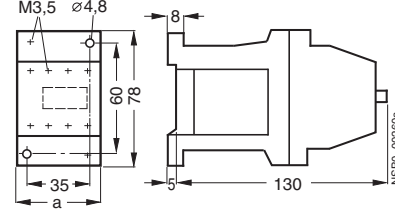

Contactor a type	
3TH42	45
3TH43	55

Accessories for 3TH42/3TH43 contactor relays

**3TX7 402-3 varistors,
3TX7 402-3A noise suppression diode,
3TX7 402-3D diode assemblies**

(for DC operation) for 3TH42/3TH43 contactor relays for mounting onto the coil terminals

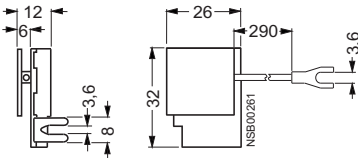

3TX7 402-3 RC elements

for 3TH42/3TH43 contactor relays for mounting onto the coil terminals

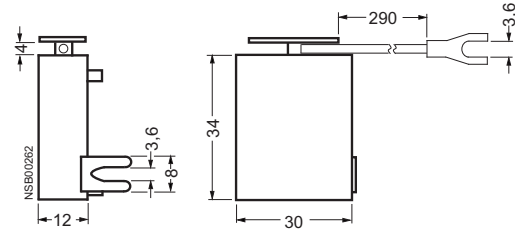

3TX4 180-0A ON-delay devices

for 3TH42/3TH43 contactor relays

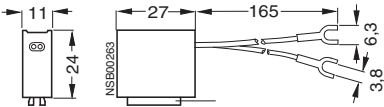

3TX4 701 OFF-delay devices

for 3TH42/3TH43 contactor relays

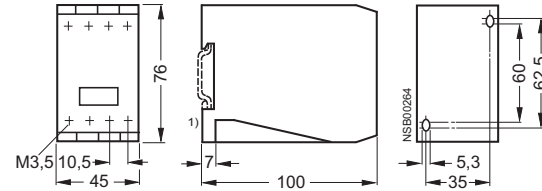

3TX4 090-0C coupling link

for mounting onto the contactor coil of 3TH42/3TH43 contactor relays, without surge suppression

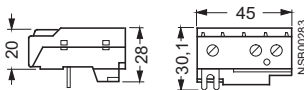

3TX4 090-0D coupling link

for mounting onto the contactor coil of 3TH42/3TH43 contactor relays with surge suppression

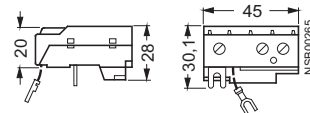

1) For 35 mm standard mounting rail.

Accessories for 3RT1 contactors

3RT19 16-2E . . . , 3RT19 16-2F . . . , 3RT19 16-2G . . .
solid-state time-delay auxiliary switch blocks
for contactors, size S00

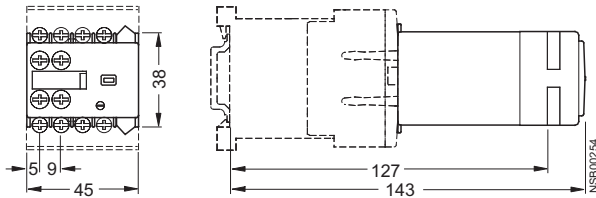

3RT19 26-2E . . . , 3RT19 26-2F . . . , 3RT19 26-2G . . .
solid-state time-delay auxiliary switch blocks
for contactors, sizes S0 to S3

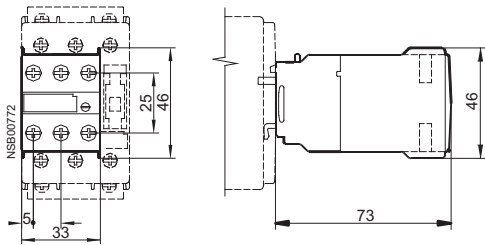

3RT19 16-2B.01
OFF-delay devices
for contactors, sizes S00 to S3

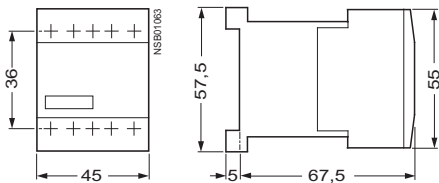

3RT19 16-4KA1
solder pin adapters
Size S00
Mounted onto 3RT10 1. contactors with 1 auxiliary contact
in the basic unit

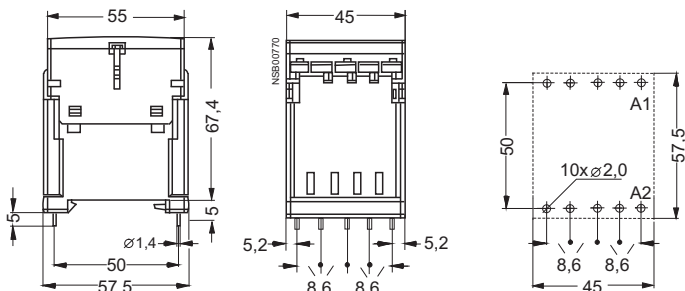

3RT19 16-2
solid-state time-delay blocks, with ON-delay
Size S00
for mounting onto the front of contactors
(the dimensions are also valid for time-delay blocks with an
OFF-delay)

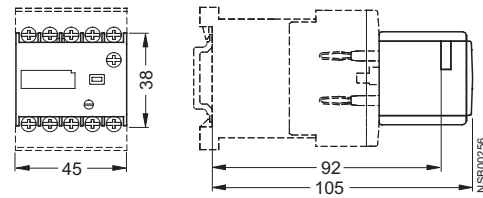

3RT19 26-2
solid-state time-delay blocks, with ON-delay
Sizes S0 to S3
for mounting onto the top of the contactors
(the dimensions are also valid for time-delay blocks with an
OFF-delay and for 3RH19 24-1GP11 coupling links)

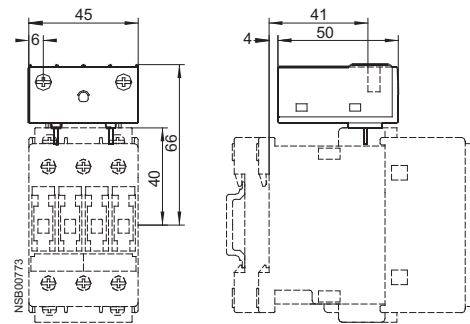

3RT19 26-2P.1
pneumatic delay block
for contactors, size S0
for mounting onto the front of 3RT1. 2 contactors

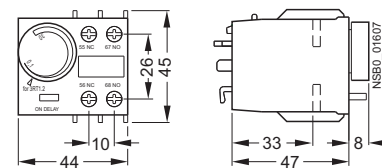

3RT19 26-4P
screw adapters
for contactors of size S0

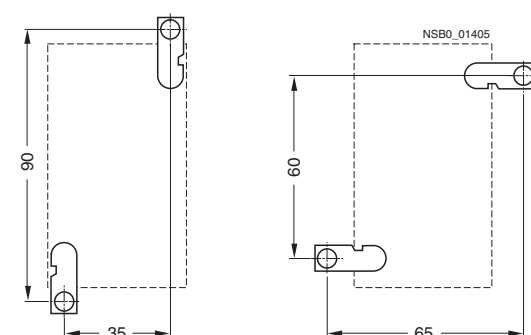

Project planning aids

Accessories for 3RT1 contactors

3RT19 16-4BB31
parallel connector
Size S00
3-pole, with terminal

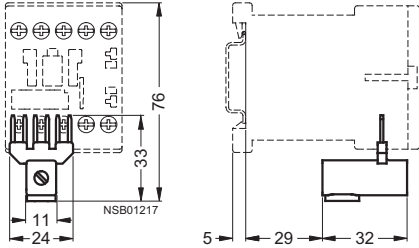

3RT19 16-4BB41
parallel connector
Size S00
4-pole, with terminal

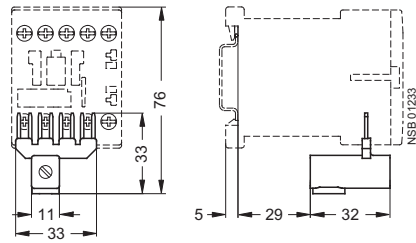

3RT19 26-4BB31
parallel connector
Size S0
3-pole, with terminal

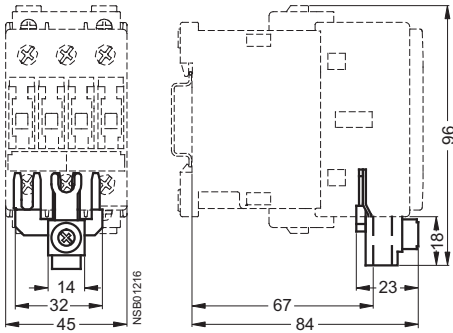

3RT19 36-4BB31
parallel connector
Size S2
3-pole, with terminal

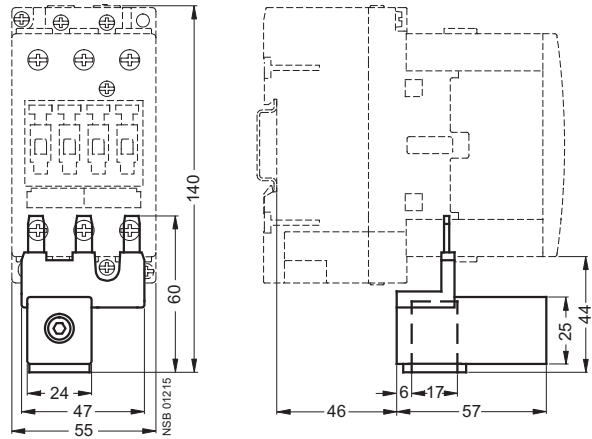

3RT19 46-4BB31
parallel connector
Size S3
3-pole, with through hole and cover for touch protection

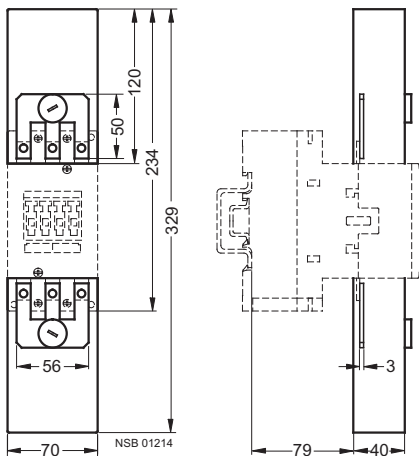

3RT19 26-3A.
mechanical latching block

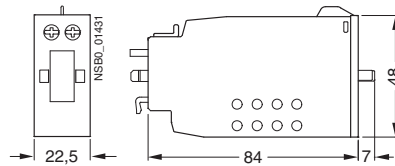

Accessories for 3RT1 contactors

3RT19 36-4EA2

terminal cover for box terminals
for size S2

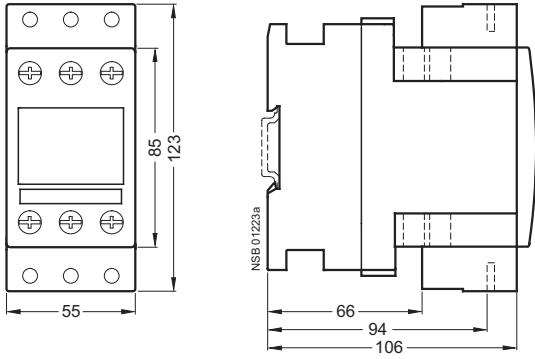

3RT19 46-4EA2

terminal cover for box terminals
for size S3

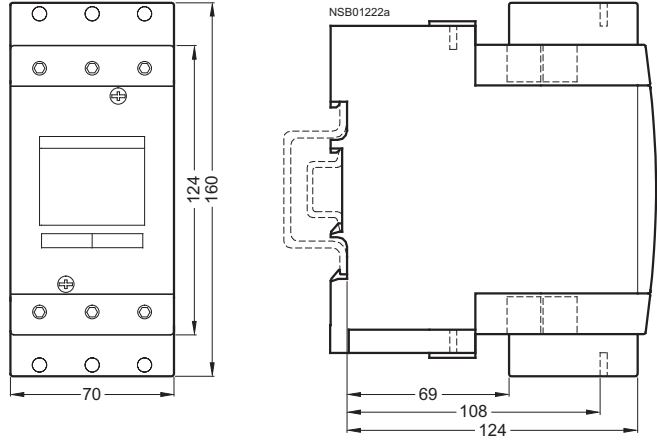

3RT19 46-4EA1

terminal cover for cable lug and busbar connection
for size S3

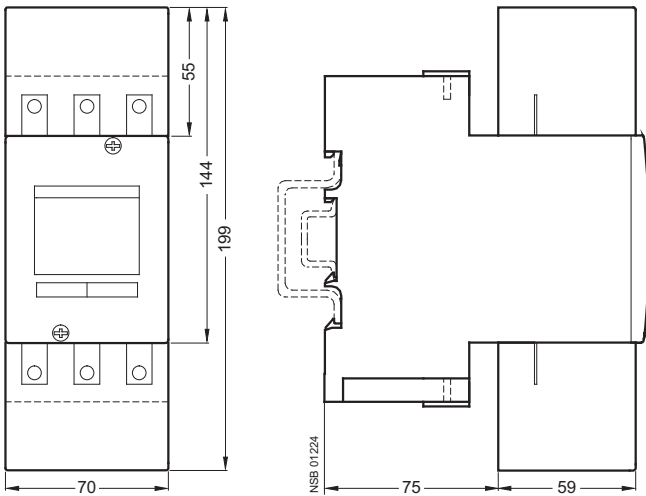

Project planning aids

Accessories for 3RT1 contactors

3RT19 46-4F

auxiliary terminals, 3-pole

Size S3

Mounted on contactor

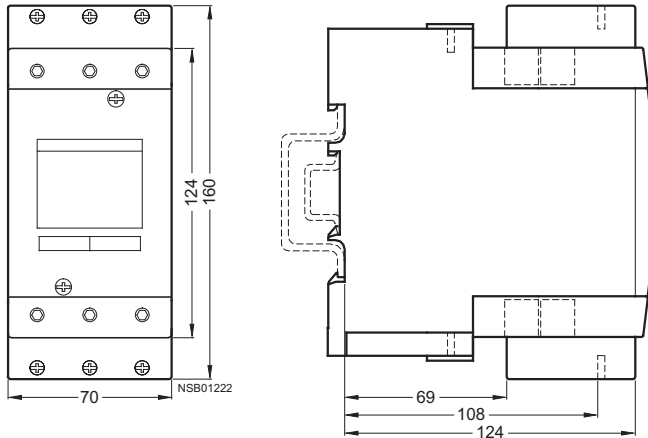
**3RH19 11-1AA... 3RH19 11-1LA...**

auxiliary switch blocks

for size S00

Screw terminals

2-pole

Cable entry from above

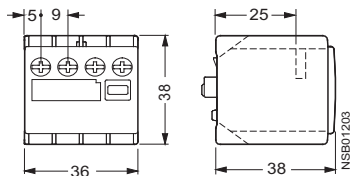
**3RH19 11-1BA... 3RH19 11-1MA...**

auxiliary switch blocks

for size S00

Screw terminals

2-pole

Cable entry from below

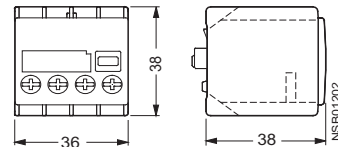
**3RH19 11-1F... 3RH19 11-1H...**

auxiliary switch blocks according to EN 50012 and EN 50005

for size S00

Screw terminals

1- to 4-pole

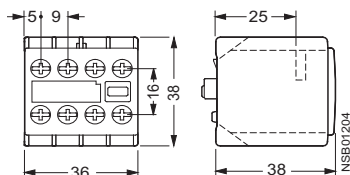
**3RH19 11-. NF...**

solid-state compatible auxiliary switch blocks according to EN 50005

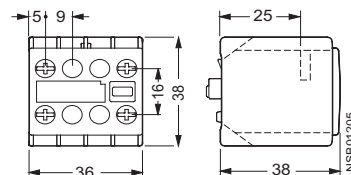
for size S00Screw terminals ¹⁾**3RH19 11-2F... 3RH19 11-2H...**

auxiliary switch blocks according to EN 50005 and EN 50012

for size S00

Cage Clamp terminals

1- to 4-pole

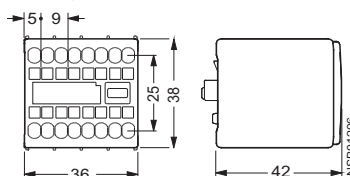
**3RH19 11-1AA... 3RH19 11-1BA...**

auxiliary switch blocks, 1-pole

for size S00

Cable entry from one side

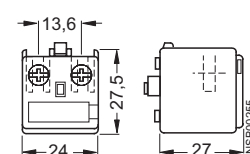

¹⁾ Deviating dimension for auxiliary switch block with Cage Clamp terminals: mounting depth 42 mm.

Accessories for 3RT1 contactors

3RH19 21- HA ... 3RH19 21- F ...
 auxiliary switch blocks according to EN 50005 and EN 50012
for sizes S0 to S12

Screw and Cage Clamp terminals
 4-pole

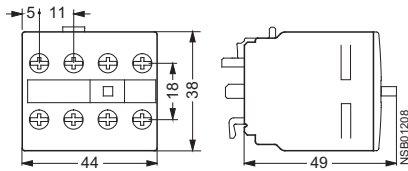

3RH19 21- C ...
 auxiliary switch block according to EN 50005 and EN 50012
for sizes S0 to S12

Screw and Cage Clamp terminals
 1-pole

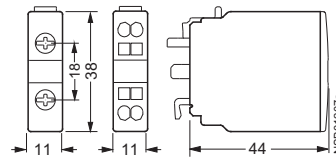

3RH19 21-1LA ...
 auxiliary switch block according to EN 50005
for sizes S0 to S12

Screw terminals
 2-pole
 Cable entry from above

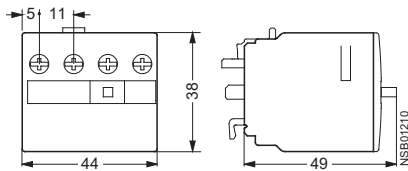

3RH19 21-1MA ...
 auxiliary switch block according to EN 50005
for sizes S0 to S12

Screw terminals
 2-pole
 Cable entry from below

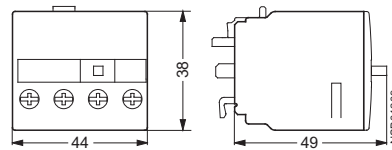

3RH19 21-1D ... 3RH19 21-1J ... 3RH19 21-1E ... 3RH19 21-1K ...
 auxiliary switch blocks, for lateral mounting
for sizes S0 to S12

Screw terminals
 2-pole

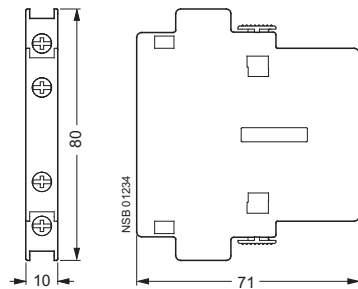

3RH19 21-2D ... 3RH19 21-2J ... 3RH19 21-2E ... 3RH19 21-2K ...
 auxiliary switch blocks, for lateral mounting
for sizes S0 to S12

Cage Clamp terminals
 2-pole

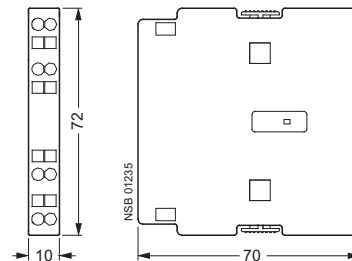

3RT19 00-4RE01 and 3RT19 16-4RD01
 connection modules for contactors with screw terminals
size S00

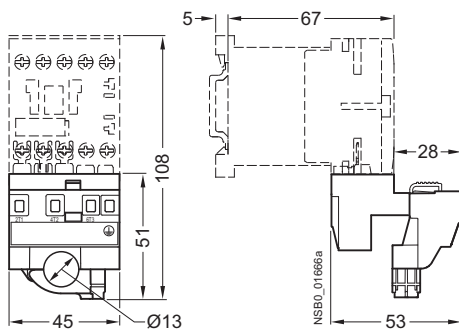

3RT19 00-4RE01 and 3RT19 26-4RD01
 connection modules for contactors with screw terminals
size S0

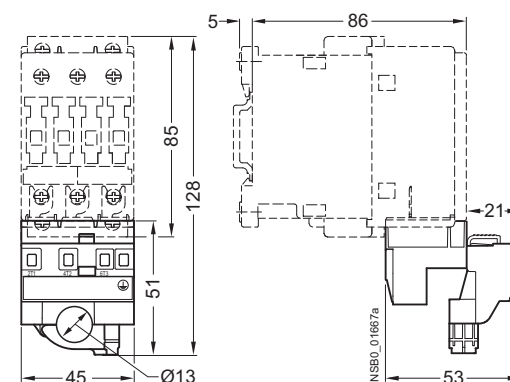

Project planning aids

Accessories for 3RT1 contactors

3RT19 66-1PV3

main current path surge suppression module
for 3RT12 vacuum contactors, sizes S10 and S12

Connected to outgoing side of contactor (2-T1/4-T2/6-T3)
using approx. 350 mm long, molded cable

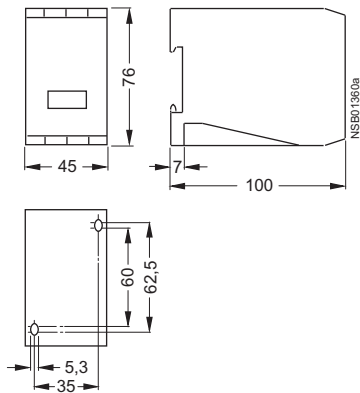

3RT19 .6-4EA1

terminal covers for busbar connections
Sizes S6 to S12

for mounting onto the contactor enclosure

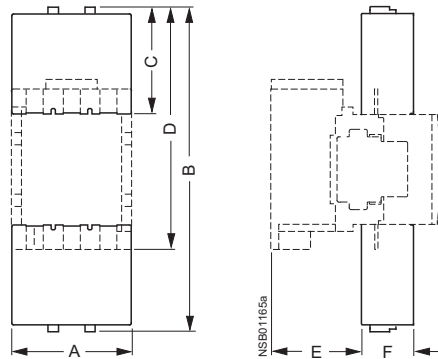

	A	B	C	D	E	F
S6	119	324	107	241	91	52
S10	145	385	128	289	106	66
S12	145	399	128	303	124	66

3RT19 66-1PV4

main current path surge suppression module
for 3RT12 vacuum contactors, sizes S10 and S12

Connected to outgoing side of contactor (2-T1/4-T2/6-T3)
using approx. 350 mm long, molded cable

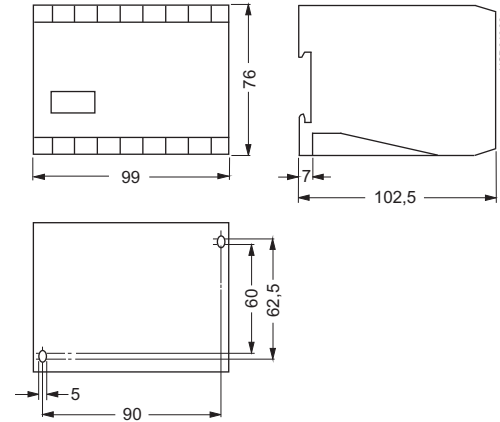

3RT19 .6-4EA2

terminal covers for box terminals
Sizes S6 to S12

for mounting onto box terminals

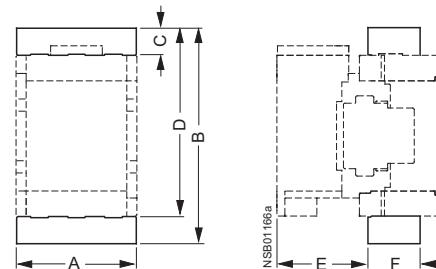

	A	B	C	D	E	F
S6	119	215	27	190	91	52
S10	145	265	30	235	106	66
S12	145	279	30	249	124	66

3RT19 .6-4BA31

links for paralleling
sizes S6 to S12

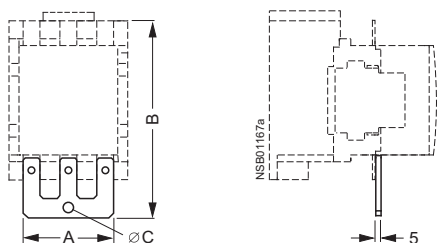

	A	B	∅C
S6	91	199	10.5
S10	121	244	12.5
S12	121	258	12.5

Accessories for 3RA1 contactor assemblies

3RA19 54-2A
mechanical interlocks
Sizes S6 to S12

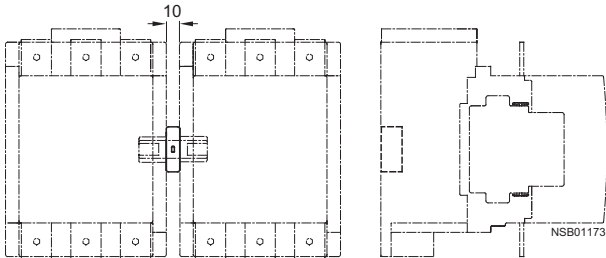

3RA19 .2-2A base plates for reversing contactor assemblies

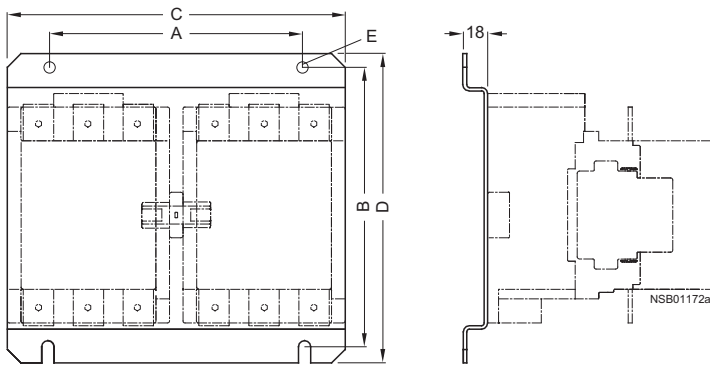

	A	B	C	D	E
S6	190	205	250	229	9
S10	240	249	300	275	11
S12	280	249	330	275	11

3RA19 .2-2E, 3RA19 .2-2F base plates for contactor assemblies for wye-delta starting

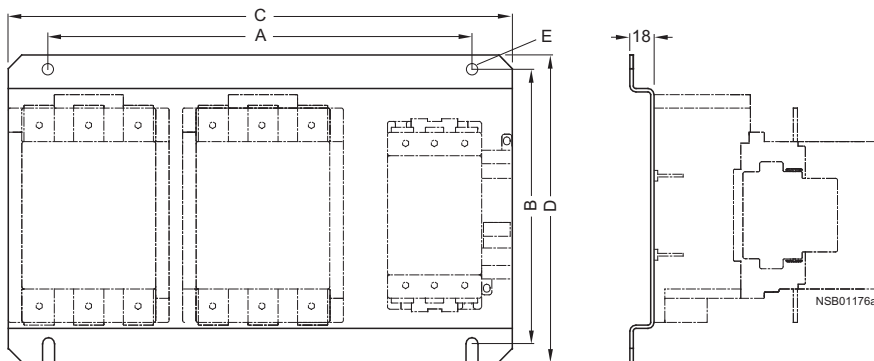

	A	B	C	D	E
S6-S6-S3	316	205	376	229	9
S6-S6-S6	343	205	403	229	9
S10-S10-S6	393	250	453	275	11
S10-S10-S10	423	250	483	275	11
S12-S12-S10	450	250	510	275	11
S12-S12-S12	465	250	525	275	11

Project planning aids

3RA13 reversing contactor assemblies

Size S00

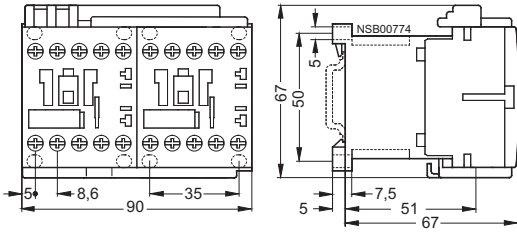

Size S0 with 3RA19 24-2B mechanical interlocking Lateral

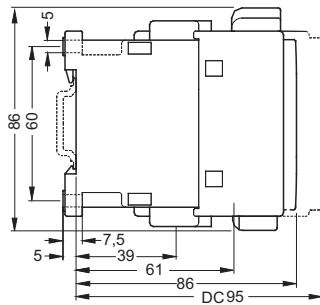
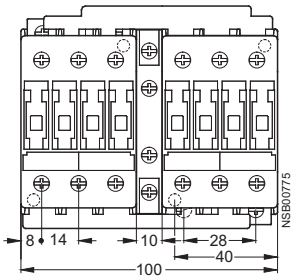

with 3RA19 24-1A mechanical interlocking On front

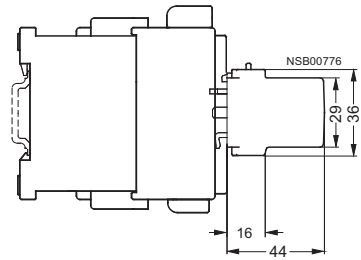
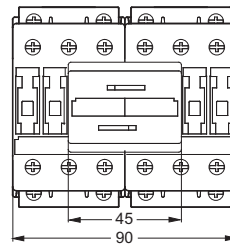

Size S2

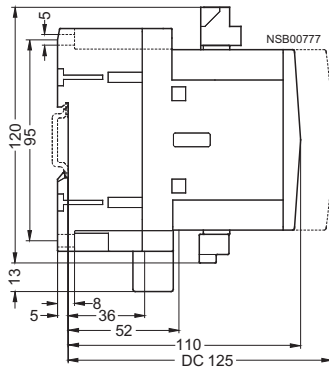
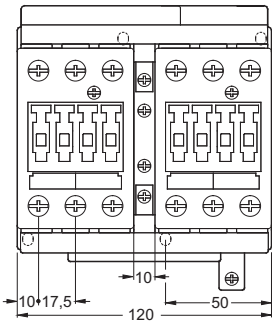

Size S3

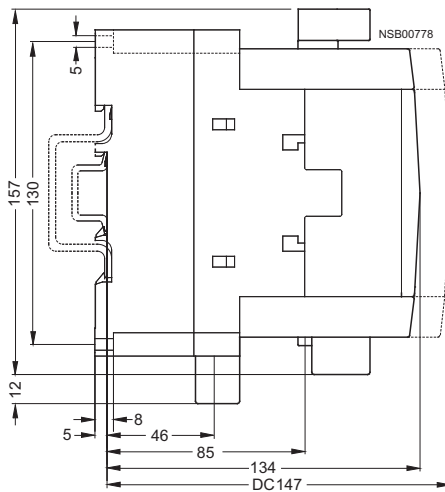
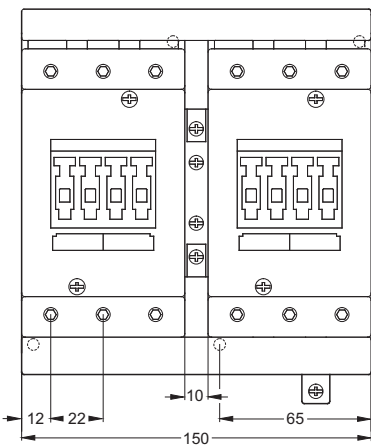

3RA13 reversing contactor assemblies

Size S6 with 3RA19 53-2A wiring module

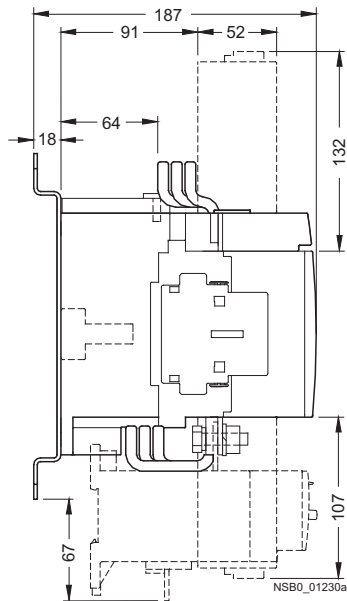
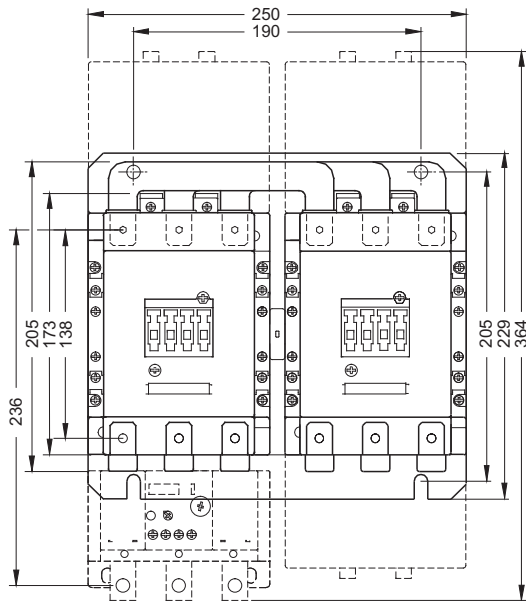

Size S6 with 3RA19 53-2M wiring module

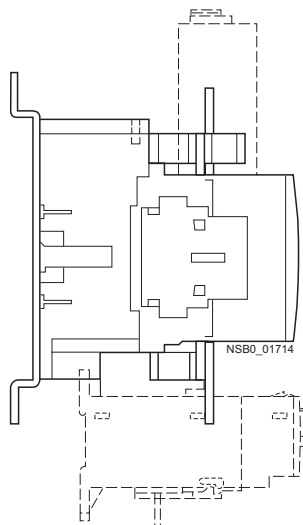
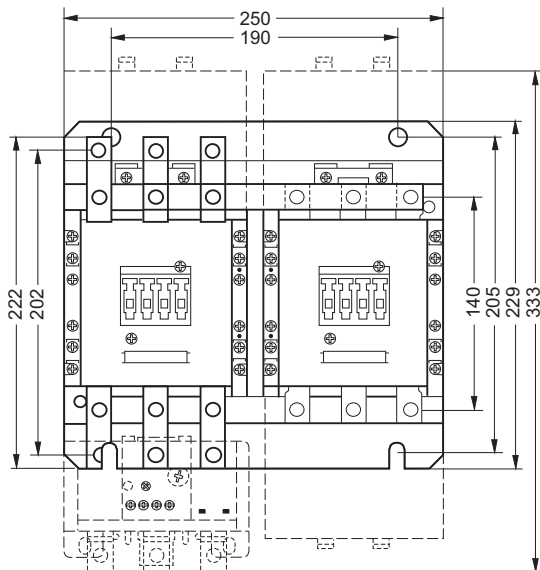

Project planning aids

3RA13 reversing contactor assemblies

Size S10

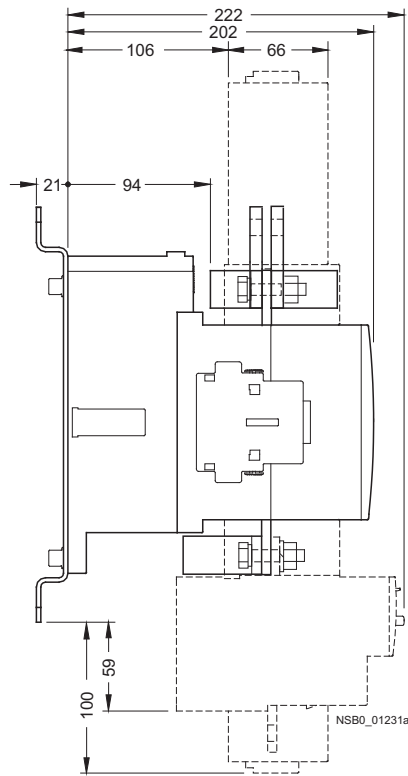
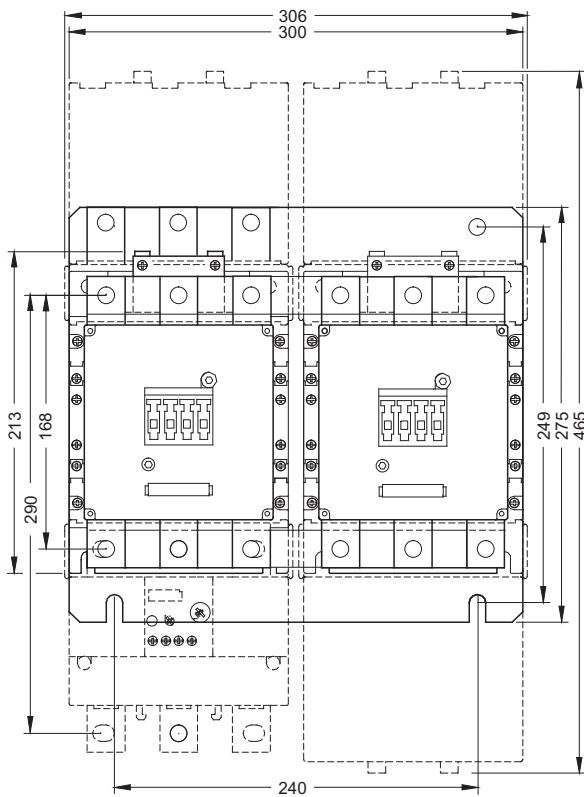

Size S12

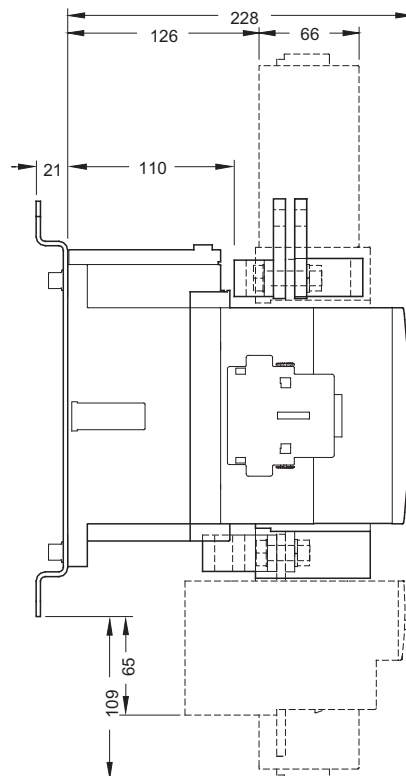
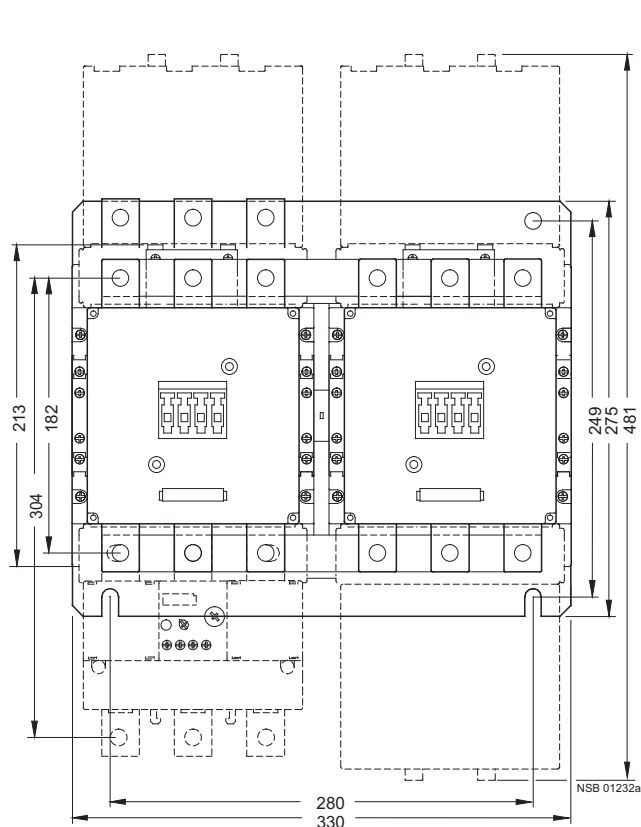

3RA14 contactor assemblies for wye-delta starting

Sizes S00 – S00 – S00

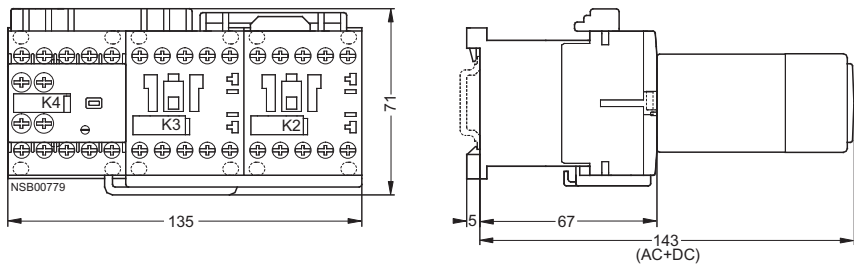

Sizes S0 – S0 – S0

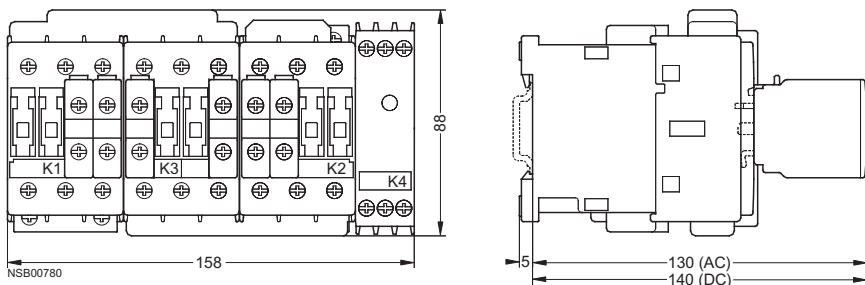

Sizes S2 – S2 – S0

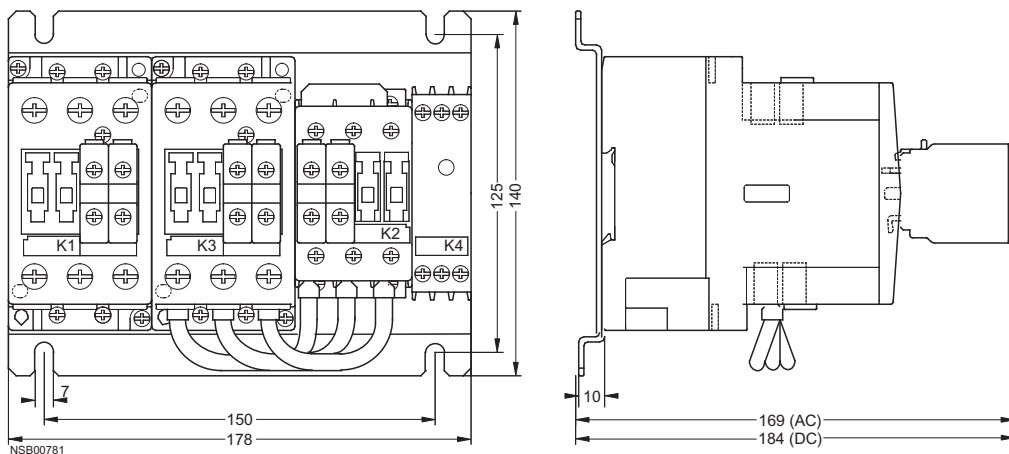

Sizes S2 – S2 – S2

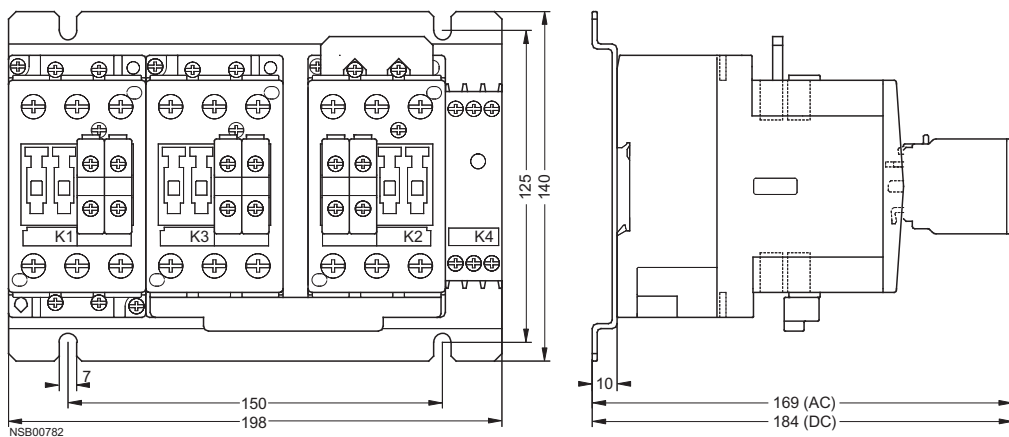

Project planning aids

3RA14 contactor assemblies for wye-delta starting

Sizes S3 – S3 – S2

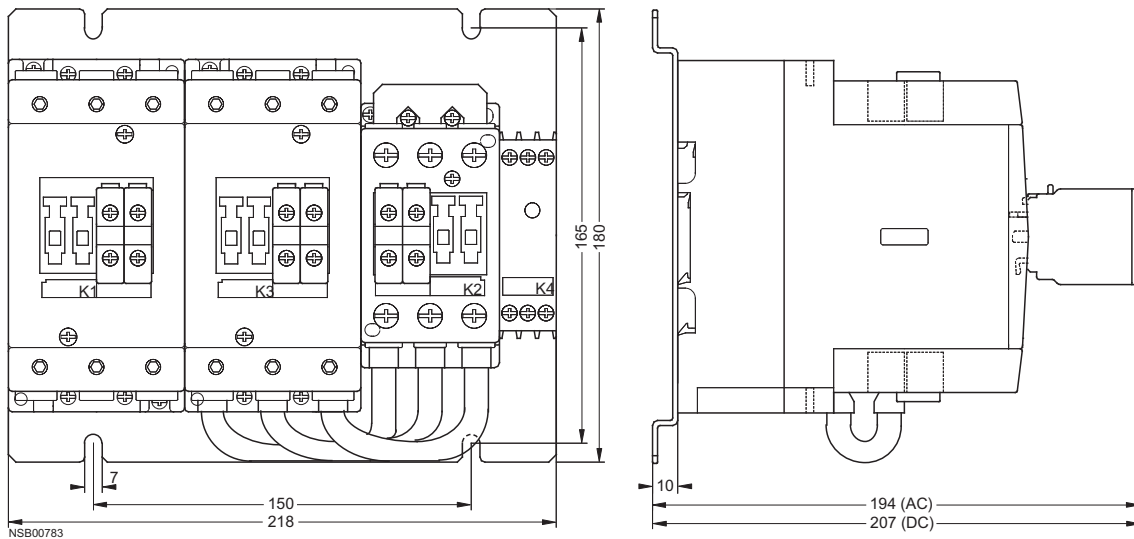

3TG10 miniature contactors

3TG10 ..-0..contactors
with screw terminals

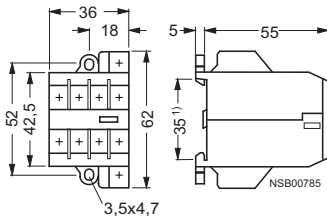

3TG10 ..-1..contactors
with tab connectors

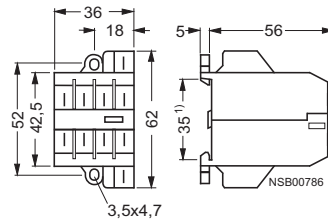

3TG10 contactors
with 3UA7 overload relays

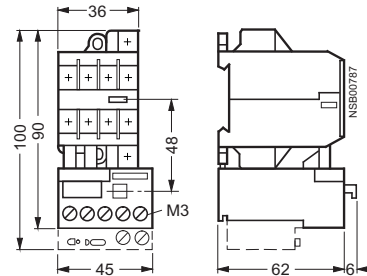

3RT19 16-4BB41 links for paralleling, 4-pole, with terminal
for **3TG10** contactors

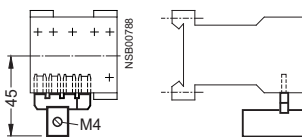

The links for paralleling can be reduced by one pole.

1) Can be snapped onto 35 mm standard mounting rail.

3TF68 and 3TF69 vacuum contactors, 3-pole

3TF68 vacuum contactors

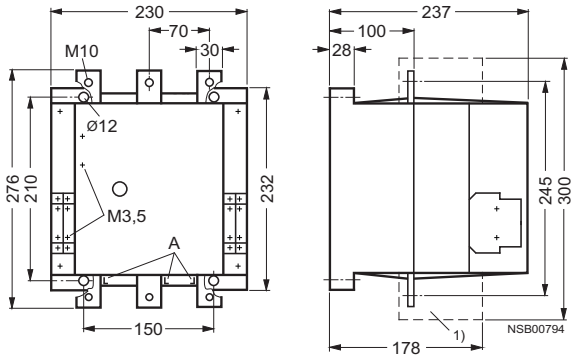

Detail

A = Contact erosion indication for vacuum interrupter contacts

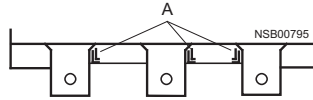

3TF69 vacuum contactors

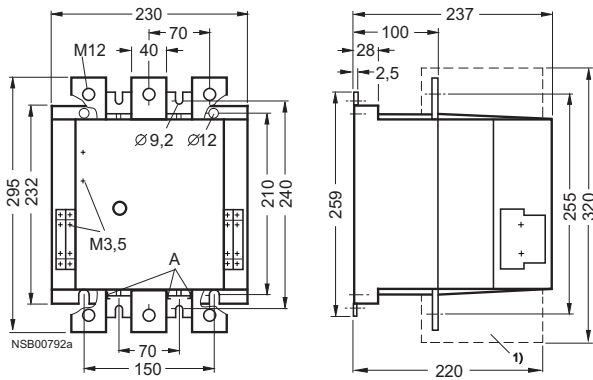

Detail

A = Contact erosion indication for vacuum interrupter contacts

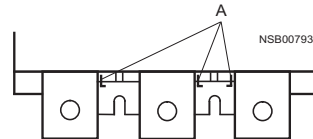

1) With box terminals for laminated copper bars (accessories).

Project planning aids

Accessories for 3T contactors

3TX7 462-3. varistors

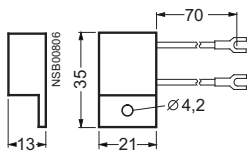

3TX7 462-3., 3TX7 522-3., 3TX7 572-3. RC elements and varistors

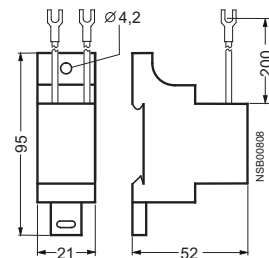

3TX7 090-0D coupling link for laterally snapping onto contactors

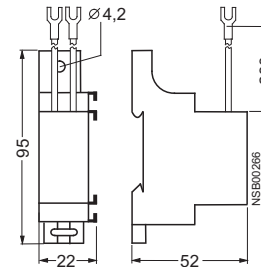

3TX7 box terminals for laminated copper bars

Box terminals with cover, mounted to contactor

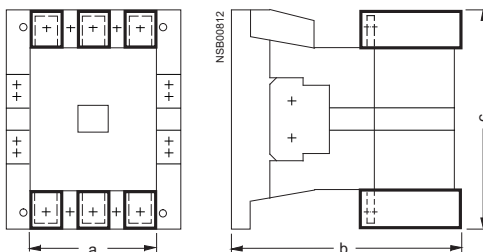

For contactor type	Box terminals	a	b	c
3TF68	3TX7 570-1.	182	178	300
3TF69	3TX7 690-1F	200	219	320

3TX7 686-0A and 3TX7 696-0A terminal covers

For 3TF68 and 3TF69 contactors, size 14,

for screwing onto free screw end of the two outer conducting paths

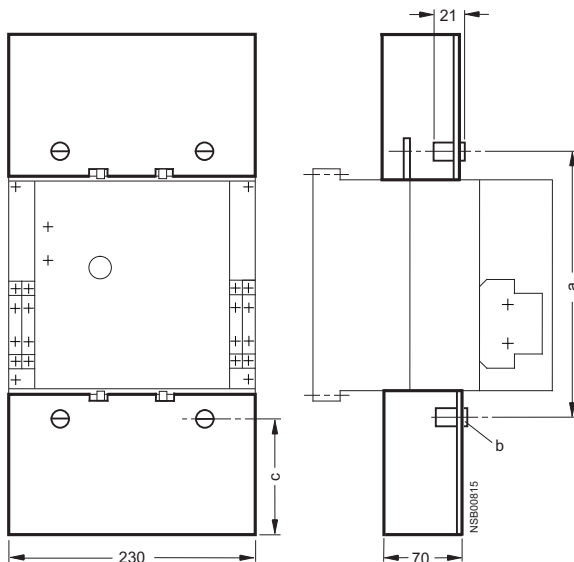

For contactor type	Terminal covers	a	b	c
3TF68	3TX7 686-0A	245	M10	104
3TF69	3TX7 696-0A	255	M12	99

3TX7 680-0D link for paralleling

for 3TF68 contactors

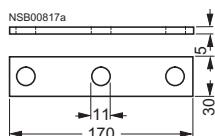

3TX7 680-0E cover plate

for 3TX7 680-0D link for paralleling for 3TF68 contactor

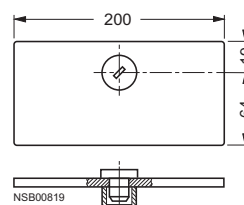

3TB5 contactors

3TB50 and 3TB52 contactors Sizes 6 and 8

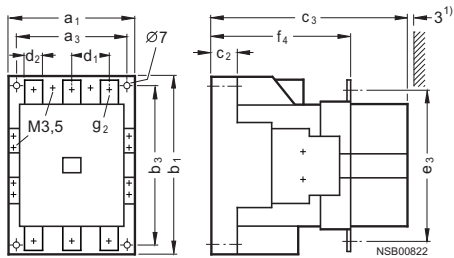

Type	a ₁	a ₃	b ₁	b ₃	c ₂	c ₃	d ₁	d ₂	e ₃	f ₄	g ₂
3TB50	120	100	150	130	23	198	37	15	133	137.5	M6
3TB52	135	110	180	160	28	217	42	20	154	147	M8

¹⁾ Minimum clearance from insulated components 3 mm.
Minimum clearance from grounded components 10 mm.

3TB54 and 3TB56 contactors Sizes 10 and 12

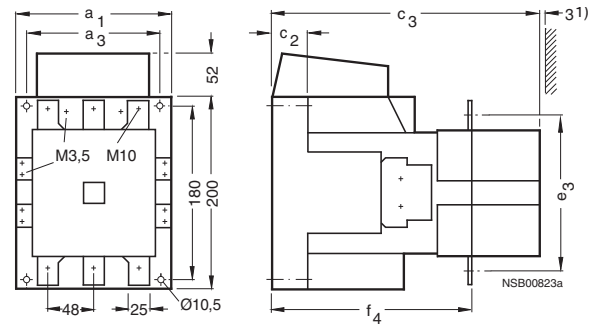

Type	a ₁	a ₃	c ₂	c ₃	e ₃	f ₄
3TB54	145	120	30.5	264	168	188
3TB56	160	130	39	282	178	200

3TX6 .. 6-3B terminal covers

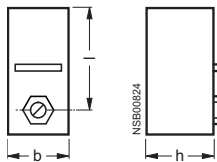

For contactors				
Size	Type	b	h	l
6	3TB50	27	33	58
8	3TB52	34	44	75
10 to 12	3TB54 to 3TB56	38	56	95

3TD68, 3TE68 contactor assemblies

3TD68 contactor assemblies

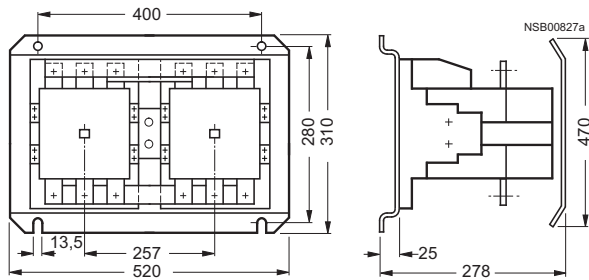

3TE68 contactor assemblies

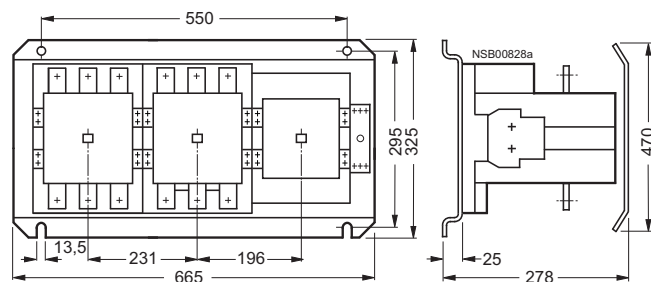

Controls – Contactors and Contactor Assemblies

Project planning aids

3TK10 to 3TK17 contactors

3TK10 to 3TK17 contactors

The scope of supply includes screws and rubber buffers.

⊕ M10 grounding screw for 3TK14 to 3TK17

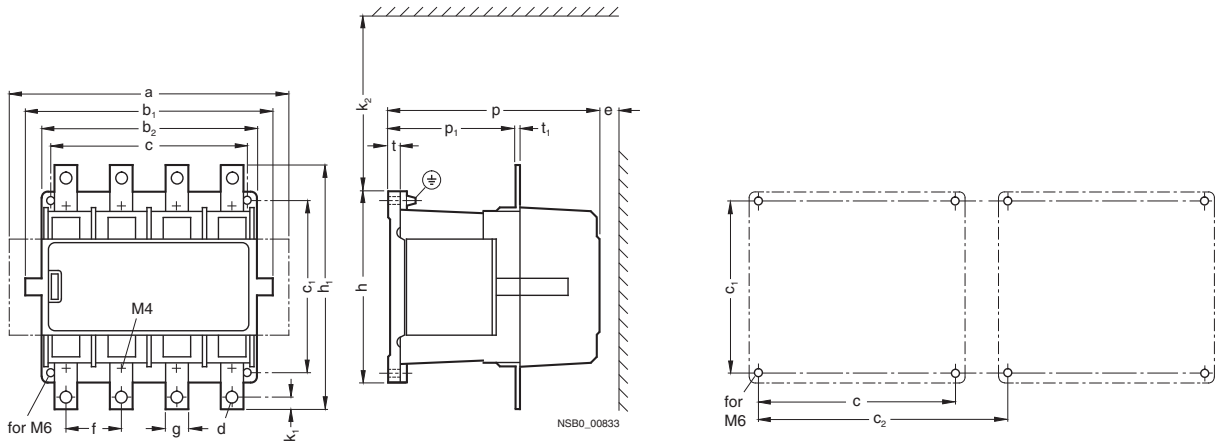

Contactors Type	a	b ₁	b ₂	c	c ₁	c ₂ ¹⁾	c ₂ ²⁾	d ³⁾	e min.	f	g	h	h ₁	k ₁	k ₂ ⁴⁾	p	p ₁	t	t ₁
3TK10	186	165	136	120	140	166	187	6.6	40	41	15	156	156	7.5	134	154.5	102.3	10	4
3TK11	186	165	136	120	140	168	187	11	40	42	20	156	172	10	134	154.5	102.3	10	4
3TK12	225	201	176	160	140	202	226	11	15	45	20	156	198	10	134	172	106.7	10	5
3TK13	225	201	176	160	140	202	226	11	15	45	20	156	198	10	134	172	106.7	10	5
3TK14	266	244	244	220	200	271	293	11	40	67	25	223	272	12.5	--	225.5	139.5	23 ⁵⁾	6
3TK15	266	244	244	220	200	271	293	11	40	67	25	223	273	12.5	--	225.5	139.5	23 ⁵⁾	6
3TK17	266	244	244	220	200	271	293	11	40	67	40	223	273	12.5	--	225.5	139.5	23 ⁵⁾	6

1) Distance when 2 contactors, each with one auxiliary switch block opposite, are mounted.

2) Distance when 2 contactors, each with two auxiliary switch blocks opposite, are mounted.

3) Nuts, bolts, screws and washers are supplied.

4) Minimum clearance for removing the withdrawable coil.

5) Damping elements are supplied.

Accessories for 3TK1 contactors

3TK19 4. terminal covers

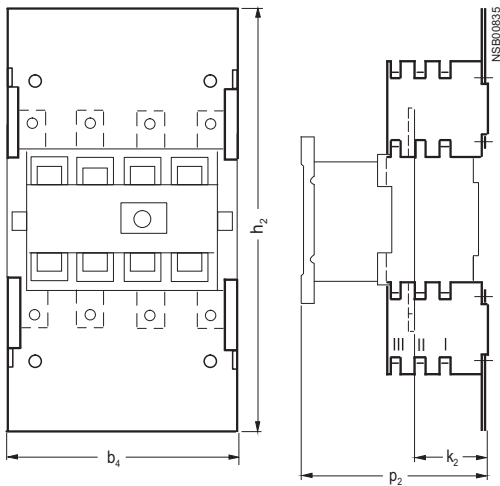

Contactors Type	Terminal covers	h_2	p_2 for			k_2 for			b_4
			I	II	III	I	II	III	
3TK10, 3TK11	3TK19 40-0A	372	153	178	203	47	72	97	168
3TK12, 3TK13	3TK19 42-0A	399	158	183	208	47	72	97	202
3TK14, 3TK15	3TK19 44-0A	464	193	218	243	47	72	97	268
3TK17	3TK19 46-0A	464	193	218	243	47	72	97	268

3TK19 20 and 3TK19 22 locking devices

for mechanical locking of two identical 3TK10 to 3TK13 contactors, mounted side by side on the mounting plate

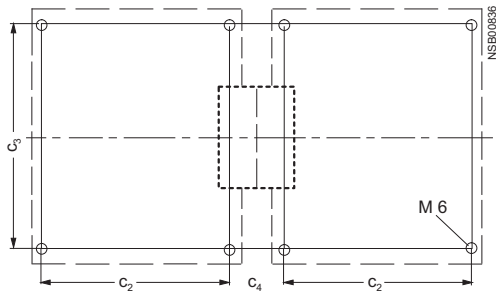

Contactors Type	Locking devices	c_2	c_3	c_4
3TK10, 3TK11	3TK19 20-0A	120	140	65
3TK12, 3TK13	3TK19 22-0A	160	140	63.5

3TK19 24 locking device

for mechanical locking of two identical 3TK14, 3TK15 or 3TK17 contactors, mounted side by side on the mounting plate

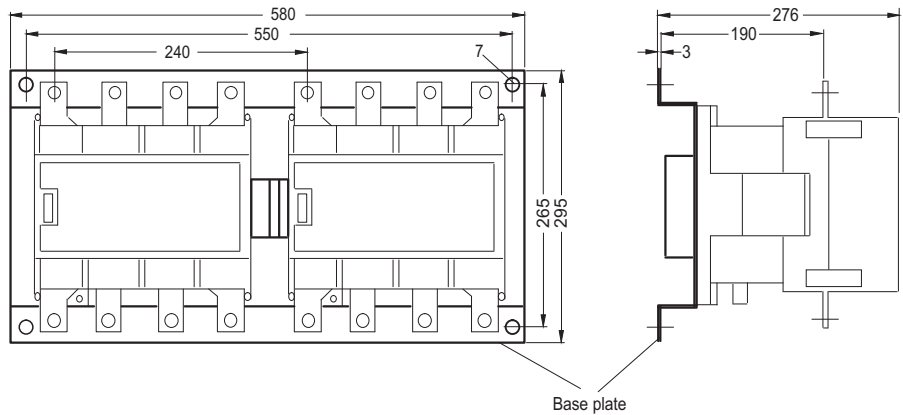

Project planning aids

3TC4 and TC5 contactors

3TC44 contactors Size 2, AC and DC operation

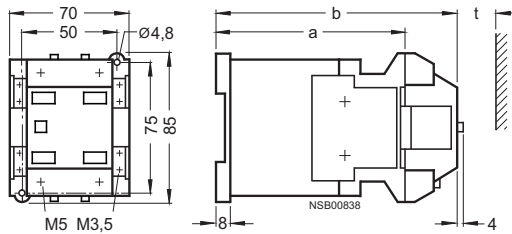

t = minimum clearance from insulated components: 15 mm (600 V and 750 V)
from grounded components: 30 mm (600 V and 750 V)

	a	b
DC operation	109	141
AC operation	68	100

3TC48 contactors Size 4, AC and DC operation

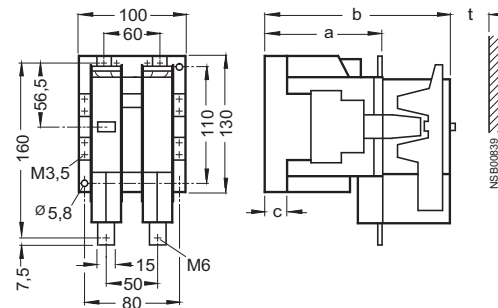

t = minimum clearance from insulated components: 15 mm (600 V),
20 mm (750 V)
from grounded components: 35 mm (600 V),
55 mm (750 V)

	a	b	c
DC operation	112	180	21,5
AC operation	86	154	23,5

3TC52 contactors Size 8, AC and DC operation

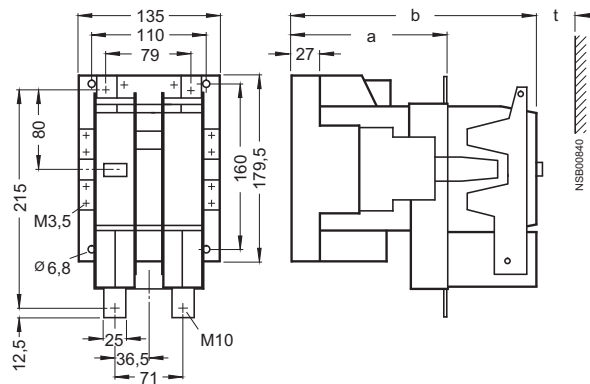

t = minimum clearance from insulated components: 20 mm (600 V and 750 V)
from grounded components: 70 mm (600 V and 750 V)

	a	b
DC operation	147	232
AC operation	115	200

3TC56 contactors Size 12, AC and DC operation

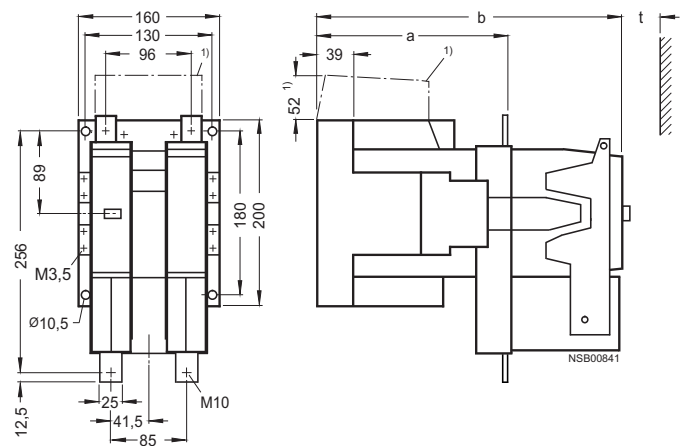

t = minimum clearance from insulated components: 25 mm (600 V and 750 V)
from grounded components: 80 mm (600 V),
100 mm (750 V)

	a	b
DC operation	200	310
AC operation	141	251

1) DC operation only.

3TC7 contactors

3TC74 contactors Size 12, DC and AC operation

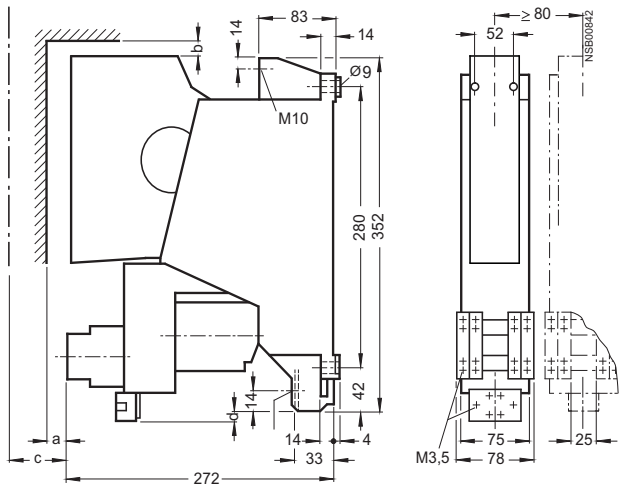

Dimensions	Minimum clearance from insulated components	Minimum clearance from grounded components
a	≥ 20	≥ 50
b	≥ 10	≥ 25
c	≥ 180 (clearance for removing arc chute)	

3TC78 contactors Size 12, DC and AC operation

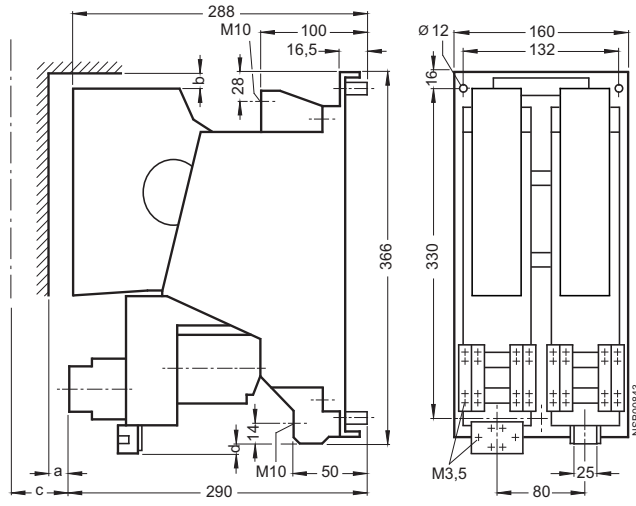

Dimensions	Minimum clearance from insulated components	Minimum clearance from grounded components
a	≥ 20	≥ 50
b	≥ 10	≥ 25
c	≥ 180 (clearance for removing arc chute)	
d	Coil terminal 3TC78 14-0E: 8 mm 3TC78 14-1C: 16 mm	

3TX2 746-2. varistors for 3TC74 and 3TC78 contactors

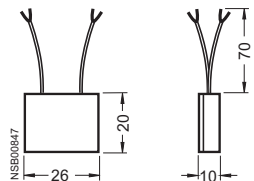

Project planning aids

Contactors with extended operating range 0.7 to 1.25 x U_s

3TC44 17-0L contactors, size 2, DC operation

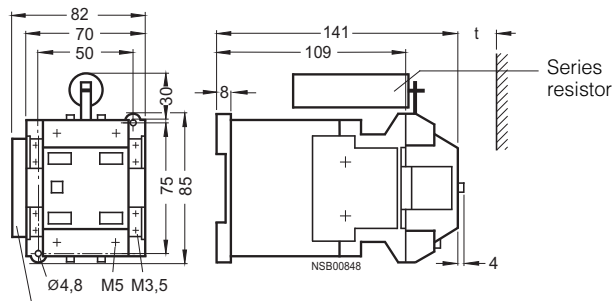

Varistor

t = minimum clearance from insulated components: 15 mm (600 V and 750 V)
from grounded components: 30 mm (600 V and 750 V)

Additional space requirements for mounting resistors and varistors

For 3TB50 to 3TB56, 3TC48 to 3TC56 contactors

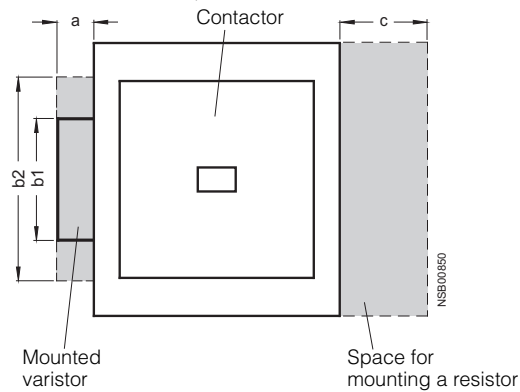

Separately mounted series resistor

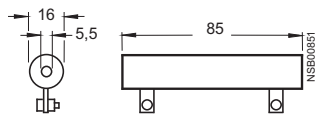

For contactors	Additional space requirements for series resistor for varistor			
	c	a	b ₁	b ₂ *)
3TB50	30	13	70	110
3TB52, 3TB54, 3TB56	--	15	82	120
3TC48	30	13	70	110
3TC52, 3TC56	--	15	82	120

*) Terminal compartment.

For contactors	Number of series resistors
3TB52, 3TC52	1
3TB54, 3TB56	2
3TC56	2

3TF2 contactors for switching motors, width 45 mm, size S00

3TF20, 3TF28,

with 1 auxiliary contact, with screw terminals, AC and DC operation, without or with overload relay (3UA7),

- ① 3TX4 490 surge suppressor
- ② Additional module (on overload relay)

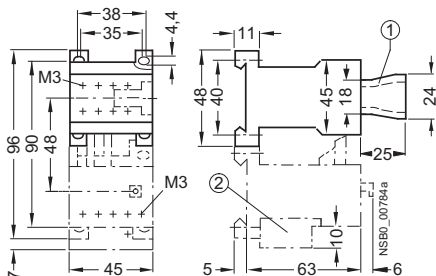

3TF20, 3TF22, 3TF28, 3TF29

with 2 to 5 auxiliary contacts, with screw terminals, AC and DC operation, without or with overload relay

- ① 3TX4 490 surge suppressor
- ② Additional module (on overload relay)
- ③ Auxiliary switch block

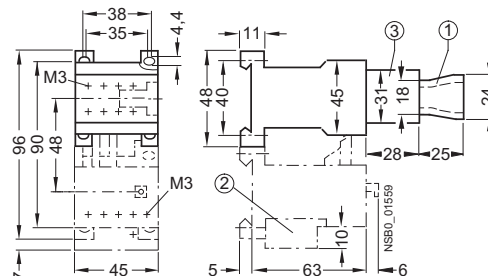

3TF20

with flat connectors 6.3 mm x 0.8 mm, for snap-on and screw fixing, AC and DC operation

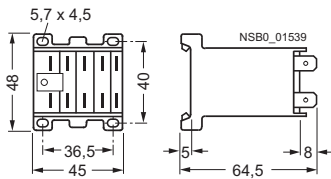

3TF20

with flat connectors 6.3 mm x 0.8 mm, for screw fixing (diagonal), AC and DC operation

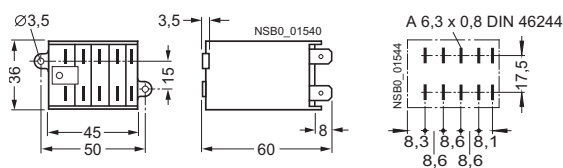

Grid size for flat connectors

3TF20

with solder pin connections for printed circuit boards for screw fixing (diagonal), AC and DC operation

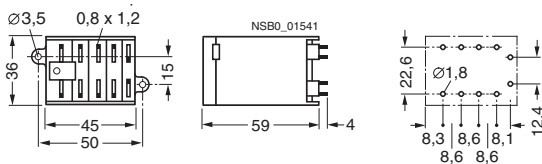

Hole pattern for solder pin connections

3TX4 491-2A plug-in base

with solder pin connections for printed circuit boards

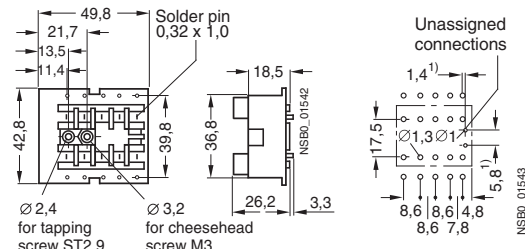

Hole pattern for plug-in base

3TX4 490 OFF-delay device

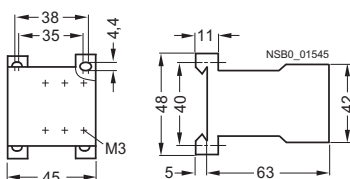

1) Holes required only for integrated overvoltage damping in the plug-in base.

Controls – Contactors and Contactor Assemblies

Project planning aids

3TK20 contactors, width 45 mm, size S00

3TK20

with screw terminals, for snap-on and screw fixing, AC and DC operation

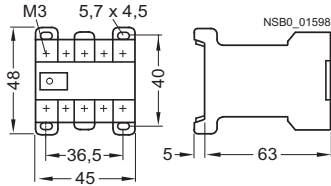

3TK20

with flat connectors 6.3 mm x 0.8 mm, for snap-on and screw fixing, AC and DC operation

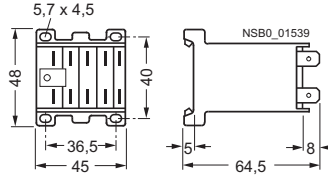

3TK20

with flat connectors 6.3 mm x 0.8 mm, for screw fixing (diagonal), AC and DC operation

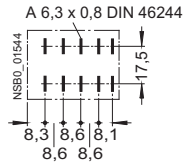
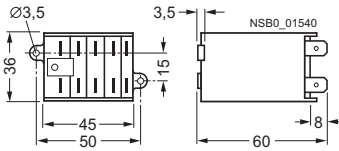

Grid size for flat connectors

3TK20

with solder pin connections for printed circuit boards, for screw fixing (diagonal), AC and DC operation

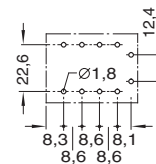
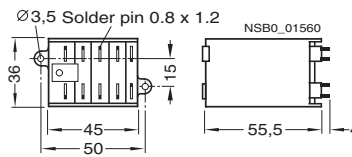

Hole pattern for solder pin connections

3TX4 491-2A plug-in base

with solder pin connections for printed circuit boards

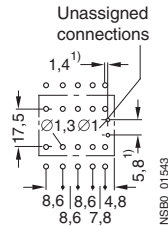
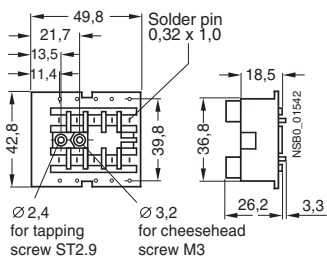

Hole pattern for plug-in base

1) Holes required only for integrated overvoltage damping in the plug-in base.

3TH2 contactor relays, width 45 mm, size S00

3TH20 with 4 contacts
with screw terminals,
AC and DC operation

- ① 3TX4 490 surge suppressor

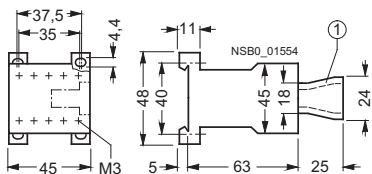

3TH20 with 4 contacts
AC and DC operation

- ① 3TX4 490 surge suppressor

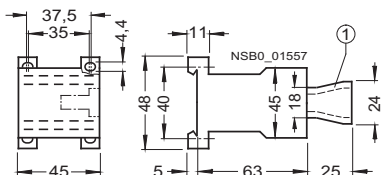

3TH20
with flat connectors 6.3 mm x 0.8 mm,
for snap-on and screw fixing,
AC and DC operation

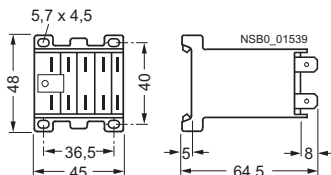

3TH20 with 6 and 8 contacts,
3TH22 with 8 contacts
with screw terminals,
AC and DC operation

- ① 3TX4 490 surge suppressor
- ② Auxiliary switch block

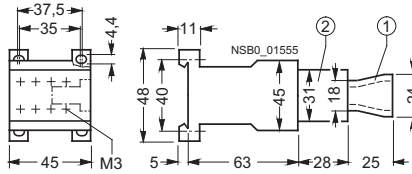

3TH20 with 6 and 8 contacts,
3TH22 with 8 contacts
AC and DC operation

- ① 3TX4 490 surge suppressor
- ② Auxiliary switch block

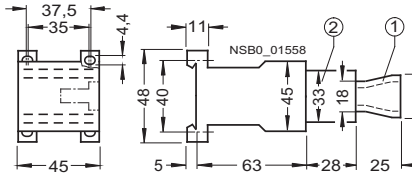

3TH20
with solder pin connections for printed circuit boards
for screw fixing (diagonal),
AC and DC operation

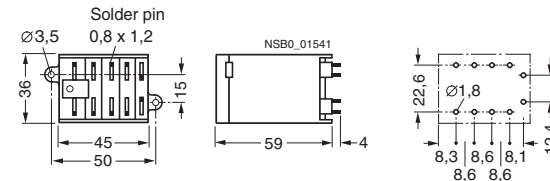

Hole pattern
for solder pin
connections

3TX4 491-2A plug-in base
with solder pin connections for printed circuit boards

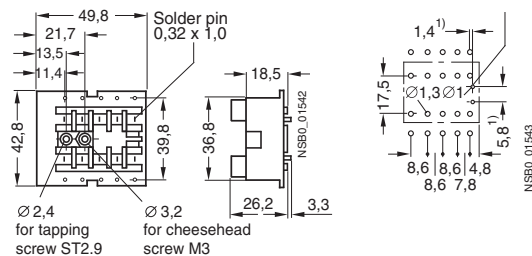

Hole pattern for
plug-in base

1) Holes required only for integrated overvoltage damping in the plug-in base.

3TX4 490 OFF-delay device

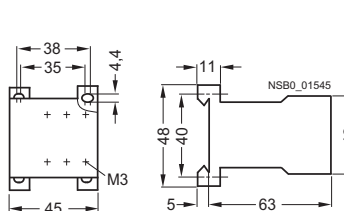

Controls – Contactors and Contactor Assemblies

Project planning aids

3TH27 latched contactor relays, width 90 mm, size S00

3TH27 with 4 contacts
with screw terminals,
for screw and snap-on mounting,
AC and DC operation

① 3TX4 490
surge suppressor

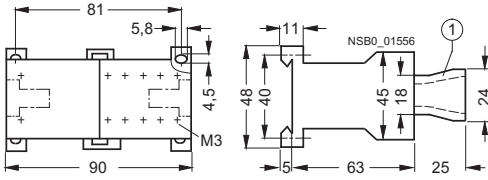

Coupling relays in industrial enclosure

3RS18

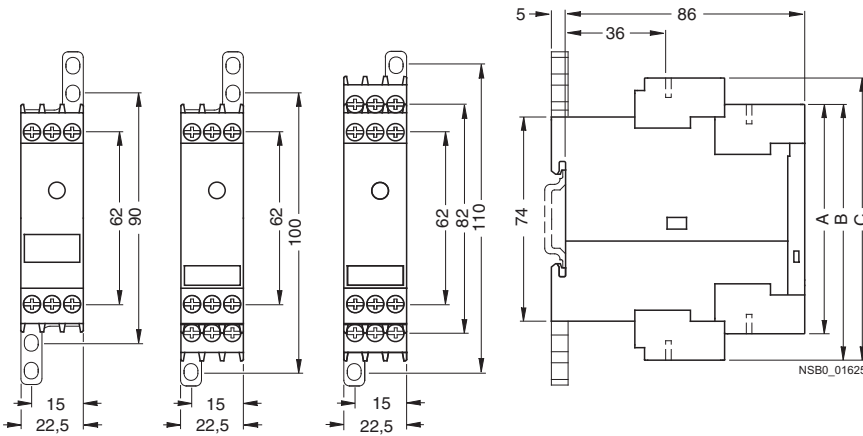

	A	B	C
	3RS18 00-.A	3RS18 00-.B	3RS18 00-.H
Removable terminals			
Spring-type terminals	84	94	103
Screw terminals	83	92	102

Coupling relays with narrow design

3TX7 002, 3TX7 003 coupling links in terminal block design

**3TX7 00 .-1AB . . . ,
3TX7 00 .-2A . . . ,
3TX7 002-3AB01**

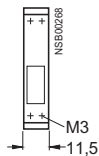

**3TX7 002-3AB00,
3TX7 002-4A . . .**

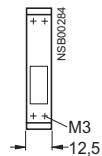

**3TX7 00 .-1BB00,
3TX7 00 .-1BF00,
3TX7 002-2BF02**

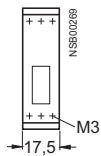

**3TX7 00 .-1CB00,
3TX7 002-1FB02**

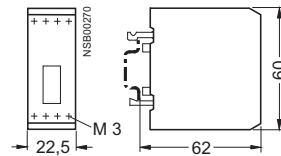

3TX7 004, 3TX7 005 coupling links in double-decker design

**3TX7 00 .-1MB00,
3TX7 00 .-1MF00,
3TX7 00 .-1L . 0 . . ,
3TX7 00 .-2M . . .
relay coupling links**

**3TX7 00 .-1AB10,
3TX7 00 .-1BB00,
3TX7 00 .-1BB10,
3TX7 00 .-1CB00,
3TX7 00 .-1BF05
relay coupling links**

**3TX7 00 .-3AB04,
3TX7 00 .-4AB04,
3TX7 00 .-3PB . . ,
3TX7 00 .-3PG74,
3TX7 00 .-3RB43
semiconductor coupling links**

**3TX7 00 .-3AC04,
3TX7 00 .-3AC14,
3TX7 00 .-3AC03
semiconductor coupling links**

**3TX7 00 .-1HB00
relay coupling links**

**3TX7 00 .-1GB00
relay coupling links**

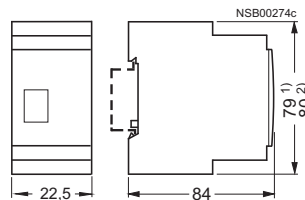
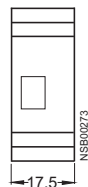
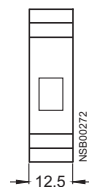
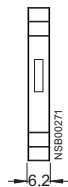

**3TX7 014, 3TX7 015
relay couplers with plug-in design**

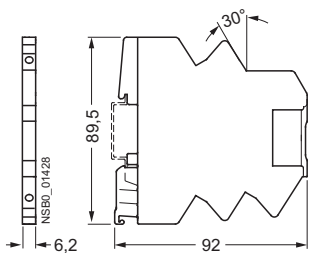

**3TX7 014-7CE00
galvanic isolation plate**

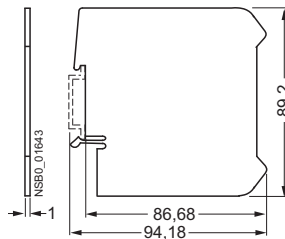

**3TX7 014-7AA00
connecting comb, 16-pole**

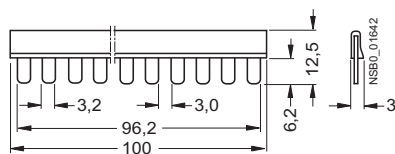

**3TX7 014-7B.0.
individual relay module**

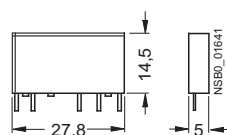

- 1) Dimensions for 3TX7 004 coupling links (screw terminals).
- 2) Dimensions for 3TX7 005 coupling links (spring-type terminals).

Project planning aids

LZS:PT relay couplers

Complete units, 11- and 14-pole, PT series

LZS:PT3A5

LZS:PT5A5

Standard plug-in base with screw terminals

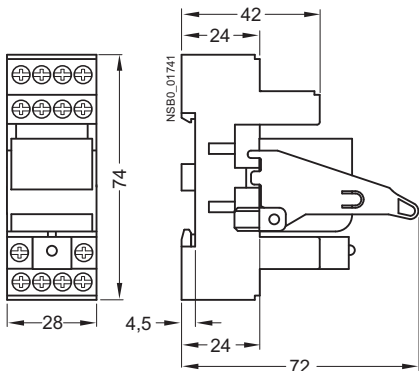

LZS:PT5B5

Plug-in base with logical isolation and screw terminals

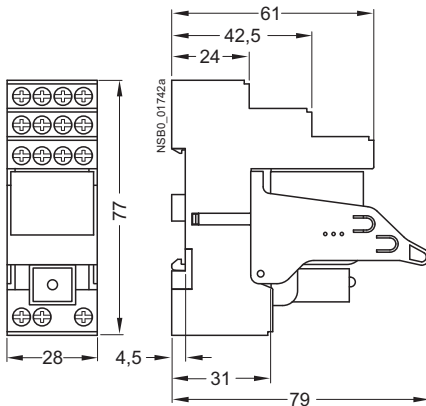

LZS:PT5D5

Plug-in base with logical isolation and plug-in terminals

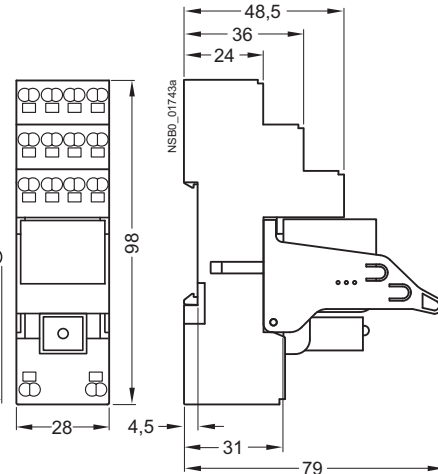

LZX industrial relays, 8-, 11-, and 14-pole, PT series

LZX:PT270, 8-pole

2 CO

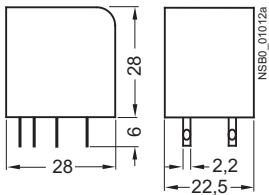

LZX:PT370, 11-pole

3 CO

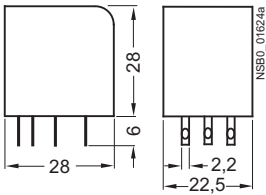

LZX:PT520, LZX:PT570, LZX:PT580, 14-pole

4 CO

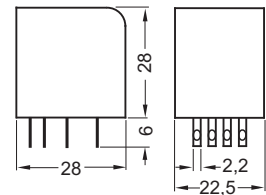

Plug-in bases for PT series

LZS:PT78740

with screw terminals

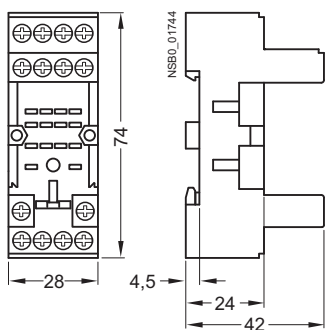

LZS:PT78742

with logical isolation and screw terminals

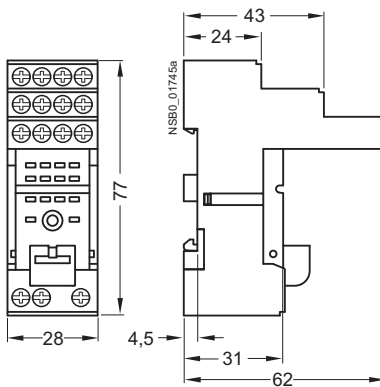

LZS:PT7874P

with logical isolation and plug-in terminals

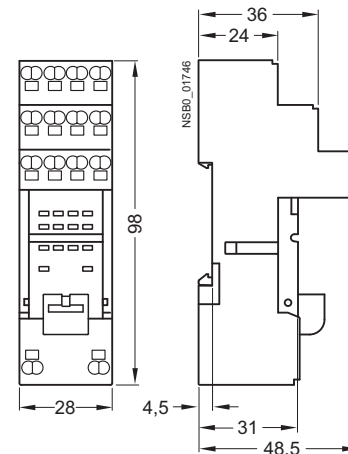

LZS:RT relay couplers

Complete units, 8-pole, 5 mm pinning, RT series

**LZS:RT3A4;
LZS:RT4A4**

Standard plug-in base with screw terminals

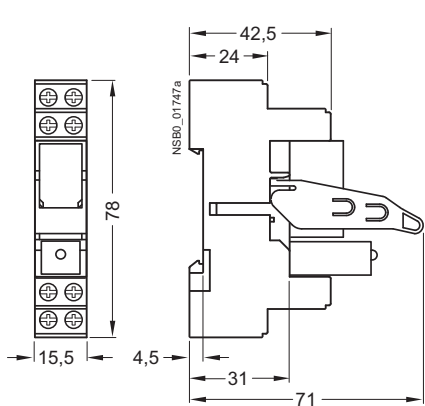

**LZS:RT3B4;
LZS:RT4B4**

Plug-in base with logical isolation and screw terminals

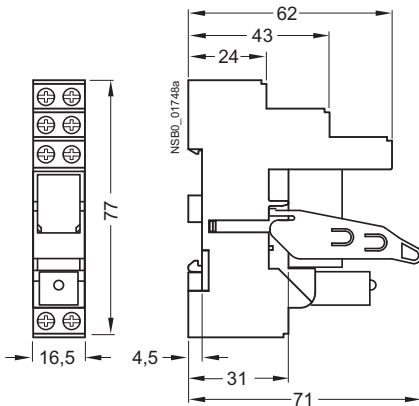

**LZS:RT3D4;
LZS:RT4D4**

Plug-in base with logical isolation and plug-in terminals

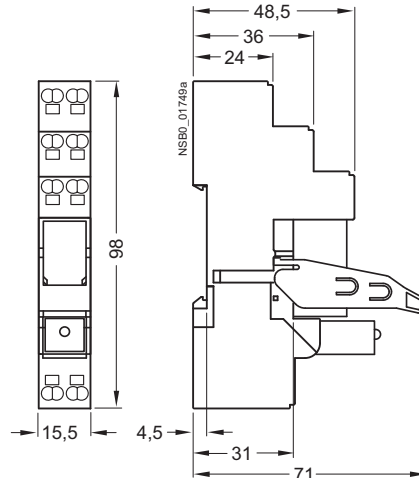

LZX:RT3; LZX:RT4 print relays

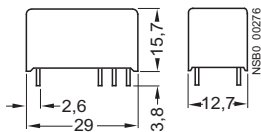

Plug-in bases for RT series

LZS:RT78725

with screw terminals

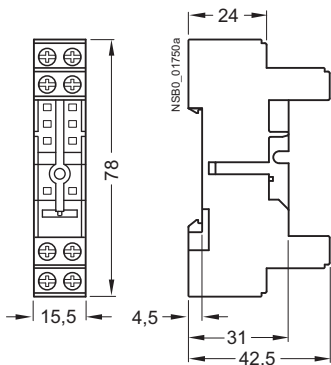

LZS:RT78726

with logical isolation and screw terminals

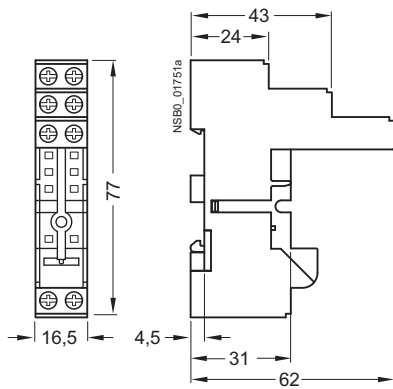

LZS:RT7872P

with logical isolation and plug-in terminals

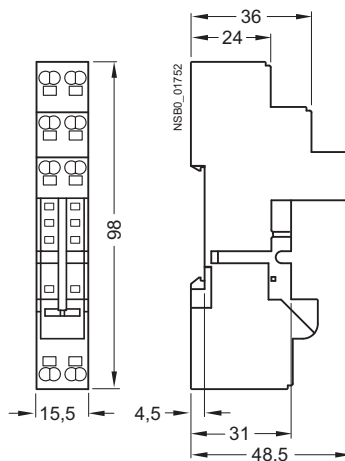

Project planning aids

LZX:MT relay couplers

Industrial relays, 11-pole, MT series

LZX:MT32

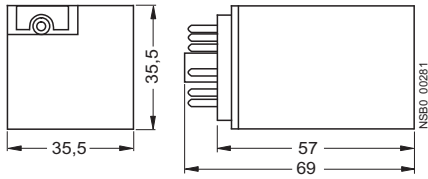

LZS:MT78750 plug-in bases
for industrial relays

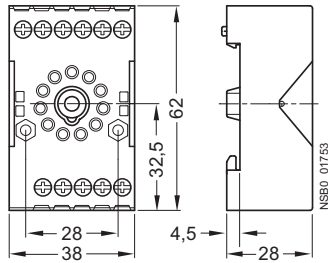

3

Schematics

Internal circuit diagrams for 3RT1 contactors and accessories (valid for screw and Cage Clamp terminals)

Size S00

Terminal designations according to EN 50012

3RT10 1 contactors

1 NO

Ident. No.: 10E

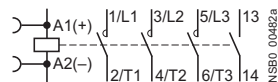

1 NC

01

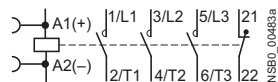

3RT10 1 contactors (with 1 NO)

with front-mounted 3RH19 11-.H... auxiliary switch blocks

1 NO + 1 NC

Ident. No.: 11E

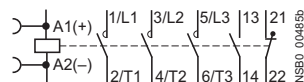

2 NO + 2 NC

22E

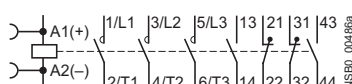

2 NO + 3 NC

Ident. No.: 23E

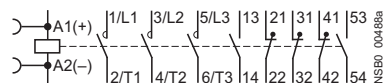

3 NO + 2 NC

32E

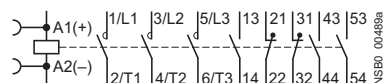

Size S0 to S3

Terminal designations according to EN 50012

3RT10 . . . X . 40-0LA2 contactors

Varistor built-in

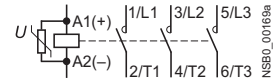

Contactors with 4 main contacts, size S00

Terminal designations according to EN 50005

3RT13 and 3RT15 contactors

4 NO

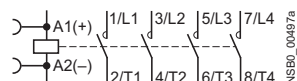

2 NO + 2 NC

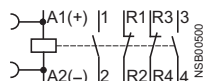

(3RH19 11 auxiliary switch blocks acc. to EN 50005 can be snapped on)

Surge suppressors for sizes S00 to S3 (coded plug-in direction; exception: for 3RT19 16-1T... diode assembly designation with +/-)

Diode



Diode assembly



Varistor



RC element



Diode with LED



Varistor with LED



1) Not for 3RT12 vacuum contactors.

Size S0 to S12

Terminal designations according to EN 50012

3RT10 2, 3RT10 3 contactors

3RT10 5 to 3RT10 7, 3RT12, 3RT14 contactors

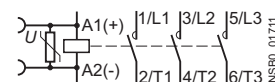
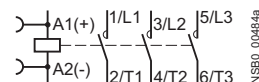

3RT10 2 and 3RT10 3, 3RT14 contactors

with front-mounted 4-pole 3RH19 21-.HA22 auxiliary switch block

2 NO + 2 NC

Ident. No.: 22E

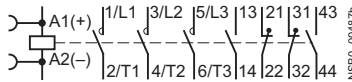

Contactors 3RT1. 5, 3RT1. 6, 3RT1. 7 (sizes S6, S10, S12) with front-mounted 4-pole 3RH19 21-.HA22 auxiliary switch block or with lateral 2-pole 3RH19 21-1DA11 auxiliary switch blocks

2 NO + 2 NC

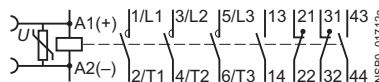

4-pole 3RH19 21-.HA. ./- .XA. . auxiliary switch blocks, for snapping onto the front¹⁾

3 NO + 1 NC

Ident. No.: 31

3RH19 21-.HA..

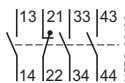

2 NO + 2 NC

Ident. No.: 22

3RH19 21-.HA..

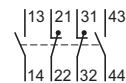

2 NO + 2 NC

Ident. No.: 13

3RH19 21-.XA..

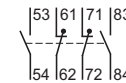

1 NO + 3 NC

Ident. No.: 13

3RH19 21-.HA..

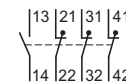

First laterally mountable 3RH19 21-.DA11, 3RH19 21-2DE11 auxiliary switch block (solid-state compatible)

1 NO + 1 NC

Left

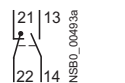

1 NO + 1 NC

Right

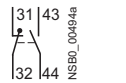

Second laterally mountable 3RH19 21-.JA11, 3RH19 21-2JE11 auxiliary switch block (solid-state compatible)

(only for sizes S3 to S12)

1 NO + 1 NC

Left

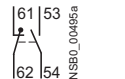

1 NO + 1 NC

Right

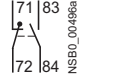

Contactors with 4 main contacts, sizes S0 to S3

Terminal designations according to EN 50005

3RT13 and 3RT15 contactors

4 NO

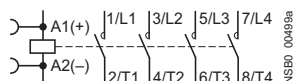

2 NO + 2 NC

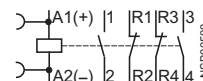

(3RH19 21 auxiliary switch blocks acc. to EN 50005 can be snapped on)

Project planning aids

Internal circuit diagrams for 3RT1 contactors and accessories (valid for screw and Cage Clamp terminals)

Accessories for size S00 contactors and contactor relays Terminal designations according to EN 50005

3RH19 11-.F... auxiliary switch blocks and 3RH19 11-.NF... solid-state compatible auxiliary switch blocks
(solid-state compatible auxiliary switch blocks)

2 NO
Ident. No.: 20

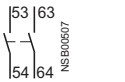

1 NO + 1 NC
11



2 NC
02



1 NO + 1 NC
11 U



with make-before-break

4 NO
Ident. No.: 40

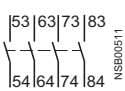

3 NO + 1 NC
31

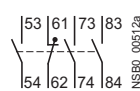

2 NO + 2 NC
22

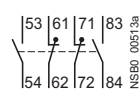

2 NO + 2 NC
22 U

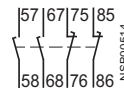

with make-before-break

2 NO + 2 NC
11/11 U

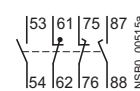

1 NO + 1 NC standard
1 NO + 1 NC with
make-before-break
Internal wiring

3RH19 11-1AA.. and 3RH19 11-1BA..
auxiliary switch blocks,
for snapping onto the front,
cable entry from above or below

1 NO



1 NC



2 NO



1 NO + 1 NC

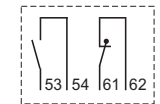

Example of
1 NO + 1 NC, cable
entry from below

Accessories for size S00 contactors and contactor relays Terminal designations according to DIN 46199 Part 5

3RT19 16-2E.../2F.../2G... solid-state, time-delay auxiliary switch blocks

1 NO + 1 NC
With ON-delay

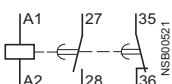

1 NO + 1 NC
OFF-delay

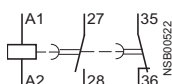

2 NO
Wye-delta function

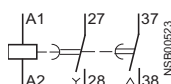

(Integrated varistors not shown)

Accessories for size S0 to S12 contactors Terminal designations according to EN 50005

3RH19 21-.F... auxiliary switch blocks, 4-pole,
for snapping onto the front¹⁾

4 NO
Ident. No.: 40

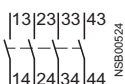

3 NO + 1 NC
31

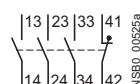

2 NO + 2 NC
22

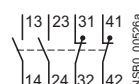

4 NC
04

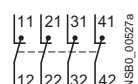

2 NO + 2 NC
22 U

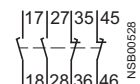

with make-before-break

3RH19 21-.CA... auxiliary switch blocks, 1-pole,
for snapping onto the front¹⁾

1 NO



1 NC



1 NO



1 NC



(Terminal designations according to EN 50005 or EN 50012)

¹⁾ Not for 3RT12 vacuum contactors.

Internal circuit diagrams for 3RT1 contactors and accessories (valid for screw and Cage Clamp terminals)

Accessories for size S0 to S12 contactors
Terminal designations according to EN 50005

3RH19 21-1LA... and 3RH19 21-1MA... auxiliary switch block, 2-pole, for snapping onto the front¹⁾ cable entry from above or below

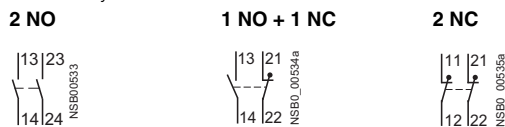

Internal wiring

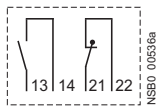

Example of 1 NO + 1 NC, cable entry from below

3RH19 21-.FE22 solid-state compatible auxiliary switch block, 4-pole, for snapping onto the front¹⁾

2 NO + 2 NC
 Ident. No.: 22

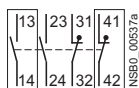

3RH19 21-.EA... first laterally mountable auxiliary switch blocks (left)

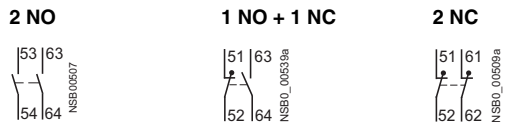

3RH19 21-.EA... first laterally mountable auxiliary switch blocks (right)

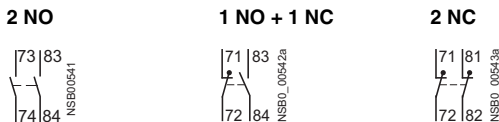

3RH19 21-.KA... second laterally mountable auxiliary switch blocks (left) (only for sizes S3 to S12)

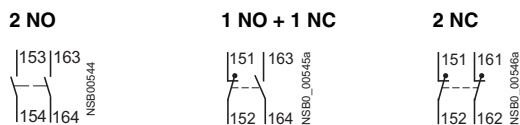

3RH19 21-.KA... second laterally mountable auxiliary switch blocks (right)

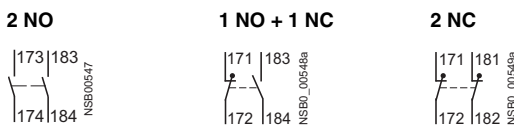

Accessories for size S0 to S12 contactors
Terminal designations according to DIN 46199 Part 5

3RT19 26-2E.../2F.../2G... solid-state, time-delay auxiliary switch blocks

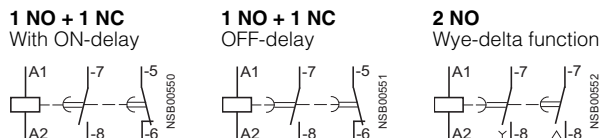

3RH19 24-1GP11 coupling link with surge suppression

Connection diagram

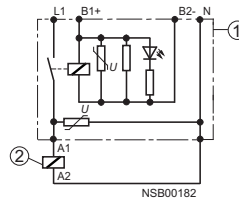

① Coupling link
 ② Contactor

Connection example

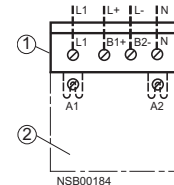

① Coupling link
 ② Contactor

Accessories for contactors size S0
Terminal designations, pneumatic delay block

With ON-delay 3RT19 26-2PA. 1	OFF-delay 3RT19 26-2PR. 1
----------------------------------	------------------------------



¹⁾ Not for 3RT12 vacuum contactors.

Controls – Contactors and Contactor Assemblies

Project planning aids

Schematics for accessories for sizes S00 to S3

3RT19 16-2BK01, 110 V UC
3RT19 16-2BL01, 230 V UC OFF-delay devices

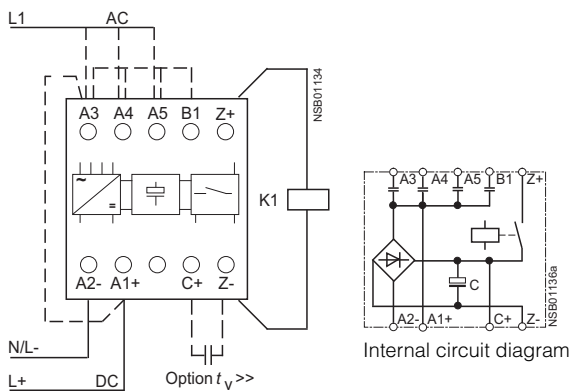

3RT19 16-2BE01, 24 V DC OFF-delay devices

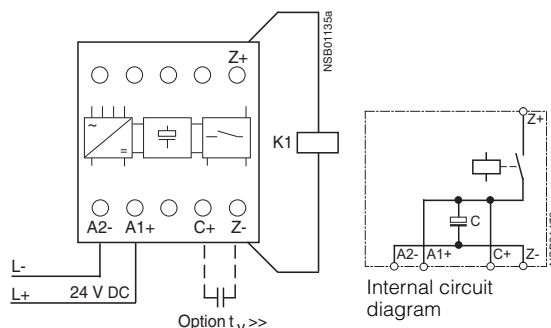

3RT19 16-2BK01, 110 V UC

110 V UC	A1	A3	A4	A5	B1	A2	Z+	Z-	t_v (ms) >
S00 DC	L+					L-			130
50 Hz		L1				N	3RT1. 1.-.BF4. 3RH1. ...-BF4.		130
60 Hz		L1				N			130
S0 DC	L+					L-			100
50 Hz		L1				N	3RT1. 2.-.BF4.		100
60 Hz		L1				N			100

3RT19 16-2BE01, 24 V DC

24 V DC	A1	A2	Z+	Z-	t_v (ms) >
S00	L+	L-	3RT1. 1.-.BB4. 3RH1. ...-BB4.		250
S0	L+	L-	3RT1. 2.-.BB4.		150
S2	L+	L-	3RT1. 3.-.BB4.		90
S3	L+	L-	3RT1. 4.-.BB4.		70

3RT19 16-2BL01, 230 V UC

230 V UC	A1	A3	A4	A5	B1	A2	Z+	Z-	t_v (ms) >
S00 DC	L+					L-			600
50 Hz		L1				N	3RT1. 1.-.BM4. 3RT1. 1.-.BP4. 3RH1. ...-BM4.		600
60 Hz				L1		N	3RH1. ...-BP4.		600
S0 DC	L+					L-			400
50 Hz		L1				N	3RT1. 2.-.BM4. 3RT1. 2.-.BP4.		400
60 Hz				L1		N			400

Operation after OFF-delay

(Contactor only switches off with delay in case of voltage failure)

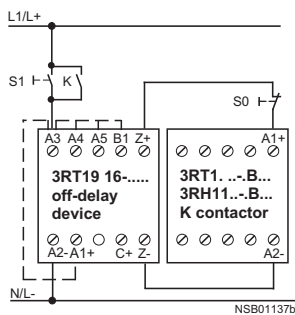

Schematic circuit diagram

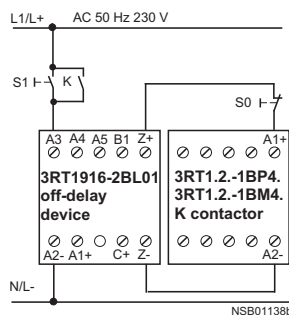

Typical circuit diagram:
Contactor size S0,
DC operation, at AC 50 Hz 230 V

Operation before OFF-delay

(Contactor always switches off with delay)

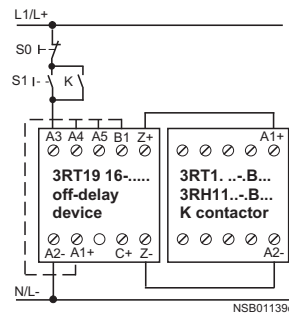

Schematic circuit diagram

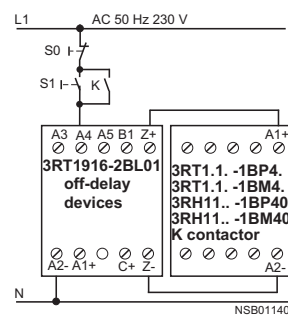

Typical circuit diagram:
Contactor size S00,
DC operation, at AC 50 Hz 230 V

Circuit diagrams for accessories for sizes S00 to S3

Accessories for size S00 to S3 contactors and contactor relays

Solid-state time-delay blocks
(note planning aids on Page 3/167!)

3RT19 16-2C...
With ON-delay
Size S00

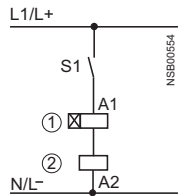

3RT19 16-2D...
OFF-delay (with auxiliary voltage)
Size S00

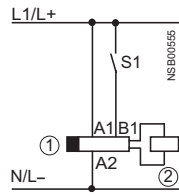

3RT19 26-2C...
With ON-delay
Sizes S0 to S3

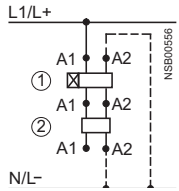

A2 can be connected to N(L-) using either the contactor or the timing relay. --- optionally connect

3RT19 26-2D...
OFF-delay (with auxiliary voltage)
Sizes S0 to S3

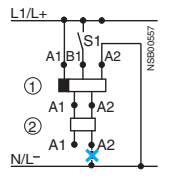

A2 must only be connected to N(L-) from the timing relay.

- ✗ Do not connect
- ① Timing relay block
- ② Contactor

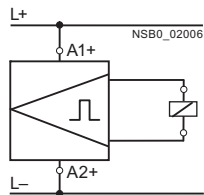

Circuit diagram for railway-type contactors with solid-state coil excitation

3RT16 capacitor contactors

Size S00

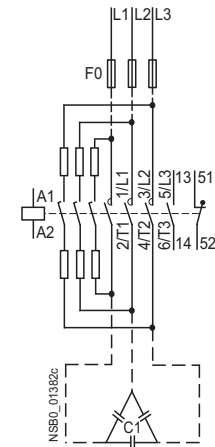

Sizes S0 and S3

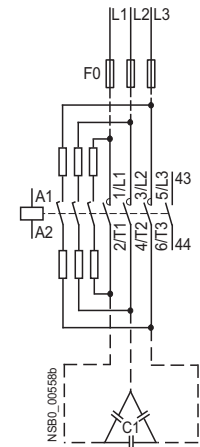

Project planning aids

Internal circuit diagrams for accessories of size S00 to S3

Contactors with extended operating range 0.7 to 1.25 × U_s

Size S00

Terminal designations according to EN 50012

3RT10 17-2K.42-0LA0 contactors

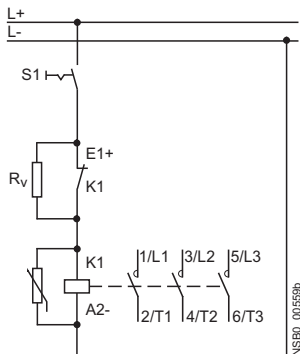

Series resistor R_v plugged on, NC contact prewired.

3RT10 17-2K.41/2K.42 contactor
Varistor integrated
Size S00

1 NO

Ident. No.: 10E

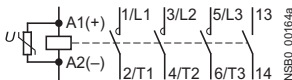

1 NC

01E

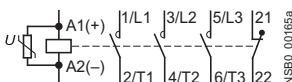

Terminal designations according to EN 50011

3RH11 22-2K.40-0LA0 contactor relays

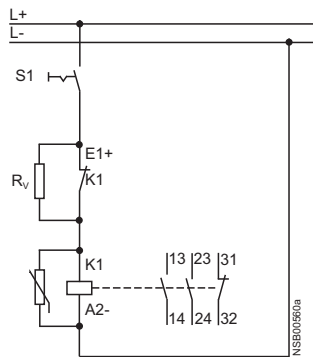

2 NO + 1 NC unassigned
Series resistor R_v plugged on, NC contact prewired.

3RH11 22-2K.40 contactor relay
Varistor integrated
Size S00

2 NO + 2 NC

22E

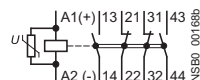

Size S00 to S3

Terminal designations according to EN 50012

3RT10 2.-, 3RT10 3.-, 3RT10 4.-3K.44-0LA0 contactors with front-mounted 4-pole 3RH19 21-1HA22 auxiliary switch block

2 NO + 2 NC

Ident. No.: 22

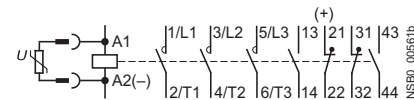

Circuit diagram of the series resistor wiring

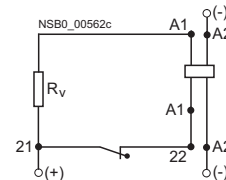

The series resistor is supplied separately packed. The 21/22 NC contact is necessary to wire the series resistor.

3RT10 25-3K.40 contactor
Varistor integrated
Size S0

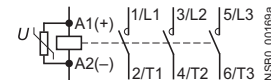

(Two single-pole auxiliary switch blocks can be snapped on)

Position of the terminals for 3RT1 contactors and accessories (valid for screw and Cage Clamp terminals)

Size S00

Terminal designations according to EN 50012

3RT10 1 contactors, 3RT10 1 coupling relays
3RT10 17-2K.4. contactors with extended operating range

1 NO

Ident. No.: 10E

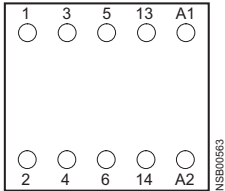

NSB00563

1 NC

01

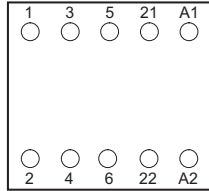

NSB0_00564a

3RT10 1 contactors (with 1 NO contact)
with front-mounted 3RH19 11-.H... auxiliary switch blocks

1 NO + 1 NC

Ident. No.: 11E

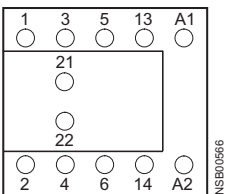

NSB00566

2 NO + 2 NC

22E

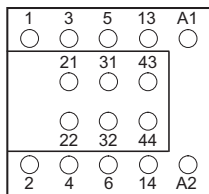

NSB00567

2 NO + 3 NC

Ident. No.: 23E

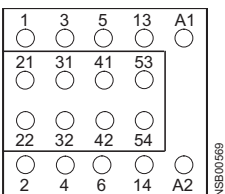

NSB00569

3 NO + 2 NC

32E

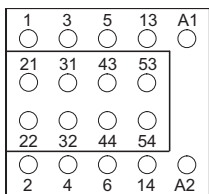

NSB00570

Size S0 to S3

Terminal designations according to EN 50012

3RT10 . . . X . 40-0LA2 contactors
with solid-state control unit

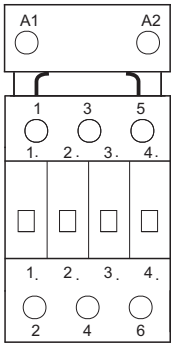

NSB01390

Size S0 to S12

Terminal designations according to EN 50012

3RT10 2, 3RT 10 3,
3RT10 4, 3RT14 46 contactors,
3RT10 2 coupling relays
3RT10 25-3K.40 contactors with
extended operating range

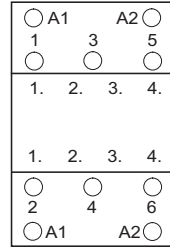

NSB00565

3RT10 2, 3RT10 3, 3RT10 4
contactors
with front-mountable
4-pole 3RH19 21-. HA31
auxiliary switch block

3 NO + 1 NC

Ident. No.: 31 E

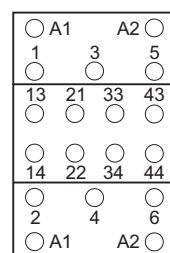

NSB0_01348

First laterally mountable
3RH19 21-.DA11¹⁾
auxiliary switch block
can be mounted on the left or
right

1 NO + 1 NC

Left

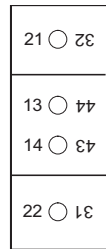

NSB00571

Right

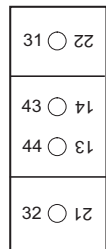

NSB00572

3RT10 2, 3RT10 3, 3RT10 4
contactors
with front-mounted
4-pole 3RH19 21-. HA22
auxiliary switch block

2 NO + 2 NC

Ident. No.: 22 E

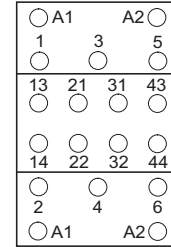

NSB00568

3RT10 2, 3RT10 3, 3RT10 4
contactors
with front-mountable
4-pole 3RH19 21-. HA13
auxiliary switch block

1 NO + 3 NC

13 E

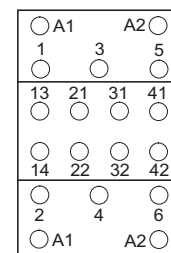

NSB01349

Second laterally mountable
3RH19 21-.JA11¹⁾
auxiliary switch block
can be mounted on the left or
right
(only for sizes S3 to S12)

1 NO + 1 NC

Left

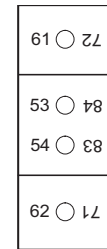

NSB00573

Right

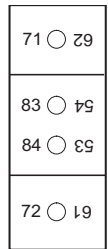

NSB00574

¹⁾ Note location identifier. Can only be used if no 4-pole auxiliary switch block is snapped onto the front.

Project planning aids

Position of the terminals for 3RT1 contactors and accessories (valid for screw and Cage Clamp terminals)

Sizes S6 to S12

3RT1 .5, 3RT1 .6, 3RT1 .7 contactors

- With conventional operating mechanism (3RT1...-A...)

With laterally mountable auxiliary switch blocks
3RH19 21-1DA11
(for 2 NO + 2 NC, included in the contactors)
3RH19 21-1JA11
(can be extended to 4 NO + 4 NC)

2 NO + 2 NC or 4 NO + 4 NC

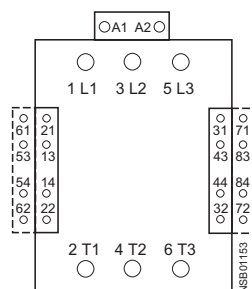

- With solid-state operating mechanism (3RT1...-N...)

With laterally mountable auxiliary switch blocks
3RH19 21-1DA11
(for 2 NO + 2 NC, included in the contactors)
3RH19 21-1JA11
(can be extended to 4 NO + 4 NC)

2 NO + 2 NC or 4 NO + 4 NC

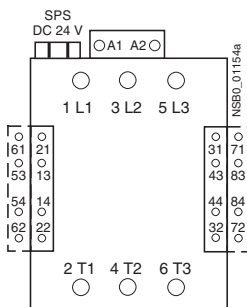

- With solid-state operating mechanism (3RT1...-P...)

With laterally mountable auxiliary switch blocks
3RH19 21-1DA11
(for 1 NO + 1 NC, included in the contactors)
3RH19 21-1JA11
(can be extended to 2 NO + 2 NC)

1 NO + 1 NC or 2 NO + 2 NC

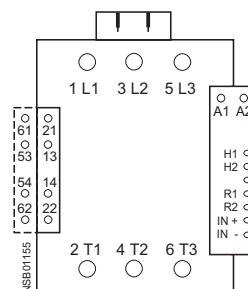

- With solid-state operating mechanism (3RT1...-Q...)

With laterally mountable auxiliary switch blocks
3RH19 21-1DA11
(for 1 NO + 1 NC, included in the contactors)
3RH19 21-1JA11
(can be extended to 2 NO + 2 NC)

1 NO + 1 NC or 2 NO + 2 NC

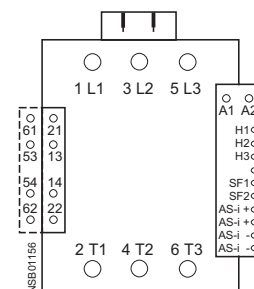

Contactors with 4 main contacts, size S00 Terminal designations according to EN 50005

3RT13 and 3RT15 contactors

4 NO

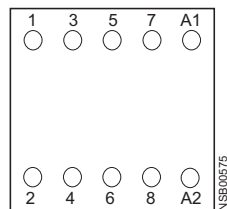

2 NO + 2 NC

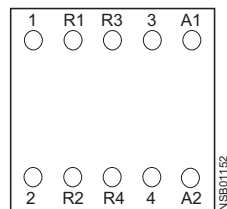

Contactors with 4 main contacts, sizes S0 to S3 Terminal designations according to EN 50005

3RT13 and 3RT15 contactors

4 NO

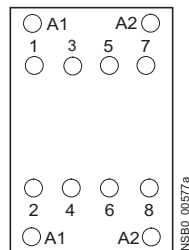

2 NO + 2 NC

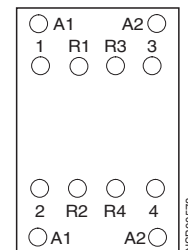

Accessories for size S00 contactors and contactor relays Terminal designations according to EN 50005

3RH19 11-.F... auxiliary switch blocks and 3RH19 11-.NF... solid-state compatible auxiliary switch blocks for snapping onto the front

2 NO

Ident. No.: 20

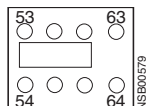

1 NO + 1 NC

11

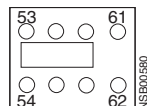

2 NC

02

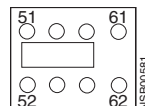

1 NO + 1 NC

11 U

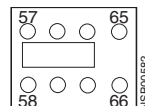

with make-before-break

4 NO

Ident. No.: 40

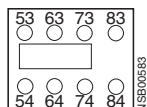

3 NO + 1 NC

31

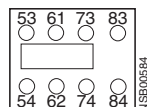

2 NO + 2 NC

22

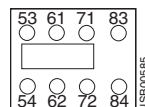

2 NO + 2 NC

22 U

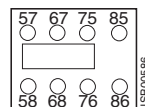

with make-before-break

2 NO + 2 NC

11/11 U

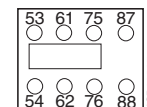

1 NO + 1 NC ON-delay
1 NO + 1 NC with make-before-break

Position of the terminals for 3RT1 contactors and accessories (valid for screw and Cage Clamp terminals)

Accessories for size S00 contactors and contactor relays
Terminal designations according to EN 50005

3RH19 11-1AA...
 auxiliary switch blocks for snapping onto the front
 Cable entry from above

1 NO

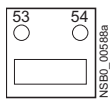

3RH19 11-1LA20

1 NC

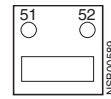

3RH19 11-1LA11

2 NO

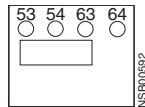

1 NO + 1 NC

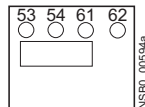

3RH19 11-1BA...
 auxiliary switch blocks for snapping onto the front
 Cable entry from below

1 NO

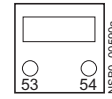

3RH19 11-1MA20

1 NC

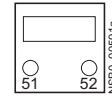

3RH19 11-1MA11

2 NO

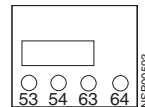

1 NO + 1 NC

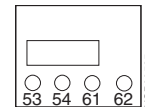

Terminal designations according to DIN 46199 Part 5

3RT19 16-2E.../2F.../2G... solid-state, time-delay auxiliary switch blocks

1 NO + 1 NC

With ON-delay

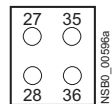

1 NO + 1 NC

OFF-delay

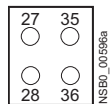

2 NO

Wye-delta function

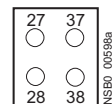

Accessories for size S0 to S12 contactors
Terminal designations according to EN 50005

3RH19 21-.F... auxiliary switch blocks, 4-pole,
 for snapping onto the front

4 NO

Ident. No.: 40

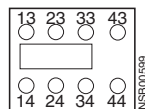

3 NO + 1 NC

31

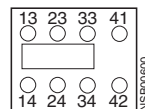

2 NO + 2 NC

22

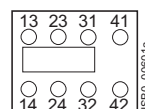

4 NC

04

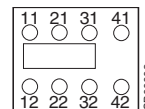

2 NO + 2 NC

22 U

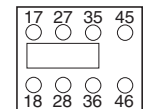

with make-before-break

3RH19 21-1LA... auxiliary switch blocks, 2-pole
 for snapping onto the front, cable entry from the top

2 NO

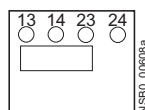

1 NO + 1 NC

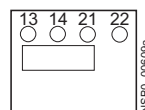

2 NC

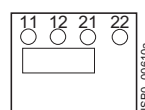

3RH19 21-1MA... auxiliary switch blocks, 2-pole,
 for snapping onto the front, cable entry from the bottom

2 NO

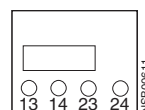

1 NO + 1 NC

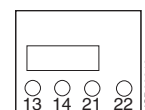

2 NC

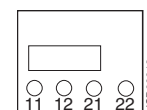

3RH19 21-.FE22 solid-state compatible auxiliary switch block, 4-pole,
 for snapping onto the front

2 NO + 2 NC

Ident. No.: 22

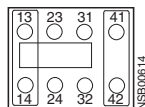

Terminal designations according to EN 50005 or EN 50012

3RH19 21-.CA... auxiliary switch blocks, 1-pole,
 for snapping onto the front

1 NO

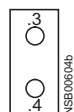

1 NC

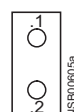

1 NO

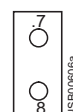

with extended contacting

1 NC



with extended contacting

Controls – Contactors and Contactor Assemblies

Project planning aids

Position of the terminals for 3RT1 contactors and accessories

Accessories for size S0 to S12 contactors Terminal designations according to EN 50005

First laterally mountable 3RH19 21-.EA.. auxiliary switch blocks (left)

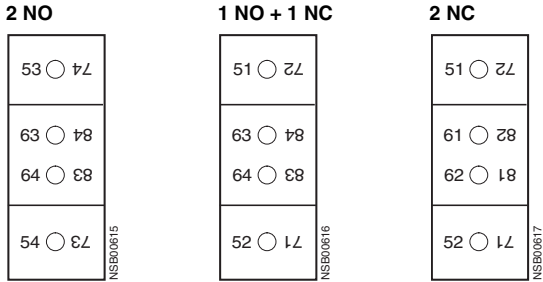

First laterally mountable 3RH19 21-.EA.. auxiliary switch blocks (right)

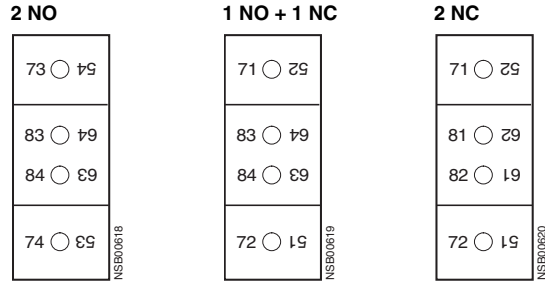

Second laterally mountable 3RH19 21-.KA.. auxiliary switch blocks (left)
(only for sizes S3 to S12; can only be used if no auxiliary switches are snapped onto to the front)

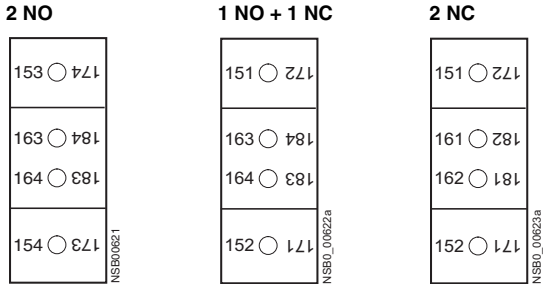

Second laterally mountable 3RH19 21-.KA.. auxiliary switch blocks (right)
(only for sizes S3 to S12; can only be used if no auxiliary switches are snapped onto to the front)

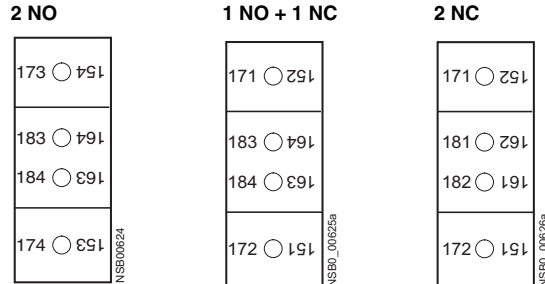

Accessories for size S0 to S12 contactors Terminal designations according to DIN 46199 Part 5

3RT19 26-2E.../2F.../2G... solid-state, time-delay auxiliary switch blocks

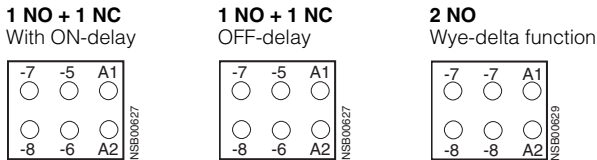

3RT16 capacitor contactors

Size S00
with 4-pole auxiliary switch block mounted on the front

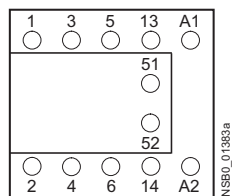

The auxiliary switch block contains 3 leading contacts (not shown), and one unassigned NO contact and one unassigned NC contact.

Size S0 and S3
with 4-pole auxiliary switch block mounted on the front

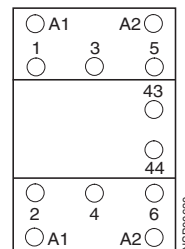

The auxiliary switch block contains 3 leading contacts (not shown) and one unassigned NO contact.

Position of the terminals for 3RT1 contactors and accessories**Contactors with extended operating range 0.7 to 1.25 × U_s
Size S00****Terminal designations according to EN 50012**

3RT10 17-2K.42-0LA0 contactors

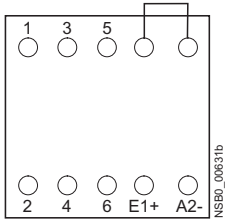

Series resistor R_V plugged on, NC contact prewired.
3RH19 11-2. . . . auxiliary switch blocks according to EN 50005 can be snapped on.

Terminal designations according to EN 50011

3RH11 22-2K.40-0LA0 contactor relays

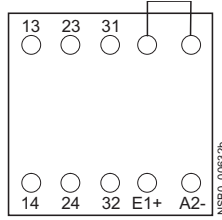

Series resistor R_V plugged on, NC contact prewired.
3RH19 11-2. . . . auxiliary switch blocks according to EN 50005 can be snapped on.

**Contactor relays with extended tolerance 0.7 to 1.25 × U_s
Size S00**

3RH11 22-2K.40 contactor relays

2 NO + 2 NC

Ident. No.: 22 E

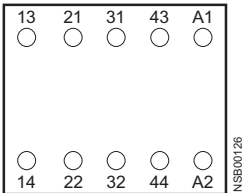

It is not possible to mount an auxiliary switch block.

**Contactors with extended operating range 0.7 to 1.25 × U_s
Size S0 to S3****Terminal designations according to EN 50012**3RT10 2.-, 3RT10 3.-, 3RT10 4.-3K.44-0LA0 contactors
with front 4-pole 3RH19 21-2HA22 auxiliary switch block**2 NO + 2 NC**

Ident. No.: 22 E

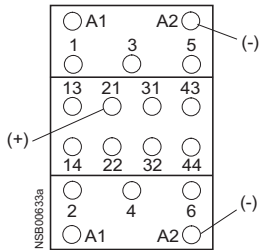

For circuit diagram of the series resistor wiring, see page 3/226.

Note:

For position of terminals for the 3RT10 17-2K.4. and 3RT10 25-3K.40 contactors see page 3/227.

Controls – Contactors and Contactor Assemblies

Project planning aids

Connection diagrams for 3RH1 contactor relays, size S00

Terminal designations according to EN 50011¹⁾

3RH11 contactor relays

4 NO

Ident. No.: 40E

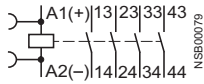

3 NO + 1 NC

31 E

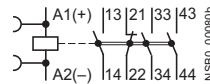

2 NO + 2 NC

22E

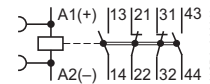

3RH11 40 contactor relays

with 3RH19 11-1GA. . .

3RH12 44, 3RH12 62 auxiliary switch blocks snapped onto the front

8 NO

Ident. No.: 80E

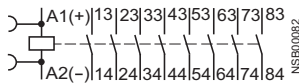

7 NO + 1 NC

71E

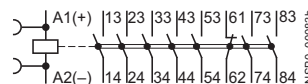

6 NO + 2 NC

62E



5 NO + 3 NC

Ident. No.: 53E

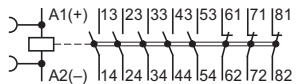

4 NO + 4 NC

44E

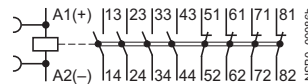

3RH14 latched contactor relays

4 NO

Ident. No.: 40E

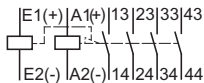

3 NO + 1 NC

31E

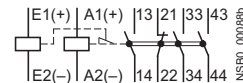

2 NO + 2 NC

22E

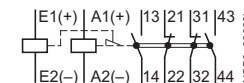

Surge suppressor (plug-in direction coded)

Diode



Diode assembly



Varistor



RC element



Diode with LED

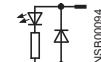

Varistor with LED

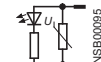

¹⁾ Positively-driven operation is assured likewise for auxiliary switch blocks according to EN 50005 in conjunction with 3RH11 contactor relays (basic units).

Connection diagrams for 3TH42 contactor relays with 8 contacts

Terminal designations according to EN 50011

8 NO

Ident. No.: 80E

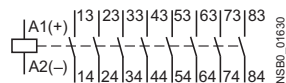

7 NO + 1 NC

71E

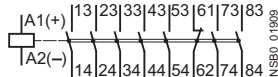

6 NO + 2 NC

62E

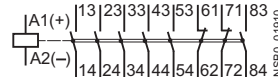

5 NO + 3 NC

Ident. No.: 53E

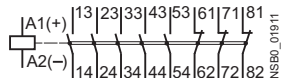

4 NO + 4 NC

44E

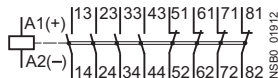

3 NO + 3 NC and 1 NO + 1 NC make-before-break

44E, U

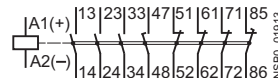

Circuit diagrams for 3TH42 contactor relays with 8 contacts

3TX4 180-0A NTC thermistor module

Switching examples

Momentary-contact operation

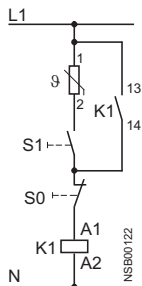

Maintained-contact operation

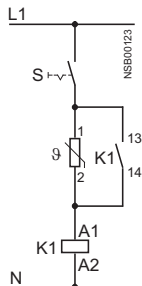

Position of the terminals for 3TH42 contactor relays with 8 contacts

8 NO

Ident. No.: 80E

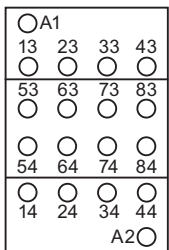

7 NO + 1 NC

71E

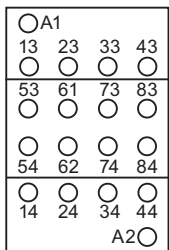

6 NO + 2 NC

62E

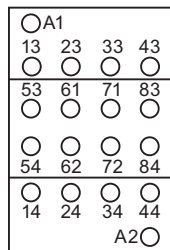

5 NO + 3 NC

53E

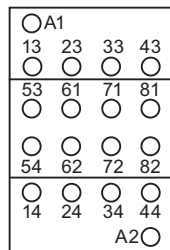

4 NO + 4 NC

44E

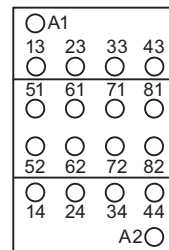

Controls – Contactors and Contactor Assemblies

Project planning aids

Connection diagrams for 3TH43 contactor relays with 10 contacts

Terminal designations according to EN 50011

10 NO

Ident. No.: 100E

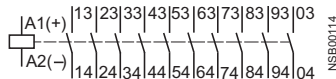

9 NO + 1 NC

91E

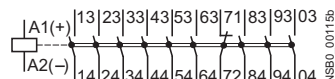

8 NO + 2 NC

82E

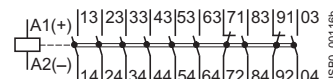

7 NO + 3 NC

Ident. No.: 73E

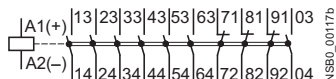

6 NO + 4 NC

64E

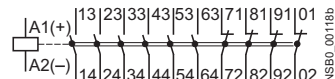

5 NO + 5 NC

55E

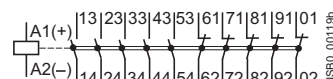

4 NO + 4 NC, 1 NO + 1 NC make-before-break

Ident. No.: 44E/11U

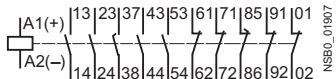

6 NO + 2 NC, 1 NO + 1 NC make-before-break

63E/11U

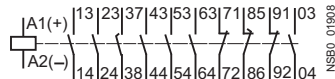

Circuit diagrams for 3TH43 contactor relays with 10 contacts

3TX4 180-0A NTC thermistor module
Switching examples

Momentary-contact operation

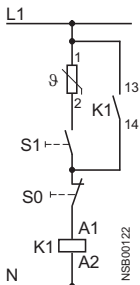

Maintained-contact operation

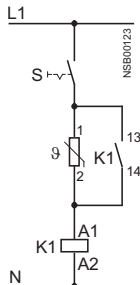

Position of the terminals for 3TH43 contactor relays with 10 contacts

10 NO

Ident. No.: 100E

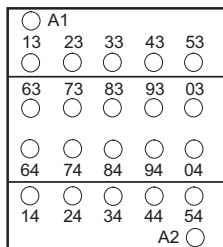

9 NO + 1 NC

91E

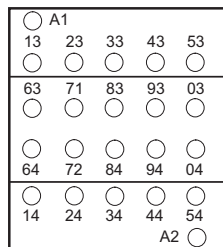

8 NO + 2 NC

82E

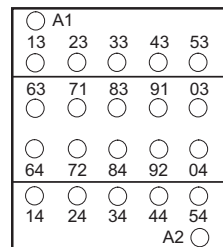

7 NO + 3 NC

73E

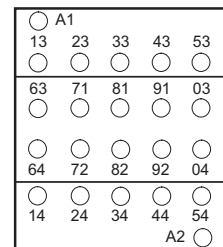

6 NO + 4 NC

Ident. No.: 64E

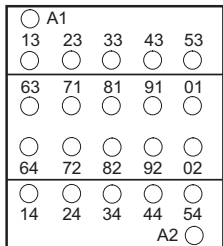

5 NO + 5 NC

55E

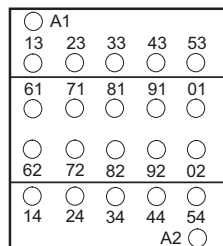

5 NO + 5 NC

55E, U

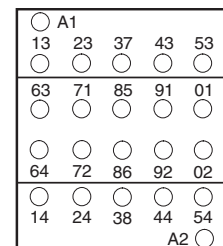

Position of the terminals for 3RH1 contactor relays, size S00

Terminal designations according to EN 50011

3RH11 contactor relays

4 NO

Ident. No.: 40E

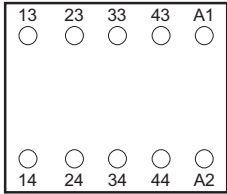

3 NO + 1 NC

31E

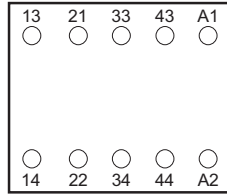

2 NO + 2 NC

22E

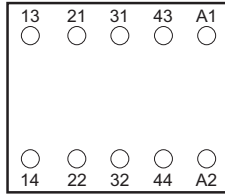

3RH11 40 contactor relays
with 3RH19 11-1GA... 3RH12 44, 3RH12 62
auxiliary switch blocks snapped onto the front

8 NO

Ident. No.: 80E

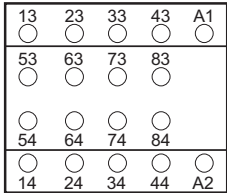

7 NO + 1 NC

71E

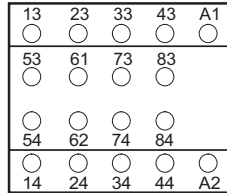

6 NO + 2 NC

62E

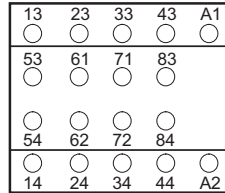

5 NO + 3 NC

53E

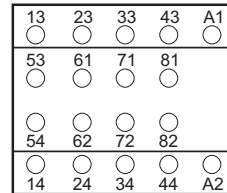

4 NO + 4 NC

Ident. No.: 44E

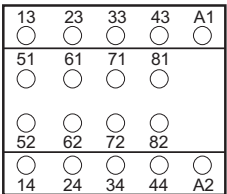

3RH14 latched contactor relays

4 NO

Ident. No.: 40E

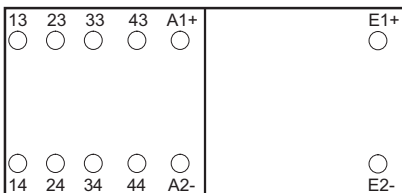

3 NO + 1 NC

31E

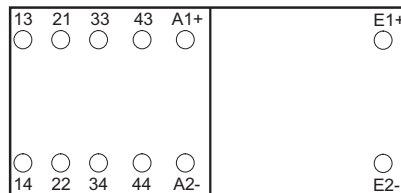

2 NO + 2 NC

Ident. No.: 22E

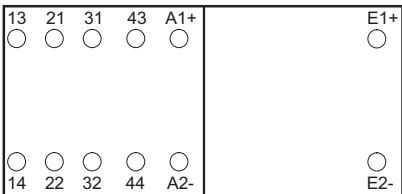

Project planning aids

Connection diagrams for 3RH11 coupling relays for switching auxiliary circuits

DC operation

L+ is to be connected to coil terminal A1.

3RH11 coupling relays for auxiliary circuits, size S00

Terminal designations according to EN 50011

(it is not possible to snap on an auxiliary switch block)

Surge suppressor can be mounted

4 NO

Ident. No.: 40E

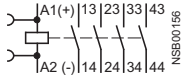

3 NO + 1 NC

31E

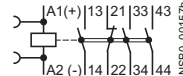

2 NO + 2 NC

22E

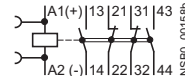

Diode integrated

4 NO

Ident. No.: 40E

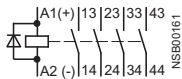

3 NO + 1 NC

31E

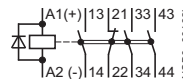

2 NO + 2 NC

22E

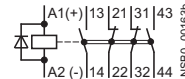

Varistor integrated

4 NO

Ident. No.: 40E

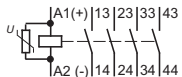

3 NO + 1 NC

31E

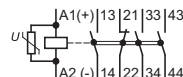

2 NO + 2 NC

22E

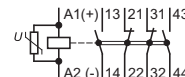

Surge suppressors for size S00 coupling relays

See 3RH11 contactor relays, page 3/232.

Position of the terminals for 3RH11 coupling relays for switching auxiliary circuits

Size S00

3RH11 coupling relays

4 NO

Ident. No.: 40E

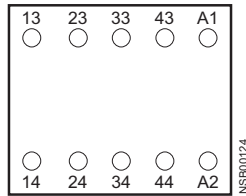

3 NO + 1 NC

31E

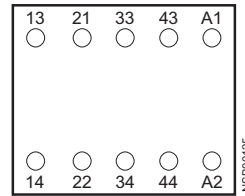

2 NO + 2 NC

22E

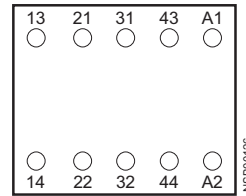

Circuit diagrams for 3RA13 reversing contactor assemblies

Size S00

Main circuit

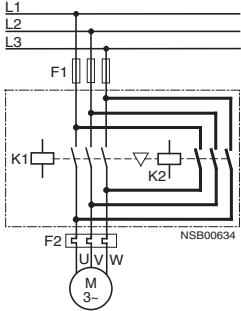

Control circuit

(The terminal designations for the contactors comply with EN 50012)

For momentary-contact operation

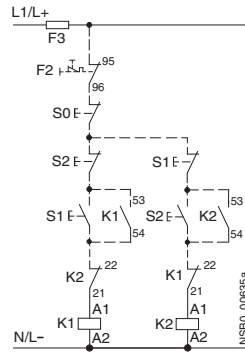

For maintained-contact operation

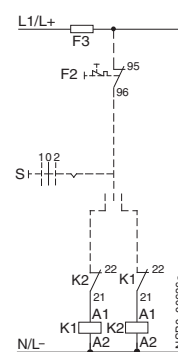

The 3RA19 13-2A assembly kit contains, among other things, wiring connectors for connecting the main circuit.

The 3RA19 13-2A assembly kit contains, among other things, the electrical interlock.

Sizes S0 to S3

Main circuit

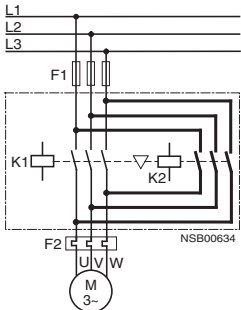

Control circuit

(The terminal designations for the contactors comply with EN 50005)

For momentary-contact operation

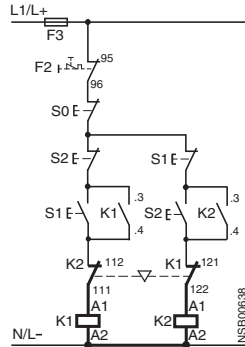

For maintained-contact operation

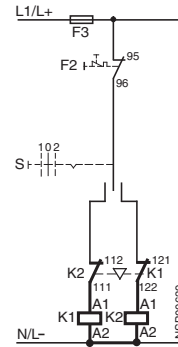

The 3RA19 .3-2A assembly kits contain, among other things, the wiring modules on the top and bottom for connecting the main current paths.

The 3RA19 24-2B mechanical interlock contains one NC contact for each contactor for the NC contact interlock.

Position of the terminals for 3RA13 reversing contactor assemblies

Size S0 to S3

Terminal designations according to EN 50005

3RA19 24-2B mechanical interlock (laterally mountable), integrated in reversing contactor assemblies (reversing starters), contains one NC contact for the electrical interlock for each contactor

2 NC

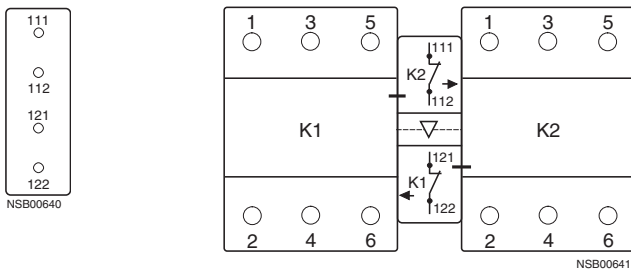

- S0 Button "OFF"
- S1 Button "Clockwise ON"
- S2 Button "Counterclockwise ON"
- S Button "CW-OFF-CCW"
- K1 Clockwise contactor
- K2 Counterclockwise contactor
- F1 Fuses for main circuit
- F3 Fuses for control circuit
- F2 Overload relays

Controls – Contactors and Contactor Assemblies

Project planning aids

Circuit diagrams for 3RA14 wye-delta starting contactor assemblies

Size S00 Main circuit

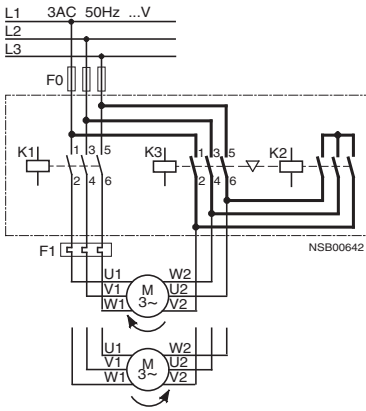

Control circuits with 3RT19 16-2G... solid state time-delay auxiliary switch block, snapped onto the front (example circuits)

For momentary-contact operation

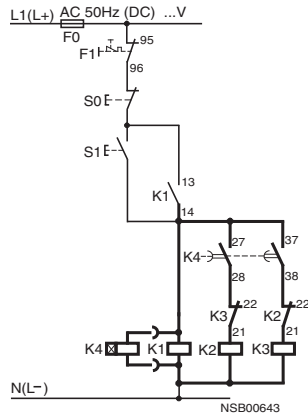

For maintained-contact operation

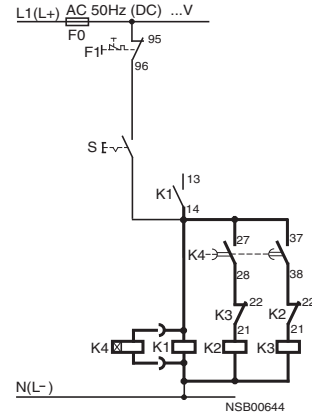

The contact element 27/28 for the solid-state time-delay auxiliary switch block with wye-delta function is only closed on the wye stage; the contact element is open in the delta stage as well as in the de-energized state.

Sizes S0 to S6¹⁾ Main circuit

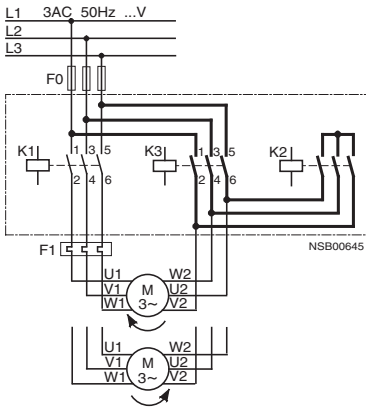

Control circuits with 3RP15 7. timing relay, laterally mounted (example circuits)

For momentary-contact operation

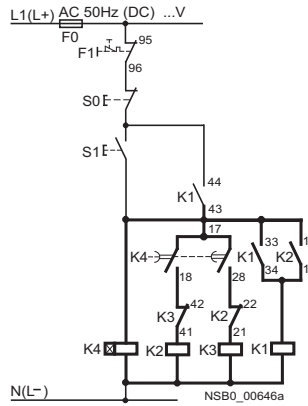

For maintained-contact operation

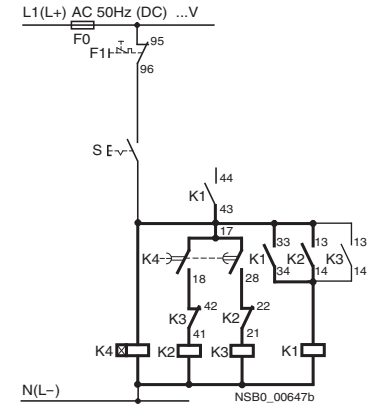

The contact element 17/18 is only closed in the wye stage; the contact element is open in the delta stage as well as in the de-energized state. S1 (S) is connected to clamping point K1/33.

Sizes S6 to S12

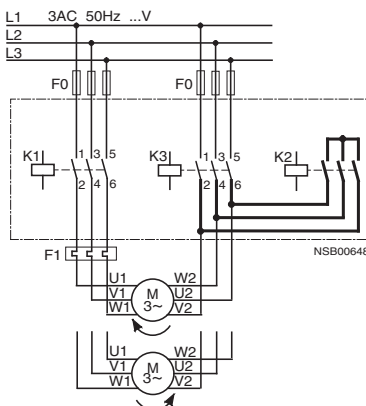

- S0 Button "OFF"
- S1 Button "ON"
- S Maintained-contact switch
- K1 Line contactor
- K2 Star contactor
- K3 Delta contactor
- K4 Solid-state, time-delay auxiliary switch block or timing relay
- F0 Fuses
- F1 Overload relays

¹⁾ Only 3RA19 53-2B assembly kit.

Internal circuit diagrams for 3TG10 miniature contactors

3TG10 10 contactors

1 NO
Ident. No.: 10E

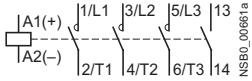

3TG10 01 contactors

1 NC
01E

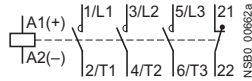

Internal circuit diagrams for 3TF68 and 3TF69 vacuum contactors, 3-pole

3TF68 44 and 3TF69 44 contactors

4 NO + 4 NC
AC operation
Maximum number of auxiliary contacts that can be fitted

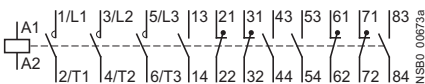

3TF68 33 and 3TF69 33 contactors

3 NO + 3 NC
DC operation
Maximum number of auxiliary contacts that can be fitted

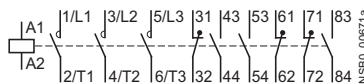

3TY7 681-1G
auxiliary switch blocks
for coil reconnection,
3TF68 and 3TF69,
DC economy circuit



3TY7 561-1AA00
auxiliary switch blocks
1st auxiliary switch block
left or right

Mounted on left Mounted on right



3TY7 561-1KA00
auxiliary switch blocks
2nd auxiliary switch block
left or right

Mounted on left Mounted on right



3TY7 561-1EA00
auxiliary switch blocks
with overlapping contacting

Mounted on left Mounted on right



3TY7 561-1. auxiliary switch blocks
Solid-state compatible auxiliary switch
block

Mounted on left Mounted on right



3TX7 090-0D
coupling links for control by PLC
with surge suppression

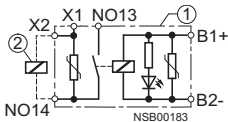

- ① Coupling link
- ② Contactor

Circuit diagrams for 3TF68 and 3TF69 vacuum contactors, 3-pole DC economy circuit · Maintained-contact operation

3TF68 33-.D.4 and 3TF69 33-.D.4 contactors

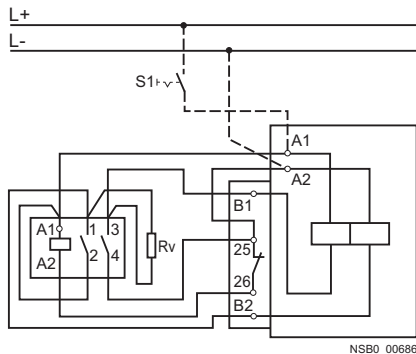

For AC control supply voltage subject to strong interference

3TF68 33-.Q.7 and 3TF69 33-.Q.7 contactors

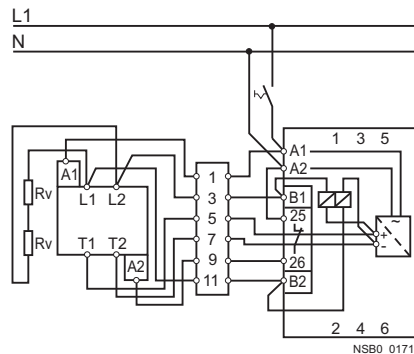

Controls – Contactors and Contactor Assemblies

Project planning aids

Internal circuit diagrams for 3TB50 to 3TB56 contactors, 3-pole

Sizes 6 to 12
3TB50 to 3TB56

DC operation
Auxiliary contacts: **2 NO + 2 NC**

Auxiliary switch block
3TY6 501-1E, 3TY6 561-1E

With overlapping
contacting

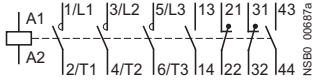

Circuit diagrams for 3TD68 reversing contactor assemblies

Main circuit

In the main circuit the connections are made between contactors K1 and K2.

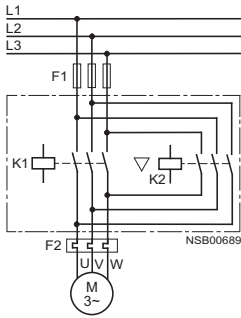

Control circuits

The control circuit cables indicated by broken lines are not wired in the factory.

Momentary-contact operation

Maintained-contact operation

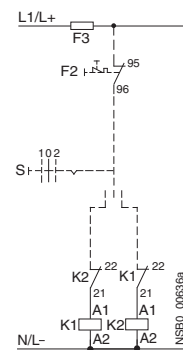
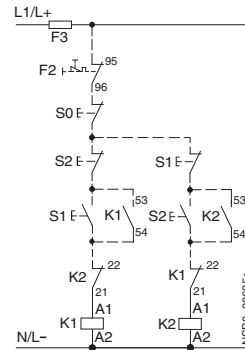

Terminal designations of the unassigned auxiliary contacts

Contactor assembly	With electrical interlock				Without electrical interlock			
	Contactor K1 NO contact	Contactor K1 NC contact	Contactor K2 NO contact	Contactor K2 NC contact	Contactor K1 NO contact	Contactor K1 NC contact	Contactor K2 NO contact	Contactor K2 NC contact
3TD68	13 - 14	21 - 22	13 - 14	31 - 32	13 - 14	21 - 22	13 - 14	21 - 22
	43 - 44	61 - 62	43 - 44	61 - 62	43 - 44	31 - 32	43 - 44	31 - 32
	53 - 54	71 - 72	53 - 54	71 - 72	53 - 54	61 - 62	53 - 54	61 - 62
	83 - 84		83 - 84		83 - 84	71 - 72	83 - 84	71 - 72

- S0 Button "OFF"
- S1 Button "Clockwise ON"
- S2 Button "Counterclockwise ON"
- S Button "CW-OFF-CCW"
- K1 Clockwise contactor
- K2 Counterclockwise contactor
- F1 Fuses for main circuit
- F3 Fuses for control circuit
- F2 Overload relays

Circuit diagrams for 3TE68 wye-delta starting contactor assemblies

Main circuit

Single infeed

Without main conducting path connection between line and delta contactors

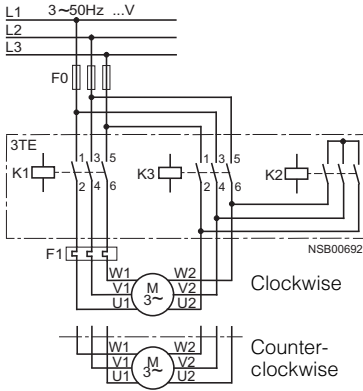

Double infeed

Without main conducting path connection between line and delta contactors

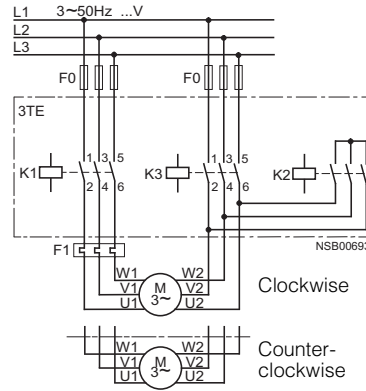

Control circuit with 3RP1 574 timing relay

For momentary-contact operation

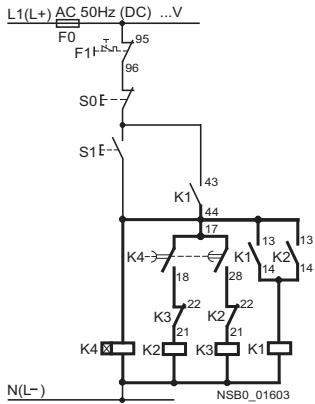

For maintained-contact operation

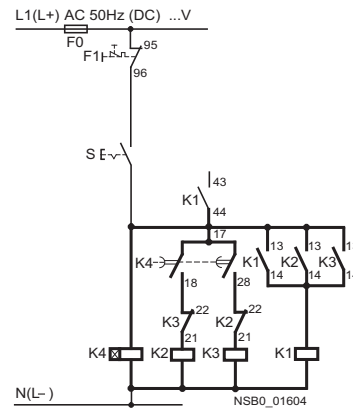

The contact element 17/18 is only closed in the wye stage; the contact element is open in the delta stage as well as in the de-energized state.

- S0 Button "OFF"
- S1 Button "ON"
- S Maintained-contact switch
- K1 Line contactor
- K2 Star contactor
- K3 Delta contactor
- K4 Timing relay
- F0 Fuses
- F1 Overload relays

Internal circuit diagrams for 3TK1 contactors, 4-pole (4 NO) for switching resistive loads (AC-1)

3TK1 contactors

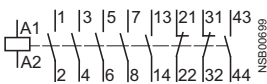

3TK1 910-3B
auxiliary switch block
Mounted on left



Mounted on right



Controls – Contactors and Contactor Assemblies

Project planning aids

Internal circuit diagram for 3TC44 to 3TC56 contactors for switching DC voltage

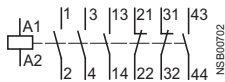

Internal circuit diagrams for 3TC74, 3TC78 contactors for switching DC voltage

DC operation

3TC74 contactors

Auxiliary contacts **4 NO + 4 NC**

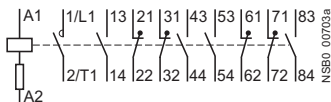

3TC78 contactors

Auxiliary contacts **4 NO + 4 NC**

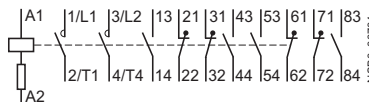

AC operation

Auxiliary contacts **4 NO + 4 NC**

Must be operated in the DC circuit

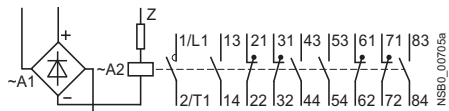

Auxiliary contacts **4 NO + 4 NC**

Must be operated in the DC circuit

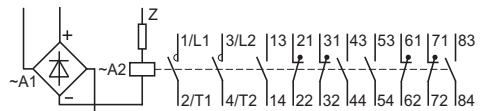

Circuit diagrams for 3TC74, 3TC78 contactors for switching DC voltage

3TC74 contactors

Momentary-contact operation

DC operation

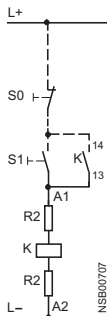

Maintained-contact operation

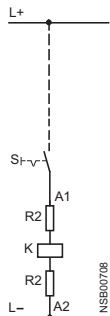

Momentary-contact operation

AC operation (must be operated in the DC circuit)

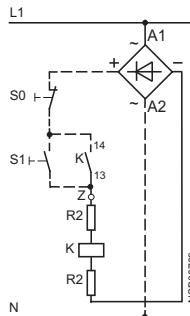

Maintained-contact operation

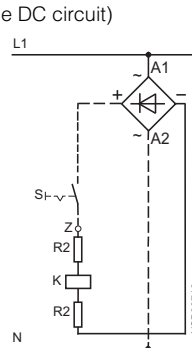

3TC78 contactors

Momentary-contact operation

DC operation

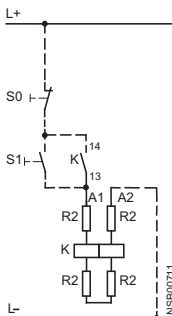

Maintained-contact operation

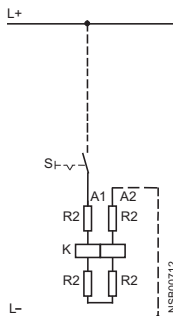

Momentary-contact operation

AC operation (must be operated in the DC circuit)

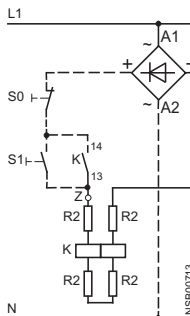

Maintained-contact operation

AC operation (must be operated in the DC circuit)

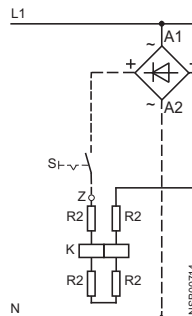

Circuit diagrams for 3T contactors with extended operating range 0.7 to 1.25 x U_s

Circuit with series resistor R_v (size 2 or larger) without reversing contactor

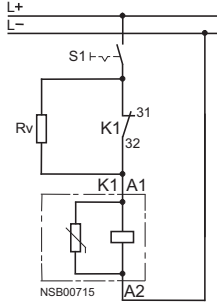

Circuit with series resistor R_v and reversing contactor K2 (for K1 contactors size 8 or larger)

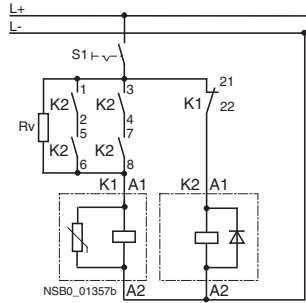

R_v:
Two resistors are connected in series for 3TB54, 3TB56 and 3TC56 contactors.

K2:
For 3TB52 to 3TB56 and 3TC52 to 3TC56:
3RT13 17-1F . 40

Position of the terminals for 3TG10 miniature contactors

3TG10 10 contactors

1 NO

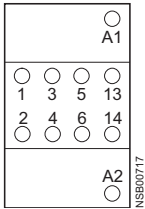

3TG10 01 contactors

1 NC

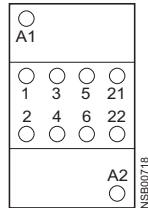

Position of the terminals for 3TF68 and 3TF69 vacuum contactors, 3-pole

AC operation

3TF68 and 3TF69 contactors

4 NO + 4 NC

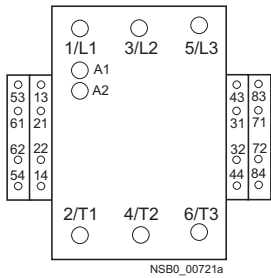

DC operation

3TF68 and 3TF69 contactors

3 NO + 3 NC

Maximum number of auxiliary contacts that can be fitted

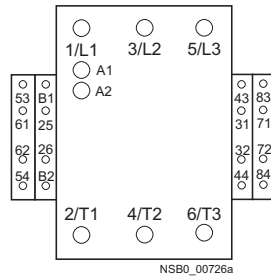

3TY7 561-1 . solid-state compatible auxiliary switch blocks for lateral mounting

Left mounted Right mounted

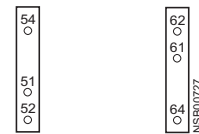

Controls – Contactors and Contactor Assemblies

Project planning aids

Position of the terminals for 3TB50 to 3TB56 contactors, 3-pole

Size 6 to 12
3TB50 to 3TB56 contactors

2 NO + 2 NC

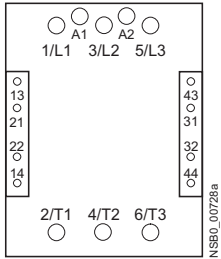

Position of the terminals for 3TK1 contactors for switching resistive loads (AC-1)

3TK10 to 3TK17 contactors

2 NO + 2 NC

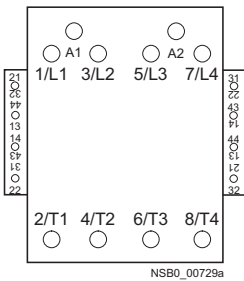

Position of the terminals for 3TC contactors for switching DC voltage

AC and DC operation

Size 2
3TC44 contactors

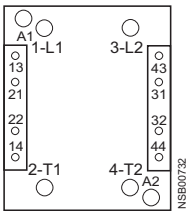

Sizes 4, 8 and 12
3TC48 to 3TC56 contactors

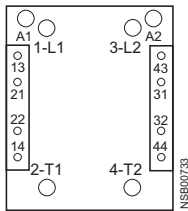

DC operation
3TC74 contactors

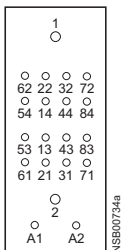

AC operation
3TC74 contactors

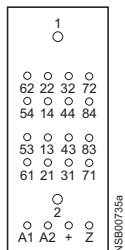

DC operation
3TC78 contactors

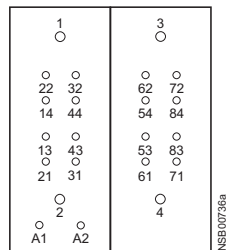

AC operation
3TC78 contactors

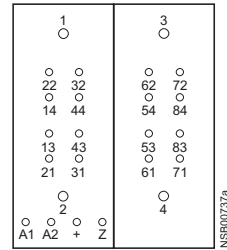

Internal circuit diagrams for 3TF2 and 3TK2 contactors

Terminal designations according to EN 50012

3TF20 ...-0 and 3TF28 ...-0 contactors with AC and DC operation

1 NO

Ident. No.: 10E

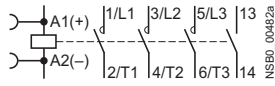

1 NC

01E

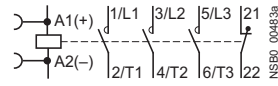

3TF20 ...-3, 3TF20 ...-6 and 3TF20 ...-7 contactors with AC and DC operation

1 NO

Ident. No.: 10E

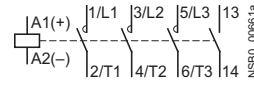

1 NC

01E

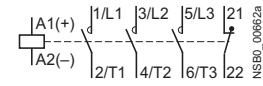

3TF20 10 contactors with 3TX4 4 ...-1 auxiliary switch block, 3TF22 and 3TF29 contactors with AC and DC operation

1 NO + 1 NC

Ident. No.: 11E

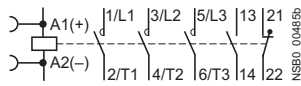

2 NO + 2 NC

22E

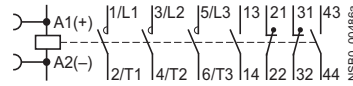

2 NO + 3 NC

Ident. No.: 23E

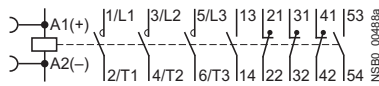

3 NO + 2 NC

32E

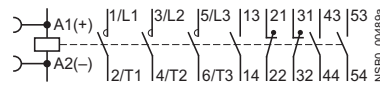

Terminal designations according to EN 50005

3TX4 4 ...-2 auxiliary switch block

4 NO

Ident. No.: 40

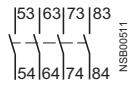

3 NO + 1 NC

31

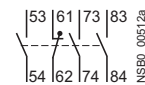

2 NO + 2 NC

22

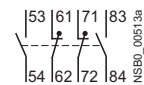

2 NO + 2 NC

22U

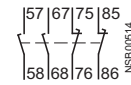

with make-before-break

2 NO

Ident. No.: 20



1 NO + 1 NC

11



2 NC

02



1 NO + 1 NC

11U



with make-before-break

3TK20 contactors

4 NO

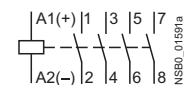

3 NO + 1 NC

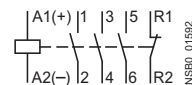

2 NO + 2 NC

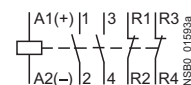

Surge suppressors

Diode



Diode assembly



Varistor



RC element



Diode with LED



Varistor with LED



Project planning aids

Internal circuit diagrams for 3TH2 contactor relays and 3TH27 latched contactor relays

Size S00

Terminal designations according to EN 50011

3TH20 ...0 contactor relays,
AC and DC operation,
with screw terminals

4 NO

Ident. No.: 40E

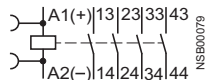

3 NO + 1 NC

31E

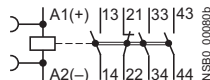

2 NO + 2 NC

22E

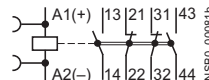

3TH20 ...-3, 3TH20 ...-6, 3TH20 ...-7 contactor relays,
AC and DC operation,
with flat connectors 6.3 mm x 0.8 mm and solder pin connections

4 NO

Ident. No.: 40E

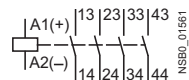

3 NO + 1 NC

31E

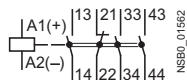

2 NO + 2 NC

22E

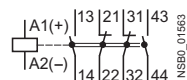

3TH20 40 contactor relays with 3TX4 4 ...0 auxiliary switch block and 3TH22 contactor relay

8 NO

Ident. No.: 80E

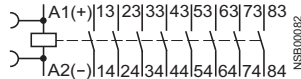

7 NO + 1 NC

71E

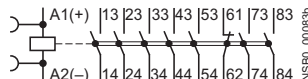

6 NO + 2 NC

62E

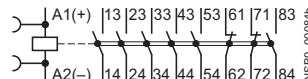

5 NO + 3 NC

Ident. No.: 53E



4 NO + 4 NC

44E

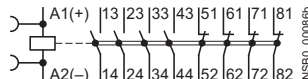

3TH27 latched contactor relays,
AC and DC operation

4 NO

Ident. No.: 40E

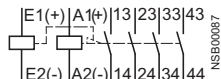

3 NO + 1 NC

31E

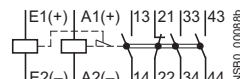

2 NO + 2 NC

22E

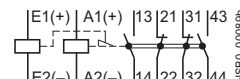

Terminal designations according to EN 50005

3TX4 4 ...2 auxiliary switch block

Positively-driven operation is assured likewise for auxiliary switch blocks according to EN 50005 in conjunction with 3TH20 contactor relays (basic units).

4 NO

Ident. No.: 40

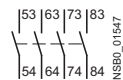

3 NO + 1 NC

31

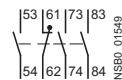

2 NO + 2 NC

22

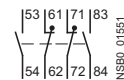

2 NO + 2 NC

22U

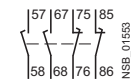

with make-before-break

2 NO

Ident. No.: 20



1 NO + 1 NC

11



2 NC

02



1 NO + 1 NC

11U



with make-before-break

Surge suppressors

Diode



Diode assembly



Varistor



RC element



Diode with LED



Varistor with LED

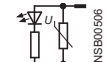

Relay couplers – connection diagrams for 3TX7 002/3TX7 003

Terminal designations according to EN 50005

3TX7 002-.A.00
3TX7 002-1AB02
3TX7 002-2AF05
3TX7 003-.A.00

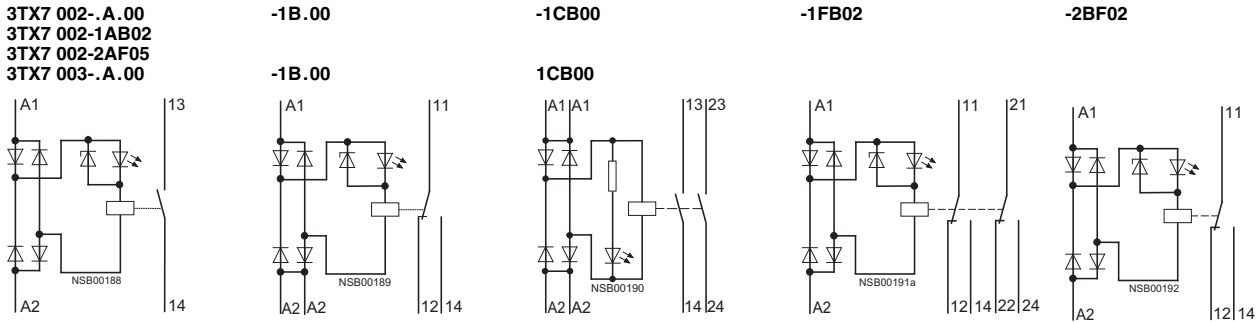

Relay couplers – position of the terminals

Output coupling links

3TX7 002-1AB0.
3TX7 003-1AB00

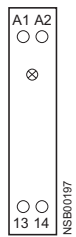

-1B.00
-1B.00

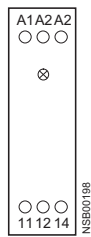

-1CB00
-1CB00

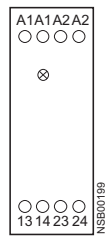

-1FB02

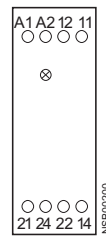

Input coupling links

3TX7 002-2A.0.
3TX7 003-2A.0.



-2BF02

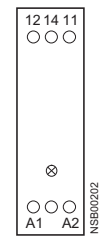

Relay couplers – connection diagrams for 3TX7 004/3TX7 005

Output coupling links

3TX7 00.-1M.00

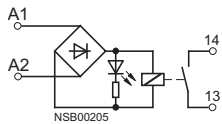

3TX7 00.-1AB10

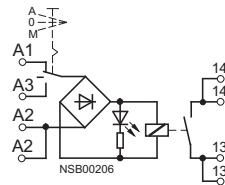

3TX7 00.-1BB00
3TX7 00.-1BF05

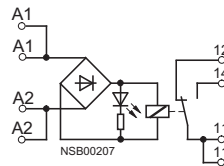

3TX7 00.-1L.0.

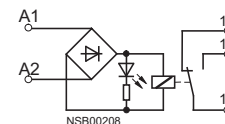

3TX7 00.-1BB10

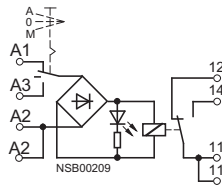

A = Automatic
0 = Neutral position
M = Manual

Input coupling links

3TX7 00.-2M.02

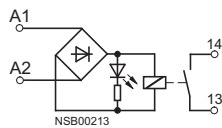

Controls – Contactors and Contactor Assemblies

Project planning aids

Relay couplers – position of the terminals

Output coupling links

3TX7 004
-1M.00



-1L.0.



-1AB10

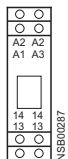

-1B.0.

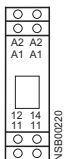

-1BB10

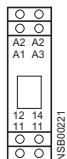

-1CB00



-1HB00

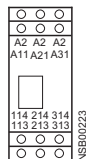

-1GB00

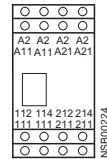

Input coupling links
3TX7 004-2M...

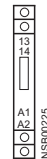

3TX7 005
-1M.00



-1L.0.



-1AB10

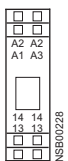

-1BB00

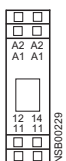

-1BB10



-1CB00

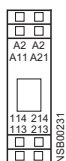

-1HB00



-1GB00

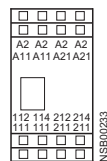

3TX7 005-2M...

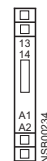

Semiconductor couplers – connection diagrams

Terminal designations according to EN 50005

3TX7 002-3AB00

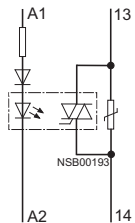

-3AB01

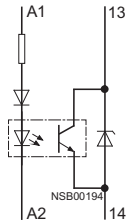

-4AB00

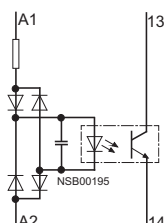

-4AG00

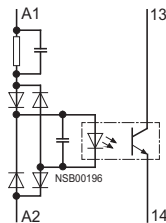

Semiconductor couplers – position of the terminals

Output coupling links

3TX7 002-3AB0.

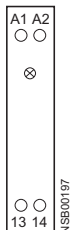

Input coupling links

3TX7 002-4A.0.

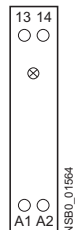

Semiconductor couplers – connection diagrams

Output coupling links

3TX7 00.-3AB04
3TX7 00.-3PB41

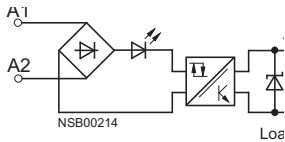

3TX7 00.-3PB54
3TX7 00.-3PG74
3TX7 00.-3PB74

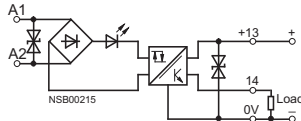

3TX7 00.-3AC04

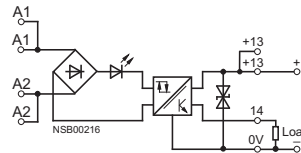

3TX7 00.-3AC14

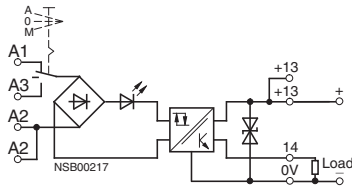

3TX7 00.-3AC03

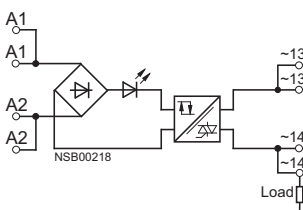

Input coupling links

3TX7 00.-4AB04

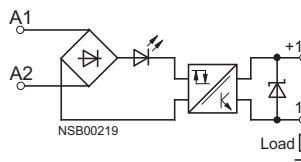

A = Automatic
0 = Neutral position
M = Manual

Semiconductor couplers – position of the terminals

Output coupling links

3TX7 004
-3AB04,
-3PB41



-3PB54,
-3PB74,
-3PG74



-3AC04

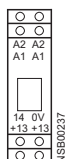

-3AC14

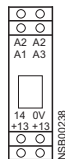

-3AC03

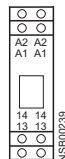

Input coupling links

3TX7 004-4AB04



3TX7 005
-3AB04,
-3PB41



-3PB54,
-3PB74,
-3PG74

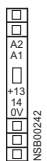

-3AC04

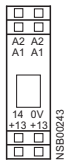

-3AC14

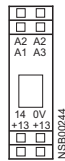

-3AC03

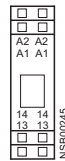

3TX7 005-4AB04

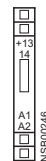

3RS18 coupling relays with industrial housing – position of the terminals

3RS18 00
-.AP00
-.AQ00



3RS18 00
-.BP00
-.BQ00

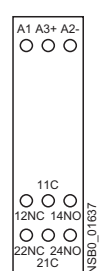

3RS18 00
-.HP0.
-.HQ0.



3RS18 00
-.BW00

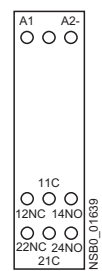

3RS18 00
-.HW0.

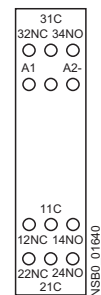

Controls – Contactors and Contactor Assemblies

Project planning aids

LZX plug-in relays – relay couplers

LZX:PT270
2-pole

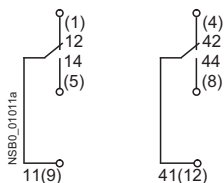

LZX:PT370
3-pole

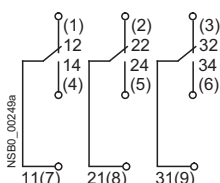

LZX:PT520, LZX:PT570, LZX:PT580
4-pole

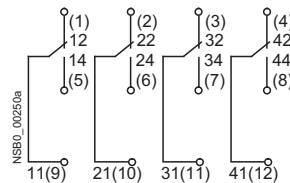

LZX:RT3
1-pole

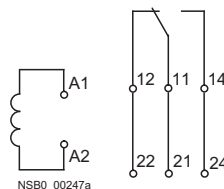

LZX:RT4
2-pole

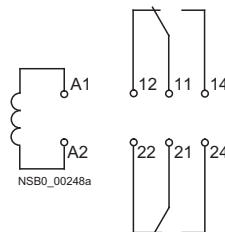

LZX:MT32
3-pole

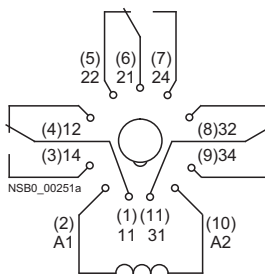

Values in brackets: socket designations.
Without brackets: contact/coil designations.

Position of the connection terminals

Standard plug-in bases for PT series

LZS:PT78720

for 2 CO contacts, with screw terminals

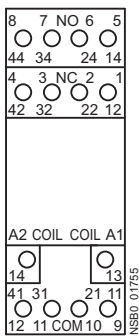

LZS:PT78730

for 3 CO contacts, with screw terminals

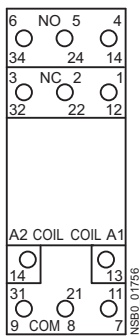

LZS:PT78740

for 4 CO contacts, with screw terminals

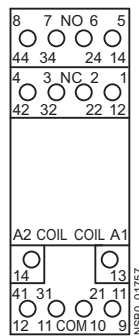

Plug-in bases with logical isolation for PT series

LZS:PT78722
for 2 CO contacts,
with screw terminals

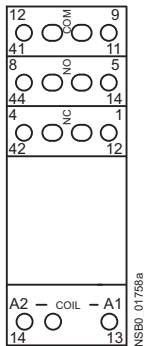

LZS:PT78742
for 4 CO contacts,
with screw terminals

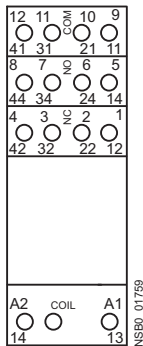

LZS:PT7872P
for 2 CO contacts,
with spring-type terminals

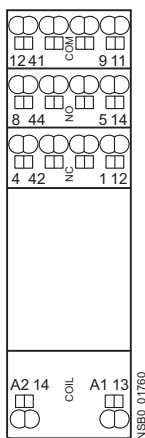

LZS:PT7874P
for 4 CO contacts,
with spring-type terminals

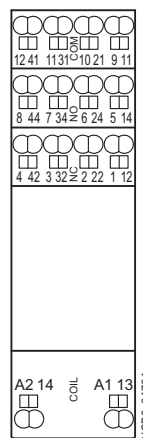

Plug-in bases for RT series

LZS:RT78725
with screw terminals



LZS:RT78726
with logical isolation and
screw terminals

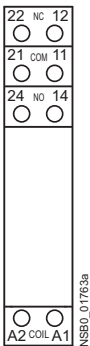

LZS:RT7872P
with logical isolation and spring-type
terminals



Plug-in bases for MT series

LZS:MT78750
for industrial relays

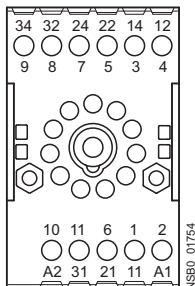

Controls – Contactors and Contactor Assemblies

Notes

3

Controls – Solid-State Switching Devices

4



4/2	Introduction
4/3	Solid-State Switching Devices General data
4/4	Solid-State Switching Devices for Resistive Loads General data <u>Solid-State Relays</u>
4/6	General data
4/7	3RF21 solid-state relays, single-phase, 22.5 mm
4/13	3RF20 solid-state relays, single-phase, 45 mm
4/17	3RF22 solid-state relays, three-phase, 45 mm <u>Solid-State Contactors</u>
4/23	General data
4/24	3RF23 solid-state contactors, single-phase
4/33	3RF24 solid-state contactors, three-phase <u>3RF29 Function Modules</u>
4/42	General data
4/44	Converters
4/45	Load monitoring
4/46	Heating current monitoring
4/47	Power controllers
4/48	Power regulators
4/49	Project planning aids
4/51	Solid-State Switching Devices for Switching Motors <u>Solid-State Contactors</u> General data
4/53	3RF24 solid-state contactors, three-phase
4/59	3RF24 solid-state reversing contactors, three-phase

Controls – Solid-State Switching Devices

Introduction

Overview



		Order No.	Page
SIRIUS solid-state switching devices for switching resistive loads			
<i>Solid-state relays</i>			
22.5 mm solid-state relays, 45 mm solid-state relays	<ul style="list-style-type: none"> • Widths of 22.5 mm and 45 mm • Compact and space-saving design • "Zero-point switching" version • Mounting onto existing heat sinks 	3RF21, 3RF20 3RF22	4/7 4/13 4/17
<i>Solid-state contactors</i>			
Solid-state contactors	<ul style="list-style-type: none"> • Complete units comprising a solid-state relay and an optimized heat sink, "ready to use" • Compact and space-saving design • Versions for resistive loads "zero-point switching" and inductive loads "instantaneous switching" • Special versions "Low noise" and "Short-circuit resistant" 	3RF23 3RF24	4/24 4/33
<i>Function modules</i>			
	For extending the functionality of the 3RF21 solid-state relays and the 3RF23 solid-state contactors for many different applications:		
Converters	<ul style="list-style-type: none"> • For converting an analog input signal into an on/off ratio; can also be used on 3RF22 and 3RF24 three-phase switching devices 	3RF29 00-0EA18	4/44
Load monitoring	<ul style="list-style-type: none"> • For load monitoring of one or more loads (partial loads) 	3RF29 20-0FA08, 3RF29 .0-0GA..	4/45
Heating current monitoring	<ul style="list-style-type: none"> • For load monitoring of one or more loads (partial loads); remote teach 	3RF29 ..-0JA..	4/46
Power controllers	<ul style="list-style-type: none"> • For supplying the current by means of a solid-state switching device depending on a setpoint value. There is a choice of full-wave control and generalized phase control. 	3RF29 ..-0KA.	4/47
Power regulators	<ul style="list-style-type: none"> • For supplying the current by means of a solid-state switching device depending on a setpoint value. Closed-loop control: full-wave control or generalized phase control 	3RF29 .0-0HA..	4/48
SIRIUS solid-state switching devices for switching motors			
<i>Solid-state contactors</i>			
Solid-state contactors, solid-state reversing contactors	<ul style="list-style-type: none"> • Complete units comprising in the insulated enclosure with integrated heat sink, "ready to use" • Compact and space-saving design • Version for motors, "instantaneous switching" 	3RF24	4/53

Overview

**SIRIUS 3RF2 solid-state switching devices**

The 3RF solid-state switching devices reliably switch a wide range of different loads with alternating voltages in 50 and 60 Hz systems.

Solid-state switching devices for resistive loads

- Solid-state relays
- Solid-state contactors
- Function modules

Solid-state switching devices for switching motors

- Solid-state contactors
- Solid-state reversing contactors

SIRIUS 3RF2 – for almost unending activity

Conventional electromechanical controlgear is often overtaxed by the rise in the number of switching operations. A high switching frequency results in frequent failure and short replacement cycles. However, this does not have to be the case, because with the latest generation of our SIRIUS 3RF2 solid-state switching devices we provide you with solid-state relays and contactors with a particularly long endurance – for almost unending activity even under the toughest conditions and under high mechanical load, but also in noise-sensitive areas.

Proved time and again in service

SIRIUS 3RF2 solid-state switching devices have firmly established in industrial applications. They are used above all in applications where loads are switched frequently – mainly with resistive load controllers, with the control of electrical heat or the control of valves and motors in conveyor systems. In addition to its use in areas with high switching frequencies, their silent switching means that SIRIUS is also ideally suited for use in noise-sensitive areas, such as offices or hospitals.

The most reliable solution for any application

Compared to mechanical controlgear, our SIRIUS 3RF2 solid-state switching devices stand out due to their considerably longer service life. Thanks to the high product quality, their switching is extremely precise, reliable and, above all, unsusceptible to faults. With its variable connection methods and a wide spread of control voltages, the SIRIUS 3RF2 family is universally applicable. Depending on the individual requirements of the application, our modular controlgear can also be quite easily expanded by the addition of standardized function modules.

Also for switching motors

In order to achieve higher productivity, the switching frequency is continuously increased. It is no problem for our SIRIUS solid-state contactors to switch motors. With induction motors up to 7.5 kW, they can reliably withstand even the highest switching frequencies. Even a continuous change in the direction of rotation is possible with the solid-state reversing contactors. Both versions can be perfectly combined with components from the SIRIUS modular system. Connecting with SIRIUS motor starter protectors or SIRIUS overload relay can be implemented without any further steps.



Always on the sunny side with SIRIUS

Because SIRIUS 3RF2 offers even more:

- The space-saving and compact side-by-side mounting ensures reliable operation up to an ambient temperature of +60 °C.
- Thanks to fast configuration and the ease of mounting and start-up, you save not only time but also expenses.

Connection methods

The devices are available with screw terminals (box terminals), spring-type terminals or ring terminal lugs.

-  Screw terminals
-  Spring-type terminals
-  Ring terminal lug connections

These connections are indicated in the Technical specifications by orange backgrounds.

Solid-State Switching Devices for Resistive Loads

General data

Overview

Type	Solid-state relays			Solid-state contactors		Function modules					
	Single-phase		Three-phase 45 mm	Single-phase	Three-phase	Converters	Load monitoring		Heating current monitoring	Power controllers	Power regulators
	22.5 mm	45 mm					Basic	Extended			
Usage											
Simple use of existing solid-state relays	<input type="checkbox"/>	<input checked="" type="checkbox"/>	<input type="checkbox"/>	<input type="checkbox"/>	<input type="checkbox"/>	--	--	--	--	--	--
Complete unit "Ready to use"	<input type="checkbox"/>	<input type="checkbox"/>	<input type="checkbox"/>	<input checked="" type="checkbox"/>	<input checked="" type="checkbox"/>	--	--	--	--	--	--
Space-saving	<input checked="" type="checkbox"/>	--	<input checked="" type="checkbox"/>	<input checked="" type="checkbox"/>	<input checked="" type="checkbox"/>	<input checked="" type="checkbox"/>	<input checked="" type="checkbox"/>	--	--	--	--
Can be extended with modular function modules	<input checked="" type="checkbox"/>	--	1)	<input checked="" type="checkbox"/>	1)	--	--	--	--	--	--
Frequent switching and monitoring of loads and solid-state relays/solid-state contactors	--	--	--	--	--	--	<input checked="" type="checkbox"/>	<input checked="" type="checkbox"/>	<input checked="" type="checkbox"/>	<input checked="" type="checkbox"/>	<input checked="" type="checkbox"/>
Monitoring of up to 6 partial loads	--	--	--	--	--	--	<input checked="" type="checkbox"/>	--	<input checked="" type="checkbox"/>	<input checked="" type="checkbox"/>	--
Monitoring of more than 6 partial loads	--	--	--	--	--	--	--	<input checked="" type="checkbox"/>	--	--	--
Control of the heating power through an analog input	--	--	--	--	--	<input checked="" type="checkbox"/>	--	--	--	<input checked="" type="checkbox"/>	<input checked="" type="checkbox"/>
Power control	--	--	--	--	--	--	--	--	--	--	<input checked="" type="checkbox"/>
Startup											
Easy setting of setpoint values with "Teach" button	--	--	--	--	--	--	<input checked="" type="checkbox"/>	<input checked="" type="checkbox"/>	--	<input checked="" type="checkbox"/>	<input checked="" type="checkbox"/>
"Remote Teach" input for setting setpoints	--	--	--	--	--	--	--	--	<input checked="" type="checkbox"/>	--	--
Mounting											
Mounting onto mounting rails or mounting plates	--	--	--	<input checked="" type="checkbox"/>	<input checked="" type="checkbox"/>	--	--	--	--	--	--
Can be snapped directly onto a solid-state relay or contactor	--	--	--	--	--	<input checked="" type="checkbox"/>	<input checked="" type="checkbox"/>	<input checked="" type="checkbox"/>	<input checked="" type="checkbox"/>	<input checked="" type="checkbox"/>	<input checked="" type="checkbox"/>
For use with "Cool-plate" heat sink	<input checked="" type="checkbox"/>	<input checked="" type="checkbox"/>	<input checked="" type="checkbox"/>	--	--	--	--	--	--	--	--
Cable routing											
Connection of load circuit as for controlgear	<input checked="" type="checkbox"/>	--	<input checked="" type="checkbox"/>	<input checked="" type="checkbox"/>	<input checked="" type="checkbox"/>	--	<input checked="" type="checkbox"/>	<input checked="" type="checkbox"/>	<input checked="" type="checkbox"/>	<input checked="" type="checkbox"/>	<input checked="" type="checkbox"/>
Connection of load circuit from above	--	<input checked="" type="checkbox"/>	--	--	--	--	--	--	--	--	--

Function is available

Function is possible

1) The converter can also be used with three-phase devices.

Design

There is no typical design of a load feeder with solid-state relays or solid-state contactors; instead, the great variety of connection methods and control voltages offers universal application opportunities. SIRIUS solid-state relays and solid-state contactors can be installed in fuseless or fused feeders, as required. There are special versions with which it is even possible to achieve short-circuit strength in a fuseless design.

Connection methods

All SIRIUS solid-state switching devices are characterized by the great variance of connection methods. You can choose between the following connection methods:

Screw connection

The screw connection system is the standard among industrial controls. Open terminals and a plus-minus screw are just two features of this technology. Two conductors of up to 6 mm² can be connected in just one terminal. As a result, loads of up to 50 A can be connected.

Spring-type terminal connection system

This innovative technology manages without any screw connection. This means that very high vibration resistance is achieved. Two conductors of up to 2.5 mm² can be connected to each terminal. As a result, loads of up to 20 A can be dealt with.

Ring terminal lug connection

The ring terminal lug connection is equipped with an M5 screw. Ring terminal lugs of up to 25 mm² can be connected. In this way it is possible to connect even high powers with current strengths of up to 90 A safely. Finger-safety is provided in this case too with a special cover.

Function

Switching functions

In order to guarantee an optimized control method for different loads, the functionality of our solid-state switching devices can be adapted accordingly.

The "zero-point switching" method has proved to be ideal for resistive loads, i. e. where the power semiconductor is activated at zero voltage.

For inductive loads, on the other hand, for example in the case of valves, it is better to go with "instantaneous switching". By distributing the ON point over the entire sine curve of the mains voltage, disturbances are reduced to a minimum.

Performance characteristics

The performance of the solid-state switching devices is substantially determined by the type of power semiconductors used and the internal design. In the case of the SIRIUS solid-state contactors and solid-state relays, only thyristors are used in place of less powerful Triacs.

Two of the most important features of thyristors are the blocking voltage and the maximum load integral:

Blocking voltage

Thyristors with a high blocking voltage can also be operated without difficulty in networks with high interference voltages. Separate protective measures, such as a protective circuit with a varistor, are not necessary in most cases.

For example, thyristors with 800 V blocking voltage are fitted in the devices for operation in networks up to 230 V. Thyristors with up to 1600 V are used for power systems with higher voltages.

Maximum load integral

One of the purposes of specifying the maximum load integral (Pt) is to determine the rating of the short-circuit protection. Only a large power semiconductor with a correspondingly high Pt value can be given appropriate protection against destruction from a short-circuit by means of a protective device matched to the application. However, the devices are also characterized by the optimum matching of the thyristors (Pt value) with the rated currents. The rated currents specified on the devices according to EN 60947-4-3 were confirmed by extensive testing.

You can find more information on the Internet at:

http://www.siemens.com/cd/is_schalten/html_76/schalt.htm

Integration

Notes on integration in the load feeders

The SIRIUS solid-state switching devices are very easy to integrate into the load feeders thanks to their industrial connection method and design.

Particular attention must however be paid to the circumstances of the installation and ambient conditions, as the performance of the solid-state switching devices is largely dependent on these. Depending on the version, certain restrictions must be observed. Detailed information, for example in relation to solid-state contactors about the minimum spacing and to solid-state relays about the choice of heat sink, is given in the technical specifications and the product data sheets.

Despite the rugged power semiconductors that are used, solid-state switching devices respond more sensitively to short-circuits in the load feeder. Consequently, special precautions have to be taken against destruction, depending on the type of design.

Siemens generally recommends using SITOP semiconductor protection fuses. These fuses also provide protection against destruction in the event of a short-circuit even when the solid-state contactors and solid-state relays are fully utilized.

Alternatively, if there is lower loading, protection can also be provided by standard fuses or miniature circuit breakers. This protection is achieved by overdimensioning the solid-state switching devices accordingly. The technical specifications and the product data sheets contain details both about the solid-state fuse protection itself and about use of the devices with conventional protection equipment.

The solid-state switching devices for resistive loads are suitable for interference-free operation in industrial networks without further measures. If they are used in public networks, it may be necessary for conducted interference to be reduced by means of filters. This does not include the special solid-state contactors of type 3RF23...-CA.. "Low Noise". These comply with the class B limit values up to a rated current of 16 A. If other versions are used, and at currents of over 16 A, standard filters can be used in order to comply with the limit values. The decisive factors when it comes to selecting the filters are essentially the current loading and the other parameters (operational voltage, design type, etc.) in the load feeder.

Suitable filters can be ordered from EPCOS AG.

You can find more information on the Internet at:

<http://www.epcos.com>

Solid-State Switching Devices for Resistive Loads

Solid-State Relays

General data

Overview

Solid-state relays

SIRIUS solid-state relays are suitable for surface mounting on existing cooling surfaces. Mounting is quick and easy, involving just two screws. The special technology of the power semiconductor ensures there is excellent thermal contact with the heat sink. Depending on the nature of the cooler, the capacity reaches up to 88 A on resistive loads.

The solid-state relays are available in three different versions:

- 3RF21 single-phase solid-state relays with a width of 22.5 mm
- 3RF20 single-phase solid-state relays with a width of 45 mm
- 3RF22 three-phase solid-state relays with a width of 45 mm.

The 3RF21 and 3RF22 solid-state relays can be expanded with various function modules to adapt them to individual applications.

Version for resistive loads, "zero-point switching"

This standard version is often used for switching space heaters on and off.

Version for inductive loads, "instantaneous switching"

In this version the solid-state relay is specifically matched to inductive loads. Whether it is a matter of frequent actuation of the valves in a filling plant or starting and stopping small operating mechanisms in packet distribution systems, operation is carried out safely and noiselessly.

Single-phase solid-state relay with a width of 22.5 mm

With its compact design, which stays the same even at currents of up to 88 A, the 3RF21 solid-state relay is the ultimate in space-saving construction, at a width of 22.5 mm. The logical connection method, with the power infeed from above and load connection from below, ensures tidy installation in the control cabinet.

Single-phase solid-state relay with a width of 45 mm

The solid-state relays with a width of 45 mm provide for connection of the power supply lead and the load from above. This makes it easy to replace existing solid-state relays in existing arrangements. The connection of the control cable also saves space in much the same way as the 22.5 mm design, as it is simply plugged on.

Three-phase solid-state relay with a width of 45 mm

With its compact design, which stays the same even at currents of up to 55 A, the 3RF22 solid-state relay is the ultimate in space-saving construction, at a width of 45 mm. The logical connection method, with the power infeed from above and load connection from below, ensures tidy installation in the control cabinet.

The three-phase solid-state relays are available with

- two-phase control and
- three-phase control.

Function

Three-phase solid-state switching devices

Two-phase controlled version

A three-phase control system is not required for many three-phase current applications. Loads in a delta circuit or star circuit which have no connection to the neutral conductor can also be safely switched on and off using just two phases.

Nevertheless, the three-phase 3RF22 and 3RF24 solid-state switching devices permit all three phases to be connected to the switching device, in which case the middle phase is looped directly through the device. Compared to a three-phase controlled device, the lower power loss allows more compact installations.

Three-phase controlled version

This version is used for three-phase current applications in which the system requires all phases to be switched on and off, or for loads in a star circuit with connection to the neutral conductor.

Configuration

Selecting solid-state relays

When selecting solid-state relays, in addition to information about the network, the load and the ambient conditions it is also necessary to know details of the planned design. The solid-state relays can only conform to their specific technical specifications if they are mounted with appropriate care on an adequately dimensioned heat sink.

The following procedure is recommended:

- Determine the rated current of the load and the mains voltage
- Select the relay design and choose a solid-state relay with higher rated current than the load
- Determine the thermal resistance of the proposed heat sink
- Check the correct relay size with the aid of the diagrams

You can find more information on the Internet at:

http://www.siemens.com/cd/is_schalten/html_76/schalt.htm

Solid-State Switching Devices for Resistive Loads

Solid-State Relays



3RF21 solid-state relays, single-phase, 22.5 mm

Overview

22.5 mm solid-state relays

With its compact design, which stays the same even at currents of up to 88 A, the 3RF21 solid-state relay is the ultimate in space-saving construction, at a width of 22.5 mm. The logical connection method, with the power infeed from above and load connection from below, ensures tidy installation in the control cabinet.

Technical specifications

Type		3RF21 ..-1....	3RF21 ..-2....	3RF21 ..-3....
General data				
Ambient temperature				
• During operation, derating from 40 °C	°C	-25 ... + 60		
• During storage	°C	-55 ... + 80		
Installation altitude	m	0 ... 1000; derating from 1000		
Shock resistance acc. to IEC 60068-2-27	g/ms	15/11		
Vibration resistance acc. to IEC 60068-2-6	g	2		
Degree of protection		IP20		
Electromagnetic compatibility (EMC)				
• Emitted interference				
- Conducted interference voltage acc. to IEC 60947-4-3		Class A for industrial applications		
- Emitted, high-frequency interference voltage acc. to IEC 60947-4-3		Class A for industrial applications		
• Interference immunity				
- Electrostatic discharge acc. to IEC 61000-4-2 (corresponds to degree of severity 3)	kV	Contact discharge 4; air discharge 8; behavior criterion 2		
- Induced RF fields acc. to IEC 61000-4-6	MHz	0.15 ... 80; 140 dBµV; behavior criterion 1		
- Burst acc. to IEC 61000-4-4	kV	2/5.0 kHz; behavior criterion 1		
- Surge acc. to IEC 61000-4-5	kV	Conductor - ground 2; conductor - conductor 1; behavior criterion 2		
Connection type		 Screw terminals	 Spring-type terminals	 Ring terminal lug connections
Connection, main contacts				
• Conductor cross-section	mm ²	2 x (1.5 ... 2.5) ¹⁾ , 2 x (2.5 ... 6) ¹⁾	2 x (0.5 ... 2.5)	--
- Solid	mm ²	2 x (1 ... 2.5) ¹⁾ , 2 x (2.5 ... 6) ¹⁾	2 x (0.5 ... 1.5)	--
- Finely stranded with end sleeve	mm ²	1 x 10	--	--
- Finely stranded without end sleeve	mm ²	--	2 x (0.5 ... 2.5)	--
- Solid or stranded, AWG cables		2 x (AWG 14 ... 10)	2 x (AWG 18 ... 14)	--
• Terminal screw		M4	--	M5
• Tightening torque	Nm lb.in	2 ... 2.5 7 ... 10.3	--	2.5 ... 2 10.3 ... 7
• Cable lug		--	--	--
- DIN		--	--	DIN 46234 -5-2.5, -5-6, -5-10,
- JIS		--	--	-5-16, -5-25 JIS C 2805 R 2-5, 5.5-5, 8-5, 14-5
Connection, auxiliary/control contacts				
• Conductor cross-section	mm AWG	1 x (0.5 ... 2.5), 2 x (0.5 ... 1.0)	0.5 ... 2.5 20 ... 12	1 x (0.5 ... 2.5), 2 x (0.5 ... 1.0) 20 ... 12
• Stripped length	mm	7	10	7
• Terminal screw		M3	--	M3
• Tightening torque	Nm lb.in	0.5 ... 0.6 4.5 ... 5.3	--	0.5 ... 0.6 4.5 ... 5.3

¹⁾ If two different conductor cross-sections are connected to one clamping point, both cross-sections must lie in the range specified. If identical cross-sections are used, this restriction does not apply.

Solid-State Switching Devices for Resistive Loads

Solid-State Relays

3RF21 solid-state relays, single-phase, 22.5 mm

Order No.	$I_{\max}^{1)}$ at $R_{\text{thha}}/T_u = 40\text{ °C}$		I_e acc. to IEC 60947-4-3 at $R_{\text{thha}}/T_u = 40\text{ °C}$		I_e acc. to UL/CSA at $R_{\text{thha}}/T_u = 50\text{ °C}$		Power loss at I_{\max}	Minimum load current	Leakage current
	A	K/W	A	K/W	A	K/W			
Main circuit									
3RF21 20-.....	20	2.0	20	1.7	20	1.3	28.6	0.1	10
3RF21 30-1....	30	1.1	30	0.79	30	0.56	44.2	0.5	10
3RF21 50-1....	50	0.68	50	0.48	50	0.33	66	0.5	10
3RF21 50-2....	50	0.68	20	2.6	20	2.9	66	0.5	10
3RF21 50-3....	50	0.68	50	0.48	50	0.33	66	0.5	10
3RF21 70-1....	70	0.40	50	0.77	50	0.6	94	0.5	10
3RF21 90-1....	88	0.33	50	0.94	50	0.85	118	0.5	10
3RF21 90-2....	88	0.33	20	2.8	20	3.5	118	0.5	10
3RF21 90-3....	88	0.33	88	0.22	83	0.19	118	0.5	10

¹⁾ I_{\max} provides information about the performance of the solid-state relay. The actual permitted rated operational current I_e can be smaller depending on the connection method and cooling conditions.

Note: The required heat sinks for the corresponding load currents can be determined from the characteristic curves, page 4/10. The minimum thickness values for the mounting surface must be observed.

Order No.	Rated impulse withstand capacity I_{tsm}	I^2t value
	A	A ² s
Main circuit		
3RF21 20-.....	200	200
3RF21 30-..A.2	300	450
3RF21 30-..A.4	300	450
3RF21 30-..A.5	300	450
3RF21 30-..A.6	400	800
3RF21 50-.....	600	1800
3RF21 70-..A.2	1200	7200
3RF21 70-..A.4	1200	7200
3RF21 70-..A.5	1200	7200
3RF21 70-..A.6	1150	6600
3RF21 90-.....	1150	6600

Type		3RF21 ..-...2	3RF21 ..-...4	3RF21 ..-...5	3RF21 ..-...6
Main circuit					
Rated operational voltage U_e	V	24 ... 230	48 ... 460	48 ... 600	48 ... 600
• Operating range	V	20 ... 253	40 ... 506	40 ... 660	40 ... 660
• Rated frequency	Hz	50/60 ± 10 %			
Rated insulation voltage U_i	V	600			
Blocking voltage	V	800	1200	1600	
Rage of voltage rise	V/μs	1000			

Type		3RF21 ..-...0.	3RF21 ..-...1.	3RF21 ..-...2.	3RF21 ..-...4.
Control circuit					
Method of operation		DC operation	AC/DC operation	AC operation	DC operation
Rated control supply voltage U_s	V	24 acc. to EN 61131-2	24 AC	24 DC	110 ... 230
Rated frequency of the control supply voltage	Hz	--	50/60 ± 10 %	--	50/60 ± 10 %
Control supply voltage, max.	V	30	26.5 AC	30 DC	253
Typical actuating current	mA	20 / Low Power: 6.5 ¹⁾	20	20	15
Response voltage	V	15	14 AC	15 DC	90
Drop-out voltage	V	5	5 AC	5 DC	40
Operating times					
• ON-delay	ms	1 + max. one half-wave ²⁾	10 + max. one half-wave ²⁾	40 + max. one half-wave ²⁾	1 + max. one half-wave ²⁾
• OFF-delay	ms	1 + max. one half-wave	15 + max. one half-wave	40 + max. one half-wave	1 + max. one half-wave

¹⁾ Applies to the version "Low Power" 3RF21 ..-AA..-0KN0.

²⁾ Only for zero-point-switching devices.

Solid-State Switching Devices for Resistive Loads

Solid-State Relays

3RF21 solid-state relays, single-phase, 22.5 mm

Fused version with semiconductor protection (similar to type of coordination "2")¹⁾

The semiconductor protection for the SIRIUS controls can be used with different protective devices. This allows protection by means of LV HRC fuses of gG operational class or miniature circuit breakers. Siemens recommends the use of special SITOR semiconductor fuses. The table below lists the maximum permissible fuses for each SIRIUS control.

If a fuse is used with a higher rated current than specified, semiconductor protection is no longer guaranteed. However, smaller fuses with a lower rated current for the load can be used without problems.

For protective devices with gG operational class and for SITOR 3NE1 all-range fuses, the minimum cross-sections for the conductor to be connected must be taken into account.

Order No.	All-range fuses		Semiconductor fuses/partial-range fuses			
	LV HRC design	Cylindrical design	LV HRC design	Cylindrical design		
	gR/SITOR	gR/NEOZED ²⁾	aR/SITOR	aR/SITOR	aR/SITOR	aR/SITOR
	3NE1	SILIZED 5SE1	3NE8	10 mm x 38 mm 3NC1 0	14 mm x 51 mm 3NC1 4	22 mm x 58 mm 3NC2 2
3RF21 20...2	3NE1 814-0	5SE1 325	3NE8 015-1	3NC1 020	3NC1 420	3NC2 220
3RF21 20...4	3NE1 813-0 ⁴⁾	5SE1 320	3NE8 015-1	3NC1 016 ⁴⁾	3NC1 420	3NC2 220
3RF21 20...5³⁾	3NE1 813-0 ⁴⁾	5SE1 320	3NE8 015-1	3NC1 016 ⁴⁾	3NC1 420	3NC2 220
3RF21 30...2	3NE1 815-0 ⁴⁾	5SE1 335	3NE8 003-1	3NC1 032	3NC1 432	3NC2 232
3RF21 30...4	3NE1 815-0 ⁴⁾	5SE1 325 ⁴⁾	3NE8 003-1	3NC1 025 ⁴⁾	3NC1 430	3NC2 232
3RF21 30...5³⁾	3NE1 815-0 ⁴⁾	5SE1 325 ⁴⁾	3NE8 003-1	3NC1 025 ⁴⁾	3NC1 430	3NC2 232
3RF21 30...6	3NE1 815-0 ⁴⁾	--	3NE8 003-1	3NC1 032	3NC1 432	3NC2 232
3RF21 50...2	3NE1 817-0	5SE1 350	3NE8 017-1	--	3NC1 450	3NC2 250
3RF21 50...4	3NE1 802-0 ⁴⁾	5SE1 335 ⁴⁾	3NE8 017-1	--	3NC1 450	3NC2 250
3RF21 50...5³⁾	3NE1 802-0 ⁴⁾	5SE1 335 ⁴⁾	3NE8 017-1	--	3NC1 450	3NC2 250
3RF21 50...6	3NE1 803-0 ⁴⁾	--	3NE8 017-1	--	3NC1 450	3NC2 250
3RF21 70...2⁵⁾	3NE1 820-0	5SE1 363 ⁴⁾	3NE8 020-1	--	--	3NC2 280
3RF21 70...4⁵⁾	3NE1 020-2	5SE1 363 ⁴⁾	3NE8 020-1	--	--	3NC2 280
3RF21 70...5³⁾⁵⁾	3NE1 020-2	--	3NE8 020-1	--	--	3NC2 280
3RF21 70...6⁵⁾	3NE1 020-2	--	3NE8 020-1	--	--	3NC2 280
3RF21 90...2⁵⁾	3NE1 021-2	--	3NE8 021-1	--	--	3NC2 200
3RF21 90...4⁵⁾	3NE1 021-2	--	3NE8 021-1	--	--	3NC2 280 ⁴⁾
3RF21 90...5³⁾⁵⁾	3NE1 021-2	--	3NE8 021-1	--	--	3NC2 280 ⁴⁾
3RF21 90...6⁵⁾	3NE1 817-0 ⁴⁾	--	3NE8 021-1	--	--	3NC2 280 ⁴⁾

Order No.	Cable and line protection fuses				
	LV HRC design ⁴⁾	Cylindrical design ⁴⁾			DIAZED ⁴⁾
	gG	gG	gG	gG	quick
	3NA2	10 mm x 38 mm 3NW6 0	14 mm x 51 mm 3NW6 1	22 mm x 58 mm 3NW6 2	5SB
3RF21 20...2	3NA2 803	3NW6 000-1	3NW6 101-1	--	5SB1 41
3RF21 20...4	3NA2 801	--	3NW6 101-1	--	5SB1 41
3RF21 20...5³⁾	3NA2 801	--	3NW6 101-1	--	5SB1 41
3RF21 30...2	3NA2 803	--	3NW6 103-1	--	5SB1 71
3RF21 30...4	3NA2 803	--	3NW6 101-1	--	5SB1 71
3RF21 30...5³⁾	3NA2 803	--	3NW6 101-1	--	5SB1 71
3RF21 30...6	3NA2 803-6	--	--	--	--
3RF21 50...2	3NA2 810	--	3NW6 107-1	3NW6 207-1	5SB3 11
3RF21 50...4	3NA2 807	--	--	3NW6 205-1	5SB3 11
3RF21 50...5³⁾	3NA2 807	--	--	3NW6 205-1	5SB3 11
3RF21 50...6	3NA2 807-6	--	--	--	--
3RF21 70...2⁵⁾	3NA2 817	--	--	3NW6 217-1	5SB3 31
3RF21 70...4⁵⁾	3NA2 812	--	--	3NW6 212-1	5SB3 31
3RF21 70...5³⁾⁵⁾	3NA2 812	--	--	3NW6 212-1	--
3RF21 70...6⁵⁾	3NA2 812-6	--	--	--	--
3RF21 90...2⁵⁾	3NA2 817	--	--	3NW6 217-1	--
3RF21 90...4⁵⁾	3NA2 812	--	--	3NW6 212-1	--
3RF21 90...5³⁾⁵⁾	3NA2 812	--	--	3NW6 212-1	--
3RF21 90...6⁵⁾	3NA2 812-6	--	--	--	--

Suitable fuse holders, fuse bases and controls can be found in Catalog LV 1, Chapter 19.

- 1) Type of coordination "2" according to EN 60947-4-1:
In the event of a short-circuit, the controls in the load feeder must not endanger persons or the installation. They must be suitable for further operation. For fused configurations, the protective device must be replaced.
- 2) For use only with operational voltage U_o up to 400 V.
- 3) For use only with operational voltage U_o up to 506 V.
- 4) These fuses have a smaller rated current than the solid-state relays.
- 5) These versions can also be protected against short-circuits with miniature circuit breakers as described in the notes on "SIRIUS Solid-State Contactors → Special Version Short-Circuit Resistant".

Solid-State Switching Devices for Resistive Loads

Solid-State Relays

3RF21 solid-state relays, single-phase, 22.5 mm

Characteristic curves

Dependence of the device current I_e on the ambient temperature T_a and the heat sink resistance R_{thha}

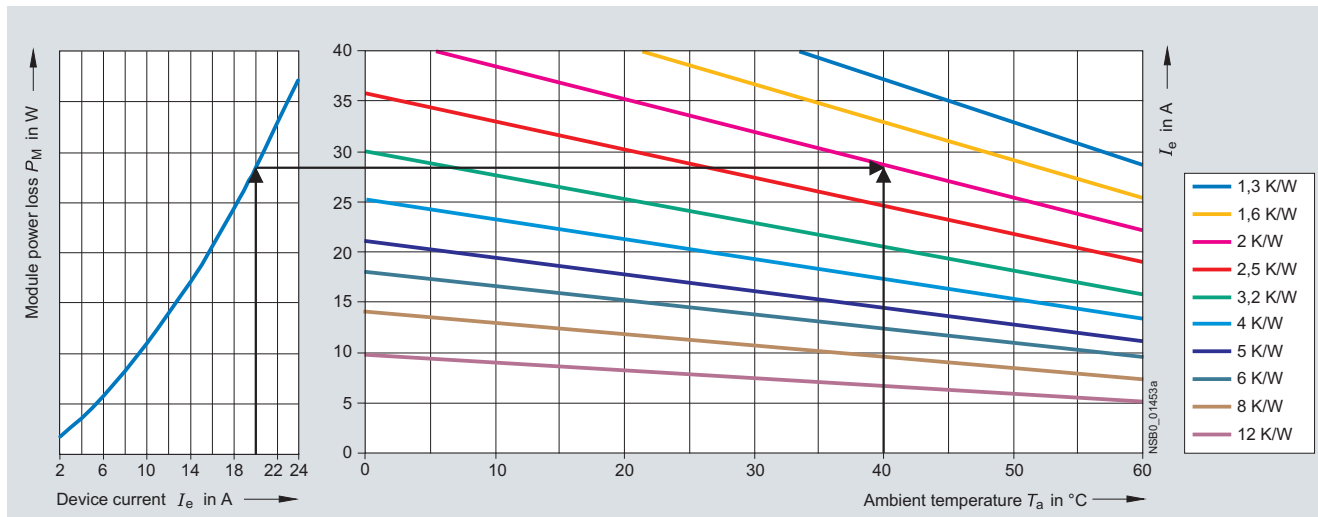

Type current 20 A (3RF21 20, 3RF20 20)¹⁾

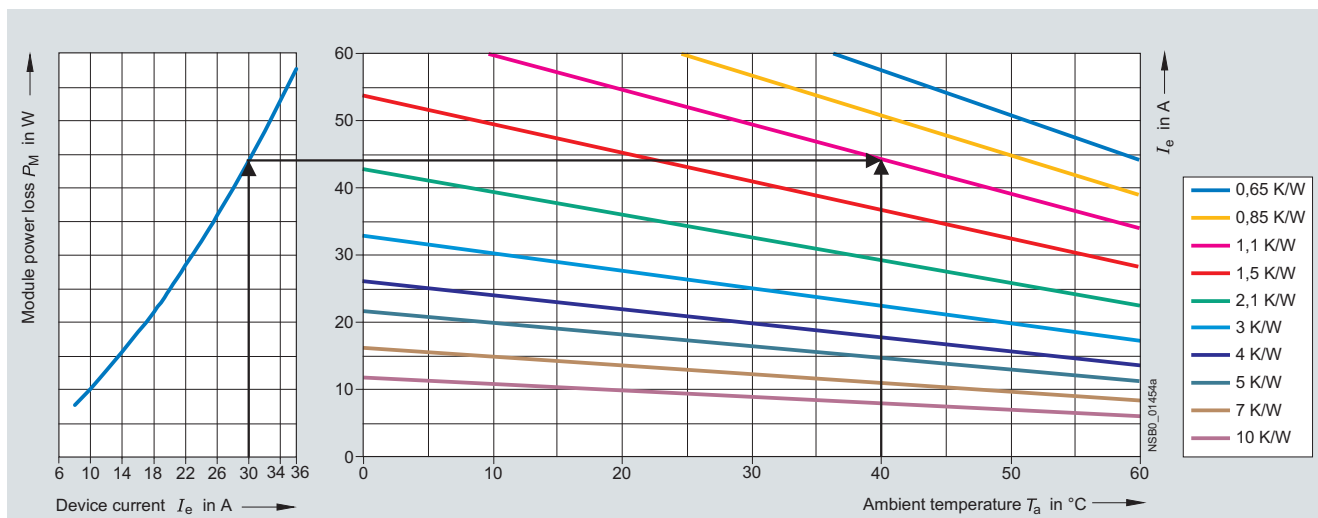

Type current 30 A (3RF21 30, 3RF20 30)

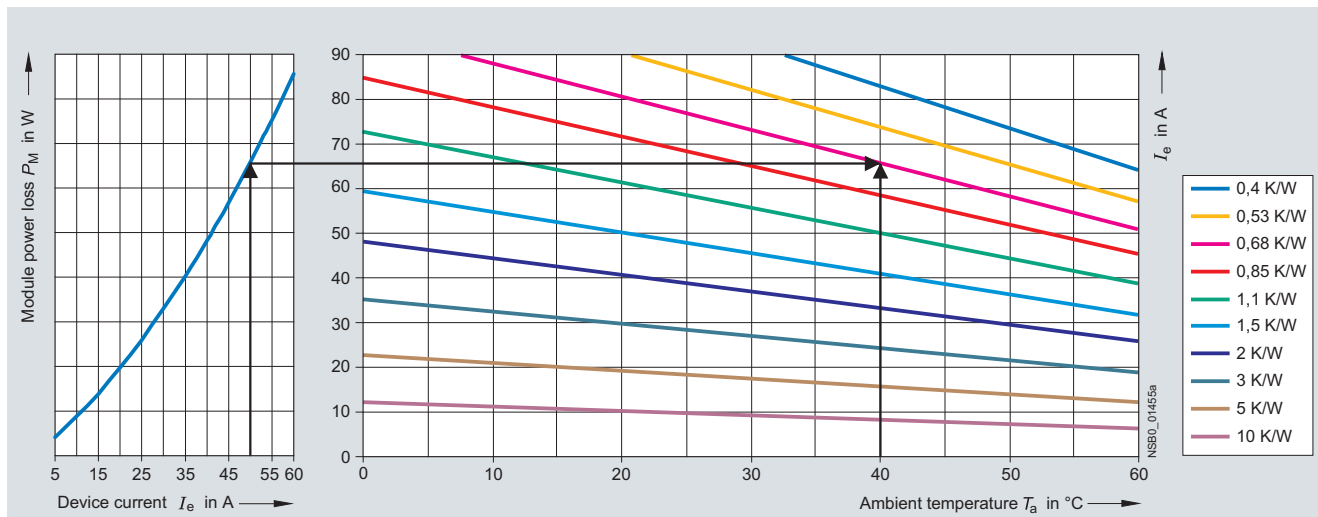

Type current 50 A (3RF21 50, 3RF20 50)

¹⁾ For arrangement example see next page.

4

Solid-State Switching Devices for Resistive Loads

Solid-State Relays

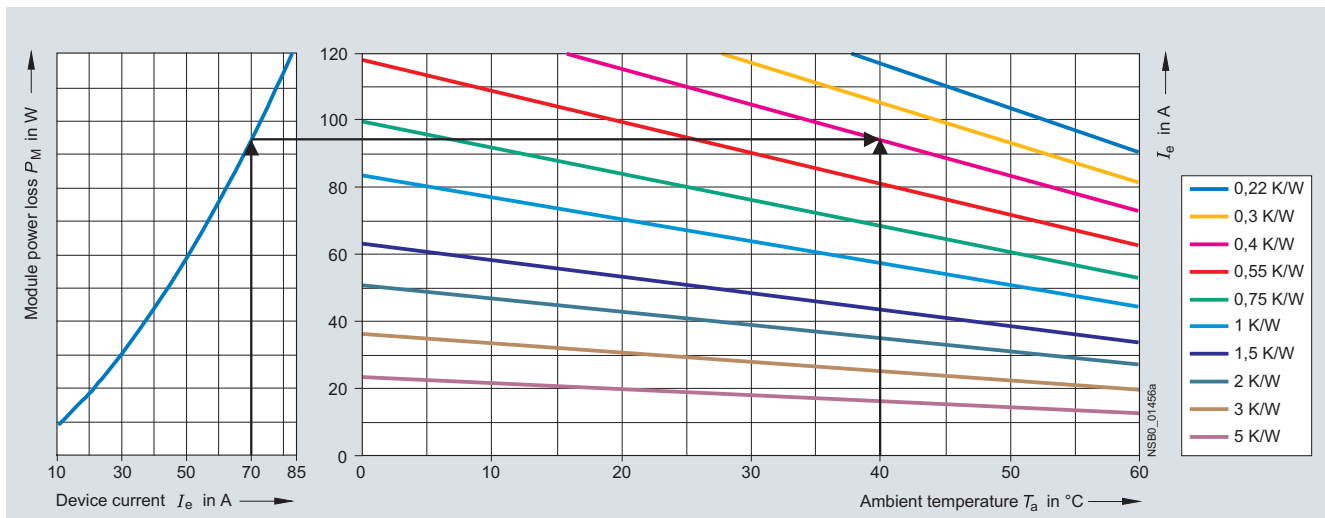
3RF21 solid-state relays, single-phase, 22.5 mm

Type current 70 A (3RF21 70, 3RF20 70)

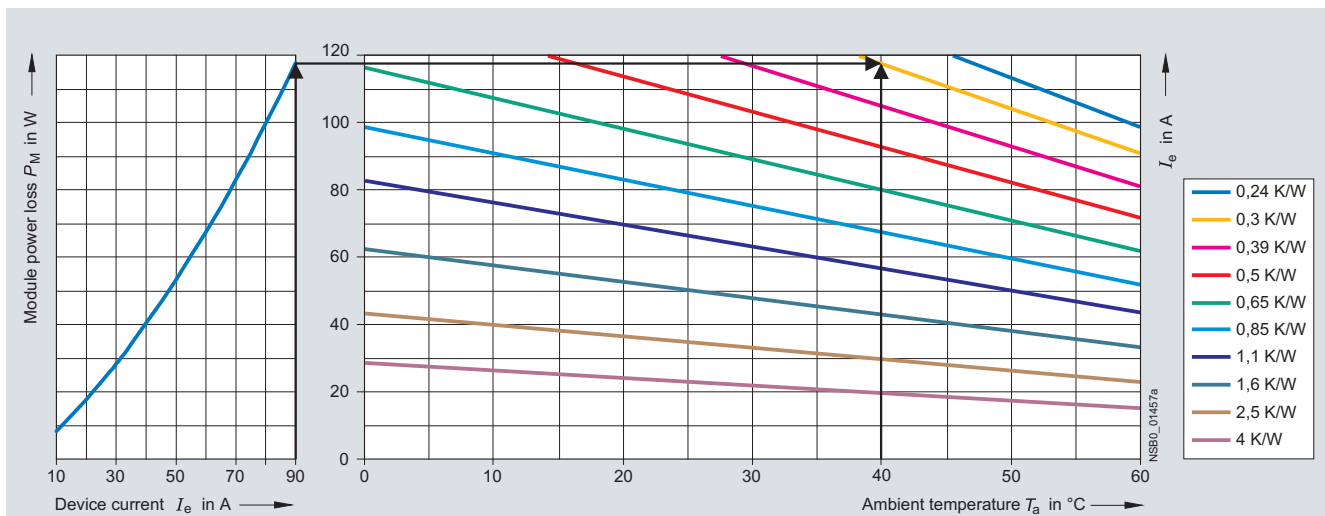

Type current 90 A (3RF21 90, 3RF20 90)

Arrangement example

Given conditions: $I_e = 20$ A and $T_a = 40$ °C. The task is to find the thermal resistance R_{thha} and the heat sink overtemperature dT_{ha} .

From the diagram on the left $\rightarrow P_M = 28$ W,
 from the diagram on the right $\rightarrow R_{thha} = 2.0$ K/W.

This results in:

$$dT_{ha} = R_{thha} \times PM = 2.0 \text{ K/W} \times 28 \text{ W} = 56 \text{ K.}$$

At $dT_{ha} = 56$ K the heat sink must therefore have an
 $R_{thha} = 2.0$ K/W.

Solid-State Switching Devices for Resistive Loads

Solid-State Relays

3RF21 solid-state relays, single-phase, 22.5 mm

Dimensional drawings

Solid-state relays

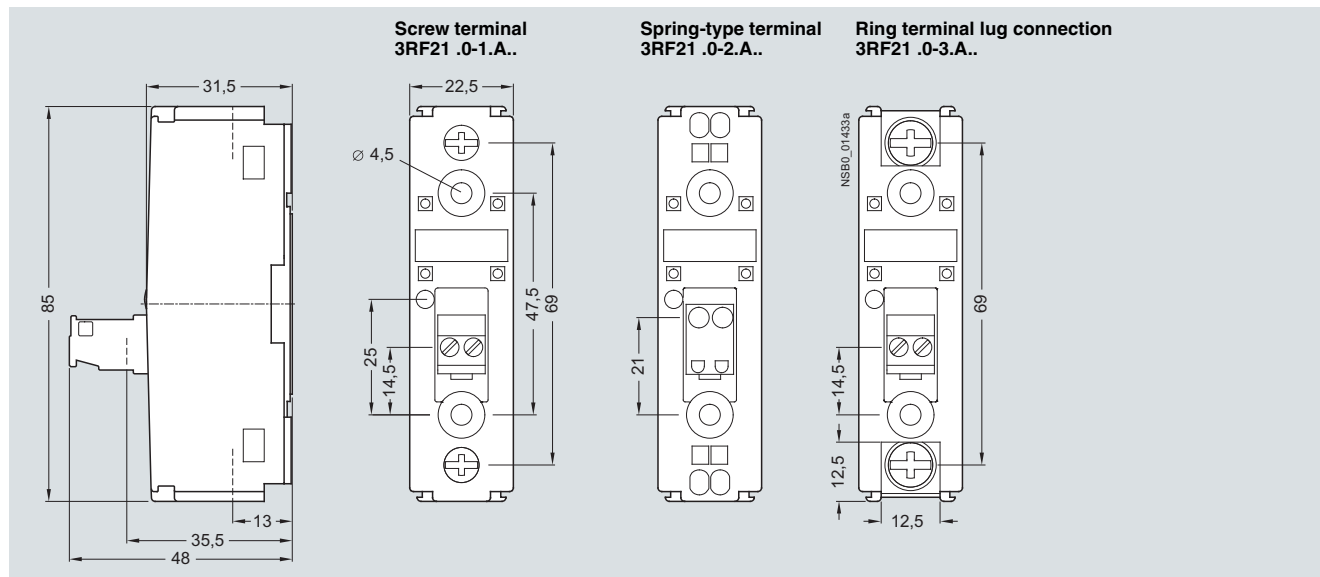

Terminal cover

3RF29 00-3PA88

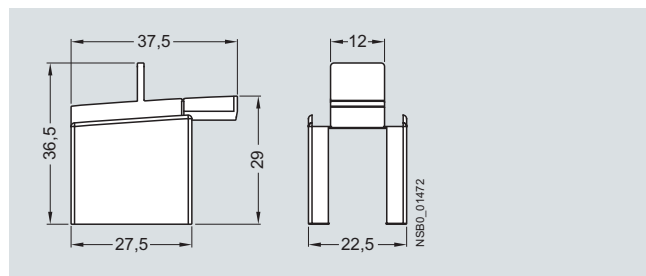

Schematics

Version
DC control supply voltage

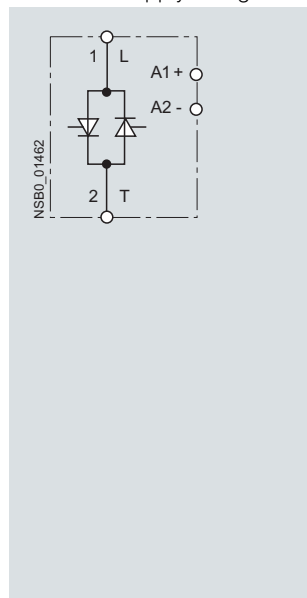

Version
AC control supply voltage

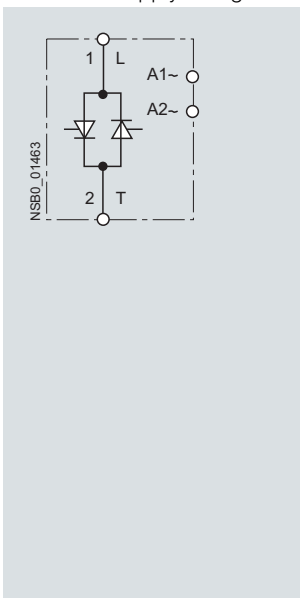

Switching example

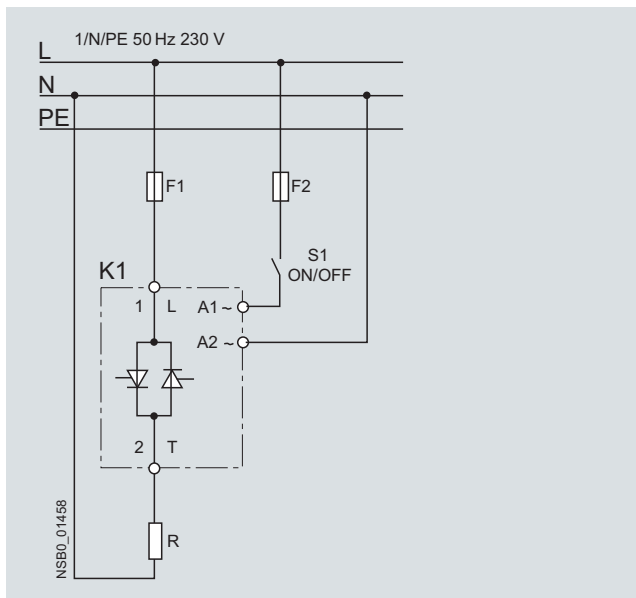

Solid-State Switching Devices for Resistive Loads

Solid-State Relays



3RF20 solid-state relays, single-phase, 45 mm

Overview

45 mm solid-state relays

The solid-state relays with a width of 45 mm provide for connection of the power supply lead and the load from above. This makes it easy to replace existing solid-state relays in existing arrangements. The connection of the control cable also saves space in much the same way as the 22.5 mm design, as it is simply plugged on.

Technical specifications

Type		3RF20 ..-1....	3RF20 ..-4....
General data			
Ambient temperature			
• During operation, derating from 40 °C	°C	-25 ... +60	
• During storage	°C	-55 ... +80	
Installation altitude	m	0 ... 1000; derating from 1000	
Shock resistance acc. to IEC 60068-2-27	g/ms	15/11	
Vibration resistance acc. to IEC 60068-2-6	g	2	
Degree of protection		IP20	
Electromagnetic compatibility (EMC)			
• Emitted interference			
- Conducted interference voltage acc. to IEC 60947-4-3		Class A for industrial applications	
- Emitted, high-frequency interference voltage acc. to IEC 60947-4-3		Class A for industrial applications	
• Interference immunity			
- Electrostatic discharge acc. to IEC 61000-4-2 (corresponds to degree of severity 3)	kV	Contact discharge 4; air discharge 8; behavior criterion 2	
- Induced RF fields acc. to IEC 61000-4-6	MHz	0.15 ... 80; 140 dBµV; behavior criterion 1	
- Burst acc. to IEC 61000-4-4	kV	2/5.0 kHz; behavior criterion 1	
- Surge acc. to IEC 61000-4-5	kV	Conductor - ground 2; conductor - conductor 1; behavior criterion 2	
Connection type		 Screw terminals	 Spring-type terminals
Connection, main contacts			
• Conductor cross-section	mm ²	2 x (1.5 ... 2.5) ¹⁾ , 2 x (2.5 ... 6) ¹⁾	
- Solid	mm ²	--	
- Finely stranded with end sleeve	mm ²	2 x (1 ... 2.5) ¹⁾ , 2 x (2.5 ... 6) ¹⁾ , 1 x 10	
- Solid or stranded, AWG cables		2x (AWG 14 ... 10)	
• Terminal screw		M4	
• Tightening torque	Nm	2 ... 2.5	
	lb.in	7 ... 10.3	
Connection, auxiliary/control contacts			
• Conductor cross-section	mm ²	1 x (0.5 ... 2.5), 2 x (0.5 ... 1.0), AWG 20 ... 12	0.5 ... 2.5, AWG 20 ... 12
• Stripped length	mm	7	
• Terminal screw		M3	
• Tightening torque	Nm	0.5 ... 0.6	
	lb.in	4.5 ... 5.3	

¹⁾ If two different conductor cross-sections are connected to one clamping point, both cross-sections must lie in the range specified. If identical cross-sections are used, this restriction does not apply.

Solid-State Switching Devices for Resistive Loads

Solid-State Relays

3RF20 solid-state relays, single-phase, 45 mm

Order No.	$I_{\max}^{1)}$ at $R_{\text{thha}}/T_u = 40\text{ °C}$		I_e acc. to IEC 60947-4-3 at $R_{\text{thha}}/T_u = 40\text{ °C}$		I_e acc. to UL/CSA at $R_{\text{thha}}/T_u = 50\text{ °C}$		Power loss at I_{\max}	Minimum load current	Leakage current
	A	K/W	A	K/W	A	K/W			
Main circuit									
3RF20 20-1.A..	20	2.0	20	1.7	20	1.3	28.6	0.1	10
3RF20 30-1.A..	30	1.1	30	0.79	30	0.56	44.2	0.5	10
3RF20 50-1.A..	50	0.68	50	0.48	50	0.33	66	0.5	10
3RF20 70-1.A..	70	0.40	50	0.77	50	0.6	94	0.5	10
3RF20 90-1.A..	88	0.33	50	0.94	50	0.85	118	0.5	10

¹⁾ I_{\max} provides information about the performance of the solid-state relay. The actual permitted rated operational current I_e can be smaller depending on the connection method and cooling conditions.

Note: The required heat sinks for the corresponding load currents can be determined from the characteristic curves, page 4/10. The minimum thickness values for the mounting surface must be observed.

Order No.	Rated impulse withstand capacity I_{tsm}		I^2t value
	A	A	
Main circuit			
3RF20 20-1.A..	200		200
3RF20 30-1.A.2	300		450
3RF20 30-1.A.4	300		450
3RF20 30-1.A.6	400		800
3RF20 50-1.A..	600		1800
3RF20 70-1.A.2	1200		7200
3RF20 70-1.A.4	1200		7200
3RF20 70-1.A.5	1200		7200
3RF20 70-1.A.6	1150		6600
3RF20 90-1.A..	1150		6600

Type		3RF20 .0-1.A.2	3RF20 .0-1.A.4	3RF20 .0-1.A.5	3RF20 .0-1.A.6
Main circuit					
Rated operational voltage U_e	V	24 ... 230	48 ... 460	48 ... 600	48 ... 600
• Operating range	V	20 ... 253	40 ... 506	40 ... 660	40 ... 660
• Rated frequency	Hz	50/60 ± 10 %			
Rated insulation voltage U_i	V	600			
Blocking voltage	V	800	1200	1600	
Rate of voltage rise	V/μs	1000			

Type		3RF20 .0-1.A.0.	3RF20 .0-1.A.2.	3RF20 .0-1.A.4.
Control circuit				
Method of operation		DC operation	AC operation	DC operation
Rated control supply voltage U_S	V	24 acc. to EN 61131-2	110 ... 230	4 ... 30
Rated frequency of the control supply voltage	Hz	--	50/60 ± 10 %	--
Control supply voltage, max.	V	30	253	30
Typical actuating current	mA	20	15	20
Response voltage	V	15	90	4
Drop-out voltage	V	5	40	1
Operating times				
• ON-delay	ms	1 + max. one half-wave ¹⁾	40 + max. one half-wave ¹⁾	1 + max. one half-wave ¹⁾
• OFF-delay	ms	1 + max. one half-wave	40 + max. one half-wave	1 + max. one half-wave

¹⁾ Only for zero-point-switching devices.

Solid-State Switching Devices for Resistive Loads

Solid-State Relays

3RF20 solid-state relays, single-phase, 45 mm

Fused version with semiconductor protection (similar to type of coordination "2")¹⁾

The semiconductor protection for the SIRIUS controls can be used with different protective devices. This allows protection by means of LV HRC fuses of gG operational class or miniature circuit breakers. Siemens recommends the use of special SITOR semiconductor fuses. The table below lists the maximum permissible fuses for each SIRIUS control.

If a fuse is used with a higher rated current than specified, semiconductor protection is no longer guaranteed. However, smaller fuses with a lower rated current for the load can be used without problems.

For protective devices with gG operational class and for SITOR 3NE1 all-range fuses, the minimum cross-sections for the conductor to be connected must be taken into account.

Order No.	All-range fuses		Semiconductor fuses/partial-range fuses			
	LV HRC design	Cylindrical design	LV HRC design	Cylindrical design		
	gR/SITOR	gR/NEOZED ²⁾	aR/SITOR	aR/SITOR	aR/SITOR	aR/SITOR
	3NE1	SILIZED 5SE1	3NE8	10 mm x 38 mm 3NC1 0	14 mm x 51 mm 3NC1 4	22 mm x 58 mm 3NC2 2
3RF20 20-1.A.2	3 NE1 814-0	5SE1 325	3 NE8 015-1	3NC1 020	3NC1 420	3NC2 220
3RF20 20-1.A.4	3 NE1 813-0 ⁴⁾	5SE1 320	3 NE8 015-1	3NC1 016 ⁴⁾	3NC1 420	3NC2 220
3RF20 20-1.A.5³⁾	3 NE1 813-0 ⁴⁾	5SE1 320	3 NE8 015-1	3NC1 016 ⁴⁾	3NC1 420	3NC2 220
3RF20 30-1.A.2	3 NE1 815-0 ⁴⁾	5SE1 335	3 NE8 003-1	3NC1 032	3NC1 432	3NC2 232
3RF20 30-1.A.4	3 NE1 815-0 ⁴⁾	5SE1 325 ⁴⁾	3 NE8 003-1	3NC1 025 ⁴⁾	3NC1 430	3NC2 232
3RF20 30-1.A.6	3 NE1 815-0 ⁴⁾	--	3 NE8 003-1	3NC1 032	3NC1 432	3NC2 232
3RF20 50-1.A.2	3 NE1 817-0	5SE1 350	3 NE8 017-1	--	3NC1 450	3NC2 250
3RF20 50-1.A.4	3 NE1 802-0 ⁴⁾	5SE1 335 ⁴⁾	3 NE8 017-1	--	3NC1 450	3NC2 250
3RF20 50-1.A.5³⁾	3 NE1 802-0 ⁴⁾	5SE1 335 ⁴⁾	3 NE8 017-1	--	3NC1 450	3NC2 250
3RF20 50-1.A.6	3 NE1 803-0 ⁴⁾	--	3 NE8 017-1	--	3NC1 450	3NC2 250
3RF20 70-1.A.2⁵⁾	3 NE1 820-0	5SE1 363 ⁴⁾	3 NE8 020-1	--	--	3NC2 280
3RF20 70-1.A.4⁵⁾	3 NE1 020-2	5SE1 363 ⁴⁾	3 NE8 020-1	--	--	3NC2 280
3RF20 70-1.A.5³⁾⁵⁾	3 NE1 020-2	--	3 NE8 020-1	--	--	3NC2 280
3RF20 70-1.A.6⁵⁾	3 NE1 020-2	--	3 NE8 020-1	--	--	3NC2 280
3RF20 90-1.A.2⁵⁾	3 NE1 021-2	--	3 NE8 021-1	--	--	3NC2 200
3RF20 90-1.A.4⁵⁾	3 NE1 021-2	--	3 NE8 021-1	--	--	3NC2 280 ⁴⁾
3RF20 90-1.A.5³⁾⁵⁾	3 NE1 021-2	--	3 NE8 021-1	--	--	3NC2 280 ⁴⁾
3RF20 90-1.A.6⁵⁾	3 NE1 817-0 ⁴⁾	--	3 NE8 021-1	--	--	3NC2 280 ⁴⁾

Order No.	Cable and line protection fuses				
	LV HRC design ⁴⁾	Cylindrical design ⁴⁾			DIAZED ⁴⁾
	gG	gG	gG	gG	quick
	3NA2	10 mm x 38 mm 3NW6 0	14 mm x 51 mm 3NW6 1	22 mm x 58 mm 3NW6 2	5SB
3RF20 20-1.A.2	3NA2 803	3NW6 001-1	3NW6 101-1	--	5SB1 41
3RF20 20-1.A.4	3NA2 801	--	3NW6 101-1	--	5SB1 41
3RF20 20-1.A.5³⁾	3NA2 801	--	3NW6 101-1	--	5SB1 41
3RF20 30-1.A.2	3NA2 803	--	3NW6 103-1	--	5SB1 71
3RF20 30-1.A.4	3NA2 803	--	3NW6 101-1	--	5SB1 71
3RF20 30-1.A.6	3NA2 803-6	--	--	--	--
3RF20 50-1.A.2	3NA2 810	--	3NW6 107-1	3NW6 207-1	5SB3 11
3RF20 50-1.A.4	3NA2 807	--	--	3NW6 205-1	5SB3 11
3RF20 50-1.A.5³⁾	3NA2 807	--	--	3NW6 205-1	5SB3 11
3RF20 50-1.A.6	3NA2 807-6	--	--	--	--
3RF20 70-1.A.2⁵⁾	3NA2 817	--	--	3NW6 217-1	5SB3 31
3RF20 70-1.A.4⁵⁾	3NA2 812	--	--	3NW6 212-1	5SB3 31
3RF20 70-1.A.5³⁾⁵⁾	3NA2 812	--	--	3NW6 212-1	--
3RF20 70-1.A.6⁵⁾	3NA2 812-6	--	--	--	--
3RF20 90-1.A.2⁵⁾	3NA2 817	--	--	3NW6 217-1	--
3RF20 90-1.A.4⁵⁾	3NA2 812	--	--	3NW6 212-1	--
3RF20 90-1.A.5³⁾⁵⁾	3NA2 812	--	--	3NW6 212-1	--
3RF20 90-1.A.6⁵⁾	3NA2 812-6	--	--	--	--

Suitable fuse holders, fuse bases and controls can be found in Catalog LV 1, Chapter 19.

¹⁾ Type of coordination "2" according to EN 60947-4-1:

In the event of a short-circuit, the controls in the load feeder must not endanger persons or the installation. They must be suitable for further operation. For fused configurations, the protective device must be replaced.

²⁾ For use only with operational voltage U_e up to 400 V.

³⁾ For use only with operational voltage U_e up to 506 V.

⁴⁾ These fuses have a smaller rated current than the solid-state relays.

⁵⁾ These versions can also be protected against short-circuits with miniature circuit breakers as described in the notes on "SIRIUS Solid-State Contactors → Special Version Short-Circuit Resistant".

Characteristic curves

See 3RF21 solid-state relays, page 4/10.

Solid-State Switching Devices for Resistive Loads

Solid-State Relays

3RF20 solid-state relays, single-phase, 45 mm

Dimensional drawings

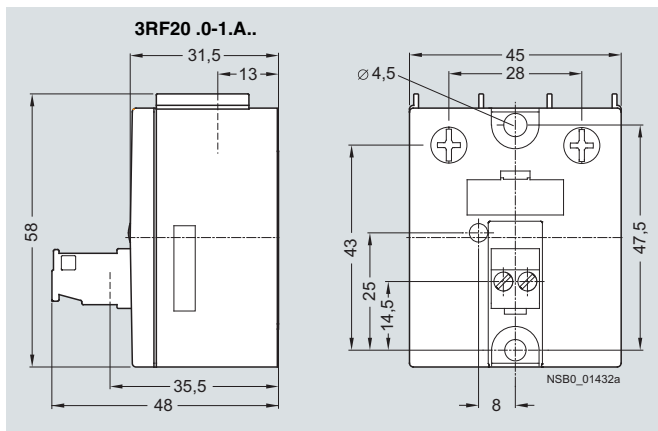

Schematics

Version
DC control supply voltage

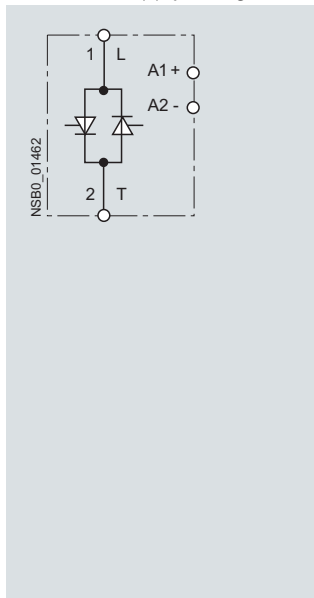

Version
AC control supply voltage

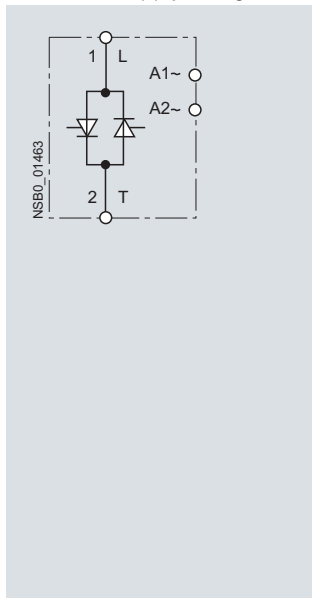

Switching example

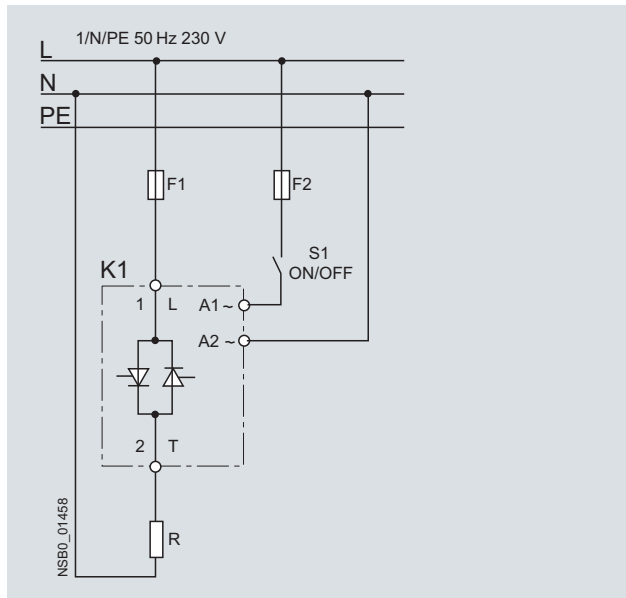

4

Solid-State Switching Devices for Resistive Loads

Solid-State Relays

3RF22 solid-state relays, three-phase, 45 mm

Overview



45 mm solid-state relays

The 3RF22 solid-state relays with a width of 45 mm provide space advantages over solutions with single-phase versions. The logical connection method, with the power infeed from above and load connection from below, ensures tidy installation in the control cabinet.

Important features:

- LED display
- Variety of connection methods
- Plug-in control connection
- Degree of protection IP20
- Zero-point switching
- Two- or three-phase controlled

Technical specifications

Type		3RF22 ..-1....	3RF22 ..-2....	3RF22 ..-3....
General data				
Ambient temperature				
• During operation, derating from 40 °C	°C	-25 ... + 60		
• During storage	°C	-55 ... + 80		
Installation altitude	m	0 ... 1000; > 1000 ask Technical Assistance		
Shock resistance acc. to IEC 60068-2-27	g/ms	15/11		
Vibration resistance acc. to IEC 60068-2-6	g	2		
Degree of protection		IP20		
Insulation strength at 50/60 Hz (main/control circuit to floor)	V rms	4000		
Electromagnetic compatibility (EMC)				
• Emitted interference				
- Conducted interference voltage acc. to IEC 60947-4-3		Class A for industrial applications ¹⁾		
- Emitted, high-frequency interference voltage acc. to IEC 60947-4-3		Class A for industrial applications		
• Interference immunity				
- Electrostatic discharge acc. to IEC 61000-4-2 (corresponds to degree of severity 3)	kV	Contact discharge 4; air discharge 8; behavior criterion 2		
- Induced RF fields acc. to IEC 61000-4-6	MHz	0.15 ... 80; 140 dBµV; behavior criterion 1		
- Burst acc. to IEC 61000-4-4	kV	2/5.0 kHz; behavior criterion 1		
- Surge acc. to IEC 61000-4-5	kV	Conductor - ground 2; conductor - conductor 1; behavior criterion 2		
Connection type		 Screw terminals	 Spring-type terminals	 Ring terminal lug connection
Connection, main contacts				
• Conductor cross-section				
- Solid	mm ²	2 x (1.5 ... 2.5) ²⁾ , 2 x (2.5 ... 6) ²⁾		2 x (0.5 ... 2.5)
- Finely stranded with end sleeve	mm ²	2 x (1 ... 2.5) ²⁾ , 2 x (2.5 ... 6) ²⁾ , 1 x 10		2 x (0.5 ... 1.5)
- Finely stranded without end sleeve	mm ²	--		--
- Solid or stranded, AWG cables		2 x (AWG 14 ... 10)		2 x (AWG 18 ... 14)
• Stripped length	mm	10		10
• Terminal screw		M4		--
- Tightening torque, Ø 5 ... 6 mm, PZ 2	Nm	2 ... 2.5		M5 2.5 ... 2
	lb.in	18 ... 22		18 ... 22
• Cable lug		--		--
- Acc. to DIN 46234				5-2.5 ... 5-25
- Acc. to JIS C 2805				R 2-5 ... 14-5
Connection, auxiliary/control contacts				
• Conductor cross-section, with or without end sleeve				
	mm	1 x (0.5 ... 2.5), 2 x (0.5 ... 1.0)		0.5 ... 2.5
	AWG	20 ... 12		20 ... 12
• Stripped length	mm	7		10
• Terminal screw		M3		--
- Tightening torque, Ø 3.5, PZ 1	Nm	0.5 ... 0.6		M3 0.5 ... 0.6
	lb.in	4.5 ... 5.3		4.5 ... 5.3

¹⁾ These products were built as Class A devices. The use of these devices in residential areas could result in lead in radio interference. In this case these may be required to introduce additional interference suppression measures.

²⁾ If two different conductor cross-sections are connected to one clamping point, both cross-sections must lie in the range specified. If identical cross-sections are used, this restriction does not apply.

Solid-State Switching Devices for Resistive Loads

Solid-State Relays

3RF22 solid-state relays, three-phase, 45 mm

Order No.	$I_{\max}^{1)}$ at $R_{\text{thha}}/T_u = 40\text{ °C}$		I_e acc. to IEC 60947-4-3 at $R_{\text{thha}}/T_u = 40\text{ °C}$		I_e acc. to UL/CSA at $R_{\text{thha}}/T_u = 50\text{ °C}$		Power loss at I_{\max}	Minimum load current	Max. leakage current
	A	K/W	A	K/W	A	K/W			
Main circuit									
3RF22 30-. AB..	30	0.57	30	0.57	30	0.44	81	0.5	10
3RF22 55-1AB..	55	0.18	50	0.27	50	0.19	151	0.5	10
3RF22 55-2AB..			20	1.83	20	1.58			
3RF22 55-3AB..			50	0.27	50	0.19			
3RF22 30-. AC..	30	0.33	30	0.33	30	0.25	122	0.5	10
3RF22 55-1AC..	55	0.09	50	0.15	50	0.1	226	0.5	10
3RF22 55-2AC..			20	1.19	20	1.02			
3RF22 55-3AC..			50	0.15	50	0.1			

1) I_{\max} provides information about the performance of the solid-state relay. The actual permitted rated operational current I_e can be smaller depending on the connection method and cooling conditions.

Note: The required heat sinks for the corresponding load currents can be determined from the characteristic curves, page 4/20. The minimum thickness values for the mounting surface must be observed.

Order No.	Rated impulse withstand capacity I_{tsm}	I^2t value
	A	A ² s
Main circuit		
3RF22 30-...5	300	450
3RF22 55-...5	600	1800

Type	3RF22 ...-AB.5	3RF22 ...-AC.5
Main circuit		
Controlled phases	Two-phase	Three-phase
Rated operational voltage U_e	V 48 ... 600	48 ... 600
• Operating range	V 40 ... 660	40 ... 660
• Rated frequency	Hz 50/60 ± 10 %	50/60 ± 10 %
Rated insulation voltage U_i	V 600	600
Rated impulse withstand voltage U_{imp}	kV 6	6
Blocking voltage	V 1200	1200
Rage of voltage rise	V/μs 1000	1000

Type	3RF22 ...-A.3.	3RF22 ...-A.4.
Control circuit		
Method of operation	AC operation	DC operation
Rated control supply voltage U_s	V 110	4 ... 30
Rated frequency of the control supply voltage	50/60 ± 10 %	--
Control supply voltage, max.	V 121	30
Typical actuating current	mA 15	30
Response voltage	V 90	4
Drop-out voltage	V < 40	1
Operating times		
• ON-delay	ms 40 + max. one half-wave	1 + max. one half-wave
• OFF-delay	ms 40 + max. one half-wave	1 + max. one half-wave

Solid-State Switching Devices for Resistive Loads

Solid-State Relays

3RF22 solid-state relays, three-phase, 45 mm

Fused version with semiconductor protection (similar to type of coordination "2")¹⁾

The semiconductor protection for the 3RF22 controls can be used with different protective devices. Siemens recommends the use of special SITOR semiconductor fuses. The table below lists the maximum permissible fuses for each 3RF22 control.

If a fuse is used with a higher rated current than specified, semiconductor protection is no longer guaranteed. However, smaller fuses with a lower rated current for the load can be used without problems.

Order No.	All-range fuses		Semiconductor fuses/partial-range fuses			
	LV HRC design gR/SITOR 3NE1	Cylindrical design gR/NEOZED ²⁾ SILIZED 5SE1	LV HRC design aR/SITOR 3NE8	Cylindrical design aR/SITOR 10 mm x 38 mm 3NC1 0	aR/SITOR 14 mm x 51 mm 3NC1 4	aR/SITOR 22 mm x 58 mm 3NC2 2
Operational voltage U_e up to 460 V (+10 %)						
3RF22 30-.....	3NE1 814-0 ³⁾	5SE1 325 ³⁾	3NE8 003-1	3NC1 032	3NC1 430	3NC2 232
3RF22 55-.....	3NE1 802-0 ³⁾	5SE1 350 ³⁾	3NE8 018-1	--	3NC1 450	3NC2 263
Operational voltage U_e up to 600 V (+10 %)						
3RF22 30-.....	3NE1 814-0 ³⁾	--	3NE8 003-1	3NC1 025 ³⁾	3NC1 430	3NC2 232
3RF22 55-.....	3NE1 803-0 ³⁾	--	3NE8 018-1	--	3NC1 450 ³⁾	3NC2 250 ³⁾

Order No.	Cable and line protection fuses				
	LV HRC design ³⁾ gG 3NA3	Cylindrical design ³⁾ gG 10 mm x 38 mm 3NW6 0	gG 14 mm x 51 mm 3NW6 1	gG 22 mm x 58 mm 3NW6 2	DIAZED ³⁾ quick 5SB
Operational voltage U_e up to 460 V (+10 %)					
3RF22 30-.....	3NA3 803-6	--	3NW6 101-1	3NW6 205-1	5SB1 71
3RF22 55-.....	3NA3 807-6	--	--	--	5SB3 11
Operational voltage U_e up to 600 V (+10 %)					
3RF22 30-.....	3NA3 803-6	--	--	--	--
3RF22 55-.....	3NA3 805-6	--	--	--	--

Suitable fuse holders, fuse bases and controls can be found in Catalog LV 1, Chapter 19.

- 1) Type of coordination "2" according to EN 60947-4-1:
In the event of a short-circuit, the controls in the load feeder must not endanger persons or the installation. They must be suitable for further operation. For fused configurations, the protective device must be replaced.
- 2) For use only with operational voltage U_e up to 400 V.
- 3) These fuses have a smaller rated current than the solid-state relays.

Solid-State Switching Devices for Resistive Loads

Solid-State Relays

3RF22 solid-state relays, three-phase, 45 mm

Characteristic curves

Dependence of the device current I_e on the ambient temperature T_a and the heat sink resistance R_{thha} (two-phase controlled)

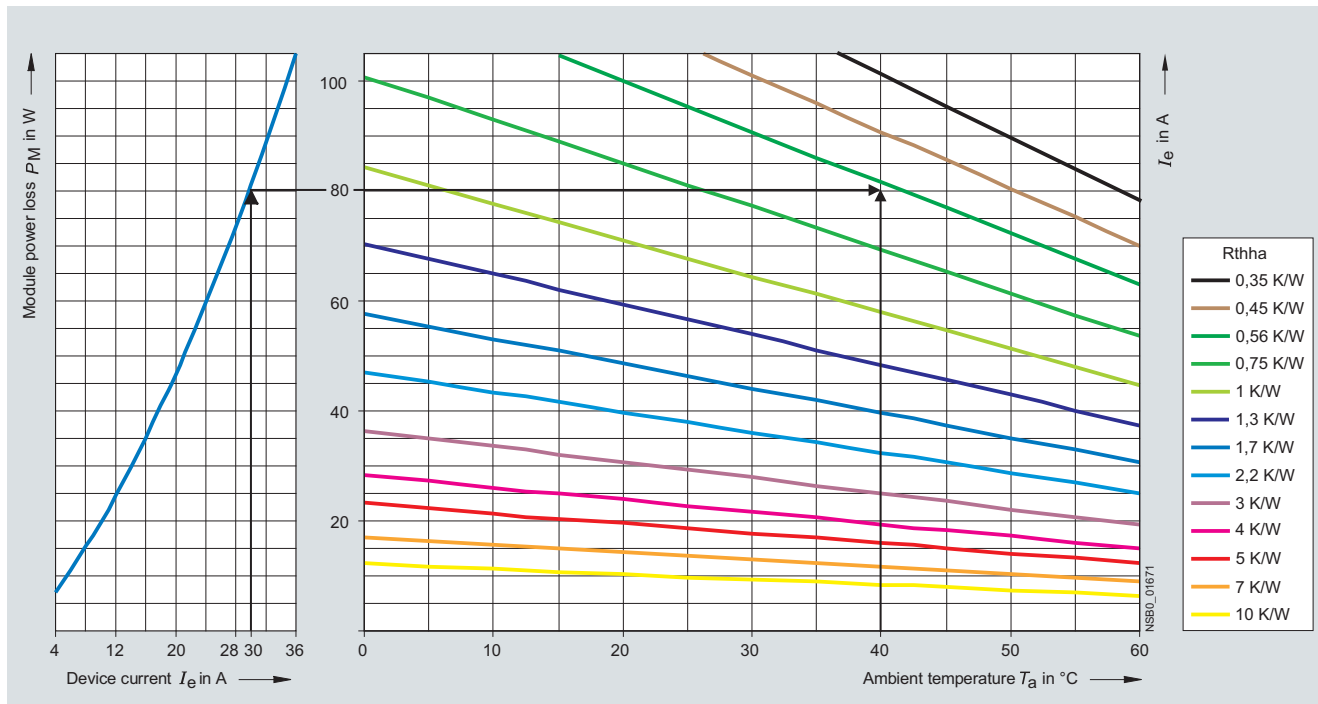

Type current 30 A (3RF22 30-.AB..)

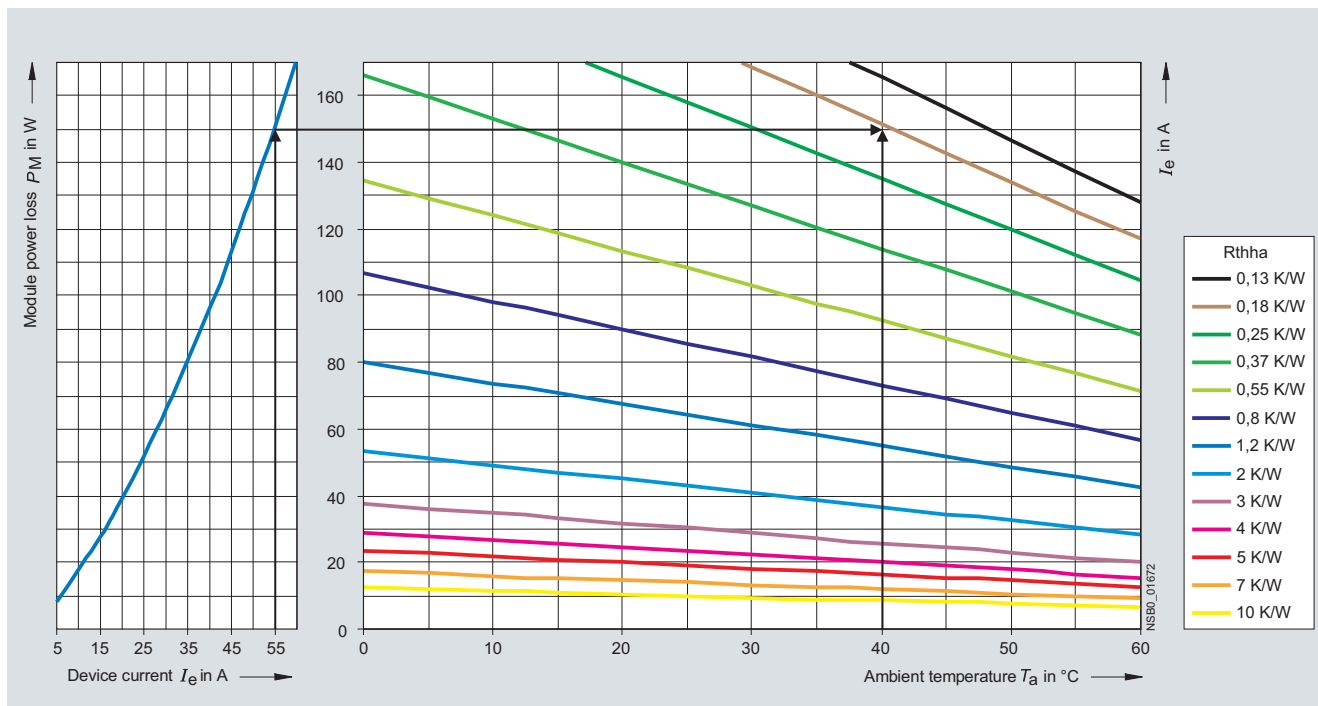

Type current 55 A (3RF22 55-.AB..)

4

Solid-State Switching Devices for Resistive Loads

Solid-State Relays

3RF22 solid-state relays, three-phase, 45 mm

Dependence of the device current I_e on the ambient temperature T_a and the heat sink resistance R_{thha} (three-phase controlled)

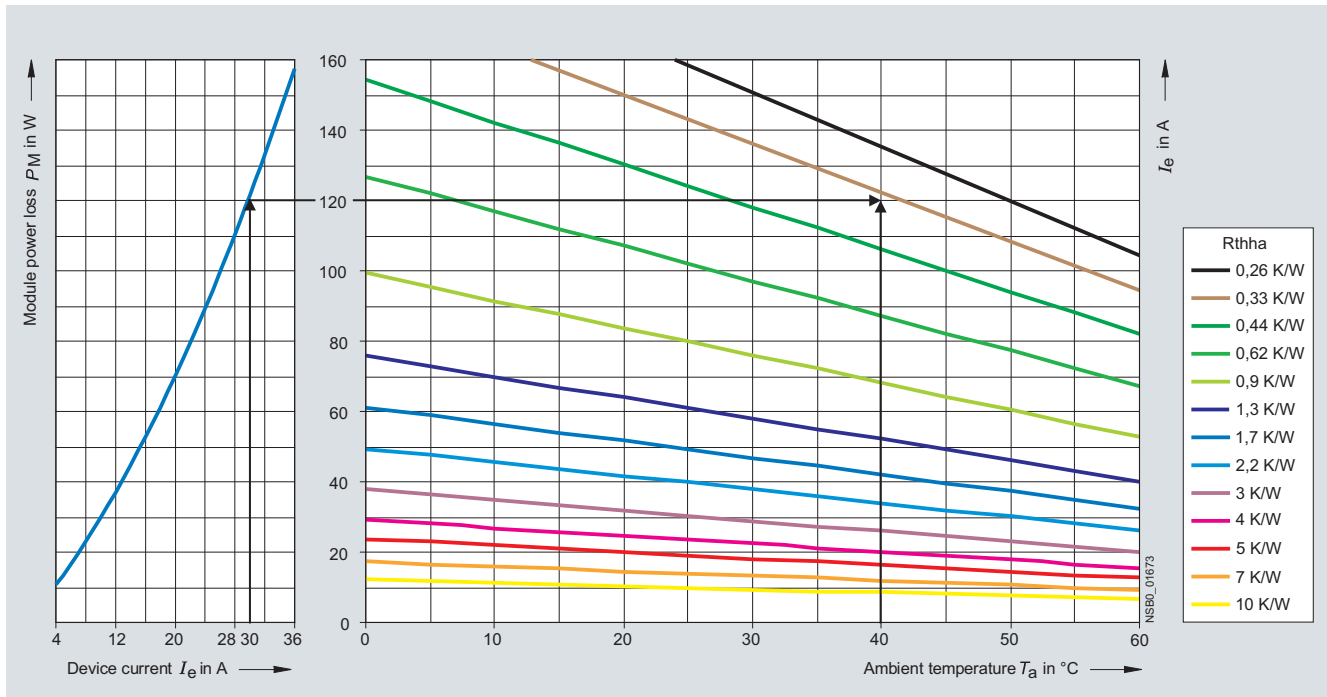

Type current 30 A (3RF22 30-.AC..)

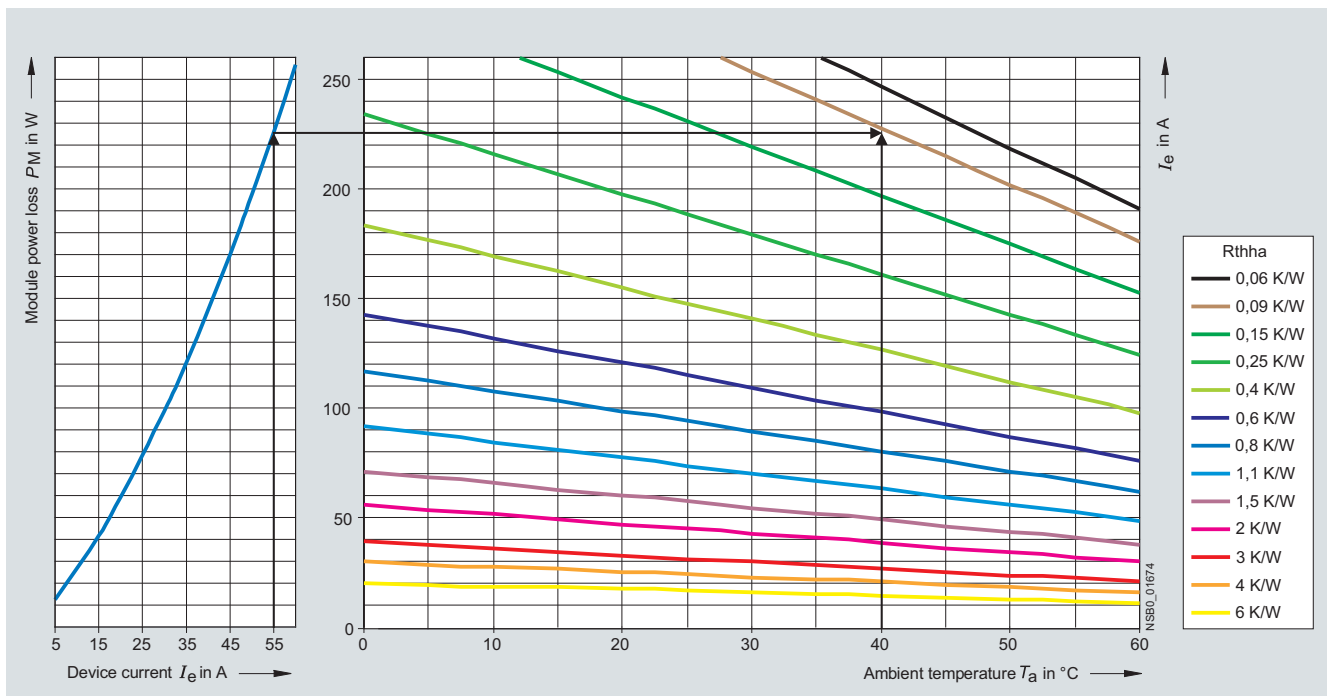

Type current 55 A (3RF22 55-.AC..)

Arrangement example

Given conditions: $I_e = 55$ A and $T_a = 40$ C. The task is to find the thermal resistance R_{thha} and the heat sink overtemperature dT_{ha} .

From the diagram on the left $\rightarrow P_M = 227$ W,
from the diagram on the right $\rightarrow R_{thha} = 0.09$ K/W.

This results in:

$$dT_{ha} = R_{thha} \times P_M = 0.09 \text{ K/W} \times 227 \text{ W} = 20.4 \text{ K.}$$

At $dT_{ha} = 20.4$ K the heat sink must therefore have an $R_{thha} = 0.09$ K/W.

Solid-State Switching Devices for Resistive Loads

Solid-State Relays

3RF22 solid-state relays, three-phase, 45 mm

Dimensional drawings

Solid-state relays

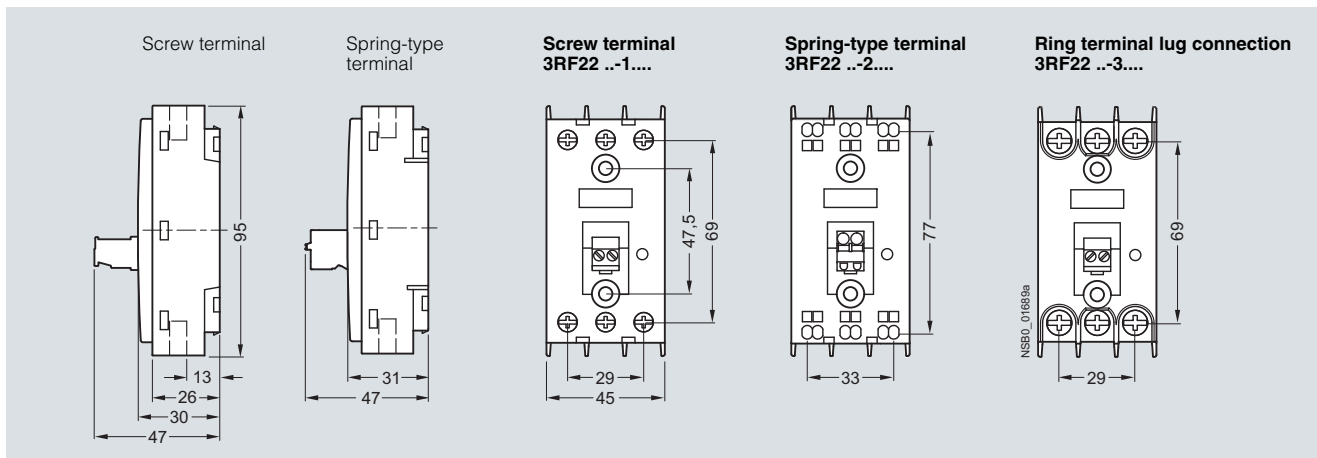

Schematics

Two-phase controlled,
DC control supply voltage

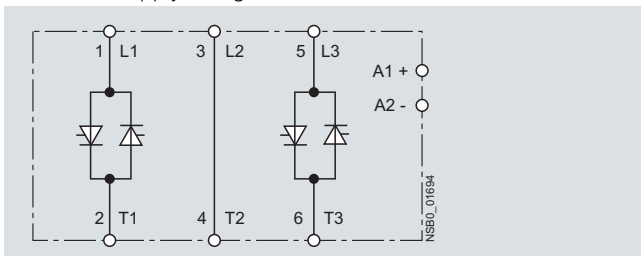

Three-phase controlled,
DC control supply voltage

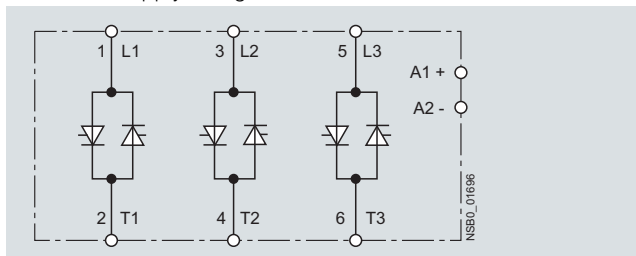

4

Solid-State Switching Devices for Resistive Loads

Solid-State Contactors

General data

Overview

The complete units consist of a solid-state relay plus optimized heat sink, and are therefore ready to use. They offer defined rated currents to make selection as easy as possible. Depending on the version, current strengths of up to 88 A are achieved. Like all of our solid-state switching devices, one of their particular advantages is their compact and space-saving design.

With their insulated mounting foot they can easily be snapped onto a standard mounting rail, or they can be mounted on support plates with fixing screws. This insulation enables them to be used in circuits with protective extra-low voltage (PELV) or safety extra-low voltage (SELV) in building management. For other applications, such as for extended personal safety, the heat sink can be grounded through a screw terminal.

The solid-state contactors are available in 2 different versions:

- 3RF23 single-phase solid-state contactors,
- 3RF24 three-phase solid-state contactors

Version for resistive loads, "zero-point switching"

This standard version is often used for switching space heaters on and off.

Version for inductive loads, "instantaneous switching"

In this version the solid-state contactor is specifically matched to inductive loads. Whether it is a matter of frequent actuation of the valves in a filling plant or starting and stopping small operating mechanisms in packet distribution systems, operation is carried out safely and noiselessly.

Special "Low noise" version

Thanks to a special control circuit, this zero-point-switching special version can be used in public networks up to 16 A without any additional measures such as interference suppressor filters. As a result it conforms to limit value curve class B according to EN 60947-4-3 in terms of emitted interference.

Special "Short-circuit resistant" version

Skillful matching of the zero-point switching power semiconductor with the performance of the solid-state contactor means that "short-circuit strength" can be achieved with a standard miniature circuit breaker. In combination with a B-type MCB or a conventional line protection fuse, the result is a short-circuit resistant feeder.

In order to achieve problem-free short-circuit protection by means of miniature circuit breakers, however, certain boundary conditions must be observed. As the magnitude and duration of the short-circuit current are determined not only by the short-circuit breaking response of the miniature circuit breaker but also the properties of the wiring system, such as the internal resistance of the input to the network and damping by controls and cables, particular attention must also be paid to these parameters. The necessary cable lengths are therefore shown for the main factor, the line resistance, in the table below.

The following miniature circuit breakers with a type B tripping characteristic and 10 kA or 6 kA breaking capacity protect the 3RF23...DA... solid-state contactors in the event of short-circuits on the load and the specified conductor cross-sections and lengths:

Rated current of the miniature circuit breaker	Example of type ¹⁾	Max. conductor cross-section	Minimum cable length from contactor to load
6 A	5SY4 106-6, 5SX2 106-6	1 mm ²	5 m
10 A	5SY4 110-6, 5SX2 110-6	1.5 mm ²	8 m
16 A	5SY4 116-6, 5SX2 116-6	1.5 mm ²	12 m
16 A	5SY4 116-6, 5SX2 116-6	2.5 mm ²	20 m
20 A	5SY4 120-6, 5SX2 120-6	2.5 mm ²	20 m
25 A	5SY4 125-6, 5SX2 125-6	2.5 mm ²	26 m

¹⁾ The miniature circuit breakers can be used up to a maximum rated voltage of 480 V!

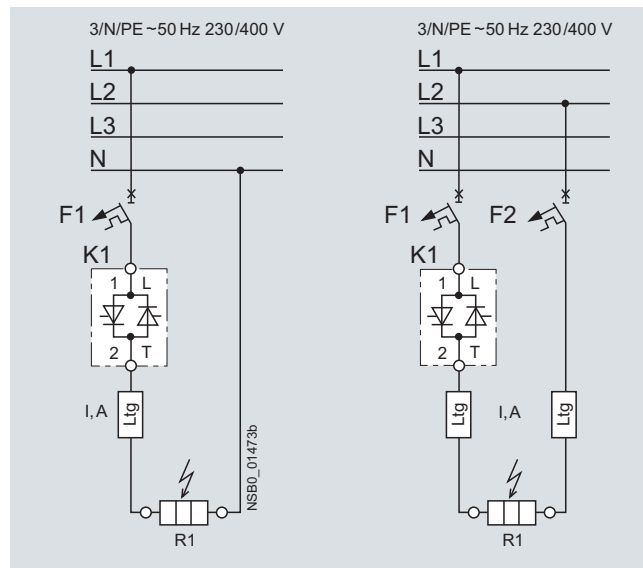

The setup and installation above can also be used for the solid-state relays with a I^2t value of at least 6600 A²s.

More information

Selecting solid-state contactors

The solid-state contactors are selected on the basis of details of the network, the load and the ambient conditions. As the solid-state contactors are already equipped with an optimally matched heat sink, the selection process is considerably simpler than that for solid-state relays.

The following procedure is recommended:

- Determine the rated current of the load and the mains voltage
- Select a solid-state contactor with the same or higher rated current than the load
- Check the correct contactor size with the aid of the rated current diagram, taking account of the installation conditions



Solid-State Switching Devices for Resistive Loads

Solid-State Contactors

3RF23 solid-state contactors, single-phase

Technical specifications

Order No.	3RF23 ...A...	3RF23 ...B...	3RF23 ...C...	3RF23 ...D...
General data				
Ambient temperature				
• During operation, derating from 40 °C	°C	-25 ... +60		
• During storage	°C	-55 ... +80		
Installation altitude	m	0 ... 1000; derating from 1000		
Shock resistance acc. to IEC 60068-2-27	g/ms	15/11		
Vibration resistance acc. to IEC 60068-2-6	g	2		
Degree of protection	IP20			
Electromagnetic compatibility (EMC)				
• Emitted interference acc. to IEC 60947-4-3 - Conducted interference voltage - Emitted, high-frequency interference voltage		Class A for industrial applications	Class A for industrial applications; Class B for residential/ business/ commercial applications up to 16 A, AC51 Low Noise	Class A for industrial applications
• Interference immunity - Electrostatic discharge acc. to IEC 61000-4-2 (corresponds to degree of severity 3) - Induced RF fields acc. to IEC 61000-4-6 - Burst acc. to IEC 61000-4-4 - Surge acc. to IEC 61000-4-5	kV MHz kV kV	Contact discharge 4; air discharge 8; behavior criterion 2 0.15 ... 80; 140 dBµV; behavior criterion 1 2/5.0 kHz; behavior criterion 1 Conductor - ground 2; conductor - conductor 1; behavior criterion 2		

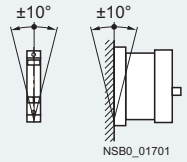
Order No.	3RF23 ...1....	3RF23 ...2....	3RF23 ...3....
General data			
Connection type	 Screw terminals	 Spring-type terminals	 Ring terminal lug connections
Connection, main contacts			
• Conductor cross-section	mm ²	2 x (1.5 ... 2.5) ¹⁾ , 2 x (2.5 ... 6) ¹⁾	2 x (0.5 ... 2.5)
- Solid	mm ²	2 x (1 ... 2.5) ¹⁾ , 2 x (2.5 ... 6) ¹⁾ , 1 x 10	2 x (0.5 ... 1.5)
- Finely stranded with end sleeve	mm ²	--	--
- Finely stranded without end sleeve	mm ²	2 x (AWG 14 ... 10)	2 x (0.5 ... 2.5)
- Solid or stranded, AWG cables		M4	2 x (AWG 18 ... 14)
• Terminal screw		--	M5
• Tightening torque	Nm lb.in	2 ... 2.5 7 ... 10.3	-- 2 ... 2.5 7 ... 10.3
• Cable lug		--	--
- DIN			DIN 46234 -5-2.5, -5-6, -5-10, -5-16, -5-25
- JIS			JIS C 2805 R 2-5, 5.5-5, 8-5, 14-5
Connection, auxiliary/control contacts			
• Conductor cross-section	mm AWG	1 x (0.5 ... 2.5) ¹⁾ , 2 x (0.5 ... 1.0) AWG 20 ... 12	0.5 ... 2.5 AWG 20 ... 12
• Stripped length	mm	7	10
• Terminal screw		M3	--
• Tightening torque	Nm lb.in	0.5 ... 0.6 4.5 ... 5.3	-- 0.5 ... 0.6 4.5 ... 5.3
Permissible mounting positions			
			

¹⁾ If two different conductor cross-sections are connected to one clamping point, both cross-sections must lie in the range specified. If identical cross-sections are used, this restriction does not apply.

Solid-State Switching Devices for Resistive Loads

Solid-State Contactors

3RF23 solid-state contactors, single-phase

Type		3RF23 ..-...2	3RF23 ..-...4	3RF23 ..-...5	3RF23 ..-...6
Main circuit					
Rated operational voltage U_e	V	24 ... 230	48 ... 460	48 ... 600	48 ... 600
• Operating range	V	20 ... 253	40 ... 506	40 ... 660	40 ... 660
• Rated frequency	Hz	50/60 ± 10 %			
Rated insulation voltage U_i	V	600			
Blocking voltage	V	800	1200		1600
Rate of voltage rise	V/μs	1000			

Type		3RF23 ..-...0.	3RF23 ..-...1.	3RF23 ..-...2.	3RF23 ..-...4.
Control circuit					
Method of operation		DC operation	AC/DC operation	AC operation	DC operation
Rated control supply voltage U_s	V	24 DC acc. to EN 61131-2	24 AC 24 DC	110 ... 230 AC	4 ... 30 DC
Rated frequency of the control supply voltage	Hz	--	50/60 ± 10 %	50/60 ± 10 %	--
Actuating voltage, max.	V	30	26.5 AC 30 DC	253	30
Typical actuating current	mA	20/Low Power: <10 ¹⁾		15	20
Response voltage	V	15	14 AC 15 DC	90	4
Drop-out voltage	V	5	5 AC 55 DC	40	1
Operating times					
• ON-delay	ms	1 + max. one half-wave ²⁾	10 + max. one half-wave ²⁾	40 + max. one half-wave ²⁾	1 + max. one half-wave ²⁾
• OFF-delay	ms	1 + max. one half-wave	15 + max. one half-wave	40 + max. one half-wave	1 + max. one half-wave

¹⁾ Applies to the version "Low Power" 3RF23 ..-AA...-OKN0.

²⁾ Only for zero-point-switching devices.

Solid-State Switching Devices for Resistive Loads

Solid-State Contactors

3RF23 solid-state contactors, single-phase

Order No.	Type current AC-51 ¹⁾			Power loss at I_{max}	Minimum load current	Leakage current	Rated impulse withstand capacity I_{tsm}	I^2t value	
	For I_{max} at 40 °C	Acc. to IEC 60947-4-3 for 40 °C	Acc. to UL/CSA for 50 °C						
	A	A	A	W	A	mA	A	A ² s	
Main circuit									
3RF23 1.-.A..2	10.5	7.5	9.6	11	0.1	10	200	200	
3RF23 1.-.A..4							200	200	
3RF23 1.-.A..5							200	200	
3RF23 1.-.A..6							400	800	
3RF23 2.-.A..2	20	13.2	17.6	20	0.5	10	600	1800	
3RF23 2.-.A..4							600	1800	
3RF23 2.-.A..5							600	1800	
3RF23 2.-.A..6							600	1800	
3RF23 2.-.C..2							25	600	1800
3RF23 2.-.C..4							25	600	1800
3RF23 2.-.D..2							10	1150	6600
3RF23 2.-.D..4							10	1150	6600
3RF23 3.-.A..2	30	22	27	33	0.5	10	600	1800	
3RF23 3.-.A..4							600	1800	
3RF23 3.-.A..5							600	1800	
3RF23 3.-.A..6							600	1800	
3RF23 3.-.C..2							25	600	1800
3RF23 3.-.D..4							10	1150	6600
3RF23 4.-.A..2	40	33	36	44	0.5	10	1200	7200	
3RF23 4.-.A..4							1200	7200	
3RF23 4.-.A..5							1200	7200	
3RF23 4.-.A..6							1150	6600	
3RF23 5.-.A..2	50	36	45	54	0.5	10	1150	6600	
3RF23 5.-.A..4									
3RF23 5.-.A..5									
3RF23 5.-.A..6									
3RF23 7.-.A..2	70	70	62	83	0.5	10	1150	6600	
3RF23 7.-.A..4									
3RF23 7.-.A..5									
3RF23 7.-.A..6									
3RF23 9.-.A..2	88	88	80	117	0.5	10	1150	6600	
3RF23 9.-.A..4									
3RF23 9.-.A..5									
3RF23 9.-.A..6									

¹⁾ The type current provides information about the performance of the solid-state contactor. The actual permitted rated operational current I_e can be smaller depending on the connection method and start-up conditions.
For derating see the characteristic curves on page 4/28.

Order No.	Type current AC-51 ¹⁾			Type current AC-15		Power loss at I_{max}	Minimum load current	Leakage current	Rated impulse withstand capacity I_{tsm}	I^2t value
	For I_{max} at 40 °C	Acc. to IEC 60947-4-3 for 40 °C	Acc. to UL/CSA for 50 °C	10 x I_e for 60 ms	Parameters					
	A	A	A	A		W	A	mA	A	A ² s
Main circuit										
3RF23 1.-.B..2	10.5	7.5	9.6	6	1200 1/h 50 % ON period	11	0.1	10	200	200
3RF23 1.-.B..4									200	200
3RF23 1.-.B..6									400	800
3RF23 2.-.B..2	20	13.2	17.6	12	1200 1/h 50 % ON period	20	0.5	10	600	1800
3RF23 2.-.B..4										
3RF23 2.-.B..6										
3RF23 3.-.B..2	30	22	27	15	1200 1/h 50 % ON period	33	0.5	10	600	1800
3RF23 3.-.B..4										
3RF23 3.-.B..6										
3RF23 4.-.B..2	40	33	36	20	1200 1/h 50 % ON period	44	0.5	10	1200	7200
3RF23 4.-.B..4									1200	7200
3RF23 4.-.B..6									1150	6600
3RF23 5.-.B..2	50	36	45	25	1200 1/h 50 % ON period	54	0.5	10	1150	6600
3RF23 5.-.B..4										
3RF23 5.-.B..6										
3RF23 7.-.B..2	70	70	62	27.5	1200 1/h 50 % ON period	83	0.5	10	1150	6600
3RF23 7.-.B..4										
3RF23 7.-.B..6										
3RF23 9.-.B..2	88	88	80	30	1200 1/h 50 % ON period	117	0.5	10	1150	6600
3RF23 9.-.B..4										
3RF23 9.-.B..6										

¹⁾ The type current provides information about the performance of the solid-state contactor. The actual permitted rated operational current I_e can be smaller depending on the connection method and start-up conditions.
For derating see the characteristic curves on page 4/28.

Solid-State Switching Devices for Resistive Loads

Solid-State Contactors

3RF23 solid-state contactors, single-phase

Fused version with semiconductor protection (similar to type of coordination "2")¹⁾

The semiconductor protection for the SIRIUS controls can be used with different protective devices. This allows protection by means of LV HRC fuses of gG operational class or miniature circuit breakers. Siemens recommends the use of special SITOR semiconductor fuses. The table below lists the maximum permissible fuses for each SIRIUS control.

If a fuse is used with a higher rated current than specified, semiconductor protection is no longer guaranteed. However, smaller fuses with a lower rated current for the load can be used without problems.

For protective devices with gG operational class and for SITOR 3NE1 all-range fuses, the minimum cross-sections for the conductor to be connected must be taken into account.

Order No.	All-range fuses		Semiconductor fuses/partial-range fuses			
	LV HRC design	Cylindrical design	LV HRC design	Cylindrical design		
	gR/SITOR	gR/NEOZED ²⁾	aR/SITOR	aR/SITOR	aR/SITOR	aR/SITOR
	3NE1	SILIZED 5SE1	3NE8	10 mm x 38 mm 3NC1 0	14 mm x 51 mm 3NC1 4	22 mm x 58 mm 3NC2 2
3RF23 1.-.....	3NE1813-0	5SE1 316	3NE8 015-1	3NC1 010	3NC1 410	3NC2 220
3RF23 2.-.....	3NE1814-0	5SE1 325	3NE8 015-1	3NC1 020	3NC1 420	3NC2 220
3RF23 3.-.....	3NE1803-0	5SE1 335	3NE8 003-1	3NC1 032	3NC1 432	3NC2 232
3RF23 4.-.....	3NE1802-0	5SE1 350	3NE8 017-1	--	3NC1 440	3NC2 240
3RF23 5.-.....	3NE1817-0	5SE1 363	3NE8 018-1	--	3NC1 450	3NC2 250
3RF23 7.-.....2	3NE1820-0	--	3NE8 020-1	--	--	3NC2 280
3RF23 7.-.....4	3NE1020-2	--	3NE8 020-1	--	--	3NC2 280
3RF23 7.-.....5³⁾	3NE1020-2	--	3NE8 020-1	--	--	3NC2 280
3RF23 7.-.....6	3NE1020-2	--	3NE8 020-1	--	--	3NC2 280
3RF23 9.-.....2	3NE1021-2	--	3NE8 021-1	--	--	3NC2 200
3RF23 9.-.....4	3NE1021-2	--	3NE8 021-1	--	--	3NC2 280 ⁴⁾
3RF23 9.-.....5³⁾	3NE1021-2	--	3NE8 021-1	--	--	3NC2 280 ⁴⁾
3RF23 9.-.....6	3NE1020-2 ⁴⁾	--	3NE8 021-1	--	--	3NC2 280 ⁴⁾

Order No.	Cable and line protection fuses				
	LV HRC design	Cylindrical design	gG		DIAZED
	gG	gG	gG	gG	quick
	3NA6	10 mm x 38 mm 3NW6 0	14 mm x 51 mm 3NW6 1	22 mm x 58 mm 3NW6 2	5SB
3RF23 1.-.....2	3NA6 803	3NW6 001-1 ⁴⁾	3NW6 101-1 ⁴⁾	--	5SB1 41
3RF23 1.-.....4	3NA6 801	3NW6 001-1 ⁴⁾	3NW6 101-1 ⁴⁾	--	5SB1 41
3RF23 1.-.....5³⁾	3NA6 801	3NW6 001-1 ⁴⁾	3NW6 101-1 ³⁾	--	5SB1 41
3RF23 1.-.....6	3NA6 803-6	--	--	--	--
3RF23 2.-.....2	3NA6 807	3NW6 007-1 ⁴⁾	3NW6 107-1	3NW6 207-1	5SB1 71
3RF23 2.-.....4	3NA6 807	3NW6 005-1 ⁴⁾	3NW6 105-1 ⁴⁾	3NW6 205-1 ⁴⁾	5SB1 71
3RF23 2.-.....5³⁾	3NA6 807	3NW6 005-1 ⁴⁾	3NW6 105-1 ⁴⁾	3NW6 205-1 ⁴⁾	5SB1 71
3RF23 2.-.....6	3NA6 807-6	--	--	--	--
3RF23 3.-.....2	3NA6 810 ⁴⁾	--	3NW6 107-1 ⁴⁾	3NW6 207-1	5SB3 11
3RF23 3.-.....4	3NA6 807 ⁴⁾	--	3NW6 105-1 ⁴⁾	3NW6 205-1 ⁴⁾	5SB3 11
3RF23 3.-.....5³⁾	3NA6 807 ⁴⁾	--	3NW6 105-1 ⁴⁾	3NW6 205-1 ⁴⁾	5SB3 11
3RF23 3.-.....6	3NA6 807-6 ⁴⁾	--	--	--	--
3RF23 4.-.....2	3NA6 817	--	3NW6 117-1	3NW6 217-1	5SB3 21
3RF23 4.-.....4	3NA6 812 ⁴⁾	--	3NW6 112-1 ⁴⁾	3NW6 212-1 ⁴⁾	5SB3 21
3RF23 4.-.....5³⁾	3NA6 812 ⁴⁾	--	3NW6 112-1 ⁴⁾	3NW6 212-1 ⁴⁾	5SB3 21
3RF23 4.-.....6	--	--	--	--	--
3RF23 5.-.....2	--	--	--	3NW6 217-1 ⁴⁾	5SB3 21
3RF23 5.-.....4	--	--	--	--	5SB3 21
3RF23 5.-.....5³⁾	--	--	--	--	5SB3 21
3RF23 5.-.....6	--	--	--	--	--
3RF23 7.-.....2	--	--	--	--	5SB3 21 ⁴⁾
3RF23 7.-.....4	--	--	--	--	5SB3 21 ⁴⁾
3RF23 7.-.....5³⁾	--	--	--	--	5SB3 21 ⁴⁾
3RF23 7.-.....6	--	--	--	--	--
3RF23 9.-.....2	--	--	--	--	5SB3 31 ⁴⁾
3RF23 9.-.....4	--	--	--	--	5SB3 21 ⁴⁾
3RF23 9.-.....5³⁾	--	--	--	--	5SB3 21 ⁴⁾
3RF23 9.-.....6	--	--	--	--	--

Suitable fuse holders, fuse bases and controls can be found in Catalog LV 1, Chapter 19.

- 1) Type of coordination "2" according to EN 60947-4-1:
In the event of a short-circuit, the controls in the load feeder must not endanger persons or the installation. They must be suitable for further operation. For fused configurations, the protective device must be replaced.
- 2) For use only with operational voltage U_e up to 400 V.
- 3) For use only with operational voltage U_e up to 506 V.
- 4) These fuses have a smaller rated current than the solid-state contactors.

Solid-State Switching Devices for Resistive Loads

Solid-State Contactors

3RF23 solid-state contactors, single-phase

Characteristic curves

Derating curves

For designation of the characteristic curves see page 4/30.

4

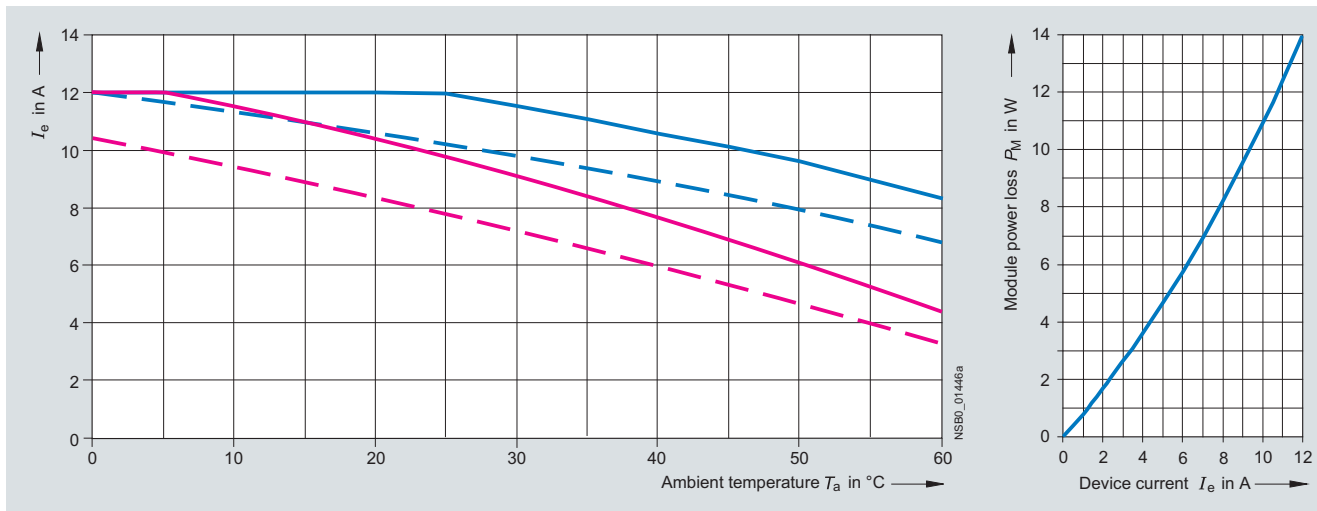

Type current 10.5 A (3RF23 10)

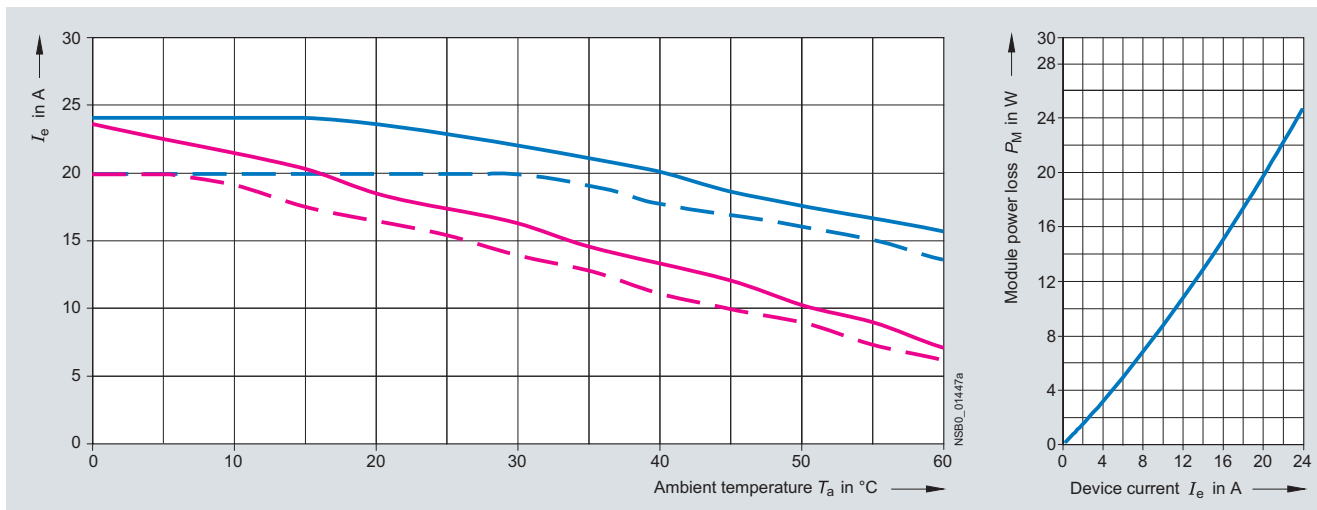

Type current 20 A (3RF23 20)

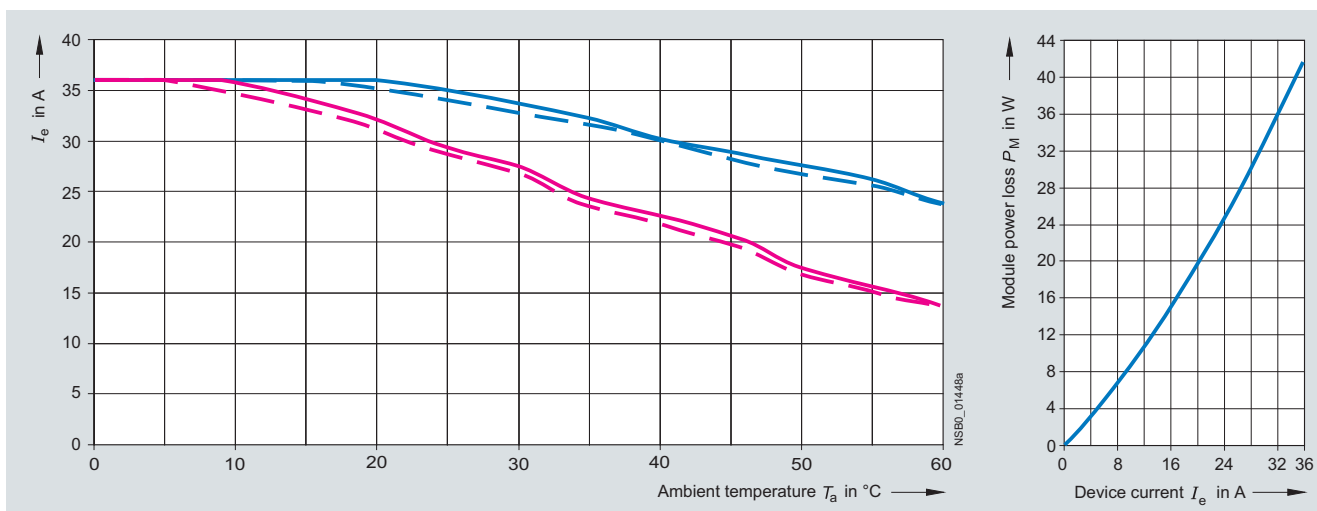

Type current 30 A (3RF23 30-AA.., -BA.., -CA..)

Solid-State Switching Devices for Resistive Loads

Solid-State Contactors

3RF23 solid-state contactors, single-phase

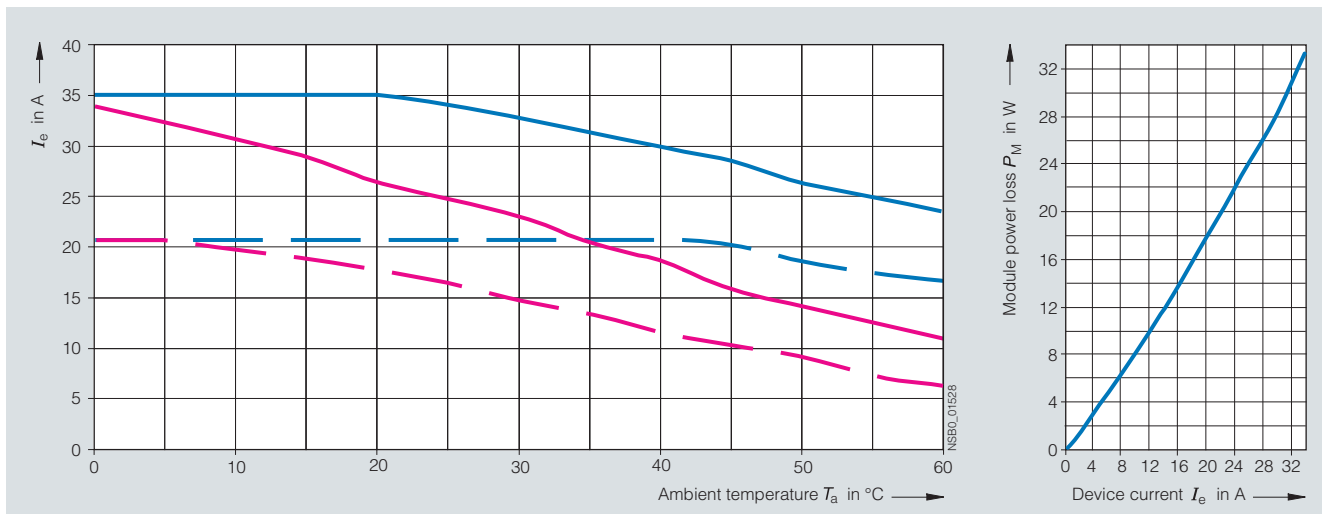

Type current 30 A (3RF23 30-DA..)

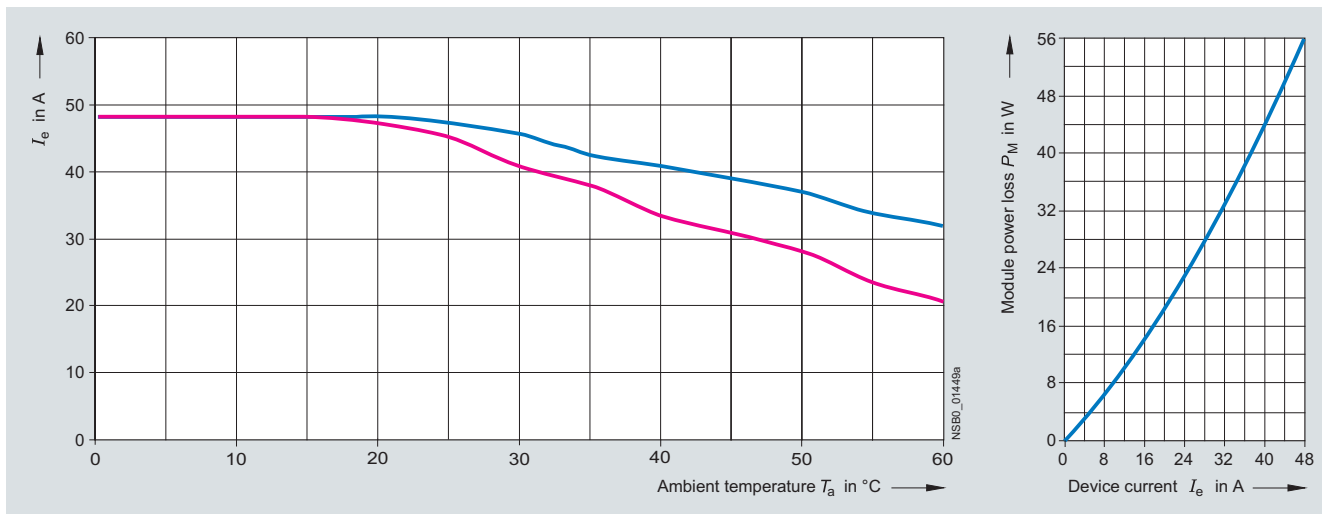

Type current 40 A (3RF23 40)¹⁾

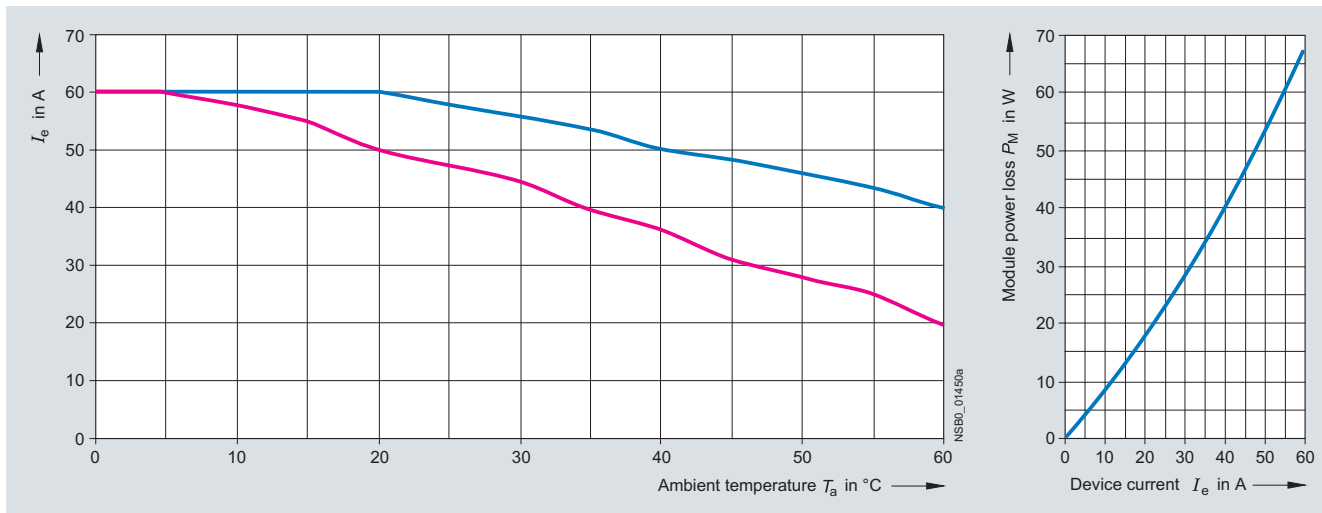

Type current 50 A (3RF23 50)¹⁾

- I_{max} Thermal limit current for individual mounting
- - I_{max} Thermal limit current for side-by-side mounting
- I_{IEC} Current acc. to IEC 947-4-3 for individual mounting
- - I_{IEC} Current acc. to IEC 947-4-3 for side-by-side mounting

Note: When loaded with IIEC, the maximum overtemperature at the heat sink is 50 K.

¹⁾ Identical current/temperature curves for stand-alone and side-by-side installation.

Solid-State Switching Devices for Resistive Loads

Solid-State Contactors

3RF23 solid-state contactors, single-phase

4

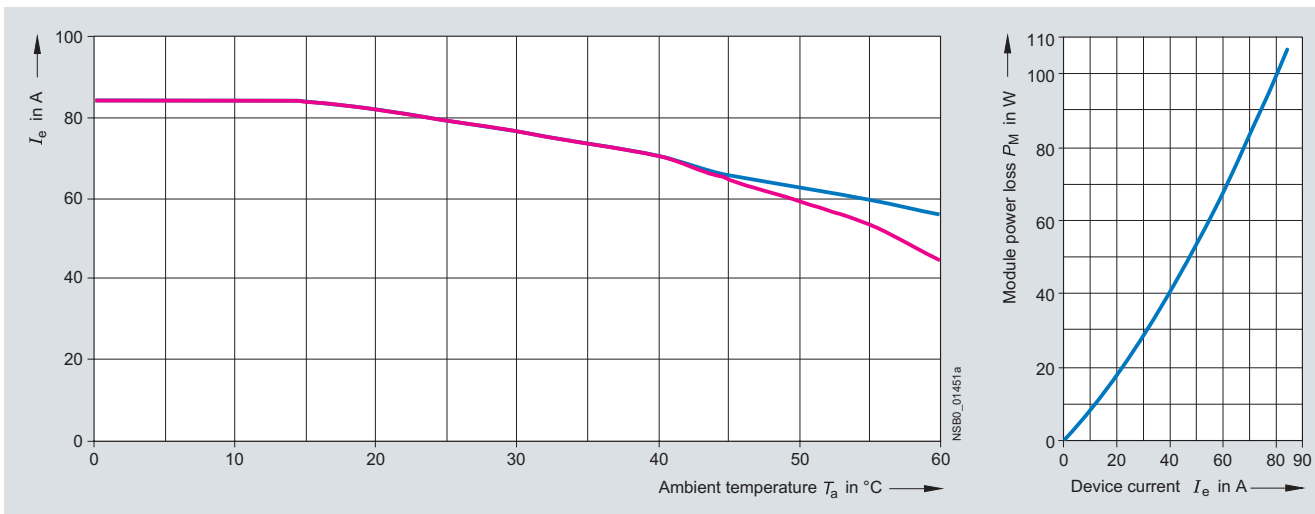

Type current 70 A (3RF23 70)¹⁾

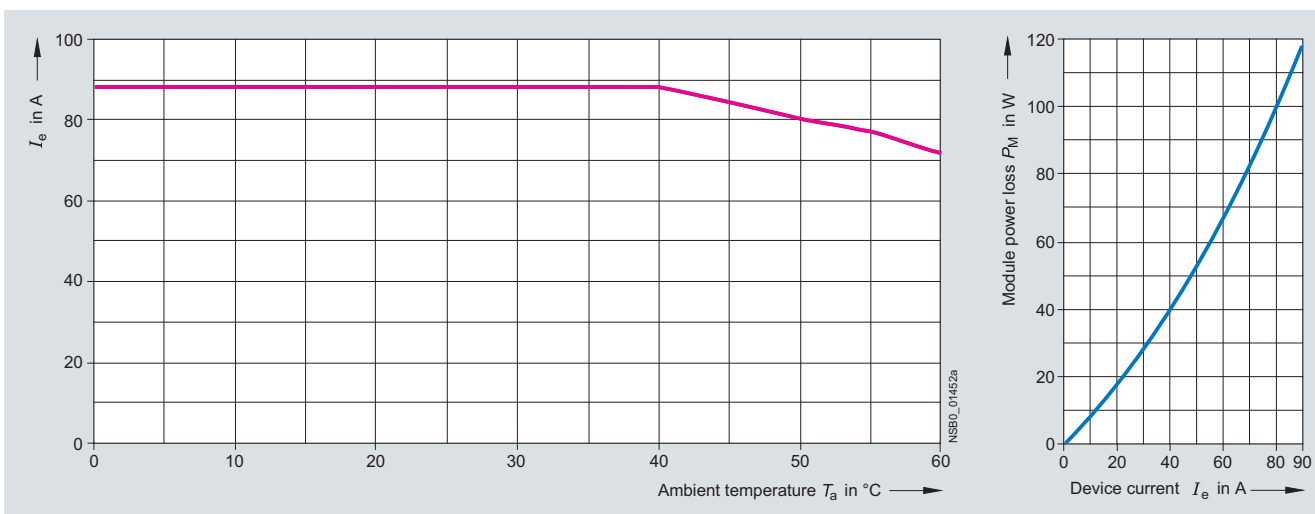

Type current 88 A (3RF23 90)¹⁾²⁾

- I_{max} Thermal limit current for individual mounting
- - - I_{max} Thermal limit current for side-by-side mounting
- I_{IEC} Current acc. to IEC 947-4-3 for individual mounting
- - - I_{IEC} Current acc. to IEC 947-4-3 for side-by-side mounting

Note: When loaded with IIEC, the maximum overtemperature at the heat sink is 50 K.

Mounting regulations

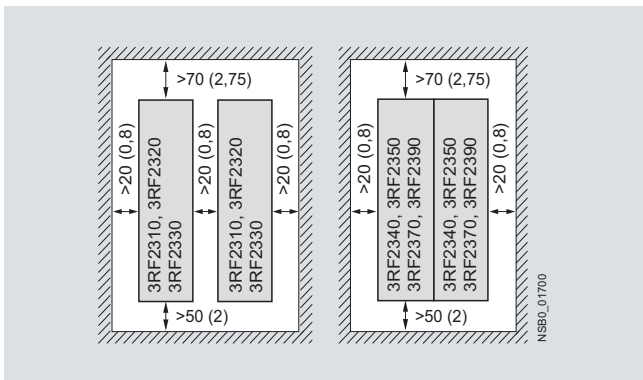

Clearances for stand-alone and side-by-side installation

1) Identical current/temperature curves for stand-alone and side-by-side installation.
 2) I_{max} and I_{IEC} have identical curves.

Solid-State Switching Devices for Resistive Loads

Solid-State Contactors

3RF23 solid-state contactors, single-phase

Dimensional drawings

Type current 10.5 A and 20 A

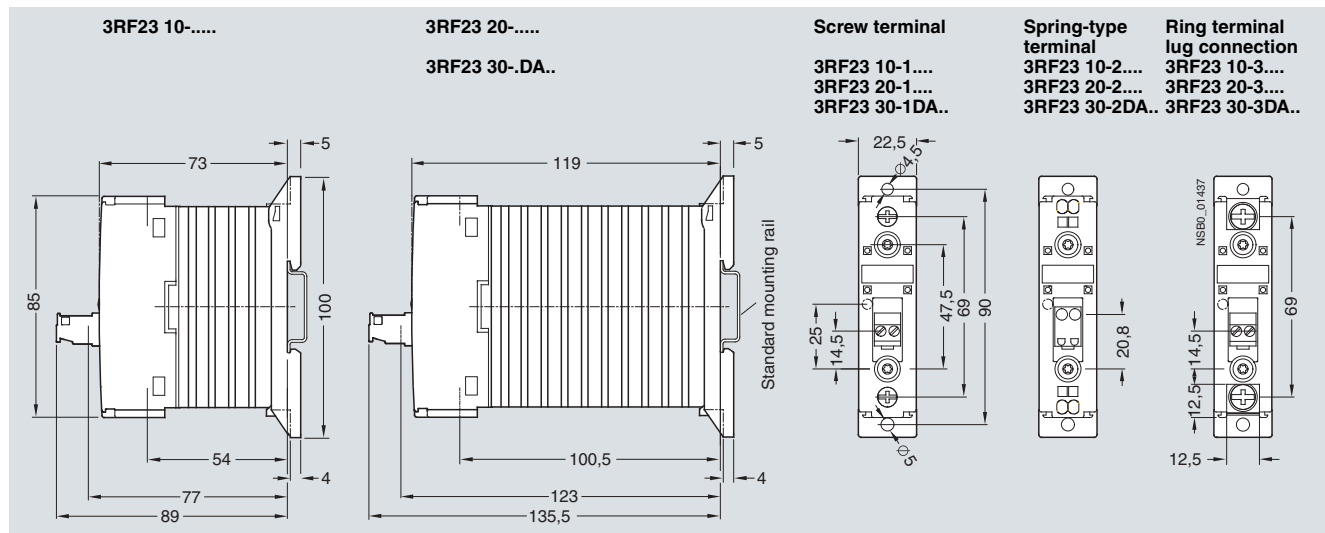

Type current 30 A

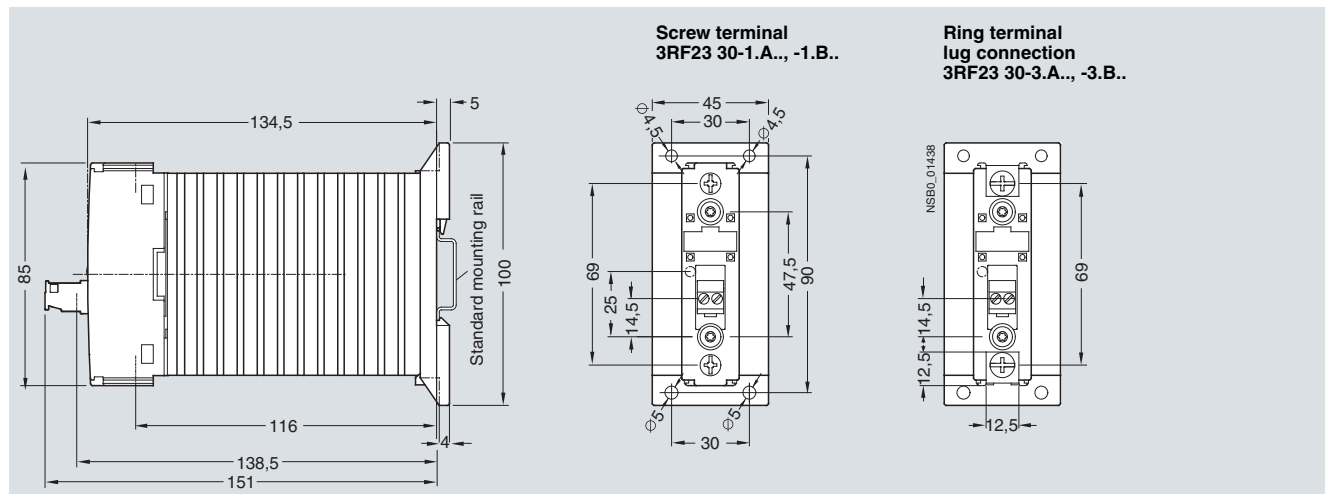

Type current 40 A and 50 A

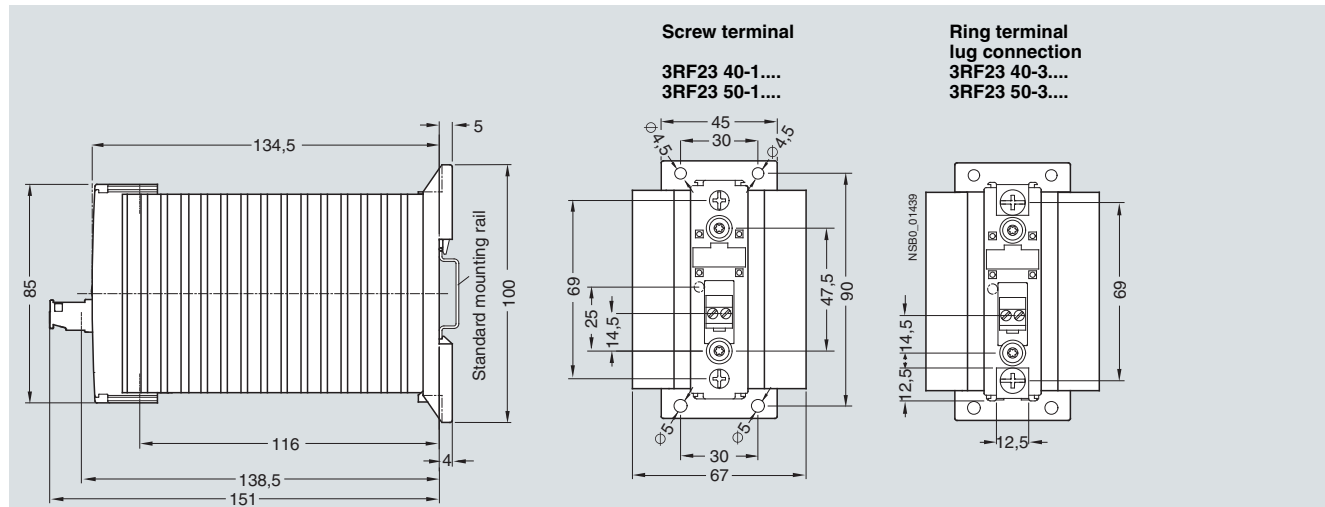

Solid-State Switching Devices for Resistive Loads

Solid-State Contactors

3RF23 solid-state contactors, single-phase

Type current 70 A

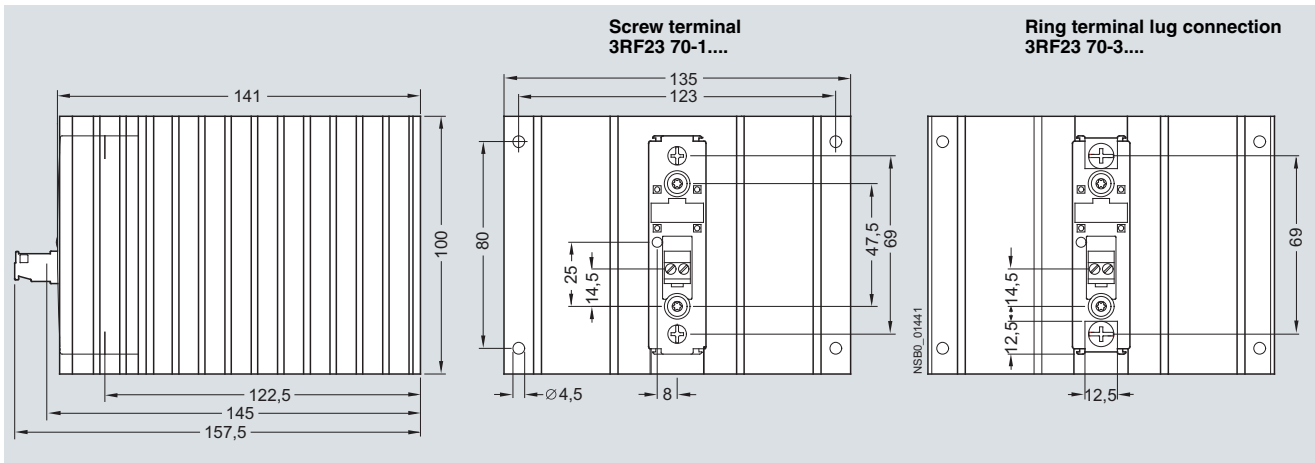

Type current 88 A

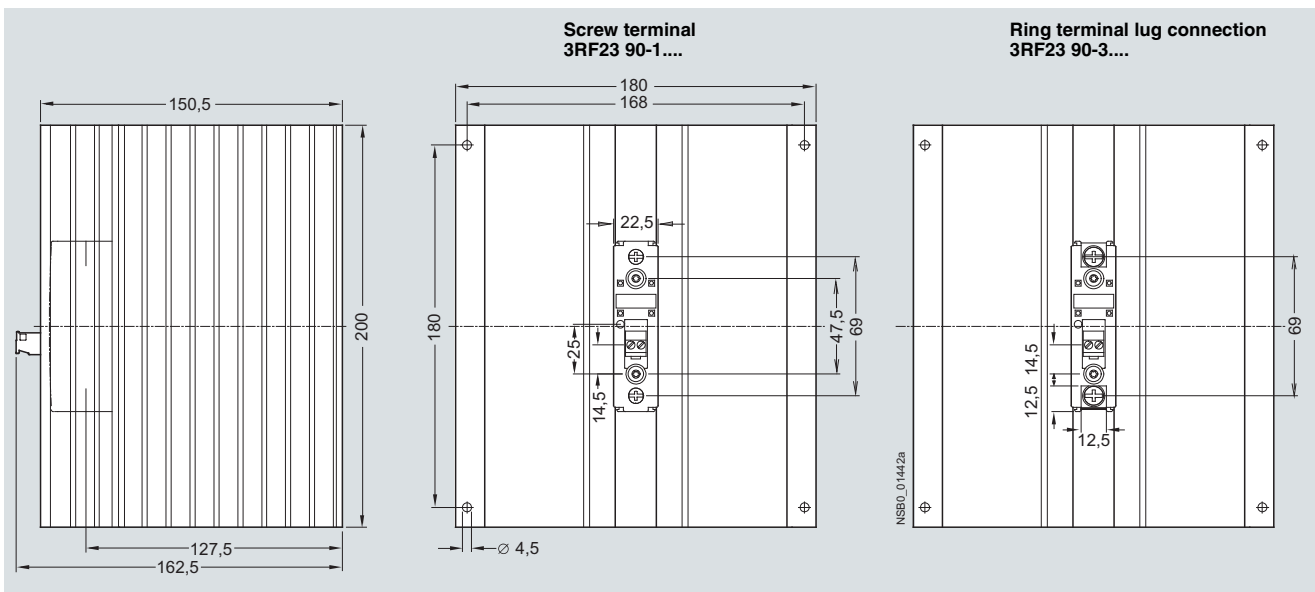

Terminal cover

3RF29 00-3PA88

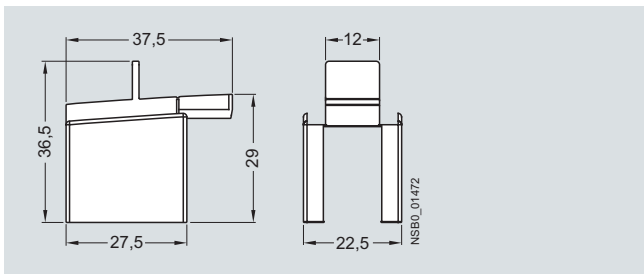

Schematics

Version DC control supply voltage

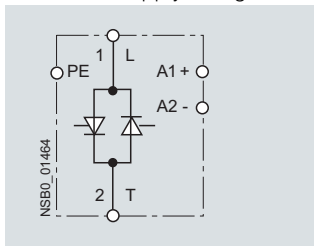

Version AC control supply voltage

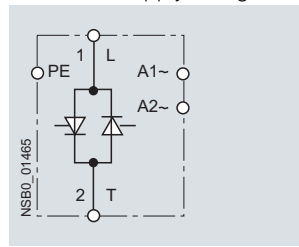



Solid-State Switching Devices for Resistive Loads

Solid-State Contactors

3RF24 solid-state contactors, three-phase

Technical specifications

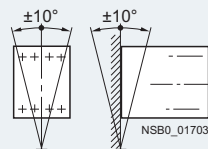
Order No.	3RF24 ..-1....	3RF24 ..-2....	3RF24 ..-3....
General data			
Ambient temperature			
• During operation, derating from 40 °C	°C	-25 ... +60	
• During storage	°C	-55 ... +80	
Installation altitude	m	0 ... 1000; derating from 1000	
Shock resistance acc. to IEC 60068-2-27	g/ms	15/11	
Vibration resistance acc. to IEC 60068-2-6	g	2	
Degree of protection		IP20	
Insulation strength at 50/60 Hz (main/control circuit to floor)	V rms	4000	
Electromagnetic compatibility (EMC)			
• Emitted interference acc. to IEC 60947-4-3 - Conducted interference voltage - Emitted, high-frequency interference voltage		Class A for industrial applications ¹⁾ Class A for industrial applications	
• Interference immunity - Electrostatic discharge acc. to IEC 61000-4-2 (corresponds to degree of severity 3)	kV	Contact discharge 4; air discharge 8; behavior criterion 2	
- Induced RF fields acc. to IEC 61000-4-6	MHz	0.15 ... 80; 140 dBµV; behavior criterion 1	
- Burst acc. to IEC 61000-4-4	kV	2/5.0 kHz; behavior criterion 1	
- Surge acc. to IEC 61000-4-5	kV	Conductor - ground 2; conductor - conductor 1; behavior criterion 2	
Connection type		 Screw terminals	 Spring-type terminals
Connection, main contacts			 Ring terminal lug connections
• Conductor cross-section	mm ²	2 x (1.5 ... 2.5) ²⁾ , 2 x (2.5 ... 6) ²⁾	2x (0.5 ... 2.5)
- Solid	mm ²	2 x (1 ... 2.5) ²⁾ , 2 x (2.5 ... 6) ²⁾ , 1 x 10	2x (0.5 ... 1.5)
- Finely stranded with end sleeve	mm ²	--	--
- Finely stranded without end sleeve	mm ²	2 x (AWG 14 ... 10)	2x (0.5 ... 2.5)
- Solid or stranded, AWG cables	mm	10	2x (AWG 18 ... 14)
• Stripped length	mm	10	10
• Terminal screw		M4	--
- Tightening torque	Nm	2 ... 2.5	M5
	lb.in	18 ... 22	2 ... 2.5
			18 ... 22
• Cable lug		--	--
- Acc. to DIN 46234			5-2.5 ... 5-25
- Acc. to JIS C 2805			R 2-5 ... 14-5
Connection, auxiliary/control contacts			
• Conductor cross-section	mm	1 x (0.5 ... 2.5), 2 x (0.5 ... 1.0)	0.5 ... 2.5
	AWG	AWG 20 ... 12	AWG 20 ... 12
• Stripped length	mm	7	10
• Terminal screw		M3	--
- Tightening torque,	Nm	0.5 ... 0.6	M3
∅ 3.5, PZ 1	lb.in	4.5 ... 5.3	0.5 ... 0.6
			4.5 ... 5.3
Permissible mounting positions			

¹⁾ These products were built as Class A devices. The use of these devices in residential areas could result in lead in radio interference. In this case these may be required to introduce additional interference suppression measures.

²⁾ If two different conductor cross-sections are connected to one clamping point, both cross-sections must lie in the range specified. If identical cross-sections are used, this restriction does not apply.

Solid-State Switching Devices for Resistive Loads

Solid-State Contactors

3RF24 solid-state contactors, three-phase

Order No.	Type current I_{AC-51} at 40 °C	Rated operational current I_e Acc. to IEC 60947-4-3 for 40 °C	Rated operational current I_e Acc. to UL/CSA for 50 °C	Power loss at I_{AC-51}	Minimum load current	Max. leakage current	Rated impulse withstand capacity I_{tsm}	I^2t value
	A	A	A	W	A	mA	A	A ² s
Main circuit								
3RF24 10-.AB.5	10.5	7	7	23	0.1	10	200	200
3RF24 20-.AB.5	22	15	15	44	0.5	10	600	1800
3RF24 30-.AB.5	30	22	22	61	0.5	10	1200	7200
3RF24 40-.AB.5	40	30	30	80	0.5	10	1150	6600
3RF24 50-.AB.5	50	38	38	107	0.5	10	1150	6600
3RF24 10-.AC.5	10.5	7	7	31	0.1	10	300	450
3RF24 20-.AC.5	22	15	15	66	0.5	10	600	1800
3RF24 30-.AC.5	30	22	22	91	0.5	10	1200	7200
3RF24 40-.AC.5	40	30	30	121	0.5	10	1150	6600
3RF24 50-.AC.5	50	38	38	160	0.5	10	1150	6600

1) The type current provides information about the performance of the solid-state contactor. The actual permitted rated operational current I_e can be smaller depending on the connection method and start-up conditions. For derating see the characteristic curves on page 4/36.

Type		3RF24 ..-.AB.5	3RF24 ..-.AC.5
Main circuit			
Controlled phases		Two-phase	Three-phase
Rated operational voltage U_e	V	48 ... 600	48 ... 600
• Operating range	V	40 ... 660	40 ... 660
• Rated frequency	Hz	50/60 ± 10 %	50/60 ± 10 %
Rated insulation voltage U_i	V	600	600
Rated impulse withstand voltage U_{imp}	kV	6	6
Blocking voltage	V	1200	1200
Rate of voltage rise	V/μs	1000	1000

Type		3RF24 ..-...3.	3RF24 ..-...4.	3RF24 ..-...5.
Control circuit				
Method of operation		AC operation	DC operation	AC operation
Rated control supply voltage U_s	V	110	4 ... 30	190 ... 230
Rated frequency of the control supply voltage	Hz	50/60 ± 10 %	--	50/60 ± 10 %
Actuating voltage, max.	V	121	30	253
Typical actuating current	mA	15	30	15
Response voltage	V	90	4	180
Drop-out voltage	V	< 40	< 1	< 40
Operating times				
• ON-delay	ms	40 + max. one half-wave	1 + max. one half-wave	40 + max. one half-wave
• OFF-delay	ms	40 + max. one half-wave	1 + max. one half-wave	40 + max. one half-wave

Solid-State Switching Devices for Resistive Loads

Solid-State Contactors

3RF24 solid-state contactors, three-phase

Fused version with semiconductor protection (similar to type of coordination "2")¹⁾

The semiconductor protection for the 3RF24 controls can be used with different protective devices. Siemens recommends the use of special SITOR semiconductor fuses. The table below lists the maximum permissible fuses for each 3RF24 control.

If a fuse is used with a higher rated current than specified, semiconductor protection is no longer guaranteed. However, smaller fuses with a lower rated current for the load can be used without problems.

Order No.	All-range fuses		Semiconductor fuses/partial-range fuses			
	LV HRC design gR/SITOR	Cylindrical design gR/NEOZED ²⁾	LV HRC design aR/SITOR	Cylindrical design		aR/SITOR
	3NE1	SILIZED 5SE1	3NE8	10 mm x 38 mm 3NC1 0	14 mm x 51 mm 3NC1 4	22 mm x 58 mm 3NC2 2

Operational voltage U_e up to 460 V (+10 %)						
3RF24 10-A...	3NE1 813-0	5SE1 310	3NE8 015-1	3NC1 012	3NC1 415	3NC2 220
3RF24 20-A...	3NE1 814-0	5SE1 320	3NE8 015-1	3NC1 025	3NC1 425	3NC2 225
3RF24 30-A...	3NE1 803-0	5SE1 335	3NE8 003-1	3NC1 032	3NC1 432	3NC2 232
3RF24 40-A...	3NE1 802-0	5SE1 350	3NE8 017-1	--	3NC1 450	3NC2 250
3RF24 50-A...	3NE1 817-0	5SE1 350	3NE8 018-1	--	3NC1 450	3NC2 263

Operational voltage U_e up to 600 V (+10 %)						
3RF24 10-A...	3NE1 813-0	--	3NE8 015-1	3NC1 012	3NC1 415	3NC2 220
3RF24 20-A...	3NE1 814-0	--	3NE8 015-1	3NC1 025	3NC1 425	3NC2 225
3RF24 30-A...	3NE1 803-0	--	3NE8 003-1	3NC1 032	3NC1 432	3NC2 232
3RF24 40-A...	3NE1 802-0	--	3NE8 017-1	--	3NC1 450	3NC2 250
3RF24 50-A...	3NE1 817-0	--	3NE8 018-1	--	3NC1 450	3NC2 263

Order No.	Cable and line protection fuses				
	LV HRC design gG	Cylindrical design gG		DIAZED quick	
	3NA6	10 mm x 38 mm 3NW6 0	14 mm x 51 mm 3NW6 1	22 mm x 58 mm 3NW6 2	5SB

Operational voltage U_e up to 460 V (+10 %)					
3RF24 10-AB..	3NA3 801 ³⁾	3NW6 001-1 ³⁾	3NW6 101-1 ³⁾	--	5SB1 31 ³⁾
3RF24 10-AC..	3NA3 803	3NW6 001-1 ³⁾	3NW6 101-1 ³⁾	--	5SB1 61
3RF24 20-A...	3NA3 805 ³⁾	3NW6 005-1 ³⁾	3NW6 105-1 ³⁾	3NW6 205-1 ³⁾	5SB1 81
3RF24 30-A...	3NA3 812	--	3NW6 112-1	--	5SB3 11
3RF24 40-A...	3NA3 812 ³⁾	--	3NW6 112-1 ³⁾	3NW6 210-1 ³⁾	5SB3 21
3RF24 50-A...	3NA3 812 ³⁾	--	--	3NW6 210-1 ³⁾	5SB3 21 ³⁾

Suitable fuse holders, fuse bases and controls can be found in Catalog LV 1, Chapter 19.

- 1) Type of coordination "2" according to EN 60947-4-1:
In the event of a short-circuit, the controls in the load feeder must not endanger persons or the installation. They must be suitable for further operation. For fused configurations, the protective device must be replaced.
- 2) For use only with operational voltage U_e up to 400 V.
- 3) These fuses have a smaller rated current than the solid-state contactors.

Solid-State Switching Devices for Resistive Loads

Solid-State Contactors

3RF24 solid-state contactors, three-phase

Characteristic curves

Derating curves, two-phase controlled

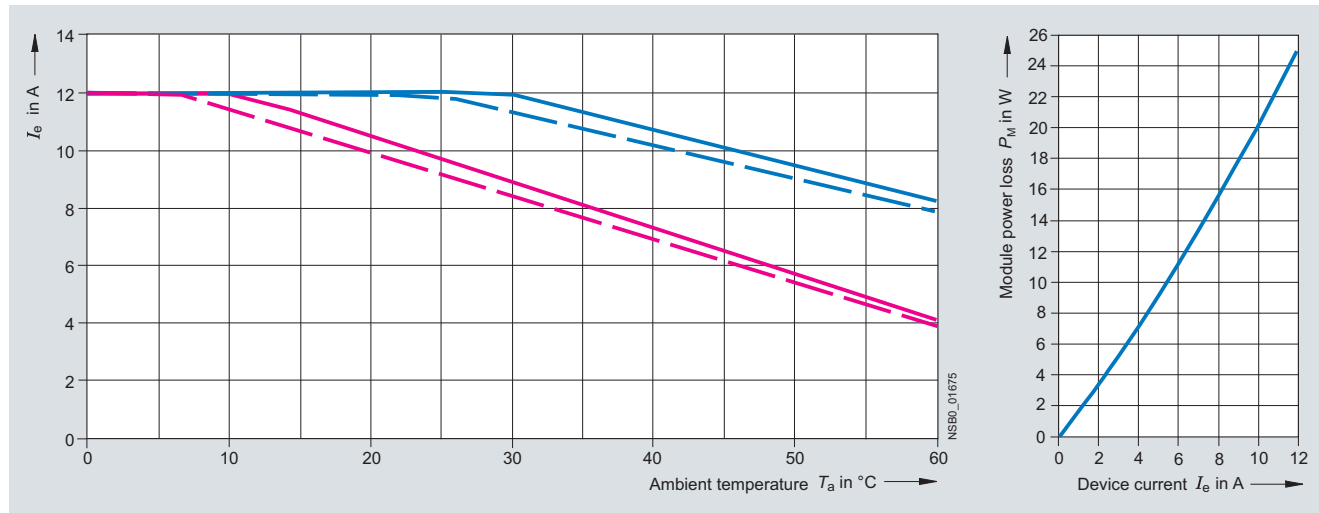

Type current 10.5 A (3RF24 10-AB..)

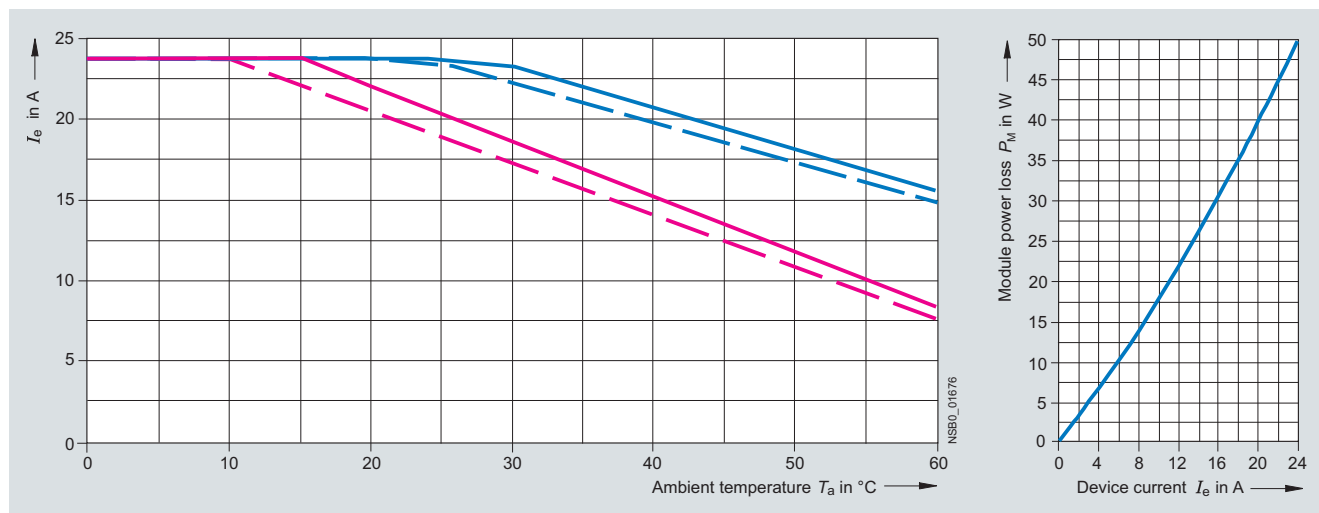

Type current 20 A (3RF24 20-AB..)

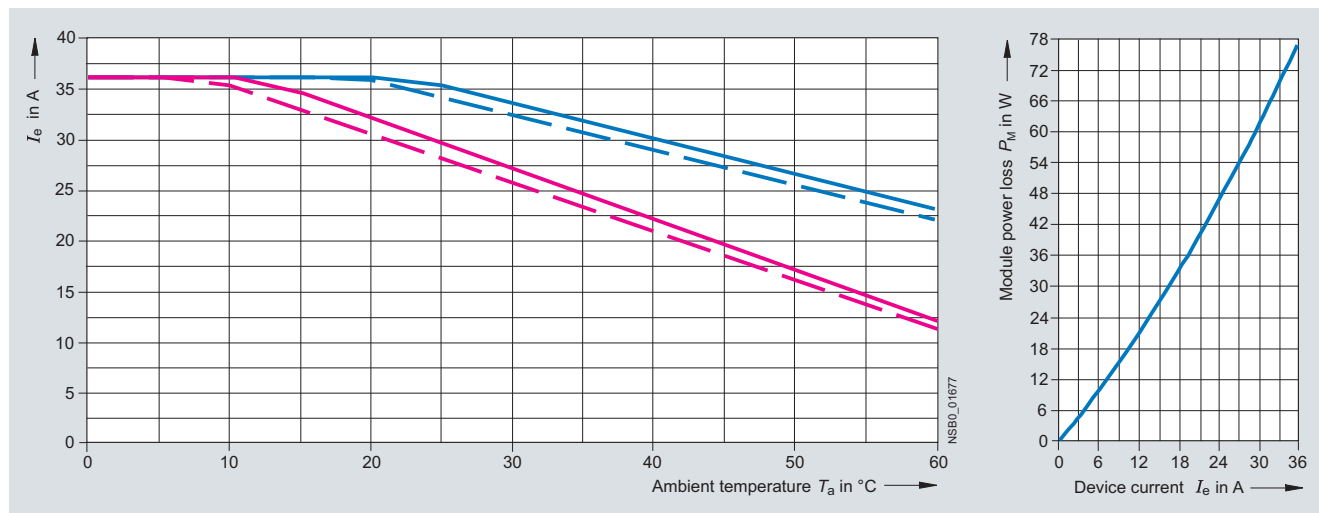

Type current 30 A (3RF24 30-AB..)

4

Solid-State Switching Devices for Resistive Loads

Solid-State Contactors

3RF24 solid-state contactors, three-phase

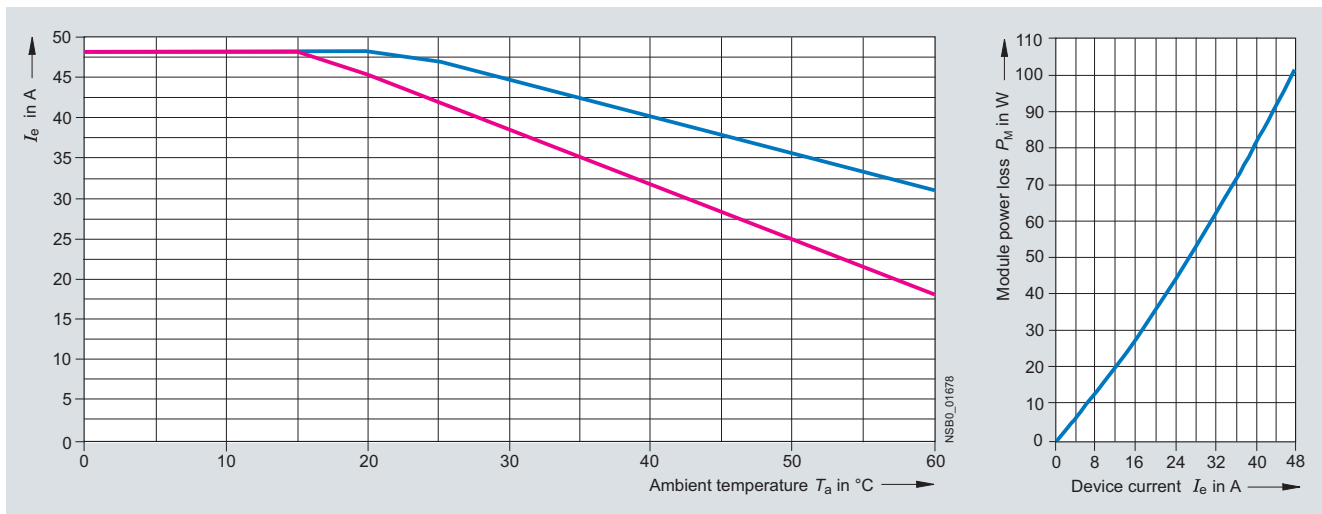

Type current 40 A (3RF24 40-AB..)¹)

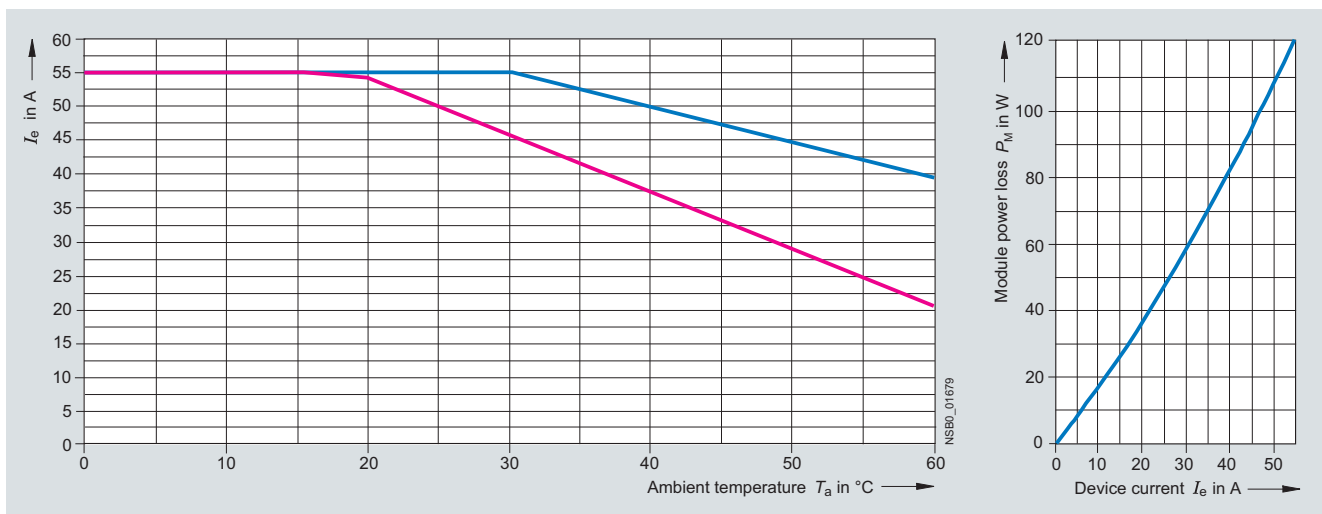

Type current 50 A (3RF24 50-AB..)¹)

- I_{max} Thermal limit current for individual mounting
- I_{max} Thermal limit current for side-by-side mounting
- I_{IEC} Current acc. to IEC 947-4-3 for individual mounting
- I_{IEC} Current acc. to IEC 947-4-3 for side-by-side mounting

Note: When loaded with IIEC, the maximum overtemperature at the heat sink is 50 K.

Mounting regulations

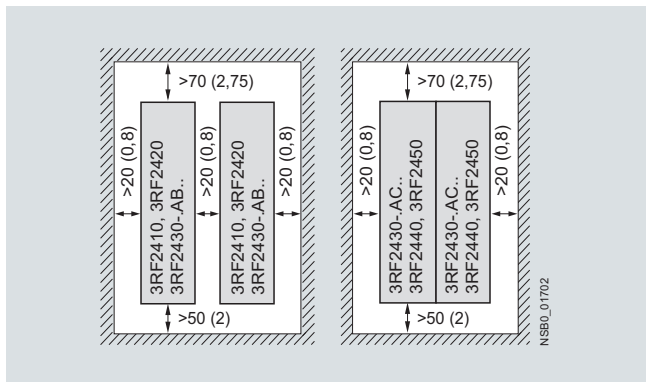

Clearances for stand-alone and side-by-side installation

¹) Identical current/temperature curves for stand-alone and side-by-side installation.

Solid-State Switching Devices for Resistive Loads

Solid-State Contactors

3RF24 solid-state contactors, three-phase

Derating curves, three-phase controlled

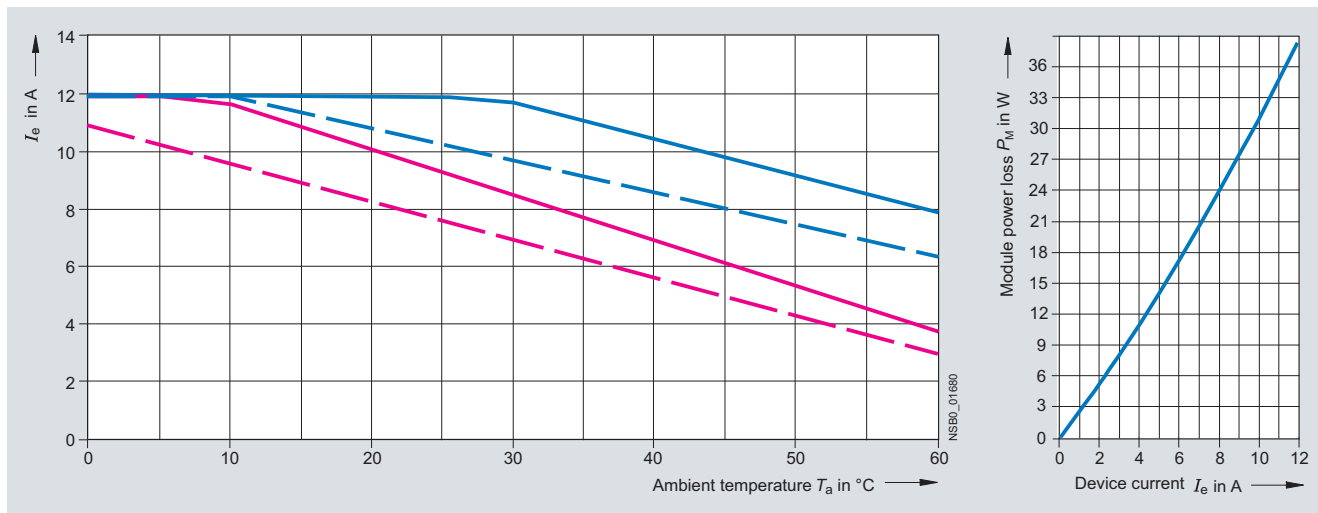

Type current 10.5 A (3RF24 10-.AC..)

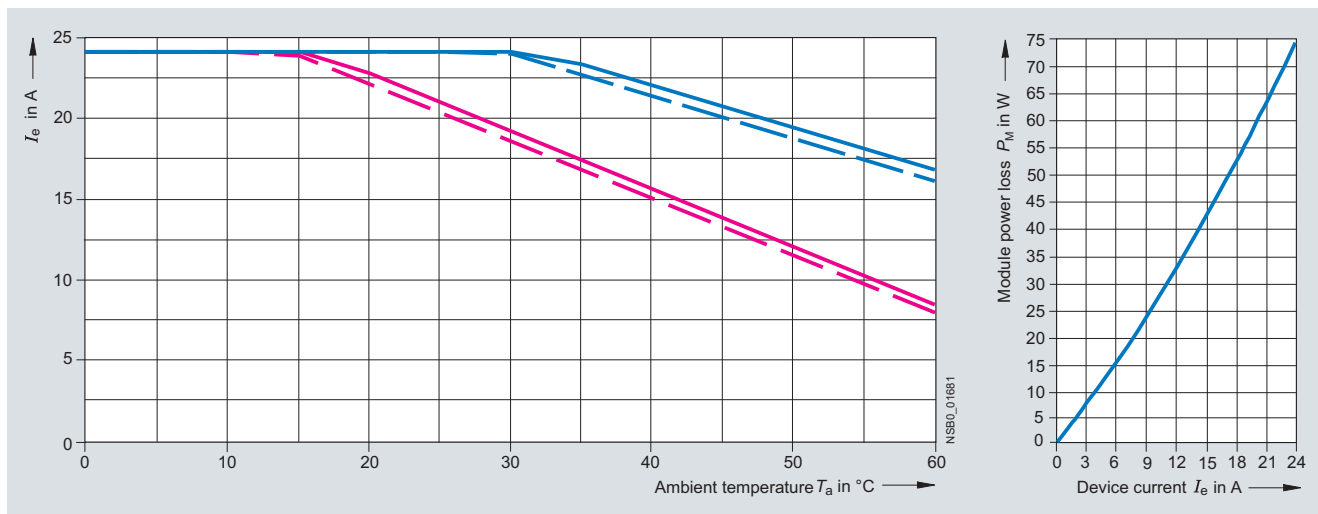

Type current 20 A (3RF24 20-.AC..)

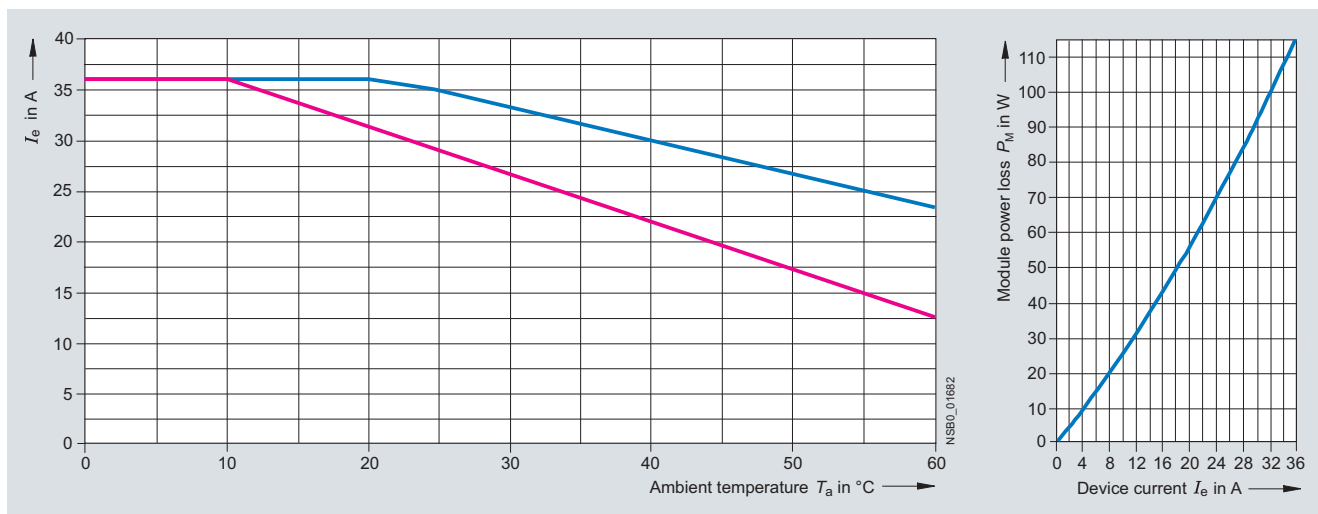

Type current 30 A (3RF24 30-.AC..) ¹⁾

¹⁾ Identical current/temperature curves for stand-alone and side-by-side installation.

4

Solid-State Switching Devices for Resistive Loads

Solid-State Contactors

3RF24 solid-state contactors, three-phase

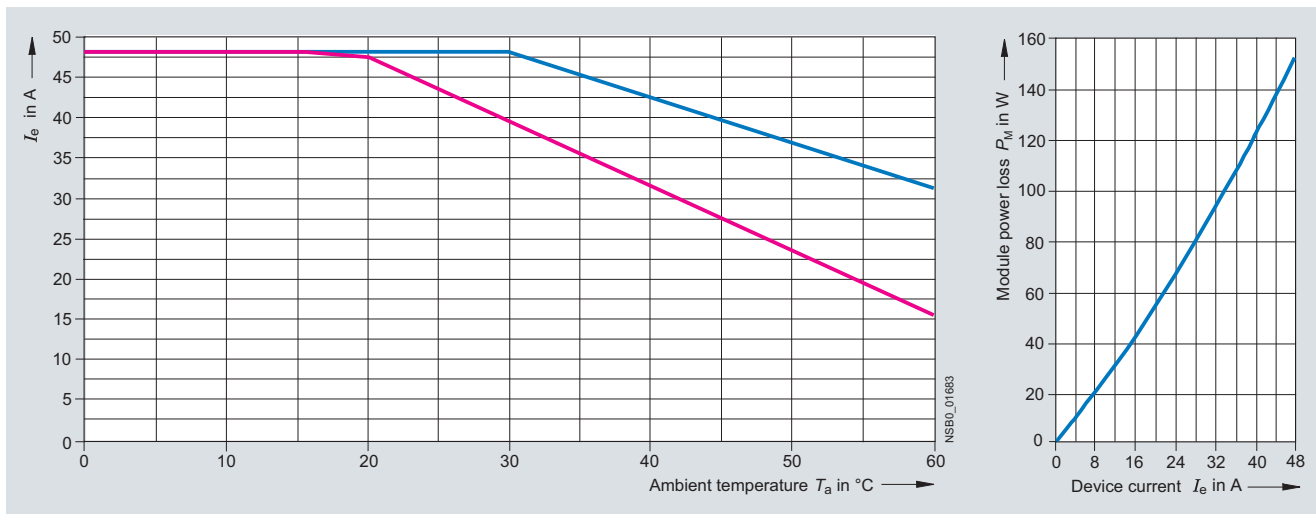

Type current 40 A (3RF24 40-.AC..)¹)

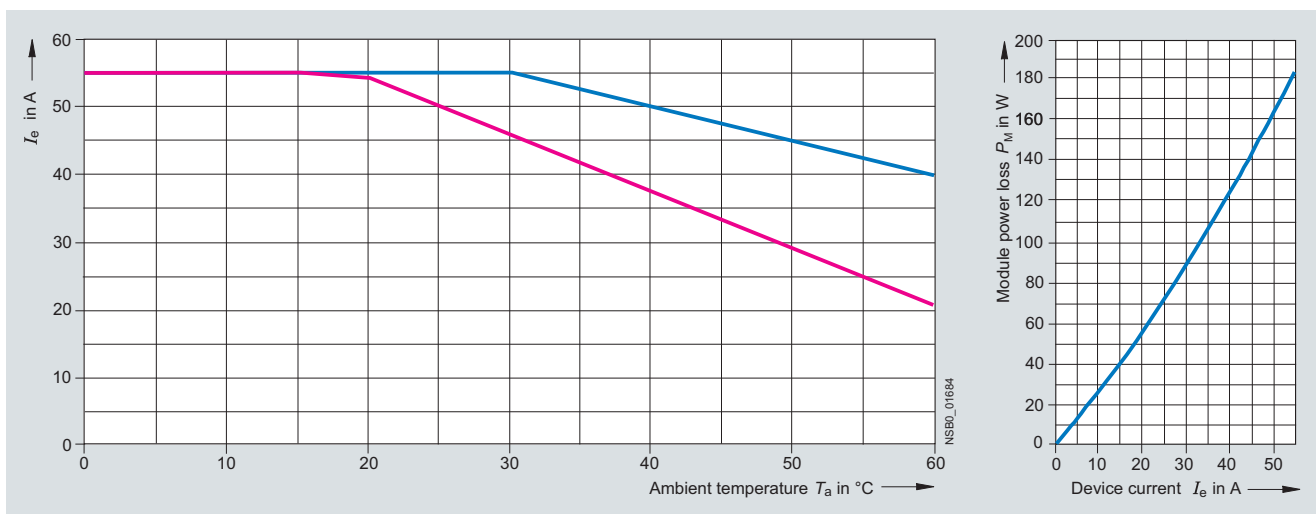

Type current 50 A (3RF24 50-.AC..)¹)

- I_{max} Thermal limit current for individual mounting
- I_{max} Thermal limit current for side-by-side mounting
- I_{IEC} Current acc. to IEC 947-4-3 for individual mounting
- I_{IEC} Current acc. to IEC 947-4-3 for side-by-side mounting

Note: When loaded with IIEC, the maximum overtemperature at the heat sink is 50 K.

Mounting regulations

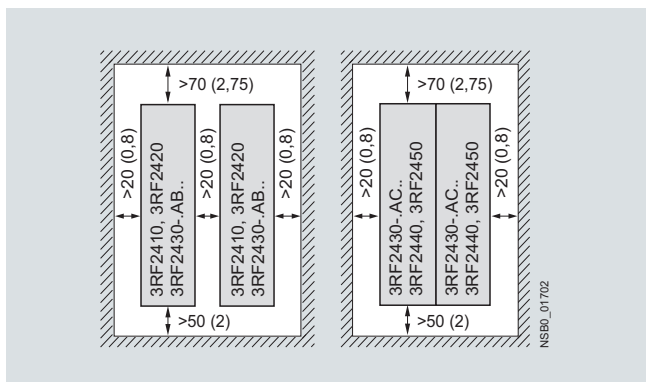

Clearances for stand-alone and side-by-side installation

¹) Identical current/temperature curves for stand-alone and side-by-side installation.

Solid-State Switching Devices for Resistive Loads

Solid-State Contactors

3RF24 solid-state contactors, three-phase

Dimensional drawings

Type current 10.5 A

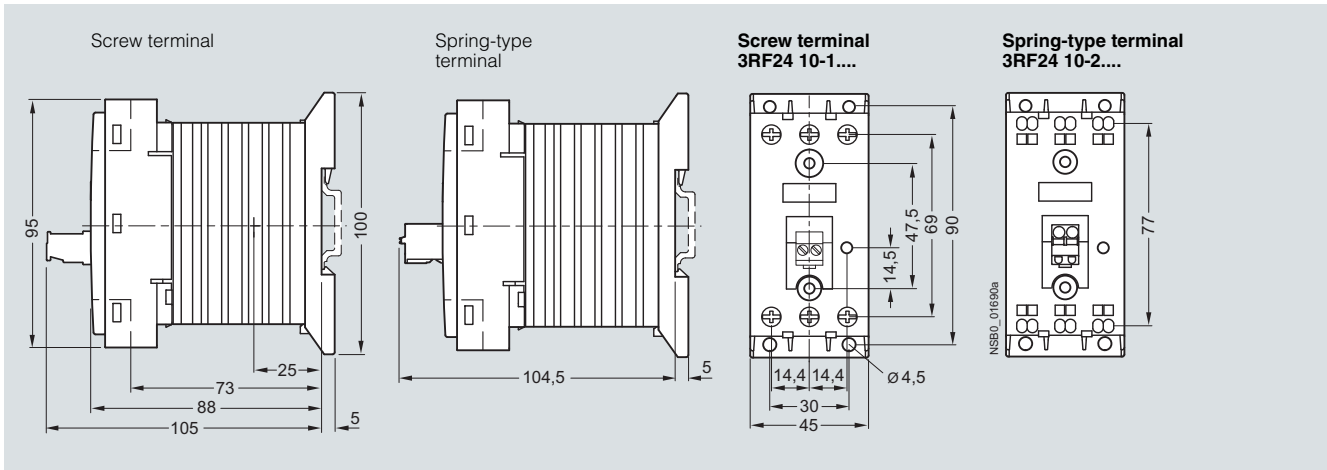

Type current 20 A; 30 A (two-phase controlled)

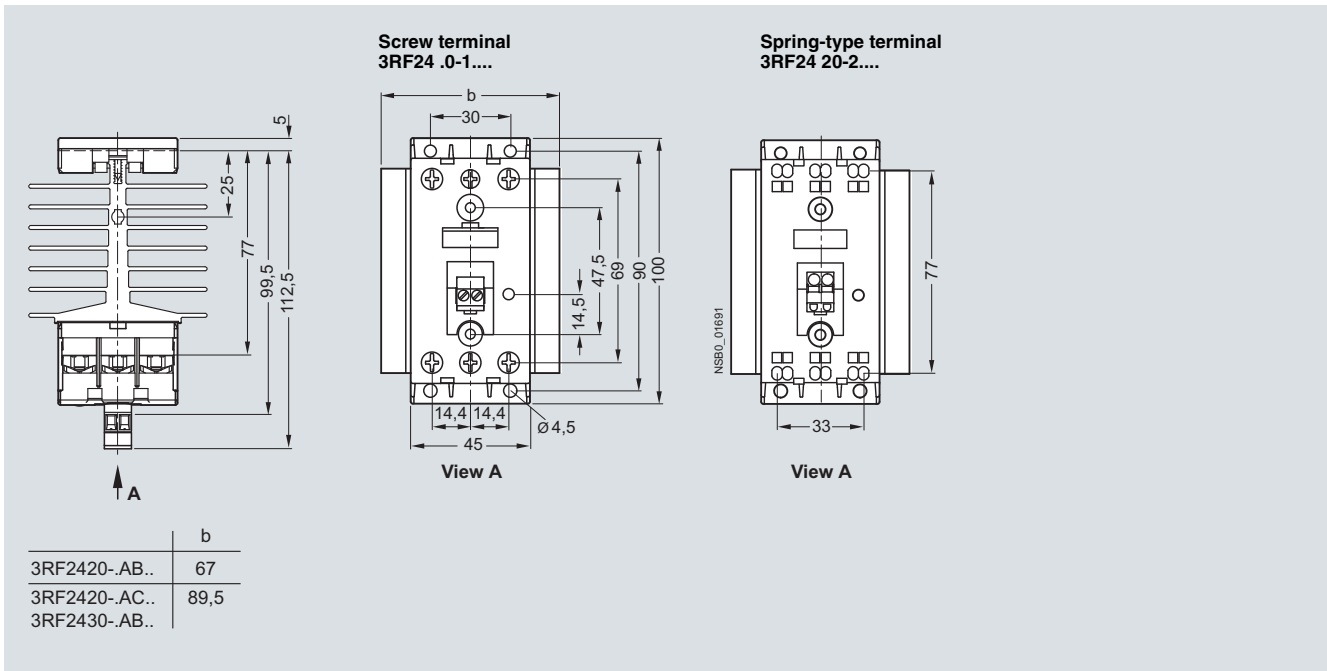

4

Solid-State Switching Devices for Resistive Loads

Solid-State Contactors

3RF24 solid-state contactors, three-phase

Type current 30 A (three-phase controlled); 40 A, 50 A

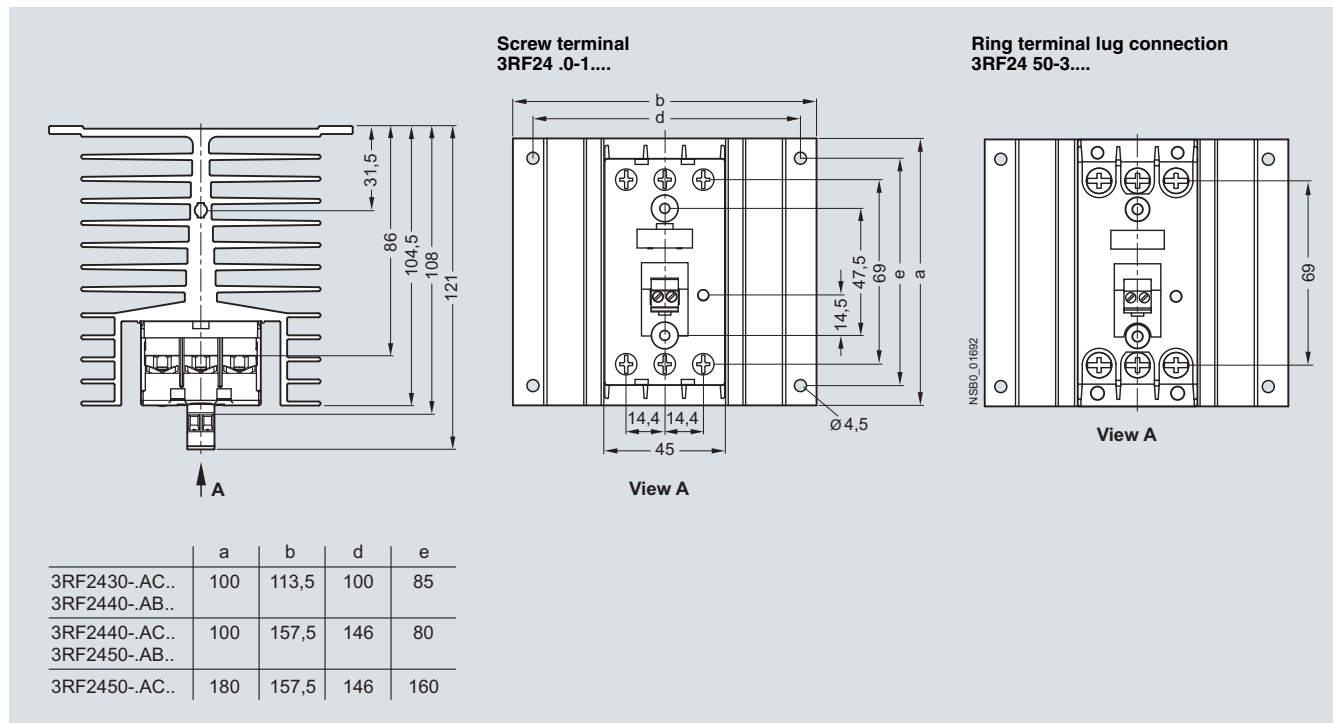

Schematics

Two-phase controlled, DC control supply voltage

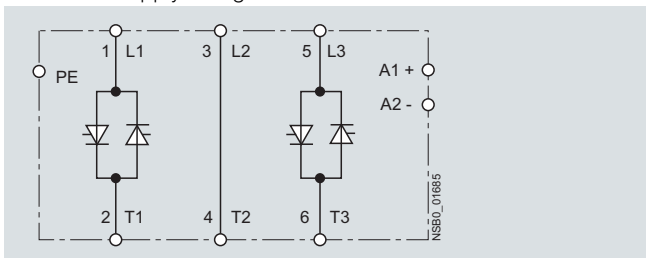

Three-phase controlled, DC control supply voltage

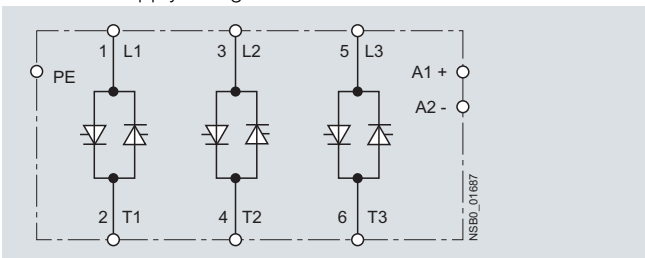

Two-phase controlled, AC control supply voltage

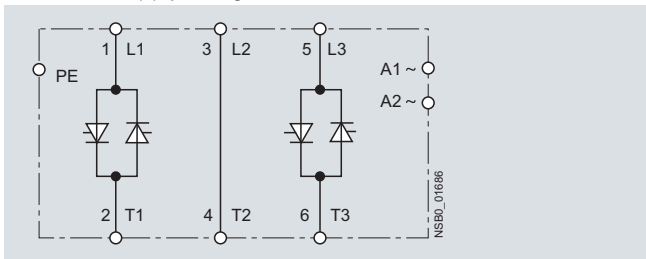

Three-phase controlled, AC control supply voltage

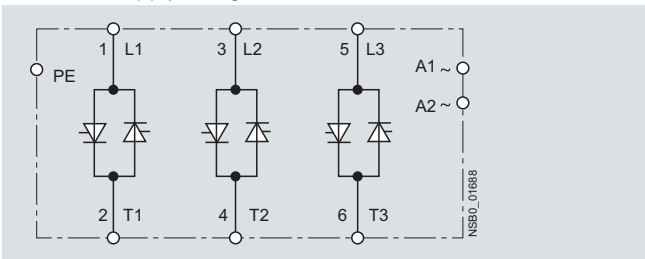

Solid-State Switching Devices for Resistive Loads

3RF29 Function Modules

General data

Overview

Function modules for SIRIUS 3RF2 solid-state switching devices

A great variety of applications demand an expanded range of functionality. With our function modules, these requirements can be met really easily. The modules are mounted simply by clicking them into place; straight away the necessary connections are made with the solid-state relay or contactor. The plug-in connection to control the solid-state switching devices can simply remain in use.

The following function modules are available:

- Converters
- Load monitoring
- Heating current monitoring
- Power controllers
- Power regulators

With the exception of the converter, the function modules can be used only with single-phase solid-state switching devices.

Technical specifications

Type	3RF29 ..-E...	3RF29 ..-F...	3RF29 ..-G...	3RF29 ..-H...	3RF29 ..-J...	3RF29 ..-K...
General data						
Ambient temperature						
• During operation, derating from 40 °C	°C	-25 ... +60				
• During storage	°C	-55 ... +80				
Installation altitude	m	0 ... 1000; derating from 1000				
Shock resistance acc. to IEC 60068-2-27	g/ms	15/11				
Vibration resistance acc. to IEC 60068-2-6	g	2				
Degree of protection		IP20				
Electromagnetic compatibility (EMC)						
• Emitted interference						
- Conducted interference voltage acc. to IEC 60947-4-3		Class A for industrial applications ¹⁾				
- Emitted, high-frequency interference voltage acc. to IEC 60947-4-3		Class A for industrial applications				
• Interference immunity						
- Electrostatic discharge acc. to IEC 61000-4-2 (corresponds to degree of severity 3)	kV	Contact discharge 4; air discharge 8; behavior criterion 2				
- Induced RF fields acc. to IEC 61000-4-6	MHz	0.15 ... 80; 140 dB μ V; behavior criterion 1				
- Burst acc. to IEC 61000-4-4		2 kV/5.0 kHz; behavior criterion 1				
- Surge acc. to IEC 61000-4-5	kV	Conductor - ground 2; conductor - conductor 1; behavior criterion 2				
Connection, auxiliary/control contacts, screw terminals						
• Conductor cross-section	mm ²	1 x (0.5 ... 2.5), 2 x (0.5 ... 1.0), 1 x (AWG 20 ... 12)				
• Stripped length	mm	7				
• Terminal screw		M3				
• Tightening torque	Nm lb.in	0.5 ... 0.6 4.5 ... 5.3				
Converter, feed-through opening						
• Diameter	mm	--	7	17		

¹⁾ Note limitations for power controller function modules. These modules were built as Class A devices. The use of these devices in residential areas could result in lead in radio interference. In this case these may be required to introduce additional interference suppression measures.

Solid-State Switching Devices for Resistive Loads

3RF29 Function Modules

General data

Type		3RF29 ...E..8	3RF29 ...F..8	3RF29 ...G..3	3RF29 ...G..6
Main circuit					
Rated operational voltage U_e	V	-- 1)		110 ... 230	400 ... 600
• Operating range	V	--		93.5 ... 253	340 ... 660
• Rated frequency	Hz	--		50/60	
Rated insulation voltage U_i	V	--		600	
Voltage measuring					
• Measuring range	V	--		93.5 ... 253	340 ... 660
Mains voltage, fluctuation compensation					
	%	--		20	

1) Versions are independent of the main circuit.

Type		3RF29 ...H..3 3RF29 ...K..3	3RF29 ...H..6 3RF29 ...K..6	3RF29 ...J..3	3RF29 ...J..6
Main circuit					
Rated operational voltage U_e	V	110 ... 230	400 ... 600	110 ... 230	400 ... 600
• Operating range	V	93.5 ... 253	340 ... 660	93.5 ... 253	340 ... 660
• Rated frequency	Hz	50/60			
Rated insulation voltage U_i	V	600			
Voltage measuring					
• Measuring range	V	93.5 ... 253	340 ... 660	93.5 ... 253	340 ... 660
Mains voltage, fluctuation compensation					
	%	20			

Type		3RF29 ...0.	3RF29 ...1.	3RF29 ...3.
Control circuit				
Method of operation		DC operation	AC/DC operation	AC operation
Rated control supply voltage U_s	V	24	24	110
Rated control current	mA	15	15	15
Rated frequency of the control supply voltage	Hz	--	50/60	50/60
Actuating voltage, max.	V	30	30	121
Rated control current At maximum voltage	mA	15	15	15
Response voltage	V	15	15	90
• For operating current	mA	2	2	2
Drop-out voltage	V	5	5	15

Type		3RF29 06-0FA08	3RF29 20-0FA08	3RF29 20-0GA..	3RF29 50-0GA..	3RF29 90-0GA..
Current measurement						
Rated operational current I_e	A	6	20	20	50	90
Current measurement						
• Teach range	A	0.25 ... 6	0.65 ... 20	0.56 ... 20	1.62 ... 50	2.93 ... 90
• Measuring range	A	0 ... 6.6	0 ... 22	0 ... 22	0 ... 55	0 ... 99
• Minimum partial load current	A	0.25	0.65	0.65	1.6	2.9
Number of partial loads		1 ... 6	1 ... 6	1 ... 12		

Type		3RF29 20-0HA..	3RF29 50-0HA..	3RF29 90-0HA..	3RF29 16-0JA..	3RF29 32-0JA..
Current measurement						
Rated operational current I_e	A	20	50	90	16	32
Current measurement						
• Teach range	A	4 ... 20	10 ... 50	18 ... 90	0.42 ... 16	0.8 ... 32
• Measuring range	A	0 ... 22	0 ... 55	4 ... 99	0 ... 16	0 ... 32
• Minimum partial load current	A	--	--	--	0.42	0.8
Number of partial loads		--	--	--	1 ... 6	--

Type		3RF29 04-0KA..	3RF29 20-0KA..	3RF29 50-0KA..	3RF29 90-0KA..
Current measurement					
Rated operational current I_e	A	4	20	50	90
Current measurement					
• Teach range	A	0.15 ... 4	0.65 ... 20	1.6 ... 50	2.9 ... 90
• Measuring range	A	0 ... 4	0 ... 22	0 ... 55	0 ... 99
• Minimum partial load current	A	--	0.65	1.6	2.9
Number of partial loads		--	1 ... 6	--	--

Solid-State Switching Devices for Resistive Loads

3RF29 Function Modules

Converters

Overview

Converters for 3RF2 solid-state switching devices

These modules are used to convert analog control signals, such as those output from many temperature controllers for example, into a pulse-width-modulated digital signal. The connected solid-state contactors and relays can therefore regulate the output of a load as a percentage.

Design

Mounting

Easy snapping onto the 3RF21/3RF22 solid-state relays or 3RF23/3RF24 solid-state contactors establishes the connections to the solid-state switching devices. The connector on the solid-state switching devices from the control circuit can be plugged onto the converter without rewiring.

Function

The analog value from a temperature controller is present at the 0 ... 10 V terminals. This controls the on-to-off period, as a function of voltage. The period duration is predefined at one second. Conversion of the analog voltage is linear in the voltage range from 0.1 ... 9.9 V. At voltages below approx. 0.1 V the connected switching device is not activated, while at voltages above approx. 9.9 V the connected switching device is always activated.

Solid-State Switching Devices for Resistive Loads

3RF29 Function Modules

Load monitoring

Overview

Load monitoring for 3RF2 single-phase solid-state switching devices

Many faults can be quickly detected by monitoring a load circuit connected to the solid-state switching device, as made possible with this module. Examples include the failure of load elements (up to 6 in the basic version or up to 12 in the extended version), alloyed power semiconductors, a lack of voltage or a break in a load circuit. A fault is indicated by one or more LEDs and reported to the controller by way of a PLC-compatible output.

The principle of operation is based on permanent monitoring of the current strength. This figure is continuously compared with the reference value stored once during commissioning by the simple press of a button. In order to detect the failure of one of several loads, the current difference must be 1/6 (in the basic version) or 1/12 (in the extended version) of the reference value. In the event of a fault, an output is actuated and one or more LEDs indicate the fault.

Design

Mounting

Easy snapping onto the 3RF21 solid-state relays or 3RF23 solid-state contactors establishes the connections to the solid-state switching devices. Because of the special design, the straight-through transformer of the load monitoring module covers the lower main circuit connection. The cable to the load is simply pushed through and secured with the terminal screw.

Function

The function module is activated when an "ON" signal is applied (IN terminal). The module constantly monitors the current level and compares this with the setpoint value.

Startup

Pressing the Teach button or actuating the input IN2 switches the device on; the current through the solid-state switching device is detected and is stored as the setpoint value. During this process the two lower (red¹⁾) LEDs flash alternately; simultaneous continuous light from the 3 (red¹⁾) LEDs indicates the conclusion of the teaching process.

The Teach button can also be used to switch on the connected solid-state switching device briefly for test purposes. In this case the "ON" LED is switched on.

Partial load faults, "Basic" load monitoring

If a deviation of at least 1/6 of the stored setpoint value is detected, a fault is signaled. The fault is indicated by a "Fault" LED and by activation of the fault signaling output.

LEDs	OK	Fault		
		Partial load failure/ load short-circuit	Thyristor defect	Mains failure/ Fuse rupture
ON/OFF	✓	✓	--	✓
Current flowing	✓	✓	✓	--
Group fault	--	✓	✓	✓

✓ LED is lit

-- LED is not lit

Partial load faults, "Extended" load monitoring

Depending on the setting of the "response time" potentiometer, a deviation of at least 1/12 of the stored setpoint value after a response time of between 100 ms and 3 s is signaled as a fault. The fault is indicated by a "Load" LED and by activation of the fault signaling output.

The potentiometer can also be used to determine the response behavior of the fault signaling output. When delay values are set in the left-hand half, the fault signal is stored. This can only be reset by switching on and off by means of the control supply voltage.

When settings are made on the right-hand side, the fault output is automatically reset after the deviation has been corrected.

Voltage compensation, "Extended" load monitoring

In addition to the current, the load voltage is also detected. This makes it possible to compensate for influences on the current strength resulting from voltage fluctuations.

Thyristor fault

If a current greater than the leakage current of the controls is measured in the deenergized state, the device triggers a thyristor fault after the set delay time. This means that the fault output is activated and the "Fault" ("Thyristor"¹⁾) LED lights up.

Power system fault

If no current is measured in the energized state, the device triggers a power system fault after the set delay time. This means that the fault output is activated and the "Fault" ("Supply"¹⁾) LED lights up.

¹⁾ Only "Extended" load monitoring.

Solid-State Switching Devices for Resistive Loads

3RF29 Function Modules

Heating current monitoring

Overview

Heating current monitoring for 3RF2 single-phase solid-state switching devices

Many faults can be quickly detected by monitoring a load circuit connected to the solid-state switching device, as made possible with this module. Examples include the failure of up to 6 load elements, alloyed power semiconductors, a lack of voltage or a break in a load circuit. A fault is indicated by LEDs and reported to the controller by way of a relay output (NC contact).

The principle of operation is based on permanent monitoring of the current strength. This figure is continuously compared with the reference value stored once during commissioning. In order to detect the failure of one of several loads, the current difference must be 1/6 of the reference value. In the event of a fault, an output is actuated and the LEDs indicate the fault.

The heating current monitoring has a teach input and therefore differs from the load monitoring. This remote teaching function enables simple adjustment to changing loads without manual intervention.

Design

Mounting

Easy snapping onto the 3RF21 solid-state relays or 3RF23 solid-state contactors establishes the connections to the solid-state switching devices. Because of the special design, the straight-through transformer of the heating current monitoring module covers the lower main circuit connection. The cable to the load is simply pushed through and secured with the terminal screw.

Function

The function module is activated when an "ON" signal is applied (IN1 terminal). The module constantly monitors the current level and compares this with the setpoint value.

Startup

Actuating the input IN2 switches the device on; the current through the solid-state switching device is detected and is stored as the setpoint value. During this process the two lower (red) LEDs flash alternately; simultaneous continuous light from the 3 (red) LEDs indicates the conclusion of the teaching process.

Partial load faults

Depending on the setting of the "response time" potentiometer, a deviation of at least 1/6 of the stored setpoint value after a response time of between 100 ms and 3 s is signaled as a fault. The fault is indicated by a "Load" LED and by activation of the fault signaling output.

The potentiometer can also be used to determine the response behavior of the fault signaling output. When delay values are set in the left-hand half, the fault signal is stored. This can only be reset by switching on and off by means of the control supply voltage.

When settings are made on the right-hand side, the fault output is automatically reset after the deviation has been corrected.

Voltage compensation

In addition to the current, the load voltage is also detected. This makes it possible to compensate for influences on the current strength resulting from voltage fluctuations.

Thyristor fault

If a current greater than the leakage current of the controls is measured in the deenergized state, the device triggers a thyristor fault after the set delay time. The fault output is activated and the "Thyristor" LED lights up.

Power system fault

If no current is measured in the energized state, the device triggers a power system fault after the set delay time. The fault output is activated and the "Supply" LED lights up.

Solid-State Switching Devices for Resistive Loads

3RF29 Function Modules

Power controllers

Overview

Power controllers for 3RF2 single-phase solid-state switching devices

The power controller is a function module for the autonomous power control of complex heating systems and inductive loads, for the operation of loads with temperature-dependent resistors and for simple indirect control of temperature.

The power controller can be used on the instantaneously switching 3RF21 and 3RF23 solid-state switching devices (single-phase). If only the full-wave operating mode is used, the power controller can also be used on the "zero-point switching" solid-state relays and contactors.

The following functions have been integrated:

- **Power controller** for adjusting the power of the connected load. Here, the setpoint value is set with a rotary knob on the module as a percentage with reference to the 100 % power stored as a setpoint value.
- **Inrush current limitation:** With the aid of an adjustable voltage ramp, the inrush current is limited by means of phase control. This is useful above all with loads such as lamps or infrared lamps which have an inrush transient current.
- **Load circuit monitoring** for detecting load failure, partial load faults, alloyed power semiconductors, lack of voltage or a break in the load circuit.

Special versions

3RF29 04-0KA13-0KC0

During the Teaching process the connected solid-state relay or contactor is not activated; i. e. no current flow takes place. No current reference value is stored. No part-load monitoring!

3RF29 ..-0KA1.-0KT0

No part-load monitoring!

Design

Mounting

Easy snapping onto the 3RF21 solid-state relays or 3RF23 solid-state contactors establishes the connections to the solid-state switching devices. Because of the special design, the straight-through transformer of the function module covers the lower main circuit connection. The cable to the load is simply pushed through and secured with the terminal screw.

Function

Power control

The power controller sets the load current of the solid-state switching device depending on a setpoint value as a percentage. It does not compensate for changes in the mains voltage or load resistance. The modulation, the On/Off ratio or the phase angle, remains unchanged according to the setpoint value. The autonomous power control is performed between 0 and 100 % of the setpoint selection.

Full-wave control

If the left potentiometer t_R is set to 0 s (= far left), then the power controller operates according to the principle of full-wave control. The power set, be it internal or external, is converted into a pulse-width-modulated digital signal. The power controller controls the On and Off time of the solid-state switching device within a fixed period duration of 1 s so that the selected power is applied to the load. The "ON" LED flashes in the same rhythm as the solid-state switching device switches on and off.

Generalized phase control

If the left potentiometer t_R is set to greater than 0 s, then the power controller operates according to the principle of generalized phase control.

In order to observe the limit values of the conducted interference voltage for industrial networks, the load circuit must include a reactor with a rating of at least 200 μ H.

For SIDAC reactors for generalized phase control mode see page 4/48.

Setpoint selection

The setpoint selection is set either internally with the right-hand potentiometer P to 0 ... 100 % on the module or externally using the analog input 0 ... 10 V.

In the case of full-wave control, 100 % corresponds to continuously On and, in the case of generalized phase control, to a conduction angle of 180° – and therefore maximum output.

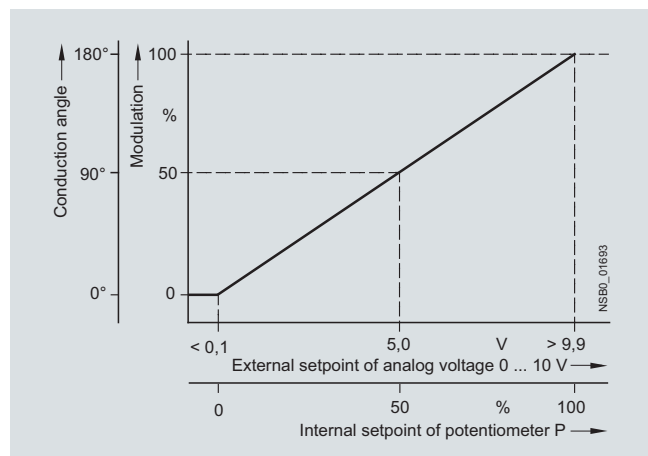

Input characteristic

Internal setpoint selection

In the case of internal setpoint selection, the module is controlled over the IN terminal. Terminal 10 has no function.

External setpoint selection

With external setpoint selection (potentiometer P far left = 0 %) the module is actuated by applying the analog voltage 0 ... 10 V. 0 ... 10 V corresponds to 0 ... 100 % power. Conversion of the voltage is linear between 0.1 and 9.9 V. Below 0.1 V the switching device remains off; at voltages above 9.9 V the power is always set to 100 %.

Inrush current limitation

The ramp time (t_R) for a voltage ramp on switching on is set with the left potentiometer for the purpose of inrush current limitation. The set time refers to a power of 100 %. If, for example, a ramp time of 10 s is set and the power setpoint selection is 60 %, then the power of 60 % will be reached after approx. 6 s.

Line, load and thyristor monitoring

The power controller identifies partial load faults, mains failure and thyristor faults. The faults are indicated by the LEDs on the module and the fault output is actuated. The reference for the load monitoring is the taught value. A maximum of 6 partial loads can be monitored.

The response delay in the event of a fault amounts to approx. 100 ms in the case of full-wave control. In the case of generalized phase control and setpoint values > 50 % the response delay amounts to 500 ms from the end of the ramp time.

The detection of partial load faults takes place only in the control range from 20 ... 100 %.

Solid-State Switching Devices for Resistive Loads

3RF29 Function Modules

Power regulators

Overview

Power regulators for 3RF2 single-phase solid-state switching devices

The power regulator is a function module for the autonomous power control of complex heating systems, for the operation of loads with temperature-dependent resistors and for simple indirect control of temperature.

The power regulator can be used on the instantaneously switching 3RF21 and 3RF23 solid-state switching devices (single-phase). If only the full-wave operating mode is used, the power regulator can also be used on the zero-point-switching solid-state relays and contactors.

The following functions have been integrated:

- **Power controller with proportional-action control** for adjusting the power of the connected load. Here, the setpoint value is set with a rotary knob on the module as a percentage with reference to the 100 % power stored as a setpoint value. Changes in the mains voltage or in the load resistance are compensated in this case.
- **Inrush current limitation:** With the aid of an adjustable voltage ramp, the inrush current is limited by means of phase control. This is useful above all with loads such as lamps which have an inrush transient current.
- **Load circuit monitoring** for detecting load failure, alloyed power semiconductors, lack of voltage or a break in the load circuit.

Design

Mounting

Easy snapping onto the 3RF21 solid-state relays or 3RF23 solid-state contactors establishes the connections to the solid-state switching devices. Because of the special design, the straight-through transformer of the function module covers the lower main circuit connection. The cable to the load is simply pushed through and secured with the terminal screw.

Function

Power control

The power regulator adjusts the current in the connected load by means of a solid-state switching device depending on a setpoint value. Changes in the mains voltage or in the load resistance are thus compensated by the power regulator. The setpoint value can be predefined externally as a 0 to 10 V signal or internally by means of a potentiometer. Depending on the setting of the potentiometer (t_p), the adjustment is carried out according to the principle of full-wave control or generalized phase control.

Full-wave control

In this operating mode the output is adjusted to the required setpoint value changing the on-to-off period. The period duration is predefined at one second.

Generalized phase control

In this operating mode the output is adjusted to the required setpoint value by changing the current flow angle. The half-waves of the current are adjusted to produce the selected setpoint value of the power at the load.

In order to observe the limit values of the conducted interference voltage for industrial networks, the load circuit must include a reactor with a rating of at least 200 μH .

SIDAC reactors for generalized phase control mode

Power control regulators, power regulators	Reactors		
	Rated voltage		
Type	Up to 230 V	Up to 480 V	Up to 660 V
3RF2904-0KA.	4EM4700-8CB00	4EM4915-0CB00	4EM5007-7CB00
3RF2920-0KA./-0HA.	4EM4700-8CB00	4EM4915-0CB00	4EM5007-7CB00
3RF2950-0KA./-0HA.	4EM5001-1CB00	4EM6100-6CB00	4EM6204-0CB00
3RF2990-0KA./-0HA.	4EM6100-5CB00	4EM5316-7CB00	4EM5412-0CB00

Setpoint selection

The setpoint selection is set either internally with the right-hand potentiometer P to 0 ... 100 % on the module or externally using the analog input 0 ... 10 V.

External setpoint selection

At 0 % on the potentiometer the setpoint selection is set using an external 0 ... 10 V analog signal (terminals IN / 0 ... 10 V). The device is switched on and off via the power supply (terminals A1/A2).

Internal setpoint selection

Above 0 % the setpoint is set using the potentiometer. To allow this, the potential at terminal A1 must additionally be applied at the IN terminal. After removal of the "ON" signal, the switching module is switched off.

Inrush current limitation

The ramp time (t_p) for a voltage ramp on switching on is set with the left potentiometer for the purpose of inrush current limitation. If a time longer than 0 s is set, the device operates according to the generalized phase control principle. If 0 s is set, there is no voltage ramp and the device operates according to the principle of full-wave control.

Load fault

If upon switching on with voltage applied the current flowing is not greater than the leakage current of the control, the device triggers a load fault. The fault relay is activated and the "Load" LED lights up.

Thyristor fault

If a current greater than the leakage current of the control is measured in the deenergized state, the device triggers a thyristor fault. The fault relay is activated and the "Thyristor" LED lights up.

Power system fault

If no current is measured in the energized state, the device triggers a power system fault. The fault relay is activated and the "Supply" LED lights up.

Startup

Pressing the "Teach" button switches the device on; the current through the solid-state switching device and the mains voltage are detected and stored. The resultant output is taken as the 100 % output for the setpoint selection. During this process the two lower red LEDs flash alternately. Simultaneous continuous light from the three red LEDs indicates the completion of the "Teach" process.

The "Teach" button can also be used to switch on the connected solid-state switching device briefly for test purposes. In this case the "ON" LED is switched on.

Solid-State Switching Devices for Resistive Loads

3RF29 Function Modules

Project planning aids

Dimensional drawings

Converters

3RF29 00-0EA18

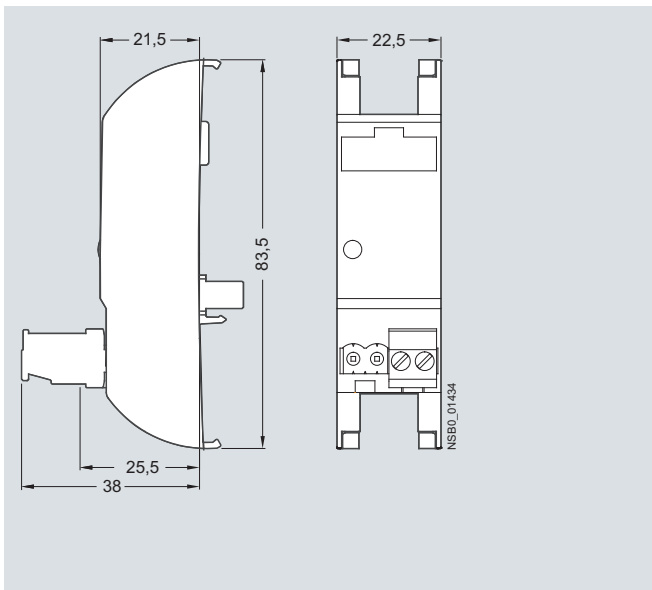

Basic load monitoring

3RF29 ..-0FA08

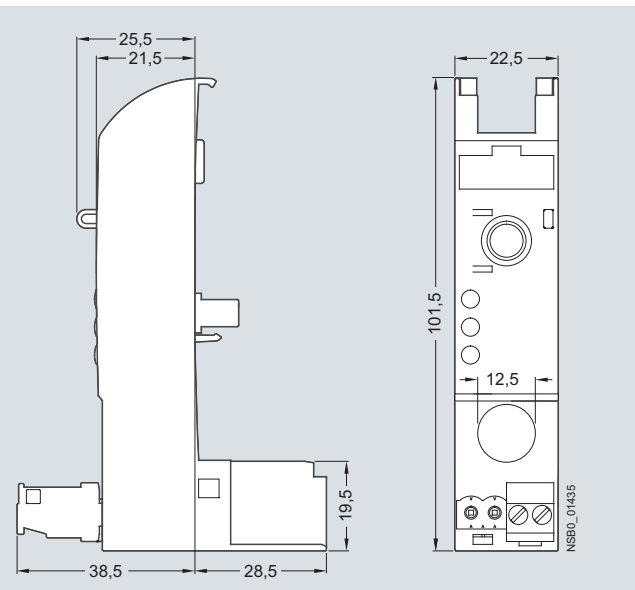

"Extended" load monitoring and heating current monitoring

3RF29 ..-0GA.. and -0JA..

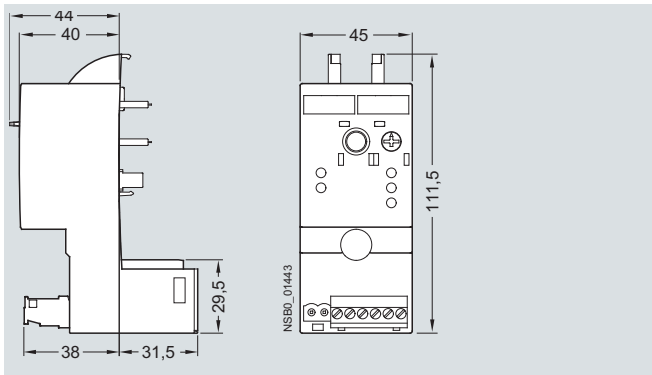

Power controllers and regulators

3RF29 ..-0KA..., 3RF29 ..-0HA..

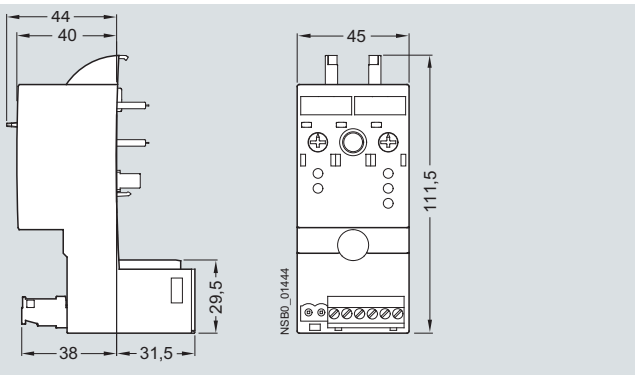

Schematics

Converter

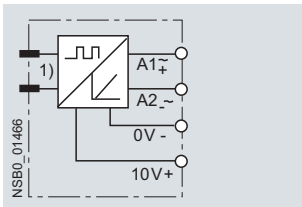

Basic load monitoring

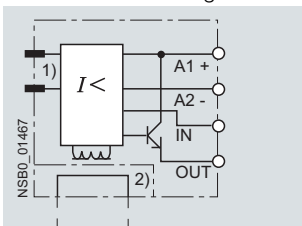

Extended load monitoring

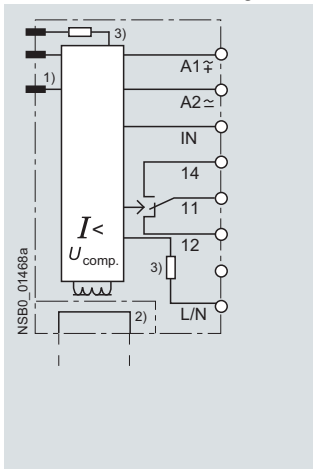

Heating current monitoring

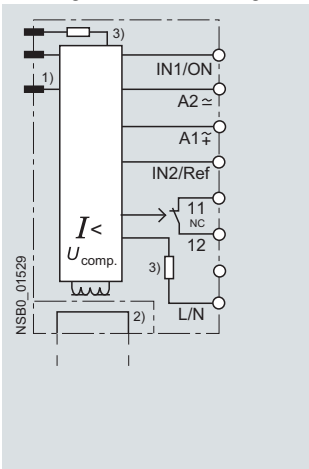

Power controller and regulator

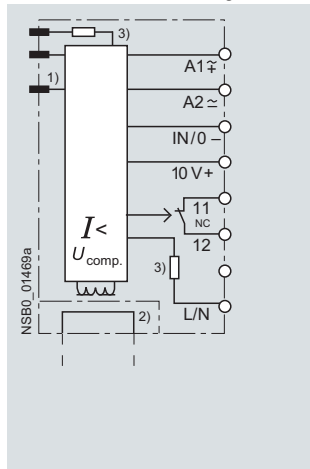

- 1) Internal connection.
- 2) Straight-through transformers.

- 3) Voltage measuring not electrically isolated (3 MΩ per path).

Solid-State Switching Devices for Resistive Loads

3RF29 Function Modules

Project planning aids

Switching examples

Converter

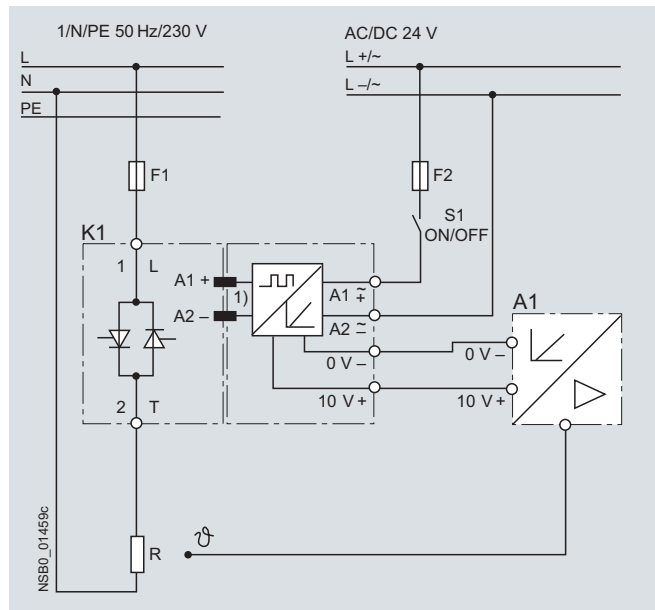

Basic load monitoring

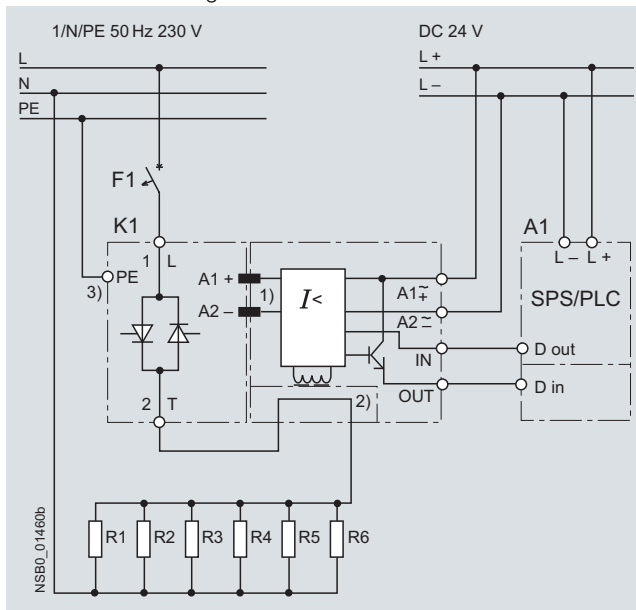

Extended load monitoring

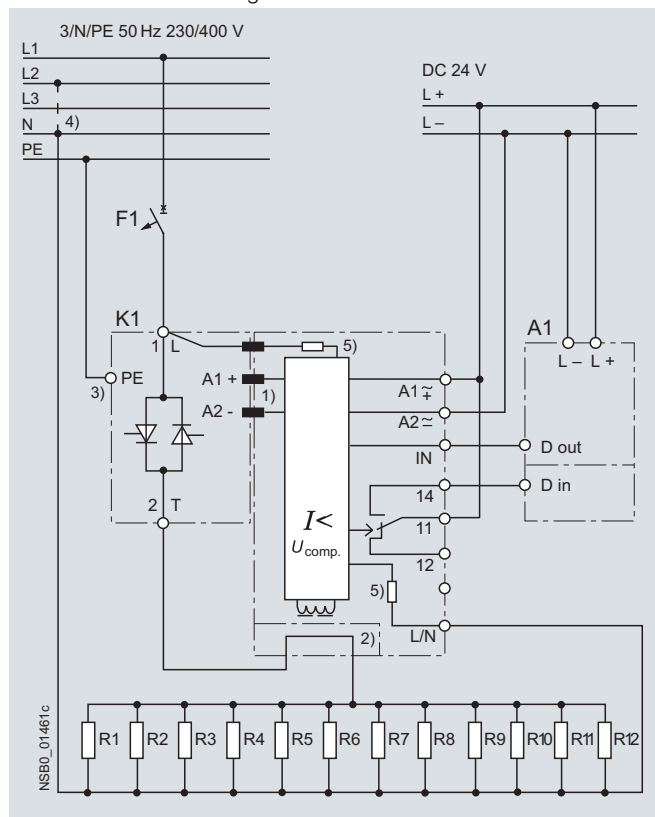

Power controller and regulator

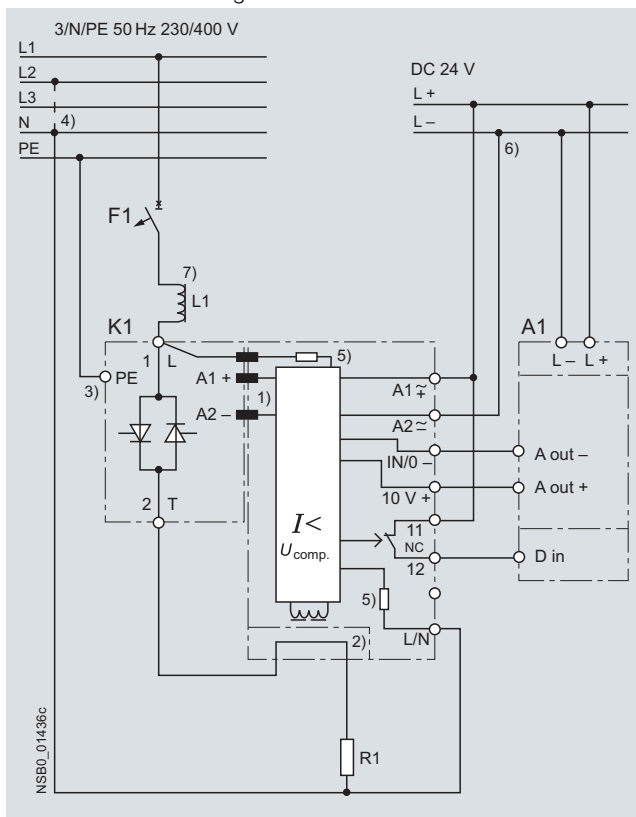

- 1) Internal connection to the solid-state relay/contacter.
- 2) Straight-through transformer.
- 3) Make PE/ground connection according to installation regulations.
- 4) Connection of L/N contact with:
 - 3RF29 ...-0.A.3 load monitoring/power controller on neutral conductor N (e. g. 230 V),
 - 3RF29 ...-0.A.6 load monitoring/power controller on a second phase (e. g. 400 V).

- 5) Voltage measuring not electrically isolated (3 MΩ per path).
- 6) Grounding of connection L- is recommended.
- 7) A 200 μH reactor must be used when operating with leading-edge phase in order to observe the limit values of the conducted interference voltage according to Class A.

4

Solid-State Switching Devices for Switching Motors

Solid-State Contactors

General data

Overview

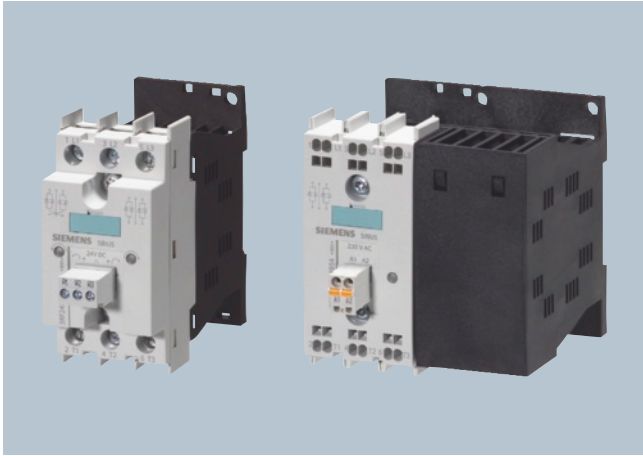

Solid-state contactors for switching motors

The solid-state contactors for switching motors are intended for frequently switching on and off three-phase current operating mechanisms up to 7.5 kW and reversing up to 3.0 kW. The devices are constructed with complete insulation and can be mounted directly on circuit breakers and SIRIUS overload relays, resulting in a very simple integration into motor feeders.

These three-phase solid-state contactors are equipped with a two-phase control which is particularly suitable for typical motor current circuits without connecting to the neutral conductor.

Important features:

- Insulated enclosure with integrated heat sink
- Degree of protection IP20
- Integrated mounting foot to snap on a standard mounting rail or for assembly onto a support plate
- Variety of connection methods
- Plug-in control connection
- Display via LEDs

Selecting solid-state contactors

The solid-state contactors are selected on the basis of details of the network, the load and the ambient conditions. As the solid-state contactors are already equipped with an optimally matched heat sink, the selection process is considerably simpler than that for solid-state relays.

The following procedure is recommended:

- Determine the rated current of the load and the mains voltage
- Select a solid-state contactor with the same or higher rated current than the load
- Testing the maximum permissible switching frequency based on the characteristic curves (see pages 4/56 and 4/62). To do this, the starting current, the starting time and the motor loaded in in the operating phase must be known.
- If the permissible switching frequency is under the desired frequency, it is possible to achieve an increase by overdimensioning the motor!

Design

Load feeders

There is no typical design of a load feeder with solid-state relays or solid-state contactors; instead, the great variety of connection methods and control voltages offers universal application opportunities. SIRIUS solid-state relays and solid-state contactors can be installed in fuseless or fused feeders, as required. There are special versions with which it is even possible to achieve short-circuit strength in a fuseless design.

Mounting regulations

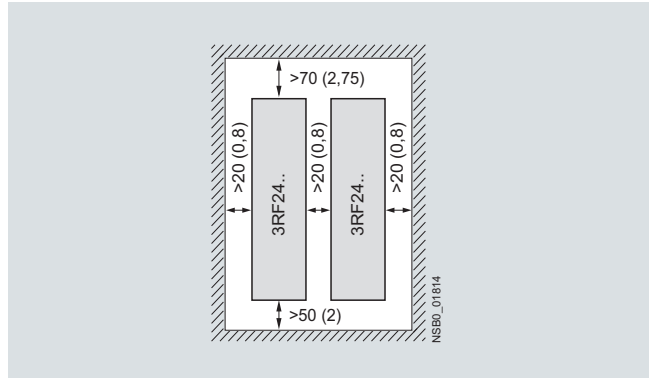

Clearances for stand-alone installation

Connection methods

All SIRIUS solid-state switching devices are characterized by the great variance of connection methods. You can choose between the following connection methods:

Screw connection

The screw connection system is the standard among industrial controls. Open terminals and a plus-minus screw are just two features of this technology. Two conductors of up to 6 mm² can be connected in just one terminal. As a result, loads of up to 50 A can be connected.

Spring-type terminals

This innovative technology manages without any screw connection. This means that very high vibration resistance is achieved. Two conductors of up to 2.5 mm² can be connected to each terminal. As a result, loads of up to 20 A can be dealt with.

Solid-State Switching Devices for Switching Motors

Solid-State Contactors

General data

Function

Switching functions

The contactors to switch motors are "Instantaneous switching", because this method is particularly suited for inductive loads. By distributing the ON point over the entire sine curve of the mains voltage, disturbances are reduced to a minimum.

Performance characteristics

The performance of the solid-state switching devices is substantially determined by the type of power semiconductors used and the internal design. In the case of the SIRIUS solid-state contactors and solid-state relays, only thyristors are used in place of less powerful Triacs.

Two of the most important features of thyristors are the blocking voltage and the maximum load integral:

Blocking voltage

Thyristors with a high blocking voltage can also be operated without difficulty in networks with high interference voltages. Separate protective measures, such as a protective circuit with a varistor, are not necessary in most cases.

For example, for the SIRIUS solid-state switching devices e. g. thyristors with 800 V blocking voltage are built in for operation in networks up to 230 V. Thyristors with up to 1600 V are used for power systems with higher voltages.

Maximum load integral

One of the purposes of specifying the maximum load integral (I^2t) is to determine the rating of the short-circuit protection. Only a large power semiconductor with a correspondingly high I^2t value can be given appropriate protection against destruction from a short-circuit by means of a protective device matched to the application. However, the SIRIUS solid-state switching devices are also characterized by the optimum matching of the thyristors (I^2t value) to the rated currents. The rated currents specified on the devices according to EN 60947-4-3 were confirmed by extensive testing.

You can find more information on the Internet at:

http://www.siemens.com/cd/is_schalten/html_76/schalt.htm

Integration

Notes on integration in the load feeders

The SIRIUS solid-state switching devices are very easy to integrate into the load feeders thanks to their industrial connection method and design.

Particular attention must however be paid to the circumstances of the installation and ambient conditions, as the performance of the solid-state switching devices is largely dependent on these. Depending on the version, certain restrictions must be observed. Detailed information about the minimum spacing can be found in the technical specifications and the product data sheets.

Despite the rugged power semiconductors that are used, solid-state switching devices respond more sensitively to short-circuits in the load feeder. Consequently, special precautions have to be taken against destruction, depending on the type of design.

Siemens generally recommends using SITOP semiconductor fuses. These fuses also provide protection against destruction in the event of a short-circuit even when the solid-state contactors and solid-state relays are fully utilized.

Alternatively, if there is lower loading, protection can also be provided by standard fuses or miniature circuit breakers. This protection is achieved by overdimensioning the solid-state switching devices accordingly. The technical specifications and the product data sheets contain details both about the solid-state fuse protection itself and about use of the SIRIUS devices with conventional protection equipment.

Semiconductor motor and reversing contactors can be easily combined with the 3RV motor starter protectors and 3RB2 overload relay from the SIRIUS modular system. Thus, fuseless and fuse motor feeders can be designed easily and in a space-saving manner.

Note:

The operation of wye-connected three-phase induction motors (especially with ratings < 1 kW) with electromechanical contactors can lead to very high EMC interference. Solid-state switching devices being used in the vicinity may be affected by this interference which lies above the permissible limit values.

In case of high EMC interference we recommend that motors up to 5.5 kW controlled by 3RT10 1. electromechanical contactors be equipped with EMC suppressor circuits. The best filtering effect is achieved with three-phase RC interference suppression modules such as 3RT19 16-1PA1 up to 400 V. Suitable modules for the contactors can be found in Chapter 3 under "Accessories and Spare Parts". Varistor interference suppression modules should not be used because they are unsatisfactory at filtering out rapid transients.

Solid-State Switching Devices for Switching Motors

Solid-State Contactors



3RF24 solid-state contactors, three-phase

Overview

These two-phase controlled, instantaneous switching solid-state contactors in the insulating enclosure are offered in 45 mm width to 5.2 A – and in 90 mm width to 16 A. This means that it is possible to operate motors up to 7.5 kW.

The devices can use a link module to directly connect to a circuit breaker. Direct mounting of a 3RB20 solid-state overload relay is also possible. Rapid-switching fuseless and fuse motor feeders can thereby be implemented in a time-saving manner.

Technical specifications

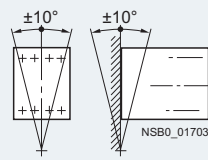
Order No.	3RF24 ...-1BB..	3RF24 ...-2BB..
General data		
Ambient temperature		
• During operation, derating from 40 °C	°C	-25 ... +60
• During storage	°C	-55 ... +80
Installation altitude	m	0 ... 1000; derating over 1000 m upon request
Shock resistance acc. to IEC 60068-2-27	g/ms	15/11
Vibration resistance acc. to IEC 60068-2-6	g	2
Degree of protection		IP20
Insulation strength at 50/60 Hz (main/control circuit to floor)	V rms	4000
Electromagnetic compatibility (EMC)		
• Emitted interference acc. to IEC 60947-4-3		
- Conducted interference voltage		Class A for industrial applications ¹⁾
- Emitted, high-frequency interference voltage		Class A for industrial applications
• Interference immunity		
- Electrostatic discharge acc. to IEC 61000-4-2 (corresponds to degree of severity 3)	kV	Contact discharge 4; air discharge 8; behavior criterion 2
- Induced RF fields acc. to IEC 61000-4-6	MHz	0.15 ... 80; 140 dBµV; behavior criterion 1
- Burst acc. to IEC 61000-4-4	kV	2/5 kHz; behavior criterion 1
- Surge acc. to IEC 61000-4-5	kV	Conductor - ground 2; conductor - conductor 1; behavior criterion 2
Connection type	 Screw terminals	 Spring-type terminals
Connection, main contacts		
• Conductor cross-section		
- Solid	mm ²	2 x (1.5 ... 2.5) ²⁾ , 2 x (2.5 ... 6) ²⁾
- Finely stranded with end sleeve	mm ²	2 x (1 ... 2.5) ²⁾ , 2 x (2.5 ... 6) ²⁾ , 1 x 10
- Finely stranded without end sleeve	mm ²	--
- Solid or stranded, AWG cables		2 x (AWG 14 ... 10)
• Stripped length	mm	10
• Terminal screw		M4
- Tightening torque	Nm lb.in	2 ... 2.5 18 ... 22
Connection, auxiliary/control contacts		
• Conductor cross-section		
- With/without end sleeve	mm AWG	1 x (0.5 ... 2.5), 2 x (0.5 ... 1.0) AWG 20 ... 12
• Stripped length	mm	7
• Terminal screw		M3
- Tightening torque, (∅ 3.5, PZ 1)	Nm lb.in	0.5 ... 0.6 4.5 ... 5.3
Permissible mounting positions		
		

¹⁾ These products were built as Class A devices. The use of these devices in residential areas could result in lead in radio interference. In this case these may be required to introduce additional interference suppression measures.

²⁾ If two different conductor cross-sections are connected to one clamping point, both cross-sections must lie in the range specified. If identical cross-sections are used, this restriction does not apply.

Solid-State Switching Devices for Switching Motors

Solid-State Contactors

3RF24 solid-state contactors, three-phase

Order No.	Fuseless design with motor starter protector CLASS 10					
	Rated operational current I_{AC-53} ¹⁾ acc. to IEC 60947-4-2			Power loss at I_{AC-53} at 40 °C	Short-circuit protection with type of coordination "1" at an operational voltage of U_e to 440 V	
	at 40 °C	UL/CSA, at 50 °C	at 60 °C		Motor starter protector	I_q
A	A	A	W	Type	kA	
3RF24 05-.BB..	5.2 (4.5)	4.6 (4.0)	4.2 (3.5)	10 (8)	3RV1 021-1GA10	50
3RF24 10-.BB..	9.2	8.4	7.6	16	3RV1 021-1JA10	20
3RF24 12-.BB..	12.5	11.5	10.5	22	3RV1 021-1KA10	5
3RF24 16-.BB..	16	14	12.5	28	3RV1 021-4AA10	5

Order No.	Fused design with directly connected 3RB20 overload relay				Minimum load current	Max. leakage current	Rated impulse withstand capacity I_{tsm}	I^2t value
	Rated operational current I_{AC-53} acc. to IEC 60947-4-2			Power loss at I_{AC-53} at 40 °C				
	at 40 °C	UL/CSA, at 50 °C	at 60 °C		A	A	A	A ² s
A	A	A	W	A	A	A	A ² s	
3RF24 05-.BB.4	4	3.6	3.2	7	0.5	10	200	200
3RF24 05-.BB.6							600	1800
3RF24 10-.BB..	7.8	7	6.2	13	0.5	10	600	1800
3RF24 12-.BB.4	9.5	8.5	7.6	16	0.5	10	1200	7200
3RF24 12-.BB.6							1150	6600
3RF24 16-.BB..	11	10	9	18	0.5	10	1150	6600

Type	3RF24 ..-BB.4		3RF24 ..-BB.6	
Main circuit				
Controlled phases	Two-phase		Two-phase	
Rated operational voltage U_e	V	48 ... 460	48 ... 600	
• Operating range	V	40 ... 506	40 ... 660	
• Rated frequency	Hz	50/60 ± 10 %	50/60 ± 10 %	
Rated insulation voltage U_i	V	600	600	
Rated impulse withstand voltage U_{imp}	kV	6	6	
Blocking voltage	V	1200	1600	
Rate of voltage rise	V/μs	1000	1000	

Type	3RF24 ..-BB0.		3RF24 ..-BB2.	
Control circuit				
Method of operation	DC operation		AC operation	
Rated control supply voltage U_s	V	24 acc. to EN 61131-2	110 ... 230	
Rated frequency of the control supply voltage	Hz	--	50/60 ± 10 %	
Control supply voltage, max.		30	253	
Typical actuating current	mA	20	15	
Response voltage	V	15	90	
Drop-out voltage	V	5	< 40	
Operating times				
• ON-delay	ms	1	5	
• OFF-delay	ms	1 + max. one half-wave	30 + max. one half-wave	

1) The reduced values in brackets apply to a directly mounted circuit breaker and simultaneous butt-mounting.

Solid-State Switching Devices for Switching Motors

Solid-State Contactors

3RF24 solid-state contactors, three-phase

Fused version with semiconductor protection (similar to type of coordination "2")¹⁾

The semiconductor protection for the 3RF24 controls can be used with different protective devices. Siemens recommends the use of special SITOR semiconductor fuses. The table below lists the maximum permissible fuses for each 3RF24 control.

If a fuse is used with a higher rated current than specified, semiconductor protection is no longer guaranteed. However, smaller fuses with a lower rated current up to a lower rated current of the load can only be used after the behavior of the existing load alternation has been tested.

Order No.	All-range fuses gR		Semiconductor fuses aR			Cable and line protection fuses					
	LV HRC design	Cylindr. design	LV HRC design	Cylindrical design		LV HRC design	Cylindrical design				
	SITOR 3NE1	NEOZED 3SE1 ²⁾	SITOR 3NE8	10 mm x 38 mm SITOR 3NC1	14 mm x 51 mm SITOR 3NC1	22 mm x 58 mm SITOR 3NC2	gG 3NA3	10 mm x 38 mm gG 3NW6	14 mm x 51 mm gG 3NW6	22 mm x 58 mm gG 3NW6	DIAZED quick 5SB1
Operational voltage U_e up to 506 V											
3RF24 05-.BB.4	3NE1 813-0	5SE1 320	3NE8 015-1	3NC1 020	3NC1 415	3NC2 220	3NA3 801-6	3NW6 001-1	3NW6 101-1	--	5SB1 71
3RF24 10-.BB.4	3NE1 802-0	5SE1 335	3NE8 020-1	3NC1 032	3NC1 450	3NC2 263	3NA3 805-6	3NW6 005-1	3NW6 105-1	3NW6 205-1	5SB3 11
3RF24 12-.BB.4	3NE1 818-0	5SE1 363	3NE8 021-1	3NC1 032	3NC1 450	3NC2 280	3NA3 810-6	3NW6 010-1	3NW6 116-1	3NW6 210-1	5SB3 21
3RF24 16-.BB.4	3NE1 818-0	5SE1 363	3NE8 022-1	3NC1 032	3NC1 450	3NC2 280	3NA3 812-6	3NW6 010-1	3NW6 116-1	3NW6 210-1	5SB3 22
Operational voltage U_e up to 660 V											
3RF24 05-.BB.6	3NE1 813-0	--	3NE8 015-1	3NC1 016	3NC1 420	3NC2 220	3NA3 801-6	--	--	--	--
3RF24 10-.BB.6	3NE1 803-0	--	3NE8 018-1	3NC1 032	3NC1 450	3NC2 250	3NA3 805-6	--	--	--	--
3RF24 12-.BB.6	3NE1 817-0	--	3NE8 021-1	3NC1 032	3NC1 450	3NC2 280	3NA3 810-6	--	--	--	--
3RF24 16-.BB.6	3NE1 817-0	--	3NE8 022-1	3NC1 032	3NC1 450	3NC2 280	3NA3 812-6	--	--	--	--

Suitable fuse holders, fuse bases and controls can be found in Catalog LV 1, Chapter 19.

¹⁾ Type of coordination "2" according to EN 60947-4-1:
In the event of a short-circuit, the controls in the load feeder must not endanger persons or the installation. They must be suitable for further operation. For fused configurations, the protective device must be replaced.

²⁾ For use only with operational voltage U_e up to 400 V.

Characteristic curves

Load diagram of motor

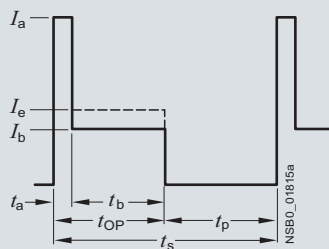

Operating data of motor

- I_a Direct starting current
- I_e Rated operational current
- I_b Operational current
- t_a Starting time
- t_b Operating time
- t_p Interval time
- t_{OP} ON period
- t_s Operating cycle

$$OP [\%] = \frac{t_{OP}}{t_s} \times 100 \%$$

Solid-State Switching Devices for Switching Motors

Solid-State Contactors

3RF24 solid-state contactors, three-phase

Maximum permissible switching frequency depending on the starting time t_a and the ON period t_{OP}

4

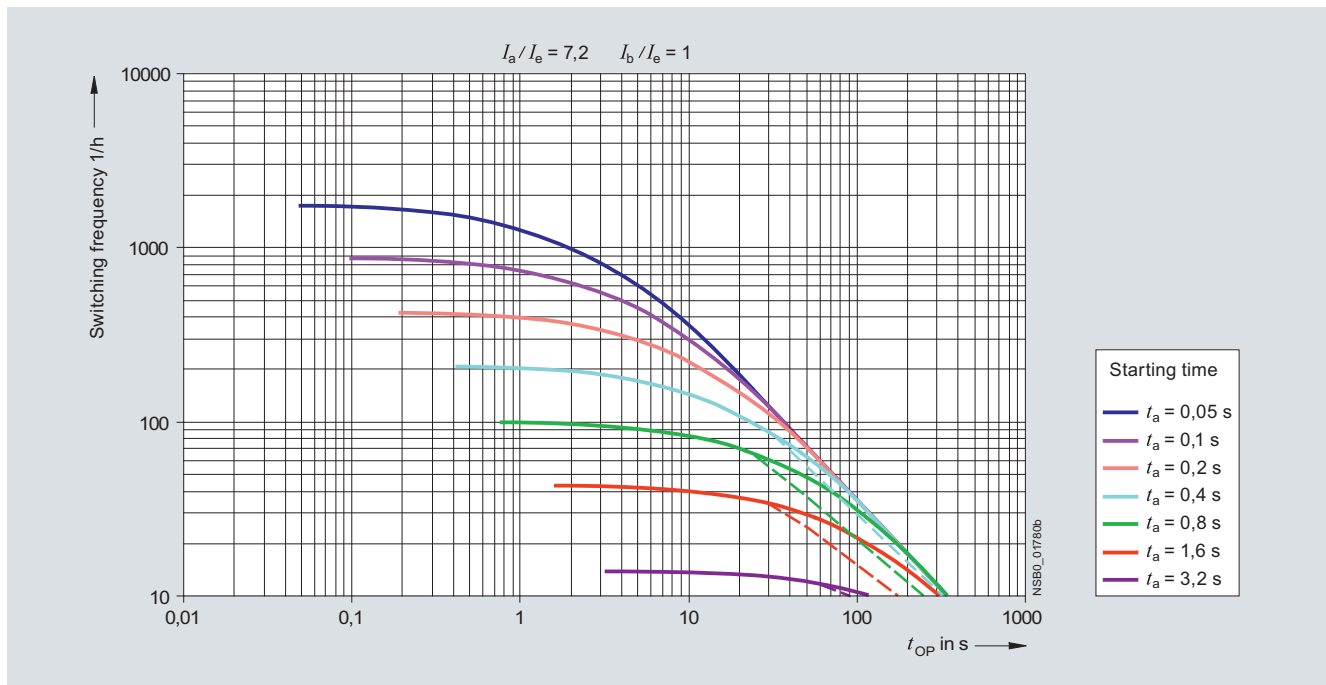

For motors with a starting current of 4 to 7.2 times the rated current and with a full load (the dashed curves apply to the high currents during operation with motor starter protector)

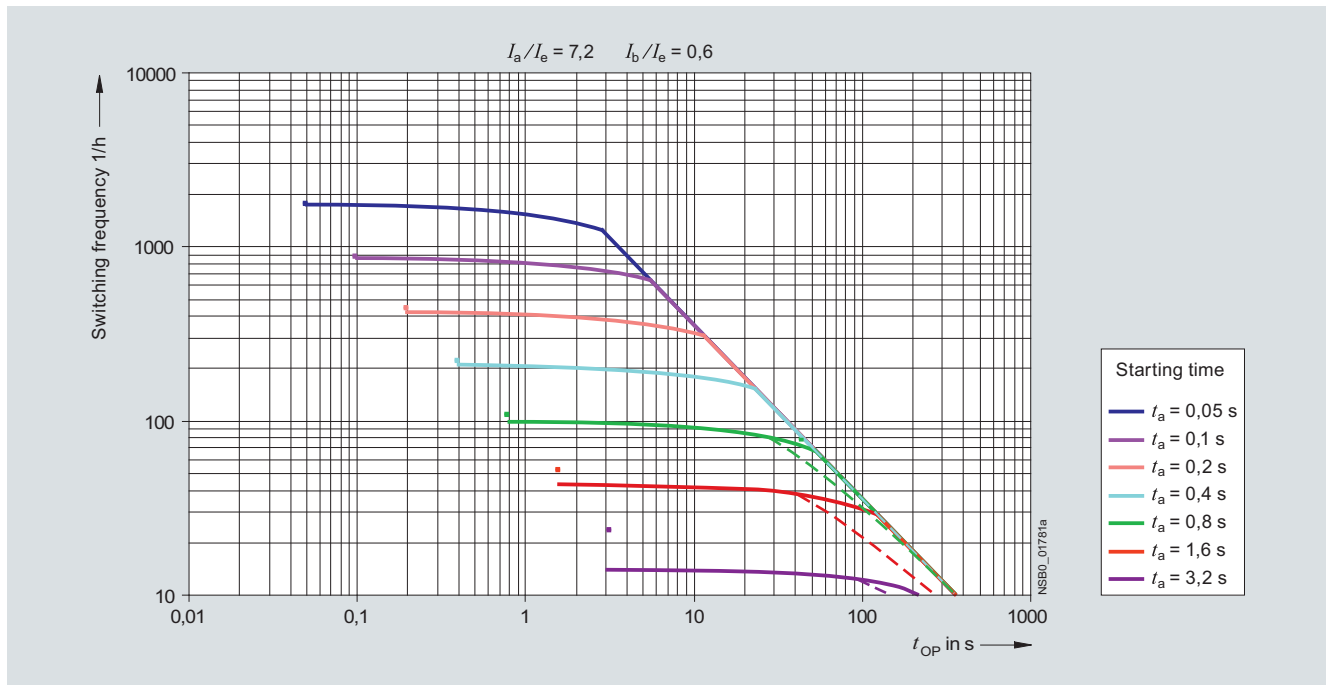

For motors with a starting current of 4 to 7.2 times the rated current and with 60 % load (the dashed curves apply to the high currents during operation with motor starter protector)

Solid-State Switching Devices for Switching Motors

Solid-State Contactors

3RF24 solid-state contactors, three-phase

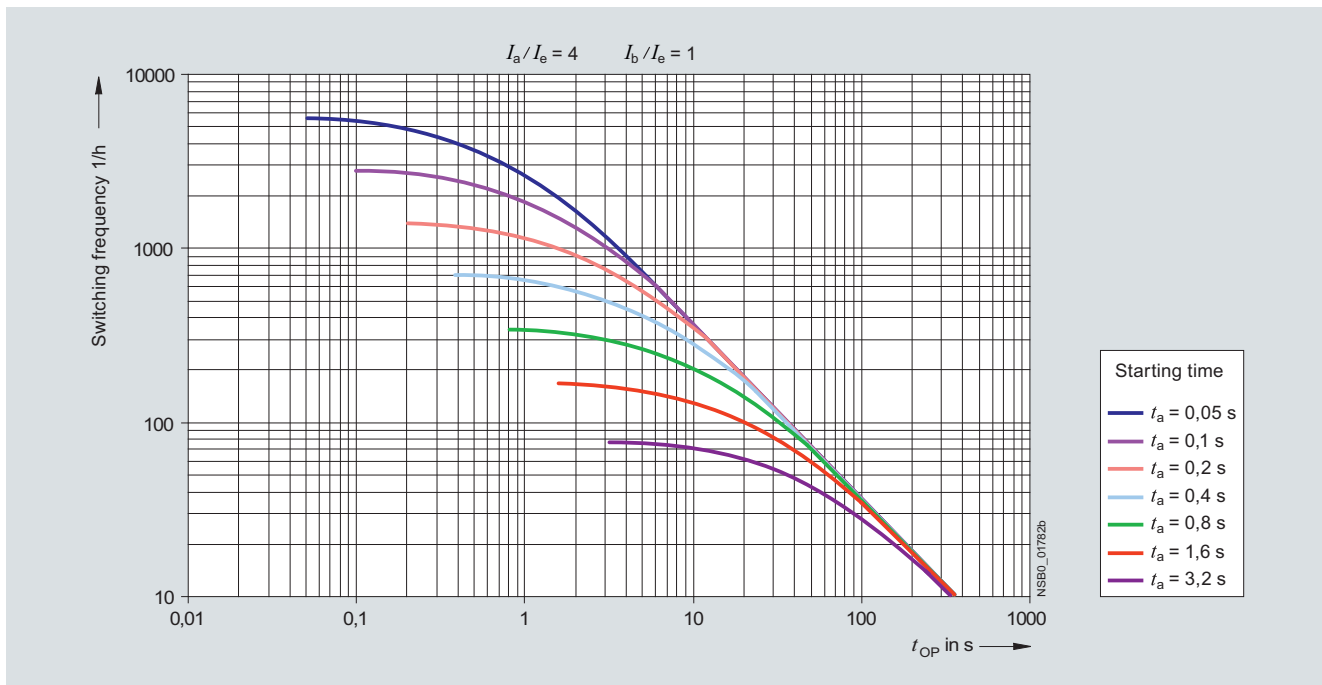

For motors with a starting current of up to 4 times the rated current and with a full load

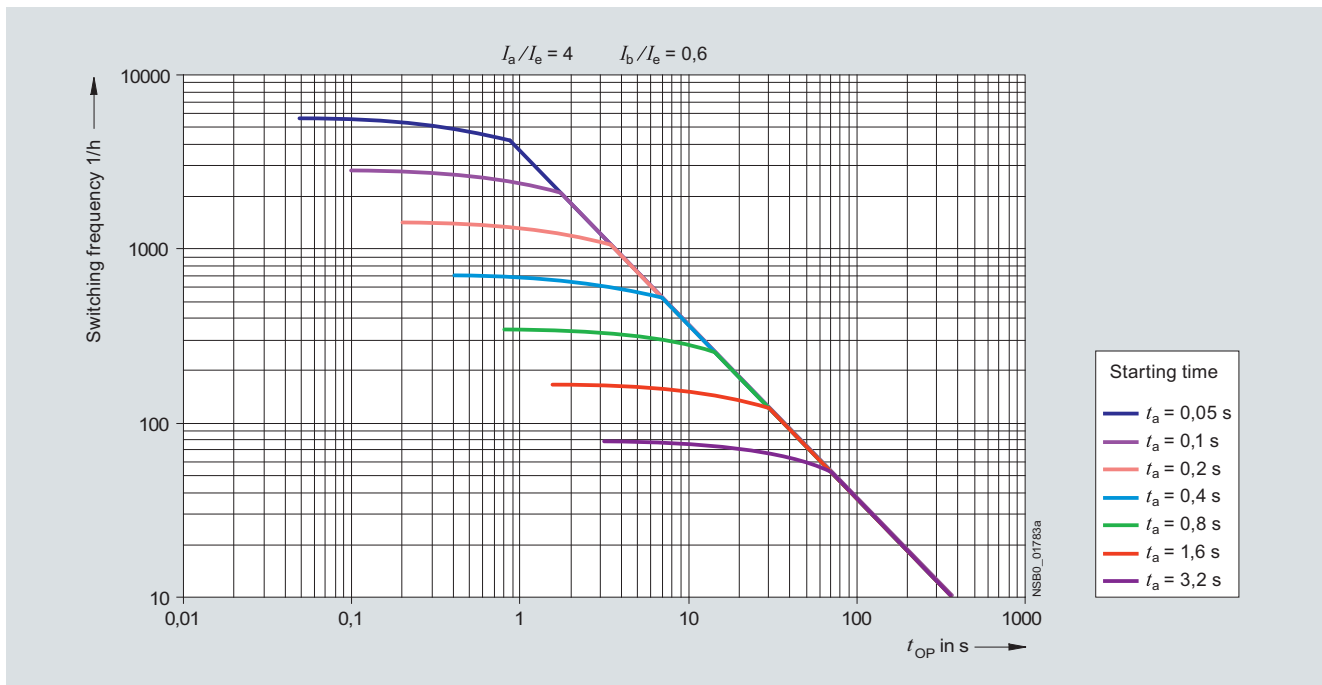

For motors with a starting current of up to 4 times the rated current and with a 60 % load

4

Solid-State Switching Devices for Switching Motors

Solid-State Contactors

3RF24 solid-state contactors, three-phase

Dimensional drawings

Screw terminals

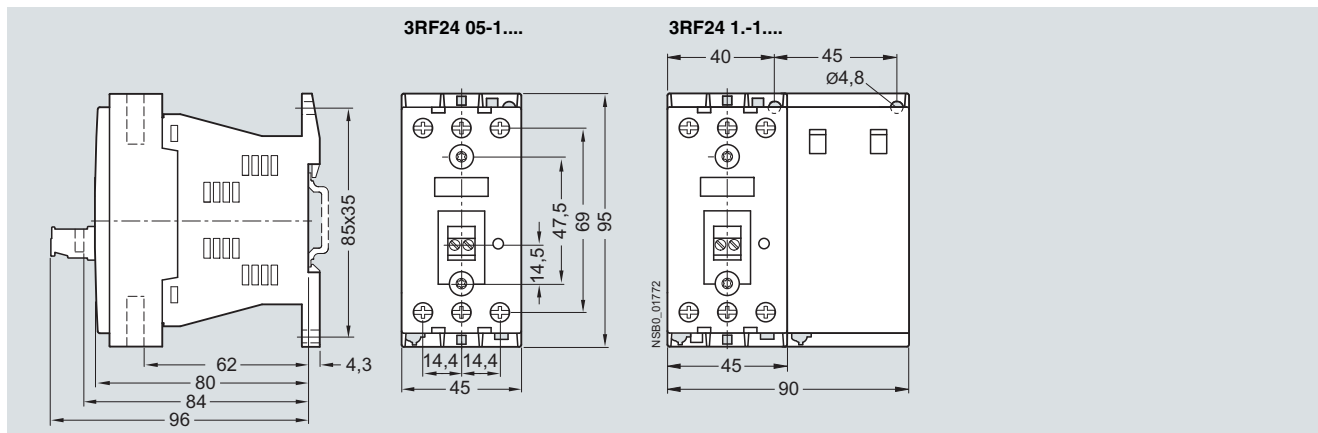

Spring-type terminals

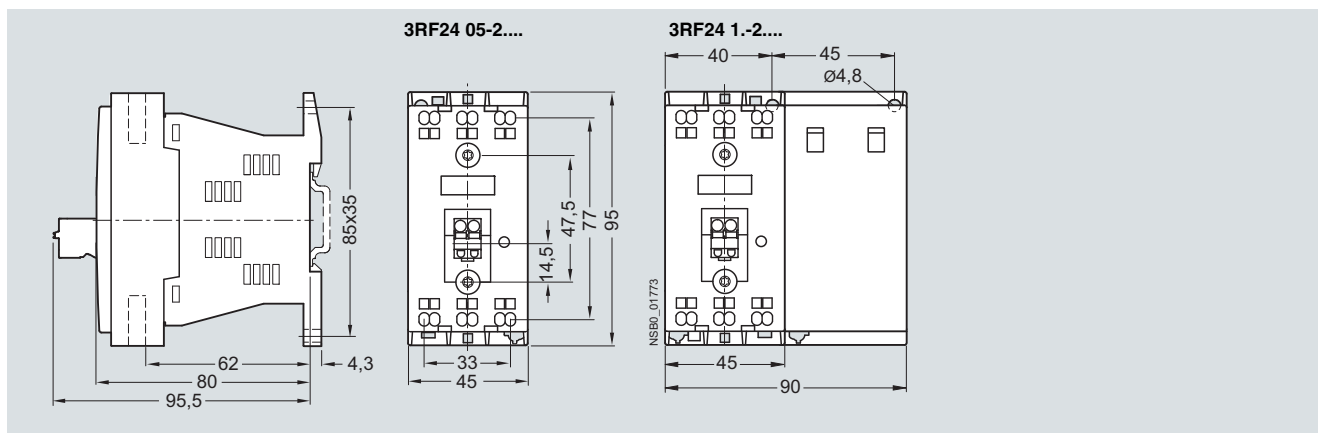

Schematics

Two-phase controlled,
DC control supply voltage

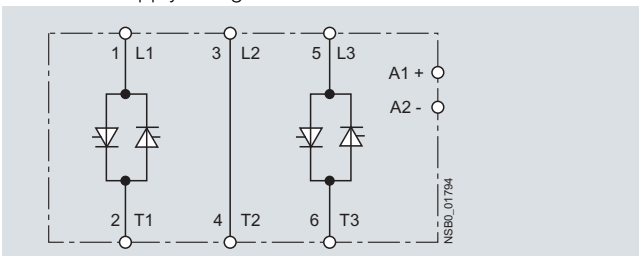

Two-phase controlled,
AC control supply voltage

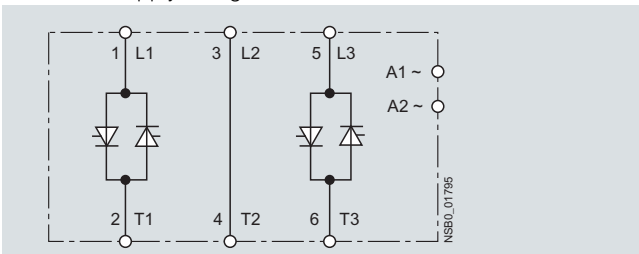

Sample schematic

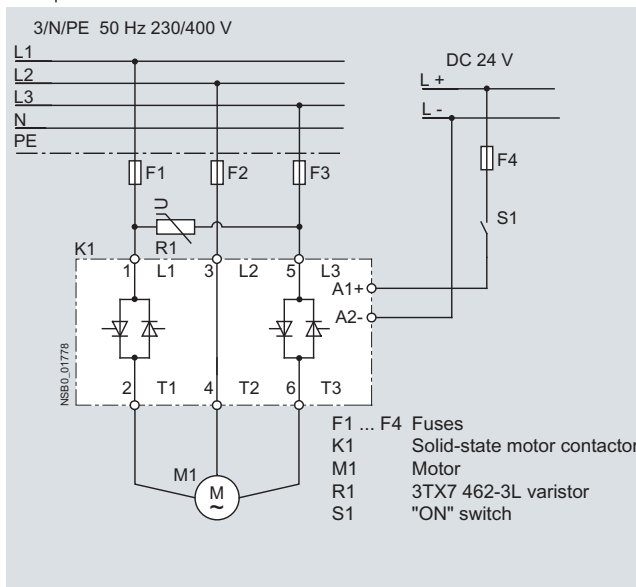

4

Solid-State Switching Devices for Switching Motors

Solid-State Contactors

3RF24 solid-state reversing contactors,
three-phase

Overview

The integration of four conducting paths to a reverse switch, combined in one enclosure makes this device a particularly compact solution. Compared to conventional systems, for which two contactors are required, it is possible to save up to 50 % width with the three-phase reversing contactors. Devices with 45 mm width cover motors up to 2.2 kW – and those with 90 mm width up to 3 kW.

Due to the integration into the SIRIUS modular system, it is possible to make a connection to a SIRIUS motor starter protector using a link module or with a 3RB20 solid-state overload relay without additional steps. It is possible to mount fuseless or fused motor feeders easily and quickly.

Technical specifications

Order No.	3RF24 ...1BD..	
General data		
Ambient temperature		
• During operation, derating from 40 °C	°C	-25 ... +60
• During storage	°C	-55 ... +80
Installation altitude	m	0 ... 1000; derating over 1000 m upon request
Shock resistance acc. to IEC 60068-2-27	g/ms	15/11
Vibration resistance acc. to IEC 60068-2-6	g	2
Degree of protection		IP20
Insulation strength at 50/60 Hz (main/control circuit to floor)	V rms	4000
Electromagnetic compatibility (EMC)		
• Emitted interference acc. to IEC 60947-4-3		
- Conducted interference voltage		Class A for industrial applications ¹⁾
- Emitted, high-frequency interference voltage		Class A for industrial applications
• Interference immunity		
- Electrostatic discharge acc. to IEC 61000-4-2 (corresponds to degree of severity 3)	kV	Contact discharge 4; air discharge 8; behavior criterion 2
- Induced RF fields acc. to IEC 61000-4-6	MHz	0.15 ... 80; 140 dBµV; behavior criterion 1
- Burst acc. to IEC 61000-4-4	kV	2/5 kHz; behavior criterion 1
- Surge acc. to IEC 61000-4-5 ²⁾	kV	Conductor - ground 2; conductor - conductor 1; behavior criterion 2
Connection type	⊕ Screw terminals	
Connection, main contacts		
• Conductor cross-section		
- Solid	mm ²	2 x (1.5 ... 2.5) ³⁾ , 2 x (2.5 ... 6) ³⁾
- Finely stranded with end sleeve	mm ²	2 x (1 ... 2.5) ³⁾ , 2 x (2.5 ... 6) ³⁾ , 1 x 10
- Finely stranded without end sleeve	mm ²	--
- Solid or stranded, AWG cables		2 x (AWG 14 ... 10)
• Stripped length	mm	10
• Terminal screw		M4
- Tightening torque	Nm lb.in	2 ... 2.5 18 ... 22
Connection, auxiliary/control contacts		
• Conductor cross-section		
- With/without end sleeve	mm AWG	1 x (0.5 ... 2.5), 2 x (0.5 ... 1.0) AWG 20 ... 12
• Stripped length	mm	7
• Terminal screw		M3
- Tightening torque, (∅ 3.5, PZ 1)	Nm lb.in	0.5 ... 0.6 4.5 ... 5.3
Permissible mounting positions		

¹⁾ These products were built as Class A devices. The use of these devices in residential areas could result in lead in radio interference. In this case these may be required to introduce additional interference suppression measures.

²⁾ To maintain the values, a 3TX7 462-3L surge suppressor (see [Catalog LV 1, Chapter 3, page 3/119](#)) should be used between the phases L1 and L3 as close as possible to the switchgear.

³⁾ If two different conductor cross-sections are connected to one clamping point, both cross-sections must lie in the range specified. If identical cross-sections are used, this restriction does not apply.

Solid-State Switching Devices for Switching Motors

Solid-State Contactors

3RF24 solid-state reversing contactors, three-phase

Order No.	Fuseless design with motor starter protector CLASS 10			Power loss at I_{AC-53}	Short-circuit protection with type of coordination "1" at an operational voltage of U_e to 440 V	
	Rated operational current I_{AC-53} ¹⁾ acc. to IEC 60947-4-2	UL/CSA, at 50 °C	at 60 °C		Motor starter protector	I_q
	at 40 °C			at 40 °C	Type	kA
3RF24 03-.BD.4	3.8 (3.4)	3.5 (3.1)	3.2 (2.8)	7 (6)	3RV1 021-1FA10	50
3RF24 05-.BD.4	5.4 (4.8)	5 (4.3)	4.6 (3.8)	9 (8)	3RV1 021-1GA10	50
3RF24 10-.BD.4	7.4	6.8	6.2	13	3RV1 021-1JA10	10

Order No.	Fused design with directly connected 3RB20 overload relay			Power loss at I_{AC-53}	Minimum load current	Max. leakage current	Rated impulse withstand capacity I_{tsm}	I^2t value
	Rated operational current I_{AC-53} acc. to IEC 60947-4-2	UL/CSA, at 50 °C	at 60 °C					
	at 40 °C			at 40 °C	A	mA	A	A ² s
3RF24 03-.BD.4	3.8	3.5	3.2	6	0.5	10	200	200
3RF24 05-.BD.4	5.4	5	4.6	8	0.5	10	600	1800
3RF24 10-.BD.4	7.4	6.8	6.2	16	0.5	10	600	1800

Type	3RF24 ...-BD.4	
Main circuit		
Controlled phases	Two-phase	
Rated operational voltage U_e²⁾	V	48 ... 460
• Operating range	V	40 ... 506
• Rated frequency	Hz	50/60 ± 10 %
Rated insulation voltage U_i	V	600
Rated impulse withstand voltage U_{imp}	kV	6
Blocking voltage	V	1200
Rate of voltage rise	V/μs	1000

Type	3RF24 ...-BD0.		3RF24 ...-BD2.	
Control circuit				
Method of operation	DC operation		AC operation	
Rated control supply voltage U_s	V	24 acc. to EN 61131-2	110 ... 230	
Rated frequency of the control supply voltage	Hz	--	50/60 ± 10 %	
Control supply voltage, maximum	V	30	253	
Typical actuating current	mA	15	10	
Response voltage	V	15	90	
Drop-out voltage	V	5	< 40	
Operating times				
• ON-delay	ms	5	20	
• OFF-delay	ms	5 + max. one half-wave	10 + max. one half-wave	
• Interlocking time	ms	60 ... 100	50 ... 100	

1) The reduced values in brackets apply to a directly mounted circuit breaker and simultaneous butt-mounting.

2) To reduce the risk of a phase short circuit due to overvoltage, we recommend using a varistor type 3TX7 462-3L between the phases L1 and L3 and as close as possible to the switchgear. We recommend a design with semiconductor protection as short-circuit protection.

Solid-State Switching Devices for Switching Motors

Solid-State Contactors

3RF24 solid-state reversing contactors, three-phase

Fused version with semiconductor protection (similar to type of coordination "2")¹⁾

The semiconductor protection for the 3RF24 controls can be used with different protective devices. Siemens recommends the use of special SITOR semiconductor fuses. The table below lists the maximum permissible fuses for each 3RF24 control.

If a fuse is used with a higher rated current than specified, semiconductor protection is no longer guaranteed. However, smaller fuses with a lower rated current up to a lower rated current of the load can only be used after the behavior of the existing load alternation has been tested.

Order No.	All-range fuses gR		Semiconductor fuses aR				Cable and line protection fuses			
	LV HRC design	Cylindr. design	LV HRC design	Cylindrical design			LV HRC design	Cylindrical design		
	SITOR 3NE1	NEOZED 3SE1 ²⁾	SITOR 3NE8	10 mm x 38 mm SITOR 3NC1	14 mm x 51 mm SITOR 3NC1	22 mm x 58 mm SITOR 3NC2	gG 3NA3	10 mm x 38 mm gG 3NW6	14 mm x 51 mm gG 3NW6	DIAZED quick 5SB1
Operational voltage U_e up to 506 V										
3RF24 03-.BD..	3NE1 813-0	5SE1 335	3NE8 015-1	3NC1 020	3NC1 415	3NC2 220	3NA3 801-6	3NW6 001-1	3NW6 101-1	5SB1 71
3RF24 05-.BD..	3NE1 802-0	5SE1 335	3NE8 020-1	3NC1 032	3NC1 450	3NC2 263	3NA3 805-6	--	--	5SB3 11
3RF24 10-.BD..	3NE1 802-0	5SE1 335	3NE8 020-1	3NC1 032	3NC1 450	3NC2 263	3NA3 805-6	--	--	5SB3 11

Suitable fuse holders, fuse bases and controls can be found in Catalog LV 1, Chapter 19.

- 1) Type of coordination "2" according to EN 60947-4-1:
In the event of a short-circuit, the controls in the load feeder must not endanger persons or the installation. They must be suitable for further operation. For fused configurations, the protective device must be replaced.
- 2) For use only with operational voltage U_e up to 400 V.

Characteristic curves

Load diagram of motor

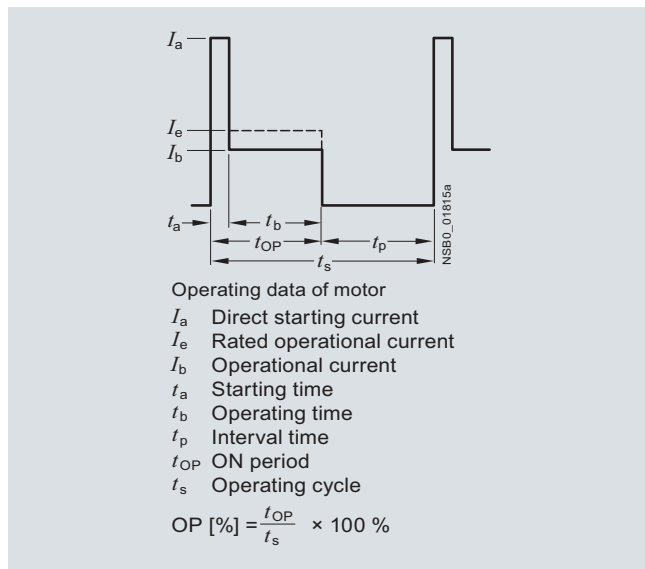

Solid-State Switching Devices for Switching Motors

Solid-State Contactors

3RF24 solid-state reversing contactors, three-phase

Maximum permissible switching frequency depending on the starting time t_a and the ON period t_{OP}

4

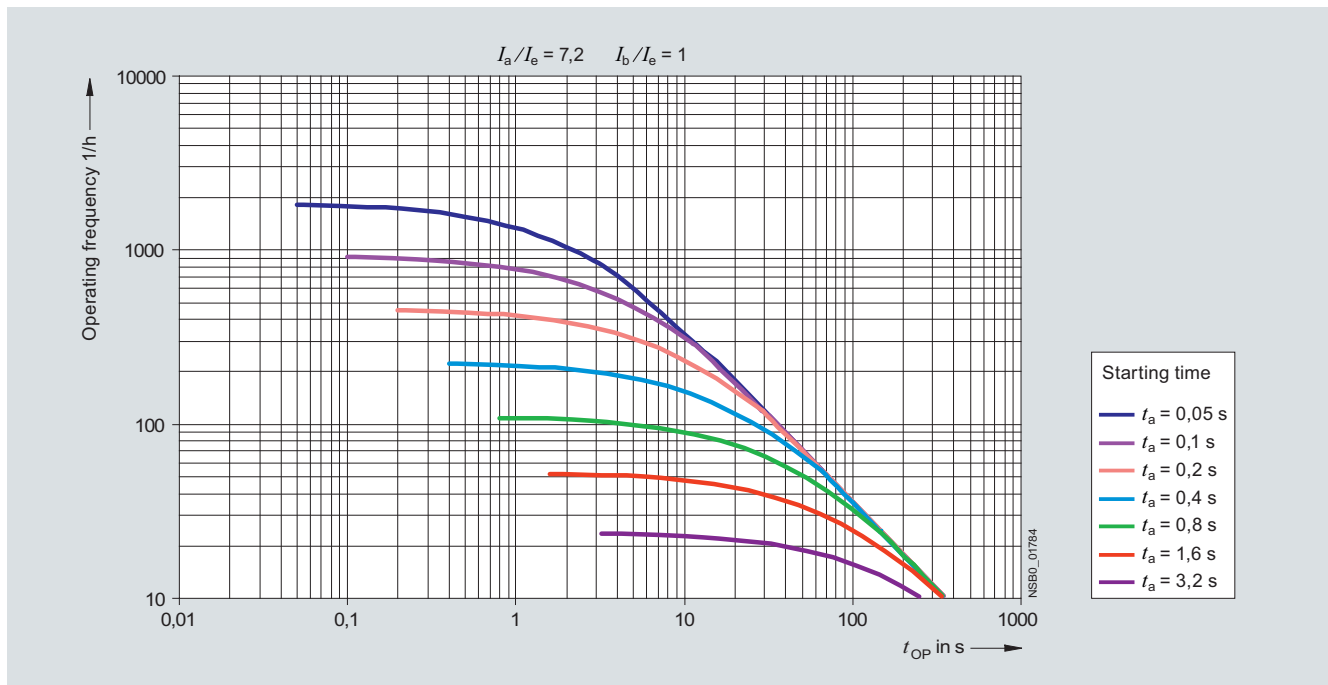

For motors with a starting current of 4 to 7.2 times the rated current and with a full load

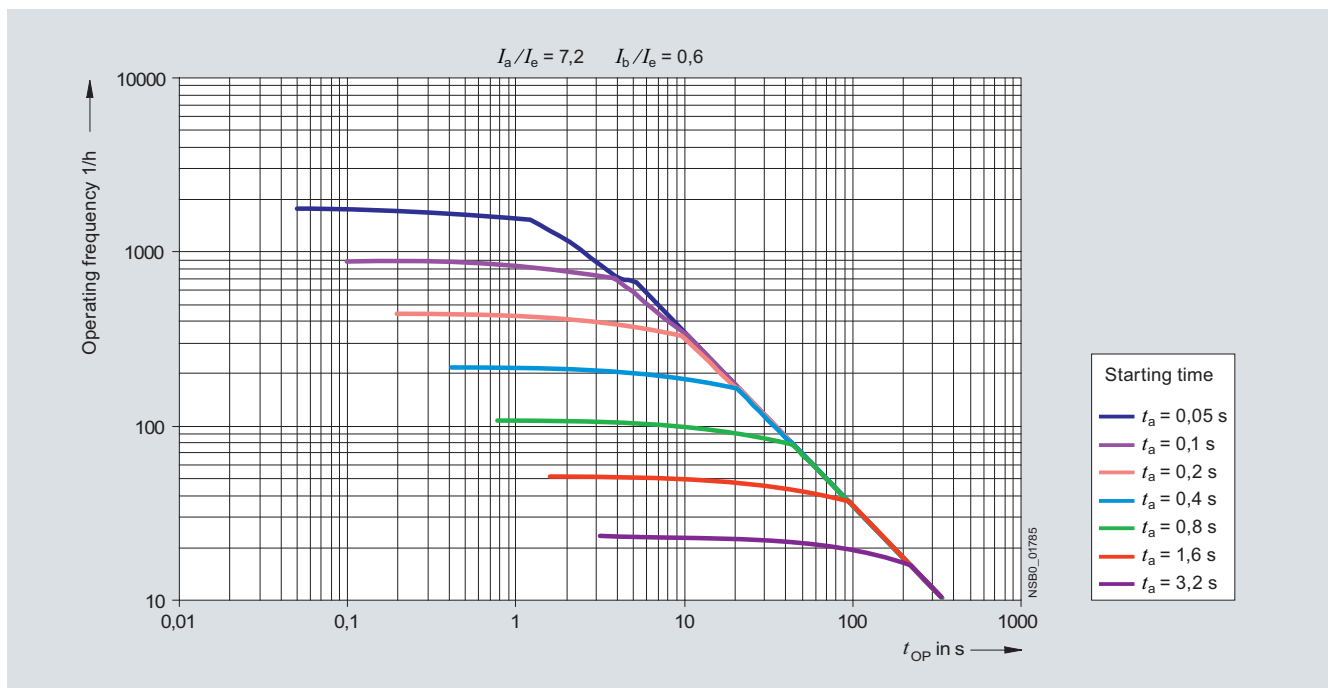

For motors with a starting current of 4 to 7.2 times the rated current and with a 60 % load

Solid-State Switching Devices for Switching Motors

Solid-State Contactors

3RF24 solid-state reversing contactors, three-phase

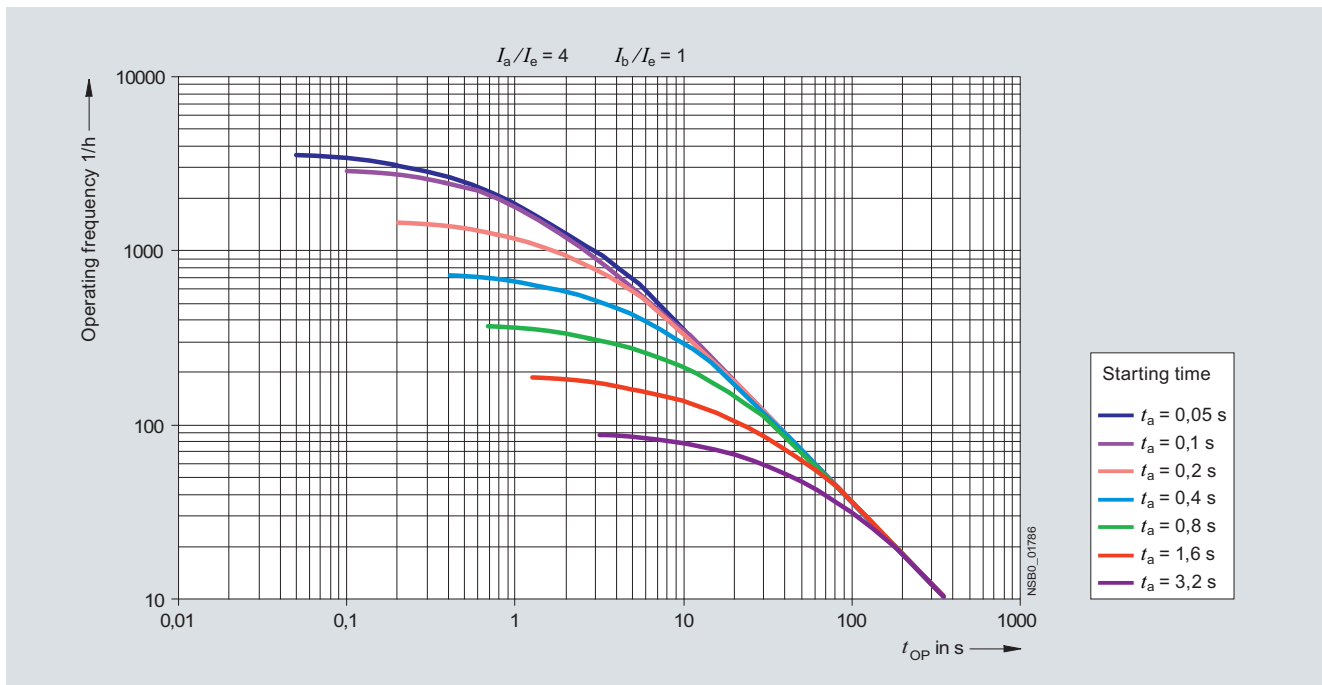

For motors with a starting current of up to 4 times the rated current and with a full load

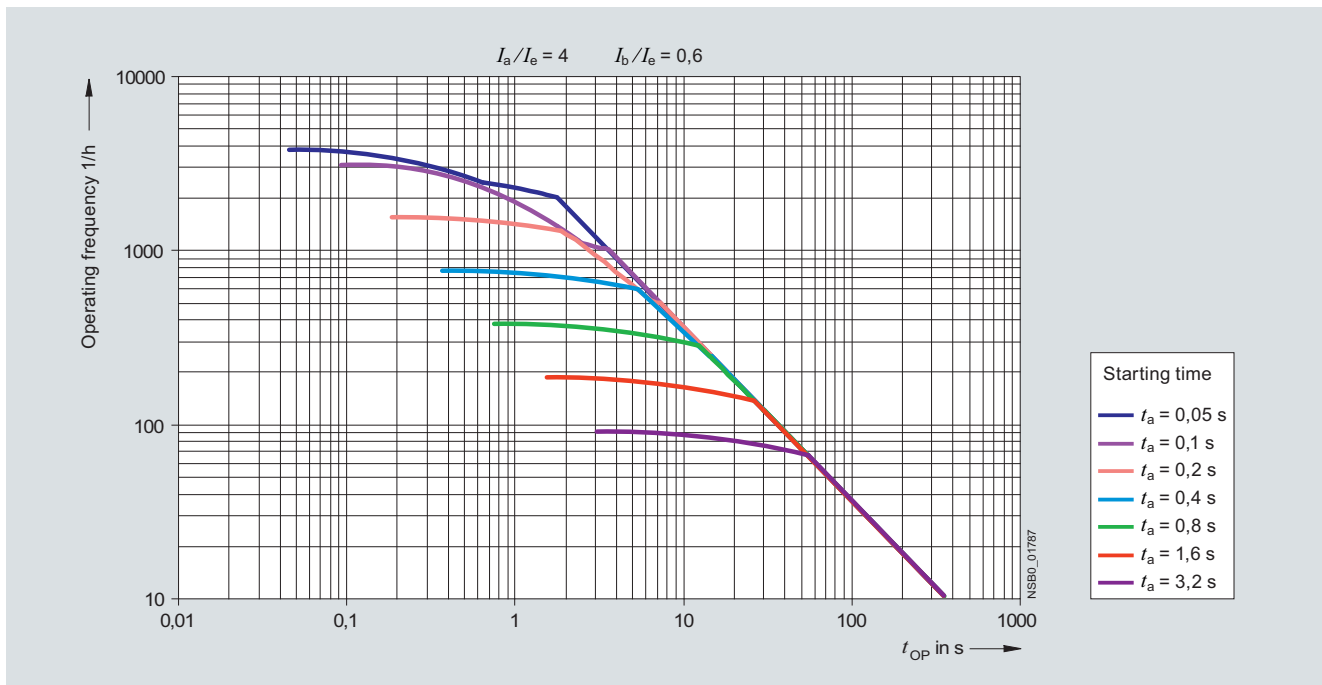

For motors with a starting current of up to 4 times the rated current and with a 60 % load

4

Solid-State Switching Devices for Switching Motors

Solid-State Contactors

3RF24 solid-state reversing contactors, three-phase

Dimensional drawings

Screw terminals

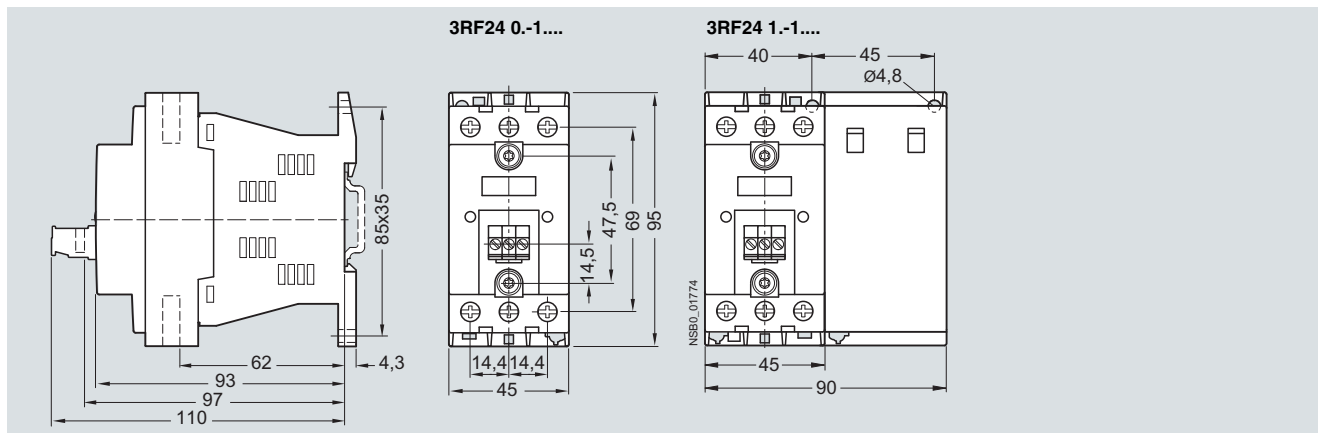

Schematics

Two-phase controlled,
DC control supply voltage

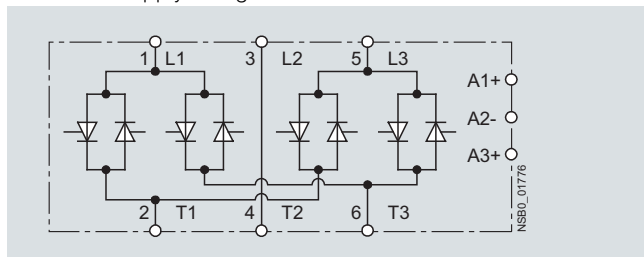

Two-phase controlled,
AC control supply voltage

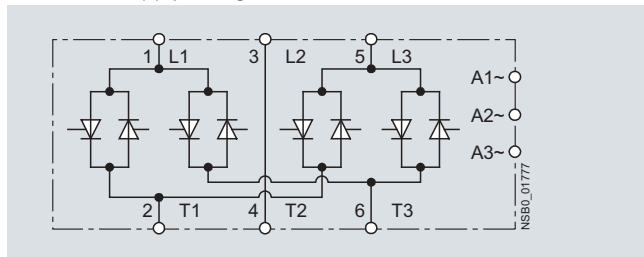

Sample schematic

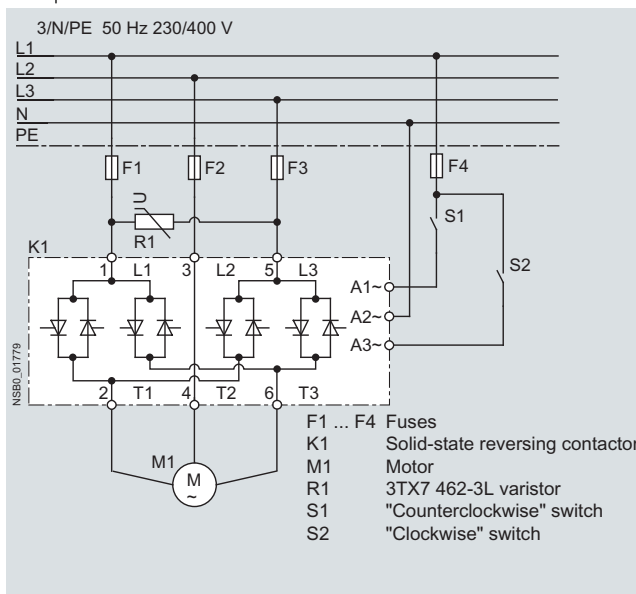

4

Protection Equipment



5/2 Introduction

3RV Motor Starter Protectors/Circuit Breakers up to 100 A

- General data
- 5/5 - Overview
 - 5/6 - Design
 - 5/8 - Function
 - 5/8 - Configuration
 - 5/11 - Technical specifications
 - 5/21 - Characteristic curves
 - 5/22 - Dimensional drawings
 - 5/25 - Schematics
 - 5/25 - More information
- Accessories
- Mountable accessories
- 5/26 - Overview
 - 5/27 - Technical specifications
 - 5/28 - Schematics
- Rotary operating mechanisms
- 5/30 - Overview
 - 5/31 - Technical specifications
 - 5/31 - Schematics
- Mounting accessories
- 5/32 - Overview
 - 5/32 - Technical specifications
- Project planning aids
- 5/33 - Dimensional drawings

3RV Molded Case Motor Starter Protectors up to 800 A

- General data
- 5/40 - Overview
 - 5/41 - Design
 - 5/42 - Function
 - 5/43 - Configuration
 - 5/44 - Technical specifications
 - 5/46 - Characteristic curves
 - 5/47 - Dimensional drawings
 - 5/48 - Schematics
- Accessories
- Mountable accessories
- 5/49 - Technical specifications
 - 5/49 - Schematics
- Project planning aids
- 5/50 - Dimensional drawings

Overload Relays

- General data
- 5/55 - Overview
- 3RU1 Thermal Overload Relays
- 3RU11 for standard applications
- 5/59 - Overview
 - 5/59 - Design
 - 5/60 - Function
 - 5/61 - Technical specifications
 - 5/66 - Characteristic curves
 - 5/67 - Dimensional drawings
 - 5/68 - Schematics
- Accessories
- 3RB2 Solid-State Overload Relays
- 3RB20, 3RB21 for standard applications
- 5/70 - Overview
 - 5/70 - Design
 - 5/71 - Function
 - 5/72 - Technical specifications
 - 5/77 - Characteristic curves
 - 5/78 - Dimensional drawings
 - 5/79 - Schematics
- 3RB22, 3RB23 for high-feature applications
- 5/80 - Overview
 - 5/81 - Design
 - 5/82 - Function
 - 5/84 - Technical specifications
 - 5/89 - Characteristic curves
 - 5/90 - Dimensional drawings
 - 5/92 - Schematics
- Accessories
- 5/94

Protection Equipment

Introduction

Overview



Type	3RV10	3RV11	3RV13	3RV14	3RV16	3RV16	3RV17	3RV18
3RV1 motor starter protectors/circuit breakers up to 100 A								
Applications								
System protection	✓ ¹⁾	✓ ¹⁾	--	--	--	--	✓	✓
Motor protection	✓	--	--	--	--	--	--	--
Motor protection with overload relay function	--	✓	--	--	--	--	--	--
Starter combinations	--	--	✓	--	--	--	--	--
Transformer protection	--	--	--	✓	--	--	✓	✓
Fuse monitoring	--	--	--	--	✓	--	--	--
Voltage transformer circuit breakers for distance protection	--	--	--	--	--	✓	--	--
Size	S00, S0, S2, S3	S0, S2, S3	S0, S2, S3	S0, S2	S00	S00	S0, S3	S0
Rated current I_n								
Size S00	A Up to 12	--	--	--	0.2	Up to 3	--	--
Size S0	A Up to 25	Up to 25	Up to 25	Up to 20	--	--	Up to 22	Up to 20
Size S2	A Up to 50	Up to 50	Up to 50	Up to 40	--	--	--	--
Size S3	A Up to 100	Up to 100	Up to 100	--	--	--	Up to 70	--
Rated operational voltage U_e acc. to IEC	V 690 AC ²⁾	690 AC ²⁾	690 AC ²⁾	690 AC ²⁾	690 AC ²⁾	400 AC	690 AC	690 AC
Rated frequency	Hz 50/60	50/60	50/60	50/60	50/60	16 ² / ₃ ... 60	50/60	50/60
Trip classes								
	CLASS 10 CLASS 20	CLASS 10	--	CLASS 10	--	--	--	--
Thermal overload releases								
A	0.11 ... 0.16 to	0.11 ... 0.16 to	None ³⁾	0.11 ... 0.16 to	0.2	1.4 ... 3	0.16 ... 70 non-adjustable	0.16 ... 20 non-adjustable
A	80 ... 100	80 ... 100		28 ... 40				
Electronic trip units								
A multiple of the rated current	13 times	13 times	13 times	20 times	6 times	4 ... 7 times	13 times	20 times
Short-circuit breaking capacity I_{cu} at 400 V AC								
kA	50/100	50/100	50/100	50/100	100	50	4) 4)	4) 4)

Accessories								
For sizes	S00 S0 S2 S3	S0 S2 S3	S0 S2 S3	S0 S2	S00	S00	S0, S3	S0
Auxiliary switches	✓ ✓ ✓ ✓	✓ ✓ ✓	✓ ✓ ✓	✓ ✓	✓	✓	✓ ⁵⁾	✓ ⁵⁾
Signal switches	-- ✓ ✓ ✓	✓ ✓ ✓	✓ ✓ ✓	✓ ✓	--	--	--	--
Undervoltage trip units	✓ ✓ ✓ ✓	-- -- --	✓ ✓ ✓	✓ ✓	✓	✓	✓	✓
Shunt trip units	✓ ✓ ✓ ✓	-- -- --	✓ ✓ ✓	✓ ✓	✓	✓	✓	✓
Isolator modules	-- ✓ ✓ --	✓ ✓ --	✓ ✓ --	✓ ✓	--	--	--	--
Insulated three-phase busbar system	✓ ✓ ✓ --	-- ✓ --	✓ ✓ --	✓ ✓	✓	✓	--	--
Busbar adapters	✓ ✓ ✓ ✓	✓ ✓ ✓	✓ ✓ ✓	✓ ✓	✓	✓	--	--
Door-coupling rotary operating mechanisms	-- ✓ ✓ ✓	✓ ✓ ✓	✓ ✓ ✓	✓ ✓	--	--	✓	✓
Remote motorized operating mechanisms	-- -- ✓ ✓	-- ✓ ✓	-- ✓ ✓	-- ✓	--	--	--	--
Link modules	✓ ✓ ✓ ✓	✓ ✓ ✓	✓ ✓ ✓	✓ ✓	✓	✓	--	--
Enclosures for surface mounting	✓ ✓ ✓ --	✓ ✓ --	✓ ✓ --	✓ ✓	✓	✓	--	--
Enclosures for flush mounting	✓ ✓ -- --	✓ -- --	✓ -- --	✓ --	✓	✓	--	--
Front plates	✓ ✓ ✓ ✓	✓ ✓ ✓	✓ ✓ ✓	✓ ✓	✓	✓	--	--
Infeed systems	✓ ✓ -- --	-- -- --	✓ -- --	✓ --	--	--	--	--

1) For symmetrical loading of the three phases.

2) 500 V AC with molded-plastic enclosure.

3) For overload protection of the motors, appropriate overload relays must be used.

4) According to UL 489
-at 480 Y/277 V AC: for size S0 50 kA, for size S3 65 kA;
-at 480 V AC: for size S3 (10 A up to 30 A) 65 kA.

5) Only lateral auxiliary switches can be fitted.

✓ Has this function or can use this accessory

-- Does not have this function or cannot use this accessory



Type	3RV10			3RV13					
3RV1 molded case motor starter protectors up to 800 A									
Applications									
Motor protection	✓			--					
Starter combinations	--			✓					
Switching capacity	Standard switching capacity			Standard switching capacity			Increased switching capacity		
Size	3RV10 63	3RV10 73	3RV10 83	3RV13 53	3RV13 63	3RV13 73	3RV13 83	3RV13 64	3RV13 74
Rated current I_n	A 100, 160, 200	400	630	1 ... 32	100, 160, 250	400, 630	630, 800	100, 160, 250	400
Rated operational voltage U_e acc. to IEC	V 690 AC			690 AC					
Rated frequency	Hz 50/60			50/60					
Trip classes	CLASS 10A CLASS 10 CLASS 20 CLASS 30			...1)					
Thermal overload releases	A 40 ... 100 to A 252 ... 630				None ¹⁾				
Electronic trip units A multiple of the rated current	Adjustable, 6 ... 13 times			Non-adjustable 1 A ... 12.5 A: 13 times; adjustable 20 A, 32 A: 6 ... 12 times	1 ... 10 times				
Short-circuit breaking capacity I_{cu} at 400 V AC	120	120	100	85	120	120	100	200	200
Trip units	TU 4			TU 1: 1 A ... 12.5 A; TU 2: 20 A, 32 A	TU 3				

Accessories									
For molded case motor starter protectors	3RV10 63	3RV10 73	3RV10 83	3RV13 53	3RV13 63	3RV13 73	3RV13 83	3RV13 64	3RV13 74
Auxiliary switches	✓	✓	✓	✓	✓	✓	✓	✓	✓
Undervoltage trip units	✓	✓	✓	✓	✓	✓	✓	✓	✓
Shunt trip units	✓	✓	✓	✓	✓	✓	✓	✓	✓
Rotary operating mechanisms	✓	✓	✓	✓	✓	✓	✓	✓	✓
Connection methods									
• Front-extended terminals	✓	✓	--	✓	✓	✓	--	✓	✓
• Front-accessible cable terminals	✓	✓	✓	✓	✓	✓	✓	✓	✓
• Rear-accessible terminals	✓	✓	✓	✓	✓	✓	✓	✓	✓

¹⁾ For overload protection of the motors, appropriate overload relays must be used; see Catalog LV 1 "Low-Voltage Controls", Chapter 5.

✓ Has this function or can use this accessory
-- Does not have this function or cannot use this accessory

Protection Equipment

Introduction



Type		3RU11	3RB20	3RB21	3RB22/3RB23
Overload relays up to 630 A					
Applications					
System protection		✓ ¹⁾	✓ ¹⁾	✓ ¹⁾	✓ ¹⁾
Motor protection		✓	✓	✓	✓
Alternating current, three-phase		✓	✓	✓	✓
Alternating current, single-phase		✓	--	--	✓
Direct current		✓	--	--	--
Size of contactor		S00, S0, S2, S3	S00 ... S12	S00 ... S12	S00 ... S12
Rated operational current I_e					
Size S00	A	Up to 12	Up to 12	Up to 12	} Up to 25
Size S0	A	Up to 25	Up to 25	Up to 25	
Size S2	A	Up to 50	Up to 50	Up to 50	} Up to 100
Size S3	A	Up to 100	Up to 100	Up to 100	
Size S6	A	--	Up to 200	Up to 200	Up to 200
Size S10/S12, Size 14 (3TF6)	A	--	Up to 630	Up to 630	
Rated operational voltage U_e	V	690/1000 AC ²⁾	690/1000 AC ³⁾	690/1000 AC ³⁾	690/1000 AC ⁴⁾
Rated frequency	Hz	50/60	50/60	50/60	50/60
Trip classes		CLASS 10	CLASS 10, CLASS 20	CLASS 5, 10, 20, 30 Adjustable	CLASS 5, 10, 20, 30 Adjustable
Thermal overload releases	A	0.11 ... 0.16 to 80 ... 100	--	--	--
Solid-state overload releases	A	--	0.1 ... 0.4 to 160 ... 630	0.1 ... 0.4 to 160 ... 630	0.3 ... 3 to 63 ... 630
Rating for induction motor at 400 V AC	kW	0.04 to 45	0.04 ... 0.09 Up to 90 ... 450	0.04 ... 0.09 to 90 ... 450	0.09 ... 1.1 to 37 ... 450
Accessories					
For sizes		S00 S0 S2 S3	S00 S0 S2 S3 S6 S10/ S12	S00 S0 S2 S3 S6 S10/ S12	S00 S0 S2 S3 S6 S10/ S12
Terminal brackets for stand-alone installation		✓ ✓ ✓ ✓	✓ ✓ 5) 5) 5) 5)	✓ ✓ 5) 5) 5) 5)	5) 5) 5) 5) 5) 5)
Mechanical RESET		✓ ✓ ✓ ✓	✓ ✓ ✓ ✓ ✓ ✓	✓ ✓ ✓ ✓ ✓ ✓	-- -- -- -- -- --
Cable releases for RESET		✓ ✓ ✓ ✓	✓ ✓ ✓ ✓ ✓ ✓	✓ ✓ ✓ ✓ ✓ ✓	-- -- -- -- -- --
Electrical remote RESET		✓ ✓ ✓ ✓	-- -- -- -- -- --	Integrated in the unit	Integrated in the unit
Terminal covers		-- -- ✓ ✓	-- -- -- ✓ ✓ ✓	-- -- -- ✓ ✓ ✓	-- -- -- ✓ ✓ ✓
Sealable covers for setting knobs		Integrated in the unit	✓ ✓ ✓ ✓ ✓ ✓	✓ ✓ ✓ ✓ ✓ ✓	✓ ✓ ✓ ✓ ✓ ✓

¹⁾ The units are responsible in the main circuit for overload protection of the assigned electrical loads (e. g. motors), feeder cable and other switching and protection devices in the respective load feeder.

²⁾ Size S3 up to 1000 V AC.

³⁾ Size S2 (only with straight-through transformer), S3, S6, S10, S12 up to 1000 V AC.

⁴⁾ With reference to the 3RB29 .6 current measuring modules.

⁵⁾ Stand-alone installation without accessories is possible.

✓ Has this function or can use this accessory

-- Does not have this function or cannot use this accessory

Overview

The following illustrations show our 3RV1 motor starter protectors with the accessories which can be mounted for the various sizes, [see also "Introduction" --> "Overview"](#).

S00 motor starter protectors with mountable accessories

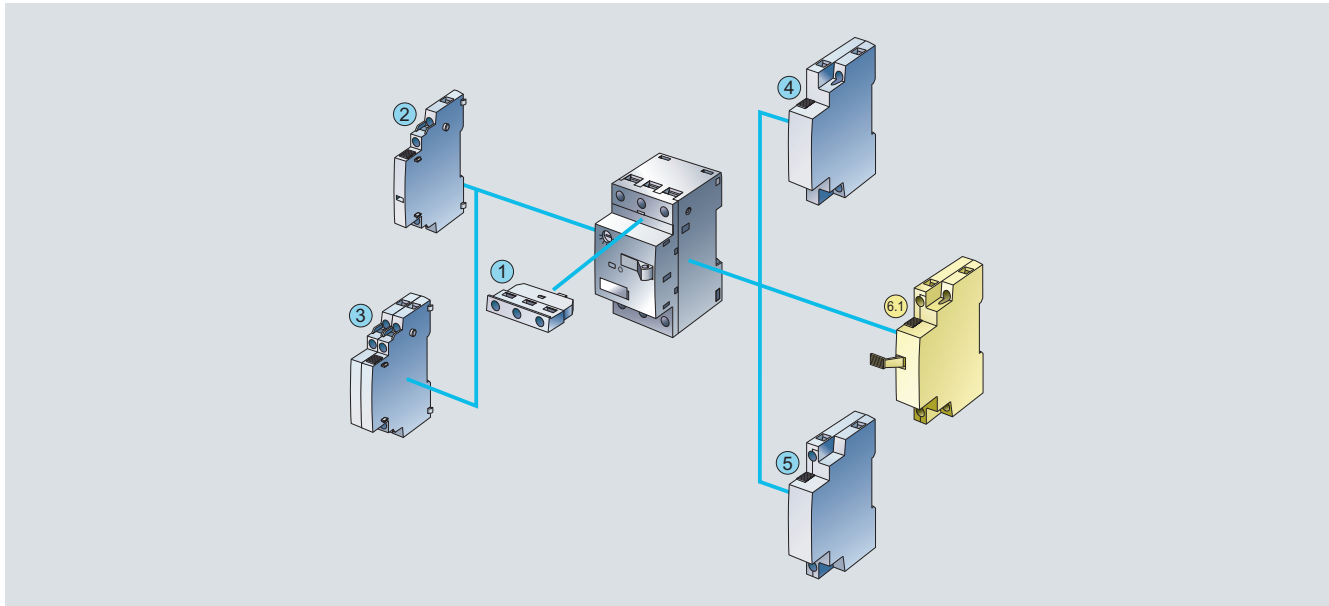

Motor starter protectors, sizes S0, S2 or S3, with mountable accessories

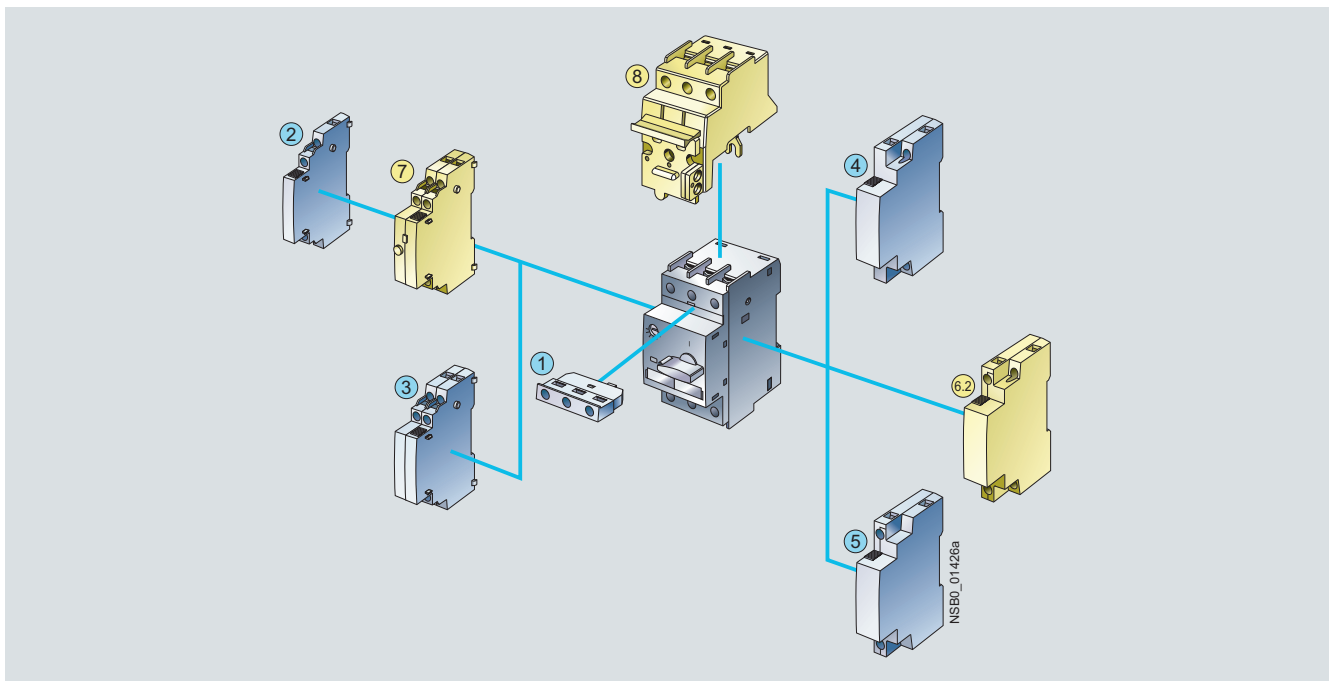

Mountable accessories for all sizes S00 ... S3

- ① Transverse auxiliary switch (can not be used with 3RV17 and 3RV18 circuit breakers)
- ② Lateral auxiliary switch with 2 contacts
- ③ Lateral auxiliary switch with 4 contacts
- ④ Shunt release
- ⑤ Undervoltage release

Mountable accessories

- ⑥.1 Undervoltage release with leading auxiliary contacts
- ⑥.2 Undervoltage release with leading auxiliary contacts
- ⑦ Alarm switch
- ⑧ Isolator module

for sizes

- S00
- S0 ... S3
- S0 ... S3
- S0 and S2

For accessories, see page 5/26.

3RV Motor Starter Protectors/Circuit Breakers up to 100 A

General data



Size S0 motor starter protector

3RV1 motor starter protectors are compact, current limiting motor starter protectors which are optimized for load feeders. The motor starter protectors are used for switching and protecting induction motors of up to 45 kW at 400 V AC and for other loads with rated currents of up to 100 A.

Type of construction

The motor starter protectors are available in four sizes:

- Size S00 - width 45 mm, max. rated current 12 A, at 400 V AC suitable for induction motors up to 5.5 kW.
- Size S0 – width 45 mm, max. rated current 25 A, at 400 V AC suitable for induction motors up to 11 kW.
- Size S2 – width 55 mm, max. rated current 50 A, at 400 V AC suitable for induction motors up to 22 kW.
- Size S3 – width 70 mm, max. rated current 100 A, at 400 V AC suitable for induction motors up to 45 kW.

Note

 Screw terminals

 Cage Clamp terminals

These connections are indicated in the Technical specifications by orange backgrounds.

"Increased safety" type of protection EEx e according to ATEX directive 94/9/EC

The 3RV10 motor starter protectors are suitable for the overload protection of explosion-proof motors with "increased safety" type of protection EEx e;

see Catalog LV 1, Chapter 20 "Appendix" --> "Standards and Approvals" --> "Type Overview of Approved Devices for Explosion-Protected Areas (ATEX Explosion Protection)".

Design

Screw terminals

3RV1 motor starter protectors of sizes S00 and S0 are fitted with terminals with captive screws and clamping pieces, allowing the connection of 2 conductors with different cross-sections.

The box terminals of the S2 and S3 motor starter protectors also enable 2 conductors with different cross-sections to be connected. With the exception of S3 motor starter protectors which

are equipped with 4 mm Allen screws, all terminal screws are tightened with a Pozidriv screwdriver size 2.

The box terminals of the S3 motor starter protectors can be removed in order to connect conductors with cable lugs or connecting bars. A terminal cover is available as touch protection and to ensure that the required clearances and creepage distances are maintained if the box terminals are removed.

Cage Clamp terminals

As an alternative to screw terminals, S00 motor starter protectors are also available with Cage Clamp terminals.

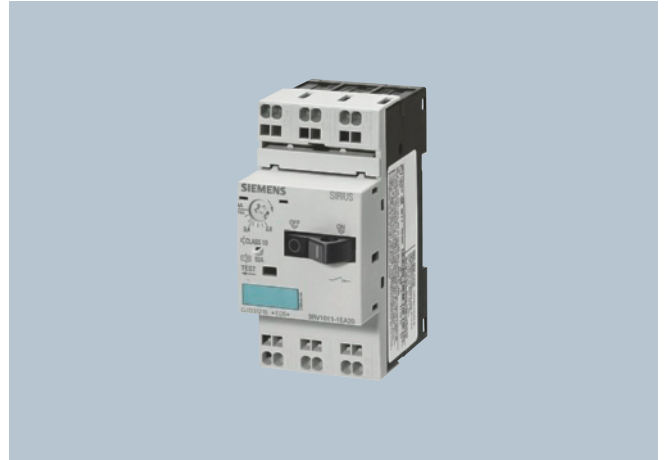

Motor starter protector size S00 with Cage Clamp terminals

This screwless connection method, already familiar from terminal blocks, clamps the conductors using a spring-type terminal and is shock-proof and vibration-proof.

Motor starter protectors with Cage Clamp terminals allow independent connection of two conductors per terminal.

Mounting

The motor starter protectors are snap-fitted on a 35 mm standard mounting rail to EN 60715.

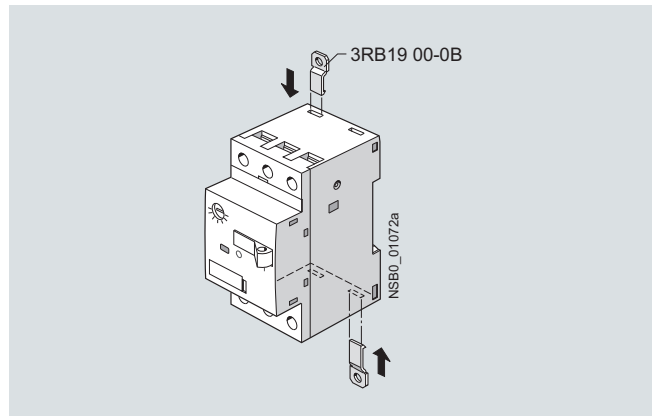

Push-in lugs for screwing the motor starter protector onto mounting plates.

A standard mounting rail with a height of 15 mm is required for size S3 motor starter protectors. A 75 mm standard mounting rail can be used as an alternative for size S3.

S2 and S3 motor starter protectors can also be screwed directly onto a base plate.

The 3RB19 00-0B push-in lugs are available for screw mounting of S00 and S0 motor starter protectors.

3RV Motor Starter Protectors/Circuit Breakers up to 100 A

General data

3RV16 voltage transformer circuit breakers up to 3 A

The voltage transformer circuit breaker widely corresponds with the SIRIUS 3RV1 motor starter protector, size S00. Two special features are taken into account for safe prevention of false tripping of the distance protection device.

Auxiliary switch for blocking the distance protection

The main contacts of the circuit breaker are opened if the voltage transformer circuit breaker is tripped or switched off. The distance protection would falsely interpret low impedance as a fault, which results in immediate power disconnection within only a few milliseconds.

To prevent this false tripping, special auxiliary contacts with a time-dependent assignment to the circuit breaker's main contacts (see timing diagram) must be provided. The distance protection is blocked with the help of these auxiliary contacts and thus prevents false tripping.

An auxiliary switch for blocking the distance protection device is available as 1 changeover contact fitted permanently in the

voltage transformer circuit breaker. This changeover contact can be used as 1 NO (11-14) or 1 NC (11-12). Thanks to the high contact stability of these auxiliary contacts at the lowest possible rated operational currents, they are also suitable for modern solid-state distance protection devices.

The laterally mounted auxiliary switches of the SIRIUS range can be used for signaling purposes. They cannot be used for blocking the distance protection device.

Impedance across the main contacts

There is only minor current flow across the main contacts of the voltage transformer circuit breaker.

To ensure reliable functioning of the distance protection, transfer resistance of the main contacts must be minimal and nearly constant throughout the endurance of the circuit breaker.

This is implemented with suitable contacts and contact materials for the 3RV16 voltage transformer circuit breaker.

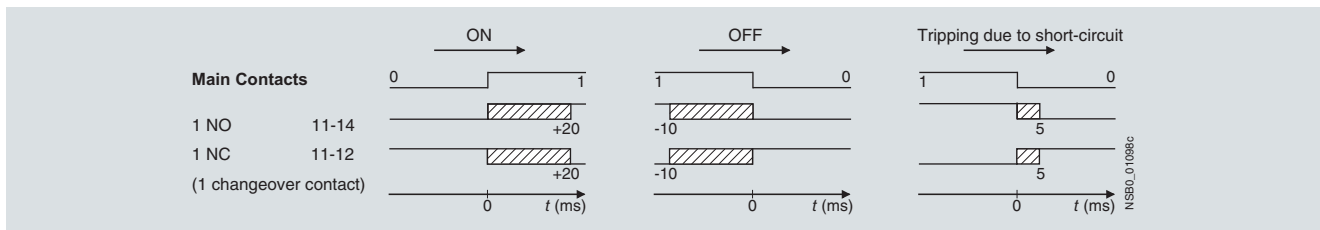

Timing diagram of auxiliary switches for blocking distance protection

Installation guidelines for motor starter protectors/circuit breakers

When mounting the motor starter protectors, the following clearances must be maintained to grounded or live parts and to cable ducts made of molded plastic.

Motor starter protectors/circuit breakers			Distance to grounded or live parts and to molded-plastic cable ducts acc. to IEC 60947-2		
Type	Size	U_e V	Y mm	X mm	Z mm
3RV1. 1, 3RV16 1.	S00	Up to 690	20	70	9
3RV1. 2, 3RV17 21, 3RV18 21	S0	Up to 500 Up to 690	30 50	90 90	9 30
3RV1. 3	S2	Up to 690	50	140	10
3RV1. 4	S3	Up to 240 Up to 440 Up to 500 Up to 690	50 70 110 150	167 167 167 167	-- -- 10 30
3RV17 42	S3	Up to 240 Up to 400	90 90	167 167	10 10

Installation guidelines for motor starter protectors/circuit breakers with limiter function

Motor starter protectors/circuit breakers			Distance to grounded or live parts and to molded-plastic cable ducts acc. to IEC 60947-2		
Type	Size	U_e V	Y mm	X mm	Z mm
3RV1. 2	S0	Up to 500 Up to 690	40 50	90 90	10 30
3RV1. 3	S2	Up to 690	50	140	10
3RV1. 4	S3	Up to 500 Up to 690	110 150	167 167	10 30

3RV Motor Starter Protectors/Circuit Breakers up to 100 A

General data

Standard mounting for S0, S2 and S3

Wiring module
 Size S0: 3RV19 15-1A
 Size S2: 3RV19 35-1A
 Size S3: 3RV19 43-3A
 (Caution: The wiring module demands 10 mm spacing between the motor starter protectors)

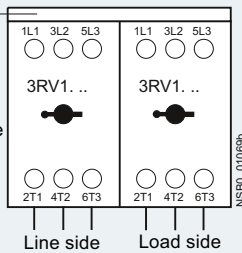

Structure for S0 for the setting ranges
 5.5 A ... 8 A up to 20 A ... 25 A for 690 V

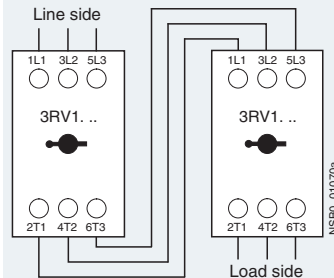

Function

Trip units

3RV1 motor starter protectors are equipped with inverse-time delayed overload release based on the bimetal principle and with instantaneous electronic trip units (electromagnetic short-circuit releases).

The overload releases can be adjusted in accordance with the load current. The electronic trip units are permanently set to a value 13 times the rated current and thus enable trouble-free starting of motors.

Motor starter protectors for line-side transformer protection are set to 20 times the rated current to prevent tripping as a result of high transformer inrush current.

The scale cover can be sealed to prevent unauthorized adjustments to the set current.

Trip classes

The trip classes of thermally delayed trip units are based on the tripping time (t_A) at 7.2 times the set current in cold state (excerpt from IEC 60947-4):

- CLASS 10A: $2 \text{ s} < t_A < 10 \text{ s}$
- CLASS 10: $4 \text{ s} < t_A < 10 \text{ s}$
- CLASS 20: $6 \text{ s} < t_A < 20 \text{ s}$
- CLASS 30: $9 \text{ s} < t_A < 30 \text{ s}$

The motor starter protector must trip within this time!

Operating mechanisms

S00 motor starter protectors are actuated by a rocker operating mechanism and S0, S2 and S3 motor starter protectors by a rotary operating mechanism. If the motor starter protector trips, the rotary operating mechanism switches to the tripped position to indicate this. Before the motor starter protector is reclosed, the rotary operating mechanism must be reset manually to the 0 position. Only then can the motor starter protector be set again to the I position.

In the case of motor starter protectors with rotary operating mechanisms, an electrical signal can be output by a signal switch to indicate that the motor starter protector has tripped.

All operating mechanisms can be locked in the 0 position with a padlock (shackle diameter 3.5 mm to 4.5 mm).

The motor starter protector isolating function complies with IEC 60947-2.

Configuration

Prevention of unintended tripping

In order to prevent premature tripping due to the integrated phase failure sensitivity, motor starter protectors should always be connected to ensure current flows through all three main current paths.

Short-circuit protection

If a short-circuit occurs, the short-circuit releases of 3RV1 motor starter protectors isolate the faulty load feeder from the network and thus prevent further damage.

Motor starter protectors with a short-circuit breaking capacity of 50 kA or 100 kA are virtually short-circuit resistant at a voltage of 400 V AC, since higher short-circuit currents are not to be expected in practice.

Motor protection

The tripping characteristics of 3RV10/3RV11 motor starter protectors are designed mainly to protect induction motors.

The motor starter protectors are therefore also referred to as motor-protective circuit breakers.

The rated current I_n of the motor to be protected is set on the setting scale. Factory setting of the short-circuit release is 13 times the rated current of the motor starter protector. This permits trouble-free starting and ensures that the motor is properly protected.

The phase failure sensitivity of the motor starter protector ensures that it is tripped in time in the event of a phase failure and overcurrents that occur as a result in the other phases.

Motor starter protectors with thermal overload releases are normally designed in accordance with trip class 10 (CLASS 10). Motor starter protectors of sizes S2 and S3 are also available in trip class 20 (CLASS 20) and therefore allow motors to be started up under arduous conditions.

Motor protection with overload relay function (automatic RESET)

The 3RV11 motor starter protectors for motor protection with overload relay function are designed for the protection of induction motors.

They are equipped with the same short-circuit release and overload release as motor starter protectors for motor protection without overload relay function.

The motor starter protector always remains closed in the event of an overload. The overload release activates only two auxiliary contacts (1 NO + 1 NC). The overload trip can be signaled to a higher-level control with the help of these auxiliary contacts. Generally, it is also possible to open a downstream contactor directly.

The overload signal is reset automatically. The motor starter protector itself only trips if a short-circuit occurs downstream.

3RV Motor Starter Protectors/Circuit Breakers up to 100 A

General data

System protection

The 3RV10 and 3RV11 motor starter protectors for motor protection are also suitable for plant protection.

In order to prevent premature tripping due to phase failure sensitivity, the three conducting paths must always be uniformly loaded. The conducting paths must be connected in series in the case of single-phase loads.

The 3RV17 and 3RV18 circuit breakers are suitable for system protection and at the same time they are approved as circuit breakers according to UL 489 and CSA C22.2 No. 5-02 for 100 % rated current (100 % rated breaker).

Short-circuit protection for starter combinations

The 3RV13 motor starter protectors for starter combinations in sizes S0, S2 and S3 provide short-circuit protection with the help of a contactor and overload relay combination.

Like the motor starter protectors for motor protection, they are equipped with short-circuit releases which are permanently set to a value equivalent to 13 times the rated current of the motor starter protectors. They are not equipped with overload releases.

On overload, the overload relay triggers the contactor, the motor starter protector remains closed.

Only when a short-circuit occurs in the feeder does the motor starter protector trip as well.

The motor starter protector for starter combinations must always be used in combination with an overload relay because the motor starter protector alone cannot protect the motor and itself against overload.

Transformer protection

When control transformers are protected on the line side, the high inrush currents generated at the time the transformers are switched on often cause spurious tripping in the protection mechanisms.

3RV14 motor starter protectors in sizes S0 and S2 and 3RV18 circuit breakers in size S0 for protecting transformers are therefore fitted with electronic trip units which are permanently set in the factory to a value equivalent to 20 times the rated current. For the 3RV17 circuit breakers in sizes S0 and S3 these electronic trip units are set in the factory to approximately 13 times the rated current.

Motor starter protectors can thus be used to provide line-side protection for transformers, the inrush peak currents of which are up to 30 times the rated current.

The 3RV17 and 3RV18 are approved as circuit breakers according to UL 489 and CSA 22.2 No. 5-02 for the protection of transformers, the 3RV18 circuit breakers size S0 are designed specially for the protection of transformers with high inrush current.

This version of motor starter protector is not necessary in the case of control-power transformers with low inrush currents, such as control transformers from Siemens. 3RV1 motor starter protectors for motor protection can be used in this case.

Main and EMERGENCY-STOP switches

The 3RV10, 3RV11, 3RV13, 3RV14 and 3RV16 motor starter protectors comply with the isolating function to IEC 60947-2, therefore they can be used – taking IEC 60204-1 into account – as main and EMERGENCY-STOP switches.

3RV19 .6-2. door-coupling rotary operating mechanisms for heavy duty also comply with the requirements for the isolating function.

Fuse monitoring

The 3RV16 11-0BD10 motor starter protector size S00 is used for fuse monitoring.

A fuse is connected in parallel with each conducting path of the motor starter protector. When a fuse blows, the current flows through the parallel conducting path and trips the motor starter protector.

The 3RV16 11-0BD10 motor starter protector for fuse monitoring must be equipped with a transverse or lateral auxiliary switch (see "Accessories") that signals a tripping operation of the motor starter protector and thus the tripping of the fuse, or switches off all poles of the disrupted electric circuit with the help of an appropriate switching device.



Motor starter protector for fuse monitoring

Notes on safety

When monitoring fuses with safety isolating functions, a warning sign must be affixed near the fuses indicating that voltage may still be present through the parallel circuit of the monitoring equipment assumed to be isolated after the fuse has been removed and if the monitoring equipment is not switched off.

We recommend the following text for this warning:

Caution!

For safety isolation, also switch off fuse monitoring equipment with the item code

The 3RV16 11-0BD10 motor starter protector for fuse monitoring is suitable for the following voltages: AC 50 Hz/60 Hz from 24 V to 690 V and up to 450 V DC. Fuse monitoring with 3RV16 11-0BD10 motor starter protector is not permissible in feeders with power controllers that can induce DC feedback of higher values when an error occurs.

With parallel cables and meshed systems, the motor starter protector will only trip, and a signal will be output to indicate this, if the voltage difference across the motor starter protector is at least 24 V.

Use of IT systems (IT networks)

3RV1 motor starter protectors are suitable for operation in IT systems according to IEC 60947-2. In the event of a three-pole short-circuit, their response in this system is the same as in others: Therefore, the same short-circuit breaking capacity I_{cu} and I_{cs} applies, (see "Technical specifications").

An initial fault (ground fault) does not necessarily force immediate disconnection of the network when operating IT systems. If a second independent error occurs (ground fault), the switching capacity of the motor starter protector might be reduced.

This is the case if both ground faults occur in different phases and if one of the ground faults occurs on the input side and the other on the outgoing terminal of the motor starter protector.

In order to maintain the short-circuit function of the motor starter protector even with two independent ground faults (double ground faults), the reduced short-circuit breaking capacity with double ground faults must be taken into account in IT systems I_{cuIT} (see "Technical specifications"). If a ground fault is instantaneously recognized and remedied (ground-fault monitoring), the risk of double ground fault and thus reduced short-circuit breaking capacity I_{cuIT} can be minimized.

3RV Motor Starter Protectors/Circuit Breakers up to 100 A

General data

Switching of direct current

3RV1 motor starter protectors for alternating currents are also suitable for DC switching.

The maximum permissible DC voltage per conducting path must, however, be adhered to. Higher voltages require a series connection with 2 or 3 conducting paths.

The response values of the overload release remain unchanged; the response values of a short-circuit release increase by approximately 30 % for DC. The example circuits for DC switching can be seen in the table below.

Example circuit for size S00 to S3 3RV1 motor starter protectors

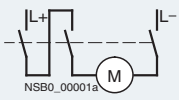
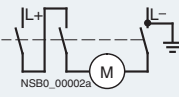
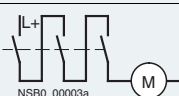
Example circuit for size S00 to S3 3RV1 motor starter protectors	Maximum permitted DC voltage U_e	Notes
 NSB0_00001a	150 V DC	<u>Three-pole switching, non-grounded system¹⁾</u> If there is no possibility of a ground fault, or if every ground fault is rectified immediately (ground-fault monitoring), then the maximum permitted DC voltage can be tripled.
 NSB0_00002a	300 V DC	<u>Two-pole switching, grounded system</u> The grounded pole is always assigned to the individual conducting path, so that there are always 2 conducting paths in series in the event of a ground fault.
 NSB0_00003a	450 V DC	<u>Single-pole switching, grounded system</u> 3 conducting paths in series. The grounded pole is assigned to the unconnected conducting path.

¹⁾ It is assumed that this circuit always provides safe disconnection even in the event of a double ground fault that bridges two contacts.

3RV16 voltage transformer circuit breakers up to 3 A

The voltage transformer circuit breaker protects the secondary side of voltage transformers used to connect protection equipment with voltage-dependent starting. The circuit breaker is used for distance protection with low-impedance starting. Special auxiliary contacts reliably prevent low-impedance starting from triggering distance protection if only one fault has occurred in the transformer line.

The voltage transformer circuit breaker can also be used to safely disconnect the distance protection device from the voltage transformer. In this case, the special auxiliary contacts also prevent false tripping of the distance protection.

Additional fuses are not required. A "Fuse Failure Monitor" (FFM) is also not required.

3RV Motor Starter Protectors/Circuit Breakers up to 100 A

General data

Technical specifications

Short-circuit breaking capacity I_{cu} , I_{cs} acc. to IEC 60947-2

This table shows the rated ultimate short-circuit breaking capacity I_{cu} and the rated service short-circuit breaking capacity I_{cs} of the 3RV1 motor starter protectors with different inception voltages dependent of the rated current I_n of the motor starter protectors.





Motor starter protector infeed is permissible at the upper or lower terminals without restricting the rated data. If the short-circuit current at the place of installation exceeds the rated short-circuit breaking capacity of the motor starter protector as specified in the table, a back-up fuse is required. Alternatively, a

motor starter protector with a limiter function can be connected upstream.

The maximum rated current for the back-up fuse is specified in the tables. The rated ultimate short-circuit breaking capacity then applies as specified on the fuse.

Fuseless construction

Motor starter protector contactor combinations for short-circuit currents up to 50 kA can be ordered in the form of fuseless load feeders according to Chapter 6.

Motor starter protectors/circuit breakers	Rated current I_n	Up to 240 V AC ¹⁾			Up to 400 V ¹⁾ /415 V AC ²⁾			Up to 440 V ¹⁾ /460 V AC ²⁾			Up to 500 V ¹⁾ /525 V AC ²⁾			Up to 690 V AC ¹⁾		
		I_{cu}	I_{cs}	Max. fuse (gL/gG) 	I_{cu}	I_{cs}	Max. fuse (gL/gG) ³⁾ 	I_{cu}	I_{cs}	Max. fuse (gL/gG) ³⁾ 	I_{cu}	I_{cs}	Max. fuse (gL/gG) ³⁾ 	I_{cu}	I_{cs}	Max. fuse (gL/gG) ³⁾⁴⁾ 
Type	A	kA	kA	A	kA	kA	A	kA	kA	A	kA	kA	A	kA	kA	A
Size S00																
3RV10, 3RV16 11-0BD10	0.16 ... 1	100	100	°	100	100	°	100	100	°	100	100	°	100	100	°
	1.25; 1.6	100	100	°	100	100	°	100	100	°	100	100	°	2	2	20
	2; 2.5	100	100	°	100	100	°	100	100	°	10	10	35	2	2	35
	3.2; 4	100	100	°	100	100	°	50	10	40	3	3	40	2	2	40
	5; 6.3	100	100	°	100	100	°	50	10	50	3	3	50	2	2	50
	8	100	100	°	50	12.5	80	50	10	63	3	3	63	2	2	63
	10	100	100	°	50	12.5	80	10	10	63	3	3	63	2	2	63
	12	100	100	°	50	12.5	80	10	10	80	3	3	80	2	2	80
Size S0																
3RV1. 2, 3RV17 21, 3RV18 21	0.16 ... 1.6	100	100	°	100	100	°	100	100	°	100	100	°	100	100	°
	2; 2.5	100	100	°	100	100	°	100	100	°	100	100	°	8	8	25
	3.2	100	100	°	100	100	°	100	100	°	100	100	°	8	8	32
	4; 5	100	100	°	100	100	°	100	100	°	100	100	°	6	3	32
	6.3	100	100	°	100	100	°	100	100	°	100	100	°	6	3	50
	8	100	100	°	100	100	°	50	25	63	42	21	63	6	3	50
	10	100	100	°	100	100	°	50	25	80	42	21	63	6	3	50
	12.5	100	100	°	100	100	°	50	25	80	42	21	80	6	3	63
	16	100	100	°	50	25	100	50	10	80	10	5	80	4	2	63
	20	100	100	°	50	25	125	50	10	80	10	5	80	4	2	63
	22; 25	100	100	°	50	25	125	50	10	100	10	5	80	4	2	63
Size S2																
3RV1. 3	16	100	100	°	50	25	100	50	25	100	12	6	63	5	3	63
	20	100	100	°	50	25	100	50	25	100	12	6	80	5	3	63
	25	100	100	°	50	25	100	50	15	100	12	6	80	5	3	63
	32	100	100	°	50	25	125	50	15	125	10	5	100	4	2	63
	40; 45	100	100	°	50	25	160	50	15	125	10	5	100	4	2	63
	50	100	100	°	50	25	160	50	15	125	10	5	100	4	2	80
Size S3																
3RV1. 41	40	100	100	°	50	25	125	50	20	125	12	6	100	6	3	63
	50	100	100	°	50	25	125	50	20	125	12	6	100	6	3	80
	63	100	100	°	50	25	160	50	20	160	12	6	100	6	3	80
	75	100	100	°	50	25	160	50	20	160	8	4	125	5	3	100
	90; 100	100	100	°	50	25	160	50	20	160	8	4	125	5	3	125
Size S3, with increased switching capacity																
3RV1. 42 / 3RV17 42 ⁵⁾	16/10	100	100	°	100	50	°	100	50	°	30	15	80	12	7	63
	20/15	100	100	°	100	50	°	100	50	°	30	15	80	12	7	63
	25/20	100	100	°	100	50	°	100	50	°	30	15	80	12	7	63
	32/25	100	100	°	100	50	°	100	50	°	22	11	100	12	7	63
	40/30	100	100	°	100	50	°	100	50	°	18	9	160	12	6	80
	50/35 ... 40	100	100	°	100	50	°	100	50	°	15	7.5	160	10	5	100
	63/45 ... 50	100	100	°	100	50	°	70	50	200	15	7.5	160	7.5	4	100
	75/60	100	100	°	100	50	°	70	50	200	10	5	160	6	3	125
	90/70	100	100	°	100	50	°	70	50	200	10	5	160	6	3	160
	100/--	100	100	°	100	50	°	70	50	200	10	5	160	6	3	160

Short-circuit resistant up to at least 50 kA

° No back-up fuse required, since short-circuit resistant up to 100 kA

1) 10 % overvoltage.

2) 5 % overvoltage.

3) Back-up fuse only required if the short-circuit current at the place of installation $> I_{cu}$.

4) Alternatively, fuseless limiter combinations for 690 V AC can also be used.

5) The values for the 3RV17 42 circuit breakers have been tested only up to 400 V/415 V AC; values > 440 V AC on request.

3RV Motor Starter Protectors/Circuit Breakers up to 100 A

General data

Short-circuit breaking capacity I_{cuIT} in the IT system (IT network) according to IEC 60947-2

3RV1 motor starter protectors are suitable for operation in IT systems. Values valid for triple-pole short-circuit are I_{cu} up to I_{CS} . In case of double ground fault on different phases at the input and output side of a motor starter protector, the special short-circuit breaking capacity I_{cuIT} applies. The specifications in the table below apply to 3RV1 motor starter protectors.

In the colored areas, I_{cuIT} is 100 kA, or in some ranges it is 50 kA. Therefore the motor starter protectors are short-circuit resistant in these ranges.

If the short-circuit current at the place of installation exceeds the rated short-circuit breaking capacity of the motor starter protector as specified in the table, a back-up fuse is required. The maximum rated current for the back-up fuse is specified in the tables. The rated short-circuit breaking capacity then applies as specified on the fuse.

Motor starter protectors	Rated current I_n	Up to 240 V AC ¹⁾		Up to 400 V ¹⁾ /415 V AC ²⁾		Up to 500 V ¹⁾ /525 V AC ²⁾		Up to 690 V AC ¹⁾	
		I_{cuIT}	Max. fuse (gL/gG) ³⁾	I_{cuIT}	Max. fuse (gL/gG) ³⁾⁴⁾	I_{cuIT}	Max. fuse (gL/gG) ³⁾	I_{cuIT}	Max. fuse (gL/gG) ³⁾
Type	A	kA	A	kA	A	kA	A	kA	A
Size S00									
3RV10, 3RV16 11-0BD10	0.16 ... 0.63	100	°	100	°	On request	On request	On request	On request
	0.8; 1	100	°	100	°				
	1.25; 1.6	100	°	2	20				
	2; 2.5	100	°	2	35				
	3.2; 4	100	°	2	40				
	5; 6.3	100	°	2	50				
	8; 10	50	80	2	63				
12	50	80	2	80					
Size S0									
3RV1. 2	0.16 ... 0.63	100	°	100	°	On request	On request	On request	On request
	0.8; 1	100	°	100	°				
	1.25; 1.6	100	°	100	°				
	2; 2.5	100	°	8	25				
	3.2	100	°	8	32				
	4; 5	100	°	6	32				
	6.3 ... 10	100	°	6	50				
	12.5	100	°	6	63				
16 ... 25	50	80	4	63					
Size S2									
3RV1. 3	16	50	100	8	100	6	80	5	63
	20	50	125	8	100	6	80	5	63
	25	50	125	8	100	6	80	5	63
	32	50	125	6	125	4	100	3	80
	40 ... 50	50	160	6	125	4	100	3	80
Size S3									
3RV1. 41	40	50	125	10	63	5	50	5	50
	50	50	125	8	80	3	63	3	63
	63	50	160	6	80	3	63	3	63
	75	50	160	5	100	2	80	2	80
	90; 100	50	160	5	125	2	100	2	100
Size S3, with increased switching capacity									
3RV1. 42	16	100	°	12	63	6	50	6	50
	20	100	°	12	63	6	50	6	50
	25	100	°	12	63	6	50	6	50
	32	100	°	12	63	6	50	6	50
	40	100	°	12	80	6	63	6	63
	50	100	°	10	100	4	80	4	80
	63	100	°	7.5	100	4	80	4	80
	75	100	°	6	125	3	100	3	100
	90	100	°	6	160	3	125	3	125
	100	100	°	6	160	3	125	3	125

Short-circuit resistant up to at least 50 kA

° No back-up fuse required, since short-circuit resistant up to 100 kA

1) 10 % overvoltage.

2) 5 % overvoltage.

3) Back-up fuse only required, if short-circuit current at the place of installation $> I_{cuIT}$.

4) Alternatively, fuseless limiter combinations for 690 V AC can also be used.

3RV Motor Starter Protectors/Circuit Breakers up to 100 A

General data

Limiter function with standard devices for 500 V AC and 690 V AC acc. to IEC 60947-2

The table shows the rated ultimate short-circuit breaking capacity I_{cu} and the rated service short-circuit breaking capacity I_{cs} with an upstream standard motor starter protector that fulfills the limiter function at 500 V AC and 690 V AC. The short-circuit breaking capacity can be increased significantly with an upstream standard motor starter protector.

The motor starter protector which is connected downstream must be set to the rated current of the load.

With motor starter protector combination assemblies, note the clearance to grounded parts and between the motor starter protectors. Short-circuit resistant wiring between the motor starter protectors must be ensured. The motor starter protectors can be mounted side by side in a modular arrangement.

Standard motor starter protectors		Rated current I_n A	Up to 500 V ¹⁾ /525 V AC ²⁾		Up to 690 V AC ¹⁾	
Type	With limiter function rated current I_n Type		I_{cu} kA	I_{cs} kA	I_{cu} kA	I_{cs} kA
Size S0						
3RV10 2	3RV13 21-4DC10 $I_n = 25$ A	Up to 1 1.25 1.6 2 2.5 3.2 4 5 6.3 8 10 12.5 16 20 22 25	° ° ° ° ° ° ° ° ° 100 100 100 100 100 100 100 100	° ° ° ° ° ° ° ° ° 50 50 50 50 50 50 50 50	° ° ° ° ° ° ° ° ° 50 20 20 20 20 20 20 20	° ° ° ° ° ° ° ° ° 25 25 25 25 25 25 25 25
Size S2						
3RV10 3	3RV13 31-4HC10 $I_n = 50$ A	16 20 25 32 40 50	100 100 100 100 100 100	50 50 50 50 50 50	50 50 50 50 50 50	25 25 25 25 25 25
Size S3						
3RV10 4	3RV13 41-4HC10 $I_n = 50$ A	32 40 50	100 100 100	50 50 50	50 50 50	25 25 25
	3RV13 41-4MC10 $I_n = 100$ A	50 63 75 90 100	100 100 100 100 100	50 50 50 50 50	50 50 50 50 50	25 25 25 25 25

° Short-circuit resistant up to 100 kA

° No back-up fuse required, since short-circuit resistant up to 100 kA

1) 10 % overvoltage.

2) 5 % overvoltage.

3RV Motor Starter Protectors/Circuit Breakers up to 100 A

General data

General technical specifications		3RV1. 1 ¹⁾	3RV1. 2	3RV1. 3	3RV1. 4	3RV17 21	3RV17 42	3RV18 21
Type								
Standards		Yes				No		
• IEC 60947-1, EN 60947-1 (VDE 0660 Part 100)		Yes				Yes		
• IEC 60947-2, EN 60947-2 (VDE 0660 Part 101)		Yes				Yes		
• IEC 60947-4-1, EN 60947-4-1 (VDE 0660 Part 102)		No				No		
• UL 489, CSA C22.2-No.5-02		No				Yes		
Size		S00	S0	S2	S3	S0	S3	S0
Number of poles		3						
Max. rated current I_n max (= max. rated operational current I_e)	A	12	25	50	100	22	70	20
Permissible ambient temperature								
• Storage/transport	°C	-50 ... +80						
• Operation	°C	-20 ... +70 ²⁾						
Permissible rated current at inside temperature of control cabinet								
• +60 °C	%	100						
• +70 °C	%	87						
Motor starter protectors/circuit breakers inside enclosure								
Permissible rated current at ambient temperature of enclosure								
• +35 °C	%	100						
• +60 °C	%	87						
Rated operational voltage U_e								
• Acc. to IEC	V AC	690 ³⁾						
• Acc. to UL/CSA	V AC	600						
Rated frequency	Hz	50/60						
Rated insulation voltage U_i	V	690						
Rated impulse withstand voltage U_{imp}	kV	6						
Utilization categories								
• IEC 60947-2 (motor starter protector/circuit breaker)		A						
• IEC 60947-4-1 (motor starter)		AC -3						
Trip classes CLASS	Acc. to IEC 60947-4-1	10	10/20			--		
DC short-circuit breaking capacity (time constant $t = 5$ ms)								
• 1 conducting path 150 V DC	kA	10						
• 2 conducting paths in series 300 V DC	kA	10						
• 3 conducting paths in series 450 V DC	kA	10						
Power loss P_v per motor starter protector/circuit breaker								
Dependent on rated current I_n (upper setting range)								
$P_{v \text{ per conducting path}} = P/I^2 \times 3$								
I_n : ... 1.25 A	W	5	--					
I_n : 1.6 ... 6.3 A	W	6	--					
I_n : 8 ... 12 A	W	7	--					
I_n : ... 0.63 A	W	--	5	--	--	5	--	5
I_n : 0.8 ... 6.3 A	W	--	6	--	--	6	--	6
I_n : 8 ... 16 A	W	--	7	--	--	7	--	7
I_n : 20 ... 25 A	W	--	8	--	--	8	--	8
I_n : ... 25 A	W	--	--	12	--	--	--	--
I_n : 32 A	W	--	--	15	--	--	--	--
I_n : 40 ... 50 A	W	--	--	20	--	--	--	--
I_n : ... 63 A	W	--	--	--	20	--	--	--
I_n : 75 and 90 A	W	--	--	--	30	--	--	--
I_n : ... 100 A	W	--	--	--	38	--	--	--
I_n : ... 10 A	W	--	--	--	--	--	8	--
I_n : ... 35 A	W	--	--	--	--	--	12	--
I_n : ... 70 A	W	--	--	--	--	--	21	--
Shock resistance	Acc. to IEC 60068-2-27	g/ms	25/11 (square and sine pulse)					
Degree of protection	Acc. to IEC 60529		IP20 ⁴⁾					
Touch protection	Acc. to EN 50274		Finger-safe					
Temperature compensation	Acc. to IEC 60947-4-1	°C	-20 ... +60					
Phase failure sensitivity	Acc. to IEC 60947-4-1		Yes					
Explosion protection – safe operation of motors with "increased safety" type of protection			Yes, for 3RV10 (CLASS 10)					
EC type test certificate number acc. to directive 94/9/EC (ATEX)			No					
			DMT 02 ATEX F 001 II (2) GD, DMT 02 ATEX F 001 N1 II (2) GD					
Isolating function	Acc. to IEC 60947-2		Yes					
Main and EMERGENCY-STOP switch characteristics⁵⁾	Acc. to IEC 60204-1 (VDE 0113)		Yes					
Protective separation between main and auxiliary circuits, required for PELV applications	Acc. to EN 60947-1							
• Up to 400 V + 10 %			Yes					
• Up to 415 V + 5 % (higher voltages on request)			Yes					
Permissible mounting positions		Any, acc. to IEC 60447 start command "I" right-hand side or top						
Mechanical endurance	Operating cycles	100 000	50 000			100 000	50 000	100 000
Electrical endurance	Operating cycles	100 000	25 000			100 000	25 000	100 000
Max. switching frequency per hour (motor starts)	1/h	15						



For footnotes see page 5/15.

For short-circuit breaking capacity I_{cu} , I_{cs} see table of same name.

3RV Motor Starter Protectors/Circuit Breakers up to 100 A

General data

Conductor cross-sections of main circuit

Type		3RV1.	3RV1. 2	3RV1. 3	3RV1. 4/ 3RV17 42	3RV17 21, 3RV18 21
Connection type		 Screw terminals		 Screw terminals with box terminal		
Terminal screw		Pozi driv size 2		Pozi driv size 2	4 mm Allen screw	Pozi driv size 2
Prescribed tightening torque	Nm	0.8 ... 1.2	2 ... 2.5	3 ... 4.5	4 ... 6	2.5 ... 3
Conductor cross-sections (1 or 2 conductors connectable)						
• Solid	mm ²	2 x (0.5 ... 1.5) ⁴⁾ 2 x (0.75 ... 2.5) ⁴⁾	2 x (1 ... 2.5) ⁴⁾ 2 x (2.5 ... 6) ⁴⁾	2 x (0.75 ... 16)	2 x (2.5 ... 16)	1 ... 10, max. 2 x 10
• Finely stranded with end sleeve	mm ²	2 x (0.5 ... 1.5) ⁴⁾ 2 x (0.75 ... 2.5) ⁴⁾	2 x (1 ... 2.5) ⁴⁾ 2 x (2.5 ... 6) ⁴⁾	2 x (0.75 ... 16), 1 x (0.75 ... 25)	2 x (2.5 ... 35), 1 x (2.5 ... 50)	1 ... 16, max. 6 + 16
• Stranded	mm ²	2 x (0.5 ... 1.5) ⁴⁾ 2 x (0.75 ... 2.5) ⁴⁾	2 x (1 ... 2.5) ⁴⁾ 2 x (2.5 ... 6) ⁴⁾	2 x (0.75 ... 25), 1 x (0.75 ... 35)	2 x (10 ... 50), 1 x (10 ... 70)	1.5 ... 25, max. 10 + 25
• AWG cables, solid or stranded	AWG	2 x (18 ... 14)	2 x (14 ... 10)	2 x (18 ... 2), 1 x (18 ... 2)	2 x (10 ... 1/0), 1 x (10 ... 2/0)	2 x (14 ... 10)
Ribbon cable conductors (number x width x thickness) mm	--			2 x (6 x 9 x 0.8)		
Removable box terminals¹⁾						
• With copper bars ²⁾	--	--	--		18 x 10	--
• With cable lugs ³⁾	--	--	--		Up to 2 x 70	--
Connection type		 Cage Clamp terminals⁵⁾⁶⁾				
Conductor cross-sections (1 or 2 conductors connectable)						
• Solid	mm ²	2 x (0.25 ... 2.5)	--			
• Finely stranded with end sleeve	mm ²	2 x (0.25 ... 1.5)	--			
• Finely stranded without end sleeve	mm ²	2 x (0.25 ... 2.5)	--			
• AWG cables, solid or stranded	AWG	2 x (24 ... 14)	--			
Max. external diameter of the conductor insulation	mm	3.6				

Footnotes for page 5/14:

- 1) For 3RV16 voltage transformer circuit breakers see more "Technical specifications".
- 2) Above +60 °C current reduction.
- 3) 500 V with molded-plastic enclosure.
- 4) Terminal compartment IP00 (exception: 3RV10 11-..2. motor starter protectors with Cage Clamp terminals degree of protection IP20).
- 5) With appropriate accessories.

Footnotes for page 5/15:

- 1) Cable lug and busbar connection possible after removing the box terminals.
- 2) If bars larger than 12 mm x 10 mm are connected, a 3RT19 46-4EA1 terminal cover is needed to comply with the phase clearance.
- 3) If conductors larger than 25 mm² are connected, a 3RT19 46-4EA1 terminal cover is needed to comply with the phase clearance.
- 4) If two different conductor cross-sections are connected to one clamping point, both cross-sections must lie in the range specified. If identical cross-sections are used, this restriction does not apply.
- 5) For corresponding 8WA2 803 or 8WA2 880 opening tools see Catalog LV 1, Chapter 5 "Protection Equipment" --> "3RV Motor Starter Protectors up to 100 A" --> "Accessories".
- 6) With conductor cross-sections of ≤ 1 mm² an "insulation stop" must be used (see Chapter 3 "Contactors and Contactor Assemblies" --> "Accessories").

3RV Motor Starter Protectors/Circuit Breakers up to 100 A

General data

Permissible rated data of devices approved for North America (UL/CSA)

Motor starter protectors of the 3RV1 series are approved for UL/CSA and according to UL 508 and CSA C22.2 No. 14 they can be used on their own or as a load feeder in combination with a contactor.

These motor starter protectors can be used as "Manual Motor Controllers" for "Group Installations", as "Manual Motor Controllers Suitable for Tap Conductor Protection in Group Installations" and as "Self-Protected Combination Motor Controllers" (Type E).

3RV1 motor starter protectors as "Manual Motor Controllers"

If used as a "Manual Motor Controller", the motor starter protector is always operated in combination with an upstream short-circuit protection device. Approved fuses or a circuit breaker according to UL 489/CSA C22.2 No. 5-02 can be used. These devices must be dimensioned according to the National Electrical Code (UL) or Canadian Electrical Code (CSA).

Approval of the 3RV as a Manual Motor Controller can be found under the following file numbers:

- UL File No. 47705, CCN: NLRV,
- CSA Master Contract 165071, Product Class: 3211 05.

Motor starter protectors	hp rating ¹⁾ for FLA ²⁾ max.		Rated current I_n	240 V AC		480 V AC		600 V AC	
	1-phase	3-phase		UL $I_{bc}^{(3)}$	CSA $I_{bc}^{(3)}$	UL $I_{bc}^{(3)}$	CSA $I_{bc}^{(3)}$	UL $I_{bc}^{(3)}$	CSA $I_{bc}^{(3)}$
Type	V		A	kA	kA	kA	kA	kA	kA
Size S00									
3RV10 11, 3RV16 11-0BD10			0.16 ... 2	65	65	65	65	10	10
FLA ²⁾ max. 12 A, 600 V	115	1/2	--	2.5	65	65	65	10	10
NEMA size 00	200	1 1/2	3	3.2	65	65	65	10	10
	230	2	3	4	65	65	65	10	10
	460	--	7 1/2	5	65	65	65	10	10
	575/600	--	10	6.3	65	65	65	10	10
				8	65	65	65	10	10
				10	65	65	65	10	10
				12	65	65	65	10	10
Size S0									
3RV10 21/3RV11 21, 3RV13 21			0.16 ... 3.2	65	65	65	65	30	30
FLA ²⁾ max. 25 A, 600 V	115	2	--	4	65	65	65	30	30
NEMA size 1	200	3	5	5	65	65	65	30	30
	230	3	7 1/2	6.3	65	65	65	30	30
	460	--	15	8	65	65	65	30	30
	575/600	--	20	10	65	65	65	30	30
				12.5	65	65	65	30	30
				16	65	65	65	10	10
				20	65	65	65	10	10
				22	65	65	65	10	10
				25	65	65	65	10	10
Size S2									
3RV10 31/3RV11 31, 3RV13 31			16	65	65	65	65	30	25
FLA ²⁾ max. 50 A, 600 V	115	3	--	20	65	65	65	30	25
NEMA size 2	200	7 1/2	15	25	65	65	65	30	25
	230	10	20	32	65	65	65	30	25
	460	--	40	40	65	65	65	30	25
	575/600	--	50	45	65	65	65	30	25
				50	65	65	65	30	25
Size S3									
3RV10 41/3RV10 42, 3RV11 42, 3RV13 41/3RV13 42			16	65	65	65	65	30	30
FLA ²⁾ max. 99 A, 600 V	115	7 1/2	--	20	65	65	65	30	30
NEMA size 3	200	20	30	25	65	65	65	30	30
	230	20	40	32	65	65	65	30	30
	460	--	75	40	65	65	65	30	30
	575/600	--	100	50	65	65	65	30	30
				63	65	65	65	30	30
				75	65	65	65	30	30
				90	65	65	65	10	10
				100	65	65	65	10	10

1) hp rating = Power rating in horse power (maximum motor rating).

2) FLA = Full Load Amps/Motor full load current.

3) Complies with "short-circuit breaking capacity" according to UL/CSA.

3RV Motor Starter Protectors/Circuit Breakers up to 100 A

General data

3RV10 motor starter protectors as "Manual Motor Controllers Suitable for Tap Conductor Protection in Group Installations"

The application as "Manual Motor Controllers Suitable for Tap Conductor Protection in Group Installations" is only available from UL.

CSA does not recognize this approval! When the motor starter protector is used as a "Manual Motor Controller Suitable for Tap Conductor Protection in Group Installations", it must always be combined with upstream short-circuit protection. As short-circuit-protection device, approved fuses or a motor starter

protector according to UL 489 can be used.

These devices must be dimensioned according to the National Electrical Code.

The 3RV10 motor starter protectors are approved as "Manual Motor Controllers Suitable for Tap Conductor Protection in Group Installations" under the following file number:

- UL File No. 47705, CCN: NLRV.

Motor starter protectors	hp rating ¹⁾ for FLA ²⁾ max.		Rated current I_n	240 V AC	Up to 480 V AC	Up to 600 V AC
	1-phase	3-phase		UL I_{bc} ³⁾	UL I_{bc} ³⁾	UL I_{bc} ³⁾
Type	V		A	kA	kA	kA
Size S00						
3RV10 11						
			0.16 ... 0.8	65	65	10
FLA ²⁾ max. 8 A, 480 V	115	1/3	1	65	65	10
	200	3/4	1.25	65	65	10
NEMA size 0	230	1	2	65	65	10
	460	--	3.2	65	65	10
	575/600	--	4	65	65	10
			5	65	65	10
			6.3	65	65	10
			8	65	65	10
Size S0						
3RV10 21						
			0.16 ... 1.6	65	65	30
FLA ²⁾ max.	115	2	2	65	65	30
22 A, 480 V	200	3	2.5	65	65	30
12.5 A, 600 V	230	3	3.2	65	65	30
	460	--	4	65	65	30
NEMA size 1	575/600	--	5	65	65	30
			6.3	65	65	30
			8	65	65	30
			10	65	65	30
			12.5	65	65	30
Size S2						
3RV10 31						
			16	65	65	25
FLA ²⁾ max.	115	3	20	65	65	25
50 A, 600 V	200	7 1/2	25	65	65	25
NEMA size 2	230	10	32	65	65	25
	460	--	40	65	65	25
	575/600	--	45	65	65	25
			50	65	65	25
Size S3						
3RV10 4.						
			16	65	65	30
FLA ²⁾ max.	115	7 1/2	20	65	65	30
100 A, 480 V	200	20	25	65	65	30
75 A, 600 V	230	20	32	65	65	30
	460	--	40	65	65	30
NEMA size 3	575/600	--	50	65	65	30
			63	65	65	30
			75	65	65	30
			90	65	65	--
			100	65	65	--

¹⁾ hp rating = Power rating in horse power (maximum motor rating).

²⁾ FLA = Full Load Amps/Motor full load current.

³⁾ Complies with "short-circuit breaking capacity" according to UL.

3RV Motor Starter Protectors/Circuit Breakers up to 100 A

General data

3RV10 motor starter protectors as "Self-Protected Combination Motor Controllers (Type E)"

A line-side 1-inch clearance in air and 2-inch creepage distance is required for "Self-Protected Combination Motor Controllers" for approval according to UL 508.

Therefore, 3RV10 motor starter protectors of size S0 and S3 are approved to UL 508 in combination with the terminal blocks listed below.

The basic units of the 3RV10 motor starter protectors size S2 comply with the required clearance in air and creepage distances.

CSA does not demand these extended air/creepage distances. According to CSA, these terminal blocks can be omitted when the device is used as a "Self-Protected Combination Motor Controller".

The 3RV10 motor starter protectors are approved as "Self-Protected Combination Motor Controllers" under the following file numbers:

- UL File No. E156943, CCN: NKJH,
- CSA Master Contract 165071, Product Class: 3211 08.

Motor starter protectors	hp rating ¹⁾ for FLA ²⁾ max.		Rated current I_n	Up to 240 V AC		Up to 480 Y/277 V AC		Up to 600 Y/347 V AC		
	Type	V		1-phase	3-phase	UL $I_{bc}^{(3)}$	CSA $I_{bc}^{(3)}$	UL $I_{bc}^{(3)}$	CSA $I_{bc}^{(3)}$	UL $I_{bc}^{(3)}$
Size S0										
3RV10 21 + 3RV19 28-1H⁴⁾				0.16 ... 1.6	65	65	65	65	30	30
FLA ²⁾ max.	115	2	--	2	65	65	65	65	30	30
22 A, 480 V	200	3	5	2.5	65	65	65	65	30	30
12.5 A, 600 V	230	3	7 1/2	3.2	65	65	65	65	30	30
NEMA size 1	460	--	15	4	65	65	65	65	30	30
	575/600	--	10	5	65	65	65	65	30	30
				6.3	65	65	65	65	30	30
				8	65	65	65	65	30	30
				10	65	65	65	65	30	30
				12.5	65	65	65	65	30	30
				16	65	65	65	65	--	--
				20	65	65	65	65	--	--
				22	65	65	65	65	--	--
Size S2										
3RV10 31				16	65	65	65	65	25	25
FLA ²⁾ max.	115	3	--	20	65	65	65	65	25	25
50 A, 600 V	200	7 1/2	15	25	65	65	65	65	25	25
NEMA size 2	230	10	20	32	65	65	65	65	25	25
	460	--	40	40	65	65	65	65	25	25
	575/600	--	50	45	65	65	65	65	25	25
				50	65	65	65	65	25	25
Size S3										
3RV10 41 + 3RT19 46-4GA07⁴⁾				16	65	65	65	65	30	30
FLA ²⁾ max.	115	10	--	20	65	65	65	65	30	30
100 A, 480 V	200	20	30	25	65	65	65	65	30	30
75 A, 600 V	230	20	40	32	65	65	65	65	30	30
	460	--	75	40	65	65	65	65	30	30
NEMA size 3	575/600	--	75	50	65	65	65	65	30	30
				63	65	65	65	65	30	30
				75	65	65	65	65	30	30
				90	65	65	65	65	--	--
				100	65	65	65	65	--	--

¹⁾ hp rating = Power rating in horse power (maximum motor rating).

²⁾ FLA = Full Load Amps/Motor full load current.

³⁾ Complies with "short-circuit breaking capacity" according to UL/CSA.

⁴⁾ Not required for CSA.

3RV Motor Starter Protectors/Circuit Breakers up to 100 A

General data

3RV17 and 3RV18 circuit breakers

These circuit breakers are approved according to UL 489 and CSA C22.2 No. 5-02 for 100 % rated current (100 % rated breaker). They can be used therefore as upstream short-circuit protective devices for "Manual Motor Controllers" and "Manual Motor Controllers Suitable for Tap Conductor Protection in Group Installations".

The 3RV17 and 3RV18 circuit breakers are approved under the following file numbers:

- UL File No. E235044, CCN: DIVQ,
- CSA Master Contract 165071, Product Class: 1432 01.

Circuit breakers	Rated current I_n	240 V AC		480 Y/277 V AC		480 V AC		600 Y/347 V AC	
		UL $I_{bc}^{1)}$	CSA $I_{bc}^{1)}$	UL $I_{bc}^{1)}$	CSA $I_{bc}^{1)}$	UL $I_{bc}^{1)}$	CSA $I_{bc}^{1)}$	UL $I_{bc}^{1)}$	CSA $I_{bc}^{1)}$
Type	A	kA	kA	kA	kA	kA	kA	kA	kA
Size S0									
3RV17 21	0.16	50	50	50	50	--	--	10	10
	0.2	50	50	50	50	--	--	10	10
	0.25	50	50	50	50	--	--	10	10
	0.32	50	50	50	50	--	--	10	10
	0.4	50	50	50	50	--	--	10	10
	0.5	50	50	50	50	--	--	10	10
	0.63	50	50	50	50	--	--	10	10
	0.8	50	50	50	50	--	--	10	10
	1	50	50	50	50	--	--	10	10
	1.25	50	50	50	50	--	--	10	10
	1.6	50	50	50	50	--	--	10	10
	2	50	50	50	50	--	--	10	10
	2.5	50	50	50	50	--	--	10	10
	3.2	50	50	50	50	--	--	10	10
	4	50	50	50	50	--	--	10	10
	5	50	50	50	50	--	--	10	10
	6.3	50	50	50	50	--	--	10	10
	8	50	50	50	50	--	--	10	10
	10	50	50	50	50	--	--	--	--
	12.5	50	50	50	50	--	--	--	--
	15	50	50	50	50	--	--	--	--
	20	50	50	50	50	--	--	--	--
	22	50	50	50	50	--	--	--	--
3RV18 21	0.16	50	50	50	50	--	--	10	10
	0.2	50	50	50	50	--	--	10	10
	0.25	50	50	50	50	--	--	10	10
	0.32	50	50	50	50	--	--	10	10
	0.4	50	50	50	50	--	--	10	10
	0.5	50	50	50	50	--	--	10	10
	0.63	50	50	50	50	--	--	10	10
	0.8	50	50	50	50	--	--	10	10
	1	50	50	50	50	--	--	10	10
	1.25	50	50	50	50	--	--	10	10
	1.6	50	50	50	50	--	--	10	10
	2	50	50	50	50	--	--	10	10
	2.5	50	50	50	50	--	--	10	10
	3.2	50	50	50	50	--	--	10	10
	4	50	50	50	50	--	--	10	10
	5	50	50	50	50	--	--	10	10
	6.3	50	50	50	50	--	--	10	10
	8	50	50	50	50	--	--	--	--
	10	50	50	50	50	--	--	--	--
	12.5	50	50	50	50	--	--	--	--
	15	50	50	50	50	--	--	--	--
	20	50	50	50	50	--	--	--	--
Size S3									
3RV17 42	10	65	65	65	65	65	65	20	20
	15	65	65	65	65	65	65	20	20
	20	65	65	65	65	65	65	20	20
	25	65	65	65	65	65	65	20	20
	30	65	65	65	65	65	65	20	20
	35	65	65	65	65	--	--	20	20
	40	65	65	65	65	--	--	20	20
	45	65	65	65	65	--	--	20	20
	50	65	65	65	65	--	--	20	20
	60	65	65	65	65	--	--	20	20
	70	65	65	65	65	--	--	10	10

¹⁾ Complies with "short-circuit breaking capacity" according to UL.

3RV Motor Starter Protectors/Circuit Breakers up to 100 A

General data

Rated data of the auxiliary switches and signal switches

Type 3RV19		Lateral auxiliary switch with 1 NO + 1 NC, 2 NO, 2 NC, 2 NO + 2 NC Signal switches		Transverse auxiliary switches with 1 CO contact		1 NO + 1 NC, 2 NO	
		Max. rated voltage Acc. to NEMA (UL) Acc. to NEMA (CSA)	V AC V AC	600 600			
Uninterrupted current Switching capacity	A	10 A600 Q300		5 B600 R300		2.5 C300 R300	

Voltage transformer circuit breakers

General technical specifications

Type		3RV16 11-1AG14	3RV16 11-1CG14	3RV16 11-1DG14
Rated current I_n	A	1.4	2.5	3
Ambient temperature				
• During storage/transport	°C	-50 ... +80		
• During operation	°C	-20 ... +60 (up to +70 °C is possible with current reduction)		
Rated operational voltage U_e	V	400		
Rated frequency	Hz	16.66 ... 60		
Rated insulation voltage U_i	V	690		
Short-circuit breaking capacity I_{cu} at 400 V AC	kA	50		
Set value of the thermal overload release	A	1.4	2.5	3
Response value of the instantaneous electronic trip unit	A	6 ± 20 %	10.5 ± 20 %	20 ± 20 %
Tripping time of the instantaneous electronic trip unit	ms	Approx. 6 at 12 A	Approx. 6 at 20 A	Approx. 6 at 40 A
Internal resistance				
• In cold state	Ω	> 0.25 ± 6.5 %		
• In heated state	Ω	> 0.30 ± 6.5 %		
Shock resistance acc. to IEC 68 Part 2-27	g	15		
Degree of protection acc. to IEC 60529		IP20		
Touch protection acc. to EN 50274		Finger-safe		
Endurance				
• Mechanical	Operating cycles	10000		
• Electrical	Operating cycles	10000		
Permissible mounting positions		Any		

Type		3RV16 11-1AG14	3RV16 11-1CG14	3RV16 11-1DG14
Conductor cross-sections, main circuit, 1 or 2 conductors				
Connection type		 Screw terminals		
Terminal screw		Pozi driv size 2		
Conductor cross-sections				
• Solid	mm ²	2 x (0.5 ... 1.5) ¹⁾ , 2 x (0.75 ... 2.5) ¹⁾ , max. 4		
• Finely stranded with end sleeve	mm ²	2 x (0.5 ... 1.5) ¹⁾ , 2 x (0.75 ... 2.5) ¹⁾		
• Stranded	mm ²	2 x (0.5 ... 1.5) ¹⁾ , 2 x (0.75 ... 2.5) ¹⁾ , max. 4		
Auxiliary switch for blocking the distance protection				
• With defined lateral assignment for blocking distance protection		1 changeover contact (for use as 1 NO or 1 NC)		
• Rated operational voltage U_e (AC voltage)	V	250		
• Rated operational current I_e /AC-14 at $U_e = 250$ V	A	0.5		
• Rated operational current I_e /AC-14 at $U_e = 125$ V	A	1		
• Rated operational voltage U_e (DC voltage L/R 200 ms)	V	250		
• Rated operational current I_e /DC-13 at $U_e = 250$ V	A	0.27		
• Rated operational current I_e /DC-13 at $U_e = 125$ V	A	0.44		
Short-circuit protection for auxiliary circuit				
• Melting fuse gL/gG	A	10		
• Miniature circuit breaker, C characteristic	A	6 (prospective short-circuit current < 0.4 kA)		
Auxiliary switches for other signaling purposes				

For technical specifications see "Mountable Accessories"

¹⁾ If two different conductor cross-sections are connected to one clamping point, both cross-sections must lie in the range specified. If identical cross-sections are used, this restriction does not apply.

Characteristic curves

The time/current characteristic, the current limiting characteristics and the I^2t characteristic curves were determined according to EN/IEC 60947.

The tripping characteristic of the inverse-time delayed overload release (thermal overload releases, 'a' releases) for DC and AC with a frequency of 0 Hz to 400 Hz applies for the time/current characteristic.

The characteristic curves apply to the cold state; at operating temperature, the tripping times of the thermal releases are reduced to approximately 25 %.

Under normal operating conditions, all three poles of the device must be loaded. The three main current paths must be connected in series in order to protect single-phase or DC loads.

With two-pole and three-pole loading, the maximum deviation in the tripping time of 3 times the setting current and upwards is $\pm 20\%$ and thus in accordance with EN 60079.

The tripping characteristics for the instantaneous, electromagnetic electronic trip units (short-circuit releases, 'n' releases) are based on the rated current I_n that also represents the maximum value of the setting range for motor starter protectors with adjustable overload releases. If the current is set to a lower value, the tripping current of the 'n' release is increased by a corresponding factor.

The characteristic curves of the electromagnetic electronic trip units apply to frequencies of 50 Hz/60 Hz. Appropriate correction factors must be used for lower frequencies down to $16^{2/3}$ Hz, for higher frequencies up to 400 Hz and for DC.

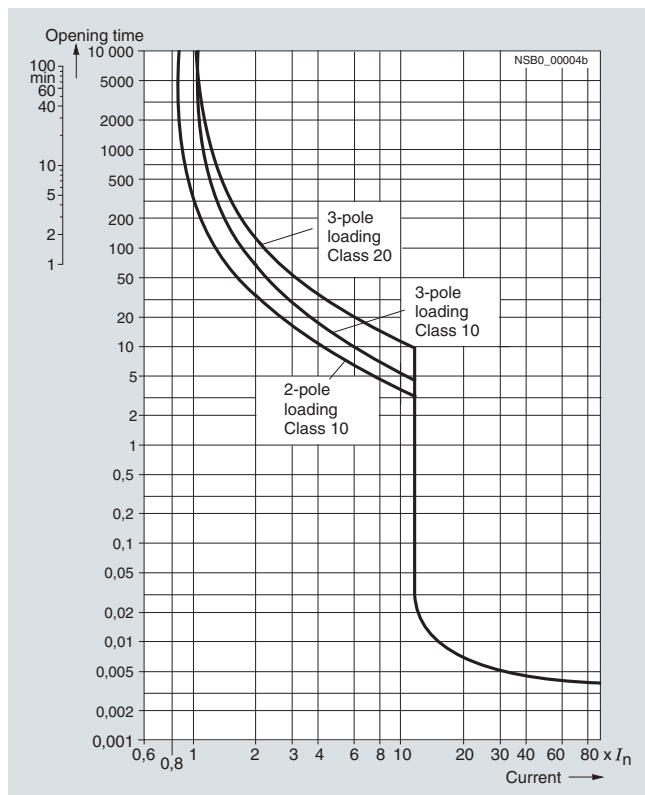

Schematic representation of typical time/current characteristic of 3RV10

The above characteristic curve for the motor starter protector relates to a specific setting range. It is, however, also valid as a schematic representation of motor starter protectors with other current ranges.

Time/current characteristic curves, current limiting characteristic curves and I^2t curves can be ordered from "Technical Assistance":

- Either by e-mail to: technical-assistance@siemens.com
- Or on the Internet: <http://www.siemens.com/automation/service&support>

3RV16 voltage transformer circuit breakers up to 3 A

The specified tripping characteristics of the thermal overload release (a) correspond to the mean value of the scatter band in the cold state. At operating temperature, these times are reduced to approximately 25 % of the specified values.

The characteristic curves below are schematic representations. Precise characteristic curves can be ordered from "Technical Assistance":

- Either by e-mail to: technical-assistance@siemens.com
- Or on the Internet: <http://www.siemens.com/automation/service&support>

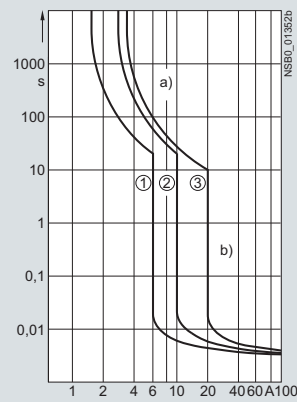

- ① 1.4 A / 6 A
- ② 2.5 A / 10.5 A
- ③ 3 A / 20 A
- a) Thermal overload release
- b) Instantaneous electromagnetic trip unit

3RV Motor Starter Protectors/Circuit Breakers up to 100 A

General data

Dimensional drawings

3RV1 motor starter protectors, size S00

3RV10 11, 3RV16

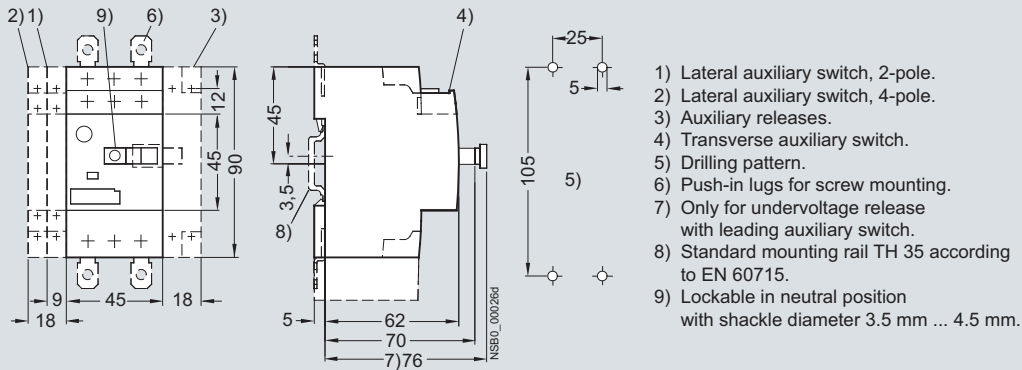

3RV1 motor starter protectors, size S0

3RV10 21, 3RV13 21, 3RV14 21

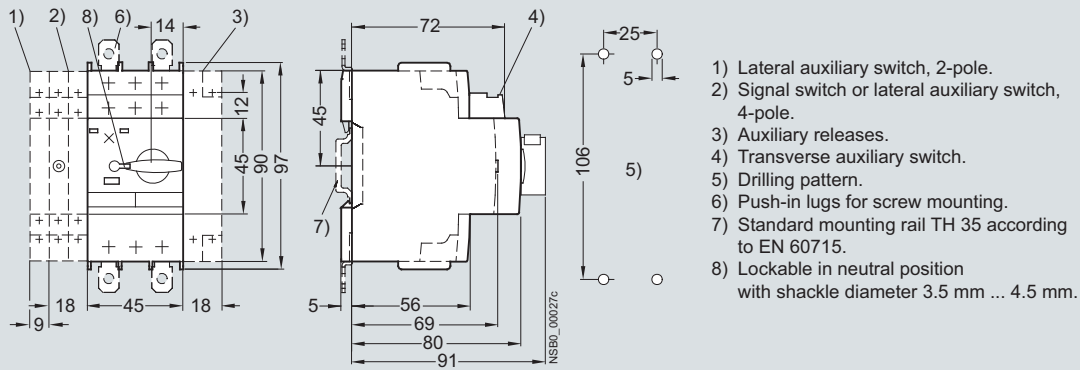

3RV1 motor starter protectors, size S2

3RV10 31, 3RV13 31, 3RV14 31

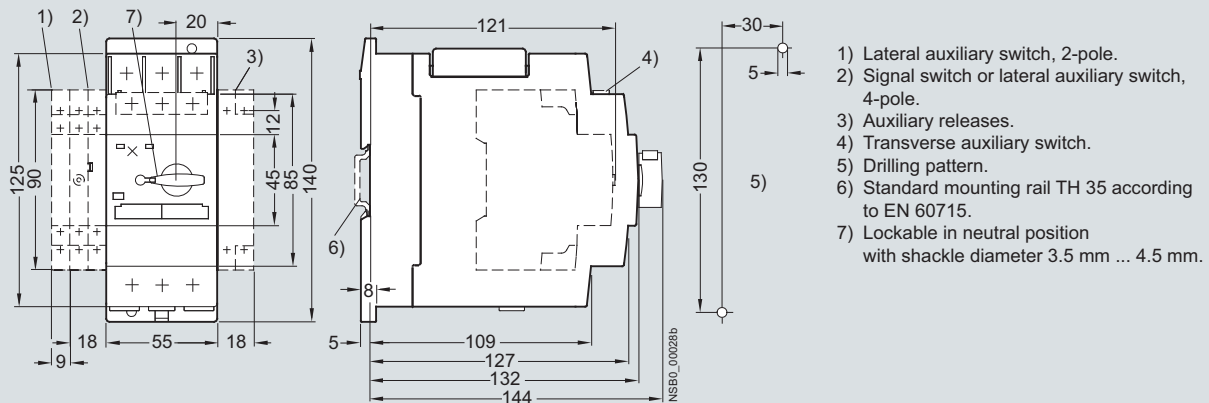

3RV Motor Starter Protectors/Circuit Breakers up to 100 A

General data

3RV1 motor starter protectors, size S3

3RV10 4, 3RV13 4

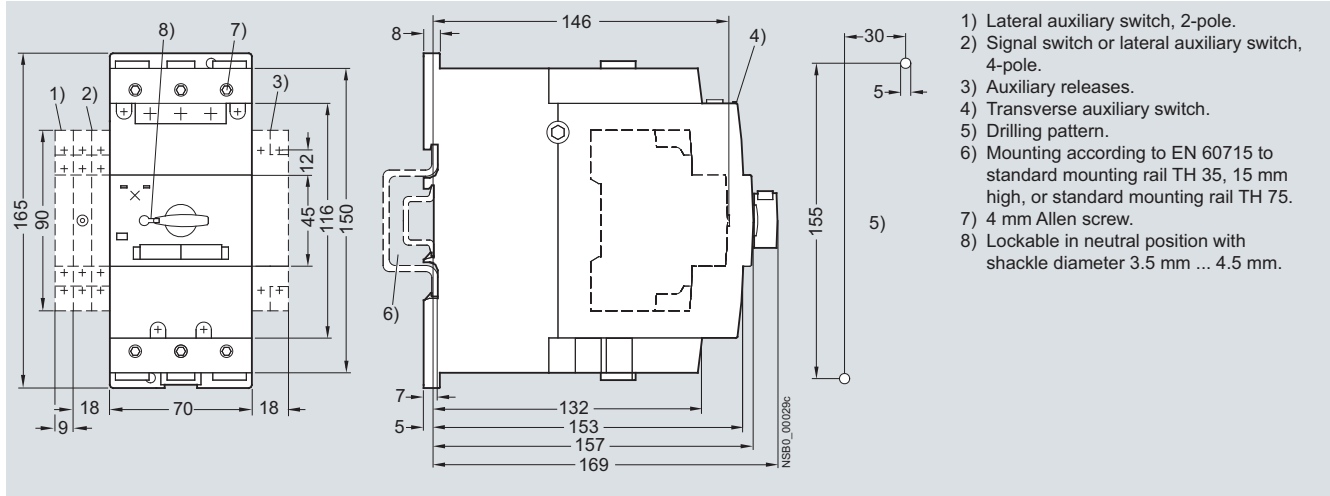

3RV11 motor starter protectors, size S0

3RV11 21

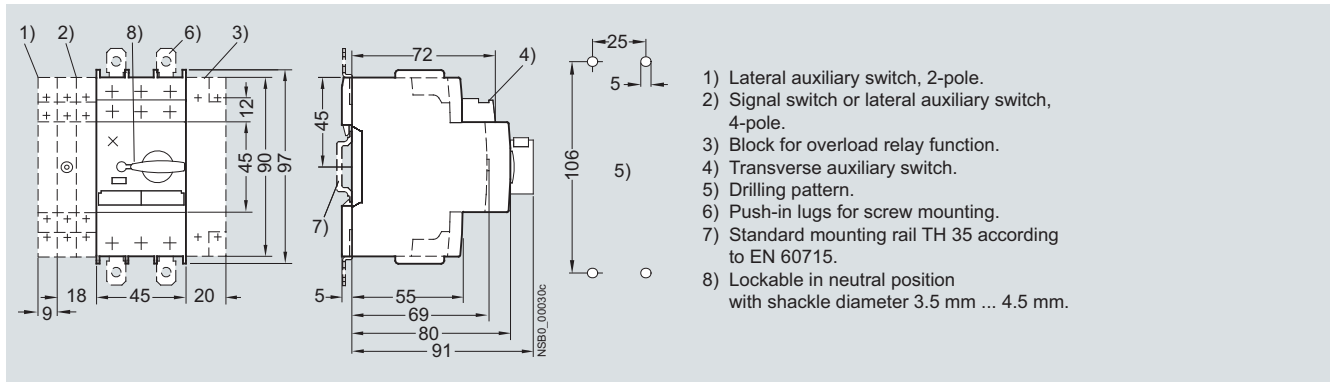

3RV11 motor starter protectors, size S2

3RV11 31

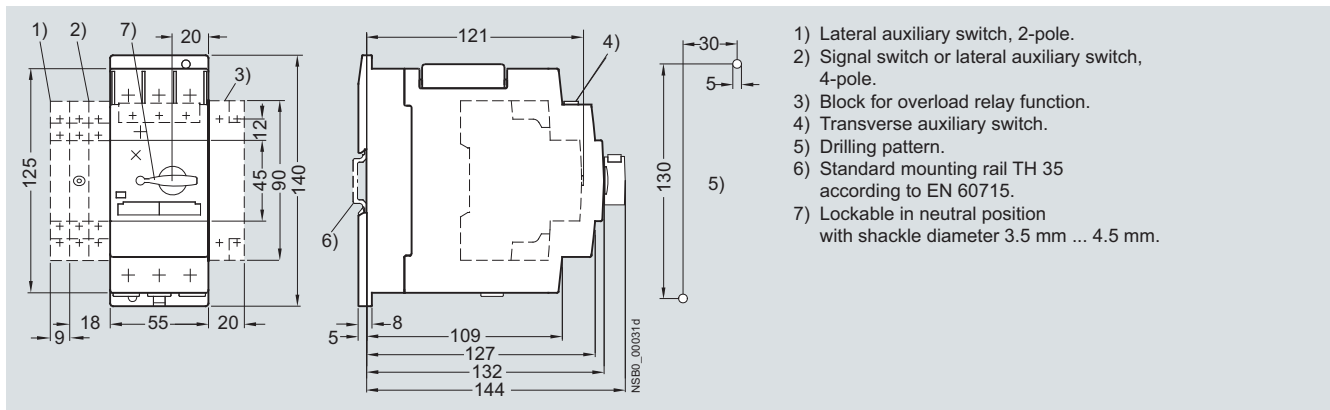

3RV Motor Starter Protectors/Circuit Breakers up to 100 A

General data

3RV11 motor starter protectors, size S3

3RV11 42

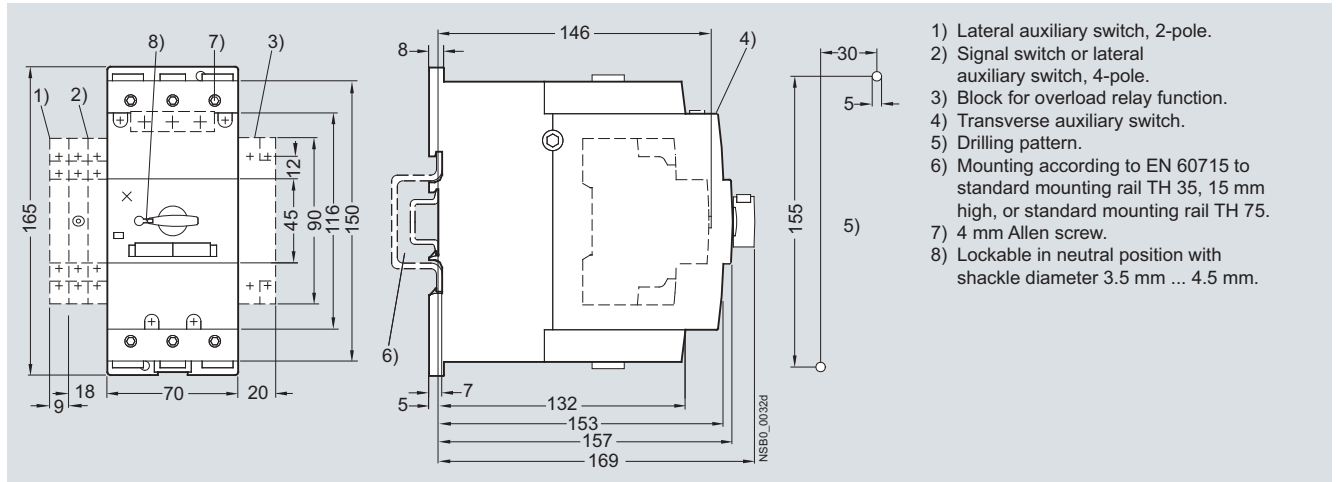

3RV17 and 3RV18 circuit breakers, size S0

3RV17 21, 3RV18 21

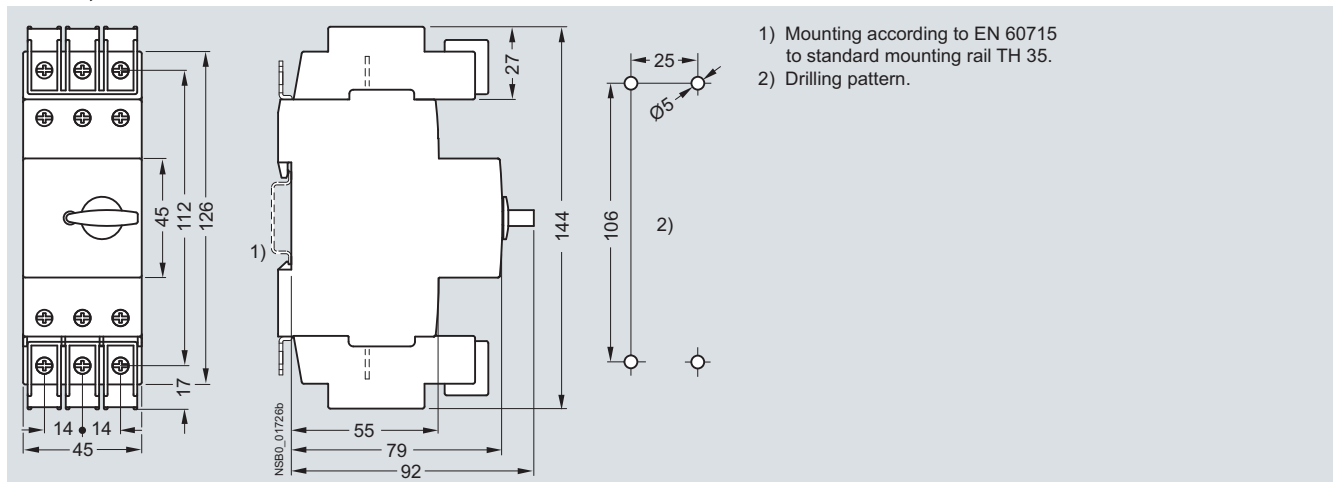

3RV17 circuit breakers, size S3

3RV17 42

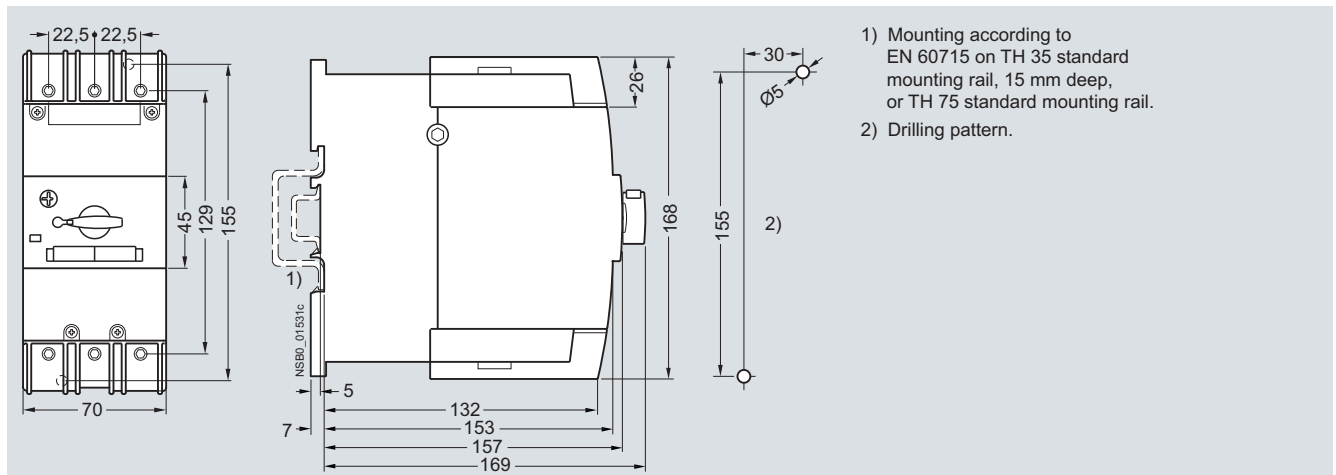

3RV Motor Starter Protectors/Circuit Breakers up to 100 A

General data

Schematics

Internal circuit diagrams

Motor starter protector/circuit breaker

3RV10 ..,
3RV14 ..,
3RV16 11-0BD10,
3RV17 ..,
3RV18 ..

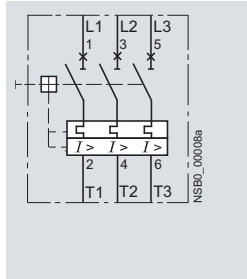

Motor starter protector with overload relay function

3RV11 ..

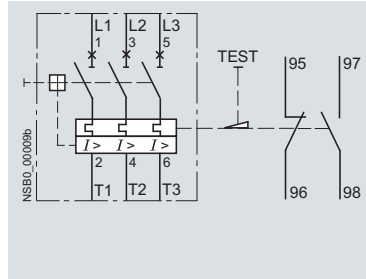

Motor starter protector

3RV13 ..

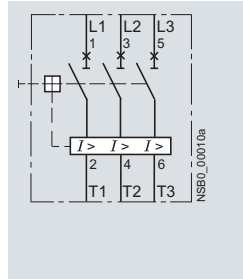

Voltage transformer circuit breaker

3RV16 11-1.G14

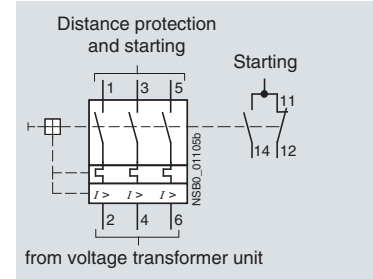

Switching examples

3RV11 motor starter protector with overload relay function

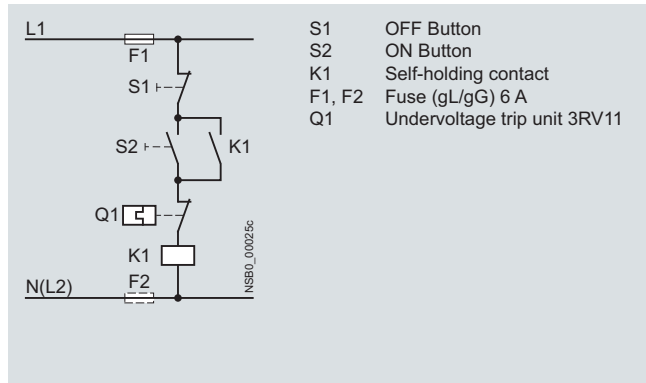

3RV16 11-1.G14 voltage transformer circuit breaker

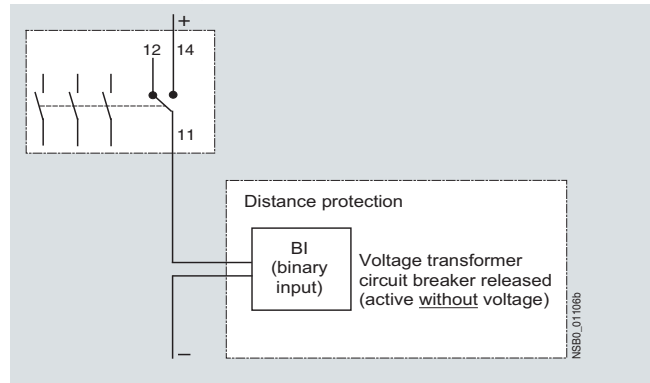

Note:

When using the NO contact to connect the voltage transformer circuit breaker, the binary input of the distance protection device (Siemens 7 SA xxx) should be set to "active without voltage". This connection type is used for additional monitoring of correct wiring.

More information

Conversion of voltage transformer circuit breakers 3VU13 to 3RV1

The 3VU13 voltage transformer motor starter protectors previously available have been discontinued. The 3RV1 voltage transformer motor starter protectors are offered as replacement types.

Previous type	Replacement type
3VU13 11-6HR00	3RV16 11-1CG14
3VU13 21-6HR00	3RV16 11-1CG14 + 3RV19 01-1A
3VU13 11-6JR00	3RV16 11-1DG14

3RV Motor Starter Protectors/Circuit Breakers up to 100 A

Accessories

Mountable accessories

Overview

Mounting location and function

The 3RV1 motor starter protectors/circuit breakers have three main contact elements. In order to achieve maximum flexibility, auxiliary switches, signal switches, auxiliary trip units and isolator modules can be supplied separately.

These components can be fitted as required on the circuit breakers/motor starter protectors without using tools.

For overview graphic see "General Data" --> "Overview".

<p>Front side</p> <p><u>Notes:</u></p> <ul style="list-style-type: none"> • A maximum of 4 auxiliary contacts with auxiliary switches can be attached to each motor starter protector. • Transverse auxiliary switches must not be used for the 3RV17 and 3RV18 circuit breakers. 	<p>Transverse auxiliary switches</p> <p>1 NO + 1 NC or 2 NO or 1 CO contact</p>	<p>An auxiliary switch block can be inserted transversely on the front. The overall width of the motor starter protectors remains unchanged.</p>
<p>Left-hand side</p> <p><u>Notes:</u></p> <ul style="list-style-type: none"> • A maximum of 4 auxiliary contacts with auxiliary switches can be attached to each motor starter protector/circuit breaker. • Auxiliary switches (2 contacts) and signal switches can be mounted separately or together. • The signal switch cannot be used for the 3RV17 and 3RV18 circuit breakers. 	<p>Lateral auxiliary switches (2 contacts)</p> <p>1 NO + 1 NC or 2 NO or 2 NC</p>	<p>One of the three auxiliary switches can be mounted laterally for each motor starter protector/circuit breaker. The contacts of the auxiliary switch close and open together with the main contacts of the motor starter protector.</p> <p>The overall width of the lateral auxiliary switch with 2 contacts is 9 mm.</p>
	<p>Lateral auxiliary switches (4 contacts)</p> <p>2 NO + 2 NC</p>	<p>One auxiliary switch can be mounted laterally for each motor starter protector. The contacts of the auxiliary switch close and open together with the main contacts of the motor starter protector/circuit breaker.</p> <p>The overall width of the lateral auxiliary switch with 4 contacts is 18 mm.</p>
	<p>Signal switches for sizes S0, S2 and S3</p> <p>Tripping 1 NO + 1 NC Short-circuit 1 NO + 1 NC</p>	<p>One signal switch can be mounted at the side of each motor starter protector with a rotary operating mechanism.</p> <p>The signal switch has two contact systems.</p> <p>One contact system always signals <u>tripping</u> irrespective of whether this was caused by a short-circuit, an overload or an auxiliary trip unit. The other contact system only switches in the event of a short-circuit. There is no signaling as a result of <u>switching off</u> with the handle.</p> <p>In order to be able to switch on the motor starter protector again after a short-circuit, the signal switch must be reset manually after the error cause has been eliminated.</p> <p>The overall width of the signal switch is 18 mm.</p>
<p>Right-hand side</p> <p><u>Notes:</u></p> <ul style="list-style-type: none"> • One auxiliary trip unit can be mounted per motor starter protector/circuit breaker. • Accessories cannot be mounted at the right-hand side of the 3RV11 motor starter protectors with overload relay function. 	<p>Auxiliary trip units</p>	<p><u>Shunt trip units</u></p> <p>For remote-controlled tripping of the motor starter protector/circuit breaker. The trip unit coil should only be energized for short periods (see schematics).</p>
	<p>or</p>	
	<p><u>Undervoltage trip units</u></p>	<p>Trips the motor starter protector when the voltage is interrupted and prevents the motor from being restarted accidentally when the voltage is restored. Used for remote-controlled tripping of the circuit breaker/motor starter protector.</p> <p>Particularly suitable for EMERGENCY-STOP disconnection by way of the corresponding EMERGENCY-STOP pushbutton according to EN 60204-1.</p>
	<p>or</p>	
	<p><u>Undervoltage trip unit with leading auxiliary contacts (2 NO)</u></p>	<p>Function and use as for the undervoltage trip unit without leading auxiliary contacts, but with the following additional function: the auxiliary contacts will open in switch position OFF to deenergize the coil of the undervoltage trip unit, thus interrupting energy consumption. In the "tripped" position, these auxiliary contacts are not guaranteed to open. The leading contacts permit the motor starter protector/circuit breaker to reclose.</p> <p>The overall width of the auxiliary trip unit is 18 mm.</p>
<p>Top</p> <p><u>Notes:</u></p> <ul style="list-style-type: none"> • The isolator module cannot be used for the 3RV17 and 3RV18 circuit breakers. • The isolator module covers the terminal screws of the transverse auxiliary switch. If the isolator module is used, we therefore recommend that either the lateral auxiliary switches be fitted or that the isolator module not be mounted until the auxiliary switch has been wired. 	<p>Isolator modules for sizes S0 and S2</p>	<p>Isolator modules can be mounted to the upper terminal end of motor starter protectors of sizes S0 and S2.</p> <p>The supply cable is connected to the motor starter protector through the isolator module.</p> <p>The plug can only be unplugged when the motor starter protector is open and isolates all 3 poles of the motor starter protector from the network. The shock-protected isolation point is clearly visible and secured with a padlock to prevent reinsertion of the plug.</p>

For a complete overview of which accessories can be used for the various motor starter protectors see "Introduction" --> "Overview" --> "Motor Starter Protectors".

3RV Motor Starter Protectors/Circuit Breakers up to 100 A

Accessories

Mountable accessories

Technical specifications

Front transverse auxiliary switches

		Switching capacity for different voltages	
		1 CO contact	1 NO + 1 NC, 2 NO
Rated operational current I_e			
• At AC-15, alternating voltage			
- 24 V	A	4	2
- 230 V	A	3	0.5
- 400 V	A	1.5	--
- 690 V	A	0.5	--
• At AC-12 = I_{th} , alternating voltage			
- 24 V	A	10	2.5
- 230 V	A	10	2.5
- 400 V	A	10	--
- 690 V	A	10	--
• At DC-13, direct voltage L/R 200 ms			
- 24 V	A	1	1
- 48 V	A	--	0.3
- 60 V	A	--	0.15
- 110 V	A	0.22	--
- 220 V	A	0.1	--
Minimum load capacity	V	17	
	mA	1	

Front transverse solid-state compatible auxiliary switches

			1 CO contact
• Rated operational voltage U_e	Alternating voltage	V	250
• Rated operational current $I_e/AC-14$	at $U_e = 250$ V	A	0.5
• Rated operational current $I_e/AC-14$	at $U_e = 125$ V	A	1
• Rated operational voltage U_e	Direct voltage L/R 200 ms	V	250
• Rated operational current $I_e/DC-13$	at $U_e = 250$ V	A	0.27
• Rated operational current $I_e/DC-13$	at $U_e = 125$ V	A	0.44
Minimum load capacity	V	5	
	mA	1	

Lateral auxiliary switches with signal switch

			Switching capacity for different voltages: Lateral auxiliary switch with 1 NO + 1 NC, 2 NO, 2 NC, 2 NO + 2 NC; signal switch
Rated operational current I_e			
• At AC-15, alternating voltage			
- 24 V	A	6	
- 230 V	A	4	
- 400 V	A	3	
- 690 V	A	1	
• At AC-12 = I_{th} , alternating voltage			
- 24 V	A	10	
- 230 V	A	10	
- 400 V	A	10	
- 690 V	A	10	
• At DC, direct voltage L/R 200 ms			
- 24 V	A	2	
- 110 V	A	0.5	
- 220 V	A	0.25	
- 440 V	A	0.1	
Minimum load capacity	V	17	
	mA	1	

Auxiliary trip units

		Undervoltage trip units	Shunt trip units
Power consumption			
• During pick-up			
- AC voltages	VA/W	20.2/13	20.2/13
- DC voltages	W	20	13 ... 80
• During uninterrupted duty			
- AC voltages	VA/W	7.2/2.4	--
- DC voltages	W	2.1	--
Response voltage			
• Tripping	V	0.35 ... 0.7 × U_s	0.7 ... 1.1 × U_s
• Pickup	V	0.85 ... 1.1 × U_s	--
Maximum opening time	ms	20	

3RV Motor Starter Protectors/Circuit Breakers up to 100 A Accessories

Mountable accessories

Short-circuit protection for auxiliary and control circuits

Melting fuses gL/gG	A	10
Miniature circuit breaker , C characteristic	A	6 ¹⁾

1) Prospective short-circuit current < 0.4 kA.

Conductor cross-sections for auxiliary and control circuits

Connection type

Terminal screw

Prescribed tightening torque

Conductor cross-sections (1 or 2 conductors)

- Solid
- Finely stranded with end sleeve
- Stranded
- AWG cables

Connection type

Conductor cross-sections (1 or 2 conductors connectable)

- Solid
- Finely stranded with end sleeve
- Finely stranded without end sleeve
- AWG cables, solid or stranded

Max. external diameter of the conductor insulation

1) If two different conductor cross-sections are connected to one clamping point, both cross-sections must lie in the range specified. If identical cross-sections are used, this restriction does not apply.

Screw terminals

Pozidriv size 2

Nm 0.8 ... 1.2

mm² 2 x (0.5 ... 1.5)¹⁾/2 x (0.75 ... 2.5)¹⁾

mm² 2 x (0.5 ... 1.5)¹⁾/2 x (0.75 ... 2.5)¹⁾

mm² 2 x (0.5 ... 1.5)¹⁾/2 x (0.75 ... 2.5)¹⁾

AWG 2 x (18 ... 14)

Cage Clamp terminals²⁾³⁾

mm² 2 x (0.25 ... 2.5)

mm² 2 x (0.25 ... 1.5)

mm² 2 x (0.25 ... 2.5)

AWG 2 x (24 ... 14)

mm 3.6

2) With conductor cross-sections of ≤ 1 mm² an "insulation stop" must be used; see "Accessories", "Contactors and Contactor Assemblies".

3) For corresponding 8WA2 803 or 8WA2 880 opening tools see "Accessories".

Schematics

Internal circuit diagrams

Transverse auxiliary switches

1 CO

1 NO + 1 NC

2 NO

3RV19 01-1D,
3RV19 01-1G

3RV19 01-1E,
3RV19 01-2E

3RV19 01-1F,
3RV19 01-2F

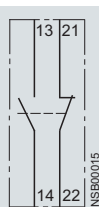

Lateral auxiliary switches

1 NO + 1 NC

2 NO

2 NC

2 NO + 2 NC

3RV19 01-1A,
3RV19 01-2A

3RV19 01-1B,
3RV19 01-2B

3RV19 01-1C,
3RV19 01-2C

3RV19 01-1J

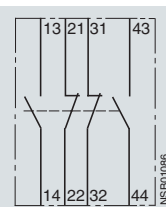

Signal switches

3RV19 21-1M

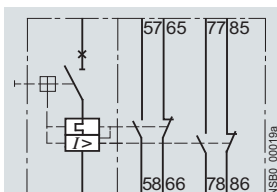

Auxiliary trip units

Undervoltage trip units
3RV19 02-1A..

Undervoltage trip units with leading auxiliary contacts
2 NO
3RV19 12-1C..
3RV19 22-1C..

Shunt trip units
3RV19 02-1D.0

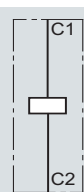
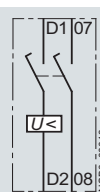
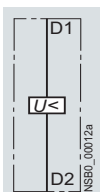

3RV Motor Starter Protectors/Circuit Breakers up to 100 A Accessories

Mountable accessories

Circuit diagrams

Undervoltage trip unit

3RV19 02-1A..., 3RV19 .2-1C..

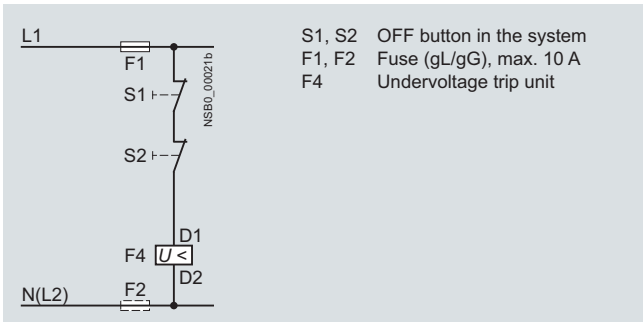

Shunt trip unit

3RV19 02-1D.0

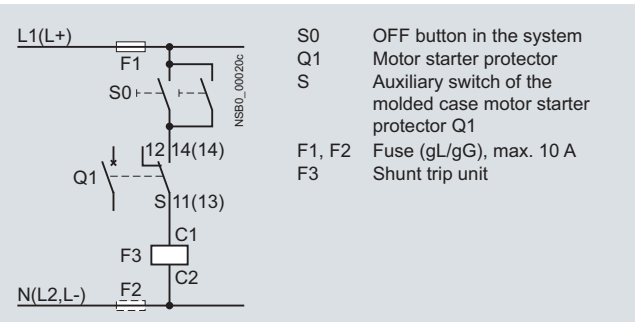

Switching examples

3RV1 motor starter protector with 3RV19 21-1M signal switch

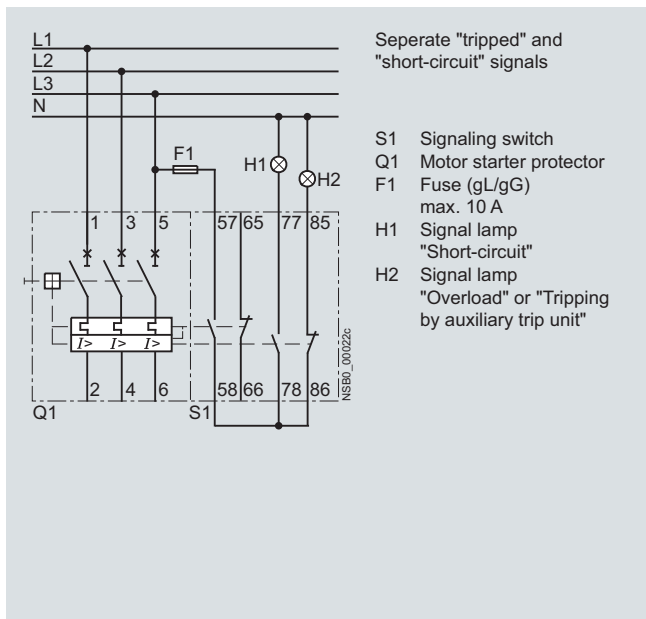

Motor starter protectors tripped by means of pushbutton or EMERGENCY-STOP pushbutton in the system

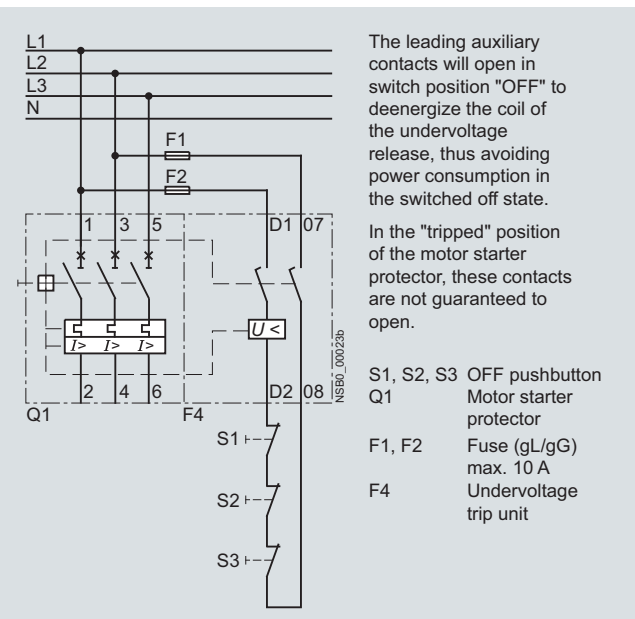

3RV Motor Starter Protectors/Circuit Breakers up to 100 A

Accessories

Rotary operating mechanisms

Overview

Door-coupling rotary operating mechanisms

Motor starter protectors with a rotary operating mechanism can be mounted in a control cabinet and operated externally by means of a door-coupling rotary operating mechanism. When the cabinet door with motor starter protector is closed, the operating mechanism is coupled. When the motor starter protector closes, the coupling is locked which prevents the door from being opened unintentionally. This interlock can be defeated by the maintenance personnel. In the Open position, the rotary operating mechanism can be secured against reclosing with up to 3 padlocks. Inadvertent opening of the door is not possible in this case either.

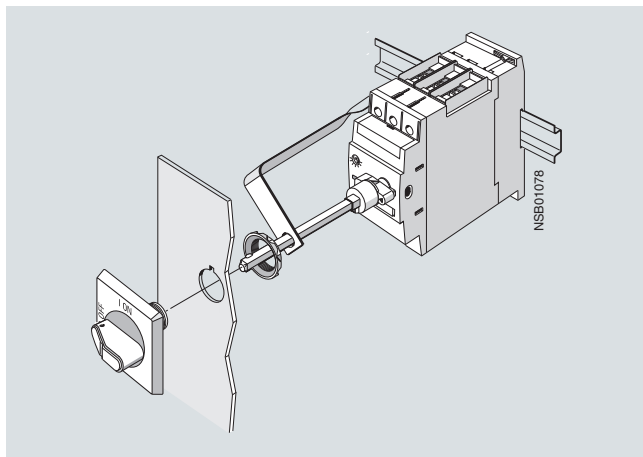

3RV19 26-0K door-coupling rotary operating mechanism

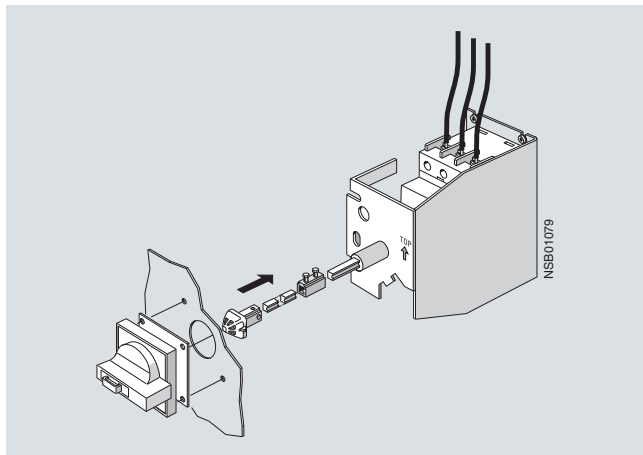

3RV29 26-2B door-coupling rotary operating mechanism for arduous conditions

Remote motorized operating mechanisms

3RV1 motor starter protectors are manually operated controls. They automatically trip in case of an overload or short-circuit. Intentional remote-controlled tripping is possible by means of a shunt trip unit or an undervoltage trip unit. Reclosing is only possible directly at the motor starter protector.

The remote motorized operating mechanism allows the motor starter protectors to be opened and closed by electrical commands. This enables a load or an installation to be isolated from the network or reconnected to it from an operator panel.

If the motor starter protector is tripped as a result of overload or short-circuit, it will be in tripped position. For reclosing, the remote motorized operating mechanism must first be set manually or electrically to the 0 position (electrically by means of the Open command). Then it can be reclosed.

The remote motorized operating mechanism is available for motor starter protectors of size S2 ($I_{n\max} = 50\text{ A}$) and S3 ($I_{n\max} = 100\text{ A}$) that are designed for control voltages of 230 V AC and 24 V DC. The motor starter protector is fitted into the remote motorized operating mechanism as shown in the drawing.

In the "MANUAL" position, the motor starter protector in the remote motorized operating mechanism can continue to be switched manually on site. In the "AUTOMATIC" position, the motor starter protector is switched by means of electrical commands. The switching command must be applied for a minimum of 100 ms. The remote motorized operating mechanism closes the motor starter protector after a maximum of 1 second. On voltage failure during the switching operation it is ensured that the motor starter protector remains in the OPEN or CLOSED position. In the "MANUAL" and "OFF" position, the remote motorized operating mechanism can be locked with a padlock.

RESET function

The RESET button on the motorized operating mechanism serves to reset any 3RV19 21-1M signal switch that might be installed.

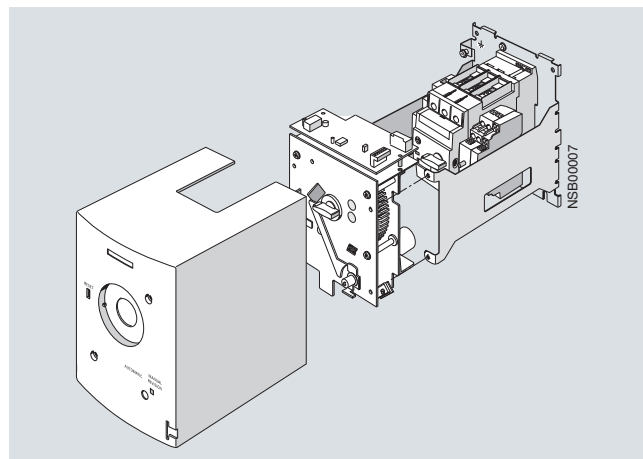

3RV19 .6-3A.. remote motorized operating mechanism

3RV Motor Starter Protectors/Circuit Breakers up to 100 A

Accessories

Rotary operating mechanisms

Technical specifications

Remote motorized operating mechanisms

Type	3RV19 36, 3RV19 46	
Max. power consumption	W	48
• At $U_s = 24$ V DC		
• At $U_s = 230$ V AC	VA	170
Operating range	0.85 ... 1.1 x U_s	
Minimum command duration at U_s	s	0.1
Max. command duration	Unlimited (uninterrupted operation)	
Max. total break time, remote-controlled	s	2
Ready to reclose after approx.	s	2.5
Switching frequency	1/h	25
Internal back-up fuse		
• 230 V AC	A	0.8
• 24 V DC	A	1.6
Connection type of control cables	Plug-in connectors with screw terminals	
Shock resistance acc. to IEC 60068-2-27	g/ms	25/11 (square and sine pulse)

Schematics

Switching examples

3RV1 motor starter protector with 3RV19 36/3RV19 46 remote motorized operating mechanisms

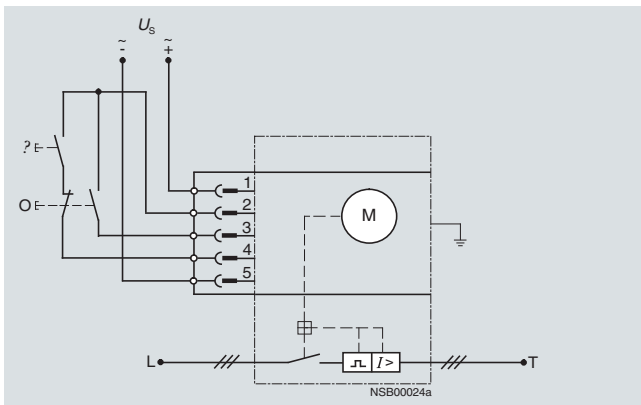

3RV Motor Starter Protectors/Circuit Breakers up to 100 A

Accessories

Mounting accessories

Overview

Solder pin connections

Solder pin terminals are available for the main contacts and transverse auxiliary switches of size S00 motor starter protectors.

The prepared terminal parts are clamped to the upper and lower screw terminals of the motor starter protectors which allows them to be soldered into printed circuit boards.

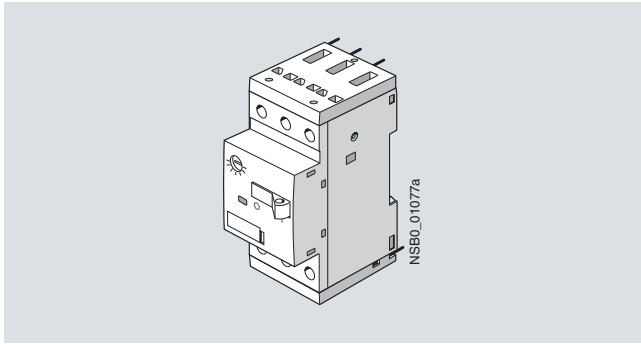

3RV19 18-5A

Terminals for "Self-Protected Combination Motor Controllers (Type E)" acc. to UL 508

The 3RV10 motor starter protectors size S0 and higher are approved according to UL 508 as "Self-Protected Combination Motor Controllers (Type E)".

This requires increased clearance and creepage distances (1 inch and 2 inches respectively) at the input side of the device, which are achieved by mounting terminal blocks.

- Size S0: The 3RV19 28-1H terminal block is simply screwed onto the basic unit.
- Size S2: The basic unit is already compliant with the new clearance and creepage distance requirements.
- Size S3: The standard box terminal must be replaced by the 3RT19 46-4GA07 terminal block.

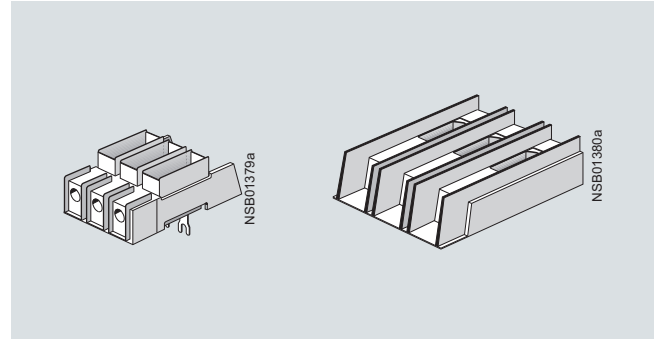



3RV19 28-1H (left), 3RT19 46-4GA07 (right)

According to CSA, these terminal blocks can be omitted when the device is used as a "Self-Protected Combination Motor Controller" (Type E).

Three-phase feeder terminals are required for constructing "Type E Starters" with an insulated busbar system (see "Busbar Accessories").

Technical specifications

Terminals for "Self-Protected Combination Motor Controllers (Type E)" acc. to UL 508

Type		3RV19 28-1H	3RT19 46-4GA07
Prescribed tightening torque	Nm	2.5 ... 3	See data for 3RV1. 4 motor starter protectors
Conductor cross-sections			
<ul style="list-style-type: none"> • Front clamping point connected <ul style="list-style-type: none"> - Solid - Finely stranded with end sleeve - Stranded - AWG cables, solid or stranded - Terminal screw 		mm ² 1 ... 10 mm ² 1 ... 16 mm ² 2.5 ... 25 mm ² 14 ... 3 M4	See data for 3RV1. 4 motor starter protectors
<ul style="list-style-type: none"> • Rear clamping point connected <ul style="list-style-type: none"> - Solid - Finely stranded with end sleeve - Stranded - AWG cables, solid or stranded - Terminal screw 		mm ² 1 ... 10 mm ² 1 ... 16 mm ² 1.5 ... 25 mm ² 16 ... 3 M4	See data for 3RV1. 4 motor starter protectors
<ul style="list-style-type: none"> • Both clamping points connected <ul style="list-style-type: none"> - Front clamping point: <ul style="list-style-type: none"> Solid Finely stranded with end sleeve Stranded AWG cables, solid or stranded Terminal screw - Rear clamping point: <ul style="list-style-type: none"> Solid Finely stranded with end sleeve Stranded AWG cables, solid or stranded Terminal screw 		mm ² 1 ... 10 mm ² 1 ... 10 mm ² 2.5 ... 10 mm ² 14 ... 6 M4 mm ² 1 ... 10 mm ² 1 ... 10 mm ² 5 ... 25 mm ² 16 ... 3 M4	See data for 3RV1. 4 motor starter protectors

3RV Motor Starter Protectors/Circuit Breakers up to 100 A Accessories

Project planning aids

Dimensional drawings

Isolator modules

3RV19 28-1A

For motor starter protector size S0

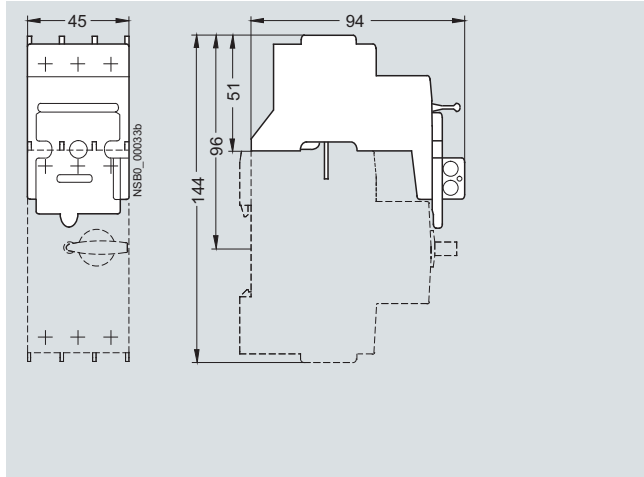

3RV19 38-1A

For motor starter protector size S2

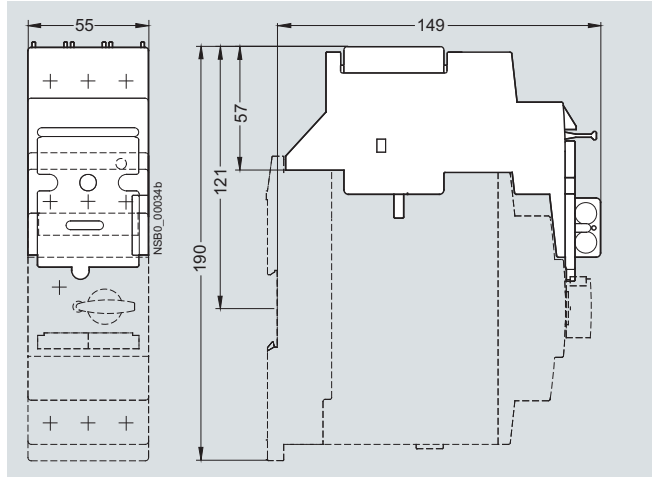

Busbars

3RV19 15-1.. 3-phase busbar

For motor starter protector sizes S00 and S0, modular spacing 45 mm

- For two 3RV19 15-1AB motor starter protectors
- For three 3RV19 15-1BB motor starter protectors
- For four 3RV19 15-1CB motor starter protectors
- For five 3RV19 15-1DB motor starter protectors

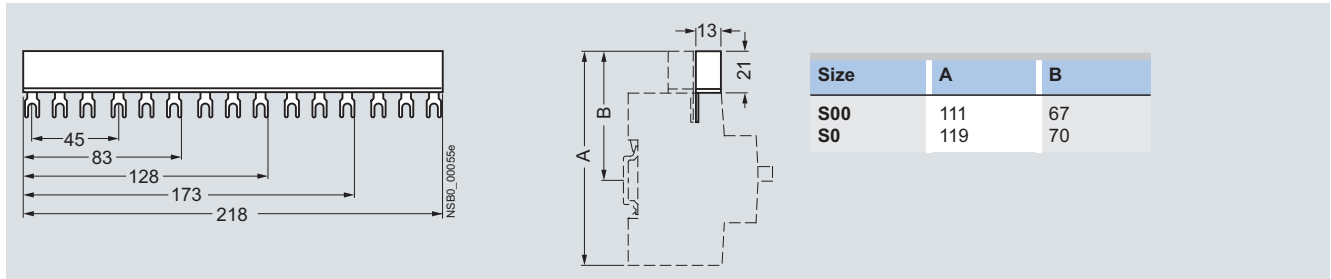

3RV19 15-2.. 3-phase busbar

For motor starter protector sizes S00 and S0, modular spacing 55 mm

- For two 3RV19 15-2AB motor starter protectors with accessory
- For three 3RV19 15-2BB motor starter protectors with accessory
- For four 3RV19 15-2CB motor starter protectors with accessory
- For five 3RV19 15-2DB motor starter protectors with accessory

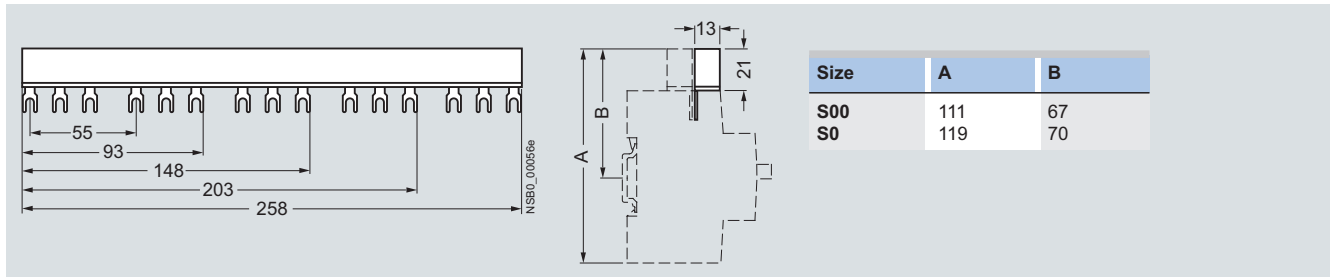

3RV Motor Starter Protectors/Circuit Breakers up to 100 A

Accessories

Project planning aids

3RV19 15-3.. 3-phase busbar

For motor starter protector sizes S00 and S0, modular spacing 63 mm
 For two 3RV19 15-3AB motor starter protectors with accessory
 For four 3RV19 15-3CB motor starter protectors with accessory

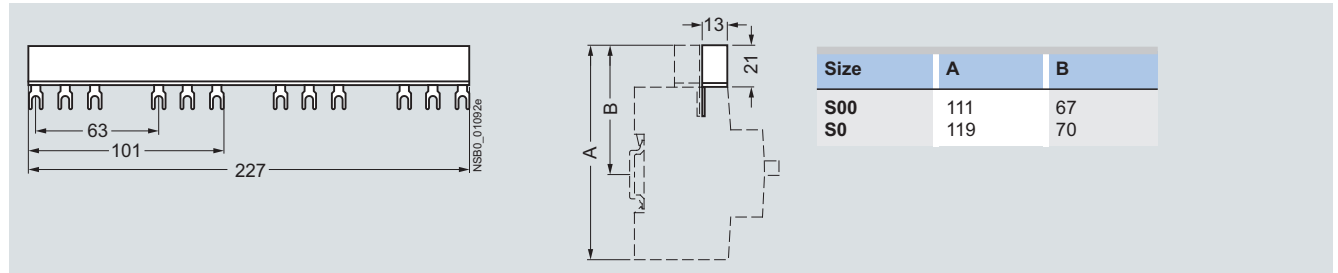

3RV19 35-1.. 3-phase busbar

For motor starter protector size S2, modular spacing 55 mm
 For two 3RV19 35-1A motor starter protectors
 For three 3RV19 35-1B motor starter protectors
 For four 3RV19 35-1C motor starter protectors

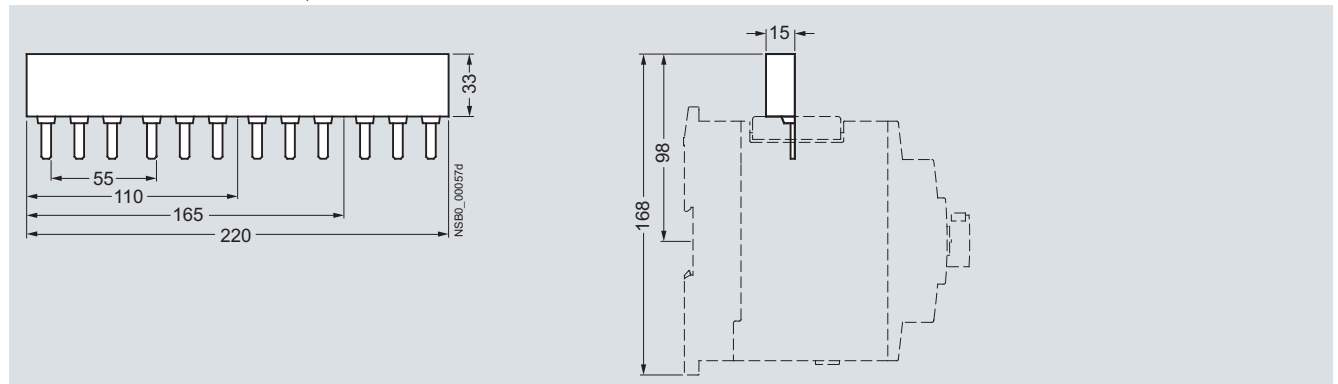

3RV19 35-3.. 3-phase busbar

For motor starter protector size S2, modular spacing 75 mm
 For two 3RV19 35-3A motor starter protectors with accessory
 For three 3RV19 35-3B motor starter protectors with accessory
 For four 3RV19 35-3C motor starter protectors with accessory

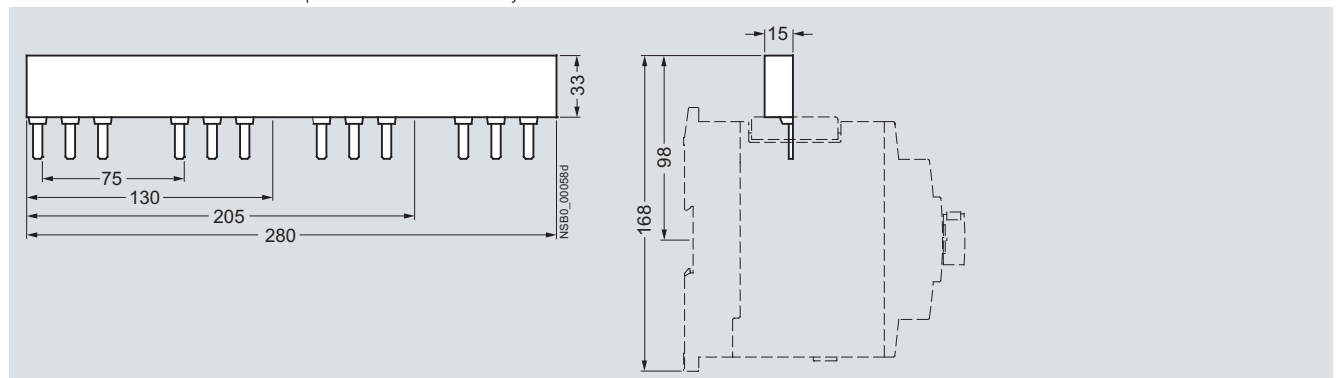

3RV19 15-5DB connecting piece

For connecting 3-phase busbars for motor starter protector size S0 (left) to size S00 (right)

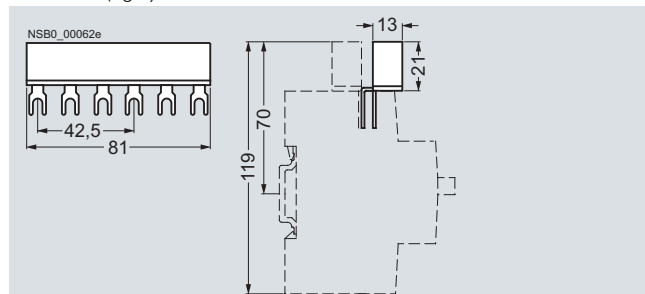

3RV Motor Starter Protectors/Circuit Breakers up to 100 A Accessories

Project planning aids

3RV19 .5 three-phase feeder terminals

3RV19 15-5A
Connected from top,
for motor starter protector size S00

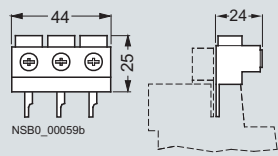

3RV19 25-5AB
Connected from top,
for motor starter protector size S0

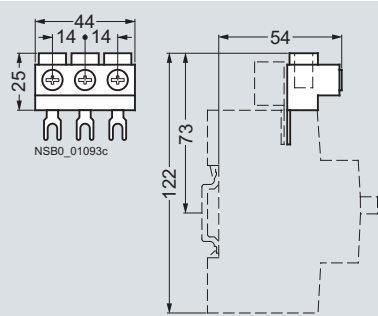

3RV19 25-5EB to construct "Type E Starters"
Connected from top,
for motor starter protector size S0

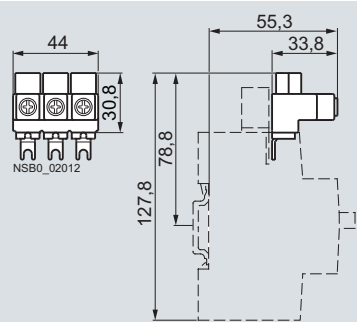

3RV19 35-5B
Connected from bottom,
for motor starter protector size S00 and S0

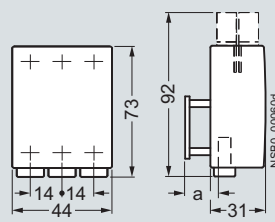

Typ	a
3RV1. 1	19
3RV1. 2	23

3RV19 35-5A
Connected from top,
for motor starter protector size S2

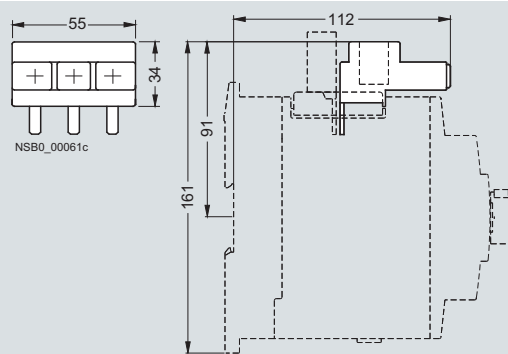

3RV19 35-5E
Connected from top,
for motor starter protector size S2

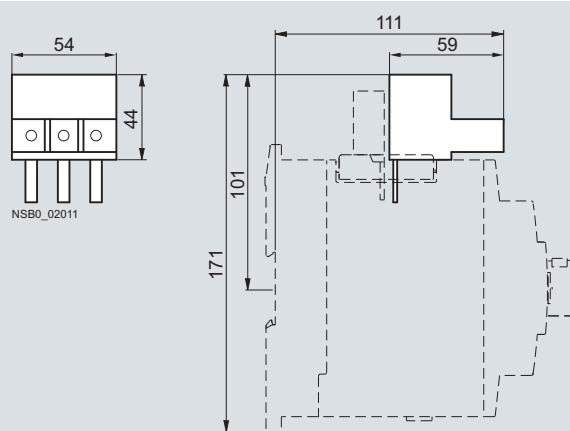

3RV Motor Starter Protectors/Circuit Breakers up to 100 A

Accessories

Project planning aids

3RV19 26-0. door-coupling rotary operating mechanisms

3RV19 26-0B, 3RV19 26-0C

Short shaft³⁾, for motor starter protector sizes S0, S2, S3

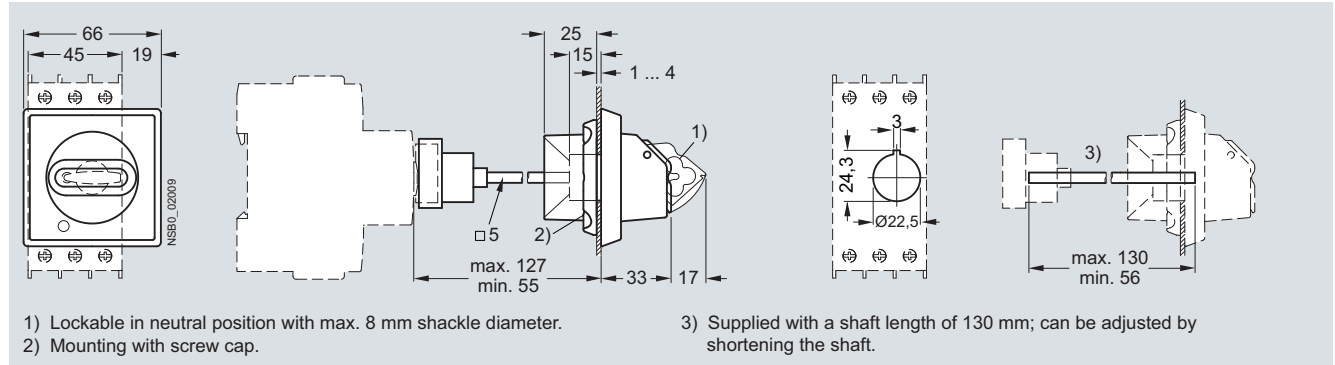

- 1) Lockable in neutral position with max. 8 mm shackle diameter.
- 2) Mounting with screw cap.
- 3) Supplied with a shaft length of 130 mm; can be adjusted by shortening the shaft.

3RV19 26-0K, 3RV19 26-0L

Long shaft (with bracket)³⁾, for motor starter protector sizes S0, S2, S3

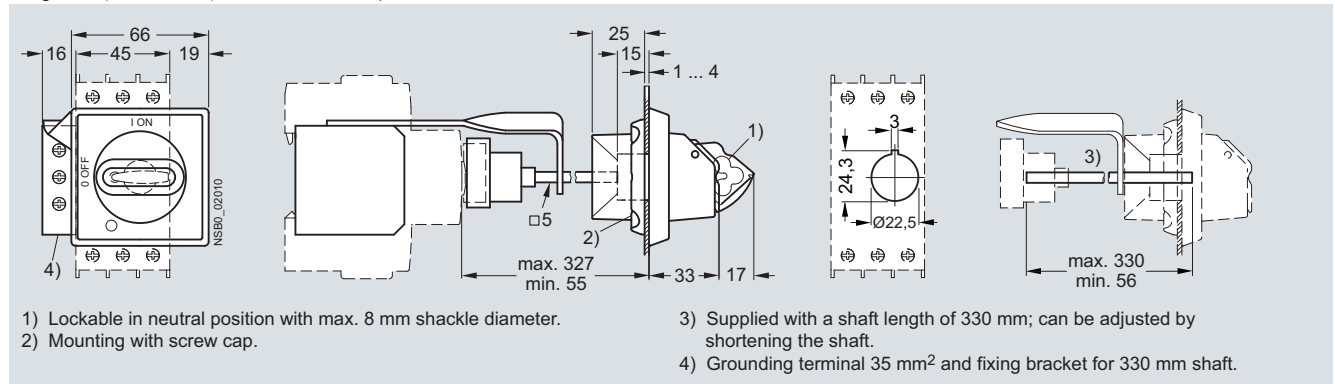

- 1) Lockable in neutral position with max. 8 mm shackle diameter.
- 2) Mounting with screw cap.
- 3) Supplied with a shaft length of 330 mm; can be adjusted by shortening the shaft.
- 4) Grounding terminal 35 mm² and fixing bracket for 330 mm shaft.

3RV29 .6-2. door-coupling rotary operating mechanisms for arduous conditions

3RV29 26-2., 3RV29 36-2., 3RV29 46-2.

For motor starter protector size S0, S2 and S3

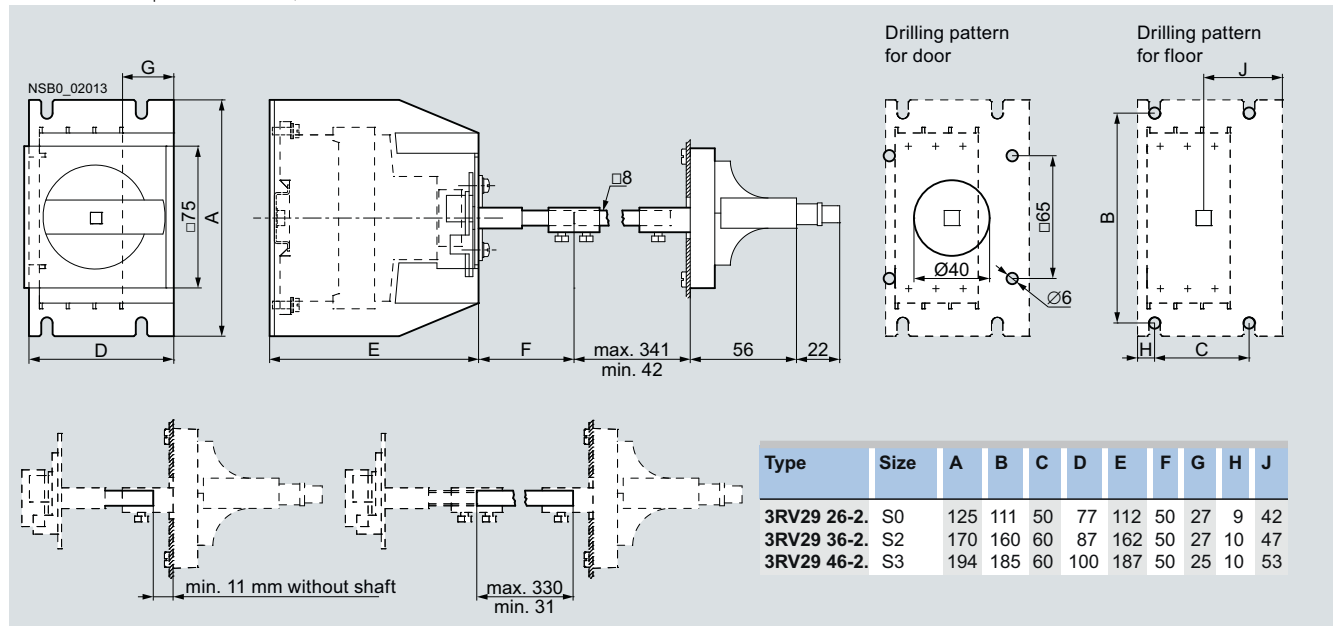

Type	Size	A	B	C	D	E	F	G	H	J
3RV29 26-2.	S0	125	111	50	77	112	50	27	9	42
3RV29 36-2.	S2	170	160	60	87	162	50	27	10	47
3RV29 46-2.	S3	194	185	60	100	187	50	25	10	53

3RV Motor Starter Protectors/Circuit Breakers up to 100 A

Accessories

Project planning aids

Remote motorized operating mechanisms

3RV19. 6-3A..

For motor starter protector size S2 and S3

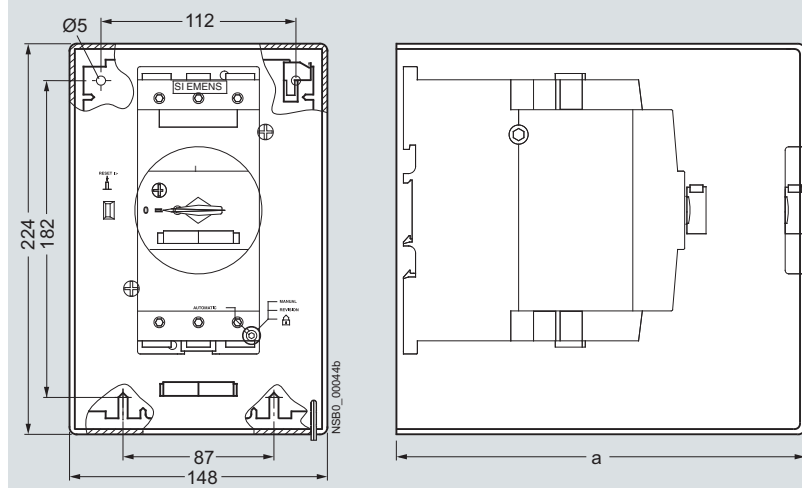

Type	a
3RV19 36-3AP0, 3RV19 36-3AB4	211
3RV19 46-3AP0, 3RV19 49-3AB4	236

3RV19 18-5. solder pin connections

3RV19 18-5A, 3RV19 18-5B

For motor starter protector size S00

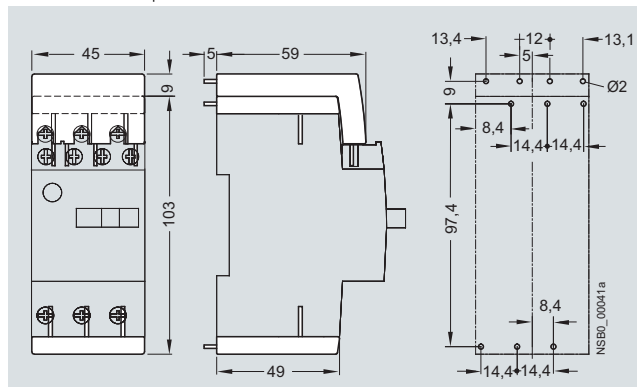

Terminals for "Self-Protected Combination Motor Controllers (Type E)" acc. to UL 508

3RV19 28-1H

For motor starter protector size S0

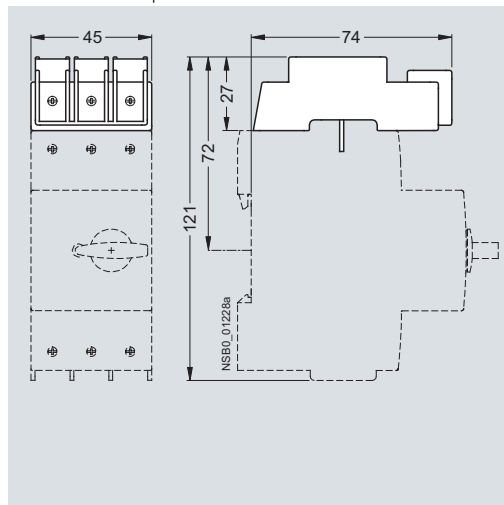

3RT19 46-4GA07

For motor starter protector size S3

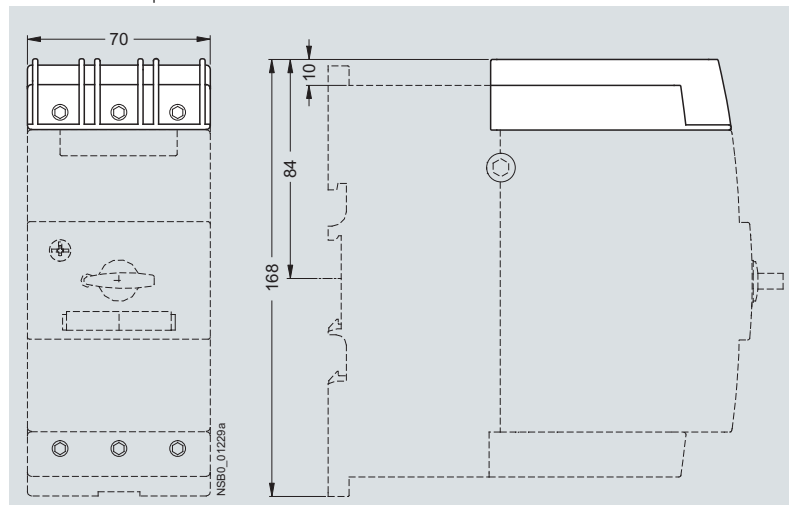

3RV Motor Starter Protectors/Circuit Breakers up to 100 A

Accessories

Project planning aids

3RV19 .3-1.A00 molded-plastic enclosures for surface mounting

3RV19 13-1.A00

For motor starter protector size S00

1) Knock-outs for M25 cable glands.
 2) Knock-outs for rear cable entry M20.
 3) With safety lock.
 4) Max. shackle diameter for padlock 8 mm.
 5) 3RV19 03-5 indicator light.
 6) 3RV19 13-6B locking device.
 7) 3RV19 13-7 EMERGENCY-STOP mushroom button.

a) 3RV19 13-1CA00: 85 mm,
 3RV19 13-1DA00: 105 mm.
 b) With EMERGENCY-STOP mushroom button:
 - 3RV19 13-7D: 153 mm,
 - 3RV19 13-7E: 173 mm.
 Dimensions refer to mounting surface.
 b) With EMERGENCY-STOP mushroom button:
 - 3RV19 13-7D: 64 mm,
 - 3RV19 13-7E: 84 mm.
 d) Dimensions refer to mounting surface.

3RV19 23-1.A00

For motor starter protector size S0

Type	a
3RV19 23-1CA00	85
3RV19 23-1DA00	105

- 1) Knock-outs for M25 cable glands.
- 2) Knock-outs for rear cable entry M20.
- 3) Opening for padlock with shackle diameter max. 6 mm ... 8 mm.
- 4) 3RV19 03-5 indicator light.

3RV19 33-1.A00

For motor starter protector size S2

- 1) Knock-outs for M32 (left) and M40 (right).
- 2) Knock-outs for rear cable entry M32.
- 3) Opening for padlock with shackle diameter max. 6 mm ... 8 mm.
- 4) Indicator light 3RV19 03-5.

3RV Motor Starter Protectors/Circuit Breakers up to 100 A Accessories

Project planning aids

3RV19 23-1.A01 cast aluminum enclosures for surface mounting

3RV19 23-1DA01, 3RV19 23-1GA01

For motor starter protector size S0

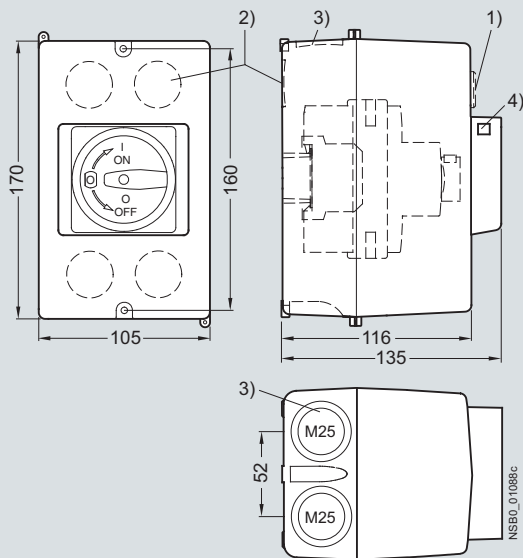

- 1) 3RV19 03-5 indicator light.
- 2) Knock-outs for rear cable entry M20.
- 3) Knock-outs for M25 cable glands.
- 4) Opening for padlock with shackle diameter from 6 mm ... 8 mm.

3RV19 13-2DA00 molded-plastic enclosures for flush mounting

3RV19 13-2DA00

For motor starter protector size S00

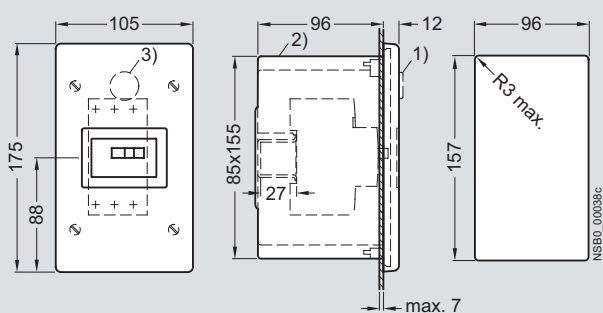

- 1) 3RV19 03-5 indicator light.
- 2) Knock-outs for M25 cable glands.
- 3) Knock-outs for rear cable entry M20.

3RV19 13-4C molded-plastic front plates

3RV19 13-4C

For motor starter protector size S00

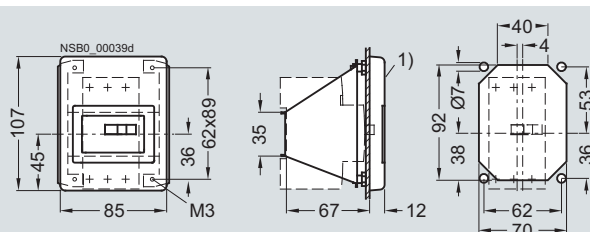

- 1) 3RV19 03-5 indicator light.

3RV19 23-2.A00 molded-plastic enclosures for flush mounting

3RV19 23-2DA00, 3RV19 23-2GA00

For motor starter protector size S0

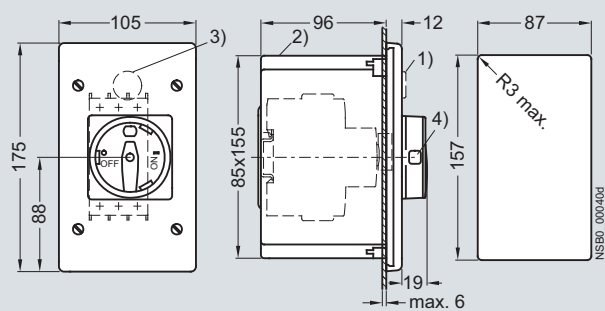

- 1) 3RV19 03-5 indicator light.
- 2) Knock-outs for M25 cable glands.
- 3) Knock-outs for rear cable entry M20.
- 4) Opening for padlock with shackle diameter from 6 mm ... 8 mm.

3RV19 23-4. molded-plastic front plates

3RV19 23-4B, 3RV19 23-4E

For motor starter protector sizes S0, S2, S3;

3RV19 23-4G holders

Only for motor starter protectors size S0

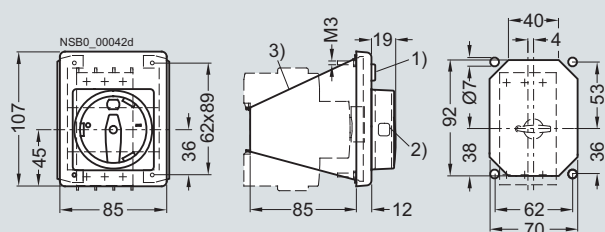

- 1) 3RV19 03-5 indicator light.
- 2) Opening for padlock with shackle diameter from 6 mm ... 8 mm.
- 3) 3RV19 23-4G holder.

3RV Molded Case Motor Starter Protectors up to 800 A

General data

Overview



3RV10 63-7AL10 molded case motor starter protector

The 3RV10 and 3RV13 molded case motor starter protectors for up to 800 A are compact, current-limiting motor starter protectors which can be used above all in load feeders for special voltages of 440 V, 480 V, 550 V and 690 V. They are used for switching and protecting induction motors and other loads with rated currents up to 800 A.

Type of construction

The molded case motor starter protectors are available in 4 widths:

- 3RV13 53 – width 90 mm, max. rated current 32 A, at 400 V AC suitable for induction motors up to 22 kW.
- 3RV1. 6. – width 105 mm, max. rated current 250 A, at 400 V AC suitable for induction motors up to 110 kW.
- 3RV1. 7. – width 140 mm, max. rated current 630 A, at 400 V AC suitable for induction motors up to 200 kW.
- 3RV1. 83 – width 210 mm, max. rated current 800 A, at 400 V AC suitable for induction motors up to 355 kW.

The 3RV1 molded case motor starter protectors for up to 800 A can be mounted in horizontal, vertical or lying arrangement directly on a mounting plate or mounting rail. Their rated data are adversely affected as the result.

The phase barriers for better insulation between the phases are included in the scope of supply.

The motor starter protectors can be supplied through top and bottom terminals without impairing their function, enabling them to be installed in any type of switchgear without any further steps.

3RV Molded Case Motor Starter Protectors up to 800 A

General data

Design

Installation guidelines for 3RV1 molded case motor starter protectors

Installation clearances

When mounting the molded case motor starter protectors, the following clearances must be maintained to grounded or live parts and to cable ducts made of molded plastic.

Molded case motor starter protectors		Mandatory distances		
Type	Rated operational voltage U_e V	A mm	B mm	C mm
3RV13 53	Up to 690	25	20	20
3RV1. 6.	Up to 400 440 ... 690	30 100	25	25
3RV1. 7.	Up to 400 440 ... 690	30 100	25	25
3RV1. 83	Up to 690	100	25	20

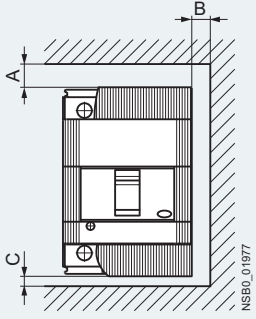

Minimum distance between two molded case motor starter protectors installed alongside or on top of each other

When molded case motor starter protectors are installed alongside or on top of each other it is important to make sure that neither the busbars nor connection cables reduce the clearance.

Minimum distance between two molded case motor starter protectors installed alongside each other

Molded case motor starter protectors			Mandatory distances
Type	Rated operational voltage U_e V	Width mm	Minimum distance between axes I mm
3RV13 53	Up to 690	90	90
3RV1. 6.	Up to 690	105	105
3RV1. 7.	Up to 440 500 ... 690	140	140 180
3RV1. 83	Up to 690	210	210

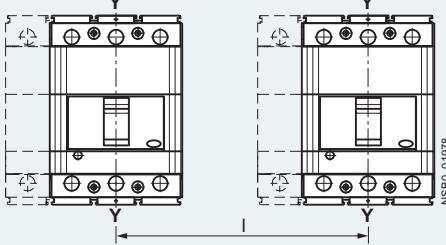

Minimum distance between two molded case motor starter protectors installed on top of each other

Molded case motor starter protectors		Mandatory distances
Type	Rated operational voltage U_e V	Minimum distance between axes H mm
3RV13 53	Up to 690	90
3RV1. 6.	Up to 690	160
3RV1. 7.	Up to 690	160
3RV1. 83	Up to 690	180

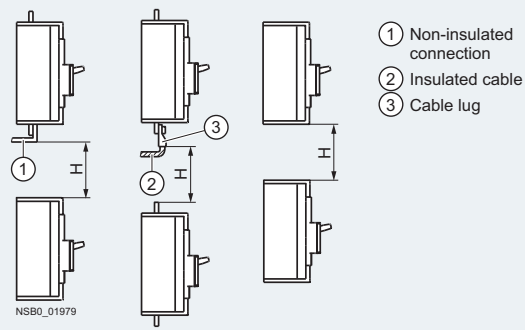

Note:

The quoted voltages apply for operational voltages U_b up to 690 V. The mandatory distances must be added to the maximum dimensions of the molded case motor starter protectors in their various versions, including terminals.

3RV Molded Case Motor Starter Protectors up to 800 A

General data

Function

Trip units

The 3RV1 molded case motor starter protectors for up to 800 A are available with four different trip units.

Type ¹⁾	Tripping method	For molded case motor starter protectors	Function	Setting range	External overload relay required for overload protection
TU 1	Purely magnetic	1 ... 12.5 A	Short-circuit protection	Non-adjustable: $13 \times I_N$	Yes
TU 2	Purely magnetic	20 A, 32 A	Short-circuit protection	Adjustable: $6 \dots 13 \times I_N$	Yes
TU 3	Electronic (for starter combinations)	100 ... 800 A	Short-circuit protection	Adjustable: $1 \dots 10 \times I_N$	Yes
TU 4	Electronic (for motor protection)	100 ... 630 A	Overload protection Short-circuit protection Protection in the event of rotor blockage	Adjustable: $I_1 = 0.4 \dots 1 \times I_N$ $6 \dots 13 \times I_N$ $3 \dots 10 \times I_1$	No

¹⁾ TU = Trip unit

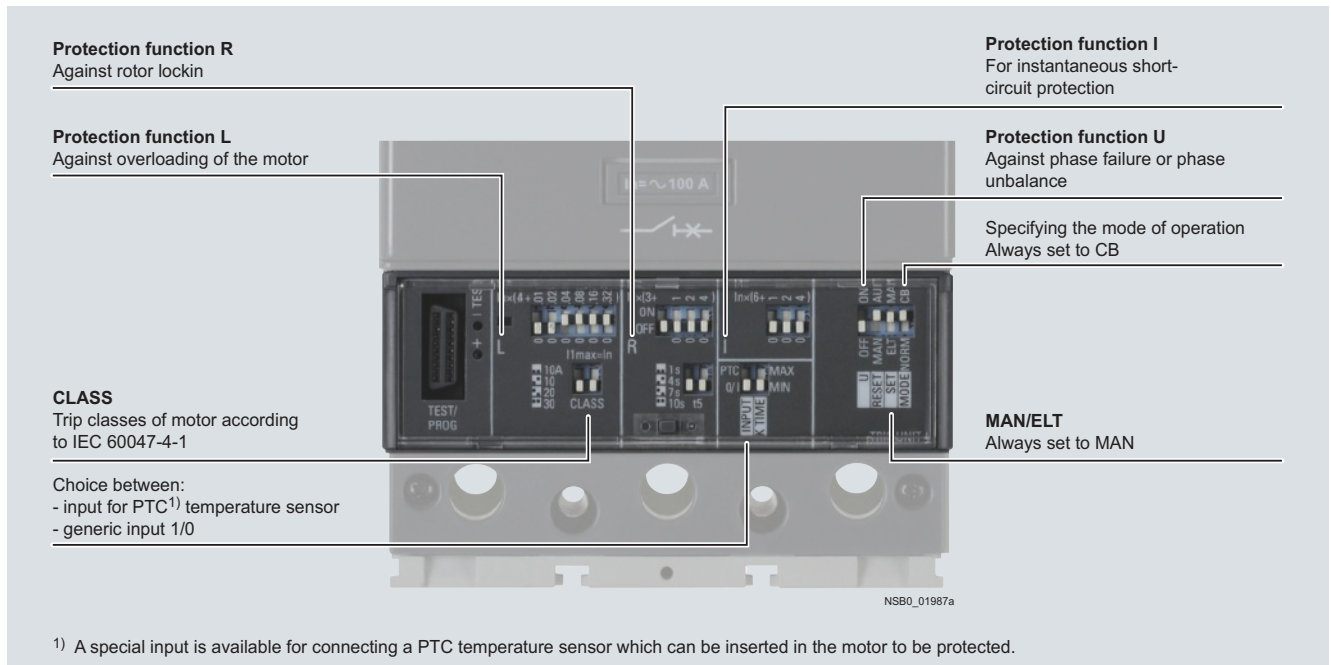

3RV10 molded case motor starter protectors with trip unit TU 4

Trip classes

The trip classes of thermally delayed trip units are based on the tripping time (t_A) at 7.2 times the set current in cold state (excerpt from IEC 60947-4):

- CLASS 10A: $2 \text{ s} < t_A < 10 \text{ s}$
- CLASS 10: $4 \text{ s} < t_A < 10 \text{ s}$
- CLASS 20: $6 \text{ s} < t_A < 20 \text{ s}$
- CLASS 30: $9 \text{ s} < t_A < 30 \text{ s}$

The molded case motor starter protector must trip within this time!

With the 3RV1 molded case motor starter protectors (100 A to 630 A) which are equipped with the TU 4 trip unit, all four trip classes are possible.

Safe switch position

The toggle lever indicates tripping by adopting the "Tripped" position. To prevent switching onto an existing fault, the lever must be moved by hand to the 0 position prior to switching on again. Only then can the molded case motor starter protector be switched on again.

Configuration

The 3RV1 molded case motor starter protectors for up to 800 A are optimally coordinated and tested for combinations with 3RT contactors and, in starter combinations, with Sirius 3RU/3RB overload relays and SIMOCODE 3UF7. Detailed assignment tables for the special voltages 440 V, 480 V, 550 V and 690 V are included in the brochure "SIRIUS Configuration".

Prevention of unintended tripping

In order to prevent unwanted tripping of the molded case motor starter protectors, they should always be connected such that current flows through all 3 main current paths.

Short-circuit protection

If a short-circuit occurs, the short-circuit releases of the 3RV1 molded case motor starter protectors isolate the faulty load feeder from the network and thus prevent further damage.

Motor starter protectors with a short-circuit breaking capacity of 50 kA or 100 kA are virtually short-circuit resistant at a voltage of 400 V AC, since higher short-circuit currents are not to be expected in practice.

Motor protection

The tripping characteristics of the 3RV10 molded case motor starter protectors are designed mainly to protect induction motors.

The motor starter protectors are therefore also referred to as motor-protective circuit breakers.

Short-circuit protection for starter combinations

The 3RV13 molded case motor starter protectors for starter combinations provide short-circuit protection for combinations of a contactor and overload relay.

- On overload, the overload relay triggers the contactor, the motor starter protector remains closed.
- Only when a short-circuit occurs in the feeder does the motor starter protector trip as well.

The molded case motor starter protectors for starter combinations must always be used in combination with an overload relay because the motor starter protector alone cannot protect the motor and itself against overload.

Altitude

The molded case motor starter protectors can be used without restriction at altitudes up to 2000 meters. At higher altitudes it is important to take account of the amended characteristics of the motor starter protector according to the following table.

Altitude	Max. rated operational voltage U_e	Max. rated operational current I_e
m	V AC	in % of I_n
2000	690	100
3000	600	96
4000	500	93
5000	440	90

Temperature characteristic

At higher temperatures it is necessary to take account of a reduction in the maximum permissible rated uninterrupted current (derating).

The maximum rated operational currents for the different 3RV1 molded case motor starter protectors are listed in the following table. These permissible loads apply for the molded case motor starter protectors with standard terminals, with front-extended terminals (see "Accessories") and with front-extended cable terminals (see "Accessories").

Molded case motor starter protectors	Max. rated current I_e	Max. rated operational current I_e at					
		45 °C	50 °C	55 °C	60 °C	65 °C	70 °C
	A	A	A	A	A	A	A
3RV1. 5	32	32	32	32	32	32	32
3RV1. 6	250	250	250	250	250	230	220
3RV1. 7	400	400	400	400	400	376	352
	630	630	580	552	530	504	479
3RV1. 8	630	630	630	565	598	583	567
	800	800	800	780	760	740	720

If required, derating values for rear-accessible terminals (see "Accessories") can be obtained from "Technical Assistance":

- Either by e-mail to: technical-assistance@siemens.com
- Or on the Internet: <http://www.siemens.com/automation/service&support>

3RV Molded Case Motor Starter Protectors up to 800 A

General data

Technical specifications

General technical specifications

Type		3RV10 63	3RV10 73	3RV10 83	3RV13 53	3RV13 63	3RV13 64	3RV13 73	3RV13 74	3RV13 83		
Standard		IEC 60947-2, EN 60947-2										
Motor protection		3			--							
Starter combinations		--			3							
Rated current I_n	A	160	400	630	160	250		400, 630		630, 800		
Number of poles		3										
Rated operational voltage U_e AC 50 ... 60 Hz	V	690										
Rated impulse withstand voltage U_{imp}	V	8										
Rated insulation voltage U_i	V	1 000			800	1 000						
Test voltage at industrial frequency for 1 min	V	3 500			3 000	3 500						
Rated ultimate short-circuit breaking capacity I_{cu}												
• At 220/230 V AC, 50 ... 60 Hz	kA	200			120	200						
• At 380/415 V AC, 50 ... 60 Hz	kA	120		100	85	120	200	120	200	100		
• At 440 V AC, 50 ... 60 Hz	kA	100		80	75	100	180	100	180	80		
• At 500 V AC, 50 ... 60 Hz	kA	85		65	50	85	150	85	150	65		
• At 550 V AC, 50 ... 60 Hz	kA	--			35	--						
• At 690 V AC, 50 ... 60 Hz	kA	70		30	10	70	80	70	80	30		
Rated short-circuit breaking capacity I_{cs} (% of I_{cu})												
• At 220/230 V AC, 50 ... 60 Hz	%	100		75	100						75	
• At 380/415 V AC, 50 ... 60 Hz	%	100		75	100						75	
• At 440 V AC, 50 ... 60 Hz	%	100		75	100						75	
• At 500 V AC, 50 ... 60 Hz	%	100		75	100					$100^{1)}/75^{2)}$	100	75
• At 690 V AC, 50 ... 60 Hz	%	100		75	100					$100^{1)}/50^{2)}$	100	75
Rated short-circuit making capacity (415 V)	kA	264		220	187	264	440	264	440	220		
Break time (415 V at I_{cu})	ms	5		6	7	3	5	6		7		
Category (EN 60947-2)		A		B (400 A), A (630 A)	B	A		B (400 A), A (630 A)		B		
Isolating features		✓										
Trip classes CLASS		10A, 10, 20, 30			--							
Trip units												
• Magnetic-type		--			✓	--						
• Electronic (motor protection)		3			... ³⁾							
• Electronic (starter combinations)		--			✓							
Permissible ambient temperature												
• Operation	°C	-25 ... +70 ⁴⁾										
• Storage	°C	-40 ... +70										
Mechanical endurance												
• Operating cycles		20 000			25 000	20 000						
• Operating cycles per hour		240	120		240					120		
Electrical endurance												
• Operating cycles		8 000	7 000	5 000	8 000				7 000	5 000		
• Operating cycles per hour (415 V AC)		120	60		120					60		

1) Value applies for 3RV13 73-7GN10 molded case motor starter protectors.

2) Value applies for 3RV13 73-7JN10 molded case motor starter protectors.

3) For overload protection of the motors, appropriate overload relays must be used.

4) From 50 °C derating must be observed in some cases, see table in page 5/43.

3RV Molded Case Motor Starter Protectors up to 800 A

General data

Main circuit terminals

Type	3RV13 53	3RV1. 6.	3RV1. 7.	3RV10 83-7JL10, 3RV13 83-7KN10 3RV13 83-7JN10
------	----------	----------	----------	--

Terminal dimensions

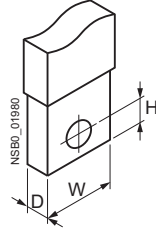

Front-accessible standard terminals

Busbars/cable lug

Number	Units	11	2			
Dimensions						
• W	mm	20	25	35	40	50
• D	mm	5	8	10	5	
• H	mm	7.5	9.5	11	12	
• Hole diameter	mm	6.5	8.5	10.5	7	

Front-extended terminals

Busbars

Number	Units	1	2			
Dimensions						
• W	mm	20		30	40	50
• D	mm	4	10	7	5	5
• Hole diameter	mm	8.5	10	11		14

Cable lug

Number	Units	1	2			
Dimensions						
• B	mm	20		30	40	50
• Hole diameter	mm	8.5	10	11		14

Front-extended cable terminals for copper cable

Busbars, flexible

Number	Units	1	--			
Dimensions W x D x N						
• W	mm	13	15.5	24	--	--
• D	mm	0.5	0.8	1	--	--
• N (= number of laminations)	mm	10			--	--

Cable lug, flexible

Number	Units	1 or 2	--			
Dimensions						
• For 1 unit	mm ²	1 ... 70	2.5 ... 120	16 ... 240	--	--
• For 2 units	mm ²	1 ... 50	2.5 ... 95	16 ... 150	--	--

Cable lug, rigid

Number	Units	1	1 or 2		--	
Dimensions						
• For 1 unit	mm ²	1 ... 95	2.5 ... 185	16 ... 300	--	--
• For 2 units (for outside mounting)	mm ²	--		120 ... 240	--	--

Rear-mounting terminals

Busbars

Number	Units	1	2			
Dimensions						
• W	mm	20		30	40	50
• D	mm	4	10	7	5	
• Hole diameter	mm	8.5		11	14	

3RV Molded Case Motor Starter Protectors up to 800 A

General data

Characteristic curves

Example characteristic of a 3RV10 molded case motor starter protector with electronic trip unit for motor protection (TU 4)

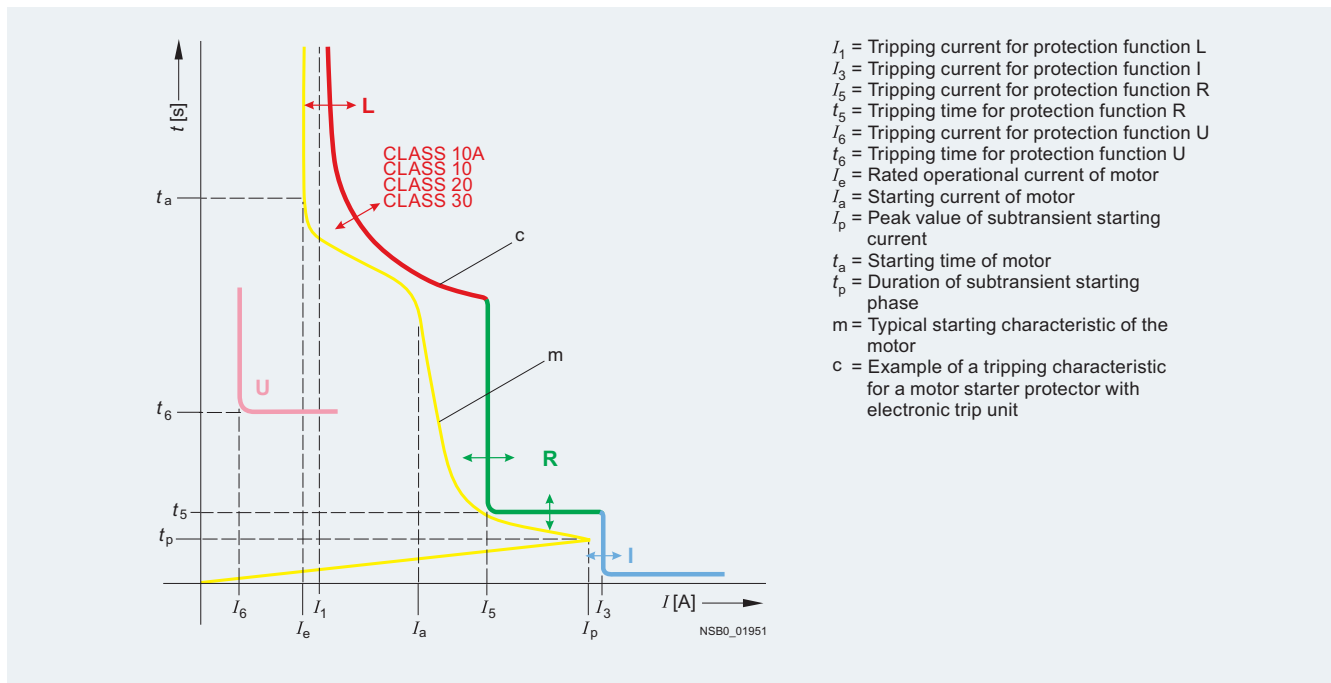

TU = trip unit

Protection from overload (L trip unit)

The L protection-function protects the motor from overload and is temperature-compensated according to IEC 60947-4-1 and sensitive to phase failure and phase unbalance. With the DIP switches on the trip unit the function can be set by hand to between 0.4 and 1 times the rated current. The trip class can also be set here.

A pre-alarm LED and an alarm LED indicate violation of the pre-alarm threshold (0.9 times the tripping current) and the alarm threshold (1.05 times the tripping current).

Protection from short-circuits (I trip unit)

This function protects the motor from short-circuits between two phases. It always responds when a phase exceeds the set tripping value (6 to 12 times the rated current). Safe start-up is guaranteed.

Protection in the event of rotor blockage (R trip unit), can be switched off

With this function the motor is protected in the event of rotor blockage during operation. During motor start-up, this function is blocked for the time defined by the trip class. Thereafter the trip unit trips after 1 to 10 s at 3 to 10 times the tripping current for the overload (each can be set by means of DIP switches).

Protection in the event of phase failure or phase unbalance (U trip unit), can be switched off

This function protects the motor when it is important to check in particular for phase failure and phase unbalance. The function responds when the rms value of the current in one or two phases remains 4 seconds long below the limit threshold of 0.4 times the tripping current for the overload.

Time/current characteristic curves, current limiting characteristic curves and I^2t curves can be ordered from "Technical Assistance":

- Either by e-mail to: technical-assistance@siemens.com
- Or on the Internet: <http://www.siemens.com/automation/service&support>

3RV Molded Case Motor Starter Protectors up to 800 A

General data

Dimensional drawings

*3RV10 molded case motor starter protectors for motor protection,
3RV13 molded case motor starter protectors for starter combinations*

3RV13 53

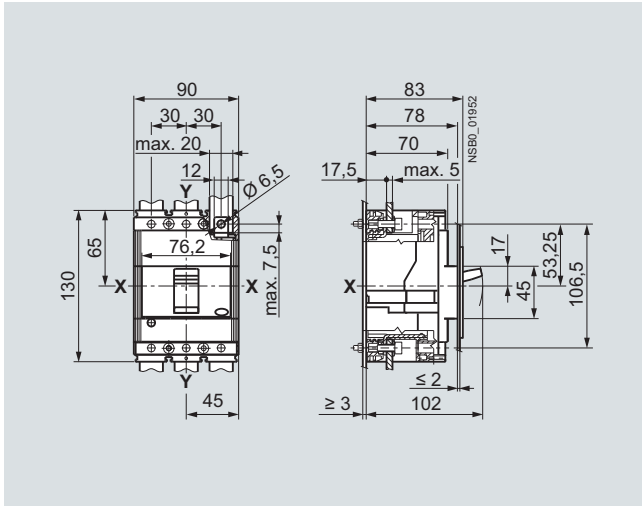

3RV10 63, 3RV13 6.

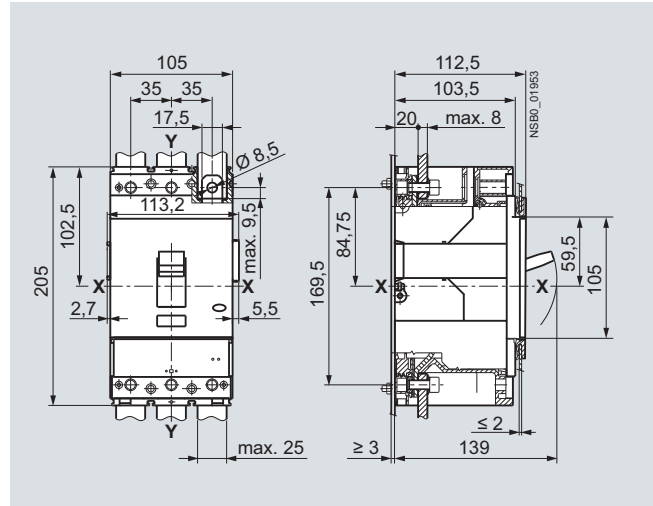

3RV10 73, 3RV13 7.

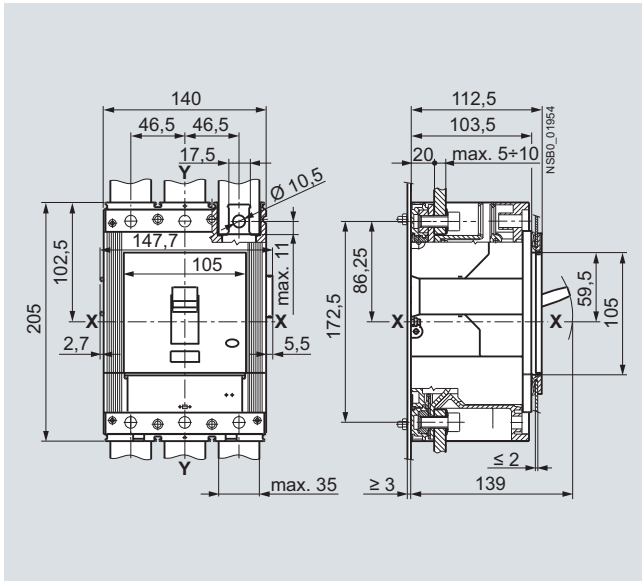

3RV10 83, 3RV13 83

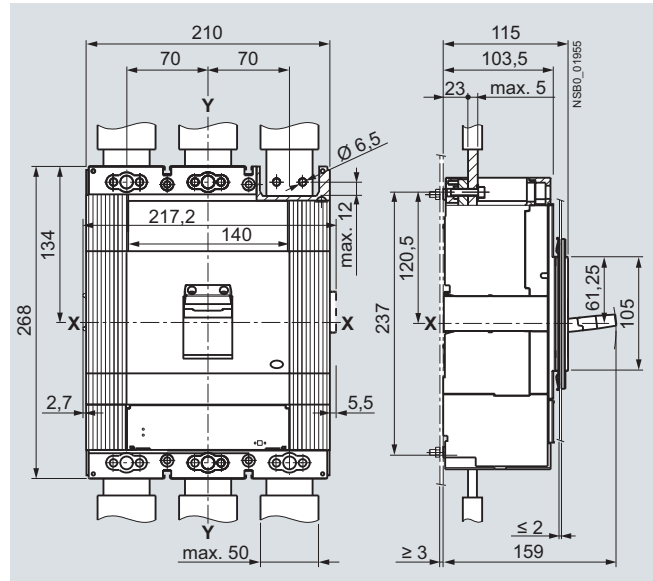

3RV Molded Case Motor Starter Protectors up to 800 A

General data

Schematics

Internal circuit diagrams

Molded case motor starter protectors with electronic trip unit

3RV13 53

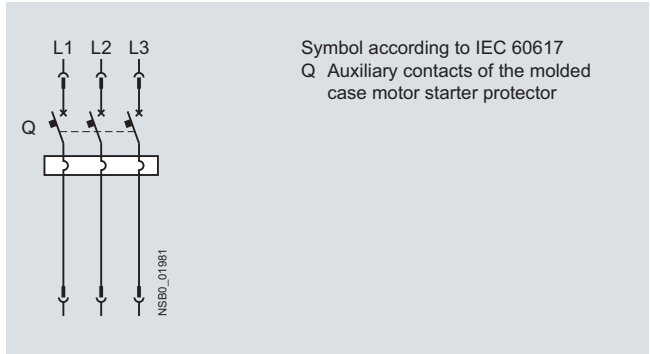

Molded case motor starter protectors with electronic trip unit

TU 3: 3RV13 63, 3RV13 64, 3RV13 73, 3RV13 74, 3RV13 83

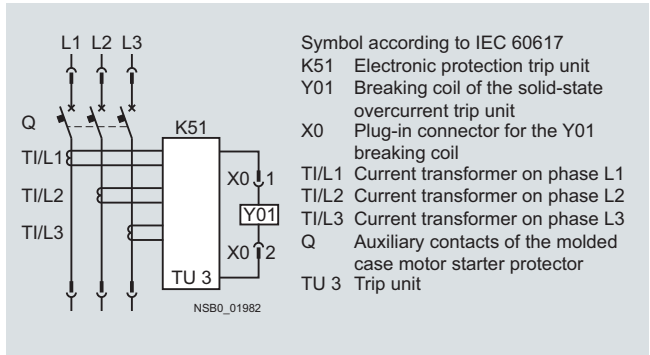

TU 4: 3RV10 63, 3RV10 73, 3RV10 83

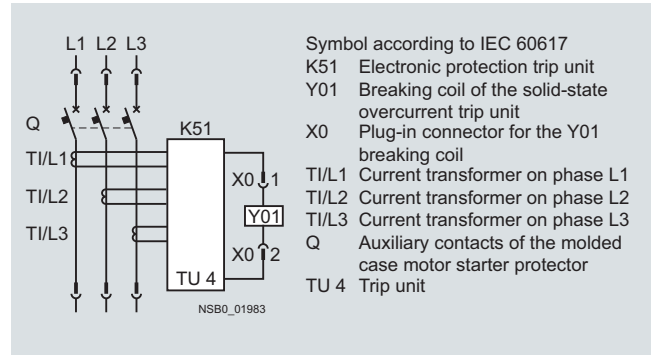

5

3RV Molded Case Motor Starter Protectors up to 800 A Accessories

Mountable accessories

Technical specifications

Auxiliary switches

Type	3RV19 91-1.A0	
Rated operational current I_e		
• At 250 V AC/DC		
- At AC-14 (utilization category acc. to IEC 60947-5-1)		
Supply voltage 125 V	A	6
Supply voltage 250 V	A	5
- At DC-14 (utilization category acc. to IEC 60947-5-1)		
Supply voltage 125 V	A	0.3
Supply voltage 250 V	A	0.15
• At 24 V DC		
- Supply voltage 24 V	mA	≥ 0.75
- Supply voltage 5 V	mA	≥ 1

Auxiliary trip units

Molded case motor starter protectors	Power consumption during pick-up			
	3RV13 53		3RV1. 6, 3RV1. 7, 3RV1. 83	
Version	AC	DC	AC	DC
Undervoltage trip units				
• 24 ... 30 V AC/DC	1.5 VA	1.5 W	6 VA	150 W
• 110 ... 127 V AC/110 ... 125 V DC	2 VA	2 W	6 VA	150 W
• 220 ... 240 V AC/220 ... 250 V DC	2.5 VA	2.5 W	6 VA	150 W
Opening times	ms	15	≤ 25	≤ 15
Shunt trip units				
• 24 ... 30 V AC/DC	50 VA	50 W	150 VA	150 W
• 110 ... 127 V AC/110 ... 125 V DC	50 VA	50 W	150 VA	150 W
• 220 ... 240 V AC/220 ... 250 V DC	50 VA	50 W	150 VA	150 W
Opening times	ms	15	15	15

Schematics

Internal circuit diagrams

Auxiliary switches

3RV19 91-1AA0

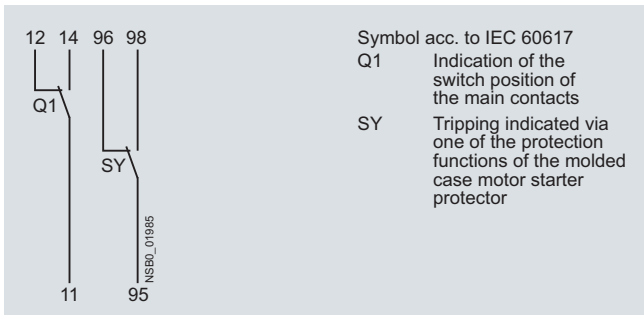

3RV19 91-1BA0, 3RV19 91-1CA0

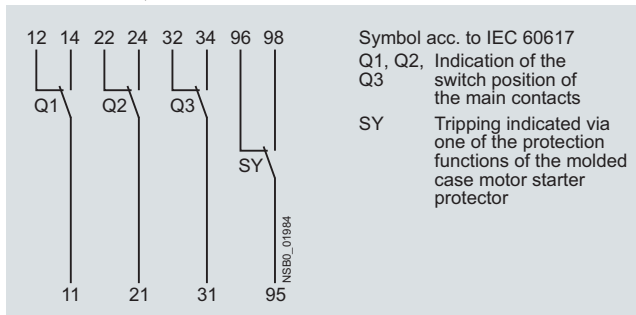

Circuit diagrams

Auxiliary trip units

3RV19 .2-1A.0

Undervoltage trip unit

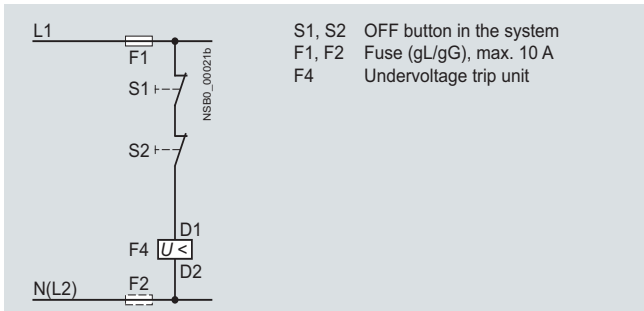

3RV19 .2-1E.0

Shunt trip unit

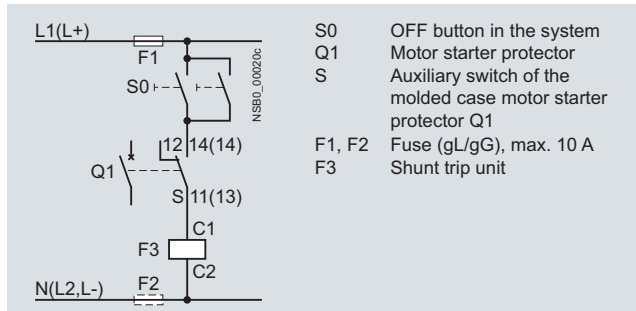

3RV Molded Case Motor Starter Protectors up to 800 A

Accessories

Project planning aids

Dimensional drawings

3RV13 53 molded case motor starter protectors

Mountable accessories

Front-accessible standard terminals

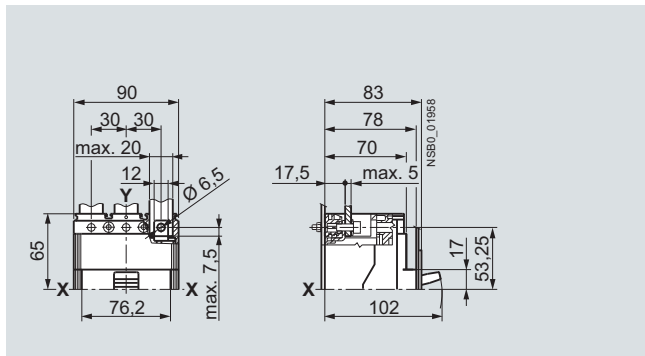

Front-extended terminals

3RV19 55-1AA0

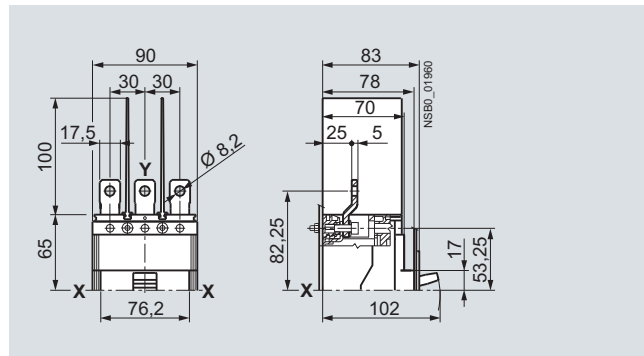

Rear-accessible terminals

3RV19 55-3AA0

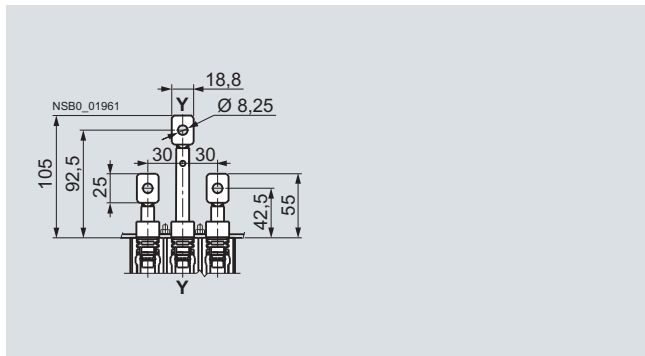

Front-extended cable terminals

3RV19 55-2AA0

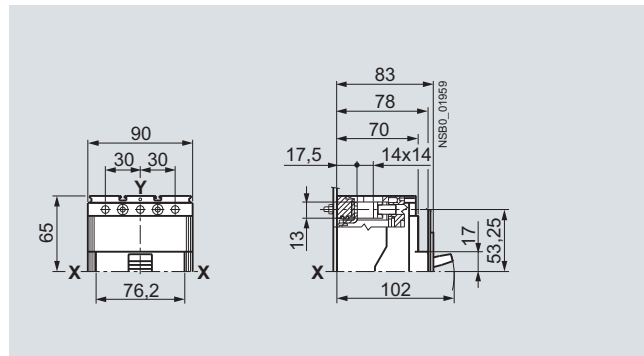

Rotary operating mechanisms

3RV19 56-0BA0 lever-type rotary operating mechanism on switchgear panel door

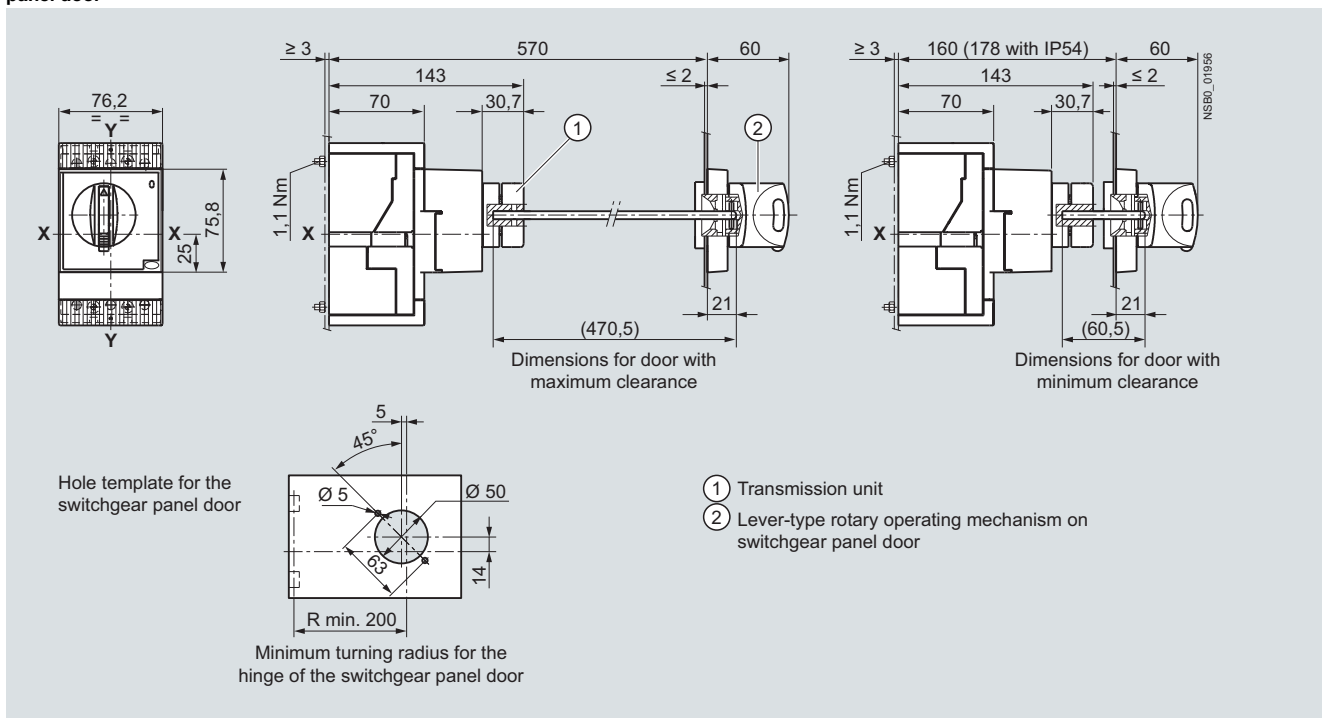

3RV1. 6. and 3RV1. 7. molded case motor starter protectors

Mountable accessories

Front-accessible standard terminals

For 3RV1. 6. molded case motor starter protectors

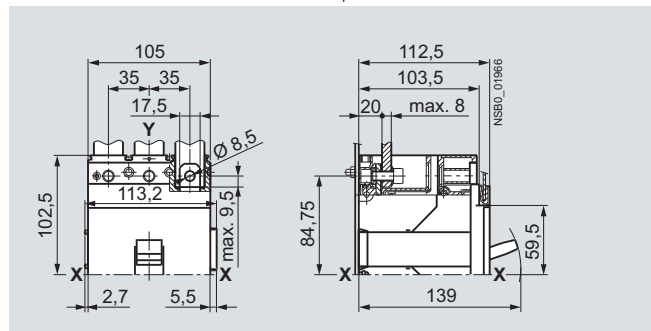

For 3RV1. 7. molded case motor starter protectors

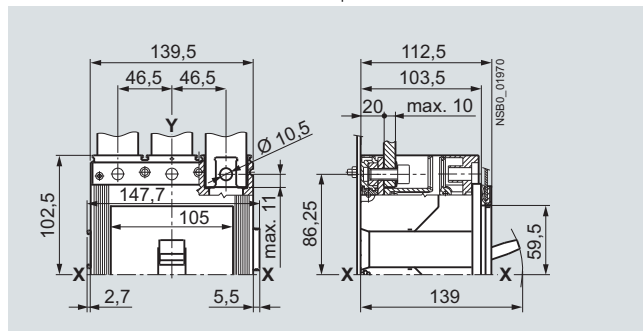

Front-extended terminals

3RV19 65-1BA0 for 3RV1. 6. molded case motor starter protectors

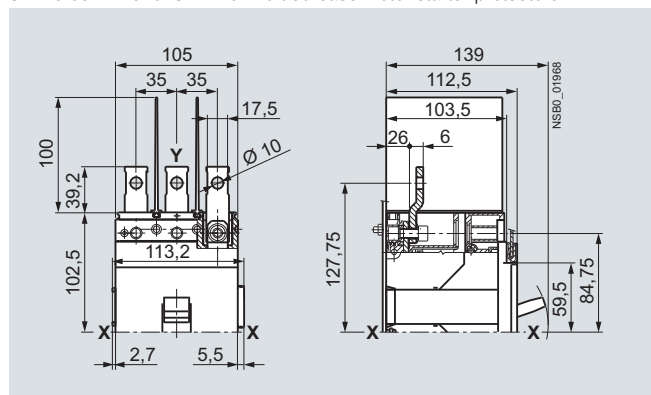

3RV19 75-1CA0 for 3RV1. 7. molded case motor starter protectors

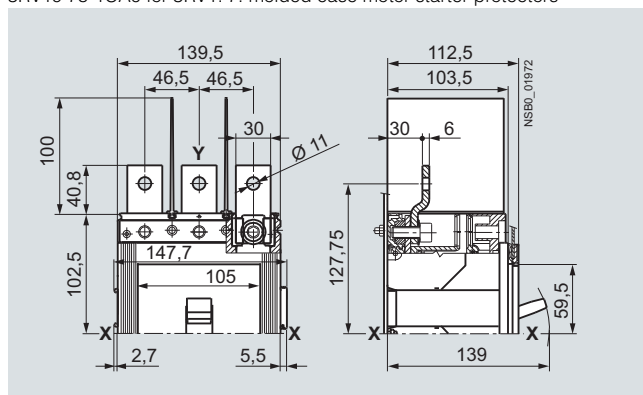

Rear-accessible terminals

3RV19 65-3AA0 for 3RV1. 6. molded case motor starter protectors

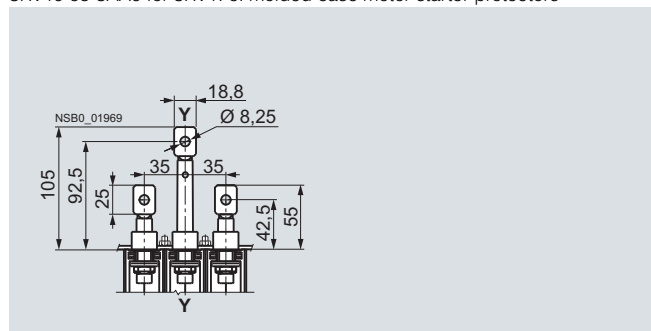

3RV19 75-3AA0 for 3RV1. 7. molded case motor starter protectors

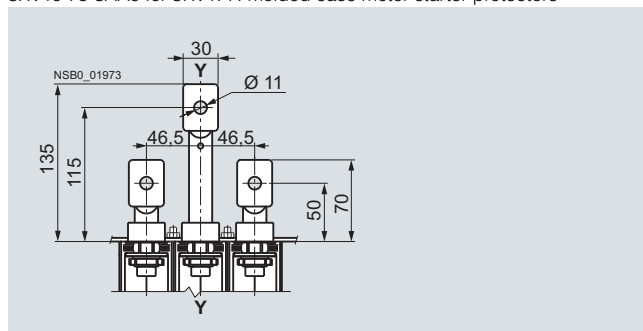

Front-extended cable terminals

3RV19 65-2BA0 for 3RV1. 6. molded case motor starter protectors

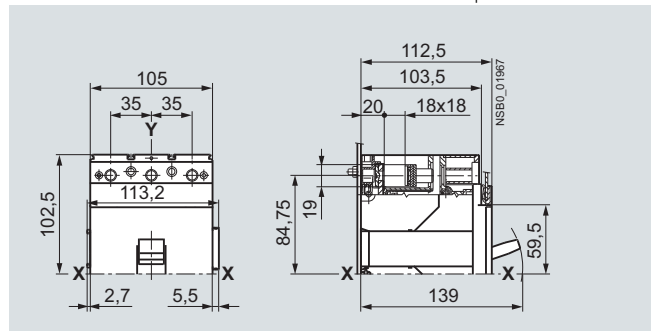

3RV19 75-2CA0 for 3RV1. 7. molded case motor starter protectors

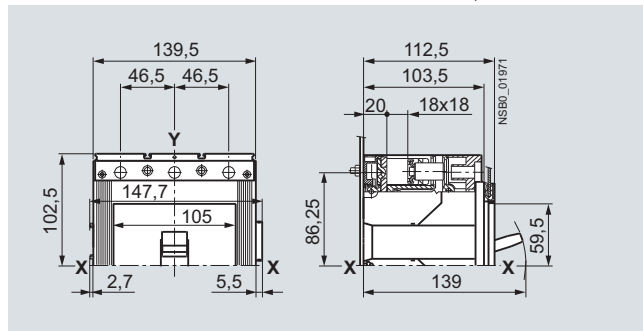

3RV Molded Case Motor Starter Protectors up to 800 A Accessories

Project planning aids

Rotary operating mechanisms

3RV19 76-0BA0 lever-type rotary operating mechanism on switchgear panel door

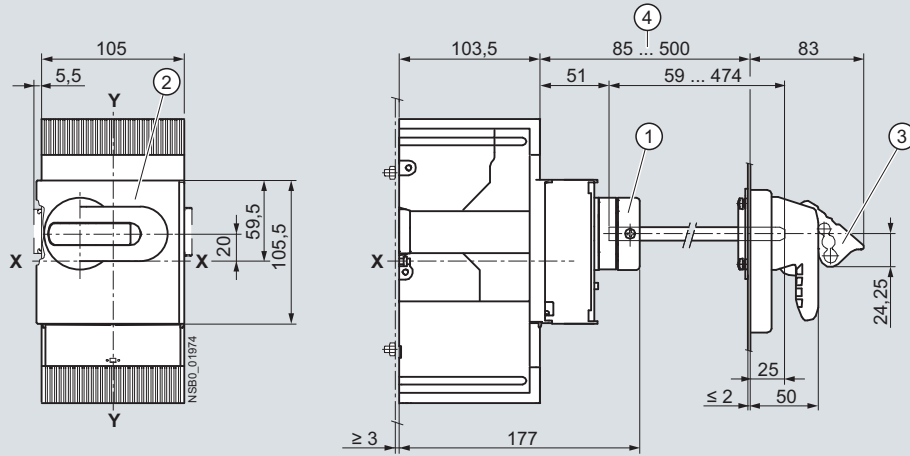

Cut-out in the switchgear panel door

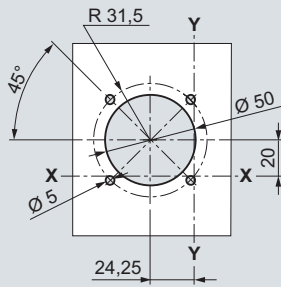

- ① Transmission unit
- ② Rotary lever set with door interlocking device
- ③ Lock interlocking in OFF position (max. 3 padlocks; not included in the scope of supply)
- ④ Min. and max. distance from the front side of the switchgear panel door

5

3RV Molded Case Motor Starter Protectors up to 800 A

Accessories

Project planning aids

3RV1. 83 molded case motor starter protectors

Mountable accessories

Front-accessible standard terminals

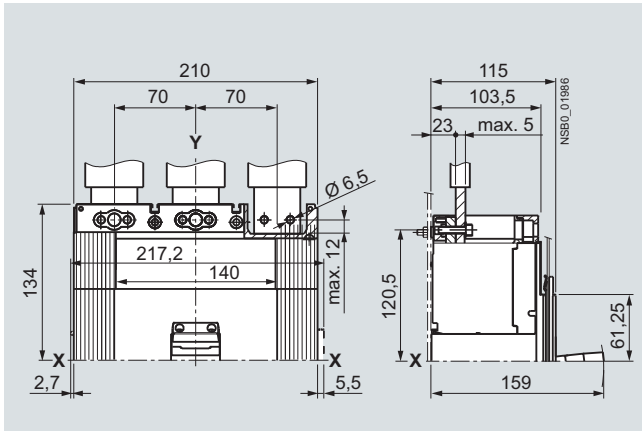

Front-extended terminals

3RV19 85-1DA0, 3RV19 85-1EA00

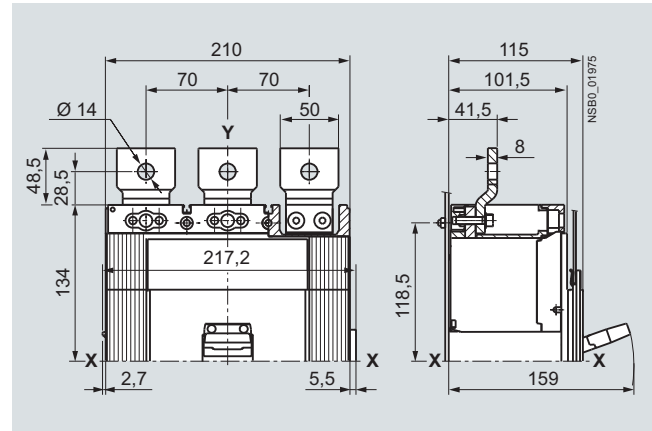

Rear-accessible terminals

3RV19 85-3AA0

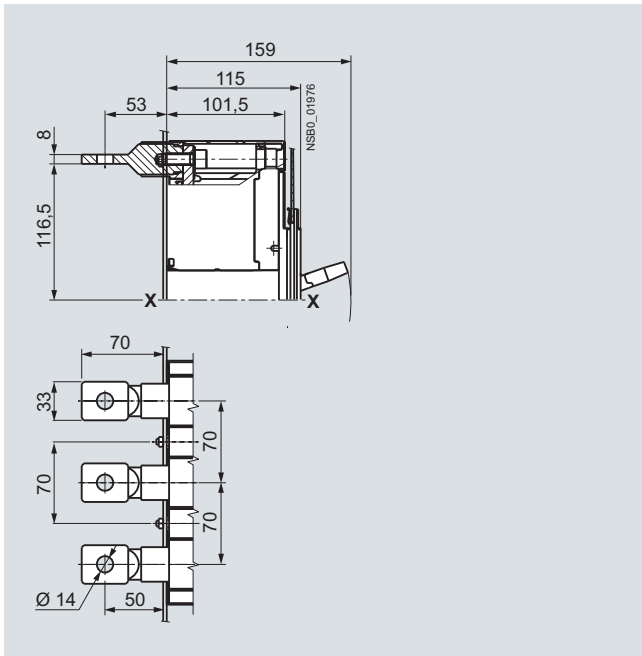

3RV Molded Case Motor Starter Protectors up to 800 A

Accessories

Project planning aids

Rotary operating mechanisms

3RV19 86-0BA0 lever-type rotary operating mechanism on switchgear panel door

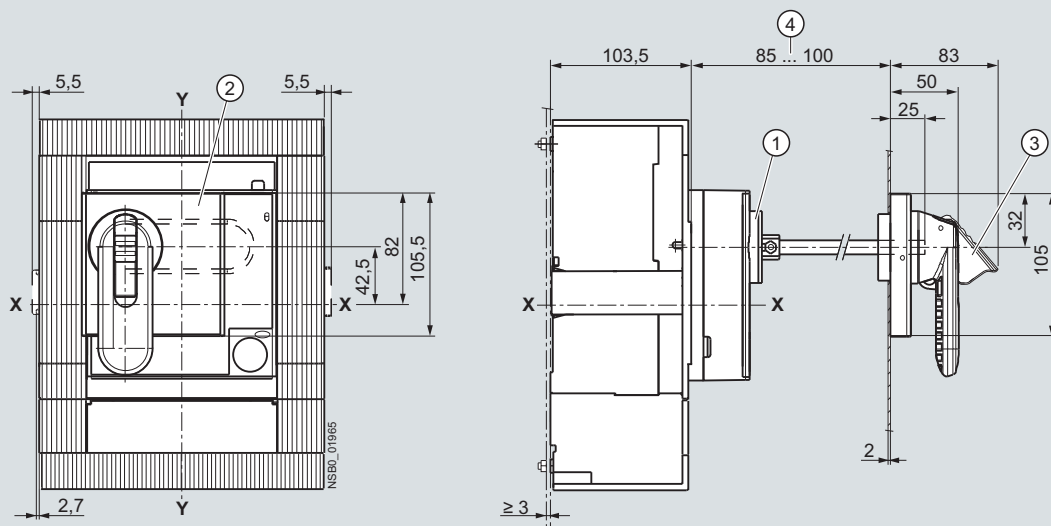

Cut-out in the switchgear panel door

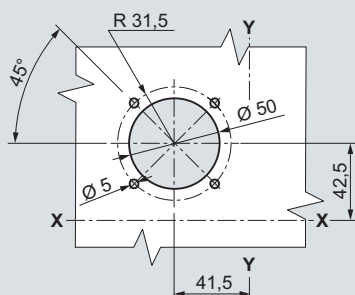

- ① Transmission unit
- ② Rotary lever set with door interlocking device
- ③ Lock interlocking in OFF position (max. 3 padlocks; not included in the scope of supply)
- ④ Min. and max. distance from the front side of the switchgear panel door

Overview



Features	Benefits	3RU11	3RB20/3RB21	3RB22/3RB23
General data				
Sizes	<ul style="list-style-type: none"> Are coordinated with the dimensions, connections and technical characteristics of the other devices in the SIRIUS modular system (contactors, soft starters, ...) Permit the mounting of slim and compact load feeders in widths of 45 mm (S00), 45 mm (S0), 55 mm (S2), 70 mm (S3), 120 mm (S6) and 145 mm (S10/S12) Simplify configuration 	S00 ... S3	S00 ... S12	S00 ... S12
Seamless current range	<ul style="list-style-type: none"> Allows easy and consistent configuration with one series of overload relays (for small to large loads) 	0.11 ... 100 A	0.1 ... 630 A	0.3 ... 630 A (... 820 A) ¹⁾
Protection functions				
Tripping in the event of overload	<ul style="list-style-type: none"> Provides optimum inverse-time delayed protection of loads against excessive temperature rises due to overload 	✓	✓	✓
Tripping in the event of phase unbalance	<ul style="list-style-type: none"> Provides optimum inverse-time delayed protection of loads against excessive temperature rises due to phase unbalance 	(✓)	✓	✓
Tripping in the event of phase failure	<ul style="list-style-type: none"> Minimizes heating of induction motors during phase failure 	✓	✓	✓
Protection of single-phase loads	<ul style="list-style-type: none"> Enables the protection of single-phase loads 	✓	--	✓
Tripping in the event of overheating by integrated thermistor motor protection function	<ul style="list-style-type: none"> Provides optimum temperature-dependent protection of loads against excessive temperature rises, e. g. for stator-critical motors or in the event of insufficient coolant flow, contamination of the motor surface or for long starting or braking operations Eliminates the need for additional special equipment Saves space in the control cabinet Reduces wiring outlay and costs 	-- ²⁾	-- ²⁾	✓
Tripping in the event of a ground fault by internal ground-fault detection (activatable)	<ul style="list-style-type: none"> Provides optimum protection of loads against high-resistance short-circuits or ground faults due to moisture, condensed water, damage to the insulation material, etc. Eliminates the need for additional special equipment. Saves space in the control cabinet Reduces wiring outlay and costs 	--	✓ (only 3RB21)	✓
Features				
RESET function	<ul style="list-style-type: none"> Allows manual or automatic resetting of the relay 	✓	✓	✓
Remote RESET function	<ul style="list-style-type: none"> Allows the remote resetting of the relay 	✓ (by means of separate module)	✓ (only 3RB21 with 24 V DC)	✓
TEST function for auxiliary contacts	<ul style="list-style-type: none"> Allows easy checking of the function and wiring 	✓	✓	✓
TEST function for electronics	<ul style="list-style-type: none"> Allows checking of the electronics 	--	✓	✓
Status display	<ul style="list-style-type: none"> Displays the current operating state 	✓	✓	✓
Large current adjustment button	<ul style="list-style-type: none"> Makes it easier to set the relay exactly to the correct current value 	✓	✓	✓
Integrated auxiliary contacts (1 NO + 1 NC)	<ul style="list-style-type: none"> Allows the load to be switched off if necessary Can be used to output signals 	✓	✓	✓ (2 ×)

¹⁾ Motor currents up to 820 A can be recorded and evaluated by a current measuring module, e. g. 3RB29 06-2BG1 (0.3 ... 3 A), in combination with a 3UF18 68-3GA00 (820 A/1 A) series transformer.

²⁾ The SIRIUS 3RN thermistor motor protection devices can be used to provide additional temperature-dependent protection.

Overload Relays

General data



Features	Benefits	3RU11	3RB20/3RB21	3RB22/3RB23
Design of load feeders				
Short-circuit strength up to 100 kA at 690 V (in conjunction with the corresponding fuses or the corresponding motor starter protector)	<ul style="list-style-type: none"> Provides optimum protection of the loads and operating personnel in the event of short-circuits due to insulation faults or faulty switching operations 	✓	✓	✓
Electrical and mechanical matching to 3RT1 contactors	<ul style="list-style-type: none"> Simplifies configuration Reduces wiring outlay and costs Enables stand-alone installation as well as space-saving direct mounting 	✓	✓	✓ ¹⁾
Straight-through transformers for main circuit²⁾ (in this case the cables are routed through the feed-through openings of the overload relay and connected directly to the box terminals of the contactor)	<ul style="list-style-type: none"> Reduces the contact resistance (only one point of contact) Saves wiring costs (easy, no need for tools, and fast) Saves material costs Reduces installation costs 	--	(S2 ... S6)	(S00 ... S6)
Spring-type terminal connection system for main circuit²⁾	<ul style="list-style-type: none"> Enables fast connections Permits vibration-resistant connections Enables maintenance-free connections 	✓ (S00)	--	--
Spring-type terminal connection system for auxiliary circuits²⁾	<ul style="list-style-type: none"> Enables fast connections Permits vibration-resistant connections Enables maintenance-free connections 	✓	✓	✓
Other features				
Temperature compensation	<ul style="list-style-type: none"> Allows the use of the relays at high temperatures without derating Prevents premature tripping Allows compact installation of the control cabinet without distance between the devices/load feeders Simplifies configuration Enables space to be saved in the control cabinet 	✓	✓	✓
Very high long-term stability	<ul style="list-style-type: none"> Provides safe protection for the loads even after years of use in severe operating conditions 	(✓)	✓	✓
Wide setting ranges	<ul style="list-style-type: none"> Reduce the number of variants Minimize the engineering outlay and costs Minimize storage overhead, storage costs, tied-up capital 	--	✓ (1:4)	✓ (1:10)
Trip class CLASS 5	<ul style="list-style-type: none"> Enables solutions for very fast starting motors requiring special protection (e. g. Ex motors) 	--	✓ (only 3RB21)	✓
Trip classes > CLASS 10	<ul style="list-style-type: none"> Enables heavy starting solutions 	--	✓	✓
Low power loss	<ul style="list-style-type: none"> Reduces power consumption and energy costs (up 98 % less power is used than for thermal overload relays). Minimizes temperature rises of the contactor and control cabinet – in some cases this may eliminate the need for controlgear cabinet cooling. Direct mounting to contactor saves space, even for high motor currents (i. e. no heat decoupling is required). 	--	✓	✓

¹⁾ Exception: up to size S3, only stand-alone installation is possible.

²⁾ Alternatively available for screw terminals.



Features	Benefits	3RU11	3RB20/3RB21	3RB22/3RB23
Other features				
Internal power supply	<ul style="list-style-type: none"> Eliminates the need for configuration and connecting an additional control circuit 	-- ¹⁾	✓	--
Variable adjustment of the trip classes (The required trip class can be adjusted by means of a rotary switch depending on the current start-up condition.)	<ul style="list-style-type: none"> Reduces the number of variants Minimizes the configuring outlay and costs Minimizes storage overhead, storage costs, and tied-up capital 	--	✓ (only 3RB21)	✓
Overload warning	<ul style="list-style-type: none"> Indicates imminent tripping of the relay directly on the device due to overload, phase unbalance or phase failure Allows the imminent tripping of the relay to be signaled Allows measures to be taken in time in the event of continuous inverse-time delayed overloads Eliminates the need for an additional device Saves space in the control cabinet Reduces wiring outlay and costs 	--	--	✓
Analog output	<ul style="list-style-type: none"> Allows the output of an analog output signal for actuating moving-coil instruments, feeding programmable logic controllers or transfer to bus systems Eliminates the need for an additional measuring transducer and signal converter Saves space in the control cabinet Reduces wiring outlay and costs 	--	--	✓

¹⁾ The SIRIUS 3RU11 thermal overload relays use a bimetal contactor and therefore do not require a control supply voltage.

Overload Relays

General data

Overload relay	Current measurement	Current range	Contactors (type, size, rating in kW)							
			3RT10 1	3RT10 2	3RT10 3	3RT10 4	3RT10 5	3RT10 6	3RT10 7	3TF68/69
Type	Type	A	S00 3/4/5.5	S0 5.5/7.5/11	S2 15/18.5/22	S3 30/37/45	S6 55/75/90	S10 110/132/160	S12 200/250	Size 14 375/450

3RU11 thermal overload relays



3RU11 1	Integrated	0.11 ... 12	✓	--	--	--	--	--	--	--
3RU11 2	Integrated	1.8 ... 25	--	✓	--	--	--	--	--	--
3RU11 3	Integrated	5.5 ... 50	--	--	✓	--	--	--	--	--
3RU11 4	Integrated	18 ... 100	--	--	--	✓	--	--	--	--

3RB20¹⁾ solid-state overload relays



3RB20 1	Integrated	0.1 ... 12	✓	--	--	--	--	--	--	--
3RB20 2	Integrated	0.1 ... 25	--	✓	--	--	--	--	--	--
3RB20 3	Integrated	6 ... 50	--	--	✓	--	--	--	--	--
3RB20 4	Integrated	12.5 ... 100	--	--	--	✓	--	--	--	--
3RB20 5	Integrated	50 ... 200	--	--	--	--	✓	--	--	--
3RB20 6	Integrated	55 ... 630	--	--	--	--	--	✓	✓	✓
3RB20 1 + 3UF18	Integrated	630 ... 820	--	--	--	--	--	--	--	✓

3RB21¹⁾ solid-state overload relays



3RB21 1	Integrated	0.1 ... 12	✓	--	--	--	--	--	--	--
3RB21 2	Integrated	0.1 ... 25	--	✓	--	--	--	--	--	--
3RB21 3	Integrated	6 ... 50	--	--	✓	--	--	--	--	--
3RB21 4	Integrated	12.5 ... 100	--	--	--	✓	--	--	--	--
3RB21 5	Integrated	50 ... 200	--	--	--	--	✓	--	--	--
3RB21 6	Integrated	55 ... 630	--	--	--	--	--	✓	✓	✓
3RB21 1 + 3UF18	Integrated	630 ... 820	--	--	--	--	--	--	--	✓

3RB22/3RB23¹⁾ solid-state overload relays



3RB22/3RB23 +	3RB29 0	0.3 ... 25	✓	✓	--	--	--	--	--	--
	3RB29 0	10 ... 100	--	--	✓	✓	--	--	--	--
	3RB29 5	20 ... 200	--	--	--	--	✓	--	--	--
	3RB29 6	63 ... 630	--	--	--	--	--	✓	✓	✓
	3RB29 0 + 3UF18	630 ... 820	--	--	--	--	--	--	--	✓

¹⁾ When using the overload relays with trip class \geq CLASS 20, see "Technical specifications", "Short-Circuit Protection with Fuses for Motor Feeders", and the project planning aid "Configuring SIRIUS Fuseless Load Feeders".

Connection methods

The 3RB20 and 3RB21 relays are available with screw terminals (box terminals) or spring-type terminals on the auxiliary current side; the same applies for the evaluation modules of the 3RB22/3RB23 relays.

The 3RU11 relays come with screw terminals.



Screw terminals (box terminals)



Spring-type terminals

These connections are indicated in the Technical specifications by orange backgrounds.

Overload Relays

3RU1 Thermal Overload Relays

3RU11 for standard applications

Overview

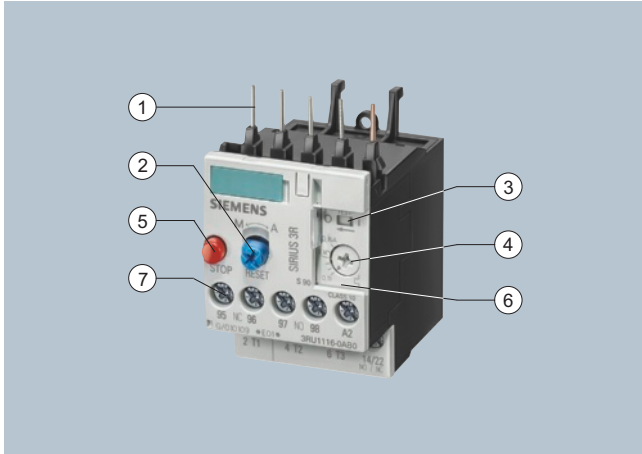

- (1) Connection for mounting onto contactors:
Optimally adapted in electrical, mechanical and design terms to the contactors and soft starters, these connecting pins can be used for direct mounting of the overload relays. Stand-alone installation is possible as an alternative (in some cases in conjunction with a stand-alone installation module).
- (2) Selector switch for manual/automatic RESET and RESET button:
With this switch you can choose between manual and automatic RESET. A device set to manual RESET can be reset locally by pressing the RESET button. A remote RESET is possible using the RESET modules (accessories), which are independent of size.
- (3) Switch position indicator and TEST function of the wiring:
Indicates a trip and enables the wiring test.
- (4) Motor current setting:
Setting the device to the rated motor current is easy with the large rotary knob.
- (5) STOP button:
If the STOP button is pressed, the NC contact is opened. This switches off the contactor downstream. The NC contact is closed again when the button is released.
- (6) Transparent sealable cover
Secures the motor current setting and the TEST function against adjustment.
- (7) Supply terminals:
The generously sized terminals permit connection of two conductors with different cross-sections for the main and auxiliary circuits. The auxiliary circuit can be connected with screw terminals and alternatively with spring-type terminals.

The 3RU11 thermal overload relays up to 100 A have been designed for inverse-time delayed protection of loads with normal starting (see "Function") against excessive temperature rises due to overload or phase failure. An overload or phase failure results in an increase of the motor current beyond the set rated motor current. Via heating elements, this current rise heats up the bimetal strips inside the device which then bend and as a result trigger the auxiliary contacts by means of a tripping mechanism. The auxiliary contacts then switch off the load by means of a contactor. The break time depends on the ratio between the tripping current and current setting I_{e} and is stored in the form of a long-term stable tripping characteristic (see "Characteristic Curves").

The "tripped" status is signaled by means of a switch position indicator. Resetting takes place either manually or automatically after the recovery time has elapsed (see "Function").

The devices are manufactured in accordance with environmental guidelines and contain environmentally friendly and reusable materials.

They comply with all important worldwide standards and approvals.

"Increased safety" type of protection EEx e acc. to ATEX directive 94/9/EC

The 3RU11 thermal overload relays are suitable for the overload protection of explosion-proof motors with "increased safety" type of protection EEx e;

see Catalog LV 1, Chapter 20 "Appendix" --> "Standards and approvals" --> "Type overview of approved devices for explosion-protected areas (ATEX Explosion Protection)".

EC type test certificate for Category (2) G/D exists. It has the number DMT 98 ATEX G 001.

Design

Device concept

The 3RU11 thermal overload relays are compact devices, i. e. current measurement and the evaluation unit are integrated in a single enclosure.

Mounting options

The 3RU11 thermal overload relays can be mounted directly onto the 3RT1 contactors (exception: size S00 with Cage Clamp terminals can only be installed as a stand-alone installation). With the matching terminal brackets the devices can still be installed as stand-alone units.

For more information on the mounting options see "Technical specifications" and Catalog LV 1, "Selection and ordering data".

Connection methods

All sizes of the 3RU11 thermal overload relays with screw terminal can be connected to the auxiliary and main current paths. Rails can be connected to the main conductor connections of size S3 overload relays if the box terminals are removed.

As an alternative, the devices are also available with Cage Clamp terminals. The auxiliary conductor connections of these devices, and for size S00 the main conductor connections as well, are fitted with Cage Clamp terminals.

For more information on the connection options see "Technical specifications" and Catalog LV 1, "Selection and ordering data".

Overload relays in contactor assemblies for wye-delta starting

When overload relays are used in combination with contactor assemblies for wye-delta starting it must be noted that only 0.58 times the motor current flows through the line contactor. An overload relay mounted onto the line contactor must be set to 0.58 times the motor current.

An assignment of the 3RU11 thermal overload relays to the line contactors of our 3RA contactor assemblies for wye-delta starting can be found in Chapter 3 "Controls: Contactors and Contactor Assemblies".

Operation with frequency converter

The 3RU11 thermal overload relays are suitable for operation with frequency converters. Depending on the frequency of the converter, a higher current than the motor current must be used in some cases due to eddy-currents and skin effects.

Overload Relays

3RU1 Thermal Overload Relays

3RU11 for standard applications

Function

Basic functions

The 3RU11 thermal overload relays are designed for:

- Inverse-time delayed protection of loads from overloading
- Inverse-time delayed protection of loads from phase failure

Control circuit

The 3RU11 thermal overload relays do not require an additional supply voltage for operation.

Short-circuit protection

Fuses or motor starter protectors must be used for short-circuit protection.

For assignments of the corresponding short-circuit protection devices to the 3RU11 thermal overload relays with/without contactor see "Technical specifications" and Catalog LV 1, "Selection and ordering data".

Trip classes

The 3RU11 thermal overload relays are available for normal starting conditions with trip class CLASS 10. For heavy starting conditions see 3RB2 solid-state overload relays.

For details of the trip classes see "Characteristic Curves".

Phase failure protection

The 3RU11 thermal overload relays are fitted with phase failure sensitivity (see "Characteristic Curves") in order to minimize temperature rises of the load in the case of a phase failure during single-phase operation.

Setting

The 3RU11 thermal overload relays are set to the rated motor current by means of a rotary knob. The scale of the rotary knob is shown in ampere.

Manual and automatic reset

Automatic and manual reset is selected by pressing and turning the blue button (RESET button). If the button is set to manual reset, the overload relay can be reset directly by pressing the RESET button. Resetting is possible in combination with mechanical and electrical reset options from the range of accessories (see Catalog LV 1, "Accessories"). If the blue button is set to automatic RESET, the relay is reset automatically.

The time between tripping and resetting is determined by the recovery time.

Recovery time

After tripping due to overload, the 3RU11 thermal overload relays require some time until the bimetal strips have cooled down. The device can only be reset after the bimetal strips have cooled down. This time (recovery time) depends on the tripping characteristics and strength of the tripping current.

The recovery time allows the load to cool down after tripping due to overload.

TEST function

The TEST slide can be used to check whether the operational 3RU11 thermal overload relay is working properly. Actuating the slide simulates tripping of the relay. During this simulation the NC contact (95-96) is opened and the NO contact (97-98) is closed. This tests whether the auxiliary circuit has been correctly connected to the overload relay. If the 3RU11 thermal overload relay has been set to automatic RESET, the overload relay is automatically reset when the TEST slide is released. The relay must be reset with the RESET button if it has been set to manual RESET.

STOP function

If the STOP button is pressed, the NC contact is opened. This switches off the contactor downstream and thus the load. The load is switched on again when the STOP button is released.

Display of the operating state

The respective operating state of the 3RU11 thermal overload relay is displayed by means of the position of the marking on the TEST function/switch position indicator slide. After tripping due to overload or phase failure, the marking on the slide is to left on the "O" mark, otherwise it is on the "I" mark.

Auxiliary contacts

The 3RU11 thermal overload relays are fitted with an NO contact for the tripped signal, and an NC contact for disconnecting the contactor.

Overload Relays

3RU1 Thermal Overload Relays

3RU11 for standard applications

Technical specifications

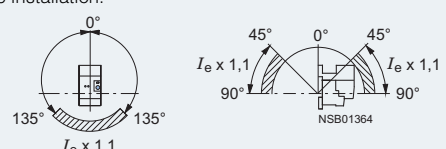

Type	3RU11 16	3RU11 26	3RU11 36	3RU11 46
Size	S00	S0	S2	S3
Width	45 mm	45 mm	55 mm	70 mm
General data				
Trips in the event of	Overload and phase failure			
Trip class acc. to IEC 60947-4-1	CLASS	10		
Phase failure sensitivity	Yes			
Overload warning	No			
Reset and recovery	Manual, automatic and remote RESET ¹⁾			
• Reset options after tripping				
• Recovery time				
- For automatic RESET	min	Depends on the strength of the tripping current and characteristic		
- For manual RESET	min	Depends on the strength of the tripping current and characteristic		
- For remote RESET	min	Depends on the strength of the tripping current and characteristic		
Features				
• Display of operating state on device	Yes, by means of TEST function/switch position indicator slide			
• TEST function	Yes			
• RESET button	Yes			
• STOP button	Yes			
Safe operation of motors with "increased safety" type of protection				
EC type test certificate number acc. to directive 94/9/EC	DMT 98 ATEX G 001  II (2) GD, DMT 98 ATEX G 001 N1			
Ambient temperature				
• Storage/transport	°C	-55 ... +80		
• Operation	°C	-20 ... +70		
• Temperature compensation	°C	Up to 60		
• Permissible rated current at				
- Temperature inside control cabinet 60 °C	%	100 (over +60 °C current reduction is not required)		
- Temperature inside control cabinet 70 °C	%	87		
Repeat terminals				
• Coil repeat terminal	Yes	Not required		
• Auxiliary contact repeat terminal	Yes	Not required		
Degree of protection acc. to IEC 60529	IP20		IP20 ²⁾	
Touch protection acc. to IEC 61140	Finger-safe			
Shock resistance with sine acc. to IEC 60068-2-27	g/ms	8/10		
Electromagnetic compatibility (EMC) – Interference immunity				
• Conductor-related interference				
- Burst acc. to IEC 61000-4-4 (corresponds to degree of severity 3)	kV	EMC interference immunity is not relevant for thermal overload relays		
- Surge acc. to IEC 61000-4-5 (corresponds to degree of severity 3)	kV	EMC interference immunity is not relevant for thermal overload relays		
• Electrostatic discharge acc. to IEC 61000-4-2 (corresponds to degree of severity 3)	kV	EMC interference immunity is not relevant for thermal overload relays		
• Field-related interference acc. to IEC 61000-4-3 (corresponds to degree of severity 3)	V/m	EMC interference immunity is not relevant for thermal overload relays		
Electromagnetic compatibility (EMC) – Emitted interference	EMC interference immunity is not relevant for thermal overload relays			
Resistance to extreme climates – Air humidity	%	100		
Dimensions	See dimensional drawings			
Installation altitude above sea level	m	Up to 2000; above this, please enquire		
Mounting position	<p>The diagrams show the permissible mounting positions for mounting onto contactors and stand-alone installation. For installation in the hatched area, a setting correction of 10 % must be implemented.</p> <p>Stand-alone installation:</p> 			
Type of mounting	Direct mounting ^{3)/} stand-alone installation with terminal bracket ⁴⁾	Direct mounting/stand-alone installation with terminal bracket ⁴⁾		

Footnotes see page 5/62.

Overload Relays

3RU1 Thermal Overload Relays

3RU11 for standard applications

Type		3RU11 16	3RU11 26	3RU11 36	3RU11 46
Size		S00	S0	S2	S3
Width		45 mm	45 mm	55 mm	70 mm
Main circuit					
Rated insulation voltage U_i (degree of pollution 3)	V	690			1000
Rated impulse withstand voltage U_{imp}	kV	6			8
Rated operational voltage U_e	V	690			1000
Type of current		Yes			
• Direct current		Yes, frequency range up to 400 Hz			
• Alternating current					
Current setting	A	0.11 ... 0.16 to 9 ... 12	1.8 ... 2.5 to 20 ... 25	5.5 ... 8 to 40 ... 50	18 ... 25 to 80 ... 100
Power loss per unit (max.)	W	3.9 ... 6.6	3.9 ... 6	6 ... 9	10 ... 16.5
Short-circuit protection		See "Selection and ordering data"			
• With fuse without contactor		See "Technical specifications" (short-circuit protection with fuses/motor starter protectors for motor feeders)			
• With fuse and contactor					
Protective separation between main and auxiliary conducting path acc. to IEC 60947-1	V	500	690		
Connection for main circuit					
Connection type		 Screw terminals with box terminal			
• Terminal screw		Pozi driv size 2			
• Tightening torque	Nm	0.8 ... 1.2	2 ... 2.5	3 ... 4.5	Allen screw 4 mm 4 ... 6
• Conductor cross-sections (min./max.), 1 or 2 conductors					
- Solid	mm ²	2 x (0.5 ... 1.5) ²⁾ 2 x (0.75 ... 2.5) ²⁾ Max. 2 x (1 ... 4) ²⁾	2 x (1 ... 2.5) ²⁾ 2 x (2.5 ... 6) ²⁾ Max. 2 x (2.5 ... 10) ²⁾	2 x (0.75 ... 16)	2 x (2.5 ... 16)
- Finely stranded with end sleeve	mm ²	2 x (0.5 ... 1.5) ²⁾ 2 x (0.75 ... 2.5) ²⁾	2 x (1 ... 2.5) ²⁾ 2 x (2.5 ... 6) ²⁾	2 x (0.75 ... 16) 1 x (0.75 ... 25)	2 x (2.5 ... 35) 1 x (2.5 ... 50)
- Stranded	mm ²	2 x (0.5 ... 1.5) ²⁾ 2 x (0.75 ... 2.5) ²⁾ Max. 2 x (1 ... 4) ²⁾	2 x (1 ... 2.5) ²⁾ 2 x (2.5 ... 6) ²⁾ Max. 2 x (2.5 ... 10) ²⁾	2 x (0.75 ... 25) 1 x (0.75 ... 35)	2 x (10 ... 50) 1 x (10 ... 70)
- AWG cables, solid or stranded	AWG	2 x (18 ... 14)	2 x (14 ... 10)	2 x (18 ... 3) 1 x (18 ... 1)	2 x (10 ... 1/0) 1 x (10 ... 2/0)
- Ribbon cable conductors (number x width x thickness)	mm	--	--	2 x (6 x 9 x 0.8)	2 x (6 x 9 x 0.8)
Busbar connections		 Busbar connection¹⁾			
• Terminal screw		--	--	--	M6 x 20
• Tightening torque	Nm	--	--	--	4 ... 6
• Conductor cross-sections (min./max.)					
- Finely stranded with cable lug	mm ²	--	--	--	2 x 70
- Stranded with cable lug	mm ²	--	--	--	3 x 70
- AWG cables, solid or stranded, with cable lug	AWG	--	--	--	2/0
- With connecting bar (max. width)	mm	--	--	--	12
Connection type		 Cage Clamp terminals			
• Conductor cross-sections (min./max.)					
- Solid	mm ²	2 x (0.25 ... 2.5)	--	--	--
- Finely stranded without end sleeve	mm ²	2 x (0.25 ... 2.5)	--	--	--
- Finely stranded with end sleeve	mm ²	2 x (0.25 ... 1.5)	--	--	--
- Stranded	mm ²	--	--	--	--
- AWG cables, solid or stranded	AWG	2 x (24 ... 14)	--	--	--

Footnotes for page 5/61:

- 1) Remote RESET in combination with the corresponding accessories.
- 2) Terminal compartment: degree of protection IP00.
- 3) The 3RU11 16 overload relay with Cage Clamp terminals can only be installed as a stand-alone installation.
- 4) For screw and snap-on mounting TH 35 standard mounting rail; size S3 also for TH 75 standard mounting rail. For more detailed information about terminal brackets see "Accessories" --> "Technical specifications".



Footnotes for page 5/62:

- 1) The box terminal is removable. Rail and cable lug connections are possible if the box terminal is removed.
- 2) If two different conductor cross-sections are connected to one clamping point, both cross-sections must lie in the range specified. If identical cross-sections are used, this restriction does not apply.

Overload Relays

3RU1 Thermal Overload Relays

3RU11 for standard applications

Type		3RU11 16	3RU11 26	3RU11 36	3RU11 46
Size		S00	S0	S2	S3
Width		45 mm	45 mm	55 mm	70 mm
Auxiliary circuit					
Number of NO contacts		1			
Number of NC contacts		1			
Auxiliary contacts – assignment		1 NO for the signal "tripped", 1 NC for disconnecting the contactor			
Rated insulation voltage U_i (degree of pollution 3)	V	690			
Rated impulse withstand voltage U_{imp}	kV	6			
Contact rating of the auxiliary contacts					
• NC contact with alternating current AC-14/AC-15, rated operational current I_e at U_e :					
- 24 V	A	4			
- 120 V	A	4			
- 125 V	A	4			
- 230 V	A	3			
- 400 V	A	2			
- 600 V	A	0.6			
- 690 V	A	0.5			
• NO contact with alternating current AC-14/AC-15, rated operational current I_e at U_e :					
- 24 V	A	3			
- 120 V	A	3			
- 125 V	A	3			
- 230 V	A	2			
- 400 V	A	1			
- 600 V	A	0.6			
- 690 V	A	0.5			
• NC contact, NO contact with direct current DC-13, rated operational current I_e at U_e :					
- 24 V	A	1			
- 60 V	A	1) 1)			
- 110 V	A	0.22			
- 125 V	A	0.22			
- 220 V	A	0.11			
• Conventional thermal current I_{th}	A	6 ²⁾			
• Contact reliability (suitability for PLC control; 17 V, 5 mA)		Yes			
Short-circuit protection					
• With fuse					
- gL/gG operational class	A	6			
- Quick	A	10			
• With miniature circuit breaker (C characteristic)	A	6			
Protective separation between main and auxiliary conducting path Acc. to IEC 60947-1	V	415			
CSA, UL, UR rated data					
Auxiliary circuit – switching capacity		B600, R300			
Connection of the auxiliary circuit					
Connection type					
 Screw terminals					
• Terminal screw					
Pozidriv size 2					
• Tightening torque	Nm	0.8 ... 1.2			
• Conductor cross-sections (min./max.), 1 or 2 conductors					
- Solid	mm ²	2 x (0.5 ... 1.5) ³⁾ , 2 x (0.75 ... 2.5) ³⁾			
- Finely stranded without end sleeve	mm ²	--			
- Finely stranded with end sleeve	mm ²	2 x (0.5 ... 1.5) ³⁾ , 2 x (0.75 ... 2.5) ³⁾			
- Stranded	mm ²	2 x (0.5 ... 1.5) ³⁾ , 2 x (0.75 ... 2.5) ³⁾			
- AWG cables, solid or stranded	AWG	2 x (18 ... 14)			
Connection type					
 Cage Clamp terminals					
• Conductor cross-sections (min./max.)					
- Solid		2 x (0.25 ... 2.5)			
- Finely stranded without end sleeve		2 x (0.25 ... 2.5)			
- Finely stranded with end sleeve		2 x (0.25 ... 1.5)			
- Stranded		--			
- AWG cables, solid or stranded		2 x (24 ... 14)			

1) On request.

2) Up to $I_k \leq 0.5$ kA; ≤ 260 V.

3) If two different conductor cross-sections are connected to one clamping point, both cross-sections must lie in the range specified. If identical cross-sections are used, this restriction does not apply.

Overload Relays

3RU1 Thermal Overload Relays

3RU11 for standard applications

Short-circuit protection with fuses/motor starter protectors for motor feeders

With short-circuit currents up to 100 kA at rated operational voltages up to AC 50/60 Hz 690 V

Permissible short-circuit protection fuse for motor starters comprising overload relay and contactor, type of coordination 2¹⁾

Overload relay Setting range	3 kW \cong 3RT10 15			4 kW \cong 3RT10 16			5.5 kW \cong 3RT10 17			UL-listed fuses RK5	Motor starter protector for starter combinations at $I_q = 50 \text{ kA}/400 \text{ V AC}$
	$I_{e \text{ max}} = 7 \text{ A}$ (at AC 50 Hz 400 V)			$I_{e \text{ max}} = 9 \text{ A}$ (at AC 50 Hz 400 V)			$I_{e \text{ max}} = 12 \text{ A}$ (at AC 50 Hz 400 V)				
A	gL/gG	aM	BS 88	gL/gG	aM	BS 88	gL/gG	aM	BS 88	A	
Size S00											
0.11 ... 0.16	0.5	--	--	0.5	--	--	0.5	--	--	1	--
0.14 ... 0.2	1	--	--	1	--	--	1	--	--	1	3RV13 21-0BC10
0.18 ... 0.25	1	--	--	1	--	--	1	--	--	1	3RV13 21-0CC10
0.22 ... 0.32	1.6	--	2	1.6	--	2	1.6	--	2	1	3RV13 21-0DC10
0.28 ... 0.4	2	--	2	2	--	2	2	--	2	1.6	3RV13 21-0EC10
0.35 ... 0.5	2	--	2	2	--	2	2	--	2	2	3RV13 21-0FC10
0.45 ... 0.63	2	--	4	2	--	4	2	--	4	2.5	3RV13 21-0GC10
0.55 ... 0.8	4	--	4	4	--	4	4	--	4	3	3RV13 21-0HC10
0.7 ... 1	4	--	6	4	--	6	4	--	6	4	3RV13 21-0JC10
0.9 ... 1.25	4	--	6	4	--	6	4	--	6	5	3RV13 21-0KC10
1.1 ... 1.6	6	--	10	6	--	10	6	--	10	6	3RV13 21-1AC10
1.4 ... 2	6	--	10	6	--	10	6	--	10	8	3RV13 21-1BC10
1.8 ... 2.5	10	--	10	10	--	10	10	--	10	10	--
2.2 ... 3.2	10	--	16	10	--	16	10	--	16	12	--
2.8 ... 4	16	--	16	16	--	16	16	--	16	16	--
3.5 ... 5	20	6	20	20	6	20	20	6	20	20	--
4.5 ... 6.3	20	6	20	20	6	20	20	6	20	25	--
5.5 ... 8	20	10	20	20	10	20	20	10	20	30	--
7 ... 10	--	--	--	20	16	20	20	16	20	40	--
9 ... 12	--	--	--	--	--	--	20	16	25	45	--

Overload relay Setting range	5.5 kW \cong 3RT10 24			7.5 kW \cong 3RT10 25			11 kW \cong 3RT10 26			UL-listed fuses RK5	Motor starter protector for starter combinations at $I_q = 50 \text{ kA}/400 \text{ V AC}$
	$I_{e \text{ max}} = 12 \text{ A}$ (at AC 50 Hz 400 V)			$I_{e \text{ max}} = 17 \text{ A}$ (at AC 50 Hz 400 V)			$I_{e \text{ max}} = 25 \text{ A}$ (at AC 50 Hz 400 V)				
A	gL/gG	aM	BS 88	gL/gG	aM	BS 88	gL/gG	aM	BS 88	A	
Size S0											
1.8 ... 2.5	10	--	10	10	--	10	10	--	10	10	3RV13 21-1CC10
2.2 ... 3.2	10	--	16	10	--	16	10	--	16	12	3RV13 21-1DC10
2.8 ... 4	16	--	16	16	--	16	16	--	16	16	3RV13 21-1EC10
3.5 ... 5	20	6	20	20	6	20	20	6	20	20	3RV13 21-1FC10
4.5 ... 6.3	20	6	25	20	6	25	20	6	25	25	3RV13 21-1GC10
5.5 ... 8	25	10	25/32 ²⁾	25	10	25/32 ²⁾	25	10	32	30	3RV13 21-1HC10
7 ... 10	25	16	25/32 ²⁾	25	16	25/32 ²⁾	32	16	35	40	3RV13 21-1JC10
9 ... 12.5	25	20	25/32 ²⁾	25	20	25/32 ²⁾	35	20	35	45	3RV13 21-1KC10
11 ... 16	25	20	25/32 ²⁾	25	20	25/32 ²⁾	35	20	35	60	3RV13 21-4AC10
14 ... 20	--	--	--	25	20	25/32 ²⁾	35	20	35	80	3RV13 21-4BC10
17 ... 22	--	--	--	--	--	--	35	20	35	80	3RV13 21-4CC10
20 ... 25	--	--	--	--	--	--	35	20	35	100	--

For type of coordination "1"¹⁾ see short-circuit protection of the contactors without overload relay under "Controls - Contactors and Contactor Assemblies".

1) Assignment and short-circuit protective devices according to IEC 60947-4-1:

The contactor or starter must not endanger persons or the installation in the event of a short-circuit.

Type of coordination "1": The contactor or the starter may be non-operational after every short-circuit release.

Type of coordination "2": The contactor or the starter must be operational after a short-circuit release (without replacement of parts). Welding of the contacts is permissible however.

2) At max. 415 V.

Overload Relays

3RU1 Thermal Overload Relays

3RU11 for standard applications

Short-circuit protection with fuses/motor starter protectors for motor feeders

With short-circuit currents up to 100 kA at rated operational voltages up to AC 50/60 Hz 690 V

Permissible short-circuit protection fuse for motor starters comprising overload relay and contactor, type of coordination 2¹⁾

Overload relay Setting range	15 kW \cong 3RT10 34			18.5 kW \cong 3RT10 35			22 kW \cong 3RT10 36			UL-listed fuses RK5	Motor starter protector for starter combinations at $I_q = 50$ kA/400 V AC
	$I_{e\max} = 32$ A (at AC 50 Hz 400 V)			$I_{e\max} = 40$ A (at AC 50 Hz 400 V)			$I_{e\max} = 50$ A (at AC 50 Hz 400 V)				
A	gL/gG	aM	BS 88	gL/gG	aM	BS 88	gL/gG	aM	BS 88	A	
Size S2											
5.5 ... 8	25	10	25	25	10	25	25	10	25	30	--
7 ... 10	32	16	32	32	16	32	32	16	32	40	--
9 ... 12.5	35	16	35	35	16	35	35	16	35	50	--
11 ... 16	40	20	40	40	20	40	40	20	40	60	--
14 ... 20	50	25	50	50	25	50	50	25	50	80	--
18 ... 25	63	32	63	63	32	63	63	32	63	100	3RV13 31-4DC10
22 ... 32	63	35	63	63	35	63	80	35	80	125	3RV13 31-4EC10
28 ... 40	63	50	63	63	50	63	80	50	80	150	3RV13 31-4FC10
36 ... 45	--	--	--	63	50	80	80	50	80	175	3RV13 31-4GC10
40 ... 50	--	--	--	--	--	--	80	50	80	200	3RV13 31-4HC10

Overload relay Setting range	30 kW \cong 3RT10 44			37 kW \cong 3RT10 45			45 kW \cong 3RT10 46			UL-listed fuses RK5	Motor starter protector for starter combinations at $I_q = 50$ kA/400 V AC
	$I_{e\max} = 65$ A (at AC 50 Hz 400 V)			$I_{e\max} = 80$ A (at AC 50 Hz 400 V)			$I_{e\max} = 95$ A (at AC 50 Hz 400 V)				
A	gL/gG	aM	BS 88	gL/gG	aM	BS 88	gL/gG	aM	BS 88	A	
Size S3											
18 ... 25	63	32	63	63	32	63	63	32	63	100	--
22 ... 32	80	35	80	80	35	80	80	35	80	125	--
28 ... 40	80	50	80	80	50	80	80	50	80	150	--
36 ... 50	125	50	125	125	50	125	125	50	125	200	--
45 ... 63	125	63	125	160	63	160	160	63	160	250	3RV13 41-4JC10
57 ... 75	--	--	--	160	80	160	160	80	160	300	3RV13 41-4KC10
70 ... 90	--	--	--	--	--	--	160	100	160	350	3RV13 41-4LC10
80 ... 100	--	--	--	--	--	--	160	100	160	350	3RV13 41-4MC10

For type of coordination "1"¹⁾ see short-circuit protection of the contactors without overload relay under "Controls - Contactors and Contactor Assemblies".

¹⁾ Assignment and short-circuit protective devices according to IEC 60947-4-1:

The contactor or starter must not endanger persons or the installation in the event of a short-circuit.

Type of coordination "1": The contactor or the starter may be non-operational after every short-circuit release.

Type of coordination "2": The contactor or the starter must be operational after a short-circuit release (without replacement of parts). Welding of the contacts is permissible however.

Overload Relays

3RU1 Thermal Overload Relays

3RU11 for standard applications

Characteristic curves

The tripping characteristics show the relationship between the tripping time and tripping current as multiples of the current setting I_e and are given for symmetrical three-pole and two-pole loads from the cold state.

The smallest current used for tripping is called the minimum tripping current. According to IEC 60947-4-1, this current must be within specified limits. The limits of the minimum tripping current for the 3RU11 thermal overload relays for symmetrical three-pole loads are between 105 and 120 % of the current setting.

The tripping characteristic starts with the minimum tripping current and continues with higher tripping currents based on the characteristics of the so-called trip classes (CLASS 10, CLASS 20 etc.). The trip classes describe time intervals within which the overload relays have to trip with 7.2 times the current setting I_e from the cold state for symmetrical three-pole loads.

The tripping times are as follows for:

Trip class	Tripping times
CLASS 10A	2 s ... 10 s
CLASS 10	4 s ... 10 s
CLASS 20	6 s ... 20 s
CLASS 30	9 s ... 30 s

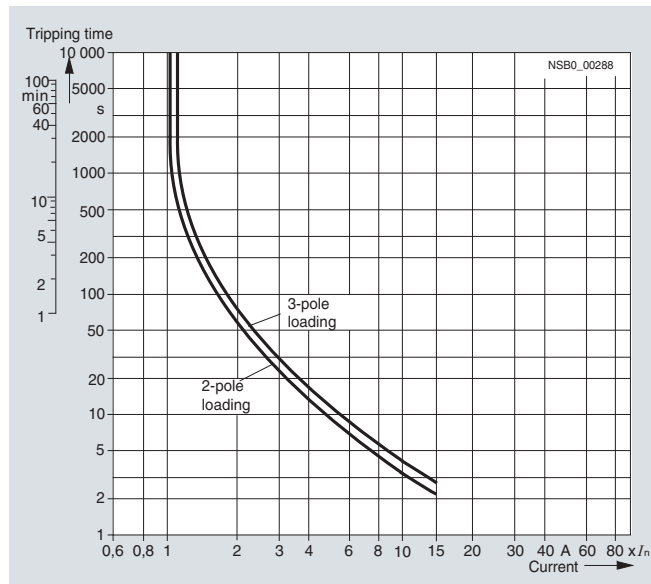

This is the schematic representation of a characteristic curve. The characteristic curves of the individual 3RU11 thermal overload relays can be ordered from "Technical Assistance":

- Either by e-mail to: technical-assistance@siemens.com
- Or on the Internet at: <http://www.siemens.com/automation/service&support>

The tripping characteristic for a three-pole 3RU11 thermal overload relay (see characteristic curve for symmetrical three-pole loads from the cold state) only applies if all three bimetal strips are simultaneously loaded with the same current. If only two bimetal strips are heated due to a phase failure, these two strips alone must generate the necessary force to trigger the tripping mechanism which would result in a longer tripping time or require a higher current. If these higher currents are applied over a longer period, they usually cause damage to the load. To avoid damage, the 3RU11 thermal overload relays are fitted with phase failure sensitivity which ensures faster tripping in accordance with the characteristic curve for 2-pole loads from the cold state by means of a suitable mechanical mechanism.

Compared with a cold load, a load at operating temperature obviously has a lower temperature reserve. This is taken into account by the 3RU11 thermal overload relays by reducing the tripping time to about 25 % when loaded with the current setting I_e for an extended period.

Overload Relays

3RU1 Thermal Overload Relays

3RU11 for standard applications

Dimensional drawings

Screw connection

Lateral distance to grounded components: at least 6 mm.

3RU11 16-..B0

Size S00, with mechanical RESET

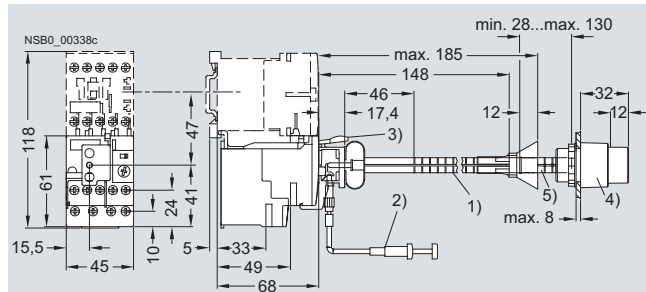

- 1) Mechanical RESET
- 2) Cable release (400 mm or 600 mm long, mounting on the front or laterally on the holder)
- 3) Holder for RESET
- 4) Pushbutton
- 5) Extension plunger

3RU11 16-..B.

Size S00, with terminal bracket for stand-alone installation, with remote RESET

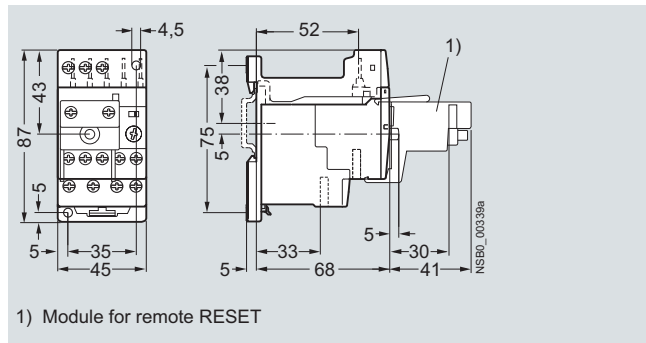

- 1) Module for remote RESET

3RU11 26-..B.

Size S0, with terminal bracket for stand-alone installation

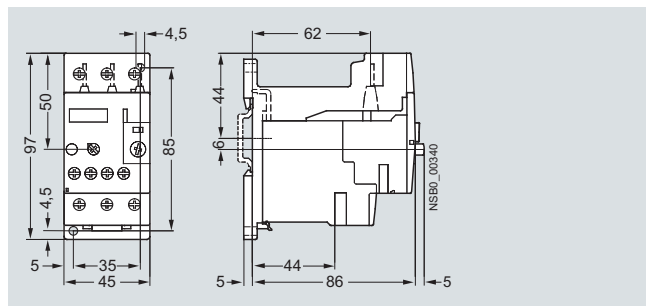

3RU11 36-..B.

Size S2, with terminal bracket for stand-alone installation

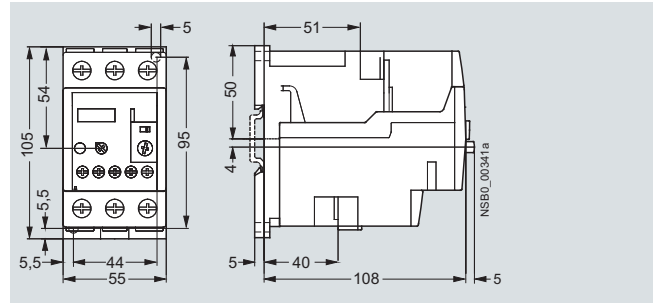

3RU11 46-..B.

Size S3, with terminal bracket for stand-alone installation

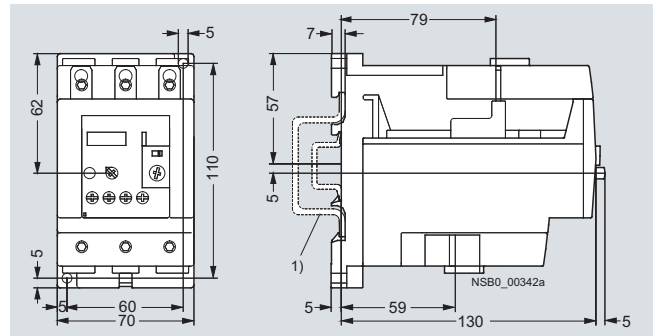

- 1) For mounting on TH 35 - 15 or TH 75 standard mounting rail acc. to EN 60715

Cage Clamp connection

The lateral distance to grounded components must be at least 6 mm.

3RU11 16 -..C1

Size S00, with mechanical RESET (same for sizes S00 to S3).

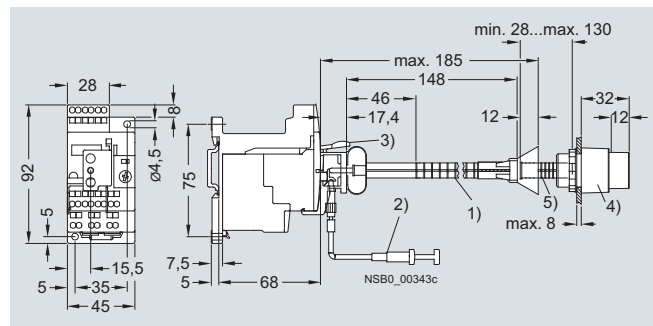

- 1) Mechanical RESET
- 2) Cable release (400 mm or 600 mm long, mounting on the front or laterally on the holder)
- 3) Holder for RESET
- 4) Pushbutton
- 5) Extension plunger

Overload Relays

3RU1 Thermal Overload Relays

3RU11 for standard applications

3RU11 16 -..C1

Size S00, with remote RESET

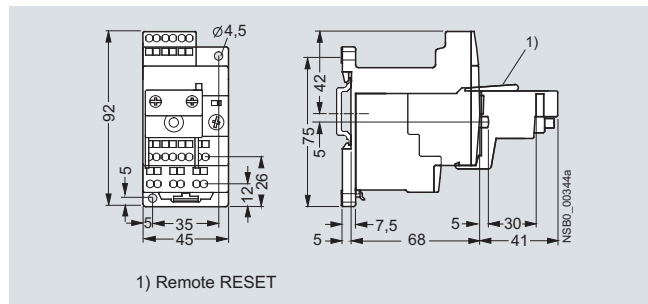

3RU11 26-..D.

Size S0, with terminal bracket for stand-alone installation

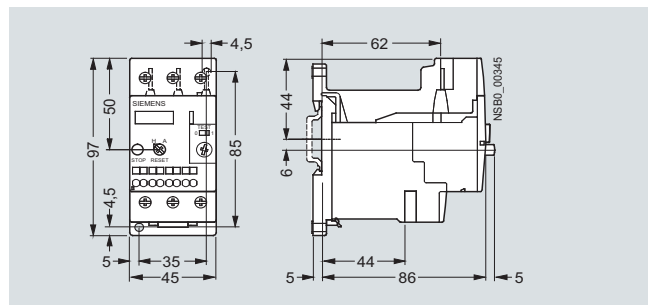

3RU11 36-..D.

Size S2, with terminal bracket for stand-alone installation

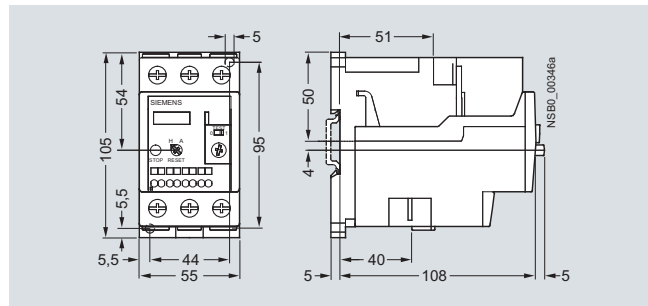

3RU11 46-..D.

Size S3, with terminal bracket for stand-alone installation

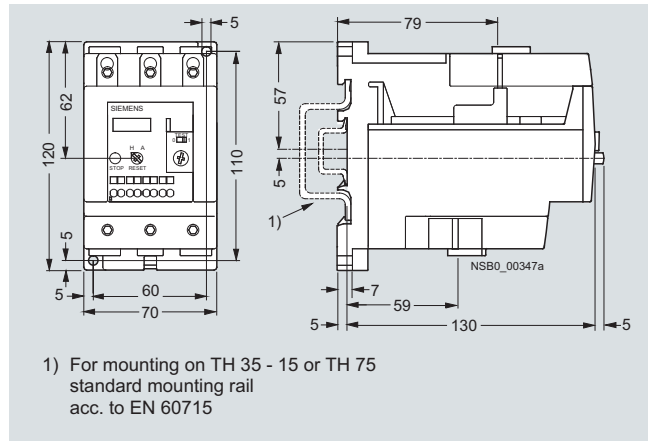

Schematics

3RU11 16

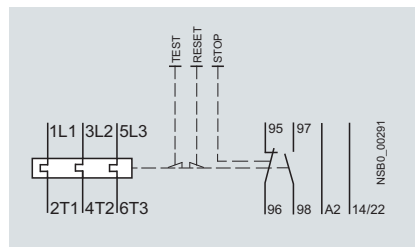

3RU11 26 to 3RU11 46

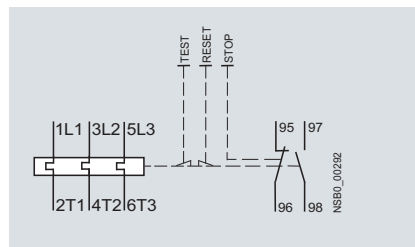

Protection of DC motors

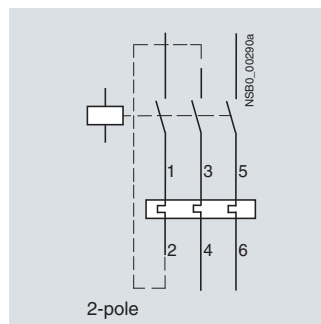
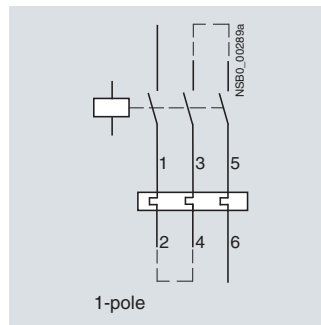

For dimensional drawings of overload relays mounted onto contactors see Contactors and Contactor Assemblies.

Overload Relays

3RU1 Thermal Overload Relays

Accessories

Overview

The following accessories are available for the 3RU11 thermal overload relays:

- For the four overload relay sizes S00 to S3 one terminal bracket each for stand-alone installation
- One electrical remote RESET module in three voltage variants for all sizes
- One mechanical RESET module for all sizes
- One cable release for resetting devices which are difficult to access (for all sizes)
- Terminal covers

Technical specifications

Terminal brackets for stand-alone installation

Type	3RU19 16-3AA01	3RU19 26-3AA01	3RU1 936-3AA01	3RU19 46-3AA01
For overload relays	3RU11 16	3RU11 26	3RU11 36	3RU11 46
Mounting type	For screw and snap-on mounting onto TH 35 standard mounting rails, size S3 also for TH 75 standard mounting rails.			

Connection for main circuit

Connection type	Screw terminals		Screw terminals with box terminal		
	Pozidriv size 2		Allen screw 4 mm		
• Terminal screw					
• Conductor cross-section (min./max.), 1 or 2 conductors					
- Solid	mm ²	1 x (0.5 ... 2.5), max. 1 x (... 4)	1 x (1 ... 6), max. 1 x (... 10)	2 x (0.75 ... 16)	2 x (2.5 ... 16)
- Finely stranded without end sleeve	mm ²	--	--	--	--
- Finely stranded with end sleeve	mm ²	1 x (0.5 ... 2.5)	1 x (1 ... 6)	2 x (0.75 ... 16), 1 x (0.75 ... 25)	2 x (2.5 ... 35), 1 x (2.5 ... 50)
- Stranded	mm ²	1 x (0.5 ... 2.5), max. 1 x (... 4)	1 x (1 ... 6), max. 1 x (... 10)	2 x (0.75 ... 25), 1 x (0.75 ... 35)	2 x (10 ... 50), 1 x (10 ... 70)
- AWG cables, solid or stranded	AWG	1 x (18 ... 14)	1 x (14 ... 10)	2 x (18 ... 3), 1 x (18 ... 1)	2 x (10 ... 1/0), 1 x (10 ... 2/0)
- Ribbon cable conductors (number x width x thickness)	mm	--	--	2 x (6 x 9 x 0.8)	2 x (6 x 9 x 0.8)

Overload Relays

3RB2 Solid-State Overload Relays

3RB20, 3RB21 for standard applications

Overview

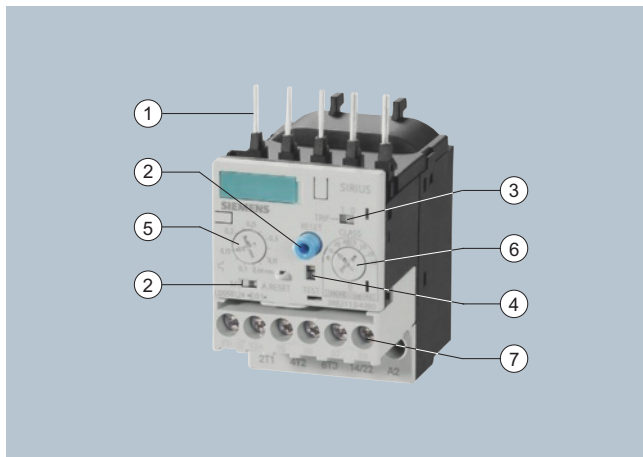

- (1) Connection for mounting onto contactors:
Optimally adapted in electrical, mechanical and design terms to the contactors and soft starters, these connecting pins can be used for direct mounting of the overload relays. Stand-alone installation is possible as an alternative (in some cases in conjunction with a stand-alone installation module).
- (2) Selector switch for manual/automatic RESET and RESET button:
With the slide switch you can choose between manual and automatic RESET. A device set to manual RESET can be reset locally by pressing the RESET button. On the 3RB21 a solid-state remote RESET is integrated.
- (3) Switch position indicator and TEST function of the wiring:
Indicates a trip and enables the wiring test.
- (4) Solid-state test (device test):
Enables a test of all important device components and functions.
- (5) Motor current setting:
Setting the device to the rated motor current is easy with the large rotary knob.
- (6) Trip class setting/internal ground-fault detection (only 3RB21):
Using the rotary switch you can set the required trip class and activate the internal ground-fault detection dependent on the start-up conditions.
- (7) Connecting terminals (removable joint block for auxiliary circuits):
The generously sized terminals permit connection of two conductors with different cross-sections for the main and auxiliary circuits. The auxiliary circuit can be connected with screw terminals and alternatively with spring-type terminals.

The 3RB20 and 3RB21 solid-state overload relays up to 630 A with internal power supply have been designed for inverse-time delayed protection of loads with normal and heavy starting (see "Function") against excessive temperature rises due to overload, phase unbalance or phase failure. An overload, phase unbalance or phase failure result in an increase of the motor current beyond the set rated motor current. This current rise is detected by the current transformers integrated into the devices and evaluated by corresponding solid-state circuits which then output a pulse to the auxiliary contacts. The auxiliary contacts then switch off the load by means of a contactor. The break time depends on the ratio between the tripping current and current setting I_e and is stored in the form of a long-term stable tripping characteristic (see "Characteristic Curves").

In addition to inverse-time delayed protection of loads against excessive temperature rises due to overload, phase unbalance and phase failure, the 3RB21 solid-state overload relays also allow internal ground-fault detection (not possible in conjunction with contactor assemblies for wye-delta starting). This provides protection of loads against high-resistance short-circuits due to damage to the insulation material, moisture, condensed water etc.

The "tripped" status is signaled by means of a switch position indicator. Resetting takes place either manually or automatically after the recovery time has elapsed (see "Function").

The devices are manufactured in accordance with environmental guidelines and contain environmentally friendly and reusable materials. They comply with all important worldwide standards and approvals.

"Increased safety" type of protection EEx e acc. to ATEX directive 94/9/EC

The 3RB20/3RB21 solid-state overload relays are suitable for the overload protection of explosion-proof motors with "increased safety" type of protection EEx e; see Catalog LV 1, Chapter 20 "Appendix" --> "Standards and approvals" --> "Type overview of approved devices for explosion-protected areas (ATEX Explosion Protection)".

Design

Device concept

The 3RB20/3RB21 solid-state overload relays are compact devices, i. e. current measurement (transformer) and the evaluation unit are integrated in a single enclosure.

Mounting options

The 3RB20/3RB21 solid-state overload relays are suitable for direct and space-saving mounting onto 3RT1 contactors and 3RW30/3RW31 soft starters as well as for stand-alone installation.

For more information on the mounting options see "Technical specifications" and Catalog LV 1, "Selection and ordering data".

Connection methods

Main circuit

All sizes of the 3RB20/3RB21 solid-state overload relays can be connected with screw terminals. As an alternative for sizes S3 to S10/S12, the main current paths can be connected with the help of rails. Sizes S2 to S6 of the 3RB20/3RB21 relays are also available with a straight-through transformer. In this case, the cables of the main circuit are routed directly through the feed-through openings of the relay to the contactor terminals.

Auxiliary circuit

Connection of the auxiliary circuit (removable terminal block) is possible with either screw or spring-type terminal connection system (special device variants).

For more information on the connection options see "Technical specifications" and Catalog LV 1, "Selection and ordering data".

Overload relays in contactor assemblies for wye-delta starting

When overload relays are used in combination with contactor assemblies for wye-delta starting it must be noted that only 0.58 times the motor current flows through the line contactor. An overload relay mounted onto the line contactor must be set to 0.58 times the motor current.

An assignment of the 3RB20 solid-state overload relays to the line contactors of our 3RA contactor assemblies for wye-delta starting can be found in Chapter 3 "Controls: Contactors and Contactor Assemblies".

When 3RB21 solid-state overload relays are used in combination with contactor assemblies for wye-delta starting, the internal ground-fault detection must not be activated.

Operation with frequency converter

The 3RB20/3RB21 solid-state overload relays are suitable for frequencies of 50/60 Hz and the associated harmonics. This permits the 3RB20/3RB21 overload relays to be used on the input side of the frequency converter.

If motor protection is required on the outgoing side of the frequency converter, Siemens recommends the 3RN thermistor motor protection devices or the 3RU11 thermal overload relays for this purpose.

Overload Relays

3RB2 Solid-State Overload Relays

3RB20, 3RB21 for standard applications

Function

Basic functions

The 3RB20/3RB21 solid-state overload relays are designed for:

- Inverse-time delayed protection of loads from overloading
- Inverse-time delayed protection of loads from phase unbalance
- Inverse-time delayed protection of loads from phase failure
- Protection of loads from high-resistance short-circuits (internal ground-fault detection only with 3RB21).

Control circuit

The 3RB20/3RB21 solid-state overload relays have an internal power supply, i. e. no additional supply voltage is required.

Short-circuit protection

Fuses or motor starter protectors must be used for short-circuit protection.

For assignments of the corresponding short-circuit protection devices to the 3RB20/3RB21 solid-state overload relays with/without contactor see "Technical specifications" and Catalog LV 1, "Selection and ordering data".

Trip classes

The 3RB20 solid-state overload relays are available for normal starting conditions with trip CLASS 10 or for heavy starting conditions with trip CLASS 20 (fixed setting in each case).

The 3RB21 solid-state overload relays are suitable for normal and heavy starting conditions. The required trip class (CLASS 5, 10, 20 or 30) can be adjusted by means of a rotary switch depending on the current start-up condition.

For details of the trip classes see "Characteristic Curves".

Phase failure protection

The 3RB20/3RB21 solid-state overload relays are fitted with phase failure protection (see "Characteristic Curves") in order to minimize temperature rises of the load during single-phase operation.

Phase failure protection is not effective for loads with star-connection and a grounded neutral point or a neutral point which is connected to a neutral conductor.

Setting

The 3RB20/3RB21 solid-state overload relays are set to the rated motor current by means of a rotary knob. The scale of the rotary knob is shown in ampere.

With the 3RB21 solid-state overload relay it is also possible to select the trip class (CLASS 5, 10, 20 or 30) using a second rotary knob and to switch the internal ground-fault detection on and off.

Manual and automatic reset

In the case of the 3RB20/3RB21 solid-state overload relays, a slide switch can be used to choose between automatic and manual resetting.

If manual reset is set, a reset can be carried out directly on the device after a trip by pressing the blue RESET button. Resetting is possible in combination with mechanical and mechanical reset options from the range of accessories (see Catalog LV 1, "Accessories"). As an alternative to the mechanical RESET options, the 3RB21 solid-state overload relays can be equipped with electrical remote RESET by applying a voltage of 24 V DC to the terminals A3 and A4.

If the slide switch is set to automatic RESET, the relay is reset automatically.

The time between tripping and resetting is determined by the recovery time.

Recovery time

With the 3RB20/3RB21 solid-state overload relays the recovery time after inverse-time delayed tripping is 3 minutes when automatic RESET is set. This recovery time allows the load to cool down.

If the button is set to manual RESET and automatic RESET, the 3RB20/3RB21 devices can be reset immediately after tripping.

TEST function

With motor current flowing, the TEST button can be used to check whether the relay is working correctly (device/solid-state test). Current measurement, motor model and trip unit are tested. If these components are OK, the device is tripped according to the table below. If there is an error, no tripping takes place.

Trip classes	Required loading with the rated current prior to pressing the TEST button	Tripping within
CLASS 5	3 min	30 s
CLASS 10	5 min	1 min
CLASS 20	10 min	2 min
CLASS 30	15 min	3 min

Note: The TEST button must be kept pressed throughout the test. In this case the motor current must be equal to more than 80 % of the current setting I_e and have at least the value of the lower current setting.

Testing of the auxiliary contacts and the control current wiring is possible with the switch position indicator slide. Actuating the slide simulates tripping of the relay. During this simulation the NC contact (95-96) is opened and the NO contact (97-98) is closed. This tests whether the auxiliary circuit has been correctly wired.

After a test trip the relay is reset by pressing the RESET button.

Self-monitoring

The 3RB20/3RB21 solid-state overload relays have a self-monitoring feature, i. e. the devices constantly monitor their own basic functions and trip if an internal fault is detected.

Display of operating state

The respective operating state of the 3RB20/3RB21 solid-state overload relays is displayed by means of the position of the marking on the switch position indicator slide. After tripping due to overload, phase failure, phase unbalance or ground fault (ground-fault detection possible only with 3RB21) the marking on the slide is to left on the "O" mark, otherwise it is on the "I" mark.

Auxiliary contacts

The 3RB20/3RB21 solid-state overload relays are fitted with an NO contact for the "tripped" signal, and an NC contact for switching off the contactor.

Overload Relays

3RB2 Solid-State Overload Relays

3RB20, 3RB21 for standard applications

Technical specifications

Type	3RB20 16, 3RB21 13	3RB20 26, 3RB21 23	3RB20 36, 3RB21 33	3RB20 46, 3RB21 43	3RB20 56, 3RB21 53	3RB20 66, 3RB21 63
Size	S00	S0	S2	S3	S6	S10/S12
Width	45 mm	45 mm	55 mm	70 mm	120 mm	145 mm
General data						
Trips in the event of	Overload, phase failure, and phase unbalance + ground fault (for 3RB21 only)					
Trip class acc. to IEC 60947-4-1	CLASS 10/20/5, 10, 20 and 30 adjustable (depending on the version)					
Phase failure sensitivity	Yes					
Overload warning	No					
Reset and recovery	Manual, automatic and remote RESET (depending on the version)					
• Reset options after tripping						
• Recovery time						
- For automatic RESET	min.	Approx. 3 min				
- For manual RESET	min.	Immediately				
- For remote RESET	min.	Immediately				
Features						
• Display of operating state on device	Yes, by means of switch position indicator slide					
• TEST function	Yes, test of electronics by pressing the TEST button / test of auxiliary contacts and wiring of control circuit by actuating the switch position indicator slide / self-monitoring					
• RESET button	Yes					
• STOP button	No					
Explosion protection – safe operation of motors with "increased safety" type of protection						
EC type test certificate number acc. to directive 94/9/EC (ATEX)	PTB 06 ATEX 3001 ⚠ II (2) GD					
Ambient temperatures						
• Storage/transport	°C	-40 ... +80				
• Operation	°C	-25 ... +60				
• Temperature compensation	°C	+60				
• Permissible rated current at						
- Temperature inside control cabinet 60 °C, stand-alone installation	%	100	100 ²⁾	100	100	100 or 90 ³⁾
- Temperature inside control cabinet 60 °C, mounted on contactor	%	100	100 ²⁾	100	100	70
- Temperature inside control cabinet 70 °C	%	1)				
Repeat terminals						
• Coil repeat terminal	Yes		Not required			
• Auxiliary contact repeat terminal	Yes		Not required			
Degree of protection acc. to IEC 60529	IP20		IP20 ⁴⁾			
Touch protection acc. to IEC 61140	Finger-safe				Finger-safe, for busbar connection with cover	Finger-safe with cover
Shock resistance with sine acc. to IEC 60068-2-27	<i>g</i> /ms	15/11 ⁵⁾				
Electromagnetic compatibility (EMC) – Interference immunity						
• Conductor-related interference						
- Burst acc. to IEC 61000-4-4 (corresponds to degree of severity 3)	kV	2 (power ports), 1 (signal ports)				
- Surge acc. to IEC 61000-4-5 (corresponds to degree of severity 3)	kV	2 (line to earth), 1 (line to line)				
• Electrostatic discharge acc. to IEC 61000-4-2 (corresponds to degree of severity 3)	kV	8 (air discharge), 6 (contact discharge)				
• Field-related interference acc. to IEC 61000-4-3 (corresponds to degree of severity 3)	V/m	10				
Electromagnetic compatibility (EMC) – Emitted interference	Degree of severity B acc. to EN 55011 (CISPR 11) and EN 55022 (CISPR 22)					
Resistance to extreme climates – air humidity	%	100				
Dimensions	See dimensional drawings					
Installation altitude above sea level	m	Up to 2000				
Mounting position	Any					
Type of mounting	Direct mounting/stand-alone installation with terminal bracket			Direct mounting/stand-alone installation		

1) On request.

2) S0 for 6 ... 25 A, CLASS 20, $I_{\text{emax}} = 19 \text{ A}$;
S0 for 6 ... 25 A, CLASS 30, $I_{\text{emax}} = 16 \text{ A}$.

3) 90 % for relay with current setting range 160 ... 630 A.

4) Terminal compartment: degree of protection IP00.

5) Signaling contact 97/98 in position "tripped": 4/11 *g*/ms.

Overload Relays

3RB2 Solid-State Overload Relays

3RB20, 3RB21 for standard applications

Type		3RB20 16, 3RB21 13	3RB20 26, 3RB21 23	3RB20 36, 3RB21 33	3RB20 46, 3RB21 43
Size		S00	S0	S2	S3
Width		45 mm	45 mm	55 mm	70 mm
Main circuit					
Rated insulation voltage U_i (degree of pollution 3)	V	690		690/1000 ¹⁾	1000
Rated impulse withstand voltage U_{imp}	kV	6		6/8 ²⁾	8
Rated operational voltage U_e	V	690		690/1000 ¹⁾	1000
Type of current		No			
• Direct current		Yes, 50/60 Hz $\pm 5\%$			
• Alternating current					
Current setting	A	0.1 ... 0.4 to 3 ... 12	0.1 ... 0.4 to 6 ... 25	6 ... 25 and 12.5 ... 50	12.5 ... 50 and 25 ... 100
Power loss per unit (max.)	W	0.05			
Short-circuit protection		See Catalog LV 1, "Selection and ordering data" See "Technical specifications" (short-circuit protection with fuses for motor feeders)			
• With fuse without contactor					
• With fuse and contactor					
Protective separation between main and auxiliary conducting path acc. to IEC 60947-1 (degree of pollution 2)	V	690 ³⁾			
Connection for main circuit					
Connection type		 Screw terminals with box terminal			
• Terminal screw		Pozidriv size 2			
• Tightening torque	Nm	0.8 ... 1.2	2 ... 2.5	3 ... 4.5	Allen screw 4 mm 4 ... 6
• Conductor cross-sections (min./max.), 1 or 2 conductors					
- Solid	mm ²	2 × (0.5 ... 1.5) ⁴⁾ 2 × (0.75 ... 2.5) ⁴⁾	2 × (1 ... 2.5) ⁴⁾ 2 × (2.5 ... 6) ⁴⁾	2 × (1 ... 16)	2 × (2.5 ... 16)
- Finely stranded without end sleeve	mm ²	--			
- Finely stranded with end sleeve	mm ²	2 × (0.5 ... 1.5) ⁴⁾ 2 × (0.75 ... 2.5) ⁴⁾	2 × (1 ... 2.5) ⁴⁾ 2 × (2.5 ... 6) ⁴⁾	2 × (1 ... 16) ⁴⁾ 1 × (1 ... 25) ⁴⁾	2 × (2.5 ... 35), 1 × (2.5 ... 50)
- Stranded	mm ²	--		2 × (max. 25), 1 × (1 ... 35)	2 × (10 ... 50), 1 × (10 ... 70)
- AWG cables, solid or stranded	AWG	2 × (18 ... 14)	2 × (14 ... 10)	2 × (max. 4), 1 × (18 ... 2)	2 × (10 ... 1/0), 1 × (10 ... 2/0)
- Ribbon cable conductors (number x width x thickness)	mm	--		2 × (6 × 9 × 0.8)	2 × (6 × 9 × 0.8)
Busbar connections					
• Terminal screw		--			
• Tightening torque	Nm	--			
• Conductor cross-section (min./max.)		--			
- Finely stranded with cable lug	mm ²	--			
- Stranded with cable lug	mm ²	--			
- AWG cable, solid or stranded, with cable lug	AWG	--			
- With connecting bar (max. width)	mm	--			
Straight-through transformers					
Diameter of opening	mm	--		15	18

1) For version with straight-through transformer up to 1000 V AC.

2) For version with straight-through transformer up to 8 kV.

3) For grounded networks, otherwise 600 V.

4) If two different conductor cross-sections are connected to one clamping point, both cross-sections must lie in the range specified. If identical cross-sections are used, this restriction does not apply.

Overload Relays

3RB2 Solid-State Overload Relays

3RB20, 3RB21 for standard applications

Type		3RB20 56, 3RB21 53	3RB20 66, 3RB21 63
Size		S6	S10/S12
Width		120 mm	145 mm
Main circuit			
Rated insulation voltage U_i (degree of pollution 3)	V	1000	
Rated impulse withstand voltage U_{imp}	kV	8	
Rated operational voltage U_e	V	1000	
Type of current		No	
• Direct current		No	
• Alternating current		Yes, 50/60 Hz $\pm 5\%$	
Current setting	A	50 ... 200	55 ... 250 to 160 ... 630
Power loss per unit (max.)	W	0.05	
Short-circuit protection			
- With fuse without contactor		See Catalog LV 1, "Selection and ordering data"	
- With fuse and contactor		See "Technical specifications" (short-circuit protection with fuses for motor feeders)	
Protective separation between main and auxiliary conducting path acc. to IEC 60947-1 (degree of pollution 2)	V	690 ¹⁾	
Connection for main circuit			
Connection type			
 Screw terminals with box terminal			
• Terminal screw		4 mm Allen screw	5 mm Allen screw
• Tightening torque	Nm	10 ... 12	20 ... 22
• Conductor cross-sections (min./max.), 1 or 2 conductors			
- Solid	mm ²	--	
- Finely stranded without end sleeve	mm ²	With 3RT19 55-4G box terminal: 2 × (1 × max. 50, 1 × max. 70), 1 × (10 ... 70) With 3RT19 56-4G box terminal: 2 × (1 × max. 95, 1 × max. 120), 1 × (10 ... 120)	2 × (50 ... 185), Front clamping point only: 1 × (70 ... 240) Rear clamping point only: 1 × (120 ... 185)
- Finely stranded with end sleeve	mm ²	With 3RT19 55-4G box terminal: 2 × (1 × max. 50, 1 × max. 70), 1 × (10 ... 70) With 3RT19 56-4G box terminal: 2 × (1 × max. 95, 1 × max. 120), 1 × (10 ... 120)	2 × (50 ... 185), Front clamping point only: 1 × (70 ... 240) Rear clamping point only: 1 × (120 ... 185)
- Stranded	mm ²	With 3RT19 55-4G box terminal: 2 × (max. 70), 1 × (16 ... 70) With 3RT19 56-4G box terminal: 2 × (max. 120), 1 × (16 ... 120)	2 × (70 ... 240), Front clamping point only: 1 × (95 ... 300) Rear clamping point only: 1 × (120 ... 240)
- AWG cables, solid or stranded	AWG	With 3RT19 55-4G box terminal: 2 × (max. 1/0), 1 × (6 ... 2/0) With 3RT19 56-4G box terminal: 2 × (max. 3/0), 1 × (6 ... 250 kcmil)	2 × (2/0 ... 500 kcmil), Front clamping point only: 1 × (3/0 ... 600 kcmil) Rear clamping point only: 1 × (250 kcmil ... 500 kcmil)
- Ribbon cable conductors (number x width x thickness)	mm	With 3RT19 55-4G box terminal: 2 × (6 × 15.5 × 0.8), 1 × (3 × 9 × 0.8 ... 6 × 15.5 × 0.8) With 3RT19 56-4G box terminal: 2 × (10 × 15.5 × 0.8), 1 × (3 × 9 × 0.8 ... 10 × 15.5 × 0.8)	2 × (20 × 24 × 0.5), 1 × (6 × 9 × 0.8 ... 20 × 24 × 0.5)
Connection type			
Busbar connections			
• Terminal screw		M 8 × 25	M 10 × 30
• Tightening torque	Nm	10 ... 14	14 ... 24
• Conductor cross-section (min./max.)			
- Finely stranded with cable lug	mm ²	16 ... 95 ²⁾	50 ... 240 ³⁾
- Stranded with cable lug	mm ²	25 ... 120 ²⁾	70 ... 240 ³⁾
- AWG cable, solid or stranded, with cable lug	AWG	4 ... 250 kcmil	2/0 ... 500 kcmil
- With connecting bar (max. width)	mm	15	25
Connection type			
Straight-through transformers			
Diameter of opening	mm	24.5	--

¹⁾ For grounded networks, otherwise 600 V.



²⁾ When connecting cable lugs according to DIN 46235, use the 3RT19 56-4EA1 terminal cover for conductor cross-sections from 95 mm² to ensure phase spacing.

³⁾ When connecting cable lugs according to DIN 46234 for conductor cross-sections from 240 mm² as well as DIN 46235 for conductor cross-sections from 185 mm², use the 3RT19 56-4EA1 terminal cover to ensure phase spacing.

Overload Relays

3RB2 Solid-State Overload Relays

3RB20, 3RB21 for standard applications

Type	3RB20 16, 3RB21 13	3RB20 26, 3RB21 23	3RB20 36, 3RB21 33	3RB20 46, 3RB21 43	3RB20 56, 3RB21 53	3RB20 66, 3RB21 63
Size	S00	S0	S2	S3	S6	S10/S12
Width	45 mm	45 mm	55 mm	70 mm	120 mm	145 mm
Auxiliary circuit						
Number of NO contacts	1					
Number of NC contacts	1					
Auxiliary contacts – assignment	1 NO for the signal "tripped", 1 NC for disconnecting the contactor					
Rated insulation voltage U_i (degree of pollution 3)	V	300				
Rated impulse withstand voltage U_{imp}	kV	4				
Auxiliary contacts – contact rating						
• NC contact with alternating current AC-14/AC-15 Rated operational current I_e at U_e :						
- 24 V	A	4				
- 120 V	A	4				
- 125 V	A	4				
- 250 V	A	3				
• NO contact with alternating current AC-14/AC-15: Rated operational current I_e at U_e :						
- 24 V	A	4				
- 120 V	A	4				
- 125 V	A	4				
- 250 V	A	3				
• NC, NO contact with direct current DC-13: Rated operational current I_e at U_e :						
- 24 V	A	2				
- 60 V	A	0.55				
- 110 V	A	0.3				
- 125 V	A	0.3				
- 250 V	A	0.11				
• Conventional thermal current I_{th}	A	5				
• Contact reliability (suitability for PLC control; 17 V, 5 mA)		Yes				
Short-circuit protection						
• With fuse, gL/gG operational class	A	6				
Ground-fault protection (only 3RB21)						
• Tripping value I_{Δ}	The information refers to sinusoidal residual currents at 50/60 Hz > $0.75 \times I_{motor}$					
• Operating range I	Lower current setting value < I_{motor} < $3.5 \times$ upper current setting value					
• Response time t_{rip} (in steady-state condition)	s	< 1				
Integrated electrical remote reset (only 3RB21)						
Connecting terminals A3, A4	24 V DC, 100 mA, 2.4 W short-term					
Protective separation between main and auxiliary conducting path acc. to IEC 60947-1	V	300				
CSA, UL, UR rated data						
Auxiliary circuit – switching capacity	B300, R300					
Connection of the auxiliary circuit						
Connection type						
 Screw terminals						
• Terminal screw	Pozidriv size 2					
• Tightening torque	Nm	0.8 ... 1.2				
• Conductor cross-sections (min./max.), 1 or 2 conductors						
- Solid	mm ²	1 × (0.5 ... 4), 2 × (0.5 ... 2.5)				
- Finely stranded without end sleeve	mm ²	–				
- Finely stranded with end sleeve	mm ²	1 × (0.5 ... 2.5), 2 × (0.5 ... 1.5)				
- Stranded	mm ²	–				
- AWG cables, solid or stranded	AWG	2 × (20 ... 14)				
Connection type						
 Spring-type terminals						
• Conductor cross-sections (min./max.), 1 or 2 conductors						
- Solid	mm ²	2 × (0.25 ... 1.5)				
- Finely stranded without end sleeve	mm ²	–				
- Finely stranded with end sleeve	mm ²	2 × (0.25 ... 1.5)				
- Stranded	mm ²	2 × (0.25 ... 1.5)				
- AWG cables, solid or stranded	AWG	2 × (24 ... 16)				

Footnotes for page 5/76:
¹⁾ Please observe operational voltage.

²⁾ Type of coordination and short-circuit protective devices acc. to IEC 60947-4-1:
Type of coordination "1": The contactor or the starter may be non-operational after every short-circuit release.

Type of coordination "2": The contactor or the starter must be operational after a release (without replacement of parts). There is a risk of contact welding.

³⁾ $U_e = 500$ V.

⁴⁾ Contactor cannot be mounted.

⁵⁾ Please ensure that the maximum AC-3 operational current has sufficient safety clearance from the rated current of the fuses.

⁶⁾ With 3UF18 68-3GA00 current transformer.

Overload Relays

3RB2 Solid-State Overload Relays

3RB20, 3RB21 for standard applications

Short-circuit protection with fuses for motor feeders

For short-circuit currents up to 50 kA or 100 kA
at rated operational voltages up to 690 V

Overload relays	Contactors	CLASS 5 and 10			CLASS 20			CLASS 30			690 V/ 50 kA		690 V/ 100 kA		690 V/ 50 kA		415 V/ 50 kA	600 V/ SSCR
		Fuses ¹⁾																
											LV HRC		Type 3NA		Type 3ND		Acc. to BS 88	Listed acc. to UL, RK5 CL. L
											DIAZED		Type 3SB					
											NEOZED		Type 3SE					
		Operational class gG																
		aM																
Setting range	Type	Rated operational current I_e /AC-3 in A at ... V									Rated operational current I_e /AC-3 in A for type of coordination ²⁾							
A		400	500	690	400	500	690	400	500	690	1	2	1	2	2	2	--	
Size S00																		
0.1 ... 0.4	3RT10 15	0.4	0.4	0.4	0.4	0.4	0.4	0.4	0.4	0.4	35	1 ³⁾	20	1 ³⁾	--	--	1.6	
0.32 ... 1.25	3RT10 15	1.25	1.25	1.25	1.25	1.25	1.25	1.25	1.25	1.25	35	2	20	2	--	2	5	
1 ... 4	3RT10 15	4	4	4	4	4	4	4	4	4	35	10	20	10	--	10	15	
	3RT10 16	4	4	4	4	4	4	4	4	4	35	10	20	10	--	10	15	
	3RT10 17	4	4	4	4	4	4	4	4	4	35	10	20	10	--	10	15	
3 ... 12	3RT10 16	9	6.5	5.2	9	6.5	5.2	9	6.5	5.2	35	20	20	20	--	20	45	
	3RT10 17	12	9	6.3	10	9	6.3	9	9	6.3	35	20	20	20	--	20	45	
Size S0																		
0.1 ... 0.4	3RT10 23	0.4	0.4	0.4	0.4	0.4	0.4	0.4	0.4	0.4	35	1 ³⁾	20	1 ³⁾	--	--	1.6	
0.32 ... 1.25	3RT10 23	1.25	1.25	1.25	1.25	1.25	1.25	1.25	1.25	1.25	35	2	20	2	--	2	5	
1 ... 4	3RT10 23	4	4	4	4	4	4	--	--	--	63	10	20	10	--	10	15	
	3RT10 24	4	4	4	4	4	4	4	4	4	63	10	25	10	--	10	15	
3 ... 12	3RT10 23	9	6.5	5.2	9	6.5	5.2	--	--	--	63	25	20	20	--	20	45	
	3RT10 24	12	12	9	12	12	9	12	12	9	63	25	25	20	20	20	45	
	3RT10 25	12	12	12	12	12	12	12	12	12	63	25	25	20	20	20	45	
6 ... 25	3RT10 24	12	12	9	12	12	9	12	12	9	63	25	25	25	20	25	70	
	3RT10 25	17	17	13	16	16	13	14	14	13	63	25	25	25	20	25	70	
	3RT10 26	25	18	13	16	16	13	14	14	13	100	35	35	35	20	25	100	
Size S2																		
6 ... 25	3RT10 34	25	25	20	22.3	22.3	20	19.1	19.1	19.1	125	63	63	63	50	63	100	
	3RT10 35	25	25	24	25	25	24	25	25	24	125	63	63	63	50	80	100	
12.5 ... 50	3RT10 34	32	32	20	22.3	22.3	20	19.1	19.1	19.1	125	63	63	63	50	63	125	
	3RT10 35	40	40	24	29.4	29.4	24	26.5	26.5	24	125	63	63	63	50	80	150	
	3RT10 36	50	50	24	32.7	32.7	24	26.5	26.5	24	160	80	80	80	50	80	200	
Size S3																		
12.5 ... 50	3RT10 44	50	50	47	49	49	47	41.7	41.7	41.7	200	125	125	125	63	125	200	
	3RT10 45	50	50	50	50	50	50	45	45	45	200	160	160	160	80	160	200	
25 ... 100	3RT10 44	65	65	47	49	49	47	41.7	41.7	41.7	200	125	125	125	63	125	250	
	3RT10 45	80	80	58	53	53	53	45	45	45	200	160	160	160	80	160	300	
	3RT10 46	95	95	58	59	59	58	50	50	50	200	160	160	160	100	160	350	
	3RT10 54	100	100	100	81.7	81.7	81.7	69	69	69	355	315	315	315	160	250	400	
	3RT10 55	--	--	--	100	100	100	90	90	90	355	315	315	315	200	315	400	
Size S6																		
50 ... 200	3RT10 54	115	115	115	81.7	81.7	81.7	69	69	69	355	315	315	315	160	250	450	
	3RT10 55	150	150	150	107	107	107	90	90	90	355	315	315	315	200	315	500	
	3RT10 56	185	185	170	131	131	131	111	111	111	355	315	315	315	200	315	500	
Size S10																		
55 ... 250	3RT10 64	225	225	225	160	160	160	135	135	135	500	400	400	400	250	400	600	
	3RT10 65	250	250	250	188	188	188	159	159	159	500	400	400	400	315	400	700	
	3RT10 66	250	250	250	213	213	213	180	180	180	500	400	400	400	315	400	700	
Size S12																		
160 ... 630	3RT10 64	225	225	225	160	160	160	--	--	--	500	400	400	400	250	400	600	
	3RT10 65	265	265	265	188	188	188	--	--	--	500	400	400	400	315	400	700	
	3RT10 66	300	300	280	213	213	213	180	180	180	500	400	400	400	315	400	800	
	3RT10 75	400	400	400	284	284	284	240	240	240	630	500	500	500	400	450	1000	
	3RT10 76	500	500	450	355	355	355	300	300	300	630	500	500	500	500	500	1200	
	3RT12 64	225	225	225	225	225	225	173	173	173	500	500	500	500	400	450	600	
	3RT12 65	265	265	265	265	265	265	204	204	204	500	500	500	500	400	450	700	
	3RT12 66	300	300	300	300	300	300	231	231	231	500	500	500	500	400	450	800	
	3RT12 75	400	400	400	400	400	400	316	316	316	800	800	800	--	630	800	1000	
	3RT12 76	500	500	500	500	500	500	385	385	385	800	800	800	--	630	800	1200	
	3TF68 ⁴⁾	630	630	630	440	440	440	376	376	376	800	630 ⁵⁾	630 ⁵⁾	630 ⁵⁾	630	500	1600	
	3TF69 ⁴⁾	630	630	630	572	572	572	500	500	500	800	630 ⁵⁾	630 ⁵⁾	--	630	630	1600	
	Size 14																	
0.32 ... 1.25 ⁶⁾	3TF69 ⁴⁾	820	820	820	572	572	572	500	500	500	800	630 ⁵⁾	630 ⁵⁾	--	630	630	1600	

For footnotes see page 5/75.

SSCR = Standard Short-Circuit Rating

Overload Relays

3RB2 Solid-State Overload Relays

3RB20, 3RB21 for standard applications

Characteristic curves

The tripping characteristics show the relationship between the tripping time and tripping current as multiples of the current setting I_e and are given for symmetrical three-pole and two-pole loads from the cold state.

The smallest current used for tripping is called the minimum tripping current. According to IEC 60947-4-1, this current must be within specified limits. The limits of the total tripping current for the 3RB20/3RB21 solid-state overload relays for symmetrical three-pole loads are between 105 and 120 % of the current setting.

The tripping characteristic starts with the minimum tripping current and continues with higher tripping currents based on the characteristics of the so-called trip classes (CLASS 10, CLASS 20 etc.). The trip classes describe time intervals within which the overload relays have to trip with 7.2 times the current setting I_e from the cold state for symmetrical three-pole loads.

The tripping times according to IEC 60947-4-1, tolerance band E, are as follows for:

Trip class	Tripping time
CLASS 5	3 ... 5 s
CLASS 10	5 ... 10 s
CLASS 20	10 ... 20 s
CLASS 30	20 ... 30 s

The tripping characteristic for a three-pole overload relay from the cold state (see illustration 1) only apply if all three phases are simultaneously loaded with the same current. In the event of a phase failure the 3RB20/3RB21 solid-state overload relays switch off the contactor more quickly in order to minimize heating of the load in accordance with the tripping characteristic for two-pole loads from the cold state (see illustration 2). With phase unbalance the devices switch off depending on the degree of the unbalance between the two characteristic curves.

Compared with a cold load, a load at operating temperature obviously has a lower temperature reserve. The tripping time of the 3RB20/3RB21 solid-state overload relays is reduced therefore to about 20 % when loaded with the current setting I_e for an extended period.

Tripping characteristics for 3-pole loads

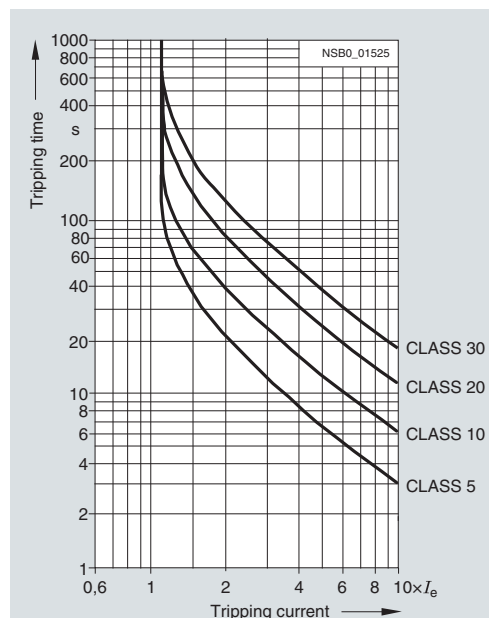

Illustration 1

Tripping characteristics for 2-pole loads

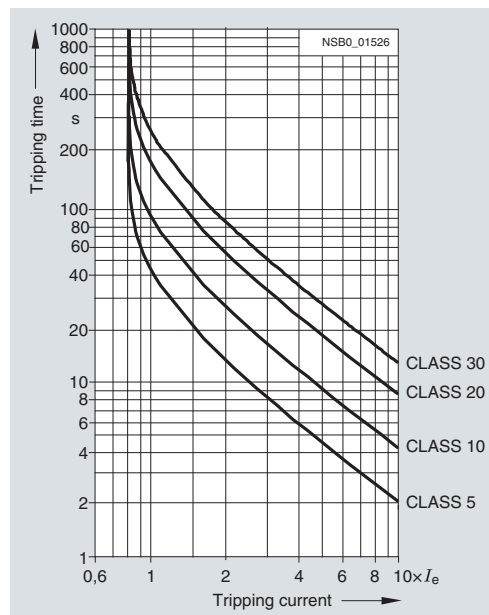

Illustration 2

The above illustrations are schematic representations of characteristic curves. The characteristic curves of the individual 3RB20/3RB21 electronic overload relays can be ordered from "Technical Assistance":

- Either by e-mail to: technical-assistance@siemens.com
- Or on the Internet at: <http://www.siemens.com/automation/service&support>

Overload Relays

3RB2 Solid-State Overload Relays

3RB20, 3RB21 for standard applications

Dimensional drawings

3RB20 16, 3RB21 13, size S00

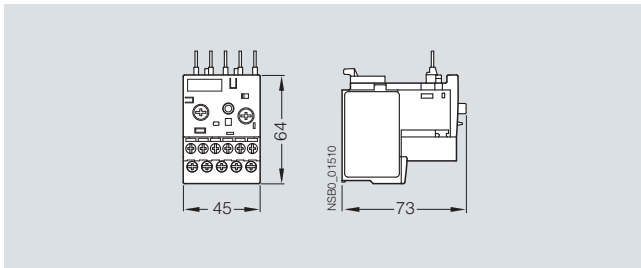

3RB20 36, 3RB21 33, size S2

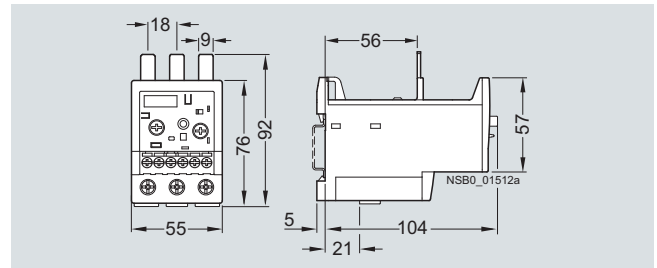

3RB20 16, 3RB21 13, size S00, stand-alone installation

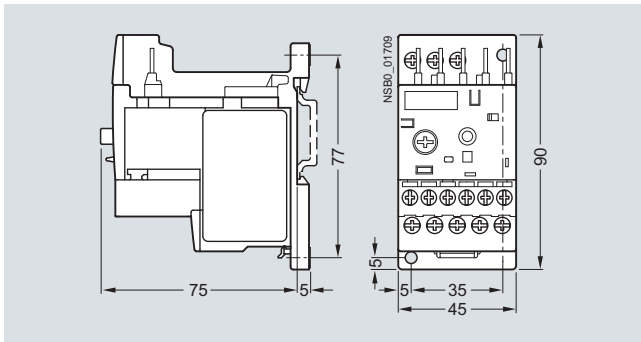

3RB20 46, 3RB21 43, size S3

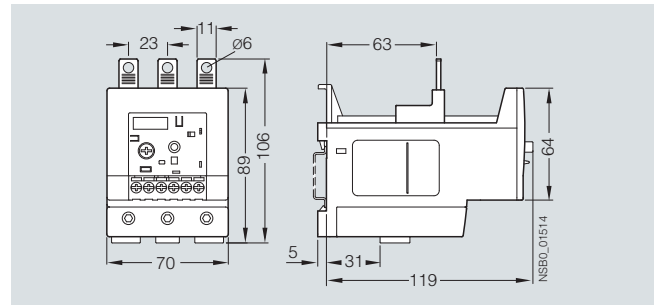

3RB20 26, 3RB21 23, size S0

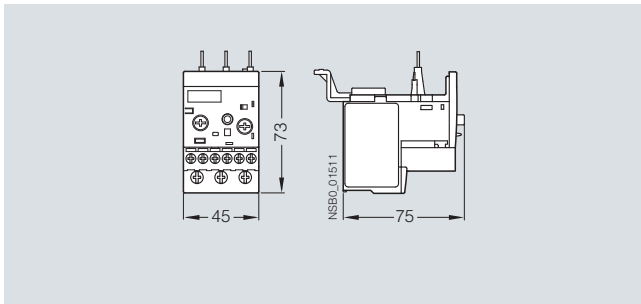

3RB20 56, 3RB21 53, size S6

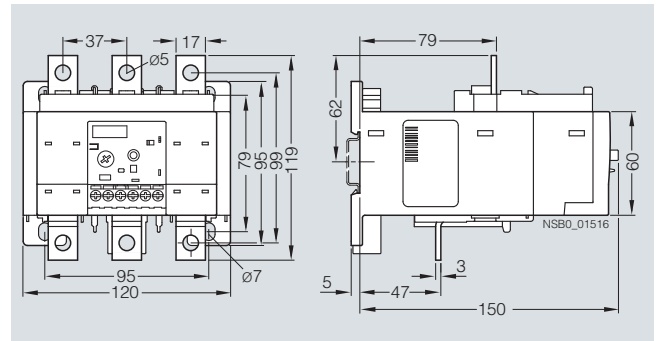

3RB20 26, 3RB21 23, size S0, stand-alone installation

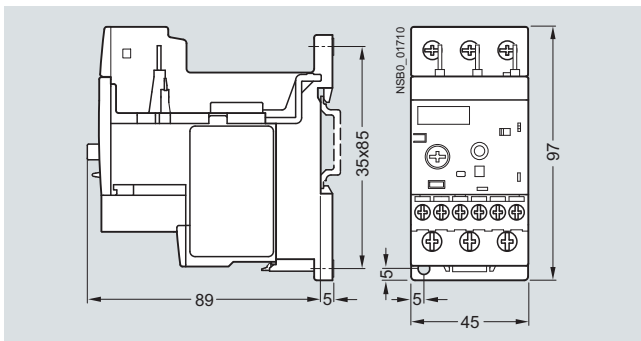

3RB20 66, 3RB21 63, size S10/S12

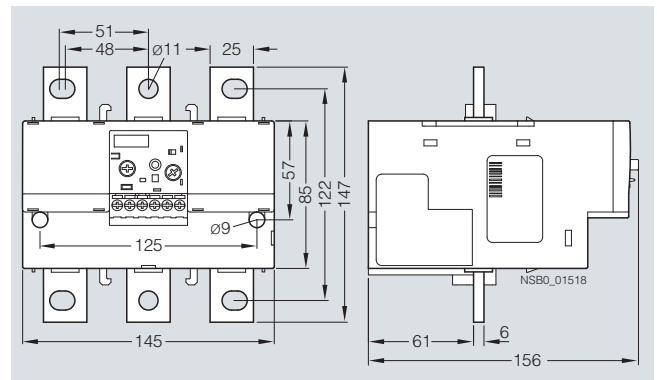

5

Overload Relays

3RB2 Solid-State Overload Relays

3RB20, 3RB21 for standard applications

3RB20 36, 3RB21 33, size S2 with straight-through transformer

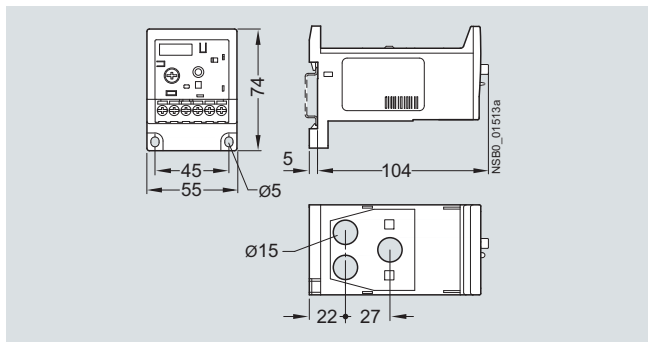

3RB20 56, 3RB21 53, size S6 with straight-through transformer

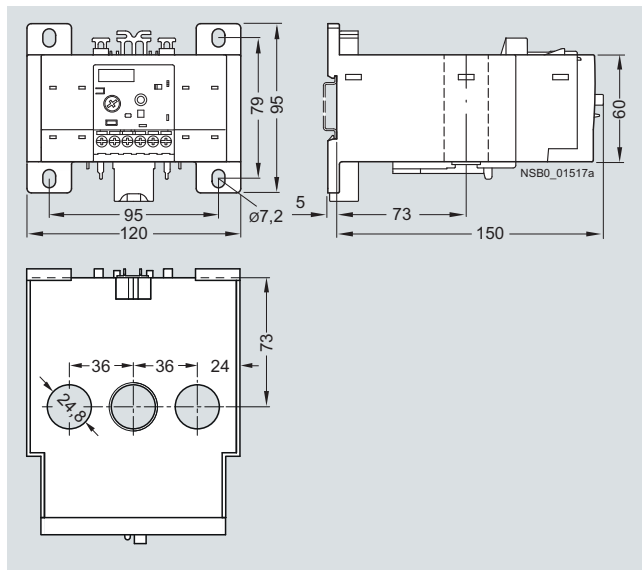

3RB20 46, 3RB21 43, size S3 with straight-through transformer

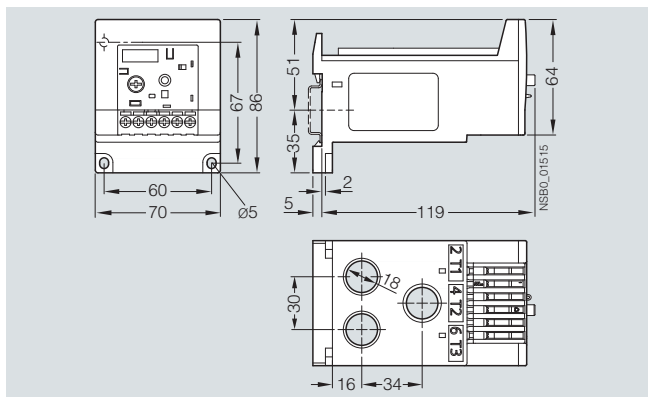

Schematics

3RB20 16

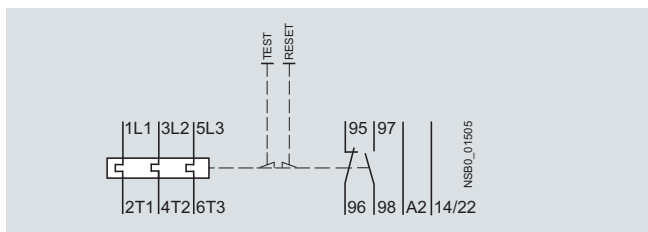

3RB21 13

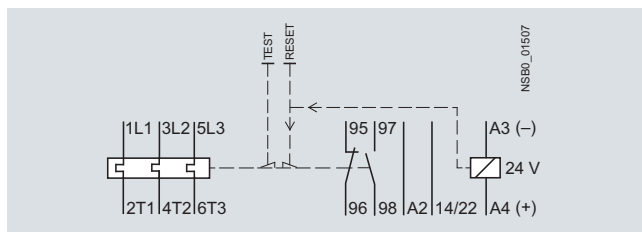

3RB20 26 to 3RB20 66

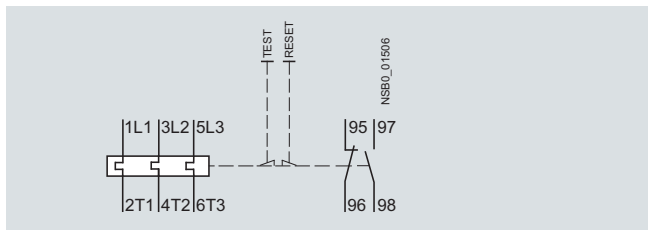

3RB21 23 to 3RB21 63

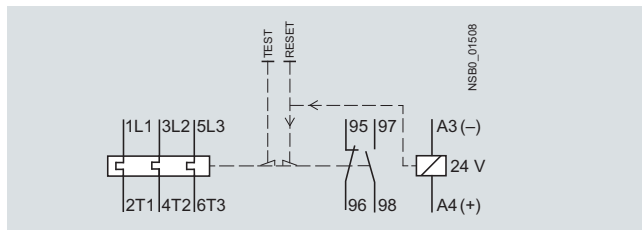

Overload Relays

3RB2 Solid-State Overload Relays

3RB22, 3RB23 for high-feature applications

Overview

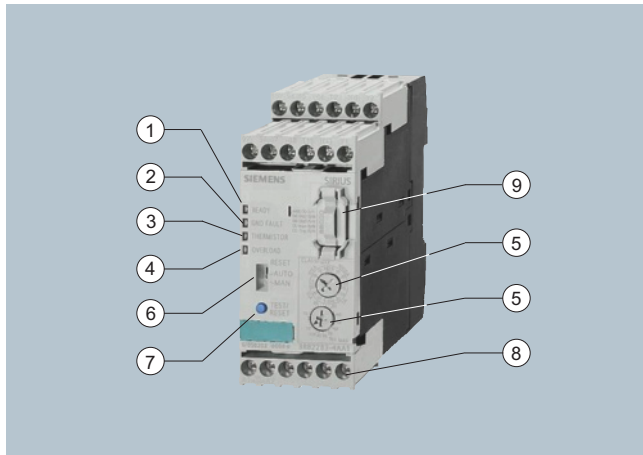

3RB22/3RB23 evaluation module

- (1) Green "READY" LED:
A continuous green light signals that the device is working correctly.
- (2) Red "GND FAULT" LED
A continuous red light signals a ground-fault tripping.
- (3) Red "THERMISTOR" LED:
A continuous red light signals an active thermistor trip.
- (4) Red "OVERLOAD" LED:
A continuous red light signals an active overload trip; a flickering red light signals an imminent trip (overload warning).
- (5) Motor current and trip class setting:
Setting the device to the motor current and to the required trip class dependent on the start-up conditions is easy with the two rotary switches.
- (6) Selector switch for manual/automatic RESET:
With this switch you can choose between manual and automatic RESET.
- (7) TEST/RESET button:
Enables testing of all important device components and functions, plus resetting of the device after a trip when manual RESET is selected.
- (8) Connecting terminals (removable joint block):
The generously sized terminals permit connection of two conductors with different cross-sections for the auxiliary, control and sensor circuits. Connection is possible with screw connection and alternatively with spring-type connection.
- (9) 3RB29 85 function expansion module:
Enables more functions to be added, e. g. internal ground-fault detection and/or an analog output with corresponding signals.

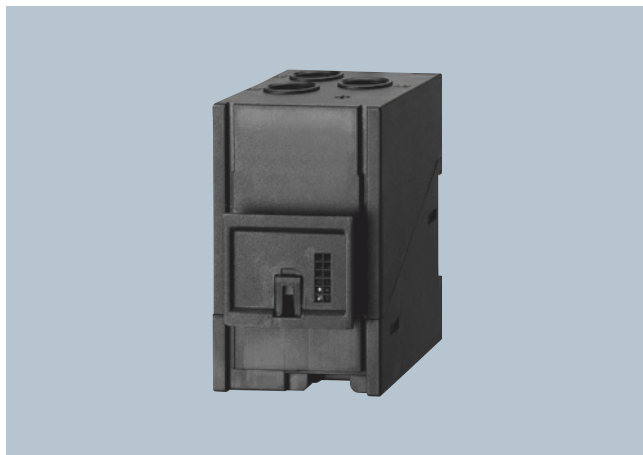

3RB29 06 current measuring module

The modular, solid-state overload relays with external power supply type 3RB22 (with monostable auxiliary contacts) and type 3RB23 (with bistable auxiliary contacts) up to 630 A (up to 820 A possible with a series transformer) have been designed for inverse-time delayed protection of loads with normal and heavy starting (see "Function") against excessive temperature rises due to overload, phase unbalance or phase failure. An overload, phase unbalance or phase failure result in an increase of the motor current beyond the set rated motor current. This current rise is detected by means of a current measuring module and electronically evaluated by a special evaluation module which is connected to it. The evaluation electronics sends a signal to the auxiliary contacts. The auxiliary contacts then switch off the load by means of a contactor. The break time depends on the ratio between the tripping current and current setting I_e and is stored in the form of a long-term stable tripping characteristic (see "Characteristic Curves"). The "tripped" status is signaled by means of a continuous red "OVERLOAD" LED.

The LED indicates imminent tripping of the relay due to overload, phase unbalance or phase failure by flickering when the limit current has been violated. This warning can also be issued as a signal through auxiliary contacts.

In addition to the described inverse-time delayed protection of loads against excessive temperature rises, the 3RB22/3RB23 solid-state overload relays also allow direct temperature monitoring of the motor windings (full motor protection) by connection with short-circuit and open-circuit detection of a PTC sensor circuit. With this temperature-dependent protection, the loads can be protected against overheating caused indirectly by reduced coolant flow, for example, which cannot be detected by means of the current alone. In the event of overheating, the devices switch off the contactor, and thus the load, by means of the auxiliary contacts. The "tripped" status is signaled by means of a continuously illuminated "THERMISTOR" LED.

To also protect the loads against high-resistance short-circuits due to damage to the insulation, humidity, condensed water, etc., the 3RB22/3RB23 solid-state overload relays offer the possibility of internal ground-fault detection in conjunction with a function expansion module (for details see Catalog LV 1, "Selection and ordering data"; not possible in conjunction with contactor assembly for wye-delta starting). In the event of a ground fault the 3RB22/3RB23 relays trip. The "tripped" status is signaled by means of a continuous red "GND FAULT" LED. Signaling through auxiliary contacts is also possible.

After tripping due to overload, phase unbalance, phase failure, thermistor or ground-fault tripping, the relay is reset manually or automatically after the recovery time has elapsed (see "Function").

In conjunction with a function expansion module the motor current measured by the microprocessor can be output in the form of an analog signal 4 ... 20 mA DC for operating rotary coil instruments or for feeding into analog inputs of programmable logic controllers. With an additional AS-Interface analog module the current values can also be transferred over the AS-i bus system.

The devices are manufactured in accordance with environmental guidelines and contain environmentally friendly and reusable materials.

They comply with all important worldwide standards and approvals.

Overload Relays

3RB2 Solid-State Overload Relays

3RB22, 3RB23 for high-feature applications

"Increased safety" type of protection EEx e acc. to ATEX directive 94/9/EC

The 3RB22 (monostable) solid-state overload relays are suitable for the overload protection of explosion-proof motors with "increased safety" type of protection EEx e; see Catalog LV 1, Chapter 20 "Appendix" --> "Standards and Approvals" --> "Type Overview of Approved Devices for Explosion-Protected Areas (ATEX Explosion Protection)".

Design

Device concept

The 3RB22/3RB23 solid-state overload relays are based on a modular device concept. Each device always comprises an evaluation module, which is independent of the motor current, and a current measuring module, which is dependent on the motor current. The two modules are electrically interconnected by a connection cable through the system interface.

The basic functionality of the evaluation module can be optionally expanded with corresponding function expansion modules. The function expansion modules are integrated in the evaluation module for this purpose through a simple plug-in connection.

Mounting options

Current measuring modules

The current measuring modules size S00/S0 and S2/S3 are designed for stand-alone installation. By contrast, the current measuring modules size S6 and S10/S12 are suitable for stand-alone installation and mounting onto contactors.

Evaluation modules

The evaluation modules can be mounted either on the current measuring module (only sizes S00/S0 and S2/S3) or separately.

For more information on the mounting options see "Technical specifications" and Catalog LV 1, "Selection and ordering data".

Connection methods

Main circuit (current measuring module)

For sizes S00/S0, S2/S3 and S6, the main circuit can also be connected by the straight-through transformer method. In this case, the cables of the main circuit are routed directly through the feed-through openings of the relay to the contactor terminals.

For sizes S6 and S10/S12, the main circuit can be connected with the help of rails. In conjunction with the corresponding box terminals, screw connection is also possible.

Auxiliary circuit (evaluation module)

Connection of the auxiliary circuit (removable joint block) is possible with either screw or spring-type terminal connection system (special versions).

For more information on the connection options see "Technical specifications" and Catalog LV 1, "Selection and ordering data".

Overload relays in contactor assemblies for wye-delta starting

When overload relays are used in combination with contactor assemblies for wye-delta starting it must be noted that only 0.58 times the motor current flows through the line contactor. An overload relay mounted onto the line contactor must be set to 0.58 times the motor current.

When 3RB22/3RB23 solid-state overload relays are used in combination with contactor assemblies for wye-delta starting, the function expansion modules for internal ground-fault detection must not be used.

Operation with frequency converter

The 3RB22/3RB23 solid-state overload relays are suitable for frequencies of 50/60 Hz and the associated harmonics. This permits the 3RB22/3RB23 overload relays to be used on the input side of the frequency converter.

If motor protection is required on the outgoing side of the frequency converter, Siemens recommends the 3RN thermistor motor protection devices or the 3RU11 thermal overload relays for this purpose.

Overload Relays

3RB2 Solid-State Overload Relays

3RB22, 3RB23 for high-feature applications

Function

Basic functions

The 3RB22/3RB23 solid-state overload relays are designed for:

- Inverse-time delayed protection of loads from overloading
- Inverse-time delayed protection of loads from phase unbalance
- Inverse-time delayed protection of loads from phase failure
- Temperature-dependent protection of loads by connecting a PTC sensor circuit
- Protection of loads from high-resistance short-circuits (internal ground-fault detection; detection of fault currents > 30 % of the current setting I_e)
- Output of an overload warning
- Output of an analog signal 4 to 20 mA DC as image of the flowing motor current

The basic functions of the evaluation modules in conjunction with function expansion modules are listed in the following table:

Evaluation modules	Function expansion modules	Basic functions
3RB22 83-4AA1 3RB22 83-4AC1 3RB23 83-4AA1 3RB23 83-4AC1	None	Inverse-time delayed protection, temperature-dependent protection, electrical remote RESET, overload warning
	3RB29 85-2CA1	Inverse-time delayed protection, temperature-dependent protection, internal ground-fault detection, electrical remote RESET, overload warning
	3RB29 85-2CB1	Inverse-time delayed protection, temperature-dependent protection, internal ground-fault detection, electrical remote RESET, ground-fault signal
	3RB29 85-2AA0	Inverse-time delayed protection, temperature-dependent protection, electrical remote RESET, overload warning, analog output
	3RB29 85-2AA1	Inverse-time delayed protection, temperature-dependent protection, internal ground-fault detection, electrical remote RESET, overload warning, analog output
	3RB29 85-2AB1	Inverse-time delayed protection, temperature-dependent protection, internal ground-fault detection, electrical remote RESET, ground-fault signal, analog output

Control circuit

The 3RB22/3RB23 solid-state overload relays require an external power supply, i. e. an additional supply voltage is necessary. Power is supplied through a wide-range power supply unit for 24 to 240 V AC/DC.

Short-circuit protection

Fuses or motor starter protectors must be used for short-circuit protection.

For assignments of the corresponding short-circuit protection devices to the 3RB22/3RB23 solid-state overload relays with/without contactor see "Technical specifications" and Catalog LV 1, "Selection and ordering data".

Trip classes

The 3RB22/3RB23 solid-state overload relays are suitable for normal and heavy starting conditions. The required trip class (CLASS 5, 10, 20 or 30) can be adjusted by means of a rotary switch depending on the current start-up condition.

For details of the trip classes see "Characteristic Curves".

Phase failure protection

The 3RB22/3RB23 solid-state overload relays are fitted with phase failure protection (see "Characteristic Curves") in order to minimize temperature rises of the load during single-phase operation.

Setting

The 3RB22/3RB23 solid-state overload relays are set to the rated motor current by means of two rotary knobs.

- The upper rotary knob (CLASS/ I_{emax}) is divided into 4 ranges: 1 A, 10 A, 100 A and 1000 A. The zone must be selected which corresponds to the rated motor current and the current measuring module to be used with it. With the range selected the required trip class (CLASS 5, 10, 20 or 30) can be determined.
- The lower rotary knob with percent scale (10 ... 100 %) is then used to set the rated motor current in percent of the range selected with the upper rotary knob.

Example

- Rating of induction motor = 45 kW (AC 50 Hz, 400 V)
- Rated motor current = 80 A
- Required trip class = CLASS 20
- Selected transformer: 10 ... 100 A

Solution

- Step 1: Use the upper rotary knob (CLASS) to select the 100 A range
- Step 2: Within the 100 A range set the trip class CLASS 20
- Step 3: Set the lower rotary knob to 80 % (= 0.8) corresponding to 100 A × 0.8 = 80 A.

If the current which is set on the evaluation module does not correspond to the current range of the connected current transformer, an error will result.

Manual and automatic reset

In the case of the 3RB22/3RB23 solid-state overload relays, a slide switch can be used to choose between automatic and manual resetting.

If manual reset is set, a reset can be carried out directly on the device after a trip by pressing the blue TEST/RESET button. A remote RESET can be carried out electrically by jumpering the terminals Y1 and Y2.

If the slide switch is set to automatic RESET, the relay is reset automatically.

The time between tripping and resetting is determined by the recovery time.

Overload Relays

3RB2 Solid-State Overload Relays

3RB22, 3RB23 for high-feature applications

Recovery time

With the 3RB22/3RB23 solid-state overload relays the recovery time after inverse-time delayed tripping is approx. 3 minutes regardless of the selected reset mode. The recovery time allows the load to cool down.

However, in the event of temperature-dependent tripping by means of a connected PTC sensor circuit, the device can only be manually or automatically reset once the winding temperature at the installation location of the PTC thermistor has fallen 5 Kelvin below its response temperature.

After a ground-fault tripping the 3RB22/3RB23 solid-state overload relay trips can be reset immediately without a recovery time.

TEST function

The combined TEST/RESET button can be used to check whether the relay is working correctly. The test can be aborted at any time by letting go of the TEST/RESET button.

LEDs, the device configuration (this depends on which expansion module is plugged in) and the device hardware are tested while the button is kept pressed for 6 seconds. Simultaneously and for another 18 seconds a direct current proportional in size to the maximum phase of the main current is fed in at the terminals I(+) and I(-). By comparing the analog signal, which is to be measured, with the main current, the accuracy of the current measurement can be determined. In this case 4 mA corresponds to 0 % and 20 mA to 125 % of the current setting. After 24 seconds the auxiliary contacts are switched and the feeder switch off as the result, bringing the test to an end.

After a test trip a faultless relay is reset by pressing the TEST/RESET button. If a hardware fault is detected, the device trips and cannot be reset.

Self-monitoring

The 3RB22/3RB23 solid-state overload relays have a self-monitoring feature, i. e. the devices constantly monitor their own basic functions and trip if an internal fault is detected.

Display of the operating state

The particular operating state of the 3RB22/3RB23 solid-state overload relays is displayed by means of four LEDs:

- Green "READY" LED: A continuous green light signals that the overload relay is ready for operation. The 3RB22/3RB23 overload relays are not ready (LED "OFF") if there is no control supply voltage or if the function test was negative.
- Red "GND FAULT" LED: A continuous red light signals a ground fault.
- Red "THERMISTOR" LED: A continuous red light signals a temperature-dependent trip.
- Red "OVERLOAD" LED: A continuous red light signals an inverse-time delayed trip; a flickering red light signals an imminent inverse-time delayed trip (overload warning).

Auxiliary contacts

The 3RB22/3RB23 solid-state overload relays have two outputs, each with one NO contact and one NC contact. Their basic assignment/function may be influenced by function expansion modules.

The 3RB22 and 3RB23 differ with respect to the tripping characteristics of their auxiliary contacts – monostable or bistable:

The monostable 3RB22 solid-state overload relays will enter the "tripped" state if the control voltage fails (> 200 ms), and return to the original state they were in before the control supply voltage failed when the voltage returns. These devices are therefore especially suited for plants in which the control voltage is not strictly monitored.

The bistable 3RB23 overload relays do not change their "tripped" or "not tripped" status if the control voltage fails. The auxiliary contacts only switch over in the event of an overload and if the supply voltage is present. These devices are therefore especially suited for plants in which the control voltage is monitored separately.

Response if the control supply voltage fails

If the control supply voltage fails for more than 0.2 s, the output relays respond differently depending on the version: monostable or bistable.

Response of the output relays in the event of	Monostable 3RB22	Bistable 3RB23
Failure of the control supply voltage	The device trips	No change of the switching state of the auxiliary contacts
Return of the control supply voltage without previous tripping	The device resets	No change of the switching state of the auxiliary contacts
Return of the control supply voltage after previous tripping	The device remains tripped Reset: • For overload tripping, after 3 minutes • For thermistor tripping, after the temperature has fallen 5 K below the response temperature • For ground-fault tripping, immediately	The device remains tripped Reset: • For overload tripping, after 3 minutes • For thermistor tripping, after the temperature has fallen 5 K below the response temperature • For ground-fault tripping, immediately

Monostable and bistable responses of the output relays

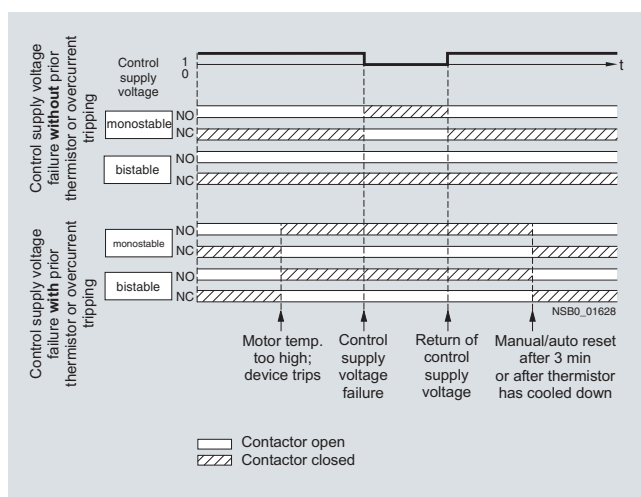

Overload Relays

3RB2 Solid-State Overload Relays

3RB22, 3RB23 for high-feature applications

Technical specifications

Type – Overload relay of complete system	3RB22, 3RB23	
Size	S00 ... S10/S12	
General data		
Trips in the event of	Overload, phase failure and phase unbalance (> 40 % acc. to NEMA), + ground fault (with corresponding function expansion module) and activation of the thermistor motor protection (with closed PTC sensor circuit)	
Trip class acc. to IEC 60947-4-1	CLASS	5, 10, 20 and 30 adjustable
Phase failure sensitivity	Yes	
Overload warning	Yes, from $1.125 \times I_{\theta}$ for symmetrical loads and from $0.85 \times I_{\theta}$ for unsymmetrical loads	
Reset and recovery	Manual, automatic and remote RESET	
<ul style="list-style-type: none"> Reset options after tripping Recovery time <ul style="list-style-type: none"> - For automatic RESET 	min	<ul style="list-style-type: none"> - For tripping due to overcurrent: 3 (stored permanently) - For tripping by thermistor: time until the motor temperature has fallen 5 K below the response temperature
<ul style="list-style-type: none"> - For manual RESET 	min	<ul style="list-style-type: none"> - For tripping due to a ground fault: no automatic RESET - For tripping due to overcurrent: 3 (stored permanently) - For tripping by thermistor: time until the motor temperature has fallen 5 K below the response temperature
<ul style="list-style-type: none"> - For remote RESET 	min	<ul style="list-style-type: none"> - For tripping due to a ground fault: immediately - For tripping due to overcurrent: 3 (stored permanently) - For tripping by thermistor: time until the motor temperature has fallen 5 K below the response temperature - For tripping due to a ground fault: immediately
Features		
<ul style="list-style-type: none"> Display of operating state on device 	Yes, with 4 LEDs: Green "Ready" LED, red "Ground Fault" LED, red "Thermistor" LED and red "Overload" LED	
<ul style="list-style-type: none"> TEST function 	Yes, test of LEDs, electronics, auxiliary contacts and wiring of control circuit by pressing the button TEST/RESET / self-monitoring	
<ul style="list-style-type: none"> RESET button STOP button 	Yes, with the TEST/RESET button No	
Explosion protection – safe operation of motors with "increased safety" type of protection		
EC type test certificate number acc. to directive 94/9/EC (ATEX)	PTB 05 ATEX 3022 🇪🇺 II (2) GD	
Ambient temperatures		
<ul style="list-style-type: none"> Storage/transport 	°C	-40 ... +80
<ul style="list-style-type: none"> Operation 	°C	-25 ... +60
<ul style="list-style-type: none"> Temperature compensation 	°C	+60
<ul style="list-style-type: none"> Permissible rated current <ul style="list-style-type: none"> - Temperature inside control cabinet 60 °C - Temperature inside control cabinet 70 °C 	%	100 1)
Repeat terminals		
<ul style="list-style-type: none"> Coil repeat terminal 	Not required	
<ul style="list-style-type: none"> Auxiliary contact repeat terminal 	Not required	
Degree of protection acc. to IEC 60529	IP20 ²⁾	
Touch protection acc. to IEC 61140	Finger-safe ²⁾	
Shock resistance with sine acc. to IEC 60068-2-27	g/ms	15/11
Electromagnetic compatibility (EMC)		
– Interference immunity		
<ul style="list-style-type: none"> Conductor-related interference <ul style="list-style-type: none"> - Burst acc. to IEC 61000-4-4 (corresponds to degree of severity 3) - Surge acc. to IEC 61000-4-5 (corresponds to degree of severity 3) 	kV	2 (power ports), 1 (signal ports)
<ul style="list-style-type: none"> Electrostatic discharge acc. to IEC 61000-4-2 (corresponds to degree of severity 3) 	kV	8 (air discharge), 6 (contact discharge)
<ul style="list-style-type: none"> Field-related interference acc. to IEC 61000-4-3 (corresponds to degree of severity 3) 	V/m	10
Electromagnetic compatibility (EMC) – emitted interference		
Degree of severity A acc. to EN 55011 (CISPR 11) and EN 55022 (CISPR 22)		
Resistance to extreme climates – air humidity	%	100
Dimensions		
See dimensional drawings		
Installation altitude above sea level	m	Up to 2000
Mounting position	Any	
Type of mounting	Evaluation module: stand-alone installation, current measuring module size S00 to S3: stand-alone installation, current measuring module size S6 and S10/S12: stand-alone installation and mounting onto contactors	

1) On request.

2) Current measuring modules size S6 and S10/S12 with busbar connection in conjunction with cover.

Overload Relays

3RB2 Solid-State Overload Relays

3RB22, 3RB23 for high-feature applications

Type – Overload relay of current measuring module		3RB29 06	3RB29 06	3RB29 56	3RB29 66
Size		S00/S0	S2/S3	S6	S10/S12
Width		45 mm	55 mm	120 mm	145 mm
Main circuit					
Rated insulation voltage U_i (degree of pollution 3)	V	1000			
Rated impulse withstand voltage U_{imp}	kV	6		8	
Rated operational voltage U_e	V	1000			
Type of current		No			
• Direct current		Yes, 50/60 Hz $\pm 5\%$			
• Alternating current					
Current setting	A	0.3 ... 3; 2.4 ... 25	10 ... 100	20 ... 200	63 ... 630
Power loss per unit (max.)	W	0.5			
Short-circuit protection		See Catalog LV 1, "Selection and ordering data". See "Technical specifications" (short-circuit protection with fuses for motor feeders)			
• With fuse without contactor					
• With fuse and contactor					
Protective separation between main and auxiliary conducting path acc. to IEC 60947-1 (degree of pollution 2)	V	690 ¹⁾			
Connection for main circuit					
Connection type		 Screw terminals with box terminal			
• Terminal screw		--		4 mm Allen screw	5 mm Allen screw
• Tightening torque	Nm	--		10 ... 12	20 ... 22
• Conductor cross-sections (min./max.), 1 or 2 conductors					
- Solid	mm ²	--		--	--
- Finely stranded without end sleeve	mm ²	--		With 3RT19 55-4G box terminal: 2 × (1 × max. 50, 1 × max. 70), 1 × (10 ... 70)	2 × (50 ... 185), Front clamping point only: 1 × (70 ... 240)
				With 3RT19 56-4G box terminal: 2 × (1 × max. 95, 1 × max. 120), 1 × (10 ... 120)	Rear clamping point only: 1 × (120 ... 185)
- Finely stranded with end sleeve	mm ²	--		With 3RT19 55-4G box terminal: 2 × (1 × max. 50, 1 × max. 70), 1 × (10 ... 70)	2 × (50 ... 185), Front clamping point only: 1 × (70 ... 240)
				With 3RT19 56-4G box terminal: 2 × (1 × max. 95, 1 × max. 120), 1 × (10 ... 120)	Rear clamping point only: 1 × (120 ... 185)
- Stranded	mm ²	--		With 3RT19 55-4G box terminal: 2 × (max. 70), 1 × (16 ... 70)	2 × (70 ... 240), Front clamping point only: 1 × (95 ... 300)
				With 3RT19 56-4G box terminal: 2 × (max. 120), 1 × (16 ... 120)	Rear clamping point only: 1 × (120 ... 240)
- AWG cables, solid or stranded	AWG	--		With 3RT19 55-4G box terminal: 2 × (max. 1/0), 1 × (6 ... 2/0)	2 × (2/0 ... 500 kcmil), Front clamping point only: 1 × (3/0 ... 600 kcmil)
				With 3RT19 56-4G box terminal: 2 × (max. 3/0), 1 × (6 ... 250 kcmil)	Rear clamping point only: 1 × (250 kcmil ... 500 kcmil)
- Ribbon cable conductors (number x width x thickness)	mm	--		With 3RT19 55-4G box terminal: 2 × (6 × 15.5 × 0.8), 1 × (3 × 9 × 0.8 ... 6 × 15.5 × 0.8)	2 × (20 × 24 × 0.5), 1 × (6 × 9 × 0.8 ... 20 × 24 × 0.5)
				With 3RT19 56-4G box terminal: 2 × (10 × 15.5 × 0.8), 1 × (3 × 9 × 0.8 ... 10 × 15.5 × 0.8)	
Connection type		Busbar connections			
• Terminal screw		--		M8 × 25	M10 × 30
• Tightening torque	Nm	--		10 ... 14	14 ... 24
• Conductor cross-section (min./max.)					
- Solid with cable lug	mm ²	--		16 ... 95 ²⁾	50 ... 240 ³⁾
- Stranded with cable lug	mm ²	--		25 ... 120 ²⁾	70 ... 240 ³⁾
- AWG cables, solid or stranded, with cable lug	AWG	--		4 ... 250 kcmil	2/0 ... 500 kcmil
- With connecting bar (max. width)	mm	--		15	25
Connection type		Straight-through transformers			
Diameter of opening	mm	7.5	14	25	--

¹⁾ For grounded networks, otherwise 600 V.



²⁾ When connecting cable lugs according to DIN 46235, use the 3RT19 56-4EA1 terminal cover for conductor cross-sections from 95 mm² to ensure phase spacing.

³⁾ When connecting cable lugs according to DIN 46234 for conductor cross-sections from 240 mm² as well as DIN 46235 for conductor cross-sections from 185 mm², use the 3RT19 56-4EA1 terminal cover to ensure phase spacing.

Overload Relays

3RB2 Solid-State Overload Relays

3RB22, 3RB23 for high-feature applications

Type – Overload relay of evaluation module		3RB22 83, 3RB23 83	
Size		S00 ... S10/S12	
Width		45 mm	
Auxiliary circuit			
Number of NO contacts		2	
Number of NC contacts		2	
Auxiliary contacts – assignment		1 NO for the signal "tripped due to overload and/or thermistor", 1 NC for switching off the contactor 1 NO for the signal "tripped due to ground fault", 1 NC for switching off the contactor or ¹⁾ 1 NO for the signal "tripped due to overload and/or thermistor and/or ground fault", 1 NC for switching off the contactor 1 NO for overload warning, 1 NC for switching off the contactor	
Rated insulation voltage U_i (degree of pollution 3)		V	300
Rated impulse withstand voltage U_{imp}		kV	4
Auxiliary contacts – contact rating			
• NC contact with alternating current AC-14/AC-15 Rated operational current I_o at U_o :			
- 24 V	A	6	
- 120 V	A	6	
- 125 V	A	6	
- 250 V	A	3	
• NO contact with alternating current AC-14/AC-15: Rated operational current I_o at U_o :			
- 24 V	A	6	
- 120 V	A	6	
- 125 V	A	6	
- 250 V	A	3	
• NC, NO contact with direct current DC-13: Rated operational current I_o at U_o :			
- 24 V	A	2	
- 60 V	A	0.55	
- 110 V	A	0.3	
- 125 V	A	0.3	
- 250 V	A	0.2	
• Conventional thermal current I_{th}		A	5
• Contact reliability (suitability for PLC control; 17 V, 5 mA)		Yes	
Short-circuit protection			
• With fuse, gL/gG operational class		A	6
• With miniature circuit breaker (C characteristic)		A	1.6
Protective separation between main and auxiliary conducting path Acc. to IEC 60947-1		V	300
CSA, UL, UR rated data			
Auxiliary circuit – switching capacity		B300, R300	
Connection of the auxiliary circuit			
Connection type		 Screw terminals	
• Terminal screw		Pozi driv size 2	
• Tightening torque		Nm	0.8 ... 1.2
• Conductor cross-section (min./max.), 1 or 2 conductors			
- Solid	mm ²	1 × (0.5 ... 4), 2 × (0.5 ... 2.5)	
- Finely stranded without end sleeve	mm ²	--	
- Finely stranded with end sleeve	mm ²	1 × (0.5 ... 2.5), 2 × (0.5 ... 1.5)	
- Stranded	mm ²	--	
- AWG cables, solid or stranded	AWG	2 × (20 ... 14)	
Connection type		 Spring-type terminals	
• Conductor cross-section (min./max.), 1 or 2 conductors			
- Solid	mm ²	2 × (0.25 ... 1.5)	
- Finely stranded without end sleeve	mm ²	--	
- Finely stranded with end sleeve	mm ²	2 × (0.25 ... 1.5)	
- Stranded	mm ²	2 × (0.25 ... 1.5)	
- AWG cables, solid or stranded	AWG	2 × (24 ... 16)	

¹⁾ The assignment of auxiliary contacts may be influenced by function expansion modules.



Overload Relays

3RB2 Solid-State Overload Relays

3RB22, 3RB23 for high-feature applications

Type – Overload relay of evaluation module	3RB22 83, 3RB23 83	
Size	S00 ... S10/S12	
Width	45 mm	
Control and sensor circuit as well as the analog output		
Rated insulation voltage U_i (degree of pollution 3) ¹⁾	V	300
Rated impulse withstand voltage U_{imp} ¹⁾	kV	4
Rated control supply voltage U_s ¹⁾		
• AC 50/60 Hz	V	24 ... 240
• DC	V	24 ... 240
Operating range ¹⁾		
• AC 50/60 Hz		$0.85 \times U_{s \min} \leq U_s \leq 1.1 \times U_{s \max}$
• DC		$0.85 \times U_{s \min} \leq U_s \leq 1.1 \times U_{s \max}$
Rated power ¹⁾		
• AC 50/60 Hz	W	0.5
• DC	W	0.5
Mains buffering time ¹⁾	ms	200
Thermistor motor protection (PTC thermistor detector) ²⁾		
• Summation cold resistance	k Ω	≤ 1.5
• Response value	k Ω	3.4 ... 3.8
• Return value	k Ω	1.5 ... 1.65
Ground-fault detection		The information refers to sinusoidal residual currents at 50/60 Hz
• Tripping value I_{Δ} ³⁾		
- For $0.3 \times I_e < I_{motor} < 2.0 \times I_e$		$> 0.3 \times I_e$
- For $2.0 \times I_e < I_{motor} < 8.0 \times I_e$		$> 0.15 \times I_{motor}$
• Response time t_{trip}	ms	500 ... 1000
Analog output ³⁾⁴⁾		
• Output signal	mA	4 ... 20
• Measuring range		0 to $1.25 \times I_e$ 4 mA corresponds to $0 \times I_e$ 16.8 mA corresponds to $1.0 \times I_e$ 20 mA corresponds to $1.25 \times I_e$
• Load, max.	Ω	100

Connection for the control and sensor circuit as well as the analog output

Connection type	 Screw terminals	
• Terminal screw		Pozidriv size 2
• Tightening torque	Nm	0.8 ... 1.2
• Conductor cross-section (min./max.), 1 or 2 conductors		
- Solid	mm ²	1 × (0.5 ... 4), 2 × (0.5 ... 2.5)
- Finely stranded without end sleeve	mm ²	--
- Finely stranded with end sleeve	mm ²	1 × (0.5 ... 2.5), 2 × (0.5 ... 1.5)
- Stranded	mm ²	--
- AWG cables, solid or stranded	AWG	2 × (20 ... 14)
Connection type	 Spring-type terminals	
• Conductor cross-section (min./max.), 1 or 2 conductors		
- Solid	mm ²	2 × (0.25 ... 1.5)
- Finely stranded without end sleeve	mm ²	--
- Finely stranded with end sleeve	mm ²	2 × (0.25 ... 1.5)
- Stranded	mm ²	2 × (0.25 ... 1.5)
- AWG cables, solid or stranded	AWG	2 × (24 ... 16)

¹⁾ Control circuit.

²⁾ Sensor circuit.

³⁾ In conjunction with corresponding function expansion module.

⁴⁾ Analog input modules, e. g. SM 331, must be configured for 4-wire measuring transducers. In this case the analog input module must not supply current to the analog output of the 3RB22/3RB23 relay.

Overload Relays

3RB2 Solid-State Overload Relays

3RB22, 3RB23 for high-feature applications

Short-circuit protection with fuses for motor feeders

For short-circuit currents up to 50 kA or 100 kA
at rated operational voltages up to 690 V

Overload relays	Contactors	CLASS 5 and 10			CLASS 20			CLASS 30			690 V/ 50 kA		690 V/ 100 kA		690 V/ 50 kA	415 V/ 50 kA	600 V/ SSCR	
		Rated operational current I_e AC-3 in A at ... V									Rated operational current I_e AC-3 in A for type of coordination ²⁾							
Setting range	Type	400	500	690	400	500	690	400	500	690	1	2	1	2	2	2	--	
Size S00/S0³⁾																		
0.3 ... 3	3RT10 15	3	3	3	3	3	3	3	3	3	35	20	20	20	--	20	10	
	3RT10 16	3	3	3	3	3	3	3	3	3	35	20	20	20	--	20	10	
2.4 ... 25	3RT10 15	7	5	4	7	5	4	7	5	4	35	20	20	20	--	20	60	
	3RT10 16	9	6.5	5.2	9	6.5	5.2	9	6.5	5.2	35	20	20	20	--	20	60	
	3RT10 17	12	9	6.3	10	9	6.3	9	9	6.3	35	20	20	20	--	20	60	
	3RT10 23	9	6.5	5.2	9	6.5	5.2	--	--	--	63	25	25	25	--	25	70	
	3RT10 24	12	12	9	12	12	9	12	12	9	63	25	25	25	20	25	70	
	3RT10 25	17	17	13	16	16	13	14	14	13	63	25	25	25	20	25	70	
	3RT10 26	25	18	13	16	16	13	14	14	13	100	35	35	35	20	25	100	
	3RT10 34	25	25	20	22.3	22.3	20	19.1	19.1	19.1	125	63	63	63	50	63	100	
	3RT10 35	25	25	24	25	25	24	25	25	24	125	63	63	63	50	63	100	
Size S2/S3³⁾																		
10 ... 100	3RT10 34	32	32	20	22.3	22.3	20	19.1	19.1	19.1	125	63	63	63	50	63	125	
	3RT10 35	40	40	24	29.4	29.4	24	26.5	26.5	24	125	63	63	63	50	80	150	
	3RT10 36	50	50	24	32.7	32.7	24	26.5	26.5	24	160	80	80	80	50	80	200	
	3RT10 44	65	65	47	49	49	47	41.7	41.7	41.7	200	125	125	125	63	125	250	
	3RT10 45	80	80	58	53	53	53	45	45	45	200	160	160	160	80	160	300	
	3RT10 46	95	95	58	59	59	58	50	50	50	200	160	160	160	100	160	350	
	3RT10 54	100	100	100	81.7	81.7	81.7	69	69	69	355	315	315	315	160	250	400	
	3RT10 55	--	--	--	100	100	100	90	90	90	355	315	315	315	200	315	400	
	Size S6																	
20 ... 200	3RT10 54	115	115	115	81.7	81.7	81.7	69	69	69	355	315	315	315	160	250	450	
	3RT10 55	150	150	150	107	107	107	90	90	90	355	315	315	315	200	315	500	
	3RT10 56	185	185	170	131	131	131	111	111	111	355	315	315	315	200	315	500	
Size S10/S12																		
63 ... 630	3RT10 64	225	225	225	160	160	160	135	135	135	500	400	400	400	250	400	600	
	3RT10 65	265	265	265	188	188	188	159	159	159	500	400	400	400	315	400	700	
	3RT10 66	300	300	280	213	213	213	180	180	180	500	400	400	400	315	400	800	
	3RT10 75	400	400	400	284	284	284	240	240	240	630	500	500	500	400	450	1000	
	3RT10 76	500	500	450	355	355	355	300	300	300	630	500	500	500	500	500	1200	
	3RT12 64	225	225	225	225	225	225	173	173	173	500	500	500	500	400	450	600	
	3RT12 65	265	265	265	265	265	265	204	204	204	500	500	500	500	400	450	700	
	3RT12 66	300	300	300	300	300	300	231	231	231	500	500	500	500	400	450	800	
	3RT12 75	400	400	400	400	400	400	316	316	316	800	800	800	--	630	800	1000	
	3RT12 76	500	500	500	500	500	500	385	385	385	800	800	800	--	630	800	1200	
	3TF68 ³⁾	630	630	630	440	440	440	376	376	376	800	500 ⁴⁾	500 ⁴⁾	500 ⁴⁾	630	500	1600	
	3TF69 ³⁾	630	630	630	572	572	572	500	500	500	800	630 ⁴⁾	630 ⁴⁾	--	630	630	1600	
	Size 14																	
	0.3 ... 3 ⁵⁾	3TF69 ³⁾	820	820	820	572	572	572	500	500	500	800	630 ⁴⁾	630 ⁴⁾	--	630	630	1600

1) Please observe operational voltage.

SSCR = Standard Short-Circuit Rating

2) Assignment and short-circuit protective devices according to IEC 60947-4-1:

The contactor or starter must not endanger persons or the installation in the event of a short-circuit.

Type of coordination "1": The contactor or the starter may be non-operational after every short-circuit release.

Type of coordination "2": The contactor or the starter must be operational after a short-circuit release (without replacement of parts). There is a risk of contact welding.

3) Contactors not mountable.

4) Please ensure that the maximum AC-3 operational current has sufficient safety clearance from the rated current of the fuses.

5) With 3UF18 68-3GA00 current transformer.

Overload Relays

3RB2 Solid-State Overload Relays

3RB22, 3RB23 for high-feature applications

Characteristic curves

The tripping characteristics show the relationship between the tripping time and tripping current as multiples of the current setting I_e and are given for symmetrical three-pole and two-pole loads from the cold state.

The smallest current used for tripping is called the minimum tripping current. According to IEC 60947-4-1, this current must be within specified limits. The limits of the minimum tripping current for the 3RB22/3RB23 solid-state overload relays for symmetrical three-pole loads lie between 105 and 120 % of the current setting.

The tripping characteristic starts with the minimum tripping current and continues with higher tripping currents based on the characteristics of the so-called trip classes (CLASS 10, CLASS 20 etc.). The trip classes describe time intervals within which the overload relays have to trip with 7.2 times the current setting I_e from the cold state for symmetrical three-pole loads.

The tripping times according to IEC 60947-4-1, tolerance band E, are as follows for:

Trip class	Tripping time
CLASS 5	3 ... 5 s
CLASS 10	5 ... 10 s
CLASS 20	10 ... 20 s
CLASS 30	20 ... 30 s

The tripping characteristic for a three-pole overload relay from the cold state (see illustration 1) only apply if all three phases are simultaneously loaded with the same current. In the event of a phase failure or a current unbalance of more than 40 %, the 3RB22/3RB23 solid-state overload relays switch off the contactor more quickly in order to minimize heating of the load in accordance with the tripping characteristic for two-pole loads from the cold state (see illustration 2).

Compared with a cold load, a load at operating temperature obviously has a lower temperature reserve. The tripping time of the 3RB22/3RB23 solid-state overload relays is reduced therefore to about 20 % when loaded with the current setting I_e for an extended period.

Tripping characteristics for 3-pole loads

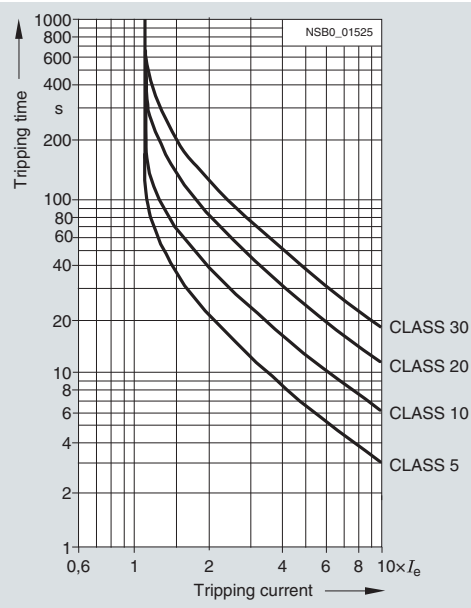

Illustration 1

Tripping characteristics for 2-pole loads

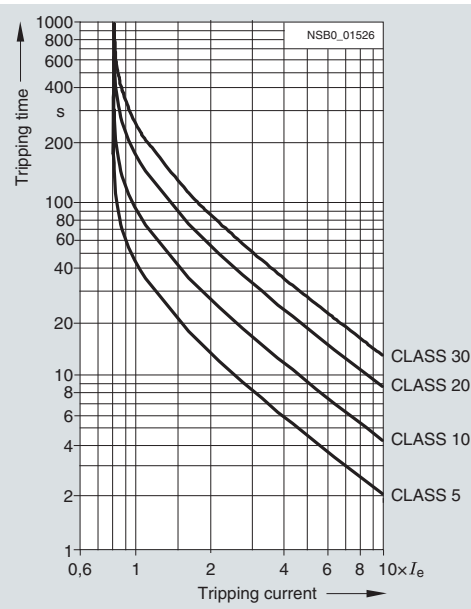

Illustration 2

The above illustrations are schematic representations of characteristic curves. The characteristic curves of the individual 3RB22/3RB23 electronic overload relays can be ordered from "Technical Assistance":

- Either by e-mail to: technical-assistance@siemens.com
- Or on the Internet at: <http://www.siemens.com/automation/service&support>

Overload Relays

3RB2 Solid-State Overload Relays

3RB22, 3RB23 for high-feature applications

Dimensional drawings

3RB22 83-4, 3RB23 83-4 evaluation module

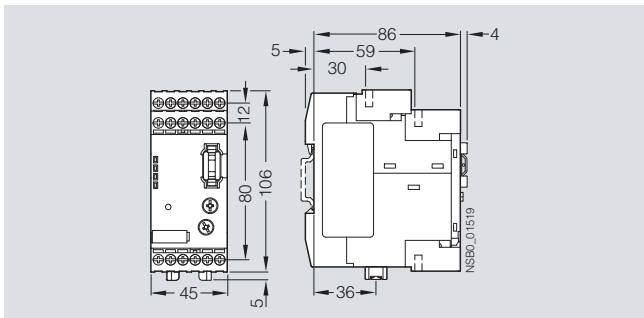

3RB29 06-2BG1, 3RB29 06-2DG1 current measuring module

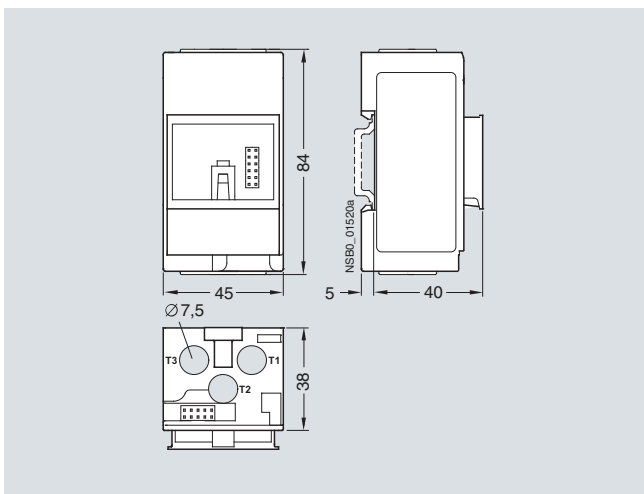

3RB29 06-2JG1 current measuring module

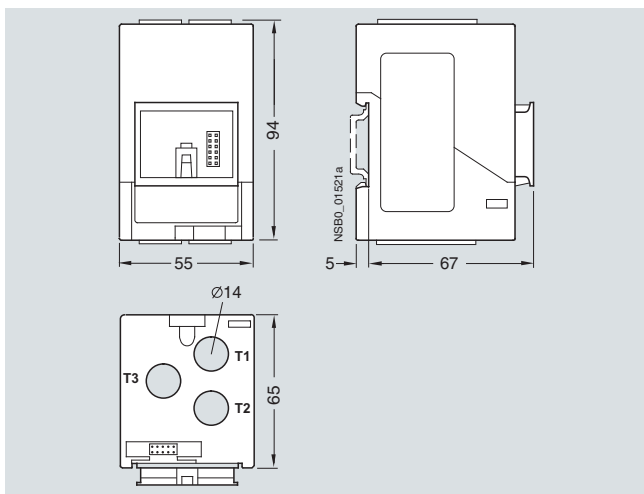

3RB29 56-2TG2 current measuring module

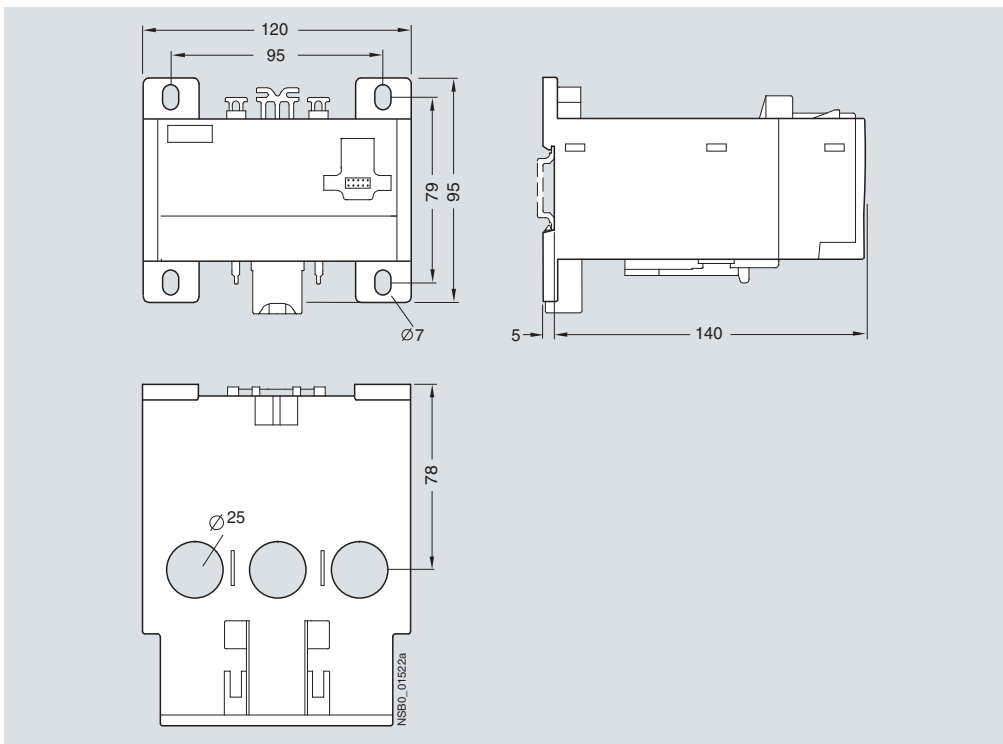

5

Overload Relays

3RB2 Solid-State Overload Relays

3RB22, 3RB23 for high-feature applications

3RB29 56-2TH2 current measuring module

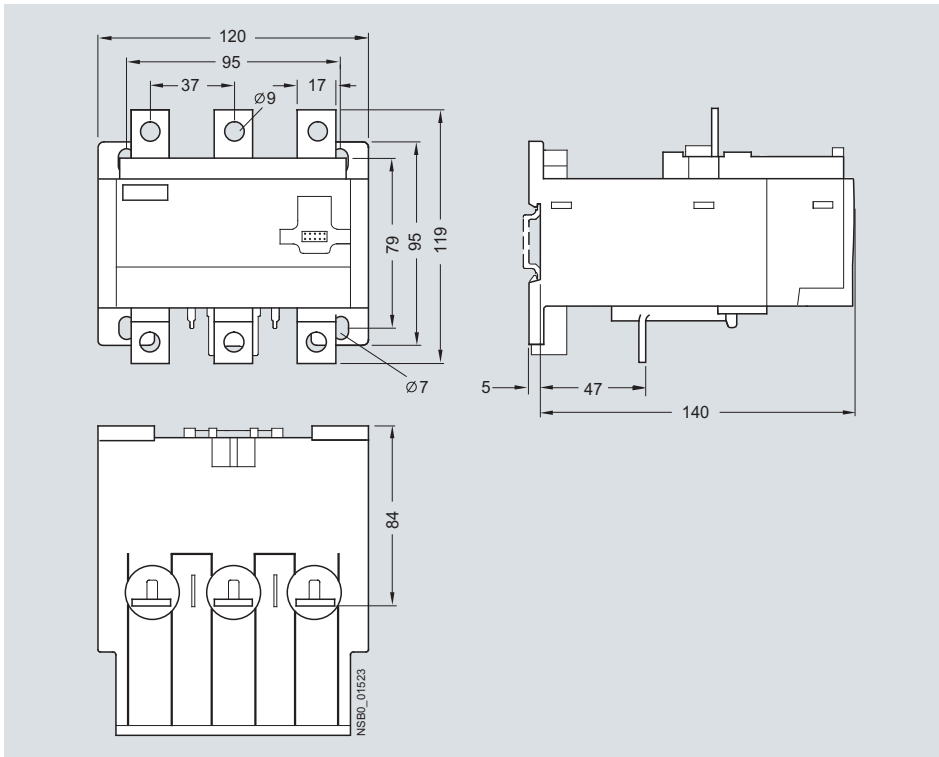

3RB29 66-2WH2 current measuring module

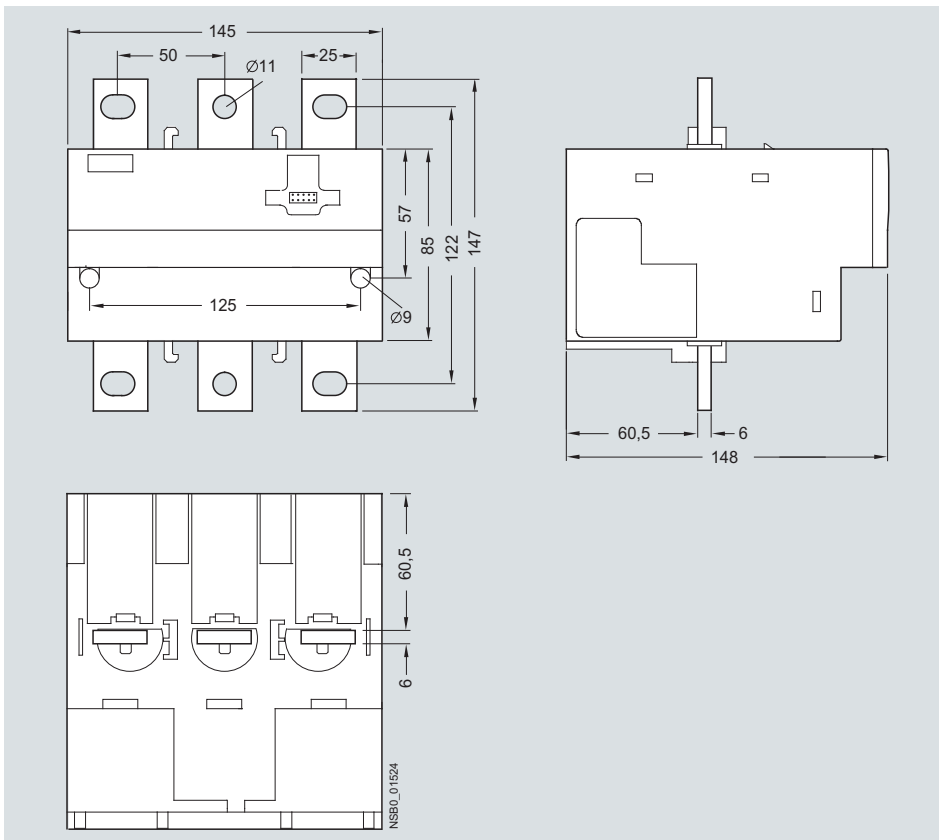

Overload Relays

3RB2 Solid-State Overload Relays

3RB22, 3RB23 for high-feature applications

Schematics

Protection of single-phase motors

(not in conjunction with internal ground-fault detection)

3RB29 06-2.G1, 3RB29 56-2TG2

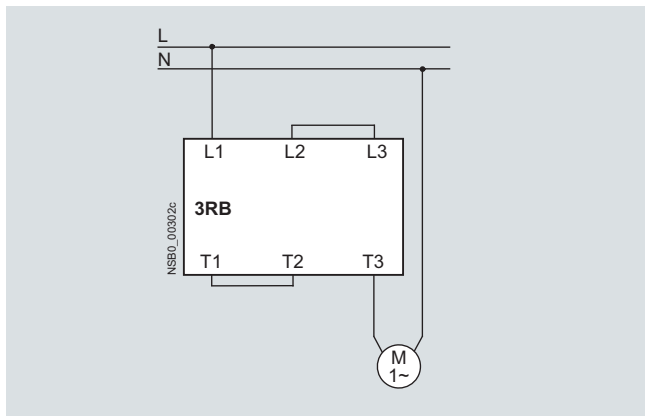

3RB29 56-2TH2, 3RB29 66-2WH2

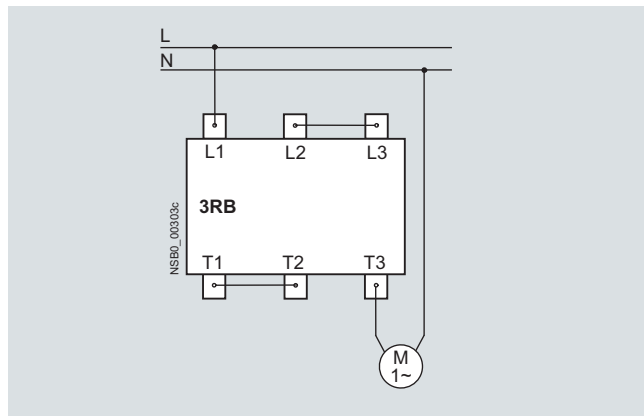

Schematic representation of a possible application (3-phase)

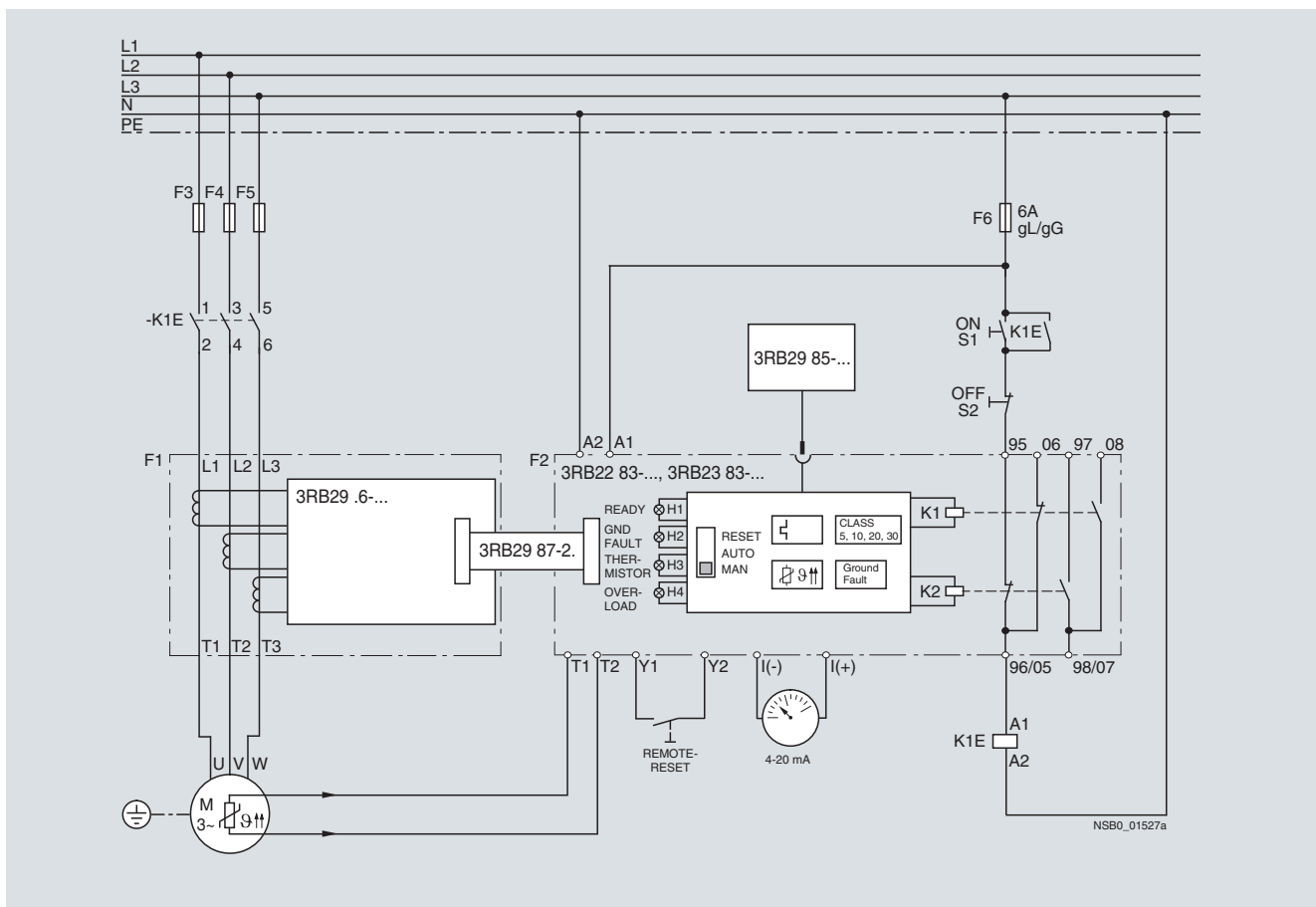

5

Overload Relays

3RB2 Solid-State Overload Relays

3RB22, 3RB23 for high-feature applications

Connections

Evaluation modules	With function expansion module	Basic functions	Inputs		
			A1/A2	T1/T2	Y1/Y2
3RB22 83-4AA1 3RB22 83-4AC1 3RB23 83-4AA1 3RB23 83-4AC1	--	Inverse-time delayed protection, temperature-dependent protection, electrical remote RESET, overload warning	Power supply 24 ... 240 V AC/DC	Connection for PTC sensor	Electrical remote RESET
	3RB29 85-2CA1	Inverse-time delayed protection, temperature-dependent protection, internal ground-fault detection, electrical remote RESET, overload warning	Power supply 24 ... 240 V AC/DC	Connection for PTC sensor	Electrical remote RESET
	3RB29 85-2CB1	Inverse-time delayed protection, temperature-dependent protection, internal ground-fault detection, electrical remote RESET, ground-fault signal	Power supply 24 ... 240 V AC/DC	Connection for PTC sensor	Electrical remote RESET
	3RB29 85-2AA0	Inverse-time delayed protection, temperature-dependent protection, electrical remote RESET, overload warning, analog output	Power supply 24 ... 240 V AC/DC	Connection for PTC sensor	Electrical remote RESET
	3RB29 85-2AA1	Inverse-time delayed protection, temperature-dependent protection, internal ground-fault detection, electrical remote RESET, overload warning, analog output	Power supply 24 ... 240 V AC/DC	Connection for PTC sensor	Electrical remote RESET
	3RB29 85-2AB1	Inverse-time delayed protection, temperature-dependent protection, internal ground-fault detection, electrical remote RESET, ground-fault signal, analog output	Power supply 24 ... 240 V AC/DC	Connection for PTC sensor	Electrical remote RESET

Evaluation modules	With function expansion module	Outputs I (-) / I (+)	Outputs			
			95/96 NC	97/98 NO	05/06 NC	07/08 NO
3RB22 83-4AA1 3RB22 83-4AC1 3RB23 83-4AA1 3RB23 83-4AC1	--	No	Disconnection of the contactor (inverse-time delayed/temperature-dependent protection)	Signal "tripped"	Overload warning	Overload warning
	3RB29 85-2CA1	No	Disconnection of the contactor (inverse-time delayed/temperature-dependent protection + ground fault)	Signal "tripped"	Overload warning	Overload warning
	3RB29 85-2CB1	No	Disconnection of the contactor (inverse-time delayed/temperature-dependent protection)	Signal "tripped"	Switching off the contactor (ground fault)	Signal "ground-fault tripping"
	3RB29 85-2AA0	Analog signal	Disconnection of the contactor (inverse-time delayed/temperature-dependent protection)	Signal "tripped"	Overload warning	Overload warning
	3RB29 85-2AA1	Analog signal	Disconnection of the contactor (inverse-time delayed/temperature-dependent protection + ground fault)	Signal "tripped"	Overload warning	Overload warning
	3RB29 85-2AB1	Analog signal	Disconnection of the contactor (inverse-time delayed/temperature-dependent protection)	Signal "tripped"	Switching off the contactor (ground fault)	Signal "ground-fault tripping"

Overload Relays

3RB2 Solid-State Overload Relays

Accessories

Overview

Overload relays for standard applications

The following accessories are available for the 3RB20/3RB21 solid-state overload relays:

- One terminal bracket each for the overload relays size S00 and S0 (sizes S2 to S12 can be installed as stand-alone installation without a terminal bracket)
- One mechanical remote RESET module for all sizes
- One cable release for resetting devices which are difficult to access (for all sizes)
- One sealable cover for all sizes
- Box terminal blocks for sizes S6 and S10/S12
- Terminal covers for sizes S2 to S10/S12

Overload relays for high-feature applications

The following accessories are available for the 3RB22/3RB23 solid-state overload relays:

- A sealable cover for the evaluation module
- Box terminal blocks for the current measuring modules size S6 and S10/S12
- Terminal covers for the current measuring modules size S6 and S10/S12

Technical specifications

Terminal brackets for stand-alone installation

Type	3RB29 13-0AA1	3RB29 23-0AA1
For overload relays	3RB20 16, 3RB21 13	3RB20 26, 3RB21 23
Size	S00	S0

General data

Type of mounting For screw and snap-on mounting onto TH 35 standard mounting rail

Connection for main circuit

Connection type



Screw terminals

• Terminal screw		Pozidriv size 2	
• Tightening torque	Nm	0.8 ... 1.2	2 ... 2.5
• Conductor cross-section (min./max.), 1 or 2 conductors			
- Solid	mm ²	1 × (0.5 ... 2.5), max. 1 × (... 4)	1 × (1 ... 6), max. 1 × (... 10)
- Finely stranded without end sleeve	mm ²	--	--
- Finely stranded with end sleeve	mm ²	1 × (0.5 ... 2.5)	1 × (1 ... 6)
- Stranded	mm ²	1 × (0.5 ... 2.5), max. 1 × (... 4)	1 × (1 ... 6), max. 1 × (... 10)
- AWG cables, solid or stranded	AWG	1 × (18 ... 14)	1 × (14 ... 10)

Motor Starters, Soft Starters and Load Feeders



6/2	Introduction	
	For Operation in the Control Cabinet	
	<u>3RW Soft Starters</u>	
6/4	General data	
6/5	3RW30 for standard applications	
6/17	3RW40 for standard applications	
6/32	3RW44 for high-feature applications	
6/52	Project planning aids	
	<u>3RA1 Fuseless Load Feeders</u>	
6/63	General data	
6/76	AS-Interface load feeder modules	
6/79	3RV19 infeed system	
6/82	Project planning aids	
	<u>3RA6 Compact Feeders</u>	
6/88	General data	
6/90	3RA61 direct-on-line starters, 3RA62 reversing starters, general data	
6/100	Accessories for 3RA6 direct-on-line and reversing starters	
6/103	Infeed systems for 3RA6	
	<u>ET 200S Motor Starters</u>	
6/110	ET 200S motor starters	
6/117	Power modules for ET 200S motor starters	
6/118	Terminal modules for ET 200S motor starters	
	<u>ET 200S Safety Motor Starters Solutions local/PROFIsafe</u>	
6/121	General data	
6/122	ET 200S Failsafe motor starters	
6/124	Safety modules local	
6/131	Safety modules PROFIsafe	
		For Operation in the Field, High Degree of Protection
		<u>ET 200pro Motor Starters</u>
6/136	Standard and High-Feature	
6/139	ET 200pro isolator modules	
6/140	Safety modules	
		<u>AS-Interface Compact Starters, 400 V AC</u>
6/142	General data	
		<u>ECOFAS^T Motor Starters and Soft Starters</u>
6/148	3RK1 3 ECOFAST motor starters and soft starters	
		<u>3RE Encapsulated Starters</u>
6/152	General data	
6/157	Project planning aids	
		AS-Interface Motor Starters and Soft Starters
		<u>Motor Starters and Load Feeders, IP65/67</u>
6/159	Motor starters, 24 V DC	

Motor Starters, Soft Starters and Load Feeders

Introduction

Overview



		Order No.	Page
For operation in the control cabinet			
<i>3RW soft starters for standard applications</i>			
	<ul style="list-style-type: none"> Application areas <ul style="list-style-type: none"> - Fans - Building/construction machines - Escalators - Air conditioning systems - Assembly lines - Actuators - Pumps - Presses - Transport systems - Fans - Compressors and coolers 		
3RW30 soft starters	<ul style="list-style-type: none"> SIRIUS 3RW30 soft starters for soft starting and smooth ramp-down of three-phase asynchronous motors Performance range of up to 55 kW (at 400 V) 	3RW30	6/5
3RW40 soft starters	<ul style="list-style-type: none"> SIRIUS 3RW40 soft starters with the integral functions <ul style="list-style-type: none"> - Solid-state motor overload and intrinsic device protection and - Adjustable current limiting For the soft starting and stopping of three-phase asynchronous motors Performance range of up to 250 kW (at 400 V) 	3RW40	6/17
<i>3RW soft starters for High-Feature applications</i>			
	<ul style="list-style-type: none"> Application areas <ul style="list-style-type: none"> - Pumps - Compressors - Industrial refrigerating systems - Conveying systems - Machine tools - Fans - Cooling systems - Water transport - Hydraulics - Mills 		
3RW44 soft starters	<ul style="list-style-type: none"> In addition to soft starting and soft ramp-down, the solid-state SIRIUS 3RW44 soft starters provide numerous functions for higher-level requirements Performance range <ul style="list-style-type: none"> - Up to 710 kW (at 400 V) in inline circuit and - Up to 1200 kW (at 400 V) in inside-delta circuit 	3RW44	6/32
<i>3RA1 load feeders</i>			
	<ul style="list-style-type: none"> The 3RA1 fuseless load feeders consist of the 3RV1 motor starter protector and the 3RT1 contactor. The motor starter protector and contactor are prewired and mechanically connected in pre-assembled assembly kits (link modules, wiring kits and standard mounting rail or busbar adapters). The motor starter protector and contactor are mechanically and electrically connected by means of the link module 4 sizes (S00, S0, S2, S3) Can be supplied for direct start or reversing duty as <ul style="list-style-type: none"> - Complete unit or - Single devices for self-assembly 		
3RA11 direct-on-line starters for snapping onto standard mounting rails or for screw fixing	<ul style="list-style-type: none"> Rated control supply voltage AC 50 Hz 230 V and 24 V DC for 35 mm standard mounting rail or screw fixing 	3RA11	6/63
3RA11 direct-on-line starters for busbar systems	<ul style="list-style-type: none"> Rated control supply voltage AC 50 Hz 230 V and 24 V DC for 40 mm and 60 mm busbar systems 	3RA11	6/63
3RA12 reversing starters for snapping onto standard mounting rails or for screw fixing	<ul style="list-style-type: none"> Rated control supply voltage AC 50 Hz 230 V and 24 V DC for 35 mm standard mounting rail or screw fixing 	3RA12	6/63
3RA12 reversing starters for busbar systems	<ul style="list-style-type: none"> Rated control supply voltage AC 50 Hz 230 V and 24 V DC for 40 mm and 60 mm busbar systems 	3RA12	6/63
3RV19 infeed system	<ul style="list-style-type: none"> Convenient means of energy supply and distribution 	3RV19	6/79
<i>3RA6 Compact Feeders</i>			
	<ul style="list-style-type: none"> Integrated functionality of a circuit breaker, contactor and solid-state overload relay and various functions of optional mountable accessories Usable for direct starting of standard induction motors up to 32 A 		
3RA61 direct-on-line starters	<ul style="list-style-type: none"> Up to 15 kW/400 V, weld-free, wide setting range, removable terminals 	3RA61	6/90
3RA62 reversing starters	<ul style="list-style-type: none"> Up to 15 kW/400 V, weld-free, wide setting range, removable terminals 	3RA62	6/90
Accessories for 3RA6 direct-on-line and reversing starters	<ul style="list-style-type: none"> Auxiliary switches, AS-i add-on modules 	3RA69	6/100
Infeed systems for 3RA6	<ul style="list-style-type: none"> Modular expandability, up to 100 A, terminals up to 70 mm² 	3RA68	6/103



3RA62

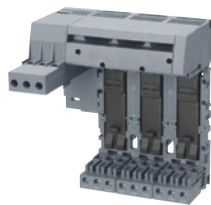

3RA68



3RK1 301



3RK1 304



3RK1 322



3RE10

Order No.	Page
-----------	------

ET 200S motor starters

ET 200S motor starters	<ul style="list-style-type: none"> Completely factory-wired motor starters for switching and protecting any AC loads, optionally as direct-on-line, reversing or soft starters 	3RK1 301	6/110
Power modules for ET 200S motor starters	<ul style="list-style-type: none"> For supplying and monitoring the auxiliary voltages for motor starters 	3RK1 903-0BA00	6/117
Terminal modules for ET 200S motor starters	<ul style="list-style-type: none"> Mechanical modules in which the motor starter and expansion modules are inserted 	3RK1 903	6/118
Interface/solid-state modules	<ul style="list-style-type: none"> Interface modules, power modules, reserve modules, digital/analog solid-state modules, F power and F solid-state modules, F terminal modules, 4 IQ-Sense sensor module, SSI module, 1 STEP step module, positioning modules, counter modules, terminal modules for power and solid-state modules 	6ES7 1	LV 1

ET 200S Safety motor starters Solutions local/PROFIsafe

ET 200S Failsafe motor starters	<ul style="list-style-type: none"> High-Feature direct-on-line and reversing starters 	3RK1 301	6/122
Safety modules local	<ul style="list-style-type: none"> For safety category 4 acc. to EN 954-1 	3RK1 903	6/124
Safety module PROFIsafe	<ul style="list-style-type: none"> Sensor and actuator assignment are freely configurable (distributed safety concept) 	3RK1 903	6/131

For operation in the field, high degree of protection

ET 200pro motor starters

ET 200pro motor starters	<ul style="list-style-type: none"> Standard and High-Feature 	3RK1 304	6/136
ET 200pro isolator modules	<ul style="list-style-type: none"> With switch disconnecter function for safe disconnection 	3RK1 304	6/139
Safety modules	<ul style="list-style-type: none"> Isolator module and 400 V disconnecting module 	3RK1 304	6/140
Accessories for ET 200pro motor starters	<ul style="list-style-type: none"> Interface, expansion and power modules 	6ES7 1	LV 1

AS-Interface compact starters, 400 V AC

	<ul style="list-style-type: none"> Completely factory-wired load feeders with degree of protection IP65, designed for switching and protecting any type of AC loads, in particular standard induction motors in direct-on-line or reversing duty 	3RK1 322	6/142
--	---	-----------------	-------

ECOFAST motor starters and soft starters

3RK1 3 ECOFAST motor starters and soft starters	<ul style="list-style-type: none"> Distributed motor starters for PROFIBUS and AS-Interface Functionality ranges from direct-on-line starters, through reversing starters and soft starters as far as frequency converters 	3RK1 3	6/148
--	--	---------------	-------

3RE encapsulated starters

	<ul style="list-style-type: none"> The 3RE1 encapsulated starters are used for switching and for the inverse-time delayed protection of load feeders up to 22 kW at 400 V AC The starters are available as direct-on-line starters for motors with a single direction of rotation and as reversing starters for motors with two directions of rotation 		
3RE10 direct-on-line starters	<ul style="list-style-type: none"> Molded-plastic enclosure, degree of protection IP65, including contactor 	3RE10	6/152
3RE13 reversing starters	<ul style="list-style-type: none"> Molded-plastic enclosure, degree of protection IP65, including contactor assembly 	3RE13	6/152
Accessories	<ul style="list-style-type: none"> Molded-plastic enclosure, degree of protection IP65, for direct-on-line and reversing starters 	3RE19	LV 1

AS-Interface motor starters and soft starters

IP65/67 motor starters and load feeders

Motor starters, 24 V DC	<ul style="list-style-type: none"> For the lowest performance range up to 70 W, 24 V DC motors and the associated sensor technology can also be directly and locally connected to AS-Interface quickly and easily. Three different versions are available: <ul style="list-style-type: none"> - Single direct-on-line starters - Double direct-on-line starters - Reversing starters 	3RK1 400-1	6/159
--------------------------------	---	-------------------	-------

For Operation in the Control Cabinet

3RW Soft Starters

General data

Overview

The advantages of the SIRIUS soft starters at a glance:

- Soft starting and smooth ramp-down¹⁾
- Stepless starting
- Reduction of current peaks
- Avoidance of mains voltage fluctuations during starting
- Reduced load on the power supply network
- Reduction of the mechanical load in the operating mechanism
- Considerable space savings and reduced wiring compared with conventional starters
- Maintenance-free switching
- Very easy handling
- Fits perfectly in the SIRIUS modular system



		SIRIUS 3RW30 Standard applications	SIRIUS 3RW40 Standard applications	SIRIUS 3RW44 High-Feature applications
Rated current up to 40 °C	A	3 ... 106	12.5 ... 432	29 ... 1214
Rated operational voltage	V	200 ... 480	200 ... 600	200 ... 690
Motor rating at 400 V				
• Inline circuit	kW	1.5 ... 55	5.5 ... 250	15 ... 710
• Inside-delta circuit	kW	--	--	22 ... 1200
Ambient temperature	°C	-25 ... +60	-25 ... +60	0 ... +60
Soft starting/ramp-down		✓ ¹⁾	✓	✓
Voltage ramp		✓	✓	✓
Starting/stopping voltage	%	40 ... 100	40 ... 100	20 ... 100
Starting and ramp-down time	s	0 ... 20	0 ... 20	1 ... 360
Torque control		--	--	✓
Starting/stopping torque	%	--	--	20 ... 100
Torque limit	%	--	--	20 ... 200
Ramp time	s	--	--	1 ... 360
Integral bypass contact system		✓	✓	✓
Intrinsic device protection		--	✓	✓
Motor overload protection		--	✓	✓
Thermistor motor protection		--	✓ ²⁾	✓
Integrated remote RESET		--	✓ ³⁾	✓
Adjustable current limiting		--	✓	✓
Inside-delta circuit		--	--	✓
Breakaway pulse		--	--	✓
Creep speed in both directions of rotation		--	--	✓
Pump ramp-down		--	--	✓ ⁴⁾
DC braking		--	--	✓ ⁴⁾ 5)
Combined braking		--	--	✓ ⁴⁾ 5)
Motor heating		--	--	✓
Communication		--	--	With PROFIBUS DP (optional)
External display and operator module		--	--	(optional)
Operating measured value display		--	--	✓
Error logbook		--	--	✓
Event list		--	--	✓
Slave pointer function		--	--	✓
Trace function		--	--	✓ ⁶⁾
Programmable control inputs and outputs		--	--	✓
Number of parameter sets		1	1	3
Parameterization software (Soft Starter ES)		--	--	✓
Power semiconductors (thyristors)		2 controlled phases	2 controlled phases	3 controlled phases
Screw terminals		✓	✓	✓
Spring-type terminals		✓	✓	✓
UL/CSA		✓	✓	✓
CE marking		✓	✓	✓
Soft starting under heavy starting conditions		--	--	✓ ⁴⁾

Configuring support

Win-Soft Starter, electronic selection slider ruler, Technical Assistance ++49 (0) 911 895 5900

✓ Function is available; -- Function is not available.

¹⁾ Only soft starting available for 3RW30.

²⁾ Optional up to size S3 (device variant).

³⁾ Available for 3RW40 2. to 3RW40 4.; optional for 3RW40 5. and 3RW40 7..

⁴⁾ Calculate soft starter and motor with size allowance where required.

⁵⁾ Not possible in inside-delta circuit.

⁶⁾ Trace function with Soft Starter ES software.

More information can be found on the Internet at

<http://www.siemens.com/softstarter>

For Operation in the Control Cabinet

3RW Soft Starters

3RW30 for standard applications

Overview

The SIRIUS 3RW30 soft starters reduce the motor voltage through variable phase control and increase it in ramp-like mode from a selectable starting voltage up to mains voltage. During starting, these devices limit the torque as well as the current and prevent the shocks which arise during direct starts or wye-delta starts. In this way, mechanical loads and mains voltage dips can be reliably reduced.

Soft starting reduces the stress on the connected equipment and results in lower wear and therefore longer periods of trouble-free production. The selectable start value means that the soft starters can be adjusted individually to the requirements of the application in question and unlike wye-delta starters are not restricted to two-stage starting with fixed voltage ratios.

The SIRIUS 3RW30 soft starters are characterized above all by their small space requirements. Integrated bypass contacts mean that no power loss has to be taken into the bargain at the power semiconductors (thyristors) after the motor has started up. This cuts down on heat losses, enabling a more compact design and making external bypass circuits superfluous.

Various versions of the SIRIUS 3RW30 soft starters are available:

- Standard version for fixed-speed three-phase motors, sizes S00, S0, S2 and S3, with integrated bypass contact system
- Version for fixed-speed three-phase motors in a 22.5 mm enclosure without bypass

Soft starters rated up to 55 kW (at 400 V) for standard applications in three-phase networks are available. Extremely small sizes, low power losses and simple commissioning are just three of the many advantages of this soft starter.

Function

The space required by the compact SIRIUS 3RW30 soft starter is often only about one third of that required by a contactor assembly for wye-delta starting of comparable rating. This not only saves space in the control cabinet and on the standard mounting rail but also does away completely with the wiring work needed for wye-delta starters. This is notable in particular for higher motor ratings which are only rarely available as fully wired solutions.

At the same time the number of cables from the starter to the motor is reduced from six to three. Compact dimensions, short start-up times, easy wiring and fast commissioning make themselves felt as clear-cut cost advantages.

The bypass contacts of these soft starters are protected during operation by an integrated solid-state arc quenching system. This prevents damage to the bypass contacts in the event of a fault, e. g. brief disconnection of the control voltage, mechanical shocks or life-related component defects on the coil operating mechanism or main contact spring.

The new series of devices comes with the "polarity balancing" control method, which is designed to prevent direct current components in two-phase controlled soft starters. On two-phase controlled soft starters the current resulting from superimposition of the two controlled phases flows in the uncontrolled phase. This results for physical reasons in an asymmetric distribution of the three phase currents during the motor ramp-up. This phenomenon cannot be influenced, but in most applications it is non-critical.

Controlling the power semiconductors results not only in this unbalance, however, but also in the previously mentioned direct current components which can cause severe noise generation on the motor at starting voltages of less than 50 %. The control method used for these soft starters eliminates these direct current components during the ramp-up phase and prevents the braking torque which they can cause.

It creates a motor ramp-up that is uniform in speed, torque and current rise, thus permitting a particularly gentle, two-phase starting of the motors. At the same time the acoustic quality of the starting operation comes close to the quality of a three-phase controlled soft starter. This is made possible by the on-going dynamic harmonizing and balancing of current half-waves of different polarity during the motor ramp-up. Hence the name "polarity balancing".

- Soft starting with voltage ramp; the starting voltage setting range U_s is 40 % to 100 % and the ramp time t_R can be set from 0 s to 20 s
- Integrated bypass contact system to minimize power loss
- Setting with two potentiometers
- Simple mounting and commissioning
- Mains voltages at 50/60 Hz, 200 to 480 V
- Two control voltage versions 24 V AC/DC and 110 to 230 V AC/DC
- Wide temperature range from -25 °C to +60 °C
- The built-in auxiliary contact ensures user-friendly control and possible further processing within the system ([for status graphs see 6/16](#))

For Operation in the Control Cabinet

3RW Soft Starters

3RW30 for standard applications

Technical specifications

Type	3RW30 1., 3RW30 2.		3RW30 3., 3RW30 4.			
Control electronics						
Rated values	Terminal A1/A2	V	24	110 ... 230	24	110 ... 230
Rated control supply voltage		%	±20	-15/+10	±20	-15/+10
• Tolerance						
Rated control supply current		mA	< 50	6	20	< 50
• STANDBY		mA	< 100	15	< 4000	< 500
• During pick-up		mA	< 100	15	20	< 50
• ON						
Rated frequency		Hz	50/60			
• Tolerance		%	±10			
Control input						
IN			ON/OFF			
Power consumption with version		mA	Approx. 12			
• 24 V DC		mA	AC: 3/6; DC: 1.5/3			
• 110/230 V AC						
Relay outputs						
Output 1	ON	13/14	Operating indication (NO)			
Rated operational current		A	3 AC-15/AC-14 at 230 V, 1 DC-13 at 24 V			
Protection against overvoltages			Protection by means of varistor through contact			
Short-circuit protection			4 A gL/gG operational class; 6 A quick (fuse is not included in scope of supply)			
Operating indications						
		LEDs	DEVICE	STATE/BYPASSED/ FAILURE	DEVICE	STATE/BYPASSED/ FAILURE
Off			Green	Off	Green	Off
Start			Green	Green flashing	Green	Green flashing
Bypass			Green	Green	Green	Green
Error signals						
• 24 V DC:			Off	Red	Off	Red
$U < 0.75 \times U_s$ or $U > 1.25 \times U_s$			Off	Red	Off	Red
• 110 ... 230 V AC:						
$U < 0.75 \times U_s$ or $U > 1.15 \times U_s$			Yellow	Red	--	--
Electrical overloading of bypass (reset by removing IN command)			Green	Red	Green	Red
Missing mains voltage, phase failure, missing load			Red	Red	Red	Red
Device fault						
Control times and parameters						
Control times						
Closing time (with connected control voltage)		ms	< 50			
Closing time (automatic/mains contactor mode)		ms	< 300			
Mains failure bridging time						
Control supply voltage		ms	50			
Mains failure response time¹⁾						
Load circuit		ms	500			
Starting parameters						
• Starting time		s	0 ... 20		7.5	
• Starting voltage		%	40 ... 100		40	
Start-up detection						
			No			
Operating mode output 13/14						
Rising edge at		Start command	ON			
Falling edge at		Off command				

¹⁾ Mains failure detection only in standby state, not during operation.

For Operation in the Control Cabinet

3RW Soft Starters

3RW30 for standard applications

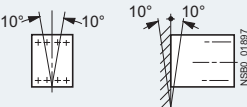
Type	3RW30 1.-.BB.4 ... 3RW30 4.-.BB.4	
Power electronics		
Rated operational voltage	V AC	200 ... 480
Tolerance	%	-15/+10
Rated frequency	Hz	50/60
Tolerance	%	±10
Uninterrupted duty at 40 °C (% of I_e)	%	115
Minimum load (% of I_e)	%	10 (at least 2 A)
Maximum cable length between soft starter and motor	m	300
Permissible installation height	m	5000 (derating from 1000, see characteristic curves); higher on request
Permissible mounting position (auxiliary fan not available)		
Permissible ambient temperature	°C	-25 ... +60; (derating from +40)
Operation	°C	-40 ... +80
Storage		
Degree of protection	IP20 for 3RW30 1. and 3RW30 2.; IP00 for 3RW30 3. and 3RW30 4.	

Type	3RW30 13	3RW30 14	3RW30 16	3RW30 17	3RW30 18	
Power electronics						
Load rating with rated operational current I_e						
• Acc. to IEC and UL/CSA ¹⁾ , for individual mounting, AC-53a						
- At 40 °C	A	3.6	6.5	9	12.5	17.6
- At 50 °C	A	3.3	6	8	12	17
- At 60 °C	A	3	5.5	7	11	14
Power loss						
• In operation after completed starting with uninterrupted rated operational current (40 °C) approx.						
	W	0.25	0.5	1	2	4
• During starting with 300 % I_M (40 °C)						
	W	6	13	20	20	29
Permissible rated motor current and starts per hour for normal starting (Class 10)						
- Rated motor current $I_M^{(2)}$, starting time 3 s						
	A	3.6	6.5	9	12.5	17.6
- Starts per hour ³⁾						
	1/h	200	87	50	85	62
- Rated motor current $I_M^{(2)}$, starting time 4 s						
	A	3.6	6.5	9	12.5	17.6
- Starts per hour ³⁾						
	1/h	150	64	35	62	45

¹⁾ Measurement at 60 °C according to UL/CSA not required.

²⁾ With 300 % I_M .

³⁾ For intermittent duty S4 with ON period = 30 %, $T_U = 40$ °C, stand-alone installation vertical. The quoted switching frequencies do not apply for automatic mode.

Type	3RW30 26	3RW30 27	3RW30 28	
Power electronics				
Load rating with rated operational current I_e				
• Acc. to IEC and UL/CSA ¹⁾ , for individual mounting, AC-53a				
- At 40 °C	A	25.3	32.2	38
- At 50 °C	A	23	29	34
- At 60 °C	A	21	26	31
Power loss				
• In operation after completed starting with uninterrupted rated operational current (40 °C) approx.				
	W	8	13	19
• During starting with 300 % I_M (40 °C)				
	W	47	55	64
Permissible rated motor current and starts per hour for normal starting (Class 10)				
- Rated motor current $I_M^{(2)}$, starting time 3 s				
	A	25	32	38
- Starts per hour ³⁾				
	1/h	23	23	19
- Rated motor current $I_M^{(2)}$, starting time 4 s				
	A	25	32	38
- Starts per hour ³⁾				
	1/h	15	16	12

¹⁾ Measurement at 60 °C according to UL/CSA not required.

²⁾ With 300 % I_M .

³⁾ For intermittent duty S4 with ON period = 30 %, $T_U = 40$ °C, stand-alone installation vertical. The quoted switching frequencies do not apply for automatic mode.

For Operation in the Control Cabinet

3RW Soft Starters

3RW30 for standard applications

Type		3RW30 36	3RW30 37	3RW30 38	3RW30 46	3RW30 47
Power electronics						
Load rating with rated operational current I_e						
• Acc. to IEC and UL/CSA ¹⁾ , for individual mounting, AC-53a						
- At 40 °C	A	45	65	72	80	106
- At 50 °C	A	42	58	62.1	73	98
- At 60 °C	A	39	53	60	66	90
Power loss						
• In operation after completed starting with uninterrupted rated operational current (40 °C) approx.	W	6	12	15	12	21
• During starting with 300 % I_M (40 °C)	W	79	111	125	144	192
Permissible rated motor current and starts per hour for normal starting (Class 10)						
- Rated motor current $I_M^{2)}$, starting time 3 s	A	45	63	72	80	106
- Starts per hour ³⁾	1/h	38	23	22	22	15
- Rated motor current $I_M^{2)}$, starting time 4 s	A	45	63	72	80	106
- Starts per hour ³⁾	1/h	26	15	15	15	10

1) Measurement at 60 °C according to UL/CSA not required.



2) With 300 % I_M .

3) For intermittent duty S4 with ON period = 70 %, $T_u = 40$ °C, stand-alone installation vertical. The quoted switching frequencies do not apply for automatic mode.

For Operation in the Control Cabinet

3RW Soft Starters

3RW30 for standard applications

Soft starters	Type		3RW30 1.	3RW30 2.	3RW30 3.	3RW30 4.
Conductor cross-sections						
Screw terminals	Main conductors					
Front clamping point connected 	• Solid	mm ²	2 x (1 ... 2.5); 2 x (2.5 ... 6) acc. to IEC 60947	2 x (1 ... 2.5); 2 x (2.5 ... 6) acc. to IEC 60947; max. 1 x 10	2 x (1.5 ... 16)	2 x (2.5 ... 16)
	• Finely stranded with end sleeve	mm ²	2 x (1.5 ... 2.5); 2 x (2.5 ... 6)	2 x (1 ... 2.5); 2 x (2.5 ... 6)	1 x (0.75 ... 25)	1 x (2.5 ... 35)
	• Stranded	mm ²	--	--	1 x (0.75 ... 35)	1 x (4 ... 70)
	• AWG cables - Solid - Solid or stranded - Stranded	AWG AWG AWG	2 x (16 ... 12) 2 x (14 ... 10) 1 x 8	2 x (16 ... 12) 2 x (14 ... 10) 1 x 8	1 x (18 ... 2) --	1 x (10 ... 2/0) --
Rear clamping point connected 	• Solid	mm ²	--	--	2 x (1.5 ... 16)	2 x (2.5 ... 16)
	• Finely stranded with end sleeve	mm ²	--	--	1 x (1.5 ... 25)	1 x (2.5 ... 50)
	• Stranded	mm ²	--	--	1 x (1.5 ... 35)	1 x (10 ... 70)
	• AWG cables - Solid or stranded	AWG	--	--	1 x (16 ... 2)	1 x (10 ... 2/0)
Both clamping points connected 	• Solid	mm ²	--	--	2 x (1.5 ... 16)	2 x (2.5 ... 16)
	• Stranded	mm ²	--	--	2 x (1.5 ... 25)	2 x (10 ... 50)
	• Finely stranded with end sleeve	mm ²	--	--	2 x (1.5 ... 16)	2 x (2.5 ... 35)
	• AWG cables - Solid or stranded	AWG	--	--	2 x (16 ... 2)	2 x (10 ... 1/0)
	• Tightening torque	NM lb.in	2 ... 2.5 18 ... 22	2 ... 2.5 18 ... 22	4.5 40	6.5 58
	Tools		PZ 2	PZ 2	PZ 2	Allen screw 4 mm
	Degree of protection		IP20	IP20	IP20 (IP00 terminal compartment)	IP20 (IP00 terminal compartment)
Spring-type terminals	Main conductors					
	• Solid	mm ²	1 ... 4	1 ... 10	--	--
	• Finely stranded with end sleeve	mm ²	1 ... 2.5	1 ... 6, end sleeves without plastic collar	--	--
	• AWG cables - Solid or stranded (finely stranded) - Stranded	AWG AWG	16 ... 14 16 ... 12	16 ... 10 1 x 8	-- --	-- --
	Tools		DIN ISO 2380-1A0; 5 x 3	DIN ISO 2380-1A0; 5 x 3	--	--
	Degree of protection		IP20	IP20	--	--
Busbar connections	Main conductors					
	• With cable lug acc. to DIN 46234 or max. 20 mm wide					
	- Stranded	mm ²	--	--	--	2 x (10 ... 70)
	- Finely stranded	mm ²	--	--	--	2 x (10 ... 50)
	• AWG cables, solid or stranded	AWG	--	--	--	2 x (7 ... 1/0)

Soft starters	Type		3RW30 1. ... 3RW30 4.
Conductor cross-sections			
Auxiliary conductors (1 or 2 conductors can be connected):			
Screw terminals			
	• Solid	mm ²	2 x (0.5 ... 2.5)
	• Finely stranded with end sleeve	mm ²	2 x (0.5 ... 1.5)
	• AWG cables - Solid or stranded - Finely stranded with end sleeve	AWG AWG	2 x (20 ... 14) 2 x (20 ... 16)
	• Terminal screws - Tightening torque	NM lb.in	0.8 ... 1.2 7 ... 10.3
Spring-type terminals			
	• Solid	mm ²	2 x (0.25 ... 2.5)
	• Finely stranded with end sleeve	mm ²	2 x (0.25 ... 1.5)
	• AWG cables, solid or stranded	AWG	2 x (24 ... 14)

For Operation in the Control Cabinet

3RW Soft Starters

3RW30 for standard applications

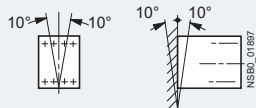
Type	3RW30 03	
Control electronics		
Rated values		
Rated control supply voltage	V	24 ... 230 AC/DC
• Tolerance	%	± 10
Rated control supply current	mA	25 ... 4
Rated frequency at AC	Hz	50/60
• Tolerance	%	± 10
Starting time	s	0.1 ... 20 (adjustable)
Starting voltage	%	40 ... 100 (adjustable)
Ramp-down time	s	0 ... 20 (adjustable)
Power electronics		
Rated operational voltage	V AC	200 ... 400
Tolerance	%	± 10
Rated frequency	Hz	50/60
Tolerance	%	±10
Uninterrupted duty (% of I_e)	%	100
Minimum load ¹⁾ (% of I_e); at 40 °C	%	9
Maximum conductor length between soft starter and motor	m	100 ²⁾
Degree of protection acc. to IEC 60529		IP20 (IP00 terminal compartment)
Permissible installation height	m	5000 (derating from 1000, see characteristic curves); higher on request
Permissible mounting position		
Permissible ambient temperature		
Operation	°C	-25 ... +60; (derating from +40)
Storage	°C	-40 ... +80
Load rating with rated operational current I_e		
• Acc. to IEC and UL/CSA ¹⁾ , for individual mounting, AC-53a		
- At 40 °C	A	3
- At 50 °C	A	2.6
- At 60 °C	A	2.2
• Acc. to IEC and UL/CSA ¹⁾ , for butt-mounting, AC-53a		
- At 40 °C	A	2.6
- At 50 °C	A	2.2
- At 60 °C	A	1.8
Power loss		
• In operation after completed starting with uninterrupted rated operational current (40 °C) approx.	W	6.5
• At utilization of max. switching frequency	W	3
Permissible starts per hour		
• For intermittent duty S4, $T_u = 40$ °C, stand-alone installation vertical	1/h	1500
• ON period = 70 %	% I_e /s	300/0.2
Conductor cross-sections		
Screw terminals (1 or 2 conductors connectable) For standard screwdriver size 2 and Pozidriv 2	• Main conductors	
	- Solid	mm ² 1 x (0.5 ... 4); 2 x (0.5 ... 2.5)
	- Finely stranded with end sleeve	mm ² 1 x (0.5 ... 2.5); 2 x (0.5 ... 1.5)
	- Stranded	mm ² --
	- AWG cables, solid or stranded	AWG 2 x (20 ... 14)
	- Terminal screws	M3, PZ2
	- Tightening torque	NM 0.8 ... 1.2 lb.in 7.1 ... 8.9
	• Auxiliary conductors	
	- Solid	mm ² 1 x (0.5 ... 4); 2 x (0.5 ... 2.5)
	- Finely stranded with end sleeve	mm ² 1 x (0.5 ... 2.5); 2 x (0.5 ... 1.5)
	- AWG cables, solid or stranded	AWG 2 x (20 ... 14)
	- Terminal screws	M3, PZ2
	- Tightening torque	NM 0.8 ... 1.2 lb.in 7 ... 8.9
Spring-type terminals	Main and auxiliary conductors	
	• Solid	mm ² 2 x (0.25 ... 1.5)
	• Finely stranded with end sleeve	mm ² 2 x (0.25 ... 1)
	• AWG cables, solid or stranded	mm ² 2 x (24 ... 16)

¹⁾ The rated motor current (specified on the motor's name plate) should at least amount to the specified percentage of the SIRIUS soft starter unit's rated operational current I_e .

²⁾ If this value is exceeded, problems with line capacities may arise, which can result in false firing.

For Operation in the Control Cabinet

3RW Soft Starters

3RW30 for standard applications

	Standard	Parameters
Electromagnetic compatibility Acc. to EN 60947-4-2		
<i>EMC interference immunity</i>		
Electrostatic discharge (ESD)	EN 61000-4-2	±4 kV contact discharge, ±8 kV air discharge
Electromagnetic RF fields	EN 61000-4-3	Frequency range: 80 ... 2000 MHz with 80 % at 1 kHz Degree of severity 3: 10 V/m
Conducted RF interference	EN 61000-4-6	Frequency range: 150 kHz ... 80 MHz with 80 % at 1 kHz Interference 10 V
RF voltages and RF currents on cables		
• Burst	EN 61000-4-4	±2 kV/5 kHz
• Surge	EN 61000-4-5	±1 kV line to line ±2 kV line to earth
<i>EMC interference emission</i>		
EMC interference field strength	EN 55011	Limit value of Class A at 30 ... 1000 MHz, limit value of Class B for 3RW30 2.; 24 V AC/DC
Radio interference voltage	EN 55011	Limit value of Class A at 0.15 ... 30 MHz, limit value of Class B for 3RW30 2.; 24 V AC/DC
<i>Radio interference suppression filters</i>		
Degree of noise suppression A (Industrial applications)	Not required	
Degree of noise suppression B (applications for residential areas)	Not available ¹⁾	
Control voltage	Not required for 3RW30 1. and 3RW30 2.;	
• 230 V AC/DC	required for 3RW30 3. and 3RW30 4. (see Table)	
• 24 V AC/DC		

¹⁾ Degree of noise suppression B cannot be obtained through the use of filters as the strength of the electromagnetic field is not attenuated by the filter.

Soft starter type	Rated current Soft starters A	Recommended filters ¹⁾		
		Voltage range 200 ... 480 V		
		Filter type	Rated current filters A	Terminals mm ²
3RW30 36	45	4EF1512-1AA10	50	16
3RW30 37	63	4EF1512-2AA10	66	25
3RW30 38	72	4EF1512-3AA10	90	25
3RW30 46	80	4EF1512-3AA10	90	25
3RW30 47	106	4EF1512-4AA10	120	50

¹⁾ The radio interference suppression filter is used to remove the conducted interference from the main circuit. The field-related emissions comply with degree of noise suppression B. Filter selection applies under standard conditions: 10 starts per hour, start time 4 s at 300 % I_e .

For Operation in the Control Cabinet

3RW Soft Starters

3RW30 for standard applications

Fuse assignment

The type of coordination to which the motor feeder with soft starter is mounted depends on the application-specific requirements. Normally, fuseless mounting (combination of motor starter protector/circuit breaker and soft starter) is sufficient.

If type of coordination "2" is to be fulfilled, semiconductor fuses must be fitted in the motor feeder.

Fuseless version

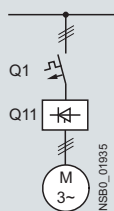

Soft starters		Motor starter protectors ¹⁾		
Q11 Type	Rated current A	Q1 Type	$I_{q \max}$ kA	Rated current A
Type of coordination "1"ⁿ²⁾				
3RW30 03	3	3RV10 11-1EA10	50	4
3RW30 13	3.6	3RV10 21-1FA10	10	5
3RW30 14	6.5	3RV10 21-1HA10	10	8
3RW30 16	9	3RV10 21-1JA10	10	10
3RW30 17	12.5	3RV10 21-1KA10	10	12.5
3RW30 18	17.6	3RV10 21-4BA10	10	20
3RW30 26	25	3RV10 21-4DA10	55	25
3RW30 27	32	3RV10 31-4EA10	55	32
3RW30 28	38	3RV10 31-4FA10	55	40
3RW30 36	45	3RV10 31-4GA10	20	45
3RW30 37	63	3RV10 41-4JA10	20	63
3RW30 38	72	3RV10 41-4KA10	20	75
3RW30 46	80	3RV10 41-4LA10	11	90
3RW30 47	106	3RV10 41-4MA10	11	100

¹⁾ The rated motor current must be considered when selecting the devices.

²⁾ The types of coordination are explained in more detail under "3RA1 Fuseless Load Feeders".

Fused version (line protection only)

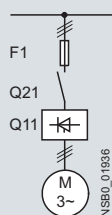

Soft starters		Line protection, maximum			Line contactors
Q11 Type	Rated current A	F1 Type	Rated current A	Size	Q21 (optional)
Type of coordination "1"ⁿ¹⁾: $I_q = 65 \text{ kA at } 480 \text{ V } 10 \%$					
3RW30 03 ²⁾	3	3NA3 805 ³⁾	20	000	3RT10 15
3RW30 13	3.6	3NA3 803-6	10	000	3RT10 15
3RW30 14	6.5	3NA3 805-6	16	000	3RT10 15
3RW30 16	9	3NA3 807-6	20	000	3RT10 16
3RW30 17	12.5	3NA3 810-6	25	000	3RT10 24
3RW30 18	17.6	3NA3 814-6	35	000	3RT10 26
3RW30 26	25	3NA3 822-6	63	00	3RT10 26
3RW30 27	32	3NA3 824-6	80	00	3RT10 34
3RW30 28	38	3NA3 824-6	80	00	3RT10 35
3RW30 36	45	3NA3 130-6	100	1	3RT10 36
3RW30 37	63	3NA3 132-6	125	1	3RT10 44
3RW30 38	72	3NA3 132-6	125	1	3RT10 45
3RW30 46	80	3NA3 136-6	160	1	3RT10 45
3RW30 47	106	3NA3 136-6	160	1	3RT10 46

¹⁾ The types of coordination are explained in more detail under "3RA1 Fuseless Load Feeders".

The type of coordination "1" refers only to soft starters in combination with the stipulated protective device (motor starter protector/circuit

breaker/fuse), not to any additional components in the feeder.

²⁾ $I_q = 50 \text{ kA at } 400 \text{ V}$.

³⁾ 3NA3 805-1 (LV HRC00), 5SB2 61 (DIAZED), 5SE2 201-6 (NEOZED).

For Operation in the Control Cabinet

3RW Soft Starters

3RW30 for standard applications

Fused version with 3NE1 SITOR fuses (semiconductor and line protection)

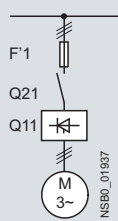

For matching fuse bases see Catalog LV 1 under "SENTRON Switching and Protection Devices for Power Distribution" → "Switch Disconnectors", and Catalog ET B1 under "BETA Protecting" → "SITOR Semiconductor Fuses" or go to www.siemens.com/sitor → "Products" → "BETA Protecting" → "SITOR"

Soft starters		All-range fuses		Line contactors	
^{ToC} 2	Rated current	F'1 Type	Rated current	Size	(optional) Q21
Q11 Type	A	Type	A		
Type of coordination "2"¹⁾: $I_q = 65 \text{ kA at } 480 \text{ V } 10 \%$					
3RW30 03²⁾	3	3NE1 813-0 ³⁾	16	000	3RT10 15
3RW30 13	3.6	3NE1 813-0	16	000	3RT10 15
3RW30 14	6.5	3NE1 813-0	16	000	3RT10 15
3RW30 16	9	3NE1 813-0	16	000	3RT10 16
3RW30 17	12.5	3NE1 813-0	16	000	3RT10 24
3RW30 18	17.6	3NE1 814-0	20	000	3RT10 26
3RW30 26	25	3NE1 803-0	35	000	3RT10 26
3RW30 27	32	3NE1 020-2	80	00	3RT10 34
3RW30 28	38	3NE1 020-2	80	00	3RT10 35
3RW30 36	45	3NE1 020-2	80	00	3RT10 36
3RW30 37	63	3NE1 820-0	80	000	3RT10 44
3RW30 38	72	3NE1 820-0	80	000	3RT10 45
3RW30 46	80	3NE1 021-0	100	00	3RT10 45
3RW30 47	106	3NE1 022-0	125	00	3RT10 46

1) The types of coordination are explained in more detail under "3RA1 Fuseless Load Feeders".

The type of coordination "2" refers only to soft starters in combination with the stipulated protective device (motor starter protector/circuit breaker/fuse), not to any additional components in the feeder.

2) $I_q = 50 \text{ kA at } 400 \text{ V}$.

3) No SITOR fuse required!
Alternatively: 3NA3 803 (LV HRC00), 5SB2 21 (DIAZED), 5SE2 206 (NEOZED).

^{ToC}
1 Type of coordination "1"

^{ToC}
2 Type of coordination "2"

The types of coordination are explained in more detail under "3RA1 Fuseless Load Feeders".

These types of coordination are indicated in the Technical specifications by orange backgrounds.

For Operation in the Control Cabinet

3RW Soft Starters

3RW30 for standard applications

Fused version with 3NE3 SITOR fuses (semiconductor protection by fuse, line and overload protection by motor starter protector; alternatively, installation with contactor and overload relay possible)

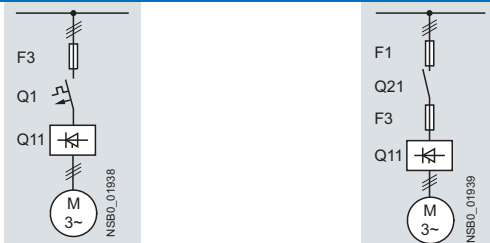

For matching fuse bases see Catalog LV 1 under "SENTRON Switching and Protection Devices for Power Distribution" —> "Switch Disconnectors", and Catalog ET B1 under "BETA Protecting" —> "SITOR Semiconductor Fuses" or go to www.siemens.com/sitor —> "Products" —> "BETA Protecting" —> "SITOR"

Soft starters ToC 2 Q11 Type	Rated current A	Semiconductor fuses, minimum		Semiconductor fuses, maximum		Semiconductor fuses, minimum		
		F3 Type	Rated current A	Size	F3 Type	Rated current A	Size	F3 Type

Type of coordination "2" ¹⁾ : I _q = 65 kA at 480 V 10 %											
3RW30 03 ²⁾	3	--	--	--	--	--	--	--	--	--	
3RW30 13	3.6	--	--	--	--	--	--	3NE4 101	32	0	
3RW30 14	6.5	--	--	--	--	--	--	3NE4 101	32	0	
3RW30 16	9	--	--	--	--	--	--	3NE4 101	32	0	
3RW30 17	12.5	--	--	--	--	--	--	3NE4 101	32	0	
3RW30 18	17.6	--	--	--	--	3NE3 221	100	1	3NE4 101	32	0
3RW30 26	25	--	--	--	--	3NE3 221	100	1	3NE4 102	40	0
3RW30 27	32	--	--	--	--	3NE3 222	125	1	3NE4 118	63	0
3RW30 28	38	--	--	--	--	3NE3 222	125	1	3NE4 118	63	0
3RW30 36	45	--	--	--	--	3NE3 224	160	1	3NE4 120	80	0
3RW30 37	63	--	--	--	--	3NE3 225	200	1	3NE4 121	100	0
3RW30 38	72	3NE3 221	100	1	3NE3 227	250	1	--	--	--	--
3RW30 46	80	3NE3 222	125	1	3NE3 225	200	1	--	--	--	--
3RW30 47	106	3NE3 224	160	1	3NE3 231	350	1	--	--	--	--

Soft starters ToC 2 Q11 Type	Rated current A	Semiconductor fuses max.			Semiconductor fuses min.			Semiconductor fuses max.			Cylindrical fuses	
		F3 Type	Rated current A	Size	F3 Type	Rated current A	Size	F3 Type	Rated current A	Size	F3 Type	Rated current A

Type of coordination "2" ¹⁾ : I _q = 65 kA at 480 V 10 %												
3RW30 03 ²⁾	3	--	--	--	3NE8 015-1	25	00	3NE8 015-1	25	00	3NC1 010	10
3RW30 13	3.6	--	--	--	3NE8 015-1	25	00	3NE8 015-1	25	00	3NC2 220	20
3RW30 14	6.5	--	--	--	3NE8 015-1	25	00	3NE8 015-1	25	00	3NC2 220	20
3RW30 16	9	--	--	--	3NE8 015-1	25	00	3NE8 015-1	25	00	3NC2 220	20
3RW30 17	12.5	--	--	--	3NE8 015-1	25	00	3NE8 018-1	63	00	3NC2 250	50
3RW30 18	17.6	--	--	--	3NE8 003-1	35	00	3NE8 021-1	100	00	3NC2 263	63
3RW30 26	25	3NE4 117	50	0	3NE8 017-1	50	00	3NE8 021-1	100	00	3NC2 263	63
3RW30 27	32	3NE4 118	63	0	3NE8 018-1	63	00	3NE8 022-1	125	00	3NC2 280	80
3RW30 28	38	3NE4 118	63	0	3NE8 020-1	80	00	3NE8 022-1	125	00	3NC2 280	80
3RW30 36	45	3NE4 120	80	0	3NE8 020-1	80	00	3NE8 024-1	160	00	3NC2 280	80
3RW30 37	63	3NE4 121	100	0	3NE8 021-1	100	00	3NE8 024-1	160	00	--	--
3RW30 38	72	--	--	--	3NE8 022-1	125	00	3NE8 024-1	160	00	--	--
3RW30 46	80	--	--	--	3NE8 022-1	125	00	3NE8 024-1	160	00	--	--
3RW30 47	106	--	--	--	3NE8 024-1	160	00	3NE8 024-1	160	00	--	--

Soft starters ToC 2 Q11 Type	Rated current A	Line contactors (optional)		Motor starter protectors		Line protection, maximum	
		Q21	Q1 Type	Rated current A	F1 Type	Rated current A	Size

Type of coordination "2" ¹⁾ : I _q = 65 kA at 480 V 10 %							
3RW30 03 ²⁾	3	3RT10 15	3RV10 11-1EA10	4	3NA3 805 ³⁾	20	000
3RW30 13	3.6	3RT10 15	3RV10 21-1FA10	5	3NA3 803-6	10	000
3RW30 14	6.5	3RT10 15	3RV10 21-1HA10	8	3NA3 805-6	16	000
3RW30 16	9	3RT10 16	3RV10 21-1JA10	10	3NA3 807-6	20	000
3RW30 17	12.5	3RT10 24	3RV10 21-1KA10	12.5	3NA3 810-6	25	000
3RW30 18	17.6	3RT10 26	3RV10 21-1BA10	20	3NA3 814-6	35	000
3RW30 26	25	3RT10 26	3RV10 31-4DA10	25	3NA3 822-6	63	00
3RW30 27	32	3RT10 34	3RV10 31-4EA10	32	3NA3 824-6	80	00
3RW30 28	38	3RT10 35	3RV10 31-4FA10	40	3NA3 824-6	80	00
3RW30 36	45	3RT10 36	3RV10 31-4GA10	45	3NA3 130-6	100	1
3RW30 37	63	3RT10 44	3RV10 41-4JA10	63	3NA3 132-6	125	1
3RW30 38	72	3RT10 45	3RV10 41-4KA10	75	3NA3 132-6	125	1
3RW30 46	80	3RT10 45	3RV10 41-4LA10	90	3NA3 136-6	160	1
3RW30 47	106	3RT10 46	3RV10 41-4MA10	100	3NA3 136-6	160	1

¹⁾ The types of coordination are explained under "3RA1 Fuseless Load Feeders". The type of coordination "2" refers only to soft starters in combination with the stipulated protective device (motor starter protector/circuit breaker/fuse), not to any additional components in the feeder.
²⁾ I_q = 50 kA at 400 V.
³⁾ 3NA3 805-1 (LV HRC00), 5SB2 61 (DIAZED).

Characteristic curves

Permissible installation height

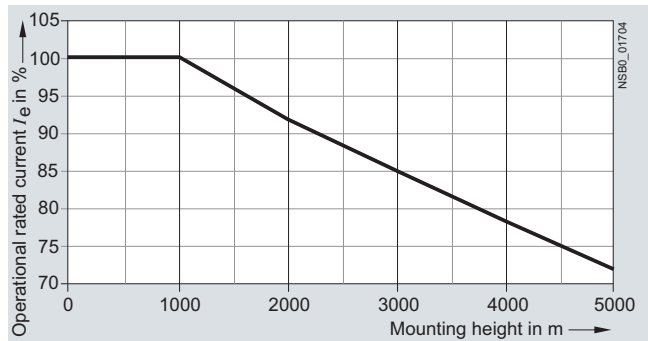

At an installation height above 2000 m, the max. permissible operational voltage is reduced to 460 V.

More information

Application examples for normal starting (Class 10)

Normal starting Class 10 (up to 20 s with 300 % $I_{n \text{ motor}}$).

The soft starter rating can be selected to be as high as the rating of the motor used

Application		Conveyor belt	Roller conveyor	Compressor	Small fan	Pump	Hydraulic pump
Starting parameters							
• Voltage ramp and current limiting							
- Starting voltage	%	70	60	50	40	40	40
- Starting time	s	10	10	20	20	10	10

Note:

These tables present sample set values and device sizes. They are intended only for the purposes of information and are not binding. The set values depend on the application in question and must be optimized during commissioning.

The soft starter dimensions should be checked where necessary with the Win-Soft Starter software or with the help of Technical Assistance.

For Operation in the Control Cabinet

3RW Soft Starters

3RW30 for standard applications

Configuration

The 3RW solid-state motor controllers are designed for easy starting conditions. In the event of deviating conditions or increased switching frequency, it may be necessary to choose a larger device. For accurate dimensioning, use the Win-Soft Starter selection and simulation program.

If necessary, an overload relay for heavy starting must be selected where long starting times are involved. PTC sensors are recommended.

In the motor feeder between the SIRIUS 3RW soft starter and the motor, no capacitive elements are permitted (e. g. no reactive-power compensation equipment). In addition, neither static systems for reactive-power compensation nor dynamic PFC (Power Factor Correction) must be operated in parallel during starting and ramp-down of the soft starter. This is important to prevent faults arising on the compensation equipment and/or the soft starter.

All elements of the main circuit (such as fuses, controls and overload relays) should be dimensioned for direct starting, following the local short-circuit conditions. Fuses, controls and overload relays must be ordered separately. Please observe the maximum switching frequencies specified in the technical specifications.

Note:

When induction motors are switched on, voltage drops occur as a rule on starters of all types (direct starters, wye-delta starters, soft starters). The infeed transformer must always be dimensioned such that the voltage dip when starting the motor remains within the permissible tolerance. If the infeed transformer is dimensioned with only a small margin, it is best for the control voltage to be supplied from a separate circuit (independently of the main voltage) in order to avoid the potential switching off of the soft starter.

Schematic circuit diagram

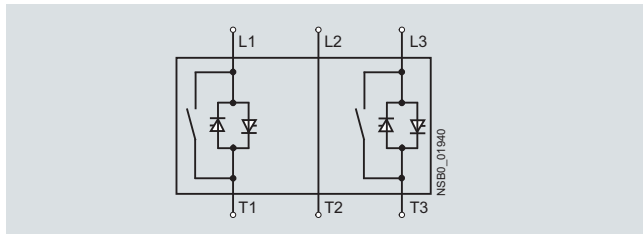

A bypass contact system is already integrated in the 3RW30 soft starter and therefore does not have to be ordered separately.

Status graphs

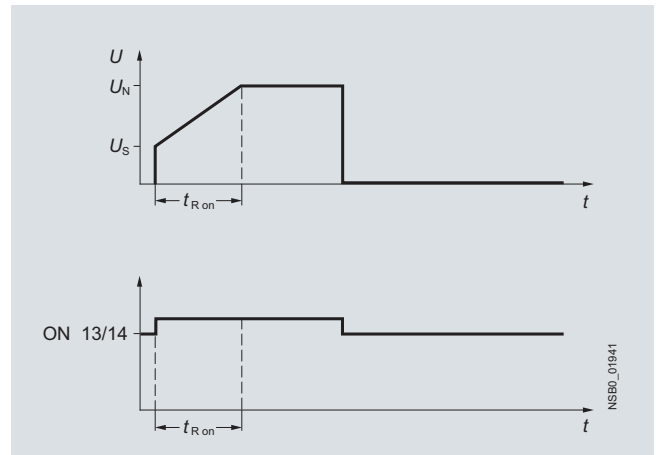

Win-Soft Starter selection and simulation program

With this software, you can simulate and select all Siemens soft starters, taking into account various parameters such as mains properties, motor and load data, and special application requirements.

The software is a valuable tool, which makes complicated, lengthy manual calculations for determining the required soft starters superfluous.

The Win-Soft Starter selection and simulation program can be downloaded from:

<http://www.siemens.com/softstarter> > Software

More information can be found on the Internet at:

<http://www.siemens.com/softstarter>

For Operation in the Control Cabinet

3RW Soft Starters

3RW40 for standard applications

Overview

SIRIUS 3RW40 soft starters have all the same advantages as the 3RW30 soft starters.

The SIRIUS 3RW40 soft starters are characterized above all by their small space requirements. Integrated bypass contacts mean that no power loss has to be taken into the bargain at the power semiconductors (thyristors) after the motor has started up. This cuts down on heat losses, enabling a more compact design and making external bypass circuits superfluous.

At the same time this soft starter comes with additional integrated functions such as adjustable current limiting, motor overload and intrinsic device protection, and optional thermistor motor protection. The higher the motor rating, the more important these functions because they make it unnecessary to purchase and install protection equipment such as overload relays.

Internal intrinsic device protection prevents the thermal overloading of the thyristors and the power section defects this can cause. As an option the thyristors can also be protected by semiconductor fuses from short-circuiting.

Thanks to integrated status monitoring and fault monitoring, this compact soft starter offers many different diagnostics options. Up to four LEDs and relay outputs permit differentiated monitoring and diagnostics of the operating mechanism by indicating the operating state as well as for example mains or phase failure, missing load, non-permissible tripping time/class setting, thermal overloading or device faults.

Soft starters rated up to 250 kW (at 400 V) for standard applications in three-phase networks are available. Extremely small sizes, low power losses and simple start-up are just three of the many advantages of the SIRIUS 3RW40 soft starters.

"Increased safety" type of protection EEx e according to ATEX directive 94/9/EC

The 3RW40 soft starter sizes S0 to S12 are suitable for the starting of explosion-proof motors with "increased safety" type of protection EEx e.

See "Appendix" -> "Standards and approvals" -> "Type overview of approved devices for potentially explosive areas (ATEX explosion protection)".

Function

The space required by the compact SIRIUS 3RW40 soft starter is often only about one third of that required by a contactor assembly for wye-delta starting of comparable rating. This not only saves space in the control cabinet and on the standard mounting rail but also does away completely with the wiring work needed for wye-delta starters. This is notable in particular for higher motor ratings which are only rarely available as fully wired solutions.

At the same time the number of cables from the starter to the motor is reduced from six to three. Compact dimensions, short start-up times, easy wiring and fast commissioning make themselves felt as clear-cut cost advantages.

The bypass contacts of these soft starters are protected during operation by an integrated solid-state arc quenching system. This prevents damage to the bypass contacts in the event of a fault, e. g. brief disconnection of the control voltage, mechanical shocks or life-related component defects on the coil operating mechanism or main contact spring.

The starting current of particularly powerful operating mechanisms can place an unjustifiable load on the local supply system. Soft starters reduce this starting current by means of their voltage ramp. Thanks to the adjustable current limiting, the SIRIUS 3RW40 soft starter takes even more pressure off the supply system. It leaves the set start ramp during the ramp-up – the ramp gradient is fixed by the starting voltage and the ramp time – as soon as the selected current limit is reached. From this moment the voltage of the soft starter is controlled so that the current supplied to the motor remains constant. This process is ended either by completion of the motor ramp-up or by tripping by the intrinsic device protection or the motor overload protection. As the result of this function the actual motor ramp-up can well take longer than the ramp time selected on the soft starter.

Thanks to the integrated motor overload protection according to IEC 60947-4-2 there is no need of an additional overload relay on the new soft starters. The rated motor current, the setting of the overload tripping time (Class times) and the reset of the motor overload protection function can be adjusted easily and quickly. Using a 4-step rotary potentiometer it is possible to set different overload tripping times on the soft starter. In addition to Class 10, 15 and 20 it is also possible to switch off the motor overload protection if a different motor management control device is to be used for this function, e. g. with connection to PROFIBUS.

Device versions with thermistor motor protection evaluation are available up to a rating of 55 kW (at 400 V). A "Thermoclick" measuring probe can be connected directly, as can a PTC of type A. Thermal overloading of the motor, open circuits and short-circuits in the sensor circuit all result in the direct disconnection of the soft starter. And if ever the soft starter trips, various reset options are available the same as with intrinsic device protection and motor load protection: manually with the reset button, automatically or remotely through brief disconnection of the control voltage.

The new series of devices comes with the "polarity balancing" control method, which is designed to prevent direct current components in two-phase controlled soft starters. On two-phase controlled soft starters the current resulting from superimposition of the two controlled phases flows in the uncontrolled phase. This results for physical reasons in an asymmetric distribution of the three phase currents during the motor ramp-up. This phenomenon cannot be influenced, but in most applications it is non-critical.

Controlling the power semiconductors results not only in this unbalance, however, but also in the previously mentioned direct current components which can cause severe noise generation on the motor at starting voltages of less than 50 %.

The control method used for these soft starters eliminates these direct current components during the ramp-up phase and prevents the braking torque which they can cause. It creates a motor ramp-up that is uniform in speed, torque and current rise, thus permitting a particularly gentle, two-phase starting of the motors. At the same time the acoustic quality of the starting operation comes close to the quality of a three-phase controlled soft starter. This is made possible by the on-going dynamic harmonizing and balancing of current half-waves of different polarity during the motor ramp-up. Hence the name "polarity balancing".

For Operation in the Control Cabinet

3RW Soft Starters

3RW40 for standard applications

As an option the thyristors can also be protected by SITOR semiconductor fuses from short-circuiting so that the soft starter is still functional after a short-circuit (type of coordination 2). Three LEDs are used to indicate the operating state as well as possible errors, e. g. non-permissible tripping time (CLASS setting), mains or phase failure, missing load, thermal overloading or device faults.

- Soft starting with voltage ramp; the starting voltage setting range U_s is 40 to 100 % and the ramp time t_R can be set from 0 to 20 s.
- Smooth ramp-down with voltage ramp; the running down time t_{off} can be set between 0 s to 20 s.
- Solid-state motor overload and intrinsic device protection
- Optional thermistor motor protection (up to size S3)
- Remote reset (integrated up to size S3, optional for size S6 and larger)
- Adjustable current limiting
- Integrated bypass contact system to minimize power loss
- Setting with potentiometers
- Simple mounting and commissioning
- Integrated status monitoring and fault monitoring
- Mains voltages 50/60 Hz, 200 to 600 V
- Various control voltage versions
 - Sizes S0 to S3: 24 V AC/DC and 110 to 230 V AC/DC
 - Sizes S6 to S12: 115 V AC and 230 V AC.
- Control by way of the internal 24 V DC supply and direct control by means of PLC are possible.
- Wide temperature range from -25 to +60 °C
- Built-in auxiliary contacts ensure user-friendly control and possible further processing within the system (for status graphs see page 31).

Technical specifications

Type	3RW40 2.		3RW40 3., 3RW40 4.			
Control electronics						
Rated values	Terminal					
Rated control supply voltage	A1/A2	V	24	110 ... 230	24	110 ... 230
• Tolerance		%	±20	-15/+10	±20	-15/+10
Rated control supply current						
• STANDBY		mA	< 150	< 50	< 200	< 50
• During pick-up		mA	< 200	< 100	< 5000	< 1500
• ON without fan		mA	< 250	< 50	< 200	< 50
• ON with fan		mA	< 300	< 70	< 250	< 70
Rated frequency		Hz	50/60			
• Tolerance		%	±10			
Control inputs						
IN			ON/OFF			
Rated operational current						
• AC		mA	Approx. 12	3/6	Approx. 12	3/6
• DC		mA	Approx. 12	1.5/3	Approx. 12	1.5/3
Relay outputs						
Output 1	ON/RUN mode ¹⁾	13/14	Operating indication (NO)			
Output 2	BYPASSED	23/24	Bypass indication (NO)			
Output 3	OVERLOAD/FAILURE	95/96/98	Overload/error indication (NC/NO)			
Rated operational current		A	3 AC-15/AC-14 at 230 V, 1 DC-13 at 24 V			
Protection against overvoltages		A	Protection by means of varistor through contact			
Short-circuit protection			4 A gL/gG operational class; 6 A quick (fuse is not included in scope of supply)			

¹⁾ Factory default: ON mode.

Type	3RW40 5.		3RW40 7.			
Control electronics						
Rated values	Terminal					
Rated control supply voltage	A1/A2	V AC	115	230	115	230
• Tolerance		%	-15/+10		-15/+10	
Rated control supply current STANDBY		mA	15		15	
Rated control supply current ON ¹⁾		mA	440	200	660	360
Rated frequency		Hz	50/60		50/60	
• Tolerance		%	±10		±10	
Control inputs						
IN			ON/OFF			
Rated operational current		mA	Approx. 10 acc. to DIN 19240			
Rated operational voltage		V DC	24 from internal supply dc+ or external DC supply (acc. to DIN 19240) through terminals and IN			
Relay outputs						
Output 1	ON/RUN mode ²⁾	13/14	Operating indication (NO)			
Output 2	BYPASSED	23/24	Bypass indication (NO)			
Output 3	OVERLOAD/FAILURE	95/96/98	Overload/error indication (NC/NO)			
Rated operational current		A	3 AC-15/AC-14 at 230 V, 1 DC-13 at 24 V			
Protection against overvoltages		A	Protection by means of varistor through contact			
Short-circuit protection			4 A gL/gG operational class; 6 A quick (fuse is not included in scope of supply)			

¹⁾ Values for the coil power consumption at +10 % U_n , 50 Hz.

²⁾ Factory default: ON mode.

For Operation in the Control Cabinet

3RW Soft Starters

3RW40 for standard applications

Type	3RW40 2., 3RW40 3., 3RW40 4.			
Control electronics				
Operating indications	LEDs	DEVICE	STATE/BYPASSED/FAILURE	OVERLOAD
Off		Green	Off	Off
Start		Green	Green flashing	Off
Bypass		Green	Green	Off
Ramp-down		Green	Green flashing	Off
Alarm signals				
I_e /Class setting not permissible		Green	Not relevant	Red flashing
Start inhibited/thyristors too hot		Yellow flashing	Not relevant	Off
Error signals				
• 24 V: $U < 0.75 \times U_s$ or $U > 1.25 \times U_s$		Off	Red	Off
• 110 ... 230 V: $U < 0.75 \times U_s$ or $U > 1.15 \times U_s$		Off	Red	Off
Non-permissible I_e /Class setting for edge 0 → 1 on input IN		Green	Red	Red flashing
Motor protection shut-down (overload thermistor)		Green	Off	Red
Thermistor defective (open circuit, short-circuit)		Green	Off	Red flickering
Thermal overloading of the thyristors		Yellow	Red	Off
Missing mains voltage, phase failure, missing load		Green	Red	Off
Device fault		Red	Red	Off
Type	3RW40 5. and 3RW40 7.			
Control electronics				
Operating indications	LEDs	DEVICE	STATE/BYPASSED FAILURE	OVERLOAD
Off		Green	Off	Off
Start		Green	Green flashing	Off
Bypass		Green	Green	Off
Ramp-down		Green	Green flashing	Off
Alarm signals				
I_e /Class setting not permissible		Green	Not relevant	Red flashing
Start inhibited/thyristors too hot		Yellow flashing	Not relevant	Off
Error signals				
$U < 0.75 \times U_s$ or $U > 1.15 \times U_s$		Off	Off	Red
Non-permissible I_e /Class setting for edge 0 → 1 on input IN		Green	Off	Red flashing
Motor protection shut-down		Green	Off	Red
Thermal overloading of the thyristors		Yellow	Off	Off
Missing mains voltage, phase failure, missing load		Green	Off	Off
Device fault		Red	Off	Off

For Operation in the Control Cabinet

3RW Soft Starters

3RW40 for standard applications

Type	3RW40 ..		Factory default
Protection functions			
Motor protection functions			
Trips in the event of		Thermal overloading of the motor	
Trip class to IEC 60947-4-1	Class	10/15/20	10
Phase failure sensitivity	%	> 40	
Overload warning		No	
Thermistor protection acc. to IEC 60947-8, type A/IEC 60947-5-1		Yes ¹⁾	
Reset option after tripping		Manual/automatic/remote reset ²⁾ (MAN/AUTO/REMOTE ²⁾)	
Recovery time	min	5	
Device protection functions			
Trips in the event of		Thermal overloading of the thyristors or bypass ³⁾	
Reset option after tripping		Manual/automatic/remote reset ²⁾ (MAN/AUTO/REMOTE ²⁾)	
Recovery time			
• During overloading of the thyristors	s	30	
• During overloading of the bypass	s	60	
Control times and parameters			
Control times			
Closing time (with connected control voltage)	ms	< 50	
Closing time (automatic/mains contactor mode)	ms	<300	
Recovery time (closing command in active ramp-down)	ms	100	
Mains failure bridging time			
Control supply voltage	ms	50	
Mains failure response time			
Load circuit	ms	500	
Reclosing lockout after overload trip			
Motor protection trip	min	5	
Device protection trip			
• During overloading of the thyristors	s	30	
• During overloading of the bypass	s	60	
Starting parameters			
Starting time	s	0 ... 20	7.5
Starting voltage	%	40 ... 100	40
Starting current limit		1.3 ... 5 x I _e	5 x I _e
Ramp-down parameters			
Ramp-down time	s	0 ... 20	0
Reset mode parameters (for motor/device protection shut-down)			
Manual reset	LEDs	Off	Off
Automatic reset	LEDs	Yellow	
Remote reset (REMOTE) ²⁾	LEDs	Green	
Start-up detection			
Yes			
Operating mode output 13/14			
Rising edge at	Start command		
Falling edge at	Off command	ON	ON
	Ramp-down end	RUN	

1) Optional up to size S3 (device variant).

2) Integrated remote reset (REMOTE) available only for 3RW40 2. to 3RW40 4.; remote reset with 3RU19 accessory module available for 3RW40 5. and 3RW40 7..

3) Bypass protection up to size S3.

For Operation in the Control Cabinet

3RW Soft Starters

3RW40 for standard applications

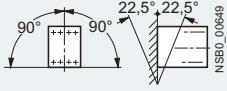
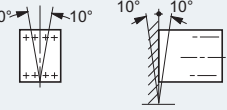
Type		3RW40 2.-..B.4, 3RW40 3.-..B.4, 3RW40 4.-..B.4	3RW40 2.-..B.5, 3RW40 3.-..B.5, 3RW40 4.-..B.5	3RW40 5.-.BB.4, 3RW40 7.-.BB.4	3RW40 5.-.BB.5, 3RW40 7.-.BB.5
Power electronics					
Rated operational voltage	V AC	200 ... 480	400 ... 600	200 ... 460	400 ... 600
Tolerance	%	-15/+10	-15/+10	-15/+10	-15/+10
Maximum blocking voltage (thyristor)	V AC	1600		1400	1800
Rated frequency	Hz	50/60			
Tolerance	%	±10			
Uninterrupted duty at 40 °C (% of I_e)	%	115			
Minimum load (% of minimum selectable rated motor current I_M)	%	20 (at least 2 A)			
Maximum cable length between soft starter and motor	m	300			
Permissible installation height	m	5000 (derating from 1000, see characteristic curves); higher on request			
Permissible mounting position					
<ul style="list-style-type: none"> With auxiliary fan (for 3RW40 2. ... 3RW40 4.) 					
<ul style="list-style-type: none"> Without auxiliary fan (for 3RW40 2. ... 3RW40 4.) 					
-- (fan integrated in the soft starter)					
Permissible ambient temperature					
Operation	°C	-25 ... +60; (derating from +40)			
Storage	°C	-40 ... +80			
Degree of protection					
				IP20 for 3RW40 2.;	IP00
				IP00 for 3RW40 3. and 3RW40 4.	

Type		3RW40 24	3RW40 26	3RW40 27	3RW40 28
Power electronics					
Load rating with rated operational current I_e					
• Acc. to IEC and UL/CSA ¹⁾ , for individual mounting, AC-53a					
- At 40 °C	A	12.5	25.3	32.2	38
- At 50 °C	A	11	23	29	34
- At 60 °C	A	10	21	26	31
Smallest adjustable rated motor current I_M					
For the motor overload protection					
A		5	10	17	23
Power loss					
• In operation after completed starting with uninterrupted rated operational current (40 °C) approx.					
W		2	8	13	19
• During starting with current limit set to 300 % I_M (40°C)					
W		17	47	55	64
Permissible rated motor current and starts per hour					
• For normal starting (Class 10)					
- Rated motor current $I_M^{(2)}$, starting time 3 s					
A		12.5	25	32	38
- Starts per hour ³⁾					
1/h		50	23	23	19
- Rated motor current $I_M^{(2)(4)}$, starting time 4 s					
A		12.5	25	32	38
- Starts per hour ³⁾					
1/h		36	15	16	12
• For heavy starting (Class 15)					
- Rated motor current $I_M^{(2)}$, starting time 4.5 s					
A		11	23	30	34
- Starts per hour ³⁾					
1/h		49	21	18	18
- Rated motor current $I_M^{(2)(4)}$, starting time 6 s					
A		11	23	30	34
- Starts per hour ³⁾					
1/h		36	14	13	13
• For heavy starting (Class 20)					
- Rated motor current $I_M^{(2)}$, starting time 6 s					
A		10	21	27	31
- Starts per hour ³⁾					
1/h		47	21	20	18
- Rated motor current $I_M^{(2)(4)}$, starting time 8 s					
A		10	21	27	31
- Starts per hour ³⁾					
1/h		34	15	14	13

¹⁾ Measurement at 60 °C according to UL/CSA not required.

²⁾ Current limit on soft starter set to 300 % I_M .

³⁾ For intermittent duty S4 with ON period = 30 %, $T_U = 40$ °C, stand-alone installation vertical. The quoted switching frequencies do not apply for automatic mode.

⁴⁾ Maximum adjustable rated motor current I_M , dependent on CLASS setting.

For Operation in the Control Cabinet

3RW Soft Starters

3RW40 for standard applications

Type		3RW40 36	3RW40 37	3RW40 38	3RW40 46	3RW40 47
Power electronics						
Load rating with rated operational current I_e						
• Acc. to IEC and UL/CSA ¹⁾ , for individual mounting, AC-53a						
- At 40 °C	A	45	63	72	80	106
- At 50 °C	A	42	58	62.1	73	98
- At 60 °C	A	39	53	60	66	90
Smallest adjustable rated motor current I_M						
For the motor overload protection						
	A	23	26	35	43	46
Power loss						
• In operation after completed starting with uninterrupted rated operational current (40 °C) approx.						
	W	6	12	15	12	21
• During starting with current limit set to 300 % I_M (40°C)						
	W	79	111	125	144	192
Permissible rated motor current and starts per hour						
• For normal starting (Class 10)						
- Rated motor current $I_M^{(2)}$, starting time 3 s						
	A	45	63	72	80	106
- Starts per hour ³⁾	1/h	38	23	22	22	15
- Rated motor current $I_M^{(2)4)}$, starting time 4 s						
	A	45	63	72	80	106
- Starts per hour ³⁾	1/h	26	15	15	15	10
• For heavy starting (Class 15)						
- Rated motor current $I_M^{(2)}$, starting time 4.5 s						
	A	42	50	56	70	84
- Starts per hour ³⁾	1/h	30	34	34	24	23
- Rated motor current $I_M^{(2)4)}$, starting time 6 s						
	A	42	50	56	70	84
- Starts per hour ³⁾	1/h	21	24	24	16	17
• For heavy starting (Class 20)						
- Rated motor current $I_M^{(2)}$, starting time 6 s						
	A	38	46	50	64	77
- Starts per hour ³⁾	1/h	30	31	34	23	23
- Rated motor current $I_M^{(2)4)}$, starting time 8 s						
	A	38	46	50	64	77
- Starts per hour ³⁾	1/h	21	22	24	16	16

1) Measurement at 60 °C according to UL/CSA not required.

2) Current limit on soft starter set to 300 % I_M .

3) For intermittent duty S4 with ON period = 30 %, $T_U = 40$ °C, stand-alone installation vertical. The quoted switching frequencies do not apply for automatic mode.

4) Maximum adjustable rated motor current I_M , dependent on CLASS setting.

Type		3RW40 55	3RW40 56	3RW40 73	3RW40 74	3RW40 75	3RW40 76
Power electronics							
Load rating with rated operational current I_e							
• Acc. to IEC and UL/CSA ¹⁾ , for individual mounting, AC-53a							
- At 40 °C	A	134	162	230	280	356	432
- At 50 °C	A	117	145	205	248	315	385
- At 60 °C	A	100	125	180	215	280	335
Smallest adjustable rated motor current I_M							
For the motor overload protection							
	A	59	87	80	130	131	207
Power loss							
• In operation after completed starting with uninterrupted rated operational current (40 °C) approx.							
	W	60	75	75	90	125	165
• During starting with current limit set to 350 % ²⁾ I_M (40°C)							
	W	1043	1355	2448	3257	3277	3600
Permissible rated motor current and starts per hour							
• For normal starting (Class 10)							
- Rated motor current $I_M^{(2)}$, starting time 10 s							
	A	134	162	230	280	356	432
- Starts per hour ³⁾	1/h	20	8	14	20	16	17
- Rated motor current $I_M^{(2)4)}$, starting time 20 s							
	A	134	162	230	280	356	432
- Starts per hour ³⁾	1/h	7	1.4	3	8	5	5
• For heavy starting (Class 15)							
- Rated motor current $I_M^{(2)}$, starting time 15 s							
	A	134	152	210	250	341	402
- Starts per hour ³⁾	1/h	11	8	11	13	11	12
- Rated motor current $I_M^{(2)4)}$, starting time 30 s							
	A	134	152	210	250	341	402
- Starts per hour ³⁾	1/h	1.2	1.7	1	6	2	2
• For heavy starting (Class 20)							
- Rated motor current $I_M^{(2)}$, starting time 20 s							
	A	124	142	200	230	311	372
- Starts per hour ³⁾	1/h	12	9	10	10	10	10
- Rated motor current $I_M^{(2)4)}$, starting time 40 s							
	A	124	142	200	230	311	372
- Starts per hour ³⁾	1/h	2	2	1	5	1	1

1) Measurement at 60 °C according to UL/CSA not required.

2) Current limit on soft starter set to 350 % I_M .



3) For intermittent duty S4 with ON period = 70 %, $T_U = 40$ °C, stand-alone installation vertical. The quoted switching frequencies do not apply for automatic mode.

4) Maximum adjustable rated motor current I_M , dependent on CLASS setting.

For Operation in the Control Cabinet

3RW Soft Starters







3RW40 for standard applications

Soft starters	Type		3RW40 2.	3RW40 3.	3RW40 4.	
Conductor cross-sections						
Screw terminals	Main conductors					
Front clamping point connected 	• Solid	mm ²	2 x (1.5 ... 2.5); 2 x (2.5 ... 6) acc. to IEC 60947; max. 1 x 10	2 x (1.5 ... 16)	2 x (2.5 ... 16)	
	• With end sleeve	mm ²	2 x (1.5 ... 2.5); 2 x (2.5 ... 6)	1 x (0.75 ... 25)	1 x (2.5 ... 35)	
	• Stranded	mm ²	--	1 x (0.75 ... 35)	1 x (4 ... 70)	
	• AWG cables					
	- Solid	AWG	2 x (16 ... 12)			
	- Solid or stranded	AWG	2 x (14 ... 10)	1 x (18 ... 2)	2 x (10 ... 1/0)	
	- Stranded	AWG	1 x 8	--	--	
	Rear clamping point connected 	• Solid	mm ²	--	2 x (1.5 ... 16)	2 x (2.5 ... 16)
		• With end sleeve	mm ²	--	1 x (1.5 ... 25)	1 x (2.5 ... 50)
		• Stranded	mm ²	--	1 x (1.5 ... 35)	1 x (10 ... 70)
• AWG cables						
Both clamping points connected 	- Solid or stranded	AWG	--	1 x (16 ... 2)	2 x (10 ... 1/0)	
	• Solid	mm ²	--	2 x (1.5 ... 16)	2 x (2.5 ... 16)	
	• With end sleeve	mm ²	--	2 x (1.5 ... 16)	2 x (2.5 ... 35)	
	• Stranded	mm ²	--	2 x (1.5 ... 25)	2 x (10 ... 50)	
	• AWG cables					
	- Solid or stranded	AWG	--	2 x (16 ... 2)	1 x (10 ... 2/0)	
	• Tightening torque	NM lb.in	2 ... 2.5 18 ... 22	4.5 40	6.5 58	
	Tools		PZ 2	PZ 2	Allen screw 4 mm	
	Degree of protection		IP20	IP20 (IP00 terminal compartment)	IP20 (IP00 terminal compartment)	
	Spring-type terminals	Main conductors				
	• Solid	mm ²	1 ... 10	--		
	• Finely stranded with end sleeve	mm ²	1 ... 6 end sleeves without plastic collar	--		
	• AWG cables					
	- Solid or stranded (finely stranded)	AWG	16 ... 10	--		
	- Stranded	AWG	1 x 8	--		
	Tools		DIN ISO 2380-1A0; 5 x 3	--		
	Degree of protection		IP20	--		
Busbar connections	Main conductors					
	• With cable lug acc. to DIN 46234 or max. 20 mm wide					
	- Stranded	mm ²	--		2 x (10 ... 70)	
	- Finely stranded	mm ²	--		2 x (10 ... 50)	
	• AWG cables, solid or stranded	AWG	--		2 x (7 ... 1/0)	

For Operation in the Control Cabinet

3RW Soft Starters

3RW40 for standard applications

Soft starters	Type		3RW40 5.	3RW40 7.
Conductor cross-sections				
Screw terminals	Main conductors			
With box terminal			3RT19 55-4G (55 kW)	3RT19 66-4G
Front clamping point connected	<ul style="list-style-type: none"> Finely stranded with end sleeve Finely stranded without end sleeve Stranded Ribbon cable conductors (number x width x thickness) AWG cables, solid or stranded 	mm ² mm ² mm ² mm AWG	16 ... 70 16 ... 70 16 ... 70 Min. 3 x 9 x 0.8 Max. 6 x 15.5 x 0.8 6 ... 2/0	70 ... 240 70 ... 240 95 ... 300 Min. 6 x 9 x 0.8 Max. 20 x 24 x 0.5 3/0 ... 600 kcmil
				
Rear clamping point connected	<ul style="list-style-type: none"> Finely stranded with end sleeve Finely stranded without end sleeve Stranded Ribbon cable conductors (number x width x thickness) AWG cables, solid or stranded 	mm ² mm ² mm ² mm AWG	16 ... 70 16 ... 70 16 ... 70 Min. 3 x 9 x 0.8 Max. 6 x 15.5 x 0.8 6 ... 2/0	120 ... 185 120 ... 185 120 ... 240 Min. 6 x 9 x 0.8 Max. 20 x 24 x 0.5 250 ... 500 kcmil
				
Both clamping points connected	<ul style="list-style-type: none"> Finely stranded with end sleeve Finely stranded without end sleeve Stranded Ribbon cable conductors (number x width x thickness) AWG cables, solid or stranded Terminal screws - Tightening torque 	mm ² mm ² mm ² mm AWG NM lb.in	Max. 1 x 50, 1 x 70 Max. 1 x 50, 1 x 70 Max. 2 x 70 Max. 2 x (6 x 15.5 x 0.8) Max. 2 x 1/0 M10 (hexagon socket, A/F4) 10 ... 12 90 ... 110	Min. 2 x 50; max. 2 x 185 Min. 2 x 50; max. 2 x 185 Max. 2 x 70; max. 2 x 240 Max. 2 x (20 x 24 x 0.5) Min. 2 x 2/0 Max. 2 x 500 kcmil M12 (hexagon socket, A/F5) 20 ... 22 180 ... 195
				
Screw terminals	Main conductors			
With box terminal			3RT19 56-4G	
Front or rear clamping point connected	<ul style="list-style-type: none"> Finely stranded with end sleeve Finely stranded without end sleeve Stranded Ribbon cable conductors (number x width x thickness) AWG cables, solid or stranded 	mm ² mm ² mm ² mm AWG	16 ... 120 16 ... 120 16 ... 120 Min. 3 x 9 x 0.8 Max. 6 x 15.5 x 0.8 6 ... 250 kcmil	
 				
Both clamping points connected	<ul style="list-style-type: none"> Finely stranded with end sleeve Finely stranded without end sleeve Stranded Ribbon cable conductors (number x width x thickness) AWG cables, solid or stranded 	mm ² mm ² mm ² mm AWG	Max. 1 x 95, 1 x 120 Max. 1 x 95, 1 x 120 Max. 2 x 120 Max. 2 x (10 x 15.5 x 0.8) Max. 2 x 3/0	
				
Screw terminals	Main conductors			
	<u>Without box terminal/busbar connection</u>			
	<ul style="list-style-type: none"> Finely stranded with cable lug Stranded with cable lug AWG cables, solid or stranded Connecting bar (max. width) Terminal screws - Tightening torque 	mm ² mm ² AWG mm NM lb.in	16 ... 95 ¹⁾ 25 ... 120 ¹⁾ 4 ... 250 kcmil 17 M8 x 25 (A/F13) 10 ... 14 89 ... 124	50 ... 240 ²⁾ 70 ... 240 ²⁾ 2/0 ... 500 kcmil 25 M10 x 30 (A/F17) 14 ... 24 124 ... 210

¹⁾ When connecting cable lugs to DIN 46235, use 3RT19 56-4EA1 terminal cover for conductor cross-sections from 95 mm² to ensure phase spacing.

²⁾ When connecting cable lugs to DIN 46234, the 3RT19 66-4EA1 terminal cover must be used for cond. cross-sections of 240 mm² and more as well as DIN 46235 for cond. cross-sections of 185 mm² and more to keep the phase clearance.

Soft starters	Type		3RW40 ..
Conductor cross-sections			
Auxiliary conductors (1 or 2 conductors can be connected):			
Screw terminals			
	<ul style="list-style-type: none"> Solid Finely stranded with end sleeve AWG cables - Solid or stranded - Finely stranded with end sleeve Terminal screws - Tightening torque 	mm ² mm ² AWG AWG NM lb.in	2 x (0.5 ... 2.5) 2 x (0.5 ... 1.5) 2 x (20 ... 14) 2 x (20 ... 16) 0.8 ... 1.2 7 ... 10.3
Spring-type terminals			
	<ul style="list-style-type: none"> Solid - 3RW40 2... 3RW40 4. - 3RW40 5., 3RW40 7. Finely stranded with end sleeve AWG cables, solid or stranded 	mm ² mm ² mm ² AWG	2 x (0.25 ... 2.5) 2 x (0.25 ... 1.5) 2 x (0.25 ... 1.5) 2 x (24 ... 14) for 3RW40 2... 3RW40 4.; 2 x (24 ... 16) for 3RW40 5. and 3RW40 7.

For Operation in the Control Cabinet

3RW Soft Starters

3RW40 for standard applications

	Standard	Parameters
Electromagnetic compatibility acc. to EN 60947-4-2		
<i>EMC interference immunity</i>		
Electrostatic discharge (ESD)	EN 61000-4-2	±4 kV contact discharge, ±8 kV air discharge
Electromagnetic RF fields	EN 61000-4-3	Frequency range: 80 ... 1000 MHz with 80 % at 1 kHz Degree of severity 3: 10 V/m
Conducted RF interference	EN 61000-4-6	Frequency range: 150 kHz ... 80 MHz with 80 % at 1 kHz Interference 10 V
RF voltages and RF currents on cables		
• Burst	EN 61000-4-4	±2 kV/5 kHz
• Surge	EN 61000-4-5	±1 kV line to line ±2 kV line to earth
<i>EMC interference emission</i>		
EMC interference field strength	EN 55011	Limit value of Class A at 30 ... 1000 MHz, limit value of Class B with 3RW40 2. 24 V AC/DC
Radio interference voltage	EN 55011	Limit value of Class A at 0.15 ... 30 MHz, limit value of Class B with 3RW40 2. 24 V AC/DC
<i>Radio interference suppression filters</i>		
Degree of noise suppression A (industrial applications)	Not required	
Degree of noise suppression B (applications for residential areas)		
Control voltage		
• 110 ... 230 V AC/DC	Not available ¹⁾	
• 115/230 V AC	Not available ¹⁾	
• 24 V AC/DC	Not required for 3RW40 2.; required for 3RW40 3. and 3RW40 4. (see table)	

¹⁾ Degree of noise suppression B cannot be obtained through the use of filters as the strength of the electromagnetic field is not attenuated by the filter.

Soft starter type	Rated current Soft starters A	Recommended filters ¹⁾		
		Voltage range 200 ... 480 V		
		Filter type	Rated current filters A	Terminals mm ²
3RW40 36	45	4EF1512-1AA10	50	16
3RW40 37	63	4EF1512-2AA10	66	25
3RW40 38	72	4EF1512-3AA10	90	25
3RW40 46	80	4EF1512-3AA10	90	25
3RW40 47	106	4EF1512-4AA10	120	50

¹⁾ The radio interference suppression filter is used to remove the conducted interference from the main circuit. The field-related emissions comply with degree of noise suppression B. Filter selection applies under standard conditions: 10 starts per hour, start time 4 s at 300 % I_e .

For Operation in the Control Cabinet

3RW Soft Starters

3RW40 for standard applications

Fuse assignment

The type of coordination to which the motor feeder with soft starter is mounted depends on the application-specific requirements. Normally, fuseless mounting (combination of motor

starter protector/circuit breaker and soft starter) is sufficient. If type of coordination "2" is to be fulfilled, semiconductor fuses must be fitted in the motor feeder.

Fuseless version

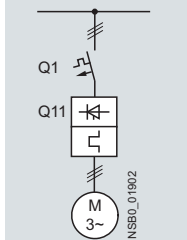

Soft starters ToC 1 Q11 Type	Rated current A	Motor starter protectors/circuit breakers ¹⁾			Rated current A	Rated current A	Rated current A	Rated current A
		400 V +10 % Q1 Type	400 V +10 % Q1 Type	$I_{q \max}$ kA				
Type of coordination "1"²⁾								
3RW40 24	12.5	3RV1 021-1KA10	3RV1 321-1KC10	55	16	--	--	--
3RW40 26	25	3RV1 021-4DA10	3RV1 321-4DC10	55	25	--	--	--
3RW40 27	32	3RV1 031-4EA10	3RV1 331-4EC10	55	32	--	--	--
3RW40 28	38	3RV1 031-4FA10	3RV1 331-4FC10	55	40	--	--	--
3RW40 36	45	3RV1 031-4GA10	3RV1 331-4GC10	20	45	--	--	--
3RW40 37	63	3RV1 041-4JA10	3RV1 341-4JC10	20	63	--	--	--
3RW40 38	72	3RV1 041-4KA10	3RV1 341-4KC10	20	75	--	--	--
3RW40 46	80	3RV1 041-4LA10	3RV1 341-4LC10	11	90	--	--	--
3RW40 47	106	3RV1 041-4MA10	3RV1 341-4MC10	11	100	--	--	--
3RW40 55	134	3VL3 720-2DC36		35	200	3VL3 720-1DC36	12	200
3RW40 56	162	3VL3 720-2DC36		35	200	3VL3 720-1DC36	12	200
3RW40 73	230	3VL4 731-2DC36		65	315	3VL5 731-3DC36	35	315
3RW40 74	280	3VL4 731-2DC36		65	315	3VL5 731-3DC36	35	315
3RW40 75	356	3VL4 740-2DC36		65	400	3VL5 740-3DC36	35	400
3RW40 76	432	3VL5 750-2DC36		65	500	3VL5 750-3DC36	35	500

1) The rated motor current must be considered when selecting the devices. The 3RV13 motor starter protectors are used for starter combinations (without motor protection). Motor protection is provided in this case by the 3RW40 soft starter.

2) The types of coordination are explained in more detail under "3RA1 Fuseless Load Feeders".

Fused version (line protection only)

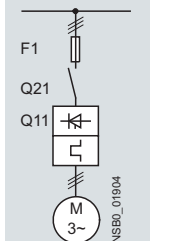

Soft starters ToC 1 Q11 Type	Rated current A	Line protection, maximum		Size	Line contactors (optional) Q21
		F1 Type	Rated current A		
Type of coordination "1"¹⁾: $I_q = 65 \text{ kA at } 600 \text{ V } +5 \%$					
3RW40 24	12.5	3NA3 820-6	50	00	3RT10 24
3RW40 26	25	3NA3 822-6	63	00	3RT10 26
3RW40 27	32	3NA3 824-6	80	00	3RT10 34
3RW40 28	38	3NA3 824-6	80	00	3RT10 35
3RW40 36	45	3NA3 130-6	100	1	3RT10 36
3RW40 37	63	3NA3 132-6	125	1	3RT10 44
3RW40 38	72	3NA3 132-6	125	1	3RT10 45
3RW40 46	80	3NA3 136-6	160	1	3RT10 45
3RW40 47	106	3NA3 136-6	160	1	3RT10 46
3RW40 55	134	3NA3 244-6	250	2	3RT10 55-6A.36
3RW40 56	162	3NA3 244-6	250	2	3RT10 56-6A.36
3RW40 73	230	2 x 3NA3 354-6	2 x 355	3	3RT10 65-6A.36
3RW40 74	280	2 x 3NA3 354-6	2 x 355	3	3RT10 66-6A.36
3RW40 75	356	2 x 3NA3 365-6	2 x 500	3	3RT10 75-6A.36
3RW40 76	432	2 x 3NA3 365-6	2 x 500	3	3RT10 76-6A.36

1) The types of coordination are explained under "3RA1 Fuseless Load Feeders". The type of coordination "1" refers only to soft starters in combination

with the stipulated protective device (motor starter protector/circuit breaker/fuse), not to any additional components in the feeder.

For Operation in the Control Cabinet

3RW Soft Starters

3RW40 for standard applications

Fused version with 3NE1 SITOR fuses (semiconductor and line protection)

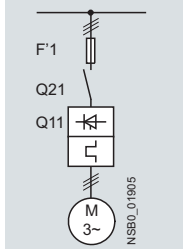

For matching fuse bases see Catalog LV 1 under "SENTRON Switching and Protection Devices for Power Distribution" → "Switch Disconnectors", and Catalog ET B1 under "BETA Protecting" → "SITOR Semiconductor Fuses" or go to www.siemens.com/sitor → "Products" → "BETA Protecting" → "SITOR"

Soft starters ToC 2	Rated current	All-range fuses			Line contactors	
		F1 Type	Rated current A	Size	(optional) Q21	
Q11 Type	A	F1 Type	A		Q21	
Type of coordination "2"¹⁾: $I_q = 65 \text{ kA at } 600 \text{ V } +5 \%$						
3RW40 24	12.5	3NE1 814-0	20	000	3RT10 24	
3RW40 26	25	3NE1 803-0	35	000	3RT10 26	
3RW40 27	32	3NE1 020-2	80	00	3RT10 34	
3RW40 28	38	3NE1 020-2	80	00	3RT10 35	
3RW40 36	45	3NE1 020-2	80	00	3RT10 36	
3RW40 37	63	3NE1 820-0	80	000	3RT10 44	
3RW40 38	72	3NE1 820-0	80	000	3RT10 45	
3RW40 46	80	3NE1 021-0	100	00	3RT10 45	
3RW40 47	106	3NE1 022-0	125	00	3RT10 46	
3RW40 55	134	3NE1 227-2	250	1	3RT10 55-6A.36	
3RW40 56	162	3NE1 227-2	250	1	3RT10 56-6A.36	
3RW40 73	230	3NE1 331-2	350	2	3RT10 65-6A.36	
3RW40 74	280	3NE1 333-2	450	2	3RT10 66-6A.36	
3RW40 75	356	3NE1 334-2	500	2	3RT10 75-6A.36	
3RW40 76	432	3NE1 435-2	560	3	3RT10 76-6A.36	

¹⁾ The types of coordination are explained in more detail under "3RA1 Fuseless Load Feeders".
The type of coordination "2" refers only to soft starters in combination with the stipulated protective device (circuit breaker/fuse), not to any additional components in the feeder.

ToC 1 Type of coordination "1"

ToC 2 Type of coordination "2"

The types of coordination are explained in more detail under "3RA1 Fuseless Load Feeders".

These types of coordination are indicated in the Technical specifications by orange backgrounds.

For Operation in the Control Cabinet

3RW Soft Starters

3RW40 for standard applications

Fused version with 3NE3 SITOR fuses (semiconductor protection by fuse, line and overload protection by motor starter protector; alternatively, installation with contactor and overload relay possible)

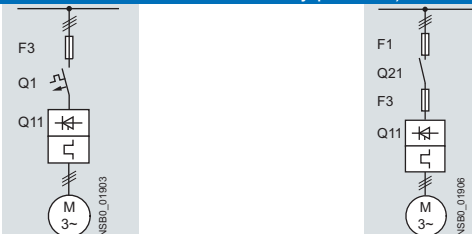

For matching fuse bases see Catalog LV 1 under "SENTRON Switching and Protection Devices for Power Distribution" → "Switch Disconnectors", and Catalog ET B1 under "BETA Protecting" → "SITOR Semiconductor Fuses" or go to www.siemens.com/sitor → "Products" → "BETA Protecting" → "SITOR"

Soft starters Toc 2 Q11 Type	Rated current A	Semiconductor fuses, minimum			Semiconductor fuses, maximum			Semiconductor fuses, minimum		
		F3 Type	Rated current A	Size	F3 Type	Rated current A	Size	F3 Type	Rated current A	Size
Type of coordination "2"¹⁾: I_q = 65 kA at 600 V +5 %										
3RW40 24	12.5	--	--	--	--	--	--	3NE4 101	32	0
3RW40 26	25	--	--	--	3NE3 221	100	1	3NE4 102	40	0
3RW40 27	32	--	--	--	3NE3 224	160	1	3NE4 118	63	0
3RW40 28	38	--	--	--	3NE3 224	160	1	3NE4 118	63	0
3RW40 36	45	--	--	--	3NE3 224	160	1	3NE4 120	80	0
3RW40 37	63	--	--	--	3NE3 225	200	1	3NE4 121	100	0
3RW40 38	72	3NE3 221	100	1	3NE3 227	250	1	--	--	--
3RW40 46	80	3NE3 222	125	1	3NE3 225	200	1	--	--	--
3RW40 47	106	3NE3 224	160	1	3NE3 231	350	1	--	--	--
3RW40 55	134	3NE3 227	250	1	3NE3 335	560	2	--	--	--
3RW40 56	162	3NE3 227	250	1	3NE3 335	560	2	--	--	--
3RW40 73	230	3NE3 232-0B	400	1	3NE3 333	450	2	--	--	--
3RW40 74	280	3NE3 233	450	1	3NE3 336	630	2	--	--	--
3RW40 75	356	3NE3 335	560	2	3NE3 336	630	2	--	--	--
3RW40 76	432	3NE3 337-8	710	2	3NE3 340-8	900	2	--	--	--

Soft starters Toc 2 Q11 Type	Rated current A	Semiconductor fuses max.			Semiconductor fuses min.			Semiconductor fuses max.			Cylindrical fuses	
		F3 Type	Rated current A	Size	F3 Type	Rated current A	Size	F3 Type	Rated current A	Size	F3 Type	Rated current A
Type of coordination "2"¹⁾: I_q = 65 kA at 600 V +5 %												
3RW40 24	12.5	3NE4 117	50	0	3NE8 015-1	25	00	3NE8 017-1	50	00	3NC2 240	40
3RW40 26	25	3NE4 117	50	0	3NE8 017-1	50	00	3NE8 021-1	100	00	3NC2 263	63
3RW40 27	32	3NE4 118	63	0	3NE8 018-1	63	00	3NE8 022-1	125	00	3NC2 280	80
3RW40 28	38	3NE4 118	63	0	3NE8 020-1	80	00	3NE8 024-1	160	00	3NC2 280	80
3RW40 36	45	3NE4 120	80	0	3NE8 020-1	80	00	3NE8 024-1	160	00	3NC2 280	80
3RW40 37	63	3NE4 121	100	0	3NE8 021-1	100	00	3NE8 024-1	160	00	--	--
3RW40 38	72	--	--	--	3NE8 022-1	125	00	3NE8 024-1	160	00	--	--
3RW40 46	80	--	--	--	3NE8 022-1	125	00	3NE8 024-1	160	00	--	--
3RW40 47	106	--	--	--	3NE8 024-1	160	00	3NE8 024-1	160	00	--	--
3RW40 55	134	--	--	--	--	--	--	--	--	--	--	--
3RW40 56	162	--	--	--	--	--	--	--	--	--	--	--
3RW40 73	230	--	--	--	--	--	--	--	--	--	--	--
3RW40 74	280	--	--	--	--	--	--	--	--	--	--	--
3RW40 75	356	--	--	--	--	--	--	--	--	--	--	--
3RW40 76	432	--	--	--	--	--	--	--	--	--	--	--

Soft starters Toc 2 Q11 Type	Rated current A	Line contactors (optional)		Motor starter protectors/circuit breakers			Line protection, maximum		
		Q21	Q1 Type	Rated current A	Rated current 575 V +10 % Q1 Type	Rated current A	Rated current A	Size	
Type of coordination "2"¹⁾: I_q = 65 kA at 600 V +5 %									
3RW40 24	12.5	3RT10 24	3RV1 021-4KA10	55	--	--	3NA3 820-6	50	00
3RW40 26	25	3RT10 26	3RV1 021-4DA10	55	--	--	3NA3 822-6	63	00
3RW40 27	32	3RT10 34	3RV1 031-4EA10	55	--	--	3NA3 824-6	80	00
3RW40 28	38	3RT10 35	3RV1 031-4FA10	55	--	--	3NA3 824-6	80	00
3RW40 36	45	3RT10 36	3RV1 031-4GA10	20	--	--	3NA3 130-6	100	1
3RW40 37	63	3RT10 44	3RV1 041-4JA10	20	--	--	3NA3 132-6	125	1
3RW40 38	72	3RT10 45	3RV1 041-4KA10	20	--	--	3NA3 132-6	125	1
3RW40 46	80	3RT10 45	3RV1 041-4LA10	11	--	--	3NA3 136-6	160	1
3RW40 47	106	3RT10 46	3RV1 041-4MA10	11	--	--	3NA3 136-6	160	1
3RW40 55	134	3RT10 55-6A.36	3VL3 720	200	3VL3 720	200	3NA3 244-6	250	2
3RW40 56	162	3RT10 56-6A.36	3VL3 720	200	3VL3 720	200	3NA3 244-6	250	2
3RW40 73	230	3RT10 65-6A.36	3VL4 731	315	3VL5 731	315	2 x 3NA3 354-6	2 x 355	3
3RW40 74	280	3RT10 66-6A.36	3VL4 731	315	3VL5 731	315	2 x 3NA3 354-6	2 x 355	3
3RW40 75	356	3RT10 75-6A.36	3VL4 740	400	3VL5 740	400	2 x 3NA3 365-6	2 x 500	3
3RW40 76	432	3RT10 76-6A.36	3VL5 750	500	3VL5 750	500	2 x 3NA3 365-6	2 x 500	3

¹⁾ The types of coordination are explained under "3RA1 Fuseless Load Feeders". The type of coordination "2" refers only to soft starters in combination

with the stipulated protective device (motor starter protector/circuit breaker/fuse), not to any additional components in the feeder.

Characteristic curves

Motor protection tripping characteristics for 3RW40 (with symmetry)

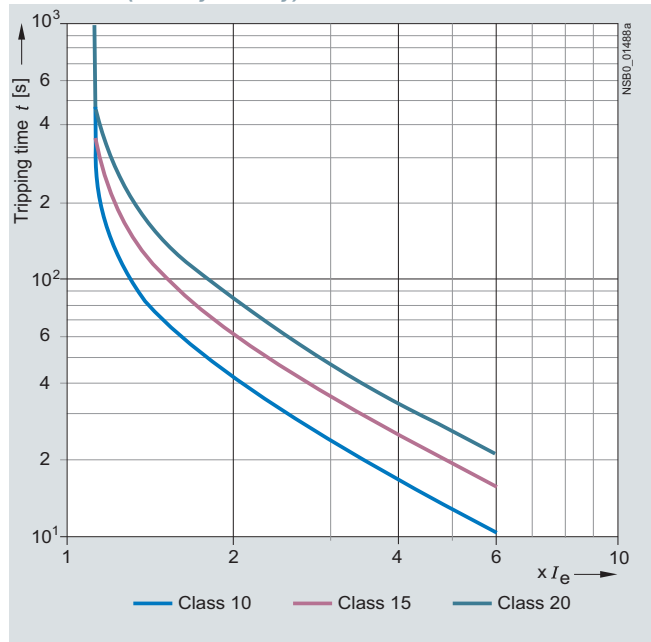

Motor protection tripping characteristics for 3RW40 (with asymmetry)

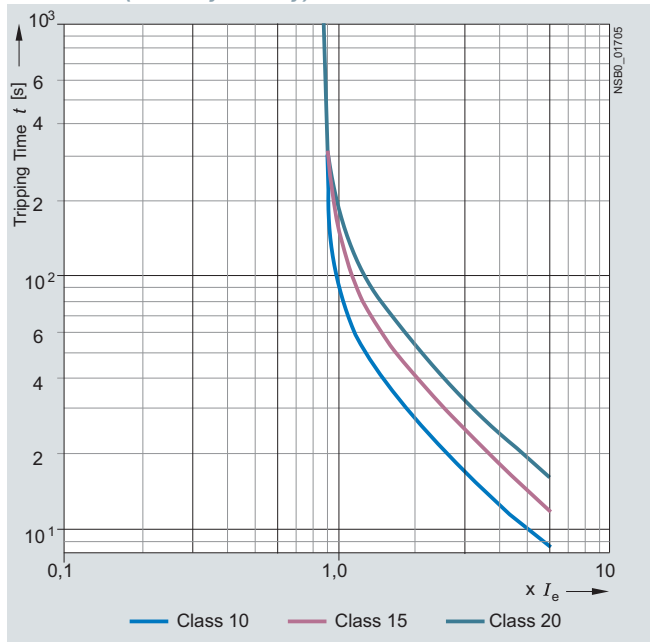

Permissible installation height

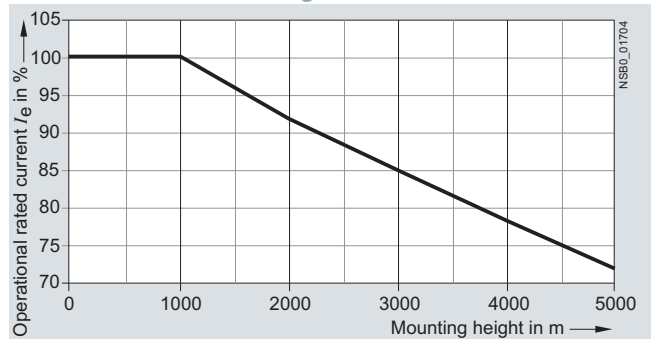

At an installation height above 2000 m, the max. permissible operational voltage is reduced to 460 V.

For Operation in the Control Cabinet

3RW Soft Starters

3RW40 for standard applications

More information

Application examples for normal starting (Class 10)

Normal starting Class 10 (up to 20 s with 350 % $I_{n, motor}$).

The soft starter rating can be selected to be as high as the rating of the motor used.

Application		Conveyor belt	Roller conveyor	Compressor	Small fan	Pump	Hydraulic pump
Starting parameters							
• Voltage ramp and current limiting							
- Starting voltage	%	70	60	50	40	40	40
- Starting time	s	10	10	10	10	10	10
- Current limit value		$5 \times I_M$	$5 \times I_M$	$4 \times I_M$	$4 \times I_M$	$4 \times I_M$	$4 \times I_M$
Ramp-down time	s	5	5	0	0	10	0

Application examples for heavy starting (Class 20)

Heavy starting Class 20 (up to 40 s with 350 % $I_{n, motor}$).

The soft starter has to be selected at least one performance class higher than the motor used.

Application		Stirrer	Centrifuge
Starting parameters			
• Voltage ramp and current limiting			
- Starting voltage	%	40	40
- Starting time	s	20	20
- Current limit value		$4 \times I_M$	$4 \times I_M$
Ramp-down time		0	0

Note:

These tables present sample set values and device sizes. They are intended only for the purposes of information and are not binding. The set values depend on the application in question and must be optimized during commissioning.

The soft starter dimensions should be checked where necessary with the Win-Soft Starter software or with the help of Technical Assistance.

For Operation in the Control Cabinet

3RW Soft Starters

3RW40 for standard applications

Configuration

The 3RW solid-state soft starters are designed for easy starting conditions. In the event of deviating conditions or increased switching frequency, it may be necessary to choose a larger device. For accurate dimensioning, use the Win-Soft Starter selection and simulation program.

Where long starting times are involved, the integrated solid-state overload relay for heavy starting should not be disconnected. PTC sensors are recommended. This also applies for the smooth ramp-down because during the ramp-down time an additional current loading applies in contrast to free ramp-down.

In the case of high switching frequencies in S4 mode, Siemens recommends the use of PTC sensors. For corresponding device versions with integrated thermistor motor protection or separate thermistor evaluation devices see Catalog LV 1.

In the motor feeder between the SIRIUS 3RW soft starter and the motor, no capacitive elements are permitted (e. g. no reactive-power compensation equipment). In addition, neither static systems for reactive-power compensation nor dynamic PFC (Power Factor Correction) must be operated in parallel during starting and ramp-down of the soft starter. This is important to prevent faults arising on the compensation equipment and/or the soft starter.

All elements of the main circuit (such as fuses and controls) should be dimensioned for direct starting, following the local short-circuit conditions. Fuses, controls and overload relays must be ordered separately. Please observe the maximum switching frequencies specified in the technical specifications.

Note:

When induction motors are switched on, voltage drops occur as a rule on starters of all types (direct starters, wye-delta starters, soft starters). The infeed transformer must always be dimensioned such that the voltage dip when starting the motor remains within the permissible tolerance. If the infeed transformer is dimensioned with only a small margin, it is best for the control voltage to be supplied from a separate circuit (independently of the main voltage) in order to avoid the potential switching off of the soft starter.

Schematic circuit diagram

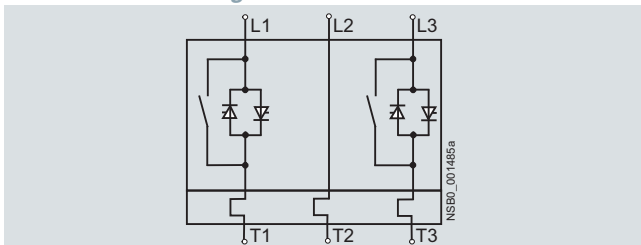

A bypass contact system and solid-state overload relay are already integrated in the 3RW40 soft starter and therefore do not have to be ordered separately.

Status graphs

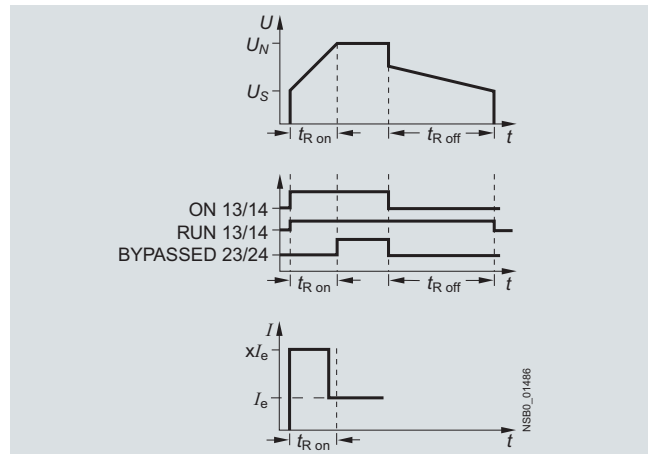

Win-Soft Starter selection and simulation program

With this software, you can simulate and select all Siemens soft starters, taking into account various parameters such as mains properties, motor and load data, and special application requirements.

The software is a valuable tool, which makes complicated, lengthy manual calculations for determining the required soft starters superfluous.

The Win-Soft Starter selection and simulation program can be downloaded from:

<http://www.siemens.com/softstarter> > Software

More information can be found on the Internet at:

<http://www.siemens.com/softstarter>

For Operation in the Control Cabinet

3RW Soft Starters

3RW44 for high-feature applications

Overview

In addition to soft starting and soft ramp-down, the solid-state SIRIUS 3RW44 soft starters provide numerous functions for higher-level requirements. They cover a performance range up to 710 kW (at 400 V) in the inline circuit and up to 1200 kW (at 400 V) in the inside-delta circuit.

The SIRIUS 3RW44 soft starters are characterized by a compact design for space-saving and clearly arranged control cabinet layouts. For optimized motor starting and stopping the innovative SIRIUS 3RW44 soft starters are an attractive alternative with considerable savings potential compared to applications with a frequency converter. The new torque control and adjustable current limiting enable the High-Feature soft starters to be used in nearly every conceivable task. They guarantee the reliable avoidance of sudden torque applications and current peaks during motor starting and stopping. This creates savings potential when calculating the size of the switchgear and when servicing the machinery installed. Be it for inline circuits or inside-delta circuits – the SIRIUS 3RW44 soft starter offers savings especially in terms of size and equipment costs.

The bypass contacts already integrated in the soft starter bypass the thyristors after a motor ramp-up is detected. This results in a further great reduction in the heat loss occurring during operation of the soft starter at rated value.

Combinations of various starting, operating and ramp-down possibilities ensure an optimum adaptation to the application-specific requirements. Operation and commissioning can be performed with the menu-controlled keypad and a menu-prompted, multi-line graphic display with background lighting. The optimized motor ramp-up and ramp-down can be effected quickly, easily and reliably by means of just a few settings with a previously selected language. Four-key operation and plain-text displays for each menu point guarantee full clarity at every moment of the parameterization and operation.

Applicable standards

- IEC 60947-4-2
- UL/CSA

Soft Starter ES parameterization software

Soft Starter ES software is used for the parameterization, monitoring and service diagnostics of SIRIUS 3RW44 High Feature soft starters.

See Catalog LV 1, Chapter 12 "Planning and Configuration with SIRIUS".

Function

Equipped with modern, ergonomic user prompting the SIRIUS 3RW44 soft starters can be commissioned quickly and easily using a keypad and a menu-prompted, multi-line graphic display with background lighting. The optimized motor ramp-up and ramp-down can be effected quickly, easily and reliably by means of just a few settings with a selectable language. Four-key operation and plain-text displays for each menu point guarantee full clarity at every moment of the parameterization and operation. During operation and when control voltage is applied, the display field continuously presents measured values and operating values as well as warnings and fault messages. An external display and operator module can be connected by means of a connection cable to the soft starter, thus enabling active indications and the like to be read directly from the control cabinet door.

The SIRIUS 3RW44 soft starters are equipped with optimum functionality. An integral bypass contact system reduces the power loss of the soft starter during operation. This reliably prevents heating of the switchgear environment. The SIRIUS 3RW44 soft starters have internal intrinsic device protection. This prevents thermal overloading of the power section's thyristors, e. g. due to unacceptably high closing operations.

Wiring outlay for installing an additional motor overload relay is no longer needed as the SIRIUS 3RW44 soft starters perform this function too. In addition they offer adjustable trip classes and a thermistor motor protection function. As an option the thyristors can also be protected by SITOR semiconductor fuses from short-circuiting so that the soft starter is still functional after a short-circuit (type of coordination 2). And even inrush current peaks are reliably avoided thanks to adjustable current limiting.

As a further option the SIRIUS 3RW44 soft starters can be upgraded with a PROFIBUS DP module. Thanks to their communication capability and their programmable control inputs and relay outputs the SIRIUS 3RW44 soft starters can be very easily and quickly integrated in higher-level controllers.

In addition a creep speed function is available for positioning and setting jobs. With this function the motor can be controlled in both directions of rotation with reduced torque and an adjustable, low speed.

On the other hand the SIRIUS 3RW44 soft starters offer a new, combined DC braking function for the fast stopping of driving loads.

Highlights

- Soft starting with breakaway pulse, torque control or voltage ramp, adjustable torque or current limiting as well as any combination of these, depending on load type
- Integrated bypass contact system to minimize power loss
- Various setting options for the starting parameters such as starting torque, starting voltage, ramp-up and ramp-down time, and much more in three separate parameter sets
- Start-up detection
- Inside-delta circuit for savings in terms of size and equipment costs
- Various ramp-down modes selectable: free ramp-down, torque-controlled pump ramp-down, combined DC braking
- Solid-state motor overload and intrinsic device protection
- Thermistor motor protection
- Keypad with a menu-prompted, multi-line graphic display with background lighting
- Interface for communication with the PC for more accurate setting of the parameters as well as for control and monitoring
- Simple adaptation to the motor feeder
- Simple mounting and commissioning
- Display of operating states and fault messages
- Connection to PROFIBUS with optional PROFIBUS DP module
- External display and operator module
- Mains voltages from 200 to 690 V, 50 to 60 Hz
- Applicable up to 60 °C (derating from 40 °C)

For Operation in the Control Cabinet

3RW Soft Starters

3RW44 for high-feature applications
Technical specifications

Type	Terminal		3RW44 ...-BC3.	3RW44 ...-BC4.
Control electronics				
Rated values				
Rated control supply voltage	A1/A2/PE	V	115 AC	230 AC
• Tolerance		%	-15/+10	-15/+10
Rated control supply current STANDBY		mA	30	20
Rated control supply current ON				
• 3RW44 2.		mA	300	170
• 3RW44 3.		mA	500	250
• 3RW44 4.		mA	750	400
• 3RW44 5.		mA	450	200
• 3RW44 6.		mA	650	300
Maximum current (pickup bypass)				
• 3RW44 2.		mA	1000	500
• 3RW44 3.		mA	2500	1250
• 3RW44 4.		mA	6000	3000
• 3RW44 5.		mA	4500	2500
• 3RW44 6.		mA	4500	2500
Rated frequency		Hz	50 ... 60	50 ... 60
• Tolerance		%	±10	±10

Type	Terminal		3RW44..	Factory default
Control electronics				
Control inputs				
Input 1	IN1			Start motor right parameter set 1
Input 2	IN2			No action
Input 3	IN3			No action
Input 4	IN4			Trip reset
Supply	L+/L-			
• Rated operational current	L+	mA	Approx. 10 per input to DIN 19240	
• Rated operational voltage	L-		Internal voltage: 24 V DC from internal supply through terminal L+ to IN1 ... IN4. Maximum load at L+ approx. 55 mA	
			External voltage: DC external voltage (acc. to DIN 19240) through terminals L- and IN1 ... IN4 (min. 12 V DC, max. 30 V DC)	
Thermistor motor protection input				
Input	T1/T2		PTC type A or Thermoclick	Deactivated
Relay outputs (floating auxiliary contacts)				
Output 1	13/14			ON period
Output 2	23/24			No action
Output 3	33/34			No action
Output 4	95/96/98			Group fault
Switching capacity of the relay outputs (auxiliary contacts)				
230 V/AC-15		A	3 at 240 V	
24 V/DC-13		A	1 at 24 V	
Protection against overvoltages			Protection by means of varistor through relay contact	
Short-circuit protection			4 A gL/gG operational class; 6 A quick (fuse is not included in scope of supply)	
Protection functions				
Motor protection functions				
Trips in the event of			Thermal overloading of the motor	
Trip class acc. to IEC 60947-4-1		Class	5/10/15/20/30	10
Phase failure sensitivity		%	>40	
Overload warning			Yes	
Reset and recovery			Manual/Automatic	Manual
Reset option after tripping			Manual/Automatic	Manual
Recovery time		min.	1 ... 30	1
Device protection functions				
Trips in the event of			Thermal overloading of the thyristors	
Reset option after tripping			Manual/Automatic	Manual
Recovery time		min.	0.5	
Bypass protection functions				
Trips in the event of			Thermal overloading of the bypass contacts	
Reset option after tripping			Manual	
Recovery time		min.	1	

For Operation in the Control Cabinet

3RW Soft Starters

3RW44 for high-feature applications

Type	3RW44..		Factory default
Control times and parameters			
Control times			
Closing time (with connected control voltage)	ms	<50	
Closing time (automatic mode)	ms	<4000	
Recovery time (closing command in active ramp-down)	ms	<100	
Mains failure bridging time			
Control supply voltage	ms	100	
Mains failure response time			
Load circuit	ms	100	
Reclosing lockout after overload trip			
Motor protection trip	min.	1 ... 30	1
Device protection trip	s	30	
Setting options for starting			
Voltage ramp for starting voltage	%	20 ... 100	30
Torque control for starting torque	%	10 ... 100	10
Torque control for limit torque	%	20 ... 200	150
Starting time	s	0 ... 360	20
Maximum starting time	s	1 ... 1000	Deactivated
Current limit value	%	125 ... 550 ¹⁾	450
Breakaway voltage	%	40 ... 100	80
Breakaway time	s	0 ... 2	Deactivated
Motor heat output	%	1 ... 100	20
Creep mode Left/Right running			
Speed factor as function of rated speed ($n = n_{rated}/\text{factor}$)		3 ... 21	7
Creep torque ²⁾	%	20 ... 100	50
Setting options for ramp-down			
Torque control for stopping torque	%	10 ... 100	10
Ramp-down time	s	0 ... 360	10
Dynamic braking torque	%	20 ... 100	50
DC braking torque	%	20 ... 100	50
Operating indications			
		Test voltage	
		Test mains phases	
		Ready to start	
		Start active	
		Motor running	
		Ramp-down active	
		Emergency start active	
Warnings/error signals			
		Mains voltage missing	
		Leading-edge phase error	
		Phase failure	
		• L1	
		• L2	
		• L3	
		Missing load phase	
		• T1	
		• T2	
		• T3	
		Failure	
		• Contact element 1 (thyristor)	
		• Contact element 2 (thyristor)	
		• Contact element 3 (thyristor)	
		Flash memory faulty	
		Supply voltage	
		• Below 75 %	
		• Below 85 %	
		• Over 110 %	
		Current unbalance exceeded	
		Thermal motor model overload	
		Prewarning limit exceeded	
		• Motor heating	
		• Time-related trip reserve	
		Bypass element defective	
		Mains voltage too high	
		Device not named	
		Wrong naming version	
		Current measuring range exceeded	
		Bypass element protection disconnection	
		Power section	
		• Overheated	
		• Overheating	

¹⁾ Max. current limit value for 3RW44 53 ... 3RW44 57: 500 % and for 3RW44 58 ... 3RW44 66: 450 %.

²⁾ Reference variable depends on the motor used but is always smaller than the rated torque of the motor.

For Operation in the Control Cabinet

3RW Soft Starters

3RW44 for high-feature applications

Type	3RW44 ..	Factory default
Control times and parameters		
Warnings/error signals (continued)		
	<ul style="list-style-type: none"> Temperature sensor <ul style="list-style-type: none"> • Overload • Open circuit • Short-circuit Ground fault <ul style="list-style-type: none"> • Detected Connection abort in manual operating mode Max. number of starts exceeded I_e limit value overshoot/undershoot Heat sink sensor <ul style="list-style-type: none"> • Open circuit • Short-circuit Quick-stop active Switching block defective I_e/class setting not permissible No external start-up parameters received PAA fault 	
Control inputs		
Input 1		Motor right parameter set 1
Input 2		No action
Input 3		No action
Input 4		Trip reset
Parameterizing options for control inputs 1 ... 4	<ul style="list-style-type: none"> No action Local manual mode Emergency start Creep speed Quick-stop Trip reset Motor right parameter set 1 Motor left parameter set 1¹⁾ Motor right parameter set 2 Motor left parameter set 2¹⁾ Motor right parameter set 3 Motor left parameter set 3¹⁾ 	
Relay outputs		
Output 1		ON period
Output 2		No action
Output 3		No action
Output 4		Group fault
Parameterizing options for relay outputs 1 ... 3	<ul style="list-style-type: none"> No action PAA output 1 PAA output 2 Input 1 Input 2 Input 3 Input 4 Starting Operation/Bypass Ramp-down ON period Command motor on DC braking contactor Group warning Group fault Bus fault Device fault Power on Ready to start 	
Motor temperature sensor		
	<ul style="list-style-type: none"> Deactivated Thermoclick PTC type A 	

¹⁾ Parameter motor left possible only in conjunction with creep mode.

For Operation in the Control Cabinet

3RW Soft Starters

3RW44 for high-feature applications

Type		3RW44 ...BC.4	3RW44 ...BC.5	3RW44 ...BC.6
Power electronics				
Rated operational voltage for inline circuit	V AC	200 ... 460	400 ... 600	400 ... 690
Tolerance	%	-15/+10	-15/+10	-15/+10
Maximum blocking voltage (thyristor)	V AC	1400	1800	1800
Rated operational voltage for inside-delta circuit	V AC	200 ... 460	400 ... 600	400 ... 600
Tolerance	%	-15/+10	-15/+10	-15/+10
Rated frequency	Hz	50 ... 60		
Tolerance	%	±10		
Uninterrupted duty at 40 °C (% of I_e)	%	115		
Minimum load (% of set motor current I_M)	%	8		
Maximum cable length between soft starter and motor	m	500 ¹⁾		
Permissible installation height	m	5000 (derating from 1000, see characteristic curves); higher on request		
Permissible mounting position				
Installation type	Stand-alone installation			
Permissible ambient temperature	°C	0 ... +60; (derating from +40)		
Operation	°C	-25 ... +80		
Storage	°C			
Degree of protection		IP00		
1) At the project configuration stage, it is important to make allowance for the voltage drop on the motor cable up to the motor connection. If necessary,		higher values for the rated operational voltage or current must be calculated accordingly for the soft starter.		

Type		3RW44 22	3RW44 23	3RW44 24	3RW44 25	3RW44 26	3RW44 27
Power electronics							
Rated operational current I_e		29	36	47	57	77	93
Load rating with rated operational current I_e							
• Acc. to IEC and UL/CSA ¹⁾ , for individual mounting, AC-53a							
- At 40 °C	A	29	36	47	57	77	93
- At 50 °C	A	26	32	42	51	68	82
- At 60 °C	A	23	29	37	45	59	72
Smallest adjustable rated motor current I_M	A	5	7	9	11	15	18
For the motor overload protection							
Power loss							
• In operation after completed starting with uninterrupted rated operational current (40 °C) approx.	W	8	10	32	36	45	55
• During starting with current limit set to 350 % I_M (40 °C)	W	400	470	600	725	940	1160
Permissible rated motor current and starts per hour							
• Normal starting (Class 5)							
- Rated motor current $I_M^{(2)}$, starting time 5 s	A	29	36	47	57	77	93
- Starts per hour ⁽³⁾	1/h	41	34	41	41	41	41
- Rated motor current $I_M^{(2)(4)}$, starting time 10 s	A	29	36	47	57	77	93
- Starts per hour ⁽³⁾	1/h	20	15	20	20	20	20
• Normal starting (Class 10)							
- Rated motor current $I_M^{(2)}$, starting time 10 s	A	29	36	47	57	77	93
- Starts per hour ⁽³⁾	1/h	20	15	20	20	20	20
- Rated motor current $I_M^{(2)(4)}$, starting time 20 s	A	29	36	47	57	77	93
- Starts per hour ⁽³⁾	1/h	10	6	10	10	8	8
• Normal starting (Class 15)							
- Rated motor current $I_M^{(2)}$, starting time 15 s	A	29	36	47	57	77	93
- Starts per hour ⁽³⁾	1/h	13	9	13	13	13	13
- Rated motor current $I_M^{(2)(4)}$, starting time 30 s	A	29	36	47	57	77	93
- Starts per hour ⁽³⁾	1/h	6	4	6	6	6	6
• For heavy starting (Class 20)							
- Rated motor current $I_M^{(2)}$, starting time 20 s	A	29	36	47	57	73	88
- Starts per hour ⁽³⁾	1/h	10	6	10	10	10	10
- Rated motor current $I_M^{(2)(4)}$, starting time 40 s	A	29	36	47	57	73	88
- Starts per hour ⁽³⁾	1/h	4	2	4	5	1.8	0.8
• For very heavy starting (Class 30)							
- Rated motor current $I_M^{(2)}$, starting time 30 s	A	29	36	44	57	65	77
- Starts per hour ⁽³⁾	1/h	6	4	6	6	6	6
- Rated motor current $I_M^{(2)(3)}$, starting time 60 s	A	29	36	44	57	65	77
- Starts per hour ⁽³⁾	1/h	1.8	0.8	3.3	1.5	2	1

1) Measurement at 60 °C according to UL/CSA not required.

2) Current limit on soft starter set to 350 % I_M .3) For intermittent duty S4 with ON period = 70 %, $T_U = 40$ °C, stand-alone installation vertical. The quoted switching frequencies do not apply for automatic mode.4) Maximum adjustable rated motor current I_M , dependent on CLASS setting.

For Operation in the Control Cabinet

3RW Soft Starters

3RW44 for high-feature applications

Type		3RW44 34	3RW44 35	3RW44 36
Power electronics				
Rated operational current I_e		113	134	162
Load rating with rated operational current I_e				
• Acc. to IEC and UL/CSA ¹⁾ , for individual mounting, AC-53a				
- At 40 °C	A	113	134	162
- At 50 °C	A	100	117	145
- At 60 °C	A	88	100	125
Smallest adjustable rated motor current I_M	A	22	26	32
For the motor overload protection				
Power loss				
• In operation after completed starting with uninterrupted rated operational current (40 °C) approx.	W	64	76	95
• During starting with current limit set to 350 % I_M (40 °C)	W	1350	1700	2460
Permissible rated motor current and starts per hour				
• Normal starting (Class 5)				
- Rated motor current $I_M^{(2)}$, starting time 5 s	A	113	134	162
- Starts per hour ³⁾	1/h	41	39	41
- Rated motor current $I_M^{(2)(4)}$, starting time 10 s	A	113	134	162
- Starts per hour ³⁾	1/h	20	15	20
• Normal starting (Class 10)				
- Rated motor current $I_M^{(2)}$, starting time 10 s	A	113	134	162
- Starts per hour ³⁾	1/h	20	15	20
- Rated motor current $I_M^{(2)(4)}$, starting time 20 s	A	113	134	162
- Starts per hour ³⁾	1/h	9	6	7
• Normal starting (Class 15)				
- Rated motor current $I_M^{(2)}$, starting time 15 s	A	113	134	162
- Starts per hour ³⁾	1/h	13	9	12
- Rated motor current $I_M^{(2)(4)}$, starting time 30 s	A	113	134	162
- Starts per hour ³⁾	1/h	6	6	1
• For heavy starting (Class 20)				
- Rated motor current $I_M^{(2)}$, starting time 20 s	A	106	125	147
- Starts per hour ³⁾	1/h	9	9	10
- Rated motor current $I_M^{(2)(4)}$, starting time 40 s	A	106	125	147
- Starts per hour ³⁾	1/h	1.5	2	1
• For very heavy starting (Class 30)				
- Rated motor current $I_M^{(2)}$, starting time 30 s	A	91	110	120
- Starts per hour ³⁾	1/h	6	6	6
- Rated motor current $I_M^{(2)(4)}$, starting time 60 s	A	91	110	120
- Starts per hour ³⁾	1/h	2	2	2

¹⁾ Measurement at 60 °C according to UL/CSA not required.

²⁾ Current limit on soft starter set to 350 % I_M .

³⁾ For intermittent duty S4 with ON period = 70 %, $T_u = 40$ °C, stand-alone installation vertical. The quoted switching frequencies do not apply for automatic mode.

⁴⁾ Maximum adjustable rated motor current I_M , dependent on CLASS setting.

For Operation in the Control Cabinet

3RW Soft Starters

3RW44 for high-feature applications

Type		3RW44 43	3RW44 44	3RW44 45	3RW44 46	3RW44 47
Power electronics						
Rated operational current I_e		203	250	313	356	432
Load rating with rated operational current I_e						
• Acc. to IEC and UL/CSA ¹⁾ , for individual mounting, AC-53a						
- At 40 °C	A	203	250	313	356	432
- At 50 °C	A	180	215	280	315	385
- At 60 °C	A	156	185	250	280	335
Smallest adjustable rated motor current I_M	A	40	50	62	71	86
For the motor overload protection						
Power loss						
• In operation after completed starting with uninterrupted rated operational current (40 °C) approx.	W	89	110	145	174	232
• During starting with current limit set to 350 % I_M (40 °C)	W	3350	4000	4470	5350	5860
Permissible rated motor current and starts per hour						
• Normal starting (Class 5)						
- Rated motor current $I_M^{2)}$, starting time 5 s	A	203	250	313	356	432
- Starts per hour ³⁾	1/h	41	41	41	41	39
- Rated motor current $I_M^{2)4)}$, starting time 10 s	A	203	250	313	356	432
- Starts per hour ³⁾	1/h	20	20	19	17	16
• Normal starting (Class 10)						
- Rated motor current $I_M^{2)}$, starting time 10 s	A	203	250	313	356	432
- Starts per hour ³⁾	1/h	20	20	19	17	16
- Rated motor current $I_M^{2)4)}$, starting time 20 s	A	203	250	313	356	432
- Starts per hour ³⁾	1/h	9	10	6	4	5
• Normal starting (Class 15)						
- Rated motor current $I_M^{2)}$, starting time 15 s	A	203	240	313	325	402
- Starts per hour ³⁾	1/h	13	13	10	13	11
- Rated motor current $I_M^{2)4)}$, starting time 30 s	A	203	240	313	325	402
- Starts per hour ³⁾	1/h	3	6	1	2	1
• For heavy starting (Class 20)						
- Rated motor current $I_M^{2)}$, starting time 20 s	A	195	215	275	285	356
- Starts per hour ³⁾	1/h	10	10	10	10	10
- Rated motor current $I_M^{2)4)}$, starting time 40 s	A	195	215	275	285	356
- Starts per hour ³⁾	1/h	1	5	1	3	1
• For very heavy starting (Class 30)						
- Rated motor current $I_M^{2)}$, starting time 30 s	A	162	180	220	240	285
- Starts per hour ³⁾	1/h	6	6	6	6	6
- Rated motor current $I_M^{2)4)}$, starting time 60 s	A	162	180	220	240	285
- Starts per hour ³⁾	1/h	3	3	3	2	1

1) Measurement at 60 °C according to UL/CSA not required.

2) Current limit on soft starter set to 350 % I_M .

3) For intermittent duty S4 with ON period = 70 %, $T_u = 40$ °C, stand-alone installation vertical. The quoted switching frequencies do not apply for automatic mode.

4) Maximum adjustable rated motor current I_M , dependent on CLASS setting.

For Operation in the Control Cabinet

3RW Soft Starters

3RW44 for high-feature applications

Type		3RW44 53	3RW44 54	3RW44 55	3RW44 56	3RW44 57	3RW44 58
Power electronics							
Rated operational current I_e		551	615	693	780	880	970
Load rating with rated operational current I_e							
• Acc. to IEC and UL/CSA ¹⁾ , for individual mounting, AC-53a							
- At 40 °C	A	551	615	693	780	880	970
- At 50 °C	A	494	551	615	693	780	850
- At 60 °C	A	438	489	551	615	693	760
Smallest adjustable rated motor current I_M	A	110	123	138	156	176	194
For the motor overload protection							
Power loss							
• In operation after completed starting with uninterrupted rated operational current (40 °C) approx.	W	159	186	220	214	250	270
• During starting with current limit set to 350 % I_M (40 °C)	W	7020	8100	9500	11100	13100	15000
Permissible rated motor current and starts per hour							
• Normal starting (Class 5)							
- Rated motor current $I_M^{(2)}$, starting time 5 s	A	551	615	693	780	880	970
- Starts per hour ³⁾	1/h	41	41	37	33	22	17
- Rated motor current $I_M^{(2)(4)}$, starting time 10 s	A	551	615	693	780	880	970
- Starts per hour ³⁾	1/h	20	20	16	13	8	5
• Normal starting (Class 10)							
- Rated motor current $I_M^{(2)}$, starting time 10 s	A	551	615	693	780	880	970
- Starts per hour ³⁾	1/h	20	20	16	13	8	5
- Rated motor current $I_M^{(2)(4)}$, starting time 20 s	A	551	615	693	780	880	970
- Starts per hour ³⁾	1/h	10	9	6	4	0.3	0.3
• Normal starting (Class 15)							
- Rated motor current $I_M^{(2)}$, starting time 15 s	A	551	615	666	723	780	821
- Starts per hour ³⁾	1/h	13	13	11	9	8	8
- Rated motor current $I_M^{(2)(4)}$, starting time 30 s	A	551	615	666	723	780	821
- Starts per hour ³⁾	1/h	6	4	3	1	0.4	0.5
• For heavy starting (Class 20)							
- Rated motor current $I_M^{(2)}$, starting time 20 s	A	551	591	633	670	710	740
- Starts per hour ³⁾	1/h	10	10	7	8	8	9
- Rated motor current $I_M^{(2)(4)}$, starting time 40 s	A	551	591	633	670	710	740
- Starts per hour ³⁾	1/h	4	2	1	1	0.4	1
• For very heavy starting (Class 30)							
- Rated motor current $I_M^{(2)}$, starting time 30 s	A	500	525	551	575	600	630
- Starts per hour ³⁾	1/h	6	6	6	6	6	6
- Rated motor current $I_M^{(2)(4)}$, starting time 60 s	A	500	525	551	575	600	630
- Starts per hour ³⁾	1/h	2	1	1	1	1.5	1

¹⁾ Measurement at 60 °C according to UL/CSA not required.

²⁾ Current limit on soft starter set to 350 % I_M .

³⁾ For intermittent duty S4 with ON period = 70 %, $T_u = 40$ °C, stand-alone installation vertical. The quoted switching frequencies do not apply for automatic mode.

⁴⁾ Maximum adjustable rated motor current I_M , dependent on CLASS setting.

For Operation in the Control Cabinet

3RW Soft Starters

3RW44 for high-feature applications

Type		3RW44 65	3RW44 66
Power electronics			
Rated operational current I_e		1076	1214
Load rating with rated operational current I_e			
• Acc. to IEC and UL/CSA ¹⁾ , for individual mounting, AC-53a			
- At 40 °C	A	1076	1214
- At 50 °C	A	970	1076
- At 60 °C	A	880	970
Smallest adjustable rated motor current I_M	A	215	242
For the motor overload protection			
Power loss			
• In operation after completed starting with uninterrupted rated operational current (40 °C) approx.	W	510	630
• During starting with current limit set to 350 % I_M (40 °C)	W	15000	17500
Permissible rated motor current and starts per hour			
• Normal starting (Class 5)			
- Rated motor current $I_M^{2)}$, starting time 5 s	A	1076	1214
- Starts per hour ³⁾	1/h	30	20
- Rated motor current $I_M^{2)4)}$, starting time 10 s	A	1076	1214
- Starts per hour ³⁾	1/h	10	6
• Normal starting (Class 10)			
- Rated motor current $I_M^{2)}$, starting time 10 s	A	1076	1214
- Starts per hour ³⁾	1/h	11	6
- Rated motor current $I_M^{2)4)}$, starting time 20 s	A	1076	1214
- Starts per hour ³⁾	1/h	3	0.5
• Normal starting (Class 15)			
- Rated motor current $I_M^{2)}$, starting time 15 s	A	1020	1090
- Starts per hour ³⁾	1/h	7	5
- Rated motor current $I_M^{2)4)}$, starting time 30 s	A	1020	1090
- Starts per hour ³⁾	1/h	1	1
• For heavy starting (Class 20)			
- Rated motor current $I_M^{2)}$, starting time 20 s	A	970	1030
- Starts per hour ³⁾	1/h	7	5
- Rated motor current $I_M^{2)4)}$, starting time 40 s	A	970	1030
- Starts per hour ³⁾	1/h	1	1
• For very heavy starting (Class 30)			
- Rated motor current $I_M^{2)}$, starting time 30 s	A	880	920
- Starts per hour ³⁾	1/h	6	6
- Rated motor current $I_M^{2)4)}$, starting time 60 s	A	880	920
- Starts per hour ³⁾	1/h	1	1

1) Measurement at 60 °C according to UL/CSA not required.

2) Current limit on soft starter set to 350 % I_M .





3) For intermittent duty S4 with ON period = 70 %, $T_u = 40$ °C, stand-alone installation vertical. The quoted switching frequencies do not apply for automatic mode.

4) Maximum adjustable rated motor current I_M , dependent on CLASS setting.

For Operation in the Control Cabinet

3RW Soft Starters

3RW44 for high-feature applications

Type			3RW44 2.	3RW44 3.	3RW44 4.	3RW44 5. 3RW44 6.	
Conductor cross-sections							
Screw terminals	Main conductors						
With box terminal				3RT19 55-4G (55 kW)	3RT19 66-4G	--	
Front clamping point connected 	• Finely stranded with end sleeve	mm ²	2.5 ... 35	16 ... 70	70 ... 240	--	
	• Finely stranded without end sleeve	mm ²	4 ... 50	16 ... 70	70 ... 240	--	
	• Solid	mm ²	2.5 ... 16	--	--	--	
	• Stranded	mm ²	4 ... 70	16 ... 70	95 ... 300	--	
	• Ribbon cable conductors (number x width x thickness)	mm	6 x 9 x 0.8	Min. 3 x 9 x 0.8 Max. 6 x 15.5 x 0.8	Min. 6 x 9 x 0.8 Max. 20 x 24 x 0.5	--	
	• AWG cables, solid or stranded	AWG	10 ... 2/0	6 ... 2/0	3/0 ... 600 kcmil	--	
Rear clamping point connected 	• Finely stranded with end sleeve	mm ²	2.5 ... 50	16 ... 70	120 ... 185	--	
	• Finely stranded without end sleeve	mm ²	10 ... 50	16 ... 70	120 ... 185	--	
	• Solid	mm ²	2.5 ... 16	--	--	--	
	• Stranded	mm ²	10 ... 70	16 ... 70	120 ... 240	--	
	• Ribbon cable conductors (number x width x thickness)	mm	6 x 9 x 0.8	Min. 3 x 9 x 0.8 Max. 6 x 15.5 x 0.8	Min. 6 x 9 x 0.8 Max. 20 x 24 x 0.5	--	
	• AWG cables, solid or stranded	AWG	10 ... 2/0	6 ... 2/0	250 ... 500 kcmil	--	
Both clamping points connected 	• Finely stranded with end sleeve	mm ²	2 x (2.5 ... 35)	Max. 1 x 50, 1 x 70	Min. 2 x 50 Max. 2 x 185	--	
	• Finely stranded without end sleeve	mm ²	2 x (4 ... 35)	Max. 1 x 50, 1 x 70	Min. 2 x 50 Max. 2 x 185	--	
	• Solid	mm ²	2 x (2.5 ... 16)	--	--	--	
	• Stranded	mm ²	2 x (4 ... 50)	Max. 2 x 70	Max. 2 x 70 Max. 2 x 240	--	
	• Ribbon cable conductors (number x width x thickness)	mm	2 x (6 x 9 x 0.8)	Max. 2 x (6 x 15.5 x 0.8)	Max. 2 x (20 x 24 x 0.5)	--	
	• AWG cables, solid or stranded	AWG	2 x (10 ... 1/0)	Max. 2 x 1/0	Min. 2 x 2/0 Max. 2 x 500 kcmil	--	
	• Terminal screws		M6 (hexagon socket, A/F4)	M10 (hexagon socket, A/F4)	M12 (hexagon socket, A/F5)	--	
	- Tightening torque	NM lb.in	4 ... 6 36 ... 53	10 ... 12 90 ... 110	20 ... 22 180 ... 195	--	
	Screw terminals	Main conductors					
	With box terminal				3RT19 56-4G	--	--
Front or rear clamping point connected 	• Finely stranded with end sleeve	mm ²	--	16 ... 120	--	--	
	• Finely stranded without end sleeve	mm ²	--	16 ... 120	--	--	
	• Stranded	mm ²	--	16 ... 120	--	--	
	• Ribbon cable conductors (number x width x thickness)	mm	--	Min. 3 x 9 x 0.8 Max. 6 x 15.5 x 0.8	--	--	
• AWG cables, solid or stranded	AWG	--	6 ... 250 kcmil	--	--		
Both clamping points connected 	• Finely stranded with end sleeve	mm ²	--	Max. 1 x 95, 1 x 120	--	--	
	• Finely stranded without end sleeve	mm ²	--	Max. 1 x 95, 1 x 120	--	--	
	• Stranded	mm ²	--	Max. 2 x 120	--	--	
	• Ribbon cable conductors (number x width x thickness)	mm	--	Max. 2 x (10 x 15.5 x 0.8)	--	--	
	• AWG cables, solid or stranded	AWG	--	Max. 2 x 3/0	--	--	
	Screw terminals	Main conductors					
	<u>Without box terminal/busbar connection</u>						
• Finely stranded with cable lug	mm ²	--	16 ... 95 ¹⁾	50 ... 240 ²⁾	50 ... 240 ²⁾		
• Stranded with cable lug	mm ²	--	25 ... 120 ¹⁾	70 ... 240 ²⁾	70 ... 240 ²⁾		
• AWG cables, solid or stranded	AWG	--	4 ... 250 kcmil	2/0 ... 500 kcmil	2/0 ... 500 kcmil		
• Connecting bar (max. width)	mm	--	17	25	60		
• Terminal screws		--	M8 x 25 (A/F13)	M10 x 30 (A/F17)	M12 x 40		
- Tightening torque	NM lb.in	--	10 ... 14 89 ... 124	14 ... 24 124 ... 210	20 ... 35 177 ... 310		

¹⁾ When connecting cable lugs to DIN 46235, use 3RT19 56-4EA1 terminal cover for conductor cross-sections from 95 mm² to ensure phase spacing.

²⁾ When connecting cable lugs to DIN 46234, the 3RT19 66-4EA1 terminal cover must be used for conductor cross-sections of 240 mm² and more as well as DIN 46235 for conductor cross-sections of 185 mm² and more to keep the phase clearance.

For Operation in the Control Cabinet

3RW Soft Starters

3RW44 for high-feature applications

Soft starters	Type	3RW44..	
Conductor cross-sections			
Auxiliary conductors (1 or 2 conductors can be connected):			
Screw terminals			
• Solid	mm ²	2 x (0.5 ... 2.5)	
• Finely stranded with end sleeve	mm ²	2 x (0.5 ... 1.5)	
• AWG cables			
- Solid or stranded	AWG	2 x (20 ... 14)	
- Finely stranded with end sleeve	AWG	2 x (20 ... 16)	
• Terminal screws			
- Tightening torque	NM lb.in	0.8 ... 1.2 7 ... 10.3	
Spring-type terminals			
• Solid	mm ²	2 x (0.25 ... 1.5)	
• Finely stranded with end sleeve	mm ²	2 x (0.25 ... 1.5)	
• AWG cables, solid or stranded	AWG	2 x (24 ... 16)	
		Standard	Parameters
Electromagnetic compatibility acc. to EN 60947-4-2			
<i>EMC interference immunity</i>			
Electrostatic discharge (ESD)		EN 61000-4-2	±4 kV contact discharge, ±8 kV air discharge
Electromagnetic RF fields		EN 61000-4-3	Frequency range: 80 ... 1000 MHz with 80 % at 1 kHz Degree of severity 3, 10 V/m
Conducted RF interference		EN 61000-4-6	Frequency range: 150 kHz ... 80 MHz with 80 % at 1 kHz Interference 10 V
RF voltages and RF currents on cables			
• Burst		EN 61000-4-4	±2 kV/5 kHz
• Surge		EN 61000-4-5	±1 kV line to line ±2 kV line to ground
<i>EMC interference emission</i>			
EMC interference field strength		EN 55011	Limit value of Class A at 30 ... 1000 MHz
Radio interference voltage		EN 55011	Limit value of Class A at 0.15 ... 30 MHz
<i>Is an RI suppression filter necessary?</i>			
Degree of noise suppression A (industrial applications)			No

For Operation in the Control Cabinet

3RW Soft Starters

3RW44 for high-feature applications

Fuse assignment

The type of coordination to which the motor feeder with soft starter is mounted depends on the application-specific requirements. Normally, fuseless mounting (combination of motor starter protector/circuit breaker and soft starter) is sufficient. If type of coordination "2" is to be fulfilled, semiconductor fuses must be fitted in the motor feeder.

Inline circuit fuseless version

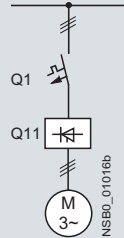

Soft starters

TOC 1

Q11
Type

Rated current
A

Motor starter protectors/circuit breakers¹⁾

440 V + 10 %
Q1
Type
A

Type of coordination "1"²⁾: 3RW44 22 ... 3RW44 27: $I_q = 32 \text{ kA}$; 3RW44 34 and 3RW44 35: $I_q = 16 \text{ kA}$; 3RW44 36 ... 3RW44 66: $I_q = 65 \text{ kA}$

3RW44 22	29	3RV10 42-4HA10	50
3RW44 23	36	3RV10 42-4JA10	63
3RW44 24	47	3RV10 42-4KA10	75
3RW44 25	57	3RV10 42-4LA10	90
3RW44 26	77	3RV10 42-4MA10	100
3RW44 27	93	3RV10 42-4MA10	100
3RW44 34	113	3VL17 16-2DD36	160
3RW44 35	134	3VL17 16-2DD36	160
3RW44 36	162	3VL37 25-2DC36	250
3RW44 43	203	3VL47 31-3DC36	315
3RW44 44	250	3VL47 31-3DC36	315
3RW44 45	313	3VL47 40-3DC36	400
3RW44 46	356	3VL47 40-3DC36	400
3RW44 47	432	3VL57 50-3DC36	500
3RW44 53	551	3VL67 80-3AB36	800
3RW44 54	615	3VL67 80-3AB36	800
3RW44 55	693	3VL67 80-3AB36	800
3RW44 56	780	3VL77 10-3AB36	1000
3RW44 57	880	3VL77 10-3AB36	1000
3RW44 58	970	3VL77 12-3AB36	1250
3RW44 65	1076	3VL77 12-3AB36	1250
3RW44 66	1214	3VL77 12-3AB36	1250

¹⁾ The rated motor current must be considered when selecting the devices.

²⁾ The types of coordination are explained under "3RA1 Fuseless Load Feeders".

TOC 1

Type of coordination "1"

TOC 2

Type of coordination "2"

The types of coordination are explained in more detail under "3RA1 Fuseless Load Feeders".

These types of coordination are indicated in the Technical specifications by orange backgrounds.

For Operation in the Control Cabinet

3RW Soft Starters

3RW44 for high-feature applications

Inline circuit fused version (line protection only)

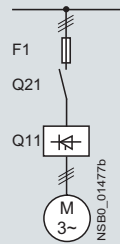

Soft starters Q11 Type	Rated current A	Line protection, maximum			Line contactors up to 400 V (optional) Q21 Type	Braking contactors ¹⁾²⁾ (for example circuit see page 6/61) Q91 Type Q92 Type	
		690 V +5 % F1 Type	Rated current A	Size			
Type of coordination "1"³⁾: $I_q = 65 \text{ kA}$							
3RW44 22	29	3NA3 820-6	50	00	3RT10 34	3RT15 26	--
3RW44 23	36	3NA3 822-6	63	00	3RT10 35	3RT15 26	--
3RW44 24	47	3NA3 824-6	80	00	3RT10 36	3RT15 35	--
3RW44 25	57	3NA3 830-6	100	00	3RT10 44	3RT15 35	--
3RW44 26	77	3NA3 132-6	125	1	3RT10 45	3RT10 24	3RT10 35
3RW44 27	93	3NA3 136-6	160	1	3RT10 46	3RT10 25	3RT10 36
3RW44 34	113	3NA3 244-6	250	2	3RT10 54	3RT10 34	3RT10 44
3RW44 35	134	3NA3 244-6	250	2	3RT10 55	3RT10 36	3RT10 45
3RW44 36	162	3NA3 365-6	500	3	3RT10 56	3RT10 44	3RT10 45
3RW44 43	203	2 x 3NA3 354-6	2 x 355	3	3RT10 64	3RT10 44	3RT10 54
3RW44 44	250	2 x 3NA3 354-6	2 x 355	3	3RT10 65	3RT10 44	3RT10 55
3RW44 45	313	2 x 3NA3 365-6	2 x 500	3	3RT10 75	3RT10 54	3RT10 56
3RW44 46	356	2 x 3NA3 365-6	2 x 500	3	3RT10 75	3RT10 54	3RT10 56
3RW44 47	432	2 x 3NA3 365-6	2 x 500	3	3RT10 76	3RT10 55	3RT10 64
3RW44 53	551	2 x 3NA3 365-6	2 x 500	3	3TF68	3RT10 64	3RT10 66
3RW44 54	615	2 x 3NA3 365-6	2 x 500	3	3TF68	3RT10 64	3RT10 75
3RW44 55	693	2 x 3NA3 365-6	2 x 500	3	3TF69	3RT10 65	3RT10 75
3RW44 56	780	2 x 3NA3 365-6	2 x 500	3	3TF69	3RT10 65	3RT10 75
3RW44 57	880	2 x 3NA3 365-6	2 x 500	3		3RT10 75	3RT10 76
3RW44 58	970	3 x 3NA3 365-6	3 x 500	3		3RT10 75	3RT10 76
3RW44 65	1076	3 x 3NA3 365-6	3 x 500	3		3RT10 75	3TF68
3RW44 66	1214	3 x 3NA3 365-6	3 x 500	3		3RT10 76	3TF68

1) If the ramp-down function "Combined braking" is selected, no braking contactor is required.
If the ramp-down function "DC braking" is selected, a braking contactor must be used in addition (see table for type).
For applications with large centrifugal masses ($J_{\text{Load}} > J_{\text{Motor}}$) we recommend the function "DC braking".

2) Additional auxiliary relay K4:
LZX:RT4A4T30
(3RW44 soft starter with rated control supply voltage 230 V AC),
LZX:RT4A4S15
(3RW44 soft starter with rated control supply voltage 115 V AC).

3) The type of coordination "1" refers only to soft starters in combination with the stipulated protective device (motor starter protector/circuit breaker/fuse), not to any additional components in the feeder.
The types of coordination are explained under "3RA1 Fuseless Load Feeders".

For Operation in the Control Cabinet

3RW Soft Starters

3RW44 for high-feature applications

Inline circuit fused version with 3NE1 SITOR all-range fuse (semiconductor and line protection)

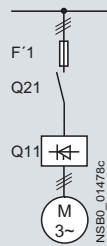

For matching fuse bases see Catalog LV 1 under "SETRON Switching and Protection Devices for Power Distribution" → "Switch Disconnectors", and Catalog ET B1 under "BETA Protecting" → "SITOR Semiconductor Fuses" or go to www.siemens.com/sitor → "Products" → "BETA Protecting" → "SITOR"

Soft starters Q11 Type	Rated current A	All-range fuses				Line contactors up to 400 V (optional) Q21 Type	Braking contactors ¹⁾²⁾ (for example circuit see page 6/61) Q91 Type		Q92 Type
		F1 Type	Rated current A	Voltage V	Size				
Type of coordination "2"³⁾: $I_q = 65 \text{ kA}$									
3RW44 22	29	3NE1 020-2	80	690 +5 %	00	3RT10 34	3RT15 26	--	
3RW44 23	36	3NE1 020-2	80	690 +5 %	00	3RT10 35	3RT15 26	--	
3RW44 24	47	3NE1 021-2	100	690 +5 %	00	3RT10 36	3RT15 35	--	
3RW44 25	57	3NE1 022-2	125	690 +5 %	00	3RT10 44	3RT15 35	--	
3RW44 26	77	3NE1 022-2	125	690 +5 %	00	3RT10 45	3RT10 24	3RT10 35	
3RW44 27	93	3NE1 024-2	160	690 +5 %	1	3RT10 46	3RT10 25	3RT10 36	
3RW44 34	113	3NE1 225-2	200	690 +5 %	1	3RT10 54	3RT10 34	3RT10 44	
3RW44 35	134	3NE1 227-2	250	690 +5 %	1	3RT10 55	3RT10 36	3RT10 45	
3RW44 36	162	3NE1 227-2	250	690 +5 %	1	3RT10 56	3RT10 44	3RT10 45	
3RW44 43	203	3NE1 230-2	315	600 +10 %	1	3RT10 64	3RT10 44	3RT10 54	
3RW44 44	250	3NE1 331-2	350	460 +10 %	2	3RT10 65	3RT10 44	3RT10 55	
3RW44 45	313	3NE1 333-2	450	690 +5 %	2	3RT10 75	3RT10 54	3RT10 56	
3RW44 46	356	3NE1 334-2	500	690 +5 %	2	3RT10 75	3RT10 54	3RT10 56	
3RW44 47	432	3NE1 435-2	560	690 +5 %	3	3RT10 76	3RT10 55	3RT10 64	
3RW44 53	551	2 x 3NE1 334-2	500	690 +10 %	2	3TF68	3RT10 64	3RT10 66	
3RW44 54	615	2 x 3NE1 334-2	500	690 +10 %	2	3TF68	3RT10 64	3RT10 75	
3RW44 55	693	2 x 3NE1 334-2	500	690 +10 %	2	3TF69	3RT10 65	3RT10 75	
3RW44 56	780	2 x 3NE1 435-2	560	690 +10 %	3	3TF69	3RT10 65	3RT10 75	
3RW44 57	880	2 x 3NE1 435-2	560	690 +10 %	3		3RT10 75	3RT10 76	
3RW44 58	970	2 x 3NE1 435-2	560	690 +10 %	3		3RT10 75	3RT10 76	
3RW44 65	1076	3 x 3NE1 334-2	500	690 +10 %	2		3RT10 75	3TF68	
3RW44 66	1214	3 x 3NE1 435-2	560	690 +10 %	3		3RT10 76	3TF68	

¹⁾ If the ramp-down function "Combined braking" is selected, no braking contactor is required.
If the ramp-down function "DC braking" is selected, a braking contactor must be used in addition (see table for type).
For applications with large centrifugal masses ($J_{Load} > J_{Motor}$) we recommend the function "DC braking".

²⁾ Additional auxiliary relay K4:
LZX:RT4A4T30
(3RW44 soft starter with rated control supply voltage 230 V AC),
LZX:RT4A4S15
(3RW44 soft starter with rated control supply voltage 115 V AC).

³⁾ The type of coordination "2" refers only to soft starters in combination with the stipulated protective device (motor starter protector/circuit breaker/fuse), not to any additional components in the feeder.
The types of coordination are explained under "3RA1 Fuseless Load Feeders".

For Operation in the Control Cabinet

3RW Soft Starters

3RW44 for high-feature applications

Inline circuit fused version with 3NE or 3NC SITOR semiconductor fuse
(semiconductor protection by fuse, line and overload protection by motor starter protector/circuit breaker)

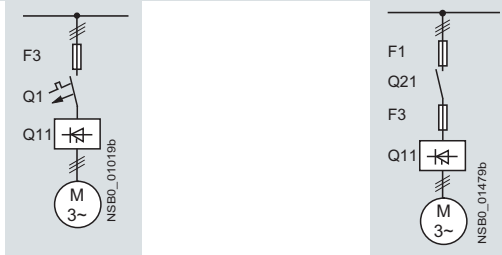

For matching fuse bases see Catalog LV 1 under "SENTRON Switching and Protection Devices for Power Distribution" —> "Switch Disconnectors", and Catalog ET B1 under "BETA Protecting" —> "SITOR Semiconductor Fuses" or go to www.siemens.com/sitor —> "Products" —> "BETA Protecting" —> "SITOR"

Soft starters Q11 Type	Rated current A	Semiconductor fuses, minimum			Semiconductor fuses, maximum			Semiconductor fuses (cylinder)		
		Rated current A	Size	Rated current A	Size	Rated current A	Size	Rated current A	Size	
Type of coordination "2"^{m3}: I_q = 65 kA										
3RW44 22	29	3NE4 120	80	0	3NE4 121	100	0	3NC2 280	80	22 x 58
3RW44 23	36	3NE4 121	100	0	3NE4 121	100	0	3NC2 200	100	22 x 58
3RW44 24	47	3NE4 121	100	0	3NE4 122	125	0	3NC2 200	100	22 x 58
3RW44 25	57	3NE4 122	125	0	3NE4 124	160	0			
3RW44 26	77	3NE4 124	160	0	3NE4 124	160	0			
3RW44 27	93	3NE3 224	160	1	3NE3 332-0B	400	2			
3RW44 34	113	3NE3 225	200	1	3NE3 335	560	2			
3RW44 35	134	3NE3 225	200	1	3NE3 335	560	2			
3RW44 36	162	3NE3 227	250	1	3NE3 333	450	2			
3RW44 43	203	3NE3 230-0B	315	1	3NE3 333	450	2			
3RW44 44	250	3NE3 230-0B	315	1	3NE3 333	450	2			
3RW44 45	313	3NE3 233	450	1	3NE3 336	630	2			
3RW44 46	356	3NE3 333	450	2	3NE3 336	630	2			
3RW44 47	432	3NE3 335	560	2	3NE3 338-8	800	2			
3RW44 53	551	2 x 3NE3 335	560	2	3 x 3NE3 334-0B	500	2			
3RW44 54	615	2 x 3NE3 335	560	2	3 x 3NE3 334-0B	500	2			
3RW44 55	693	2 x 3NE3 335	560	2	3 x 3NE3 334-0B	500	2			
3RW44 56	780	2 x 3NE3 336	630	2	2 x 3NE3 340-8	900	2			
3RW44 57	880	2 x 3NE3 336	630	2	2 x 3NE3 340-8	900	2			
3RW44 58	970	2 x 3NE3 336	630	2	2 x 3NE3 340-8	900	2			
3RW44 65	1076	2 x 3NE3 340-8	900	2	3 x 3NE3 338-8	800	2			
3RW44 66	1214	2 x 3NE3 340-8	900	2	3 x 3NE3 338-8	800	2			

Soft starters Q11 Type	Rated current A	Line contactors up to 400 V (optional) Q21 Type	Braking contactors ¹⁾²⁾ (for example circuit see page 6/61) Q91 Type		Motor starter protectors/ circuit breakers Q1 Type		Line protection, maximum		
			Q92 Type	Rated current A	Rated current A	Rated current A	Size		
Type of coordination "2"^{m3}: I_q = 65 kA									
3RW44 22	29	3RT10 34	3RT15 26	--	3RV10 41-4HA10	50	3NA3 820-6	50	00
3RW44 23	36	3RT10 35	3RT15 26	--	3RV10 41-4JA10	63	3NA3 822-6	63	00
3RW44 24	47	3RT10 36	3RT15 35	--	3RV10 41-4KA10	75	3NA3 824-6	80	00
3RW44 25	57	3RT10 44	3RT15 35	--	3RV10 41-4LA10	90	3NA3 830-6	100	00
3RW44 26	77	3RT10 45	3RT10 24	3RT10 35	3RV10 41-4MA10	100	3NA3 132-6	125	1
3RW44 27	93	3RT10 46	3RT10 25	3RT10 36	3RV10 41-4MA10	100	3NA3 136-6	160	1
3RW44 34	113	3RT10 54	3RT10 34	3RT10 44	3VL17 16	160	3NA3 244-6	250	2
3RW44 35	134	3RT10 55	3RT10 36	3RT10 45	3VL17 16	160	3NA3 244-6	250	2
3RW44 36	162	3RT10 56	3RT10 44	3RT10 45	3VL37 25	250	3NA3 365-6	500	3
3RW44 43	203	3RT10 64	3RT10 44	3RT10 54	3VL47 31	315	2 x 3NA3 354-6	2 x 355	3
3RW44 44	250	3RT10 65	3RT10 44	3RT10 55	3VL47 31	315	2 x 3NA3 354-6	2 x 355	3
3RW44 45	313	3RT10 75	3RT10 54	3RT10 56	3VL47 40	400	2 x 3NA3 365-6	2 x 500	3
3RW44 46	356	3RT10 75	3RT10 54	3RT10 56	3VL47 40	400	2 x 3NA3 365-6	2 x 500	3
3RW44 47	432	3RT10 76	3RT10 55	3RT10 64	3VL57 50	500	2 x 3NA3 365-6	2 x 500	3
3RW44 53	551	3TF68	3RT10 64	3RT10 66	3VL67 80	800	2 x 3NA3 365-6	2 x 500	3
3RW44 54	615	3TF68	3RT10 64	3RT10 75	3VL67 80	800	2 x 3NA3 365-6	2 x 500	3
3RW44 55	693	3TF69	3RT10 65	3RT10 75	3VL67 80	800	2 x 3NA3 365-6	2 x 500	3
3RW44 56	780	3TF69	3RT10 65	3RT10 75	3VL77 10	1000	2 x 3NA3 365-6	2 x 500	3
3RW44 57	880		3RT10 75	3RT10 76	3VL77 10	1000	2 x 3NA3 365-6	2 x 500	3
3RW44 58	970		3RT10 75	3RT10 76	3VL77 12	1250	3 x 3NA3 365-6	3 x 500	3
3RW44 65	1076		3RT10 75	3TF68	3VL77 12	1250	3 x 3NA3 365-6	3 x 500	3
3RW44 66	1214		3RT10 76	3TF68	3VL77 12	1250	3 x 3NA3 365-6	3 x 500	3

1) If the ramp-down function "Combined braking" is selected, no braking contactor is required. If the ramp-down function "DC braking" is selected, a braking contactor must be used in addition (see table for type). For applications with large centrifugal masses ($J_{Load} > J_{Motor}$) we recommend the function "DC braking".

2) Additional auxiliary relay K4:
LZX:RT4A4T30
(3RW44 soft starter with rated control supply voltage 230 V AC),
LZX:RT4A4S15
(3RW44 soft starter with rated control supply voltage 115 V AC).

3) The type of coordination "2" refers only to soft starters in combination with the stipulated protective device (motor starter protector/circuit breaker/fuse), not to any additional components in the feeder. The types of coordination are explained under "3RA1 Fuseless Load Feeders".

For Operation in the Control Cabinet

3RW Soft Starters

3RW44 for high-feature applications

Inside-delta circuit fused version with 3NE or 3NC SITOR fuses
(semiconductor protection by fuse, lead and overload protection by motor starter protector/circuit breaker)

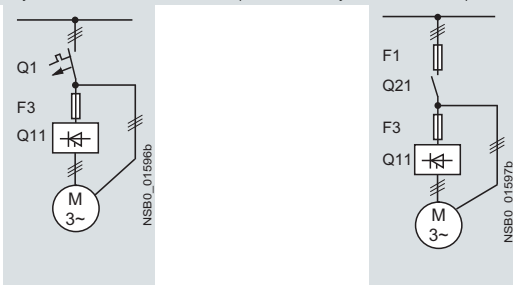

For matching fuse bases see Catalog LV 1 under "SENTRON Switching and Protection Devices for Power Distribution" → "Switch Disconnectors", and Catalog ET B1 under "BETA Protecting" → "SITOR Semiconductor Fuses" or go to www.siemens.com/sitor → "Products" → "BETA Protecting" → "SITOR"

Soft starters Q11 Type	Rated current A	Semiconductor fuses, minimum			Semiconductor fuses, maximum			Semiconductor fuses (cylinder)		
		F3 Type	Rated current A	Size	F3 Type	Rated current A	Size	F3 Type	Rated current A	Size
Type of coordination "2"¹⁾										
3RW44 22	50	3NE4 120	80	0	3NE4 121	100	0	3NC2 280	80	22 x 58
3RW44 23	62	3NE4 121	100	0	3NE4 121	100	0	3NC2 200	100	22 x 58
3RW44 24	81	3NE4 121	100	0	3NE4 122	125	0	3NC2 200	100	22 x 58
3RW44 25	99	3NE4 122	125	0	3NE4 124	160	0			
3RW44 26	133	3NE4 124	160	0	3NE4 124	160	0			
3RW44 27	161	3NE3 224	160	1	3NE3 332-0B	400	2			
3RW44 34	196	3NE3 225	200	1	3NE3 335	560	2			
3RW44 35	232	3NE3 225	200	1	3NE3 335	560	2			
3RW44 36	281	3NE3 227	250	1	3NE3 333	450	2			
3RW44 43	352	3NE3 230-0B	315	1	3NE3 333	450	2			
3RW44 44	433	3NE3 230-0B	315	1	3NE3 333	450	2			
3RW44 45	542	3NE3 233	450	1	3NE3 336	630	2			
3RW44 46	617	3NE3 333	450	2	3NE3 336	630	2			
3RW44 47	748	3NE3 335	560	2	3NE3 338-8	800	2			
3RW44 53	954	2 x 3NE3 335	560	2	3 x 3NE3 334-0B	500	2			
3RW44 54	1065	2 x 3NE3 335	560	2	3 x 3NE3 334-0B	500	2			
3RW44 55	1200	2 x 3NE3 335	560	2	3 x 3NE3 334-0B	500	2			
3RW44 56	1351	2 x 3NE3 336	630	2	2 x 3NE3 340-8	900	2			
3RW44 57	1524	2 x 3NE3 336	630	2	3 x 3NE3 340-8	900	2			
3RW44 58	1680	2 x 3NE3 336	630	2	3 x 3NE3 340-8	900	2			
3RW44 65	1864	2 x 3NE3 340-8	900	2	3 x 3NE3 338-8	800	2			
3RW44 66	2103	2 x 3NE3 340-8	900	2	3 x 3NE3 338-8	800	2			

Soft starters Q11 Type	Rated current A	Line contactors up to 400 V (optional)		Motor starter protectors/circuit breakers		Line protection, maximum		
		Q21 Type	Q1 Type	Rated current A	F1 Type	Rated current A	Size	
Type of coordination "2"¹⁾								
3RW44 22	50	3RT10 36-1AP04	3RV10 42-4KA10	75	3NA3 824-6	80	00	
3RW44 23	62	3RT10 44-1AP04	3RV10 42-4LA10	90	3NA3 830-6	100	00	
3RW44 24	81	3RT10 46-1AP04	3RV10 42-4MA10	100	3NA3 132-6	125	1	
3RW44 25	99	3RT10 54-1AP36	3VL27 16	160	3NA3 136-6	160	1	
3RW44 26	133	3RT10 55-6AP36	3VL27 16	160	3NA3 240-6	200	2	
3RW44 27	161	3RT10 56-6AP36	3VL37 20	200	3NA3 244-6	250	2	
3RW44 34	196	3RT10 64-6AP36	3VL37 25	250	3NA3 360-6	400	3	
3RW44 35	232	3RT10 65-6AP36	3VL47 31	315	3NA3 360-6	400	3	
3RW44 36	281	3RT10 66-6AP36	3VL47 40	400	2 x 3NA3 360-6	2 x 400	3	
3RW44 43	352	3RT10 75-6AP36	3VL47 40	400	2 x 3NA3 365-6	2 x 500	3	
3RW44 44	433	3RT10 76-6AP36	3VL57 50	500	2 x 3NA3 365-6	2 x 500	3	
3RW44 45	542	3TF68 44-0CM7	3VL57 63	800	3 x 3NA3 365-6	3 x 500	3	
3RW44 46	617	3TF68 44-0CM7	3VL67 80	800	3 x 3NA3 365-6	3 x 500	3	
3RW44 47	748	3TF69	3VL67 80	800	3 x 3NA3 365-6	3 x 500	3	
3RW44 53	954		3VL77 10	1000	3 x 3NA3 365-6	3 x 500	3	
3RW44 54	1065		3VL77 12	1250	3 x 3NA3 365-6	3 x 500	3	
3RW44 55	1200		3VL87 16	1600	3 x 3NA3 365-6	3 x 500	3	
3RW44 56	1351		3VL87 16	1600	3 x 3NA3 372	3 x 630	3	
3RW44 57	1524		3VL87 16	1600	3 x 3NA3 372	3 x 630	3	
3RW44 58	1680		3WL12 20	2000	2 x 3NA3 480	2 x 1000	4	
3RW44 65	1864		3WL12 25	2500	2 x 3NA3 482	2 x 1250	4	
3RW44 66	2103		3WL12 25	2500	2 x 3NA3 482	2 x 1250	4	

¹⁾ The type of coordination "2" refers only to soft starters in combination with the stipulated protective device (motor starter protector/circuit breaker/fuse), not to any additional components in the feeder.

The types of coordination are explained under "3RA1 Fuseless Load Feeders".

For Operation in the Control Cabinet

3RW Soft Starters

3RW44 for high-feature applications

Characteristic curves

Motor protection tripping characteristics for 3RW44 (with symmetry)

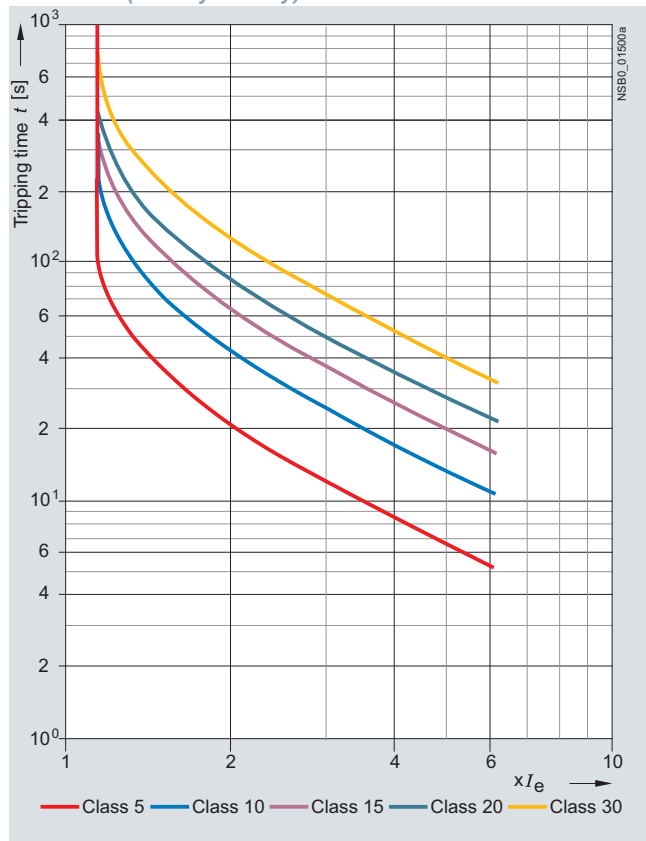

Motor protection tripping characteristics for 3RW44 (with asymmetry)

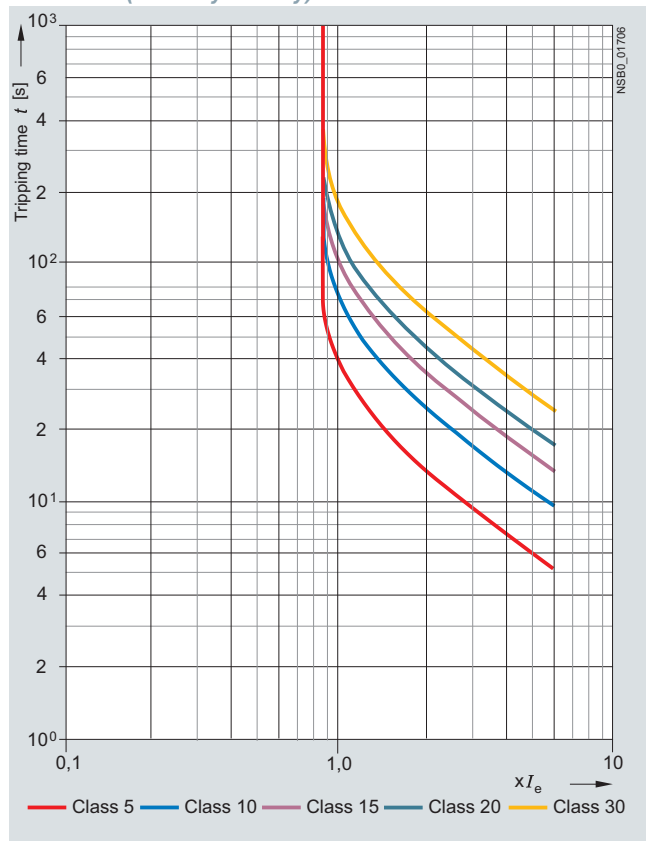

Permissible installation height

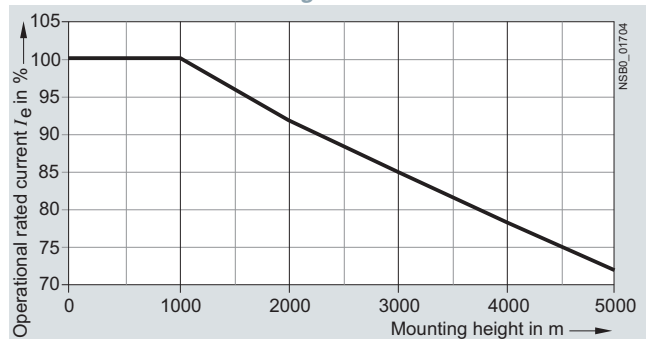

At an installation height above 2000 m, the max. permissible operational voltage is reduced to 460 V.

6

For Operation in the Control Cabinet

3RW Soft Starters

3RW44 for high-feature applications

More information

Application examples for normal starting (Class 10)

Normal starting Class 10 (up to 20 s with 350 % $I_{n \text{ motor}}$).

The soft starter rating can be selected to be as high as the rating of the motor used

Application	Conveyor belt	Roller conveyor	Compressor	Small fan	Pump	Hydraulic pump
Starting parameters						
• Voltage ramp and current limiting						
- Starting voltage %	70	60	50	30	30	30
- Starting time s	10	10	10	10	10	10
- Current limit value	Deactivated	Deactivated	$4 \times I_M$	$4 \times I_M$	Deactivated	Deactivated
• Torque ramp						
- Starting torque	60	50	40	20	10	10
- End torque	150	150	150	150	150	150
- Starting time	10	10	10	10	10	10
• Breakaway pulse	Deactivated (0 ms)	Deactivated (0 ms)	Deactivated (0 ms)	Deactivated (0 ms)	Deactivated (0 ms)	Deactivated (0 ms)
Ramp-down mode	Smooth ramp-down	Smooth ramp-down	Free ramp-down	Free ramp-down	Pump ramp-down	Free ramp-down

Application examples for heavy starting (Class 20)

Heavy starting Class 20 (up to 40 s with 350 % $I_{n \text{ motor}}$).

The soft starter has to be selected one performance class higher than the motor used

Application	Stirrer	Centrifuge	Milling machine
Starting parameters			
• Voltage ramp and current limiting			
- Starting voltage %	30	30	30
- Starting time s	30	30	30
- Current limit value	$4 \times I_M$	$4 \times I_M$	$4 \times I_M$
• Torque ramp			
- Starting torque	30	30	30
- End torque	150	150	150
- Starting time	30	30	30
• Breakaway pulse	Deactivated (0 ms)	Deactivated (0 ms)	Deactivated (0 ms)
Ramp-down mode	Free ramp-down	Free ramp-down	Free ramp-down or DC braking

Application examples for very heavy starting (Class 30)

Very heavy starting Class 30 (up to 60 s with 350 % $I_{n \text{ motor}}$).

The soft starter has to be selected two performance classes higher than the motor used

Application	Large fan	Mill	Breaker	Circular saw/bandsaw
Starting parameters				
• Voltage ramp and current limiting				
- Starting voltage %	30	50	50	30
- Starting time s	60	60	60	60
- Current limit value	$4 \times I_M$	$4 \times I_M$	$4 \times I_M$	$4 \times I_M$
• Torque ramp				
- Starting torque	20	50	50	20
- End torque	150	150	150	150
- Starting time	60	60	60	60
• Breakaway pulse	Deactivated (0 ms)	80 %, 300 ms	80 %, 300 ms	Deactivated (0 ms)
Ramp-down mode	Free ramp-down	Free ramp-down	Free ramp-down	Free ramp-down

Note:

These tables present sample set values and device sizes. They are intended only for the purposes of information and are not binding. The set values depend on the application in question and must be optimized during commissioning.

The soft starter dimensions should be checked where necessary with the Win-Soft Starter software or with the help of Technical Assistance.

For Operation in the Control Cabinet

3RW Soft Starters

3RW44 for high-feature applications

Circuit concept

The SIRIUS 3RW44 soft starters can be operated in two different types of circuit.

- **Inline circuit**
The controls for isolating and protecting the motor are simply connected in series with the soft starter. The motor is connected to the soft starter with three cables.
- **Inside-delta circuit**
The wiring is similar to that of wye-delta starters. The phases of the soft starter are connected in series with the individual motor windings. The soft starter then only has to carry the phase current, amounting to about 58 % of the rated motor current (conductor current).

Comparison of the types of circuit

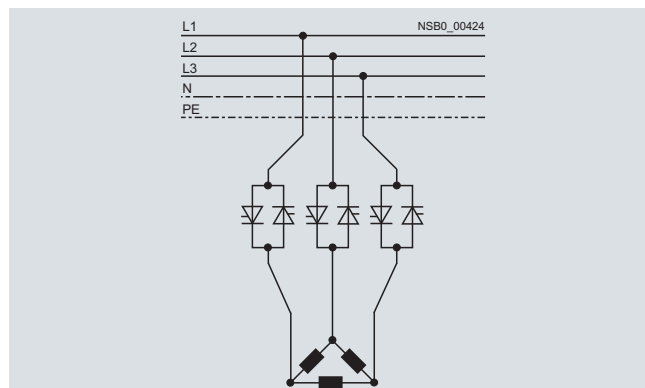

Inline circuit:

Rated current I_b corresponds to the rated motor current I_n , 3 cables to the motor

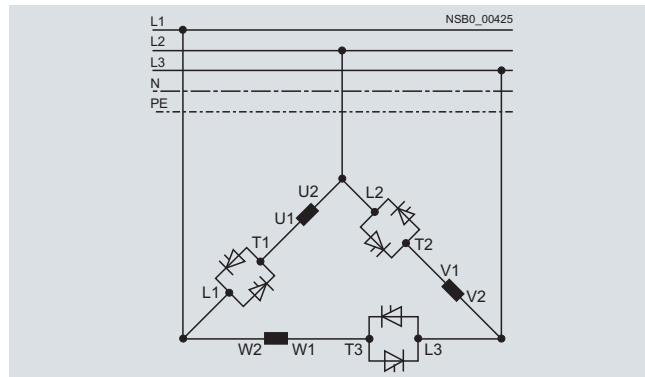

Inside-delta circuit:

Rated current I_b corresponds to approx. 58 % of the rated motor current I_n , 6 cables to the motor (as with wye-delta starters)

Which circuit?

Using the inline circuit involves the lowest wiring outlay. If the soft starter to motor connections are long, this circuit is preferable. With the inside-delta circuit there is double the wiring complexity but a smaller size of device can be used at the same rating.

Thanks to the choice of operating mode between the inline circuit and inside-delta circuit, it is always possible to select the most favorable solution.

The braking function is possible only in the inline circuit.

Configuration

The 3RW44 solid-state soft starters are designed for normal starting. In case of heavy starting or increased starting frequency, a larger device must be selected.

For long starting times it is recommended to have a PTC sensor in the motor. This also applies for the ramp-down modes smooth ramp-down, pump ramp-down and DC braking, because during the ramp-down time in these modes, an additional current loading applies in contrast to free ramp-down.

In the motor feeder between the SIRIUS 3RW soft starter and the motor, no capacitive elements are permitted (e. g. no reactive-power compensation equipment). In addition, neither static systems for reactive-power compensation nor dynamic PFC (Power Factor Correction) must be operated in parallel during starting and ramp-down of the soft starter. This is important to prevent faults arising on the compensation equipment and/or the soft starter.

All elements of the main circuit (such as fuses and controls) should be dimensioned for direct starting, following the local short-circuit conditions. Fuses, controls and overload relays must be ordered separately.

A bypass contact system and solid-state overload relay are already integrated in the 3RW44 soft starter and therefore do not have to be ordered separately.

The harmonic component load for starting currents must be taken into consideration for the selection of motor starter protectors (selection of release).

Note:

When induction motors are switched on, voltage drops occur as a rule on starters of all types (direct starters, wye-delta starters, soft starters). The infeed transformer must always be dimensioned such that the voltage dip when starting the motor remains within the permissible tolerance. If the infeed transformer is dimensioned with only a small margin, it is best for the control voltage to be supplied from a separate circuit (independently of the main voltage) in order to avoid the potential switching off of the soft starter.

Device interface, PROFIBUS DP communication module, Soft Starter ES parameterizing and operating software

The 3RW44 electronic soft starters have a PC interface for communicating with the Soft Starter ES software or for connecting the external display and operator module. If the optional PROFIBUS communication module is used, the 3RW44 soft starter can be integrated in the PROFIBUS network and communicate using the GSD file or Soft Starter ES Premium software.

The Soft Starter ES parameterizing and operating software can be downloaded from

<http://www.siemens.com/softstarter> > Software with a 14-day trial license.

More information about Soft Starter ES can be found in Chapter 12 of Catalog LV 1.

For Operation in the Control Cabinet

3RW Soft Starters

3RW44 for high-feature applications

Manual for SIRIUS 3RW44

Besides containing all important information on configuring, commissioning and servicing, the manual also contains example circuits and the technical specifications for all devices.

Win-Soft Starter selection and simulation program

With this software, you can simulate and select all Siemens soft starters, taking into account various parameters such as mains properties, motor and load data, and special application requirements.

The software is a valuable tool, which makes complicated, lengthy manual calculations for determining the required soft starters superfluous.

The Win-Soft Starter selection and simulation program can be downloaded from:

<http://www.siemens.com/softstarter> > Software

More information can be found on the Internet at:

<http://www.siemens.com/softstarter>

SIRIUS soft starter training course (SD-SIRIUSO)

Siemens offers a 2-day training course on the SIRIUS solid-state soft starters to keep customers and own personnel up-to-date on configuring, commissioning and servicing issues.

Please direct enquiries and applications to:

Siemens AG
Training Center for Automation and Industrial Solution
Gleiwitzer Strasse 555
90475 Nürnberg
GERMANY
Tel.: +49 (0) 911 895 3202
Fax: +49 (0) 911 895 3275
E-mail: ingeborg.hoier@siemens.com
<http://www.siemens.com/sitrain-cd>

For Operation in the Control Cabinet

3RW Soft Starters

Project planning aids

Dimensional drawings

3RW30 for standard applications

3RW30 1. ... 3RW30 4.

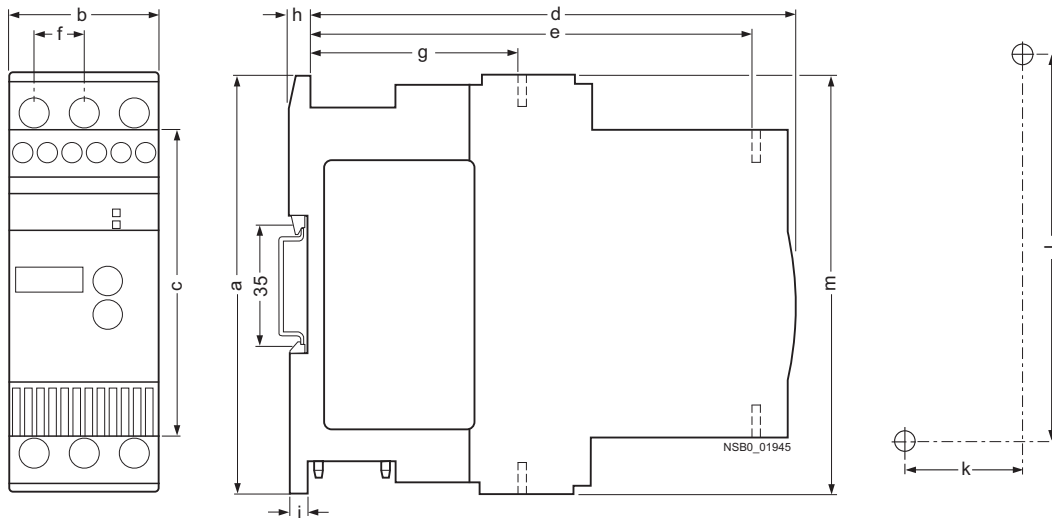

Type/Dimension (mm)	a	b	c	d	e	f	g	h	i	k	l	m
3RW30 1.-1.	95	45	62	146	126	14.4	63	5	6.5	35	85	95
3RW30 1.-2.	95	45	62	146	126	14.4	63	5	6.5	35	85	117.2
3RW30 2.-1.	125	45	92	146	126	14.4	63	5	6.5	35	115	125
3RW30 2.-2.	125	45	92	146	126	14.4	63	5	6.5	35	115	150
3RW30 3.	160	55	110	163	140	18	63	5	6.5	30	150	144
3RW30 4.	170	70	110	181	158	22.5	85	5	10	60	160	160

Clearances to grounded parts (mm)	Lateral	Top	Bottom	Fixing screws	Tightening torques (Nm)
3RW30 1.	5	60	40	M4	1
3RW30 2.	5	60	40	M4	1
3RW30 3.	30	60	40	M4	1
3RW30 4.	30	60	40	M4	2

3RW30 03-1. (screw terminals)

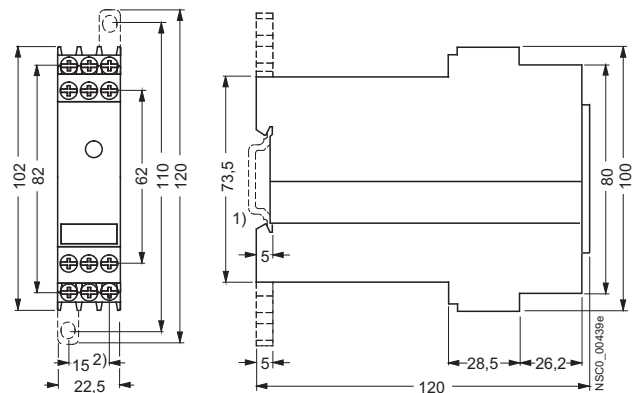

3RW30 03-2. (spring-type terminals)

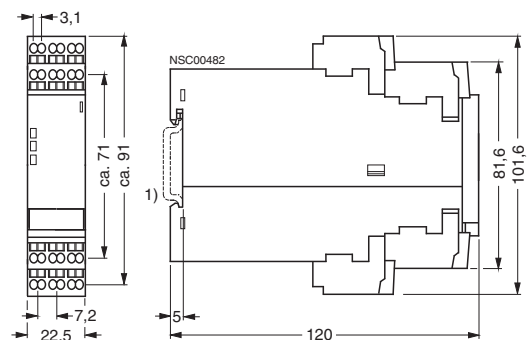

1) For mounting onto standard mounting rail TH 35 according to EN 60715.

2) Dimension for screw fixing.
Screw fixing with two 3RP1 903 push-in lugs per 3RW30 03 device.

3RW40 for standard applications

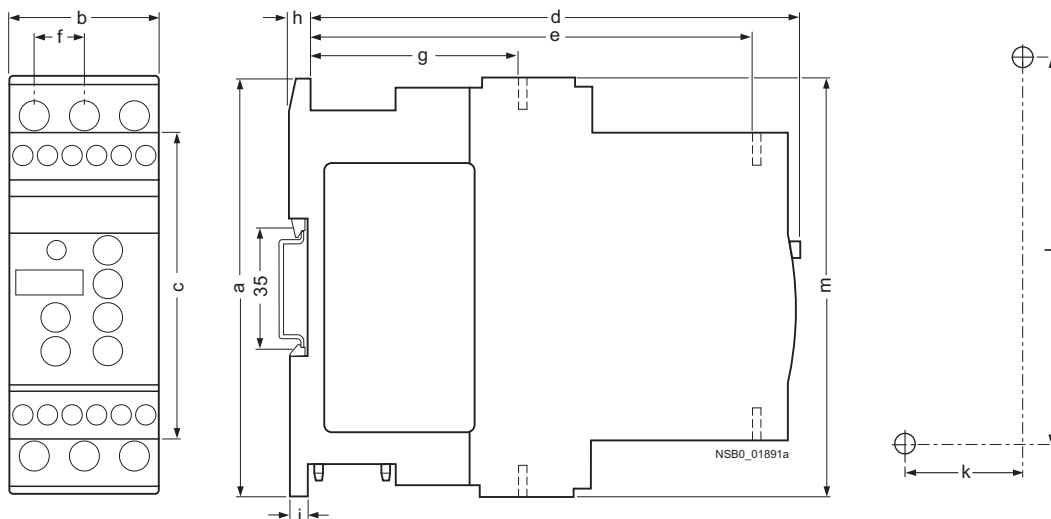

Type/Dimension (mm)	a	b	c	d	e	f	g	h	i	k	l	m
3RW40 2.-1.	125	45	92	149	126	14.4	63	5	6.5	35	115	125
3RW40 2.-2.	125	45	92	149	126	14.4	63	5	6.5	35	115	150
3RW40 3.	170	55	110	165	140	18	63	5	6.5	30	150	144
3RW40 4.	170	70	110	183	158	22.5	85	5	10	60	160	160

Clearances to grounded parts (mm)	Lateral	Top	Bottom	Fixing screws	Tightening torques (Nm)
3RW40 2.	5	60	40	M4	1
3RW40 3.	30	60	40	M4	1
3RW40 4.	30	60	40	M4	2

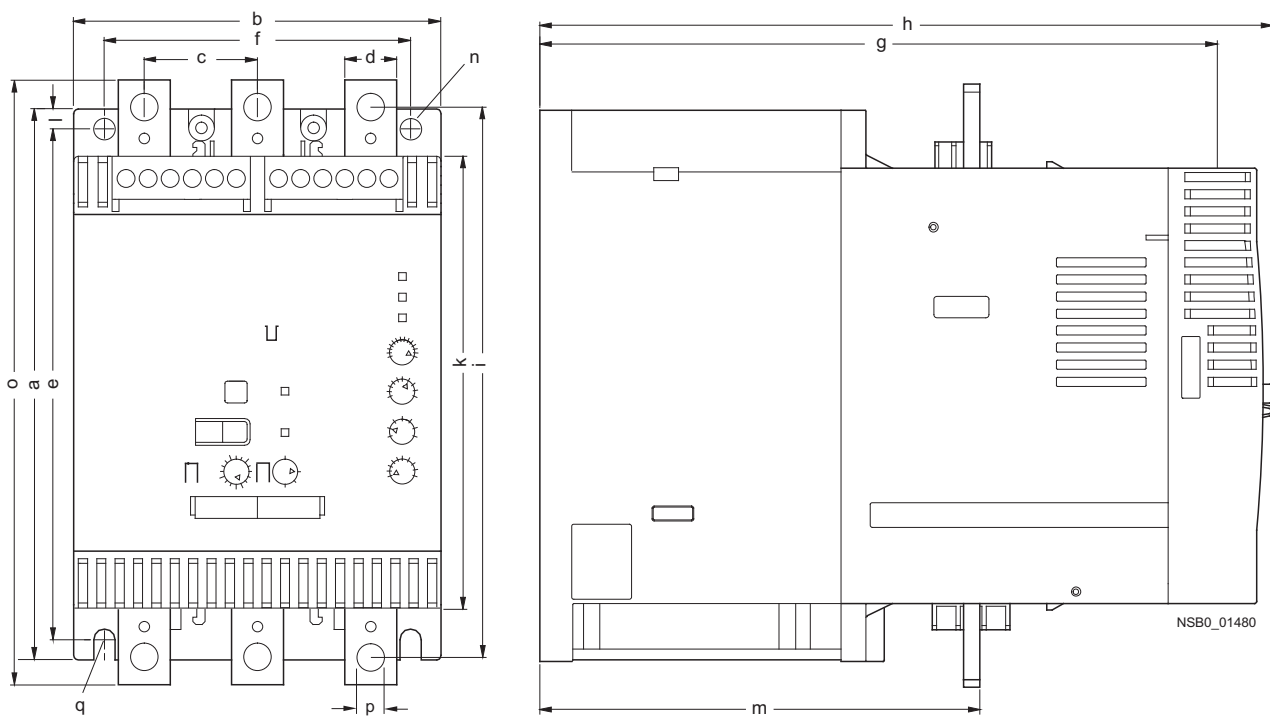

Type/Dimension (mm)	a	b	c	d	e	f	g	h	i	k	l	m	n	o	p	q
3RW40 5.	180	120	37	17	167	100	223	250	180	148	6.5	153	7	198	9	M6, 10 Nm
3RW40 7.	210	160	48	25	190	140	240	278	205	166	10	166	9	230	11	M8, 15 Nm

For Operation in the Control Cabinet

3RW Soft Starters

Project planning aids

3RW44 2., 3RW44 3. and 3RW44 4. for High-Feature applications

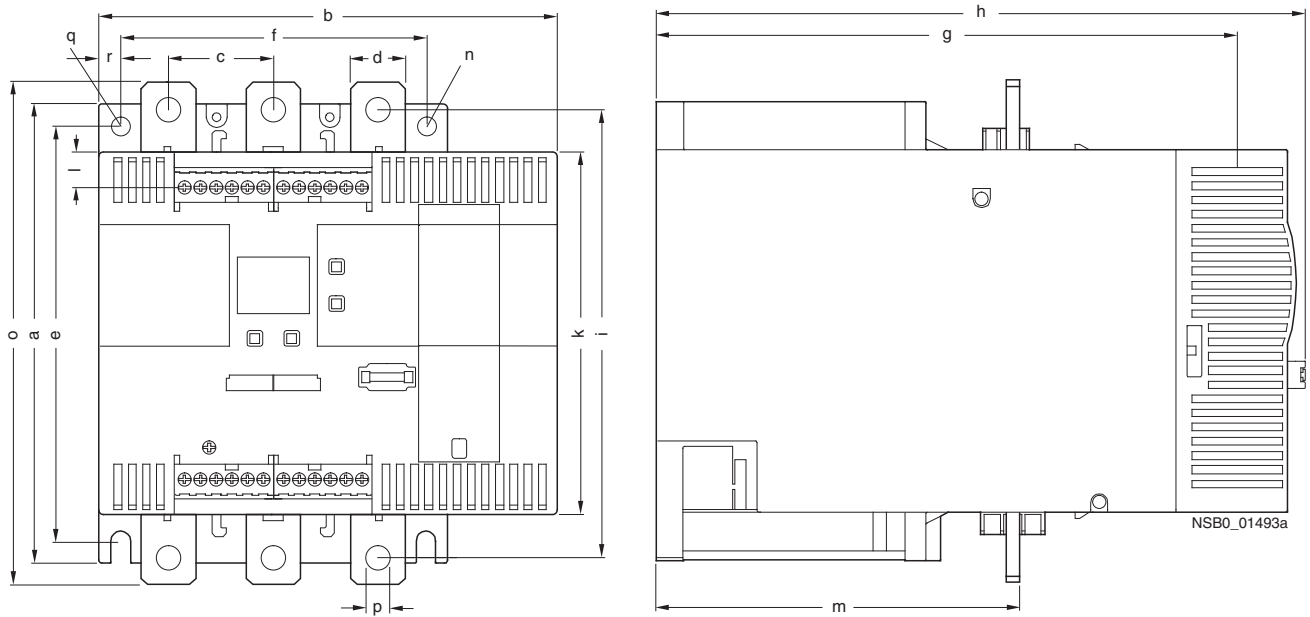

Type/Dimension (mm)	a	b	c	d	e	f	g	h	i	k	l	m	n	o	p	q	r
3RW44 2.	180	170	37	11	167	100	240	270	174	148	7.5	153	7	184	6.6	M6, 10 Nm	10
3RW44 3.	180	170	37	17	167	100	240	270	174	148	7.5	153	7	198	9	M6, 10 Nm	10
3RW44 4.	210	210	48	25	190	140	269	298	205	166	16	166	9	230	11	M8, 15 Nm	10

For Operation in the Control Cabinet

3RW Soft Starters

Project planning aids

3RW44 5. and 3RW44 6. for High-Feature applications

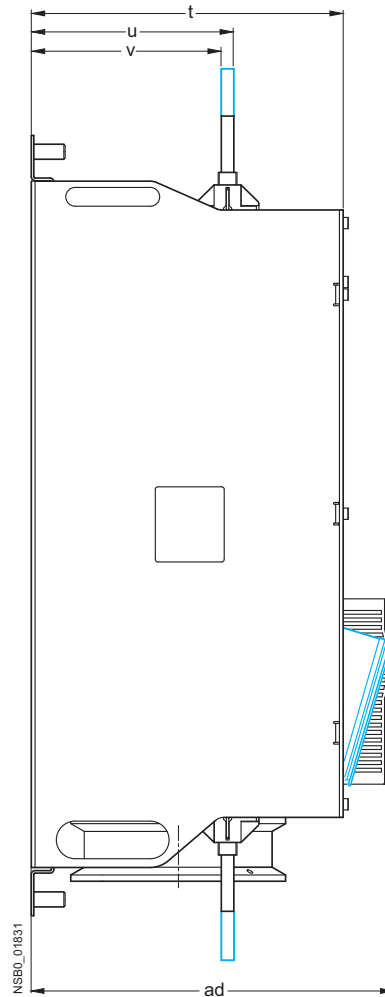
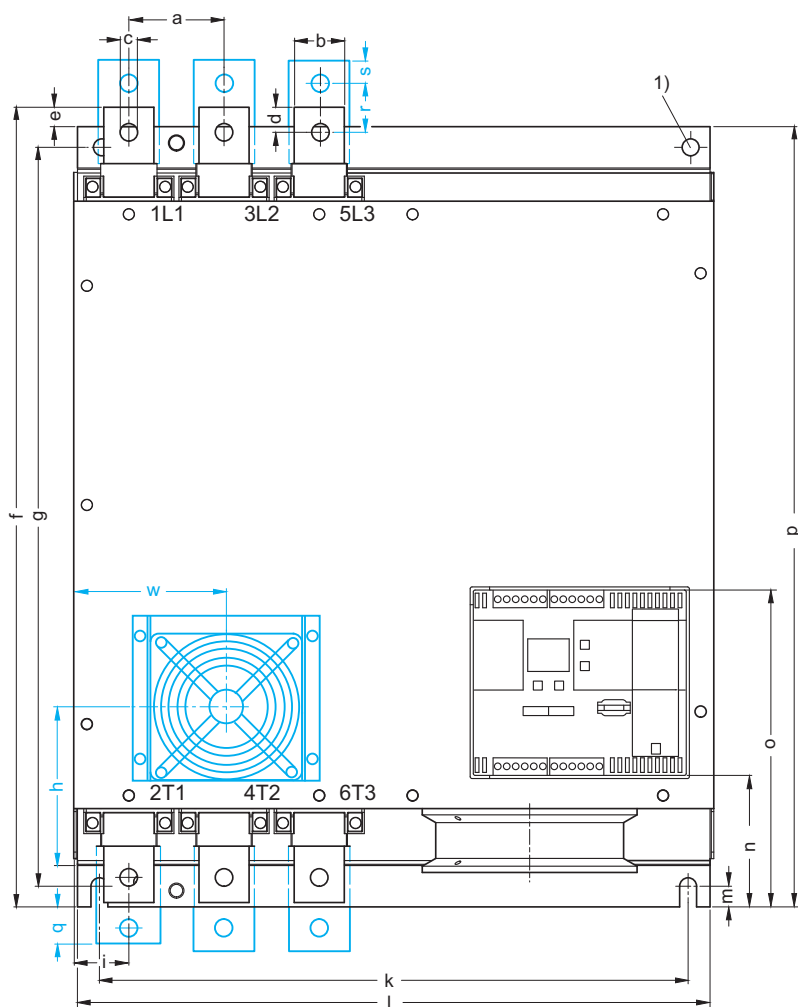

1) For M12 screw, tightening torque max. 35 Nm (310 lb.in).

Type/Dimension (mm)	a	b	c	d	e	f	g	h	i	k	l	m
3RW44 5.	76	40	14	20	15.5	638.5	590	--	44	470	510	16.5
3RW44 6.	85	50	14	--	--	667	660	160	37.5	535	576	16.5

Type/Dimension (mm)	n	o	p	q	r	s	t	u	v	w	ad
3RW44 5.	105	253	623	--	--	--	249	162	152	--	290
3RW44 6.	103	251	693	43.5	40	20	249	162	151.4	123	290

3RW49 00-0AC00 external display and operator module

Installation cutout for 3RW49 00-0AC00 external display and operator module

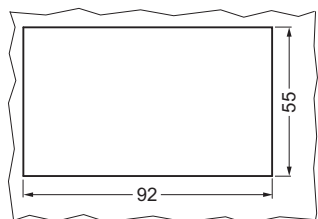
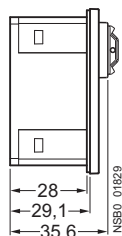
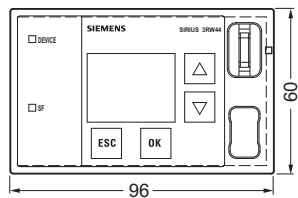

For Operation in the Control Cabinet

3RW Soft Starters

Project planning aids

Schematics

3RW30 .. connection examples for control circuit

Control using switches

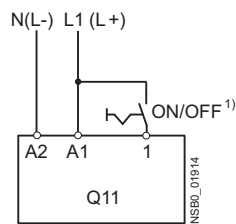

Automatic mode

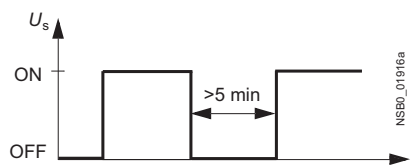
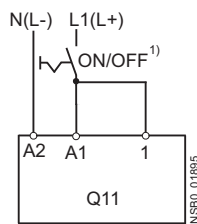

Control by pushbutton

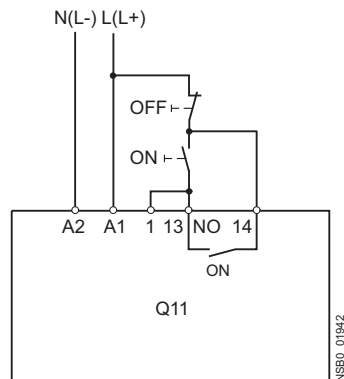

Control of a main contactor

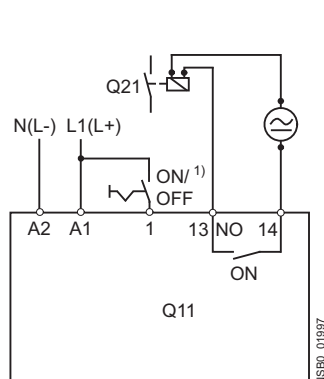

3RW30 connection examples for main circuit²⁾

3RW30 – 3-phase motor with 3NA/3NE fuse

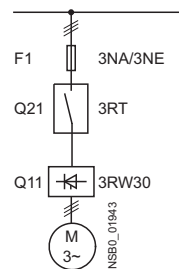

3RV motor starter protector

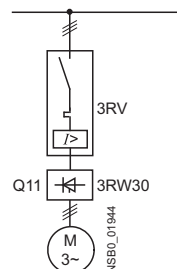

1) Caution: Risk of restarting!

When operating with a switch (ON/OFF) a new, automatic restart will take place automatically if the start command is still active at terminal 1.

2) As an alternative, the motor feeder can also be installed as a fuseless or as a fused version. For fuse and switching device coordination, see "Technical specifications".

The wiring diagrams are provided only as examples.

6

3RW40 2. ... 3RW40 4. connection examples for control circuit

Control using switches

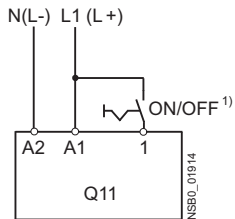

Automatic mode

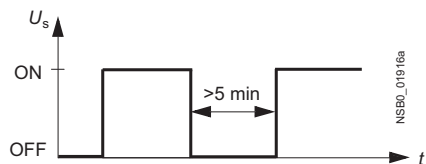
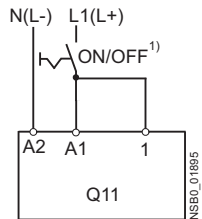

Control with remote reset

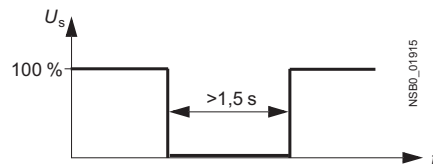
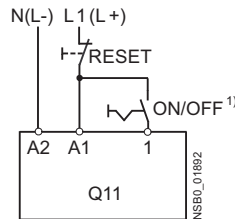

Control of 3RW40 2. ... 3RW40 4. by pushbutton

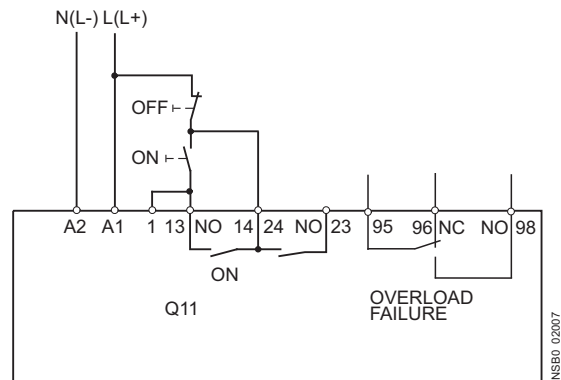

Control of a main contactor

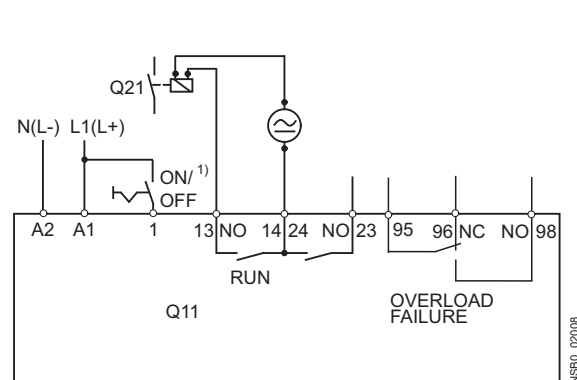

Connection example of 3RW40 2. ... 3RW40 4. for PTC sensors (thermistor motor protection)

Thermoclick

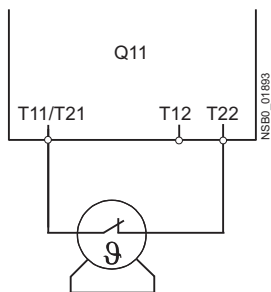

PTC type A

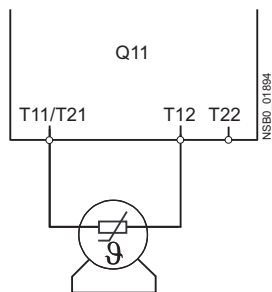

1) Caution: Risk of restarting!

When operating with a switch (ON/OFF) a new, automatic restart will take place automatically if the start command is still active at terminal 1.

For Operation in the Control Cabinet

3RW Soft Starters

Project planning aids

3RW40 5. and 3RW40 7. connection examples for control circuit

Control by switch using internal 24 V DC supply

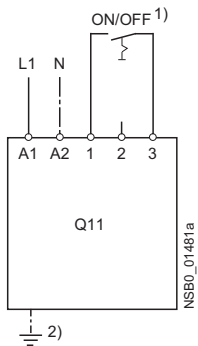

external power supply

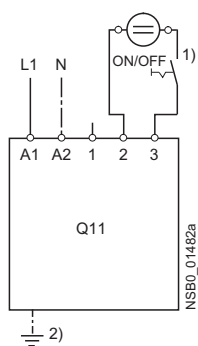

Control by pushbutton

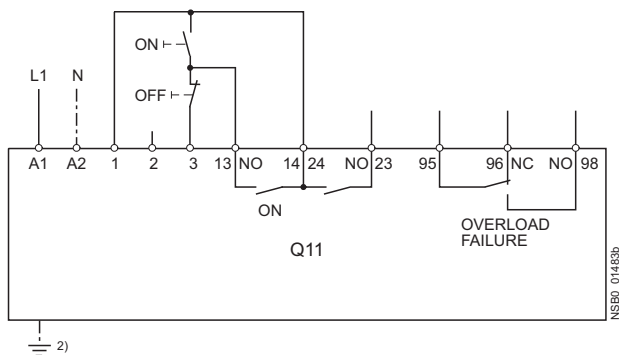

Control of a main contactor

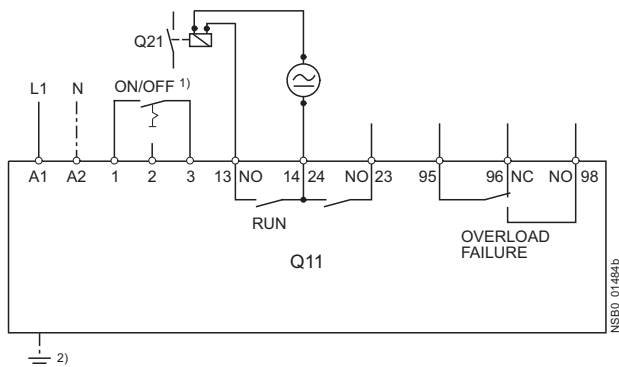

3RW40 connection examples for main circuit³⁾

3RW40 – 3-phase motor with 3NA/3NE fuse

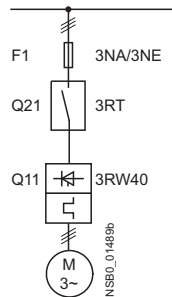

3RV motor starter protector/3VL circuit breaker

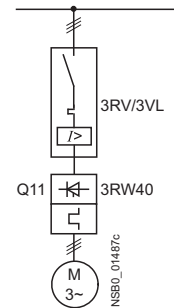

1) Caution: Risk of restarting!

When operating with a switch (ON/OFF) a new, automatic restart will take place automatically if the start command is still active at terminal 3.

2) Grounding necessary for fan connection to 3RW40 5...

3) As an alternative, the motor feeder can also be installed as a fuseless or as a fused version. For fuse and switching device coordination, see "Technical specifications".

The wiring diagrams are provided only as examples.

6

For Operation in the Control Cabinet

3RW Soft Starters

Project planning aids

3RW44 connection examples for main and control circuits

Main circuit

Possibility 1a:
Inline circuit with motor starter protector and SITOR fuse (semiconductor protection only)

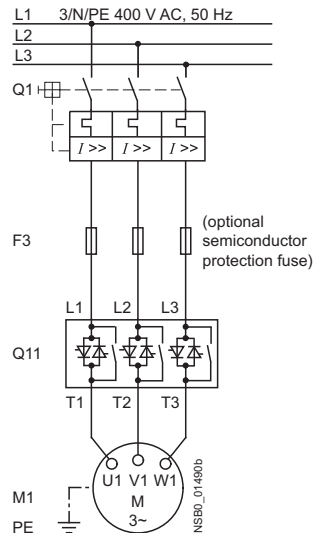

Control circuit

Possibility 1:
Control by pushbutton

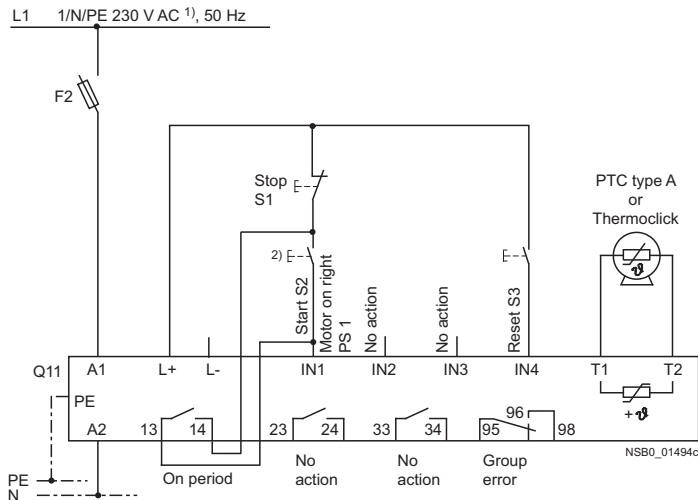

Main circuit

Possibility 1b:
Inline circuit with all-range protection (line and semiconductor protection) (line and semiconductor protection only)

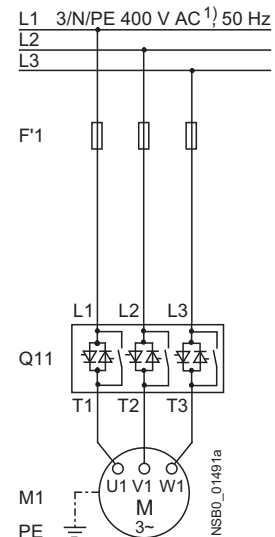

Possibility 1c:
Inline circuit with line and SITOR fuse (semiconductor protection only)

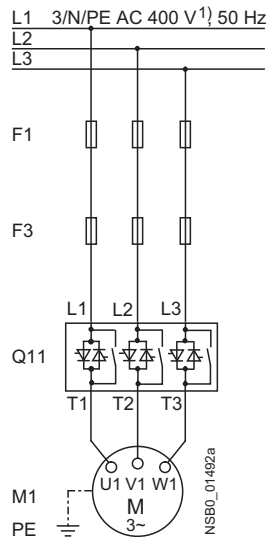

1) Permissible values for main and control voltage, see "Technical specifications".

2) **Caution: Risk of restarting!**

Because the output is parameterized to "Motor ON", the start command is automatically active after the reset command and a new, automatic restart will take place. This applies especially in case of motor protection tripping. For safety reasons we recommend connecting the group error output (terminals 95/96) in series with the output parameterized to "Motor ON".

For Operation in the Control Cabinet

3RW Soft Starters

Project planning aids

Main circuit

Possibility 2:
In-line circuit with main contactor

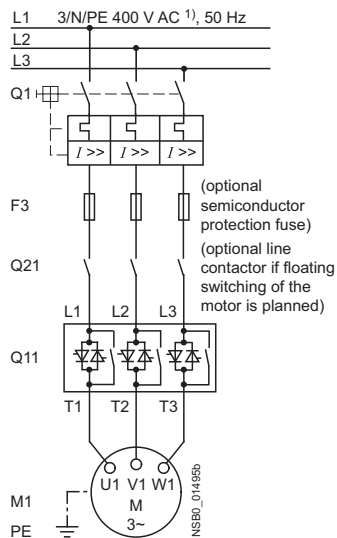

Control circuit

Possibility 2:
Control of a main contactor and control by means of PLC

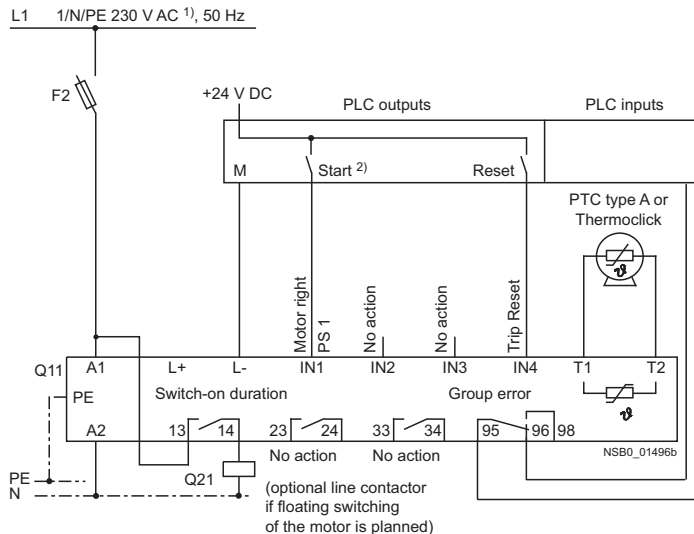

1) Permissible values for main and control voltage, see "Technical specifications".

- 2) **Caution: Risk of restarting!**
The start command (e. g. from the PLC) must be reset prior to a reset command because a new, automatic restart will take place automatically if a start command is active after the reset command. This applies especially in case of motor protection tripping.
For safety reasons we recommend incorporating the group error output (terminals 95 and 96) in the controller.

For Operation in the Control Cabinet

3RW Soft Starters

Project planning aids

Main circuit

Possibility 3a:
 Inline circuit with ramp-down function DC braking³⁾
 (for device types 3RW44 22 to 3RW44 25)

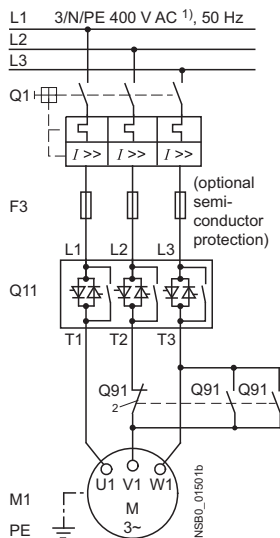

Control circuit

Possibility 3a:
 Control of the DC braking contactor³⁾

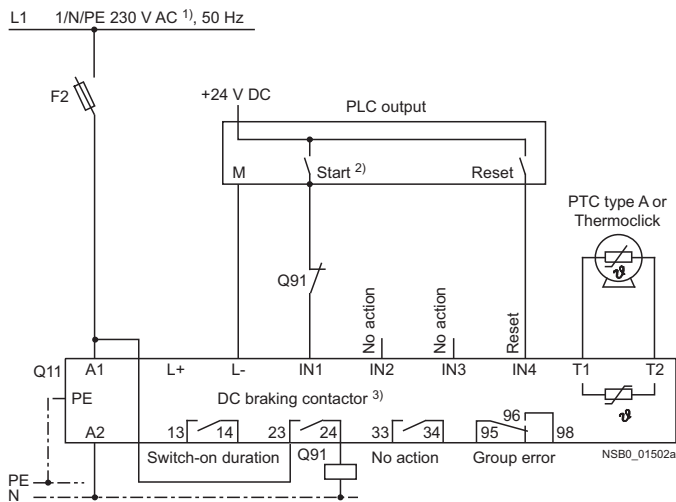

Main circuit

Possibility 3b:
 Inline circuit with ramp-down function DC braking³⁾
 (for device types 3RW44 26 to 3RW44 47)

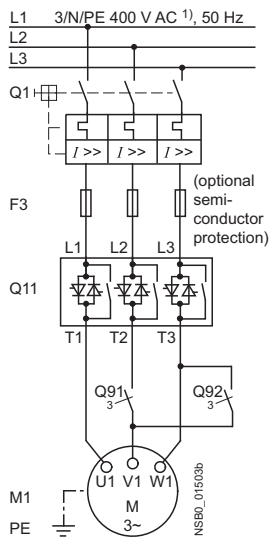

Control circuit

Possibility 3b:
 Control of the DC braking contactor³⁾

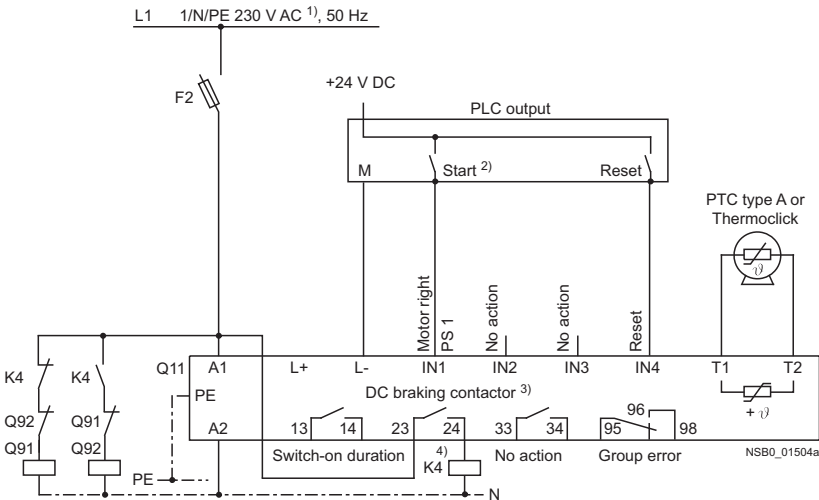

¹⁾ Permissible values for main and control voltage, see "Technical specifications".

²⁾ **Caution: Risk of restarting!**

The start command (e. g. from the PLC) must be reset prior to a reset command because a new, automatic restart will take place automatically if a start command is active after the reset command. This applies especially in case of motor protection tripping. For safety reasons we recommend incorporating the group error output (terminals 95 and 96) in the controller.

³⁾ If the ramp-down function "Combined braking" is selected, no braking contactor is required.

If the ramp-down function "DC braking" is selected, a braking contactor must be used in addition. For type see "Fuse Assignment (Inline Circuit)" on pages 6/44 to 6/46.

For applications with large centrifugal masses ($J_{Load} > J_{Motor}$) we recommend the function "DC braking". The output 2 must be switched over to "DC braking contactor".

⁴⁾ Auxiliary relay K4, e. g.:

LZX:RT4A4T30 (230 V AC rated control supply voltage),
 LZX:RT4A4S15 (115 V AC rated control supply voltage).

For Operation in the Control Cabinet

3RW Soft Starters

Project planning aids

Main circuit

Possibility 4a:
Inside-delta circuit

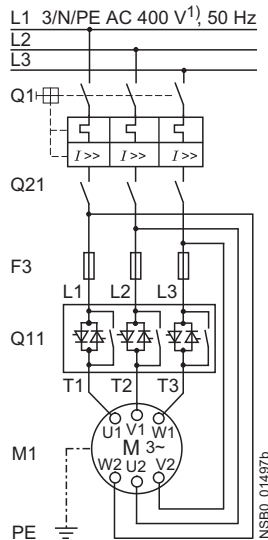

Possibility 4b:
Change of direction of rotation for
inside-delta circuit

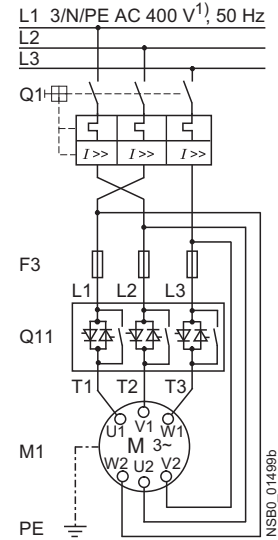

Control circuit

Possibility 4:
Control by means of PLC

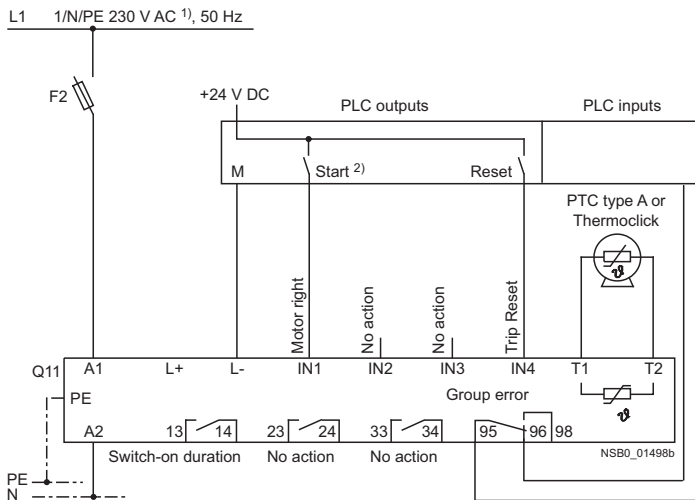

1) Permissible values for main and control voltage, see "Technical specifications".

- 2) **Caution: Risk of restarting!**
The start command (e. g. from the PLC) must be reset prior to a reset command because a new, automatic restart will take place automatically if a start command is active after the reset command. This applies especially in case of motor protection tripping.
For safety reasons we recommend incorporating the group error output (terminals 95 and 96) in the controller.

For Operation in the Control Cabinet

3RA1 Fuseless Load Feeders

General data

Overview

3RA1 fuseless load feeders

The 3RA1 fuseless load feeders consist of the 3RV1 motor starter protector and the 3RT1 contactor. Motor starter protectors and contactors are electrically and mechanically connected using pre-assembled assembly kits (link modules, wiring kits and standard mounting rail or busbar adapters).

As the 3RA1 fuseless load feeders are constructed from 3RV1 motor starter protectors and 3RT1 contactors, the same accessories can be used for the 3RA fuseless load feeders as for these motor starter protectors and contactors.

Pre-assembled assembly kits are available as accessories for the power spectrum up to 45 kW. The desired fuseless load feeder can thus be assembled quickly and economically by the customer. A time saving is also achieved in connection with switchgear acceptances, as – unlike with conventional wiring systems – there is no need to rectify possible wiring errors.

The 3RV1 motor starter protector is responsible for overload and short-circuit protection in the fuseless load feeder. Back-up protective devices, such as melting fuses or limiters, are superfluous here, as the motor starter protector is capable of withstanding short-circuits of up to 50 or 100 kA at 400 V.

The 3RT1 contactor is particularly suitable for extremely complex switching tasks requiring the greatest endurance.

The permissible ambient temperature is 60 °C with butt-mounting and without derating (70 °C possible subject to certain restrictions).

3RA1 fuseless load feeders are available for motors up to 45 kW at AC-3 and 400 V (grounded network) and setting ranges from 0.14 A to 100 A.

3RA1 fuseless load feeders are supplied in four different sizes:

Size	Width mm	Max. rated current I_n max A	For induction motors up to kW
S00	45	12	5.5
S0	45	25	11
S2	55	50	22
S3	70	100	45

The SENTRON 3VL circuit breakers and the SIRIUS 3RT contactors can be used for fuseless load feeders >100 A. The corresponding clearances from grounded or live parts, as detailed in the technical specifications, must be observed.

Operating conditions

3RA1 load feeders are climate-proof. They are intended for use in enclosed rooms in which no severe operating conditions (such as dust, caustic vapors, hazardous gases) prevail. Suitable covers must be provided for installation in dusty and damp locations.

Overload tripping times

All 3RA1 fuseless load feeders described here are designed for normal starting, in other words for overload tripping times of less than 10 s (CLASS 10). At rated-load operating temperature the tripping times are shorter, depending on the particular equipment and the setting range. The exact values can be derived from the tripping characteristics of the motor starter protectors.

Types of coordination

EN 60947-4-1 and IEC 60947-4-1 make a distinction between two different types of coordination, which are designated type of coordination "1" and type of coordination "2". Any short-circuits that occur are cleared safely by both types of coordination. The only differences concern the extent of the damage caused to the device by a short-circuit.

T_{OC}
1

Type of coordination "1"

The fuseless load feeder may be non-operational after a short-circuit has been cleared. Damage to the contactor or to the overload release is permissible. For 3RA1 load feeders, the motor starter protector itself always achieves type of coordination "2".

T_{OC}
2

Type of coordination "2"

There must be no damage to the overload release or to any other components after a short-circuit has been cleared. The 3RA1 fuseless load feeder can resume operation without needing to be renewed. At most, welding of the contactor contacts is permissible if they can be disconnected easily without any significant deformation.

These types of coordination are indicated in the Technical specifications by orange backgrounds.

For Operation in the Control Cabinet

3RA1 Fuseless Load Feeders

General data

Design

Complete units

The 3RA1 fuseless load feeders can be ordered as complete units for direct start or for reversing duty. Control supply voltages of AC 50 Hz 230 V or 24 V DC and assembly on a 35 mm standard mounting rail or in a 40 or 60 mm busbar system are possible.

Single devices for self-assembly can be ordered if other rated control supply voltages are required. The assembly kits simplify customer assembly of the load feeders.

The corresponding clearances from grounded or live parts, as detailed in the technical specifications, must be observed.

Customer assembly

The standard devices can be combined optimally – in terms of both technical specifications and dimensions, thanks to the modular system of the SIRIUS series.

The fuseless load feeders can thus be assembled easily by the customer. It is simply necessary to assemble the standard 3RV1 motor starter protector and 3RT1 contactor and the appropriate assembly kit together.

For the order numbers for single devices and assembly kits, see the selection and ordering data "3RA11 Direct-On-Line Starters and 3RA12 Reversing Starters for Standard Mounting Rail, Screw Fixing or Busbar Systems".

For assembly kits for direct start or reversing duty for mounting on standard mounting rails or busbars, see ordering data "Accessories for Direct-On-Line Starters and Reversing Starters".

If a motor starter protector with a rotary operating mechanism is required for the lower setting ranges up to 12 A, the S0 motor starter protector can also be assembled with an S00 contactor. A special link module is available for this purpose.

For the installation of feeders, it is imperative to use standard mounting rail adapters, as from size S2 for direct start and as from size S0 for reversing duty, to ensure the necessary mechanical strength. A standard mounting rail adapter is not necessary if a busbar adapter is used.

Accessories

The accessories for the single devices, such as auxiliary switches and undervoltage trip units, can also be used for the 3RA1 fuseless load feeders.

In addition, certain accessories have been optimized for the fuseless load feeders. They include the top-connected, transverse auxiliary switch on the motor starter protector with one changeover contact or one NO contact + one NC contact. Special auxiliary switch blocks that can be snapped on from below are available for the contactor. These two accessories enable the fuseless load feeders to be wired simply without having to route cables through the device.

The special accessories for 3RA fuseless load feeders take the form of assembly kits for 3RV1 motor starter protectors and 3RT1 contactors.

Mounting

3RA1 fuseless load feeders are available for assembly on TH 35 standard mounting rails according to EN 60715 (depth 15 mm) or on busbar adapters with a busbar center-to-center clearance of 40 or 60 mm and a busbar thickness of 5 or 10 mm with chamfered edges.

The fuseless load feeders are also suitable for screw fixing.

Up to size S0 the 3RA11 fuseless load feeders can also be configured with the 3RV19 infeed system (see 3RV19 Infeed System).

Size S00 and S0 can be screwed on with the aid of push-in lugs (see Accessories for Direct-On-Line and Reversing Starters).

For Operation in the Control Cabinet

3RA1 Fuseless Load Feeders

General data

Direct start • For standard rail mounting • Size S00 and S0

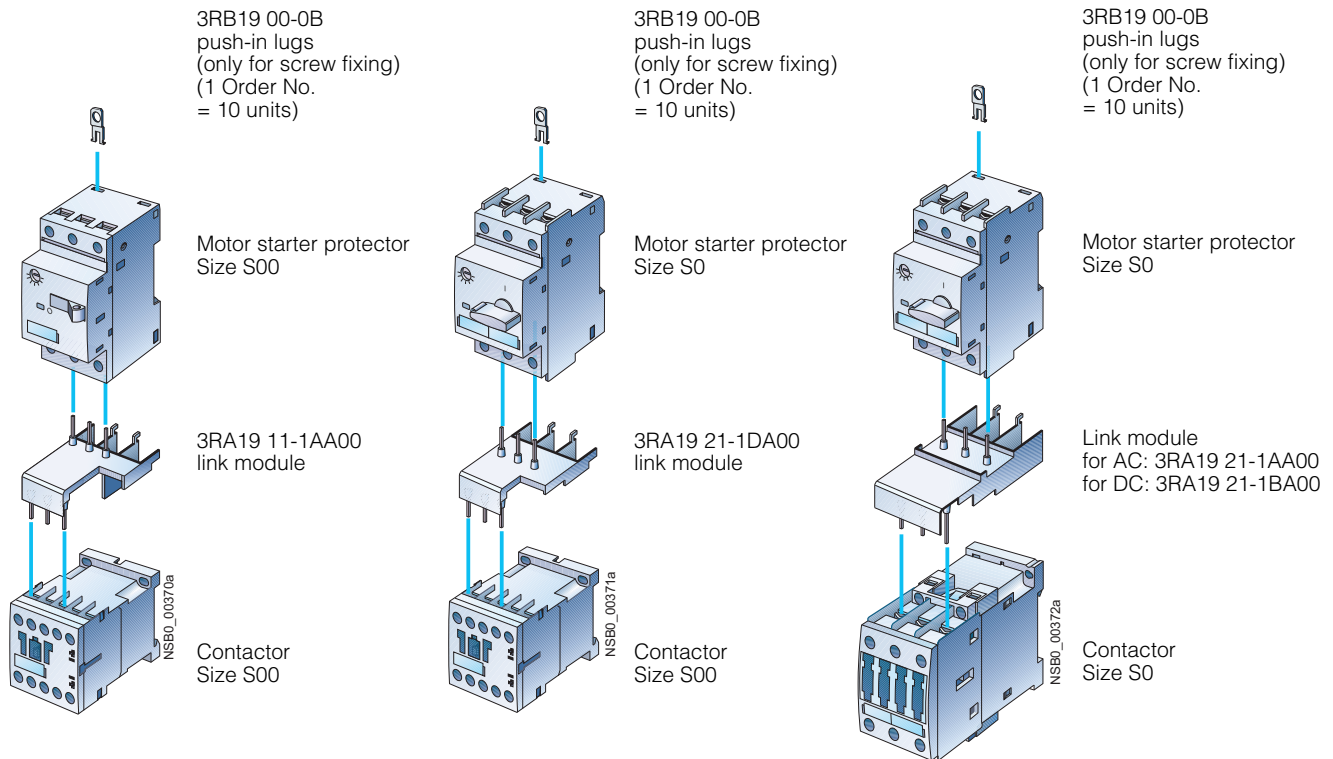

Direct start • For standard rail mounting • Size S2 and S3

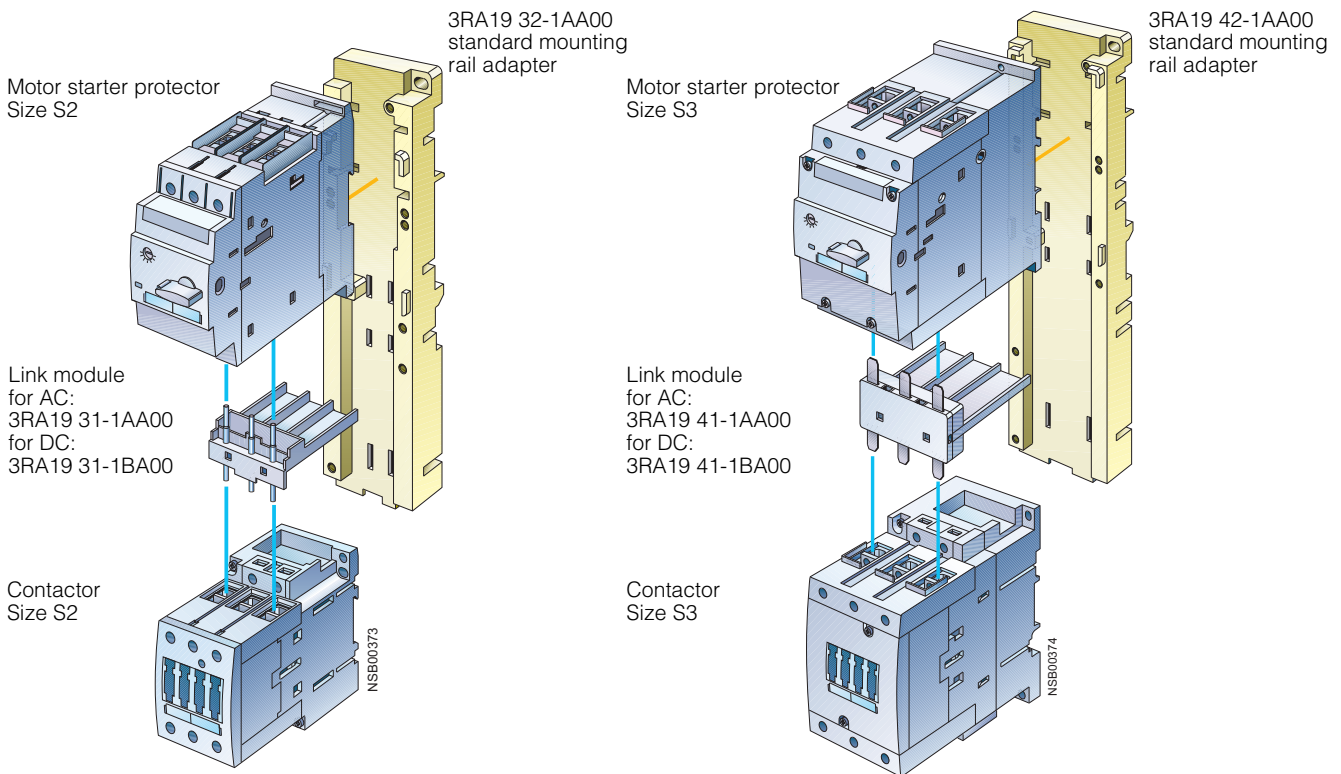

These graphical overviews are shown without small mounting parts (screws etc.).

For Operation in the Control Cabinet

3RA1 Fuseless Load Feeders

General data

Direct start • For 40 mm and 60 mm busbar systems • Size S00 and S0

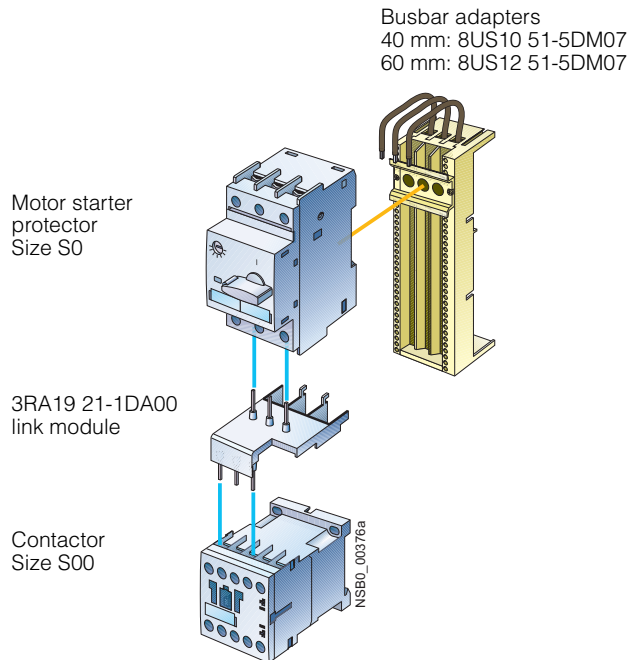
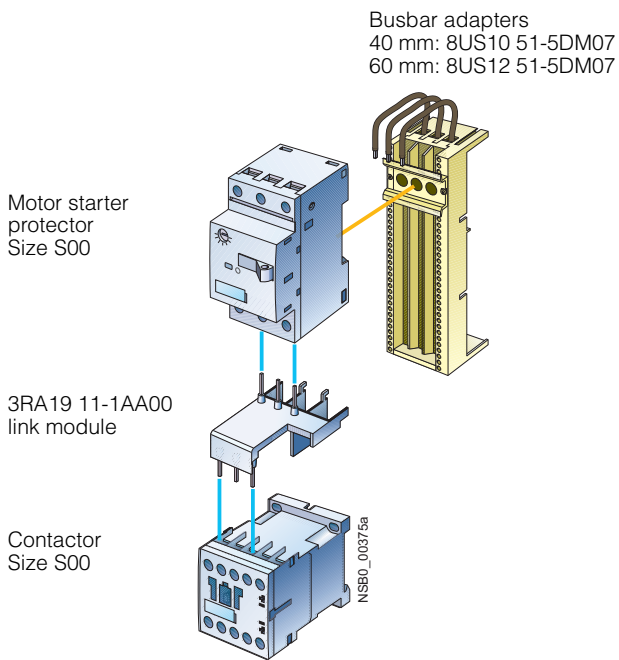

Direct start • For 40 mm and 60 mm busbar systems • Size S0 and S2

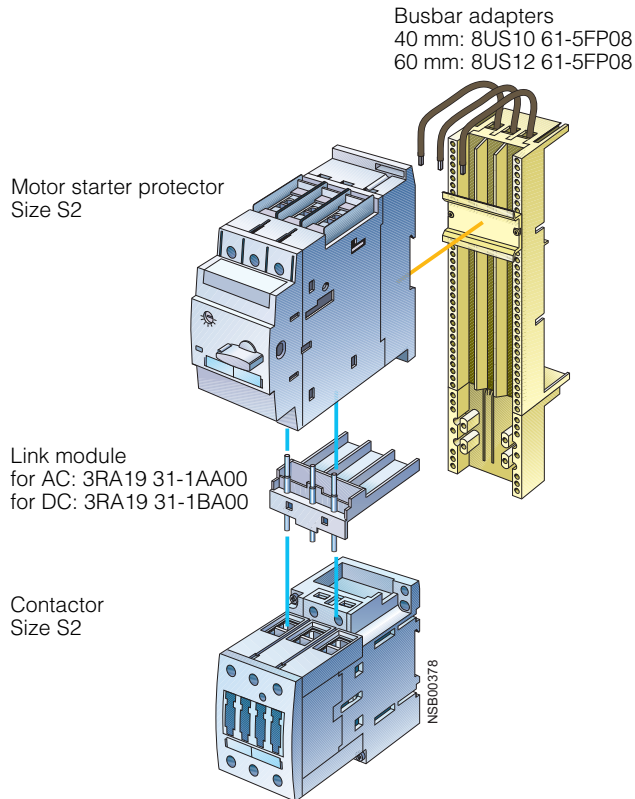
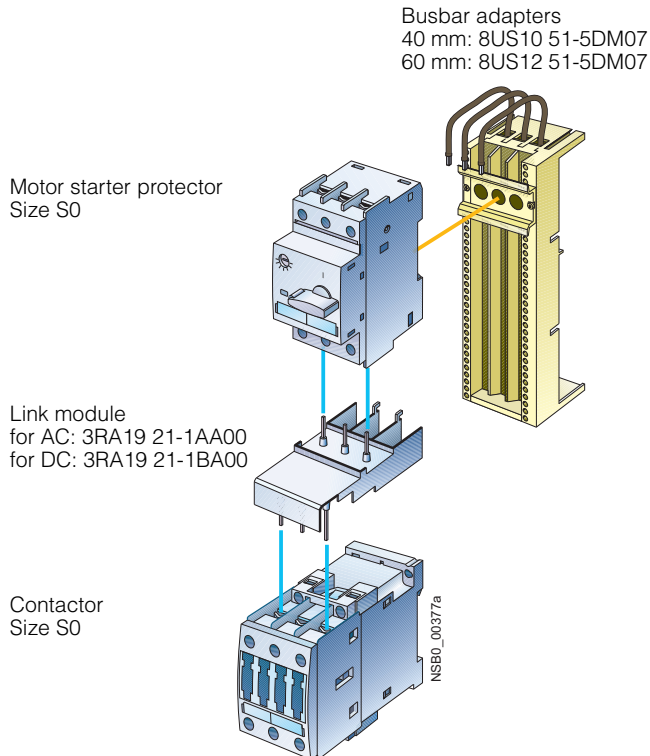

These graphical overviews are shown without small mounting parts (screws etc.).

6

For Operation in the Control Cabinet

3RA1 Fuseless Load Feeders

General data

Reversing duty • For standard rail mounting • Size S00 and S0

3RB19 00-0B
push-in lugs
(only for screw fixing)
(1 Order No.
= 10 units)

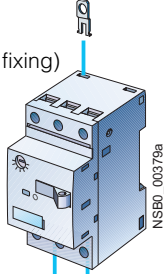

Motor starter
protector
Size S00

3RA19 11-1AA00
link module

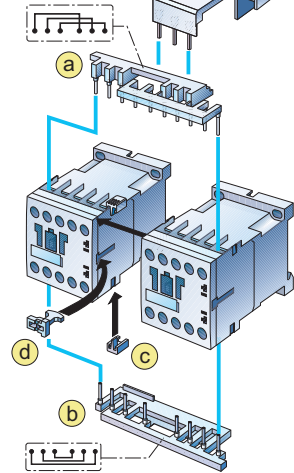
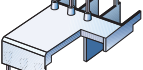

2 contactors
Size S00

3RA19 13-2A
wiring kit

- a Upper wiring module
- b Lower wiring module
- c 2 connecting clips
- d Mechanical interlock (can be removed)

3RB19 00-0B
push-in lugs
(only for screw fixing)
(1 Order No.
= 10 units)

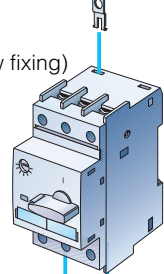

Motor starter
protector
Size S0

3RA19 21-1DA00
link module

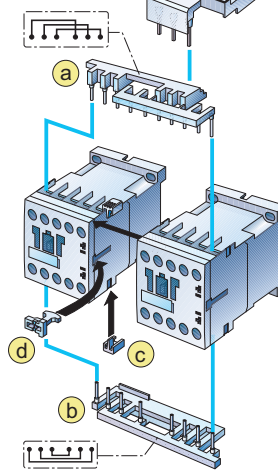
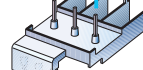

2 contactors
Size S0

Reversing duty • For standard rail mounting • Size S0

3RA19 23-1B
assembly kits (RH)
for reversing duty
for standard rail mounting
Consisting of:
1 wiring kit
2 standard mounting rail
adapters
2 side modules
4 connecting plates

- 1 3RA19 22-1AA00
standard mounting
rail adapter
- 2 3RA19 02-1B
side modules
for standard mounting rail
adapter
(1 Order No. = 10 units)
- 3 8US19 98-1AA00
connecting plates
(1 Order No. = 100 units)
- 4 3RA19 24-2B
mechanical interlock
- 5 Motor starter protector
Size S0
- 6 Link module
for AC: 3RA19 21-1AA00
for DC: 3RA19 21-1BA00
- 7 2 contactors
Size S0

3RA19 23-2A
wiring kit

- a Upper wiring module
- b Lower wiring module

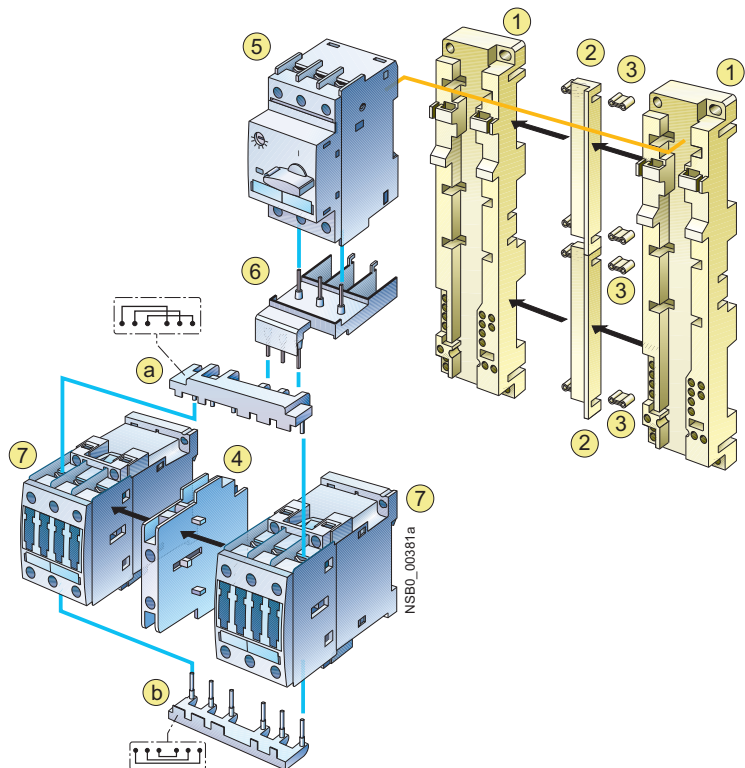

These graphical overviews are shown without small mounting parts (screws etc.).

For Operation in the Control Cabinet

3RA1 Fuseless Load Feeders

General data

Reversing duty • For standard rail mounting • Size S2

3RA19 33-1B
assembly kit (RH)
for reversing duty
for standard rail mounting
Consisting of:
1 wiring kit
2 standard mounting rail
adapters
2 side modules
4 connecting plates

- ① Motor starter protector size S2
- ② 2 contactors size S2
- ③ 3RA19 24-2B
mechanical interlock
- ④ Link module
for AC: 3RA19 31-1AA00
for DC: 3RA19 31-1BA00
- ⑤ 3RA19 32-1AA00
standard mounting rail adapter
- ⑥ 3RA19 02-1B side modules
for standard mounting rail
adapter
(1 Order No. = 10 units)
- ⑦ 8US19 98-1AA00
connecting plates
(1 Order No. = 100 units)

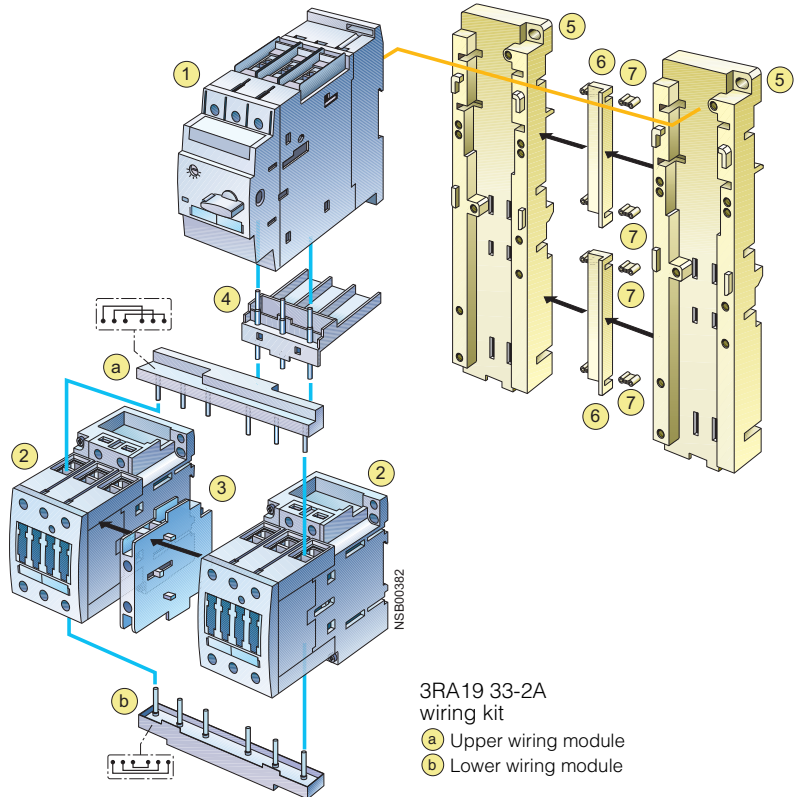

3RA19 33-2A
wiring kit

- a Upper wiring module
- b Lower wiring module

Reversing duty • For standard rail mounting • Size S3

3RA19 43-1B
assembly kit (RH)
for reversing duty
for standard rail mounting
Consisting of:
1 wiring kit
2 standard mounting rail
adapters
2 side modules
4 connecting plates

- ① Motor starter protector size S3
- ② 2 contactors size S3
- ③ 3RA19 24-2B
mechanical interlock
- ④ Link module
for AC: 3RA19 41-1AA00
for DC: 3RA19 41-1BA00
- ⑤ 3RA19 42-1AA00
standard mounting rail adapter
- ⑥ 3RA19 02-1B side modules
for standard mounting rail
adapter
(1 Order No. = 10 units)
- ⑦ 8US19 98-1AA00
connecting plates
(1 Order No. = 100 units)

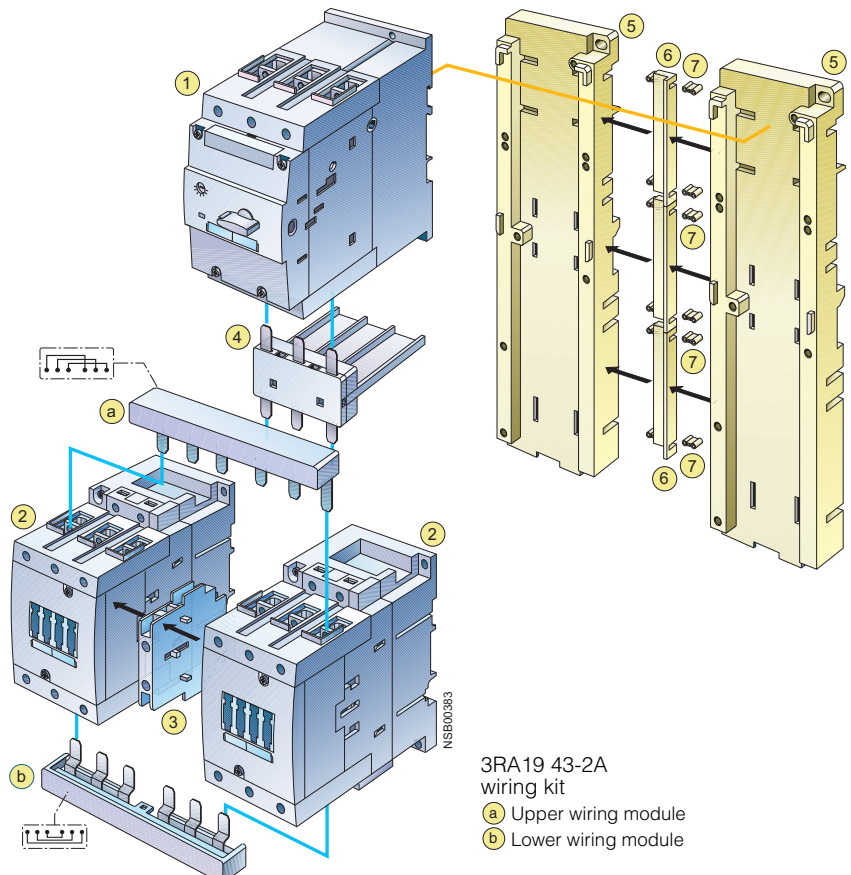

3RA19 43-2A
wiring kit

- a Upper wiring module
- b Lower wiring module

These graphical overviews are shown without small mounting parts (screws etc.).

For Operation in the Control Cabinet

3RA1 Fuseless Load Feeders

General data

Reversing duty • For 40 mm and 60 mm busbar systems • Size S00 and S0

Assembly kit (RH)
for reversing duty
for busbar mounting
40 mm: 3RA19 13-1C
60 mm: 3RA19 13-1D
Consisting of:
1 wiring kit
2 busbar adapters
1 device holder
2 connecting plates

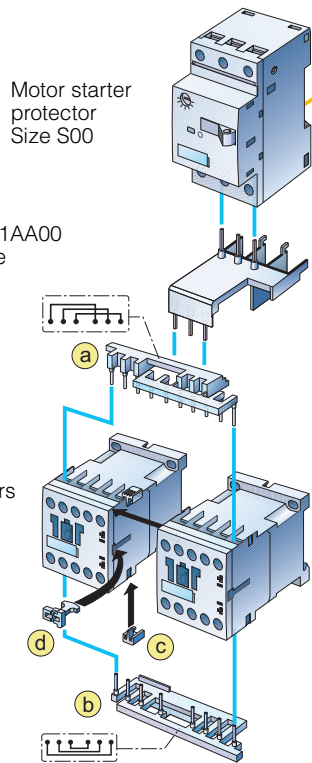

3RA19 11-1AA00
link module

2 contactors
Size S00

3RA19 13-2A
wiring kit

- (a) Upper wiring module
- (b) Lower wiring module
- (c) 2 connecting clips
- (d) Mechanical interlock
(can be removed)

Motor starter
protector
Size S0

3RA19 21-1DA00
link module

2 contactors
Size S00

Assembly kit (RS)
for reversing duty
for busbar mounting
40 mm: 3RA19 23-1C
60 mm: 3RA19 23-1D
Consisting of:
1 wiring kit
2 busbar adapters
1 device holder
1 side module
2 connecting plates

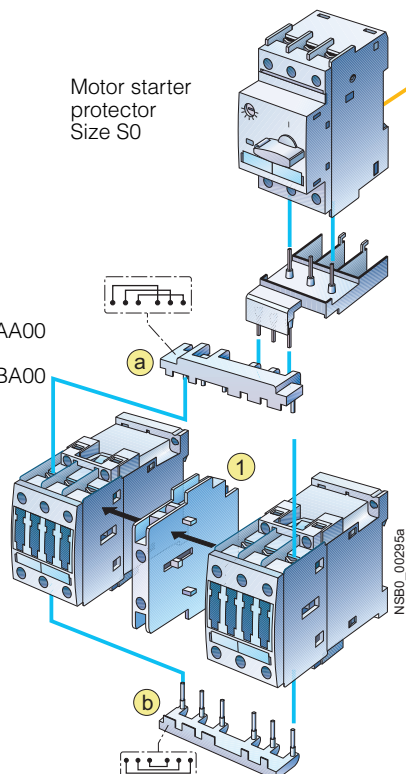

Link module
for AC:
3RA19 21-1AA00
for DC:
3RA19 21-1BA00

2 contactors
Size S0

3RA19 23-2A
wiring kit

- (a) Upper wiring module
- (b) Lower wiring module

Device holders
for size S00
40 mm: 8US10 50-5AM00
60 mm: 8US12 50-5AM00

Device holders
for size S0
40 mm: 8US10 60-5AM00
60 mm: 8US12 60-5AM00

Busbar adapters
40 mm:
8US10 51-5DM07
60 mm:
8US12 51-5DM07

- (1) 3RA19 24-2B
mechanical interlock
- (2) 8US19 98-1AA00
connecting plates
(1 Order No. = 100 units)

These graphical overviews are shown without small mounting parts (screws etc.).

For Operation in the Control Cabinet

3RA1 Fuseless Load Feeders

General data

Reversing duty • for 60 mm busbar systems • size S2

Assembly kit (RS)
for reversing duty
for busbar mounting
60 mm: 3RA19 33-1D
Consisting of:
1 wiring kit
2 busbar adapters
1 device holder
1 side module
2 connecting plates (3)

- ① Link module
for AC: 3RA19 31-1AA00
for DC: 3RA19 31-1BA00
- ② 3RA19 24-2B
mechanical interlock
- ③ 8US19 98-1AA00
connecting plates
(1 Order No. = 100 units)
- ④ Device holders
60 mm: 8US12 60-5AP00
with 8US19 98-2BM00
side module
for busbar adapter
- ⑤ Busbar adapter
60 mm: 8US12 61-5FP08

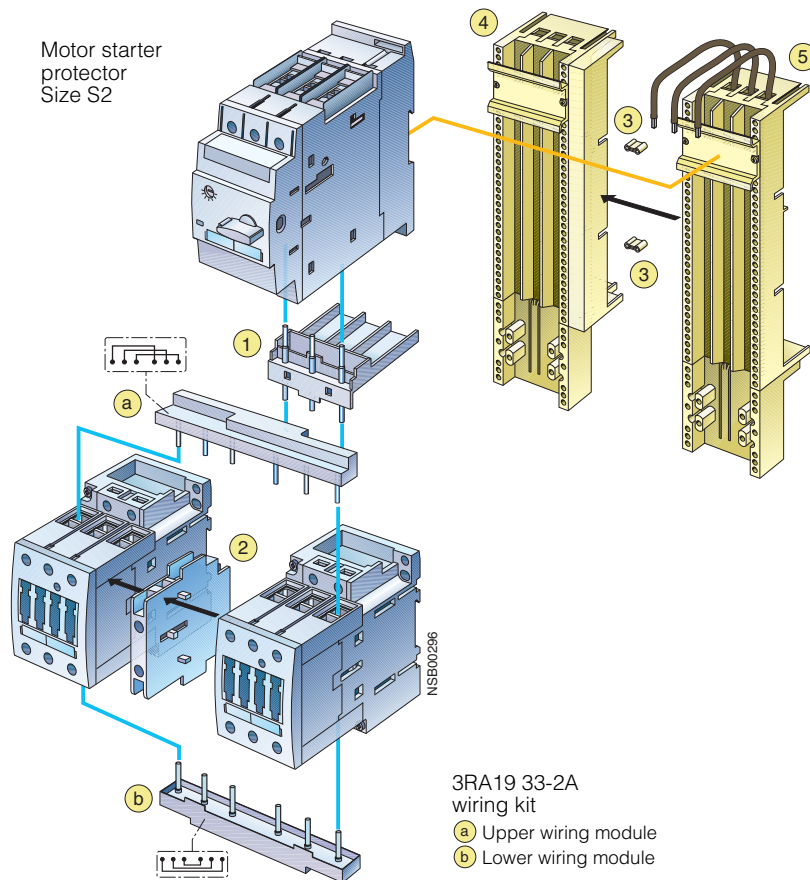

These graphical overviews are shown without small mounting parts (screws etc.).

For Operation in the Control Cabinet

3RA1 Fuseless Load Feeders

General data

Installation guidelines for 400/500 V AC

The following clearances from grounded components must be observed when installing combinations:

Motor starter protectors in combination with contactors			Clearance to grounded or live parts acc. to IEC 60947-4		
Motor starter protector	Contactors	Rated operational voltage	Y mm	X2 ¹⁾ mm	Z mm
3RV1. 1 with	3RT10 1	400/500 V	20	10	9
3RV1. 2 with	3RT1. 1	400/500 V	30	10	9
	3RT1. 2	400/500 V	30	10	9
	3RT1. 3	400/500 V	30	10	9
3RV1. 3 with	3RT10 2	400/500 V	50	10	10
	3RT1. 3	400/500 V	50	10	10
	3RT10 4	400/500 V	50	10	10
3RV1. 4 with	3RT10 4	400 V	90	10	12
	3RT10 4	500 V	220	10	20

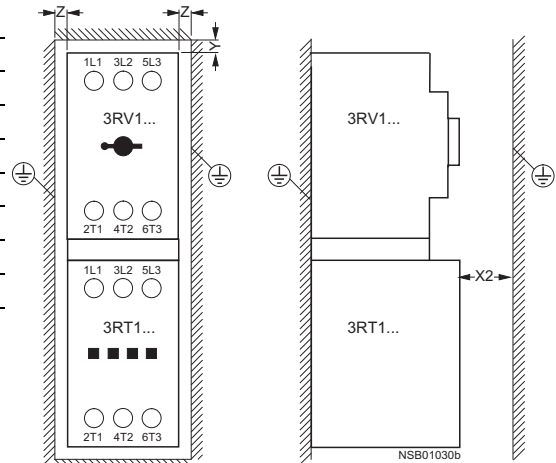

¹⁾ Minimum clearance to contactor at front. For the motor starter protector, no minimum clearance at the front must be maintained.

Installation guidelines for 690 V AC

For assembling fuseless load feeders for 690 V, one upstream and one downstream motor starter protector are required. If the sum of the set currents does not exceed the rated or set current of the upstream motor starter protector, several downstream motor starter protectors can also be used in parallel. The motor starter protectors must be placed adjacent to each other and can be connected with the wiring modules specified below.

The contactor can be fitted with a link module under the downstream motor starter protector. If contactor assemblies are used

for reversing duty, the assembly must be mounted so that the space beneath the upstream motor starter protector (infeed side) remains free.

Size	Mounting methods	Standard mounting for size S0 ... 5.5 kW, S2 and S3	Mounting for size S0 from 7.5 ... 11 kW
------	------------------	---	---

S0 Mounting on an insulated base plate. If screws are used for mounting, the screws must not be grounded. Alternatively, the standard mounting rail adapter can be used without restriction.

S2/S3 Mounting on an insulated base plate. Alternatively, the standard mounting rail adapter can also be used.

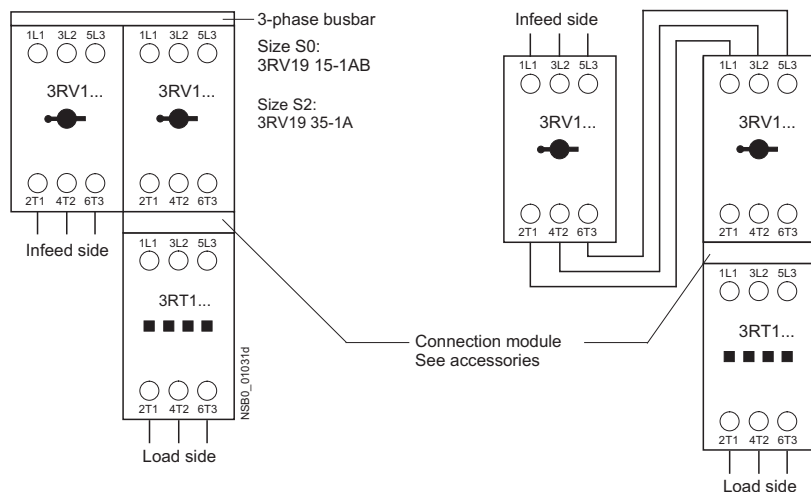

For Operation in the Control Cabinet

3RA1 Fuseless Load Feeders

General data

The following clearances from grounded components must be observed when installing combinations:

Two motor starter protectors in combination with contactors			Clearance to grounded or live parts acc. to IEC 60947-4					
Motor starter protector	Contactors	Rated operational voltage	Y1 mm	Y2 mm	Y3 mm	X1 mm	X2 mm	Z mm
3RV1. 2 with	3RT10 2	690 V	80	10	95	20	14	20
3RV1. 3 with	3RT10 3	690 V	50	10	120	10	32	10
	3RT10 4	690 V	50	10	120	10	40	10

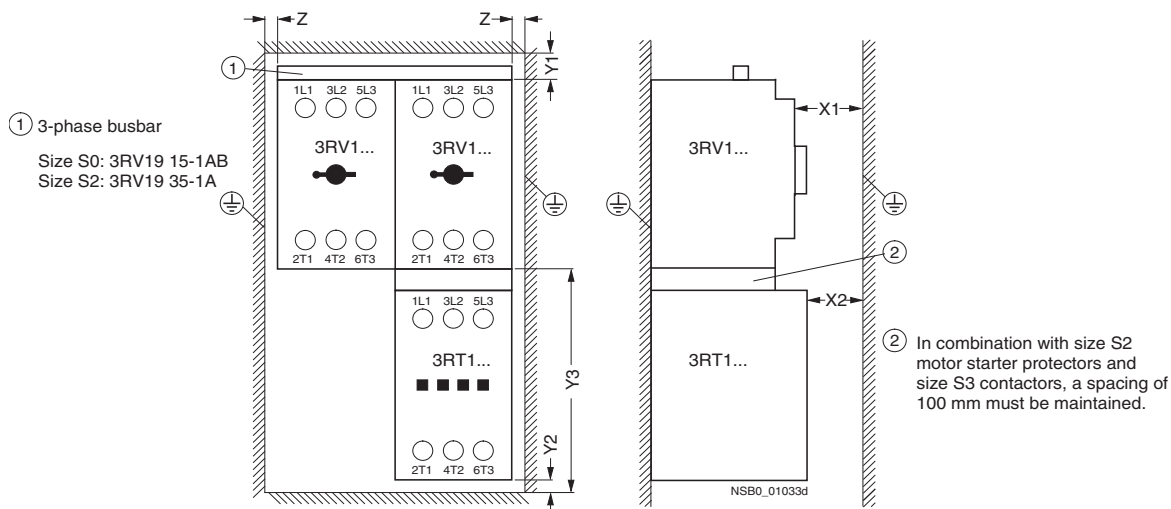

Clearances to grounded parts for 3VL circuit breakers

Circuit breakers	Rated operational voltage U_e	Clearance from grounded parts			
		A	B	C	D
3VL2/3VL3¹⁾	max. 400	100	25	30	87
3VL2/3VL3²⁾	400 ... 525	100	25	30	87
3VL4/3VL5¹⁾	max. 525	100	35	30	106.5

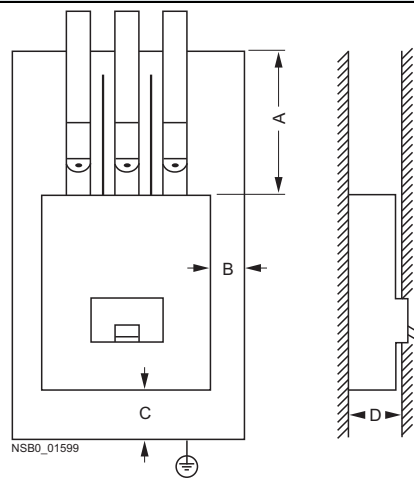

¹⁾ The 3VL9 300-8CE00 phase barriers (for 3VL2/3VL3) or 3VL9 600-8CE00 phase barriers (for 3VL4/3VL5) must be used.
²⁾ The 3VL9 300-8C..0 terminal cover must be used.

For Operation in the Control Cabinet

3RA1 Fuseless Load Feeders

General data

Clearances from grounded parts for 3RT10 5./
3RT10 6./3RT10 7. and 3RT12 6./3RT12 7. contactors

Contactors	Clearance from grounded parts, rated operational voltage up to 690 V		
	G	H	I
3RT10 5.	40	10	20
3RT10 6./3RT12 6.	20	10	20
3RT10 7./3RT12 7.	20	10	20

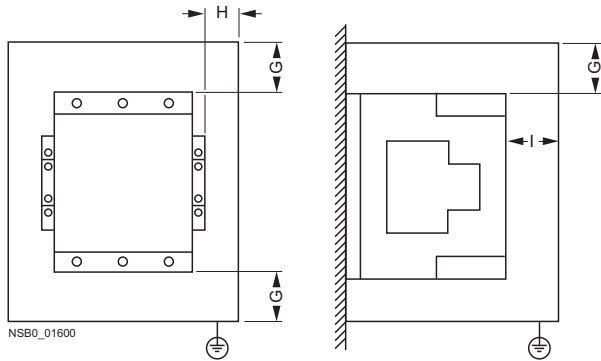

G = Clearance from box terminal.

In applications with cable lugs or busbar connection the 3RT19 56-4EA1 (3RT10 5) or 3RT19 66-4EA1 (3RT10 6., 3RT12 6., 3RT10 7. or 3RT12 7.) terminal cover must be used!

For Operation in the Control Cabinet

3RA1 Fuseless Load Feeders

General data

Technical specifications

Type Size Number of poles		3RA1. 1 S00 3	3RA1. 2 S0 3	3RA1. 3 S2 3	3RA1. 4 S3 3	
General data						
Standards		IEC 60947-1, EN 60947-1 IEC 60947-2, EN 60947-2 IEC 60947-4-1, EN 60947-4-1				
Max. rated current $I_{n \max}$ (= max. rated operational current I_B)	A	12	25	50	100	
Permissible ambient temperature	°C	-20 ... +70 for operation (up to +60 °C without restriction)				
	°C	-55 ... +80 during storage/transport				
Rated operational voltage U_e	V	690				
Rated frequency	Hz	50/60				
Rated insulation voltage U_i (degree of pollution 3)	V	690				
Rated impulse withstand voltage U_{imp}	kV	6				
Trip class (CLASS)	Acc. to IEC 60947-4-1, EN 60947-4-1	10				
Rated short-circuit current I_{sc} at AC 50/60 Hz 400 V acc. to IEC 60947-4-1, EN 60947-4-1	kA	50				
Types of coordination acc. to IEC 60947-4-1, EN 60947-4-1		1)				
Power loss $P_{V \max}$ of all main current paths	Up to 1.25 A 1.6 ... 6.3 A	W	6			
Dependent on the rated current	8 ... 12 A	W	7			
I_n (upper setting range)	2 ... 6.3 A	W	10.5			
	8 ... 16 A	W		7		
	20 ... 25 A	W		9.5		
	25 ... 32 A	W		13		
	40 A	W			19	
	45 ... 50 A	W			28	
	63 A	W			35	
	75 ... 90 A	W				29
	100 A	W				45
						60
Power consumption of the magnetic coils in the case of contactors (for cold coil and U_s , 50 Hz)						
• AC operation	Closing	VA	27	61	127	270
	P.f.		0.8	0.82	0.82	0.68
	Closed	VA	4.6	7.8	13.5	22
	P.f.		0.27	0.24	0.34	0.27
• DC operation	Closing = Closed	W	3.2	5.4	11.5	15
Magnetic coil operating range for contactors			0.8 ... 1.1 x U_s			
	Low limit at 55 °C		0.8 x U_s	--		
	at 60 °C		0.85 x U_s	--		
Endurance of the motor starter protector						
• Mechanical endurance	Operating cycles		100 000		50 000	
• Electrical endurance	Operating cycles		100 000		50 000	
• Max. switching frequency per hour (motor starts)		1/h	15		15	
Endurance of contactor						
• Mechanical endurance	Operating cycles		30 million	10 million		
• Electrical endurance	Operating cycles		2)			
Shock resistance (sine-wave pulse)	Acc. to IEC 60086 Part 2-27	g	Up to 9.8	Up to 12.5	Up to 8	Up to 6
Degree of protection	Acc. to IEC 60947-1		IP20			
Touch protection	Acc. to EN 50274		Finger-safe			
Phase failure sensitivity of the motor starter protector	Acc. to IEC 60947-1, EN 60947-1		Yes			
Isolating features of the motor starter protector	Acc. to IEC 60947-2, EN 60947-2		Yes			
Main control and EMER- GENCY-STOP switch charac- teristics of the motor starter protector and accessories	Acc. to IEC 60204-1, EN 60204-1		Yes, (with overvoltage releases of category 1 under conditions of proper use)			
Protective separation between main and auxiliary circuits	Acc. to EN 60947-1, Appendix N	V	Up to 400			
Positively-driven operation at contactors			Yes	Yes, from main contact to auxiliary NC contact		

1) See "Selection and ordering data".

2) See endurance characteristics of the contactors under "Controls:
Contactors and Contactor Assemblies".

For Operation in the Control Cabinet

3RA1 Fuseless Load Feeders

General data

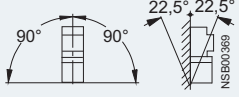
Type	3RA1. 1	3RA1. 2	3RA1. 3	3RA1. 4
Size	S00	S0	S2	S3
Number of poles	3	3	3	3
Conductor cross-sections of main circuit				
Standards	IEC 60947-1, EN 60947-1 IEC 60947-2, EN 60947-2 IEC 60947-4-1, EN 60947-4-1			
Connection type	Screw terminals	Screw terminals	Box terminal	Box terminal
Terminal screw	Pozidriv size 2	Pozidriv size 2	Pozidriv size 2	Allen screw
Minimum/maximum conductor cross-sections				
Finely stranded with end sleeve				
• 1 conductor	mm ² 0.5/2.5	1/6	0.75/25	2.5/50 ¹⁾
• 2 conductors	mm ² 0.5/2.5	1 ... 2.5/2.5 ... 6	0.75/16	2.5/35
Solid or stranded				
• 1 conductor	mm ² 0.5/4	1/6	0.7/35	2.5/70
• 2 conductors	mm ² 0.75/2.5	1 ... 2.5/2.5 ... 6	0.75/25	2.5/50
Connection, main contacts, ribbon cable conductors			Yes	Yes
Busbar connections			Yes	Yes
• Solid or stranded	AWG 2 x (18 ... 14)	2 x (14 ... 10)	2 x (30 ... 2)	--
• Stranded	AWG --	--	--	2 x (10 ... 1/0)
Connection type	Cage Clamp terminals			
	mm ² 2 x (0.5 ... 2.5)	--		
	AWG 2 x (18 ... 14)	--		
Permissible mounting positions				
	Important: acc. to DIN 43602 Start command "I" at the right or top			

More information

Brochure "SIRIUS Configuration"

More information and assignment tables for self-assembly combinations for 400 V, 440 V, 480 V, 500 V, 550 V and 690 V can be found in the brochure "SIRIUS Configuration: Selection Data for Load Feeders in Fuseless Designs", Order No. E86060-T1815-A101-A2

or as a PDF file on the Internet at <http://www.siemens.com/lowvoltage/infomaterial> under the tab "Brochures".

For Operation in the Control Cabinet

3RA1 Fuseless Load Feeders

AS-Interface load feeder modules

Overview

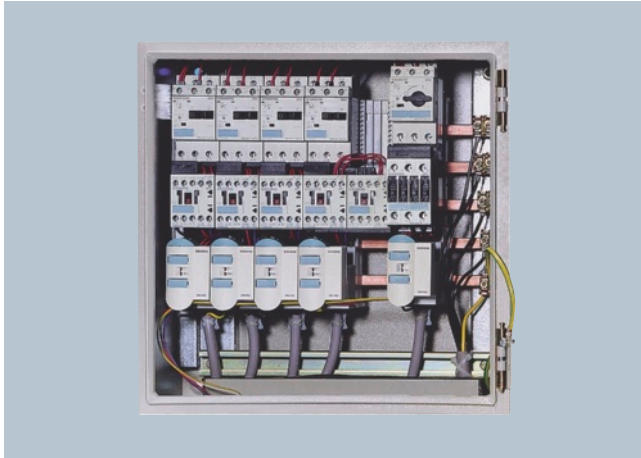

The AS-Interface load feeder module adds an input/output module to the conventional busbar and standard mounting rail adapters. With this module the control circuit of a load feeder is available completely factory-wired. The series has been optimized for operation in conjunction with the SIRIUS load feeders size S00 and S0. Connection to the higher-level automation system is made through the AS-Interface interface of the load feeder module. A non-shielded standard litz wire can be used as data line and for the auxiliary current supply. Connection to the AS-Interface load feeder module is made using two connectors with the insulation displacement connection.

Four different AS-Interface load feeder modules are available: Differences exist in the number of inputs and outputs and in the type of outputs. The units with solid-stated outputs are designed for 24 V DC, those with relay outputs are suitable for voltages of max. 230 AC. Direct-on-line and reversing starters as well as double direct-on-line starters and starter combinations can be wired therefore for pole reversal. The inputs can be used to separately scan the feedbacks from motor starter protectors and contactors. The outputs can be used for direct control of the contactor coils.

As the outputs already have overvoltage protection integrated, no additional measures for the contactors are required.

The outputs are supplied with separate auxiliary voltage – a selectively configured EMERGENCY-STOP concept is possible therefore. The inputs are supplied from the AS-Interface data line. Inputs and outputs have to be wired using integrated, spring-type terminals, each connected to a common potential.

3RA5 fuseless load feeder with connection to AS-Interface

The 3RA5 fuseless load feeder, comprised of the AS-Interface load feeder module, motor starter protector, contactor and all necessary connectors (AS-Interface, auxiliary power and 5-pole power connector), is delivered completely assembled, factory-wired and tested. The user can thus save valuable time when mounting, wiring and servicing.

Direct-on-line starters as well as reversing starters are available with SIRIUS switchgear size S00 up to 10 A and size S0 – on account of the power connector – up to 16 A. The complete feeders are available with AS-Interface load feeder modules with solid-state outputs for 24 V DC auxiliary voltage.

Load feeders with this type of configuration are used to control standard induction motors for example. The load feeders can be installed in central control cabinets as well as in local control boxes. They are particularly suitable for highly automated machines and plants that place high demands on availability.

Design

The AS-Interface load feeder module is snapped onto the matching support. As an option, a 5-pole power connector can be installed between the load feeder module and the support.

When this power connector is used, all connections of the load feeder can be plugged in. Should it become necessary to replace the unit, this can be done in a minimum of time. When this power connector is used, the current is limited to 16 A.

The support is available in different versions and must be selected to fit the width of the controlgear combination (45 mm or 54 mm) and the busbar system used (busbar center-to-center spacing 40 mm or 60 mm). Depending on the version, the N conductor and/or the PE conductor or neither are brought out as well. It is thus possible for pre-assembled connecting cables of the loads to be routed right up to the AS-Interface load feeder module and for them to be fitted there without any additional wiring outlay. Hence it is extremely easy to replace the loads, e. g. a standard induction motor.

A unique address must be assigned to each AS-Interface station at the latest for start-up. For the AS-Interface load feeder module this can be done either by using the master and successively plugging on the connectors which are connected to the data line (only one station in the network is allowed to log on with the default address 0) or by the individual addressing method using an addressing unit and an addressing cable. This type of addressing is also possible with the load feeder module fully wired, as the module is separated from the AS-Interface network when the addressing plug is connected.

The addressing socket is positioned underneath the equipment label on the front of the load feeder module. The indicator lamps (LEDs) for the diagnostics of the AS-Interface load feeder module are fitted in the same place. The following states are indicated:

- 24 V DC auxiliary voltage applied or output/outputs activated (version 230 V AC)
- AS-Interface communication OK
- AS-Interface communication faulty
- Station address equals 0 (module not addressed)

For Operation in the Control Cabinet

3RA1 Fuseless Load Feeders

AS-Interface load feeder modules

Technical specifications

		Load feeder modules IP20			
		2I/1O 3RK1 400-1KG01-0AA1	4I/2O 3RK1 400-1MG01-0AA1	2I/1AR 3RK1 402-3KG02-0AA1	3I/2AR 3RK1 402-3LG02-0AA1
I/O configuration	Hex	3	7	3	7
ID code	Hex	F			
Power supply for electronics and inputs (feedback of switchgear auxiliary contacts) using AS-Interface data line	V	26.5 ... 31.6 (acc. to AS-Interface specification)			
AS-Interface power consumption	mA	8 ... 12			
Temperature range					
• Operating temperature T_U	°C	0 ... +55			
• Storage temperature	°C	-40 ... +85			
Degree of protection		IP20			
Inputs					
• Reverse polarity protection		Built-in			
• Max. input current	mA	6			
• Max. permissible cable length between IN + and an input	m	0.4			
Outputs					
• External power supply for outputs (control of the contactor coils) using auxiliary power	V	24 DC		Max. 230 AC	
• Current carrying capacity I_e	A	0.5 (DC-13/DC-14)		3 (AC-15); 0.1 (DC-13 at 220 V)	
• Summation current (thermal) I_{th}	A	2		3	
• Reverse polarity protection		Built-in		Not required	
• Short-circuit protection		Built-in		No	
• Induction protection		Built-in		Not required	
• Watchdog function (disconnects outputs in the event of AS-Interface fault)		Built-in			
Diagnostics					
• Through LED on the enclosure		Auxiliary voltage applied AS-Interface communication OK AS-Interface communication faulty Station address = 0 (module not addressed)		Output actuated	
Conductor cross-sections					
• Connectors for AS-Interface and auxiliary power	mm ²	0.5 ... 0.75 (flexible)			
• Cage Clamp for I/O wiring	mm ²	0.8 ... 2.5 (flexible, without end sleeve)			
• Power connector, 5-pole	mm ²	0.5 ... 2.5 AWG 28 ... 12			
• PE/N conductor wiring on the support	mm ²	2.5 flexible AWG 13			
Addressing		After the 15th addressing procedure, the module retains the last address			

Note:

The same technical data apply for the load feeders as for the single devices. For example, the high short-circuit strength of $I_q = 50 \text{ kA}$ also applies.

For Operation in the Control Cabinet

3RA1 Fuseless Load Feeders

AS-Interface load feeder modules

Schematics

Typical circuits for the control circuit

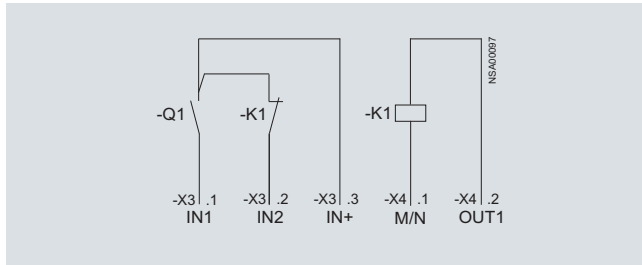

AS-Interface load feeder module with 2 inputs and 1 output as direct-on-line starter

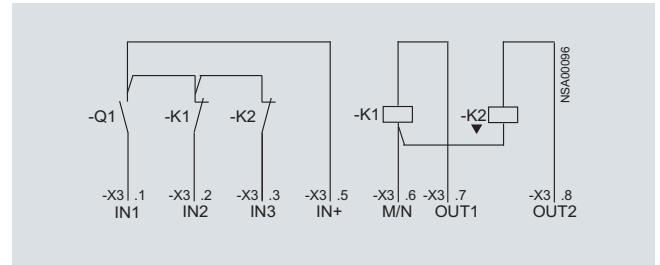

AS-Interface load feeder module with 4 inputs and 2 outputs or 3 inputs and 2 outputs as reversing starter

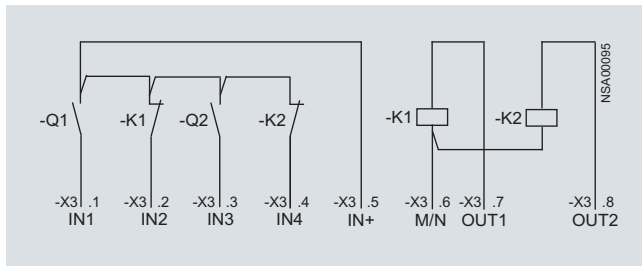

AS-Interface load feeder module with 4 inputs and 2 outputs as double direct-on-line starter

Note:

When using SIRIUS contactors we recommend wiring the positively driven auxiliary NC contacts for feedback of the switching state.

For Operation in the Control Cabinet

3RA1 Fuseless Load Feeders

3RV19 infeed system

Overview

The 3RV19 infeed system is a convenient means of energy supply and distribution for a group of several motor starter protectors or complete load feeders with a screw or spring-type connection up to size S0.

The devices with spring-type connections are available in the SIRIUS modular system up to 5.5 kW at 400 V AC. The motor starter protectors and load feeders with screw terminals for sizes S00 and S0 can also be integrated in the system at the same time.

The system is based on a basic module complete with a lateral incoming unit (three-phase busbar with infeed). This infeed with spring-type terminals is mounted on the right or left depending on the version and can be supplied with a maximum conductor cross-section of 25 mm² (with end sleeve). A basic module has two sockets onto each of which a motor starter protector can be snapped.

Expansion modules are available for extending the system (3-phase busbars for system expansion). The individual modules are connected through an expansion plug.

The electrical connection between the 3-phase busbars and the motor starter protectors is implemented through plug-in connec-

tors. The complete system can be mounted on a TH 35 standard mounting rail to EN 60715 and can be expanded as required up to a maximum current carrying capacity of 80 A.

The system is mounted extremely quickly and easily thanks to the simple plug-in technique. Thanks to the lateral infeed, the system also saves space in the control cabinet. The additional overall height required for the infeed unit is only 30 mm. The alternative infeed possibilities on each side offer a high degree of flexibility for configuring the control cabinet: Infeed on left-hand or right-hand side, ring infeed or infeed on one side and outfeed on the other side to supply further loads are all possible. A terminal block with spring-type connection in combination with a standard mounting rail enables the integration of not only SIRIUS motor starter protectors but also single-phase, two-phase and three-phase components such as 5SY miniature circuit breakers or SIRIUS relay components.

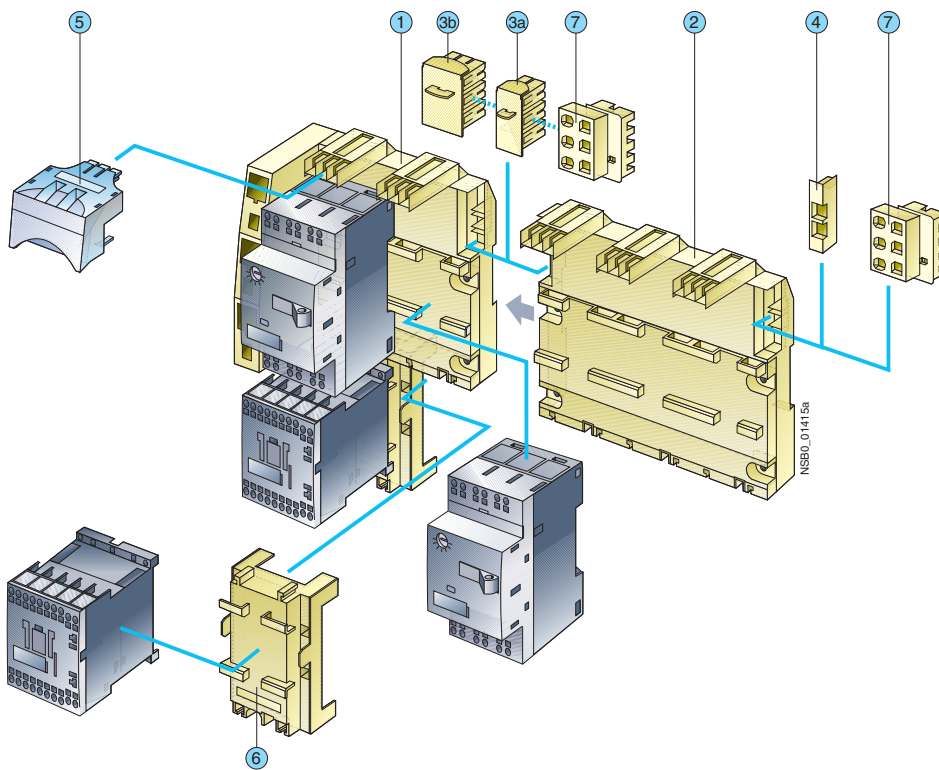

- ① 3-phase busbar with infeed
- ② 3-phase busbar for system expansion
- ③a Expansion plug
- ③b Extra-wide expansion plug
- ④ End cover
- ⑤ Plug-in connector
- ⑥ Contactor base
- ⑦ Terminal block

For Operation in the Control Cabinet

3RA1 Fuseless Load Feeders

3RV19 infeed system

① 3-phase busbars with infeed

A 3-phase busbar with infeed unit is required for connecting the incoming supply. This module comprises one infeed module and 2 sockets which each accept one motor starter protector. A choice of two versions with infeed on the left or right is available. The infeed is connected using spring-type terminals. The Cage Clamp springs permit conductor cross-sections of up to 25 mm² with end sleeves. An end cover is supplied with each module.

② 3-phase busbars for system expansion

The 3-phase busbars for system expansion support expansion of the system. There is a choice of modules with 2 or 3 sockets. The system can be expanded as required up to a maximum current carrying capacity of 63 A. An expansion plug is supplied with each module.

③a Expansion plug

The expansion plug is used for electrical connection of adjacent 3-phase busbars. The current carrying capacity of this plug equals 63 A. One expansion plug is supplied with each 3-phase busbar for system expansion. Additional expansion plugs are therefore only required as spare parts.

③b Extra-wide expansion plug

The extra-wide expansion plug makes the electrical connection between two 3-phase busbars, thus performing the same function as the 3RV19 17-5BA00 expansion plug; the electrical characteristics (e. g. a current carrying capacity of 63 A) are identical.

The 3RV19 17-5E expansion plug is 10 mm wider than the 3RV19 17-5BA00 expansion plug, hence in the plugged state there is a distance of 10 mm between the connected 3-phase busbars. This distance can be used to lay the auxiliary current and control current wiring ("wiring duct"). The motor starter protector and contactor can be wired from underneath, which means that the complete cable duct above the system can be omitted.

④ End cover

The end cover is used to cover the 3-phase busbar at the open end of the system. This cover is therefore only required once for each system. An end cover is supplied with each 3-phase busbar system with infeed. Further end covers are therefore only required as spare parts.

⑤ Plug-in connector

The plug-in connector is used for the electrical connection between the 3-phase busbar and the motor starter protector. There are three different versions:

- One version for 3RV motor starter protectors size S00 with screw terminals
- One version for 3RV motor starter protectors size S0 with screw terminals
- One version for 3RV motor starter protectors size S00 with spring-type terminals

⑥ Contactor base

Load feeders can be assembled in the system using the contactor base. The contactor bases are suitable for contactors of size S00 with spring-type terminals and are simply snapped onto the 3-phase busbars. Direct-on-line starters and reversing starters are possible. One contactor base is required for direct-on-line starters and two are required for reversing starters. To assemble load feeders for reversing starters, the contactor bases can be arranged either below each other (45 mm overall width) or alongside each other (90 mm overall width). It is important to note that mechanical interlocking of the contactors is only possible when they are arranged vertically.

The infeed system is designed for mounting on a 35 mm standard mounting rail with 7.5 mm overall depth. This standard mounting rail gives the contactor base a stable mounting surface to sit on. If standard mounting rails with a depth of 15 mm are used, the spacer connected to the bottom of the contactor base must be knocked out and plugged into the mating piece that is also on the underside. Then the contactor base also has a stable mounting surface. When standard mounting rails with a depth of 7.5 mm are used, the spacer has no function and can be removed.

As an alternative to using a contactor base, the 3RA19 11-2E electrical link modules can also be used for direct start load feeders of size S00. Motor starter protector and contactor assemblies can then be directly snapped onto the sockets of the 3-phase busbars. For feeders of size S00 and S0, the corresponding 3RA19 11-1... or 3RA19 21-1... link modules should generally be used. For size S0, it is only possible integrate direct start load feeders and they must be integrated in the system as complete assemblies.

⑦ Terminal block

The 3RV19 17-5D terminal block enables the integration of not only SIRIUS motor starter protectors but also single-phase, two-phase and three-phase components in addition. Using the terminal block the 3 phases can be fed out of the system; single-phase loads can also be integrated in the system as the result. The terminal block is plugged into the slot of the expansion plug and thus enables outfeeding from the middle or end of the infeed system. The terminal block can be rotated through 180 ° and be locked to the support modules of the infeed system. The 3RV19 17-7B 45 mm standard mounting rail for screwing onto the support plate is available in addition in order to be able to plug the single-phase, two-phase and three-phase components onto the infeed system.

For Operation in the Control Cabinet

3RA1 Fuseless Load Feeders

3RV19 infeed system

Design

Installation guidelines

Distance in Y direction from live, earthed or insulated parts according to IEC 60947-4: 10 mm.

In addition, the installation guidelines for motor starter protectors or fuseless load feeders including the clearances must be complied with.

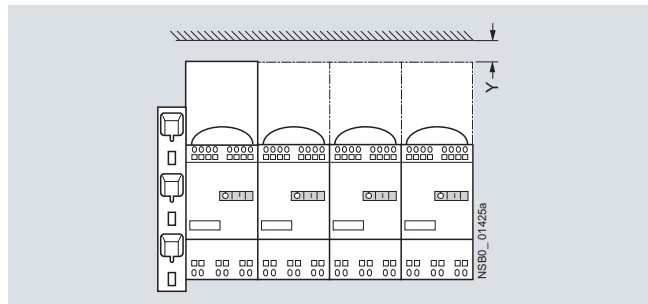

Installation guidelines for 3RV19 17-5D terminal block

The short-circuit device which is connected upstream from the infeed system must be configured in accordance with the conductor cross-section on the infeed block.

Conductor cross-section on 3RV19 17-1A/-1E infeed block mm ²	Upstream short-circuit device		
	Recommendation (for 400 V)	$I_d \max$ kA	I^2t kA ² s
4	3RV10 21-4DA10	< 9.5	85
6	3RV10 31-4EA10	< 12.5	140
10	3RV10 31-4HA10	< 15	180
16/25	3RV10 42-4JA10	19	440

The short-circuit device which is connected downstream from the terminal block must be configured in accordance with the conductor cross-section on the terminal block as per the following table.

Conductor cross-section on 3RV19 17-5D terminal block mm ²	Downstream short-circuit device, e. g. 5SY	
	$I_d \max$ kA	
1.5	< 7.5	To prevent short-circuits, the cables on the terminal block must be installed so that they are short-circuit resistant acc. to EN 60439-1 Section 7.5.5.1.2.
2.5	< 9.5	
4	< 9.5	
6	< 12.5	
10	< 12.5	

Technical specifications

Type	3RV19 .7	
Rated operational voltage U_e		
• IEC	V	500
- 10 % overvoltage	V	525
- 5 % overvoltage	V	600
• UL/CSA		
Rated frequency	Hz	50/60
Rated current I_n	A	63
Permissible ambient temperature		
• During storage/transport	°C	-50 ... +80
• During operation	°C	-20 ... +60
Permissible rated current of the 3RV10 11 motor starter protectors (size S00) at control cabinet internal temperature		
• +60 °C	%	100
Permissible rated current of the 3RV10 21 motor starter protectors (size S0) up to 16 A at control cabinet internal temperature		
• +60 °C	%	100
Permissible rated current for 3RV1. 21 motor starter protectors (size S0) from 16 A at control cabinet internal temperature		
• +40 °C	%	100
• +60 °C	%	87
Degree of protection acc. to IEC 60529		IP20 ¹⁾
Touch protection acc. to IEC 61140		Finger-safe
Conductor cross-sections for main circuit infeed		
• Solid, stranded:	mm ²	4 ... 25
• Finely stranded with end sleeve	mm ²	4 ... 25
• Finely stranded without end sleeve	mm ²	6 ... 25
• AWG cables, solid or stranded	AWG	10 ... 3
Conductor cross-sections of terminal block		
• Solid	mm ²	1.5 ... 6
• Finely stranded with end sleeve	mm ²	1.5 ... 4
• Finely stranded without end sleeve	mm ²	1.5 ... 6
• AWG cables, solid or stranded	AWG	15 ... 10

¹⁾ In infeed terminal compartment without a conductor connected: IP00.

For Operation in the Control Cabinet

3RA1 Fuseless Load Feeders

Project planning aids

Dimensional drawings

3RA fuseless load feeders

Size S00 · For standard rail mounting

3RA11 10- . . A . .

Direct-on-line start

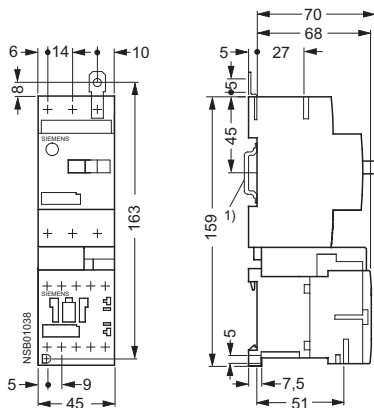

3RA12 10- . . A . .

Reversing duty

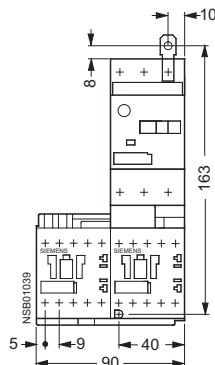

Size S00 · For 40 mm and 60 mm busbar systems

3RA11 10- . . C . .

3RA11 10- . . D . .

Direct-on-line start

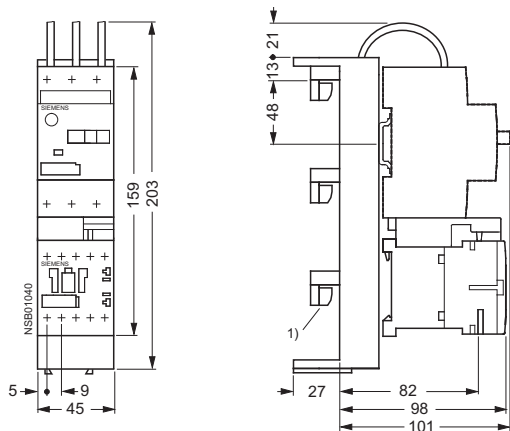

3RA12 10- . . C . .

3RA12 10- . . D . .

Reversing duty

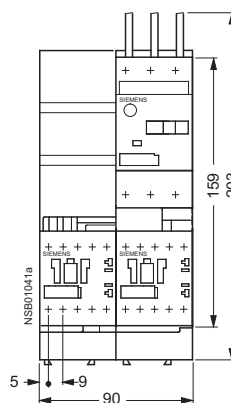

1) Busbar adapters suitable for a busbar thickness of 5 and 10 mm with chamfered edges.

6

For Operation in the Control Cabinet

3RA1 Fuseless Load Feeders

Project planning aids

Size S0 · For standard rail mounting

3RA11 20-. . A . .

Direct-on-line start

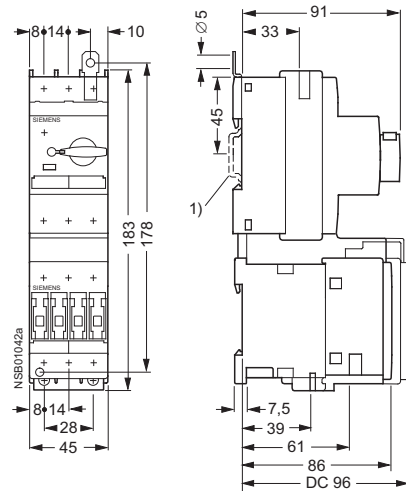

1) Mounting with one TH 35 standard mounting rail according to EN 60715
Depth: 7.5 or 15 mm.

3RA12 20-. . A . .

Reversing duty

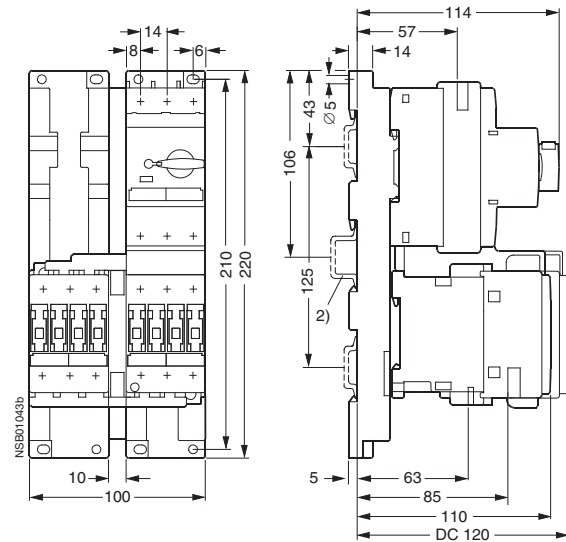

2) Alternative mounting methods

- a) Two TH 35 standard mounting rails according to EN 60715
Distance: 125 mm
Depth: 7.5 or 15 mm.
- b) One TH 35 standard mounting rail according to EN 60715
Depth: 15 mm.

Size S0 · For 40 mm and 60 mm busbar systems

3RA11 20-. . C . .

3RA11 20-. . D . .

Direct-on-line start

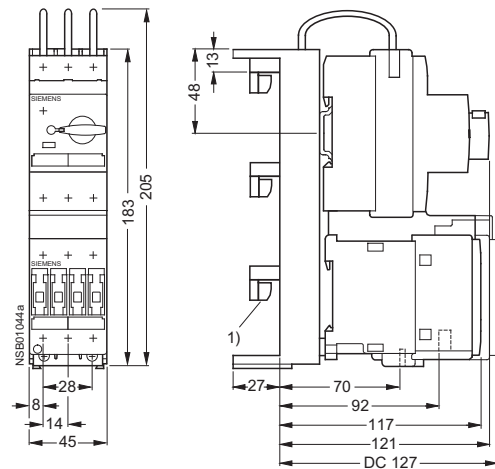

1) Busbar adapters suitable for a busbar thickness of 5 and 10 mm with chamfered edges.

3RA12 20-. . C . .

3RA12 20-. . D . .

Reversing duty

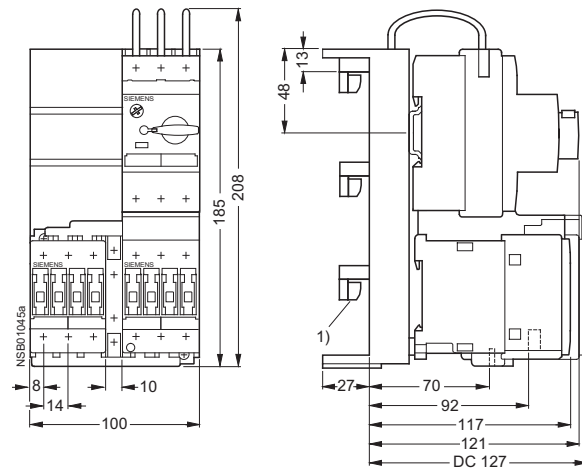

For Operation in the Control Cabinet

3RA1 Fuseless Load Feeders

Project planning aids

Size S2 · For standard rail mounting

Direct-on-line start

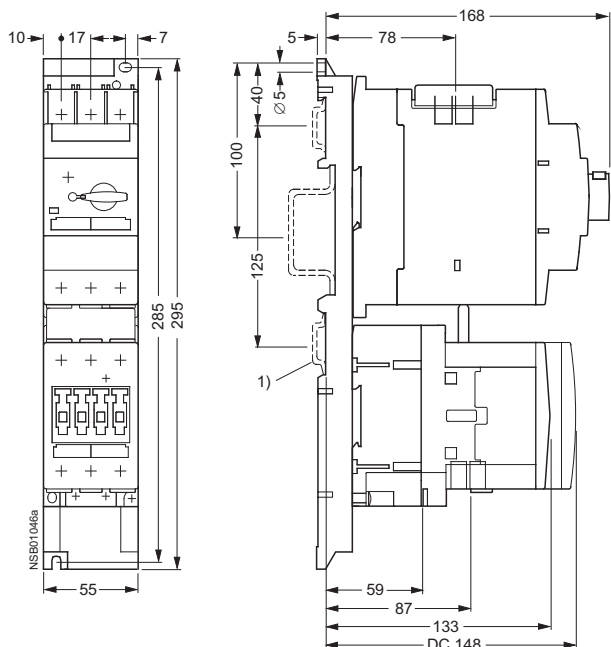

Reversing duty

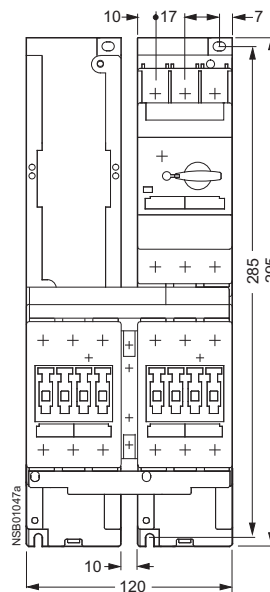

1) Alternative mounting methods

- a) Two TH 35 standard mounting rails according to EN 60715
Distance: 125 mm
Depth: 7.5 or 15 mm.
- b) One TH 75 standard mounting rail according to EN 60715
Depth: 15 mm.

Size S2 · For 40 mm and 60 mm busbar systems

Direct-on-line start

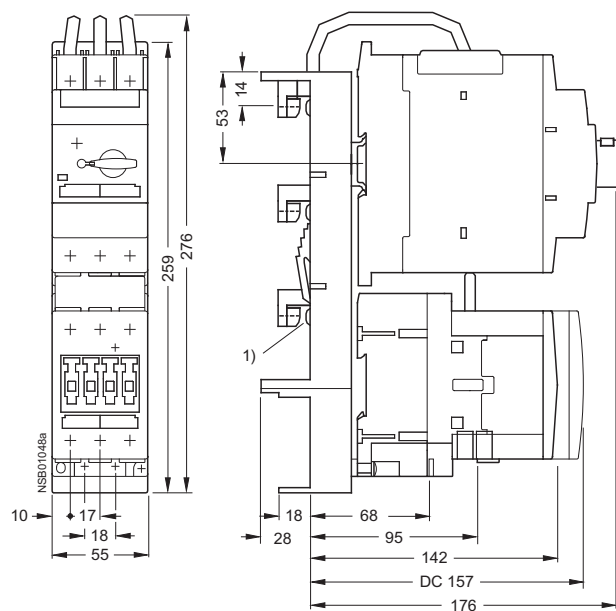

Reversing duty

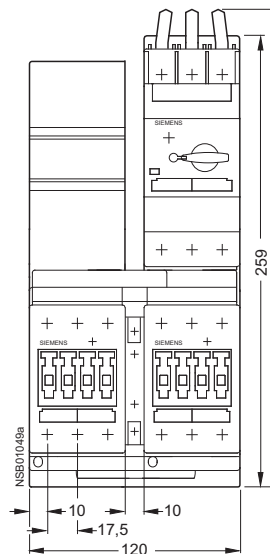

1) Busbar adapters suitable for a busbar thickness of 5 and 10 mm with chamfered edges.

For Operation in the Control Cabinet

3RA1 Fuseless Load Feeders

Project planning aids

Size S3 · For standard rail mounting

Direct-on-line start

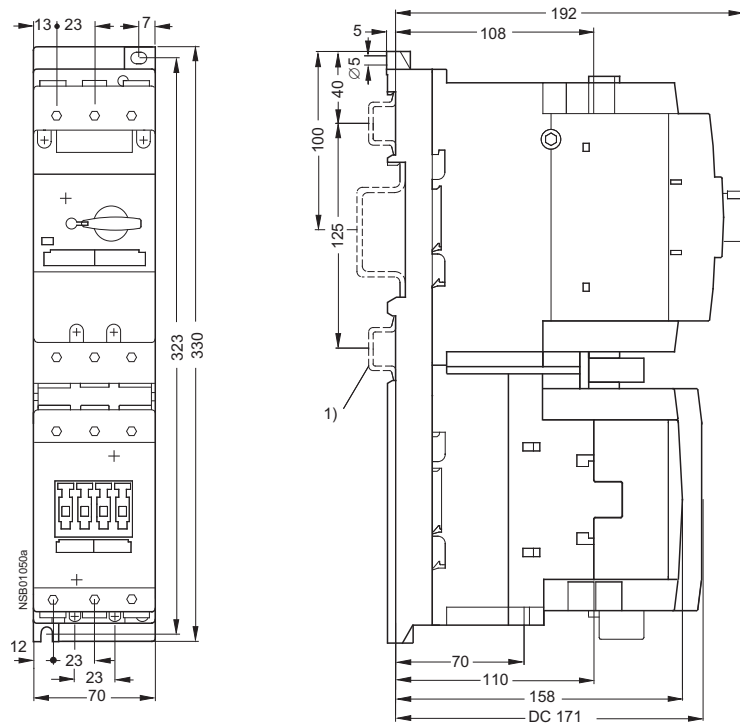

Reversing duty

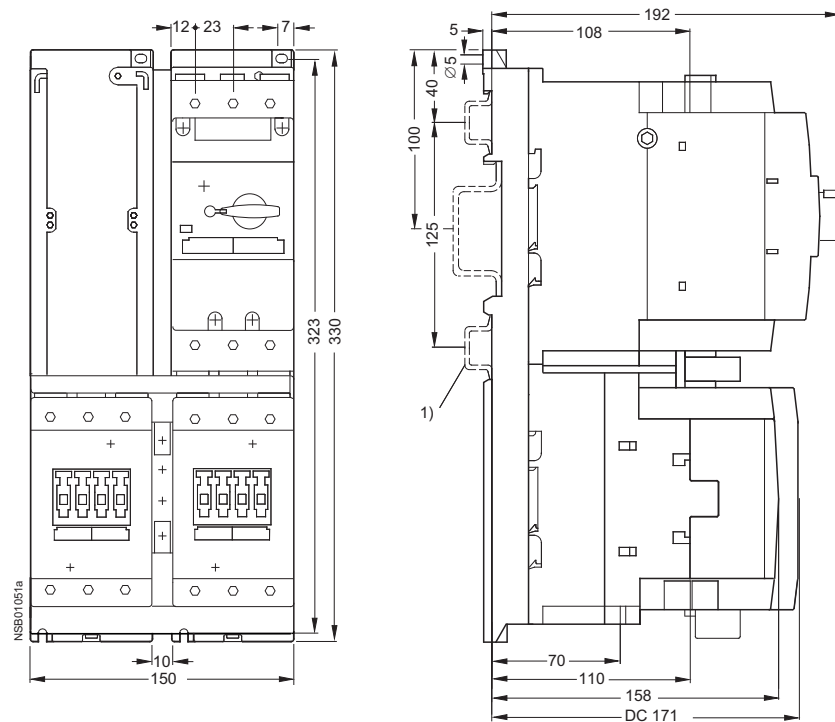

1) Alternative mounting methods

- a) Two TH 35 standard mounting rails according to EN 60715
Distance: 125 mm
Depth: 7.5 or 15 mm.
- b) One TH 75 standard mounting rail according to EN 60715
Depth: 15 mm.

For Operation in the Control Cabinet

3RA1 Fuseless Load Feeders

Project planning aids

3RV19 infeed system

3-phase busbars with infeed

For 2 motor starter protectors size S00 and S0, with 3RV19 17-1. + 3RV19 17-5BA00 expansion plug

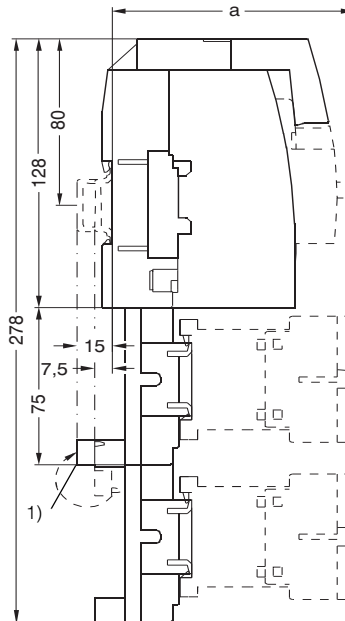
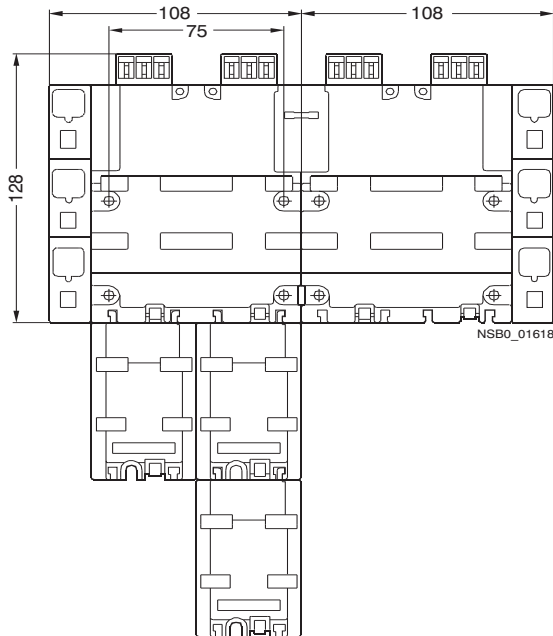

	S00	S0
a	104	125

3-phase busbars for system expansion

For 2 and 3 motor starter protectors size S00 and S0 with 3RV19 17-4. + 3RV19 17-5E extra-wide expansion plug and 3RV19 17-5D terminal block

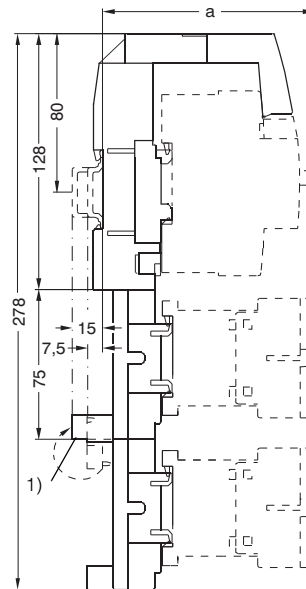
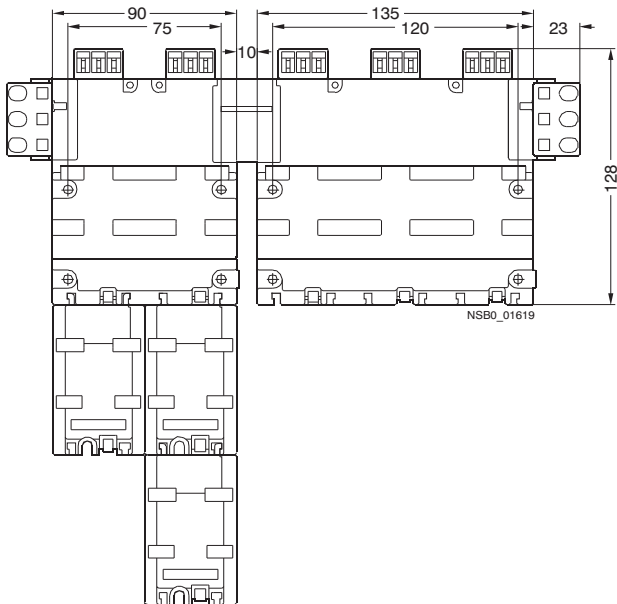

	S00	S0
a	104	125

1) Alternative mounting methods (see 3RV19 Infeed System, Design)

- a) One TH 35 standard mounting rail according to EN 60715
Depth: 7.5 mm
Spacer not used.
- b) One TH 35 standard mounting rail according to EN 60715
Depth: 15 mm
Spacer plugged into mating piece.

For Operation in the Control Cabinet

3RA1 Fuseless Load Feeders

Project planning aids

Schematics

3RA fuseless load feeders

Direct-on-line start

Size S00

3RA11 1

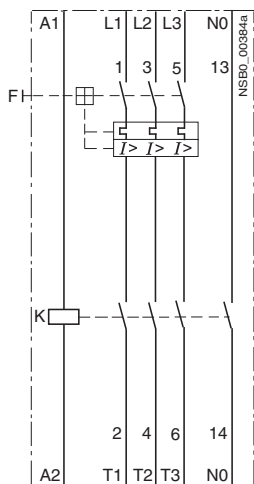

Size S0, S2 and S3

3RA11 2,

3RA11 3

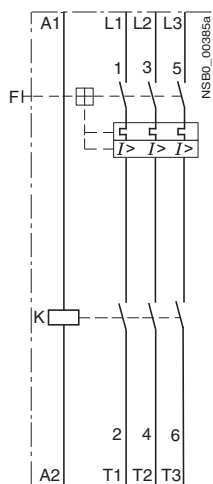

Reversing duty

Size S00

3RA12

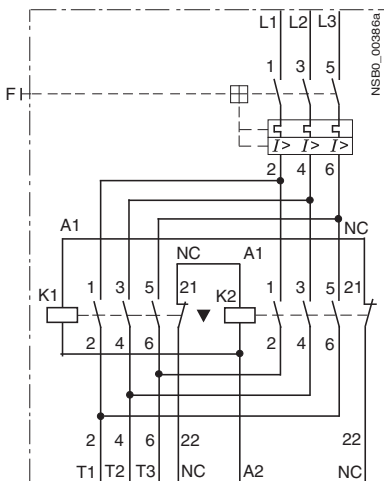

Size S0

3RA12

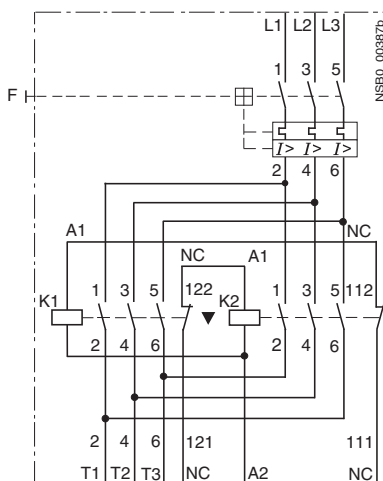

For Operation in the Control Cabinet

3RA6 Compact Feeders

General data

Overview

3RA6 fuseless compact feeders and infeed system for 3RA6

Integrated functionality

The SIRIUS 3RA6 compact feeders are a generation of innovative load feeders with the integrated functionality of a circuit breaker, contactor and solid-state overload relay. In addition, various functions of optional mountable accessories (e. g. auxiliary switches, surge suppressors) are already integrated in the SIRIUS compact feeder.

Application

The SIRIUS compact feeders can be used wherever standard induction motors up to 32 A (approx. 15 kW/400 V) are directly started.

Low equipment variance

Thanks to wide setting ranges for the rated current and wide voltage ranges, the equipment variance is greatly reduced compared to conventional load feeders.

Very high operational safety

No welding after a short-circuit release and defined shut-down when the end of service life is reached means that the SIRIUS compact feeder achieves a very high level of operational safety otherwise possible only with considerable additional outlay. This sets it apart from devices with similar functionality.

Safe disconnection

The auxiliary switches of the 3RA6 compact feeders are designed as mirror contacts. It is thus possible to use the devices for safe disconnection, e. g. emergency-stops, up to Category 2 (EN 954-1) and together with other redundancy switching devices up to Category 3 or 4.

Communications integration through AS-Interface

To enable communications integration through AS-Interface there is an AS-i add-on module (also available as a version with two local inputs for safe disconnection) which can be mounted instead of the control circuit terminals on the SIRIUS compact feeder.

The design of the AS-i add-on module permits a group of up to 62 feeders with a total of four cables to be connected to the control system. This reduces wiring work considerably compared to the parallel wiring method.

Permanent wiring / easy replacement

Using the SIRIUS infeed system for 3RA6 it is possible to carry out the wiring in advance without a compact feeder needing to be connected.

A compact feeder is very easily replaced simply by pulling it out of the device without disconnecting the wiring.

Even with screw connections or mounting on a standard mounting rail there is no need to disconnect any wiring (on account of the removable main and control circuit terminals) in order to replace a compact feeder.

Consistent solution from the infeed to the motor feeder

The SIRIUS infeed system for 3RA6 with integrated PE bar is offered as a user-friendly possibility of feeding in summation currents up to 100 A with a maximum conductor cross-section of 70 mm² and connecting the motor cable directly without additional intermediate terminals.

Screw and spring-type connections

The SIRIUS compact feeders and the SIRIUS infeed system for 3RA6 are available with screw and spring-type connections.



Screw connection



Spring-type connection

These connections are indicated in the Technical specifications by orange backgrounds.

System configurator for engineering

A free system configurator is available to reduce further the amount of engineering work for selecting the required compact feeders and matching infeed.

Types of infeed for the 3RA6 fuseless compact feeders

On the whole four different infeed possibilities are available:

- Parallel wiring
- Use of 3-phase busbars (combination with SIRIUS motor starter protectors and SIRIUS contactors possible)
- 8US busbar adapters
- SIRIUS infeed system for 3RA6

To comply with the clearance and creepage distances demanded according to UL 508 there are the following infeed possibilities:

Type of infeed	Feeder terminal (acc. to UL 508, type E)	Order No.
Parallel wiring	Terminal for "Self-Protected Combination Motor Controller (Type E)"	3RV19 28-1H
3-phase busbars	3-phase infeed terminal for constructing "Type E Starters", UL 508	3RV19 25-5EB
Infeed systems for 3RA6	Infeed on left, 50/70 mm ² , screw terminal with 3 sockets, outgoing terminal with screw/spring-type connections, including PE bar	3RA68 13-8AB (screw terminals), 3RA68 13-8AC (spring-type terminals)

SIRIUS 3RA6 compact feeders

The SIRIUS 3RA6 compact feeders are universal motor feeders according to IEC/EN 60947-6-2. As control and protective switching devices (CPS) they can connect, convey and disconnect the thermal, dynamic and electrical loads from short-circuit currents up to $I_q = 53$ kA, i. e. they are practically weld-free. They combine the functions of a motor starter protector, a contactor and a solid-state overload relay in a single enclosure and can be used wherever standard induction motors up to 32 A (up to approx. 15 kW at 400 V AC) are started directly. Direct-on-line and reversing starters are available as variants.

The reversing starter version comes with not only an internal electrical interlock but also with a mechanical interlock to prevent simultaneous actuation of both directions of rotation.

3RA6 fuseless compact feeders are available with 5 current setting ranges and 3 control voltage ranges:

For Operation in the Control Cabinet

3RA6 Compact Feeders

General data

Overall width of direct-on-line starter	Overall width of reversing starter	Current setting range	At 400 V AC for induction motors up to
mm	mm	A	kW
45	90	0.1 ... 0.4	0.09
45	90	0.32 ... 1.25	0.37
45	90	1 ... 4	1.5
45	90	3 ... 12	5.5
45	90	8 ... 32	15

The 3 control voltage ranges are:

- 24 V AC/DC
- 42 ... 70 V AC/DC
- 110 ... 240 V AC/DC

Note:

The 3RA1 load feeders can be used for fuseless load feeders > 32 A up to 100 A.

The SENTRON 3VL circuit breakers and the SIRIUS 3RT contactors can be used for fuseless load feeders > 100 A.

You will find related information in Chapter 16, Chapter 3 and Catalog LV 1.

Operating conditions

The SIRIUS 3RA6 compact feeders are suitable for use in any climate. They are intended for use in enclosed rooms in which no severe operating conditions (such as dust, caustic vapors, hazardous gases) prevail. Suitable covers must be provided for installation in dusty and damp locations.

The SIRIUS compact feeders are generally designed to degree of protection IP20. The permissible ambient temperature during operation is -20 ... +60 °C.

The operating short-circuit current is 53 kA at 400 V.

Note:

More technical specifications can be found in the system manual at

<http://www.siemens.com/compactstarter>

Overload tripping times

The overload tripping time can be set on the device to less than 10 s (CLASS 10) and less than 20 s (CLASS 20 for heavy starting). As the breaker mechanism still remains closed after an overload, resetting is possible by either local manual reset or autoreset after 3 minutes cooling time.

With autoreset there is no need to open the control cabinet.

Diagnostics options

The compact feeder provides the following diagnostics options:

- With LEDs:
 - Connection to the control voltage
 - Position of the main contacts
- With mechanical indication:
 - Tripping due to overload
 - Tripping due to short-circuit
 - Tripping due to malfunction (end of service life reached because of worn switching contacts or a worn switching mechanism or faults in the control electronics)

These states can be evaluated in addition in the higher-level control system by means of the integrated auxiliary switches and signal switches of the compact feeder.

Four complement variants for 3RA6 compact feeders

- For standard mounting rail or screw fixing: basic version including 1 pair of main circuit terminals and 1 pair of control circuit terminals
- For standard mounting rail or screw fixing when using the AS-i add-on module: without control circuit terminals because the AS-i add-on module is plugged on instead
- For use with the infeed system for 3RA6: without main circuit terminals because they are supplied with the infeed system and the expansion modules
- For use with the infeed system for 3RA6 and AS-i add-on module: without terminal complement (also for reordering when replacing the compact feeder)

For Operation in the Control Cabinet

3RA6 Compact Feeders

3RA61 direct-on-line starters,
3RA62 reversing starters, general data

Design

Mounting

The 3RA6 compact feeders can be fastened in 4 ways:

1) By snapping onto a TH 35 standard mounting rail

The SIRIUS compact feeders can be snapped onto a standard mounting rail according to EN 60715 with a width of 35 mm.

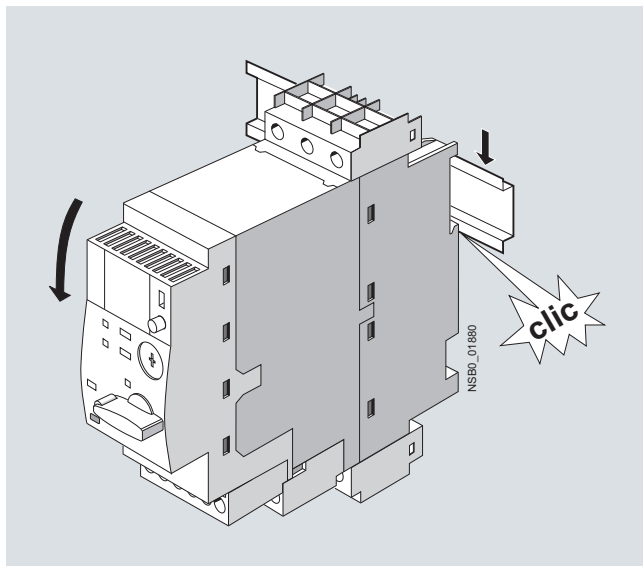

2) By screw fixing to a flat surface

The SIRIUS compact feeders are suitable for screw fixing to a flat surface. One set of 3RA69 40-0A adapters for screw connection (including push-in lugs) is required per direct-on-line starter, two sets are required per reversing starter.

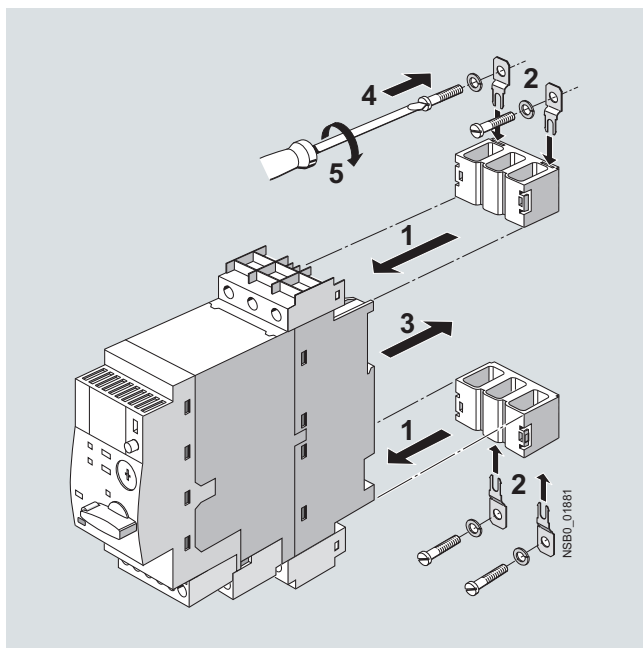

1 ... 5: order of mounting steps

3) By integrating in the infeed system for 3RA6

The SIRIUS compact feeders can be assembled with the infeed system for 3RA6 (see "Infeed system for 3RA6").

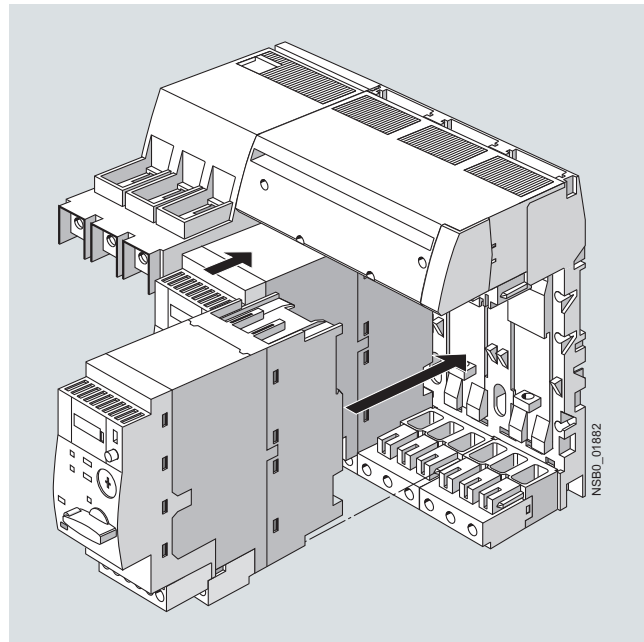

4) By using the 8US busbar adapter on busbar systems with 60 mm busbar center-to-center clearance

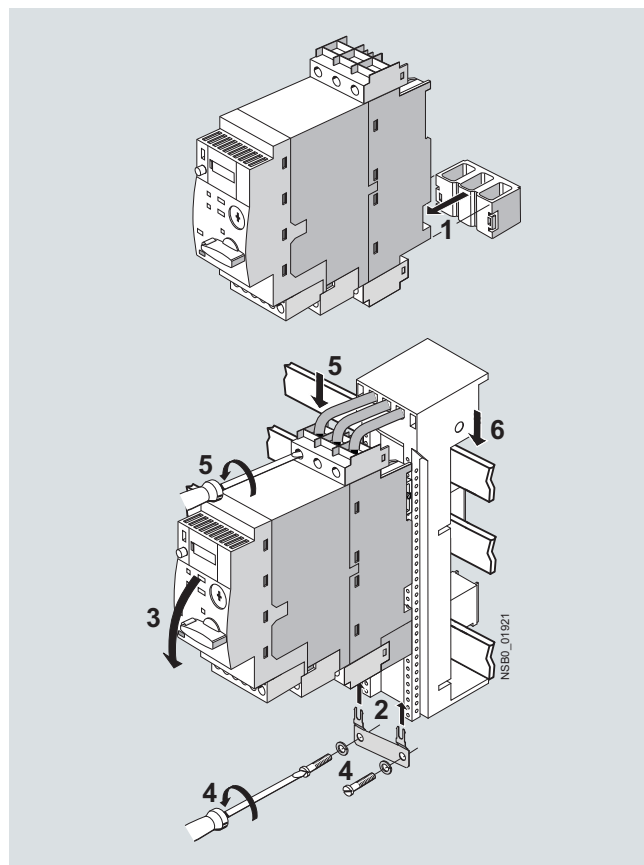

1 ... 6: order of mounting steps

For Operation in the Control Cabinet

3RA6 Compact Feeders

3RA61 direct-on-line starters,
3RA62 reversing starters, general data

4a) By using an additional device holder in the case of reversing starters

When the 8US busbar adapter is used on busbar systems with 60 mm busbar center-to-center clearance, a device holder is needed in addition for a reversing starter on account of its double width.

The reversing starter is mounted in the same way as the direct-on-line starter on the busbar adapter. Then the device holder is snapped on alongside the busbar adapter.

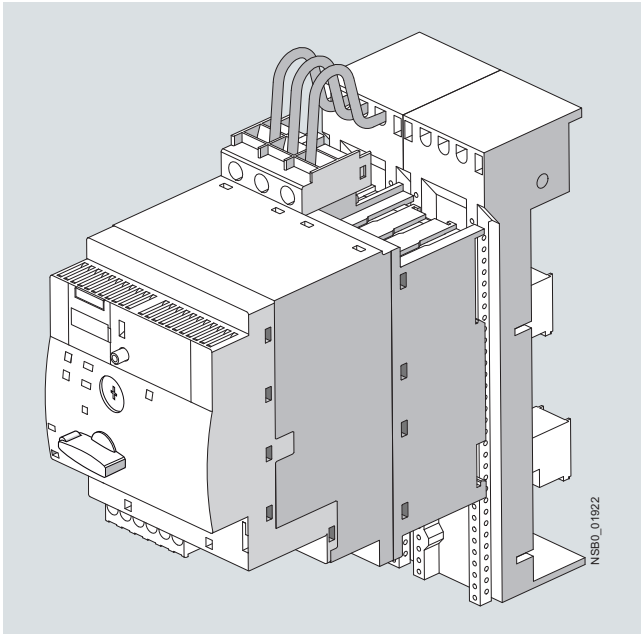

Mounting regulations

The module can be installed horizontally or vertically. For the different installations attention must be paid however to limit values for protective separation according to IEC/EN 60947-2 of the compact feeders (for details see the "Technical specifications").

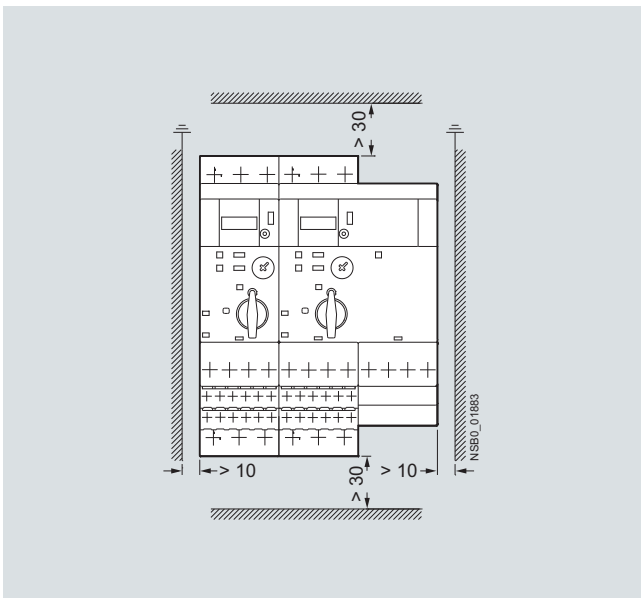

The following distances must be observed when mounting the compact feeders:

- Lateral clearance to grounded components: 10 mm
- Arcing space at top and bottom: 30 mm

For Operation in the Control Cabinet

3RA6 Compact Feeders

3RA61 direct-on-line starters,
3RA62 reversing starters, general data

Function

Trip units

The SIRIUS 3RA6 compact feeders are equipped with the following trip units:

- Inverse-time delayed solid-state overload release
- Instantaneous electronic trip unit (electromagnetic short-circuit release)

The overload releases can be adjusted in accordance with the load current.

The electronic trip units are permanently set to a value 13 times the maximum rated current of the 4 A, 12 A and 32 A feeder and thus enable trouble-free starting of motors.

Trip classes

The trip classes of electronically delayed trip units are based on the tripping time (t_A) at 7.2 times the set current in the cold state (excerpt from IEC 60947-4):

CLASS 10: $4s < t_A < 10s$

CLASS 20: $6s < t_A < 20s$ (for heavy starting)

The compact feeder must trip within this time.

Disconnection due to malfunction

The following malfunctions can be detected:

- End of service life
 - Worn switching contacts (for electrical endurance see "Technical specifications")
 - Worn switching mechanisms (for mechanical endurance see "Technical specifications")
- Faults in the control electronics

Short-circuit protection

If a short-circuit occurs, the short-circuit releases of the SIRIUS 3RA6 compact feeders isolate the faulty load feeder from the network and thus prevent further damage. The short-circuit releases are factory-set to 14 times the value of the maximum rated current I_n of the device.

The SIRIUS compact feeders have a short-circuit breaking capacity of 53 kA at a voltage of 400 V AC. Higher short-circuit currents are not to be expected in practice.

Overload relay function

In the event of an overload, the compact feeder switches off without the breaker mechanism being opened.

The overload trip can be signaled to the higher-level control system through an integrated signal switch (1 W).

The overload signal can be reset automatically or by means of a manual reset.

Control through AS-Interface

For control through AS-Interface, the AS-i add-on module is mounted instead of the two control circuit terminals on the SIRIUS 3RA6 compact feeders (direct-on-line starters and reversing starters).

The AS-i auxiliary voltage and the AS-i data line are installed on the AS-i add-on module easily and quickly without tools by means of two plug-in connector blocks with insulation displacement connection.

The AS-i add-on module is equipped with the latest A/B technology and has an addressing socket onboard.

An addressing unit can be ordered for addressing the AS-i add-on module.

Bit assignment (see below) is similar to that for the SIRIUS motor starters, which means that the same programming can be used here.

DI 0.0 ready
DI 0.1 motor on
DI 0.2 group fault
DI 0.3 group warning

DO 0.0 motor on or motor clockwise
DO 0.1 motor counterclockwise

A 24 V DC PELV power supply unit according to EN 61140 safety class III is required for the auxiliary voltage.

The AS-i data line is supplied with voltage by means of an AS-i power supply unit and is controlled by means of the AS-i master.

The AS-i add-on modules are available in the following two versions:

- AS-i add-on modules for compact feeders
- AS-i add-on modules for compact feeders with two local inputs for safe disconnection of the "clockwise rotation" or "counterclockwise rotation" outputs

The AS-i add-on module can be combined only with compact feeders with a control voltage of 24 V AC/DC.

Integrated auxiliary switches

The control circuit terminals of the SIRIUS 3RA6 compact feeders have the following connections:

- A1/A2 for the control voltage for 3RA61, A1/A2 and B1/B2 for the control voltage for 3RA62
- "Overload" signal switch
- "Fault" signal switch, e. g. "short-circuit"
- Internal auxiliary switch for position of the main contacts (in case of direct-on-line starters: 1 NO + 1 NC with mirror contact to the main contact; in case of reversing starters: 2 NO)

For Operation in the Control Cabinet

3RA6 Compact Feeders

3RA61 direct-on-line starters,
3RA62 reversing starters, general data

Technical specifications

Type			3RA61	3RA62
Size			S0	
Number of poles			3	
General data				
Device standard			IEC/EN 60947-6-2	
Max. rated current $I_{n\max}$ (= max. rated operational current I_e) for the respective setting range	0.1 ... 0.4 A	A	0.4	
	0.32 ... 1.25 A	A	1.25	
	1 ... 4 A	A	4	
	4 ... 12 A	A	12	
	8 ... 32 A	A	32	
Permissible ambient temperature				
• During operation	Acc. to IEC/EN 60721-3-3	°C	-20 ... +60, with restriction up to +70	
• For installation in SIRIUS infeed system for 3RA6		°C	-20 ... +40	
• During storage	IEC/EN 60732-3-1	°C	-55 ... +80	
• During transport	IEC/EN 60721-3-2	°C	-55 ... +80	
Permissible rated current of the compact feeder, when several compact feeders are mounted side-by-side on a vertical standard mounting rail or in the infeed system for 3RA6				
• For a control cabinet inside temperature of	+40 °C	%	100	
• For a control cabinet inside temperature of	+60 °C	%	80	
Relative air humidity		%	10 ... 90	
Installation altitude		m	Up to 2000 above sea level without restriction	
Rated frequency		Hz	50/60	
Rated insulation voltage U_i (degree of pollution 3)		V	690	
Rated impulse withstand voltage U_{imp}		kV	6	
Trip class (CLASS)	Acc. to IEC 60947-4-1, EN 60947-4-1		10/20	
Rated short-circuit current I_q at AC 50/60 Hz 400 V	Acc. to IEC 60947-4-1, EN 60947-4-1	kA	53 kA	
Types of coordination	Acc. to IEC 60947-6-2, EN 60947-6-2		Continuously	
Power loss $P_{v\max}$ of all main current paths Dependent on the rated current I_n (upper setting range)	Up to 0.4 A	mW	2	
	0.32 ... 1.25 A	mW	19.1	
	1 ... 4 A	W	0.2	
	3 ... 12 A	W	0.7	
	8 ... 32 A	W	2.3	
Compact feeder endurance				
• Mechanical endurance		Oper- ating cycles	10 000 000	
• Electrical endurance	At $I_e = 0.9 I_n$	Oper- ating cycles	1 520 000	
Max. switching frequency	AC-41	1/h	750	
	AC-43	1/h	250	
	AC-44	1/h	15	
Drive losses				
Active power	At 24 V			
	• Up to 12 A	W	2.7	
	• 8 ... 32 A	W	2.95	
	At 42 ... 70 V			
	• Up to 12 A	W	2.5	
	• 8 ... 32 A	W	3.0	
	At 110 ... 240 V			
	• Up to 12 A	W	3.4	
	• 8 ... 32 A	W	3.8	
Overload function				
Ratio of lower to upper current mark			1:4	
Shock resistance (sine-wave pulse)			$a = 60 \text{ m/s}^2 = 6g$ with 10 ms; for every 3 shocks in all axes	
Vibratory load			$f = 1 \dots 6 \text{ Hz}$; $d = 15 \text{ mm}$ 10 cycles $f = 150 \text{ Hz}$; $a = 2g$	
Degree of protection	Acc. to IEC 60947-1		IP20	
Touch protection	Acc. to IEC/EN 61140		Finger-safe	
Isolating features of the compact feeder	Acc. to IEC/EN 60947-3		Yes	
Main and EMERGENCY-STOP switch characteristics of the compact feeder and accessories	Acc. to IEC/EN 60204		Yes	

For Operation in the Control Cabinet

3RA6 Compact Feeders

3RA61 direct-on-line starters, 3RA62 reversing starters, general data

Type			3RA61	3RA62
Size			S0	
Number of poles			3	
General data				
Protective separation	Acc. to IEC 60947-2			
Control circuit to auxiliary circuit				
• Horizontal standard mounting rail		V	Up to 400	
• Other mounting position		V	Up to 250	
Auxiliary circuit to auxiliary circuit				
• Horizontal standard mounting rail		V	Up to 400	
• Other mounting position		V	Up to 250	
Main circuit to auxiliary circuit				
• Any mounting position		V	Up to 400	
EMC interference immunity	Acc. to IEC 60947-1			Corresponds to degree of severity 3
Conductor-related interference	BURST acc. to IEC 61000-4-4	kV	4	
Conductor-related interference	SURGE acc. to IEC 61000-4-5			
• Conductor - Ground		kV	4	
• Conductor - Conductor		kV	1	
Electrostatic discharge	Acc. to IEC 61000-4-2	kV	8	
ESD		kV	6	
Field-related interference	Acc. to IEC 61000-4-3	V/m	10	
Auxiliary switches				
• Integrated			2 NO, 1 NC, 1 CO	3 NO, 1 CO
• Expandable			1 x auxiliary switch	1 x auxiliary switch per direction of rotation
			2 NO, 2 NC, 1 NO + 1 NC	2 NO, 2 NC, 1 NO + 1 NC
Surge suppressors			Integrated (Varistor)	
Degree of pollution			3	
Depth from standard mounting rail		mm	160	
Electromagnetic operating mechanism				
Control voltage		V	24 AC/DC	
		V	42 ... 70 AC/DC	
		V	110 ... 240 AC/DC	
Frequency	At AC	Hz	50/60 (±5%)	
Operating range			0.7 ... 1.25 U_s	
No-load switching frequency		1/h	3600	
Make-time		ms	Max. 70	
Break-time		ms	Max. 120	
Max. pick-up current at 24 V DC	At 12 A	mA	250	
	At 32 A	mA	350	
Max. hold current at 24 V DC	At 12 A	mA	100	
	At 32 A	mA	150	
Max. pick-up power at 24 V DC	At 12 A	W	6.0	
	At 32 A	W	8.4	
Max. hold power at 24 V DC	At 12 A	W	2.4	
	At 32 A	W	3.6	
Hold current and hold power valid for 24 V operating range				
	24 V, AC operation			
	• Up to 12 A			
Hold current		mA	132	
Active power		W	2.7	
Apparent power		VA	3.15	
P.f.			0.86	
	• 8 ... 32 A			
Hold current		mA	144	
Active power		W	3.0	
Apparent power		VA	3.45	
P.f.			0.86	
	24 V, DC operation			
	• Up to 12 A			
Hold current		mA	100	
Active power		W	2.45	
Apparent power		VA	2.75	
P.f.			0.88	
	• 8 ... 32 A			
Hold current		mA	116	
Active power		W	2.8	
Apparent power		VA	3.3	
P.f.			0.85	

For Operation in the Control Cabinet

3RA6 Compact Feeders

3RA61 direct-on-line starters,
3RA62 reversing starters, general data

Type		3RA61	3RA62
Size		S0	
Number of poles		3	
Electromagnetic operating mechanism			
Hold current and hold power valid for operating range 42 V ... 70 V			
	42 V, AC operation • Up to 12 A		
Hold current		mA	75
Active power		W	2.35
Apparent power		VA	3.2
P.f.			0.734
	• 8 ... 32 A		
Hold current		mA	84
Active power		W	2.7
Apparent power		VA	3.6
P.f.			0.73
	42 V, DC operation • Up to 12 A		
Hold current		mA	55
Active power		W	2.3
Apparent power		VA	2.7
P.f.			0.853
	• 8 ... 32 A		
Hold current		mA	63
Active power		W	2.7
Apparent power		VA	3.35
P.f.			0.85
	70 V, AC operation • Up to 12 A		
Hold current		mA	54
Active power		W	2.5
Apparent power		VA	3.8
P.f.			0.654
	• 8 ... 32 A		
Hold current		mA	58.5
Active power		W	2.7
Apparent power		VA	4
P.f.			0.65
	70 V, DC operation • Up to 12 A		
Hold current		mA	33
Active power		W	2.35
Apparent power		VA	2.9
P.f.			0.813
	• 8 ... 32 A		
Hold current		mA	37
Active power		W	2.6
Apparent power		VA	3.0
P.f.			0.81
Hold current and hold power valid for operating range 110 V ... 240 V			
	110 V, AC operation • Up to 12 A		
Hold current		mA	38
Active power		W	2.8
Apparent power		VA	4.2
P.f.			0.67
	• 8 ... 32 A		
Hold current		mA	42.5
Active power		W	3.2
Apparent power		VA	4.7
P.f.			0.68
	110 V, DC operation • Up to 12 A		
Hold current		mA	22.5
Active power		W	2.5
Apparent power		VA	3.75
P.f.			0.67
	• 8 ... 32 A		
Hold current		mA	25.5
Active power		W	2.9
Apparent power		VA	4.65
P.f.			0.62
	240 V, AC operation • Up to 12 A		
Hold current		mA	36
Active power		W	3.6
Apparent power		VA	8.8
P.f.			0.41
	• 8 ... 32 A		
Hold current		mA	39
Active power		W	3.9
Apparent power		VA	9.3
P.f.			0.42

For Operation in the Control Cabinet

3RA6 Compact Feeders

3RA61 direct-on-line starters, 3RA62 reversing starters, general data

Type		3RA61	3RA62
Size		S0	
Number of poles		3	
Electromagnetic operating mechanism			
Hold current and hold power valid for operating range 110 V ... 240 V			
	240 V, DC operation		
	• Up to 12 A		
Hold current		mA	12.5
Active power		W	3.0
Apparent power		VA	6.35
P.f.			0.47
	• 8 ... 32 A		
Hold current		mA	14
Active power		W	3.35
Apparent power		VA	6.55
P.f.			0.51
Switching capacity at 400 V		kA	53
Switching capacity at 690 V		kA	3
Line protection			
	At 10 kA	mm ²	2.5
	At 50 kA	mm ²	4
Shock resistance			
• Breaker mechanism OFF		g	25
• Breaker mechanism ON		g	15
Normal switching duty			
Making capacity			12 × I _n
Breaking capacity			10 × I _n
Switching capacity dependent on rated current			
	Up to 12 A	kW	5.5
	Up to 32 A	kW	15
Endurance in operating cycles			
• Mechanical endurance			10 000 000
• Electrical endurance		At I _e = 0.9 × I _n	1 520 000

Type		3RA61	3RA62
Size		S0	
Number of poles		3	
Control circuit			
Rated operational voltage			
• External auxiliary switch block		V	400/690
• Internal auxiliary switch		V	400/690
• Short-circuit signal switch		V	400
• Overload signal switch		V	400
Switching capacity			
• External auxiliary switch block			
	AC-15		
	• At U _e = 230 V	A	6
	• At U _e = 400 V	A	3
	• At U _e = 289/500 V	A	2
	• At U _e = 400/690 V	A	1
	DC-13		
	• At U _e = 24 V	A	6
	• At U _e = 60 V	A	0.9
	• At U _e = 125 V	A	0.55
	• At U _e = 250 V	A	0.27
• Internal auxiliary switch			
	AC-15		
	• At U _e = 230 V	A	6
	• At U _e = 400 V	A	3
	• At U _e = 289/500 V	A	2
	• At U _e = 400/690 V	A	1
	DC-13		
	• At U _e = 24 V	A	10
	• At U _e = 60 V	A	2
	• At U _e = 125 V	A	1
	• At U _e = 250 V	A	0.27
	• At U _e = 480 V	A	0.1
• Signal switch			
	AC-15		
	• At U _e = 230 V	A	3
	• At U _e = 400 V	A	1
	DC-13		
	• At U _e = 24 V	A	2
	• At U _e = 250 V	A	0.11

For Operation in the Control Cabinet

3RA6 Compact Feeders

3RA61 direct-on-line starters,
3RA62 reversing starters, general data

Type			3RA61	3RA62
Size			S0	
Number of poles			3	
External auxiliary switch block, internal auxiliary switch				
Endurance in operating cycles				
• Mechanical endurance			10 000 000	
• Electrical endurance	AC-15, 230 V		200 000	
	• At 6 A		500 000	
	• At 3 A		2 000 000	
	• At 0.3 A		10 000 000	
	DC-13, 24 V			
	• At 6 A		30 000	
	• At 3 A		100 000	
	• At 0.5 A		2 000 000	
	• At 0.2 A		10 000 000	
	DC-13, 110 V			
	• At 1 A		40 000	
	• At 0.55 A		100 000	
	• At 0.3 A		300 000	
	• At 0.1 A		2 000 000	
	• At 0.04 A		10 000 000	
	DC-13, 220 V			
	• At 0.3 A		110 000	
	• At 0.1 A		650 000	
	• At 0.05 A		2 000 000	
	• At 0.018 A		10 000 000	
Contact stability	At 17 V and 5 mA	Operating cycles	1 incorrect switching operation per 100 000 000	
Short-circuit protection				
• Short-circuit current $I_K \leq 1.1$ kA	Fuse links gL/gG NEOZED 5SE, DIAZED 5SB, LV HRC 3NA	A	10	
• Short-circuit current $I_K < 400$ A	Miniature circuit breaker up to 230 V with C characteristic	A	10	
Signal switches				
Endurance in operating cycles				
• Mechanical endurance			20 000	
• Electrical endurance AC-15	At 230 V and 3 A		6050	
Contact stability	At 17 V and 5 mA	Operating cycles	1 incorrect switching operation per 100 000 000	
Short-circuit protection				
• Short-circuit current $I_K \leq 1.1$ kA	Fuse links gL/gG NEOZED 5SE, DIAZED 5SB, LV HRC 3NA	A	6	
• Short-circuit current $I_K < 400$ A	Miniature circuit breaker up to 230 V with C characteristic	A	6	
Overload (short-circuit current $I_K \leq 1.1$ kA)	Fuse links gL/gG NEOZED 5SE, DIAZED 5SB, LV HRC 3NA	A	4	

Dimensional drawings

Direct-on-line starters and reversing starters

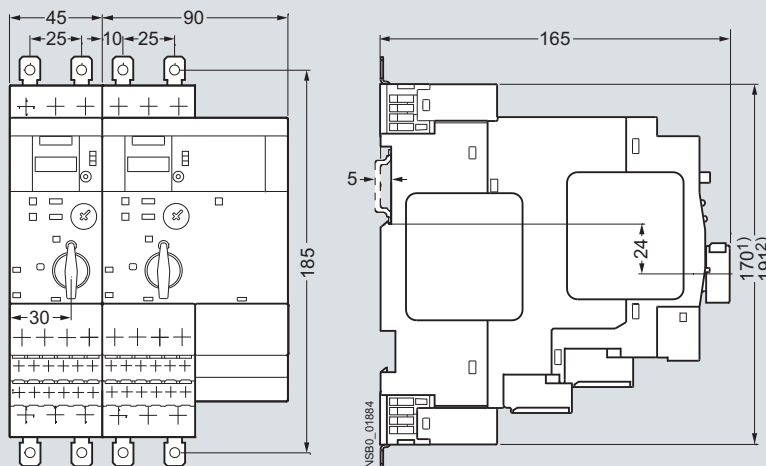

- 1) Screw connection
2) Spring-loaded connection

For Operation in the Control Cabinet

3RA6 Compact Feeders

3RA61 direct-on-line starters,
3RA62 reversing starters, general data

Schematics

3RA61 direct-on-line starters

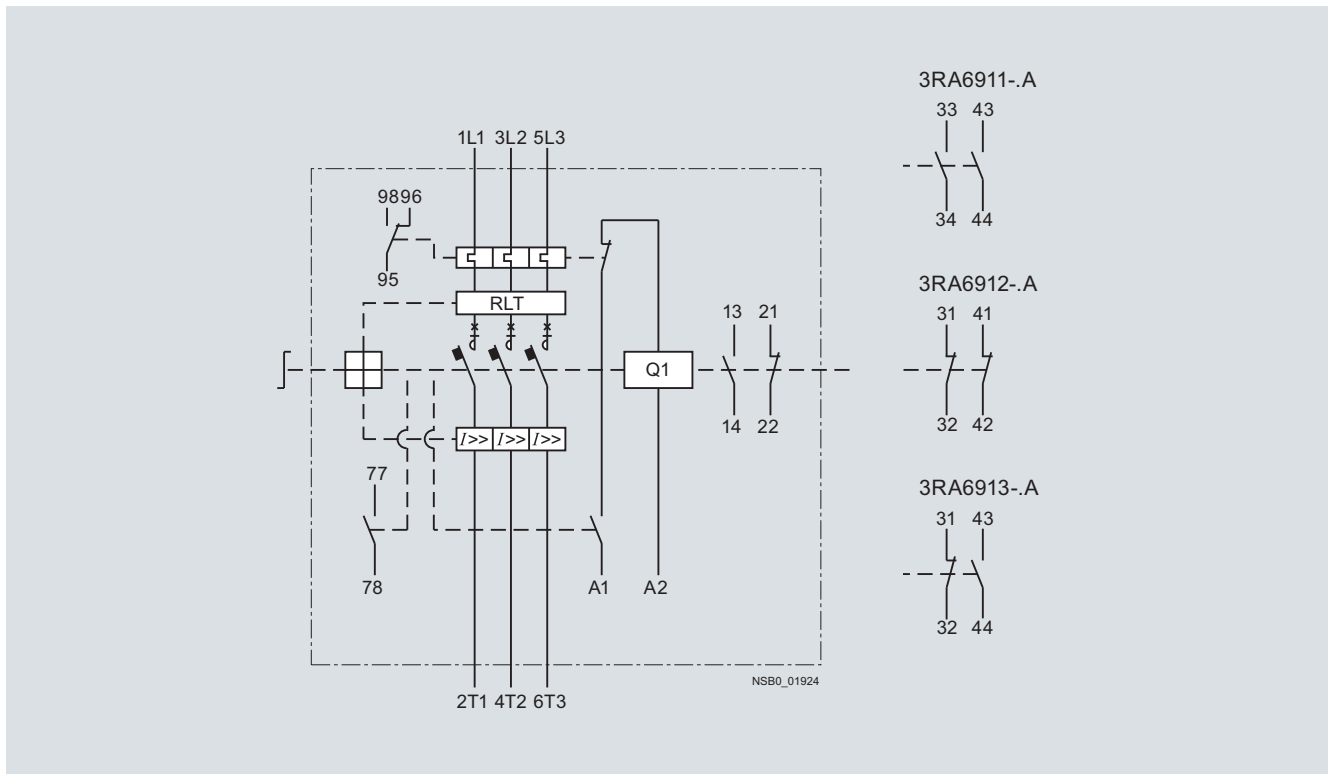

Schematic for 3RA61 direct-on-line starters (main circuit)

For Operation in the Control Cabinet

3RA6 Compact Feeders

3RA61 direct-on-line starters,
3RA62 reversing starters, general data

3RA62 reversing starters

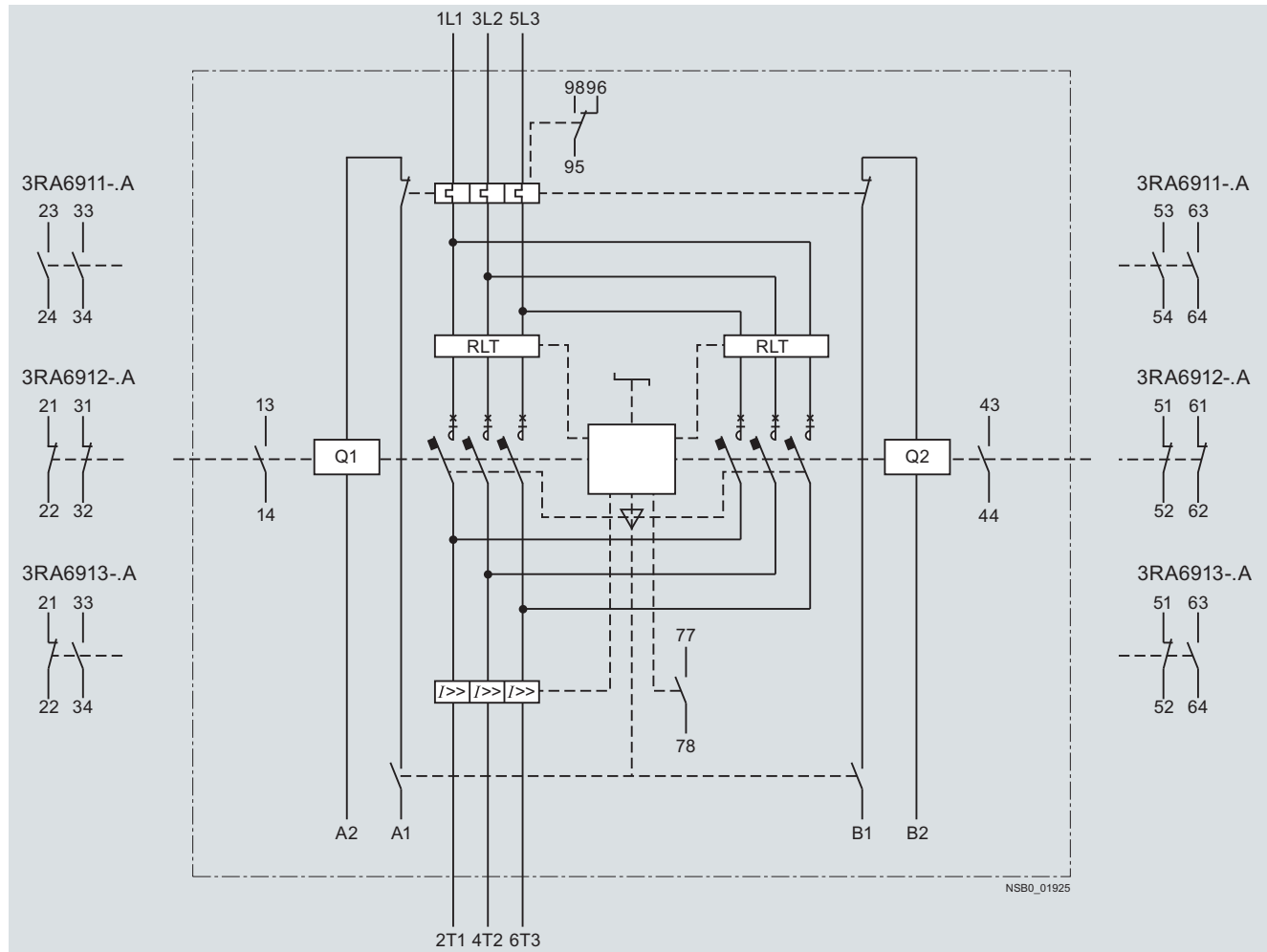

Schematic for 3RA62 reversing starters (main circuit)

For Operation in the Control Cabinet

3RA6 Compact Feeders

Accessories for 3RA6 direct-on-line and reversing starters

Overview

Accessories for SIRIUS 3RA6 compact feeders

The following accessories are available specially for the 3RA6 compact feeders:

- AS-i add-on module: For communication of the compact feeder with the control system using AS-Interface; also available as a version with two local inputs for safe disconnection. The AS-i add-on module can be combined only in connection with compact feeders with a rated control supply voltage of 24 V AC/DC.
- Addressing unit for addressing the AS-i add-on module
- External auxiliary switch blocks: Snap-on auxiliary switch as versions 2 NO, 2 NC and 1 NO + 1 NC with screw or spring-type connections; the contacts of the auxiliary switch block open and close jointly with the main contacts of the compact feeder. The NC contacts are designed as mirror contacts.
- Control kit: aid for manually closing the main contacts in order to check the wiring and motor direction under conditions of short-circuit protection
- Adapter for screw fixing the compact feeder, including push-in lugs
- Main conductor terminal: available with screw and spring-type connection

Accessories for parallel wiring

The terminal block for "Self-Protected Combination Motor Controller", type E is available for complying with the clearance and creepage distances demanded according to UL 508.

Accessories for infeed using 3-phase busbar systems

The 3-phase busbars can be used as an easy, time-saving and clearly arranged means of feeding SIRIUS 3RA6 compact feeders with screw connection. Motor starter protector sizes S00 and S0 can also be integrated.

The busbars are suitable for between 2 and 5 devices. However, any kind of extension up to a maximum summation current of 63 A is possible by clamping the tags of an additional busbar (rotated by 180°) underneath the terminals of the respective last circuit breaker.

A connecting piece is required for the combination with motor starter protector size S00. The motor starter protectors are supplied by appropriate feeder terminals. Special feeder terminals are required for constructing "Type E Starters" according to UL/CSA.

The 3-phase busbar systems are finger-safe but empty connection tags must be fitted with covers. They are designed for any short-circuit stress which can occur at the output side of connected SIRIUS 3RA6 compact feeders or motor starter protectors.

Busbar adapters for 60 mm systems

The compact feeders are mounted directly with the aid of busbar adapters on busbar systems with 60 mm center-to-center clearance in order to save space and to reduce infeed times and costs. These feeders are suitable for copper busbars with a width from 12 to 30 mm. The busbars can be 4 to 5 mm or 10 mm thick.

The 8US busbar system can be loaded with a maximum summation current of 630 A.

The "reversing starter" version requires a device holder along side the busbar adapter for lateral mounting.

The compact feeders are snapped onto the adapter and connected on the line side. This prepared unit is then plugged directly onto the busbar system, and is thus connected both mechanically and electrically at the same time.

For more accessories such as incoming and outgoing terminals, flat copper profiles etc., see LV1, Chapter 14, "8US Busbar Systems, 60 mm Busbar System".

Accessories for operation with closed control cabinet doors

Door-coupling rotary operating mechanisms for standard and emergency-stop applications are available for operating the compact feeder with closed control cabinet doors.

For Operation in the Control Cabinet

3RA6 Compact Feeders

Accessories
for 3RA6 direct-on-line and reversing starters

Technical specifications

Connection type	Screw connection		Spring-type connection	
	12 A	32 A	12 A	32 A
Max. rated current I_{max}				
Conductor cross-sections of main circuit terminals				
Tools	Pozidriv size 2		(3.5 x 0.5) mm, 8WA2 803	
Prescribed tightening torque	NM	2 ... 2.5	--	
Minimum/maximum conductor cross-sections				
• Solid	mm ² mm ² mm ²	2 x (1.5 ... 2.5) 2 x (2.5 ... 6) Max. 1 x 10	2 x (2.5 ... 6) Max. 1 x 10	2 x (1.5 ... 6) Max. 1 x 10 2 x (2.5 ... 6) Max. 1 x 10
• Finely stranded without end sleeve	mm ²	--	--	2 x (1.5 ... 6) 2 x (2.5 ... 6)
• Finely stranded with end sleeve	mm ² mm ²	2 x (1.5 ... 2.5) 2 x (2.5 ... 6)	2 x (2.5 ... 6)	2 x (1.5 ... 6) 2 x (2.5 ... 6)
• AWG cables	AWG AWG AWG	2 x (16 ... 14) 2 x (14 ... 10) 1 x 8	2 x (14 ... 10) 1 x 8	2 x (16 ... 10) 1 x 8 2 x (14 ... 10) 1 x 8

Connection type	Screw connection		Spring-type connection	
	12 A	32 A	12 A	32 A
Conductor cross-sections of control circuit terminals				
Tools	Pozidriv size 2		(3.0 x 0.5) mm, DIN ISO 2380-1A	
Prescribed tightening torque	NM	0.8 ... 1.2	--	
Minimum/maximum conductor cross-sections				
• Solid	mm ² mm ²	1 x (0.5 ... 4) 2 x (0.5 ... 2.5)		2 x (0.25 ... 1.5)
• Finely stranded without end sleeve	mm ²	--		2 x (0.25 ... 1.5)
• Finely stranded with end sleeve	mm ² mm ²	1 x (0.5 ... 2.5) 2 x (0.5 ... 1.5)		2 x (0.25 ... 1.5)
• AWG cables	AWG	2 x (20 ... 14)		2 x (24 ... 16)
Conductor cross-sections of the auxiliary switch for compact feeders				
Order No.	3RA69 1.-1A		3RA69 1.-2A	
Tools	Pozidriv size 2		(2.5 x 0.4) mm, 8WA2 807	
Prescribed tightening torque	NM	0.8 ... 1.2	--	
Conductor cross-sections				
• Solid	mm ² mm ² mm ²	2 x (0.5 ... 1.5) 2 x (0.75 ... 2.5) 2 x (1 ... 4)		2 x (0.25 ... 2.5)
• Finely stranded without end sleeve	mm ²	--		2 x (0.25 ... 2.5)
• Finely stranded with end sleeve	mm ² mm ²	2 x (0.5 ... 1.5) 2 x (0.75 ... 2.5)		2 x (0.25 ... 1.5)
• AWG cables	AWG AWG AWG	2 x (20 ... 16) 2 x (18 ... 14) 1 x 12		2 x (24 ... 14)

For Operation in the Control Cabinet

3RA6 Compact Feeders

Accessories for 3RA6 direct-on-line and reversing starters

Order No.	3RA6970-3A, 3RA6970-3B,		
General data of the AS-i add-on module			
Permissible ambient temperature			
• Storage	Acc. to IEC/EN 60721-3-1	°C	-25 ... +70
• Transport	Acc. to IEC/EN 60721-3-2	°C	-25 ... +70
Degree of protection	Acc. to IEC/EN 60947-1		IP20
EMC interference immunity	Acc. to EN 50295		
Conductor-related interference	BURST acc. to IEC/EN 61000-4-4	kV	1/2
Electrostatic discharge	Acc. to IEC/EN 61000-4-2	kV	6/8
Field-related interference	Acc. to IEC/EN 61000-4-3	V/m	10 (80 MHz ... 2.7 GHz)
Maximum pick-up current		mA	400
Maximum hold current		mA	200
Power consumption, max.		mA	30
IO code			7
ID code			A
ID2 code			E

Order No.	3RA6970-3B		
Connection type	 Screw connection		
Conductor cross-sections of the AS-i add-on module			
Tools			Pozidriv size 1
Prescribed tightening torque		NM	0.5 ... 0.6
Conductor cross-sections			
• Solid		mm ²	1 x (0.5 ... 2.5)
		mm ²	2 x (0.5 ... 1.0)
• Finely stranded with end sleeve		mm ²	1 x (0.5 ... 2.5)
		mm ²	2 x (0.5 ... 1.0)
• AWG cables		AWG	1 x (20 ... 12)

For Operation in the Control Cabinet

3RA6 Compact Feeders

Infeed systems for 3RA6

Overview

The infeed system for 3RA6 compact feeders enables far less wiring in the main circuit and, thanks to the easy exchangeability of the compact feeders, reduces the usual downtimes for maintenance work during the plant's operating phase.

The infeed system provides the possibility of completely prewiring the main circuit without a compact feeder needing to be connected at the same time. As the result of the removable terminals in the main circuit, compact feeders can be integrated in an in-feed system in easy manner (without the use of tools).

In addition, the integrated PE bar means it is optionally possible to connect the motor cable directly to the infeed system without additional intermediate terminals. The infeed system for 3RA6 compact feeders is designed for summation currents up to 100 A with a maximum conductor cross-section of max. 70 mm² on the feeder terminal block.

The infeed system can be mounted on a standard mounting rail or flat surfaces.

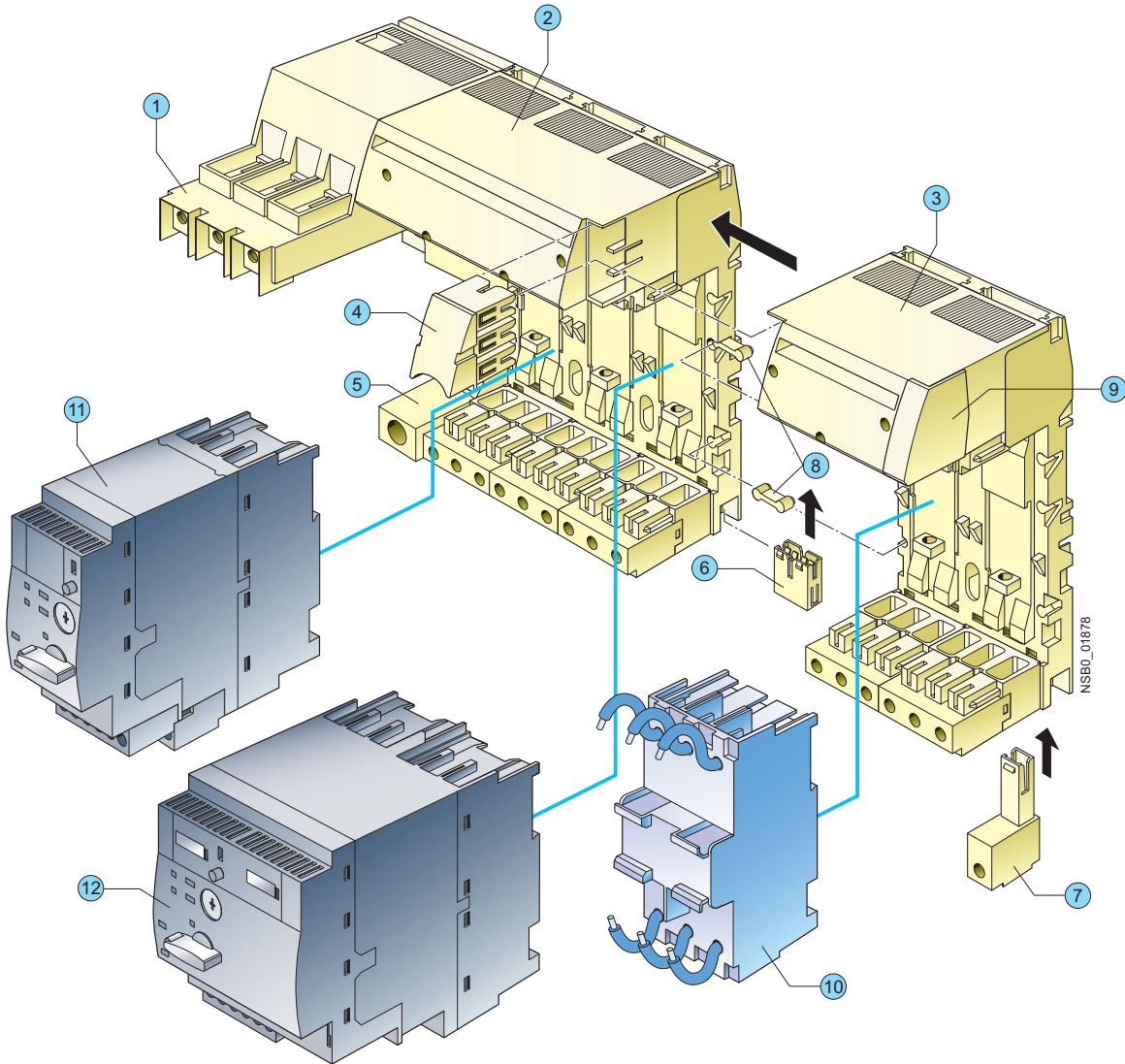

- ① Feeder terminal
- ② Three-socket expansion module
- ③ Two-socket expansion module
- ④ Expansion plug
- ⑤ PE infeed
- ⑥ PE expansion plug

- ⑦ PE pick-off
- ⑧ Connecting plate
- ⑨ End cover
- ⑩ 45 mm adapter for SIRIUS motor starter protector size S0
- ⑪ 3RA61 direct-on-line starter
- ⑫ 3RA62 reversing starter

For Operation in the Control Cabinet

3RA6 Compact Feeders

Infeed systems for 3RA6

① Infeed

The 3-phase infeed is available with screw connection (25/35 mm² up to 63 A or 50/70 mm² up to 100 A) and spring-type connection (25/35 mm² up to 63 A).

The infeed with spring-type terminal can be fitted on the left as well on as the right to an expansion module.

The infeed with screw terminal is supplied only with a 3-socket expansion module and permanently fitted on the left side.

The infeeds with screw connection enable connection of the main conductors (L1, L2, L3) either from above or from below.

The infeed with screw connection is supplied complete with 1 end cover, the infeed with spring-type connection complete with 2 end covers.

② Three-socket expansion modules

The expansion module with 3 sockets for compact feeders is available with screw connection and with spring-type connection.

Expansion modules enable the infeed system to be expanded and can be fitted to each other in any number.

Two expansion modules are held together with the help of 2 connecting plates and 1 expansion plug. These assembly parts are included in the scope of supply of the respective expansion module.

When the infeed system for 3RA6 is used, the compact feeders (plug-in modules) are easily mounted and removed even when live.

Optional possibilities:

- PE connection on motor outgoing side
- Outfeed for external auxiliary devices
- Connection to 3RV19 infeed system
- Integration of SIRIUS motor starter protectors size S00 and S0 (using 3RA68 90-0BA adapter)

③ Two-socket expansion modules

If only 2 instead of 3 additional sockets are required, then the 2-socket expansion module is the right choice. It has the same functionality as the 3-socket expansion module.

④ Expansion plug

Two expansion modules can be connected together using the expansion plug. Flexible expansion of the infeed system is thus possible.

⑤ PE infeeds

This module enables a PE cable to be connected.

The PE infeed can be ordered with screw connection and spring-type connection (35 mm²) and can be fitted on the right or left to the expansion block.

⑥ PE expansion plug

The PE expansion plug is inserted from below and enables two PE bars to be connected.

⑦ PE pick-off

The PE pick-off is available with screw connection and spring-type connection (6/10 mm²). It is snapped into the infeed system from below.

⑧ Connecting plates

Two connecting plates are used to hold together 2 expansion modules.

⑨ End covers

On the last expansion module of a row, the socket provided for the expansion plug can be covered by inserting the end cover.

⑩ 45 mm adapters for SIRIUS motor starter protectors

SIRIUS motor starter protectors size S0 with screw connection can be fitted to the adapter, enabling them to be plugged into the infeed system.

Terminal blocks

Using the terminal block the 3 phases can be fed out of the system; this means that single-phase, 2-phase and 3-phase components can also be integrated in the system.

After the end cover is pulled out, the terminal block can be plugged onto an expansion module.

Expansion plug for SIRIUS 3RV19 infeed systems

After the end cover is pulled out, the expansion plug for the SIRIUS 3RV19 infeed system can be plugged onto an expansion module. It connects the infeed system for 3RA6 with the SIRIUS 3RV19 infeed system.

Maximum rated operational current

The following maximum rated operational currents apply for the components of the infeed system for 3RA6:

Component	Maximum rated operational current A
Infeed with screw connection 50/70 mm ²	100
Infeed with screw connection 25/35 mm ²	63
Infeed with spring-type connection 25/35 mm ²	63
Expansion plug	63

In a row of several expansion modules, the maximum rated operational current from the 2nd expansion module to the end of the row is 63 A.

Proposal for upstream short-circuit protection devices

The following short-circuit data apply for the components of the infeed system for 3RA6:

Conductor cross-section mm ²	Inscriptions	Proposal for upstream short-circuit protection device
Short-circuit protection for infeed block (25 mm²/35 mm²) with screw connection		
2.5 ... 35	$I_{d,max} = 19 \text{ kA}$, $I^2t = 440 \text{ kA}^2\text{s}$	3RV10 41-4JA10
Short-circuit protection for infeed block (50 mm²/70 mm²) with screw connection		
2.5 ... 70	$I_{d,max} = \text{approx. } 22 \text{ kA}$	3RV10 41-4MA10
Short-circuit protection for infeed block with spring-type connection		
4	$I_{d,max} = 9.5 \text{ kA}$, $I^2t = 85 \text{ kA}^2\text{s}$	3RV10 21-4DA10
6	$I_{d,max} = 12.5 \text{ kA}$, $I^2t = 140 \text{ kA}^2\text{s}$	3RV10 31-4EA10
10	$I_{d,max} = 15 \text{ kA}$, $I^2t = 180 \text{ kA}^2\text{s}$	3RV10 31-4HA10
16 / 25	$I_{d,max} = 19 \text{ kA}$, $I^2t = 440 \text{ kA}^2\text{s}$	3RV10 41-4JA10
Short-circuit protection for terminal block		
1.5	$I_{d,max} = 7.5 \text{ kA}$	5SY...
2.5	$I_{d,max} = 9.5 \text{ kA}$	1)
4	$I_{d,max} = 9.5 \text{ kA}$	
6	$I_{d,max} = 12.5 \text{ kA}$	

1) To prevent the possibility of short-circuits, the cables on the terminal block must be installed so that they are short-circuit resistant according to EN 60439-1 Section 7.5.5.1.2.

For Operation in the Control Cabinet

3RA6 Compact Feeders

Infeed systems for 3RA6

Technical specifications

Type	3RA6.		
General data			
Max. rated operational current			
• Infeed with screw connection 50/70 mm ²	A	100	
• Infeed with screw connection 25/35 mm ²	A	63	
• Infeed with spring-type connection 25/35 mm ²	A	63	
• Expansion plug	A	63	
Permissible ambient temperature			
• During operation	°C	-20 ... +60 (over +40 current reduction is required)	
- Permissible rated current at control cabinet inside temperature: +40 °C	%	100	
+60 °C	%	80	
• During storage/transport	°C	-55 ... +80	
Relative air humidity			
	%	10 ... 90	
Installation altitude			
	m	Up to 2000 above sea level without restriction	
Rated operational voltage U_e			
	V	690 AC	
Rated frequency			
	Hz	50/60	
Shock resistance			
		$a = 60 \text{ m/s}^2 = 6g$ with 10 ms; for every 3 shocks in all axes	
Vibratory load			
		$f = 1 \dots 6 \text{ Hz}$; $d = 15 \text{ mm}$ 10 cycles $f = 150 \text{ Hz}$; $a = 2 g$	
Degree of protection		Acc. to IEC 60947-1	IP20 (IP 00 terminal compartment)
Touch protection		Acc. to EN 50274	Finger-safe
Degree of pollution			3
Short-circuit protection for infeed with screw connection (25/35 mm²) and infeed with screw connection (50/70 mm²)			
	$I_{d,max}$	kA	< 21
	I^2t	kA ² s	530
			Recommendation for upstream short-circuit protection device 3RV1041-4JA10 3RV1041-4MA10 LV HRC gL/gG 3NA3, 315 A
Short-circuit protection for infeed with spring-type connection			
• Conductor cross-section 4 mm ²	$I_{d,max}$	kA	< 9.5
	I^2t	kA ² s	85
• Conductor cross-section 6 mm ²	$I_{d,max}$	kA	< 12.5
	I^2t	kA ² s	140
• Conductor cross-section 10 mm ²	$I_{d,max}$	kA	< 15
	I^2t	kA ² s	180
• Conductor cross-section 16/25 mm ²	$I_{d,max}$	kA	< 19
	I^2t	kA ² s	440
			Recommendation for upstream short-circuit protection device 3RV1021-4DA10 3RV1031-4EA10 3RV1031-4HA10 3RV1041-4JA10
Short-circuit protection for terminal block			
• Conductor cross-section 1.5 mm ²	$I_{d,max}$	kA	7.5
• Conductor cross-section 2.5 mm ²	$I_{d,max}$	kA	9.5
• Conductor cross-section 4 mm ²	$I_{d,max}$	kA	9.5
• Conductor cross-section 6 mm ²	$I_{d,max}$	kA	12.5
			Recommendation for upstream short-circuit protection device 5SY... 1)











1) To prevent the possibility of short-circuits, the cables on the terminal block must be installed so that they are short-circuit resistant according to EN 60439-1 Section 7.5.5.1.2.

Type	3RV19.		
Connection type			
			 Spring-type connection
Conductor cross-sections of terminal block			
Order No.			
3RV19 17-5D			
Conductor cross-sections			
• Solid	mm ²	1.5 ... 6	
• Finely stranded with end sleeve	mm ²	1.5 ... 4	
• Finely stranded without end sleeve	mm ²	1.5 ... 6	
• AWG cables, solid or stranded	AWG	15 ... 10	

For Operation in the Control Cabinet

3RA6 Compact Feeders

Infeed systems for 3RA6

Type	3RA6.				
Connection type	 Screw connection				
Conductor cross-sections of infeed with screw connection 25/35 mm² (L1, L2, L3)¹⁾ and PE infeed 25/35 mm²					
Order No.	3RA68 12-8AB, 3RA68 12-8AC, 3RA68 60-6AB				
Tools	Pozidriv	Size 2			
Specified tightening torque	NM	3 ... 4.5			
					
Conductor cross-sections					
• Solid	mm ²	2.6 ... 16	2.6 ... 16		max. 2 x 16
• Stranded	mm ²	2.5 ... 35	2.5 ... 35		max. 2 x 25
• Finely stranded with end sleeve	mm ²	2.5 ... 25	2.5 ... 25		max. 2 x 16
• Finely stranded without end sleeve	mm ²	2.5 ... 25	2.5 ... 25		max. 2 x 16
• AWG cables	AWG	12 ... 2	12 ... 2		max. 2 x (18 ... 2)
Connection type	 Screw connection				
Conductor cross-sections of infeed with screw connection 50/70 mm² (L1, L2, L3)¹⁾					
Order No.	3RA68 13-8AB, 3RA68 13-8AC				
Tools	SW	4			
Specified tightening torque	NM	6 ... 8			
					
Conductor cross-sections					
• Solid	mm ²	2.5 ... 16	2.5 ... 16		max. 2 x 16
• Stranded	mm ²	4 ... 70	10 ... 70		max. 2 x 50
• Finely stranded with end sleeve	mm ²	2.5 ... 35	2.5 ... 50		max. 2 x 35
• Finely stranded without end sleeve	mm ²	4 ... 50	10 ... 50		max. 2 x 35
• AWG cables	AWG	10 ... 2/0	10 ... 2/0		max. 2 x (10 ... 1/0)
Connection type	 Spring-type connection				
Conductor cross-sections of infeed with spring-type connection 25/35 mm² (L1, L2, L3)¹⁾ and PE infeed 25/35 mm²					
Order No.	3RA68 30-5AC, 3RA68 60-5AC				
Tools	8WA2 806 mm	5.5 x 0.8			
Conductor cross-sections					
• Solid	mm ²	4 ... 16			
• Stranded	mm ²	4 ... 35			
• Finely stranded with end sleeve	mm ²	4 ... 25			
• Finely stranded without end sleeve	mm ²	6 ... 25			
• AWG cables	AWG	10 ... 3			
Connection type	 Screw connection		 Spring-type connection		
Conductor cross-sections of infeed with screw connection 25/35 mm² (T1, T2, T3)²⁾, infeed with screw connection 50/70 mm² (T1, T2, T3)²⁾, 2-socket and 3-socket expansion modules (T1,T2,T3)²⁾ and PE pick-off 6/10 mm²					
Order No.	3RA68 12-8AB, 3RA68 13-8AB, 3RA68 22-0AB, 3RA68 23-0AB, 3RA68 70-4AB		3RA68 12-8AC, 3RA68 13-8AC, 3RA68 22-0AC, 3RA68 23-0AC, 3RA68 70-3AC		
Tools		Pozidriv size 2		(3.5 x 0.5) mm, 8WA2 803	
Specified tightening torque	NM	2 ... 2.5		--	
Maximum rated current	A	12	32	12	32
Conductor cross-sections					
• Solid	mm ²	2 x (1 ... 2.5)	2 x (2.5 ... 6)	2 x (1.5 ... 6)	2 x (2.5 ... 6)
	mm ²	2 x (2.5 ... 6)			
	mm ²	max. 1 x 10	max. 1 x 10	max. 1 x 10	max. 1 x 10
• Finely stranded with end sleeve	mm ²	--	--	2 x (1.5 ... 6)	2 x (2.5 ... 6)
• Finely stranded without end sleeve	mm ²	2 x (1 ... 2.5)	2 x (2.5 ... 6)	2 x (1.5 ... 6)	2 x (2.5 ... 6)
	mm ²	2 x (2.5 ... 6)			
• AWG cables	AWG	2 x (16 ... 14)	2 x (14 ... 10)	2 x (16 ... 10)	2 x (14 ... 10)
	AWG	2 x (14 ... 10)			
	AWG	1 x 8	1 x 8	1 x 8	1 x 8

1) L1, L2, L3 main conductors on input side.

2) T1, T2, T3 main conductors on output side.

For Operation in the Control Cabinet

3RA6 Compact Feeders

Infeed systems for 3RA6

Dimensional drawings

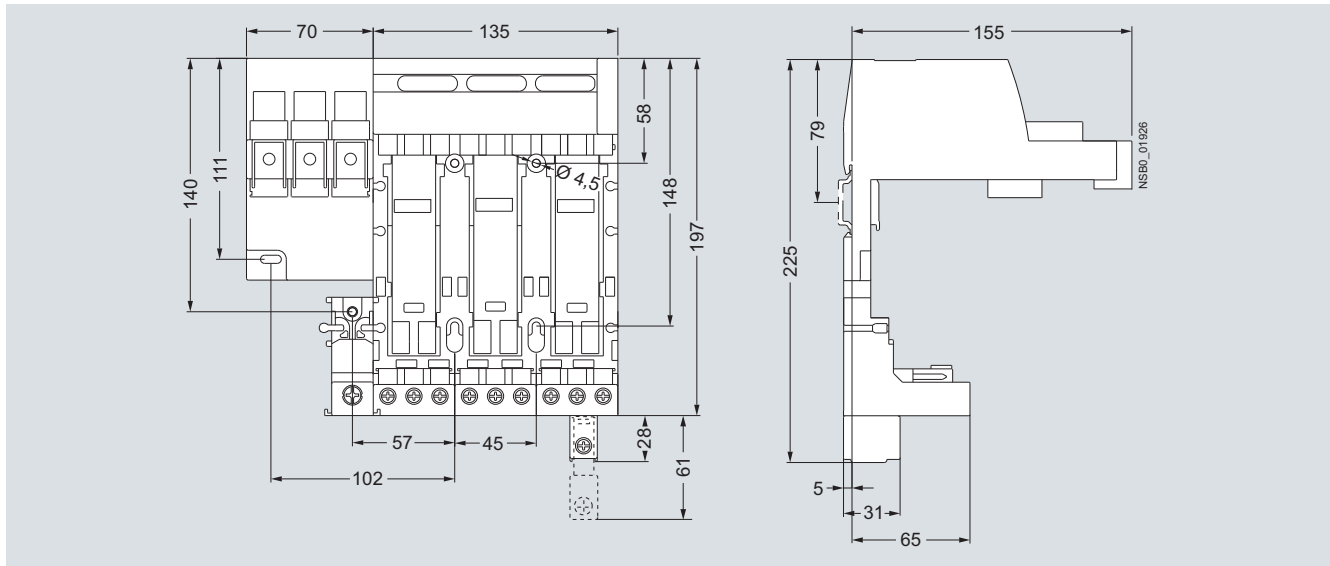

Infeed with screw connection 50/70 mm² on left with fixed 3-socket expansion module with outgoing screw terminals

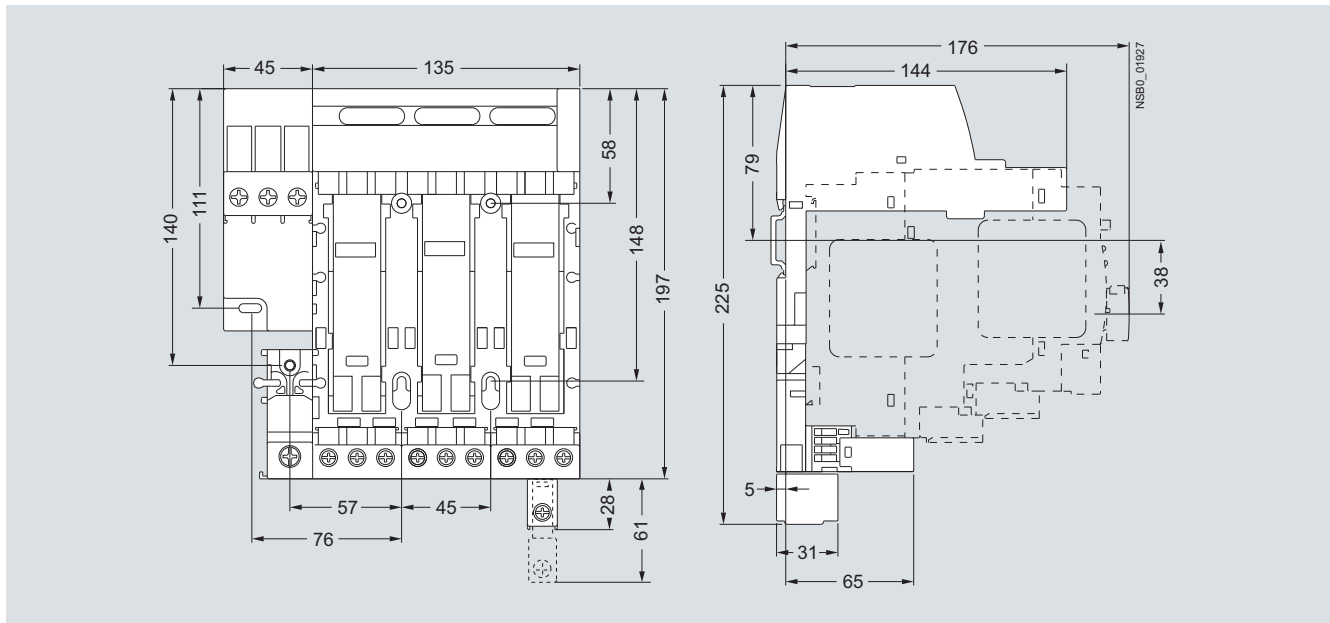

Infeed with screw connection 25/35 mm² on left with fixed 3-socket expansion module with outgoing screw terminals

For Operation in the Control Cabinet

3RA6 Compact Feeders

Infeed systems for 3RA6

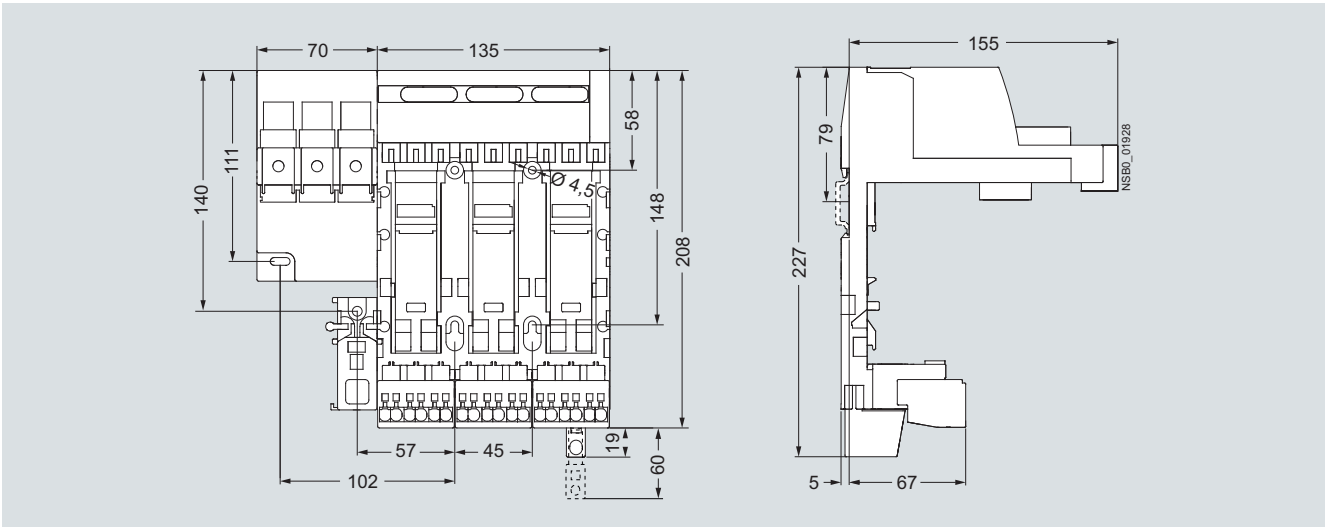

Infeed with screw connection 50/70 mm² on left with fixed 3-socket expansion module with outgoing spring-type terminals

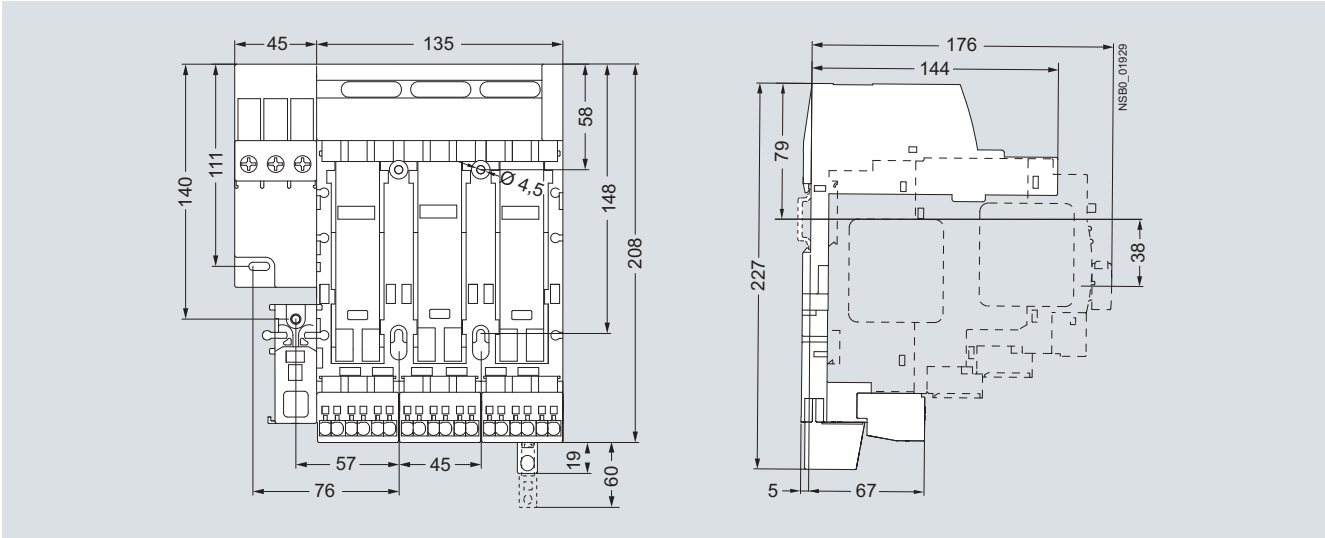

Infeed with screw connection 25/35 mm² on left with fixed 3-socket expansion module with outgoing spring-type terminals

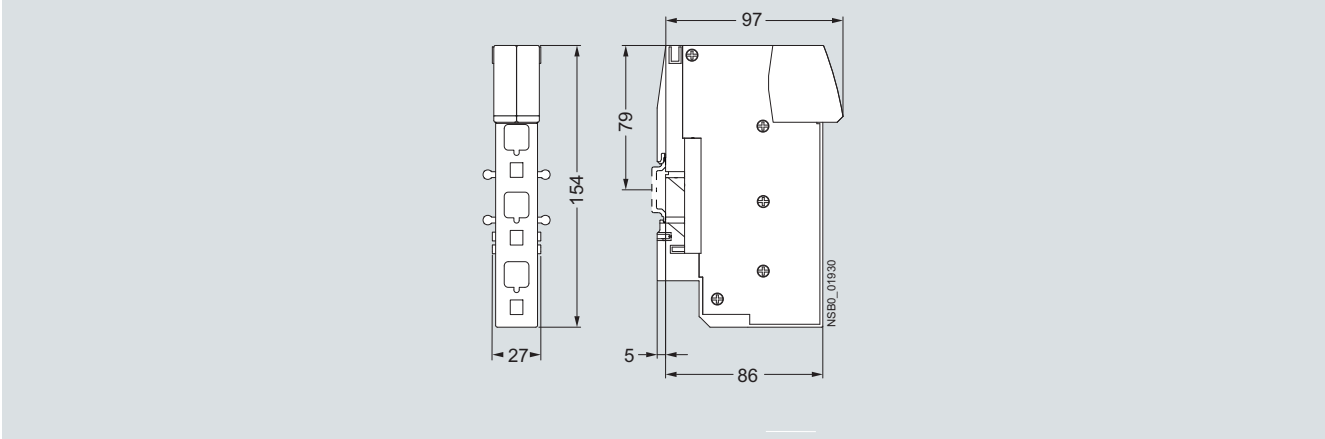

Infeed with spring-type terminals

6

For Operation in the Control Cabinet

3RA6 Compact Feeders

Infeed systems for 3RA6

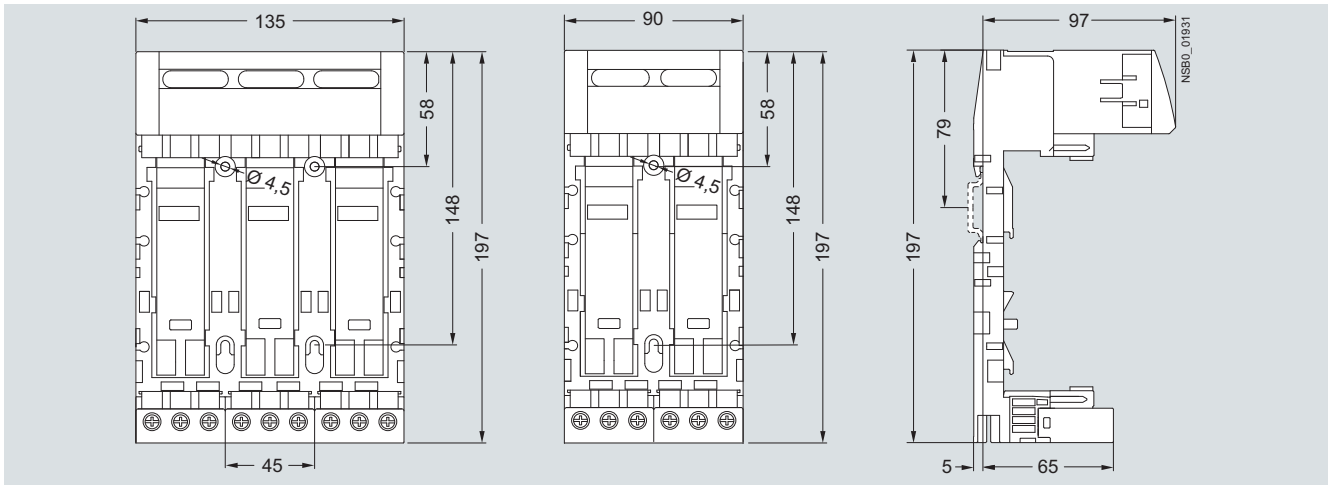

3-socket expansion module and 2-socket expansion module with outgoing screw terminals

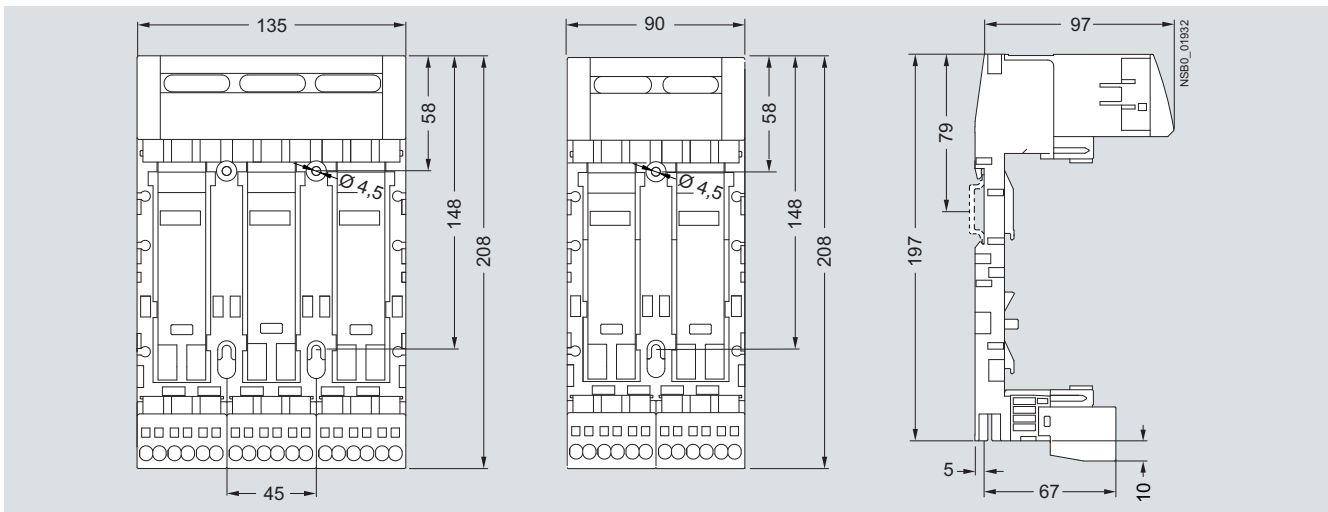

3-socket expansion module and 2-socket expansion module with outgoing spring-type terminals

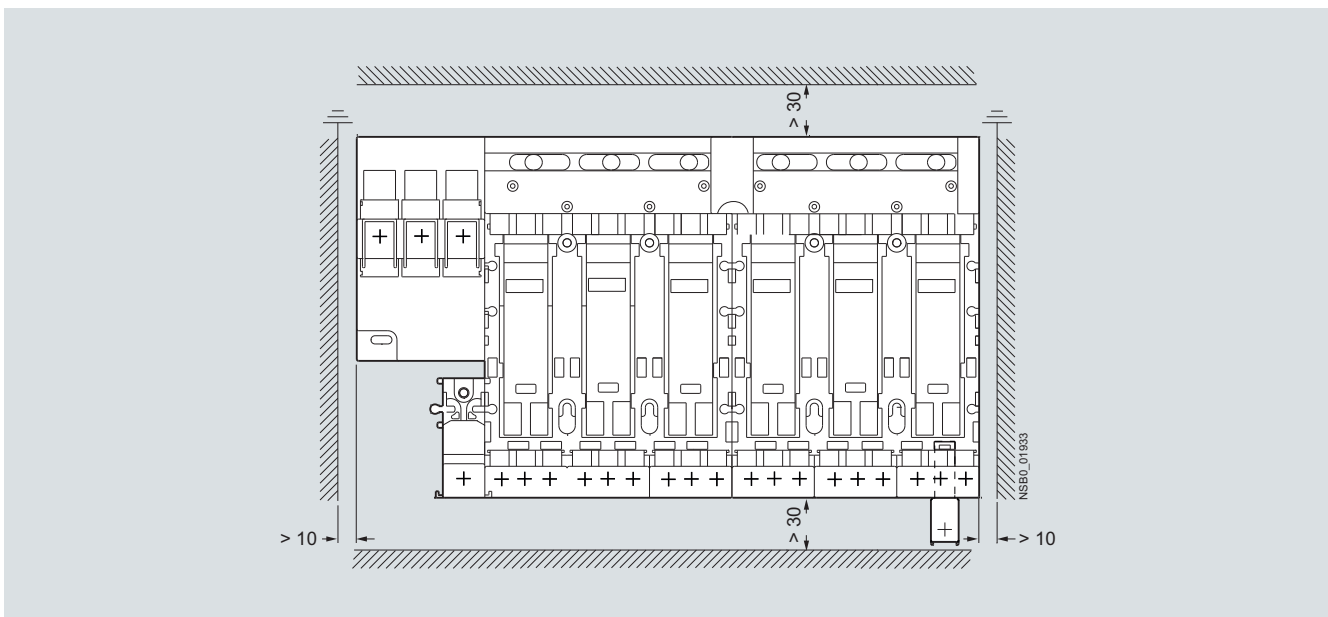

Minimum clearances to adjacent components when using infeed system for 3RA6

For Operation in the Control Cabinet

ET 200S Motor Starters

ET 200S motor starters

Overview

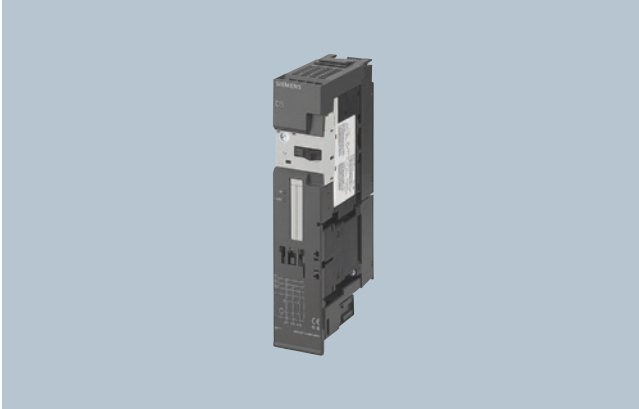

Motor starter, Standard, DS1-x direct-on-line starter



Motor starter, High-Feature, DS1e-x direct-on-line starter

- Completely factory-wired motor starters for switching and protecting any AC loads
- Can be used as a direct-on-line, reversing or soft starter
- Standard motor starter with motor starter protector and contactor assembly up to 5.5 kW
- High-feature motor starter with a combination comprising a starter protector, solid-state overload protection and contactor or soft starter up to 7.5 kW
- With self-assembling 40/50 A power bus, i. e. the load voltage is only supplied once for a group of motor starters
- Hot swapping is permissible
- Inputs and outputs for activating and signaling the statistics have been integrated
- Diagnostics capability for active monitoring of the switching and protection functions
- Can be combined with expansion modules: Brake control module for controlling electromechanical brakes in induction motors and with two optional inputs for special functions (for quick stop with the Standard motor starter and for parameterizable special functions with the High-Feature motor starter)
- For combining with safety technology (see [ET 200S Solutions Local/PROFIsafe Safety Motor Starters, page 6/121 onwards](#)) for use in safety-related system components (EN 954-1).

Motor Starter ES software

The Motor Starter ES software is used for the parameterization, monitoring, diagnostics and testing of motor starters. See [Catalog LV 1, Chapter 12 "Planning and Configuration with SIRIUS"](#).

For Operation in the Control Cabinet

ET 200S Motor Starters

ET 200S motor starters

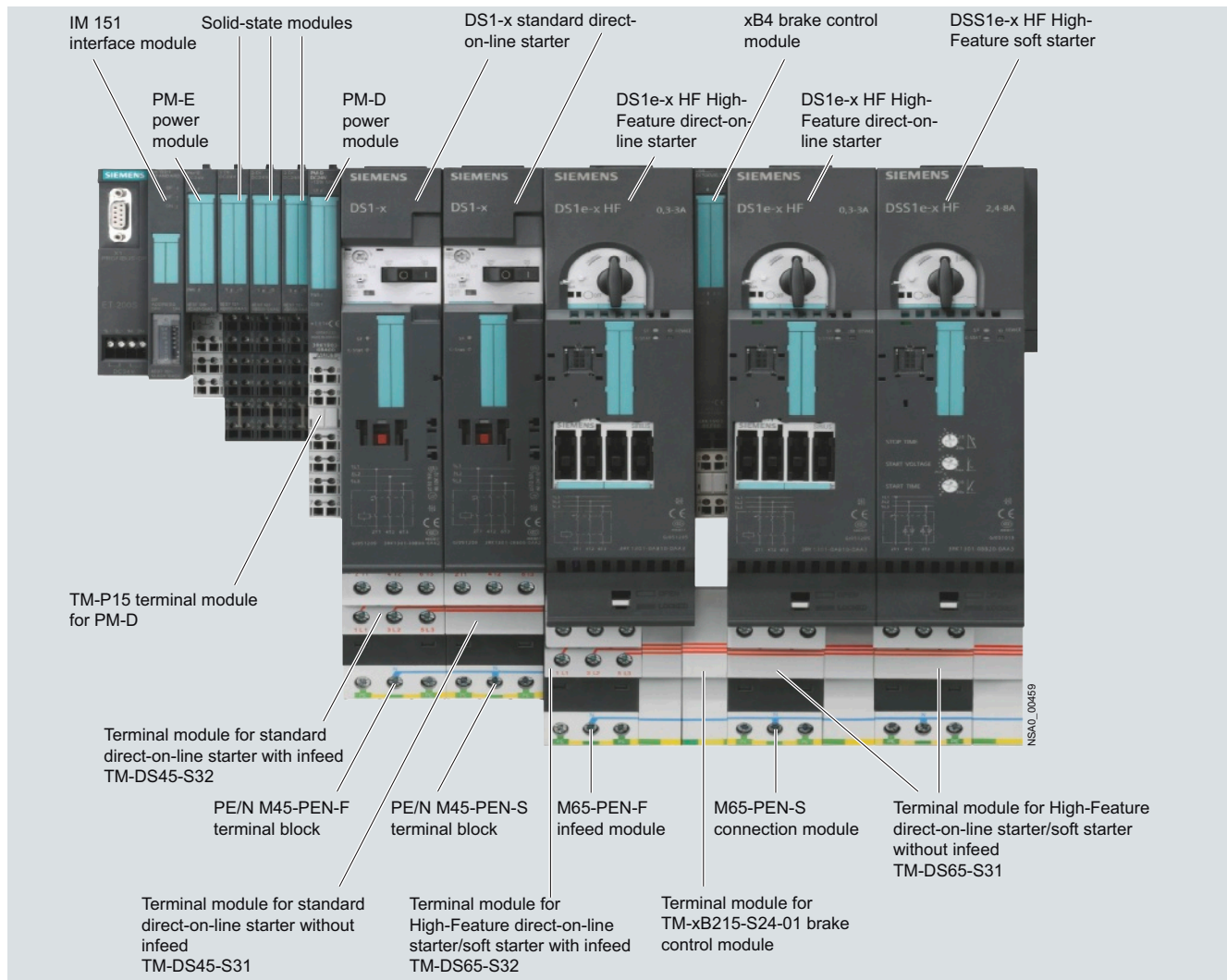

Interplay of ET 200S motor starter components

Design

Power is supplied through the terminal modules for motor starters. While the auxiliary voltages must be fed in once through the PM-D or PM-DFx power module, which is to be plugged in on the left side of the first motor starter, the load voltage must be fed in at the first TM-xxxxS32 terminal module (on the left) of a motor starter. The other TM-xxxxS31 terminal modules are automatically supplied as well through the integrated power bus when they are mounted side by side.

If the power bus is utilized to its full capacity of 40 A (Standard motor starters) or 50 A (High-Feature motor starters), a new supply is fed in through an additional TM-xxxxS32 terminal module. This also applies when transferring from a Standard motor starter to a High-Feature motor starter and vice versa. In this case, however, no PM-D power module must be placed in between.

Note:

Soft starters as well as frequency converters are both suitable for taking special care of mechanical systems. Soft starters are often used for loads with a square curve (pumps, compressors, fans).

Frequency converters are often used for varying loads and when constant starting times are required (conveying systems).

It should be noted that during starting with soft starters the torque is reduced by approx. 20 % (compared to operation with direct-on-line starters/frequency converters). The motor must be dimensioned accordingly. Soft starters can be used typically with switching frequencies of up to 20 operations/h.

For Operation in the Control Cabinet

ET 200S Motor Starters

ET 200S motor starters

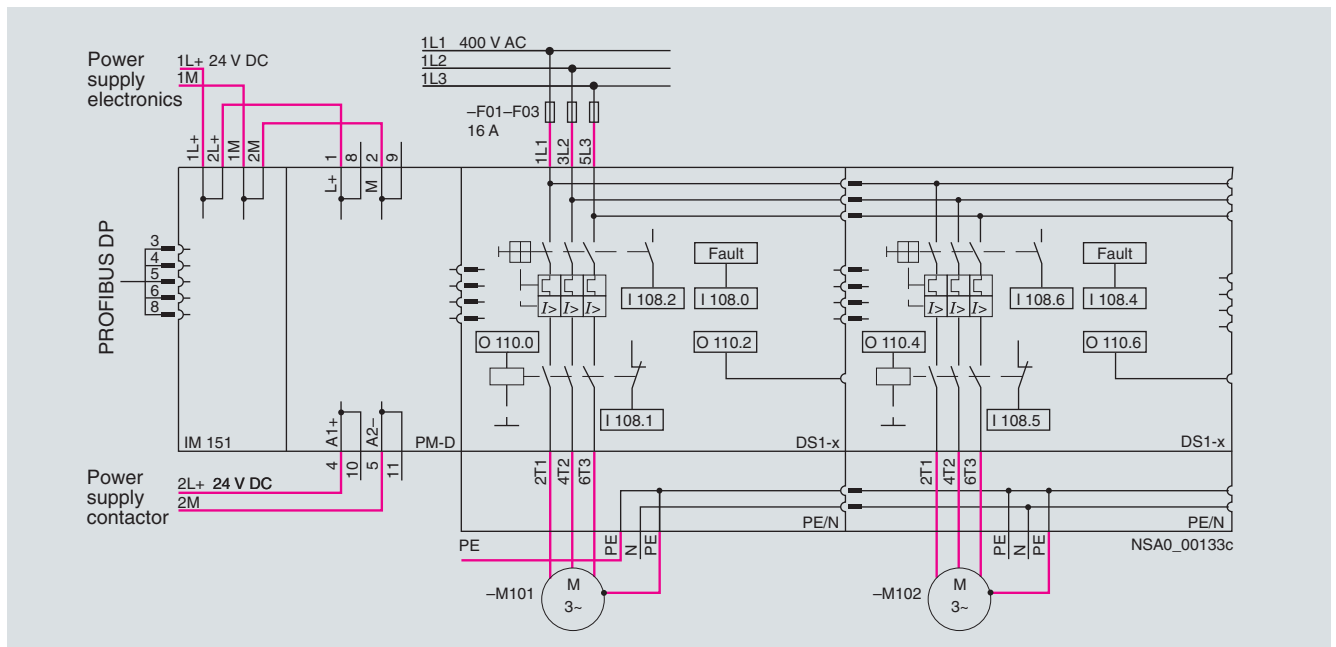

Sample illustration of an ET 200S station with PM-D power module and two standard motor starters

Accessories for motor starters, Standard

Control unit

With the control unit the contactor coils of the Standard motor starter can be directly controlled using 24 V DC. The motor starter can thus be started as normal using a local control point without PLC or bus.

Note:

The control unit cannot be used in combination with the safety technology or a brake control module.

Control kit

The control kit for the standard motor starter provides the possibility of testing the motor during start-up or service by actuating the motor starter protector. Using the control kit with the motor starter protector tripped, the contactor is mechanically locked in ON position.

Accessories for High-Feature motor starters

2DI 24 V DC COM control module

The 2DI 24 V DC COM control module is plugged onto the interface on the front of the motor starter. The module provides two inputs which can receive signals from the process and be assigned directly to the starter.

The functionality can be selected from a list of various control functions as part of the PROFIBUS parameterization. Local control point, emergency start and quick stop, for example, are available as functions. The signal levels can also be parameterized (NO/NC). For more extensive control functions the two inputs of a xB3 or x4 brake control module, which is plugged in alongside on the right, can be integrated in addition. The signal states of all inputs are transmitted in parallel with the internal use to the higher-level control system.

When a motor starter is replaced, the parameterization is automatically transmitted by download to the new starter. The inputs on the motor starter ensure autonomous operation, e. g. in the event of PLC failure, on the one hand and short response times through direct processing in the starter on the other hand. Another advantage results from the direct assignment of functions to modular machine concepts.

The 2DI 24 V DC COM control module has in addition a PC interface for connecting the Switch ES Motor Starter parameterization and diagnostics software (Version 2.0 and higher). The

module works solely on High-Feature motor starters with ES Motor Starter interface. The Logo!-PC cable is used as connecting cable between the 2DI 24 V DC COM control module and the High-Feature motor starter.

DM-V15

- Significant only in conjunction with a Standard motor starter
- Passive module without bus connection and terminals
- Does not need a separate terminal module
- Follows a TM-DS45 or TM-RS90 or TM-xB if required
- Does not need to be taken into account when configuring the GSD file

Function

All ET 200S motor starters are set up without fuses. Contactors and soft starters are activated through the integrated outputs. If a brake control module is arranged next to a motor starter, its solid-state brake switch is operated by an output of the motor starter. This module must always be arranged next to the motor starter on the right-hand side. The inputs of the motor starters evaluate the signal states of the protective devices (short-circuit or overload), the switching states of contactor(s) or soft starters, and system faults.

The motor starter protector signaling is freely programmable with regard to group fault signals (group fault at motor starter protector "Off"/group fault signal at motor starter protector "Off" only in case of "On" command from the motor starter).

For Operation in the Control Cabinet

ET 200S Motor Starters

ET 200S motor starters

Technical specifications

		Motor starters Standard DS1-x, RS1-x	Motor starters High-Feature DS1e-x, RS1e-x	Motor starters High-Feature DSS1e-x
Motor starters for connection to ET 200S, max.¹⁾		42	17	17
Mounting dimensions (W x H x D)				
• Direct-on-line starter	mm	45 x (265 + 45) x (120 + 27); (45: PE/N module; 27: Aux. switch contactor from F-Kit)	65 x (290 + 45) x (150 + 23); (45: PE/N module; 23: Control module)	
• Reversing starters	mm	90 x (265 + 45) x (120 + 27); (45: PE/N module; 27: Aux. switch contactor from F-Kit)	130 x (290 + 45) x (150 + 23); (45: PE/N module; 23: Control module)	
Permissible ambient temperature				
• During operation	°C	0 ... +60, from +40 with derating	0 ... +60 With horizontal mounting up to +40	
• During storage	°C	-40 ... +70	-40 ... +70	
• Permissible mounting position	°C	Vertical, horizontal With derating	Vertical, horizontal	
Vibration resistance acc. to IEC 60068, Part 2-6	g	2		
Shock resistance acc. to IEC 60068, Part 2-27	g/ms	Square 5/11		
Power consumption				
• From auxiliary circuit L+/M (U_1)	mA	Approx. 20	Approx. 40	Approx. 40
• From auxiliary circuit A1/A2 (U_2)	mA	Approx. 100	Approx. 1700 (80 ms long) Approx. 350 (after 80 ms)	Approx. 30
Rated operational current for TM-D terminal modules I_e	A	40	50	50
Rated operational voltage U_e	V	400		
Approval to EN 61140	V	Yes, up to 500	Yes, up to 500	Yes, up to 480
CSA approval and U_L	V	Yes, up to 600	Yes, up to 600	Yes, up to 480
Conductor cross-section				
• Solid	mm ²	2 x (1 ... 2.5) ² ; 2 x (2.5 ... 6) ² , acc. to IEC 60947: max. 1 x 10		
• Finely stranded with end sleeve	mm ²	2 x (1 ... 2.5) ² ; 2 x (2.5 ... 6) ²		
• AWG cables, solid or stranded	AWG	2 x (14 ... 10)		
Degree of protection		IP20		
Touch protection		Finger-safe (this also applies to terminal modules on a dismantled motor starter)		
Degree of pollution				
• At 400 V		3, IEC 60664 (IEC 61131)		
• At 500 V		2, IEC 60664 (IEC 61131)		
Rated impulse withstand voltage U_{imp}	kV	6		
Rated insulation voltage U_i	V	500		
Rated operational current I_e for motor starters				
• AC-1/2/3 at 60 °C				
- At 400 V	A	12	16	3 / 8 / 16
- At 500 V	A	9	11	--
• AC-4 at 60 °C				
- At 400 V	A	4.1	9	--
Rated short-circuit breaking capacity	kA	50 at 400 V		
Power of induction motors at 500 V	kW	5.5	7.5	
Utilization categories		AC-1, AC-2, AC-3, AC-4		
Protective separation between main and auxiliary circuits	V	400, acc. to EN 61140		
Positively-driven operation of contactor relay (NC)		Yes	Yes	--
Trip class		Class 10	Class 10/20, can be parameterized	0.3 ... 3 A: Class 10/10A, can be parameterized 2.4 ... 8 A: Class 10A 2.4 ... 16 A: Class 10A
Stall protection		No	Yes, 8 x I_e / 1 s	
Motor starter protector signaling		Yes	Parameterizable: always / only in case of "On" commands	
Overload warning		No, only tripping	Yes	
Emergency start function		No	Yes	
Type of coordination		Up to 1.6 A: 2 Up to 12 A: 1	Up to 16 A: 2	Up to 16 A: 1
Mechanical endurance				
• Motor starter protector	Oper-	100 000		
• Contactors	ating	30 million	10 million	--
• Contactor with safety functionality (F-Kit)	cycles	10 million	--	--

¹⁾ Additional limits: process image, max. design width 2 m.

²⁾ If two different conductor cross-sections are connected to one clamping point, both cross-sections must lie in the range specified. If identical cross-sections are used, this restriction does not apply.

For Operation in the Control Cabinet

ET 200S Motor Starters

ET 200S motor starters

		Motor starters Standard DS1-x, RS1-x	Motor starters High-Feature DS1e-x, RS1e-x	Motor starters High-Feature DSS1e-x
Electrical endurance				
• Motor starter protector	h	100 000		
• Contactors		See manual	See manual	--
Permissible switching frequency with a starting time $t_A = 0.1 \text{ s}$ and a relative ON period $t_{OP} = 50 \%$				
	1/h	< 80	See manual	
Induction protection				
		Already installed		
Operating times (Total break time = Opening delay + Arcing time)				
• Operating times at $0.85 \dots 1.1 \times U_e$				
- Closing time	ms	25 ... 100	25 ... 100	--
- Opening time	ms	7 ... 10	20 ... 50	--
• Operating times at $1.0 \times U_e$				
- Closing time	ms	30 ... 50	Typ. 25	--
- Opening time	ms	7 ... 9	Typ. 20	--
Arcing time				
	ms	10 ... 15	10 ... 15	--
Number of outputs				
		4	16	16
Number of inputs				
		4	16	16
Address area required per module				
• With summary	bit	4	--	--
• Without summary	byte	1	2	2
Diagnostics functions				
• Group fault "SF"		Red LED		
• Switching state "C-STAT"		Red/green/yellow LED		
• Device state "DEVICE"		--	Red/green/yellow LED	
Configurable through PROFIBUS DP				
		Yes		
Auxiliary switch for enabling circuit of the ET 200S safety technology already integrated (up to max. category 4 EN 954-1)				
		No, F-Kit required	Yes	No (max. Category 1 attainable)
Setting options for soft starters (locally on the device)				
• Starting time	s	--	--	0 ... 20
• Starting voltage	%	--	--	30 ... 100 of U_e
• Ramp-down time	s	--	--	0 ... 20
Input/output bit				
• DO 0		Motor on (clockwise)		
• DO 1		Motor on (counterclockwise)		
• DO 2		Control of brake (1 = tripped, motor without being braked)		
• DO 3		Reserved	Remote reset (e. g. in case of overload)	
• DO 4		Reserved	Emergency start	
• DO 5-8		Reserved		
• DI 0		Ready		
• DI 1		Motor on (feedback from contactor)	Motor on (feedback current is flowing)	
• DI 2		Motor starter protector tripped	Actuator shutdown (short-circuit, overload)/Device fault	
• DI 3		Reserved	Overload group warning	
• DI 4		Reserved	Input 1 (from brake control module)	
• DI 5		Reserved	Input 2 (from brake control module)	
• DI 6		Reserved	Input 3 (from brake control module 2DI)	
• DI 7		Reserved	Input 4 (from brake control module 2DI)	
• DI 8 ... DI 13		n/a	Motor current I_{actual}	
• DI 14		n/a	Reserved	
• DI 15		n/a	--	Ramp mode
Fault type (PROFIBUS diagnostics)				
• 00001: Short-circuit		--	Starter motor starter protector has tripped	
• 00100: Overload		--	Thermal motor model overload	
• 00111: Upper limit overshoot		--	I_e limit value overshoot	
• 01000: Lower limit value undershoot		--	I_e limit value undershoot	
• 01001: Fault		Internal fault/Device fault/Fault during self-test		
• 10000: Parameterizing fault		--	Wrong parameter value	
• 11000: Actuator shutdown		All designated faults/Unbalance/motor blocking (possibly with an additional fault entry describing the fault in more detail)		
• 11010: External fault		--	Input disconnection/Input disconnection limit/Process image fault	

For Operation in the Control Cabinet

ET 200S Motor Starters

ET 200S motor starters

Accessories

		Brake control module XB1	Brake control module XB3	Brake control module XB2	Brake control module XB4
Dimensions (W x H x D)	mm	15 x 196.5 x 125.5 including terminal module on 7.5 mm standard mounting rail			
Number of assigned outputs for the (left-hand) motor starter		1			
Rated operational voltage	V	24 DC		500 DC (min. 100)	
Power supply		Externally through terminal module		From brake rectifier through terminal module	
Rated operational current	A	4		0.7	
Reverse polarity protection		No, in the event of polarity reversal the brake is released and the overload/short-circuit protection is not effective			
Overload/short-circuit protection		Yes, solid-state			
Conductor cross-section of the terminal module for the brake control module	mm ²	1 x 2.5 without end sleeve 1 x 1.5 with end sleeve			
Number of outputs		0	1 (used internally)	0	1 (used internally)
Number of inputs		0	2	0	2
Address area required per module					
• With summary		0	2 bits	0	2 bits
• Without summary		0	1 byte	0	1 byte
Diagnostics functions					
• Group fault "SF"		Red LED			
• Switching state for brake "STAT"		Yellow LED			
• Inputs 1 and 5		--	Green LED	--	Green LED
Parameters (default values underlined>					
• Brake overload diagnostics		--	Disable/Enable	--	Disable/Enable
• Input delay	ms	--	0/0.1/0.5/3/15	--	0/0.1/0.5/3/15
Module width	mm	15			

Dimensional drawings

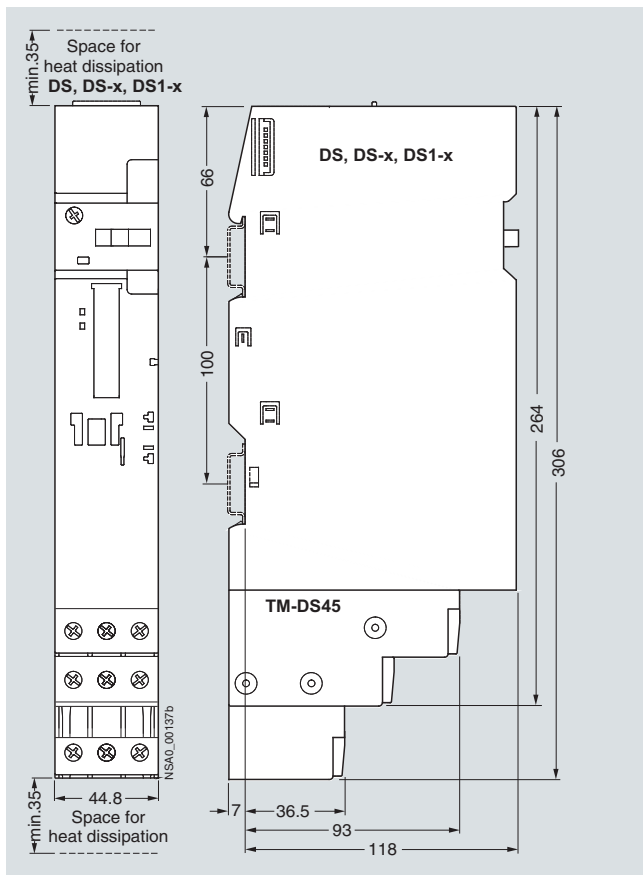

DS1-x direct-on-line starter with TM-DS 45 terminal module

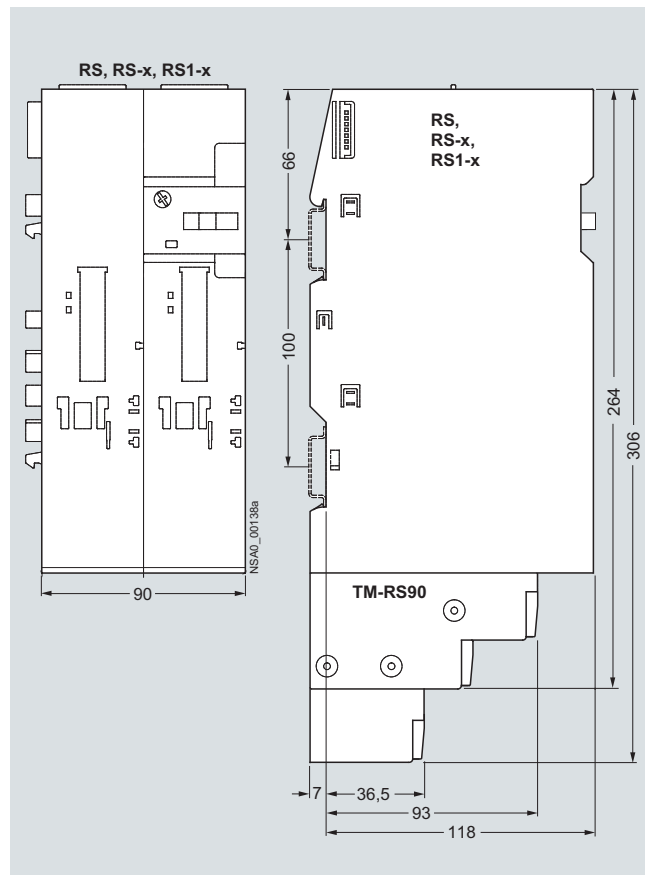

RS1-x reversing starter with TM-RS 90 terminal module

For Operation in the Control Cabinet

ET 200S Motor Starters

ET 200S motor starters

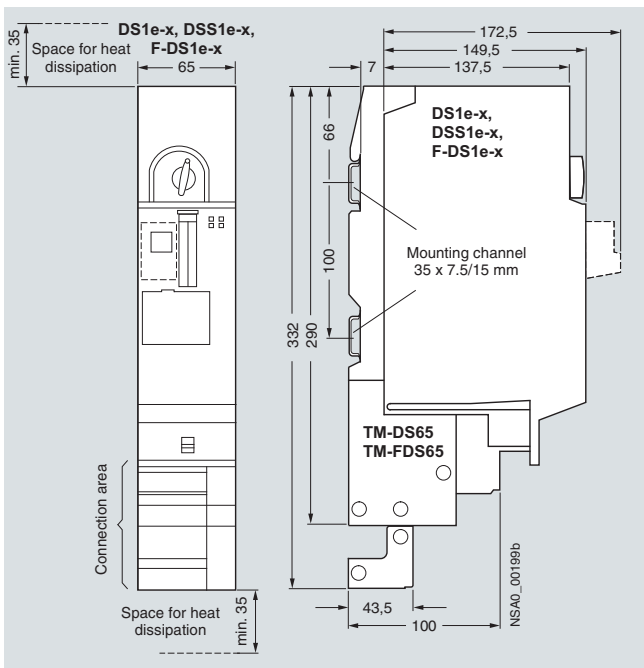

DS1e-x direct-on-line starter, DSS1e-x soft starter and F-DS1e-x terminal module

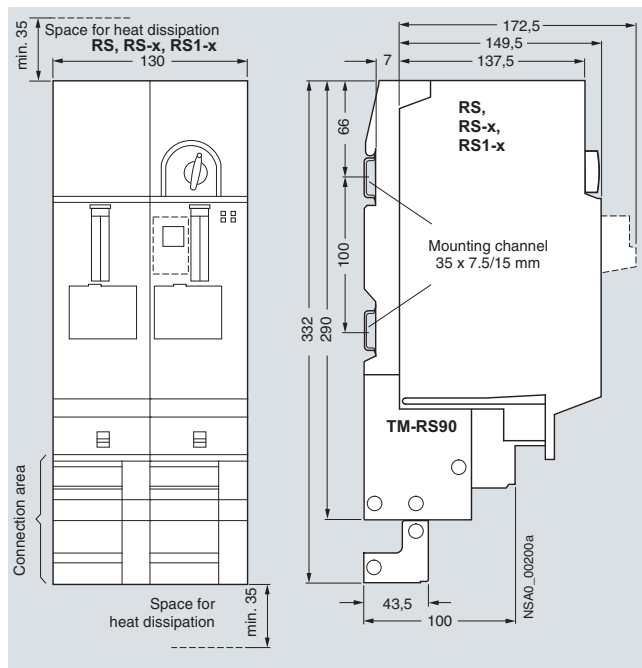

RS1e-x reversing starters and TM-RS130 terminal module

Accessories

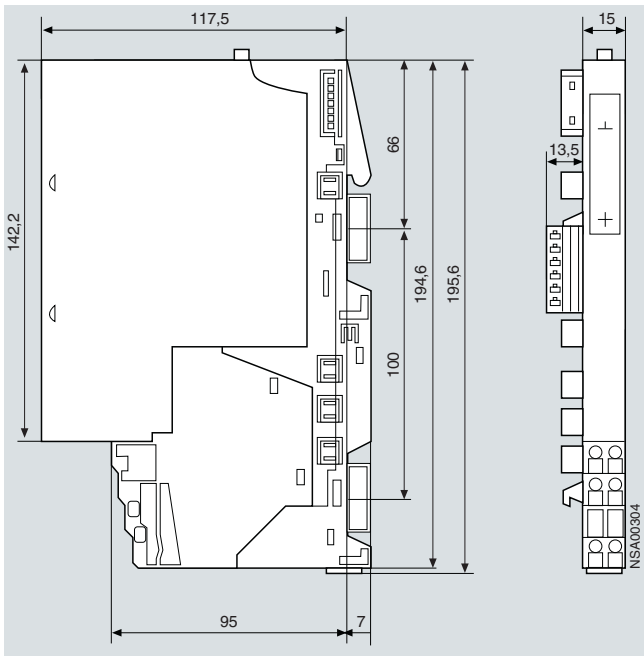

xB1 ... 4 brake control module with TM-xB215 terminal module

6

For Operation in the Control Cabinet

ET 200S Motor Starters

Power modules for ET 200S motor starters

Overview



- For supplying and monitoring the auxiliary voltages for motor starters
- Disconnection of a complete group of motor starters is possible without any additional outlay (safety category 1 according to EN 954-1)
- For plugging onto TM-P15 terminal module
- For supplying and monitoring the power supply for the ET 200S FC frequency converter

Design

PM-D power modules are plugged onto the TM-P15 terminal modules.

A PM-D power module must be followed by at least one motor starter or one frequency converter.

Technical specifications

		PM-D power module 3RK1 903-0BA00
Rated control supply voltage U_s Up to 60 °C	V	20.4 ... 28
Rated operational current I_e		
• Recommended short-circuit protection	A	10
• Melting fuse	A	10
• Miniature circuit breaker	A	10, Tripping characteristic B
Power consumption from the backplane bus	mA	≤ 10
Supplying		
• Motor starters		Yes
• Frequency converters		Yes
• Motor starters for safety technology		No
• Solid-state modules		No
• Ex(i) modules		No
Alarms		None
Diagnostics functions		Yes
• System fault/device fault		Red "SF" LED
• Monitoring the supply voltage for solid-state modules U_1		Green "PWR" LED
• Monitoring the supply voltage for contactors U_2		Green "CON" LED
• Diagnostics information can be read out		Yes
Conductor cross-sections		
• Flexible with end sleeve	mm ²	1.5
• Rigid	mm ²	2.5
Mounting dimensions (W x H x D)	mm	15 x 195.5 x 117.5

Dimensional drawings

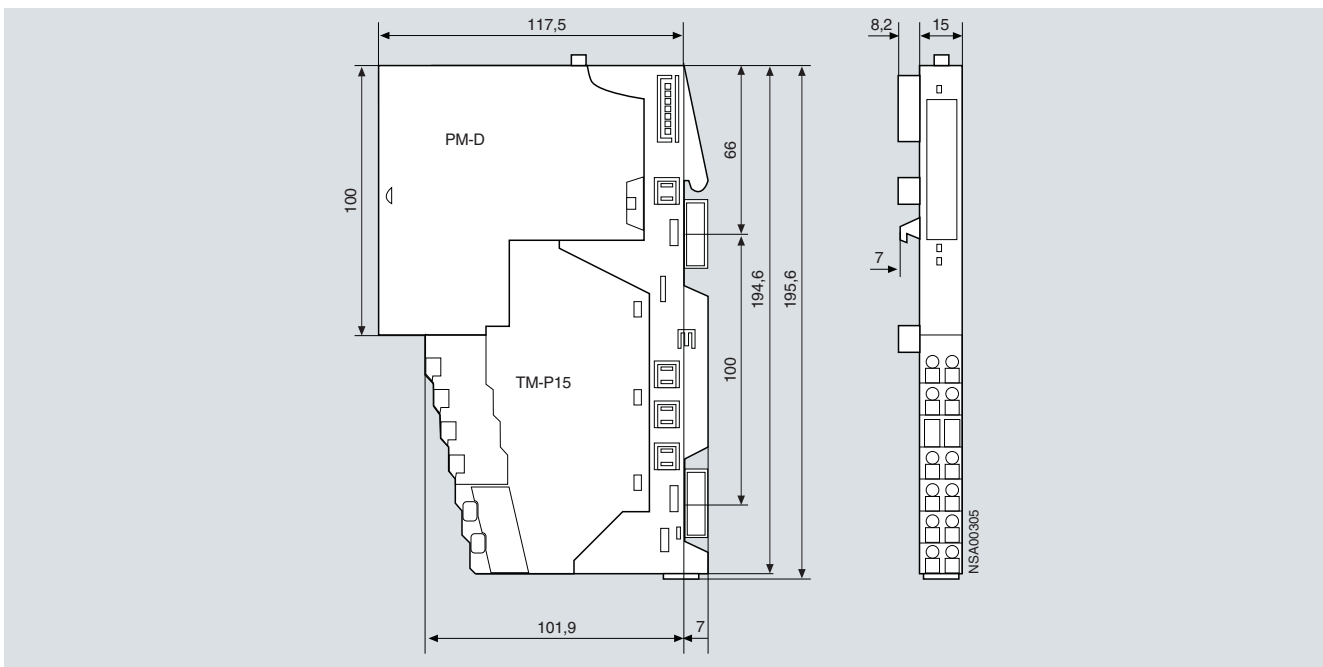

PM-D power module and TM-P15 terminal module

For Operation in the Control Cabinet

ET 200S Motor Starters

Terminal modules for ET 200S motor starters

Overview

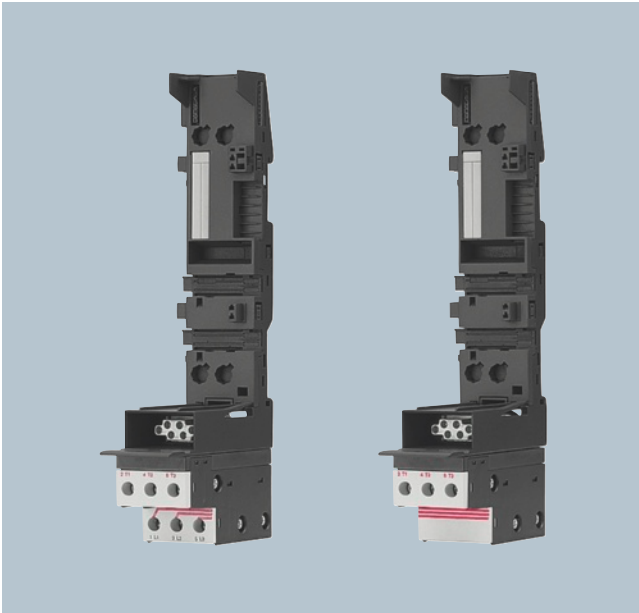

Terminal modules for motor starters

- Mechanical modules in which the motor starter and expansion modules are inserted
- For constructing the permanent wiring and self-assembling voltage bus
- For connecting the motor connection cables
- Positive-locking connection to ensure enhanced vibration resistance

Terminal modules for frequency converters

- Mechanical modules in which the components of the frequency converter are inserted
- For constructing the permanent wiring and self-assembling voltage bus
- For connecting the motor cables
- Integrated shield attachments for receiving the busbar 3 x 10 mm

Terminal module for power module

- Connection by means of screw terminals
- Light colored enclosure for visual distinction
- Always before the first TM-DS/TM-RS

Design

TM-DS, TM-RS

- "-S32" version with supply terminals: 2 x 3 x 10 mm² screw terminals for power bus and motor feeder
- "-S31" version without supply terminals: 1 x 3 x 10 mm² screw terminals for motor feeder
- Optionally expandable with PE/N modules (see Accessories)
- Applies only to Standard motor starters: For applications with high motor currents (> 6.3 A) or high ambient temperatures (> 40 °C) it is recommended to use the DM-V15 distance module (See Accessories) between two DS1-x motor starters

TM-ICU

- For ICU24/ICU24F control modules of the frequency converter

TM-IPM

- "TM-IPM65" version for IPM25 power section of the frequency converter with 0.75 kW
- "TM-IPM130" version for IPM25 power section of the frequency converter with 2.2 or 4.0 kW
- "-S32" version with supply terminals: 2 x 3 x 10 mm² screw terminals for power bus and motor feeder
- "-S31" version without supply terminals: 1 x 3 x 10 mm² screw terminals for motor feeder
- All TM-IPM units have an integrated shield attachment
- Optionally expandable with PE/N modules (see Accessories)

TM-xB

- Can be combined with Standard motor starters as well as High-Feature motor starters and frequency converters
- Connection by means of screw terminals
- Always next to the TM-DS/TM-RS on the right-hand side

Terminal module for power module

For supplying load and sensor voltage to the self-assembling potential bars of the Standard motor starters, High-Feature motor starters and frequency converters. Power modules for voltage monitoring are plugged onto TM-P modules. TM-P modules can be used any number of times within the ET 200S. A power module must always be plugged upstream from the first motor starter/frequency converter.

For Operation in the Control Cabinet

ET 200S Motor Starters

Terminal modules for ET 200S motor starters

Technical specifications

TM-P15 S27-01 terminal module

Dimensions		
• Mounting dimensions (W x H x D)	mm	15 x 196.5 x 102
• Depth with power module	mm	117.5
Rated voltages and rated currents		
• Rated insulation voltage	V	500
• Rated operational voltage	V	24 DC
• Rated operational current	A	10
Conductor cross-sections		
• Solid	mm ²	1 x (0.14 ... 2.5), acc. to IEC 60947 1 x 2.5
• Finely stranded with end sleeve	mm ²	1 x (0.14 ... 1.5), acc. to IEC 60947
• AWG cables, solid or stranded	AWG	1 x (18 ... 22)
Wiring		
• Required tool		Standard screwdriver size 1
• Tightening torque	NM	0.4 ... 0.7

TM-DS45 and TM-DS65/TM-FDS65 terminal module

		TM-DS45	TM-DS65/TM-FDS65
Dimensions			
• Mounting dimensions (W x H x D)	mm	45 x 264 x 100	65 x 290 x 100
• Height with PE/N terminal block	mm	306	332
• Depth with motor starter	mm	127	150
• Depth with motor starter and F-Kit (safety technology)	mm	152	--
• Depth with motor starter and 2DI control module	mm	--	173
Rated voltages, currents and frequencies for the power bus			
• Rated insulation voltage U_i	V	690	
• Rated operational voltage U_e	V	500 AC	
• Rated impulse withstand voltage U_{imp}	kV	6	
• Rated operational current I_e	A	40	50
• Rated frequency	Hz	50/60	
Conductor cross-sections			
• Solid	mm ²	2 x (1 ... 2.5) ¹⁾ or 2 x (2.5 ... 6) ¹⁾	
• Finely stranded with end sleeve	mm ²	1 x 10 or 2 x (1 ... 2.5) ¹⁾ or 2 x (2.5 ... 6) ¹⁾ acc. to IEC 60947	
• AWG cables, solid or stranded	AWG	2 x (14 ... 10)	
• With additional 3-phase feeder terminal if required			
- Solid or stranded	mm ²	1 x 2.5 ... 25	
- Finely stranded with end sleeve	mm ²	1 x 2.5 ... 25	
- AWG cables, solid or stranded	AWG	1 x 12 ... 4	
Wiring			
• Required tool		Standard screwdriver size 2 and Pozidriv 2	
• Tightening torque	NM	2.0 ... 2.5	

¹⁾ If two different conductor cross-sections are connected to one clamping point, both cross-sections must lie in the range specified. If identical cross-sections are used, this restriction does not apply.

For Operation in the Control Cabinet

ET 200S Motor Starters

Terminal modules for ET 200S motor starters

TM-RS90 and TM-RS130/TM-FRS130 terminal module

		TM-RS90	TM-RS130/TM-FRS130
Dimensions			
• Mounting dimensions (W x H x D)	mm	90 x 264 x 100	130 x 290 x 100
• Height with PE/N	mm	306	332
• Depth with motor starter	mm	127	150
• Depth with motor starter and F-Kit (safety technology)	mm	152	--
• Depth with motor starter and 2DI control module	mm	--	173
Rated voltages, currents and frequencies for the power bus			
• Rated insulation voltage U_i	V	690	
• Rated operational voltage U_e	V	500 AC	
• Rated impulse withstand voltage U_{imp}	kV	6	
• Rated operational current I_e	A	40	50
• Rated frequency	Hz	50/60	
Conductor cross-sections			
• Solid	mm ²	2 x (1 ... 2.5) ¹⁾ or 2 x (2.5 ... 6) ¹⁾	
• Finely stranded with end sleeve	mm ²	1 x 10 or 2 x (1 ... 2.5) ¹⁾ or 2 x (2.5 ... 6) ¹⁾ Acc. to IEC 60947	
• AWG cables, solid or stranded	AWG	2 x (14 ... 10)	
• With additional 3-phase feeder terminal if required			
- Solid or stranded	mm ²	1 x 2.5 ... 25	
- Finely stranded with end sleeve	mm ²	1 x 2.5 ... 25	
- AWG cables, solid or stranded	AWG	1 x 12 ... 4	
Wiring			
• Required tool		Standard screwdriver size 2 and Pozidriv 2	
• Tightening torque	NM	2.0 ... 2.5	

1) If two different conductor cross-sections are connected to one clamping point, both cross-sections must lie in the range specified. If identical cross-sections are used, this restriction does not apply.

TM-ICU15 terminal module

Dimensions		
• Mounting dimensions (W x H x D)	mm	15 x 195 x 52 (depth with control module 154)
Rated voltages and currents		
• Rated insulation voltage U_i	V	500 AC
• Rated operational voltage U_e	V	24 DC
• Rated operational current I_e	A	10

TM-IPM65 and TM-IPM130 terminal module

		TM-IPM65 terminal module	TM-IPM130 terminal module
Dimensions			
• Mounting dimensions (W x H x D)	mm	65 x 290 x 100	130 x 290 x 100
• Height with PE/N terminal block	mm	332	
• Depth with frequency converter power section	mm	150	
Rated voltages, currents and frequencies for the power bus			
• Rated insulation voltage U_i	V	690	
• Rated operational voltage U_e	V	500 AC	
• Rated impulse withstand voltage U_{imp}	kV	6	
• Rated operational current I_e	A	50	
• Rated frequency	Hz	50/60	
Conductor cross-sections			
• Solid	mm ²	2 x (1 ... 2.5) or 2 x (2.5 ... 6)	
• Finely stranded with end sleeve	mm ²	1 x 10 or 2 x (1 ... 2.5) ¹⁾ or 2 x (2.5 ... 6) ¹⁾ Acc. to IEC 60947	
• AWG cables, solid or stranded	AWG	2 x (14 ... 10)	
• With additional 3-phase feeder terminal if required			
- Solid or stranded	mm ²	1 x 2.5 ... 25	
- Finely stranded with end sleeve	mm ²	1 x 2.5 ... 25	
- AWG cables, solid or stranded	AWG	1 x 12 ... 4	
Wiring			
• Required tool		Standard screwdriver size 2 and Pozidriv 2	
• Tightening torque	NM	2.0 ... 2.5	

1) If two different conductor cross-sections are connected to one clamping point, both cross-sections must lie in the range specified. If identical cross-sections are used, this restriction does not apply.

For Operation in the Control Cabinet

ET 200S Safety Motor Starters Solutions local/PROFIsafe

General data

Overview

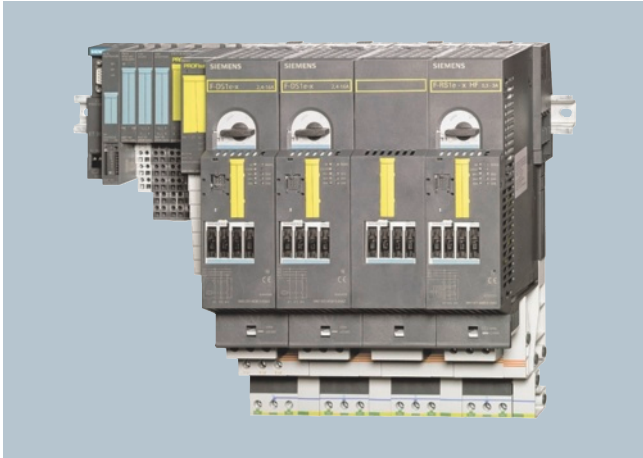

The ET 200S Safety motor starters Solutions comprise:

- Safety modules
- Standard motor starters
- High-Feature motor starters
- Failsafe motor starters

With the ET 200S Safety motor starters Solutions there is no complicated and hence cost-intensive configuring and wiring outlay compared to the conventional safety technology. The ET 200S Safety motor starter Solutions are designed for Category 4 according to EN 954-1 or SIL 3 to IEC 61508.

They enable the use of safety-oriented direct-on-line starters or reversing starters in the SIMATIC ET 200S distributed peripherals system on PROFINET or PROFIBUS. The fine modular architecture of the system permits optimum imaging of machine or plant applications.

Within an ET 200S station the Safety motor starters Solutions can also be combined with Standard motor starters or High-Feature motor starters without safety functions or the SIMATIC ET 200S FC frequency converter up to max. 4 kW up to Category 3 according to EN 954-1 or SIL 2 according to IEC 61508.

Standard and High-Feature ET 200S motor starters can be found on page 6/110 onwards.

The "SIMATIC ET 200 Configurator" software can be found in Catalog CA 01 on CD or DVD. You can also download the "SIMATIC ET 200 Configurator" software from the Internet:

<http://www.siemens.com/sirius-starting>

<http://www.siemens.com/ET200S>

Motor Starter ES software

The Motor Starter ES software is used for parameterization, monitoring, diagnostics and testing of motor starters.

See Catalog LV 1, Chapter 12 "Planning and Configuration with SIRIUS".

For Operation in the Control Cabinet

ET 200S Safety Motor Starters Solutions local/PROFIsafe

ET 200S Failsafe motor starters

Overview

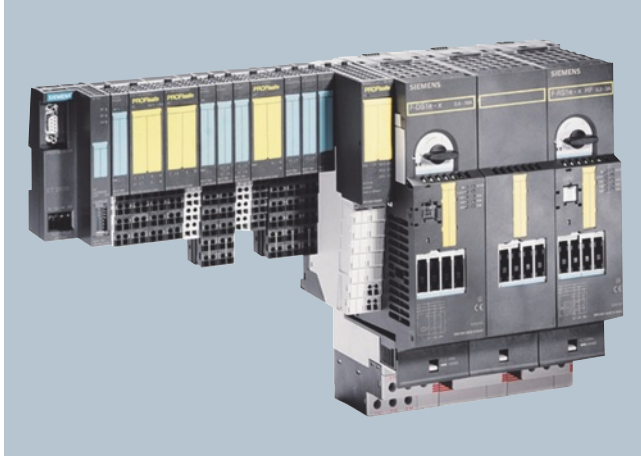

The Failsafe motor starter has been developed on the basis of the High-Feature motor starter. It differs in that, in addition to a motor starter protector and contactor assembly, a safe solid-state evaluation circuit is installed for error detection purposes which makes the motor starter failsafe.

If the contactor to be switched fails in an EMERGENCY-STOP case, the evaluation electronics detects a fault and opens the motor starter protector in the motor starter through a shunt trip unit in a failsafe manner. The second redundant shutdown component is therefore no longer a main contactor, as is generally the case, but the motor starter protector installed in the motor.

All functions of the High-Feature starter are already integrated

The new failsafe motor starters are characterized by easy, space-saving assembly as well as minimal wiring outlay. Like the High-Feature starters, the Failsafe motor starters have a switching capacity of up to 7.5 kW (16 A) which is achieved with just two motor starter versions. Another important feature is the high availability due to the high short-circuit strength (type of coordination "2").

Design

High degree of flexibility with safety technology

Solution PROFIsafe

In EMERGENCY-STOP applications, the Failsafe motor starters are selectively switched off through the upstream PM-D F PROFIsafe safety module. For each safety module, six switch-off groups can be formed. In the first delivery stage, the failsafe freely-programmable logic of the SIMATIC controller is used to interface with the relevant Failsafe sensor technology. The interface between PROFIsafe and installations that use conventional safety technologies is implemented through the F-CM Failsafe contact multiplier with four floating contacts.

Solution local

Failsafe motor starter with safety relay (Version 1) or ASIsafe (Version 2, see example 2, page 6/125):

Signals with relevance for safety can be input to ET 200S through a PM-D F X1 infeed terminal module through the enabling circuits of the AS-i Safety Monitor or the safety relay to control the Failsafe motor starters which then selectively switch off the downstream motors.

Technical specifications

*F-DS1e-x direct-on-line starters/
F-RS1e-x reversing starters*

		Direct-on-line starters	Reversing starters
Dimensions			
Dimensions (W x H x D)	mm	65 x 290 x 150 (incl. terminal module)	130 x 290 x 150 (incl. terminal module)
Height with PE/N module	mm	332	
Depth with 2DI control module (not safe)	mm	173	
Module-specific specifications			
Type of coordination		Type 2 up to $I_e \leq 16$ A at 400 V	
Internal power supply		U1 (from PM-D F/PM-DF X1)	
Maximum achievable safety class		SIL 3 Category 4	
• Acc. to IEC 61508			
• Acc. to EN 954-1			
Safety characteristics			
Low demand	PFD _{AVG} (10a)	3.5 x 10 ⁻⁵ 8.0 x 10 ⁻⁵	
• Test interval 3 months			
• Test interval 6 months			
High demand/continuous mode	PFH	8.1 x 10 ⁻¹⁰ 1.8 x 10 ⁻⁹	
• Test interval 3 months	1/h		
• Test interval 6 months	1/h		
Proof-test interval	Years	10	
Voltages, currents, potentials			
Switching capacity	A	Up to 7.5 kW at 400 V AC in three setting ranges: 0.3 ... 3 2.4 ... 8 2.4 ... 16	
Status, alarms, diagnostics			
Status display		SF, DEVICE and C-STAT, SG1 ... SG6	
Diagnostics functions			
Group fault display		Red LED (SF)	
Diagnostics information can be read out		Available	

For Operation in the Control Cabinet

ET 200S Safety Motor Starters Solutions local/PROFIsafe

ET 200S Failsafe motor starters

		Direct-on-line starters	Reversing starters
Control circuit			
Rated operational voltage for electronics U_1	V	24 DC (20.4 ... 28.8 DC)	24 (21.6 ... 26.4 DC)
Reverse polarity protection for electronics U_1		Yes	
Rated operational voltage for contactor U_2	V	24 DC (20.4 ... 28.8 V DC)	
Reverse polarity protection for contactor U_2		Yes	
Power consumption			
• From electronics supply U_1	mA	Approx. 40	Approx. 100
• From contactor supply U_2			
- Pickup	A	1.7 (for 80 ms)	--
- Hold	mA	Max. 350	--
• From SG1 up to 6			
- Pickup	mA	250 (for 200 ms)	
- Hold	mA	Max. 55	
• Test function of the shunt trip unit/starter protector (50 ms) from U_1	A	Approx. 1.5	
• From the backplane bus	mA	Approx. 20	
Main circuit			
Rated operational voltage U_e			
• Acc. to IEC 60947-1, EN 60947-1	V	500 AC	
• Protective separation between main and auxiliary circuits	V	400	
• UL, CSA	V	600 AC	
Rated insulation voltage U_i	V	500 AC	
Rated impulse withstand voltage U_{imp}	kV	6	
Rated frequency	Hz	50/60	

Dimensional drawings

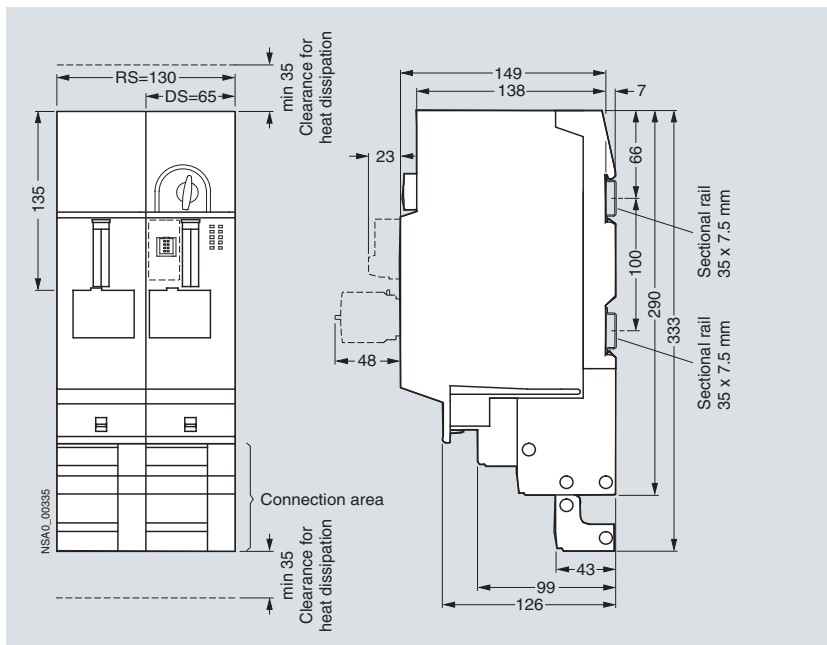

F-DS1e-x direct-on-line starter/F-RS1e-x reversing starter

For Operation in the Control Cabinet

ET 200S Safety Motor Starters Solutions local/PROFIsafe

Safety modules local

Overview

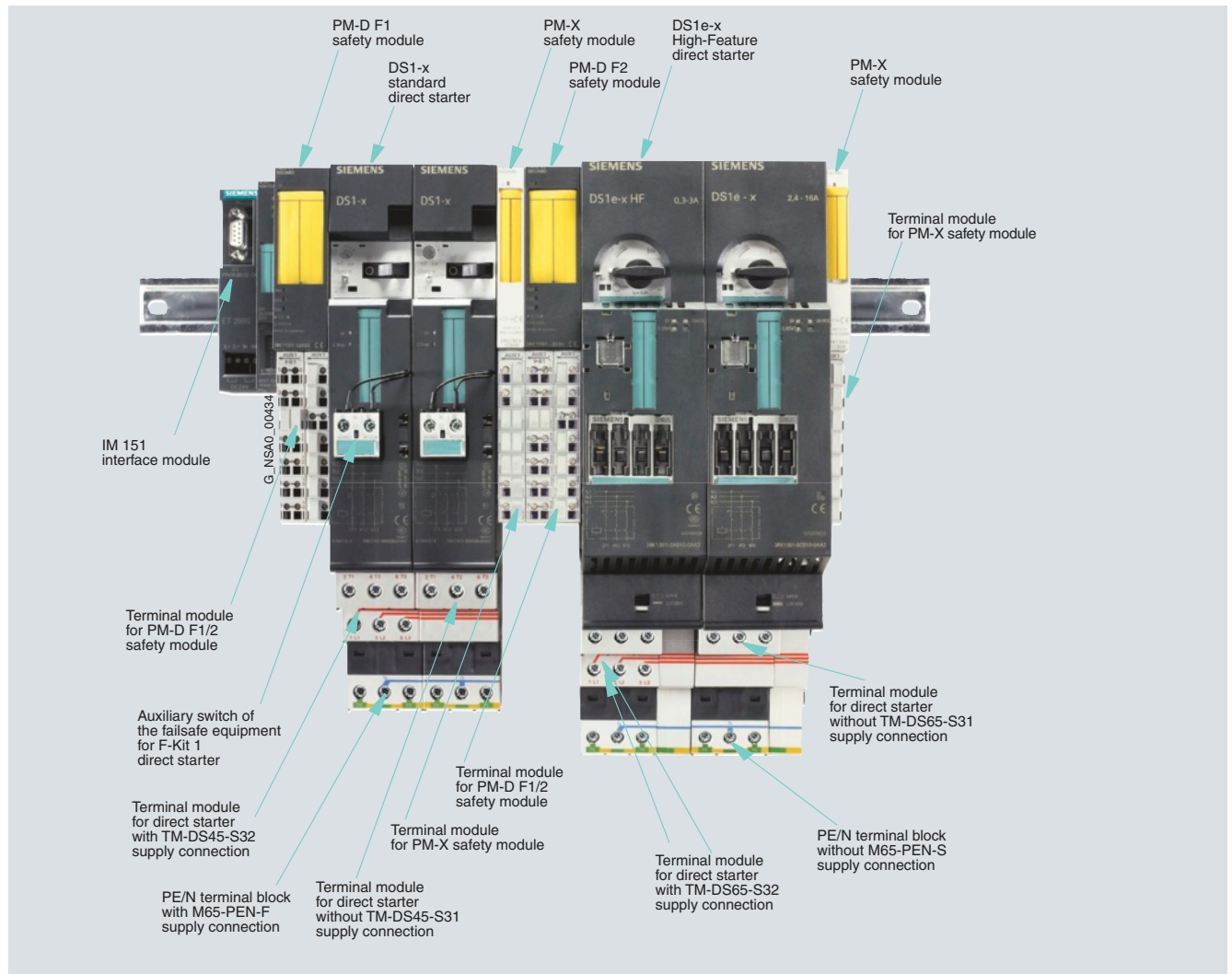

Interplay of ET 200S Safety motor starters Solutions local components



PM-D F1 safety module

Safety motor starters Solutions local

- For use of Standard, High-Feature or Failsafe motor starters in systems with safety categories 2 to 4 (according to EN 954-1)
- No complex wiring for conventional safety technology
- Can also be used in combination with external safety relays
- Can also be used to activate external safety systems
- Safety module available for function-monitored and automatic starting
- Safety module available for stop category 0 and 1
- Safety module for monitoring the auxiliary voltages for motor starters
- Safety modules can be plugged into the TM-PF30 terminal modules

For Operation in the Control Cabinet

ET 200S Safety Motor Starters Solutions local/PROFIsafe

Safety modules local

PM-D F1/F2/F3/F4/F5 safety modules

- PM-D F1/F2/F3/F4 safety modules monitor auxiliary voltages and contain the complete functionality of a safety relay:
 - PM-D F1
For evaluation of EMERGENCY-STOP circuits with the function "monitored start".
 - PM-D F2
For monitoring of protective doors with the function "automatic start".
 - PM-D F3
Expansion to PM-D F1/F2 for time-delayed disconnection.
 - PM-D F4
For expansion of safety circuits with other ET 200S motor starters, e. g. in a different line.
 - PM-D F5
Transmits the status from PM-D F1 ... 4 through four floating enabling circuits to external safety equipment (contact multiplier)
- The PM-D F1 and PM-D F2 modules can be combined with the PM-D F3 or PM-D F4 modules.
- A PM-D F5 can be positioned at any point between a PM-D F1 ... 4 and a PM-X.
- Safety modules monitor the U1 and U2 auxiliary voltages. A voltage failure is relayed as a diagnostic signal over the bus.
- No additional PM-D safety module is required when the safety modules are used.
- Each safety circuit, beginning with a PM-D F1 ... 4, must be terminated with one PM-X each.

Failsafe Kit

The Failsafe Kit (F-Kit) must be added to each Standard motor starter in a safety segment in order to monitor the switching function.

F-Kit 1 supplements the DS1-x direct-on-line starter, F-Kit 2 the RS1-x reversing starter.

The F-Kits are comprised of:

- Contact supports for the terminal modules
- One or two auxiliary switch blocks for the contactor/contactors of the motor starter
- Connecting cables

High-Feature motor starters and their terminal modules come as standard with the functionality of the F-Kits integrated.

Examples

The diverse possible uses of the Safety motor starters Solutions local are presented in the manual SIMATIC ET 200S motor starters in the context of typical sample applications.

Safety functional examples for easy, quick and low-cost implementations of applications with Safety motor starters Solutions local are available on the Internet:

You can find more information on the Internet at:

<http://www.siemens.com/sirius-starting>

<http://www.siemens.com/ET200S>

Example 1:

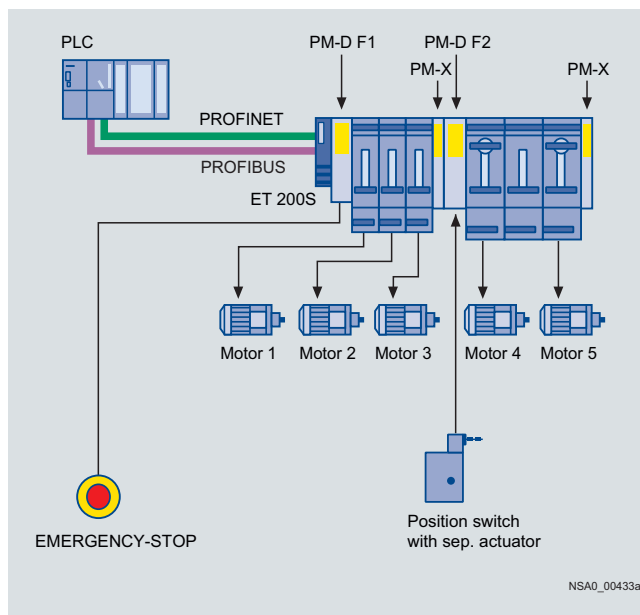

ET 200S Safety motor starters Solutions local with 2 safety circuits (= switch-off groups), standard motor starters and High Feature motor starters.

Example 2:

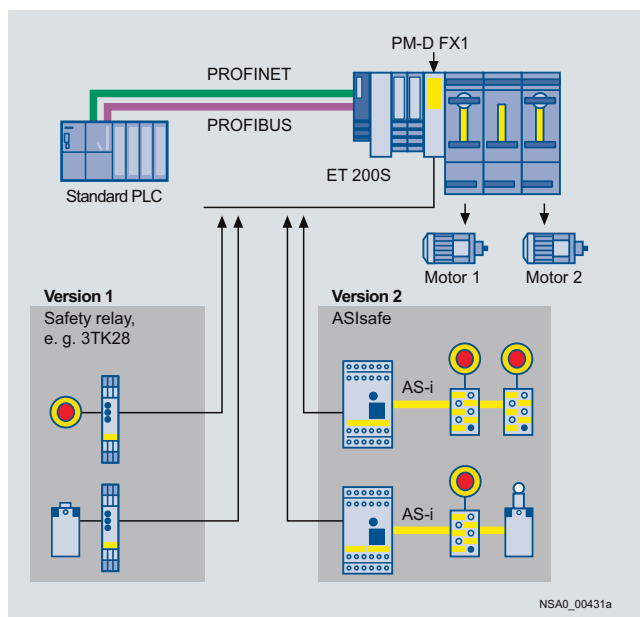

ET 200S Safety motor starters Solutions local with 2 external safety combinations (= safety relays or ASIsafe monitors) and with Failsafe motor starters (PM-DFX1 application). 2 of the 6 available safe switch-off groups are used.

Signals with relevance for safety can be input to ET 200S through a PM-DFX1 infeed terminal module through the enabling circuits of the ASIsafe monitor or the safety relay to control the Failsafe motor starters which then selectively switch off the downstream motors.

For Operation in the Control Cabinet

ET 200S Safety Motor Starters Solutions local/PROFIsafe

Safety modules local

Design

Components needed for applications with safety requirement

Components needed	Safety category acc. to EN 954-1			
	1	2	3	4
PM-D	X	--	--	--
PM-D F1/-F2/-F4	--	X	X	X
PM-D F3	--	X	X	--
F-Kit 1/2	--	X ¹⁾	X ¹⁾	X ¹⁾
PM-X	--	X	X	X
PM-DFX1	--	X	X	X
External infeed contactor	--	--	X	X

¹⁾ F-Kit needed only for Standard motor starter; already integrated in High-Feature motor starter.

Possible combinations of safety and terminal modules

Terminal module	PM-D F1	PM-D F2	PM-D F3	PM-D F4	PM-D F5	PM-X	PM-DFX1	FCM
TM-PF30 S47-B0	X	X	--	--	--	--	--	--
TM-PF30 S47-B1	X	X	--	--	--	--	--	--
TM-PF30 S47-C0	--	--	X	X	--	--	--	--
TM-PF30 S47-C1	--	--	X	X	--	--	--	--
TM-PF30 S47-D0	--	--	--	--	X	--	--	--
TM-X15 S27-01	--	--	--	--	--	X	--	--
TM-PFX30 S47-G0	--	--	--	--	--	--	X	--
TM-PFX30 S47-G1	--	--	--	--	--	--	X	--
TM-FCM30 S47	--	--	--	--	--	--	--	X

Terminal modules for safety modules

For supplying load and sensor voltage to the self-assembling potential bars of the Standard motor starters, High-Feature motor starters and frequency converters. Safety modules for voltage monitoring are plugged onto TM-P modules. TM-P modules can be used any number of times within the ET 200S. A safety module must always be plugged upstream from the first motor starter.

Different safety circuits can be functionally separated or else cascaded using different terminal modules. Each group in such a case must be terminated with a PM-X connection module.

TM-PF30 S47-B1

The terminal module is always positioned at the beginning of a safety segment and accommodates the PM-DF1 safety module for EMERGENCY-STOP applications or the PM-DF2 safety module for protective door monitorings. The 24 V supply voltages for the electronics (U1) and those for supplying the contactors (U2) of the motor starters must be connected along with the 2-channel connection of the safety sensors (e. g. EMERGENCY-STOP pushbuttons) to this terminal module. Connections for the ON button (enabling) and safe output of the safety module are available in addition.

TM-PF30 S47-B0

The terminal module is used to cascade lower level safety segments and accommodates the PM-DF1 safety module for EMERGENCY-STOP applications or the PM-DF2 safety module for protective door monitorings. No other auxiliary voltage has to be connected to this terminal module. The supply comes from the preceding PM-DF1 or PM-DF2 module over the potential bars of the terminal modules. Once the potential of the preceding safety module is disconnected, this sub-potential also has no voltage.

TM-PF30 S47-C1

The terminal module is always positioned at the beginning of a safety segment expansion in a new station, e. g. at an interlace point. It accommodates the PM-D F3 safety module for time-delayed shutdown or the PM-D F4 safety module for direct shutdown in separately located ET 200S stations. The 24 V supply voltages for the electronics (U1) and those for supplying the

contactors (U2) are fed in new.

The shutdown command from an upstream ET 200S station is received through a safe input. Separate terminals are available to connect the feedback circuit to the upstream ET 200S station. No safety sensors can be connected to this terminal module.

TM-PF30 S47-C0

The terminal module is used to cascade lower level safety segments and accommodates the PM-D F3 safety module for time-delayed shutdown or the PM-D F4 safety module. Only the U2 supply voltage for the contactors must be connected to this terminal module. The U1 supply comes from the preceding safety module (sub-potential group) over the potential bars of the terminal modules. No safety sensors can be connected to this terminal module.

TM-PF30 S47-D0

The terminal module is used to accommodate the PM-D F5 safety module. On this terminal module, safe signals can be relayed to external systems through four groups, each with two safety relay contacts configured with redundancy. The terminal module must always be positioned between one of the above mentioned terminal modules and a terminal module for the TM-X connection module. No safety sensors can be connected to this terminal module.

Terminal modules for connection modules (TM-X)

For connection of an external infeed contactor (second shutdown option) for category 3 and 4. The connection module is plugged on the right alongside the last motor starter of a safety segment. On the TM-X terminal module there are the terminals for connecting the positively driven NC contact of the contactors as well as the terminals for connecting the contactor coil. If no contactor with redundant switching is required, e. g. for category 2 (EN 954-1), the feedback circuit has to be closed at these terminals with a jumper. In applications with external safety relays it is also used instead of the safety module as interface to the external safety relay.

For Operation in the Control Cabinet

ET 200S Safety Motor Starters Solutions local/PROFIsafe

Safety modules local

Function

Safety motor starters Solutions local

The safety module evaluates the signal state of the connected safety sensors and, using the integrated safety relays, shuts down the group(s) of downstream motor starters. The shutdown function is monitored by the module, and the auxiliary voltages likewise.

Safety-relevant system signals, e. g. due to an actuated EMERGENCY-STOP switch or a missing auxiliary voltage, are automatically generated and notified to the interface module. The latter assigns an unambiguous ID to the fault. Using the PROFIBUS DP diagnostics module, faults of this type can be identified and localized without a great deal of programming work.

The PM-D F X1 safety module is used for feeding in 1 to 6 switch-off groups. The infeed voltage can be switched using 1 to 6 external safety shutdown devices (either ASIsafe monitors or 3TK28 safety shutdown devices). This safety module is used in applications with external safety shutdown devices where there is a need for the selective safety shutdown of failsafe motor starters (see example 2, page 6/125).

Terminal modules

Terminal modules for expansion modules (TM-xB)

The TM-xB terminal modules are used to accommodate the xB1, xB2, xB3 and xB4 brake control modules. The TM-terminal

module must always follow directly after a terminal module for Standard motor starters, High-Feature motor starters or frequency converters as control of the solid-state braking switch is provided through an output of the motor starter/frequency converter. The xB215 terminal modules for the brake control modules have not only the terminals for connecting the cable for the motor brake but also the terminals of the two local acting inputs. These local inputs are not evaluated by a frequency converter; for this reason the xB215 terminal module may be plugged in only downstream from a motor starter.

Terminal modules for (TM-PF30) safety module

For supplying load and sensor voltage to the potential bars of the motor starters, and for connection of the 2-channel sensor circuit (e. g. EMERGENCY-STOP pushbutton) and a reset button. Different terminal modules are available for the configuring of separate safety circuits or for the cascading of safety circuits, and for applications with time-delayed disconnection.

Terminal module for (TM-X) connection safety module

For connection of an external infeed contactor (2nd shutdown possibility). With terminals for contactor coil and feedback contact. Is always required to terminate a group of safety-oriented motor starters.

Technical specifications

PM-D F1, F2, F3, F4 and F5 safety modules		
Mechanical endurance	Operating cycles	10×10^6
Electrical endurance		200 000 with I_e
Utilization categories		DC-13
Control times		
• Minimum command duration	ms	200
• Recovery time	s	< 1
• Off-delay	ms	30
Control circuit U_1		
• Rated control supply voltage U_S	V	24 DC
• Operating range DC up to 60 °C		0.85 ... 1.2 x U_S
• Power consumption	W	2.4
• Recommended short-circuit protection		(gG) gL 2 A
• Output OUT+/OUT- for control of expansion modules		24 V DC/< 50 mA (PTC fuse)
Switched auxiliary circuit U_2		
• Rated control supply voltage U_S	V	24 DC
• Operating range DC up to 60 °C		0.85 ... 1.2 x U_S
• Rated operational current I_e (DC 13 ... 24 V)	A	4
• Conventional thermal current I_{th}	A	5
Recommended short-circuit protection for enabling and signaling circuits		Fuse links: LV HRC type 3NA DIAZED type 5SB NEOZED type 5SE gL (gG) operational class 6 A
Supplying		
• Motor starters		Yes
• Solid-state modules		No
• Ex(i) modules		No
• BG certification		Yes
• UL-, CSA certification		Yes
Cable length for EMERGENCY-STOP and ON pushbuttons	m	Max. 1000
Mounting dimensions (W x H x D)	mm	30 x 196.5 x 117.5 (incl. terminal module)
Enabling circuits with PM-D F5		4 (floating)

For Operation in the Control Cabinet

ET 200S Safety Motor Starters Solutions local/PROFIsafe

Safety modules local

PM-X safety modules						
Control circuit U_1						
• Rated control supply voltage U_S	V	24 DC				
Mounting dimensions (W x H x D)	mm	15 x 196.5 x 117.5 (incl. terminal module)				
Diagnostic signals with safety modules						
Fault type	Meaning	PM-D power modules				
		F1	F2	F3	F4	F5
01001: Fault	A module fault has occurred	X	X	X	X	X
10001: Sensor or load voltage missing	U_1 or U_2 not available or too low	X	X	X	X	X
11000: Actuator shutdown	Safety relay has dropped	X	X	X	X	X
11001: Safety-oriented disconnection	EMERGENCY-STOP has been actuated; crossover between the EMERGENCY-STOP cables has occurred	X	X	--	--	--
TM-PFX30 S47/TM-PF30 S47 terminal modules						
Dimensions						
Mounting dimensions (W x H x D)	mm	30 x 196.5 x 102				
Depth with power module	mm	117.5				
Insulation voltages and rated currents						
Insulation voltage	V	500				
Rated operational voltage	V	24 DC				
Rated operational current	A	10				
Conductor cross-sections						
Solid	mm ²	1 x (0.14 ... 2.5) acc. to IEC 60947 1 x (2.5)				
Finely stranded with end sleeve	mm ²	1 x (0.14 ... 1.5) acc. to IEC 60947				
AWG cables, solid or stranded	AWG	1 x (18 ... 22)				
Wiring						
Required tool		Standard screwdriver size 1				
Tightening torque	NM	0.4 ... 0.7				
PM-D FX1 safety modules (infeed terminal modules)						
Dimensions						
Mounting dimensions (W x H x D)	mm	30 x 196.5 x 117.5 (incl. terminal module)				
Module-specific specifications						
Ambient temperature	°C	0 ... +60				
Degree of protection		IP20				
Maximum achievable safety classes		SIL 3 Category 4				
• IEC 61508						
• EN 954-1						
Safety characteristics						
Proof-test interval		10 years				
Voltages, currents, potentials						
Rated control supply voltage U_S	V	21.6 ... 26.4 DC up to 60 °C				
Rated operational current I_e	A	6 Internal protection with 7 A melting fuse (quick)				
Recommended upstream short-circuit protection	A	Melting fuse gL/gG 6.3				
Supplying						
• Failsafe motor starters		Yes				
• Failsafe frequency converters		Yes				
• Solid-state modules		No				
• Ex[i] modules		No				
Power consumption						
• From the backplane bus	mA	≤ 10				
• From U_1	mA	≤ 35				
• From SGx	mA	≤ 15				
Status, alarms, diagnostics						
Alarms		None				
Diagnostics functions						
• Group fault/device fault		Red "SF" LED				
• Monitoring the supply voltage for solid-state modules U1 (PWR)		Green PWR LED				
• Monitoring of six switch-off groups		Green LED SG1 ... SG6				
• Diagnostics information can be read out		Yes				
Standards, approvals						
• TÜV		Yes				
• UL, CSA certification		Yes				

For Operation in the Control Cabinet

ET 200S Safety Motor Starters Solutions local/PROFIsafe

Safety modules local
F-CM contact multipliers
Dimensions

Dimensions (W x H x D) mm 30 x 196.5 x 117.5 (incl. terminal module)

Module-specific specifications

Number of relay outputs 4 (4 x 1-channel or 2 x 2-channel safe coupling/contact multiplication)

Internal power supply for bar U1 (from PM-D F/PM-D FX1)

Maximum achievable safety class

- Acc. to IEC 61508
- Acc. to EN 954

 SIL3
Cat. 4

Voltages, currents, potentials

 Switching capacity of the relay outputs Utilization category DC-13 (I_e/U_e):
1.5 A/24 V

Electrical separation

- Between outputs and backplane bus
- Between outputs and power supply
- Between outputs
- Between outputs/power supply and shield

 Yes
Yes
Yes
Yes

Status, alarms, diagnostics

Status display

PWR and STAT

Alarms: Diagnostics alarm

None

Diagnostics functions

Yes

- Group fault display
- Diagnostics information can be read out
- Monitoring the supply voltage for solid-state modules U_1 (PWR)
- Monitoring the switching state of the enabling circuit

 Red LED (SF)
Available
Green PWR LED
Red/green STAT LED

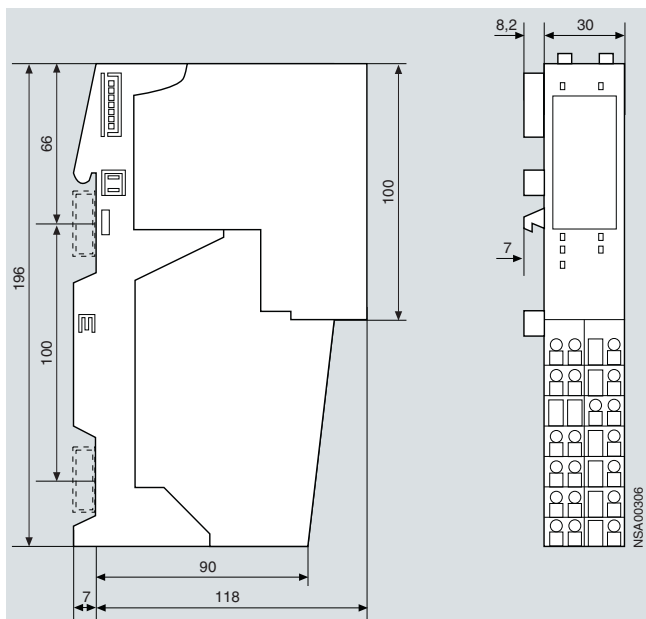
Dimensional drawings

PM-D F1 ... 4 safety module and TM-PF30 terminal module

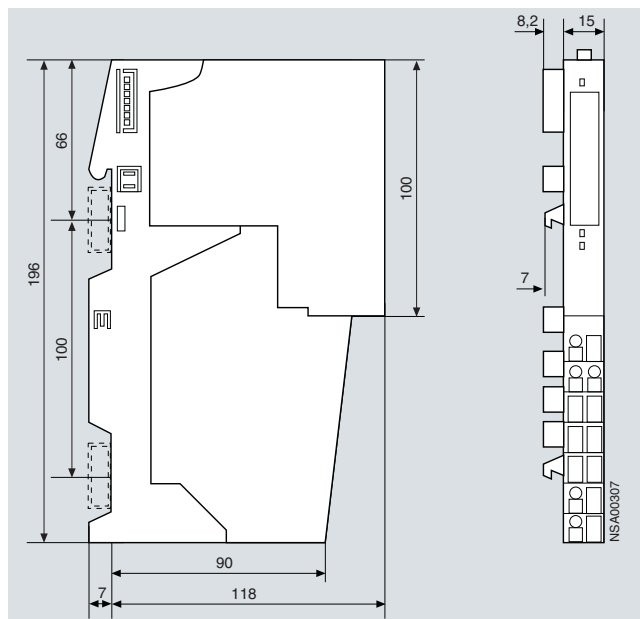

PM-X safety module and TM-X15 terminal module

For Operation in the Control Cabinet

ET 200S Safety Motor Starters Solutions local/PROFIsafe

Safety modules local

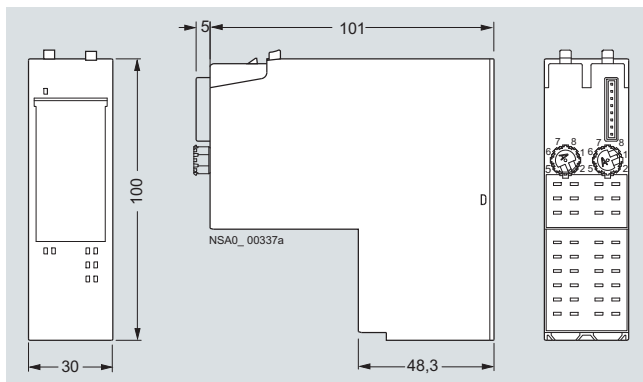

PM-D F X1 safety module (infeed terminal module)

Schematics

Terminal assignment TM-PFX30 S47-G0/G1 terminal modules (for PM-D F X1)

Terminal	Short designation	Meaning
1, 8	+ IN/OUT	U_1 : fused 24 V DC, limited to SIMATIC range
2, 9	M IN/OUT	
3, 10	--	Not assigned
4, 11	--	Not assigned
5, 12	--	Not assigned
6, 13	L+	U_{in} : for connecting an external power supply
7, 14	M	24 V DC SELP/PELV
--	AUX1	Is passed through without a terminal
15, 22	SG1	
16, 23	SG2	
17, 24	--	Not assigned
18, 25	SG3	
19, 26	SG4	
20, 27	SG5	
21, 28	SG6	

For Operation in the Control Cabinet

ET 200S Safety Motor Starters Solutions local/PROFIsafe

Safety module PROFIsafe

Overview

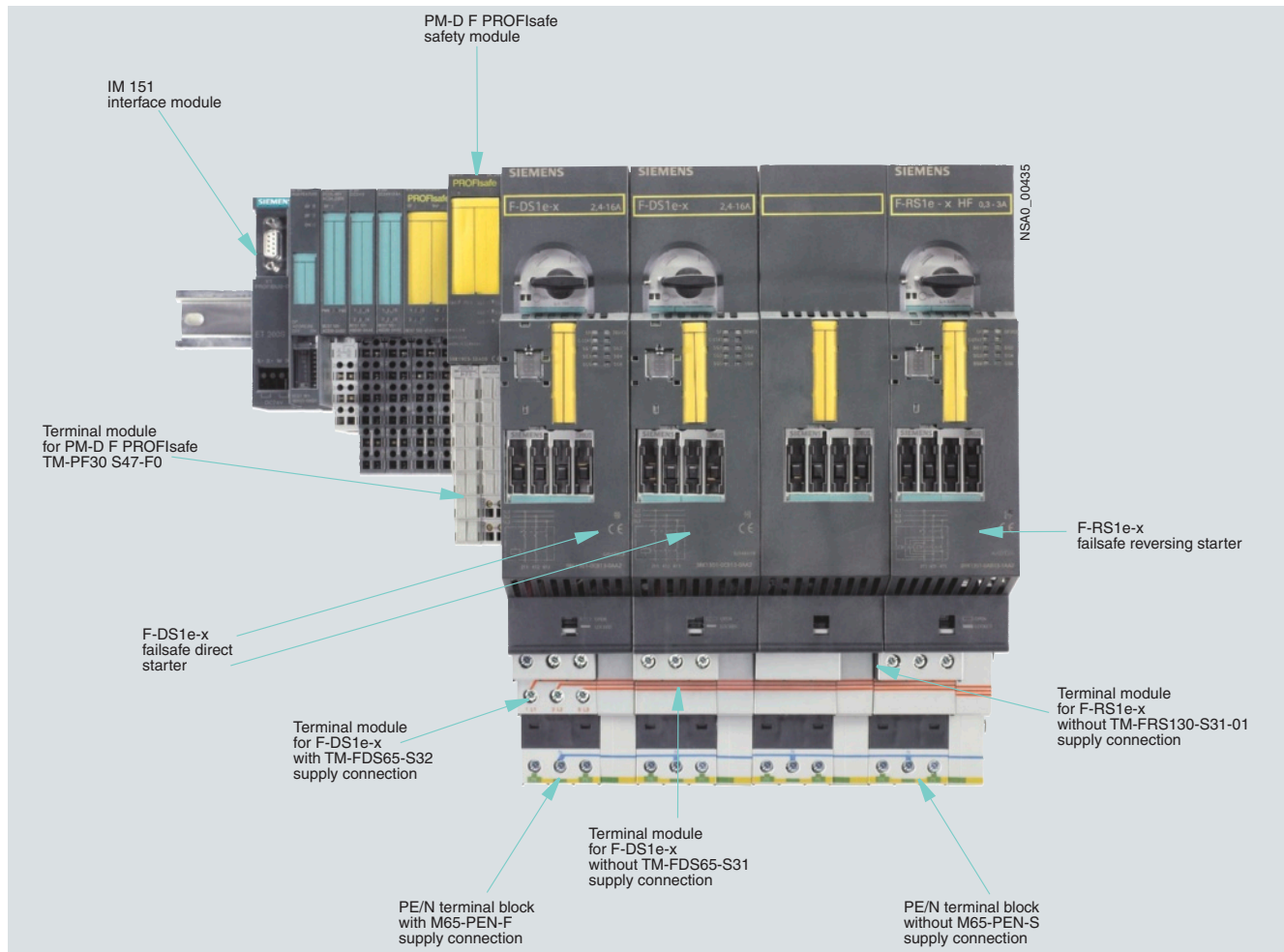

Interplay of ET 200S Safety motor starter Solutions PROFIsafe components

Safety motor starters Solutions PROFIsafe

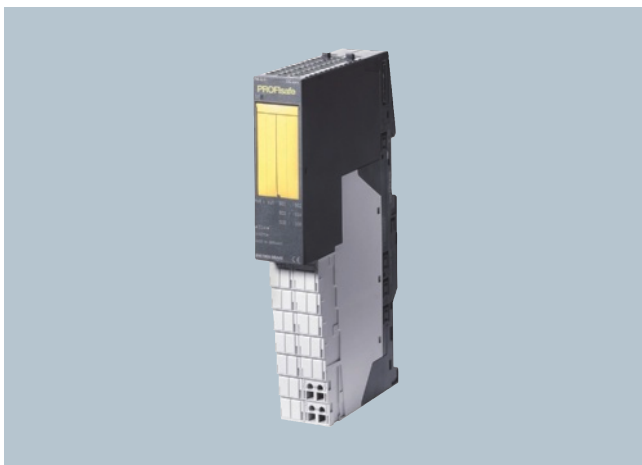

PM-D F PROFIsafe with TM-PF30 S47-F0 terminal module

Sensor and actuator assignment are freely configurable within the framework of the distributed safety concept:

The logic of the safety functions is implemented by software. Safety-oriented PROFIsafe communication and the use of a safety-oriented control system are required. Integration of the safety technology in the standard automation is realized through a single bus system (see Advantages of PROFIsafe), using PROFIBUS as well as PROFINET.

- For the use of Failsafe motor starters in plants with safety category 2 to 4 according to EN 954-1 and SIL 2 and 3 according to IEC 61508. The use of Standard or High-Feature motor starters is also possible with certain assemblies
- High flexibility (any assignment of sensors to motor starters using the PLC)
- Full selectivity of disconnection of the Failsafe motor starters
- No complex wiring for conventional safety technology, e. g. no infeed contactors even in the highest safety category
- Can also be used to activate external safety systems through F-CM contact multiplier
- Safety module available for any safety function
- Safety module available for stop category 0 and 1
- Safety module for monitoring the auxiliary voltages for motor starters
- Safety modules can be plugged into the TM-PF30 terminal modules

For Operation in the Control Cabinet

ET 200S Safety Motor Starters Solutions local/PROFIsafe

Safety module PROFIsafe

High degree of flexibility with safety technology Failsafe motor starters for PROFIsafe:

In EMERGENCY-STOP applications, the Failsafe motor starters are selectively switched off through the upstream PM-D F PROFIsafe safety module. For each safety module, six switch-off groups can be formed. In the first delivery stage, the failsafe freely-programmable logic of the SIMATIC controller is used to interface with the relevant Failsafe sensor technology. The interface between PROFIsafe and installations that use conventional safety technologies is implemented through the F-CM Failsafe contact multiplier with four floating contacts.

Example:

The diverse possible uses of the Safety motor starter Solutions PROFIsafe are presented in the manual SIMATIC ET 200S Motor Starters in the context of typical sample applications.

Safety functional examples for easy, quick and low-cost implementations of applications with safety motor starters Solution PROFIsafe are available on the Internet:

You can find more information on the Internet at:

<http://www.siemens.com/sirius-starting>

<http://www.siemens.com/ET200S>

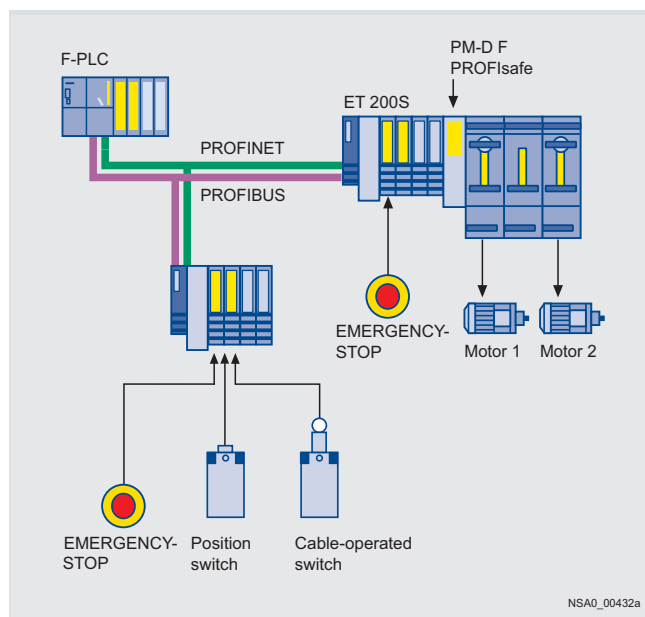

ET 200S Safety motor starters Solutions PROFIsafe with Failsafe motor starters and fully selective disconnection (PM-DF PROFIsafe application)

Within an ET 200S station the Failsafe motor starters are assigned to one of 6 safety segments. For plants with distributed configuration the shutdown signals of these safety segments are preferably issued by a higher-level, safety-oriented control system through PROFIsafe. This permits the greatest flexibility for assigning the motor starters to different safety circuits.

Alternatively, an ET 200S F-CPU can also be used for control purposes.

Function

Each safety module switches up to 6 switch-off groups for Failsafe motor starters/frequency converters.

The PM-D F PROFIsafe safety module receives the shutdown signal from the interface module of the ET 200S and safely switches off 1 to 6 switch-off groups. This safety module is used in PROFIsafe applications where there is a need for the selective safety shutdown of Failsafe motor starters/frequency converters.

The terminal assignment of the terminal modules for safe motor starters corresponds to the terminal assignment of the 45 and 65 mm terminal modules. The terminal modules for safe motor starters have a coding module in addition. This enables the safe motor starter to be assigned to one of the six switch-off groups.

The terminal module contains three coding elements which fully cover the three coding openings in the terminal module. The labeled coding element contains (in the chamber marked with the dash) the busbar tap; the non-labeled coding elements are used only to cover the coding openings. Switch-off group 1 (AG1 or SG1) is coded in the as-delivered state. The coding can be changed to switch-off group 2 by releasing the coding element and turning it through 180°. Changing the coding to switch-off group 3 is possible by exchanging the labeled and blank coding elements. In this case the dash on the labeled coding element must correlate with the dash of the required switch-off group (symbolized busbar).

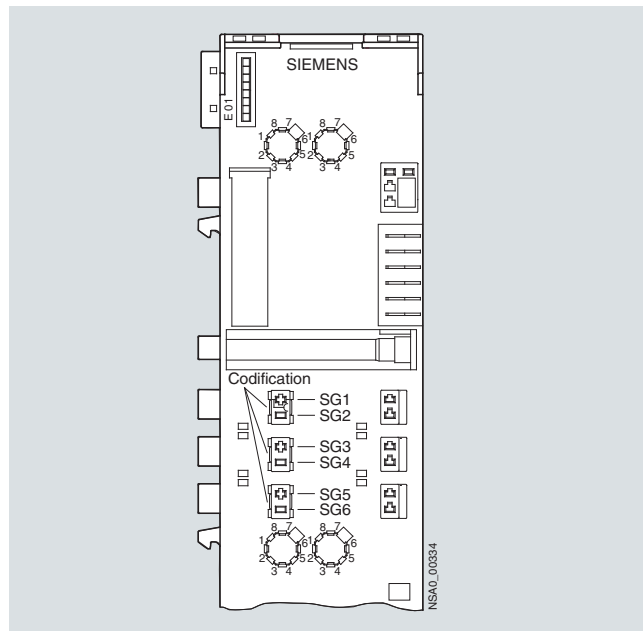

The Failsafe motor starters are assigned to one of the six possible switch-off groups.

For Operation in the Control Cabinet

ET 200S Safety Motor Starters Solutions local/PROFIsafe

Safety module PROFIsafe

Technical specifications

PM-D F PROFIsafe safety modules		
Dimensions		
Dimensions (W x H x D)	mm	30 x 196.5 x 117.5 (incl. terminal module)
Module-specific specifications		
Number of outputs, source input		6 switch-off groups (safety group 1 ... 6)
Internal power supply for bar		U1
Assigned address range		
• In PAE	byte	5
• In PAA	byte	5
Maximum achievable safety class		
• Acc. to IEC 61508		SIL3
• Acc. to EN 954		Cat. 4
Voltages, currents, potentials		
Supply voltage	V	24 DC
Electrical separation		
• Between outputs and backplane bus		Yes
• Between outputs and power supply		No
• Between outputs		No
• Between outputs/power supply and shield		Yes
Status, alarms, diagnostics		
Status display		Green LED per SG Green LED for electronics supply Green LED for load voltage
Alarms: Diagnostics alarm		"TO"
Diagnostics functions		
• Group fault display		Red LED (SF)
• Diagnostics information can be read out		available
Settings		
Module address		Diverse: 1. Using a safety-oriented parameter in the parameterization message frame over the backplane bus 2. Using the 10-pole DIL switch (binary-coded) on the left side of the module The received address is then compared with the DIL switch setting
F-CM contact multipliers		
Dimensions		
Dimensions (W x H x D)	mm	30 x 196.5 x 117.5 (incl. terminal module)
Module-specific specifications		
Number of relay outputs		4 (4 x 1-channel or 2 x 2-channel safe coupling/contact multiplication)
Internal power supply for bar		U1 (from PM-D F/PM-D FX1)
Maximum achievable safety class		
• Acc. to IEC 61508		SIL3
• Acc. to EN 954		Cat. 4
Voltages, currents, potentials		
Switching capacity of the relay outputs		Utilization category DC-13 (I_e/U_e): 1.5 A/24 V
Electrical separation		
• Between outputs and backplane bus		Yes
• Between outputs and power supply		Yes
• Between outputs		Yes
• Between outputs/power supply and shield		Yes
Status, alarms, diagnostics		
Status display		PWR and STAT
Alarms: Diagnostics alarm		None
Diagnostics functions		Yes
• Group fault display		Red LED (SF)
• Diagnostics information can be read out		Available
• Monitoring the supply voltage for solid-state modules U_1 (PWR)		Green PWR LED
• Monitoring the switching state of the enabling circuit		Red/green STAT LED

For Operation in the Control Cabinet

ET 200S Safety Motor Starters Solutions local/PROFIsafe

Safety module PROFIsafe

Dimensional drawings

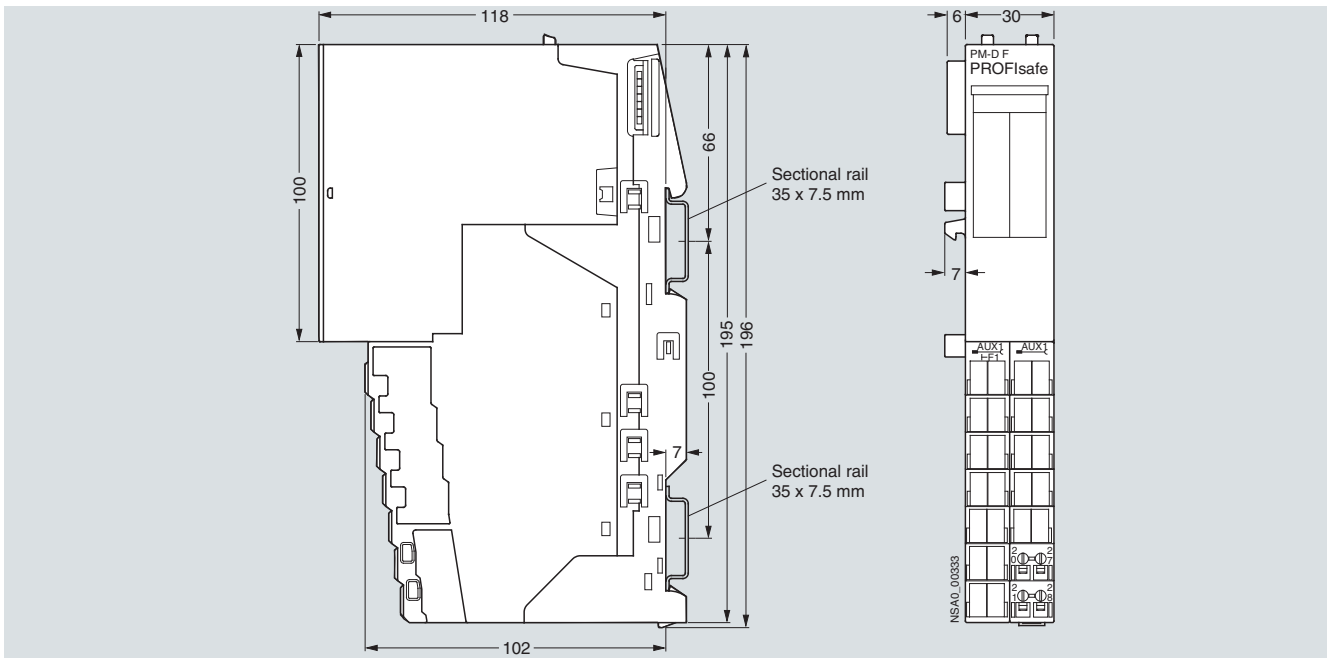

PM-D F PROFIsafe safety module with TM-PF30 terminal module

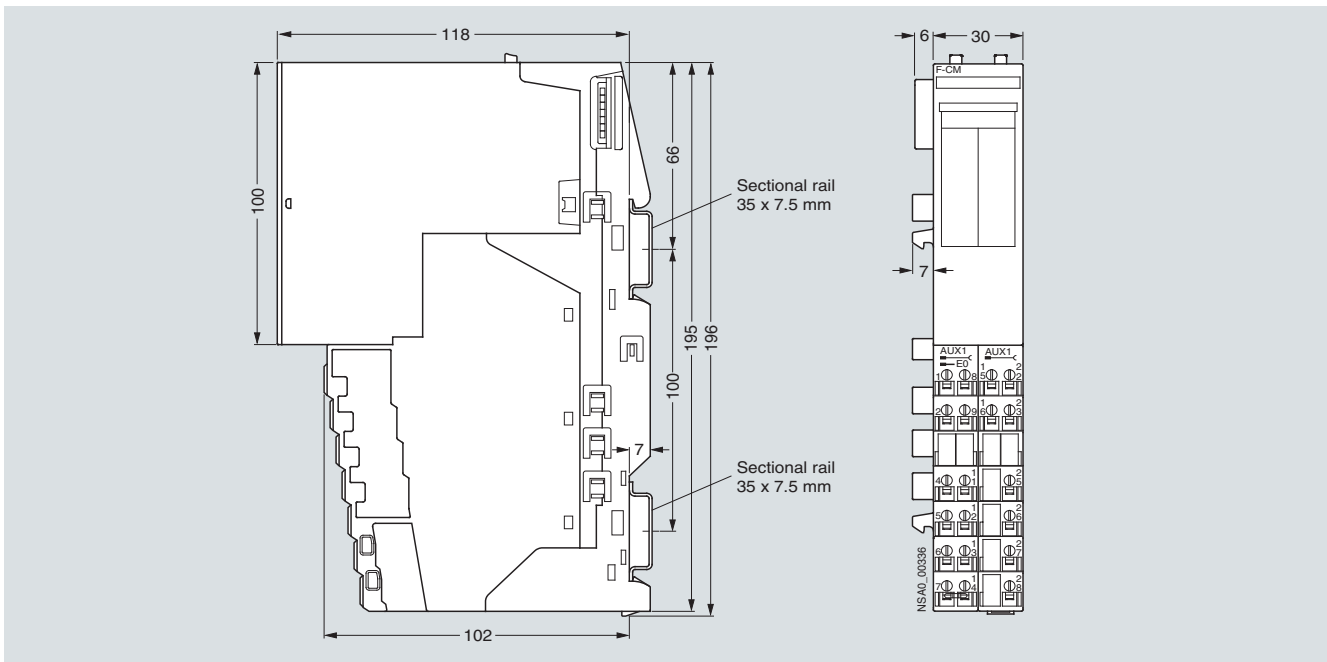

F-CM contact multiplier with TM-FCM30 terminal module

6

For Operation in the Control Cabinet

ET 200S Safety Motor Starters Solutions local/PROFIsafe

Safety module PROFIsafe

Schematics

Terminal assignment of TM-PF30 S47-F0 terminal module (for PM-DF PROFIsafe)

Terminal	Short designation	Meaning
20, 27	24 V DC	24 V DC infeed (terminals internally bridged)
21, 28	M	Infeed ground (terminals internally bridged)

Terminal assignment of TM-FCM30 S47-F01 terminal module (for F-CM)

The table shows the terminal assignment of the TM-FCM30 S47-F01 terminal module for the F-CM contact multiplier. The left half of the terminal module is used to assign the contact multiplier outputs to the desired switch-off group (safety group). It can be coded for only one safety group. The PM-D F treats multiple coding as crossover. The F-CM can also be configured in connection with the PM-D F X1 power module.

Terminal	Short designation	Meaning
1, 8	SG1	Jumper for coding to safety group 1
2, 9	SG2	Jumper for coding to safety group 2
4, 11	SG3	Jumper for coding to safety group 3
5, 12	SG4	Jumper for coding to safety group 4
6, 13	SG5	Jumper for coding to safety group 5
7, 14	SG6	Jumper for coding to safety group 6
15	OUT1.1	Floating relay output 1.1
16	OUT1.2	Floating relay output 1.2
22	OUT2.1	Floating relay output 2.1
23	OUT2.2	Floating relay output 2.2
25	OUT3.1	Floating relay output 3.1
26	OUT3.2	Floating relay output 3.2
27	OUT4.1	Floating relay output 4.1
28	OUT4.2	Floating relay output 4.2

For Operation in the Field, High Degree of Protection

ET 200pro Motor Starters

Standard and High-Feature

Overview



Motor starters

- Only two versions up to 5.5 kW
- All settings can be parameterized by bus
- Comprehensive diagnostic signals
- Overload can be acknowledged by remote reset
- Current unbalance monitoring
- Stall protection
- Emergency start function in the event of overload
- Current value transmission by bus
- Current limit monitoring
- Direct-on-line or reversing starters
- Power bus can be plugged in using the new HAN Q4/2 plug-in connectors
- Conductor cross-sections up to 6 x 4 mm²
- 25 A per segment (power looped through using jumper plug)
- In the Standard and High Feature versions (with 4 DI onBoard)
- Electromechanical switching and electronic switching
- Electronic starter for direct activation or with integrated smooth-starter function
- Supplied with 400 V AC brake contact as an option

Isolator modules

The isolator module with switch disconnecter function is used for safe disconnection of the 400 V operational voltage during repair work in the plant and provides an integrated group fusing function (i. e. additional group short-circuit protection for all subsequently supplied motor starters).

Depending on the power distribution concept, all stations can be equipped with an isolator module as an option.

Safety applications

Safety local isolator module

With the Safety local modules

- Safety local isolator module and
 - 400 V disconnecting module
- it is possible to achieve safety category 4/SIL 3 with an appropriate connection.

Safety Solution PROFIsafe

With the Safety PROFIsafe modules

- F-Switch and
- 400 V disconnecting modules

it is also possible to achieve safety category 4/SIL 3 with an appropriate connection.

Motor Starter ES software

The Motor Starter ES software is used for parameterization, monitoring, diagnostics and testing of motor starters.

See [Catalog LV 1, Chapter 12 "Planning and Configuration with SIRIUS"](#).

For Operation in the Field, High Degree of Protection

ET 200pro Motor Starters

Standard and High-Feature

Technical specifications

	Standard motor starters		High-Feature motor starters	
		DSe, RSe	DSe, RSe	sDSSSte, sDSte, sRSSSte, sRSte
General data				
Motor starters that can be connected to ET 200pro or modules with width of 110 mm		Max. 8		
Mounting dimensions (W x H x D)				
• Direct-on-line starter and reversing starter	mm	110 x 230 x 150		110 x 230 x 160
Permissible ambient temperature				
• During operation	°C	-25 ... +55, from +40 with derating		
• During storage	°C	-40 ... +70		
Permissible mounting positions		Vertical, horizontal		
Vibration resistance acc. to IEC 60068, Part 2-6		2 g		
Shock resistance to IEC 60068 Part 2-27		Half-sine 15 g/11 ms		
Power consumption	V DC	24		
• From auxiliary circuit L+/M (U1)	mA	Approx. 40		
• From auxiliary circuit A1/A2 (U2)	mA	Approx. 200		
Rated operational current for power bus I_e	A	25		
Rated operational voltage U_e	V AC	400		
• Approval acc. to EN 60947-1, Appendix N	V AC	Up to 400		Up to 400
• Approval acc. to CSA and UL	V AC	Up to 600		Up to 480
Approval to EN 61140	V	Up to 400		Up to 480
CSA and UL approval	V	Up to 600		Up to 480
Conductor cross-sections				
• Incoming energy supply	mm ²	Max. 6 x 4		
Degree of protection		IP65		
Touch protection		Finger-safe		
Degree of pollution		3, IEC 60664 (IEC 61131)		
Rated impulse withstand voltage U_{imp}	kV	6		
Rated insulation voltage U_i	V	400		
Rated operational current for starter I_e				
• AC-1/2/3 at 40 °C				
- At 400 V	A	0.15 ... 2.0/1.5 ... 12.0		0.15 ... 2.0/1.5 ... 12.0 ¹⁾
- At 500 V	A	0.15 ... 2.0/1.5 ... 9.0		
• AC-4 at 40 °C				
- At 400 V	A	0.15 ... 2.0/1.5 ... 4.0		
Rated short-circuit breaking capacity	kA	100 at 400 V		
Type of coordination to IEC 60947-4-1		1		
Power of induction motors at 400 V	kW	Max. 5.5		Max. 5.5/4 ²⁾
Utilization categories		AC-1, AC-2, AC-3, AC-4		AC-53a ³⁾ (max. 9 A with deactivated soft star function up to CLASS 10)
Protective separation between main and auxiliary circuits	V	400, acc. to EN 60947-1, Appendix N		
Endurance of contactor				
• Mechanical		30 million operating cycles		--
• Electrical		Up to 10 million operating cycles; dependent on the current loading (see Manual)		--
Reliable switching frequency		Dependent on the current loading, motor starting time and relative ON period (see Manual)		
Operating times at 0.85 ... 1.1 x U_e				
• Closing time	ms	11 ... 50		--
• Opening delay	ms	5 ... 45		--

- 1) **Caution!**
With deactivated soft starter control function the the permissible rated operational current is reduced to 9 A up to CLASS 10.
- 2) With parameterization as electronic starter max. 4 kW.
- 3) 8-hour operation.

For Operation in the Field, High Degree of Protection

ET 200pro Motor Starters

Standard and High-Feature

	Standard motor starters		High-Feature motor starters	
	DSe, RSe		DSe, RSe	sDSSt, sDSt, sRSSt, sRSt
Device functions				
Parameterizable rated operational current		Yes		
Parameterizable current limit values		No	Yes, 2 limit values	
Parameterizable response in case of current limit violation		No	Yes	
Zero current monitoring		Yes		
Parameterizable response in case of zero current violation		Yes		
Parameterizable current unbalance limit		No, fixed limit value (30 % × I _e)	Yes, 30 % ... 60 % × I _e	
Parameterizable response in case of unbalance limit violation		Yes		
Motor blocking monitoring		No	Yes	
Parameterizable blocking current limit		No	Yes, 150 % ... 1000 % × I _e	
Parameterizable blocking time limit	s	No	Yes, 1 ... 5	
Current value transmission		Yes		
Group warning diagnostics		No	Yes, parameterizable	
Group diagnostics		Yes, parameterizable		
Emergency start		Yes		
Digital inputs		No	Yes, 4 inputs	
• Parameterizable input signal		No	Yes, latching/ non-latching	
• Parameterizable input level		No	Yes, NC contacts/NO contacts	
• Parameterizable input signal delay	ms	No	Yes, 10 ... 80	
• Parameterizable input signal extension	ms	No	Yes, 0 ... 200	
• Parameterizable input control actions		No	Yes, 12 different actions	
400 V brake output		Yes, ordering option		
Parameterizable brake enabling delay	s	Yes, -2.5 ... 2.5		
Parameterizable holding time of the brake during stopping	s	Yes, 0 ... 25		
Parameterizable start-up type		No		Yes
Parameterizable ramp-down time		No		Yes
Parameterizable starting voltage		No		Yes
Parameterizable stopping voltage		No		Yes
Local device interface		Yes		
Firmware update		Yes, by trained personnel		
Thermal motor model		Yes		
Parameterizable trip class		No, CLASS 10 fixed	Yes, CLASS 5, 10, 15, 20	
Parameterizable response in case of overload of thermal motor model		No	Yes, 3 possible states	
Advance warning limit for motor heating	%	No	Yes, parameterizable 0 ... 95	
Advance warning limit time-related trip reserve	s	No	Yes, parameterizable 0 ... 500	
Parameterizable recovery time	min	No	Yes, 1 ... 30	
Parameterizable protection against voltage failure		No, permanently integrated	Yes	
Reversing start function		Yes, ordering option		
Parameterizable interlock time for reversing starters		No, 150 ms fixed	Yes, 0 ... 60 s	
Integrated logbook functions		Yes, 3 device logbooks		
Integrated statistics data memory		Yes		
Parameterizable response in case of CPU/master stop		Yes		
Device indications				
• Group fault		SF LED (red)		
• Switching state		STATE LED (red, yellow, green)		
• Device status		DEVICE LED (red, yellow, green)		
• Digital inputs		No	IN 1 ... IN 4, LED	

For Operation in the Field, High Degree of Protection

ET 200pro Motor Starters

ET 200pro isolator modules

Overview

The isolator module with integrated group fusing function (i. e. additional group short-circuit protection for all subsequently supplied motor starters) and switch disconnecter function is used for safe disconnection of the 400 V operational voltage in the plant.

Depending on the power distribution concept, all stations can be equipped with an isolator module as an option.

The isolator module is available in addition in a safety version. See Safety local Isolator Modules.

Function

The following properties apply to the isolator module:

- Increase of plant availability through fast replacement of units (easy mounting and plug-in technology)
- Cabinet-free construction thanks to high degree of protection IP65.

Technical specifications

		Isolator modules
General data		
Mounting dimensions (W x H x D)		
• Direct-on-line starter and reversing starter	mm	110 x 230 x 170
Permissible ambient temperature		
• During operation	°C	-25 ... +55
• During storage	°C	-40 ... +70
Permissible mounting positions		Any
Vibration resistance acc. to IEC 60068, Part 2-6		2 g
Shock resistance acc. to IEC 60068, Part 2-27		Half-sine 15 g/11 ms
Power consumption		
• From auxiliary circuit L+/M (U1)	mA	Approx. 20
• From auxiliary circuit A1/A2 (U2)		--
Rated operational current for power bus I_e	A	25
Rated operational voltage U_e	V	400
Approvals acc. to		
• EN 61140	V	Up to 500
• CSA and UL	V	Up to 600
Conductor cross-sections		
• Incoming energy supply	mm ²	Max. 6 x 4
Degree of protection		IP65
Touch protection		Finger-safe
Degree of pollution		3, IEC 60664 (IEC 61131)
Rated impulse withstand voltage U_{imp}	kV	6
Rated insulation voltage U_i	V	400
Rated operational current for starters I_e		
• AC-1/2/3 at 40 °C		
- At 400 V	A	25
- At 500 V	A	25
Rated short-circuit breaking capacity	kA	50 at 400 V
Type of coordination to IEC 60947-4-1		2
Protective separation between main and auxiliary circuits	V	400, acc. to IEC 61140
Device functions		
• Group diagnostics		Yes, parameterizable
Device indications		
• Group fault		SF LED (red)

For Operation in the Field, High Degree of Protection

ET 200pro Motor Starters

Safety modules

Overview



Safety local isolator module

The Safety local isolator module is a repair switch with integrated safety evaluation functions that can be parameterized using DIP switches.

It is used for:

- Connection of a 1 or 2-channel EMERGENCY-STOP circuit up to category 3-4/SIL 3 (protective door or EMERGENCY-STOP pushbuttons) and parameterizable start behavior
- Control of the 400 V disconnecting module by means of a safety rail signal

400 V disconnecting modules

The 400 V disconnecting module enables the safe disconnection of the operational voltage of 400 V up to Category 3-4/SIL 3. For operation in a Safety Solution local application it functions only in combination with the Safety local isolator module.

For operation in a Safety PROFIsafe application it functions only in combination with the F-Switch.

F-Switch

Fail-safe digital inputs/outputs in degree of protection IP65/66/67 for near-machine, cabinet-free use.

Fail-safe digital inputs

- For the failsafe reading in of sensor information (1-/2-channel)
- Including integrated evaluation for 2v2 signals
- Internal sensor supplies (incl. testing) available

Fail-safe digital outputs

- 3 failsafe PP-switching outputs for safe switching of the backplane bus bars

The F-Switch is certified up to Cat. 4 (EN 954-1) and up to SIL 3 (IEC 61508) and has detailed diagnostics.

It supports PROFIsafe in PROFIBUS configurations as well as in PROFINET configurations.

Function

Safety local isolator module

The module with local safety function is designed for the following individual functions:

- Functions as for the isolator module, plus:
 - 2 safe inputs for:
 - EMERGENCY-STOP or protective door contacts, 2-channel
 - Monitored start
 - 2 slide switches for adjusting the basic functions
 - 1-/2-channel
 - Autostart/monitored start.

400 V disconnecting modules

The 400 V disconnecting module is designed for the following individual functions:

- Double disconnection of the main circuit supply (Cat. 4/SIL 3)
- Feedback of the module's functional state over bus.

For Operation in the Field, High Degree of Protection

ET 200pro Motor Starters

Safety modules

Technical specifications

		Safety local isolator modules	400 V disconnecting modules
General data			
Mounting dimensions (W x H x D) in mm			
• Direct-on-line starter and reversing starter	mm	110 x 230 x 170	110 x 230 x 150
Permissible ambient temperature			
• During operation	°C	-25 ... +55	
• During storage	°C	-40 ... +70	
Permissible mounting positions		Any	
Vibration resistance to IEC 60068, Part 2-6		2 g	
Shock resistance to IEC 60068 Part 2-27		Half-sine 15 g/11 ms	
Power consumption			
• From auxiliary circuit L+/M (U1)	mA	Approx. 20	
• From auxiliary circuit A1/A2 (U2)		--	
Rated operational current for power bus I_e	A	25	
Rated operational voltage U_e	V	400	
Approval to EN 61140	V	Up to 500	
CSA and UL approval	V	Up to 600	
Conductor cross-sections			
Incoming energy supply	mm ²	Max. 6 x 4	
Degree of protection		IP65	
Touch protection		Finger-safe	
Degree of pollution		3, IEC 60664 (IEC 61131)	
Rated impulse withstand voltage U_{imp}	kV	6	
Rated insulation voltage U_i	V	400	
Rated operational current for starter I_e			
• AC-1/2/3 at 40 °C			
- At 400 V	A	16	25
- At 500 V	A	16	25
Rated short-circuit breaking capacity	kA	50 at 400 V	
Type of coordination to IEC 60947-4-1		2	
Protective separation between main and auxiliary circuits	V	400, acc. to EN 61140	
Operating times at 0.85 ... 1.1 x U_e			
• Closing time	ms	--	25 ... 100
• Opening delay	ms	--	7 ... 10
Device functions			
• Group diagnostics		Yes, parameterizable	
Device indications			
• Group fault		SF LED (red)	

For Operation in the Field, High Degree of Protection

AS-Interface Compact Starters, 400 V AC

General data

Overview



The AS-Interface compact starter is a load feeder with degree of protection IP65, which is fully prewired inside, for switching and protecting any AC loads up to 5.5 kW at 400/500 V AC (electromechanical compact starter) or up to 2.2 kW (solid-state compact starter) – mostly standard induction motors in direct start and reversing duty. It consists either of an electromechanical controlgear combination or a solid-state overload protection and switching unit. The overload or short-circuit protection is located below a sealable, transparent cover and is therefore available for diagnostics. Two LEDs are provided to the left of the cover for diagnostics purposes for the AS-Interface and the auxiliary power.

It is not possible for live parts to be touched even when the cover is open. The contacts are activated through the integrated outputs. The status of the device is scanned through the inputs, e. g. feedbacks from the auxiliary contacts of the motor starter protector and contactor(s). A further input is used to detect the operating mode of the optional hand-held device. The three power connectors are used to feed and loop through to the load supply voltage (power bus) and to connect to the load itself. Prefabricated power supply cables can be used to connect compact starters which are directly adjacent to each other. Prefabricated power supply lines can be used to connect compact starters which are directly adjacent to each other. The maximum number of starters that can be supplied with one power supply cable is limited by the maximum permissible summation current (up to max. 4 mm² corresponds to ~ 35 A).

DS/RS compact starters (electromechanical)

The electromechanical compact starters consist of a conventional controlgear combination with a SIRIUS motor starter protector for protection against short-circuits and overloading and SIRIUS contactor(s) for normal switching. The advantages of the electromechanical starters are the reliable isolation during disconnection and tripping, the integrated fuseless protection against short-circuits and the favorable price. What is more, direct currents can also be switched with the electromechanical starters.

Configuring note:

In the case of temperature-critical applications, we recommend operation in the lower setting range of the motor starter protector.

EDS/ERS compact starters (solid-state)

The solid-state compact starters EDS (direct-on-line starter) and ERS (reversing starter) consist of a solid-state overload relay and a solid-state motor starter protector unit.

The advantages of these solid-state compact starters are the broad limits within which the overload protection can be adjusted (the performance range up to 2.2 kW at 400/500 V AC is covered with just 2 versions), the fact that the switching units are non-wearing, current measurement (used for monitoring the energy connector), emergency operation in the event of an overload as well as remote resetting via the AS-Interface after overload tripping.

The ERS compact starter is designed for direct start in reversing duty. The solid-state overload protection and the shutdown response in the event of overload can be adjusted directly at the device.

Version with brake contact

All compact starters are available optionally with a separately activated brake contact for electrically operated motor brakes. For externally fed motor brakes, 24 V DC is supplied jointly with the load voltage through the power connector on -X1. It is looped through via -X3 for supplying the next compact starter on -X1. The 24 V DC supply for the brakes is only linked in those devices equipped with a brake contact. At the project configuration stage, it is important to ensure that these starters are located alongside each other.

All compact starters with a brake contact for 500 V DC can be equipped with an 400 AC brake contact.

Hand-held device

The hand-held device enables the compact starter to be operated locally and autonomously, providing that the auxiliary voltage supply is connected. Thus, assuming that the automation level is functioning correctly, local switching operations can be carried out in addition to normal manual operations in the event of a programmable controller / bus system failure (emergency mode) or during test runs before commissioning, e. g. for testing the direction of rotation of the motor. The hand-held device can be connected to the compact starter by means of a connecting cable through a socket underneath the transparent cover.

Spare inputs

The compact starters are also equipped with two spare inputs.

The M12 socket is a "Y" connector. The signal inputs are applied to PIN 2 and 4. In this manner, it is possible, for example, to connect an optical proximity switch that supplies a signal and the "contamination" alarm.

A "T" adapter can be used to split the signal inputs onto two M12 sockets. Compact starters modified in this way offer additional advantages. At no extra cost, it is possible to save AS-Interface addresses, reduce the space requirement and to build up logical groupings.

Design

Wiring and mounting

All terminals are for plugging in or designed for the user-friendly insulation piercing method.

The shaped flat cable for the 24 V load voltage to actuate the contactors must simply be inserted (like the AS-Interface data line) in a mounting plate. Then the compact starter is hung in the mounting plate and screwed tight. Compact starters and mounting plates must be ordered separately. The energy for the main circuit is supplied through power connectors which must also be ordered separately (see "Accessories" in "Selection and ordering data").

For Operation in the Field, High Degree of Protection AS-Interface Compact Starters, 400 V AC

General data

The load itself and other compact starters are supplied with the help of the same connector system. This enables all supply and data lines to be routed like a bus through the installation. While the switching devices are switched by the load voltage through the outputs, the inputs are supplied through the AS-Interface data line. With this separate auxiliary voltage supply it is easy to implement selective Emergency-Stop concepts.

Addressing

The addressing of the AS-Interface compact starter is also possible in the fully wired state. When the addressing cable is plugged into the addressing socket, the starter is separated from the AS-Interface network.

Function

Indication behavior

During operation, the LEDs on the compact starter indicate the following device states:

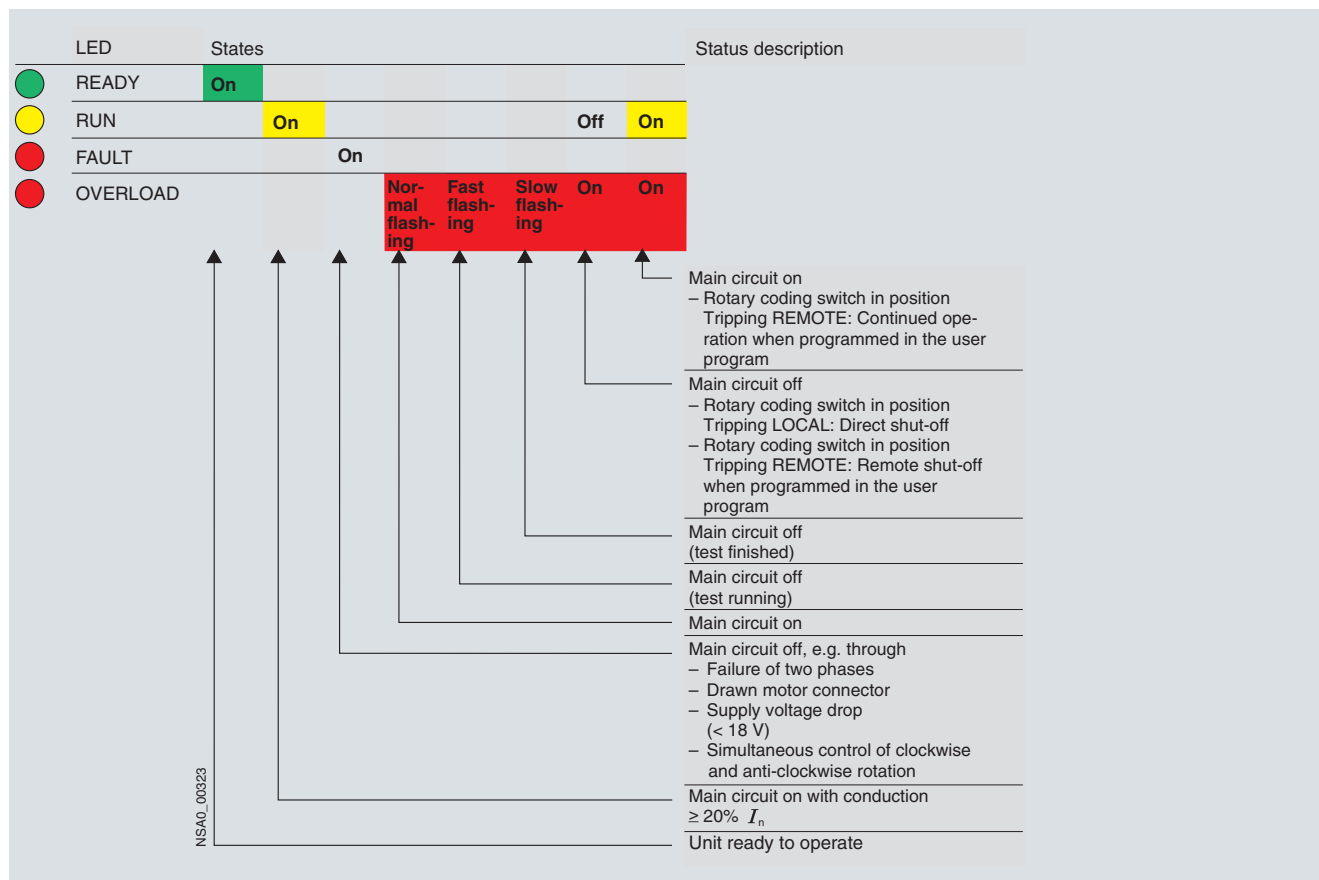
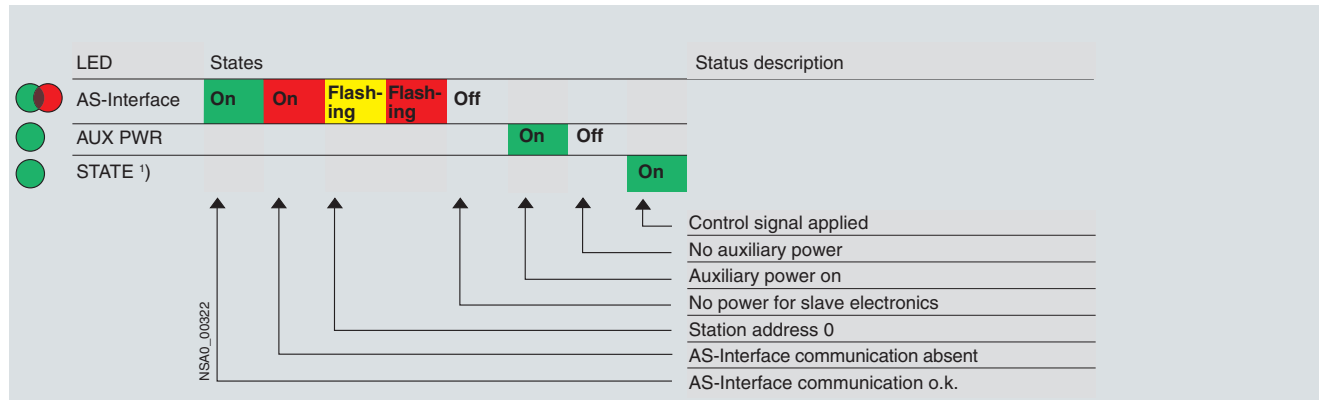

For Operation in the Field, High Degree of Protection

AS-Interface Compact Starters, 400 V AC

General data

Diagnostics of the electromechanical compact starters via the user program

The input and output signals of the electromechanical compact starters DS2E and RS2E can be evaluated in the user program.

Output DO2 is actuated only in the case of versions with brake contact.

The I/O assignment corresponds to the AS-Interface motor starter profile 7D.

Note:

The brake contact is controlled through the bus separately to the main circuit. The non-synchronous switching of motor and brake is thus possible. Therefore, steps must be taken in the user program to ensure that no dangerous plant states can arise, e. g. unwanted freewheeling or blocking of the motor. This also applies to local disconnections, e. g. by overload tripping. The DI0 input signal can be used to check the device state.

Inputs

Input signals		Device status		Meaning
DI0	"Ready"	0	Device not ready/error	Manual operation Device was switched locally to manual operation (use the hand-held device to switch back to automatic mode). Overload and short-circuit release Reclosing of the motor starter protector after a cooling phase. FAULT signal <ul style="list-style-type: none"> • Coil defective. • Contacts welded. • Output driver defective (contactor must be tested). • Simultaneous switching of clockwise and counterclockwise operation (user program must be checked).
		1	Device ready/automatic mode	--
DI1	"Running"	0	Contactors off	--
		1	Contactors on	--
DI2	"Special information 1"	0	No input signal IN1	--
		1	Input signal IN1	--
DI3	"Special information 2"	0	No input signal IN2	--
		1	Input signal IN2	--

Outputs

Output signals		Device status		Meaning
DO0	"Run forward"	0	Clockwise off	--
		1	Clockwise on	--
DO1	"Run reserve"	0	Counterclockwise off	--
		1	Counterclockwise on	--
DO2	"Special command 1"	0	Open brake contact	--
		1	Close brake contact	--
DI3	"Special command 2"	0	--	--
		1	--	--

For Operation in the Field, High Degree of Protection

AS-Interface Compact Starters, 400 V AC

General data

Diagnostics of the solid-state compact starters via the user program

The input and output signals of the solid-state compact starters EDS2E and ERS2E can be evaluated in the user program.

Output DO2 is actuated only in the case of versions with brake contact.

The I/O assignment corresponds to the AS-Interface motor starter profile 7E.

Note:

The brake contact is controlled through the bus separately to the main circuit. The non-synchronous switching of motor and brake is thus possible. Therefore, steps must be taken in the user program to ensure that no dangerous plant states can arise, e. g. unwanted freewheeling or blocking of the motor. This also applies to local disconnections, e. g. by overload tripping. The DI0 input signal can be used to check the device state.

Inputs

Input signals			Device status	Meaning
DI0	"Ready"	0	Device not ready/error	Manual operation Device was switched locally to manual operation (use the hand-held device to switch back to automatic mode). Tripped signal Rotary coding switch in position <ul style="list-style-type: none"> • Tripping LOCAL: direct switching off • Tripping REMOTE: remote switching off or continued operation when programmed accordingly in the user program
		1	Device ready/automatic mode	--
DI1	"Running"	0	No current flow	--
		1	Current flow exists	--
DI2	"Special information 1"	0	No input signal IN1	--
		1	Input signal IN1	--
DI3	"Special information 2"	0	No input signal IN2	--
		1	Input signal IN2	--

Outputs

Output signals			Device status	Meaning
DO0	"Run forward"	0	Clockwise off	--
		1	Clockwise on	--
DO1	"Run reserve"	0	Counterclockwise off	--
		1	Counterclockwise on	--
DO2	"Special command 1"	0	Open brake contact	--
		1	Close brake contact	--
DI3	"Special command 2"	0	Remote RESET off	--
		1	Remote RESET on	--

For Operation in the Field, High Degree of Protection

AS-Interface Compact Starters, 400 V AC

General data

Technical specifications

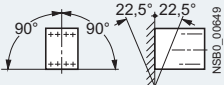
	DS/RS	EDS/ERS
Degree of protection	IP65 (with closed connection elements and cover)	
Material	Thermoplast (glass-fiber reinforced)	
Color	Anthracite RAL 7016	
Cover	Latching, sealable	
Dimensions (W x H x D)	mm	120 x 265 x 134
Temperature range		
• Operating temperature	°C	-25 ... +55; (note derating: see manual)
• Storage temperature	°C	-40 ... +70
Permissible mounting positions		
Shock resistance		
Rectangular pulse	g/ms	2/unlimited, 10/5 or 5/10
Sine pulse	g/ms	2/unlimited, 8/10 or 5/15
External power supply		
For output supply (contact control)	V DC	24 (PELV – must be grounded)
Rated operational voltage U_e		
For electronics and inputs (feedback of controlgear states) using AS-Interface data line	V DC	26.5 ... 31.6 (acc. to AS-Interface Specification)
I/O configuration	Hex	7
ID code	Hex	D
AS-Interface power consumption	mA	Max. 100
Power consumption U_{aux}	mA	Approx. 170
Watchdog function (disconnects outputs in the event of AS-Interface fault)	Built-in	
Diagnostics		
Using AS-Interface	Feedback from motor starter protectors and contactor(s) through positively driven auxiliary contacts and separate inputs	
Through LED on the enclosure	Auxiliary voltage applied AS-Interface communication OK AS-Interface communication faulty Station address = 0 (module not addressed)	
Through LED on the hand-held device	On or Clockwise or Counterclockwise	
Main circuit		
Rated operational voltage	V AC	500 acc. to EN 61140, 600 acc. to CSA and UL
Protective separation between main and auxiliary circuits (acc. to EN 61140)	V	Up to 400
Rated power	kW	5.5
Permissible operating modes		Uninterrupted duty, temporary duty, periodic duty, periodic intermittent duty (50 % relative ON period at 80 1/h at 5.5 A)
Permissible switching frequency with a starting time $t_A = 0.1$ s and a relative ON period $t_{OP} = 50$ %	1/h	≤ 80
Trip class		Class 10
Conductor cross-sections of power connector for infeed/feeder/9-pole loop	mm ²	≤ 4, AWG (15 ... 11)
Max. permissible current through power connector (dependent on cable cross-section)		
• $T_u = 60$ °C	A	30 (4 mm ²), AWG (11); 20 (2.5 mm ²), AWG (15); 12 (1.5 mm ²), AWG (13)
• $T_u = 40$ °C	A	35 (4 mm ²), AWG (11); 25 (2.5 mm ²), AWG (15); 15 (1.5 mm ²), AWG (13)
Short-circuit strength of the starter combination	kA	65 (acc. to type of coordination "1")
Electrical endurance of the motor starter protector element under load I_a (AC-3)	Operating cycles	See endurance characteristic curves of the 3RT10 contactors
		≥ 10 million

For Operation in the Field, High Degree of Protection AS-Interface Compact Starters, 400 V AC

General data

Dimensional drawings

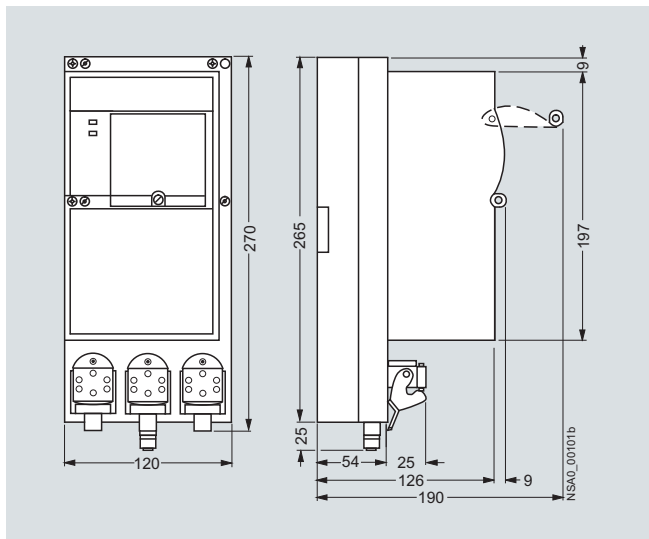

3RK1 322-..S.-.AA

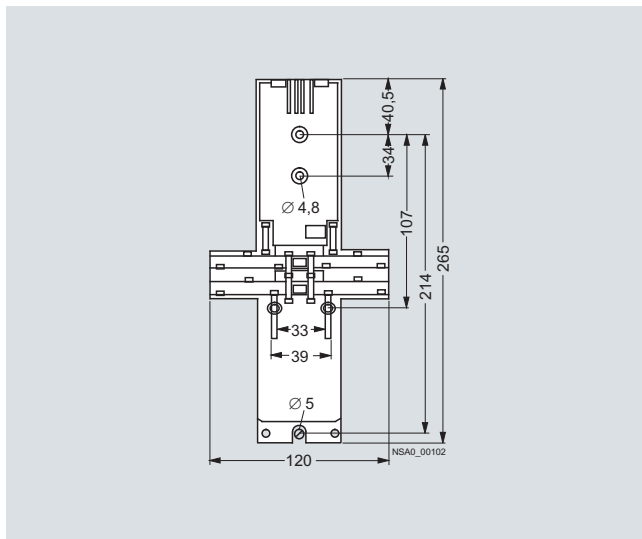

3RK1 902-0AP00

Schematics

Connector assignment for digital inputs (Y assignment)

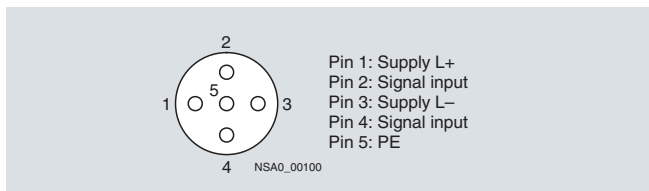

Connector assignment for power connectors

X1: Power infeed (plug of the starter)	X2: Load feeder (socket of the starter)	X3: Power loop-through connection (socket of the starter)
<p style="text-align: center;">-X1</p>	<p style="text-align: center;">-X2</p>	<p style="text-align: center;">-X3</p> <p style="text-align: right; font-size: small;">NSAO_00348a</p>
<p>Pin 1: Not assigned Pin 2: Phase L2 Pin 3: Spare Pin 4: GND for brake¹⁾ optional Pin 5: + DC 24 V for brake¹⁾ optional Pin 6: Phase L1 Pin 7: Not assigned Pin 8: Phase L3 Center: PE</p>	<p>Pin 1: Phase L1 Pin 2: Not assigned Pin 3: Phase L3 Pin 4: Brake output Pin 5: Brake input Pin 6: Not assigned Pin 7: Phase L2 Pin 8: Not assigned Center: PE</p>	<p>Pin 1: Not assigned Pin 2: Phase L2 Pin 3: Spare Pin 4: + DC 24 V for brake¹⁾ Pin 5: GND for brake¹⁾ Pin 6: Phase L3 Pin 7: Not assigned Pin 8: Pin 1: Phase L1 Center: PE</p>
<p>1) Only for AS-Interface compact starters with DC 24 V brake contact (3RK1 322-..S.-.AA1).</p>		

For Operation in the Field, High Degree of Protection

ECOFAST Motor Starters and Soft Starters

3RK1 3 ECOFAST motor starters and soft starters

Overview



Distributed motor starters are used for switching and protecting loads locally. Versions with graded functional scope and with different installation possibilities ensure that both the functional requirements of the process and the constructional boundary conditions of the machine or installation are taken into account. Distributed motor starters are available for PROFIBUS DP and AS-Interface.

The starters can be installed close to the motor or mounted on the motor.

The following are available

- Single devices for geographically distributed motors and
- Isolated solutions (ET 200pro) for operating mechanisms installed close together.

The functionality in the ECOFAST system ranges from direct-on-line starters, to reversing starters and soft starters through to frequency converters.

Brake contacts are available as an option for the starters. Two or four integrated digital inputs enable sensors to be scanned locally.

All starters are equipped throughout with standardized interfaces for data and energy according to the ECOFAST specification:

- HanBrid for PROFIBUS DP and insulation piercing method for AS-Interface
- Han Q4 for the power supply
- Han 10e for motor connection

The starters can be connected using T pieces for data and T terminal connectors for power to prevent interruption.

The 3RK1 922-3BA00 hand-held device is also available for local operation (see Catalog LV 1, ET 200S Motor Starters).

Motor Starter ES software

The Motor Starter ES software is used for parameterization, monitoring, diagnostics and testing of motor starters. See Catalog LV 1, Chapter 12 "Planning and Configuration with SIRIUS".

Technical specifications

		3RK1 3 ECOFAST motor starters	
General data			
Location		On the plant Near the motor Motor plugged on	
• Wall mounting			
• Mounting directly on the motor			
Mounting position		Any	
Degree of protection		IP65	
Safety class		1, supply with protective extra-low voltage	
Acc. to IEC 61140			
Cooling		Convection, no addition cooling necessary	
Weight			
• Reversing starters	kg	1.4	
• Reversing soft starters	kg	1.9	
Permissible ambient temperature			
• Operation	°C	-20 ... +40; condensation not permitted!	
- Reversing and reversing soft starters up to max. +55 °C		Over 40 °C: Reduction of I_e by 1.5 %/K	
• Storage/transport	°C	-40 ... +80	
Relative air humidity	%	5 ... 95; condensation not permitted!	
Installation altitude, max.		2000 m; above 1000 m: Reduction of I_e by 1 %/100 m	
Vibratory load		f = 5 ... 26 Hz; d = 0.75 mm: 10 cycles f = 26 ... 150 Hz; a = 2 g	
Shock		a = 150 m/s ² (15 g) with 11 ms, for every 3 shocks in all axes (=18)	
ESD			
• Air discharge, acc. to IEC 61000-4-2, degree of severity 3	kV	8	
• Contact discharge	kV	6	
Electromagnetic fields	V/m	10	
IEC 61000-4-3, degree of severity 3			
BURST			
• Supply voltage, IEC 61000-4-4, degree of severity 3	kV/kHz	2/5	
• Data lines	kV/kHz	1/5	
• Process lines	kV/kHz	2/5	
Emitted interference, acc. to EN 55011		Limit value class A	

For Operation in the Field, High Degree of Protection

ECOFAST Motor Starters and Soft Starters

3RK1 3 ECOFAST motor starters and soft starters

		Unswitched voltage 24 V DC (AS-i)	Switched voltage 24 V DC (AUX PWR)
Auxiliary power			
External auxiliary power			
• PROFIBUS DP	V DC	20.4 ... 28.8 standard power supply unit acc. to DIN 19240	20.4 ... 28.8 standard power supply unit acc. to DIN 19240
• AS-Interface	V DC	23.0 ... 31.5 (AS-i)	unit acc. to DIN 19240 (PELV must be grounded)
Power consumption			
• Typical, inputs not connected	mA	80 (PROFIBUS DP)	--
	mA	60 (AS-Interface)	--
• Typical, switching element (contactor) activated	mA	--	75
• Typical, switching element (contactor) deactivated	mA	--	15
• Typical, with Duo reversing soft starters	mA	--	110
Pole reversal protection		Yes	
Short-circuit protection/overload protection		Yes	
		Multifuse 0.5 A, self-restoring fuse	
		Reset by Power-OFF	
Undervoltage detection (USP)	V DC	< 17	
Voltage failure bridging	ms	≤ 20, (device is not affected)	
Insulation voltage	V DC	500 between the auxiliary voltages and PE	
3RK1 3 ECOFAST motor starters			
Digital inputs			
Input voltage	V DC	20.4 ... 28.8	
Power consumption			
• Typical, per input	mA	7	
Sensor supply			
From AS-i, sensor supply is short-circuit resistant	mA	Max. 200	
Brake output 400 V AC			
Voltage range	V AC	200 ... 460	
• Tolerance	%	± 10	
Current carrying capacity			
• AC-15	mA	500	
Short-circuit protection			
Melting fuse, $I_{Cu} = 1 \text{ kA}$	A	aM 1/500 V AC	
Primary power			
Rated operational voltage	V AC	400	
Tripping times acc. to IEC 60947-4-1 at 7.2 times I_e			
• Class 10	s	8, acc. to standard 4 ... 10	
• Class 20	s	16	
• Class 30	s	24	
Rated insulation voltage acc. to IEC 60947-1	V AC	500	
Rated impulse voltage acc. to IEC 60947-1	kV	4	
Protective separation between auxiliary and primary power	V AC	300	
Frequency	Hz	50 ... 60	
• Tolerance	%	± 10	
ON period	%	100	
Utilization categories		1 (device destroyed after short-circuit)	
Current measurement			
Measuring accuracy	%	± 7.5 of parameterized rated operational current	
Measuring range		10 times the parameterized rated operational current	

For Operation in the Field, High Degree of Protection

ECOFAST Motor Starters and Soft Starters

3RK1 3 ECOFAST motor starters and soft starters

		3RK1 3 ECOFAST motor starters	
		Mechanical switching	Solid-state switching of reversing soft starters
Operational voltage	V AC	200 ... 460; 3-phase	200 ... 460; 3-phase
• Tolerance	%	±10	±10
Operational current			Performance class
			3 6
• Class 10	A	0.3 ... 9	0.3 ... 3 2.4 ... 12
• Class 20	A	0.3 ... 7.3	0.3 ... 3 2.4 ... 7.3
• Class 30	A	0.3 ... 6.7	0.3 ... 3 2.4 ... 6.7
Operating mode			
Output			
• Voltage	V AC	--	--
• Current	A	--	--
• Frequency	Hz	--	--
• Apparent power	kVA	--	--
Pulse frequency		--	--
Current limiting			
• Motorized/regenerative		--	--
Braking resistance		--	--
Switching capacity			
• AC-3	A	9.0	--
• AC-53	A	--	3 (0.3 ... 3) 12 (2.4 ... 12) ¹⁾
• AC-4	A	6.5	3 (0.3 ... 3) 12 (2.4 ... 12) ¹⁾
Switching load		3-phase with contactor	2-phase with thyristors
Max. heat sink temperature	°C	--	+80 ²⁾
Short-circuit protection			
Melting fuse	A	$I_{Cu} = 120$ kA aM 16/500 V AC	$I_{Cu} = 120$ kA aM 16/500 V AC
Endurance of the switching element			
Per direction of rotation at 500 V AC			
•	Operat- ing cycles	--	8×10^6
• At $I_e = 9.0$ A	Operat- ing cycles	0.4×10^6	--
• At $I_e = 4.5$ A	Operat- ing cycles	1.1×10^6	--
• At $I_e = 3.0$ A	Operat- ing cycles	2.5×10^6	--
• At $I_e = 1.5$ A	Operat- ing cycles	7.0×10^6	--
Waiting time t_{off}	ms	≥300	≥500
Time between opening command and the next closing command at a change of direction			

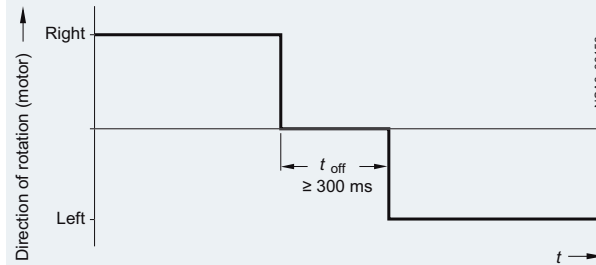

1) Max. 9 A when soft starter control function is deactivated.

2) The heat sink temperature is monitored; switch-off occurs if the maximum value is exceeded.

For Operation in the Field, High Degree of Protection ECOFAST Motor Starters and Soft Starters

3RK1 3 ECOFAST motor starters and soft starters

Dimensional drawings

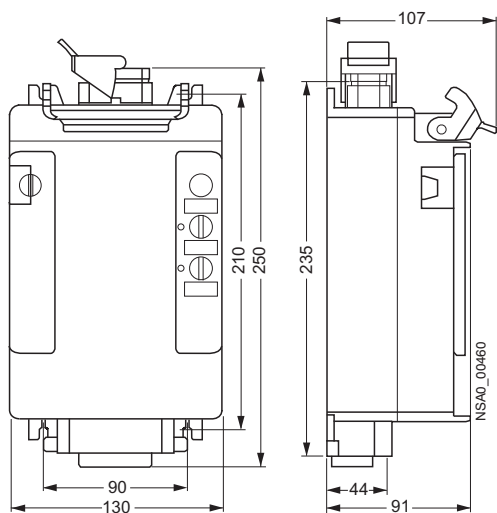

Reversing starter PROFIBUS DP with plastic base

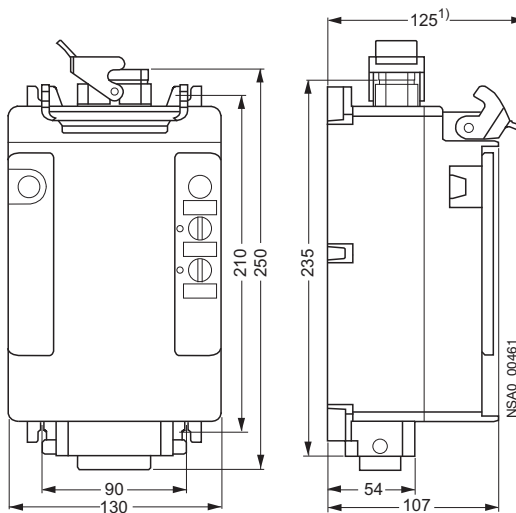

Reversing soft starter with metal base

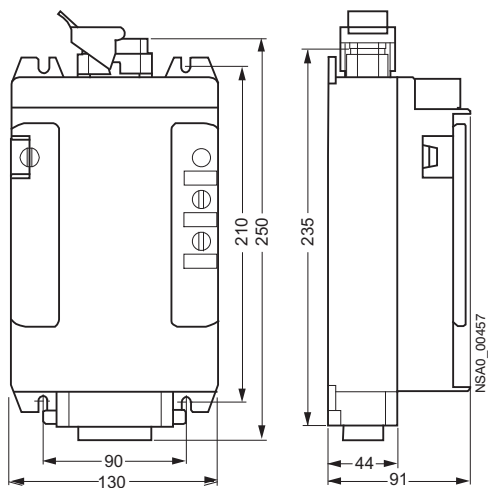

Reversing starter AS-Interface with plastic base

¹⁾ This dimension does not apply for motor starters with AS-Interface.

For Operation in the Field, High Degree of Protection

3RE Encapsulated Starters

General data

Overview



The 3RE1 encapsulated starters are available as direct-on-line starters and as reversing starters.

Direct-on-line starter

The direct-on-line starters are available in three sizes:

- Size **S00** is suitable for induction motors up to 5.5 kW with 400 V AC and a maximum rated motor current of 12 A. The starters are available in the following two versions:
 - Molded-plastic enclosure for direct-on-line starters including contactor – in this case the overload relay must be selected and ordered according to the rated motor current.
 - Molded-plastic enclosure for direct-on-line starters (without contactor) – in this case the contactor and overload relay must be selected and ordered separately.
- Size **S0** is suitable for induction motors up to 11 kW with 400 V AC and a maximum rated motor current of 25 A. The starters are available in the following two versions:
 - Molded-plastic enclosure for direct-on-line starters including contactor – in this case the overload relay must be selected and ordered according to the rated motor current.
 - Molded-plastic enclosure for direct-on-line starters (without contactor) – in this case the contactor, auxiliary switch and overload relay must be selected and ordered separately.
- Size **S2** is suitable for induction motors up to 22 kW with 400 V AC and a maximum rated motor current of 50 A. The starters are available in the following versions:
 - Molded-plastic enclosure for direct-on-line starters (without contactor) – in this case the contactor, auxiliary switch and overload relay must be selected and ordered separately.

Reversing starter

The reversing starters are available in two sizes:

- Size **S00** is suitable for induction motors up to 5.5 kW with 400 V AC and a maximum rated motor current of 12 A. The starters are available in the following two versions:
 - Molded-plastic enclosure for reversing starters including contactor assembly – in this case the overload relay must be selected and ordered according to the rated motor current.
 - Molded-plastic enclosure for reversing starters (without contactor assembly) – in this case the contactor assembly, auxiliary switch and overload relay must be selected and ordered separately.
- Size **S0** is suitable for induction motors up to 11 kW with 400 V AC and a maximum rated motor current of 25 A. The starters are available in the following versions:
 - Molded-plastic enclosure for direct-on-line starters (without contactor assembly) – in this case the contactor assembly, auxiliary switch and overload relay must be selected and ordered separately.

Design

Components

The 3RE1 encapsulated starters consist of a 3RT10 contactor or 3RA13 contactor assembly (fully mounted) for switching, a 3RU11 thermal overload relay for inverse-time delayed protection, auxiliary switch(es) and molded-plastic enclosure including the necessary actuators.

Mounting options

There are two options for mounting the 3RE1 encapsulated starters:

- The first option is to use a 3RE10 direct-on-line starter or a 3RE13 reversing starter consisting of a molded-plastic enclosure with actuators, integrated contactor or integrated contactor assembly and auxiliary switches. Only the overload relay (to be ordered separately) needs to be mounted on the contactor or contactor assembly. Wiring is carried out quickly and easily according to the schematics thanks to prefabricated cabling.
- The second option is to use a 3RE19 molded-plastic enclosure with integrated actuators. The contactor or contactor assembly, which is available fully mounted or in the form of individual components for self-assembly, the auxiliary switches (in the case of the size S00 direct-on-line starter these are already integrated in the contactor) and the overload relay must be ordered separately. In this case, too, the overload relay is mounted directly on the contactor or contactor assembly and wired up. The complete assembly is snapped onto the standard mounting rail in the molded-plastic enclosure.

For Operation in the Field, High Degree of Protection

3RE Encapsulated Starters

General data

In the case of the second mounting option, the following components must be ordered:

	Components for mounting	Size	Order No.	Number	Alternative components for mounting	Size	Order No.	Number
Direct-on-line starters Size S00	Molded-plastic enclosure	S00	3RE19 13-1CB1	1				
	Contactors with integrated auxiliary switch 1 NO	S00	3RT10 1-....1	1				
	Thermal overload relay	S00	3RU11 16	1				
Direct-on-line starters Size S0	Molded-plastic enclosure	S0	3RE19 23-1CB2	1				
	Contactors	S0	3RT10 2	1				
	Thermal overload relay	S0	3RU11 26	1				
	Lateral auxiliary switches 1 NO/1 NC	--	3RH19 21-1DA11	1				
Direct-on-line starters Size S2	Molded-plastic enclosure	S2	3RE19 33-1CB3	1				
	Contactors	S2	3RT10 3	1				
	Thermal overload relay	S2	3RU11 36	1				
	Lateral auxiliary switches 1 NO/1 NC	--	3RH19 21-1DA11	1				
Reversing starters Size S00	Molded-plastic enclosure	S00/S0	3RE19 13-2CB3	1				
	Contactors	S00	3RT10 1	2	Reversing contactor assembly	S00	3RA13 17-8XC17-0..	1
	Wiring kit for reversing contactor assemblies	S00	3RH19 13-2A	1				
	Thermal overload relay	S00	3RU11 16	1				
	Front auxiliary switches 1 NO	--	3RH19 11-1BA10	2				
Reversing starters Size S0	Molded-plastic enclosure	S00/S0	3RE19 13-2CB3	1				
	Contactors	S0	3RT10 2	2	Reversing contactor assembly	S0	3RA13 2-8XB30-0..	1
	Wiring kit for reversing contactor assemblies	S0	3RH19 23-2A	1				
	Mechanical interlock	--	3RH19 24-2B	1				
	Thermal overload relay	S00	3RU11 26	1				
	Front auxiliary switches 1 NO	--	3RH19 21-1CA10	2				

Function

The 3RE1 encapsulated starters, which are available as direct-on-line starters and reversing starters, are used for the switching and inverse-time delayed protection of loads. The switching of loads is taken care of by 3RT10 contactors. Inverse-time delayed protection is achieved with 3RU11 thermal overload relays.

These starter combinations consisting of a contactor or contactors and overload relay(s) are contained in a molded-plastic enclosure that provides effective protection against dust and splashwater with its high degree of protection IP65. This high degree of protection also applies to the actuators, which are used for manual switching on and off locally.

Control circuit

The encapsulated starters including contactor or contactor assembly are available with the following rated control supply voltages:

- Size S00: 230 V, 50/60 Hz and 400 V, 50/60 Hz
- Size S0: 230 V, 50 Hz and 400 V, 50 Hz

Short-circuit protection

Fuses (fused construction) or motor starter protectors (fuseless construction) are to be used for short-circuit protection.

Details of the assignment of appropriate short-circuit devices for the combinations of 3RT contactor with 3RU11 thermal overload relay are given in the technical specifications.

When the load feeders are selected from the table, the types of coordination must also be taken into account.

Overload protection

Detailed information about the 3RU11 thermal overload relays (e. g. about recovery time, trip classes, tripping characteristics and phase failure protection) is given in the corresponding sections relating to Protection Equipment: Overload relays -> 3RU1 thermal overload relays.

Manual/automatic resetting

In the case of the size S00 and S0 direct-on-line starters, a choice can be made between automatic and manual resetting on the overload relay. If manual resetting is chosen, the black button (O) is also the reset button. This button must be actuated after an overload trip before the load can be restarted.

The only type of resetting possible with the other starters is an automatic reset.

Details about setting the overload relays to automatic/manual resetting are given in the corresponding section describing the overload relays.

Switching on and off

With the direct-on-line starters, the load is switched on using the white button (I). The black button (O) is used for switching the load off.

With the reversing starters, the load can be started in the relevant direction of rotation by turning the upper switch clockwise or anticlockwise, as appropriate. The direction of rotation can be changed by pressing the black button (O).

For Operation in the Field, High Degree of Protection

3RE Encapsulated Starters

General data

Technical specifications

	3RE1. 10 3RE19 13	3RE1. 20 3RE19 23	3RE1. 30 3RE19 33
General data			
Standards			
• IEC 60947-1, EN 60947-1	Yes		
• IEC 60947-5, EN 60947-5	Yes		
• IEC 60947-2, EN 60947-2	Yes		
Size	S00	S0	S0
Max. rated current $I_{n \max}$ = (Max. rated operational current I_e)	A	12	25
Rated insulation voltage U_i (degree of pollution 3)	V	400	50
Rated impulse withstand voltage U_{imp}	kV	4	
Ambient temperature			
• Operation	°C	-20 ... +35 (current reduction is necessary above +35 °C)	
• Storage	°C	-55 ... +80	
Degree of protection acc. to IEC 60947-1	IP65		
Touch protection acc. to EN 50274	Finger-safe		
Installation altitude	m	Up to 2000 above sea level; above this, please enquire	
Permissible rated current I_n			
• Overload relay for ambient temperature: +35 °C	%	100	
• Overload relay for ambient temperature: +45 °C	%	87	
Mounting position	For installation in the hatched area, a setting correction of 10 % must be implemented. Contactor + overload relay		
Conductor cross-sections	1)		
Short-circuit protection			
Main circuit	2)		
Auxiliary circuit	1)		

1) See Chapter 5, "Protection Equipment" → "Overload Relays" → "3RU1 Thermal Overload Relays".

2) When using the 3RU11 thermal overload relays, see "Selection of Overload Relays and Short-Circuit Protection", pages 6/155 and 6/156.

For Operation in the Field, High Degree of Protection

3RE Encapsulated Starters

General data

Selection of overload relays and short-circuit protection

With short-circuit currents up to 50 kA at 400 V, 50/60 Hz
Permissible short-circuit protection for encapsulated motor

starters comprising contactor/contact assembly and overload relay

Size S00		Fuses for type of coordination "1" ¹⁾ ToC 1				Fuses for type of coordination "2" ¹⁾ ToC 2				Motor starter protectors for type of coordination "2" ¹⁾ ToC 2
Setting range	3RU11 thermal overload relay	5.5 kW = 3RE1. 10-8XC17 (3RT10 17 contactor) $I_{e \max} = 12 \text{ A}$ (at 400 V, 50/60 Hz)				5.5 kW = 3RE1. 10-8XC17 (3RT10 17 contactor) $I_{e \max} = 12 \text{ A}$ (at 400 V, 50/60 Hz)				at $I_G = 50 \text{ kA/400 V, 50/60 Hz}$
		gL/gG		BS88		gL/gG		BS88		
A		A	A	A	A	A	A	A		
0.11 ... 0.16	3RU11 16-0AB0	25	25	25	25	0.5	--	--	--	
0.14 ... 0.2	3RU11 16-0BB0	25	25	25	25	1	--	--	3RV13 21-0BC10	
0.18 ... 0.25	3RU11 16-0CB0	25	25	25	25	1	--	--	3RV13 21-0CC10	
0.22 ... 0.32	3RU11 16-0DB0	25	25	25	25	1.6	2	2	3RV13 21-0DC10	
0.28 ... 0.4	3RU11 16-0EB0	25	25	25	25	2	2	2	3RV13 21-0EC10	
0.35 ... 0.5	3RU11 16-0FB0	25	25	25	25	2	2	2	3RV13 21-0FC10	
0.45 ... 0.63	3RU11 16-0GB0	25	25	25	25	2	4	4	3RV13 21-0GC10	
0.55 ... 0.8	3RU11 16-0HB0	25	25	25	25	4	4	4	3RV13 21-0HC10	
0.7 ... 1	3RU11 16-0JB0	25	25	25	25	4	6	6	3RV13 21-0JC10	
0.9 ... 1.25	3RU11 16-0KB0	25	25	25	25	4	6	6	3RV13 21-0KC10	
1.1 ... 1.6	3RU11 16-1AB0	35	35	35	35	6	10	10	3RV13 21-1AC10	
1.4 ... 2	3RU11 16-1BB0	35	35	35	35	6	10	10	3RV13 21-1BC10	
1.8 ... 2.5	3RU11 16-1CB0	35	35	35	35	10	10	10	--	
2.2 ... 3.2	3RU11 16-1DB0	35	35	35	35	10	16	16	--	
2.8 ... 4	3RU11 16-1EB0	35	35	35	35	16	16	16	--	
3.5 ... 5	3RU11 16-1FB0	35	35	35	35	20	20	20	--	
4.5 ... 6.3	3RU11 16-1GB0	35	35	35	35	20	20	20	--	
5.5 ... 8	3RU11 16-1HB0	35	35	35	35	20	20	20	--	
7 ... 10	3RU11 16-1JB0	35	35	35	35	20	20	20	--	
9 ... 12	3RU11 16-1KB0	35	35	35	35	--	--	--	--	

Size S0		Fuses for type of coordination "1" ¹⁾ ToC 1				Fuses for type of coordination "2" ¹⁾ ToC 2				Motor starter protectors for type of coordination "2" ¹⁾ ToC 2
Setting range	3RU11 thermal overload relay	7.5 kW = 3RE1. 20-8XC25 (3RT10 25 contactor) $I_{e \max} = 17 \text{ A}$ (at 400 V, 50/60 Hz)		11 kW = 3RE1. 20-8XC26 (3RT10 26 contactor) $I_{e \max} = 25 \text{ A}$ (at 400 V, 50/60 Hz)		7.5 kW = 3RE1. 20-8XC25 (3RT10 25 contactor) $I_{e \max} = 17 \text{ A}$ (at 400 V, 50/60 Hz)		11 kW = 3RE1. 20-8XC26 (3RT10 26 contactor) $I_{e \max} = 25 \text{ A}$ (at 400 V, 50/60 Hz)		at $I_G = 50 \text{ kA/400 V, 50/60 Hz}$
		gL/gG		BS88		gL/gG		BS88		
A		A	A	A	A	A	A	A	A	
1.8 ... 2.5	3RU11 26-1CB0	63	63	63	63	10	10	10	10	3RV13 21-1CC10
2.2 ... 3.2	3RU11 26-1DB0	63	63	63	63	10	16	10	16	3RV13 21-1DC10
2.8 ... 4	3RU11 26-1EB0	63	63	63	63	16	16	16	16	3RV13 21-1EC10
3.5 ... 5	3RU11 26-1FB0	63	63	63	63	20	20	20	20	3RV13 21-1FC10
4.5 ... 6.3	3RU11 26-1GB0	63	63	63	63	20	25	20	25	3RV13 21-1GC10
5.5 ... 8	3RU11 26-1HB0	63	63	63	63	25	32	25	32	3RV13 21-1HC10
7 ... 10	3RU11 26-1JB0	63	63	63	63	25	32	32	35	3RV13 21-1JC10
9 ... 12.5	3RU11 26-1KB0	63	63	63	63	25	32	35	35	3RV13 21-1KC10
11 ... 16	3RU11 26-4AB0	63	63	63	63	25	32	35	35	3RV13 21-4AC10
14 ... 20	3RU11 26-4BB0	63	63	63	63	25	32	35	35	3RV13 21-4BC10
17 ... 22	3RU11 26-4CB0	--	--	100	100	--	--	35	35	3RV13 21-4CC10
20 ... 25	3RU11 26-4DB0	--	--	100	100	--	--	35	35	--

¹⁾ Coordination and short-circuit equipment according to EN 60947-4-1:
Type of coordination "1": In the short-circuit case, the contactor or starter must not put equipment or personnel at risk. They do not have to be suitable for further operation (without repair and the replacement of parts).
Type of coordination "2": In the short-circuit case, the contactor or starter must not put equipment or personnel at risk. They must be capable of further operation. There is a risk of contact welding.

For Operation in the Field, High Degree of Protection

3RE Encapsulated Starters

General data

Size S2		Fuses for type of coordination "1" ¹⁾ T_{0C} 1						Fuses for type of coordination "2" ¹⁾ T_{0C} 2						Motor starter protectors for type of coordination "2" ¹⁾ T_{0C} 2
Setting range	3RU11 thermal overload relay	15 kW = 3RT10 34 $I_{e \max} = 32 \text{ A}$ (at 400 V, 50/60 Hz)		18,5 kW = 3RT10 35 $I_{e \max} = 40 \text{ A}$ (at 400 V, 50/60 Hz)		22 kW = 3RT10 36 $I_{e \max} = 50 \text{ A}$ (at 400 V, 50/60 Hz)		15 kW = 3RT10 34 $I_{e \max} = 32 \text{ A}$ (at 400 V, 50/60 Hz)		18,5 kW = 3RT10 35 $I_{e \max} = 40 \text{ A}$ (at 400 V, 50/60 Hz)		22 kW = 3RT10 36 $I_{e \max} = 50 \text{ A}$ (at 400 V, 50/60 Hz)		at $I_{sc} = 50 \text{ kA}$ / 400 V, 50/60 Hz
		gL/gG A	BS88 A	gL/gG A	BS88 A	gL/gG A	BS88 A	gL/gG A	BS88 A	gL/gG A	BS88 A	gL/gG A	BS88 A	
5.5 ... 8	3RU11 36-1HB0	125	125	125	125	125	125	25	25	25	25	25	25	--
7 ... 10	3RU11 36-1JB0	125	125	125	125	125	125	32	32	32	32	32	32	--
9 ... 12.5	3RU11 36-1KB0	125	125	125	125	125	125	35	35	35	35	35	35	--
11 ... 16	3RU11 36-4AB0	125	125	125	125	125	125	40	40	40	40	40	40	--
14 ... 20	3RU11 36-4BB0	125	125	125	125	125	125	50	50	50	50	50	50	--
18 ... 25	3RU11 36-4DB0	125	125	125	125	125	125	63	63	63	63	63	63	3RV13 31-4DC10
22 ... 32	3RU11 36-4EB0	125	125	125	125	125	125	63	63	63	63	80	80	3RV13 31-4EC10
28 ... 40	3RU11 36-4FB0	125	125	125	125	125	125	63	63	63	63	80	80	3RV13 31-4FC10
36 ... 45	3RU11 36-4GB0	--	--	125	125	125	125	--	--	63	80	80	80	3RV13 31-4GC10
40 ... 50	3RU11 36-4HB0	--	--	--	--	160	160	--	--	--	--	80	80	3RV13 31-4HC10

¹⁾ Coordination and short-circuit equipment according to EN 60947-4-1:

Type of coordination "1": In the short-circuit case, the contactor or starter must not put equipment or personnel at risk. They do not have to be suitable for further operation (without repair and the replacement of parts).

Type of coordination "2": In the short-circuit case, the contactor or starter must not put equipment or personnel at risk. They must be capable of further operation. There is a risk of contact welding.

For Operation in the Field, High Degree of Protection 3RE Encapsulated Starters

Project planning aids

Dimensional drawings

Direct-on-line starter, size S00

3RE10 10
3RE19 13-1CB1
Metric cable gland M25

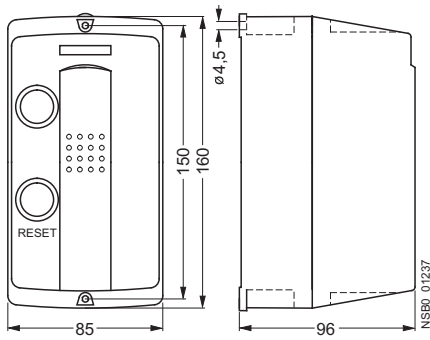

Direct-on-line starter, size S0

3RE10 20
3RE19 23-1CB2
Metric cable gland M25

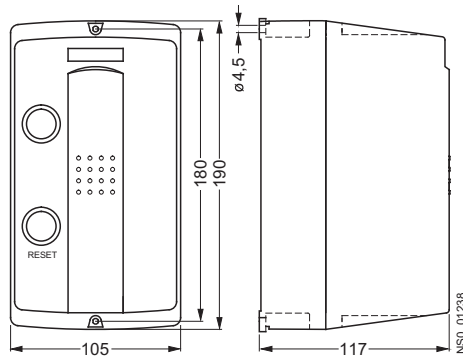

Direct-on-line starter, size S2

3RE19 33-1CB3

Reversing starter, size S00/S0

3RE13 10, 3RE19 23-2CB3
Metric cable gland M32

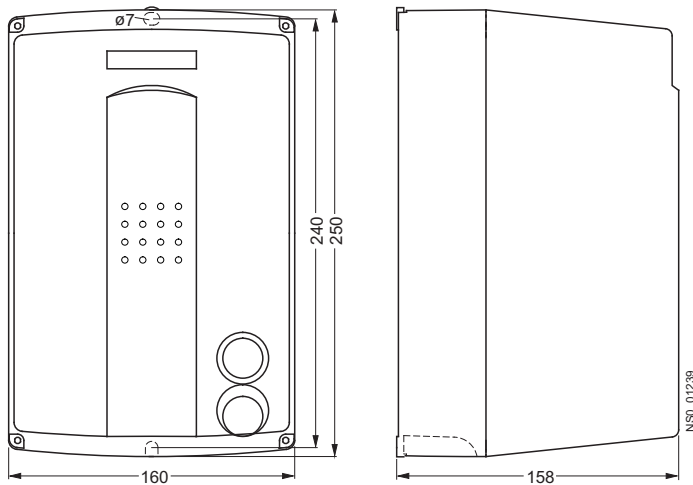

For Operation in the Field, High Degree of Protection

3RE Encapsulated Starters

Project planning aids

Schematics

Direct-on-line starter, size S00/S0

3RE10 10

3RE10 20

3RE19 13-1CB1 (see Accessories)

3RE19 23-1CB2 (see Accessories)

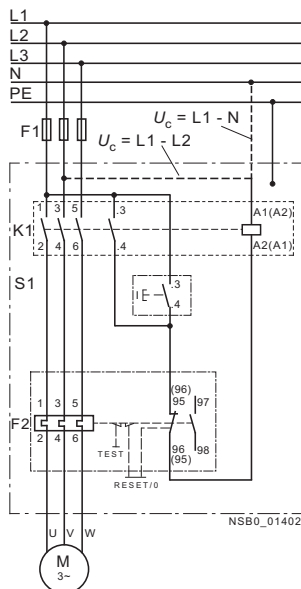

Direct-on-line starter, size S2

3RE19 33-1CB3 (see Accessories)

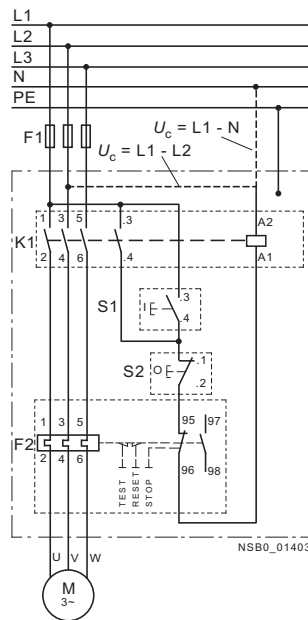

Reversing starter, size S00

3RE13 10

3RE19 13-2CB3 (see Accessories)

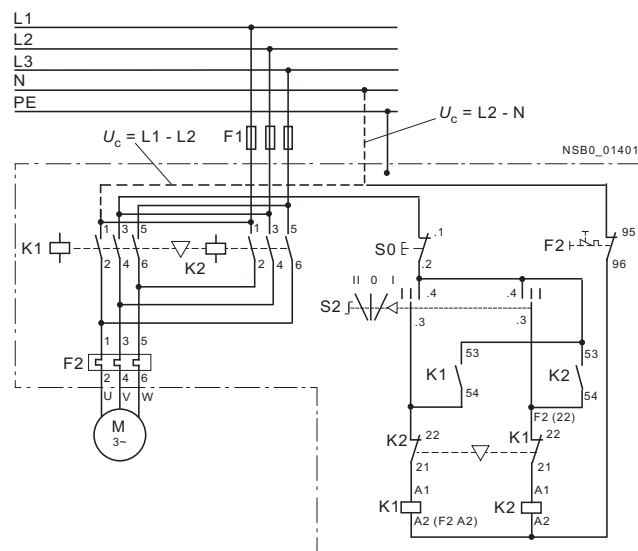

Reversing starter, size S0

3RE19 13-2CB3

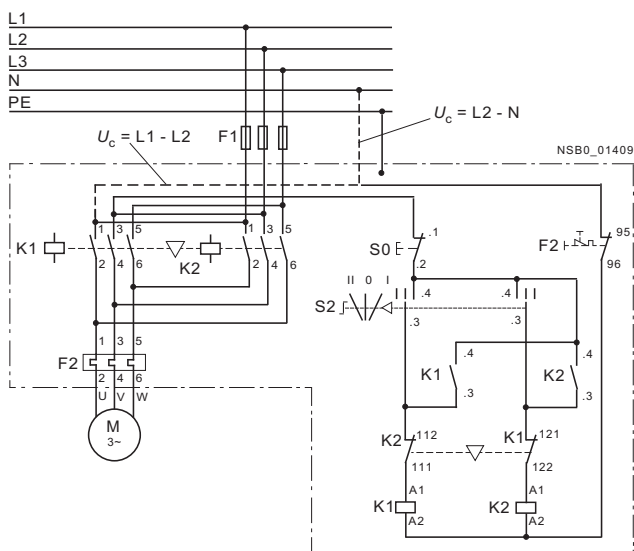

AS-Interface Motor Starters and Soft Starters

Motor Starters and Load Feeders, IP65/67

Motor starters, 24 V DC

Overview



Connection of an actuator roller with integrated DC motor to an AS-Interface 24 V DC motor starter

With the K60 AS-Interface 24 V DC motor starters for the low-end performance range up to 70 W, it is now possible to connect 24 V DC motors and the associated sensors directly to the AS-Interface quickly and easily.

Three different versions are available:

- Single direct-on-line starters (without brake and reversible quick-stop function)
- Double direct-on-line starters (with brake and reversible quick-stop function)
- Reversing starters (with brake and reversible quick-stop function)

DC motors are connected to the module using M12 plug-in connections. The sensors and the module electronics can be supplied from the yellow AS-Interface cable. An auxiliary voltage (24 V DC) is only required for supplying the outputs, which can be provided via the black AS-Interface cable.

Quick-stop function

All AS-Interface 24 V DC motor starters feature a quick-stop function which can be switched on and off as required using a switch integrated into the module. The quick-stop function allows a connected motor to be disconnected immediately using an applied sensor signal (High). The switch for the quick-stop function is located alongside the input sockets and is protected by an M12 sealing cap.

Brake

The double direct-on-line starter and the single reversing starter versions feature an integrated permanently set brake function, i. e. as soon as the output signal is set to "0", the motor is braked.

Start-up using integrated buttons

Buttons integrated into the module (below the output sockets) can be used to set the motor used. The buttons are protected by an M12 sealing cap.

Note:

Concerning double and reversing starters: *If an input with the quick-stop function receives a "High" signal, the corresponding output (e. g. quick-stop input 1 → output 1) is switched off within the device (the motor is braked). The manual key function (Key 1/2) for local operation is only permitted to be used during "CPU Stop" in the higher-level PLC.*

Note:

Concerning single direct-on-line starters: *If an input with the quick-stop function receives a "High" signal, the corresponding output (e. g. quick-stop input 1 → output 1) is switched off within the device (the motor runs down without being braked). The manual key function (Key 1) for local operation is only permitted to be used during "CPU Stop" in the higher-level PLC.*

AS-Interface Motor Starters and Soft Starters

Motor Starters and Load Feeders, IP65/67

Motor starters, 24 V DC

Applications

Single direct starter without brake

(with adjustable quick-stop function)

1st possibility: Connection to a maximum of four sensors without pollution indication

2nd possibility: Connection to a maximum of two sensors with pollution indication

Double direct starter with brake

(with adjustable quick-stop function)

1st possibility: Connection to a maximum of four sensors without pollution indication

2nd possibility: Connection to a maximum of two sensors with pollution indication

Single reversing starter with brake

(with adjustable quick-stop function)

1st possibility: Connection to a maximum of four sensors without pollution indication

2nd possibility: Connection to a maximum of two sensors with pollution indication

NSA0_00348a

AS-Interface Motor Starters and Soft Starters

Motor Starters and Load Feeders, IP65/67

Motor starters, 24 V DC

Technical specifications

		Single direct-on-line starters 4 inputs 1 output Quick-stop function 3RK1 400-1NQ01-0AA4	Double direct-on-line starters 4 inputs 2 outputs Quick-stop function 3RK1 400-1MQ01-0AA4	Single reversing starters 4 inputs 1 output Quick-stop function 3RK1 400-1MQ03-0AA4
Slave type		Standard slave		
Operational voltage acc. to AS-Interface specification	V	26.5 ... 31.5		
Total current input from AS-Interface	mA	≤ 270		
Input circuit		PNP		
Inputs		Short-circuit and overload resistant		
• Sensor supply using AS-Interface		3-wire		
• Sensors		20 ... 30		
• Voltage range	V	200 ($T_u \leq 40 \text{ °C}$)/150 ($T_u \leq 55 \text{ °C}$)		
• Current carrying capacity for sensor supply	mA	≥ 10		
• Switching level High	V	≤ 5		
• Switching level Low	V	1 = Sensor supply L+ 2 = Data input 3 = Sensor supply L- 4 = Data input/quick-stop function 5 = Ground terminal		
• Socket assignment		Using black AS-Interface flat cable		
• External power supply 24 V DC		80		
• Max. starting ramp time for DC motors	ms	4.5		
• Max. motor starting current (limited in the module)	A			
Outputs		Solid-state		
• Type of output		3 ($T_u \leq 55 \text{ °C}$)		
• Rated current carrying capacity per output typical	A		1 x 3 ($T_u \leq 55 \text{ °C}$) 2 x 2 ($T_u \leq 55 \text{ °C}$)	2.5 ($T_u \leq 55 \text{ °C}$)
• Maximum summation current per module	A		4	--
• Voltage drop (without feeder cable)	V		0,6	1,2
• Short-circuit protection		Built-in		
• Induction protection		Built-in		
• Watchdog		Built-in		
I/O configuration	Hex	7		
ID code	Hex	F		
Assignment of data bits		PIN 4 = IN1 (D0/quick-stop1) PIN 2 = IN2 (D1)		
• Socket 1		PIN 4 = IN3(D2) PIN 2 = IN4(D3)		
• Socket 2		PIN 4 = IN3 (D2/quick-stop2) PIN 2 = IN4 (D3)		
• Socket 3		PIN 4 = OUT1 (D0)		PIN 2,4 = OUT1 (D0, D1)
• Socket 4		--		--
AS-Interface certificate		Yes		
Approvals		UL, CSA		
Degree of protection		IP67		
Ground terminal		Yes		
Ambient temperature	°C	-25 ... +55		
Storage temperature	°C	-40 ... +85		
Number of I/O sockets		3	4	3
Note		Max. switching frequency when activating e. g. a 10 W DC motor ($U_{aux} = 28,8 \text{ V}$ /duty cycle = 50 %):		
		• $T_{u_{max}}$ /°C: 55		• Max. switching frequency/h: 1000
		• Max. switching frequency/h: 1500		

AS-Interface Motor Starters and Soft Starters

Motor Starters and Load Feeders, IP65/67

Motor starters, 24 V DC

Dimensional drawings

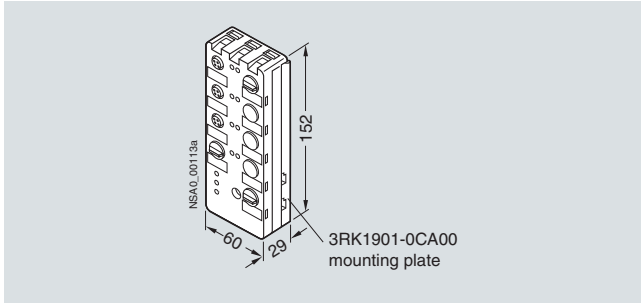

3RK1 400-1NQ01-0AA4

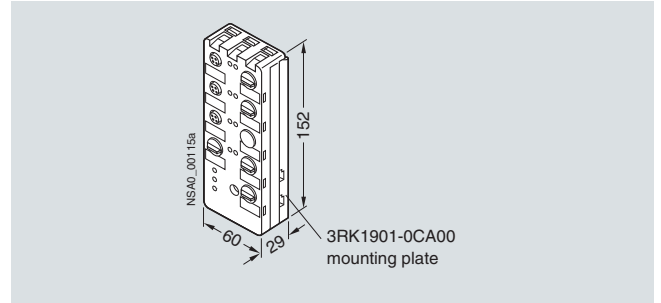

3RK1 400-1MQ03-0AA4

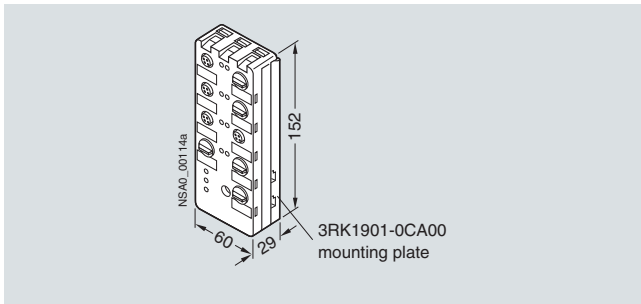

3RK1 400-1MQ01-0AA4

Monitoring and Control Devices

7

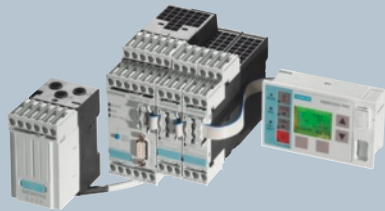

7/2	Introduction
7/6	SIMOCODE 3UF Motor Management and Control Devices SIMOCODE pro 3UF7 motor management and control devices
7/32	3UF18 current transformers for overload protection
	LOGO! Logic Modules
7/37	General data
7/38	LOGO! Modular basic versions
7/39	LOGO! Modular pure versions
ST 70 ¹⁾	LOGO! Modular expansion modules
ST 70 ¹⁾	LOGO! Modular communication modules
ST 70 ¹⁾	AS-Interface connection for LOGO!
ST 70 ¹⁾	LOGO! Contact
7/40	LOGO! Software
	3RP, 3RT19 Timing Relays
7/41	General data
7/46	3RP15 timing relays in industrial enclosure, 22.5 mm
7/52	3RP20 timing relays, 45 mm
7/55	3RT19 16, 3RT19 26 timing relays for mounting onto contactors
	Monitoring Relays
	<u>3UG Monitoring Relays for Electrical and Additional Measurements</u>
7/59	Line monitoring
7/65	Voltage monitoring
7/69	Current monitoring
7/73	Power factor and active current monitoring
	Residual current monitoring:
7/78	- Residual current monitoring relays
7/83	- 3UL22 summation current transformers
	Insulation monitoring:
7/84	- For ungrounded AC networks
7/86	- For ungrounded DC networks
	Level monitoring:
7/88	- Level monitoring relays
7/92	- Level monitoring sensors
7/93	Speed monitoring
	<u>3RS10, 3RS11 Temperature Monitoring Relays</u>
7/97	General data
7/100	Relays, analogically adjustable, for 1 sensor
7/104	Relays, digitally adjustable, for 1 sensor
7/107	Relays, digitally adjustable, for up to 3 sensors
	<u>3RN1 Thermistor Motor Protection</u>
7/110	For PTC sensors

3TK28 Safety Relays

7/116	General data
7/118	With electronic enabling circuits
7/127	With relay enabling circuits
7/138	With contactor relay enabling circuits
7/143	With special functions

3RK3 Modular Safety Systems

7/147	General data
7/148	Modules

Interface Converters

7/155	3RS17 interface converters
-------	----------------------------

¹⁾ See Catalog ST 70 · 2009 "Products for Totally Integrated Automation and Micro Automation".

Monitoring and Control Devices

Introduction

Overview

The advantages at a glance



3UF7



6ED1 052



3RP15

		Type	Page
SIMOCODE 3UF motor management and control devices			
SIMOCODE pro 3UF7	<ul style="list-style-type: none"> • Compact, modular design • Unique flexibility in terms of functionality and hardware configuration • Wide functional range from the distributed I/O system to the autonomous motor management system • All control functions from the direct-on-line starter to the pole-changing switch with reversing contactor • All motor sizes • Integration in all PROFIBUS-capable automation systems • Application in low-voltage controlgear for motor control centers in the process industry • Increases plant availability • Saves costs during construction, commissioning and operation of the plant • Extensive data of the motor feeder available everywhere on the PROFIBUS • All protection, monitoring and control functions for the motor feeder in a single system 	3UF7	7/6
3UF18 current transformers for overload protection	<ul style="list-style-type: none"> • Protection transformer for activating overload relays or for use with SIMOCODE 3UF • Ensures proportional current transfer up to a multiple of the primary rated current 	3UF18	7/32
LOGO! logic modules			
LOGO! logic modules	<ul style="list-style-type: none"> • Compact, user-friendly and low-cost solution for simple control tasks • Universal: <ul style="list-style-type: none"> - Building installation and wiring (lighting, shutters, awnings, doors, access control, barriers, ventilation systems ...) - Control cabinet installation - Machine and device construction (pumps, small presses, compressors, hydraulic lifts, conveyors ...) - Special controls for conservatories and greenhouses - Signal preprocessing for other controllers • Flexible expansion depending on the application 		
LOGO! Modular basic versions	<ul style="list-style-type: none"> • With display, pushbuttons and an interface for connecting expansion units 	6ED1 052-1	7/38
LOGO! Modular pure versions	<ul style="list-style-type: none"> • Without display and pushbuttons but with an interface for connecting expansion units 	6ED1 052-2	7/39
LOGO! Modular expansion modules	<ul style="list-style-type: none"> • For connection to LOGO! Modular basic versions with digital inputs and outputs or analog inputs and outputs 	6ED1 055-1	ST 70 ¹⁾
LOGO! Modular communication modules	<ul style="list-style-type: none"> • For integrating LOGO! in an <i>instabus</i> KNX <i>EIB</i> system or as an AS-Interface slave 	6BK1 700, 3RK1 400	ST 70 ¹⁾
LOGO! Power	<ul style="list-style-type: none"> • Power supply for converting the mains voltage of 100 ... 240 V AC into an operational voltage of 24 V DC or 12 V DC 	6EP1 3	ST 70 ¹⁾
LOGO! Contact	<ul style="list-style-type: none"> • Switching module for switching resistive loads and motors directly 	6ED1 057-4	ST 70 ¹⁾
LOGO! Software	<ul style="list-style-type: none"> • For switchgear program generation on the PC 	6ED1 058	7/40
3RP, 3RT19 timing relays			
3RP15 timing relays in industrial enclosure, 22.5 mm	<ul style="list-style-type: none"> • Low-cost solution with monofunctions such as response delay, off-delay, clock-pulse, wye-delta function and multi-function • Wide voltage range versions 	3RP15	7/46
3RP20 timing relays, 45 mm	<ul style="list-style-type: none"> • The solution for small mounting depths • The low mounting height reduces the tier spacing 	3RP20	7/52
3RT19 16, 3RT19 26 timing relays for mounting onto contactors	<ul style="list-style-type: none"> • Saves space because the relay is mounted onto the contactor • Wiring advantages thanks to direct contacting to the contactor 	3RT19 16, 3RT19 26	7/55

¹⁾ See Catalog ST 70 · 2009 "Products for Totally Integrated Automation and Micro Automation".

The advantages at a glance



3UG45 11



3UG46 16



3UG46 33

3UG monitoring relays for electrical and additional measurements		Type	Page
<i>Line monitoring</i>			
Phase sequence	• Low-cost solution for monitoring the phase sequence	3UG45 11	7/59
Phase sequence, phase failure, phase unbalance	• Wide voltage range from 160 ... 690 V	3UG45 12	7/59
Phase sequence, phase failure, phase unbalance and undervoltage	• Analogically adjustable	3UG45 13	7/60
	• Wide voltage range from 160 ... 690 V		
Phase sequence, phase failure, phase unbalance over limit values, overvoltage and undervoltage	• Digitally adjustable with LCD for indication of ACTUAL value and device status	3UG46 14	7/60
	• Wide voltage range from 160 ... 690 V		
Phase sequence, phase and N conductor failure, phase unbalance over limit values, overvoltage and undervoltage	• Digitally adjustable with LCD for indication of ACTUAL value and device status	3UG46 15	7/61
	• Wide voltage range from 160 ... 690 V	3UG46 16	7/61
Automatic correction of the direction of rotation in case of wrong phase sequence, phase failure, phase unbalance, overvoltage and undervoltage		3UG46 17	7/61
Automatic correction of the direction of rotation in case of wrong phase sequence, phase and N conductor failure, phase unbalance, overvoltage and undervoltage		3UG46 18	7/61
<i>Voltage monitoring</i>			
Voltage monitoring with internal power supply for overvoltage and undervoltage	• Digitally adjustable with LCD for indication of ACTUAL value and device status	3UG46 33	7/65
Voltage monitoring with auxiliary voltage for overvoltage and undervoltage	• Wide measuring ranges	3UG46 31,	7/66
	• Version for wide voltage range	3UG46 32	
<i>Current monitoring</i>			
Current monitoring with auxiliary voltage for overshoot and undershoot	• Digitally adjustable with LCD for indication of ACTUAL value and device status	3UG46 21,	7/69
	• Wide measuring ranges	3UG46 22	
	• Version for wide voltage range		
<i>Power factor and active current monitoring (motor load monitoring)</i>			
Power factor and active current monitoring with internal power supply for overshoot, undershoot or window monitoring	• For load monitoring over the entire torque range	3UG46 41	7/73
	• Digitally adjustable with LCD for indication of ACTUAL value and device status		
	• Wide voltage range from 90 ... 690 V		
<i>Residual current monitoring</i>			
Residual current monitoring relays	• Digitally adjustable with LCD for indication of ACTUAL value and device status	3UG46 24	7/78
	• Adjustable threshold values for warning and disconnection		
	• For plant monitoring		
	• Wide voltage range from 90 ... 690 V		
Summation current transformers	• Detects fault currents in machines and plants	3UL22	7/83
<i>Insulation monitoring</i>			
Monitoring of the insulation resistance for ungrounded AC or DC networks from 1 to 110 kΩ	• Test button	3UG30 81,	7/84
	• With or without memory	3UG30 82	
	• Switchable measuring range		
<i>Level monitoring</i>			
Fill level and resistance	• As single-step or two-step controls for inlet or outlet monitoring of conducting liquids or as resistance threshold switch	3UG45 01	7/88
	• Adjustable, wide range from 2 ... 200 kΩ		
	• UNDER/OVER adjustable		
Level monitoring sensors	• Wire, rod or bow electrodes	3UG32	7/92
<i>Speed monitoring</i>			
Speed monitoring for overshoot, undershoot or window monitoring	• Digitally adjustable with LCD for indication of ACTUAL value and device status	3UG46 51	7/93
	• Wide measuring ranges		
	• Version for wide voltage range		
	• Together with a sensor for monitoring continuous pulses		
	• With or without memory		
	• Adjustable delay times		

Monitoring and Control Devices

Introduction

The advantages at a glance



3RS10



3RN1



3TK28

		Type	Page
3RS10, 3RS11 temperature monitoring relays			
<i>For monitoring the temperatures of solids, liquids, and gases</i>			
Relays, analog adjustable, for 1 sensor	<ul style="list-style-type: none"> • Separate versions for overshoot and undershoot • For simple monitoring tasks • For PT100 or thermoelements J and K • Variable hysteresis 	3RS10, 3RS11	7/100
Relays, digitally adjustable, for 1 sensor	<ul style="list-style-type: none"> • For two-step or three-step controls • For monitoring heat generation plants • For PT100/1000, KTY83/84, NTC or thermoelements type J, K, T, E, N, R, S, B 	3RS10, 3RS11, 3RS20, 3RS21	7/104
Relays, digitally adjustable for up to 3 sensors	<ul style="list-style-type: none"> • For simultaneously monitoring several sensors • Especially suited for monitoring motor winding temperatures • For PT100/1000, KTY83/84, NTC 	3RS10	7/107
3RN1 thermistor motor protection			
For PTC sensors	<ul style="list-style-type: none"> • Relays for monitoring motor winding temperatures with type A PTC sensors • Integrated with ATEX approval • Closed-circuit principle • Depending on the version: with short-circuit and open-circuit detection, protection against voltage failure, manual/auto/remote RESET, 1 CO, 1 NO + 1 NC, 2 CO, 1 NO + 1 CO or 2 CO hard gold-plating 	3RN1	7/110
3TK28 safety relays			
With electronic enabling circuits	<ul style="list-style-type: none"> • Permanent function checking • No wear because switched electronically • High switching frequency • Long electrical endurance • Evaluation of solid-state sensors • Sensor lead up to max. 2000 m • Cascading possible • Insensitive to vibrations and dirt • Compact design, low weight • Approved for the world market 	3TK28 4	7/118
With relay enabling circuits	<ul style="list-style-type: none"> • Compact design • Floating safe outputs • Also suitable for press and punch controls • Can be used up to an ambient temperature of max. 70 °C 	3TK28 2, 3TK28 3	7/127
With contactor relay enabling circuits	<ul style="list-style-type: none"> • Enabling circuits, floating • AC-15/DC-13 switching capacity • Protective separation • Long mechanical and electrical endurance • Certified as a complete unit • Fault minimization and cost reduction through factory wiring • Low installation costs 	3TK28 5	7/138
With special functions	<ul style="list-style-type: none"> • Floating safe outputs • Signaling outputs for status and diagnostic signals • Safe standstill monitoring 	3TK28 1	7/143

The advantages at a glance



3RK3



3RS17

Type	Page
------	------

3RK3 modular safety system**Freely configurable, modular safety relays**

- More functionality and flexibility through freely configurable safety logic
- For all safety applications thanks to compliance with the highest safety requirements (Category 4 according to EN 954-1, Performance Level e according to ISO 13849-1 or SIL3 according to IEC 62061)
- Can be used globally
- Modular hardware configuration
- Parameterization by means of software instead of wiring
- Removable terminals for greater plant availability

3RK3

7/147

3RS17 interface converters**Converters for standard signals and non-standard variables**

- All terminals protected against polarity reversing and overvoltage up to 30 V
- For electrical separation and conversion of analog signals
- Short-circuit resistant outputs
- From 6.2 mm width
- Switchable multi-range converters
- Versions with manual/automatic switch for setpoint selection
- Versions for conversion of analog variables into frequency

3RS17

7/155

Options

On the following pages you will find selection tables for monitoring and control devices.



Screw terminals



Spring-type terminals

These connections are indicated in the Technical specifications by orange backgrounds.

"Increased safety" type of protection EEx e/d according to ATEX directive 94/9/EC

The communication-capable, modularly designed SIMOCODE pro motor management system (SIRIUS Motor Management and Control Devices) protects motors of types of protection EEx e and EEx d in potentially explosive areas.

ATEX approval for operation in areas subject to explosion hazard

The SIRIUS 3RN1 thermistor motor protection relay for PTC sensors is certified according to ATEX Ex II (2) G and GD for gases and dust.

The SIRIUS SIMOCODE pro 3UF7 motor management system is certified for the protection of motors in areas subject to explosion hazard according to

- ATEX Ex I (M2); equipment group I, category M2 (mining)
- ATEX Ex II (2) GD; equipment group II, category 2 in area GD

See "Appendix" --> "Standards and approvals" --> "Type overview of approved devices for potentially explosive areas (ATEX explosion protection)".

SIMOCODE 3UF Motor Management and Control Devices

SIMOCODE pro 3UF7 motor management and control devices

Overview

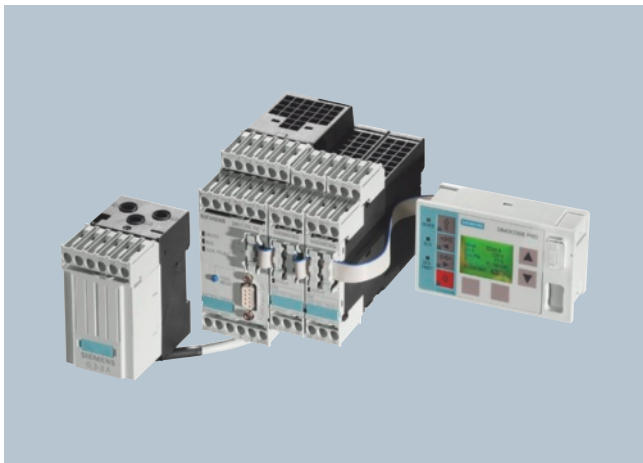

SIMOCODE pro V with current/voltage measuring module, expansion modules and operator panel with display

SIMOCODE pro is a flexible, modular motor management system for motors with constant speeds in the low-voltage performance range. It optimizes the connection between I&C and motor feeder, increases plant availability and allows significant savings to be made for startup, operation and maintenance of a system.

When SIMOCODE pro is installed in the low-voltage switchboard, it is the intelligent interface between the higher-level automation system and the motor feeder and includes the following:

- Multifunctional, solid-state full motor protection which is independent of the automation system
- Integrated control functions instead of hardware for the motor control
- Detailed operating, service and diagnostics data
- Open communication through PROFIBUS DP, the standard for fieldbus systems

SIMOCODE ES is the software package for SIMOCODEpro parameterization, start-up and diagnostics.

Design

General

SIMOCODE pro is a modularly constructed motor management system which is subdivided into two device series with different functional scopes:

- SIMOCODE pro C and
- SIMOCODE pro V.

Both series (systems) are made up of different hardware components (modules):

System	SIMOCODE pro C	SIMOCODE pro V
Modules	<ul style="list-style-type: none"> • Basic unit 1 • Current measuring module • Operator panel (optional) 	<ul style="list-style-type: none"> • Basic unit 2 • Current measuring module or current/voltage measuring module • Decoupling module (optional) • Operator panel or operator panel with display (optional) • Expansion modules (optional)

Per feeder each system always comprises one basic unit and one separate current measuring module. The two modules are connected together electrically through the system interface with a connection cable and can be mounted mechanically connected as a unit (one behind the other) or separately (side by side). The motor current to be monitored is decisive only for the choice of the current measuring module.

An operator panel for mounting in the control cabinet door is optionally connectable through a second system interface on the basic unit. Both the current measuring module and the operator panel are electrically supplied by the basic unit through the connection cable. More inputs, outputs and functions can be added to basic unit 2 (SIMOCODE pro V) by means of optional expansion modules, thus supplementing the inputs and outputs already existing on the basic unit.

All modules are connected by connection cables. The connection cables are available in various lengths. The maximum distance between the modules (e.g. between the basic unit and the current measuring module) must not exceed 2.5 m. The total length of all the connection cables in a single system must not be more than 3 m.

SIMOCODE pro designed for mixed operation

Depending on functional requirements, the two systems can be used simultaneously without any problems and without any additional outlay in a low-voltage system. SIMOCODE pro C is fully upward-compatible to SIMOCODE pro V. The same components are used. The parameterization of SIMOCODE pro C can be transferred without any problems. Both systems have the same removable terminals and the same terminal designations.

SIMOCODE 3UF Motor Management and Control Devices

SIMOCODE pro 3UF7 motor management and control devices

SIMOCODE pro C, basic unit 1

The compact system for

- Direct-on-line and reversing starters
- For actuation of a circuit breaker (MCCB) with up to 4 binary inputs, up to 3 monostable relay outputs and one thermistor connection (binary PTC)

The basic unit 1 is available in two different versions for the following supply voltages:

- 24 V DC
- 110 ... 240 V AC/DC



SIMOCODE pro C, basic unit 1

Inputs:

4 binary inputs, with internal supply from 24 V DC

Outputs:

3 (2+1) monostable relay outputs

Thermistor connection for binary PTC

PROFIBUS interface:

- 9-pole SUB-D or
- Terminal connection

Connection of the supply voltage:

- 24 V DC or
- 110 ... 240 V AC/DC

Test/reset button

3 LEDs

2 system interfaces for connection of

- a current measuring module and
- an operator panel

Basic unit 1 is suitable for standard rail mounting or, with additional push-in lugs, for fixing to a mounting plate.

SIMOCODE pro V, basic unit 2

The variable system which offers all SIMOCODE pro C functions plus many additional functions. Basic unit 2 supports the following control functions:

- Direct-on-line and reversing starters
- Wye/delta starters, also with direction reversal
- Two speeds, motors with separate windings (pole-changing switch); also with direction reversal
- Two speeds, motors with separate Dahlander windings (also with direction reversal)
- Positioner actuation
- Solenoid valve actuation
- Actuation of a motor starter protector or circuit breaker (MCCB)
- Soft starter actuation (also with direction reversal)

Basic unit 2 has 4 binary inputs, 3 monostable relay outputs and one thermistor connection (binary PTC). The type and number of inputs and outputs can be increased by means of additional expansion modules.

Basic unit 2 is available in two different versions for the following supply voltages:

- 24 V DC
- 110 ... 240 V AC/DC



SIMOCODE pro V, basic unit 2

Inputs:

4 binary inputs, with internal supply from 24 V DC

Outputs:

3 (2+1) monostable relay outputs

Thermistor connection for binary PTC

PROFIBUS interface:

- 9-pole SUB-D or
- Terminal connection

Connection of the supply voltage:

- 24 V DC or
- 110 ... 240 V AC/DC

Test/reset button

3 LEDs

2 system interfaces for connection of

- a current measuring module or current/voltage measuring module,
- expansion modules and
- an operator panel.

Basic unit 2 is suitable for standard rail mounting or, with additional push-in lugs, for fixing to a mounting plate.

SIMOCODE 3UF Motor Management and Control Devices

SIMOCODE pro 3UF7 motor management and control devices

Current measuring modules (current ranges)

The current measuring module is selected for each feeder according to the rated motor current to be monitored. Available for this purpose are various current measuring modules for current ranges from 0.3 ... 630 A. The current measuring module is connected to the basic unit by a connection cable and is supplied with electricity by the basic unit through this connection cable. Current measuring modules up to 100 A are suitable for standard rail mounting or can be fixed directly to the mounting plate by means of additional push-in lugs. Similarly, current measuring modules up to 200 A can also be mounted on standard mounting rails or be fixed directly to mounting plates by means of fixtures integrated in the enclosure. Finally, current measuring modules up to 630 A can only be mounted with the integrated screw fixtures.

Note:

Current measuring modules for up to 100 A current setting can be mechanically connected to the corresponding basic unit and mounted with it as a unit (one behind the other). For larger current measuring modules, only separate mounting is possible.

Current measuring modules for the following current ranges are offered:

- 0.3 ... 3 A with straight-through current transformer
- 2.4 ... 25 A with straight-through current transformer
- 10 ... 100 A with straight-through current transformer
- 20 ... 200 A with straight-through current transformer or busbar connection
- 63 ... 630 A with busbar connection









For motor currents up to 820 A, a current measuring module for 0.3 ... 3 A, for example, can be used in combination with a 3UF1 8 interposing/current transformer.

Current/voltage measuring modules (voltage range)

Current/voltage measuring modules have the same functions as the current measuring modules. However, they can only be used in combination with basic unit 2. They offer the same current ranges for the rated motor current. Mounting on standard mounting rails, on mounting plates or directly on the contactor is also the same as with the current measuring modules. They can also measure voltages up to 690 V in the main circuit, which is necessary for calculating or monitoring power-related measured variables. Current/voltage measuring modules have additional removable terminals, to which the voltages of all three phases of the main circuit are connected (3-pole). An additional 3-core cable can be used, for example, to directly connect the main circuit from the busbar terminals of the current/voltage measuring modules to the voltage measuring terminals.

Note:

Current/voltage measuring modules can only be mounted separately from the associated basic unit 2. If the current/voltage measuring module is used in non-grounded networks or in networks with insulation measurement or monitoring, then a decoupling module must be used in addition.

Width				
45 mm	55 mm	120 mm	145 mm	
				Current measuring modules
				Current/voltage measuring modules
Current setting				To measure and monitor motor currents up to 820 A, matching 3UF18 intermediate current transformers are available for the current measuring modules and current/voltage measuring modules.
0.3 ... 3 A; 2.4 ... 25 A	10 ... 100 A	20 ... 200 A	63 ... 630 A	
Straight-through transformers		Busbar connection		

Sizes and current setting of the current measuring modules and the current/voltage measuring modules

SIMOCODE 3UF Motor Management and Control Devices

SIMOCODE pro 3UF7 motor management and control devices

Decoupling module for current/voltage measuring modules



Decoupling module

If the voltage and power measuring module from SIMOCODE pro is used in non-grounded networks, then a decoupling module must be installed on the system interface upstream from each current/voltage measuring module. If the voltage and power measuring module from SIMOCODE pro is used in networks with additional insulation measurement or insulation monitoring, then a decoupling module must be installed likewise upstream from each current/voltage measuring module. If 3UF7 10 current-only measuring modules are used in these networks, then additional decoupling modules must not be used under any circumstances.

Note:

When a decoupling module is used, restrictions on the number of connectable expansion modules must be observed (see page 7/13).

Operator panels

The operator panel is used to control the motor feeder and can replace all conventional pushbuttons and indicator lights to save space. This means that SIMOCODE pro or the feeder can be operated directly at the control cabinet and that the system interface is connected externally for easier parameterization or diagnostics using a PC or programming device, for example.

The operator panel is connected to the basic unit over a connection cable from its rear system interface and is supplied electrically from the basic unit.

The operator panel has 5 freely assignable buttons and a total of 10 LEDs, of which 7 LEDs can be used as required and assigned to any status signal.

A PC or programming device can be connected to the front system interface over the PC cable.

The operator panel is mounted in the control cabinet door or the front plate of, for example, a withdrawable unit and satisfies degree of protection IP54 with the system interface covered.

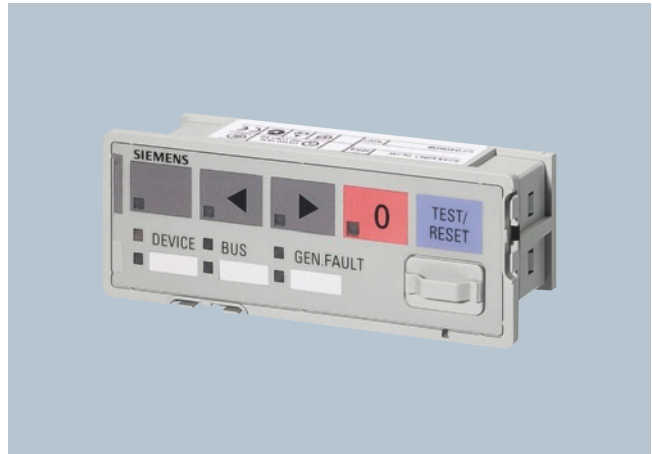

Operator panel for SIMOCODE pro

- 10 LEDs
- Test/reset button
- 4 control keys
- 2 system interfaces on the front with interface covers

SIMOCODE 3UF Motor Management and Control Devices

SIMOCODE pro 3UF7 motor management and control devices

Operator panels with display

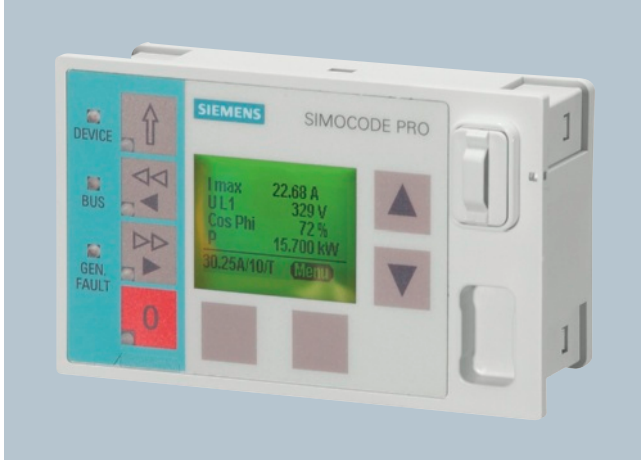

Operator panel with display for SIMOCODE pro V

As an alternative to the 3UF7 20 standard operator panel for SIMOCODE pro V there is also an operator panel with display: the 3UF7 21 is thus able in addition to indicate current measured values, operational and diagnostics data or status information of the motor feeder at the control cabinet. This operator panel can be used solely with basic unit 2 (SIMOCODE pro V), product version E03 and higher. It includes all the status LEDs also found on the basic unit and provides access to the system interface outside the control cabinet. The pushbuttons of the operator panel can be used to control the motor while at the same time the display indicates measured actual values, status information, fault messages or the device-internal fault protocol.

Overview of features:

- 7 LEDs, 4 of them user-assignable (4 green LEDs are integrated in the motor control pushbuttons, preferably for the feedback of switching states, e. g. On, Off, Left, Right, etc.)
- 4 user-assignable buttons for controlling the motor feeder
- 4 buttons for navigating in the display menu, 2 of them as softkeys with function options (e. g. Test/Reset)
- 2 system interfaces on the front with interface covers

Using the display settings each user can select for himself how the measured values are presented as standard and how the displayed unit is converted (e. g. °C -> °F). The menu language is also switchable. Following options are available:

- English
- Finnish
- French
- German
- Italian
- Polish
- Portuguese
- Spanish

Note:

The operator panel with display can be used solely with basic unit 2, product version E03 and higher. Furthermore, if the operator panel with display is used, restrictions on the number of connectable expansion modules must be observed (see page 7/13).

Inscription software for pushbuttons and LEDs on the operator panels

All operator panels come with prefabricated labeling strips. Using the latest version of the labeling software "SIRIUS Label Designer" it is also possible to produce user-specific inscription for the keys and LEDs of the operator panels from SIMOCODE pro.

Note:

The multilingual software is available free of charge from <http://www.siemens.com/simocode>

Three different types of prepunched labeling strips are available for printing and can be ordered as an accessory part. With the help of a laser printer it is then easy to label the keys or LEDs of the 3UF7 20 operator panel or the keys of the 3UF7 21 operator panel with display.

Expansion modules for additional I/Os and functions

With basic unit 2 (SIMOCODE pro V), it is possible to expand the number and type of inputs and outputs in order to implement additional functions, for example. Each expansion module has two system interfaces on the front. Through the one system interface the expansion module is connected to the system interface of basic unit 2 using a connection cable, for example; through the second system interface, further expansion modules or the operator panel can be connected. The power supply for the expansion modules is provided by the connection cable through basic unit 2.

All expansion modules are suitable for standard rail mounting or can be directly fixed to a mounting plate using additional push-in lugs. Basic unit 2 can be extended on the whole with up to 5 expansion modules.

SIMOCODE 3UF Motor Management and Control Devices

SIMOCODE pro 3UF7 motor management and control devices

Expansion with additional binary I/Os through digital modules

Up to two digital modules can be used to add additional binary inputs and relay outputs to basic unit 2. The input circuits of the digital modules are supplied from an external power supply. The following versions are available:

- 4 inputs, supplied externally with 24 V DC and 2 monostable relay outputs
- 4 inputs, supplied externally with 110 ... 240 V AC/DC and 2 monostable relay outputs
- 4 inputs, supplied externally with 24 V DC and 2 bistable relay outputs
- 4 inputs, supplied externally with 110 ... 240 V AC/DC and 2 bistable relay outputs

Up to two digital modules can be connected to one basic unit 2. All versions can be combined with each other.



3UF7 300-1AB00-0 (left) and 3UF7 300-1AU00-0 (right) digital modules

4 binary inputs, externally supplied with

- 24 V DC or
- 110 ... 240 V AC/DC

2 relay outputs

- Monostable or
- Bistable (the switching state of the relay outputs is also maintained following failure of the supply voltage on basic unit 2)

1 Ready LED

2 system interfaces for connection

- to basic unit 2,
- of expansion modules,
- of a current measuring module or current/voltage measuring module,
- of an operator panel.

Note:

For the implementation of some motor control functions, in addition to the relay outputs on basic unit 2, at least one further digital module is required.

Expansion with a ground-fault monitoring module with an external summation current transformer

Instead of ground-fault monitoring using the current measuring modules or current/voltage measuring modules, it may be necessary, especially in high-impedance grounded networks, to implement ground-fault monitoring for smaller ground fault currents using a summation current transformer. A ground-fault module can be used to add an additional input to basic unit 2 for connection of a summation current transformer (3UL2 20.-.A).

Maximum one ground-fault module can be connected to one basic unit 2.



3UF7 500-1AA00-0 ground-fault module

1 input for connecting a summation current transformer (3UL2 20.-.A)

1 Ready LED

2 system interfaces for connection

- to basic unit 2,
- of expansion modules,
- of a current measuring module or current/voltage measuring module,
- of an operator panel.

Note:

For the corresponding summation current transformers for rated fault currents of 0.3 A, 0.5 A or 1 A see page 7/83.

SIMOCODE 3UF Motor Management and Control Devices

SIMOCODE pro 3UF7 motor management and control devices

Expansion of analog temperature monitoring with a temperature module

Independently of the thermistor motor protection of the basic units, up to 3 analog temperature sensors can be evaluated using a temperature module.

The temperatures measured here can be completely integrated in the process, monitored and supplied to a higher-level automation system through PROFIBUS. The temperature module can be used, for example, for analog monitoring of the temperature of the motor windings or bearings or for monitoring the coolant or gear oil temperature. Various sensor types are supported (resistance sensors) for use in solid, liquid or gaseous media:

- PT100/PT1000
- KTY83/KTY84
- NTC

Maximum one temperature module can be connected to one basic unit 2. The same sensor type must be used in all sensor measuring circuits.



3UF7 700-1AA00-0 temperature module

3 inputs for connecting up to 3 resistance sensors in 2-wire or 3-wire circuits

1 Ready LED

2 system interfaces for connection

- to basic unit 2,
- of expansion modules,
- of a current measuring module or current/voltage measuring module,
- of an operator panel.

Expansion with additional inputs/outputs by means of an analog module

Basic unit 2 can be optionally expanded with analog inputs and outputs (0/4 ... 20 mA) by means of the analog module. It is then possible to measure and monitor any process variable that can be mapped on a 0/4 ... 20 mA signal. Typical applications are, for example, level monitoring for the implementation of dry run protection for pumps or monitoring the degree of pollution of a filter using a differential pressure transducer. In this case the automation system has free access to the measured process variables. The analog output can be used, for example, to visualize process variables on a pointer instrument. The automation system also has free access to the output through PROFIBUS.

Maximum one analog module can be connected to one basic unit 2. Both inputs are set to a measuring range of either 0 ... 20 mA or 4 ... 20 mA.



3UF7 400-1AA00-0 analog module

Inputs:

2 inputs, passive, for measuring 0/4 ... 20 mA signals

Outputs:

1 output to output a 0/4 ... 20 mA signal

1 Ready LED

2 system interfaces for connection

- to basic unit 2,
- of expansion modules,
- of a current measuring module or current/voltage measuring module,
- of an operator panel.

SIMOCODE 3UF Motor Management and Control Devices

SIMOCODE pro 3UF7 motor management and control devices

Protective separation

All circuits in SIMOCODE pro are safely separated from each other according to IEC 60947-1, Annex N. That is, they are designed with double creepages and clearances. In the event of a fault, therefore, no parasitic voltages can be formed in neighboring circuits. The instructions of Test Report No. 2668 must be complied with.

EEx e and EEx d types of protection

The overload protection and the thermistor motor protection of the SIMOCODE pro system comply with the requirements for overload protection of explosion-protected motors to the type of protection:

- EEx d "flameproof enclosure" e. g. according to EN 60079-1
- EEx e "increased safety" e. g. according to EN 60079-7

When using SIMOCODE pro devices with a 24 V DC control voltage, electrical separation must be ensured using a battery or a safety transformer according to EN 61558-2-6.

EC type test certificate: BVS 06 ATEX F 001
Test log: BVS PP 05.2029 EG.

Configuration instructions when using an operator panel with display and/or a decoupling module

If you want to use an operator panel with display and/or a decoupling module in the SIMOCODE pro V system, then the following configuration instructions concerning the type and number of connectable expansion modules must be observed.

The following tables show the maximum possible configuration of the expansion modules for the various combinations.

Use of an operator panel with display

Digital module	Digital module	Analog module	Temperature module	Ground-fault module
Only operator panel with display for basic unit 2 (24 V DC or 110 ... 240 V AC/DC)				
Max. 4 expansion modules can be used				
Operator panel with display and current/voltage measurement with basic unit 2 (110 ... 240 V AC/DC)				
Max. 3 expansion modules can be used or:				
--	--	✓	✓	--

Use of a decoupling module (voltage measurement in insulated networks)

Digital module	Digital module	Analog module	Temperature module	Ground-fault module
Basic unit 2 (24 V DC)				
✓ ¹⁾	✓ ¹⁾	✓	✓	✓
Basic unit 2 (110 ... 240 V AC/DC)				
✓	✓	--	✓	✓
✓ ¹⁾	✓ ¹⁾	✓	✓	--
✓	--	✓	✓	--
✓	--	✓	--	✓

Use of a decoupling module (voltage measurement in insulated networks) in combination with an operator panel with display

Digital module	Digital module	Analog module	Temperature module	Ground-fault module
Basic unit 2 (24 V DC)				
✓	--	✓	✓	✓
✓	✓	--	✓	✓
Basic unit 2 (110 ... 240 V AC/DC)				
✓ ²⁾	--	✓	✓	✓
✓	✓	--	--	--
✓ ¹⁾	✓ ¹⁾	✓ ³⁾	--	--
✓	--	--	✓	✓

- ✓ Possible
-- Not possible

¹⁾ No bistable relay outputs and no more than 5 of 7 relay outputs active simultaneously (> 3 s).

²⁾ No bistable relay outputs and no more than 3 of 5 relay outputs active simultaneously (> 3 s).

³⁾ Analog module output is not used.

SIMOCODE pro 3UF7 motor management and control devices

Function

Multifunctional, solid-state full motor protection

Inverse-time delayed overload protection with adjustable tripping characteristics (Classes 5, 10, 15, 20, 25, 30, 35 and 40)

SIMOCODE pro protects induction or AC motors according to IEC 60947-4-1 requirements. The trip class can be adjusted in eight steps from Class 5 to Class 40. In this way, the break time can be adapted very accurately to the load torque which allows the motor to be utilized more effectively. In addition, the time until the overload trip is performed is calculated and can be made available to the I&C system. After an overload trip, the remaining cooling time can be displayed (characteristic curves for 2-pole and 3-pole loading in SIMOCODE pro System Manual).

Phase failure/unbalance protection

The level of the phase unbalance can be monitored and transmitted to the I&C system. If a specified limit value is violated, a defined and delayable response can be initiated. If the phase unbalance is larger than 50 %, the tripping time is also automatically reduced according to the overload characteristic since the heat generation of the motors increases in unbalanced conditions.

Stall protection

If the motor current rises above an adjustable blocking threshold (current threshold), a defined and delayable response can be configured for SIMOCODE pro. In this case, for example, the motor can be shut down independent of the overload protection. The stall protection is only enabled after the configured class time has elapsed and avoids unnecessarily high thermal and mechanical stress as well as wear of the motor.

Thermistor motor protection

This protection function is based on direct temperature measurements by means of temperature sensors in the stator windings or in the enclosure of the motor. These protection functions should be used, in particular, in motors with high switching frequencies, heavy starting, intermittent and/or braking operation, but also in the case of speeds lower than the rated speed. SIMOCODE pro supports connection and evaluation of several PTC sensors connected in series on the basic unit. In addition, the sensor measuring circuit can be monitored for short-circuits and open-circuits. If the temperature of the motor increases beyond a defined limit or if there is a fault in the sensor measuring circuit, a defined response can be configured.

Ground-fault monitoring (internally) with a current measuring module or current/voltage measuring module

SIMOCODE pro acquires and monitors all three phase currents. With vector addition of the phase currents, the motor feeder can be monitored for possible residual currents or ground faults with the help of internal calculations. Internal ground-fault monitoring is only available for motors with three-phase connections in directly grounded networks or in networks grounded with low impedance. The response of SIMOCODE pro when a ground fault is detected can be parameterized and delayed as required.

Ground-fault monitoring (external) with summation current transformer¹⁾³⁾

External ground-fault monitoring is normally implemented for networks that are grounded with high impedance. Using an additional summation current transformer (3UL2 20.-A), even extremely low ground-fault currents can be measured. The response of SIMOCODE pro when a ground fault is detected can be parameterized and delayed as required. Fault current measurement is performed for each summation current transformer for the following fault currents: 0.3/0.5/1 A.

Monitoring of adjustable limit values for the motor current

Current limit monitoring is used for process monitoring independent of overload protection. Violation of a current limit value below the overload threshold can be an indication for a dirty filter in a pump or for an increasingly sluggish motor bearing, for example. Violation of the lower current limit value can be a first indication of a worn drive belt. SIMOCODE pro supports two-step monitoring of the motor current for freely selectable upper and lower current limit values. The response of SIMOCODE pro can be freely parameterized and delayed if it reaches an alarm or tripping threshold.

Voltage monitoring²⁾

By measuring the voltage directly at the circuit breaker or at the fuses in the main circuit, even when the motor is deactivated, SIMOCODE pro can also obtain information about the reclosing capability of the feeder and signal it if required. SIMOCODE pro supports two-stage undervoltage monitoring for freely selectable limit values. The response of SIMOCODE pro can be freely parameterized and delayed if it reaches an alarm or tripping threshold.

Monitoring the active power²⁾

The active power characteristic of a motor provides an accurate statement of the actual loading over the complete range. Excessive loading will cause increased wear in the motor and can result in early failure. Insufficient active power can be an indication of, for example, motor idling. SIMOCODE pro supports two-step monitoring of the active power for freely selectable upper and lower current limit values. The response of SIMOCODE pro can be freely parameterized and delayed if it reaches an alarm or tripping threshold.

Monitoring the power factor²⁾

Especially in the low-end performance range of a motor, the power factor varies more than the motor current or active power. Monitoring of the power factor is therefore particularly useful for distinguishing between motor idling and fault events such as a tear in a drive belt or a crack in a drive shaft. SIMOCODE pro supports two-stage monitoring of power factor undershoot for freely selectable limit values. The response of SIMOCODE pro can be freely parameterized and delayed if it reaches an alarm or tripping threshold.

¹⁾ Using basic unit 2.

²⁾ Using basic unit 2 with current/voltage measuring module.

³⁾ An additional ground-fault module with a 3UL22 summation current transformer is required.

SIMOCODE pro 3UF7 motor management and control devices

Temperature monitoring¹⁾³⁾

The temperature can be monitored, for example, in the motor windings or at the bearings through up to three resistance sensors connected to the temperature module.

SIMOCODE pro supports two-stage monitoring of overheating for freely selectable limit values. The response of SIMOCODE pro can be freely parameterized and delayed if it reaches an alarm or tripping threshold. Temperature monitoring is always performed with reference to the highest temperature of all sensor measuring circuits used.

Monitoring additional process variables over analog inputs (0/4 ... 20 mA)¹⁾⁴⁾

The analog module enables SIMOCODE pro to measure additional process variables and monitor them. A pump can, for example, be protected against dry running in this manner with level monitoring or the degree of pollution of a filter can be measured using a differential pressure transducer. When a specified level is undershot, the pump can be deactivated and when a specified differential pressure is overshoot, the filter can be cleaned. SIMOCODE pro supports two-step monitoring of the corresponding process variable for freely selectable upper and lower current limit values. The response of SIMOCODE pro can be freely parameterized and delayed if it reaches an alarm or tripping threshold.

Phase sequence detection²⁾

By detecting the phase sequence, SIMOCODE pro is able to make a statement about the direction of rotation of a motor. If the direction is incorrect, this can be reported or it can result in immediate disconnection of the affected motor.

Monitoring of operating hours, downtime and number of starts

In order to prevent plant downtime caused by motor failure due to excessive motor operating times (wear) or excessive motor downtimes, SIMOCODE pro can monitor the operating hours and downtime of a motor. When an adjustable limit value is violated, a signal or warning can be generated which can indicate that the corresponding motor must be serviced or replaced. After the motor has been replaced, the operating hours and downtimes can be reset, for example.

To avoid excessive thermal loads and early wear of the motor, it is possible to limit the number of motor startups for a specifiable period. Alarms can indicate that only a small number of possible starts remain.

Flexible motor control implemented with integrated control functions

Many typical motor control functions have been predefined in SIMOCODE pro and are available for use:

- Overload relay
- Direct-on-line and reversing starters
- Wye-delta starters (also with direction reversal)¹⁾
- Two speeds, motors with separate windings (pole-changing switch); also with direction reversal¹⁾
- Two speeds, motors with separate Dahlander windings (also with direction reversal)¹⁾
- Positioner actuation¹⁾
- Solenoid valve actuation¹⁾
- Actuation of a motor starter protector or circuit breaker (MCCB)
- Actuation of a 3RW soft starter also with direction reversal¹⁾

These control programs already include all the software interlocks and logic operations required for operation of the required motor control functions.

It is also monitored whether the current checkback of the motor feeder corresponds with the control command. If not, SIMOCODE pro opens the motor contactor and generates a fault message.

Depending on the application, motor control can be switched over or carried out simultaneously from several control stations, e. g.:

- From the I&C system through PROFIBUS DP
- From a PC or programming device through PROFIBUS DP
- From the control cabinet door through the operator panel
- From a PC or programming device on the system interface through SIMOCODE pro
- From a local control point on the motor. In this case, the buttons, switches and indicator lights are connected to the inputs and outputs of SIMOCODE pro

Regardless of whether a control command is sent to SIMOCODE pro via PROFIBUS DP using the operator panel or via the buttons connected to the binary SIMOCODE pro inputs, SIMOCODE pro can execute these control commands simultaneously or in accordance with the enabled commands defined during parameterization.

These predefined control functions can also be flexibly adapted to each customized configuration of a motor feeder by means of freely configurable logic modules (truth tables, counters, timers, edge evaluation etc.).

In addition, special standard functions are stored in SIMOCODE pro which can also be used to extend the protection and control functions, e. g.:

- Power failure monitoring¹⁾ for automatic, time-staggered restart of motors following a mains failure e. g. with the help of a separate voltage relay (voltage controller).
- Fault signaling modules for external faults with or without manual or automatic acknowledgement for generating internal messages or for tripping SIMOCODE pro in response to freely definable events (e. g. overspeed monitor has been activated). Designations/names can also be assigned to the external faults which are stored in the device and which are therefore also available to the I&C system.
- Emergency start function and reset of the thermal memory of SIMOCODE pro after tripping, i. e. immediate restart is possible (important, for example, for pumps used to extinguish fires).
- Test function for the load feeder circuit when the main control switch is open to test the control circuit while the main circuit is de-energized.

¹⁾ Using basic unit 2.

²⁾ Using basic unit 2 with current/voltage measuring module.

³⁾ An additional temperature module is required.

⁴⁾ An additional analog module is required.

SIMOCODE 3UF Motor Management and Control Devices

SIMOCODE pro 3UF7 motor management and control devices

Detailed operational, service and diagnostics data

SIMOCODE pro provides a variety of operating, service and diagnostics data, such as:

Operating data

- The switching state of the motor (On, Off, clockwise, counter-clockwise, fast, slow) is derived from the current flow in the main circuit, so feedbacks are not required through auxiliary contacts from circuit breakers and contactors
- Current in phase 1, 2, 3 and maximum current in % of the current setting
- Voltage in phases 1, 2, 3 in V²⁾
- Active power in W²⁾
- Apparent power in VA²⁾
- Power factor in %²⁾
- Phase unbalance in %
- Phase sequence²⁾
- Temperature in sensor measuring circuits 1, 2, 3 and maximum temperature in K¹⁾³⁾
- Current values of the analog signals¹⁾⁴⁾
- Time until tripping in sec.
- Temperature rise for motor model in %
- Remaining cooling time of the motor in sec. etc.

Freely configurable logic modules (calculators⁵⁾) can be used for the device-internal conversion of the measured values in SIMOCODE pro V. This means, for example, that temperatures can be transmitted to the automation system in °C or °F.

Service data

- Motor operating hours (can be reset)
- Motor stop times (can be reset)
- Number of motor starts (can be reset)
- Number of remaining permissible motor starts
- Number of overload trips (can be reset)
- Feeder-related power consumption in kWh (can be reset)⁶⁾
- Internal comments, stored in the device for each feeder, e. g. notes for maintenance events etc.

Diagnostics data

- Numerous detailed early warning and fault messages (can also be used for further processing in the device or I&C system)
- Internal device fault logging with time stamp
- Value of the previous tripping current
- Checkback error (e. g. no current flow in the main circuit following ON control command) etc.

Safety-oriented Emergency-Stop monitoring

In principle it is possible with SIMOCODE pro to equip various control functions in addition with Emergency-Stop monitoring in order for them to be safely deactivated according to EN 954, Category 2 or 4.

Note:

Examples of functions can be found at:
<http://www.siemens.com/simocode>

Autonomous operation

An essential feature of SIMOCODE pro is independent execution of all protection and control functions even if communication with the I&C system breaks down. If the bus or automation system fails, the full functionality of the feeder is ensured or a pre-defined response can be initiated, e. g. the feeder can be shut down in a controlled manner or certain configured control mechanisms can be performed (e. g. the direction of rotation can be reversed).

¹⁾ Using basic unit 2.

²⁾ Using basic unit 2 with current/voltage measuring module.

³⁾ An additional temperature module is required.

⁴⁾ An additional analog module is required.

⁵⁾ When using basic unit 2, product version E03 and higher.

⁶⁾ When using basic unit 2, product version E03 and higher, with current/voltage measuring module.

Integration

General

In addition to device function and hardware design, a great deal of emphasis is placed on the ease of communication-capable controls on the user-friendliness of the parameterization software and the ability of the system to be integrated easily into various different system configurations and process automation systems. For this reason, the SIMOCODE pro system provides suitable software tools for consistent, time-saving parameterization, configuration and diagnostics:

- SIMOCODE ES for totally integrated start-up and service
- OM SIMOCODE pro object manager for total integration into SIMATIC S7
- PCS 7 function block library SIMOCODE pro for total integration into PCS 7

SIMOCODE ES

The parameterization software for SIMOCODE pro can be run on a PC or programming device under Windows 2000/XP/Vista.

With SIMOCODE ES, the SIMOCODE pro motor management system provides a user-friendly and clear-cut user interface with which to configure, operate, monitor and test SIMOCODE pro in the field or from a central location through PROFIBUS. By displaying all operating, service and diagnostics data, SIMOCODE ES supplies important information on whether maintenance work is required or, in the event of a fault, helps to prevent faults or to localize and rectify them once they have occurred.

Unnecessary plant downtimes can be prevented by changing parameters online (even during operation). The printing function integrated into SIMOCODE ES allows comprehensive documentation of all parameters according to EN ISO 7200.

In addition the graphical editor enables extremely ergonomic and user-friendly parameterization with Drag & Drop. Inputs and outputs of function blocks can be graphically linked and parameters can be set. The configured functions can be described in greater detail using comments and the device parameterization can be documented graphically – this speeds up start-up and simplifies the plant documentation.

OM SIMOCODE pro object manager

The OM SIMOCODE pro object manager is a component of SIMOCODE ES. In contrast to a conventional GSD file, it enables SIMOCODE ES to be integrated into STEP 7 for convenient device parameterization. By installing SIMOCODE ES and OM SIMOCODE pro on a PC or programming device, which is used to configure the hardware of the SIMATIC S7, SIMOCODE ES can be called directly from the hardware configuration. This allows easy and consistent S7 configuration.

Note: More information can be found in Chapter 12.

PCS 7 function block library for SIMOCODE pro

The SIMOCODE pro PCS 7 function block library can be used for simple and easy integration of SIMOCODE pro into the SIMATIC PCS 7 process control system. The SIMOCODE pro PCS 7 function block library contains the diagnostics and driver blocks corresponding with the diagnostics and driver concept of SIMATIC PCS 7 as well as the elements (symbols and faceplate) required for operator control and process monitoring. The application is integrated by graphic interconnection using the CFC Editor.

The technological and signal processing functions of the SIMOCODE pro PCS 7 function block library are based on the SIMATIC PCS 7 standard libraries (driver blocks, technological blocks) and are optimally tailored to SIMOCODE pro. Users who previously configured motor feeder circuits using conventional technology by means of signal blocks and motor or valve blocks, can now easily switch to the SIMOCODE pro PCS 7 function block library.

The SIMOCODE pro PCS 7 function block library supplied on CD-ROM allows the user to run the required engineering software on the engineering station (single license) including the runtime software for executing the AS modules in an automation system (single license). If the AS modules are to be used in additional automation systems, the corresponding number of runtime licenses are required which are supplied without a data carrier.

System manual for SIMOCODE pro

The SIMOCODE pro system manual describes the motor management system and its functions in detail. It contains information about configuration and commissioning as well as servicing and maintenance. A typical example of a reversing starter application is used to teach the user quickly and practically how to use the system. In addition to help on how to identify and rectify faults in the event of a malfunction, the manual also contains special information for servicing and maintenance.

Furthermore, the manual contains schematics, dimensional drawings and technical specifications of the system components as project planning aids.

SIMOCODE 3UF Motor Management and Control Devices

SIMOCODE pro 3UF7 motor management and control devices

Technical specifications

General data applicable to the basic units, current measuring modules, current/voltage measuring modules, expansion modules, decoupling module and operator panel		
Permissible ambient temperature		
• During operation	°C	-25 ... +60 ¹⁾
• Storage and transport	°C	-40 ... +80 ²⁾
Installation height above sea level		
• Permissible ambient temperature max. +50 °C (no protective separation)	m	≤ 2000
• Permissible ambient temperature max. +40 °C (no protective separation)	m	≤ 3000
• Permissible ambient temperature max. +40 °C (no protective separation)	m	≤ 4000
Degree of protection (acc. to IEC 60529)		
• All components, (except for current measuring modules or current/voltage measuring modules for busbar connection, operator panel and door adapter)		IP20
• Current measuring modules or current/voltage measuring module with busbar connection		IP00
• Operator panel (front) and door adapter (front) with cover		IP54
Shock resistance (sine pulse)	g/ms	15/11
Mounting position		Any
Frequency	Hz	50/60 ±5 %
Immunity to electromagnetic interferences (acc. to IEC 60947-1)		
• Line-induced interference, burst acc. to IEC 61000-4-4	kV	Corresponds to degree of severity 3
	kV	2 (power ports)
	V	1 (signal ports)
• Line-induced interference, high frequency acc. to IEC 61000-4-6	V	10
• Line-induced interference, surge acc. to IEC 61000-4-5	kV	2 (line to earth)
	kV	1 (line to line)
• Electrostatic discharge, ESD acc. to IEC 61000-4-2	kV	8 (air discharge)
	kV	6 ³⁾ (contact discharge)
• Field-related interference acc. to IEC 61000-4-3	V/m	10
Immunity to electromagnetic interference (acc. to IEC 60947-1)		
• Line-conducted and radiated interference emission		EN 55011/EN 55022 (CISPR 11/CISPR 22) (corresponds to degree of severity A)
Protective separation acc. to IEC 60947-1, Annex N		
All circuits in SIMOCODE pro are safely separated from each other acc. to IEC 60947-1, they are designed with doubled creepage paths and clearances		
In this context, compliance with the instructions in the test report "Protective separation" No. 2668 is required.		
Basic units		
Mounting		
Snap-on mounting onto TH 35 standard mounting rail or screw fixing with additional push-in lugs		
Display		
• Red/green/yellow LED "DEVICE"		• Green: "Ready"
		• Red: "Function test not OK; device is disabled"
		• Yellow: "Memory module or addressing plug detected"
		• Off: "No control supply voltage"
• Green "BUS" LED		• Continuous light: "Communication with PLC/PCS"
		• Flashing: "Baud rate recognized/communicating with PC or programming device"
• Red "GEN. FAULT" LED		• Continuous light/flashing: "Feeder fault", e. g. overload trip
Test/Reset buttons		
• Resets the device after tripping		
• Function test		
• Operation of a memory module or addressing plug		
System interface		
• Front		Connection of an operator panel or expansion modules; the memory module, addressing plug or a PC cable can also be connected to the system interface for parameterizing
• Bottom		Connection of a current measuring module or current/voltage measuring module
PROFIBUS DP interface		
Connection of the PROFIBUS DP cable through terminal connection or through a 9-pin sub D socket		

1) For 3UF7 21: 0 ... +60 °C.

2) For 3UF7 21: -20 ... +70 °C.

3) For 3UF7 21: 4 kV.

Basic units

Control circuit

Rated control supply voltage U_s (acc. to EN 61131-2)		110 ... 240 V AC/DC; 50/60 Hz	24 V DC								
Operating range		0.85 ... 1.1 × U_s	0.80 ... 1.2 × U_s								
Power consumption											
• Basic unit 1 (3UF7 000)		7 VA/5 W	5 W								
• Basic unit 2 (3UF7 010)		10 VA/7 W	7 W								
incl. two expansion modules connected to basic unit 2											
Rated insulation voltage U_i	V	300 (at degree of pollution 3)									
Rated impulse withstand voltage U_{imp}	kV	4									
Relay outputs		3 monostable relay outputs									
• Number		Floating NO contacts (NC contact response can be parameterized with internal signal conditioning), 2 relay outputs are jointly and 1 relay output is separately connected to a common potential; they can be freely assigned to the control functions (e. g. for line, star and delta contactors and for signaling the operating state)									
• Auxiliary contacts of the 3 relay outputs		<ul style="list-style-type: none"> • Fuse links, gL/gA operational class 6 A, quick-acting 10 A (IEC 60947-5-1) • Miniature circuit breaker 1.6 A, C characteristic (IEC 60947-5-1) • Miniature circuit breaker 6 A, C characteristic ($I_k < 500$ A) 									
• Specified short-circuit protection for auxiliary contacts (relay outputs)		6									
• Rated uninterrupted current	A	<table border="0"> <tr> <td>AC-15</td> <td>6 A/24 V AC</td> <td>6 A/120 V AC</td> <td>3 A/230 V AC</td> </tr> <tr> <td>DC-13</td> <td>2 A/24 V DC</td> <td>0.55 A/60 V DC</td> <td>0.25 A/125 V DC</td> </tr> </table>		AC-15	6 A/24 V AC	6 A/120 V AC	3 A/230 V AC	DC-13	2 A/24 V DC	0.55 A/60 V DC	0.25 A/125 V DC
AC-15	6 A/24 V AC	6 A/120 V AC	3 A/230 V AC								
DC-13	2 A/24 V DC	0.55 A/60 V DC	0.25 A/125 V DC								
• Rated switching capacity											
Inputs (binary)		4 inputs supplied internally by the device electronics (24 V DC) and connected to a common potential for acquiring process signals (e. g. local control station, key-operated switch, limit switch, ...), freely assignable to the control functions									
Thermistor motor protection (binary PTC)		<ul style="list-style-type: none"> • Summation cold resistance • Response value • Return value 									
	kΩ	≤ 1.5									
	kΩ	3.4 ... 3.8									
	kΩ	1.5 ... 1.65									
Conductor cross-sections		<ul style="list-style-type: none"> • Tightening torque • Solid • Finely stranded with end sleeve • AWG cable (solid) • AWG cable (finely stranded) 									
	Nm	0.8 ... 1.2									
	mm ²	1 × (0.5 ... 4.0); 2 × (0.5 ... 2.5)									
	mm ²	1 × (0.5 ... 2.5); 2 × (0.5 ... 1.5)									
	AWG	1 × AWG 20 to 12/2 × AWG 20 to 14									
	AWG	1 × AWG 20 to 14/2 × AWG 20 to 16									

Current measuring modules or
current/voltage measuring modules

Mounting

- Current setting $I_e = 0.3 ... 3$ A; 2.4 ... 25 A; 10 ... 100 A (3UF7 1.0, 3UF7 1.1, 3UF7 1.2)
- Current setting $I_e = 20 ... 200$ A (3UF7 103, 3UF7 113)
- Current setting $I_e = 63 ... 630$ A (3UF7 104, 3UF7 114)

Snap-on mounting onto 35 mm standard mounting rail or screw fixing with additional push-in lugs
Snap-on mounting onto 35 mm standard mounting rail, screw fixing on mounting plate or direct fixing on contactor
Screw fixing on mounting plate or direct fixing on contactor

System interface

For connection to a basic unit or decoupling module

Main circuit

		3UF7 1.0	3UF7 1.1	3UF7 1.2	3UF7 1.3	3UF7 1.4
Current setting I_e	A	0.3 ... 3	2.4 ... 25	10 ... 100	20 ... 200	63 ... 630
Rated insulation voltage U_i (degree of pollution 3)	V	690 ¹⁾				
Rated operational voltage U_e	V	690				
Rated impulse withstand voltage U_{imp}	kV	6 ²⁾				
Rated frequency	Hz	50/60				
Type of current		Three-phase current				
Short-circuit		Additional short-circuit protection is required in main circuit				
Accuracy of current measurement (in the range 1 x minimum current setting I_u to 8 x max. current setting I_o)	%	±3				
Typical voltage measuring ranges						
• Phase-to-phase voltage/line-to-line voltage (e. g. U_{L1L2})	V	110 ... 690 (only the phase voltages are available in SIMOCODE pro as measured values)				
• Phase voltage (e. g. U_{L1})	V	65 ... 400				
Accuracy						
• Of voltage measurement (phase voltage U_L in the range 230 ... 400 V)	%	±3 (typical)				
• Of power factor measurement (in the rated load range power factor = 0.4 ... 0.8)	%	±5 (typical)				
• Of apparent power measurement (in the rated load range)	%	±5 (typical)				

Notes on voltage measurement

- In non-grounded networks or in networks with integrated insulation measurement or monitoring
- Feeder lines for voltage measurement

In these networks the current/voltage measuring module can be used only with an upstream decoupling module on the system interface.
In the feeder lines from the main circuit for voltage measurement of SIMOCODE pro it may be necessary to provide additional line protection!

1) For 3UF7 103 or 3UF7 104 up to 1000 V.

2) For 3UF7 103 or 3UF7 104 up to 8 kV.

SIMOCODE 3UF Motor Management and Control Devices

SIMOCODE pro 3UF7 motor management and control devices

Current measuring modules or current/voltage measuring modules

Connection for main circuit

Feed-through opening (diameter)

- Current setting $I_e = 0.3 \dots 3 \text{ A}$; $2.4 \dots 25 \text{ A}$
- Current setting $I_e = 10 \dots 100 \text{ A}$
- Current setting $I_e = 20 \dots 200 \text{ A}$

mm 7.5
mm 14.0
mm 25.0

Busbar connections¹⁾

- Current setting I_e
- Terminal screw
- Tightening torque
- Solid with cable lug
- Stranded with cable lug
- AWG cable

	3UF7 100, 3UF7 101, 3UF7 102	3UF7 103, 3UF7 104
A	20 ... 200	63 ... 630
Nm	M8 x 25	M10 x 30
mm ²	10 ... 14	14 ... 24
mm ²	16 ... 95 ²⁾	50 ... 240 ³⁾
mm ²	25 ... 120 ²⁾	70 ... 240 ³⁾
AWG	6 ... 3/0 kcmil	1/0 ... 500 kcmil

Conductor cross-sections for voltage measurement

- Tightening torque
- Solid
- Finely stranded with end sleeve
- AWG cable (solid)
- AWG cable (finely stranded)

Nm 0.8 ... 1.2
mm² 1 x (0.5 ... 4.0); 2 x (0.5 ... 2.5)
mm² 1 x (0.5 ... 2.5); 2 x (0.5 ... 1.5)
AWG 1 x AWG 20 to 12/2 x AWG 20 to 14
AWG 1 x AWG 20 to 14/2 x AWG 20 to 16

Decoupling modules

Mounting

Snap-on mounting onto 35 mm standard mounting rail or screw fixing with additional push-in lugs

Display

- Green "READY" LED

- Continuous light: "Ready"

System interfaces

Left interface for connecting to a basic unit or to an expansion module, right interface only for connecting to a current/voltage measuring module.

Conductor cross-sections

- Tightening torque
- Solid
- Finely stranded with end sleeve
- AWG cable (solid)
- AWG cable (finely stranded)

Nm 0.8 ... 1.2
mm² 1 x (0.5 ... 4.0); 2 x (0.5 ... 2.5)
mm² 1 x (0.5 ... 2.5); 2 x (0.5 ... 1.5)
AWG 1 x AWG 20 to 12/2 x AWG 20 to 14
AWG 1 x AWG 20 to 14/2 x AWG 20 to 16

Digital modules

Mounting

Snap-on mounting onto 35 mm standard mounting rail or screw fixing with additional push-in lugs

Display

- Green "READY" LED

- Continuous light: "Ready"
- Flashing: "No connection to the basic unit"

System interfaces

For connecting to a basic unit, another expansion module, a current measuring module or current/voltage measuring module or to the operator panel

Control circuit

Rated insulation voltage U_i

V 300 (at degree of pollution 3)

Rated impulse withstand voltage U_{imp}

kV 4

Relay outputs

- Number
- Auxiliary contacts of the 2 relay outputs

2 monostable or bistable relay outputs (depending on the version)
Floating NO contacts (NC contact response can be parameterized with internal signal conditioning), all relay outputs are jointly connected to a common potential, they can be freely assigned to the control functions (e. g. for line, wye and delta contactors and for signaling the operating state)

- Fuse links, gL/gG operational class 6 A, quick-acting 10 A (IEC 60947-5-1)
- Miniature circuit breaker 1.6 A, C characteristic (IEC 60947-5-1)
- Miniature circuit breaker 6 A, C characteristic ($I_k < 500 \text{ A}$)

- Specified short-circuit protection for auxiliary contacts (relay outputs)

- Rated uninterrupted current
- Rated switching capacity

A

AC-15	6 A/24 V AC	6 A/120 V AC	3 A/230 V AC
DC-13	2 A/24 V DC	0.55 A/60 V DC	0.25 A/125 V DC

Inputs (binary)

4 externally supplied floating inputs, 24 V DC or 110 ... 240 V AC/DC depending on the version; inputs jointly connected to common potential for sensing process signals (e. g.: local control station, key-operated switch, limit switch ...), freely assignable to the control functions

Conductor cross-sections

- Tightening torque
- Solid
- Finely stranded with end sleeve
- AWG cable (solid)
- AWG cable (finely stranded)

Nm 0.8 ... 1.2
mm² 1 x (0.5 ... 4.0); 2 x (0.5 ... 2.5)
mm² 1 x (0.5 ... 2.5); 2 x (0.5 ... 1.5)
AWG 1 x AWG 20 to 12/2 x AWG 20 to 14
AWG 1 x AWG 20 to 14/2 x AWG 20 to 16

¹⁾ Screw terminal is possible using a suitable 3RT19 ... box terminal.

²⁾ When connecting cable lugs according to DIN 46235, use the 3RT19 56-4EA1 terminal cover for conductor cross-sections from 95 mm² to ensure phase spacing.

³⁾ When connecting cable lugs according to DIN 46234 for conductor cross-sections from 240 mm² as well as DIN 46235 for conductor cross-sections from 185 mm², use the 3RT19 66-4EA1 terminal cover to ensure phase spacing.

Ground-fault modules**Mounting**

Snap-on mounting onto 35 mm standard mounting rail or screw fixing with additional push-in lugs

Display

- Green "READY" LED

- Continuous light: "Ready"
- Flashing: "No connection to the basic unit"

System interfaces

For connecting to a basic unit, another expansion module, a current measuring module or current/voltage measuring module or to the operator panel

Control circuit**Connectable 3UL22 summation current transformer with rated fault currents I_N**

A

0.3/0.5/1

- $I_{\text{Ground fault}} \leq 50 \% I_N$
- $I_{\text{Ground fault}} \geq 100 \% I_N$

No tripping
Tripping**Response delay (conversion time)**

ms

300 ... 500, additionally delayable

Conductor cross-sections

- Tightening torque
- Solid
- Finely stranded with end sleeve
- AWG cable (solid)
- AWG cable (finely stranded)

Nm

0.8 ... 1.2

mm²

1 × (0.5 ... 4.0); 2 × (0.5 ... 2.5)

mm²

1 × (0.5 ... 2.5); 2 × (0.5 ... 1.5)

AWG

1 × AWG 20 to 12/2 × AWG 20 to 14

AWG

1 × AWG 20 to 14/2 × AWG 20 to 16

Temperature modules**Mounting**

Snap-on mounting onto 35 mm standard mounting rail or screw fixing with additional push-in lugs

Display

- Green "READY" LED

- Continuous light: "Ready"
- Flashing: "No connection to the basic unit"

System interfaces

For connecting to a basic unit, another expansion module, a current measuring module or current/voltage measuring module or to the operator panel

Sensor circuit**Typical sensor circuits**

- PT100
- PT1000/KTY83/KTY84/NTC

mA

1 (typical)

mA

0.2 (typical)

Open-circuit/short-circuit detection

- For sensor type
- Open circuit
- Short-circuit
- Measuring range

PT100/PT1000

KTY83-110

KTY84

NTC

✓

✓

✓

--

-50 ... +500

-50 ... +175

-40 ... +300

+80 ... +160

Measuring accuracy at 20 °C ambient temperature (T20)

K

< ±2

Deviation due to ambient temperature (in % of measuring range)

%

0.05 per K deviation from T20

Conversion time

ms

500

Connection type

Two- or three-wire connection

Conductor cross-sections

- Tightening torque
- Solid
- Finely stranded with end sleeve
- AWG cable (solid)
- AWG cable (finely stranded)

Nm

0.8 ... 1.2

mm²

1 × (0.5 ... 4.0); 2 × (0.5 ... 2.5)

mm²

1 × (0.5 ... 2.5); 2 × (0.5 ... 1.5)

AWG

1 × AWG 20 to 12/2 × AWG 20 to 14

AWG

1 × AWG 20 to 14/2 × AWG 20 to 16

- ✓ Detection possible
- Detection not possible

SIMOCODE 3UF Motor Management and Control Devices

SIMOCODE pro 3UF7 motor management and control devices

Analog modules	
Mounting	Snap-on mounting onto 35 mm standard mounting rail or screw fixing with additional push-in lugs
Display • Green "READY" LED	<ul style="list-style-type: none"> • Continuous light: "Ready" • Flashing: "No connection to the basic unit"
System interfaces	For connecting to a basic unit, another expansion module, a current measuring module or current/voltage measuring module or to the operator panel
Control circuit	
Inputs	
• Channels	2 (passive)
• Parameterizable measuring ranges	0/4...20
• Shielding	Up to 30 m shield recommended, from 30 m shield required
• Max. input current (destruction limit)	40
• Accuracy	% ±1
• Input resistance	Ω 50
• Conversion time	ms 150
• Resolution	bit 12
• Open-circuit detection	With measuring range 4 ... 20 mA
Output	
• Channels	1
• Parameterizable output range	0/4...20
• Shielding	Up to 30 m shield recommended, from 30 m shield required
• Max. voltage at output	30 V DC
• Accuracy	% ±1
• Max. output load	Ω 500
• Conversion time	ms 25
• Resolution	bit 12
• Short-circuit resistant	Yes
Connection type	Two-wire connection
Electrical separation of inputs/output to the device electronics	No
Conductor cross-sections	
• Tightening torque	Nm 0.8...1.2
• Solid	mm ² 1 x (0.5...4.0); 2 x (0.5...2.5)
• Finely stranded with end sleeve	mm ² 1 x (0.5...2.5); 2 x (0.5...1.5)
• AWG cable (solid)	AWG 1 x AWG 20 to 12/2 x AWG 20 to 14
• AWG cable (finely stranded)	AWG 1 x AWG 20 to 14/2 x AWG 20 to 16
Operator panels	
Mounting	Mounted in a control cabinet door or in a front panel, IP54 with system interface cover
Display • Red/green/yellow LED "DEVICE"	<ul style="list-style-type: none"> • Green: "Ready" • Green flashing: "No connection to the basic unit" • Red: "Function test not OK; device is disabled" • Yellow: "Memory module or addressing plug detected" • Off: "No control supply voltage" • Continuous light: "Communication with PLC/PCS" • Flashing: "Baud rate recognized/communicating with PC or programming device" • Continuous light/flashing: "Feeder fault", e. g. overload trip
• Green "BUS" LED	For assigning to any status signals, as required
• Red "GEN. FAULT" LED	
• Green or yellow LEDs	
Keys • Test/Reset	<ul style="list-style-type: none"> • Resets the device after tripping • Function test • Operation of a memory module or addressing plug
• Control keys	For controlling the motor feeder, user-assignable
System interface	
• Front	For plugging in a memory module, an addressing plug or a PC cable for parameterization
• Rear	Connection to the basic unit or to an expansion module

Operator panels with display

Mounting	Mounted in a control cabinet door or in a front panel, IP54 with system interface cover
Display <ul style="list-style-type: none"> • Red/green/yellow LED "DEVICE" • Green "BUS" LED • Red "GEN. FAULT" LED • 4 green LEDs 	<ul style="list-style-type: none"> • Green: "Ready" • Green flashing: "No connection to the basic unit" • Red: "Function test not OK; device is disabled" • Yellow: "Memory module or addressing plug detected" • Off: "No control supply voltage" • Continuous light: "Communication with PLC/PCS" • Flashing: "Baud rate recognized/communicating with PC or programming device" • Continuous light/flashing: "Feeder fault", e. g. overload trip <p>For assigning to any status signals as required (preferably for the feedback of switching states, e. g. On, Off, Left, Right, etc.)</p>
Displays	Graphic display for indicating current measured values, operational and diagnostics data or status information
Keys <ul style="list-style-type: none"> • Control keys • Arrow keys • Softkeys 	<p>For controlling the motor feeder, user-assignable</p> <p>Navigation in the display menu</p> <p>Various menu-dependent functions, e. g. test, reset, operation of a memory module or addressing plug</p>
System interface <ul style="list-style-type: none"> • Front • Rear 	<p>For plugging in a memory module, an addressing plug or a PC cable for parameterization</p> <p>Connection to the basic unit or to an expansion module</p>

SIMOCODE 3UF Motor Management and Control Devices

SIMOCODE pro 3UF7 motor management and control devices

Short-circuit protection with fuses for motor feeders for short-circuit currents up to 50 kA and 690 V for 3UF7

Current measuring module or current/voltage measuring module	Contactors Type	CLASS 5 and Class 10			CLASS 15			CLASS 20			CLASS 25		
		Rated operational current $I_{\theta}/AC-3$ in A at ... V											
		400	500	690	400	500	690	400	500	690	400	500	690
Current setting 0.3 ... 3.0 A													
3UF7 1.0-1AA00-0	3RT10 15	3.0	3.0	3.0	3.0	3.0	3.0	3.0	3.0	3.0	3.0	3.0	3.0
	3RT10 16	3.0	3.0	3.0	3.0	3.0	3.0	3.0	3.0	3.0	3.0	3.0	3.0
Current setting 2.4 ... 25 A													
3UF7 1.1-1AA00-0	3RT10 15	7.0	5.0	4.0	7.0	5.0	4.0	7.0	5.0	4.0	7.0	5.0	4.0
	3RT10 16	9.0	6.5	5.2	9.0	6.5	5.2	9.0	6.5	5.2	9.0	6.5	5.2
	3RT10 17	12.0	9.0	6.3	11.0	9.0	6.3	10.0	9.0	6.3	9.5	9.0	6.3
	3RT10 23	9.0	6.5	5.2	9.0	6.5	5.2	9.0	6.5	5.2	--	--	--
	3RT10 24	12.0	12.0	9.0	12.0	12.0	9.0	12.0	12.0	9.0	12.0	12.0	9.0
	3RT10 25	17.0	17.0	13.0	17.0	17.0	13.0	16.0	16.0	13.0	15.0	15.0	13.0
	3RT10 26	25.0	18.0	13.0	18.0	18.0	13.0	16.0	16.0	13.0	15.0	15.0	13.0
	3RT10 34	25.0	25.0	20.0	25.0	25.0	20.0	22.3	22.3	20.0	20.3	20.3	20.3
	3RT10 35	25.0	25.0	24.0	25.0	25.0	24.0	25.0	25.0	24.0	25.0	25.0	24.0
	Current setting 10 ... 100 A												
3UF7 1.2-1AA00-0	3RT10 34	32.0	32.0	20.0	25.5	25.5	20.0	22.3	22.3	20.0	20.3	20.3	20.0
	3RT10 35	40.0	40.0	24.0	33.0	33.0	24.0	29.4	29.4	24.0	28.0	28.0	24.0
	3RT10 36	50.0	50.0	24.0	38.5	38.5	24.0	32.7	32.7	24.0	29.4	29.4	24.0
	3RT10 44	65.0	65.0	47.0	56.0	56.0	47.0	49.0	49.0	47.0	45.0	45.0	45.0
	3RT10 45	80.0	80.0	58.0	61.0	61.0	58.0	53.0	53.0	53.0	47.0	47.0	47.0
	3RT10 46	95.0	95.0	58.0	69.0	69.0	58.0	59.0	59.0	58.0	53.0	53.0	53.0
	3RT10 54	100.0	100.0	100.0	93.2	93.2	93.2	81.7	81.7	81.7	74.8	74.8	74.8
	3RT10 55	--	--	--	100.0	100.0	100.0	100.0	100.0	100.0	97.5	97.5	97.5
	Current setting 20 ... 200 A												
3UF7 1.3-1.A00-0	3RT10 54	115	115	115	93.2	93.2	93.2	81.7	81.7	81.7	74.8	74.8	74.8
	3RT10 55	150	150	150	122	122	122	107	107	107	98	98	98
	3RT10 56	185	185	170	150	150	150	131	131	131	120	120	120
Current setting 63 ... 630 A													
3UF7 1.4-1BA00-0	3RT10 64	225	225	225	182	182	182	160	160	160	146	146	146
	3RT10 65	265	265	265	215	215	215	188	188	188	172	172	172
	3RT10 66	300	300	280	243	243	243	213	213	213	195	195	195
	3RT10 75	400	400	400	324	324	324	284	284	284	260	260	260
	3RT10 76	500	500	450	405	405	405	355	355	355	325	325	325
	3RT12 64	225	225	225	225	225	225	225	225	225	194	194	194
	3RT12 65	265	265	265	265	265	265	265	265	265	228	228	228
	3RT12 66	300	300	300	300	300	300	300	300	300	258	258	258
	3RT12 75	400	400	400	400	400	400	400	400	400	344	344	344
	3RT12 76	500	500	500	500	500	500	500	500	500	430	430	430
	3TF68 ¹⁾	630	630	630	502	502	502	440	440	440	408	408	408
	3TF69 ¹⁾	630	630	630	630	630	630	572	572	572	531	531	531

¹⁾ Contactor cannot be mounted.

SIMOCODE 3UF Motor Management and Control Devices

SIMOCODE pro 3UF7 motor management and control devices

Current measuring module or current/voltage measuring module	Contactors	CLASS 30			CLASS 35			CLASS 40			Fuse links ¹⁾		British Standard fuses BS 88	
		400 V	500 V	690 V	400 V	500 V	690 V	400 V	500 V	690 V	690 V	690 V		415 V
											LV HRC Type 3NA	Type 3ND		
											DIAZED Type 5SB			
											NEOZED Type 5SE			
											Operational class gG	aM		
											Type of coordination ²⁾			
											ToC 1	ToC 2		
											1	2		
Rated operational current I_n/AC-3 in A at ... V														
Type		400 V	500 V	690 V	400 V	500 V	690 V	400 V	500 V	690 V	690 V	690 V	415 V	
Current setting 0.3 ... 3.0 A														
3UF7 1.0-1AA00-0	3RT10 15	3.0	3.0	3.0	3.0	3.0	3.0	3.0	3.0	3.0	35	20	--	20
	3RT10 16	3.0	3.0	3.0	3.0	3.0	3.0	3.0	3.0	3.0	35	20	--	20
Current setting 2.4 ... 25 A														
3UF7 1.1-1AA00-0	3RT10 15	7.0	5.0	4.0	7.0	5.0	4.0	7.0	5.0	4.0	35	20	--	20
	3RT10 16	9.0	6.5	5.2	9.0	6.5	5.2	8.5	6.5	5.2	35	20	--	20
	3RT10 17	9.0	9.0	6.3	9.0	9.0	6.3	8.5	8.5	6.3	35	20	--	20
	3RT10 23	--	--	--	--	--	--	--	--	--	63	25	--	25
	3RT10 24	12.0	12.0	9.0	12.0	12.0	9.0	12.0	12.0	9.0	63	25	20	25
	3RT10 25	14.0	14.0	13.0	13.0	13.0	13.0	12.0	12.0	12.0	63	25	20	25
	3RT10 26	14.0	14.0	13.0	13.0	13.0	13.0	12.0	12.0	12.0	100	35	20	25
	3RT10 34	19.1	19.1	19.1	17.6	17.6	17.6	16.1	16.1	16.1	125	63	50	63
	3RT10 35	25.0	25.0	24.0	25.0	25.0	24.0	23.5	23.5	23.5	125	63	50	63
	Current setting 10 ... 100 A													
3UF7 1.2-1AA00-0	3RT10 34	19.1	19.1	19.1	17.6	17.6	17.6	16.1	16.1	16.1	125	63	50	63
	3RT10 35	26.5	26.5	24.0	25.0	25.0	24.0	23.5	23.5	23.5	125	63	50	80
	3RT10 36	26.5	26.5	24.0	25.0	25.0	24.0	23.5	23.5	23.5	160	80	50	80
	3RT10 44	41.7	41.7	41.7	38.2	38.2	38.2	34.5	34.5	34.5	200	125	63	125
	3RT10 45	45.0	45.0	45.0	43.0	43.0	43.0	40.0	40.0	40.0	200	160	80	160
	3RT10 46	50.0	50.0	50.0	47.0	47.0	47.0	44.0	44.0	44.0	200	160	100	160
	3RT10 54	69.0	69.0	69.0	63.0	63.0	63.0	57.0	57.0	57.0	355	315	160	250
	3RT10 55	90.0	90.0	90.0	82.0	82.0	82.0	74.0	74.0	74.0	355	315	200	315
	Current setting 20 ... 200 A													
	3UF7 1.3-1A00-0	3RT10 54	69.0	69.0	69.0	64.0	64.0	64.0	--	--	--	355	315	160
3RT10 55		90	90	90	82	82	82	74	74	74	355	315	200	315
3RT10 56		111	111	111	102	102	102	93	93	93	355	315	200	315
Current setting 63 ... 630 A														
3UF7 1.4-1BA00-0	3RT10 64	135	135	135	126	126	126	--	--	--	500	400	250	400
	3RT10 65	159	159	159	146	146	146	133	133	133	500	400	315	400
	3RT10 66	180	180	180	165	165	165	150	150	150	500	400	315	400
	3RT10 75	240	240	240	220	220	220	200	200	200	630	500	400	450
	3RT10 76	300	300	300	275	275	275	250	250	250	630	500	500	500
	3RT12 64	173	173	173	152	152	152	131	131	131	500	500	400	450
	3RT12 65	204	204	204	180	180	180	156	156	156	500	500	400	450
	3RT12 66	231	231	231	204	204	204	177	177	177	500	500	400	450
	3RT12 75	316	316	316	--	--	--	--	--	--	800	800	630	800
	3RT12 76	385	385	385	340	340	340	316	316	316	800	800	630	800
	3TF68 ³⁾	376	376	376	344	344	344	317	317	317	800	500 ⁴⁾	630	500
	3TF69 ³⁾	500	500	500	469	469	469	438	438	438	800	630 ⁴⁾	630	630

- 1) Note the operational voltage.
- 2) Assignment and short-circuit protective devices according to IEC 60947-4-1.
- 3) Contactor cannot be mounted.
- 4) Ensure that the maximum AC-3 operational current is sufficiently different from the rated fuse current.

ToC 1

Type of coordination "1"

Contactors or starters must not endanger persons or equipment in the event of a short-circuit. They do not have to be suitable for further operation without repair and the renewal of parts.

ToC 2

Type of coordination "2"

Contactors or starters must not endanger persons or equipment in the event of a short-circuit and must be suitable for continued use. There is a risk of contact welding.

These types of coordination are indicated in the Technical specifications by orange backgrounds.

SIMOCODE 3UF Motor Management and Control Devices

SIMOCODE pro 3UF7 motor management and control devices

Dimensional drawings

Basic unit 1, SIMOCODE pro C, 3UF7 000

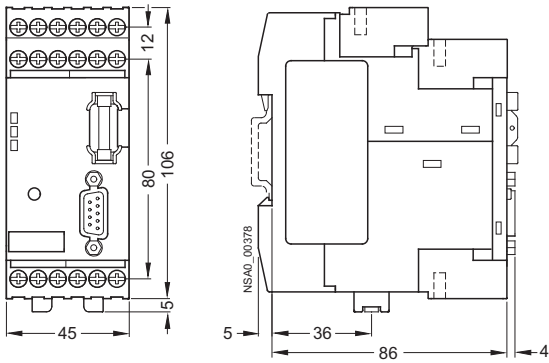

Basic unit 2, SIMOCODE pro V, 3UF7 010

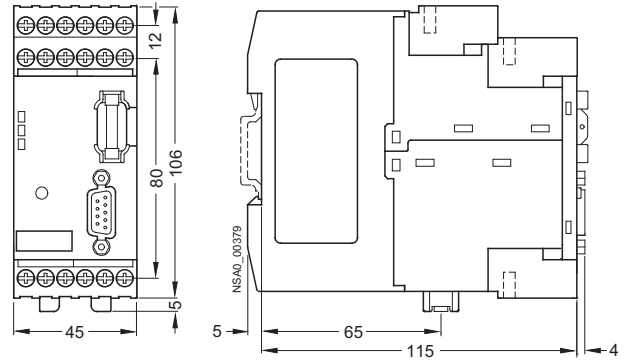

3UF7 100, 3UF7 101 current measuring module (straight-through transformer)

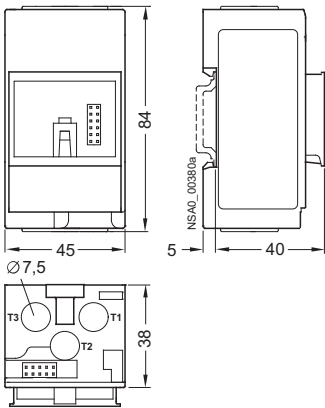

3UF7 102 current measuring module (straight-through transformer)

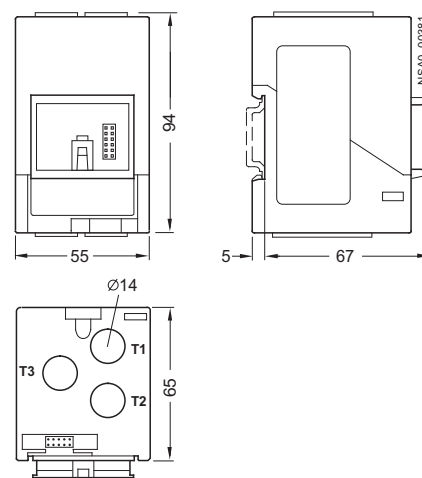

3UF7 103 current measuring module (straight-through transformer)

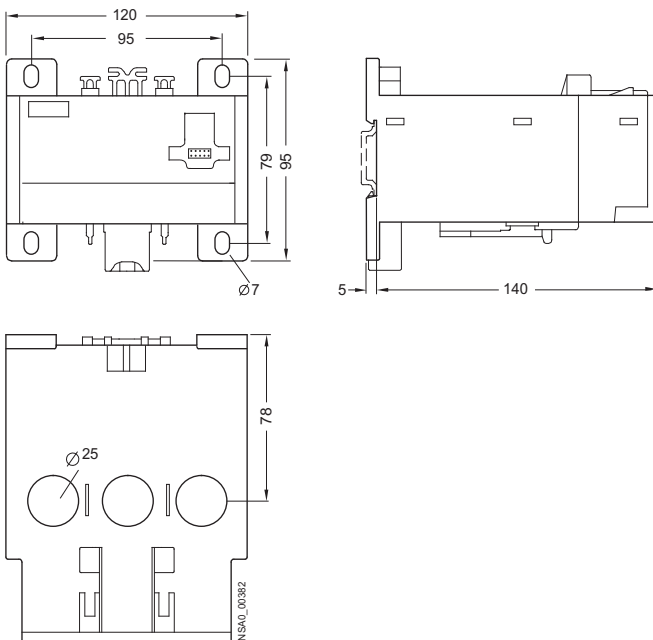

7

3UF7 103 current measuring module (busbar connection)

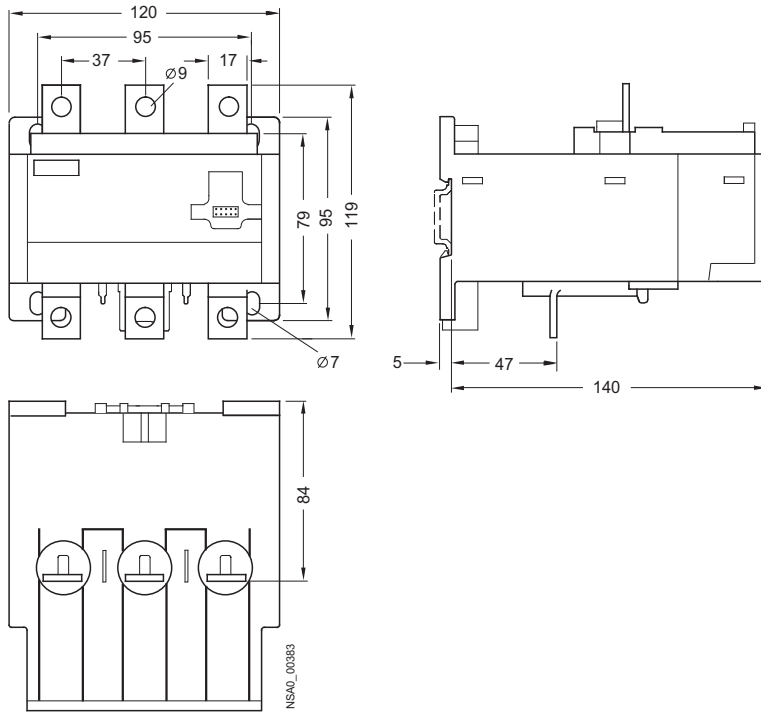

3UF7 104 current measuring module (busbar connection)

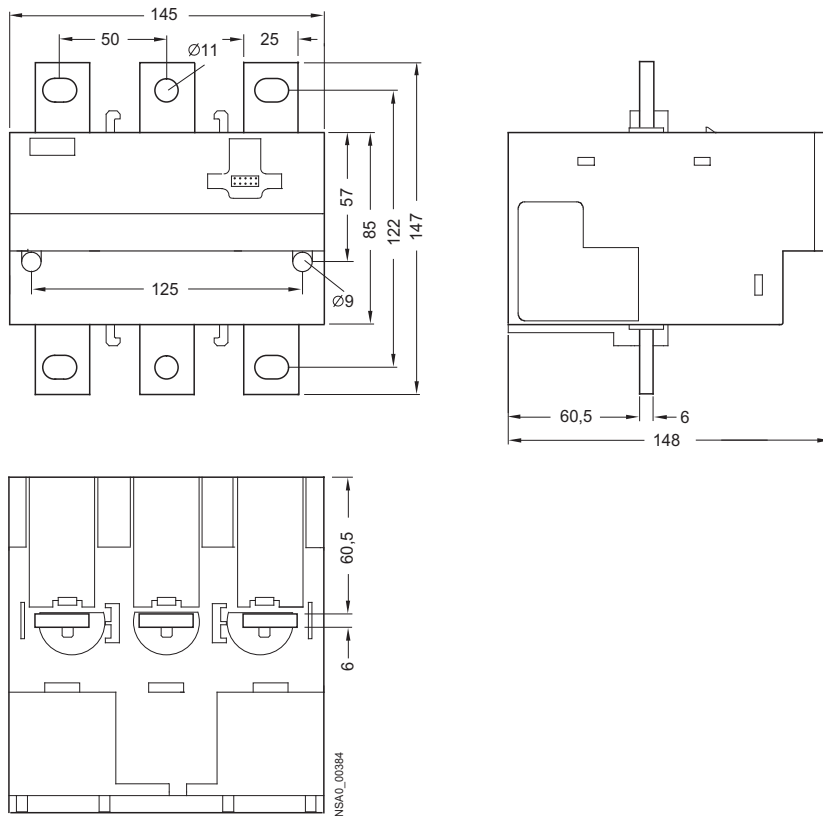

SIMOCODE 3UF Motor Management and Control Devices

SIMOCODE pro 3UF7 motor management and control devices

3UF7 110, 3UF7 111 current/voltage measuring module (straight-through transformer)

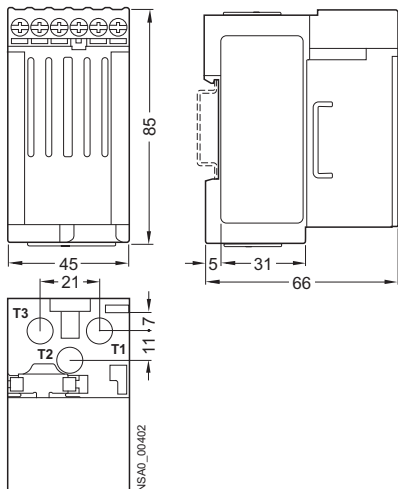

3UF7 112 current/voltage measuring module (straight-through transformer)

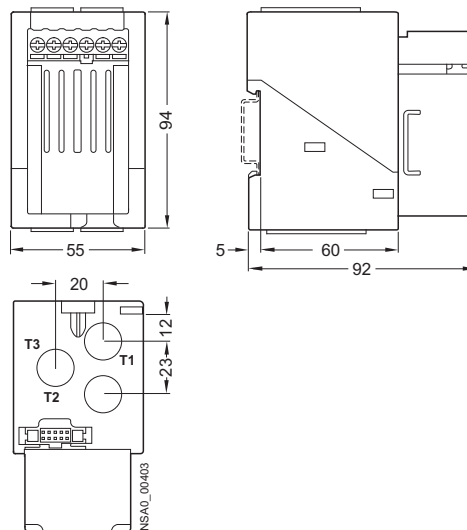

3UF7 113 current/voltage measuring module (straight-through transformer)

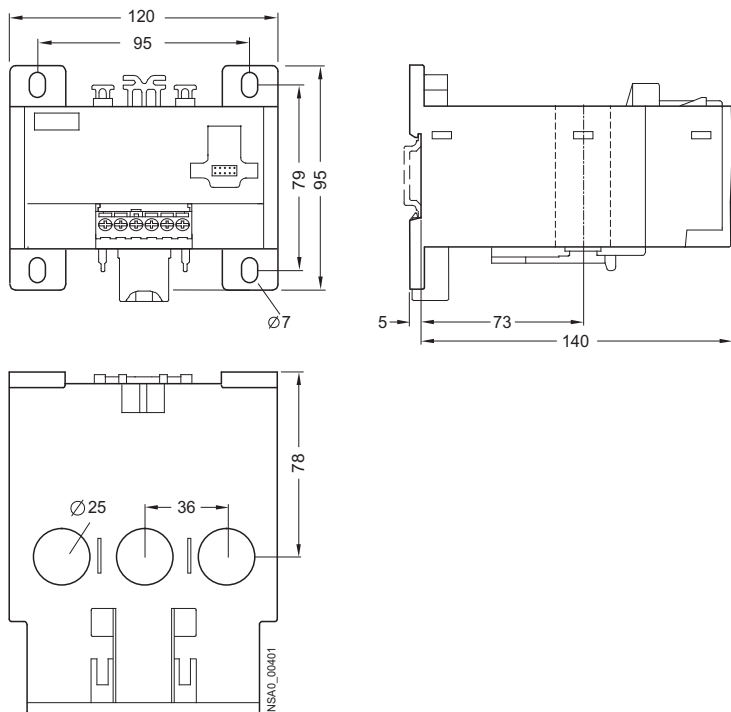

7

SIMOCODE pro 3UF7 motor management and control devices

3UF7 113 current/voltage measuring module (busbar connection)

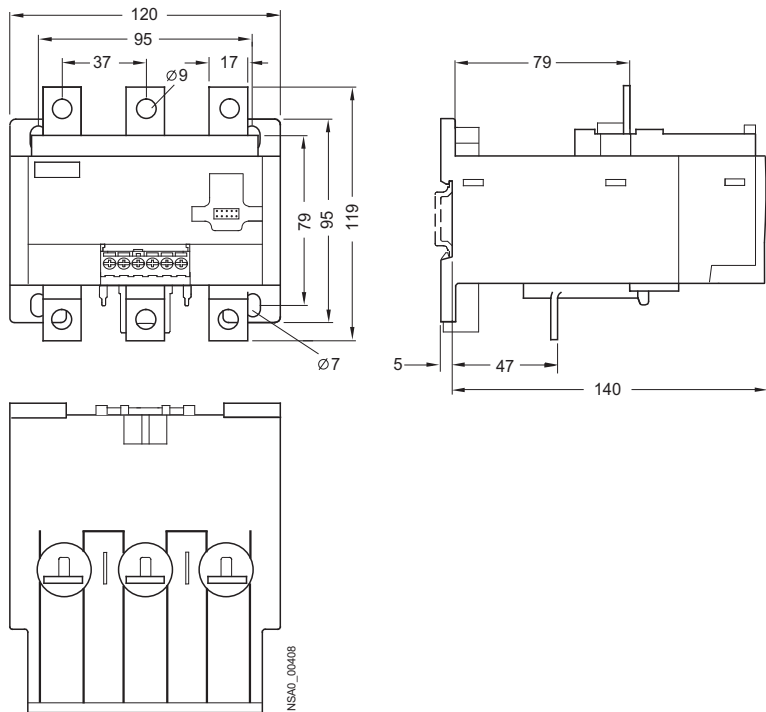

3UF7 114 current/voltage measuring module (busbar connection)

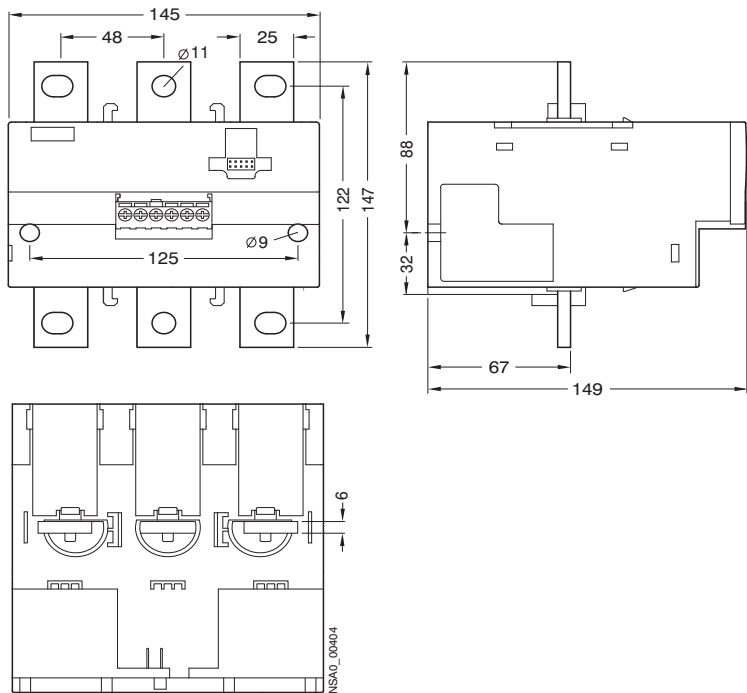

SIMOCODE 3UF Motor Management and Control Devices

SIMOCODE pro 3UF7 motor management and control devices

3UF7 200 operator panel

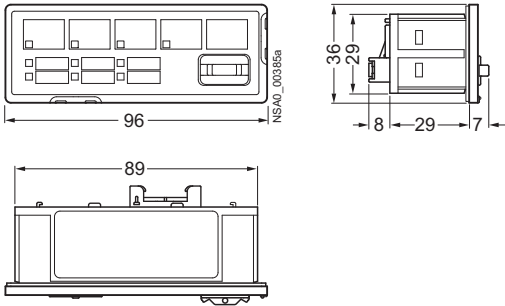

3UF7 920 door adapter

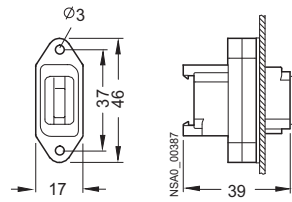

3UF7 210 operator panel with display

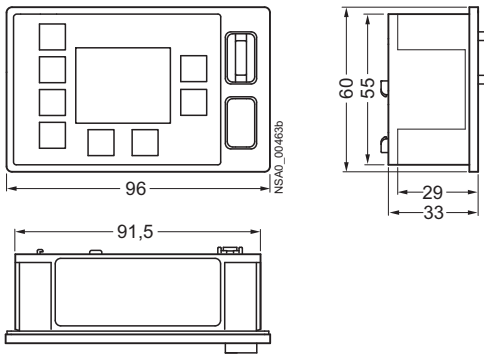

**3UF7 3 digital module
3UF7 4 analog module
3UF7 5 ground-fault module
3UF7 7 temperature module
3UF7 15 decoupling module**

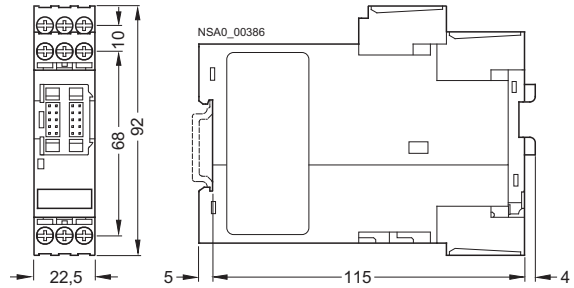

3UF7 922 adapter for operator panel

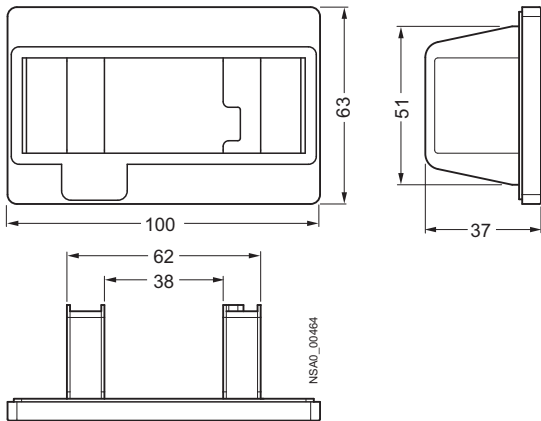

7

SIMOCODE 3UF Motor Management and Control Devices

SIMOCODE pro 3UF7 motor management and control devices

Schematics

Reversing starter with SIMOCODE pro

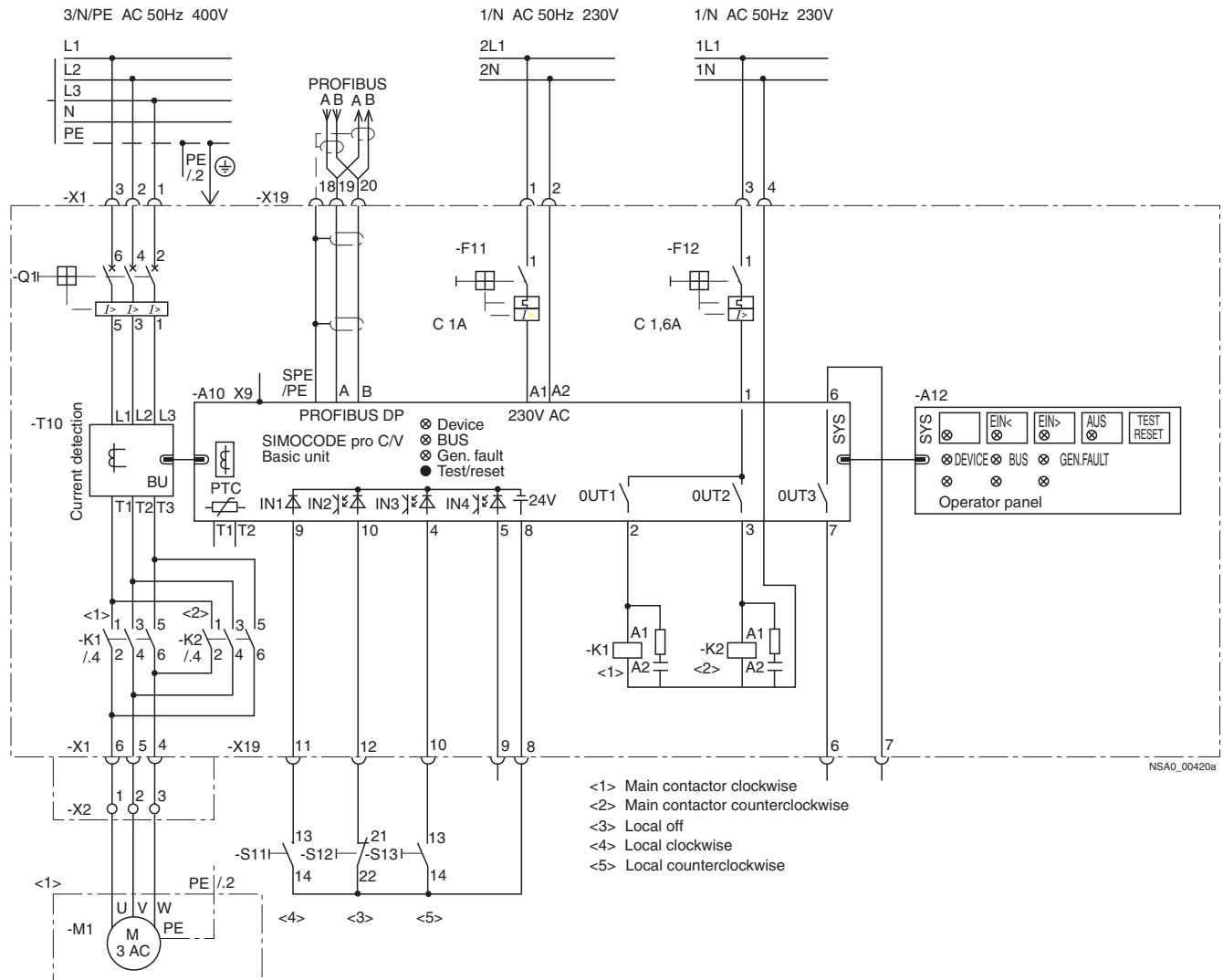

Circuit diagrams for additional control functions can be referred to in the SIMOCODE pro system manual

More information

System manual

For selection of equipment and for configuration, it is recommended that the 3UF7 970-0AA0.-0 system manual is consulted.

Internet

You can find further information on the Internet at: <http://www.siemens.com/simocode>

SIMOCODE 3UF Motor Management and Control Devices

3UF18 current transformers for overload protection

Overview

The 3UF18 current transformers are protection transformers and are used for actuating overload relays. Protection transformers are designed to ensure proportional current transfer up to a mul-

tipole of the primary rated current. The 3UF18 current transformers convert the maximum current of the corresponding operating range into the standard value of 1 A secondary.

Technical specifications

Climatic environmental conditions							
Temperatures							
• Operation	°C -25 ... +60						
• Storage/transport	°C -40 ... +85						
Temperature changes							
• Operation	°C/h Max. 10						
• Storage/transport	°C/h Max. 20						
Relative humidity	% 15 ... 95 (indoor, acc. to IEC 60721-3, no condensation)						
Air pressure							
• Operation	hPa 860 ... 1060						
• Storage/transport	hPa 650 ... 1060						
Contaminants							
• SO ₂	ppm 0.5 (relative humidity ≤ 60 %, no condensation)						
• H ₂ S	ppm 0.1 (relative humidity ≤ 60 %, no condensation)						
Mechanical environmental conditions							
Vibrations (acc. to IEC 60068-2-6)							
	Hz 10 ... 57 (for constant amplitude 0.15 m)						
	Hz 57 ... 150 (for constant acceleration 2 g)						
Shock (acc. to IEC 60068-2-27)							
12 shocks (half-sine 15 g/11 ms)							
Requirements acc. to IEC and EN							
Degree of protection (acc. to IEC 60529)	IP20						
Rated insulation voltage	V 690/1000 (type-dependent)						
Rating of the insulation (acc. to UL/CSA)	V 600						
Trip class (acc. to IEC 60947-4-1)	Suitable from CLASS 5 to CLASS 30						
Power loss per conducting path of the transformers	Operating range	For setting ...					
		To the lower limit	To the upper limit				
	A	mW (mVA)	mW (mVA)				
• 3UF18 45	12.5 ... 50	33 (38)	570 (650)				
• 3UF18 48	25 ... 100	110 (120)	1700 (1900)				
• 3UF18 50	32 ... 130	135 (150)	2400 (2700)				
• 3UF18 52	50 ... 200	170 (190)	2600 (2900)				
• 3UF18 56	100 ... 400	450 (500)	6500 (7000)				
• 3UF18 57	125 ... 500	850 (940)	13000 (15000)				
• 3UF18 68-3F	160 ... 630	900 (1000)	17000 (19000)				
• 3UF18 68-3G	205 ... 820	1400 (1600)	22000 (25000)				
Conductor cross-sections (one or two conductors can be connected)		Current transformers					
		On secondary side	On primary side				
			3UF18 45 3UF18 48 ¹⁾ 3UF18 50 ¹⁾	3UF18 52	3UF18 56 3UF18 57 ²⁾	3UF18 68- 3FA00 ²⁾ M 10	3UF18 68- 3GA00 ²⁾ M 12
• Terminal screw		M 3.5		M 8			
• Solid	mm ²	2 × 1.5 ... 2.5		--	--	--	--
• Stranded	mm ²	2 × 1.5 ... 2.5		--	--	--	--
• Finely stranded without end sleeve	mm ²	--		--	--	--	--
• Finely stranded with end sleeve	mm ²	2 × 1.5		--	--	--	--
• Finely stranded with cable lug	mm ²	--		35 ... 95	50 ... 240 ³⁾	50 ... 240	185 ... 240
• Stranded with cable lug	mm ²	--		50 ... 120	70 ... 240 ³⁾	70 ... 240	185 ... 240
• Connecting bars	mm	--		20 × 4	25 × 6.30 × 6	30 × 5	50 × 5
• Tightening torque	Nm	0.8 ... 1.4		10 ... 14	14 ... 24	14 ... 24	14 ... 24
• Tightening torque	lb	7 ... 12		89 ... 124	124 ... 210	124 ... 210	124 ... 210

¹⁾ With or without box terminal.

²⁾ Conductor cross-sections for box terminals, see 3TF68 and 3TF69 contactors in the section "Contactors and Contactor Assemblies".

³⁾ With max. conductor cross-section, a terminal cover for maintaining the phase spacing is required.

SIMOCODE 3UF Motor Management and Control Devices

3UF18 current transformers
for overload protection

Short-circuit protection with fuses for motor feeders
for short-circuit currents up to 50 kA at 690 V³⁾, 50/60 Hz

Overload relay	Contactors	Rated operational current I_e AC-3 in A with 400 V and Class ...					Type of coordination 1 ²⁾	Type of coordination 2 ²⁾		
		5 and 10	15	20	25	30		Fuse links in A ¹⁾		
						LV HRC, type 3NA DIAZED, type 5SB NEOZED, type 5SE gL/gG	LV HRC, type 3NA DIAZED, type 5SB NEOZED, type 5SE gL/gG	LV HRC, type 3ND aM	British Standards fuses BS 88	
Operating range 0.25 ... 2.5 A										
3UF18 43-1BA00	3RT10 15	2.5	2.5	2.5	2.5	2.5	25	10	--	--
Operating range 1.25 ... 12.5 A										
3UF18 43-1AA00	3RT10 15	7	7	7	7	7	25	10	--	--
	3RT10 16	9	9	9	9	9	25	10	--	--
	3RT10 17	12	11	10	9.5	9	25	10	--	--
	3RT10 24	12	12	12	12	12	35	16	20	35
	3RT10 25	12.5	12.5	12.5	12.5	12.5	35	16	20	35
Operating range 2.5 ... 25 A										
3UF18 43-2BA00	3RT10 15	7	7	7	7	7	25	10	--	--
	3RT10 16	9	9	9	9	9	25	10	--	--
	3RT10 17	12	11	10	9.5	9	25	10	--	--
	3RT10 24	12	12	12	12	12	63	25	20	35
	3RT10 25	17	17	16	15	14	63	25	20	35
	3RT10 26	25	18	16	15	14	63	25	35	50
	3RT10 34	--	25	22.3	20.3	19.1	63	25	--	--
	3RT10 35	--	--	25	25	25	63	25	--	--
	Operating range 12.5 ... 50 A									
	3UF18 45-2CA00	3RT10 25	17	17	16	15	14	63	25	20
3RT10 26		25	18	16	15	14	100	35	35	50
3RT10 34		32	25.5	22.3	20.3	19.1	100	63	--	--
3RT10 35		40	33	29.4	28	26.5	100	63	--	--
3RT10 36		50	38.5	32.7	29.4	26.5	100	80	--	--
3RT10 44		--	50	49	45	41.7	100	80	--	--
3RT10 45		--	--	50	47	45	100	80	--	--
3RT10 46		--	--	--	50	50	100	80	--	--
Operating range 16 ... 65 A										
3UF18 47-2DA00	3RT10 34	32	25.5	22.3	20.3	19.1	125	63	--	--
	3RT10 35	40	33	29.4	28	26.5	125	63	--	--
	3RT10 36	50	38.5	32.7	29.4	26.5	160	80	--	--
	3RT10 44	65	56	49	45	41.7	160	125	--	--
	3RT10 45	65	61	53	47	45	160	125	--	--
	3RT10 46	--	65	59	53	50	160	125	--	--
	3RT10 54	65	65	65	65	65	160	125	--	--
Operating range 25 ... 100 A										
3UF1 848-2EA00	3RT10 44	65	65	49	45	41.7	250	125	--	--
	3RT10 45	80	61	53	47	45	250	160	--	--
	3RT10 46	95	69	59	53	50	250	160	--	--
	3RT10 54	100	93	82	75	69	250	160	125	125
	3RT10 55	--	100	100	98	90	250	160	125	125
	3RT10 56	--	--	--	100	100	250	160	125	125

1) Note the operational voltage.

2) Assignment and short-circuit protective devices according to IEC 60947-4-1.

3) Voltage tolerance +5 %.

SIMOCODE 3UF Motor Management and Control Devices

3UF18 current transformers
for overload protection

Overload relay	Contactors	Rated operational current I_e AC-3 in A with 400 V and Class ...					Type of coordination 1 ²⁾	Type of coordination 2 ²⁾		
		5 and 10	15	20	25	30		Fuse links in A ¹⁾		British Standards fuses BS 88
						LV HRC, type 3NA DIAZED, type 5SB NEOZED, type 5SE gL/gG	LV HRC, type 3NA DIAZED, type 5SB NEOZED, type 5SE gL/gG	LV HRC, type 3ND aM		
Operating range 32 ... 130 A										
3UF18 50-3AA00	3RT10 44	65	56	49	45	41.7	250	125	--	--
	3RT10 45	80	61	53	47	45	250	160	--	--
	3RT10 46	95	69	59	53	50	250	160	--	--
	3RT10 54	115	93	82	75	69	315	224	160	160
	3RT10 55	130	122	107	98	90	315	224	160	160
	3RT10 56	--	130	130	120	111	315	224	160	160
	3RT10 64	--	--	--	130	130	315	224	160	160
	Operating range 50 ... 200 A									
3UF18 52-3BA00	3RT10 54	115	93	82	75	69	355	224	160	200
	3RT10 55	150	122	107	98	90	355	224	160	200
	3RT10 56	185	150	131	120	111	355	224	160	200
	3RT10 64	200	182	160	146	135	355	224	160	200
	3RT10 65	--	200	188	172	159	355	224	160	200
	3RT10 66	--	--	200	195	180	355	224	160	200
	3RT10 75	--	--	--	200	200	355	224	160	200
Operating range 63 ... 250 A										
3UF18 54-3CA00	3RT10 56	185	150	131	120	111	355	250	160	200
	3RT10 64	225	182	160	146	135	400	250	250	355
	3RT10 65	250	215	188	172	159	500	400	315	355
	3RT10 66	--	243	213	195	180	500	400	315	355
	3RT10 75	--	250	250	250	240	500	400	400	355
	3RT10 76	--	--	--	--	250	500	400	400	355
Operating range 100 ... 400 A										
3UF18 56-3DA00	3RT10 65	265	215	188	172	159	500	400	315	400
	3RT10 66	300	243	213	195	180	500	400	315	400
	3RT10 75	400	324	284	260	240	630	500	400	450
	3RT10 76	--	400	355	325	300	630	500	500	450
	3TF68	--	--	400	400	400	800	500	630	450
Operating range 125 ... 500 A										
3UF18 57-3EA00	3RT10 66	300	243	213	195	180	500	400	315	400
	3RT10 75	400	324	284	260	240	800	500	400	450
	3RT10 76	500	405	355	325	300	800	500	500	450
	3TF68	--	500	500	479	441	800	500	630	450
	3TF69	--	--	--	500	500	800	500	630	450
	Operating range 160 ... 630 A									
3UF18 68-3FA00	3RT10 75	400	324	284	260	240	800	500	400	450
	3RT10 76	500	405	355	325	300	800	500	500	450
	3TF68	630	630	536	479	441	1000	500	630	450
	3TF69	--	--	--	531	500	1000	500	630	450
Operating range 200 ... 820 A										
3UF18 69-3GA00	3TF68	630	630	536	479	441	1000	500	630	450
	3TF69	820	662	572	531	500	1000	500	630	450

1) Note the operational voltage.

2) Assignment and short-circuit protective devices according to IEC 60947-4-1.

Dimensional drawings

3UF18 43 current transformer

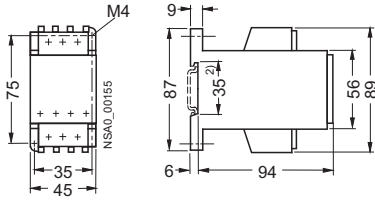

3UF18 45 current transformer

for stand-alone installation:

for screw and snap-on mounting onto TH 35 standard mounting rails according to EN 60715

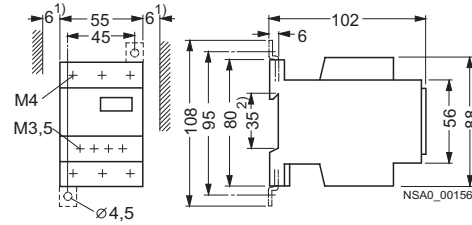

- 1) Clearance to grounded components.
- 2) Snap-on mounting onto standard mounting rails EN 60715-35 x 7.5 or EN 60715-35 x 15.

3UF18 47 to 3UF18 52 current transformers

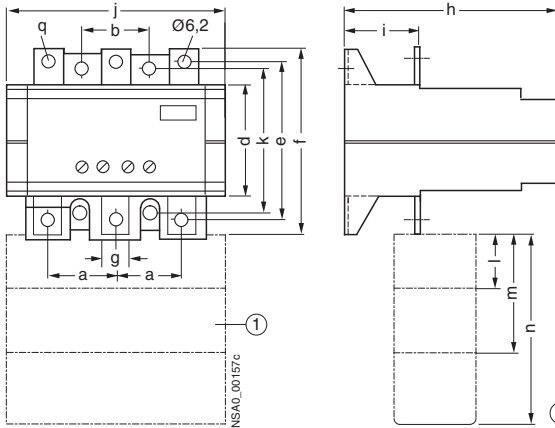

① Additional cover, can be shortened

Transformers	Contactors	a	b	d	e	f	g	h	i	j	k	l	m	n	q
3UF1 847	3RT1 044	26,5	25	82	111	122	10,5	90	46	90	105	35	62	89	Ø 6,2
3UF1 848	3RT1 045 3RT1 046	26,5	25	82	111	122	10,5	90	46	90	105	35	62	89	Ø 6,2
3UF1 850		37	37,5	71,5	99	114	15	110	41	120	95	33	67	98	Ø 6,6
3UF1 852		42	37,5	71,5	102	122	20	110	42	120	95	33	67	98	Ø 9

3UF18 54 to 3UF18 57 current transformers

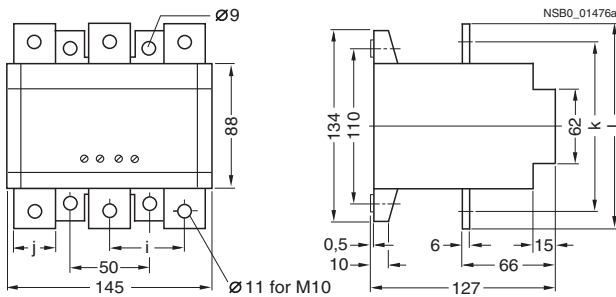

Transformers	i	j	k	l
3UF18 54	48	25	134	159
3UF18 56	48	25	134	159
3UF18 57	52	30	133	163

SIMOCODE 3UF Motor Management and Control Devices

3UF18 current transformers for overload protection

3UF18 68-3FA00, 3UF18 68-3GA00 current transformers
for 3TF68 contactors

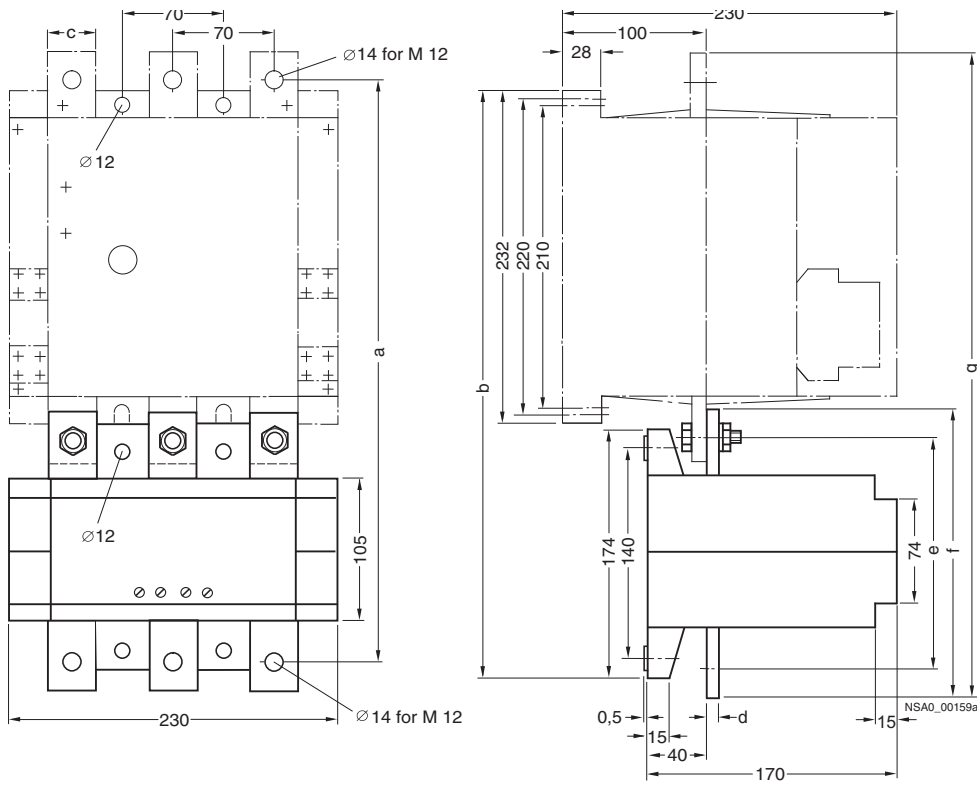

Transformers	Contactors	a	b	c	d	e	f	g
3UF18 68-3FA00	3TF68	390	398	30	5	145	175	420
3UF18 68-3GA00	3TF68	410	408	40	8	155	195	450

Overview



- The compact, user-friendly, and low-cost solution for simple control tasks
- Compact, user-friendly, can be used universally without accessories
- All in one: the display and operator panel are integrated
- 4-line LOGO! TD text display can be connected directly to all LOGO! basic versions
- 39 different functions can be linked at a press of a button or with PC software; up to 200 times in total
- Functions can be changed simply using buttons; no complicated rewiring

Catalog ST 70:

Information on LOGO! can also be found in the catalog ST 70:

<http://www.siemens.com/automation/salesmaterial-as/catalog/en/st70k1ad.pdf>

Design

The LOGO! modular design is available in different versions for different supply voltages (12 V DC, 24 V DC, 24 V AC, 115/230 V DC, 115/230 V AC):

- Basic versions with operator control and display panels
- Low-cost pure versions without operator control and display panels
- 4-line LOGO! TD text display can be connected directly to all LOGO! basic versions, degree of protection IP65, including connection cable

The LOGO! versions have the following distinguishing characteristics:

- R: relay output
- C: clock/time switch
- o: without display

LOGO! is simple:

- Keypad and display field in one unit; no other tools are required
- Non-volatile storage of switching program and setpoints (e. g. times) in integrated EEPROM

LOGO! is space-saving:

- e. g. LOGO! 230RC: 72 x 90 x 55 mm (W x H x D)
- Fitted mounting in the distribution box (same mounting dimensions as the RCCB)

LOGO! offers maximum flexibility and is universal:

- Expandability:
Depending on the application, additional expansion modules can be connected

LOGO! is communication-capable:

- Optional communication modules support connection to AS-Interface and instabus EIB networks

Function

LOGO! is simple:

- 39 functions:
Integrated basic functions (e. g. AND, OR) and special functions (e. g. timers, counters, latching relays, PI controllers) of the electronics
- Program generation simply by combining stored functions at the press of a button or PC software
- Easy-to-use and simple duplication of the switching program with an optional program module
- LOGO! offers maximum flexibility and is universal:
- Easy modification by reconnecting the functions at a press of a button; no need for time-consuming rewiring
- Optional operation from the PC:
For creating, simulating, online testing and archiving the switching program on the PC, including documentation facility

LOGO! Logic Modules

LOGO! Modular basic versions

Overview



- The space-saving basic versions
- Interface for connecting expansion modules, max. 24 digital inputs, 16 digital outputs, 8 analog inputs and 2 analog outputs can be addressed
- Interface for direct connection of the new LOGO! TD text display

Design

- Relay outputs with up to 10 A output current (not LOGO! 24)
- Integrated display field with background illumination (4x12 characters)
- Integrated operator control panel
- Integrated EEPROM for storing switching program and set-points
- Optional program module
- Integrated clock with automatic summertime/wintertime changeover (not LOGO! 24)
- 8 digital inputs, 4 digital outputs
- 4 inputs as analog inputs for 12/24 V DC versions (0 ... 10 V); inputs can also be used as digital inputs
- 4 inputs for counting up to 5 kHz can be used (for DC versions only)
- Interface for connecting expansion modules, max. 24 digital inputs, 16 digital outputs, 8 analog inputs and 2 analog outputs can be addressed
- Interface for direct connection of the new LOGO! TD text displays

Function

- Integrated basic and special functions:
- Basic functions: AND, OR, NOT, NAND, NOR, XOR, positive/negative edge evaluation
- Special functions: ON delay, latching ON-delay, OFF-delay, pulse relay, latching relay, counter (forwards/backwards), time switch, interval time-delay relay, operating hours counter, threshold switch, asynchronous pulse encoder, twelve-month time switch, easy-to-use switch function, random generator, staircase lighting function according to DIN 18015-2, edge-triggered interval time-delay relay, combined ON/OFF-delay, analog comparator, analog threshold switch, analog delta threshold switch, analog watchdog, analog amplifier, text and variable display, shift register, softkey function, PI controller, ramp function, analog multiplexer, analog arithmetic function, PWM function
- 200 function blocks can be combined
- 24 flags (including start-up flag)
- Integrated retentivity
- Password protection

Optional function

- Additional know-how protection with the optional program module
- Additional 2-year buffer for the integrated real-time clock (not LOGO! 24) with the optional battery and memory module/battery module
- 4-line LOGO! TD text display can be connected directly to all LOGO! basic versions

Overview

- The cost-optimized basic versions
- Interface for connecting expansion modules, max. 24 digital inputs, 16 digital outputs, 8 analog inputs and 2 analog outputs can be addressed
- Interface for direct connection of the new LOGO! TD text display

Design

- Relay outputs with up to 10 A output current (not LOGO! 24o).
- Integrated EEPROM for storing switching program and set-points
- Optional program module
- Integrated clock with automatic summertime/wintertime changeover (not LOGO! 24o)
- 8 digital inputs, 4 digital outputs
- 4 inputs as analog inputs for 12/24 V DC versions (0 ... 10 V); inputs can also be used as digital inputs
- 4 inputs for counting up to 5 kHz can be used (for DC versions only)
- Interface for connecting expansion modules, max. 24 digital inputs, 16 digital outputs, 8 analog inputs and 2 analog outputs can be addressed
- Interface for direct connection of the new LOGO! TD text displays

Function

- Integrated basic and special functions:
 - Basic functions: AND, OR, NOT, NAND, NOR, XOR, positive/negative edge evaluation
 - Special functions: ON delay, latching ON-delay, OFF-delay, pulse relay, latching relay, counter (forwards/backwards), time switch, interval time-delay relay, operating hours counter, threshold switch, asynchronous pulse encoder, twelve-month time switch, easy-to-use switch function, random generator, staircase lighting function according to DIN 18015-2, edge-triggered interval time-delay relay, combined ON/OFF-delay, analog comparator, analog threshold switch, analog delta threshold switch, analog watchdog, analog amplifier, shift register, softkey function, PI controller, ramp function, analog multiplexer, analog arithmetic function, PWM function
- 200 function blocks can be combined
- 24 flags (including start-up flag)
- Integrated retentivity
- Password protection

Optional function

- Additional know-how protection with the optional program module
- Additional 2-year buffer for the integrated real-time clock with the optional battery and memory module/battery module
- 4-line LOGO! TD text display can be connected directly to all LOGO! basic versions

LOGO! Logic Modules

LOGO! Software

Overview

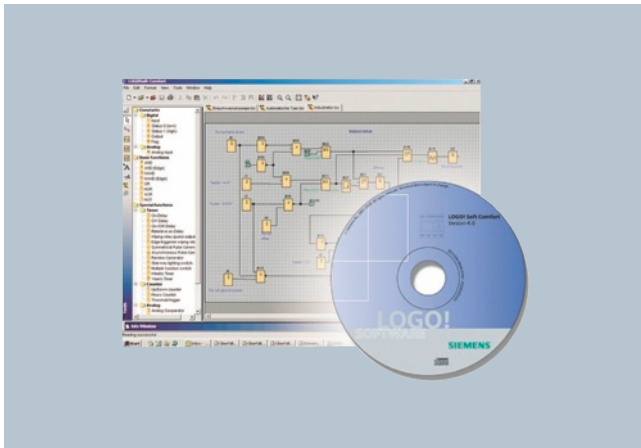

- The user-friendly software for switching program generation on the PC
- Switching program generation for function diagrams (FBD) or contact diagrams (LAD)
- Additional testing, simulation, online testing and archiving of the switching programs
- Professional documentation with the help of various comment and print functions

Design

The connection between LOGO! and the PC is established with the help of the LOGO! PC cable (serial or USB interface)

Minimum system requirements

Windows 98 SE, NT 4.0, ME, 2000, XP or Vista

- Pentium PC
- 90 Mbyte free on hard disk
- 64 Mbyte RAM
- SVGA graphics card with minimum 800x600 resolution (256 colors)

Mac OS X

- PowerMac G3, G4, G4 Cube, iMac, PowerBook G3, G4 or iBook

Linux (tested with Caldera OpenLinux 2.4)

- Runs on all Linux releases on which Java 2 SDK Version 1.3.1 runs
- Please consult your Linux release for hardware requirements

Function

- Control program generation with the programming languages FBD and LAD (switchable). How to place the functions on the drawing board by means of "Drag and Drop" is almost self-explanatory
- Comprehensive documentation functions: Various print options permit professional documentation
- Program simulation (offline): For preliminary testing of switching programs on the PC
- Program test (online): The current values of LOGO! are presented on screen, for FBD and LAD
- Analog modem communication for remote servicing of LOGO! with program UP/DOWN load and online test
- Comprehensive, context-sensitive online help functions

The following functions are available:

- Basic functions (AND, OR, NOT, NAND, NOR, XOR, positive edge evaluation, negative edge evaluation)
- ON-delay
- OFF-delay
- Current impulse relay
- Latching
- Latching ON-delay
- Operating hours counter
- Interval time-delay relay/pulse output mode
- Up/down counter
- Threshold switch
- Pulse encoder
- Twelve-month time switch
- Time switch
- ON/OFF-delay
- Random generator
- Edge-triggered interval time-delay relay
- Analog threshold switch
- Analog comparator
- Analog delta threshold switch
- Analog watchdog
- Analog amplifier
- Staircase lighting switch
- Easy-to-use switch
- Message texts
- Shift register
- Softkey
- PI controller
- Ramp function
- Analog multiplexer
- Analog arithmetic function
- PWM function

Function

3RP15 and 3RP20 function table

Function	Function chart	3RP20 timing relay and 3RP19 01 label set	3RP15 timing relay and 3RP19 01 label set	Identification letter	3RP15 1.	3RP15 25	3RP15 27	3RP15 3.	3RP15 40	3RP15 55	3RP15 7.
		3RP20 05-A	3RP20 25	3RP15 05-A	3RP19 01-0A						
1 CO contact											
With ON-delay				A							
OFF-delay with auxiliary voltage				B ¹⁾							
OFF-delay without auxiliary voltage <i>Observe minimum ON period for correct operation. For 3RP15 40-..W31: U_s 24 to 40 V AC/DC: 400 ms and U_s > 40 to 240 V AC/DC: 200 ms.</i>											
ON-delay and OFF-delay with auxiliary voltage (t = t _{on} = t _{off})				C ¹⁾							
Flashing, starting with interval (pulse/interval 1:1)				D							
Clock-pulse, starting with interval (dead time, pulse time, and time setting ranges each separately adjustable)											
Passing make contact				E							
Passing break contact with auxiliary voltage				F ¹⁾							
Pulse-forming with auxiliary voltage (pulse generation at the output does not depend on duration of energizing)				G ¹⁾							
Additive ON-delay with auxiliary voltage				H ¹⁾							
1 NO contact (semiconductor)											
ON-delay The two-wire timing relay is connected in series with the load. Timing begins after application of the exciting voltage. The semiconductor output then becomes conducting, and the load is under power.											

¹⁾ Note on function with start contact: A new control signal at terminal B, after the operating time has started, resets the operating time to zero.

This does not apply to G, G● and H, H●, which are not retriggerable.

■ Function is possible

3RP, 3RT19 Timing Relays

General data

Function	Function chart	3RP20 timing relay and 3RP19 01 label set	3RP15 timing relay and 3RP19 01 label set	Identification letter
		3RP20 05-B	3RP15 05-B	3RP15 05-R
		3RP20 25	3RP19 01-0B	3RP19 01-0A
				3RP15 1.
				3RP15 25
				3RP15 27
				3RP15 3.
				3RP15 40
				3RP15 55
				3RP15 60
				3RP15 7.
2 CO contacts				
With ON-delay		■	■	■
ON-delay and instantaneous contact		■	■	■
OFF-delay with auxiliary voltage		■	■	■
OFF-delay with auxiliary voltage and instantaneous contact		■	■	■
OFF-delay without auxiliary voltage				■
ON-delay and OFF-delay with auxiliary voltage ($t = t_{on} = t_{off}$)		■	■	■
ON-delay and OFF-delay with auxiliary voltage and instantaneous contact ($t = t_{on} = t_{off}$)		■	■	■
Flashing, starting with interval (pulse/interval 1:1)		■	■	■
Flashing, starting with interval (pulse/interval 1:1) and instantaneous contacts		■	■	■
Passing make contact		■	■	■
Passing make contact and instantaneous contact		■	■	■

For footnote see page 7/43.

■ Function is possible

Function	Function chart	3RP20 timing relay and 3RP19 01 label set	3RP15 timing relay and 3RP19 01 label set	Identification letter	3RP15 1.	3RP15 25	3RP15 27	3RP15 3.	3RP15 40	3RP15 55	3RP15 60	3RP15 7.
<p>Timing relay energized (hatched box)</p> <p>Contact closed (grey box)</p> <p>Contact open (white box)</p>												
<p>2 CO contacts</p>												
Passing break contact with auxiliary voltage		■	■	■	F ¹⁾							
Passing break contact with auxiliary voltage and instantaneous contact		■	■		F ¹⁾							
Pulse-forming with auxiliary voltage (pulse generation at the output does not depend on duration of energizing)		■	■	■	G ¹⁾							
Pulse-forming with auxiliary voltage and instantaneous contact (pulse generation at the output does not depend on duration of energizing)		■	■		G ¹⁾							
Additive ON-delay with auxiliary voltage				■	H ¹⁾							
Additive ON-delay with auxiliary voltage and instantaneous contact		■	■		H ¹⁾							
Wye-delta function		■	■		YΔ							
<p>2 NO contacts</p>												
Wye-delta function YΔ												■
<p>3 NO contacts</p>												
Wye-delta function with overtravel function ²⁾ (idling)												■

¹⁾ Note on function with start contact: A new control signal at terminal B, after the operating time has started, resets the operating time to zero. This does not apply to G, G[•] and H, H[•], which are not retriggerable.

²⁾ For function diagrams showing the various possibilities of operation of the 3RP15 60-1S.30, see page 7/45.

■ Function is possible

7

3RP, 3RT19 Timing Relays

General data

Function table 3RT19 16, 3RT19 26

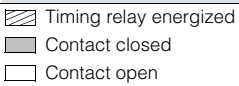
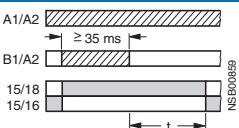
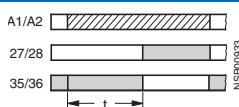
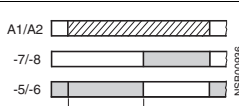
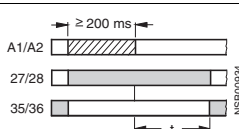
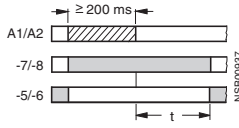
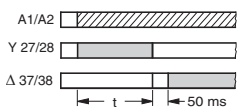
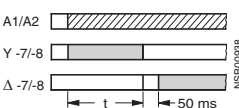
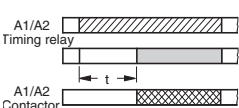
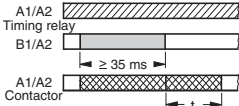

Function	Function chart	3RT19 16 timing relays						3RT19 26 timing relays			
		3RT19 16-2C	3RT19 16-2D	3RP19 16-2E	3RT19 16-2F	3RT19 16-2G	3RT19 16-2L	3RT19 26-2C	3RT19 26-2D	3RT19 26-2E	3RT19 16-2F
<p>  </p>											
1 CO contact											
OFF-delay with auxiliary voltage											
1 NO contact + 1 NC contact											
ON-delay (varistor integrated)											
With ON-delay											
OFF-delay without auxiliary voltage (varistor integrated)											
OFF-delay without auxiliary voltage											
2 NO contacts											
Wye-delta function (varistor integrated), 1 NO delayed, 1 NO instantaneous, dead time 50 ms											
Wye-delta function, 1 NO delayed, 1 NO instantaneous, dead time 50 ms											
1 NO contact (semiconductor)											
ON-delay Two-wire version (varistor integrated)											
OFF-delay with auxiliary voltage (varistor integrated)											

■ Function is possible

7

3RP15 function table

Possibilities of operation of the 3RP15 60-1S.30 timing relay

-  Timing relay energized
-  Contact closed
-  Contact open

Operation 1

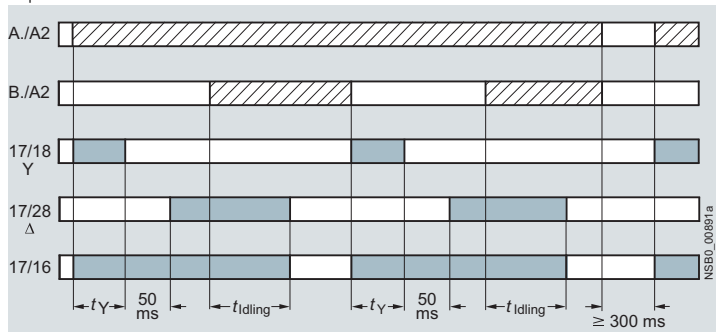

Operation 2

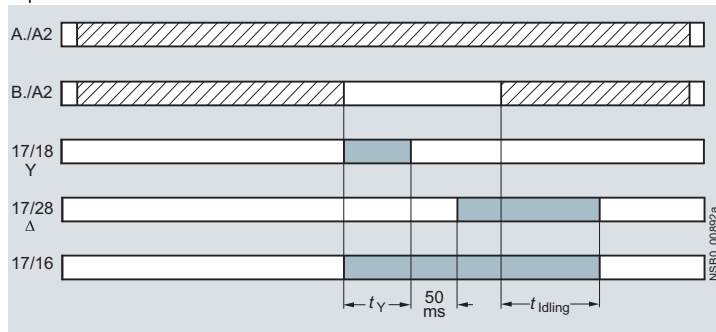

Operation 3

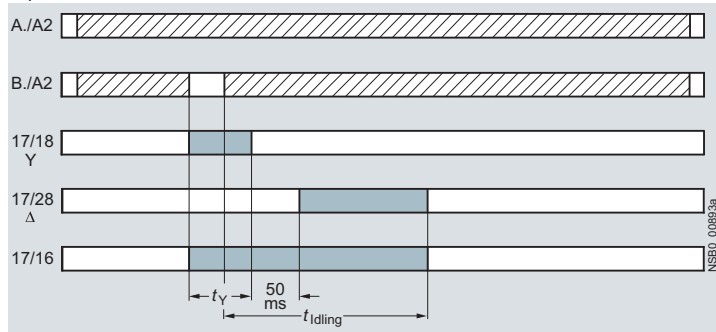

Operation 4

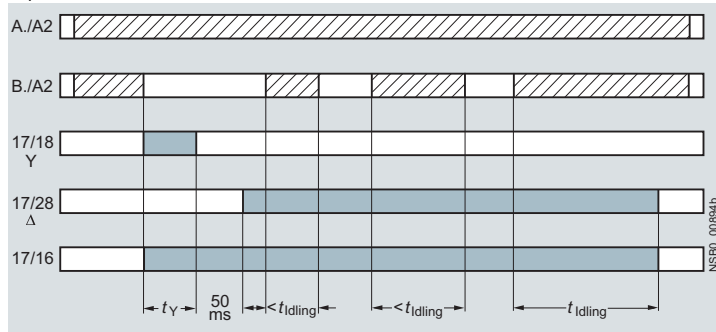

Note:

The following applies to all operations: The pressure switch controls the timing via B./A2.

- t_Y = Star time 1 ... 20 s
- t_{Idling} = Idling time (overtravel time) 30 ... 600 s

Operation 1:

Start contact B./A2 is open when supply voltage A./A2 is applied.

The supply voltage is applied to A./A2 and there is no control signal on B./A2. This starts the $\Upsilon\Delta$ timing. The idling time (coasting time) is started by applying a control signal to B./A2. When the set time t_{Idling} (30 ... 600 s) has elapsed, the output relays (17/16 and 17/28) are reset. If the control signal on B./A2 is switched off (minimum OFF period 270 ms), a new timing is started.

Comments:

Observe response time (dead time) of 400 ms on energizing supply voltage until contacts 17/18 and 17/16 close.

Operation 2:

Start contact B./A2 is closed when supply voltage A./A2 is applied.

If the control signal B./A2 is already present when the supply voltage A./A2 is applied, **no** timing is started. The timing is only started when the control signal B./A2 is switched off.

Operation 3:

Start contact B./A2 closes while star time is running.

If the control signal B./A2 is applied again during the star time, the idling time starts and the timing is terminated normally.

Operation 4:

Start contact B./A2 opens while delta time is running and is applied again.

If the control signal on B./A2 is applied and switched off again during the delta time, although the idling time has not yet elapsed, the idling time (coasting time) is reset to zero. If the control signal is re-applied to B./A2, the idling time is restarted.

Application example based on standard operation

(operation 1): For example, use of 3RP15 60 for compressor control

Frequent starting of compressors strains the network, the machine, and the increased costs for the operator. The new timing relay prevents frequent starting at times when there is high demand for compressed air. A special control circuit prevents the compressor from being switched off immediately when the required air pressure in the tank has been reached. Instead, the valve in the intake tube is closed and the compressor runs in "Idling" mode for a specific time which can be set from 30 ... 600 s.

If the pressure falls within this time, the motor does not have to be restarted again, but can return to nominal load operation from no-load operation.

If the pressure does not fall within this idling time, the motor is switched off.

The pressure switch controls the timing via B./A2.

The supply voltage is applied to A./A2 and the start contact B./A2 is open, i.e. there is no control signal on B./A2 when the supply voltage is applied. The pressure switch signals "too little pressure in system" and starts the timing by way of terminal B./A2. The compressor is started, enters $\Upsilon\Delta$ operation, and fills the pressure tank.

When the pressure switch signals "sufficient pressure", the control signal B./A2 is applied, the idling time (overtravel time) is started, and the compressor enters no-load operation for the set period of time from 30 ... 600 s. The compressor is then switched off. The compressor is only restarted if the pressure switch responds again (low pressure).

3RP, 3RT19 Timing Relays

3RP15 timing relays in industrial enclosure, 22.5 mm

Overview

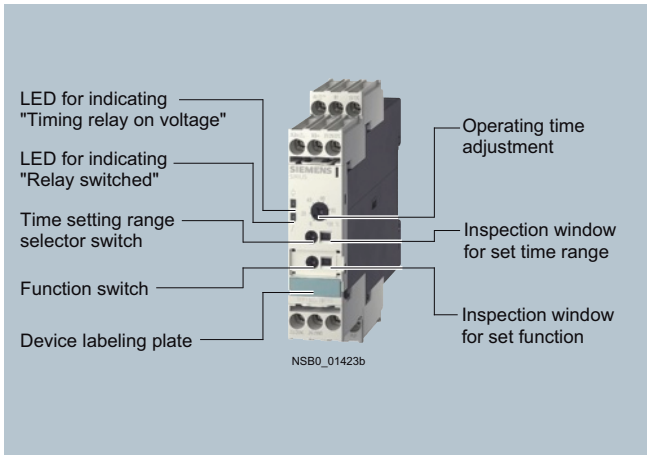

Standards

The timing relays comply with:

- EN 60947-5-1 (VDE 0660 Part 200) "Low-voltage switchgear and controlgear – Electromechanical control circuit devices"
- EN 61812-1 (VDE 0435 Part 2021) "Specified time relays for industrial use"
- EN 60721-3-3 "Environmental conditions"
- EN 61000-6-2 and EN 61000-6-4 "Electromagnetic compatibility"

Accessories



Push-in lugs for screw fixing



Sealable cover

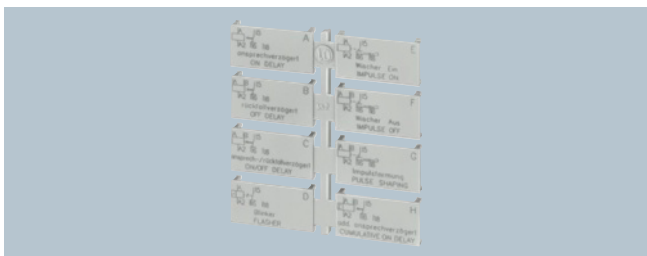

Label set for marking the multifunction relay

Function

- Changes to the time setting ranges and the functions must be carried out in the de-energized state.
- Start input B1 or B3 must only be triggered when the control supply voltage is applied.
- The same potential must be applied to A1 and B1 or A3 and B3. With two-voltage version, only one voltage range must be connected.
- The activation of loads parallel to the start input is not permissible when using AC control supply voltage (see diagrams).
- Surge suppression is integrated in the timing relay. This prevents the generation of voltage peaks on the control supply voltage when the relay is switched on and off. No additional damping measures are necessary.
- 3RP15 05-.R must not be operated next to heat sources > 60 °C.
- For 3RP15 40-..W31:
For correct operation, observe minimum ON period at 24 to 40 V AC/DC: 400 ms and at 40 to 240 V AC/DC: 200 ms.
The timing relay has only one LED which indicates that the control supply voltage is connected. The switch position of the relay is not indicated.
Setting of output contacts in as-supplied state not defined (bistable relay). Application of the control supply voltage once results in contact changeover to the correct setting.

Timing relay with multifunction

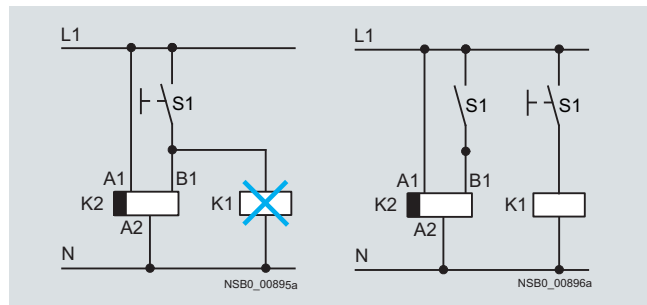

The functions can be adjusted by means of rotary switches. Insert labels can be used to adjust different functions of the 3RP15 05 timing relay clearly and unmistakably. The corresponding labels can be ordered as an accessory. The same potential must be applied to terminals A. and B.

Parallel load on start input



7

Technical specifications

Type		3RP15 05	3RP15 11	3RP15 40	3RP15 60	3RP15 74	3RP15 27
		3RP15 31	3RP15 12			3RP15 76	
		3RP15 32	3RP15 13				
		3RP15 33	3RP15 25				
			3RP15 55				
Rated insulation voltage Degree of pollution 3 Overvoltage category III	V AC	300; 500 for 3RP15 05-1BT10					
Operating range at excitation¹⁾		0.85 ... 1.1 x U_N with AC network frequency 50/60 Hz 0.8 ... 1.25 x U_N at 24 V DC 0.95 ... 1.05 times the rated frequency					
Rated power Power consumption at 230 V AC, 50 Hz	W VA	2 6		2 ²⁾	6		1 1
Rated operational current I_e • AC-140, DC-13 • AC-15 at 24 ... 400 V, 50 Hz • DC-13 at - 24 V - 125 V - 250 V	A A A A A A	-- 3 ³⁾ 1 0.2 0.1					0.01 ... 0.6 -- -- -- --
Conventional thermal current I_{th}	A	5					--
DIASED protection⁴⁾ gL/gG operational class	A	4					--
Switching frequency • When loaded with I_e 230 V AC • When loaded with 3RT10 16 contactor, 230 V AC	1/h 1/h	2500 5000					5000
Recovery time	ms	150	--	--	300	150	50
Minimum ON period	ms	35 ⁵⁾	--	200 ⁶⁾	--		
Residual current With non-conducting output	mA	--					5
Voltage drop With conducting output	VA	--					3.5
Short-time loading capacity	A	--					10 (up to 10 ms)
Setting accuracy With reference to upper limit of scale	%	Typical ± 5					
Repeat accuracy	%	$\leq \pm 1$					
Mechanical endurance	Operating cycles	30 x 10 ⁶					100 x 10 ⁶
Permissible ambient temperature	During operation During storage	°C °C	-25 ... +60 -40 ... +85				
Degree of protection acc. to EN 60529		IP40 cover, IP20 terminals					
Connection type		 Screw terminals					
• Terminal screw • Solid • Finely stranded with end sleeve • AWG cables, solid or stranded • Tightening torque	mm ² mm ² AWG Nm	M 3 (standard screwdriver, size 2 and Pozidriv 2) 1 x (0.5 ... 4)/2 x (0.5 ... 2.5) 1 x (0.5 ... 2.5)/2 x (0.5 ... 1.5) 2 x (20 ... 14) 0.8 ... 1.2					
Connection type		 Spring-type terminals					
• Solid • Finely stranded, with end sleeves acc. to DIN 46228 • Finely stranded • AWG cables, solid or stranded	mm ² mm ² mm ² AWG	2 x (0.25 ... 1.5) 2 x (0.25 ... 1.5) 2 x (0.25 ... 1.5) 2 x (24 ... 16)					
Permissible		Any					
Shock resistance acc. to IEC 60068-2-27 for half-sine shock type	g/ms	15/11					
Vibration resistance acc. to IEC 60068-2-6		10 ... 55 Hz: 0.35 mm					
Electromagnetic compatibility (EMC) acc. to basic specification		EN 61000-6-2/EN 61000-6-4					

1) If nothing else is stated.

2) Inrush current after 100 ms < 1 A. Observe for actuation with semiconductor output and internal current limit.

3) For 3RP15 05-.R: NC contact -> $I_e = 1$ A.4) $I_k \geq 1$ kA, weld-free according to IEC 60947-5-1.

5) Minimum ON period with 3RP15 05-.BW30, 150 ms, until instantaneous contact has switched.

6) For correct operation, observe minimum ON period. With 3RP15 40-..W31 at U_N 24 ... 40 V AC/DC: 400 ms, 40 ... 240 V AC/DC: 200 ms.

3RP, 3RT19 Timing Relays

3RP15 timing relays in industrial enclosure, 22.5 mm

Dimensional drawings

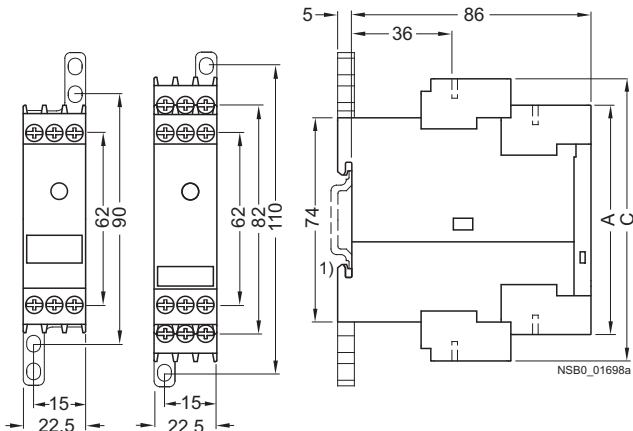

Type	3RP15 1	3RP15 05
	3RP15 25-.A	3RP15 25-.B
	3RP15 27	3RP15 3
	3RP15 40-A	3RP15 40-.B
	3RP15 55	3RP15 60
	3RP15 7	
	A	C

Removable terminal

Screw-type terminal	83	102
Spring-loaded terminal	84	103

1) For standard mounting rail according to EN 60715.

Schematics

3RP15 internal circuit diagrams (terminal designation to DIN 46199, Part 5)

3RP15 05-.A
3RP15 1.
3RP15 25-.A

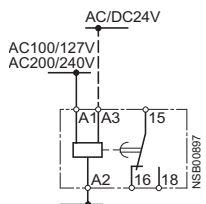

With ON-delay

3RP15 05-.A
3RP15 3-.A

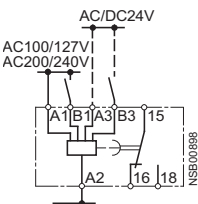

OFF-delay with auxiliary voltage

3RP15 05-.A

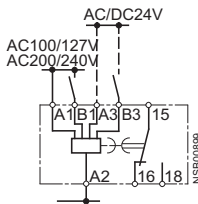

ON-delay and OFF-delay with auxiliary voltage

3RP15 05-.A

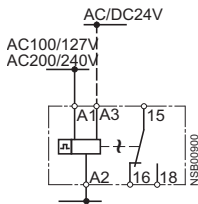

Flashing

3RP15 05-.A

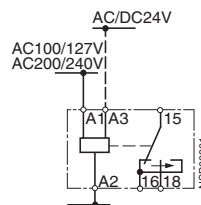

Passing make contact

3RP15 05-.A

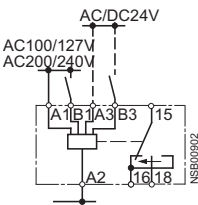

Passing break contact with auxiliary voltage

3RP15 05-.A

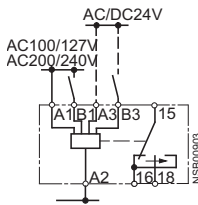

Pulse-forming with auxiliary voltage

3RP15 05-.A

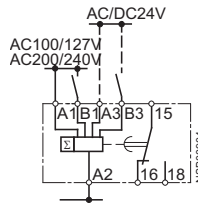

Additive ON-delay with auxiliary voltage

3RP, 3RT19 Timing Relays

3RP15 timing relays in industrial enclosure, 22.5 mm

3RP15 27

$U = 24 \dots 66 \text{ V AC/DC}$
 $90 \dots 240 \text{ V AC/DC}$

AC/DC 24-66V
 AC/DC 90-240V

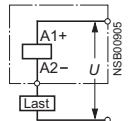

ON-delay,
two-wire version

3RP15 40-A

AC/DC24V
 AC/DC100...127V
 AC/DC200...240V
 AC/DC24...240V

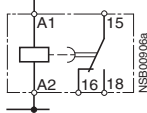

OFF-delay
without auxiliary voltage

3RP15 55

AC/DC24V
 AC/DC42V...48V
 AC/DC60V
 AC100/127V
 AC200/240V

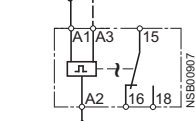

Clock-pulse relay

3RP15 05-AW30

AC/DC24...240V

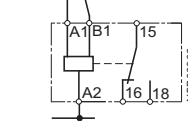

Multifunction relay
(same functions as 3RP15 05-1A)

3RP15 05-B, 3RP15 25-1B

AC/DC24V
 AC100/127V
 AC200/240V

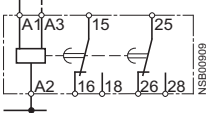

ON-delay, 3RP15 25-1B
 also for 42 ... 48/60 V AC/DC
 (see page 7/50 3RP15 25-1BR30)

3RP15 05-B

AC/DC24V
 AC100/127V
 AC200/240V

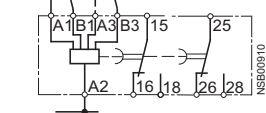

OFF-delay with auxiliary voltage

3RP15 05-B

AC/DC24V
 AC100/127V
 AC200/240V

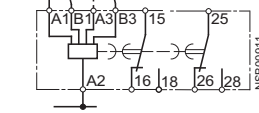

ON-delay and OFF-delay
with auxiliary voltage

3RP15 05-B

AC/DC24V
 AC100/127V
 AC200/240V

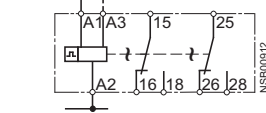

Flashing

3RP15 05-B

AC/DC24V
 AC100/127V
 AC200/240V

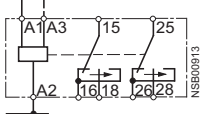

Passing make contact

3RP15 05-B

AC/DC24V
 AC100/127V
 AC200/240V

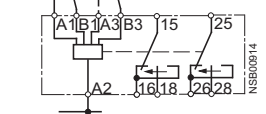

Passing break contact
with auxiliary voltage

3RP15 05-B

AC/DC24V
 AC100/127V
 AC200/240V

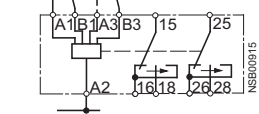

Pulse-forming with auxiliary voltage

3RP15 05-B

AC/DC24V
 AC100/127V
 AC200/240V

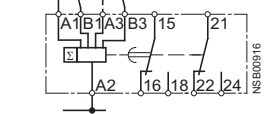

Additive ON-delay with
auxiliary voltage and instantaneous
contact

3RP15 05-B

AC/DC24V
 AC100/127V
 AC200/240V

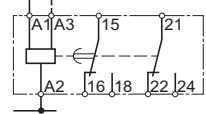

ON-delay and instantaneous
contact

3RP15 05-B

AC/DC24V
 AC100/127V
 AC200/240V

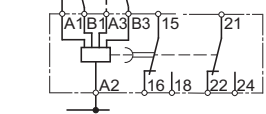

OFF-delay with auxiliary voltage
and instantaneous contact

3RP15 05-B

AC/DC24V
 AC100/127V
 AC200/240V

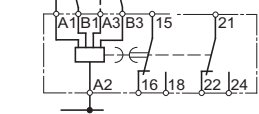

ON-delay and OFF-delay with aux-
iliary voltage and instantaneous
contact

3RP15 05-B

AC/DC24V
 AC100/127V
 AC200/240V

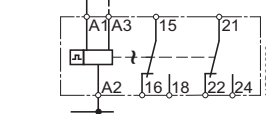

Flashing and instantaneous contact

3RP15 05-B

AC/DC24V
 AC100/127V
 AC200/240V

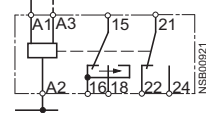

Passing make contact
and instantaneous contact

3RP15 05-B

AC/DC24V
 AC100/127V
 AC200/240V

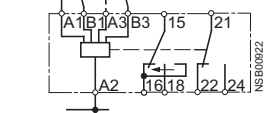

Passing break contact with aux-
iliary voltage and instantaneous
contact

3RP15 05-B

AC/DC24V
 AC100/127V
 AC200/240V

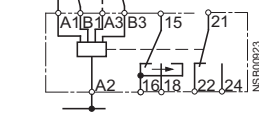

Pulse-forming with auxiliary voltage
and instantaneous contact

3RP15 05-B

AC/DC24V
 AC100/127V
 AC200/240V

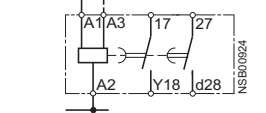

Wye-delta function

3RP, 3RT19 Timing Relays

3RP15 timing relays in industrial enclosure, 22.5 mm

3RP15 05-.BW30/-1BT20/-RW30

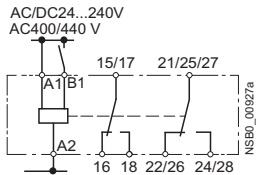

Multifunction relay
(for functions see function table)

3RP15 25-.BR30

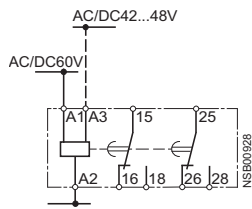

With ON-delay

3RP15 25-.BW30

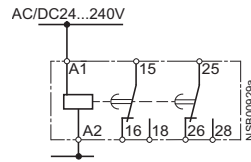

With ON-delay

3RP15 40-.B

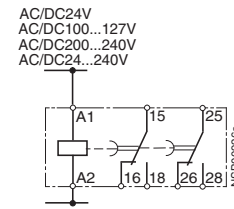

OFF-delay without auxiliary voltage

3RP15 60-.S

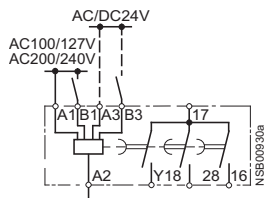

Wye-delta timing relay with overtravel function (idling)

3RP15 7-.M20

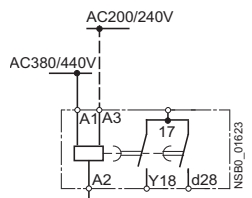

Wye-delta timing relay

3RP15 74, 3RP15 76

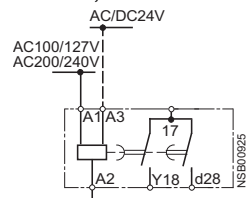

Wye-delta timing relay

Position of the terminals

3RP15 05-.A

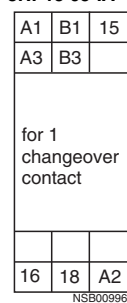

3RP15 05-.AA40



3RP15 05-.AW



3RP15 05-.BP/-BQ



3RP15 05-.BW



3RP15 05-1BT



3RP15 05-.RW



3RP15 1.



3RP15 25-1A. or -1B. 1)

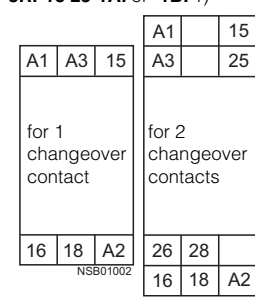

3RP15 27

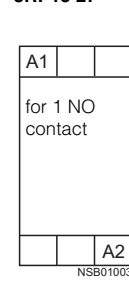

3RP15 3.

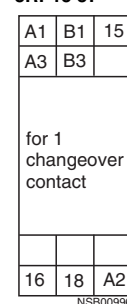

3RP15 40

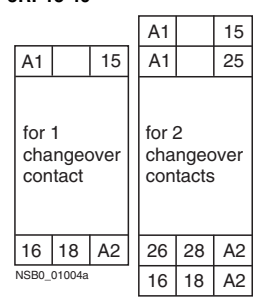

3RP15 55



3RP15 60

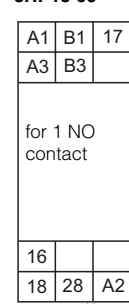

3RP15 7.



Note: All the diagrams show the view onto the terminals.

1) Depending on the version.

3RP, 3RT19 Timing Relays

3RP15 timing relays in industrial enclosure, 22.5 mm

3RP15 circuit diagrams

Control circuits (example circuits) with 3RP15 74 and 3RP15 76 wye-delta timing relays

For momentary-contact operation

Size S00 to S3

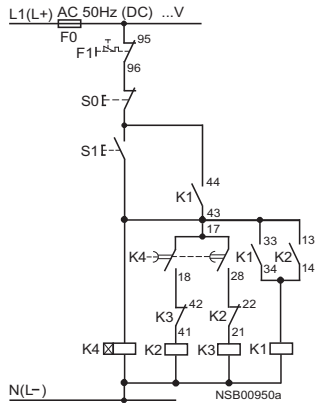

For maintained-contact operation

Size S00 to S3

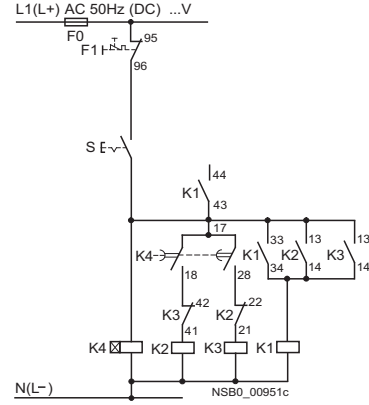

Control circuit (example circuit) with 3RP15 60 wye-delta timing relays

Legend:

- S0 Button "OFF"
- S1 Button "ON"
- S Maintained-contact button
- K1 Line contactor
- K2 Star contactor
- K3 Delta contactor
- K4 Timer or timing relay
- F0 Fuse
- F1 Overload relay
- P1 Pressure switch

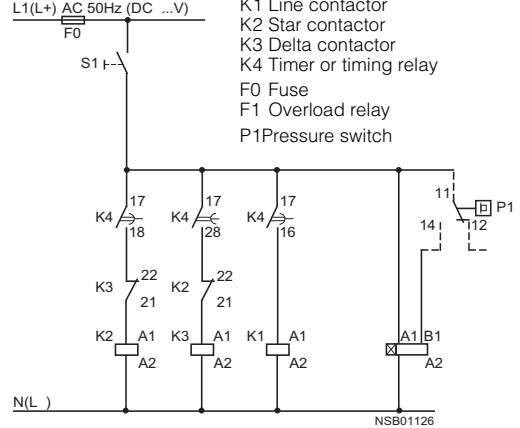

Note:

The contact element 17/18 is only closed in the wye stage; the contact element is open in the delta stage as well as in the de-energized state.

3RP, 3RT19 Timing Relays

3RP20 timing relays, 45 mm

Overview

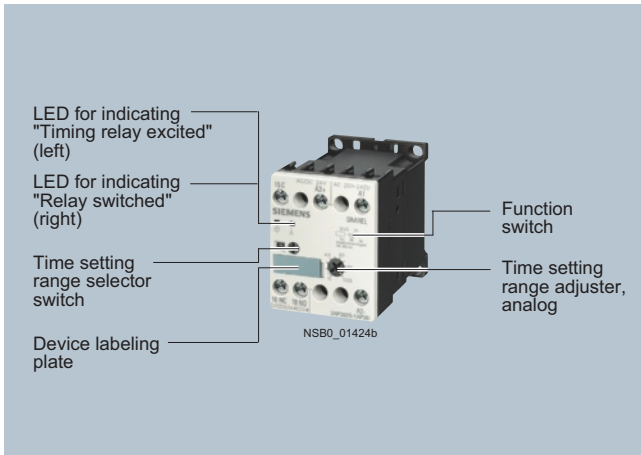

Standards

The timing relays comply with:

- EN 60947-5-1 (VDE 0660 Part 200)
"Low-voltage switchgear and controlgear – Electromechanical control circuit devices"
- EN 61812-1 (VDE 0435 Part 2021)
"Specified time relays for industrial use"
- EN 60721-3-3 "Environmental conditions"
- EN 61000-6-2 and EN 61000-6-4
"Electromagnetic compatibility"
- EN 61140 "Protective separation"

Accessories

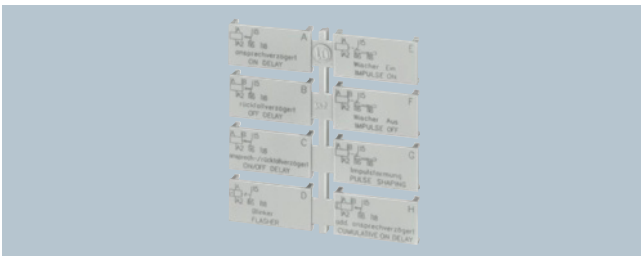

Label set for marking the multifunction relay

Function

- Changes to the time setting ranges and the functions must be carried out in the de-energized state.
- Start input B1 or B3 must only be triggered when the control supply voltage is applied.
- The same potential must be applied to A1 and B1 or A3 and B3. With two-voltage version, only one voltage range must be connected.
- The activation of loads parallel to the start input is not permissible when using AC control supply (see diagrams).
- Surge suppression is integrated in the timing relay. This prevents the generation of voltage peaks on the control supply voltage when the relay is switched on and off. No additional damping measures are necessary.

Timing relay with multifunction

The functions can be adjusted by means of rotary switches. Insert labels can be used to adjust different functions of the 3RP20 05 timing relay clearly and unmistakably. The corresponding labels can be ordered as an accessory. The same potential must be applied to terminals A. and B.

3RP20 05 with one changeover contact

Corresponds to the functions of 3RP15 05-.A.



3RP20 05 with two changeover contacts

Corresponds to the functions of 3RP15 05-.B.

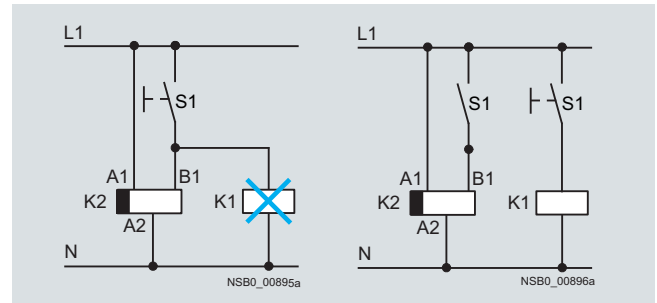
Parallel load on start input



Technical specifications

Type		3RP20 05 3RP20 25
Rated insulation voltage Degree of pollution 3 Overvoltage category III	V AC	300
Operating range at excitation¹⁾		0.85 ... 1.1 x U_s at AC; 0.8 ... 1.25 x U_s at DC; 0.95 ... 1.05 times rated frequency
Rated power Power consumption at 230 V AC, 50 Hz	W VA	1 4
Rated operational current I_e • AC-15, at 24 ... 400 V, 50 Hz • DC-13 at - 24 V - 125 V - 250 V	A A A A A	3 1 0.2 0.1
Conventional thermal current I_{th}	A	5
DIAZED protection²⁾ gL/gG operational class	A	4
Switching frequency • When loaded with I_e 230 V AC • When loaded with 3RT10 16 contactor, 230 V AC	1/h 1/h	2500 5000
Recovery time	ms	150
Minimum ON period	ms	35
Setting accuracy With reference to upper limit of scale	%	Typical ±5
Repeat accuracy	%	≤ ±1
Mechanical endurance Operating cycles		30 x 10 ⁶
Permissible ambient temperature During operation During storage	°C °C	-25 ... +60 -40 ... +85
Degree of protection acc. to EN 60529		IP40 cover, IP20 terminals
Connection type		 Screw terminals
• Terminal screw • Solid • Finely stranded with end sleeve • AWG cables, solid or stranded • Tightening torque	mm ² mm ² AWG Nm	M 3 (standard screwdriver, size 2 and Pozidriv 2) 1 x (0.5 ... 4)/2 x (0.5 ... 2.5) ³⁾ 1 x (0.5 ... 2.5)/2 x (0.5 ... 1.5) ³⁾ 2 x (20 ... 14) ³⁾ 0.8 ... 1.2
Connection type		 Spring-type terminals
• Solid • Finely stranded, with end sleeves acc. to DIN 46228 • Finely stranded • AWG cables, solid or stranded	mm ² mm ² mm ² AWG	2 x (0.25 ... 1.5) 2 x (0.25 ... 1.5) 2 x (0.25 ... 1.5) 2 x (24 ... 16)
Permissible		Any
Shock resistance acc. to IEC 60068 for half-sine shock type	g/ms	15/11
Vibration resistance acc. to IEC 60068-2-6		10 ... 55 Hz: 0.35 mm
Electromagnetic compatibility (EMC) acc. to basic specification		EN 61000-6-2/EN 61000-6-4

1) If nothing else is stated.

2) $I_k \geq 1$ kA, weld-free according to IEC 60947-5-1.

3) If two different conductor cross-sections are connected to one clamping point, both cross-sections must lie in the range specified. If identical cross-sections are used, this restriction does not apply.

3RP, 3RT19 Timing Relays

3RP20 timing relays, 45 mm

Dimensional drawings

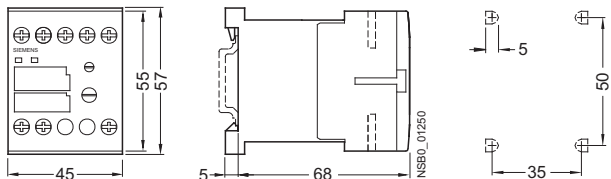

Schematics

3RP20 internal circuit diagrams
(terminal designation to DIN 46199, Part 5)

3RP20 05
3RP20 25

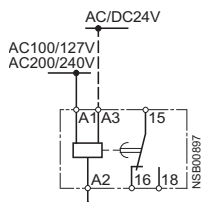

With ON-delay

3RP20 05

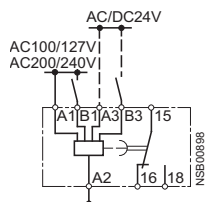

OFF-delay with auxiliary voltage

3RP20 05

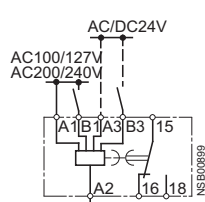

ON-delay and OFF-delay with auxiliary voltage

3RP20 05

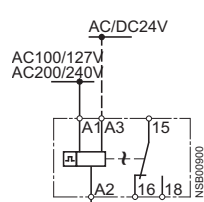

Flashing

3RP20 05

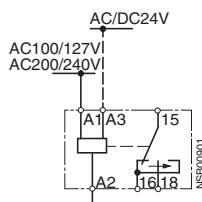

Passing make contact

3RP20 05

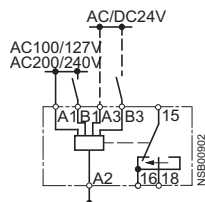

Passing break contact with auxiliary voltage

3RP20 05

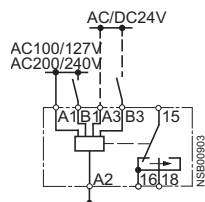

Pulse-forming with auxiliary voltage

Position of the terminals

3RP20 05-A

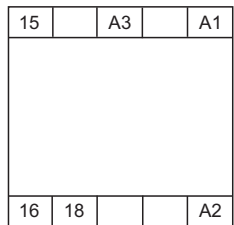

NSB0_01196a

3RP20 25-A

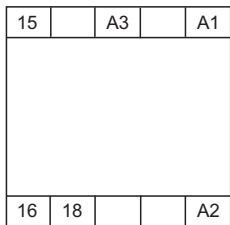

NSB0_01196a

3RP20 05-BW30

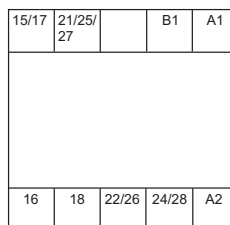

NSB0_01392

Note:

All the diagrams show the view onto the terminals.

Technical specifications

According to IEC 61812-1 (VDE 0435 Part 2021)

Contactors	Type	Solid-state time-delay blocks with semiconductor output		Solid-state time-delay auxiliary switch blocks			
		3RT19 .6-2C	3RT19 .6-2D	3RT19 .6-2L	3RT19 .6-2E	3RT19 .6-2F	3RT19 .6-2G
Rated insulation voltage U_i Degree of pollution 3 Overvoltage category III acc. to EN 60664-1		V AC	300				
Operating range of excitation			0.8 ... 1.1 x U_s , 0.95 ... 1.05 times rated frequency		0.85 ... 1.1 x U_s , 0.95 ... 1.05 times rated frequency		
Rated power Power consumption at 230 V AC, 50 Hz		W VA	1 1		2 4		
Rated operational currents I_e • AC-140, DC-13 • AC-15, 24 ... 400 V, 50 Hz • DC-13, 24 V • DC-13, 125 V • DC-13, 250 V		A	0.3 for 3RT19 16 0.5 for 3RT19 26 -- -- --		-- -- 3 1 0.2 0.1		
DIАЗED protection gL/gG operational class		A	--		4		
Switching frequency for load • With I_e 230 V AC • With 3RT10 16 contactor, 230 V AC		1/h 1/h	2500 2500		5000		
Recovery time		ms	50		150		
Minimum ON period		ms	35		35 (OFF-delay with auxiliary voltage)	200 (with OFF-delay)	
Residual current	Max.	mA	5		--		
Voltage drop With conducting output	Max.	VA	3.5		--		
Short-time loading capacity	Up to 10 ms	A	10		--		
Setting accuracy With reference to upper limit of scale		%	typ. ±15				
Repeat accuracy		%	typ. ≤ ±1				
Mechanical endurance		Oper- ating cycles	100 x 10 ⁶		10 x 10 ⁶		
Permissible ambient temperature • During operation • During storage		°C °C	-25 ... +60 -40 ... +80				
Degree of protection acc. to EN 60947-1, Appendix C • Cover • Terminals			IP40 IP20				
Connection type			 Screw terminals				
• Terminal screw • Solid • Finely stranded with end sleeve • AWG cables, solid or stranded • Tightening torque		mm ² mm ² AWG Nm	M 3 (standard screwdriver, size 2 and Pozidriv 2) 1 x (0.5 ... 4)/2 x (0.5 ... 2.5) 1 x (0.5 ... 2.5)/2 x (0.5 ... 1.5) 2 x (20 ... 14) 0.8 ... 1.2				
Permissible mounting positions			Any				
Shock resistance Half-sine acc. to IEC 60068-2-27		g/ms	15/11				
Vibration resistance acc. to IEC 60068-2-6			10 ... 55 Hz: 0.35 mm				
Electromagnetic compatibility (EMC) acc. to basic specification			EN 61000-6-2/EN 61000-6-4				
Overvoltage protection			Varistor integrated in timing relay		--		

3RP, 3RT19 Timing Relays

3RT19 16, 3RT19 26 timing relays for mounting onto contactors

Dimensional drawings

3RT19 16-2E, -2F, -2G, -2L
solid-state, time-delay auxiliary switch blocks
For size S00 contactors and contactor relays

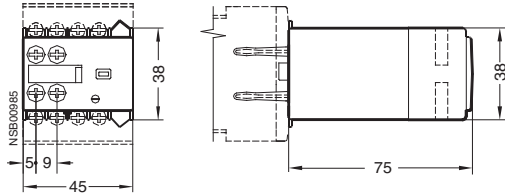

3RT19 16-2D
solid-state time-delay blocks, with OFF-delay
For mounting onto the front of size S00 contactors

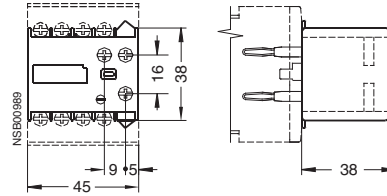

3RT19 26-2E, -2F, -2G
For size S0 to S3 contactors and contactor relays

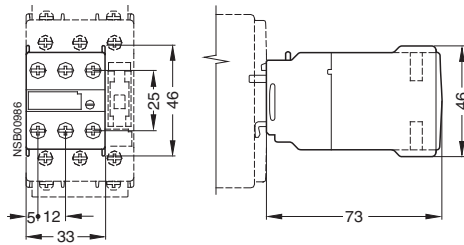

3RT19 26-2D
Mountable on top or bottom of the contactors for size S0 to S3

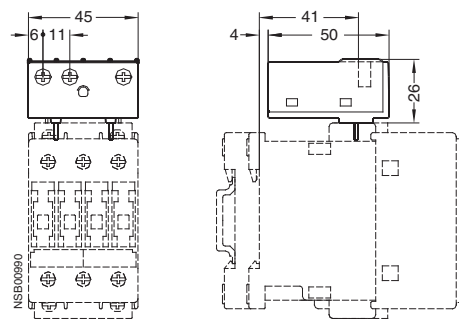

3RT19 16-2C
solid-state time-delay blocks, with ON-delay
For mounting onto the front of size S00 contactors

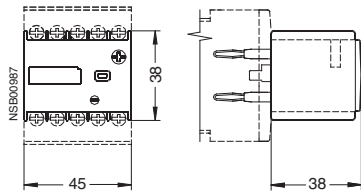

3RT19 26-2C
Mountable on top or bottom of the contactors for size S0 to S3

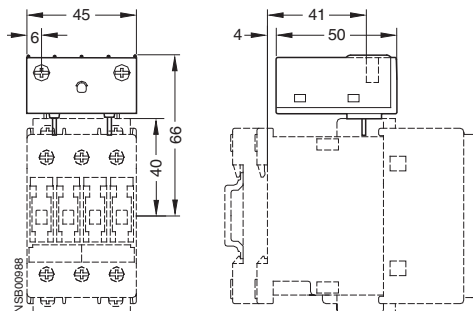

3RP, 3RT19 Timing Relays

3RT19 16, 3RT19 26 timing relays
for mounting onto contactors

Schematics

3RT19 circuit diagrams

Control circuits (example circuits)
with delayed 3RT19 .6-2G wye-delta auxiliary switch block

For momentary-contact operation

Size S00

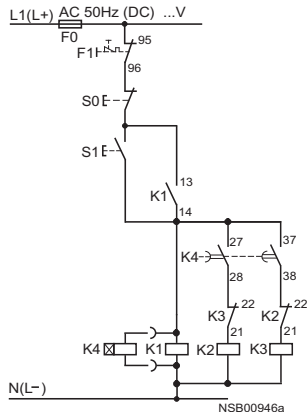

Sizes S0 to S3

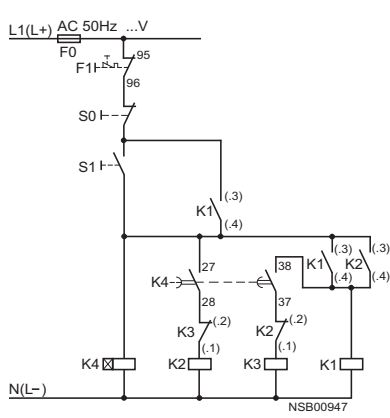

For maintained-contact operation

Size S00

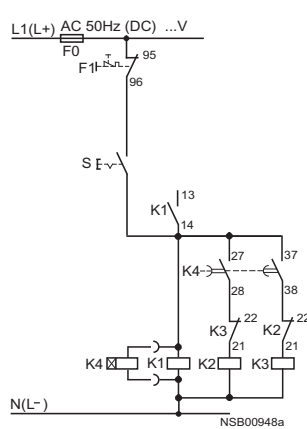

Sizes S0 to S3

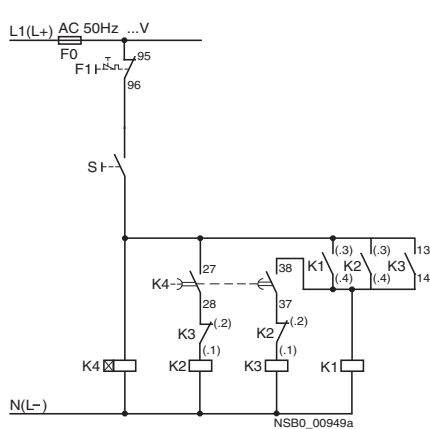

Legend:

- S0 "OFF" button
- S1 "ON" button
- S Maintained-contact switch

- K1 Line contactor
- K2 Star contactor
- K3 Delta contactor
- K4 Timer or timing relay

- F0 Fuse
- F1 Overload relay

Note:

The 27/28 contact element for the solid-state time-delay auxiliary switch block with wye-delta function is only closed on the wye stage; the contact element is open in the delta stage as well as in the de-energized state.

3RP, 3RT19 Timing Relays

3RT19 16, 3RT19 26 timing relays for mounting onto contactors

Solid-state timing relay blocks

For size S00 to S3 3RT10 contactors and 3RH11 contactor relays

3RT19 16-2C

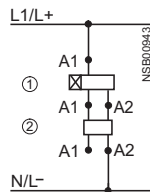

With ON-delay

3RT19 26-2C

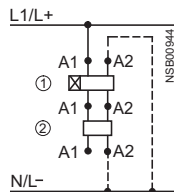

With ON-delay

3RT19 16-2D/3RT19 26-2D

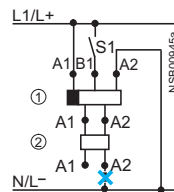

OFF-delay (with auxiliary voltage)

- ① Timing relay block
- ② Contactor
- Can be connected
- ✘ **Do not connect!**

3RT19 16-2E

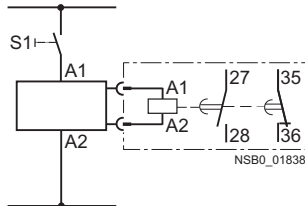

With ON-delay

3RT19 26-2E

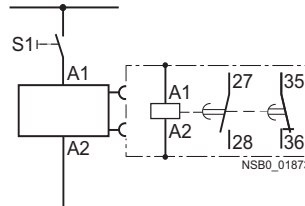

With ON-delay

3RT19 16-2F

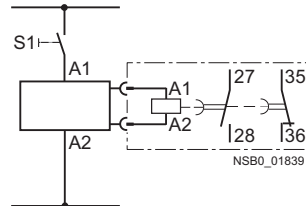

With OFF-delay (without auxiliary voltage)

3RT19 26-2F

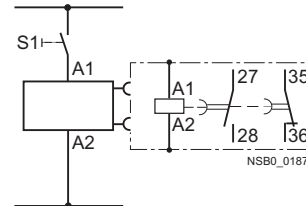

With OFF-delay (without auxiliary voltage)

3RT19 16-2G

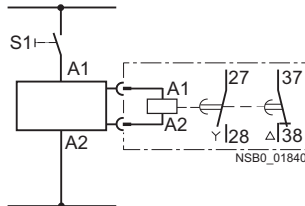

Wye-delta function

3RT19 26-2G

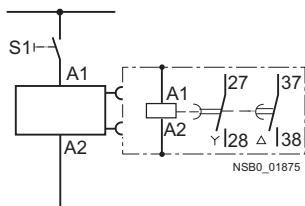

Wye-delta function

3RT19 16-2L

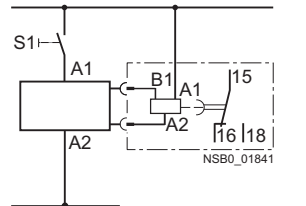

OFF-delay (with auxiliary voltage)

7

Overview



Solid-state line monitoring relays provide maximum protection for mobile machines and plants or for unstable networks. Network and voltage faults can be detected early and rectified before far greater damage ensues.

Depending on the version, the relays monitor phase sequence, phase failure with and without N conductor monitoring, phase unbalance, undervoltage or overvoltage.

Phase unbalance is evaluated as the difference between the greatest and the smallest phase voltage relative to the greatest phase voltage. Undervoltage or overvoltage exists when at least one phase voltage deviates by 20 % from the set rated system voltage or the directly set limit values are overshoot or undershoot. The rms value of the voltage is measured.

With the 3UG46 17 or 3UG46 18 relay, a wrong direction of rotation can also be corrected automatically.

Function

3UG45 11 monitoring relays

The 3UG45 11 phase sequenced relay monitors the phase sequence in a three-phase network. No adjustments are required for operation. The device has an internal power supply and works using the closed-circuit principle. If the phase sequence at the terminals L1-L2-L3 is correct, the output relay picks up after the delay time has elapsed and the LED is lit. If the phase sequence is wrong, the output relay remains in its rest position.

Note: When one phase fails, connected loads (motor windings, lamps, transformers, coils, etc.) create a feedback voltage at the terminal of the failed phase due to the network coupling. Because the 3UG45 11 relays are not resistant to voltage feedback, such a phase failure is not detected. Should this be required, then the 3UG45 12 monitoring relay must be used.

Correct phase sequence

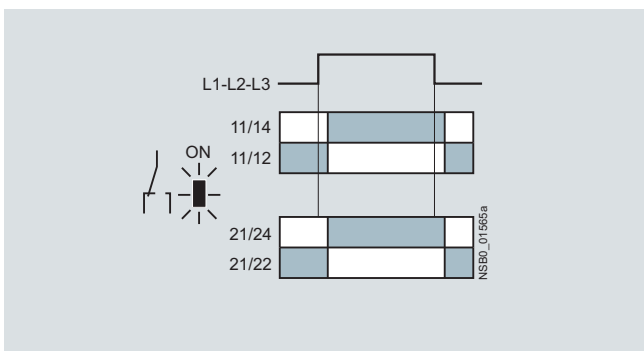

Wrong phase sequence

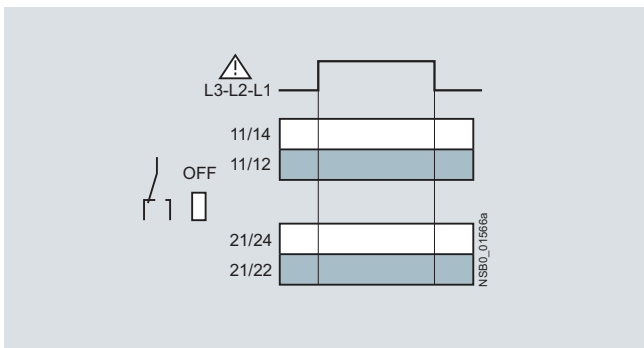

3UG45 12 monitoring relays

The 3UG45 12 line monitoring relay monitors three-phase networks with regard to phase sequence, phase failure and phase unbalance of 10 %. Thanks to a special measuring method, a phase failure is reliably detected in spite of the wide voltage range from 160 ... 690 V AC and feedback through the load of up to 90 %. The device has an internal power supply and works using the closed-circuit principle. No adjustments are required.

When the mains voltage is switched on, the green LED is lit. If the phase sequence at the terminals L1-L2-L3 is correct, the output relay picks up. If the phase sequence is wrong, the red LED flashes and the output relay remains in its rest position. If a phase fails, the red LED is permanently lit and the output relay drops.

Note: The red LED is a fault diagnostic indicator and does not show the current relay status. The 3UG45 12 monitoring relay is suitable for line frequencies of 50/60 Hz.

Phase failure

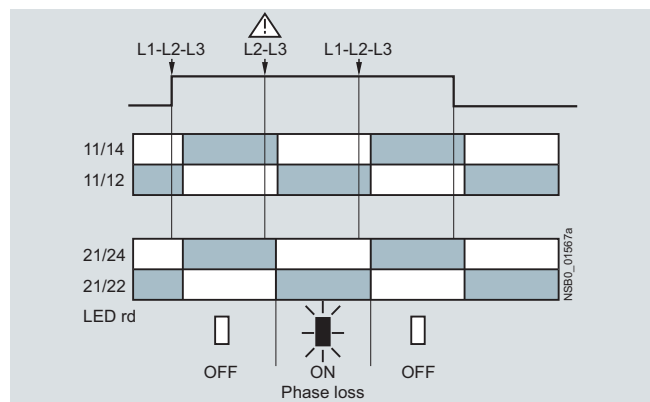

Wrong phase sequence

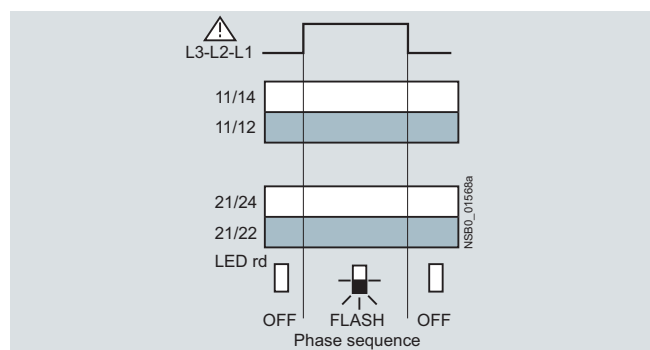

Monitoring Relays

3UG Monitoring Relays for Electrical and Additional Measurements

Line monitoring

3UG45 13 monitoring relays

The 3UG45 13 line monitoring relay monitors three-phase networks with regard to phase sequence, phase failure, phase unbalance and undervoltage of 20 %. The device has an internal power supply and works using the closed-circuit principle. The hysteresis is 5 %. The integrated response delay time is adjustable from 0 ... 20 s and responds to undervoltage. If the direction is incorrect, the device switches off immediately. Thanks to a special measuring method, a phase failure is reliably detected in spite of the wide voltage range from 160 ... 690 V AC and feedback up to 80 % through the load. When the mains voltage is switched on, the green LED is lit. If the phase sequence at the terminals L1-L2-L3 is correct, the output relay picks up. If the phase sequence is wrong, the red LED flashes and the output relay remains in its rest position. If a phase fails, the red LED is permanently lit and the output relay drops.

Note:

The red LED is a fault diagnostic indicator and does not show the current relay status. The 3UG45 13 monitoring relay is suitable for line frequencies of 50/60 Hz.

Phase failure and undervoltage

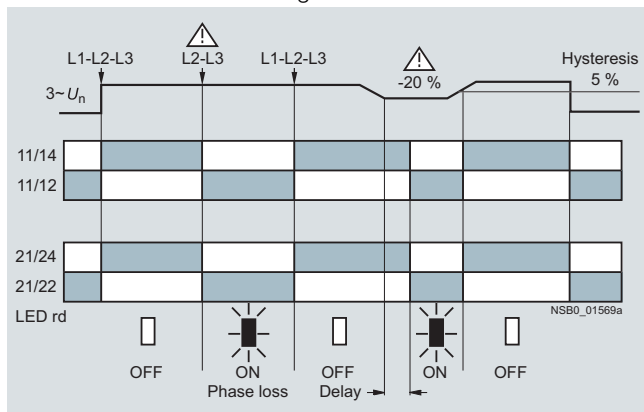

Wrong phase sequence

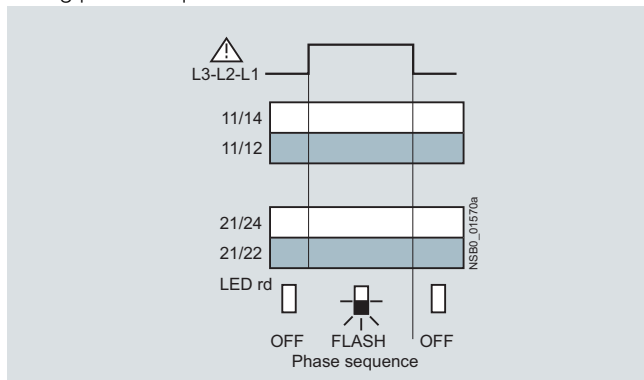

3UG46 14 monitoring relays

The 3UG46 14 line monitoring relay has a wide voltage range and an internal power supply. The device is equipped with a display and is parameterized using three buttons. It monitors three-phase networks with regard to phase unbalance from 5 ... 20 %, phase failure, undervoltage and phase sequence. The hysteresis is adjustable from 1 ... 20 V. In addition the device has a response delay and ON-delay from 0 ... 20 s in each case. The integrated response delay time responds to phase unbalance and undervoltage. If the direction is incorrect, the device switches off immediately. Thanks to a special measuring method, a phase failure is reliably detected in spite of the wide voltage range from 160 ... 690 V AC and feedback up to 80 % through the load.

The 3UG46 14 monitoring relay can be operated on the basis of either the open-circuit or closed-circuit principle and with manual or auto RESET.

With the closed-circuit principle selected

Wrong phase sequence

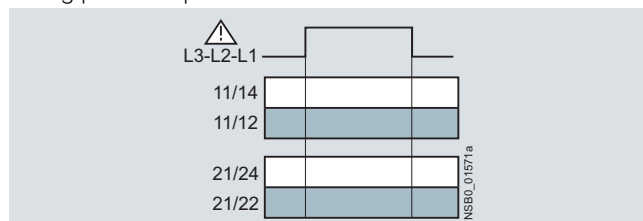

Phase failure

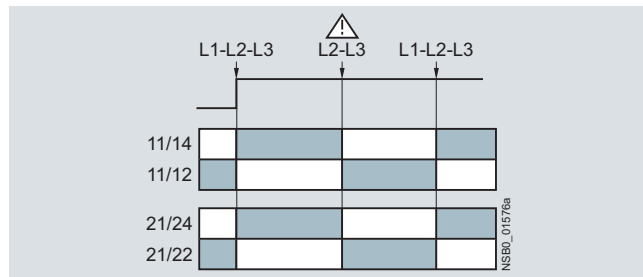

Undervoltage

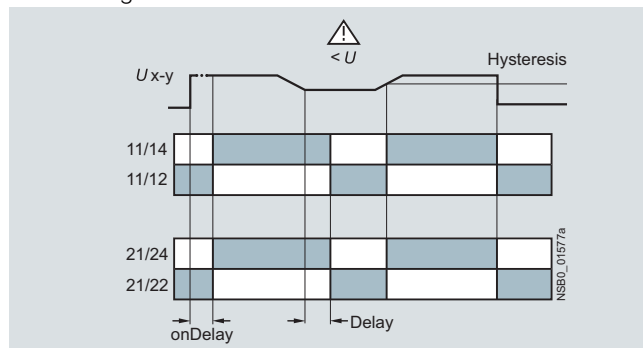

Unbalance

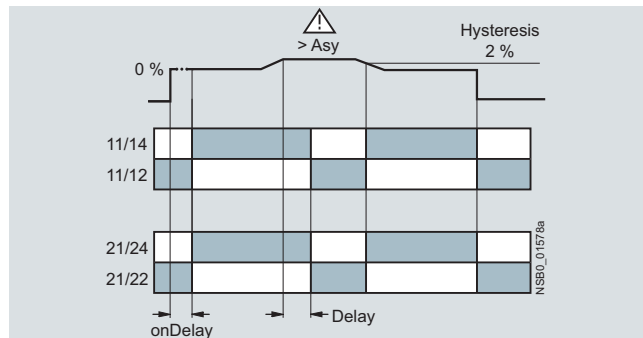

3UG Monitoring Relays for Electrical and Additional Measurements

Line monitoring

3UG46 15/3UG46 16 monitoring relays

The 3UG46 15/3UG46 16 line monitoring relay has a wide voltage range and an internal power supply. The device is equipped with a display and is parameterized using three buttons. The 3UG46 15 device monitors three-phase networks with regard to phase failure, undervoltage, overvoltage and phase sequence. The 3UG46 16 monitoring relay monitors the neutral conductor as well. The hysteresis is adjustable from 1 ... 20 V. In addition the device has two separately adjustable delay times for overvoltage and undervoltage from 0 ... 20 s in each case. If the direction is incorrect, the device switches off immediately. Thanks to a special measuring method, a phase failure is reliably detected in spite of the wide voltage range from 160 ... 690 V AC and feedback through the load of up to 80 %.

The 3UG46 15/ 3UG46 16 monitoring relay can be operated on the basis of either the open-circuit or closed-circuit principle and with manual or auto RESET.

With the closed-circuit principle selected

Wrong phase sequence

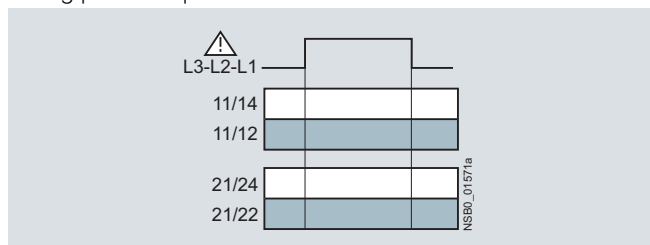

Phase failure

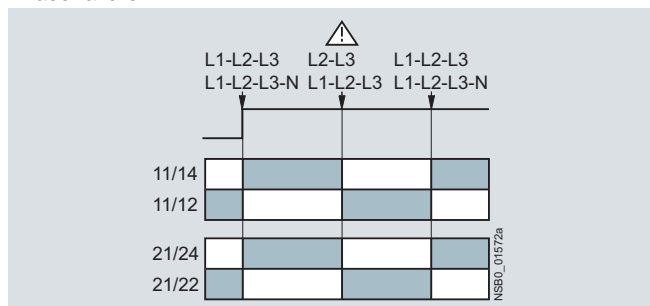

Undervoltage

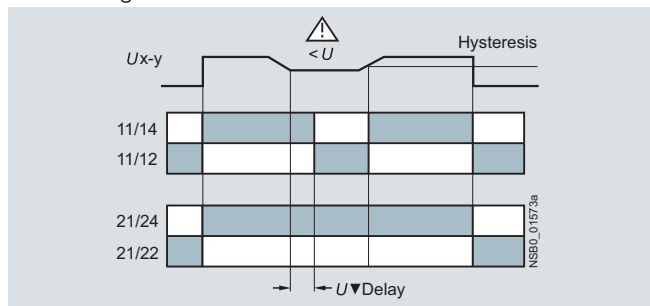

Overvoltage

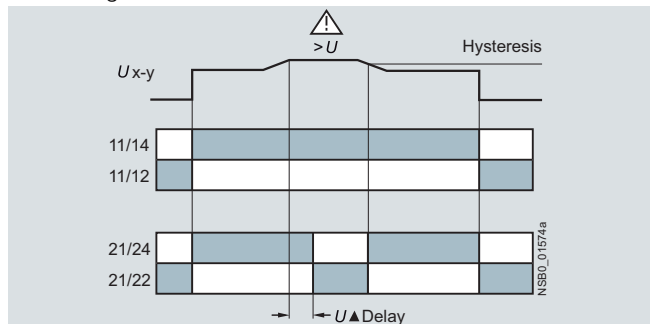

3UG46 17/3UG46 18 monitoring relays

The 3UG46 17/ 3UG46 18 line monitoring relay has an internal power supply and can automatically correct a wrong direction of rotation. Thanks to a special measuring method, a phase failure is reliably detected in spite of the wide voltage range from 160 ... 690 V AC and feedback through the load of up to 80 %. The device is equipped with a display and is parameterized using three buttons. The 3UG46 17 line monitoring relay monitors three-phase networks with regard to phase sequence, phase failure, phase unbalance, undervoltage and overvoltage. The 3UG46 18 monitoring relay monitors the neutral conductor as well. The hysteresis is adjustable from 1 ... 20 V. In addition the device has delay times from 0 ... 20 s in each case for overvoltage, undervoltage, phase failure and phase unbalance. The 3UG46 17/ 3UG46 18 monitoring relay can be operated on the basis of either the open-circuit or closed-circuit principle and with manual or auto RESET. The one changeover contact is used for warning or disconnection in the event of power system faults (voltage, unbalance), the other responds only to a wrong phase sequence. In conjunction with a contactor reversing assembly it is thus possible to change the direction automatically.

With the closed-circuit principle selected

Phase failure

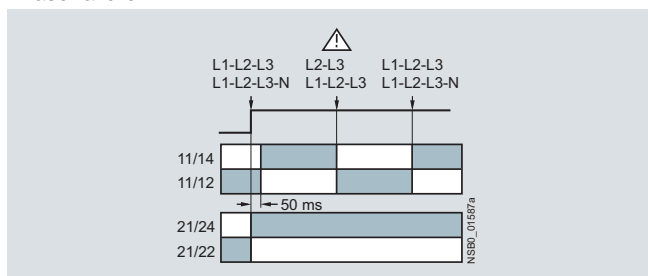

Undervoltage

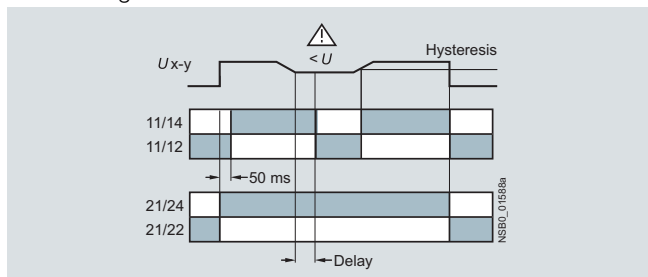

Overvoltage

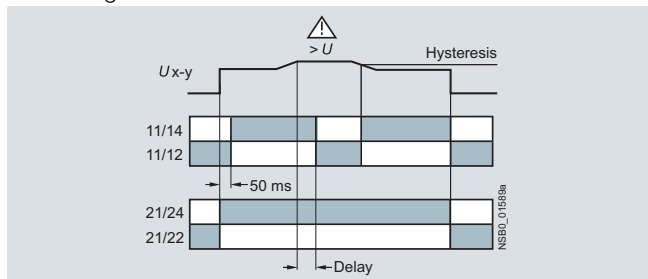

Unbalance

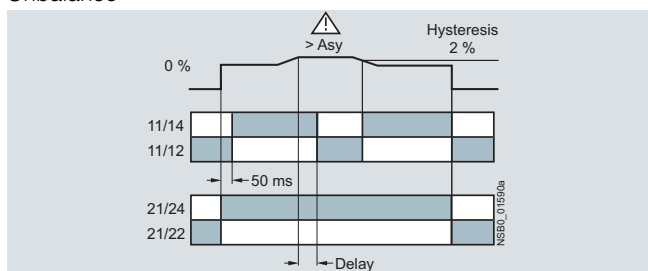



Monitoring Relays

3UG Monitoring Relays for Electrical and Additional Measurements

Line monitoring

Technical specifications

Type		3UG45 11- ..N20	3UG45 11- ..P20	3UG45 11- ..Q20	3UG45 12	3UG45 13	3UG46 14	3UG46 15 3UG46 17	3UG46 16 3UG46 18	
General data										
Rated control supply voltage U_s¹⁾	V	160 ... 260	320 ... 500	420 ... 690	160 ... 690				90 ... 400	
Rated frequency	Hz	50/60								
Rated power , typical										
• At AC 230 V	W/VA	2/4	--	--	2/2.5					
• At AC 400 V	W/VA	--	2/8	--	2/3.5					
• At AC 460 V	W/VA	--	--	2/8	2/4					
Width	mm	22.5								
RESET		Auto-RESET						Automatic/manual		
Principle of operation		Closed-circuit						Closed-circuit, open-circuit (3UG46 17/3UG46 18: closed-circuit)		
Availability time after application of U_s	ms	200			1.000					
Response time once a switching threshold is reached	ms	Max. 450								
Unbalance	%	--			10	20	0; 5 ... 20	3UG46 15/3UG46 16: Through threshold values 3UG46 17/3UG46 18: 0; 5 ... 20		
Adjustable tripping delay time	s	--				0.1 ... 20				
Adjustable ON-delay time	s	--					0.1 ... 20	--		
Mains buffering time , minimum	ms	10			30					
Rated insulation voltage U_i Degree of pollution 3 Overvoltage category III acc. to EN 60664-1	V	690								
Rated impulse withstand voltage	kV	6								
Permissible ambient temperature										
• During operation	°C	-25 ... +60								
• During storage	°C	-40 ... +85								
EMC tests²⁾		IEC 60947-/IEC 61000-6-2/IEC 61000-6-4								
Degree of protection										
• Enclosure		IP40								
• Terminals		IP20								
Vibration resistance acc. to IEC 60068-2-6		1 ... 6 Hz: 15 mm; 6 ... 500 Hz: 2 g								
Shock resistance acc. to IEC 60068-2-27		12 shocks (half-sine 15 g/11 ms)								
Connection type		 Screw terminals								
• Terminal screw		M 3 (standard screwdriver, size 2 and Pozidriv 2)								
• Solid	mm ²	1 x (0.5 ... 4)/2 x (0.5 ... 2.5)								
• Finely stranded with end sleeve	mm ²	1 x (0.5 ... 2.5)/2 x (0.5 ... 1.5)								
• AWG cables, solid or stranded	AWG	2 x (20 ... 14)								
• Tightening torque	Nm	0.8 ... 1.2								
Connection type		 Spring-type terminals								
• Solid	mm ²	2 x (0.25 ... 1.5)								
• Finely stranded, with end sleeves acc. to DIN 46228	mm ²	2 x (0.25 ... 1.5)								
• Finely stranded	mm ²	2 x (0.25 ... 1.5)								
• AWG cables, solid or stranded	AWG	2 x (24 ... 16)								
Measuring circuit										
Measuring range AC 50/60 Hz rms value	V	160 ... 260	320 ... 500	420 ... 690	160 ... 690					
Setting range	V					200...690	160...690		90...400	
Measuring accuracy	%	--				±5				
Repeat accuracy At constant parameters	%	--				±1				
Setting accuracy		--				±10 % referred to setting	±1 V			
Accuracy of digital display		--					±1 digit			
Deviations for temperature fluctuations	%/°C	--				±0.1				
Hysteresis for voltage	V	--				5 % from setting	1 ... 20 V			
Hysteresis for unbalance	%	--					(setting - 2) 3UG46 17/3UG46 18: (setting - 2)			
Deviation for frequency fluctuation	%	--				±1				

1) Absolute limit values.

2) Important: This is a Class A product. In the household environment this device may cause radio interference. In this case the user must introduce suitable measures.

Monitoring Relays

3UG Monitoring Relays for Electrical and Additional Measurements

Line monitoring

	3UG45 11- ..N20	3UG45 11- ..P20	3UG45 11- ..Q20	3UG45 12	3UG45 13	3UG46 14	3UG46 15 3UG46 17	3UG46 16 3UG46 18
Control circuit								
Load capacity of the output relay								
• Conventional thermal current I_{th}	A	5						
Rated operational current I_g at								
• AC-15/24 ... 400 V	A	3						
• DC-13/24 V	A	1						
• DC-13/125 V	A	0.2						
• DC-13/250 V	A	0.1						
Minimum contact load at 17 V DC	mA	5						
Output relay with DIAZED fuse gL/gG operational class	A	4						
Electrical endurance AC-15	Million operating cycles	0.1						
Mechanical endurance	Million operating cycles	10						

Dimensional drawings

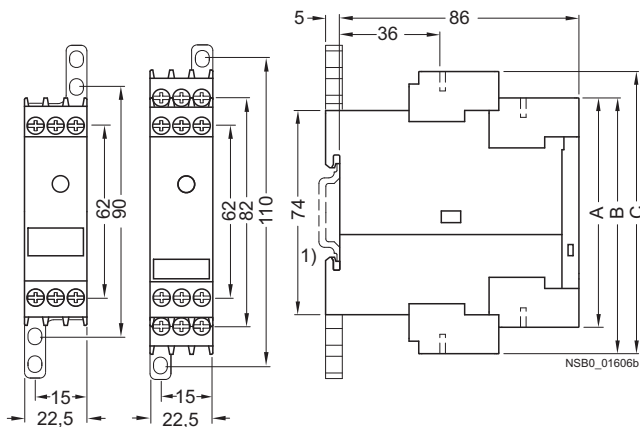

Type	3UG45 11-.A 3UG45 12-.A	3UG45 11-.B 3UG45 12-.B 3UG45 13 3UG46 14 3UG46 15 3UG46 17	3UG46 16 3UG46 18
	A	B	C

Removable terminal

Screw-type terminal	83	92	102
Spring-loaded terminal	84	94	103

1) For standard mounting rail according to EN 60715.

Monitoring Relays

3UG Monitoring Relays for Electrical and Additional Measurements

Line monitoring

Schematics

3UG45 11-A
3UG45 12-A

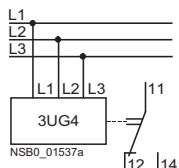

3UG45 11-B
3UG45 12-B
3UG45 13
3UG46 14
3UG46 15
3UG46 17

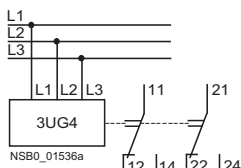

3UG46 16
3UG46 18

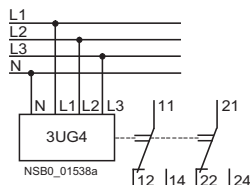

Note: It is not necessary to protect the measuring circuit for device protection. The protective device for line protection depends on the cross-section used.

Position of the terminals

3UG45 11-A
3UG45 12-A

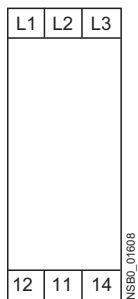

3UG45 11-B
3UG45 12-B
3UG45 13
3UG46 14
3UG46 15
3UG46 17

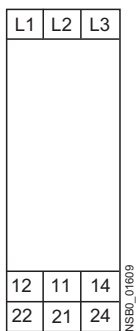

3UG46 16
3UG46 18

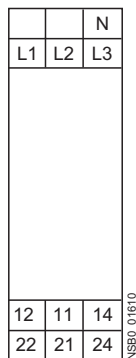

7

3UG Monitoring Relays for Electrical and Additional Measurements

Voltage monitoring

Overview



The relays monitor single-phase AC voltages (rms value) and DC voltages against the set threshold value for overshoot and undershoot. The devices differ with regard to their power supply (internal or external).

Function

3UG46 33 monitoring relays

The 3UG46 33 voltage monitoring relay has an internal power supply and performs overshoot, undershoot or window monitoring of the voltage depending on how it is parameterized. The device is equipped with a display and is parameterized using three buttons.

The operating and measuring range extends from 17 ... 275 V AC/DC. The threshold values for overshoot or undershoot can be freely configured within this range. If one of these threshold values is reached, the output relay responds according to the set principle of operation as soon as the tripping delay time has elapsed. This delay time U_{Del} can be set from 0.1 ... 20 s like the ON-delay time on_{Del} .

The hysteresis is adjustable from 0.1 ... 150 V. The device can be operated on the basis of either the open-circuit or closed-circuit principle and with manual or auto RESET. One output changeover contact is available as signaling contact.

With the closed-circuit principle selected

Overvoltage

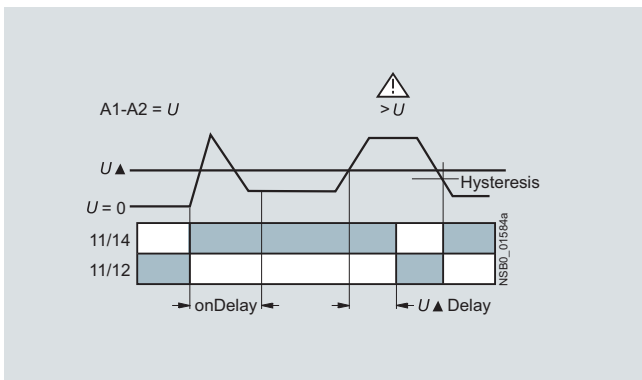

Undervoltage

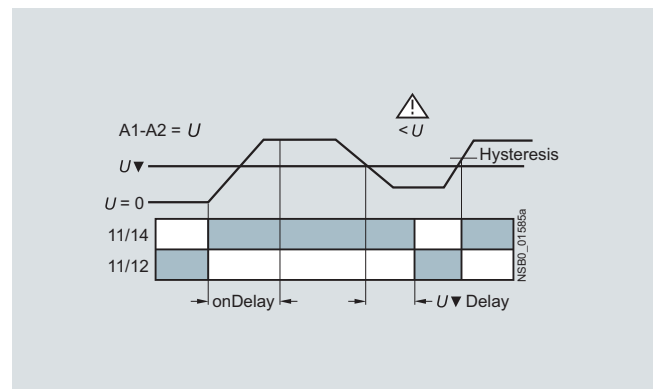

Window monitoring

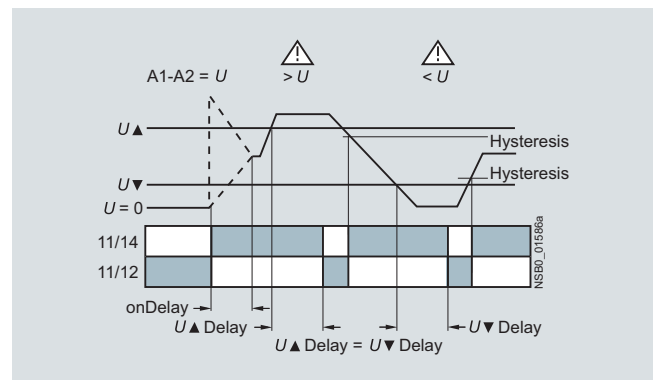

Monitoring Relays

3UG Monitoring Relays for Electrical and Additional Measurements

Voltage monitoring

3UG46 31/3UG46 32 monitoring relays

The 3UG46 31/3UG46 32 voltage monitoring relay is supplied with an auxiliary voltage of 24 V AC/DC or 24 ... 240 V AC/DC and performs overshoot, undershoot or window monitoring of the voltage depending on how it is parameterized. The device is equipped with a display and is parameterized using three buttons.

The measuring range extends from 0.1 V ... 60 V or 10 ... 600 V AC/DC. The threshold values for overshoot or undershoot can be freely configured within this range. If one of these threshold values is reached, the output relay responds according to the set principle of operation as soon as the delay time has elapsed. This delay time U_{Del} can be set from 0.1 ... 20 s. The hysteresis can be set from 0.1 ... 30 V or 0.1 ... 300 V. The device can be operated on the basis of either the open-circuit or closed-circuit principle and with manual or auto RESET. One output changeover contact is available as signaling contact.

With the closed-circuit principle selected

Overvoltage

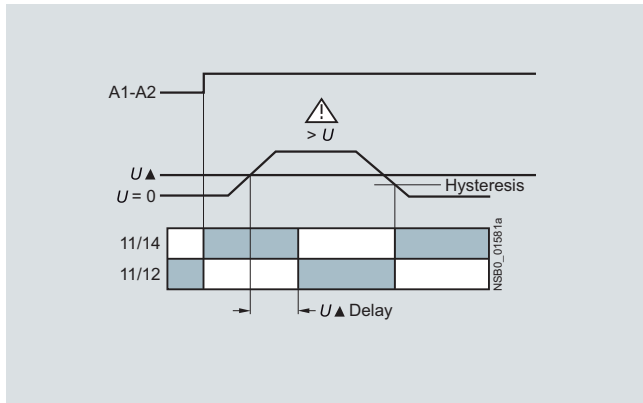

Undervoltage

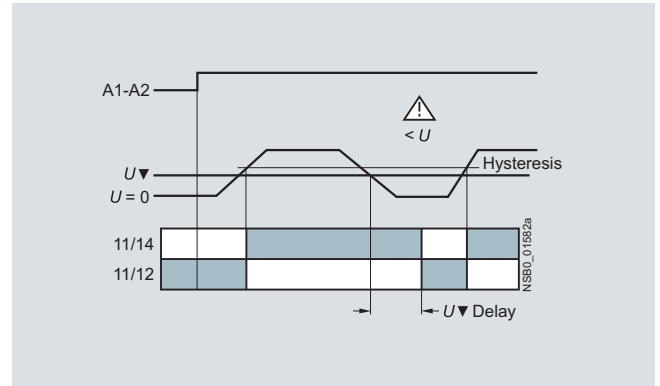

Window monitoring

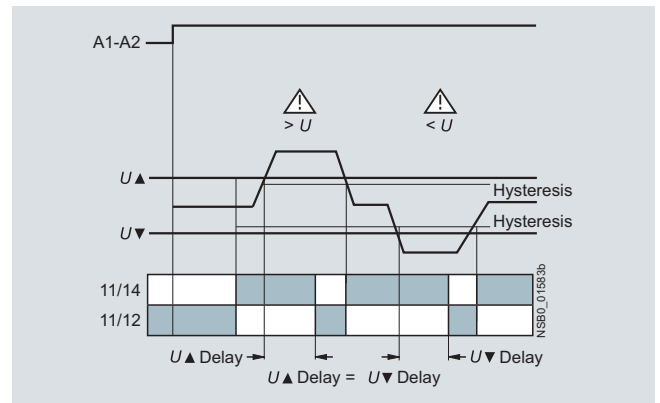



7

Monitoring Relays

3UG Monitoring Relays for Electrical and Additional Measurements

Voltage monitoring

Technical specifications

		3UG46 31- .AA	3UG46 31- .AW	3UG46 32- .AA	3UG46 32- .AW	3UG46 33
General data						
Rated control supply voltage U_g	V	24 AC/DC	24...240 AC/DC	24 AC/DC	24...240 AC/DC	17 ... 275 ¹⁾ AC/DC
Rated frequency for AC	Hz	50/60				40 ... 500
Operating range	V	20.4 ... 27.6	20.4 ... 264	20.4 ... 27.6	20.4 ... 264	17...275
Rated power in W/VA	VA	2/4				
Width	mm	22.5				
RESET		Automatic/manual				
Availability time after application of U_g	ms	1000				
Response time once a switching threshold is reached	ms	Max. 450				
Adjustable tripping delay time	s	0.1 ... 20				
Adjustable ON-delay time	s	--				0.1 ... 20
Mains buffering time , minimum	ms	10				
Rated insulation voltage U_i Degree of pollution 3 Overvoltage category III acc. to EN 60664-1	V	690				
Rated impulse withstand voltage U_{imp}	kV	6				
Protective separation acc. to EN 60947-1, Annex N	V	300				
Permissible ambient temperature • During operation • During storage	°C	-25 ... +60 -40 ... +85				
EMC tests²⁾		IEC 60947-1/IEC 61000-6-2/IEC 61000-6-4				
Degree of protection • Enclosure • Terminals		IP40 IP20				
Vibration resistance acc. to IEC 60068-2-6		1 ... 6 Hz: 15 mm; 6 ... 500 Hz: 2 g				
Shock resistance acc. to IEC 60068-2-27		12 shocks (half-sine 15 g/11 ms)				
Connection type		 Screw terminals				
• Terminal screw • Solid • Finely stranded with end sleeve • AWG cables, solid or stranded • Tightening torque	mm ² mm ² AWG Nm	M 3 (standard screwdriver, size 2 and Pozidriv 2) 1 x (0.5 ... 4)/2 x (0.5 ... 2.5) 1 x (0.5 ... 2.5)/2 x (0.5 ... 1.5) 2 x (20 ... 14) 0.8 ... 1.2				
Connection type		 Spring-type terminals				
• Solid • Finely stranded, with end sleeves acc. to DIN 46228 • Finely stranded • AWG cables, solid or stranded	mm ² mm ² mm ² AWG	2 x (0.25 ... 1.5) 2 x (0.25 ... 1.5) 2 x (0.25 ... 1.5) 2 x (24 ... 16)				
Measuring circuit						
Permissible measuring range single-phase AC/DC voltage	V	0.1 ... 68		10 ... 650		17 ... 275
Setting range single-phase voltage	V	0.1 ... 60		10 ... 600		17 ... 275
Measuring frequency	Hz	40 ... 500				40 ... 500
Measuring accuracy	%	5				
Repeat accuracy at constant parameters	%	1				
Accuracy of digital display		±1 digit				
Deviations for temperature fluctuations	%/°C	±0.1				
Hysteresis for single-phase voltage	V	0.1 ... 30		0.1 ... 300		0.1 ... 150
Control circuit						
Load capacity of the output relay • Conventional thermal current I_{th}	A	5				
Rated operational current I_g at • AC-15/24 ... 400 V • DC-13/24 V • DC-13/125 V • DC-13/250 V	A	3 1 0.2 0.1				
Minimum contact load at 17 V DC	mA	5				
Output relay with DIAZED fuse gL/gG operational class	A	4				
Electrical endurance AC15	Million operating cycles	0.1				
Endurance with contactor relay	Million operating cycles	10				

1) Absolute limit values.

2) Important: This is a Class A product. In the household environment this device may cause radio interference. In this case the user must introduce suitable measures.

Monitoring Relays

3UG Monitoring Relays for Electrical and Additional Measurements

Voltage monitoring

Dimensional drawings

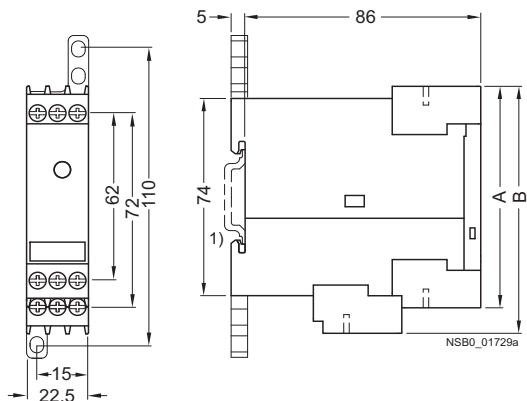

Type	3UG46 31	3UG46 32	3UG46 33
	A	B	

Removable terminal

Screw-type terminal	83	92
Spring-loaded terminal	84	94

1) For standard mounting rail according to EN 60715.

Schematics

3UG46 31-AA30
3UG46 32-AA30

3UG46 31-AW30
3UG46 32-AW30

3UG46 33

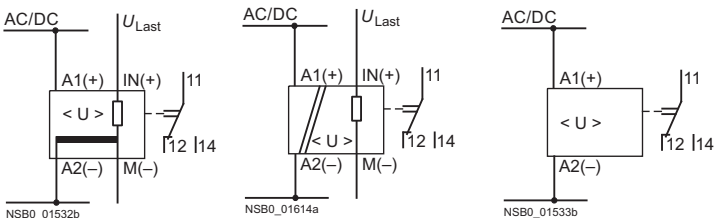

Note: It is not necessary to protect the measuring circuit for device protection. The protective device for line protection depends on the cross-section used.

Position of the terminals

3UG46 31
3UG46 32

3UG46 33

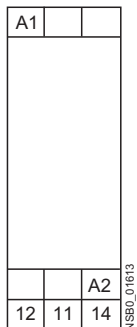
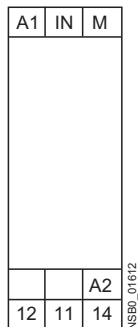

Monitoring Relays

3UG Monitoring Relays for Electrical and Additional Measurements

Current monitoring

Overview



The relays monitor single-phase AC currents (rms value) and DC currents against the set threshold value for overshoot and undershoot. They differ with regard to their measuring ranges and supply voltage types.

Function

3UG46 21/3UG46 22 monitoring relays

The 3UG46 21/3UG46 22 current monitoring relay is supplied with an auxiliary voltage of 24 V AC/DC or 24 ... 240 V AC/DC and performs overshoot, undershoot or window monitoring of the current depending on how it is parameterized. The device is equipped with a display and is parameterized using three buttons.

The measuring range extends from 3 ... 500 mA or 0.05 ... 10 A. The rms value of the current is measured. The threshold values for overshoot or undershoot can be freely configured within this range. If one of these threshold values is reached, the output relay responds according to the set principle of operation as soon as the tripping delay time I_{Del} has elapsed. This time and the ON-delay time on_{Del} are adjustable from 0.1 ... 20 s.

The hysteresis is adjustable from 0.1 ... 250 mA or 0.01 ... 5 A. The device can be operated with manual or auto RESET and on the basis of either the open-circuit or closed-circuit principle. Following options are available: Response of the output relay when the supply voltage $U_s = ON$ is applied or not until the lower measurement range limit of the measuring current ($I > 3 \text{ mA}/50 \text{ mA}$) is reached. One output changeover contact is available as signaling contact.

With the closed-circuit principle selected upon application of the supply voltage

Current overshoot

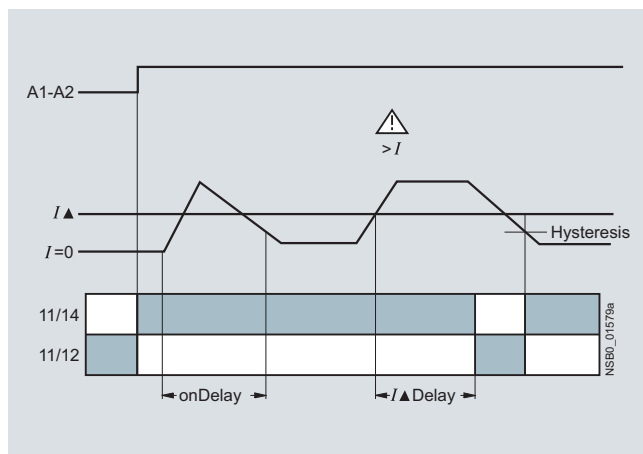

Current undershoot

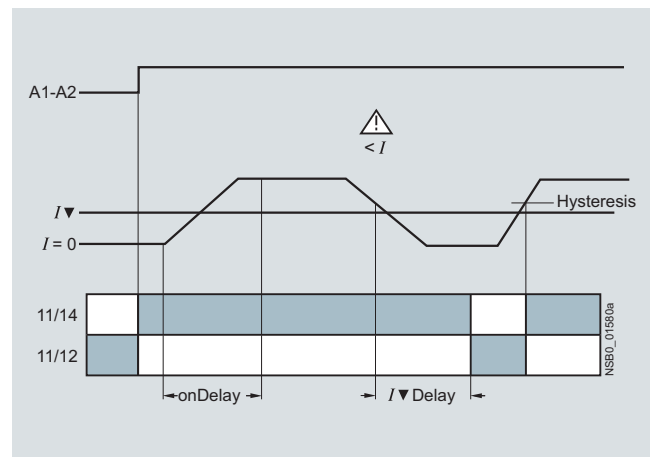

Window monitoring

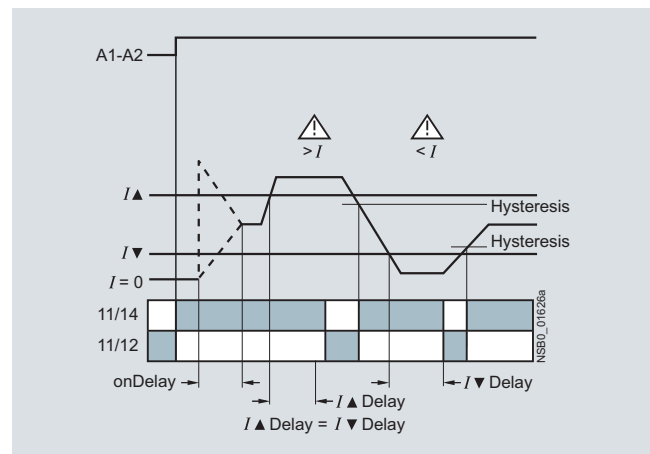



Monitoring Relays

3UG Monitoring Relays for Electrical and Additional Measurements

Current monitoring

Technical specifications

		3UG46 21-AA	3UG46 21-AW	3UG46 22-AA	3UG46 22-AW
General data					
Rated control supply voltage U_s	V	24	24 ... 240	24	24 ... 240
Rated frequency	Hz	50/60			
Operating range	V	20.4 ... 26.4	20.4 ... 264	20.4 ... 26.4	20.4 ... 264
Rated power	W/VA	2/4			
Width	mm	22.5			
RESET		Automatic/manual			
Availability time after application of U_s	ms	1000			
Response time once a switching threshold is reached	ms	Max. 450			
Adjustable tripping delay time/ON-delay time	s	0.1 ... 20			
Mains buffering time , minimum	ms	10			
Rated insulation voltage U_i Degree of pollution 3; overvoltage category III acc. to EN 60664-1	V	690			
Rated impulse withstand voltage U_{imp}	kV	6			
Protective separation acc. to EN 60947-1, Annex N	V	300			
Permissible ambient temperature					
• During operation	°C	-25 ... +60			
• During storage	°C	-40 ... +85			
EMC tests¹⁾		IEC 60947-1/IEC 61000-6-2/IEC 61000-6-4			
Degree of protection					
• Enclosure		IP40			
• Terminals		IP20			
Vibration resistance acc. to IEC 60068-2-6		1 ... 6 Hz: 15 mm; 6 ... 500 Hz: 2 g			
Shock resistance acc. to IEC 60068-2-27		12 shocks (half-sine 15 g/11 ms)			
Connection type		 Screw terminals			
• Terminal screw		M 3 (standard screwdriver, size 2 and Pozidriv 2)			
• Solid	mm ²	1 x (0.5 ... 4)/2 x (0.5 ... 2.5)			
• Finely stranded with end sleeve	mm ²	1 x (0.5 ... 2.5)/2 x (0.5 ... 1.5)			
• AWG cables, solid or stranded	AWG	2 x (20 ... 14)			
• Tightening torque	Nm	0.8 ... 1.2			
Connection type		 Spring-type terminals			
• Solid	mm ²	2 x (0.25 ... 1.5)			
• Finely stranded, with end sleeves acc. to DIN 46228	mm ²	2 x (0.25 ... 1.5)			
• Finely stranded	mm ²	2 x (0.25 ... 1.5)			
• AWG cables, solid or stranded	AWG	2 x (24 ... 16)			
Measuring circuit					
Measuring range for single-phase AC/DC current	A	0.003 ... 0.6		0.05 ... 15	
Setting range for single-phase current	A	0.003 ... 0.5		0.05 ... 10	
Load supply voltage	V	24	Max. 300 ²⁾ Max. 500 ³⁾	24	Max. 300 ²⁾ Max. 500 ³⁾
Measuring accuracy	%	5			
Repeat accuracy at constant parameters	%	1			
Accuracy of digital display		±1 digit			
Deviations for temperature fluctuations	%/°C	±0.1			
Hysteresis for single-phase current		0.1 ... 250 mA		0.01 ... 5 A	
Permissible overcurrent, continuous	A	0.6		15	
Permissible overcurrent, < 1 s	A	5		50	
Protection against destruction , DIAZED gL/gG	A	2		16	
Measuring circuit internal resistance , shunt	mΩ	500		5	
Control circuit					
Load capacity of the output relay					
• Conventional thermal current I_{th}	A	5			
Rated operational current I_o at					
• AC-15/24 ... 400 V	A	3			
• DC-13/24 V	A	1			
• DC-13/125 V	A	0.2			
• DC-13/250 V	A	0.1			
Minimum contact load at 17 V DC	mA	5			
Output relay with DIAZED fuse gL/gG	A	4			
Electrical endurance AC15 (million operating cycles)		0.1			
Endurance with contactor relay (million operating cycles)		10			

1) Important: This is a Class A product. In the household environment this device may cause radio interference. In this case the user must introduce suitable measures.

2) With protective separation.

3) With simple separation.

Monitoring Relays

3UG Monitoring Relays for Electrical and Additional Measurements

Current monitoring

Dimensional drawings

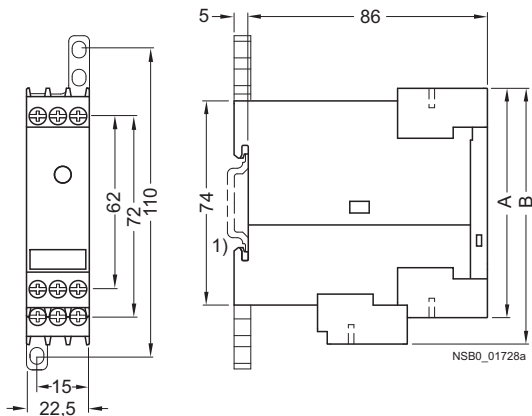

Type	3UG46 21	3UG46 22
	A	B

Removable terminal

Screw-type terminal	83	92
Spring-loaded terminal	84	94

1) For standard mounting rail according to EN 60715.

Schematics

3UG46 21-AA30 3UG46 22-AA30

Operation with separate control circuit and load circuit

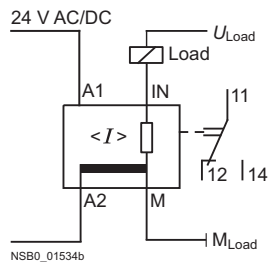

Operation with joint control circuit and load circuit

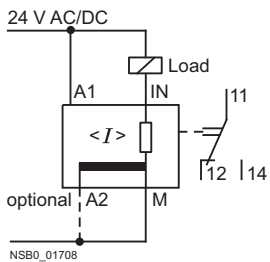

Position of the terminals

3UG46 21 3UG46 22

A1	IN	M
		A2
12	11	14

NSB0_01611

3UG46 21-AW30 3UG46 22-AW30

Single-phase operation

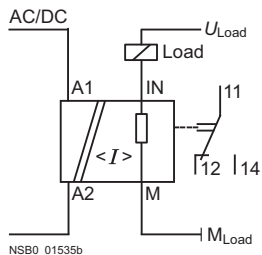

3-phase operation

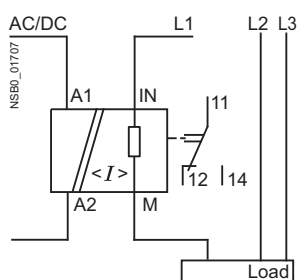

Monitoring Relays

3UG Monitoring Relays for Electrical and Additional Measurements

Current monitoring

Wiring diagram for 24 V AC/DC (only 3UG46 2.-AA30)

From the following circuit diagrams it is clear that loads in measuring circuits have to be in the current flow upstream from the monitoring relay. Otherwise, the monitoring relay could be destroyed and the short-circuit current could cause damage to the plant.

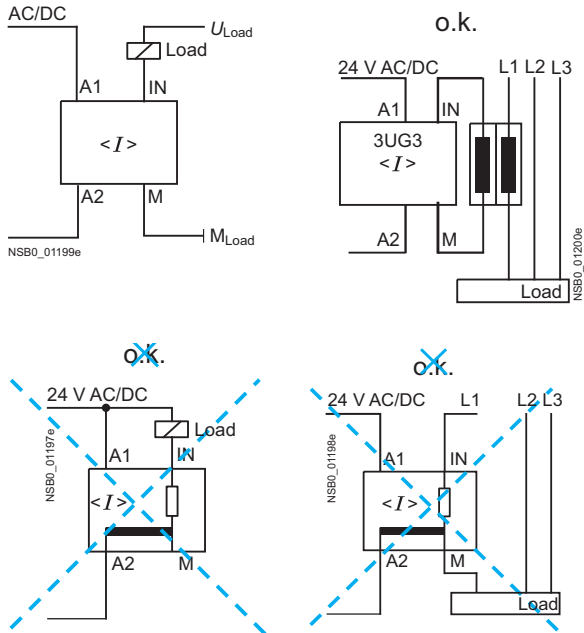

Configuring note:

A2 and M are electrically connected internally!

For applications in which the load to be monitored and the monitoring relay are supplied from the same power supply, there is no need for connection A2!

The load current must always flow through M or the monitoring relay may be destroyed!

Monitoring Relays

3UG Monitoring Relays for Electrical and Additional Measurements

Power factor and active current monitoring

Overview



The 3UG46 41 power factor and active current monitoring device enables the load monitoring of motors.

Whereas power factor monitoring is used above all for monitoring no-load operation, the active current monitoring option can be used to observe and evaluate the load factor over the entire torque range.

Function

3UG46 41 monitoring relays

The 3UG46 41 monitoring relay is self-powered and serves the single-phase monitoring of the power factor or performs overshoot, undershoot or window monitoring of the active current depending on how it is parameterized.

The load to be monitored is connected in front of the IN terminal. The load current flows over the IN and Ly/N terminals. The setting range for the power factor is 0.1 ... 0.99 and for the active current I_{res} 0.2 ... 10 A.

If the supply voltage is switched on and no load current is flowing, the display indicates $I < 0.2$ and a symbol for overshoot, undershoot or window monitoring.

If the motor is now switched on and the current exceeds 0.2 A, the set ON-delay time begins. During this time, an undershooting or overshooting of the set limit values will not lead to a relay response of the changeover contact.

If the operational flowing active current and/or the power factor value falls below or exceeds the respective set threshold value, the spike delay begins. When this time has expired, the relay changes its switch position. The relevant measured variables for overshooting and undershooting in the display flashes. If the monitoring of active current undershooting is deactivated ($I_{res} \nabla = \text{OFF}$) and the load current drops below the lower measurement range threshold (0.2 A), then the CO contacts remain unchanged. If a threshold value is set for the monitoring of active current undershooting, then undershooting of the measurement range threshold (0.2 A) will result in a response of the CO contacts.

The relay operates either according to the open-circuit or closed-circuit principle.

If the device is set to Auto-RESET (Memory = No), depending on the set principle of operation, the switching relay returns to its initial state and the flashing ends when the hysteresis threshold is reached.

If manual reset is selected in the menu (Memory = Yes), the switching relay remains in its current switching state and the current measured value and the symbol for undershooting and overshooting continues to flash, even when the measured variable reaches a permissible value again. This stored fault status can be reset by pressing the UP▲ and DOWN▼ key simultaneously for 2 seconds, or by switching the supply voltage off and back on again.

With the closed-circuit principle selected

Behavior upon undershooting of the measurement range limit with activated monitoring of $I_{res} \nabla$

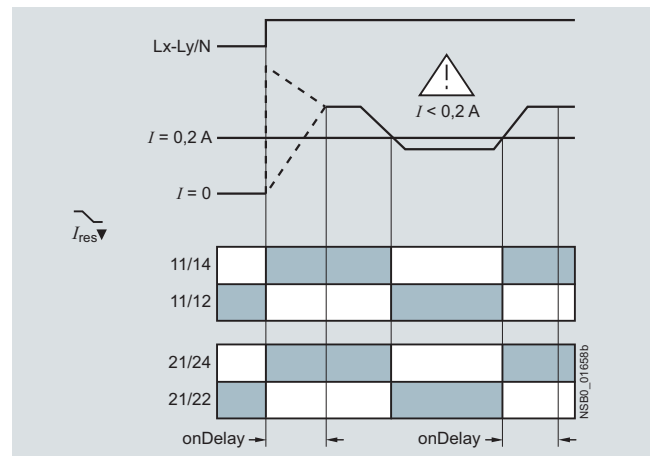

Behavior upon undershooting of the measurement range limit with deactivated monitoring of active current undershooting

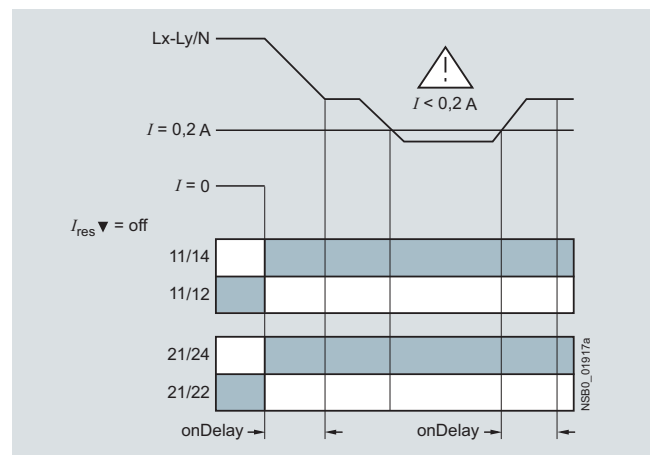

Monitoring Relays

3UG Monitoring Relays for Electrical and Additional Measurements

Power factor and active current monitoring

Overshooting of active current

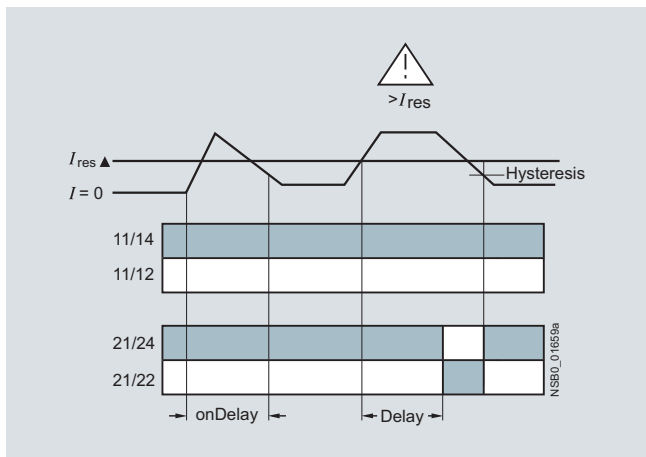

Overshooting of power factor

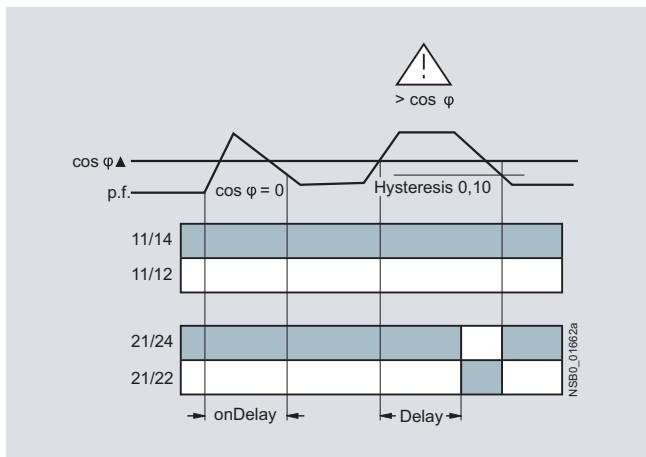

Undershooting of active current

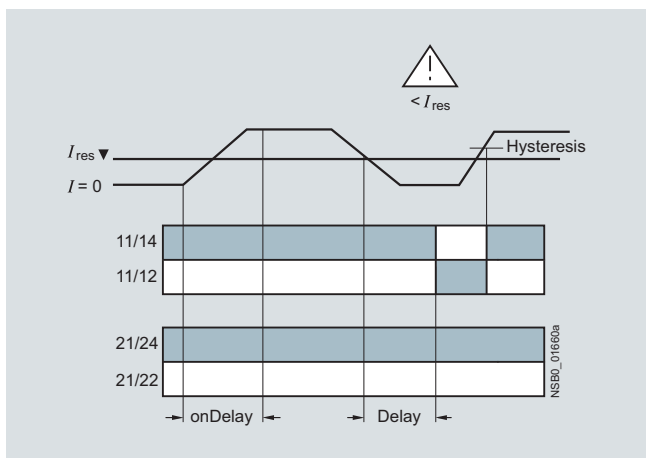

Undershooting of power factor

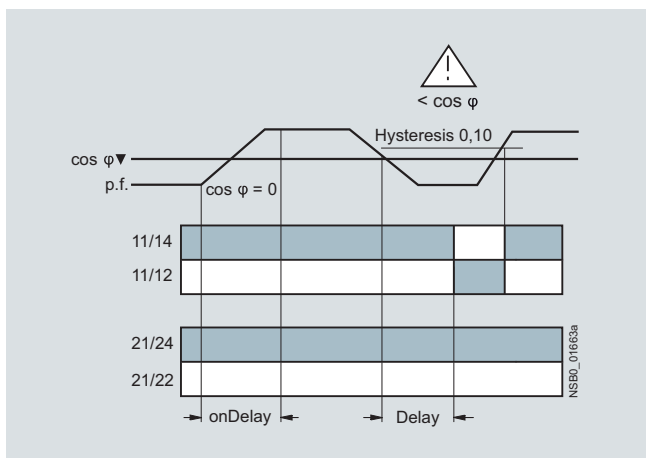

Window monitoring of active current

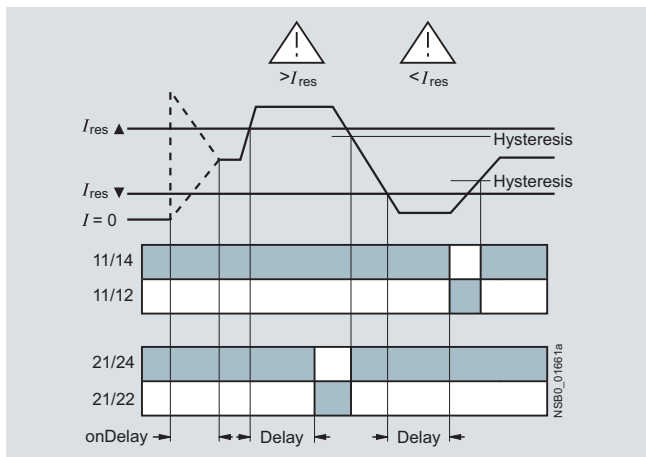

Window monitoring of power factor

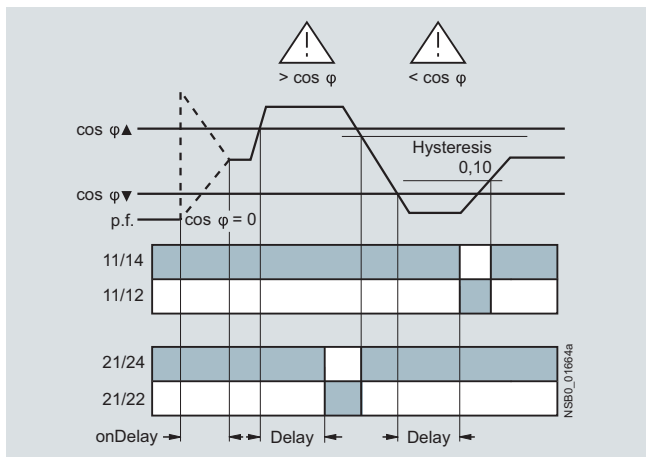

Legend

cos φ: p. f.



7

Monitoring Relays

3UG Monitoring Relays for Electrical and Additional Measurements

Power factor and active current monitoring

Technical specifications

Type	3UG46 41	
General data		
Rated control supply voltage U_s	V	90 ... 690
Rated frequency	Hz	50/60
Rated power, typical	VA	2.0
• At 200 V AC	VA	2.7
• At 400 V AC	VA	3.1
• At 460 V AC		
Width	mm	22.5
RESET		Automatic/manual
Principle of operation		Closed-circuit principle, open-circuit principle
Availability time after application of U_s	ms	1000
Response time once a switching threshold is reached	ms	Max. 450
Adjustable tripping delay time	s	0.1 ... 20
Adjustable ON-delay time	s	0 ... 99
Mains buffering time, minimum	ms	10
Rated insulation voltage U_i	V	690
Degree of pollution 3		
Overvoltage category III acc. to EN 60664-1		
Rated impulse withstand voltage	kV	6
Permissible ambient temperature	°C	-25 ... +60
• During operation	°C	-40 ... +85
• During storage		
EMC tests ¹⁾		IEC 60947-1/IEC 61000-6-2/IEC 61000-6-4
Degree of protection		IP40
• Enclosure		IP20
• Terminals		
Vibration resistance acc. to IEC 60068-2-6		1 ... 6 Hz: 15 mm; 6 ... 500 Hz: 2 g
Shock resistance acc. to IEC 60068-2-27		12 shocks (half-sine 15 g/11 ms)
Connection type		 Screw terminals
• Terminal screw		M 3 (standard screwdriver, size 2 and Pozidriv 2)
• Solid	mm ²	1 x (0.5 ... 4)/2 x (0.5 ... 2.5)
• Finely stranded with end sleeve	mm ²	1 x (0.5 ... 2.5)/2 x (0.5 ... 1.5)
• AWG cables, solid or stranded	AWG	2 x (20 ... 14)
• Tightening torque	Nm	0.8 ... 1.2
Connection type		 Spring-type terminals
• Solid	mm ²	2 x (0.25 ... 1.5)
• Finely stranded, with end sleeves acc. to DIN 46228	mm ²	2 x (0.25 ... 1.5)
• Finely stranded	mm ²	2 x (0.25 ... 1.5)
• AWG cables, solid or stranded	AWG	2 x (24 ... 16)
Measuring circuit		
Measurable active current I_{res}	A	0.2 ... 10
Max. permissible load current	A	10
Peak current < 1 s	A	50
Adjustable response value		0.1 ... 0.99
Phase displacement angle		
DIAZED protection, gL/gG operational class	A	16
Measuring accuracy	%	10
Repeat accuracy at constant parameters	%	1
Accuracy of digital display		± 1 digit
Deviations for temperature fluctuations	%/°C	±0.1
Hysteresis		0.10
Phase angle		
Hysteresis	A	0.1 ... 2.0
Active current monitoring		

¹⁾ Important: This is a Class A product. In the household environment this device may cause radio interference. In this case the user must introduce suitable measures.

Monitoring Relays

3UG Monitoring Relays for Electrical and Additional Measurements

Power factor and active current monitoring

Type	3UG46 41	
Control circuit		
Number of CO contacts for auxiliary contacts		2
Load capacity of the output relay		
• Conventional thermal current I_{th}	A	5
Rated operational current I_o at		
• AC-15/24 ... 400 V	A	3
• DC-13/24 V	A	1
• DC-13/125 V	A	0.2
• DC-13/250 V	A	0.1
Minimum contact load at 17 V DC	mA	5
Output relay with DIAZED fuse gL/gG operational class	A	4
Electrical endurance AC-15	Million operating cycles	0.1
Mechanical endurance	Million operating cycles	10

Dimensional drawings

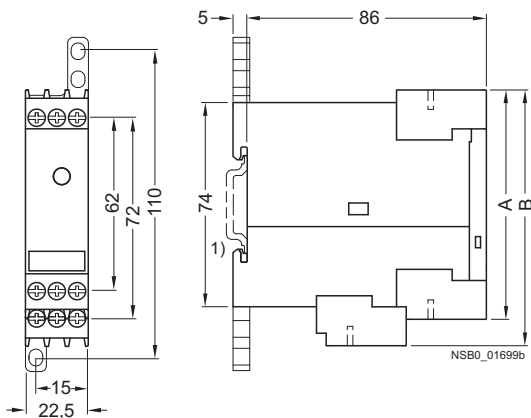

Type	3UG46 41	
	A	B

Removable terminal

Screw-type terminal	83	92
Spring-loaded terminal	84	94

1) For standard mounting rail according to EN 60715.

Monitoring Relays

3UG Monitoring Relays for Electrical and Additional Measurements

Power factor and active current monitoring

Schematics

Single-phase motors

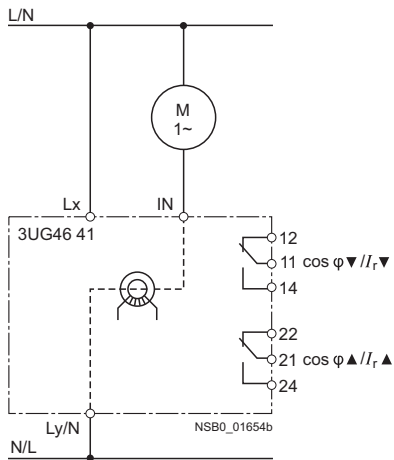

3-phase motors

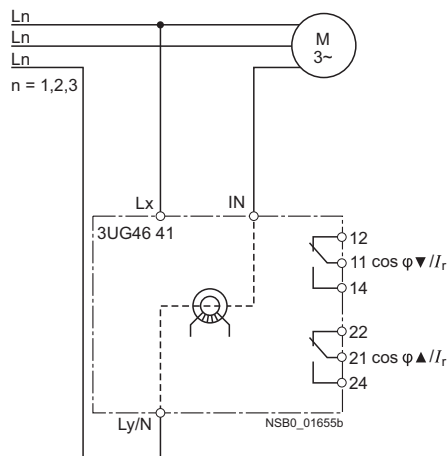

3-phase motors with transformers for currents > 10 A

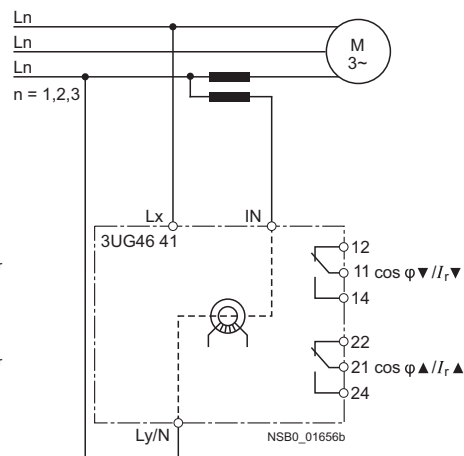

Legend

cos φ: p. f.

Position of the terminals

3UG46 41

Lx	Ly/N	IN
12	11	14
22	21	24

NSB0_01657

Monitoring Relays

3UG Monitoring Relays for Electrical and Additional Measurements

Residual current monitoring: Residual-current monitoring relays

Overview

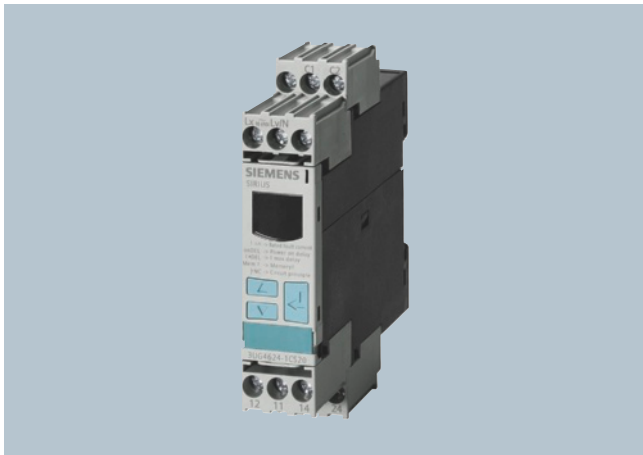

The 3UG46 24 residual current monitoring relay is used together with the 3UL22 summation current transformer for plant monitoring.

Function

3UG46 24 monitoring relays

The main conductor and any neutral conductor to which a load is connected, are routed through the opening of the annular strip-wound core of a summation current transformer. A secondary winding is placed around this annular strip-wound core to which the monitoring relay is connected.

If operation of a plant is fault-free, the sum of the inflowing and outward currents equals zero. In this case, no voltage is induced in the secondary winding of the summation current transformer.

However, if an insulation fault occurs downstream of the residual current operated circuit breaker, the sum of the inflowing currents is greater than that of the outward currents.

The differential current - the residual current - induces a secondary current in the secondary winding of the transformer. This current is evaluated in the monitoring relay and is used on the one hand to display the actual residual current and on the other, to switch the relay if the set warning or tripping threshold is overshoot.

If the measured residual current exceeds the set warning value, the associated changeover contact instantly changes the switching state and an indication appears on the display. If the measured residual current exceeds the set tripping value, the set delay time begins and the associated relay symbol flashes. On expiry of this time, the associated changeover contact changes the switching state.

ON-delay time for motor start

To be able to start a motor, once the auxiliary voltage has been applied for an adjustable ON-delay time, and depending on whether the open-circuit or closed-circuit principle is selected, the output relay switches to the GO state.

The changeover contacts do not react if the set threshold value is overshoot during this period.

3UG Monitoring Relays for Electrical and Additional Measurements

Residual current monitoring: Residual-current monitoring relays

With the closed-circuit principle selected

Residual current monitoring with Auto-RESET (Memory = no)

If the device is set to Auto-RESET (Memory = No), the relay switches for the tripping value once the value falls below the set hysteresis threshold and the display stops flashing. The associated relay changes its switching state if the value falls below the fixed hysteresis value of 5 % of the warning value. Any overshoots are therefore not stored.

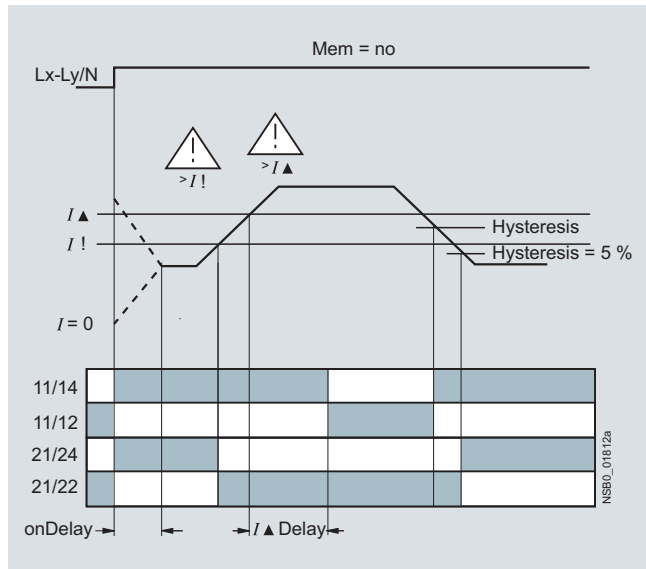

Note:

The neutral conductor must not be grounded downstream of the summation current transformer as this may impair the function of the residual current monitoring device.

Residual current monitoring with Manual-RESET (Memory = yes)

If Manual-RESET is selected in the menu, the output relay remains in its current switching state and the current measured value and the symbol for overshooting continues to flash, even when the measured residual current returns to a permissible value. This stored fault status can be reset by pressing the UP▲ and DOWN▼ key simultaneously for > 2 seconds, or by switching the supply voltage off and back on again.

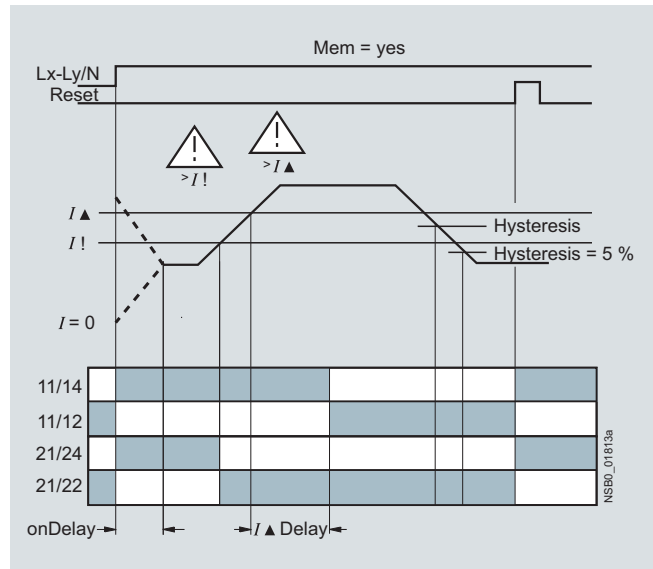



Monitoring Relays

3UG Monitoring Relays for Electrical and Additional Measurements

Residual current monitoring: Residual-current monitoring relays

Technical specifications

Type	3UG46 24	
General data		
Rated control supply voltage U_s	V	90 ... 690 ¹⁾
Rated frequency	Hz	50/60
Rated power, typical		
• At 90 V AC	VA	2.8
• At 230 V AC	VA	2.4
• At 400 V AC	VA	3.1
• At 460 V AC	VA	3.2
• At 690 V AC	VA	4.7
Width	mm	22.5
RESET		Automatic/manual
Principle of operation		Closed-circuit principle, open-circuit principle
Availability time after application of U_s	ms	1000
Response time once a switching threshold is reached	ms	Max. 300
Adjustable delay time	s	0.1... 20
Mains buffering time, minimum	ms	10
Rated insulation voltage U_i Degree of pollution 3 Overvoltage category III acc. to EN 60664-1	V	690
Rated impulse withstand voltage	kV	6
Permissible ambient temperature		
• During operation	°C	-25 ... +60
• During storage	°C	-40 ... +85
EMC tests²⁾		IEC 60947-1/IEC 61000-6-2/IEC 61000-6-4
Degree of protection		
• Enclosure		IP40
• Terminals		IP20
Vibration resistance acc. to IEC 60068-2-6		1 ... 6 Hz: 15 mm; 6 ... 500 Hz: 2 g
Shock resistance acc. to IEC 60068-2-27		12 shocks (half-sine 15 g/11 ms)
Connection type		 Screw terminals
• Terminal screw		M3 (for standard screw driver size 2 and Pozidriv 2)
• Solid	mm ²	1 x (0.5 ... 4)/2 x (0.5 ... 2.5)
• Finely stranded with end sleeve	mm ²	1 x (0.5 ... 2.5)/2 x (0.5 ... 1.5)
• AWG cables, solid or stranded	AWG	2 x (20 ... 14)
• Tightening torque	NM	0.8 ... 1.2
Connection type		 Spring-type terminals
• Solid	mm ²	2 x (0.25 ... 1.5)
• Finely stranded, with end sleeves acc. to DIN 46228	mm ²	2 x (0.25 ... 1.5)
• Finely stranded	mm ²	2 x (0.25 ... 1.5)
• AWG cables, solid or stranded	AWG	2 x (24 ... 16)
Measuring circuit		
Measurable residual current I_{res}	A	10 ... 120 % $I_{\Delta n}$ ($I_{\Delta n}$: rated residual current of the transformer)
Adjustable response value		
• Residual current		10 ... 100 % $I_{\Delta n}$
• Warning		10 ... 100 % $I_{\Delta n}$
Measuring accuracy	%	±5
Repeat accuracy at constant parameters	%	±1
Accuracy of digital display		± 1 digit
Deviations for temperature changes	%/°C	±0.1
Hysteresis for residual current		LSB ³⁾ up to 50 % $I_{\Delta n}$
Hysteresis for warning threshold	A	5 % $I_{\Delta n}$

1) Absolute limit values.

2) Important: This is a Class A product. In the household environment this device may cause radio interference. In this case the user must take suitable precautions.

3) LSB: Smallest adjustable value, transformer-dependent, ≤ 1 % of $I_{\Delta n}$.

Monitoring Relays

3UG Monitoring Relays for Electrical and Additional Measurements

Residual current monitoring:
Residual-current monitoring relays

Type	3UG46 24	
Control circuit		
Number of CO contacts for auxiliary contacts	2	
Load capacity of the output relay		
Conventional thermal current I_{th}	A	5
Rated operational current I_e at		
• AC-15/24 ... 400 V	A	3
• DC-13/24 V	A	1
• DC-13/125 V	A	0.2
• DC-13/250 V	A	0.1
Minimum contact load at 17 V DC	mA	5
Output relay with DIAZED fuse gL/gG operational class	A	4
Electrical endurance AC-15	Million operating cycles	0.1
Mechanical endurance	Million operating cycles	10

Dimensional drawings

3UG46 24

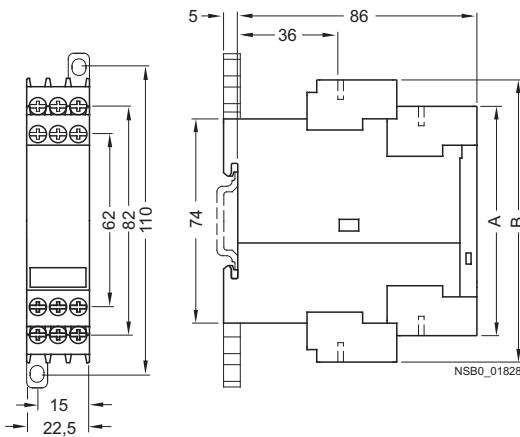

Type	3UG46 24	
	A	B

Removable terminal

Screw-type terminal	83	102
Spring-loaded terminal	84	103

1) For standard mounting rail according to EN 60715.

Monitoring Relays

3UG Monitoring Relays for Electrical and Additional Measurements

Residual current monitoring: Residual-current monitoring relays

Schematics

3UG46 24

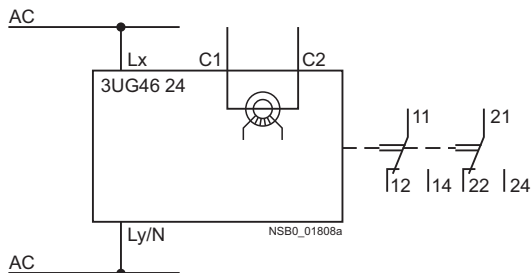

Position of the terminals

	C1	C2
Lx	Ly/N	
12	11	14
22	21	24

NSBO_01825

Note: It is not necessary to protect the measuring circuit for device protection. The protective device for line protection depends on the cross-section used.

Circuit example

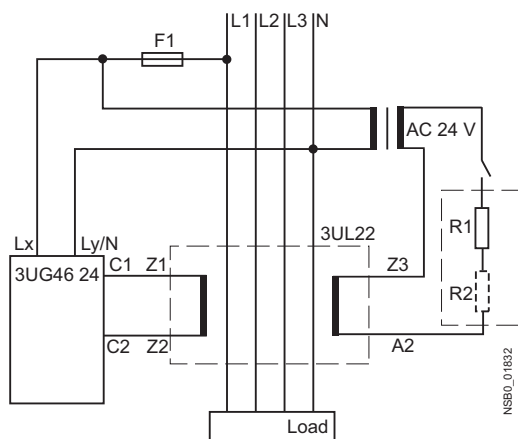

Type	$I_{\Delta n}$	R1	R2
3UL22 0.-1A	0,3 A	220 Ω \geq 3 W	--
3UL22 0.-2A	0,5 A		
3UL22 0.-3A	1 A		
3UL22 0.-1B	6 A	22 Ω \geq 6 W	22 Ω \geq 6 W
3UL22 0.-2B	10 A		
3UL22 0.-3B	16 A		
3UL22 0.-4B	25 A		
3UL22 0.-5B	40 A		

Monitoring Relays

3UG Monitoring Relays for Electrical and Additional Measurements

Residual current monitoring:
3UL22 summation current transformers

Overview

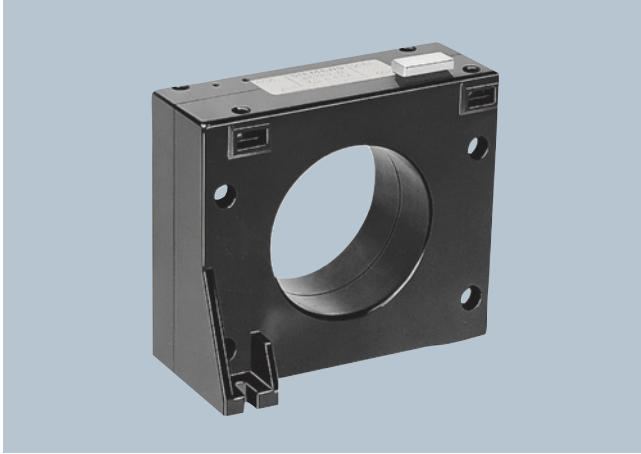

The 3UL22 summation current transformers detect fault currents in machines and plants. Together with the 3UG46 24 residual current monitoring relay or the SIMOCODE 3UF motor management and control device they enable residual-current and ground-fault monitoring.

Technical specifications

Summation current transformers

Type		3UL22 01	3UL22 02	3UL22 03
Rated insulation voltage U_i	AC 50/60 Hz	690 V		1000 V
Rated residual current $I_{\Delta n}$ Without response delay	A	0.3 ... 1	0.3 ... 40	0.3 ... 40
Permissible ambient temperature	°C	-20 ... +70		
Feed-through openings	mm	40	65	120
For Protodur cables Can be fed through	Max. mm ²	4 x 95	4 x 240	8 x 300

Dimensional drawings

3UL22 summation current transformer

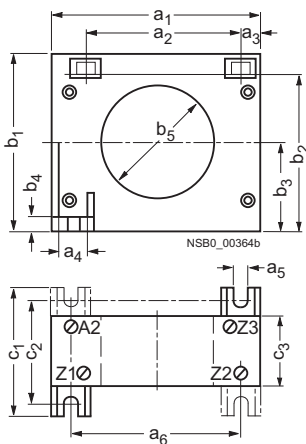

Type	a ₁	a ₂	a ₃	a ₄	a ₅	a ₆	b ₁	b ₂	b ₃	b ₄	b ₅	c ₁	c ₂	c ₃
3UL22 01	100	75	10	15	for M4	80	85	72.5	42.5	7.5	40	65	50	40
3UL22 02	125	95	10	15	for M4	100	110	97.5	55	7.5	65	70	60	45
3UL22 03	200	165	20	20	for M4	170	200	100	100	10	120	85	70	55

Monitoring Relays

3UG Monitoring Relays for Electrical and Additional Measurements

Insulation monitoring
For ungrounded AC networks

Overview



Relay for monitoring the insulation resistance between the ungrounded single or three-phase AC supply and a protective conductor

- Measuring principle with superimposed DC voltage
- Two selectable measuring ranges of 1 ... 110 k Ω
- Stepless setting within the measuring range
- Selectable:
 - Auto reset function with fixed hysteresis or
 - Storage of the tripping operation
- Test function with test button and terminal connections on the front
- Switching output: 1 CO contact
- Insulation fault indication with a red LED
- Supply voltage indication with a green LED
- Electro-magnetically compatible according to EN 61000-6-2 and EN 61000-6-4

Function

The monitoring relay measures the insulation resistance between the ungrounded AC supply and an associated protective conductor.

A superposed DC measuring voltage is used to perform the measurement.

The monitoring relay is divided into two ranges for an insulation resistance range from 1 ... 100 k Ω . A range switch on the front can be used to switch over between a 1 ... 11 k Ω range and a 10 ... 110 k Ω range. Within the selected range, the monitoring relay can be steplessly adapted to the respective insulation conditions.

If the insulation resistance undershoots the set response value, the output relay is excited and the red LED (fault indication) is lit.

If the insulation resistance exceeds 1.6 times (corresponding to 60 % hysteresis) the set response value, the output relay will return to the rest position.

Test functions

The "Test" button on the front can be used to simulate a ground fault. If the "Test" button is pressed for at least 300 ms, the output relay is energized and the fault LED lights up. An external test button, which is connected to PE, can also be connected to terminal Y1. The function is activated by closing (> 300 ms).

Fault storage and RESET

If terminals Y1 and Y2 are jumpered, the monitoring relay is set to fault storage mode. If the set insulation resistance is undershot, the output relay is excited and remains tripped even after the insulation resistance rises above 1.6 times the set value again. Fault storage can be reset by briefly pressing the RESET button, briefly jumpering (< 300 ms) the Y1 and PE/ground terminals or by switching off and on the supply voltage.

Note:

The monitoring relay is designed for AC voltage systems. Series-connected rectifiers must be electrically isolated from the measuring relay.

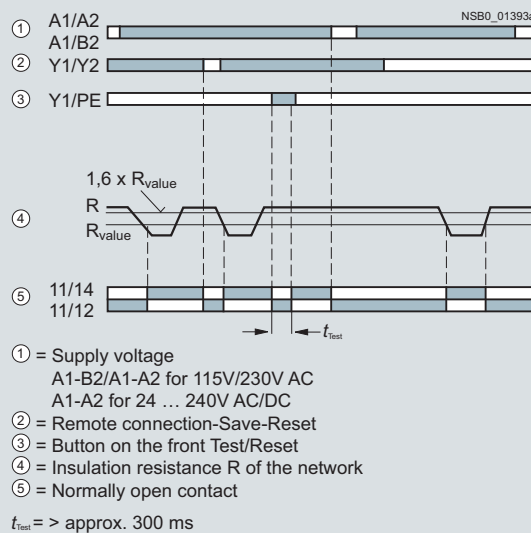

Monitoring Relays

3UG Monitoring Relays for Electrical and Additional Measurements

Insulation monitoring
For ungrounded AC networks

Technical specifications

				3UG30 81
Control circuit				
Operating range of the control supply voltage				-15 %... +10 %
Rated power	24 ... 240 V AC/DC	VA/W		8/2
	110 ... 130 V AC/DC	VA		3
	220 ... 240 V AC/DC	VA		3
Frequency of the rated control supply voltage				Hz 50 ... 60
Measuring circuit L/PE				
• Response value		kΩ		1...110
• Min. internal resistance for AC		kΩ		100
• Min. internal resistance for DC		kΩ		100
• Measurement DC voltage		V		30
• Max. AC insulation voltage (L/PE)		V		415
• Reset/test function terminals (max. 10 m)				Y1-Y2
• Delay time in case of response		s		1
Output relay				1 CO contact, open-circuit principle
General data				
Rated insulation voltage U_i	Between supply, measurement, and output circuit	V		250 acc. to IEC 60947-1
Overvoltage category	Acc. to EN 60664-1			III
Degree of pollution	Acc. to IEC 60664-1			3
Impulse withstand voltage U_{imp}	Acc. to VDE 0435, Part 303	kV		4
Degree of protection	Acc. to EN 60529			IP50 enclosure, IP20 terminals
Shock resistance	Acc. to IEC 60068-2-27	g/ms		10
Vibration resistance	Acc. to IEC 60068-2-6			10 ... 55 Hz: 0.35 mm
Permissible ambient temperature				
• During operation		°C		-25 ... 65
• During storage		°C		-40 ... 85
Permissible mounting positions				Any
Conductor cross-section	Solid	mm ²		2 x 0.75 ... 2.5
	Finely stranded with end sleeve	mm ²		2 x 0.75 ... 2.5

Dimensional drawings

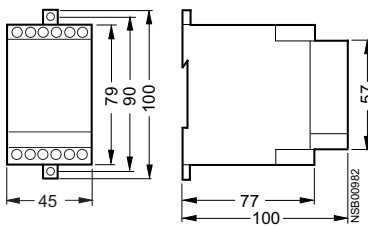

Schematics

Circuit diagram for networks up to 400 V AC

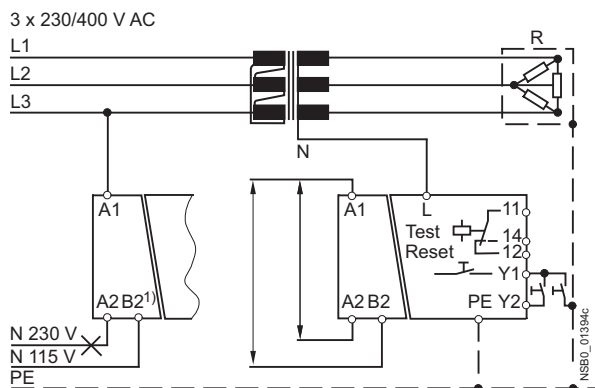

A1-A2 for 24...240 V AC/DC

A1-B2 for 115 V AC or

A1-B2 for 230 V AC

1) Only 3UG3081-1AK20.

Monitoring Relays

3UG Monitoring Relays for Electrical and Additional Measurements

Insulation monitoring
For ungrounded DC networks

Overview



Relay for monitoring the insulation resistance between ungrounded pure DC networks and a protective conductor

- Measuring principle for residual current measurement
- Response value can be adjusted steplessly from 10 ... 110 kΩ
- Selectable
 - Auto reset function with hysteresis or
 - Storage of the tripping operation
- Front selector switch for open-circuit and closed-circuit principle for the output relay
- Test function with test buttons on the front for L+ and L- and over terminal connections
- Switching output: 1 CO contact
- Insulation fault indicator for L+ and L- through two red LEDs
- Supply voltage indication with a green LED
- Electro-magnetically compatible according to EN 61000-6-2 and EN 61000-6-4

Function

The monitoring relay measures the insulation resistance between the positive and negative supply voltage in an ungrounded DC voltage network and a corresponding protective conductor.

The measurement is based on the DC residual current measurement principle. The response value can be adjusted steplessly in the range from 10 ... 110 kΩ and thus can be adapted to the corresponding conditions. If the insulation resistance falls below the set response value, the output relay triggers (depending on the setting of the open/closed-circuit principle selector switch) and a fault LED lights up.

A ground fault is evaluated separately for L+ and L- and indicated by means of a corresponding LED.

Note:

Due to the measurement principle, a symmetrical ground fault on terminals L+ and L- cannot be evaluated.

Test function

A ground fault can be simulated using the Test L+ and Test L- buttons on the front. If the test button is pressed for at least 1 s, the status of the output relay changes and the corresponding fault LED lights up.

An external test button can be connected to terminals Y1-Y3 for L+ and terminals Y4-Y3 for L-. The function is triggered by means of a NO contact.

Fault storage and RESET

If terminals Y2 and Y3 are linked, the monitoring relay is set to fault storage mode.

If the insulation resistance falls below the set value, the output relay triggers (depending on the setting of the open/closed circuit selector switch), and stays in this state even if the insulation resistance rises again above the hysteresis value (typical: 2 times the set value). This fault storage can be deleted by pressing and releasing the L+ RESET button, opening the Y2-Y3 connection or by switching off the supply voltage.

Open/closed-circuit principle selector switch

The principle of operation of the output relay can be adjusted by means of a selector switch on the front panel.

If the relay is to respond in the event of a fault (contact symbol open), the open-circuit principle must be selected. If the relay however is to trigger in the event of a fault (contact symbol closed), the closed-circuit principle must be selected.

Note:

The position of the selector switch has no effect upon the fault LEDs. The LEDs always light up if the insulation resistance on L+ or L- falls below the set value.

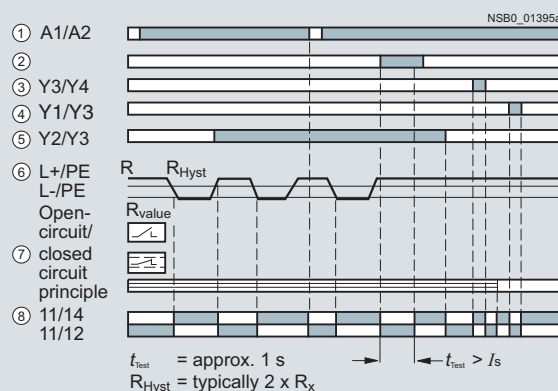

- ① = Supply voltage
- ② = Button on front – Reset L+ and L-/Test L+
- ③ = Button on front – Test L – Test remote connection – Test L
- ④ = Test remote connection – Test L+
- ⑤ = Test remote connection – Store, reset
- ⑥ = Insulation resistance R of supply set response value R
- ⑦ = Switch on front
Open-circuit/closed-circuit principle
- ⑧ = Selector switch

Monitoring Relays

3UG Monitoring Relays for Electrical and Additional Measurements

Insulation monitoring
For ungrounded DC networks

Technical specifications

		3UG30 82	
Control circuit			
Operating range of the control supply voltage			-15 %... +10 %
Rated power	24 ... 240 V AC/DC	VA/W	8/2
Frequency of the rated control supply voltage		Hz	50 ... 60
Measuring circuit			
• Response value		kΩ	10 ... 110
• Min. internal resistance for DC		kΩ	57
• Measurement DC voltage		V	24 ... 240
• Max. DC insulation voltage (L+/PE/ground, L-/PE/ground)		V	300
• Reset/test function terminals (max. 10 m)			Y1/Y3, Y4/Y3
• Delay time in case of response		s	1
Output relay			1 changeover contact, open-circuit or closed-circuit principle
General data			
Rated insulation voltage U_i	Between supply, measurement, and output circuit	V	250
Insulation resistance			
Overvoltage category	Acc. to EN 60664-1		III
Degree of pollution	Acc. to EN 60664-1		3
Impulse withstand voltage U_{imp}	Acc. to VDE 0435, Part 303	kV	4
Degree of protection	Acc. to EN 60529		IP50 enclosure, IP20 terminals
Shock resistance	Acc. to IEC 60068-2-27	g/ms	10
Vibration resistance	Acc. to IEC 60068-2-6		10 ... 55 Hz: 0.35 mm
Permissible ambient temperature			
• During operation		°C	-25 ... +65
• During storage		°C	-40 ... +85
Permissible mounting positions			Any
Conductor cross-section	Solid	mm ²	2 x 0.75 ... 2.5
	Finely stranded with end sleeve	mm ²	2 x 0.75 ... 2.5

Dimensional drawings

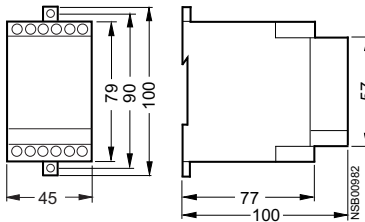

Schematics

Circuit diagram for 24 ... 240 V DC

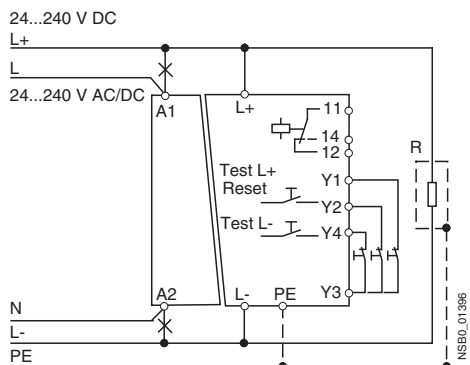

Monitoring Relays

3UG Monitoring Relays for Electrical and Additional Measurements

Level monitoring: Level monitoring relays

Overview



The 3UG45 01 level monitoring relay is used together with 2- or 3-pole sensors to monitor the levels of conductive liquids.

Function

3UG45 01 monitoring relays

The principle of operation of the 3UG45 01 level monitoring relay is based on measuring the electrical resistance of the liquid between two immersion sensors and a reference terminal. If the measured value is lower than the sensitivity set at the front, the output relay changes its switching state. In order to exclude electrolytic phenomena in the liquid, the sensors are supplied with alternating current.

Two-point control

The output relay changes its switching state as soon as the liquid level reaches the maximum sensor, while the minimum sensor is submerged. The relay returns to its original switching state as soon as the minimum sensor no longer has contact with the liquid.

Single-point control

If only one level is being controlled, the terminals for Min and Max on the monitoring relay are bridged. The output relay changes its switching state as soon as the liquid level is reached and returns to its original switching state once the sensor no longer has contact with the liquid.

In order to prevent premature tripping of the switching function caused by wave motion or frothing, even though the set level has not been reached, it is possible to delay this function by 0.5 ... 10 s.

For safe resetting, the supply voltage must be interrupted for at least the set delay time of +0.5 s.

Note:

It is also possible to connect other resistance sensors to the Min and Max terminals in the range 2 ... 200 kW, e. g. photoresistors, temperature sensors, encoders based on resistance etc. The monitoring relay can therefore also be used for other applications apart from monitoring the levels of liquids.

Monitoring Relays

3UG Monitoring Relays for Electrical and Additional Measurements

Level monitoring: Level monitoring relays

OVER, two-point control

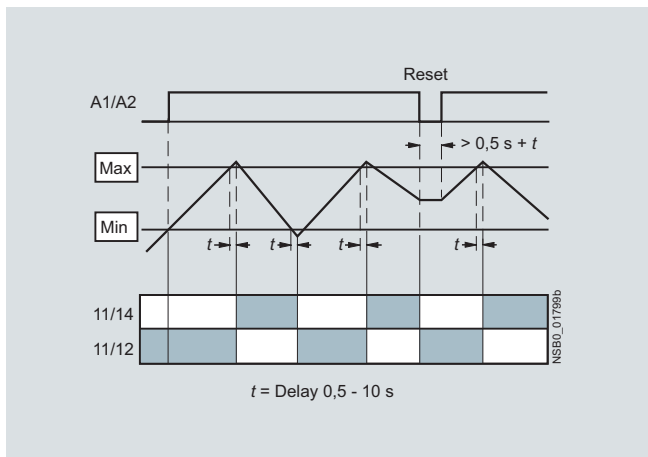

OVER, single-point control

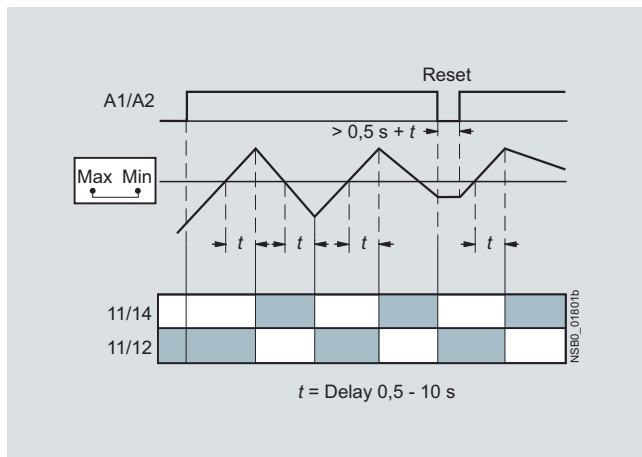

UNDER, two-point control

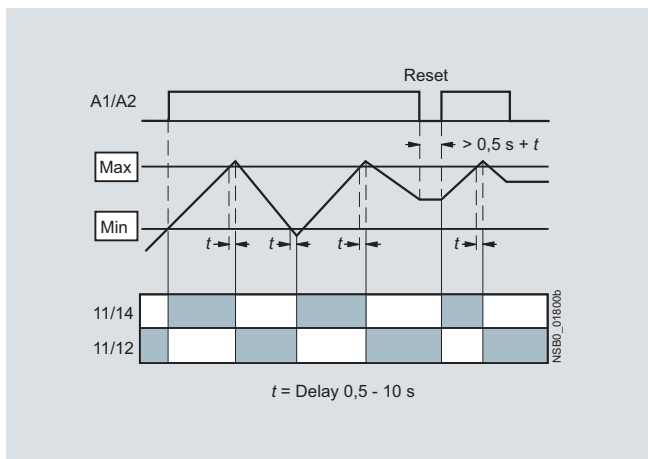

UNDER, single-point control

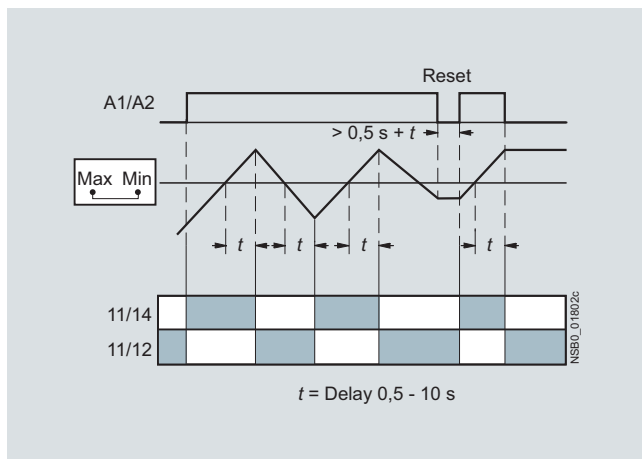



Monitoring Relays

3UG Monitoring Relays for Electrical and Additional Measurements

Level monitoring: Level monitoring relays

Technical specifications

Type		3UG45 01-1AA30, 3UG45 01-2AA30	3UG45 01-1AW30, 3UG45 01-2AW30
General data			
Rated control supply voltage U_s	V AC/DC	24	24 ... 240
Rated frequency	Hz	50/60	
Operating range	V	20.4 ... 26.4	20.4 ... 264
Rated power, max.			
• At 24 V AC	VA	2	2
• At 240 V AC	VA	--	4
Width	mm	22.5	
Availability time after application of U_s	ms	500	
Response time once a switching threshold is reached	ms	Max. 300	
Adjustable delay time	s	0.5 ... 10	
Inlet or outlet monitoring function		UNDER/OVER selector switch at the front	
Mains buffering time , minimum	ms	200	
Rated insulation voltage U_i	V	300	
Degree of pollution 3, Overtension category III acc. to EN 60664-1			
Rated impulse withstand voltage	kV	4	
Permissible ambient temperature			
• During operation	°C	-25 ... +60	
• During storage	°C	-40 ... +80	
EMC tests¹⁾		IEC 60947-1/IEC 61000-6-2/IEC 61000-6-4	
Degree of protection		IP40 IP20	
• Enclosure (acc. to EN 60529)			
• Terminals			
Vibration resistance acc. to IEC 60068-2-6		1 ... 6 Hz: 15 mm; 6 ... 500 Hz: 2 g	
Shock resistance acc. to IEC 60068-2-27		12 shocks (half-sine 15 g/11 ms)	
Connection type		 Screw terminals	
• Terminal screw		M3 (for standard screwdriver, size 2 and Pozidriv 2)	
• Solid	mm ²	1 x (0.5 ... 4)/2 x (0.5 ... 2.5)	
• Finely stranded with end sleeve	mm ²	1 x (0.5 ... 2.5)/2 x (0.5 ... 1.5)	
• AWG cables, solid or stranded	AWG	2 x (20 ... 14)	
• Tightening torque	Nm	0.8 ... 1.2	
Connection type		 Spring-type terminals	
• Solid	mm ²	2 x (0.25 ... 1.5)	
• Finely stranded, with end sleeves acc. to DIN 46228	mm ²	2 x (0.25 ... 1.5)	
• Finely stranded	mm ²	2 x (0.25 ... 1.5)	
• AWG cables, solid or stranded	AWG	2 x (24 ... 16)	
Measuring circuit			
Electrode current, max. (typ. 70 Hz)	mA	1	
Electrode voltage, max. (typ. 70 Hz)	V	15	
Sensor feeder cable	m	Max. 100	
Conductor capacity of sensor cable²⁾	nF	Max. 10	
Adjustable sensitivity			
• Resistance	kΩ	2 ... 200	
Measuring accuracy	%	±20	
Repeat accuracy at constant parameters	%	±1	
Deviations for temperature fluctuations	%/°C	±1	
Control circuit			
Number of CO contacts for auxiliary contacts		1	
Load capacity of the output relay			
Conventional thermal current I_{th}	A	5	
Rated operational current I_e at			
• AC-15/24 ... 400 V	A	3	
• DC-13/24 V	A	1	
• DC-13/125 V	A	0.2	
• DC-13/250 V	A	0.1	
Minimum contact load at 17 V DC	mA	5	
Output relay with DIAZED fuse	A	4	
gL/gG operational class			
Electrical endurance AC-15	Million operating cycles	0.1	
Mechanical endurance	Million operating cycles	10	

¹⁾ Important: This is a Class A product. In the household environment this device may cause radio interference. In this case the user must introduce suitable measures.

²⁾ The sensor cable does not necessarily have to be shielded, but we do not recommend installing this cable parallel to the power supply lines. It is also possible to use a shielded cable, whereby the shield has to be connected to the M terminal.

Monitoring Relays

3UG Monitoring Relays for Electrical and Additional Measurements

Level monitoring:
Level monitoring relays

Dimensional drawings

3UG45 01

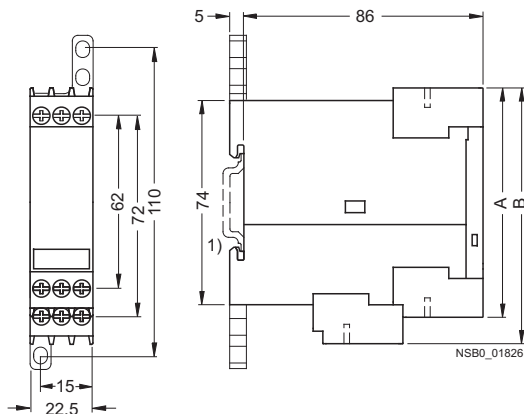

Type	3UG45 01	
	A	B

Removable terminals

Screw terminals	83	92
Spring-loaded terminals	84	94

1) For standard mounting rail according to EN 60715.

Schematics

3UG45 01

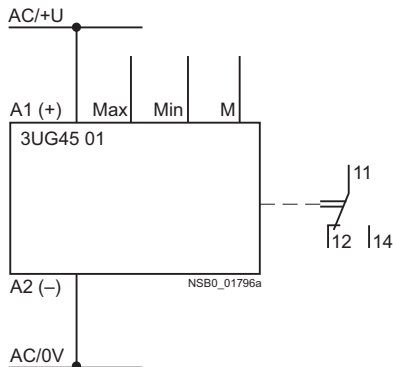

Single-point control with inlet monitoring

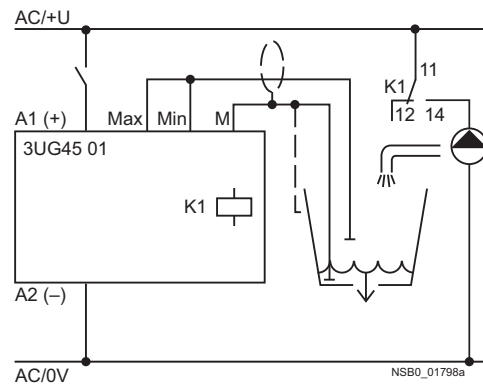

Two-point control with outlet monitoring

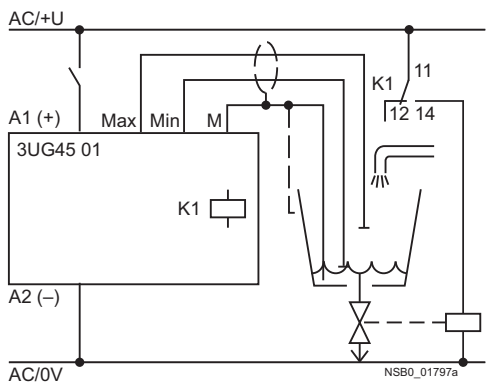

Position of the terminals

A1+	M
MIN	MAX
12	11
A2-	14

NSB0_011823

Monitoring Relays

3UG Monitoring Relays for Electrical and Additional Measurements

Level monitoring:
Level monitoring sensors

Technical specifications

Type		3UG32 07-3A three-pole	3UG32 07-2A two-pole	3UG32 07-2B two-pole	3UG32 07-1B single-pole	3UG32 07-1C single-pole
Length	mm	500	500	--	--	--
Insulation	Teflon insulation (PTFE)	Yes	Yes	Yes	--	Yes
Installation		Vertical	Vertical	Lateral	Lateral	Lateral
Screw-in gland width A/F		22				
Thread	inch	R 3/8				
Connecting cable	mm ²	3 x 0.5, 2 m long				
Operating temperature	°C	90				
Operating pressure	bar	10				
Assignment						
Cable/Electrode	<ul style="list-style-type: none"> • Cable brown • Cable white • Cable green 	Center electrode	Not assignable	Gland	Gland	Gland
		Not assignable	Not assignable	Not assignable	Electrode	Electrode
		Not assignable	--	Not assignable	--	--

Dimensional drawings

3UG32 07-3A
three-pole wire electrode

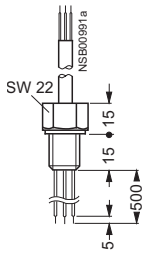

3UG32 07-1B
single-pole bow electrode

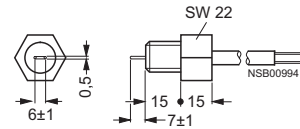

3UG32 07-2A
two-pole wire electrode

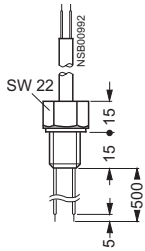

3UG32 07-1C
single-pole electrode, rugged version

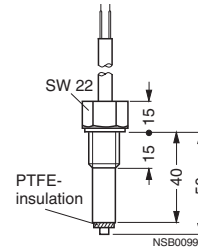

3UG32 07-2B
two-pole bow electrode

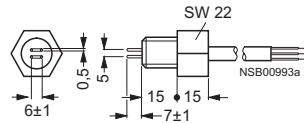

Overview

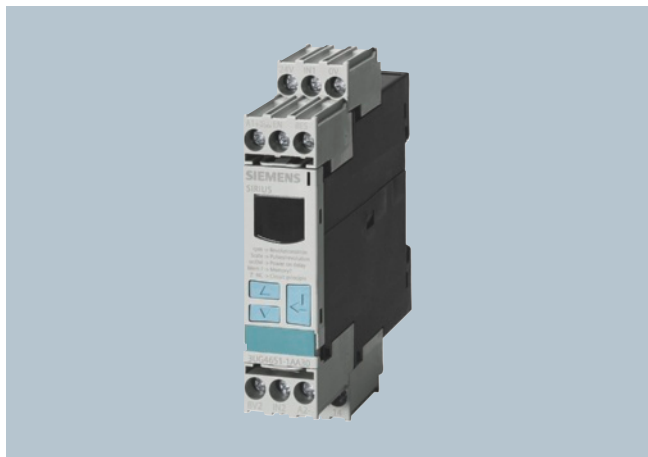

The 3UG46 51 monitoring relay is used together with a sensor to monitor motor drives for overspeed and/or underspeed.

Furthermore, this relay is ideal for all functions where a continuous pulse signal needs to be monitored (e. g. belt travel monitoring, completeness monitoring, passing monitoring, clock-time monitoring).

Function

3UG46 51 monitoring relays

The speed monitoring relay operates according to the principle of period duration measurement.

In the monitoring relay, the time between two successive rising edges of the pulse encoder is measured and compared to the minimum and/or maximum permissible period duration calculated from the set limit values for the speed.

Thus, the period duration measurement recognizes any deviation in speed after just two pulses, even at very low speeds or in the case of extended pulse gaps.

By using up to ten pulse encoders evenly distributed around the circumference, it is possible to shorten the period duration, and in turn the response time. By taking into account the number of sensors in the monitoring relay, the speed continues to be indicated in rpm.

ON-delay time for motor start

To be able to start a motor drive, and depending on whether the open-circuit or closed-circuit principle is selected, the output relay switches to the GO state during the ON-delay time, even if the speed is still below the set value.

With the closed-circuit principle selected

Window monitoring without enable input

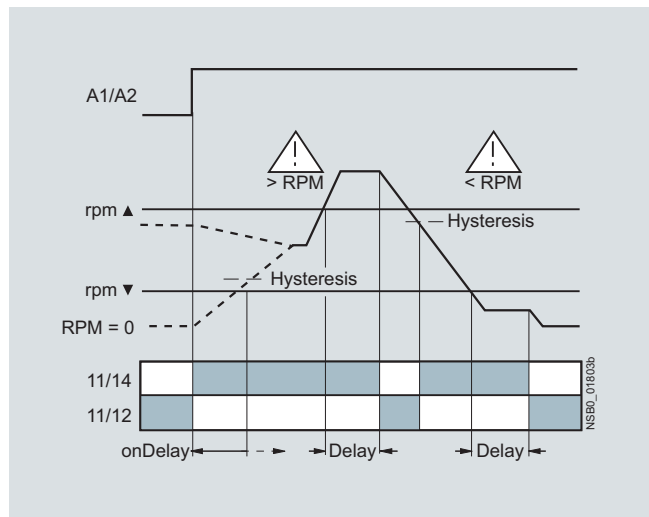

The ON-delay time is started by either switching on the auxiliary voltage or, if the auxiliary voltage is already applied, by actuating the respective NC contact (e. g. auxiliary contact).

Speed monitoring with Auto-RESET (Memory = no)

If the device is set to Auto-RESET, the output relay switches to the GO state, once the adjustable hysteresis threshold is reached in the range of 0.1 ... 99.9 rpm and the flashing stops. Any overshoots or undershoots are therefore not stored.

Speed monitoring with Manual-RESET (Memory = yes)

If Manual-RESET is selected in the menu, the output relay remains in its current switching state and the current measured value and the symbol for overshooting/undershooting continues to flash, even when the speed returns to a permissible value. This stored fault status can be reset by pressing the UP▲ and DOWN▼ buttons simultaneously for > 2 seconds, by connecting the RESET device terminal to 24 V DC or by switching the supply voltage off and back on again.

Window monitoring with enable input

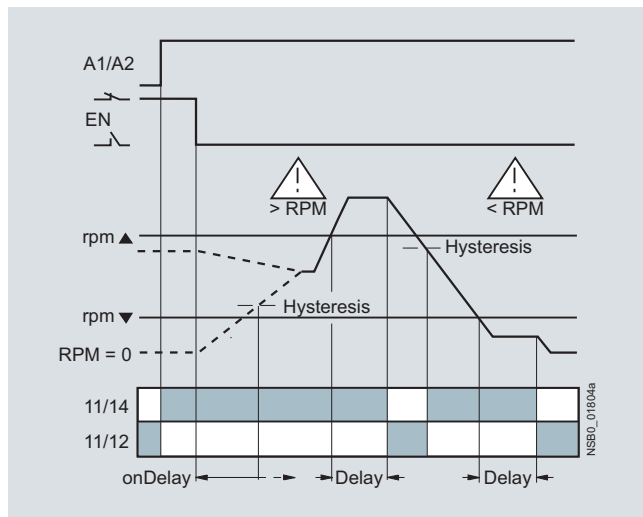



Monitoring Relays

3UG Monitoring Relays for Electrical and Additional Measurements

Speed monitoring

Technical specifications

Type		3UG46 51-1AA30, 3UG46 51-2AA30	3UG46 51-1AW30, 3UG46 51-2AW30
General data			
Rated control supply voltage U_s	V AC/DC	24	24 ... 240
Rated frequency	Hz	50/60	
Operating range	V	20.4 ... 26.4	20.4 ... 264
Rated power, max.			
• At 24 V AC	VA	2.5	4
• At 240 V AC	VA	--	9
Width	mm	22.5	
RESET		Automatic/manual	
Availability time after application of U_s	ms	500	
Response time once a switching threshold is reached	ms	Max. 300	
Adjustable tripping delay time	s	0.1 ... 99.9	
Adjustable ON-delay time	s	1 ... 900	
Principle of operation		Closed-circuit principle, open-circuit principle	
NC/NO contact behavior		Adjustable	
Mains buffering time, minimum	ms	10	
Rated insulation voltage U_i Degree of pollution 3, Overvoltage category III acc. to EN 60664-1	V	300	
Rated impulse withstand voltage	kV	4	
Permissible ambient temperature			
• During operation	°C	-25 ... +60 ¹⁾	
• During storage	°C	-40 ... +80	
EMC tests²⁾		IEC 60947-1, IEC 61000-6-2, IEC 61000-6-4	
Degree of protection			
• Enclosure (acc. to EN 60529)		IP40	
• Terminals		IP20	
Vibration resistance acc. to IEC 60068-2-6		1 ... 6 Hz: 15 mm; 6 ... 500 Hz: 2 g	
Shock resistance acc. to IEC 60068-2-27		12 shocks (half-sine 15 g/11 ms)	
Connection type		 Screw terminals	
• Terminal screw		M3 (for standard screwdriver, size 2 and Pozidriv 2)	
• Solid	mm ²	1 x (0.5 ... 4)/2 x (0.5 ... 2.5)	
• Finely stranded with end sleeve	mm ²	1 x (0.5 ... 2.5)/2 x (0.5 ... 1.5)	
• AWG cables, solid or stranded	AWG	2 x (20 ... 14)	
• Tightening torque	Nm	0.8 ... 1.2	
Connection type		 Spring-type terminals	
• Solid	mm ²	2 x (0.25 ... 1.5)	
• Finely stranded, with end sleeves acc. to DIN 46228	mm ²	2 x (0.25 ... 1.5)	
• Finely stranded	mm ²	2 x (0.25 ... 1.5)	
• AWG cables, solid or stranded	AWG	2 x (24 ... 16)	
Measuring circuit			
Sensor supply			
• For three-wire sensor (24 V/0 V)	mA	Max. 50	
• For 2-wire NAMUR sensor (8V2)	mA	Max. 8.2	
Signal input			
• IN1	kΩ	16, three-wire sensor, pnp operation	
• IN2	kΩ	1, floating contact, 2-wire NAMUR sensor	
Voltage level			
• For level 1 at IN1	V	4.5 ... 30	
• For level 0 at IN1	V	0 ... 1	
Current level			
• For level 1 at IN2	mA	> 2.1	
• For level 0 at IN2	mA	< 1.2	
Minimum pulse duration of signal	ms	5	
Minimum interval between 2 pulses	ms	5	
Adjustable response value rpm	rpm	0.1 ... 2200	
Hysteresis	rpm	OFF and 0.1 ... 99.9	
Scale		1 ... 10	
Measuring accuracy	%	±10	
Repeat accuracy at constant parameters	%	±1	
Accuracy of digital display		±1 digit	

1) At a distance of > 1 cm to adjacent devices;
if butt-mounted: +50 °C.

2) Important: This is a Class A product. In the household environment this device may cause radio interference. In this case the user must introduce suitable measures.

Monitoring Relays

3UG Monitoring Relays for Electrical and Additional Measurements

Speed monitoring

Type	3UG46 51-1AA30, 3UG46 51-2AA30	3UG46 51-1AW30, 3UG46 51-2AW30
Control circuit		
Number of CO contacts for auxiliary contacts	1	
Load capacity of the output relay		
Conventional thermal current I_{th}	A	5
Rated operational current I_e at		
• AC-15/24 ... 400 V AC/DC	A	3
• DC-13/24 V	A	1
• DC-13/125 V	A	0.2
• DC-13/250 V	A	0.1
Minimum contact load at 17 V DC	mA	5
Output relay with DIAZED fuse gL/gG operational class	A	4
Electrical endurance AC-15	Million operating cycles	0.1
Mechanical endurance	Million operating cycles	10

Dimensional drawings

3UG46 51

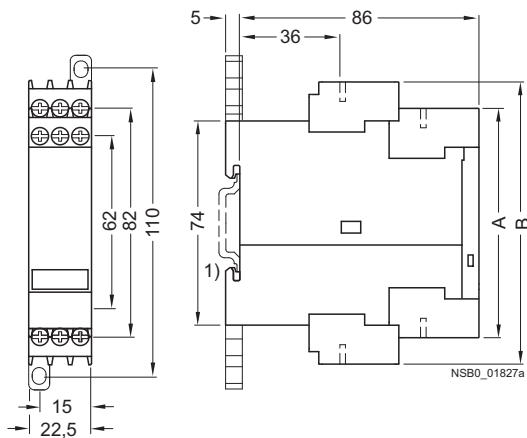

Type	3UG46 51	
	A	B

Removable terminal

Screw-type terminal	83	102
Spring-loaded terminal	84	103

1) For standard mounting rail according to EN 60715.

Monitoring Relays

3UG Monitoring Relays for Electrical and Additional Measurements

Speed monitoring

Schematics

3UG46 51

Position of the terminals

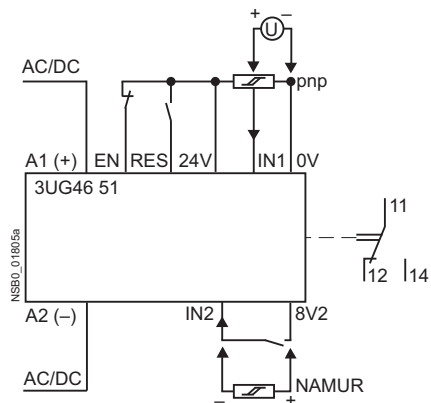

24V	IN1	0V
A1+	EN	RES
8V2	IN2	A2-
12	11	14

NSB0_011824

Circuit example without enable input

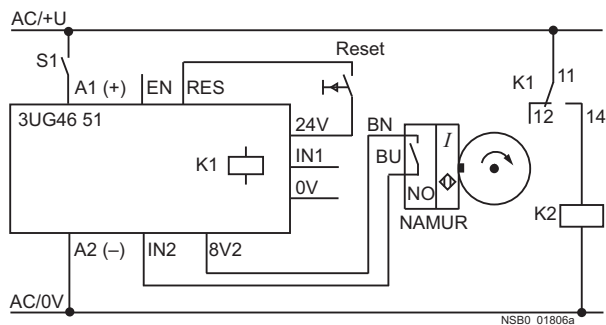

Circuit example with enable input

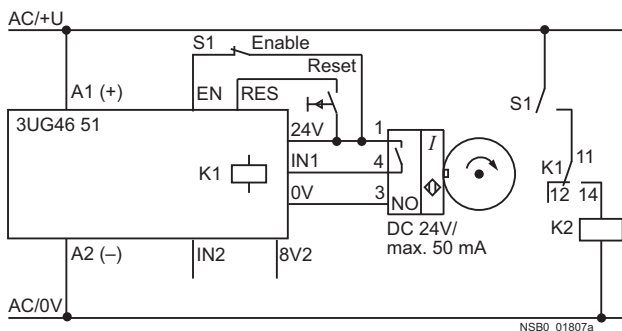

7

Monitoring Relays

3RS10, 3RS11 Temperature Monitoring Relays

General data

Overview

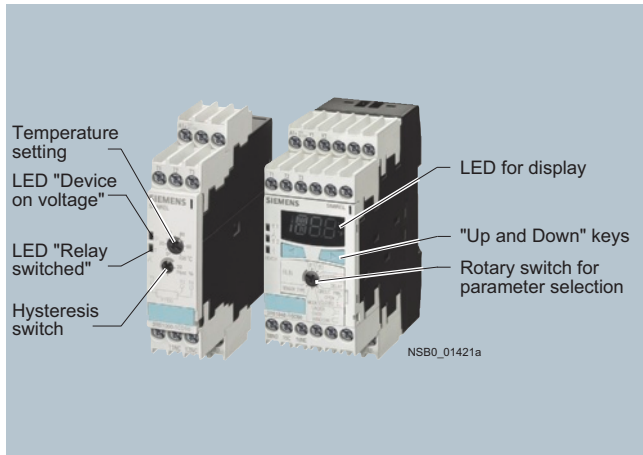

The 3RS10/3RS11 temperature monitoring relays can be used for measuring temperatures in solid, liquid and gas media. The temperature is detected by the sensor in the medium, evaluated by the device and monitored for overshoot or undershoot or for staying within an operating range (window function).

The range comprises adjustable analog units with one or two threshold values, digital units for 1 sensor, which are also a good alternative to temperature controllers for the low-end range, and digital units for up to 3 sensors which have been optimized for monitoring large motors.

Design

The temperature monitoring relays comply with:

- IEC 60947-5-1 "Low-voltage switchgear and controlgear – Electromechanical control circuit devices"
- IEC 60721-3-3 "Environmental conditions"
- EN 61000-6-4 "Basic specification for emitted interference (Industry)"
- EN 61000-6-2 "Basic specification for interference immunity (Industry)"
- EN 50042 "Designations for terminals"
- UL/CSA
- CCC

Connection of resistance-type thermometers

Two-wire measurement

When two-wire temperature sensors are used, the resistances of the sensor and wiring are added. The resulting systematic error must be taken into account when the signal evaluation unit is calibrated. A jumper must be clamped between terminals T2 and T3 for this purpose.

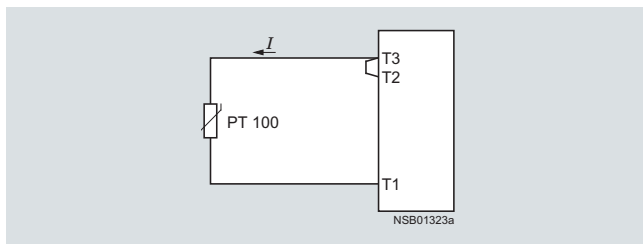

Wiring errors

The errors that are generated by the wiring comprise approximately 2.5 Kelvin/Ω. If the resistance of the cable is not known and cannot be measured, the wiring errors can also be estimated using the following table.

Temperature drift dependent on the length and cross-section of the cable with PT100 sensors and an ambient temperature of 20 °C, in K:

Cable length in m	Cross-section mm ²			
	0.5	0.75	1	1.5
0	0.0	0.0	0.0	0.0
10	1.8	1.2	0.9	0.6
25	4.5	3.0	2.3	1.5
50	9.0	6.0	4.5	3.0
75	13.6	9.0	6.8	4.5
100	18.1	12.1	9.0	6.0
200	36.3	24.2	18.1	12.1
500	91.6	60.8	45.5	30.2

Three-wire measurement

To minimize the effects of the line resistances, a three-wire circuit is often used. Using the additional cable, two measuring circuits can be formed of which one is used as a reference. The signal evaluation unit can then automatically calculate the line resistance and take it into account.

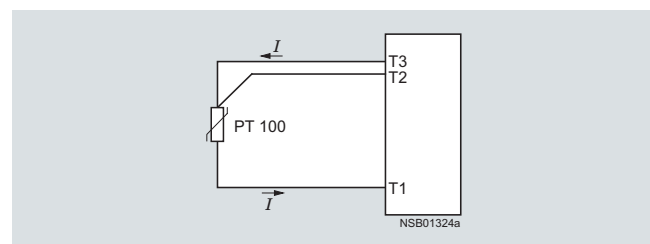

Monitoring Relays

3RS10, 3RS11 Temperature Monitoring Relays

General data

Connection of thermoelements

Based on the thermo-electrical effect, a differential temperature measurement will be performed between the measuring point and the signal evaluation unit.

This principle assumes that the signal evaluation unit knows the temperature at the clamping point (T2). For this reason, the 3RS11 temperature monitoring relay has an integral compensator that determines this comparison temperature and builds it into the result of the measurement. The thermal sensors and cables must be insulated therefore.

The absolute temperature is therefore calculated from the ambient temperature of the signal evaluation unit and the temperature difference measured by the thermoelement.

Temperature detection is therefore possible (T1) without needing to know the precise ambient temperature of the clamping point at the signal evaluation unit (T2).

The connecting cable is only permitted to be extended using connecting leads that are made from the same material as the thermoelement. If a different type of conductor is used, an error will result in the measurement.

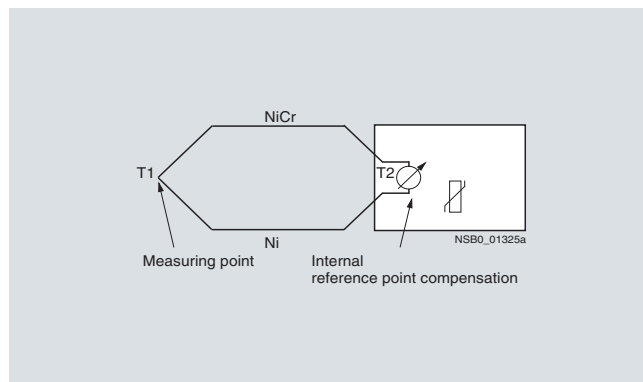

You can find more information on the Internet at:

<http://www.feldgeraete.de/76/produkte/fuw.html>

<http://www.ephy-mess.de>

or from

EPHY-MESS GmbH, see "Appendix", "External Partners"

Function

Once the temperature has reached the set threshold value ϑ_1 , the output relay K1 changes its switching state as soon as the set time t has elapsed (K2 responds in the same manner to ϑ_2). The delay time can only be adjusted with digital units (on analog units $t = 0$).

The relays return to their original state as soon as the temperature reaches the set hysteresis value.

Temperature overshoot

Closed-circuit principle

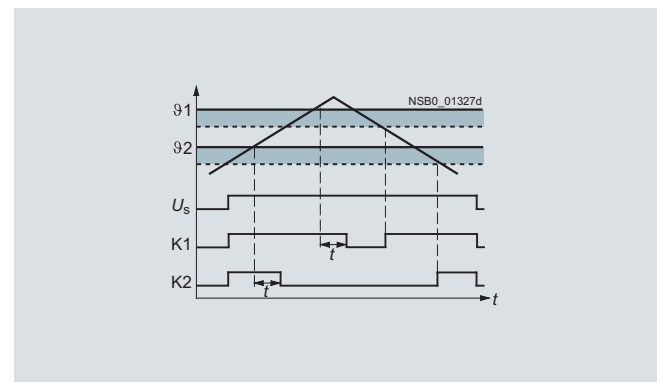

Temperature undershoot

Closed-circuit principle

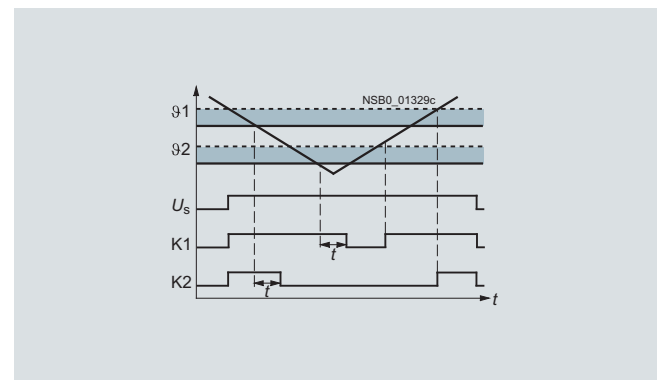

Monitoring Relays

3RS10, 3RS11 Temperature Monitoring Relays

General data

Window monitoring (digital units only)

Once the temperature has reached the upper threshold value ϑ_1 , the output relay K1 changes its switching state as soon as the set time t has elapsed. The relay returns to its original state as soon as the temperature reaches the set hysteresis value.

K2 responds in the same manner to the lower threshold value of ϑ_2 .

Closed-circuit principle

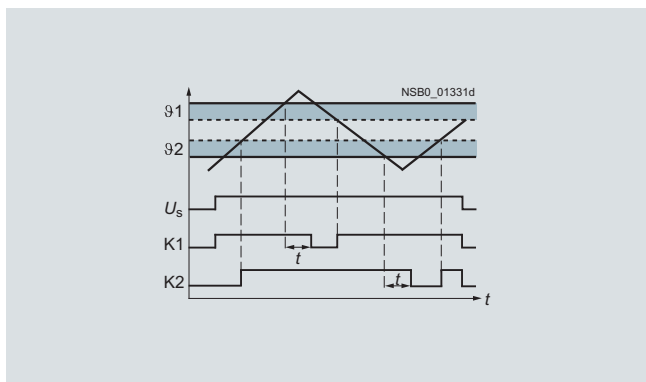

Principle of operation with memory function (3RS10 42, 3RS11 42), based on the example of temperature overshoot

Once the temperature has reached the set threshold value ϑ_1 , the output relay K1 changes its switching state as soon as the set time t has elapsed (K2 responds in the same manner to ϑ_2). The relays only return to the original state when the temperature falls below the set hysteresis value and when terminals Y3 and Y4 have been briefly jumpered.

Closed-circuit principle

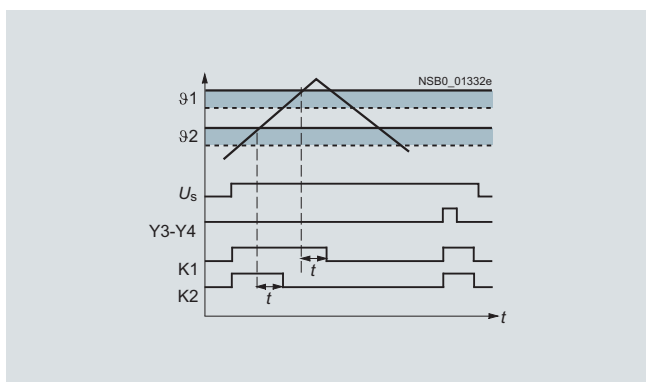

Characteristic curves

For thermoelements

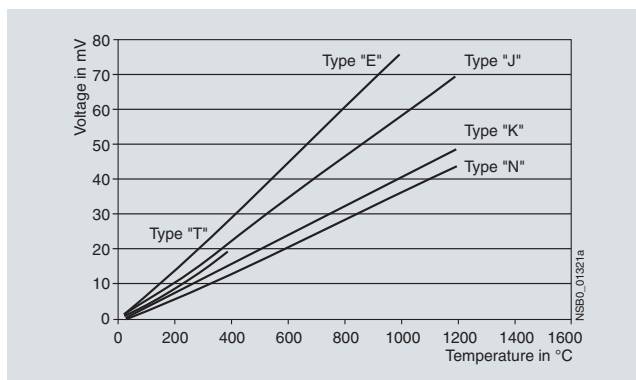

For resistance sensors

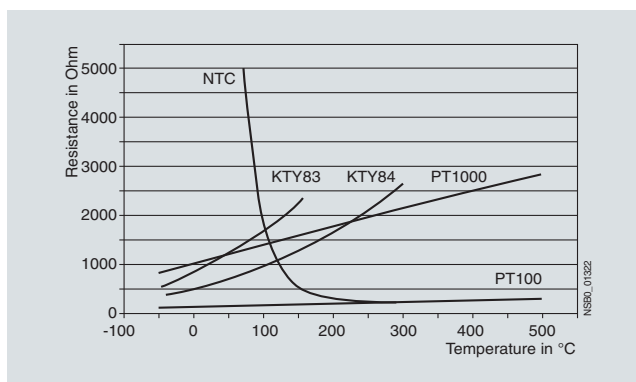

The short-circuit and open-circuit detection as well as the measuring range is limited, depending on the sensor type.

Measuring range in °C for thermoelements

Sensor type	Short-circuit	Open circuit	3RS11 40 Measuring range in °C	3RS11 42 Measuring range in °C
J	--	✓	-99 ... +999	-99 ... +1200
K	--	✓	-99 ... +999	-99 ... +1350
T	--	✓	-99 ... +400	-99 ... +400
E	--	✓	-99 ... +999	-99 ... +999
N	--	✓	-99 ... +999	-99 ... +999
S	--	✓	--	0 ... 1750
R	--	✓	--	0 ... 1750
B	--	✓	--	400 ... 1800

Measuring range in °C for resistance sensors

Sensor type	Short-circuit	Open circuit	3RS10 40/ 3RS10 41 Measuring range in °C	3RS10 42 Measuring range in °C
PT100	✓	✓	-50 ... +500	-50 ... +750
PT1000	✓	✓	-50 ... +500	-50 ... +500
KTY 83-110	✓	✓	-50 ... +175	-50 ... +175
KTY 84	✓	✓	-40 ... +300	-40 ... +300
NTC ¹⁾	✓	--	80 ... 160	80 ... 160

1) NTC type: B57227-K333-A1 (100 °C: 1.8 kΩ; 25 °C: 32.762 kΩ).

✓ = Detection possible
 -- = Detection not possible

Monitoring Relays

3RS10, 3RS11 Temperature Monitoring Relays

Relays, analogically adjustable, for 1 sensor

Overview

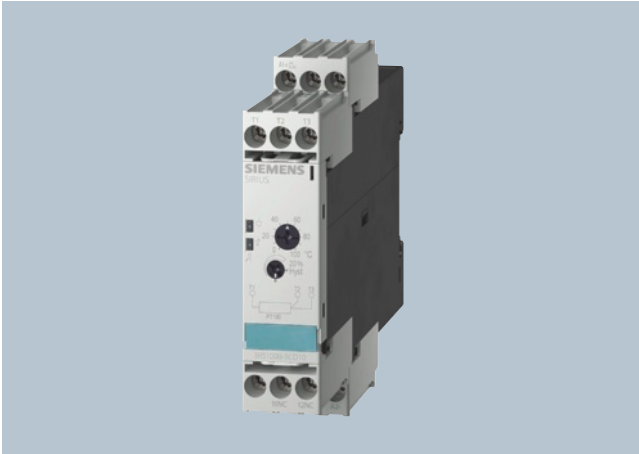



The 3RS10/3RS11 analog temperature monitoring relays can be used for measuring temperatures in solid, liquid and gas media. The temperature is detected by the sensors in the medium, evaluated by the device and monitored for overshoot or undershoot. When the threshold values are reached, the output relay switches on or off depending on the parameterization.

Monitoring Relays

3RS10, 3RS11 Temperature Monitoring Relays

Relays, analogically adjustable, for 1 sensor

Technical specifications

Type		3RS10 00	3RS10 10	3RS11 00	3RS11 01	3RS10 20	3RS10 30	3RS11 20	3RS11 21
General data									
Sensor type		PT100		TC type J	TC type K	PT100		TC type J	TC type K
Width	mm	22.5							
Operating range		0.85 ... 1.1 x U_s							
Rated power	W/VA	< 2/4							
Auxiliary circuit									
Contacts		1 NO + 1 NC				1 CO + 1 NO			
Rated operational currents I_e	A	3							
• AC-15 at 230 V, 50 Hz									
• DC-13 at:									
- 24 V	A	1							
- 240 V	A	0.1							
DIAZED fuse									
• gL/gG operational class	A	4							
Short-circuit current (at 250 V)	kA	1							
Electrical endurance	A	100 000							
AC-15 at 3A									
Mechanical endurance		3 x 10 ⁶							
Mechanical operating cycles									
Tripping units									
• Measuring accuracy at 20°C ambient temperature (T20)		Typically < ±5 % from upper limit of scale							
• Reference point accuracy	--		< ±5 K		--		< ±5 K		
• Deviations due to ambient temperature in % of measuring range		< 2		< 3		< 2		< 3	
• Hysteresis settings									
- For temperature 1		2 ... 20 % of upper limit of scale							
- For temperature 2		5 % of upper limit of scale							
Sensor circuit									
• Typical sensor circuits									
- PT100	mA	Typically 1		--		Typically 1		--	
- PT1000	mA	Typically 0.2		--		Typically 0.2		--	
• Open-circuit detection		No							
• Short-circuit detection		No							
• Three-wire conductor connection ¹⁾		Yes		-		Yes		-	
Enclosures									
Environmental influences									
Permissible ambient temperature	°C	-25 ... +60							
Permissible storage temperature	°C	-40 ... +80							
Permissible mounting positions		Any							
Degree of protection		Terminals: IP20; Cover: IP40							
acc. to EN 60529									
Rated insulation voltage U_i (degree of pollution 3)	V	300							
Connection type		 Screw terminals							
• Terminal screw		M3 (for standard screw driver size 2 and Pozidriv 2)							
• Solid	mm ²	1 x (0.5 ... 4)/2 x (0.5 ... 2.5)							
• Finely stranded with end sleeve	mm ²	1 x (0.5 ... 2.5)/2 x (0.5 ... 1.5)							
• AWG cables, solid or stranded	AWG	2 x (20 ... 14)							
• Tightening torque	Nm	0.8 ... 1.2							
Connection type		 Spring-type terminals							
• Solid	mm ²	2 x (0.25 ... 1.5)							
• Finely stranded, with end sleeves acc. to DIN 46228	mm ²	2 x (0.25 ... 1.5)							
• Finely stranded	mm ²	2 x (0.25 ... 1.5)							
• AWG cables, solid or stranded	AWG	2 x (24 ... 16)							
Vibration resistance		5 ... 26 Hz: 0.75 mm							
acc. to IEC 60068-2-6									
Shock resistance		12 shocks (half-sine 15 g/11 ms)							
acc. to IEC 60068-2-27									

¹⁾ Two-wire connection of resistance sensors with wire bridge between T2 and T3.

Monitoring Relays

3RS10, 3RS11 Temperature Monitoring Relays

Relays, analogically adjustable, for 1 sensor

Dimensional drawings

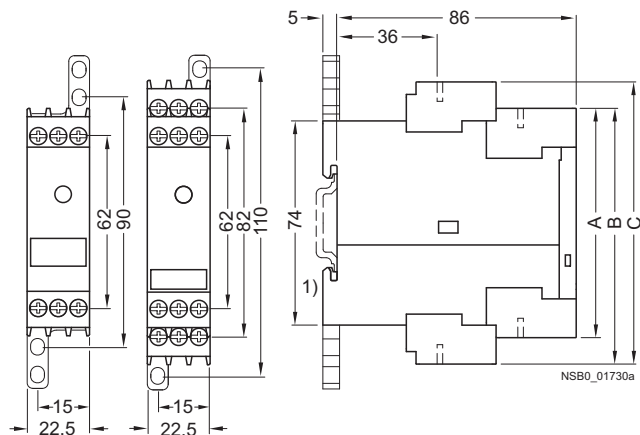

Type	3RS10 00	3RS10 10	3RS11 0 3RS11 1 3RS1. 2 3RS1. 3
	A	B	C

Removable terminal

Screw-type terminal	83	92	102
Spring-loaded terminal	84	94	103

1) For standard mounting rail according to EN 60715

Monitoring Relays 3RS10, 3RS11 Temperature Monitoring Relays

Relays, analogically adjustable, for 1 sensor

Schematics

Connection examples

3RS10 00, 3RS10 10

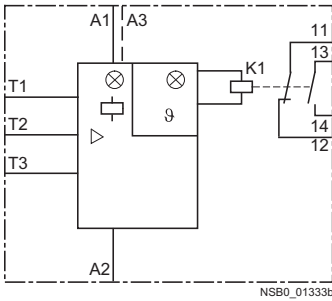

3RS11 00, 3RS11 01

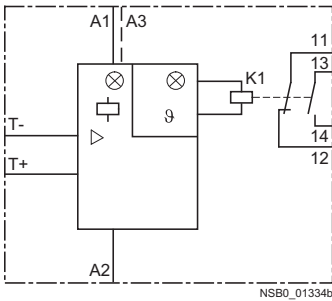

3RS10 20, 3RS10 30

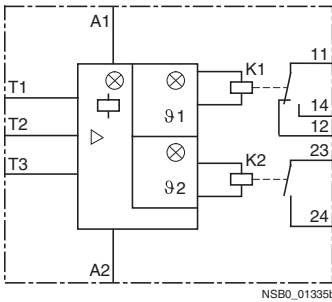

3RS11 20, 3RS11 21

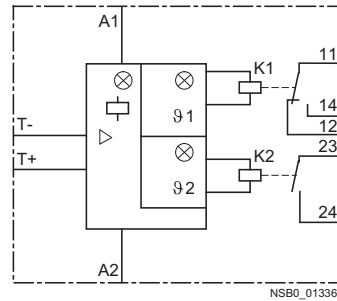

General item codes

A1= 24 V AC/DC, 230 V AC, 24 ... 240 V AC/DC

A3= 110 V AC

A2= M

K1, K2 output relays

Item code for 3RS10 00, 3RS10 10, 3RS11 00, 3RS11 01, 3RS10 20, 3RS10 30, 3RS11 20, 3RS11 21

☐ = LED: "Device connected to voltage"

91 = LED: "Relay 1 tripped"

92 = LED: "Relay 2 tripped"

T1 to T3 = Sensor connection for resistance sensor

T+/T- = Sensor connection for thermoelements

Caution!

When resistance sensors with two-wire connection are used, T2 and T3 must be jumpered.

Monitoring Relays

3RS10, 3RS11 Temperature Monitoring Relays

Relays, digitally adjustable, for 1 sensor

Overview



The 3RS10/3RS11 temperature monitoring relays can be used for measuring temperatures in solid, liquid and gas media. The temperature is detected by the sensor in the medium, evaluated by the device and monitored for overshoot or undershoot or for staying within an operating range (window function).



The relays are also an excellent alternative to temperature controllers in the low-end performance range (2- or 3-point closed-loop control).

Monitoring Relays

3RS10, 3RS11 Temperature Monitoring Relays

Relays, digitally adjustable, for 1 sensor

Technical specifications

Type		3RS10 40/3RS10 42/3RS20 40	3RS11 40/3RS21 40	3RS11 42
General data				
Width	mm	45		
Operating range	V	0.85 ... 1.1 × U _s		
Rated power	W/VA	< 4/7		
Auxiliary circuit				
Contacts		1 CO + 1 CO + 1 NO		
Rated operational currents I _e				
• AC-15 at 230 V, 50 Hz	A	3		
• DC-13 at:				
- 24 V	A	1		
- 240 V	A	0.1		
DIAZED protection	A	4		
gL/gG operational class				
Electrical endurance	A	100 000		
AC-15 at 3A				
Mechanical endurance		30 × 10 ⁶		
Mechanical operating cycles				
Tripping units				
Measuring accuracy at 20°C ambient temperature (T ₂₀)		< ±2 K, ±1 digit	< ±5 K, ±1 digit	< ±7 K, ±1 digit
Reference point accuracy		--	< ±5 K	
Deviations due to ambient temperature	%	0.05 °C per K deviation from T ₂₀		
In % of measuring range				
Measuring cycle	ms	500		
Hysteresis settings for temperature 1		1 ... 99 Kelvin, for both values		
Adjustable delay time	s	0 ... 999		
Sensor circuit				
Typical sensor circuits				
• PT100	mA	Typically 1	--	--
• PT1000/KTY83/KTY84/NTC	mA	Typically 0.2	--	--
Open-circuit detection		Yes ¹⁾	Yes	Yes
Short-circuit detection		Yes	No	No
Three-wire conductor connection		Yes ²⁾	--	--
Enclosures				
Environmental influences				
• Permissible ambient temperature	°C	-25 ... +60		
• Permissible storage temperature	°C	-40 ... +80		
• Permissible mounting positions		Any		
Degree of protection acc. to EN 60529		Terminals: IP20; Cover: IP40		
Rated insulation voltage U _i (degree of pollution 3)	V AC	300		
Connection type				
		 Screw terminals		
• Terminal screw		M3 (for standard screw driver size 2 and Pozidriv 2)		
• Solid	mm ²	1 × (0.5 ... 4)/2 × (0.5 ... 2.5)		
• Finely stranded with end sleeve	mm ²	1 × (0.5 ... 2.5)/2 × (0.5 ... 1.5)		
• AWG cables, solid or stranded	AWG	2 × (20 ... 14)		
• Tightening torque	Nm	0.8 ... 1.2		
		 Spring-type terminals		
• Solid	mm ²	2 × (0.25 ... 1.5)		
• Finely stranded, with end sleeves acc. to DIN 46228	mm ²	2 × (0.25 ... 1.5)		
• Finely stranded	mm ²	2 × (0.25 ... 1.5)		
• AWG cables, solid or stranded	AWG	2 × (24 ... 16)		
Vibration resistance acc. to IEC 60068-2-6		5 ... 26 Hz: 0.75 mm		
Shock resistance acc. to IEC 60068-2-27		12 shocks (half-sine 15 g/11 ms)		

¹⁾ Not for NTC B57227-K333-A1 (100 °C: 1.8 kΩ; 25 °C: 32.762 kΩ).

²⁾ Two-wire connection of resistance sensors with wire bridge between T2 and T3.

Monitoring Relays

3RS10, 3RS11 Temperature Monitoring Relays

Relays, digitally adjustable, for 1 sensor

Dimensional drawings

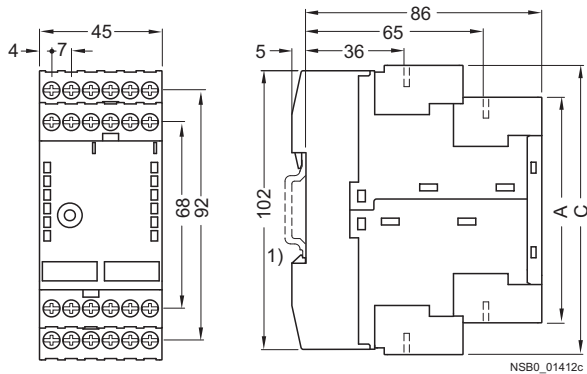

NSB0_01412c

Type	3RS10, 3RS11, 3RS20, 3RS21 digital	
	A	C

Removable terminal

Screw-type terminal	83	106
Spring-loaded terminal	84	108

1) For standard mounting rail according to EN 60715.

Schematics

Circuit examples

3RS10 40, 3RS10 42, 3RS20 40

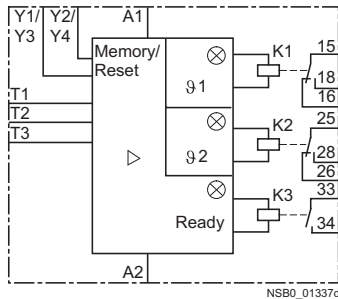

NSB0_01337d

3RS11 40, 3RS11 42, 3RS21 40

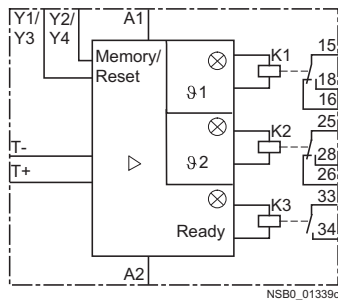

NSB0_01339c

General item codes

A1, A2, A3 terminals for rated control supply voltage

K1, K2, K3 output relay

Item code

91 = LED: "Relay 1 tripped"

92 = LED: "Relay 2 tripped"

Ready = LED: "Device is ready for operation"

T1 to T3 = Sensor connection for resistance sensor

T+/T- = Sensor connection for thermoelements

Y1/Y2 connection for memory jumper for 3RS10 40, 3RS11 40, 3RS20 40, 3RS21 40 or Y3/Y4 Reset input for 3RS10 42, 3RS11 42

Caution!

When resistance sensors with two-wire connection are used, T2 and T3 must be jumpered.

Monitoring Relays

3RS10, 3RS11 Temperature Monitoring Relays

Relays, digitally adjustable for up to 3 sensors

Overview





The 3RS10 41 temperature monitoring relays can be used for measuring temperatures in solid, liquid and gas media. The temperature is detected by the sensor in the medium, evaluated by the device and monitored for overshoot or undershoot or for staying within an operating range (window function). The evaluation unit can evaluate up to 3 resistance sensors at the same time and is specially designed for monitoring motor windings and bearings.

Monitoring Relays

3RS10, 3RS11 Temperature Monitoring Relays

Relays, digitally adjustable for up to 3 sensors

Technical specifications

Type		3RS10 41
General data		
Width	mm	45
Operating range	V	0.85 ... 1.1 × U_g
Rated power	WVA	< 4/7
Auxiliary circuit		
Contacts		1 CO + 1 CO + 1 NO
Rated operational currents I_e		
• AC-15 at 230 V, 50 Hz	A	3
• DC-13 at:		
- 24 V	A	1
- 240 V	A	0.1
DIAZED fuse		
• gL/gG operational class	A	4
Electrical endurance AC-15 at 3A	A	100 000
Mechanical endurance Mechanical operating cycles		30 × 10 ⁶
Tripping units		
Measuring accuracy at 20°C ambient temperature (T20)		< ±2 K, ±1 digit
Deviations due to ambient temperature In % of measuring range	%	0.05 per K deviation from T20
Measuring cycle	ms	500
Hysteresis settings for temperature 1		1 ... 99 Kelvin, for both values
Adjustable delay time	s	0 ... 999
Sensor circuit		
Typical sensor circuits		
• PT100	mA	Typically 1
• PT1000/KTY83/KTY84/NTC	mA	Typically 0.2
Open-circuit detection		Yes ¹⁾
Short-circuit detection		Yes
Three-wire conductor connection		Yes ²⁾
Enclosures		
Environmental influences		
• Permissible ambient temperature	°C	-25 ... +60
• Permissible storage temperature	°C	-40 ... 80
• Permissible mounting positions		Any
Degree of protection acc. to EN 60529		Terminals: IP20; Cover: IP40
Rated insulation voltage U_i (degree of pollution 3)	V AC	300
Connection type		 Screw terminals
• Terminal screw		M3 (for standard screw driver size 2 and Pozidriv 2)
• Solid	mm ²	1 × (0.5 ... 4)/2 × (0.5 ... 2.5)
• Finely stranded with end sleeve	mm ²	1 × (0.5 ... 2.5)/2 × (0.5 ... 1.5)
• AWG cables, solid or stranded	AWG	2 × (20 ... 14)
• Tightening torque	Nm	0.8 ... 1.2
Connection type		 Spring-type terminals
• Solid	mm ²	2 × (0.25 ... 1.5)
• Finely stranded, with end sleeves acc. to DIN 46228	mm ²	2 × (0.25 ... 1.5)
• Finely stranded	mm ²	2 × (0.25 ... 1.5)
• AWG cables, solid or stranded	AWG	2 × (24 ... 16)
Vibration resistance acc. to IEC 60068-2-6		5 ... 26 Hz: 0.75 mm
Shock resistance acc. to IEC 60068-2-27		12 shocks (half-sine 15 g/11 ms)

¹⁾ Not for NTC B57227-K333-A1 (100 °C: 1.8 kΩ; 25 °C: 32.762 kΩ).

²⁾ Two-wire connection of resistance sensors with wire bridge between T2 and T3.

Monitoring Relays 3RS10, 3RS11 Temperature Monitoring Relays

Relays, digitally adjustable for up to 3 sensors

Dimensional drawings

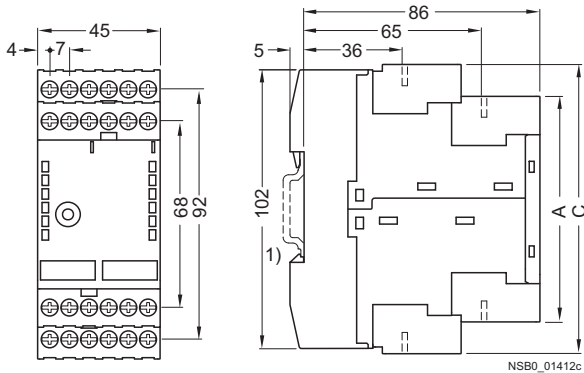

NSB0_01412c

Type	3RS10, 3RS11, 3RS20, 3RS21 digital	
	A	C

Removable terminal

Screw-type terminal	83	106
Spring-loaded terminal	84	108

1) For standard mounting rail according to EN 60715.

Schematics

Circuit example

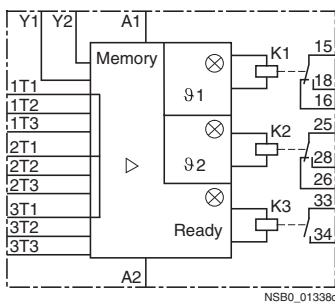

NSB0_01338c

General item codes

A1, A2, A3 terminals for rated control supply voltage

K1, K2, K3 output relay

Item codes for 3RS10 41

91 = LED: "Relay 1 tripped"

92 = LED: "Relay 2 tripped"

Ready = LED: "Device is ready for operation"

1T1 to 1T3 = Sensor connection for resistance sensor 1

2T1 to 2T3 = Sensor connection for resistance sensor 2

3T1 to 3T3 = Sensor connection for resistance sensor 3

Y1/Y2 connection for memory jumper

Caution!

When resistance sensors with two-wire connection are used, T2 and T3 must be jumpered.

Monitoring Relays

3RN1 Thermistor Motor Protection

For PTC sensors

Overview

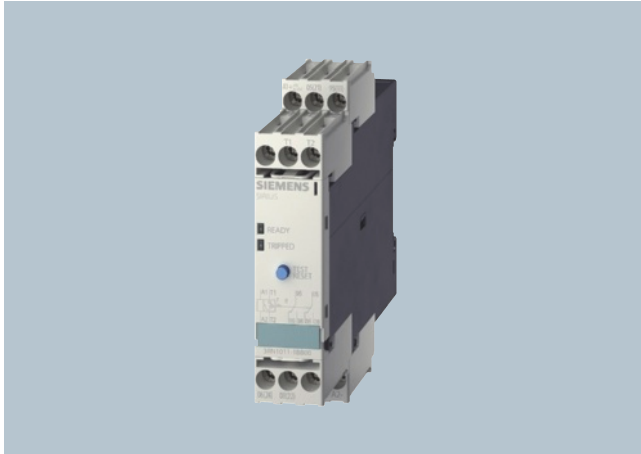

Thermistor motor protection devices are used for direct monitoring of the motor winding temperature. For this purpose, the motors are equipped with temperature-dependent resistors (PTC) that are directly installed in the motor winding and abruptly change their resistance at their limit temperature.

Design

The 3RN1 tripping units are suitable for use in any climate and finger-safe according to EN 50274. They comply with:

- EN 60947-8
- EN 61000-6-2 and EN 61000-6-4, "Electromagnetic compatibility of I&C equipment in industrial process engineering"

The terminals of the auxiliary contacts are designated in accordance with EN 50005.

The 3RN1 tripping units are suitable for snap-on mounting onto TH 35 standard mounting rails according to EN 60715 or for screw fixing using an adapter (Accessories).

Any mounting position is possible.

For devices with the "Manual RESET" function, the test function can be activated and a trip simulated by pressing the blue Test/RESET button for longer than 2 seconds.

If a Type A temperature sensor is connected to a Type A tripping unit, compliance with the operating temperatures is assured (on pick-up and reset) according to IEC 60034-11-2 and EN 60947-8.

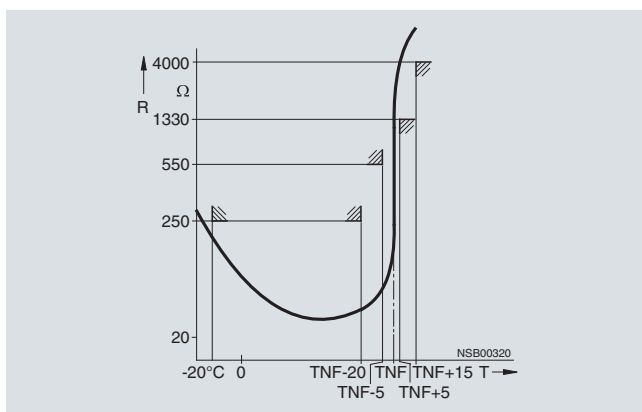

The characteristic curves of the Type A temperature sensors are described in EN 60947-8, DIN 44081 and DIN 44082.

Use in areas subject to explosion hazard for gases

All devices are approved for Equipment Group II, Category (2) in Area "G" (areas that contain explosive gases, vapor, spray and air mixtures).

With PTB 01 ATEX 3218 ex II (2) G, compliance with 94/9 EC directive Appendix II is confirmed. The safety devices must be selected with suitable settings for the safe operation of motors of the "Increased safety" (EEx e) and "Flameproof enclosure" (EEx d) types of protection and are used outside the area subject to explosion hazard.

PTB 01 ATEX 3218 ex II (2) G

The increased danger in areas subject to explosion hazard demands careful analysis of the operating manual, the safety and commissioning instructions and the standard (EN 60079-14) for electronic equipment in areas subject to gas explosion hazards.

A risk analysis must be performed for the complete plant or machine. If this risk analysis results in a minimal potential for danger (Safety Category 1), all 3RN1 TMS tripping units can be implemented taking into account the safety notes. In the case of plants or machines with a high potential risk, versions with integrated short-circuit detection in the sensor circuit are necessary.

Use in areas subject to explosion hazard for dust

PTB 01 ATEX 3218 ex II (2) GD

3RN10 11-.B/-G, 3RN10 12-.B/-G and 3RN10 13-...0 tripping units can be used as protective devices for motors in areas subject to gas explosion hazard for protection against impermissible overheating due to overload. If the ATEX marking has the extension "D:=Dust", these units can also be used as protective devices for motors in areas subject to dust explosion hazard (EN 50281-1-1).

Additional information is provided in the EC type test certificate which can be obtained from the Internet. The units comply with the requirements of the following classes:

Device	Class
3RN10 00, 3RN10 10, 3RN10 11-.C, 3RN10 12-.C, 3RN10 22, 3RN10 62	EN 954-1: Category 1
3RN10 11-.B, 3RN10 11-.G, 3RN10 12-.B, 3RN10 12-.G, 3RN10 13	EN 954-1: Category 2

Monitoring Relays

3RN1 Thermistor Motor Protection

For PTC sensors

The measuring circuit leads must be routed as separate control cables. It is not permitted to use cores from the supply line of the motor or any other main supply cables. If extreme inductive or capacitive interference is expected as a result of power lines routed in parallel, shielded control cables must be used.

Cable routing

Maximum cable length for sensor circuit cables

Conductor cross-section	Cable length for tripping units	
	Without short-circuit detection 3RN10 00, 3RN10 10 3RN10 11-.C, 3RN10 12-.C 3RN10 22, 3RN10 62	With short-circuit detection ¹⁾ 3RN10 11-.B/-G 3RN10 12-.B/-G 3RN10 13
mm ²	m	m
2.5	2 x 2800	2 x 250
1.5	2 x 1500	2 x 150
0.5	2 x 500	2 x 50

¹⁾ A short-circuit in the sensor circuit will be detected up to this maximum cable length.

Notes:

Tripping of the thermistor motor protection relay even in combination with a converter must directly result in disconnection. This must be implemented with circuitry.

Mounting and installation must only be performed by qualified personnel who observe the applicable regulations! For mounting, use mounting instruction No.: 3ZX1012-0RN10-1AA1.

The 3RN10 is not intended for installation in hazardous areas. For installation in areas subject to explosion hazards, the 3RN10 must be enclosed in a flameproof casing.

For tripping units with a 24 V AC/DC control voltage, electrical separation must be secured with a battery network or a safety transformer according to DIN VDE 0551.

When tripping units with Auto-RESET function are used, a reset is performed automatically after the cooling time has expired. It must be ensured by means of an external interlock (latching with a separate ON and OFF button) that the machine to be monitored does not start up again spontaneously.

Units with the "Auto-RESET" function must not be used in applications in which the unexpected restart can lead to personal injury or property damage.

In the case of tripping units without short-circuit detection, during commissioning or after modifications or maintenance work (assembly, disassembly) on the equipment, the sensor resistance must be measured using a suitable measuring device. For resistances of < 50 Ω the sensor circuit must be checked for a short-circuit.

If 3RN10 00 units are used to protect EEx e motors, separate monitoring of the control voltage is recommended because there is no Ready LED to indicate connection to the supply voltage.

If 3RN10 13-.BW01 units are used to protect EEx e motors, separate monitoring of the control voltage is recommended because the switching state of the auxiliary contacts does not change if the control voltage fails (use of a bistable relay is recommended).

Before commissioning, the effectiveness of the protection function must be checked.

Function

The 3RN1 tripping units operate in accordance with the closed-circuit principle and therefore monitor themselves for open circuit (except: warning output in the case of 3RN10 22). A momentary voltage failure of less than 50 ms does not change the status of the auxiliary contacts. The 3RN10 11, 3RN10 12 and 3RN10 13 units with 2 changeover contacts are also equipped with short-circuit detection in the sensor circuit. The unit will trip in the event of a short-circuit in the sensor circuit (resistance in sensor circuit < 20 Ω).

All tripping units (except for 24 V AC/DC) feature electrical separation between the control circuit and the sensor circuit.

3RN10 00 compact tripping units

The compact tripping unit is equipped with a red LED (TRIPPED) for the tripped indicator and a changeover contact.

After the unit has tripped, it is automatically reset once the thermistors have cooled down. The root of the changeover contact is connected to the control voltage (95 is connected to terminal A1).

This unit is particularly suitable in circuits in which the control circuit and signaling circuit have the same potential, e. g. in local control cabinets.

3RN10 10, 3RN10 11, 3RN10 12, 3RN10 13 standard tripping units

The standard devices are equipped with two LEDs (READY and TRIPPED) for an operating and tripped display and are available with either 1 NO + 1 NC or with 2 CO contacts. They are available depending on the version with automatic RESET (3RN10 10), manual/remote RESET (3RN10 11) or manual/automatic and remote RESET (3RN10 12 and 3RN10 13). Remote RESET can be achieved by connecting an external pushbutton with a normally-open function to terminals Y1 and Y2. If terminals Y1 and Y2 are bridged, tripping will be followed by an automatic RESET.

The 3RN10 11, 3RN10 12 and 3RN10 13 units with 2 COs also have short-circuit monitoring in the sensor circuit.

The 3RN10 12 and the 3RN10 13 are non-volatile. This means that even if the control supply voltage fails, a trip preceding it will be latched.

In the case of the 3RN10 13 tripping unit, tripping due to a short-circuit in the sensor circuit will be indicated by a flashing red LED. The monostable version also indicates open circuit in the sensor circuit by flashing of the red LED.

3RN10 22 "Warning and disconnection" tripping units

Two sensor circuits can be connected to one 3RN10 22 tripping unit that acts on one output relay with 1 NO contact for warning and 1 CO for disconnection. Temperature sensors with different rated response temperatures TNF are used to implement the "Warning" and "Disconnection" functions. When the "Warning" sensor circuit responds, a yellow LED is lit and when the "Disconnection" circuit responds, a red LED is lit.

The sensor circuits have a different reset response and operating behavior:

"Warning" (terminals 2T1, T2) only features automatic RESET and uses the open-circuit principle.

"Disconnection" (terminals 1T1, T2) can be changed from manual RESET to automatic RESET by linking terminals Y1 and Y2. Remote RESET is implemented by connecting an external pushbutton with a normally-open function.

Monitoring Relays

3RN1 Thermistor Motor Protection

For PTC sensors

3RN10 62 tripping units for multiple motor protection

Up to 6 sensor circuits can be connected to the 3RN10 62 tripping unit, all of which act on one output relay. The simultaneous protection of several motors (up to 6) is an advantage for multi-motor drives (e. g. if one motor is overloaded, all the other motors of the drive will be shut down). Apart from the red LED "TRIPPED", which signals the switching state of the tripping unit, a LED is assigned to each sensor circuit which indicates the sensor circuit that has responded. Unused sensor circuits must be short-circuited.

The reset response of the 3RN10 62 tripping units can be changed from manual RESET to automatic RESET by linking terminals Y1 and Y2. Remote RESET is implemented by connecting an external pushbutton with a normally-open function.

Response of the tripping units in the event of control voltage failure

Behavior	Monostable	Non-volatile, monostable	Bistable
	3RN10 00 3RN10 10 3RN10 11	3RN10 12 3RN10 13-...0 3RN10 22 3RN10 62	3RN10 13-...01
In case of failure of the control voltage	Device trips	Device trips	No change in switching state of the auxiliary contacts
In case of return of the control voltage without a preceding tripping operation	Device resets	Device resets	No change in switching state of the auxiliary contacts
In case of return of the control voltage after a preceding tripping operation	Device resets	The device remains tripped	No change in switching state of the auxiliary contacts

Protective separation

All circuits (outputs, control circuits, sensor and RESET circuits) of the 3RN10 13-1BW10 and 3RN10 13-1GW10 multifunction tripping units (wide voltage range, monostable output relay and screw connection) are safely separated from each other up to a rated voltage of 300 V according to DIN VDE 0100-410 (IEC 60364-4-41) and EN 60947-1.

Function diagrams

3RN10 00/3RN10 10 (Auto-RESET)

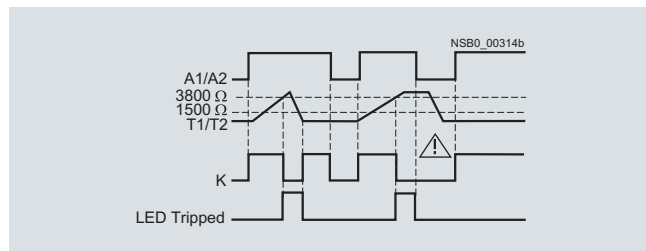

1) For versions with 2 CO and short-circuit detection in the sensor circuit see function diagram 3RN10 13.

3RN10 11¹⁾

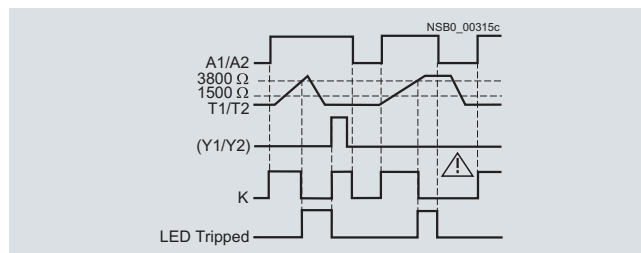

3RN10 13-...01

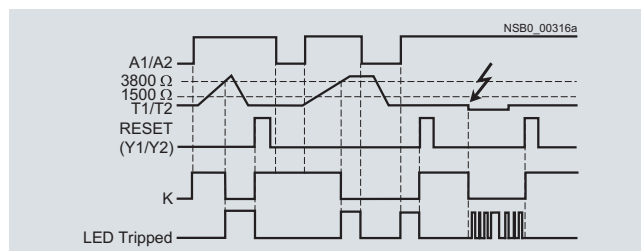

3RN10 12¹⁾/3RN10 22/3RN10 62

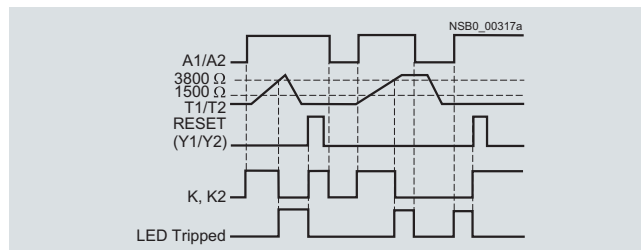

3RN10 13-...0

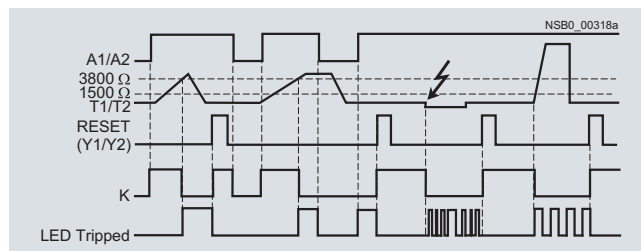

3RN10 22 only

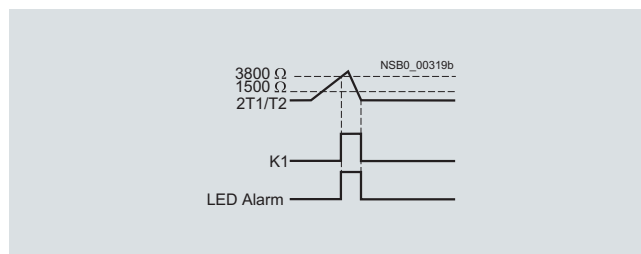



Monitoring Relays

3RN1 Thermistor Motor Protection

For PTC sensors

Technical specifications

Type	Compact units		Standard devices				Multi-function units	Warning + tripping	Multiple motor protection	
	3RN10 00	3RN10 10	3RN10 11	3RN10 12	3RN10 13	3RN10 22				3RN10 62
General data										
Width	mm	22.5							45	
Number of connectable sensor circuits		1						2	6	
Response in the event of control voltage failure		1)								
Manual RESET		No				Yes				
Automatic RESET		Yes		No		Yes				
Remote RESET		No		Yes ²⁾		Yes				
TEST pushbutton		No				Yes				
Short-circuit detection for sensor circuit		No		Yes (for 2 CO units)		Yes		No		
Short-circuit and open-circuit indication		No				Yes ³⁾		No		
Warning and disconnection in one unit		No						Yes		No
Tripping units										
Rated insulation voltage U_i (degree of pollution 3)	V	300								
Permissible ambient temperature	°C	-25 ... +60								
Permissible storage temperature	°C	-40 ... +80								
EMC tests		EN 61000-6-2, EN 61000-6-4								
Degree of protection acc. to EN 60529		IP20								
Connection type		 Screw terminals								
• Terminal screw		M3 (for standard screw driver size 2 and Pozidriv 2)								
• Solid	mm ²	1 x (0.5 ... 4)/2 x (0.5 ... 2.5)								
• Finely stranded with end sleeve	mm ²	1 x (0.5 ... 2.5)/2 x (0.5 ... 1.5)								
• AWG cables solid or stranded	AWG	2 x (20 ... 14)								
• Tightening torque	Nm	0.8 ... 1.2								
Connection type		 Spring-type terminals								
• Solid	mm ²	2 x (0.25 ... 1.5)								
• Finely stranded with end sleeves acc. to DIN 46228	mm ²	2 x (0.25 ... 1.5)								
• Finely stranded	mm ²	2 x (0.25 ... 1.5)								
• AWG cables solid or stranded	AWG	2 x (24 ... 16)								
Sensor circuit										
Measuring circuit load at $R_F \leq 1.5$ mW		≤ 5								
Voltage in sensor circuit at $R_F \leq 1.5$ mW	V	≤ 2								
Response temperature (depends on sensor)	°C	60 ... 180								
Coupling time (depends on sensor)	s	About 5								
Summation PTC resistance R_F (per sensor loop)	k Ω	≤ 1.5								
Response value	k Ω	3.4 ... 3.8								
Return value	k Ω	1.5 ... 1.65								
Response tolerance	°C	± 6								

1) See Catalog LV 1, Selection and ordering data.

2) Remote RESET possible by disconnecting control voltage.

3) Open circuits are only indicated by monostable versions (3RN10 13-...0).

Monitoring Relays

3RN1 Thermistor Motor Protection

For PTC sensors

Type	Compact units				Standard devices		Multi-function units	Warning + tripping	Multiple motor protection
	3RN10 00	3RN10 10	3RN10 11	3RN10 12	3RN10 13	3RN10 22			
Control circuit									
Rated control supply voltage U_s	1)								
Operating range	0.85 ... 1.1 x U_s								
• 110/230 V AC	0.85 ... 1.1 x U_s								
• 24 ... 240 V AC/DC	0.85 ... 1.2 x U_s for DC operation, 0.85 ... 1.1 x U_s for AC operation								
• 24 V AC/DC									
Rated power	< 2								
• AC/DC	W								
Max. mains buffering time	ms	50							
Auxiliary circuit									
Conventional thermal current I_{th}	A	5							
Rated operational current I_e									
• AC-15 240 V	A	3							
• DC-13 24 V	A	1							
DIAZED fuse	A	6 ²⁾							
CSA and UL rated data, control circuit									
Rated control voltage 50/60 Hz									
• AC	V	300							
• DC	V	300							
Switching capacity	R 300/B 300								
Protective separation up to 300 V acc. to DIN 60947-1	--				3RN10 13-1BW10, 3RN10 13-1GW10		--		

1) See Catalog LV 1, Selection and ordering data.

2) $I_n > 1$ kA weld-free according to EN 60947-5-1.

Dimensional drawings

3RN1 with 1 ... 2 sensor circuits

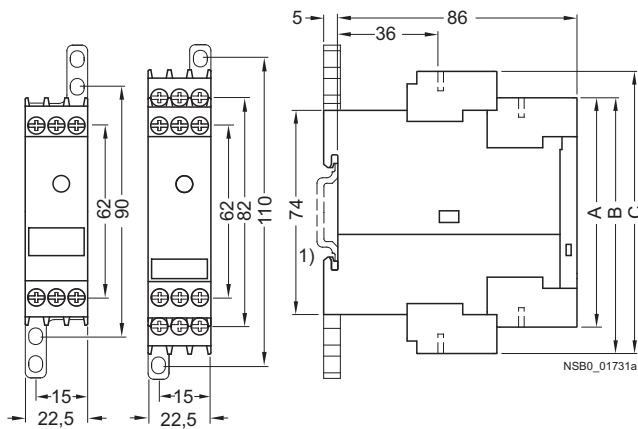

3RN10 62

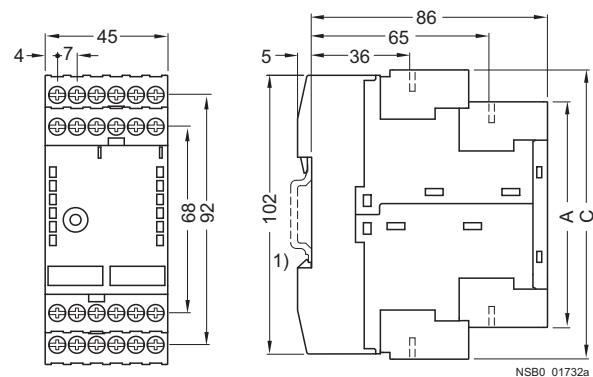

Type	3RN10 00	3RN10 10-C	3RN10 10-B 3RN10 10-G 3RN10 11 3RN10 12 3RN10 13 3RN10 22
	A	B	C

Removable terminal

Screw-type terminal	83	92	102
Spring-loaded terminal	84	94	103

1) For standard mounting rail according to EN 60715.

Type	3RN10 62	
	A	C

Removable terminal

Screw-type terminal	83	106
Spring-loaded terminal	84	108

1) For standard mounting rail according to EN 60715.

Monitoring Relays 3RN1 Thermistor Motor Protection

For PTC sensors

Schematics

Circuit diagrams

Illustrated with control voltage applied

Illustrated with control voltage not applied

Illustrated with control voltage applied

Illustrated with control voltage not applied

General item codes

A1, A2, A3 Connections of the control voltage
 N Amplifier
 T/R TEST/RESET button
 Y1, Y2 Connections for remote RESET (jumped = Auto-RESET)
 ↑ The double arrow indicates an operating state which deviates from the standard representation of the contact according to DIN 40900, Part 7 (Here: Position of the contacts when control voltage is applied to terminals A1 and A2)

Item codes for 3RN10

H1 "READY" LED
 H2 "TRIPPED" LED
 K Output relay
 T1, T2 Connections of the sensor loop

Item codes for 3RN10 22

H1 "READY" LED
 H2 "TRIPPED" LED
 H3 "ALARM" LED
 K1 Output relay for warning threshold ("ALARM" LED)
 K2 Output relay for disconnection ("TRIPPED" LED)
 1T1 and T2 Connections of the sensor loop
 2T1 and T2 Connections of the sensor loop

⚠ Important!

Close unconnected sensor circuits.

Item codes for 3RN10 62

H1 to H6 LED for the tripped sensor loop
 H7 "READY" LED
 H8 "TRIPPED" LED
 K Output relay
 1T1, 1T2 Connections of the 1st sensor loop
 6T1, 6T2 Connections of the 6th sensor loop

⚠ Important!

Close unconnected sensor circuits.

3RN10 00, 1 CO

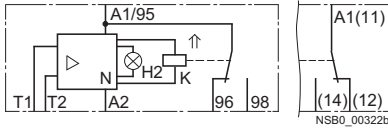

3RN10 10, 1 NO + 1 NC

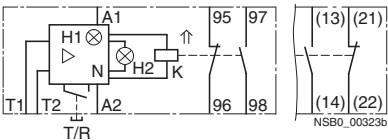

3RN10 10, 2 COs

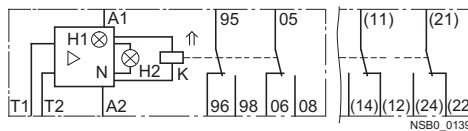

3RN10 11¹⁾, 1 NO + 1 NC

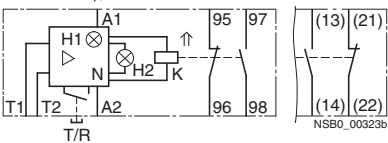

3RN10 11, 2 COs

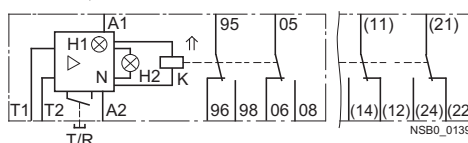

3RN10 12¹⁾, 1 NO + 1 NC

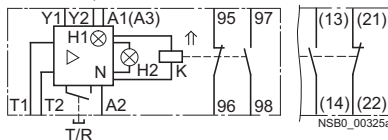

3RN10 12, 2 COs

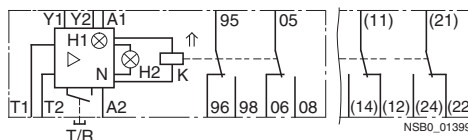

3RN10 13-...0 (monostable)

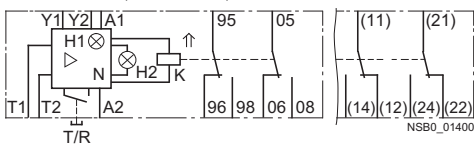

3RN10 13-...1 (bistable)

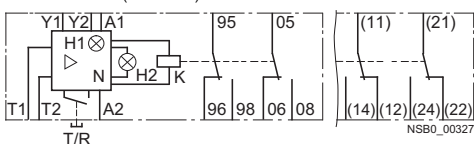

3RN10 22

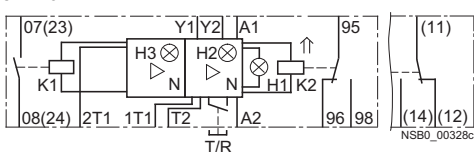

3RN10 62

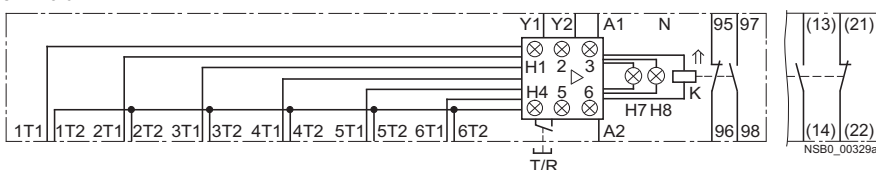

¹⁾ For units with combination voltages 230 V/110 V AC (3RN10 11-.CK00 and 3RN10 12-.CK00) the following applies:
 A1 and A2: 230 V AC, A3 and A2: 110 V AC.

3TK28 Safety Relays

General data

Overview

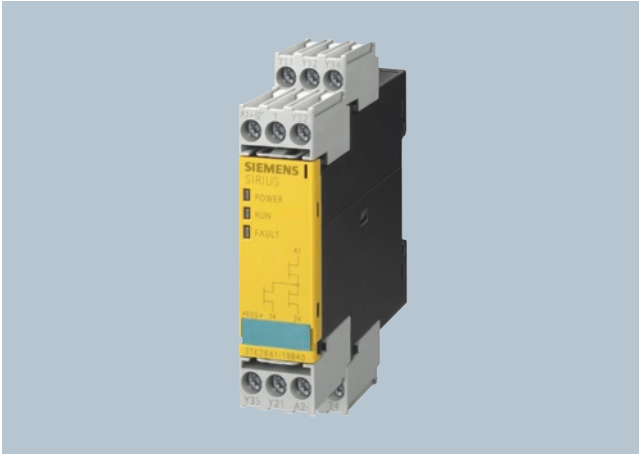

SIRIUS safety relays are the key modules of a consistent and cost-effective safety chain. Be it EMERGENCY-STOP disconnection, protective door monitoring or the protection of presses or punches – with SIRIUS safety relays every safety application can be implemented to optimum effect in terms of engineering and price.

SIRIUS safety relays provide numerous safety-related functions:

- Monitoring the safety functions of sensors
- Monitoring the sensor cables
- Monitoring the correct operation of the safety relay
- Monitoring the actuators (contactors) in the shutdown circuit
- Safety-oriented disconnection when dangers arise

SIRIUS safety relays meet the highest requirements (Category 4) according to EN 954-1 and achieve the highest safety integrity level (SIL 3) according to IEC 61508.

Function**SIRIUS safety relays and the safety chain**

A safety chain normally comprises the following functions: sensing, evaluating and shutdown.

Sensing

The detection of a safety requirement, e. g. when an EMERGENCY-STOP is actuated or someone enters a hazardous area which is protected by sensors such as light arrays or laser scanners.

Evaluating

The evaluation of a safety requirement and the reliable initiation of a reaction, e. g. shutting down the enabling circuits.

Shutdown

The shutting down of hazards, e. g. a power supply, using the downstream contactors. SIRIUS safety relays are active in the evaluating and shutdown links of this safety chain.

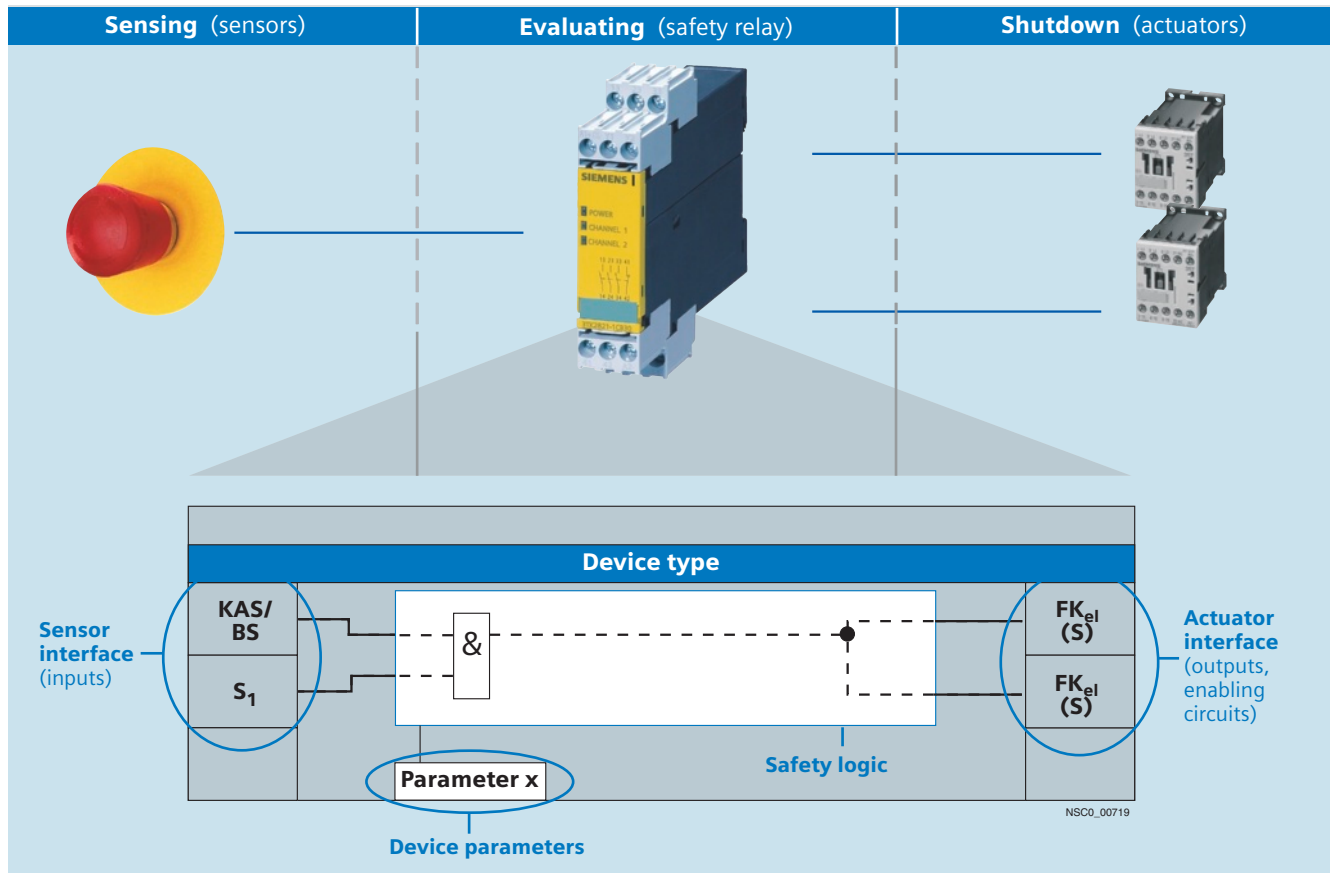

The inputs of the device (number and type) are portrayed in the sensor interface. The safety logistics is shown at the center. The mode of operation of the device and the way the inputs act on the outputs are explained with the help of this safety logistics. The type and number of enabling circuits or signaling outputs are shown in the actuator interface, and the setting options (parameters) of the device are shown at the lower edge of the graphic.

Notes on the function diagrams on pages 7/118 to 7/143

In the interest of simplicity, the function diagrams show only the inputs and outputs which are required to explain the safety function. The power supply inputs and the sensors and actuators which can be connected to the interfaces are disregarded because they are not relevant for illustrating the function.

The legends explain the meaning of the symbols.

3TK28 Safety Relays

With electronic enabling circuits

Design

The solid-state safety relays can be used in EMERGENCY-STOP devices to EN 418 and in safety circuits to EN 60204-1 (11.98), for example, for moving covers and protective doors. Depending on the device type and the external circuit, the maximum category that can be achieved is Category 4 of EN 954-1 or SIL 3 according to IEC 61508.

Mounting

For snap-on mounting on 35 mm standard mounting rail according to EN 60715. Screw fixing is also possible for the devices by means of 2 additional 3RP19 03 push-in lugs.

Function

Basic units

3TK28 40

The 3TK28 40 has one sensor input S1 and two solid-state enabling circuits. If the signal is no longer applied to the sensor input, the enabling circuits are disconnected immediately.

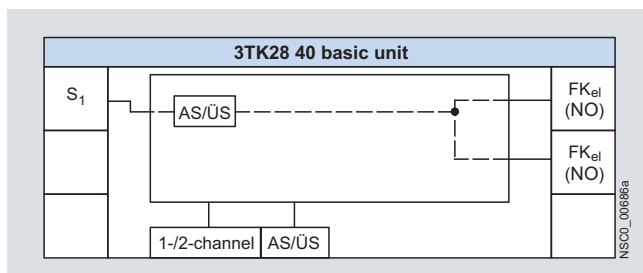

3TK28 41 and 3TK28 42

The 3TK28 41 and 3TK28 42 each has one sensor input S1 and one cascading input KAS/BS as well as two solid-state enabling circuits (2 x instantaneous or 1 x instantaneous and 1 x with delay). If the signal is no longer applied to either of the two inputs, the enabling circuits are isolated immediately or according to the set delay time. Autostart or monitored start can be selected in the parameterization.

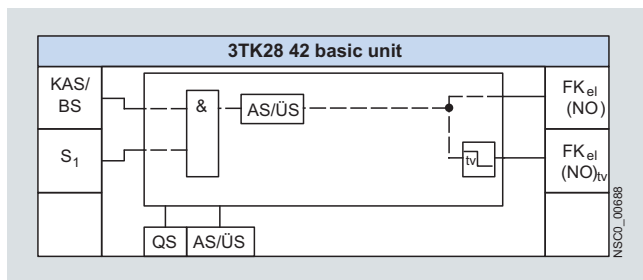
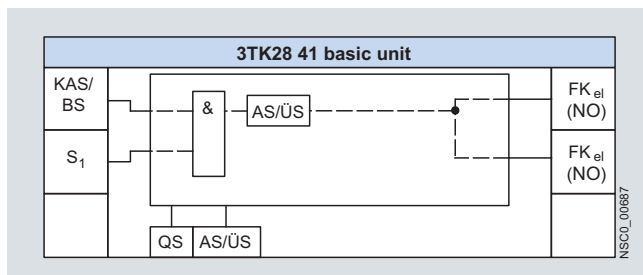

Legend

Sensor interface

KAS/BS: Cascading input or normal switching duty.
Normal switching duty: Connection of a PLC output for example. The enabling circuits and hence the connected loads can then be operated by the machine control.
The safety function is on a higher level.
S_x: Sensor input

Safety logic

AS/ÜS: Automatic or monitored start depending on the parameterization



Time delay, OFF-delay

Parameters

AS/ÜS: Automatic or monitored start depending on the parameterization
QS: With or without crossover monitoring
1-/2-channel: One-channel / two-channel sensor connection

Actuator interface

FK_{el}: Enabling circuit, solid-state (non-floating)
NO: NO contact
NO_{tv}: NO contact, time-delayed

Multi-function units

3TK28 45-.HB.. "Monitored start and autostart"

The 3TK28 45-.HB.. has two sensor inputs (S_1 with monitored start, S_2 with autostart), a cascading input (KAS/BS with autostart) and a changeover input (key-operated switch). On the output side are two relay enabling circuits, two solid-state enabling circuits and a solid-state signaling output.

Normal operation

In normal operation (key-operated switch "OFF"), all enabling circuits are activated. All inputs are "AND"-interconnected and act simultaneously on all enabling circuits, some time-delayed.

Service operation

In service operation (key-operated switch "ON"), only two of the four enabling circuits are activated. In this case the sensor input S_2 (e. g. protective door) has no function. The hazard area can be entered because the hazardous movement is switched off by means of the two inactive enabling circuits. The sensor input S_1 and the cascading input KAS/BS still act on the active enabling circuits.

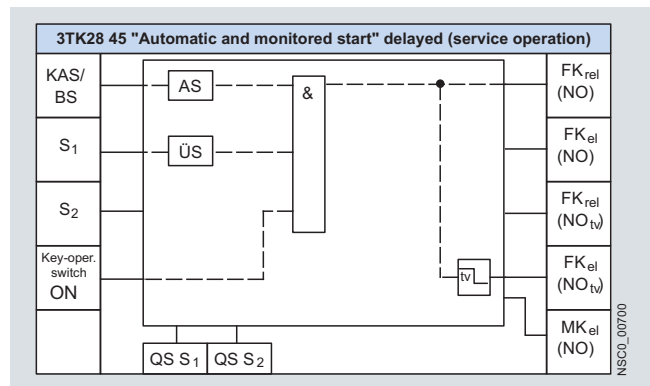
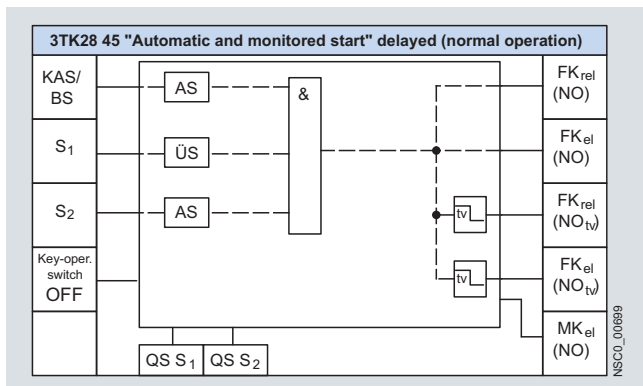
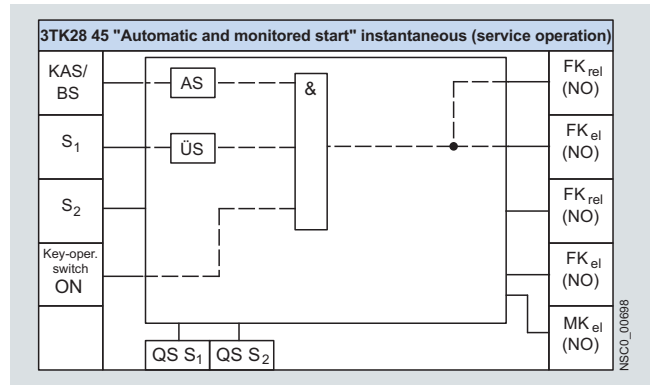
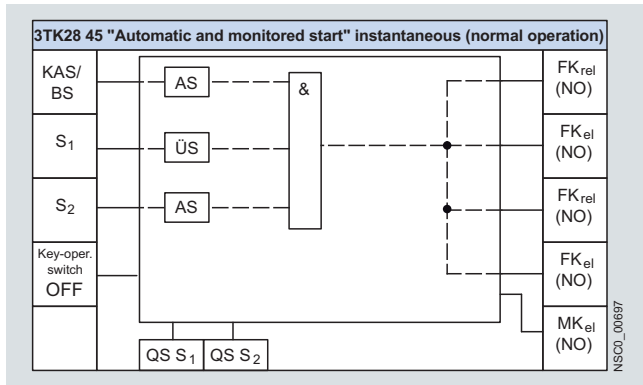

Legend

Sensor interface

KAS/BS: Cascading input or normal switching duty.
Normal switching duty: Connection of a PLC output for example. The enabling circuits and hence the connected loads can then be operated by the machine control.
 S_x : The safety function is on a higher level.
Sensor input

Key-operated switch: Bridging of the sensor connected to S_2 (normal/service operation)

Safety logic

AS: Automatic start. Device starts automatically once the enabling conditions are fulfilled. If a START button is integrated in the feedback circuit, a manual start is also possible (up to Category 3 according to EN 954-1).
ÜS: Monitored start. Device does not start until after the enabling conditions are fulfilled and a start signal is issued.

TV: Time delay, OFF-delay

Parameters

QS: With or without crossover monitoring

Actuator interface

FK_{el}: Enabling circuit, solid-state (non-floating)
FK_{rel}: Enabling circuit, relay contact (floating)
MK_{el}: Signaling circuit, solid-state (non-floating)
NO: NO contact
NO_{tv}: NO contact, time-delayed

3TK28 Safety Relays

With electronic enabling circuits

3TK28 45-.DB.. "Monitored start"

The 3TK28 45-.DB.. has two sensor inputs (S_1 , S_2 with monitored start), a cascading input (KAS/BS with autostart) and a changeover input (key-operated switch). On the output side are two relay enabling circuits, two solid-state enabling circuits and a solid-state signaling output.

Normal operation

In normal operation (key-operated switch "OFF"), all enabling circuits are activated. All inputs are "AND"-interconnected and act simultaneously on all enabling circuits, some time-delayed.

Service operation

In service operation (key-operated switch "ON"), only two of the four enabling circuits are activated. In this case the sensor input S_2 (e. g. protective door) has no function. The hazard area can be entered because the hazardous movement is switched off by means of the two inactive enabling circuits. The sensor input S_1 and the cascading input KAS/BS still act on the active enabling circuits.

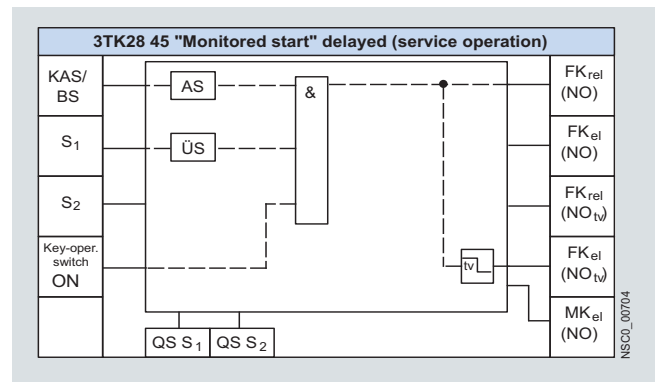
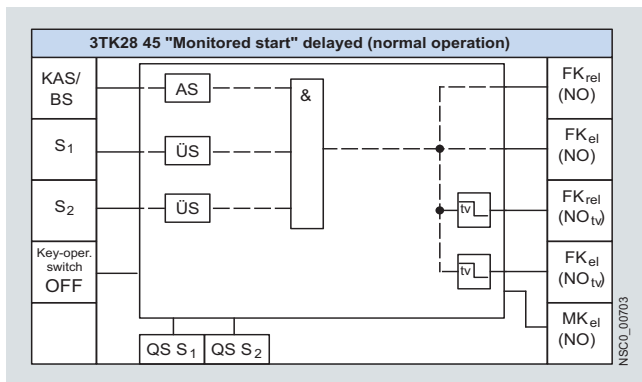
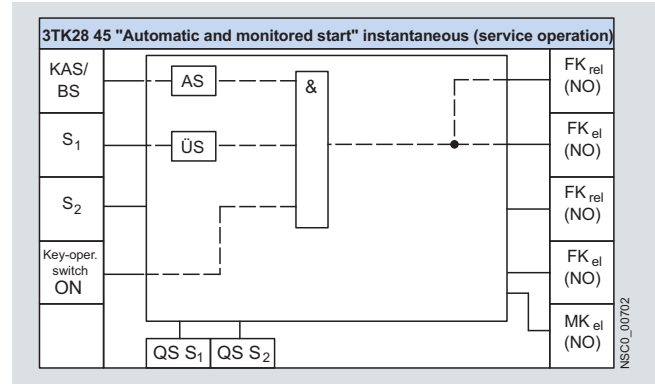
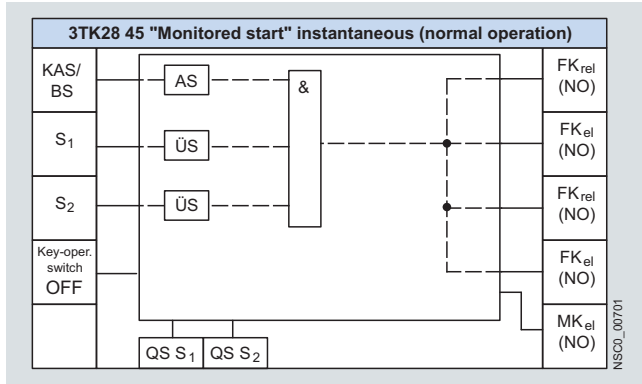

Legend

Sensor interface

KAS/BS: Cascading input or normal switching duty.
 Normal switching duty: Connection of a PLC output for example.
 The enabling circuits and hence the connected loads can then be operated by the machine control.
 The safety function is on a higher level.

S_x : Sensor input

Key-operated switch:

Bridging of the sensor connected to S_2 (normal/service operation)

Safety logic

AS: Automatic start. Device starts automatically once the enabling conditions are fulfilled. If a START button is integrated in the feedback circuit, a manual start is also possible (up to Category 3 according to EN 954-1).

ÜS: Monitored start. Device does not start until after the enabling conditions are fulfilled and a start signal is issued.



Time delay, OFF-delay

Parameters

QS: With or without crossover monitoring

Actuator interface

FK_{el}: Enabling circuit, solid-state (non-floating)
 FK_{rel}: Enabling circuit, relay contact (floating)
 MK_{el}: Signaling circuit, solid-state (non-floating)
 NO: NO contact
 NO_{tv}: NO contact, time-delayed

3TK28 45-.EB.. "OK button"

The 3TK28 45-.EB.. has two sensor inputs (S_1 OK button with autostart, S_2 protective door with selectable monitored start or automatic start), a cascading input (KAS/BS with autostart) and a changeover input (key-operated switch). On the output side are two relay enabling circuits, two solid-state enabling circuits and a solid-state signaling output.

Normal operation

In normal operation (key-operated switch "OFF"), all enabling circuits are activated. The cascading input KAS/BS and the protective door input S_2 are "AND"-interconnected and act simultaneously on all enabling circuits, some time-delayed. The input S_1 for the OK button has no function here. Opening the protective door or a missing signal at the cascading input KAS/BS will deactivate all enabling circuits.

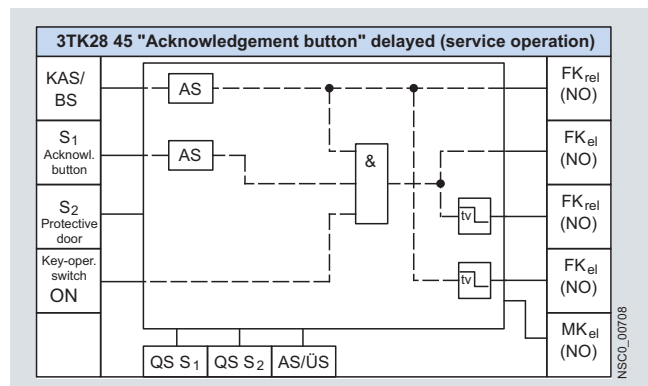
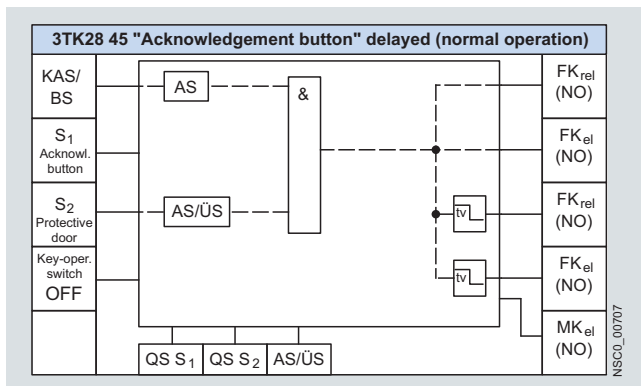
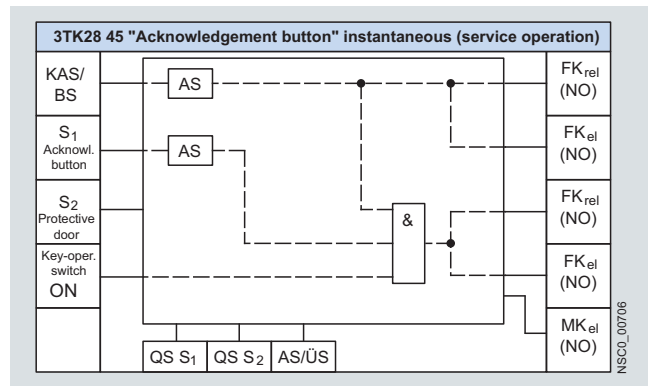
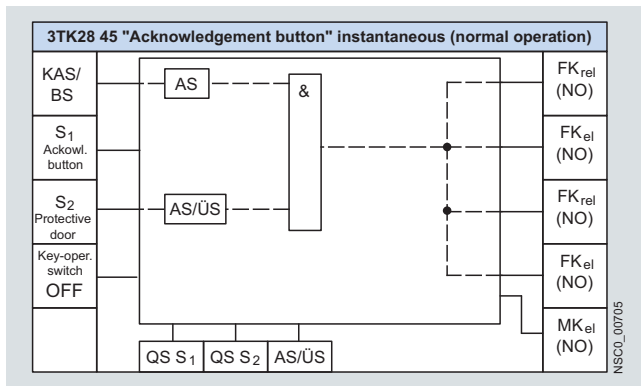
**Legend****Sensor interface**

KAS/BS: Cascading input or normal switching duty.
Normal switching duty: Connection of a PLC output for example. The enabling circuits and hence the connected loads can then be operated by the machine control.
The safety function is on a higher level.

S_x : Sensor input

Key-operated switch: Bridging of the sensor connected to S_2 (normal/service operation)

Safety logic

AS: Automatic start. Device starts automatically once the enabling conditions are fulfilled. If a START button is integrated in the feedback circuit, a manual start is also possible (up to Category 3 according to EN 954-1).

AS/ÜS: Automatic or monitored start depending on the parameterization



Time delay, OFF-delay

Parameters

QS: With or without crossover monitoring

AS/ÜS: Automatic or monitored start depending on the parameterization

Actuator interface

FK_{el} : Enabling circuit, solid-state (non-floating)

FK_{rel} : Enabling circuit, relay contact (floating)

MK_{el} : Signaling circuit, solid-state (non-floating)

NO: NO contact

3TK28 Safety Relays

With electronic enabling circuits

3TK28 45-.FB.. "Spring-type interlocking"

The 3TK28 45-.FB.. has two sensor inputs (S₁: EMERGENCY-STOP with monitored start, S₂: protective door with interlock and monitored start), a cascading input (KAS/BS with autostart) and a door-enabling input. On the output side are a relay solenoid control circuit, two solid-state enabling circuits, a relay solenoid control output and a solid-state signaling output.

Not enabled

If the protective door is not enabled, it cannot be opened. If the signal is no longer applied to the inputs S₁ or KAS/BS, the enabling circuit is deactivated.

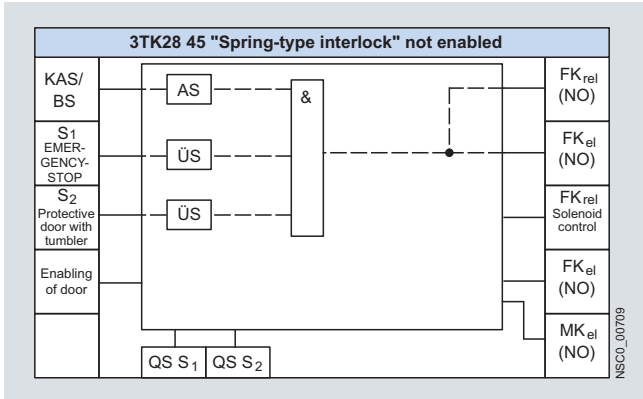

Enabled

With a signal at the door enabling input, the solenoid control output and the second solid-state enabling circuit are activated after the delay time has elapsed. The protective door is thus enabled.

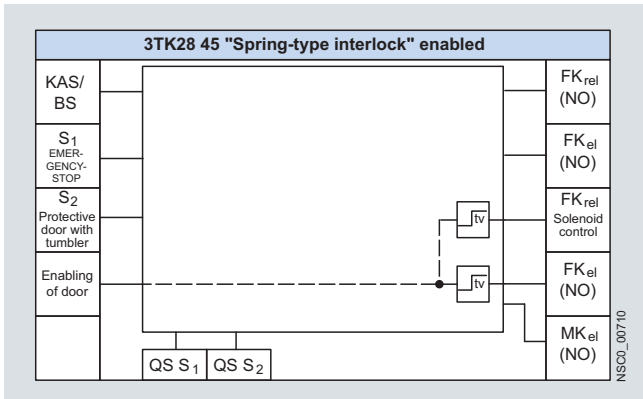

Legend

Sensor interface

KAS/BS: Cascading input or normal switching duty.
Normal switching duty: Connection of a PLC output for example. The enabling circuits and hence the connected loads can then be operated by the machine control.
The safety function is on a higher level.

S_x: Sensor input

Door enabling: Isolating the lock on the protective door

Safety logic

AS: Automatic start. Device starts automatically once the enabling conditions are fulfilled. If a START button is integrated in the feedback circuit, a manual start is also possible (up to Category 3 according to EN 954-1).

ÜS: Monitored start. Device does not start until after the enabling conditions are fulfilled and a start signal is issued.

Time delay, OFF-delay

Time delay, ON-delay

3TK28 45-.GB.. "Solenoid interlocking"

The 3TK28 45-.GB.. has two sensor inputs (S₁: EMERGENCY-STOP with monitored start, S₂: protective door with interlock and monitored start), a cascading input (KAS/BS with autostart) and a door-enabling input. On the output side are a relay solenoid control circuit, two solid-state enabling circuits, a relay solenoid control output and a solid-state signaling output.

Not enabled

If the protective door is not enabled, it cannot be opened. If the signal is no longer applied to the inputs S₁ or KAS/BS, the enabling circuit is deactivated.

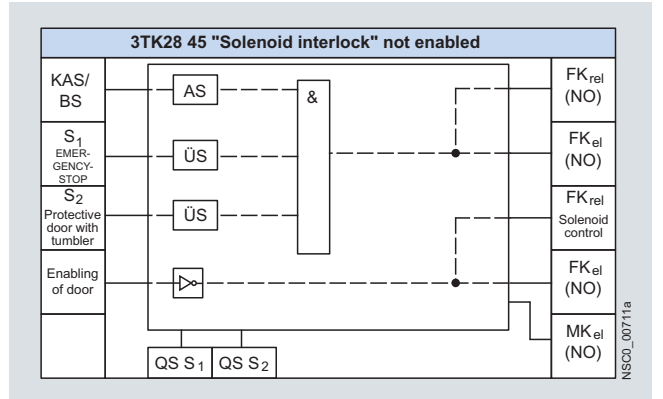

Enabled

With a signal at the door enabling input, the solenoid control output and the second solid-state enabling circuit are deactivated after the delay time has elapsed. The protective door is thus enabled.

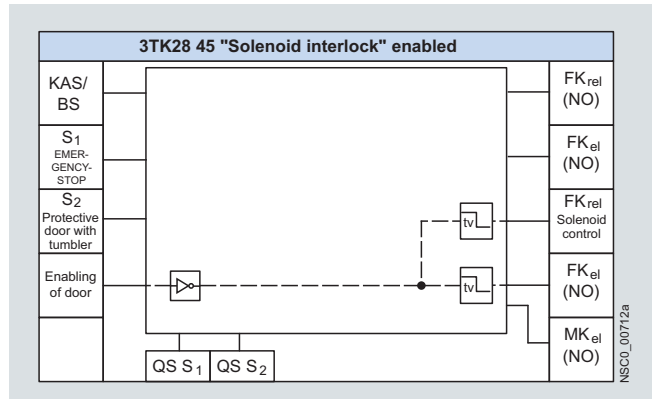

Parameters

QS: With or without crossover monitoring

Actuator interface



FK_{el}: Enabling circuit, solid-state (non-floating)

FK_{rel}: Enabling circuit, relay contact (floating)

MK_{el}: Signaling circuit, solid-state (non-floating)

NO: NO contact

Technical specifications

Type	3TK28 40	3TK28 41	3TK28 42	3TK28 45-..B40	3TK28 45-..B41 3TK28 45-..B42 3TK28 45-..B44	
General data						
Standards	EN 60204-1, EN ISO 12100, EN 954-1, IEC 61508	EN 60204-1, EN ISO 12100, EN 954-1, IEC 61508 EN 50156-1		EN 60204-1, EN ISO 12100, EN 954-1, IEC 61508		
Test certificates	TÜV, UL, CSA					
Safety-oriented output contacts						
• Instantaneous FK_{rel}	--			2	1	
• Time-delayed $FK_{rel}(tv)$	--			--	1	
Safety-oriented semiconductor outputs						
• Instantaneous FK_{el}	2		1	2	1	
• Time-delay $FK_{el}(tv)$	--		1	--	1	
Signaling contacts MK_{rel}	--					
Semiconductor signaling outputs MK_{rel}	--					
Sensor inputs S	1			2		
Cascading inputs KAS/BS	--		1			
Degree of protection acc. to EN 60529						
• Enclosure	IP40					
• Terminals	IP20					
Shock resistance sine wave	<i>g/ms</i>	8/10 and 15/5				
Permissible mounting positions	Any					
Touch protection acc. to EN 61140 or EN 60900	Finger-safe					
Height	mm	102: Screw terminals; 104: Spring-type terminals				
Width	mm	22.5		45		
Depth	mm	86		120		
Weight	kg	0.180		0.400		
Connection type	 Screw terminals					
• Terminal screw		M 3 (standard screwdriver, size 2 and Pozidriv 2)				
• Solid	mm ²	1 x (0.5 ... 4)/2 x (0.5 ... 2.5)				
• Finely stranded with end sleeve	mm ²	1 x (0.5 ... 2.5)/2 x (0.5 ... 1.5)				
• AWG cables, solid or stranded	AWG	2 x (24 ... 16)				
• Tightening torque	Nm	0.8 ... 1.2				
Connection type	 Spring-type terminals					
• Solid	mm ²	2 x (0.25 ... 1.5)				
• Finely stranded, with end sleeves acc. to DIN 46228	mm ²	2 x (0.25 ... 1.5)				
• Finely stranded	mm ²	2 x (0.25 ... 1.5)				
Electrical specifications						
Rated control supply voltage U_s	V	24 DC				
Operating range DC operation	V	0.9 ... 1.15 x U_s		0.85 ... 1.15 x U_s		
Rated insulation voltage U_i	V	50		50		
• For control circuit	V	50		50/300		
Rated impulse withstand voltage U_{imp}	V	500		500		
• For control circuit	V	500		500/4000		
Rated power at U_s	W	1.5	1.3	2.5		
Frequency ranges	Hz	--				
Rated operational current I_e (relay outputs) at	A	--				
• AC-15 at 115 V	A	--		3		
• AC-15 at 230 V	A	--		1		
• DC-13 at 24 V	A	--		--		
• DC-13 at 115 V	A	--		0.1		
• DC-13 at 230 V	A	--		--		
Rated operational current I_e (semiconductor outputs) at	A	0.5	1.5	0.5		
• DC-13 at 115 V	A	--	--	--		
Electrical endurance	Operating cycles	Unlimited				
Mechanical endurance	Operating cycles	--			10 ⁵	
Switching frequency z	1/h	2000				

3TK28 Safety Relays

With electronic enabling circuits

Technical specifications

Type		3TK28 40	3TK28 41	3TK28 42	3TK28 45-..B40	3TK28 45-..B41 3TK28 45-..B42 3TK28 45-..B44
Electrical specifications (continued)						
Conventional thermal current I_{th}		--				
Conventional thermal current I_{th}						
• 1 contact	A	--				
• 2 contacts	A	--				
• 3 contacts	A	--				
• 4 contacts	A	--				
Fusing for output contacts						
Fuse links LV HRC Type 3NA, DIAZED Type 5SB, NEOZED Type 5SE, gL/gG operational class						
• gL/gG		Not required				
• Quick		Not required				
Maximum line resistance	Ω	250	1000			
Cable length from terminal to terminal	m	2000			1000	
With Cu 1.5 mm ² and 150 nF/km						
Times						
Bridging of voltage dips, supply voltage (only internal, no outputs)	ms	25				
Make-time t_E						
• For automatic start typ.	ms	80	60		60	
• For automatic start max.	ms	100	100		100	
• For automatic start after mains failure typ.	ms	350	6000		--	
• For automatic start after mains failure max.	ms	500	7000		--	
• For monitored start typ.	ms	60	60		60	
• For monitored start max.	ms	100	100		100	
Release time t_R						
• For sensor typ.	ms	20	45	--	45	--
• For sensor max.	ms	30	60	0.05 ... 300 Adjustable	--	0.05 ... 300 Adjustable
• For mains failure typ.	ms	0	0	0	25	25
• For mains failure max.	ms	0	0	0	30	30
Recovery time t_W						
• After sensor	ms	120	400		400	
• After mains failure	s	0.5	Max. 7		Max. 8	
Minimum command duration t_B						
• Sensor input	ms	5	45			
• ON button input	ms	60	200 ... 5000			
• Cascading input	ms	5	45			
Simultaneity t_G	ms	∞				
Temperatures						
Permissible ambient temperature						
• During operation	°C	-25 ... +60				
• During storage	°C	-40 ... +80				
Safety specifications						
Safety integrity level SIL CL		2	3			
acc. to IEC 61508						
Performance level PL		--				e
acc. to ISO 13849-1						
Safety category CAT		3	4			
acc. to EN 954-1						
Type		--				
acc. to EN 574						
Probability of a dangerous failure						
• Per hour (PFH _D)	1/h	1.05 × 10 ⁻⁸	5.36 × 10 ⁻¹¹		6.86 × 10 ⁻⁹	
• On demand (PFD)		--	--		--	
Proof-test interval T1	a	10			20	
Environmental data						
EMC		EN 60947-5-1, EN 61000-6-2, EN 61000-6-4		IEC 60947-5-1, IEC 60000-4-3, IEC 60000-4-5, IEC 60000-4-6		
Vibrations						
acc. to EN 60068-2-6						
• Frequency	Hz	5 ... 500				
• Amplitude	mm	0.075				
Climatic withstand capability		EN 60068-2-78				
Clearances in air and creepage distances		EN 60947-1				

3TK28 Safety Relays

With electronic enabling circuits

Dimensional drawings

3TK28 40 to 3TK28 42 with screw terminals

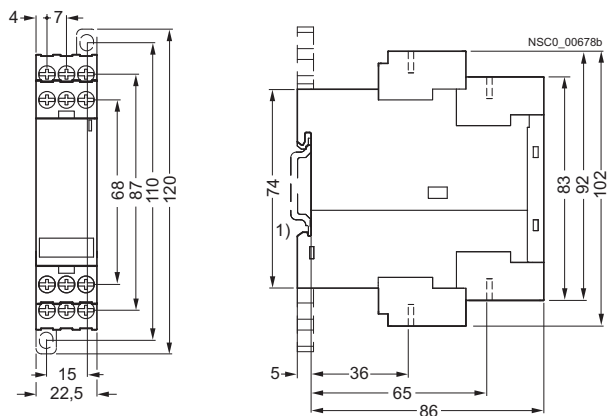

3TK28 40 to 3TK28 42 with spring-type terminals

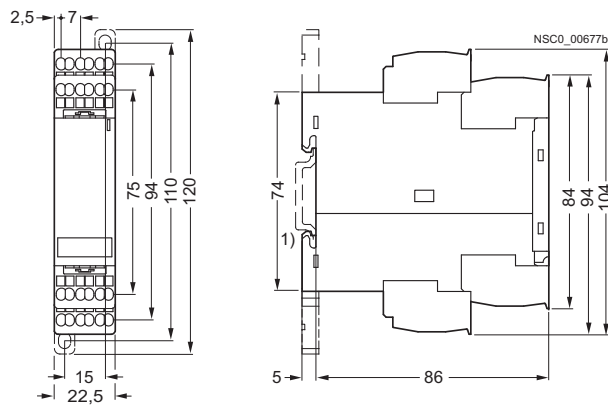

3TK28 45 with screw terminals

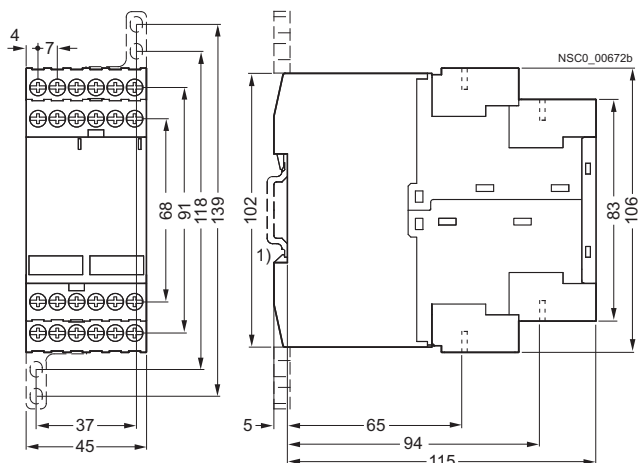

3TK28 45 with spring-type terminals

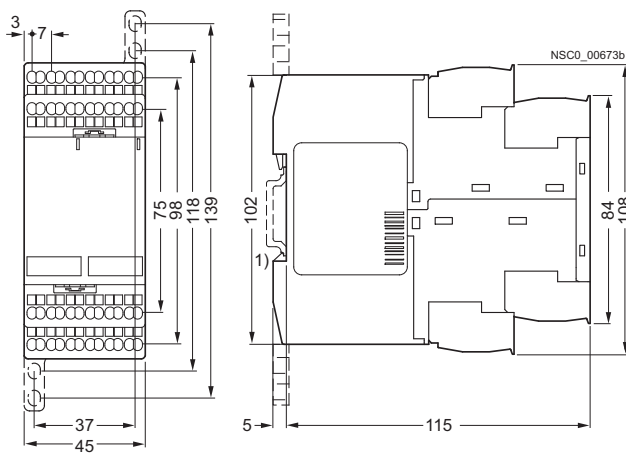

1) For standard mounting rail TH 35 according to EN 60715.

Schematics

3TK28 40

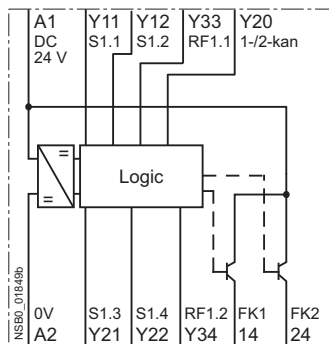

3TK28 41

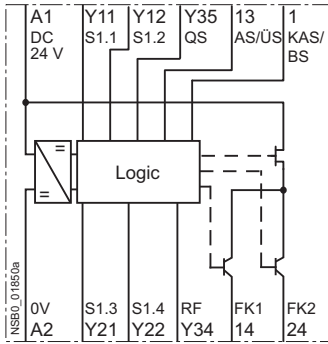

3TK28 42

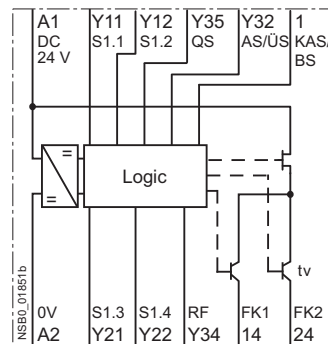

Legend

FK_{x,x'}: Enabling circuits
 S_{x,x'}: Sensor terminals (test connectors)
 RF_{x,x'}: Feedback circuit terminals
 1-2-kan: Parameter terminal switchover, one/two-channel

QS: Parameter terminal with crossover monitoring (ON/OFF)
 AS/ÜS: Parameter terminal switchover, automatic/monitored start
 KAS/BS: Terminal, cascading input/normal switching
 tv: Time-delayed outputs

3TK28 Safety Relays

With electronic enabling circuits

3TK28 45-.HB40, -.DB40

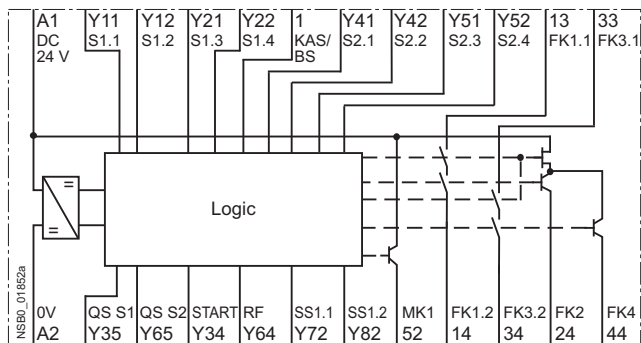

3TK28 45-.EB41, -.EB42, -.EB44

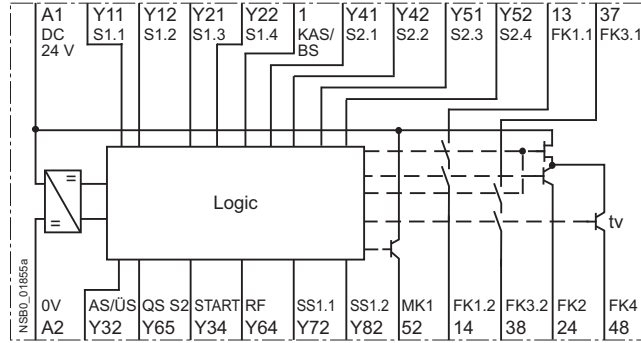

3TK28 45-.HB41, -.HB42, -.HB44, -.DB41, -.DB42, -.DB44

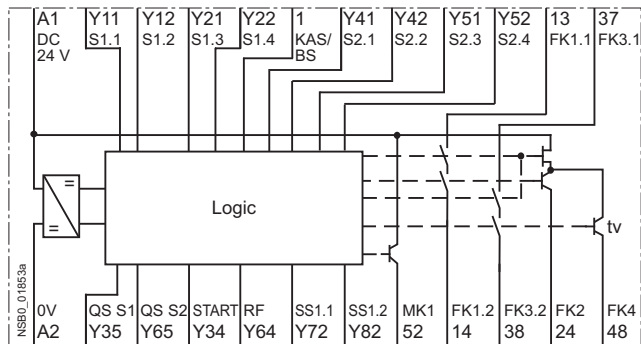

3TK28 45-.FB41, -.FB42, -.FB44, -.GB41, -.GB42, -.GB44

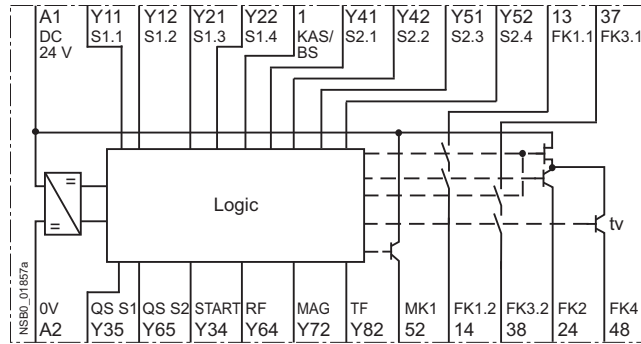

3TK28 45-.EB40

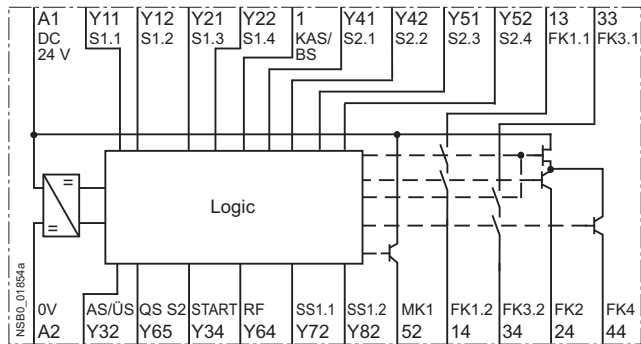

Legend

- FK_{x,x}: Enabling circuits
- S_{x,x}: Sensor terminals (test connectors)
- RF_{x,x}: Feedback circuit terminals
- MK_{x,x}: Indicating circuit terminals
- START: Start signal terminal
- QS: Parameter terminal with crossover monitoring (ON/OFF)
- AS/ÜS: Parameter terminal switchover, automatic/monitored start
- KAS/BS: Terminal, cascading input/normal switching
- SS_{x,x}: Key-operated switch terminals
- MAG: Magnetic monitoring
- TF: Door enabling
- tv: Time-delayed outputs

7

Design

The 3TK28 21 to 3TK28 28, 3TK28 30 and 3TK28 34 safety relays operate with internal contactor relays with positively-driven contacts. The contacts of the controls comply with the requirement for positively-driven operation laid down in ZH 1/457, Edition 2, 1978. NO and NC contacts are not allowed to be closed at the same time.

In a redundant circuit, operation of the internal controls is monitored. If a safety relay fails, it will always switch to the de-energized and consequently safe state. The fault is detected and the safety relay can no longer be switched on.

This product series is characterized by its space-saving width (22.5 mm or 45 mm). The usual BIA, BG and SUVA approvals and test certificates have been awarded.

Enabling contacts (FK)

Safety related operation must be performed by safe output contacts, known as enabling contacts. Enabling contacts are always NO contacts and switch without delay.

Signaling contacts (MK)

NC contacts are used as signaling contacts but they are not permitted to perform functions with relevance for safety. An enabling contact can also be used as a signaling contact. A signaling contact cannot, however, be used as an enabling contact.

Delayed enabling contacts

Machine drives that overrun for a long time must be externally braked in the event of danger. For this purpose, the energy in-feed for electrical braking can be maintained (Stop Category 1 according to EN 60204-1).

The basic units have off-delay enabling contacts in addition to instantaneous enabling contacts. Delay times of between 0.5 ... 30 s are available with the different versions. A 3RP19 02 sealable cover can be fitted to protect against unauthorized adjustment of the set delay time.

Expansion units

If the enabling contacts of the basic unit are inadequate, expansion units can be used. An expansion unit has 4 enabling contacts.

Expansion units are not allowed to be operated separately in safety-related switching circuits; they must be combined with a basic unit. One enabling contact of the basic unit is required for connecting an expansion unit. The category of a control system with expansion unit corresponds to that of the basic unit.

Mounting

The equipment is designed for snap-on mounting on a TH 35 standard mounting rail according to EN 60715. Screw fixing is also possible for the devices by means of 2 additional 3RP19 03 push-in lugs.

Function

Basic units

3TK28 21 to 3TK28 24

The devices 3TK28 21 to 3TK28 24 each have one sensor input and a varying number of relay enabling circuits and signaling outputs. If the signal is no longer applied to the sensor input, the enabling circuits are disconnected immediately or according to the set delay timed.

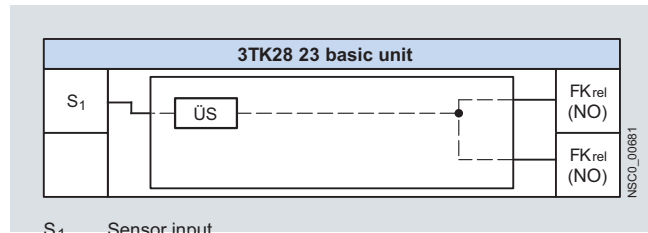
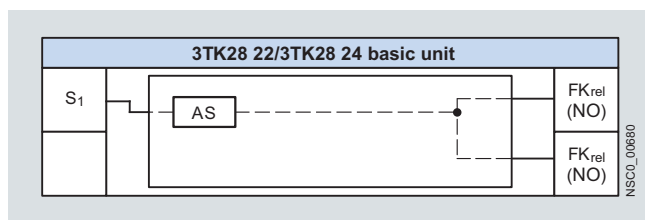
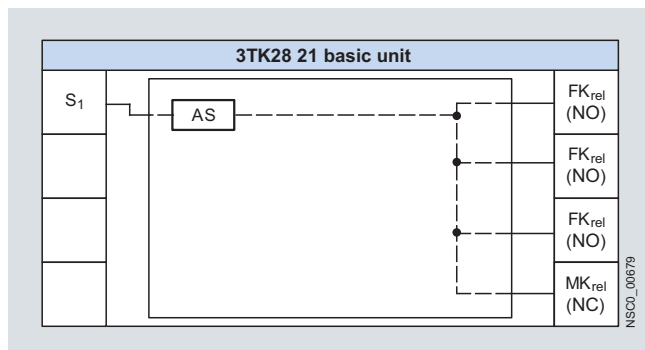

Legend

Sensor interface

S_x: Sensor input

Safety logic

AS: Automatic start. Device starts automatically once the enabling conditions are fulfilled. If a START button is integrated in the feedback circuit, a manual start is also possible (up to Category 3 according to EN 954-1).

ÜS: Monitored start. Device does not start until after the enabling conditions are fulfilled and a start signal is issued.

Actuator interface

FK_{rel}: Enabling circuit, relay contact (floating)

MK_{rel}: Signaling circuit, relay contact (non-floating)

NC: NC contact

NO: NO contact

3TK28 Safety Relays

With relay enabling circuits

Basic units

3TK28 25, 3TK28 27 and 3TK28 28

The devices 3TK28 25, 3TK28 27 and 3TK28 28 each have one sensor input and a varying number of contactor relay enabling circuits and signaling outputs. If the signal is no longer applied to the sensor input, the enabling circuits are disconnected immediately or according to the set delay timed.

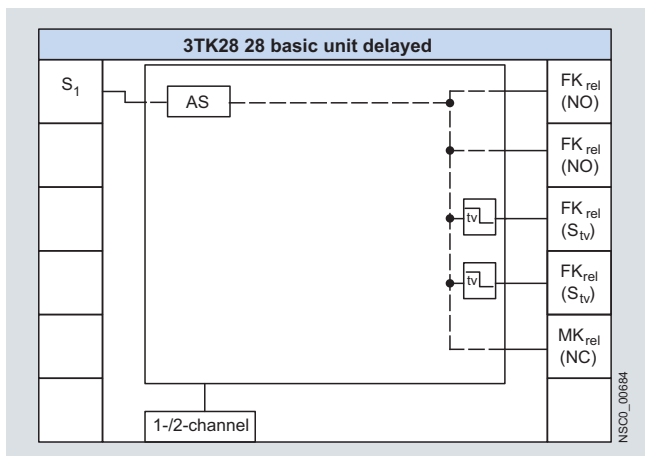
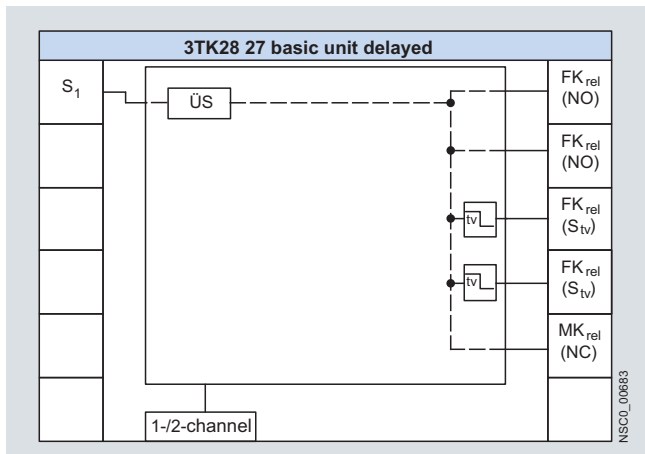
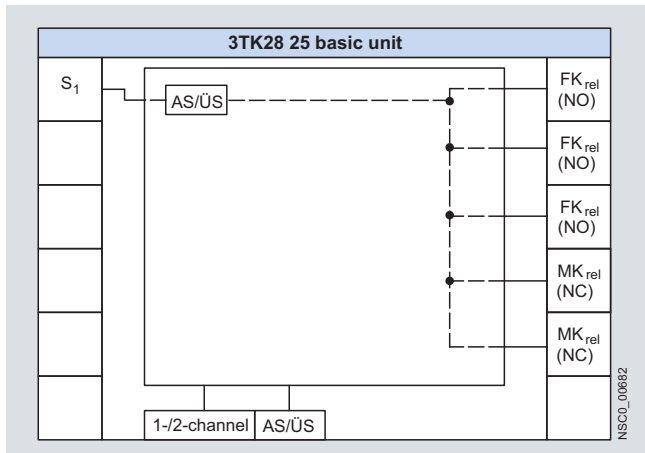

Basic units

3TK28 26

The 3TK28 26 safety relay combines several functions in one unit. The sensor input S₁ and the cascading input KAS are suitable for connecting sensors with contacts, non-contact sensors (electronic sensors), safety mats and NC/NO magnetically operated switches.

DIP switches mounted on the front can be used to adapt the functions of the device to the functions required.

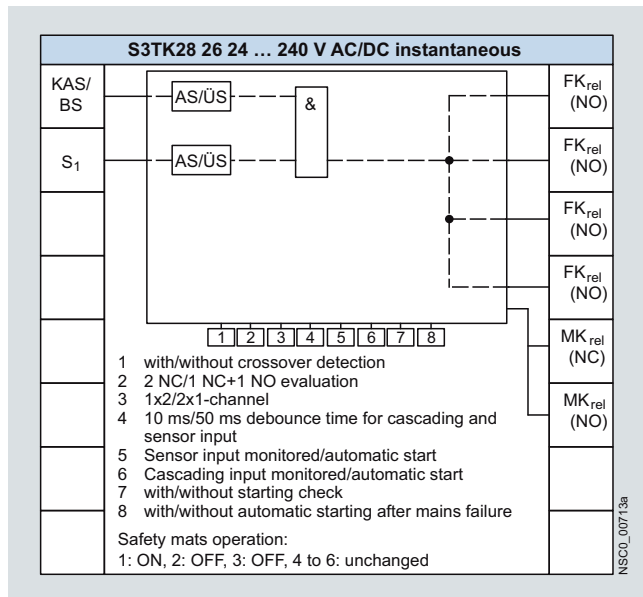
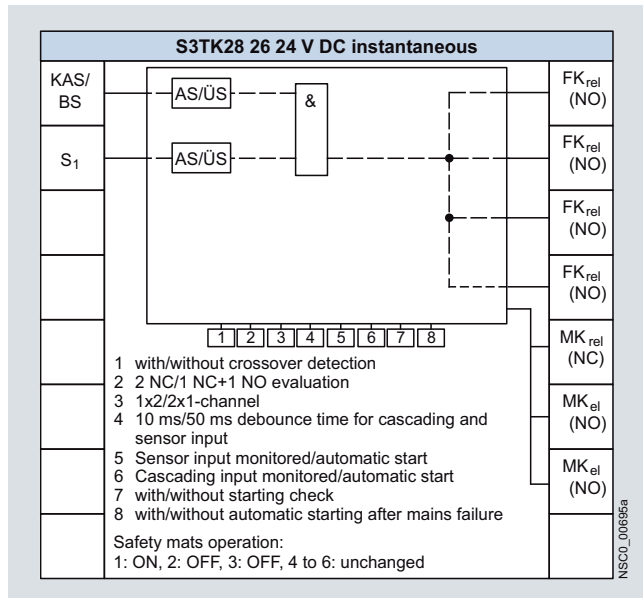

For legend see page 7/129.

3TK28 Safety Relays

With relay enabling circuits

Basic units

3TK28 26 (continued)

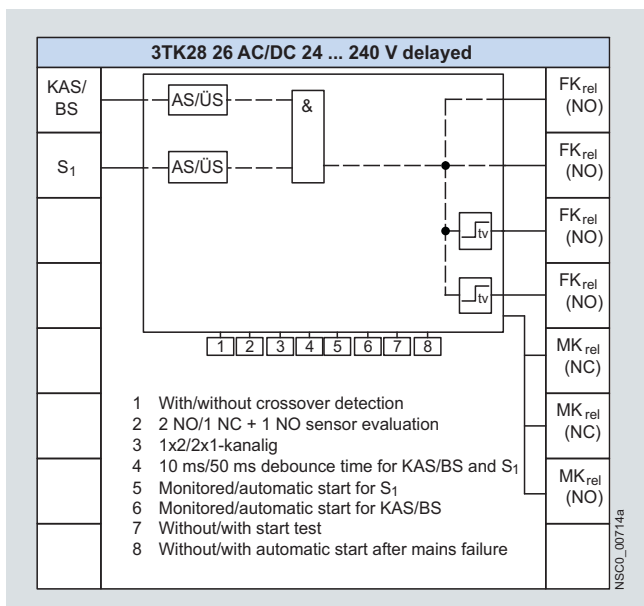
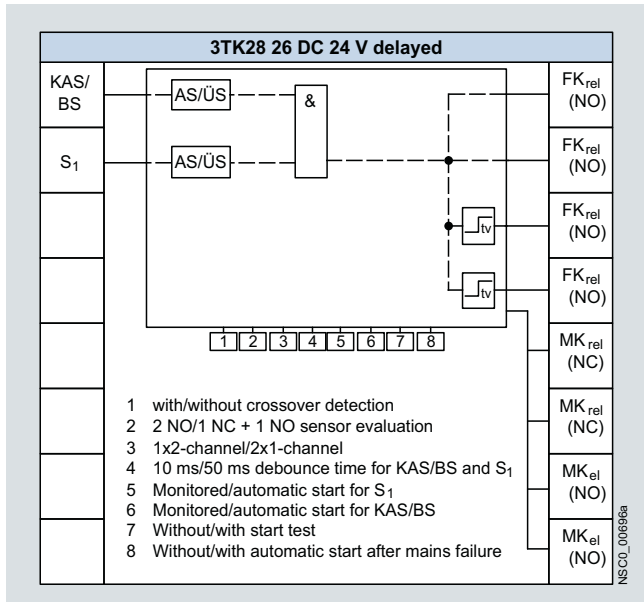

Expansion units

3TK28 30

The 3TK28 30 is activated through the power supply input A1. On the output side are four contactor relay enabling circuits. If the signal is no longer applied to the input, the enabling circuits are isolated immediately.

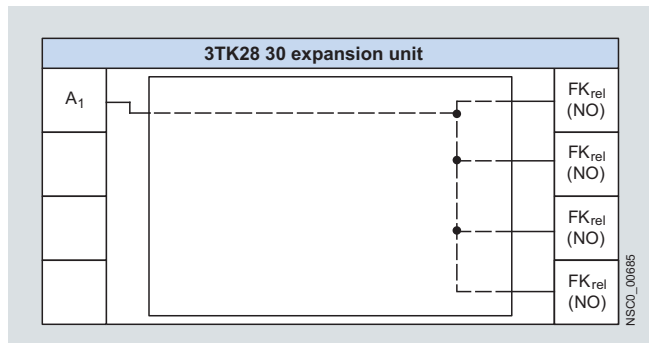

Legend

Sensor interface

- S_x: Sensor input
- A1: Power supply input as sensor input or cascading input
- KAS/BS: Cascading input or normal switching duty.
Normal switching duty: Connection of a PLC output for example. The enabling circuits and hence the connected loads can then be operated by the machine control. The safety function is on a higher level.

Safety logic

- AS: Automatic start. Device starts automatically once the enabling conditions are fulfilled. If a START button is integrated in the feedback circuit, a manual start is also possible (up to Category 3 according to EN 954-1).
- AS/ÜS: Automatic or monitored start depending on the parameterization
- ÜS: Monitored start. Device does not start until after the enabling conditions are fulfilled and a start signal is issued.



Time delay, OFF-delay



Time delay, ON-delay

Parameters

- 1 to 8: See drawing
- 1-/2-channel: One-channel / two-channel sensor connection
- AS/ÜS: Automatic or monitored start depending on the parameterization



Actuator interface

- FK_{rel}: Enabling circuit, relay contact (floating)
- MK_{rel}: Signaling circuit, solid-state (non-floating)
- MK_{rel}: Signaling circuit, relay contact (non-floating)
- NC: NC contact
- NO: NO contact
- S_v: NO contact, time-delayed

3TK28 Safety Relays

With relay enabling circuits



Technical specifications

Type		3TK28 21	3TK28 22	3TK28 23	3TK28 24- ..B0.0	3TK28 24-..A.20	3TK28 25
General data							
Standards		EN 60204-1, EN ISO 12100, EN 954-1, IEC 61508					
Test certificates		BG, SUVA, UL, CSA					
Safety-oriented output contacts							
• Instantaneous FK_{rel}		3	2				3
• Time-delayed $FK_{rel}(tv)$		--	--				--
Safety-oriented semiconductor outputs							
• Instantaneous FK_{el}		--					
• Time-delay $FK_{el}(tv)$		--					
Signaling contacts MK_{rel}		1	--				2
Semiconductor signaling outputs MK_{rel}		--					
Sensor inputs S		1					
Cascading inputs KAS/BS		--					
Degree of protection acc. to EN 60529							
• Enclosure		IP40					
• Terminals		IP20					
Shock resistance sine wave	g/ms	8/10					
Permissible mounting positions		Any					
Touch protection acc. to EN 61140 or EN 60900		Finger-safe					
Height	mm	102: screw terminals; 104: spring-type terminals					
Width	mm	22.5					
Depth	mm	115					
Weight	kg	0.240					0.460
Connection type		 Screw terminals					
• Terminal screw		M 3 (standard screwdriver, size 2 and Pozidriv 2)					
• Solid	mm ²	1 x (0.5 ... 4)/2 x (0.5 ... 2.5)					
• Finely stranded with end sleeve	mm ²	1 x (0.5 ... 2.5)/2 x (0.5 ... 1.5)					
• AWG cables, solid or stranded	AWG	2 x (24 ... 16)					
• Tightening torque	Nm	0.8 ... 1.2					
Connection type		 Spring-type terminals					
• Solid	mm ²	2 x (0.25 ... 1.5)					
• Finely stranded, with end sleeves acc. to DIN 46228	mm ²	2 x (0.25 ... 1.0)					
• Finely stranded	mm ²	2 x (0.25 ... 1.5)					
• Stripped length	mm	10					
Electrical specifications							
Rated control supply voltage U_s	V	24 AC/DC				115/230 AC	24/115/230 AC, 24 DC
Operating range							
• AC operation	V	0.85 ... 1.1 x U_s				0.85 ... 1.1 x U_s	0.85 ... 1.1 x U_s
• DC operation	V	0.85 ... 1.2 x U_s				--	0.85 ... 1.1 x U_s
Measurement voltage	V	--					
Response value U_{resp}	mV	--					
Rated insulation voltage U_i							
• For control circuit	V	--					
• For outputs	V	300					
Rated impulse withstand voltage U_{imp}							
• For control circuit	V	--					
• For outputs	V	4000 ...					
Rated power	W	1.5					3
Frequency ranges	Hz	50/60					
Rated operational current I_e (relay outputs) at							
• AC-15 at 115 V	A	5					6
• AC-15 at 230 V	A	5					6
• DC-13 at 24 V	A	5					6
• DC-13 at 115 V	A	0.2					0.2
• DC-13 at 230 V	A	0.1					0.1
Rated operational current I_e (semiconductor outputs) at							
• DC-13 at 24 V	A	--					
• DC-13 at 230 V	A	--					

Type		3TK28 21	3TK28 22	3TK28 23	3TK28 24- ..B0.0	3TK28 24-.A.20	3TK28 25
Electrical specifications (continued)							
Electrical endurance	Operating cycles	10 ⁵					
Mechanical endurance	Operating cycles	10 ⁷					
Switching frequency z	1/h	1000					
Conventional thermal current I_{th}	A	5					6
Conventional thermal current I_{th}							
• 1 contact	A	--					
• 2 contacts	A	--					
• 3 contacts	A	--					
• 4 contacts	A	--					
Fusing for output contacts							
Fuse links LV HRC Type 3NA, DIAZED Type 5SB, NEOZED Type 5SE, gL/gG operational class							
• gL/gG	A	6		6		6	
• Quick	A	10; Signaling circuit: 6		10; Signaling circuit: 6		10	
Maximum line resistance	Ω	30					
Cable length from terminal to terminal With Cu 1.5 mm ² and 150 nF/km	m	1000					
Times							
Bridging of voltage dips, supply voltage (only internal, no outputs)	ms	60	30	80	60	100	
Make-time t_E							
• For automatic start typ.	ms	--	--	--	--	--	--
• For automatic start max.	ms	AC: 300, DC: 200	125	--	AC: 300, DC: 200	300	150
• For automatic start after mains failure typ.	ms	--	--	--	--	--	--
• For automatic start after mains failure max.	ms	--	--	--	--	--	--
• For monitored start typ.	ms	--	--	--	--	--	--
• For monitored start max.	ms	--	--	30	--	--	25
Release time t_R							
• For sensor typ.	ms	--	--	--	--	--	--
• For sensor max.	ms	200	20	20	200	--	25
• For mains failure typ.	ms	--	--	--	--	--	--
• For mains failure max.	ms	200	100	150	200	--	350
Recovery time t_W							
• After sensor	ms	Min. 200		Min. 400	Min. 200	Min. 200	
• After mains failure	s	Min. 200		Min. 600	Min. 200	Min. 500	
Minimum command duration t_B							
• Sensor input	ms	Min. 200	Min. 25	Min. 25	Min. 200	Min. 300	Min. 25
• ON button	s	Min. 150	Min. 40	Min. 25	Min. 150	Min. 300	Min. 25
• Cascading input	s	--	--	--	--	--	--
Simultaneity t_G	ms	∞					
Temperatures							
Permissible ambient temperature							
• During operation	°C	-25 ... +60					
• During storage	°C	-40 ... +80					
Safety specifications							
Safety integrity level SIL CL acc. to IEC 61508		2	--	--	2	3	
Performance level PL acc. to ISO 13849-1		--					
Safety category CAT acc. to EN 954-1		3	4	--	3	4	
Type acc. to EN 574		--					
Probability of a dangerous failure							
• Per hour (PFH _D)	1/h	2 x 10 ⁻⁷	--	--	2 x 10 ⁻⁷	3 x 10 ⁻⁸	
• On demand (PFD)		--	--	--	--	--	
Proof-test interval T1	a	20					
Environmental data							
EMC		EN 60947-5-1					
Vibrations acc. to EN 60068-2-6							
• Frequency	Hz	5 ... 500					
• Amplitude	mm	0.075					
Climatic withstand capability		EN 60068-2-1, EN 60068-2-2, EN 60068-2-14, EN 60068-2-30					
Clearances in air and creepage distances		EN 60947-1					

3TK28 Safety Relays

With relay enabling circuits



Type		3TK28 26-.BB40	3TK28 26-.CW30	3TK28 26-.BB41 3TK28 26-.BB42 3TK28 26-.BB44	3TK28 26-.CW31 3TK28 26-.CW32 3TK28 26-.CW44	3TK28 27
General data						
Standards		EN 60204-1, EN ISO 12100, EN 954-1, IEC 61508				
Test certificates		TÜV, UL, CSA				BG, SUVA, UL, CSA
Safety-oriented output contacts						
• Instantaneous FK_{rel}		4		2		
• Time-delayed $FK_{rel(tv)}$		--		2		
Safety-oriented semiconductor outputs						
• Instantaneous FK_{el}		--				
• Time-delay $FK_{el(tv)}$		--				
Signaling contacts MK_{rel}		1	2		3	1
Semiconductor signaling outputs MK_{rel}		2	--	2	--	
Sensor inputs S		1				
Cascading inputs KAS/BS		1				--
Degree of protection acc. to EN 60529						
• Enclosure		IP40				
• Terminals		IP20				
Shock resistance sine wave	g/ms	8/10				
Permissible mounting positions		Any				
Touch protection acc. to EN 61140 or EN 60900		Finger-safe				
Height	mm	106: screw terminals; 108: spring-type terminals				
Width	mm	45				
Depth	mm	116				115
Weight	kg	0.350				0.580
Connection type		 Screw terminals				
• Terminal screw		M 3 (standard screwdriver, size 2 and Pozidriv 2)				
• Solid	mm ²	1 x (0.5 ... 4)/2 x (0.5 ... 2.5)				
• Finely stranded with end sleeve	mm ²	1 x (0.5 ... 2.5)/2 x (0.5 ... 1.5)				
• AWG cables, solid or stranded	AWG	2 x (24 ... 16)				
• Tightening torque	Nm	0.8 ... 1.2				
Connection type		 Spring-type terminals				
• Solid	mm ²	2 x (0.25 ... 1.5)				
• Finely stranded, with end sleeves acc. to DIN 46228	mm ²	2 x (0.25 ... 1.0)				
• Finely stranded	mm ²	2 x (0.25 ... 1.5)				
• Stripped length	mm	10				
Electrical specifications						
Rated control supply voltage U_s	V	24 DC	24 ... 240 AC/DC	24 DC	24 ... 240 AC/DC	24 DC, 24/115/230 AC
Operating range						
• AC operation	V	--	0.9 ... 1.1 x U_s	--	0.9 ... 1.1 x U_s	0.85 ... 1.1 x U_s
• DC operation	V	0.85 ... 1.2 x U_s	0.9 ... 1.1 x U_s	0.85 ... 1.2 x U_s	0.9 ... 1.1 x U_s	0.85 ... 1.1 x U_s
Measurement voltage	V	--				
Response value U_{resp}	mV	--				
Rated insulation voltage U_i						
• For control circuit	V	--				
• For outputs	V	300				
Rated impulse withstand voltage U_{imp}						
• For control circuit	V	--				
• For outputs	V	4000				
Rated power	W	3				
Frequency ranges	Hz	50/60				
Rated operational current I_e (relay outputs) at						
• AC-15 at 115 V	A	13/14, 23/24, 33/34, 43/44: 4 51/52: 3	13/14, 23/24, 33/34, 43/44: 4 51/52: 3	13/14, 23/24, 33/34, 43/44: 4 51/52: 3	13/14, 23/24, 33/34, 43/44: 4 51/52: 3	--
• AC-15 at 230 V	A	13/14, 23/24, 33/34, 43/44: 4 51/52: 3	13/14, 23/24, 33/34, 43/44: 4 51/52: 3	13/14, 23/24, 47/48, 57/58: 4 31/32, 61/62: 3	13/14, 23/24, 33/34, 43/44: 4 51/52: 3	13/14, 23/24, 47/48, 57/58: 4 31/32, 61/62: 3
• DC-13 at 24 V	A	13/14, 23/24, 33/34, 43/44: 4 51/52: 2	13/14, 23/24, 33/34, 43/44: 4 51/52: 2, 63/64: 1	13/14, 23/24, 47/48, 57/58: 4 31/32, 61/62: 2	13/14, 23/24, 47/48, 57/58: 4 31/32, 61/62: 2	13/14, 23/24, 47/48, 57/58: 4 73/74: 1
• DC-13 at 115 V	A	0.2	0.2	0.2	0.2	0.2
• DC-13 at 230 V	A	0.1	0.1	0.1	0.1	0.1
Rated operational current I_e (semiconductor outputs) at						
• DC-13 at 24 V	A	64, 75: 0.5	--	74, 84: 0.5	--	--
• DC-13 at 230 V	A	--	--	--	--	--

Type		3TK28 26-.BB40	3TK28 26-.CW30	3TK28 26-.BB41 3TK28 26-.BB42 3TK28 26-.BB44	3TK28 26-.CW31 3TK28 26-.CW32 3TK28 26-.CW44	3TK28 27
Electrical specifications (continued)						
Electrical endurance	Oper. cycles	--				10 ⁵
Mechanical endurance	Oper. cycles	10 ⁷				
Switching frequency z	1/h	2000				1000
Conventional thermal current I_{th}	A	Summation current max. 12				5
Conventional thermal current I_{th}						
• 1 contact	A	4				
• 2 contacts	A	4				
• 3 contacts	A	4				
• 4 contacts	A	3				
Fusing for output contacts						
Fuse links LV HRC Type 3NA, DIAZED Type 5SB, NEOZED Type 5SE, gL/gG operational class	A	4				6 (control voltage: 2) 10
• gL/gG	A	4				
• Quick	A	6				
Maximum line resistance	Ω	1000				30
Cable length from terminal to terminal	m	2000				1000
With Cu 1.5 mm ² and 150 nF/km						
Times						
Bridging of voltage dips, supply voltage	ms	Min. 10				30
(only internal, no outputs)						
Make-time t_E						
• For automatic start typ.	ms	50 + debounce time				--
• For automatic start max.	ms	50 + debounce time				--
• For automatic start after mains failure typ.	ms	Approx. 8000 starting time				Approx. 8000 starting time
• For automatic start after mains failure max.	ms	Approx. 8000 starting time				Approx. 8000 starting time
• For monitored start typ.	ms	50 + debounce time				--
• For monitored start max.	ms	50 + debounce time				80
Release time t_R						
• For sensor typ.	ms	50 + deb. time	50 + deb. time	--	--	--
• For sensor max.	ms	--	--	50+ deb. time	50+ deb. time	≤ 30 adjustable
• For mains failure typ.	ms	75	--	75	--	--
• For mains failure max.	ms	125	300	125	320	100
Recovery time t_{WR}						
• After sensor	ms	Min. 250		Min. 250	Min. 250	After time has elapsed
• After mains failure	s	Min. 200		Min. 600	Min. 200	Min. 200
Minimum command duration t_B						
• Sensor input	ms	30				Min. 25
• ON button	s	0.2 ... 5				Min. 25
• Cascading input	s	--				--
Simultaneity t_G	ms	∞				
Temperatures						
Permissible ambient temperature						
• During operation	°C	-25 ... +60				
• During storage	°C	-40 ... +80				
Safety specifications						
Safety integrity level SIL CL		3				Stop cat. 0: 3 Stop cat. 1: 2
acc. to IEC 61508						
Performance level PL		e				--
acc. to ISO 13849-1						
Safety category CAT		4				Stop cat. 0: 4 Stop cat. 1: 3
acc. to EN 954-1						
Type		--				
acc. to EN 574						
Probability of a dangerous failure						
• Per hour (PFH _D)	1/h	7.8 x 10 ⁻⁹	7.8 x 10 ⁻⁹	7.8 x 10 ⁻⁹	7.8 x 10 ⁻⁹	Stop cat. 0: 3 x 10 ⁻⁸ Stop cat. 1: 2 x 10 ⁻⁷
• On demand (PFD)	--	--	--	--	--	--
Proof-test interval T1	a	20				
Environmental data						
EMC		EN 60947-5-1				
Vibrations		acc. to EN 60068-2-6				
• Frequency	Hz	5 .. 500				
• Amplitude	mm	0.075				
Climatic withstand capability		EN 60068-2-1, EN 60068-2-2, EN 60068-2-14, EN 60068-2-30				
Clearances in air and creepage distances		EN 60947-1				

1) Time-delayed enabling circuit: ≤ 300 ms adjustable.

3TK28 Safety Relays

With relay enabling circuits

Type		3TK28 28	3TK28 30	3TK28 34	3TK28 35
General data					
Standards		EN 60204-1, EN ISO 12100, EN 954-1, IEC 61508		EN 60204-1, EN ISO 12100, EN 954-1, IEC 61508, EN 574	
Test certificates		BG, SUVA, UL, CSA, TÜV			
Safety-oriented output contacts					
• Instantaneous FK_{rel}		2	4	2	4
• Time-delayed $FK_{rel}(tv)$		2	--	--	--
Safety-oriented semiconductor outputs					
• Instantaneous FK_{el}		--			
• Time-delay $FK_{el}(tv)$		--			
Signaling contacts MK_{rel}		1		2	--
Semiconductor signaling outputs MK_{rel}		--			
Sensor inputs S		1	--	1	
Cascading inputs KAS/BS		--			
Degree of protection acc. to EN 60529					
• Enclosure		IP40	IP20		
• Terminals		IP20	IP20		
Shock resistance sine wave	g/ms	8/10			
Permissible mounting positions		Any			
Touch protection acc. to EN 61140 or EN 60900		Finger-safe			
Height	mm	106 (3TK28 30: 102): screw terminals; 108 (3TK28 30: 104): spring-type terminals			
Width	mm	45	22.5	45	
Depth	mm	115			
Weight	kg	0.580	0.260	0.450	0.500
Connection type		 Screw terminals			
• Terminal screw		M 3 (standard screwdriver, size 2 and Pozidriv 2)			
• Solid	mm ²	1 x (0.5 ... 4)/2 x (0.5 ... 2.5)			
• Finely stranded with end sleeve	mm ²	1 x (0.5 ... 2.5)/2 x (0.5 ... 1.5)			
• AWG cables, solid or stranded	AWG	2 x (24 ... 16)			
• Tightening torque	Nm	0.8 ... 1.2			
Connection type		 Spring-type terminals			
• Solid	mm ²	2 x (0.25 ... 1.5)			
• Finely stranded, with end sleeves acc. to DIN 46228	mm ²	2 x (0.25 ... 1.0)			
• Finely stranded	mm ²	2 x (0.25 ... 1.5)			
• Stripped length	mm	10			
Electrical specifications					
Rated control supply voltage U_s	V	24 DC, 24/115/230 AC			
Operating range					
• AC operation	V	0.85 ... 1.1 × U_s	0.85 ... 1.1 × U_s	0.85 ... 1.1 × U_s	0.85 ... 1.1 × U_s
• DC operation	V	0.85 ... 1.1 × U_s	0.85 ... 1.2 × U_s	0.85 ... 1.1 × U_s	0.85 ... 1.1 × U_s
Measurement voltage	V	--			
Response value U_{resp}	mV	--			
Rated insulation voltage U_i					
• For control circuit	V	--			
• For outputs	V	300			
Rated impulse withstand voltage U_{imp}					
• For control circuit	V	--			
• For outputs	V	4000			
Rated power	W	3	2	3	
Frequency ranges	Hz	50/60			
Rated operational current I_e (relay outputs) at					
• AC-15 at 115 V	A	--	--	--	--
• AC-15 at 230 V	A	13/14, 23/24: 5 47/48, 57/58: 3	5	5	23/24, 33/34, 41/42: 5 13/14: 3
• DC-13 at 24 V	A	13/14, 23/24: 5 47/48, 57/58: 2	5	6	23/24, 33/34, 41/42: 5 13/14: 2
• DC-13 at 115 V	A		0.2	0.2	0.2
• DC-13 at 230 V	A		0.1	0.1	0.1
Rated operational current I_e (semiconductor outputs) at					
• DC-13 at 24 V	A	--			
• DC-13 at 230 V	A	--			

Type		3TK28 28	3TK28 30	3TK28 34	3TK28 35
Electrical specifications (continued)					
Electrical endurance	Oper. cycles	10 ⁵			
Mechanical endurance	Oper. cycles	10 ⁷			
Switching frequency z	1/h	1000			
Conventional thermal current I_{th}	A	5		6	5
Conventional thermal current I_{th}					
• 1 contact	A	--			
• 2 contacts	A	--			
• 3 contacts	A	--			
• 4 contacts	A	--			
Fusing for output contacts					
Fuse links LV HRC Type 3NA, DIAZED Type 5SB, NEOZED Type 5SE, gL/gG operational class					
• gL/gG	A	6, control voltage: 2	6	6, control voltage: 2	
• Quick	A	10	10	10	
Maximum line resistance	Ω	30		--	
Cable length from terminal to terminal	m	1000	3TK28 30-CB30:1000 3TK28 30-AJ20: 300 3TK28 30-AL20: 80	1000	--
With Cu 1.5 mm ² and 150 nF/km					
Times					
Bridging of voltage dips, supply voltage	ms	30	3TK28 30-CB30:10 3TK28 30-A.20: 35	40	
(only internal, no outputs)					
Make-time t_E					
• For automatic start typ.	ms	--	--	--	--
• For automatic start max.	ms	80	3TK28 30-CB30: 30 3TK28 30-A.20: 200	100	50
• For automatic start after mains failure typ.	ms	--	--	--	--
• For automatic start after mains failure max.	ms	--	3TK28 30-CB30: 30 3TK28 30-A.20: 200	--	--
• For monitored start typ.	ms	--	--	--	--
• For monitored start max.	ms	--	--	--	--
Release time t_R					
• For sensor typ.	ms	--	--	--	--
• For sensor max.	ms	Up to 30 adjustable	--	20	50
• For mains failure typ.	ms	--	--	--	--
• For mains failure max.	ms	100	3TK28 30-CB20: 25 3TK28 30-A.20: 80	--	--
Recovery time t_W					
• After sensor	ms	After time has elapsed	--	Min. 250	Min. 250
• After mains failure	s	Min. 1	3TK28 30-CB20: 50 3TK28 30-A.20: 120	--	--
Minimum command duration t_B					
• Sensor input	ms	Min. 25	--	--	--
• ON button	s	Min. 25	--	--	--
• Cascading input	s	--	--	--	--
Simultaneity t_G	ms	∞			
Temperatures					
Permissible ambient temperature					
• During operation	°C	-25 ... +60			
• During storage	°C	-40 ... +80			
Safety specifications					
Safety integrity level SIL CL		Stop cat. 0: 3 Stop cat. 1: 2	3	--	3
acc. to IEC 61508					
Performance level PL		--			
acc. to ISO 13849-1					
Safety category CAT		Stop cat. 0: 4 Stop cat. 1: 3	As basic unit	4	As basic unit
acc. to EN 954-1					
Type		--	--	III C	As basic unit
acc. to EN 574					
Probability of a dangerous failure					
• Per hour (PFH _D)	1/h	Stop cat. 0: 3 × 10 ⁻⁸ Stop cat. 1: 2 × 10 ⁻⁷	3 × 10 ⁻⁸	3 × 10 ⁻⁸	
• On demand (PFD)		--	--	--	
Proof-test interval T1	a	20			
Environmental data					
EMC		EN 60947-5-1			
Vibrations					
acc. to EN 60068-2-6					
• Frequency	Hz	5 .. 500			
• Amplitude	mm	0.075			
Climatic withstand capability		EN 60068-2-1, EN 60068-2-2, EN 60068-2-14, EN 60068-2-30			
Clearances in air and creepage distances		EN 60947-1			

3TK28 Safety Relays

With relay enabling circuits

Dimensional drawings

3TK28 21 to 3TK28 24, 3TK28 30 with screw terminals

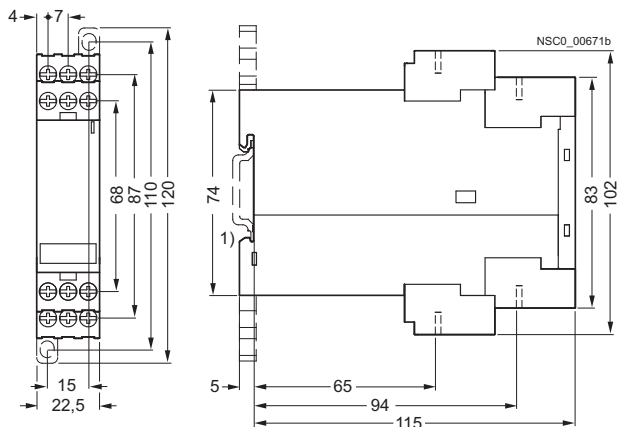

3TK28 21 to 3TK28 24, 3TK28 30 with spring-type terminals

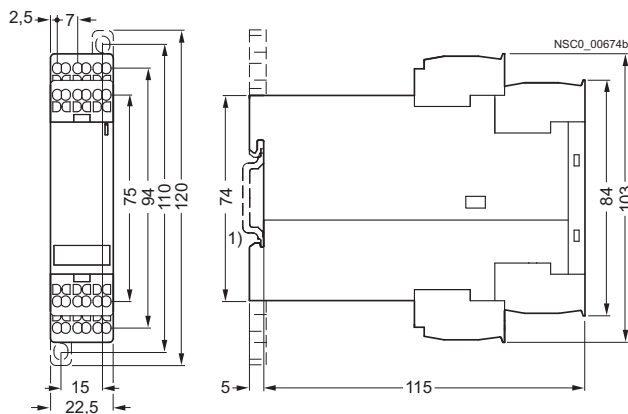

3TK28 25 up to 3TK28 28, 3TK28 34, 3TK28 35 with screw terminals

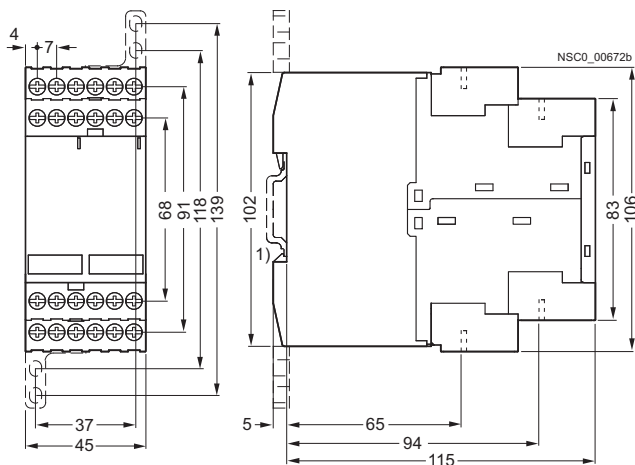

3TK28 25 to 3TK28 28, 3TK28 34, 3TK28 35 with spring-type terminals

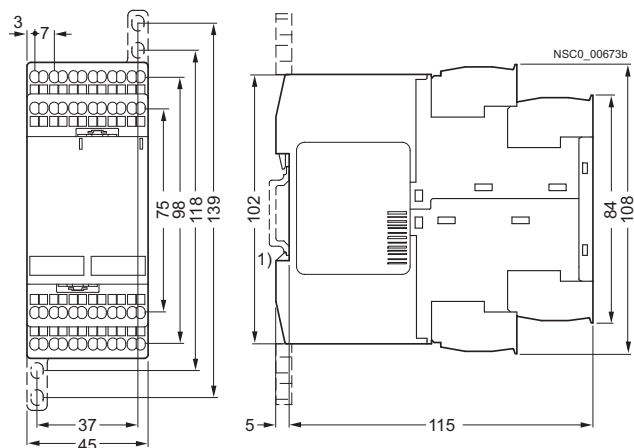

1) For standard mounting rail TH 35 according to EN 60715.

Schematics

3TK28 21

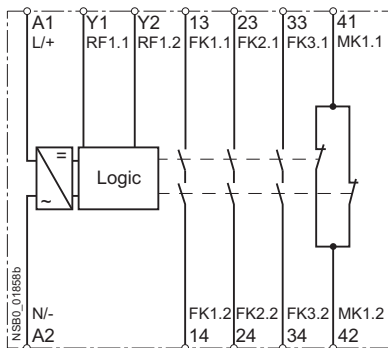

3TK28 22, 3TK28 23

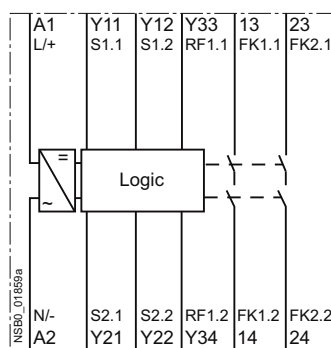

3TK28 24

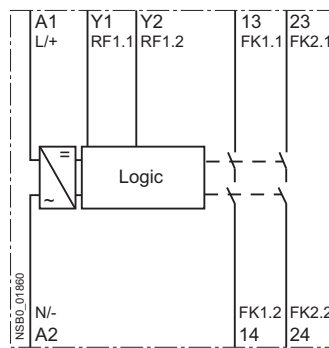

Legend

- FK_{x,x'}: Enabling circuits
- S_{x,x'}: Sensor terminals (test connectors)
- RF_{x,x'}: Feedback circuit terminals
- MK_{x,x'}: Indicating circuit terminals

Schematics

3TK28 25

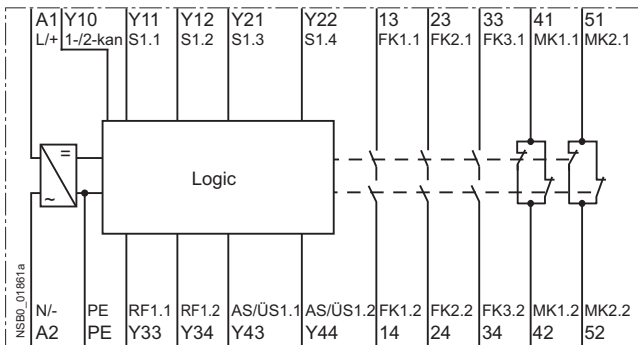

3TK28 26-.CW31/-CW32/-CW34

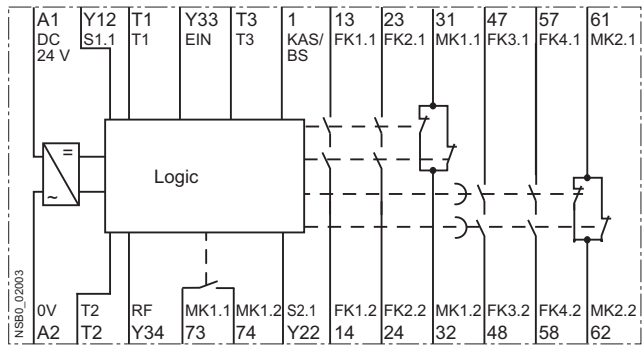

3TK28 26-.BB40

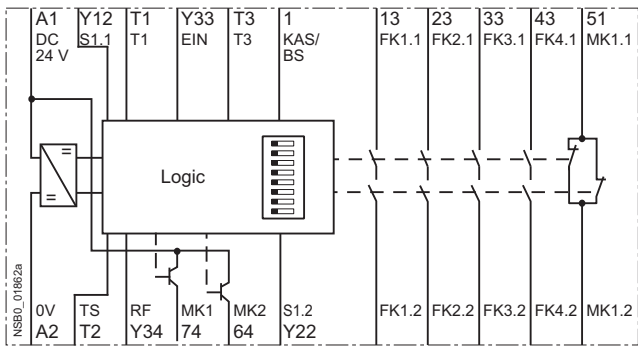

3TK28 27, 3TK28 28

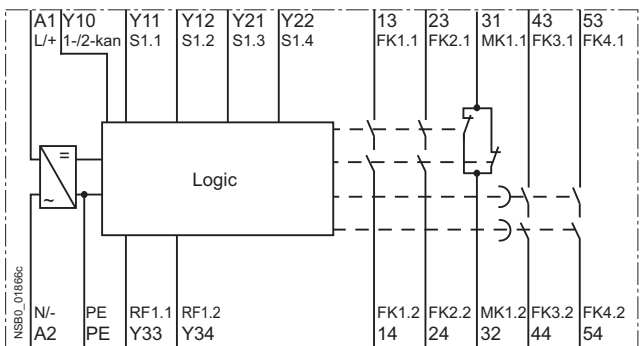

3TK28 26-.BB41/-BB42/-BB44

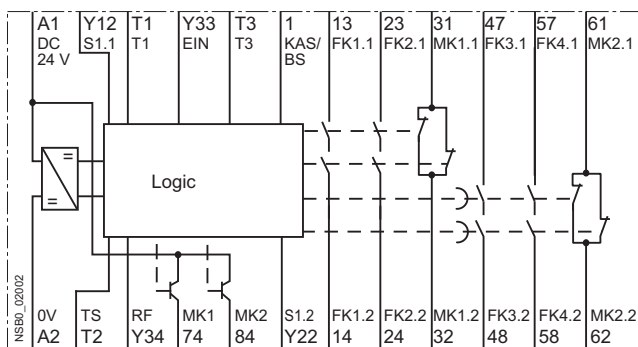

3TK28 30

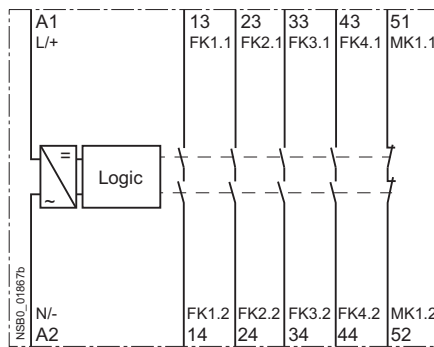

3TK28 26-.CW30

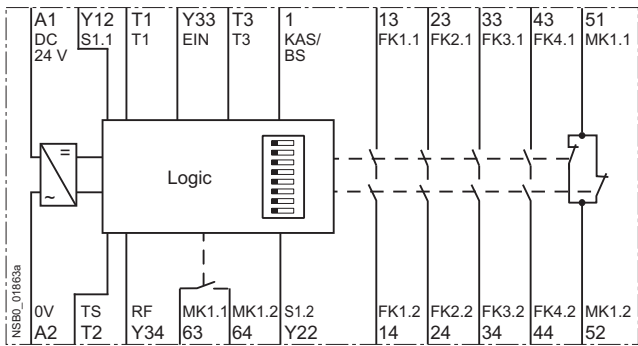

Legend

- FK_{x,x}: Enabling circuits
- S_{x,x}: Sensor terminals (test connectors)
- RF_{x,x}: Feedback circuit terminals
- MK_{x,x}: Indicating circuit terminals
- PE: PE/ground conductor terminal
- Tx: Test signal terminal
- EIN: Start signal terminal
- 1-/2-kan: Parameter terminal switchover, one/two-channel
- AS/ÜS: Parameter terminal switchover, automatic/monitored start
- KAS/BS: Terminal, cascading input/normal switching
- tv: Time-delayed outputs

3TK28 Safety Relays

With contactor relay enabling circuits

Design

The solid-state safety relays can be used in EMERGENCY-STOP devices according to EN 418 and in safety circuits according to EN 60204-1 (11.98), for example, for moving covers and protective doors. Depending on the device type and the external circuit, the maximum category that can be achieved is Category 4 of EN 954-1 or SIL 3 according to IEC 61508.

With these devices, solid-state safety relays are connected with contactor relays. The combination is supplied as a complete unit, fully wired up and tested, for snapping onto a standard mounting rail. This unit combines the advantages of a solid-state safety relay and those of contactor relays with positively-driven contacts in a single device. It has been certified by the appropriate authorities as a complete unit.

Basic units, Category 3

The 3TK28 50, 3TK28 51 and 3TK28 52 solid-state safety relays have two contactor relays snapped onto the safety solid-state unit as floating switching blocks. Three LEDs indicate the operating state and the function. During operation, all internal circuit elements are monitored cyclically for faults. Up to Category 3 according to EN 954-1 is achieved, depending on the external circuit.

Basic units, Category 4

The 3TK28 53 solid-state safety relay has two contactor relays snapped onto the safety solid-state units as floating switching blocks, as well as a safe solid-state output, a safe input for cascading and one input for normal switching duty. Three LEDs indicate the operating state and the function.

During start-up, the device runs through a self-test in which the internal electronics are checked for correct functioning. During operation, all internal circuit elements are monitored cyclically for faults.

Expansion units, namely 3TK28 30, 3TK28 56, 3TK28 57, 3RA7 11 to 3RA7 14, as well as external actuators or loads can be connected using the safe solid-state output (terminal 2). Cascading with the 3TK28 41, 3TK28 42, 3TK28 45 and 3TK28 53 safety relays as well as with the 3RA7 11 load feeder is also possible using the safe solid-state output (terminal 2).

Mounting

For snap-on mounting on TH 35 standard mounting rail according to EN 60715. Screw fixing is also possible for the devices by means of 2 additional 3RP19 03 push-in lugs.

Function

Basic units

3TK28 50 to 3TK28 52

The devices 3TK28 50 to 3TK28 52 each have one sensor input and a varying number of contactor relay enabling circuits and signaling outputs. If the signal is no longer applied to the sensor input, the enabling circuits are disconnected immediately.

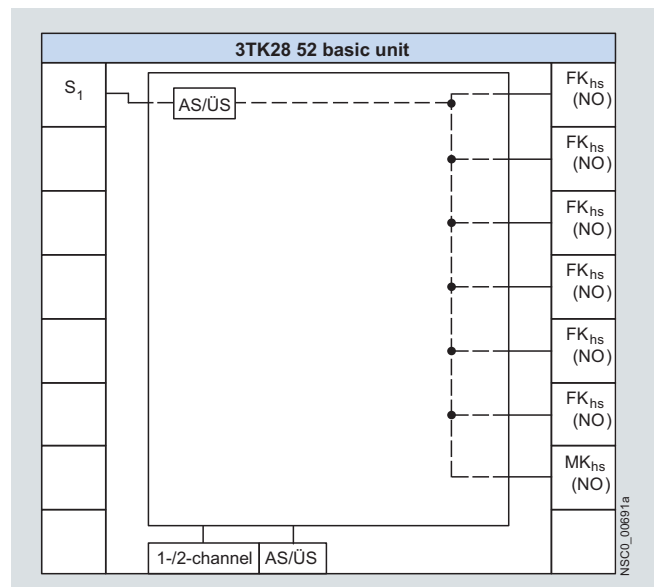
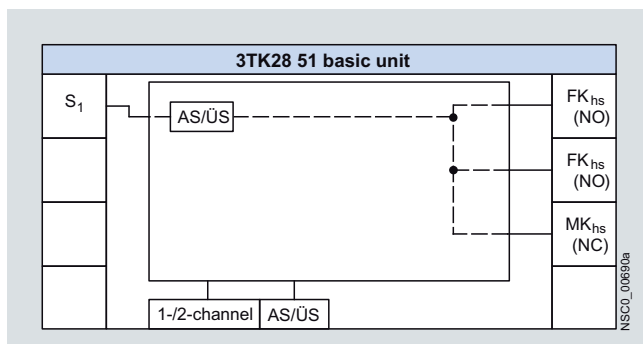
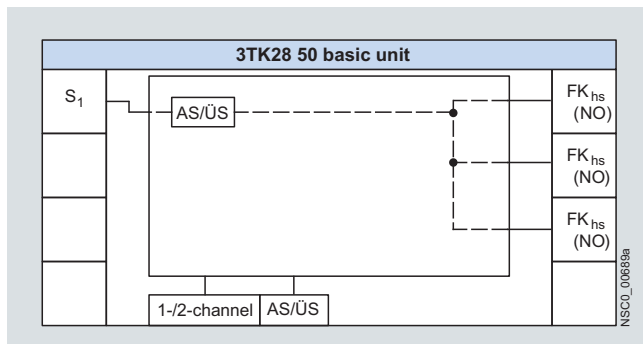

Legend

Sensor interface

S_x : Sensor input

Safety logic

AS/ÜS: Automatic or monitored start depending on the parameterization

Parameters

1-/2-channel: One-channel / two-channel sensor connection

AS/ÜS: Automatic or monitored start depending on the parameterization

Actuator interface

FK_{hs} : Enabling circuit, contactor relay (floating)

MK_{hs} : Signaling circuit, contactor relay (floating)

NO: NO contact

NC: NC contact

3TK28 Safety Relays

With contactor relay enabling circuits

Basic units

3TK28 53

The 3TK28 53 has one sensor input and one input for normal switching duty and one cascading input. On the output side is a varying number of solid-state enabling circuits or contactor relay enabling circuits. If the signal is no longer applied to one of the inputs, the enabling circuits are isolated immediately. Autostart or monitored start can be selected in the parameterization.

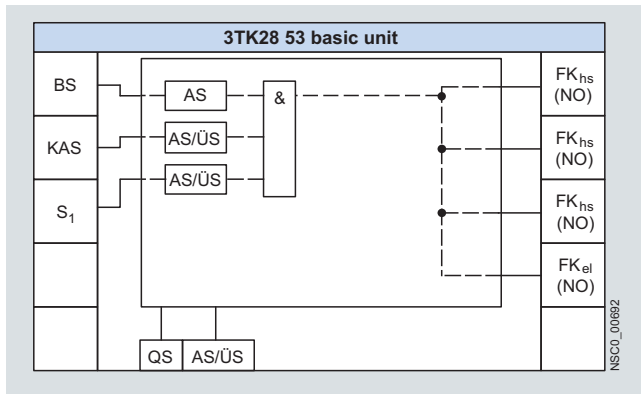

Legend

Sensor interface

S_v : Sensor input
 KAS/BS: Cascading input or normal switching duty.
 Normal switching duty: Connection of a PLC output for example.
 The enabling circuits and hence the connected loads can then be operated by the machine control.
 The safety function is on a higher level.

Safety logic

AS: Automatic start. Device starts automatically once the enabling conditions are fulfilled. If a START button is integrated in the feedback circuit, a manual start is also possible (up to Category 3 according to EN 954-1).

AS/ÜS: Automatic or monitored start depending on the parameterization

Parameters

QS: With or without crossover monitoring
 AS/ÜS: Automatic or monitored start depending on the parameterization

 Time delay, OFF-delay

Actuator interface

FK_{el} : Enabling circuit, solid-state (non-floating)
 FK_{hs} : Enabling circuit, contactor relay (floating)
 MK_{hs} : Signaling circuit, contactor relay (floating)
 NO: NO contact
 NO_{tv} : NO contact, time-delayed
 NC: NC contact

Expansion units

3TK28 56 and 3TK28 57

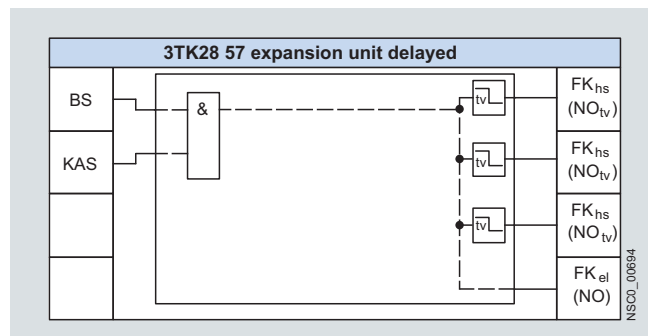
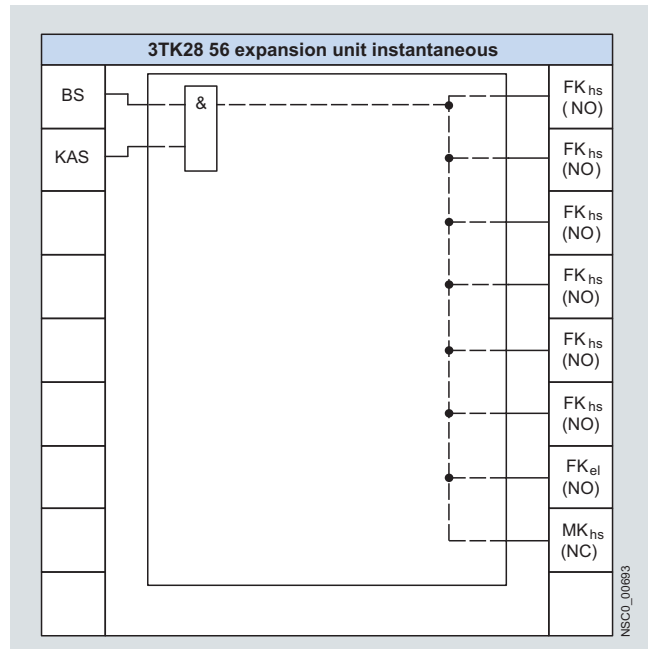

The 3TK28 56 and 3TK28 57 devices each have one one input for normal switching duty and one cascading input. On the output side is a varying number number of solid-state enabling circuits or contactor relay enabling circuits and signaling outputs. If the signal is no longer applied to one of the inputs, the enabling circuits are isolated immediately or according to the set delay time.



3TK28 Safety Relays

With contactor relay enabling circuits

Technical specifications

Type		3TK28 50	3TK28 51	3TK28 52	3TK28 53	3TK28 53-0AB1	3TK28 56	3TK28 57	
General data									
Standards		EN 60204-1, EN ISO 12100, EN 954-1, IEC 61508							
Test certificates		TÜV, UL, CSA							
Safety-oriented output contacts									
• Instantaneous FK_{rel}		3	2	6	3	6		3	
• Time-delayed $FK_{rel}(tv)$		--	--	--	--	--		--	
Safety-oriented semiconductor outputs									
• Instantaneous FK_{el}		--			1				
• Time-delay $FK_{el}(tv)$		--			--				
Signaling contacts MK_{rel}		--	1		--	1		--	
Semiconductor signaling outputs MK_{rel}		--							
Sensor inputs S		1					--		
Cascading inputs KAS/BS		--			2				
Degree of protection acc. to EN 60529									
• Enclosure		IP20							
• Terminals		IP20							
Shock resistance sine wave	g/ms	5/11					8/10 and 15/5		
Permissible mounting positions		Any							
Touch protection		Finger-safe							
acc. to EN 61140 or EN 60900									
Height	mm	89							
Width	mm	90							
Depth	mm	112		150	112		150	112	
Weight	kg	0.850			0.750				
Connection type		 Screw terminals							
• Terminal screw		M 3 (standard screwdriver, size 2 and Pozidriv 2)							
• Solid	mm ²	1 x (0.2 ... 2.5)/2 x (0.2 ... 1.0)							
• Finely stranded with end sleeve	mm ²	1 x (0.25 ... 2.5)/2 x (0.25 ... 1.0)							
• AWG cables, solid or stranded	AWG	2 x (24 ... 12)							
• Tightening torque	Nm	0.8 ... 1.2							
Connection type		 Spring-type terminals							
• Solid	mm ²	2 x (0.2 ... 2.5)							
• Finely stranded, with end sleeves	mm ²	2 x (0.25 ... 2.5)							
acc. to DIN 46228									
• Finely stranded	mm ²	2 x (0.25 ... 2.5)							
• Stripped length	mm	10							
Electrical specifications									
Rated control supply voltage U_s	V	24 DC, 24/115/230 AC			24 DC				
Measurement voltage	V	--							
Response value U_{resp}	V	--							
Operating range									
• AC operation	V	0.9 ... 1.15 x U_s			--				
• DC operation	V	0.85 ... 1.1 x U_s			0.85 ... 1.1 x U_s				
Rated insulation voltage U_i									
• For control circuit	V	50							
• For outputs	V	690							
Rated impulse withstand voltage U_{imp}									
• For control circuit	V	500							
• For outputs	V	6000							
Rated power at U_s	W	8.5							
Frequency ranges	Hz	50/60			--				
Rated operational current I_e (relay outputs) at									
• AC-15 at 115 V	A	--		--	--			--	
• AC-15 at 230 V	A	6		6	--			--	
• DC-13 at 24 V	A	10		10, Auxiliary switch blocks: 6	10			10, Auxiliary switch blocks: 6	
• DC-13 at 115 V	A	--		--	--			--	
• DC-13 at 230 V	A	--		--	--			--	
Rated operational current I_e (semiconductor outputs) at									
• DC-15 at 24 V	A	--							
• DC-15 at 230 V	A	--							

Type		3TK28 50	3TK28 51	3TK28 52	3TK28 53	3TK28 53-0AB1	3TK28 56	3TK28 57
Electrical specifications (continued)								
Electrical endurance	Operating cycles	See "3RH1 Characteristic Curves"						
Mechanical endurance	Operating cycles	3 x 10 ⁷						
Switching frequency z		10 ³						
Conventional thermal current I_{th}	A	--						
Conventional thermal current I_{th}								
• 1 contact	A	--						
• 2 contacts	A	--						
• 3 contacts	A	--						
• 4 contacts	A	--						
Fusing for output contacts								
Fuse links LV HRC Type 3NA, DIAZED Type 5SB, NEOZED Type 5SE								
• gL/gG	A	10						
• Quick	A	--						
Maximum line resistance	Ω	250			500			
Cable length from terminal to terminal With Cu 1.5 mm ² and 150 nF/km	m	2000						
Times								
Bridging of voltage dips, supply voltage (only internal, no outputs)	ms	5						
Make-time t_E								
• For automatic start typ.	ms	100			60		--	
• For automatic start max.	ms	200			100		--	
• For automatic start after mains failure typ.	ms	350			6000		6000	
• For automatic start after mains failure max.	ms	500			7000		7000	
• For monitored start typ.	ms	60			60		--	
• For monitored start max.	ms	100			100		--	
Release time t_R								
• For sensor typ.	ms	30			50		--	
• For sensor max.	ms	50			60		300 adjustable	
• For mains failure typ.	ms	100			120		120	
• For mains failure max.	ms	120			120		120	
Recovery time t_W								
• After sensor	ms	20			500			
• After mains failure	s	0.02			7			
Minimum command duration t_B								
• Sensor input	ms	20			45		--	
• ON button	s	20			0.2 ... 5		--	
• Cascading input	ms	20			45		45	
Simultaneity t_G	ms	∞						
Temperatures								
Permissible ambient temperature								
• During operation	°C	-25 ... +60						
• During storage	°C	-40 ... +80						
Safety specifications								
Safety integrity level SIL CL acc. to IEC 61508		2			--			
Performance level PL acc. to ISO 13849-1		--						
Safety category CAT acc. to EN 954-1		3			4		As basic unit	
Type acc. to EN 574		--						
Probability of a dangerous failure								
• Per hour (PFH _D)	1/h	1.52 x 10 ⁻⁸			5 x 10 ⁻¹¹		9.8 x 10 ⁻¹¹	
• On demand (PFD)	--	--			--		--	
Proof-test interval T1	a	10						
Environmental data								
EMC		IEC 60947-5-1, IEC 60000-4-3, IEC 60000-4-5, IEC 60000-4-6						
Vibrations acc. to EN 60068-2-6								
• Frequency	Hz	5 ... 500						
• Amplitude	mm	0.075						
Climatic withstand capability		EN 60068-2-78						
Clearances in air and creepage distances		EN 60947-1						

3TK28 Safety Relays

With contactor relay enabling circuits

Dimensional drawings

3TK28 50, 3TK28 51, 3TK28 53, 3TK28 57
with screw terminals

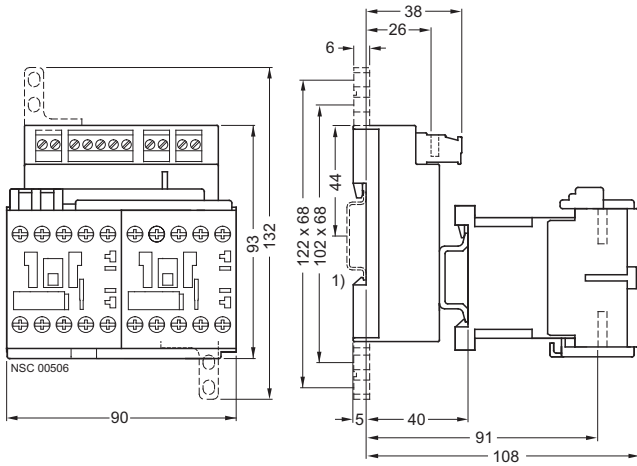

3TK28 50, 3TK28 51, 3TK28 53, 3TK28 57
with spring-type terminals

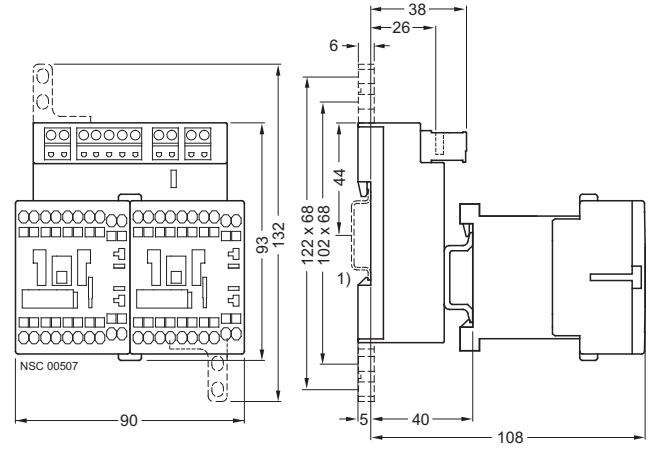

3TK28 52, 3TK28 56 with screw terminals

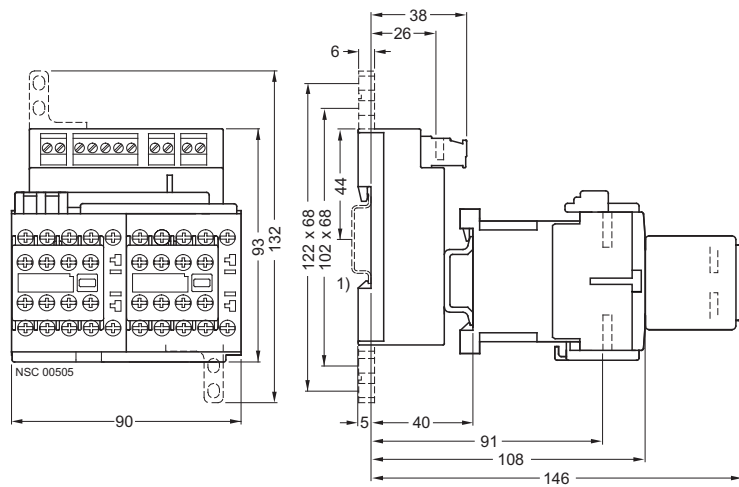

3TK28 52, 3TK28 56 with spring-type terminals

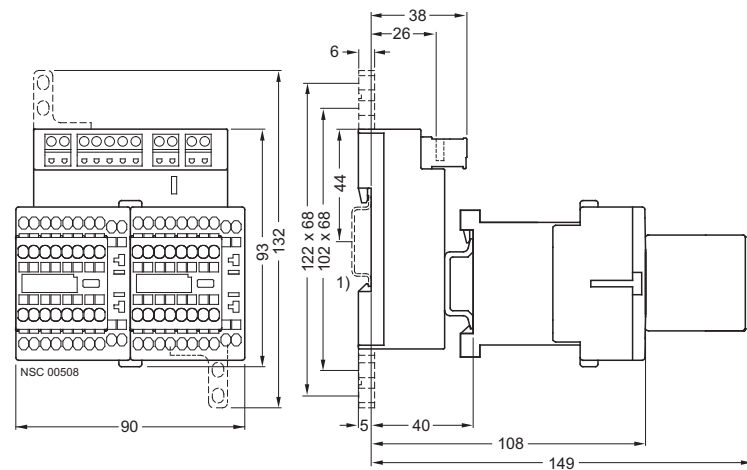

1) For standard mounting rail TH 35 according to EN 60715.

Design

The 3TK28 10 safety relays with special functions operate with internal contactor relays with positively-driven contacts.

In a redundant circuit, operation of the internal controls is monitored. If a safety relay fails, it will always switch to the de-energized and consequently safe state. The fault is detected and the safety relay can no longer be switched on.

Enabling contacts (FK)

Safety related operation must be performed by safe output contacts, known as enabling contacts. Enabling contacts are always NO contacts and switch without delay.

Signaling contacts (MK)

NC contacts are used as signaling contacts but they are not permitted to perform functions with relevance for safety. An enabling contact can also be used as a signaling contact. A signaling contact cannot, however, be used as an enabling contact.

Expansion units

If the enabling contacts of the basic unit are inadequate, expansion units can be used. An expansion unit has 4 enabling contacts. Expansion units are not allowed to be operated separately in safety-related switching circuits; they must be combined with a basic unit. One enabling contact of the basic unit is required for connecting an expansion unit. The category of a control system with expansion unit corresponds to that of the basic unit.

Function

3TK28 10-0 standstill monitor

The 3TK2810-0 safe standstill monitor measures a voltage of the decelerating motor, which is induced by residual magnetism, at 3 terminals of the stator winding. When the induction voltage approximates to 0, the monitor interprets this to mean that the motor has stopped and the output relay is activated. To be able to adapt the monitor to different motors and applications, it is possible to adjust the voltage threshold U_{an} below which the 3TK2810-0 detects a stoppage. Also adjustable is the length of time over which U_{an} must be undershot in order for a stoppage to be detected and the output circuit enabled (downtime t_s).

The device also detects wire breaks between the measuring inputs L1/L2/L3. If a wire break is detected, the output relay will adopt the safe position (the same as with a running motor).

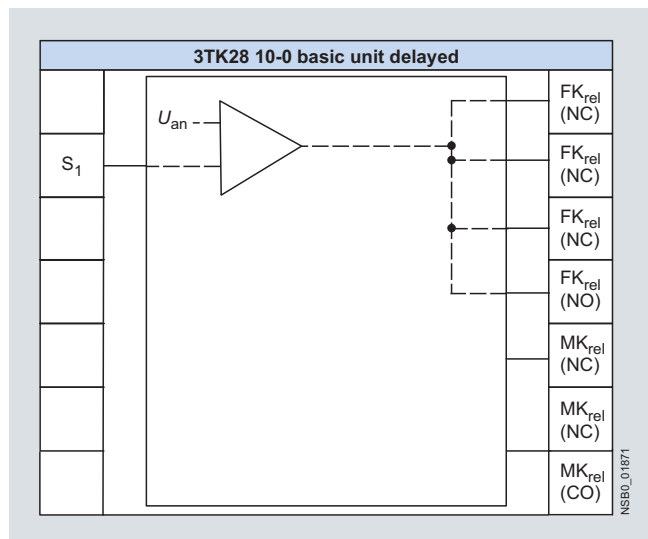

Legend

Sensor interface

S_x : Sensor input



Actuator interface

FK_{rel}: Enabling circuit, relay contact (floating)
 MK_{rel}: Signaling circuit, solid-state output (non-floating)
 MK_{rel}: Signaling circuit, relay contact (floating)
 NO: NO contact
 NC: NC contact
 CO: Changeover contact

3TK28 Safety Relays

With special functions

Technical specifications

Type	3TK28 10	
General data		
Standards	EN 60204-1, EN ISO 12100, EN 954-1, IEC 61508	
Test certificates	TÜV, UL, CSA	
Safety-oriented output contacts		
• Instantaneous FK_{rel}	4	
• Time-delayed $FK_{rel(tv)}$	--	
Safety-oriented semiconductor outputs		
• Instantaneous FK_{el}	--	
• Time-delay $FK_{el(tv)}$	--	
Signaling contacts MK_{rel}	1	
Semiconductor signaling outputs MK_{rel}	2	
Sensor inputs S	1	
Cascading inputs KAS/BS	--	
Degree of protection acc. to EN 60529		
• Enclosure	IP40	
• Terminals	IP20	
Shock resistance sine wave	<i>g/ms</i>	8/10
Permissible mounting positions	Any	
Touch protection	Finger-safe	
acc. to EN 61140 or EN 60900		
Height	mm	106: screw terminals; 108: spring-type terminals
Width	mm	45
Depth	mm	116
Weight	kg	0.500
Connection type	 Screw terminals	
• Terminal screw		M 3 (standard screwdriver, size 2 and Pozidriv 2)
• Solid	mm ²	1 x (0.5 ... 4)/2 x (0.5 ... 2.5)
• Finely stranded with end sleeve	mm ²	1 x (0.5 ... 2.5)/2 x (0.5 ... 1.5)
• AWG cables, solid or stranded	AWG	2 x (24 ... 16)
• Tightening torque	Nm	0.8 ... 1.2
Connection type	 Spring-type terminals	
• Solid	mm ²	2 x (0.25 ... 1.5)
• Finely stranded, with end sleeves acc. to DIN 46228	mm ²	2 x (0.25 ... 1.0)
• Finely stranded	mm ²	2 x (0.25 ... 1.5)
Electrical specifications		
Rated control supply voltage U_s	V	24 DC, 230/400 AC
Operating range		
• AC operation	V	0.8 ... 1.1 x U_s
• DC operation	V	0.9 ... 1.15 x U_s
Measurement voltage	V	Max. 690
Response value U_{resp}	V	20 ... 400 adjustable
Rated insulation voltage U_i		
• For control circuit	V	300
• For outputs	V	690
Rated impulse withstand voltage U_{imp}		
• For control circuit	V	6/4
• For outputs	V	6
Rated power at U_s	W	3
Frequency ranges	Hz	50/60
Rated operational current I_e (relay outputs) at		
• AC-15 at 115 V	A	--
• AC-15 at 230 V	A	3 (NO contacts); 2 (NC contacts)
• DC-13 at 24 V	A	2
• DC-13 at 115 V	A	--
• DC-13 at 230 V	A	--
Rated operational current I_e (semiconductor outputs) at		
• DC-13 at 115 V	A	0.1
• DC-13 at 230 V	A	--
Electrical endurance	Operat- ing cycles	2×10^5
Mechanical endurance	Operat- ing cycles	5×10^7
Switching frequency z	1/h	1200

Technical specifications

Type	3TK28 10	
Electrical specifications (continued)		
Conventional thermal current I_{th}	A	5, summation current max. 8
Conventional thermal current I_{th}		
• 1 contact	A	5
• 2 contacts	A	5
• 3 contacts	A	5
• 4 contacts	A	--
Fusing for output contacts		
Fuse links LV HRC Type 3NA, DIAZED Type 5SB, NEOZED Type 5SE, gL/gG operational class		
• gL/gG		--
• Quick	A	5
Maximum line resistance		
	Ω	--
Cable length from terminal to terminal		
With Cu 1.5 mm ² and 150 nF/km		
Times		
Release time t_R		
• For sensor typ.	ms	--
• For sensor max.	ms	6 adjustable
• For mains failure typ.	ms	--
• For mains failure max.	ms	--
Simultaneity t_G		
	ms	∞
Temperatures		
Permissible ambient temperature		
• During operation	°C	-25 ... +60
• During storage	°C	-40 ... +75
Safety specifications		
Safety integrity level SIL CL		
acc. to IEC 61508		3
Performance level PL		
acc. to ISO 13849-1		e
Safety category CAT		
acc. to EN 954-1		4
Probability of a dangerous failure		
• Per hour (PFH _D)	1/h	1.49 × 10 ⁻⁹
• On demand (PFD)		--
Proof-test interval T1		
	a	20

3TK28 Safety Relays

With special functions

Dimensional drawings

3TK28 10 with screw terminals

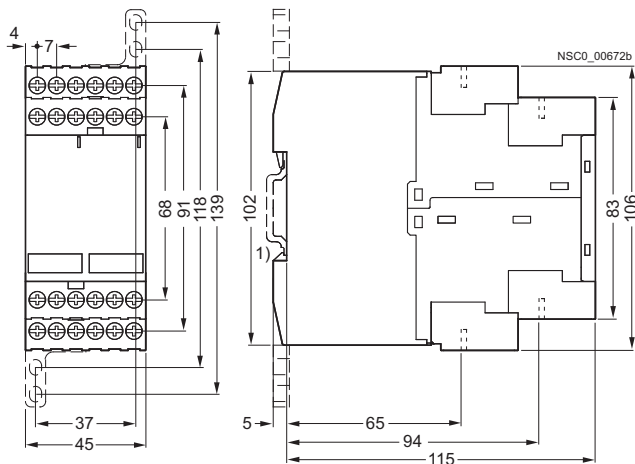

3TK28 10 with spring-type terminals

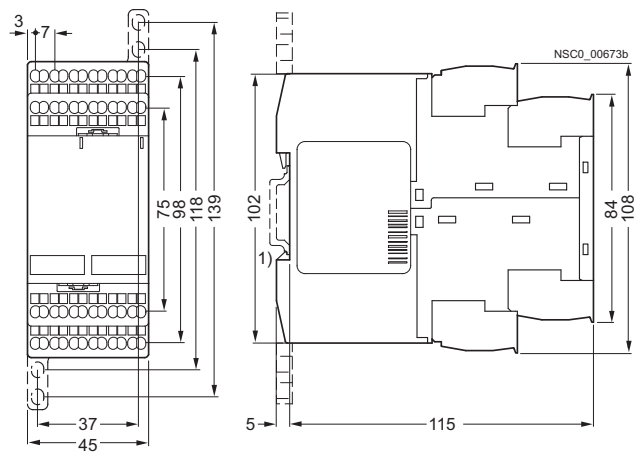

1) For standard mounting rail TH 35 according to EN 60715.

Schematics

3TK28 10-0BA0.

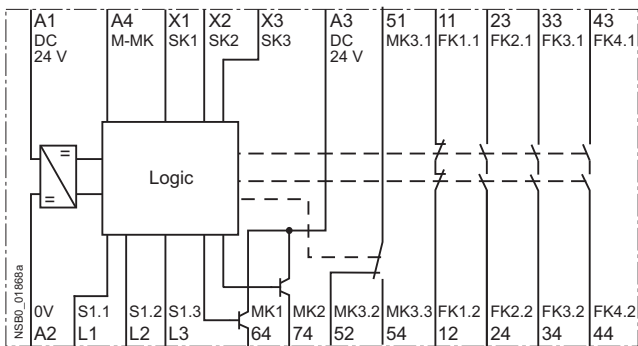

3TK28 10-0JA0.

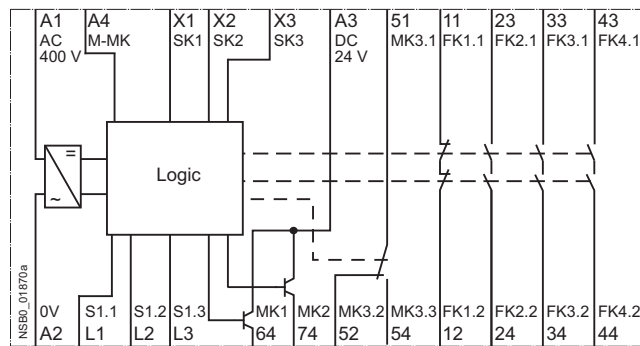

3TK28 10-0GA0.

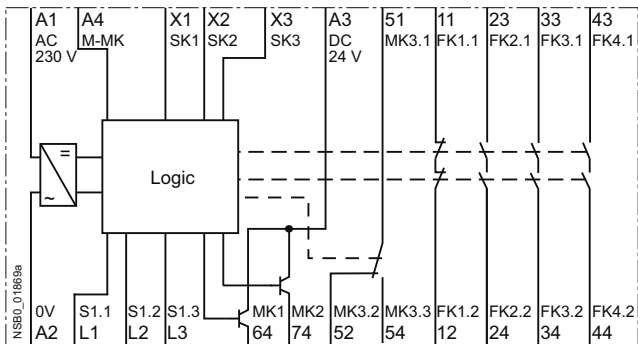

Legend

- FK_{x.x}: Enabling circuits
- MK_{x.x}: Indicating circuit terminals
- M-MK: Ground signaling circuits
- S_{x.x}: Sensor terminals (test connectors)
- SK_x: Control terminals

Overview

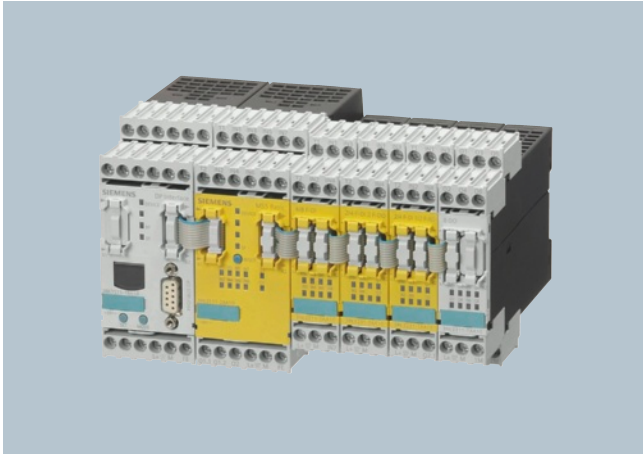

The 3RK3 modular safety system (MSS) is a freely parameterizable modular safety relay. Depending on the type of external connection, safety-orientated applications up to Category 4 according to EN 954-1, Performance Level e according to ISO 13849-1 and SIL3 according to IEC 62061 can be realized.

The modular safety relay permits several safety applications to be interconnected. The safety functions are easily created on the PC using a graphic parameterizing tool. For example, disconnection ranges can be set and other dependencies defined.

With additional safety-oriented expansion modules the system is flexibly adapted to the required safety applications.

The MSS comprises the following system components:

- Central module
- Expansion modules
- Interface module
- Parameterization software
- Accessories

The comprehensive error and status diagnostics provides the possibility of finding errors in the system and localizing signals from sensors. Plant downtimes can be reduced as the result.

Optional interface modules send the diagnostics data to higher-level bus systems (e. g. PROFIBUS DP). These data are then available for further processing in the automation system.

Design

General

The 3RK3 modular safety system comprises the following components:

- Central module
- Expansion modules and
- Interface module

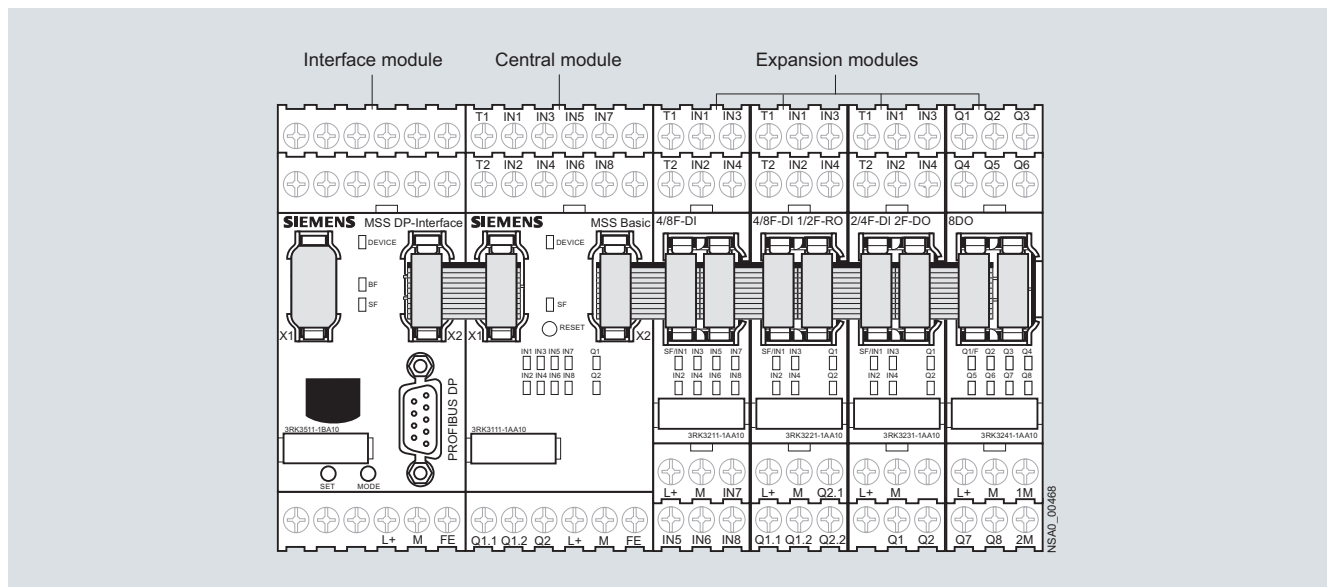

Typical design of the MSS

3RK3 Modular Safety Systems

Modules

Central module



The 3RK3 Basic central module is the basic unit of the MSS modular safety system for every system configuration. It controls the expansion modules and supplies data to the DP interface. The central module also stores the parameterization which performs logic operations for input signals and output signals.

The 3RK3 Basic central module has:

- 8 safety-oriented, freely configurable sensor inputs
- 1 safety-oriented two-channel relay output
- 1 safety-oriented two-channel solid-state output

Up to 7 expansion modules can be connected to the 3RK3 Basic central module.

Data exchange with the higher-level automation system takes place through an additional bus module (DP interface) or through PROFIBUS. The 3RK3 Basic central module can be parameterized with the MSS ES engineering software.

Expansion modules

Using expansion modules, the functional scope of the MSS can be flexibly adapted to the requirements of the application. Expansion modules are offered as safety-oriented and standard input modules, output modules and mixed modules. The module types can be combined as required.

4/8 F-DI expansion modules

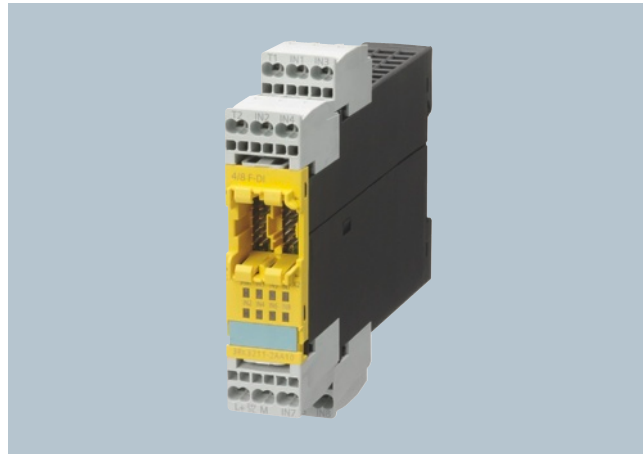

The 4/8 F-DI expansion module has only safety-oriented inputs. With single-channel connection of the sensors, 8 different sensors can be connected. For two-channel connection, two inputs are grouped per sensor. It is thus possible to connect 4 different sensors. The sensor connection types can be mixed on the module.

The 4/8 F-DI expansion module has:

- 8 single-channel inputs

2/4 F-DI 1/2 F-RO



The 2/4F-DI 1/2 F-RO expansion module has safety-oriented inputs and outputs. With single-channel connection of the sensors, 4 different sensors can be connected. For two-channel connection, two inputs are grouped per sensor. It is thus possible to connect 2 different sensors. The 2/4F-DI 1/2 F-RO expansion module has 2 safety-oriented relay outputs in single-channel configuration. If a two-channel output is required, the relay outputs can be connected in series. The sensor connection types can be mixed on the module.

The 2/4 F-DI 1/2 F-RO expansion module has:

- 4 single-channel inputs
- 2 single-channel relay outputs

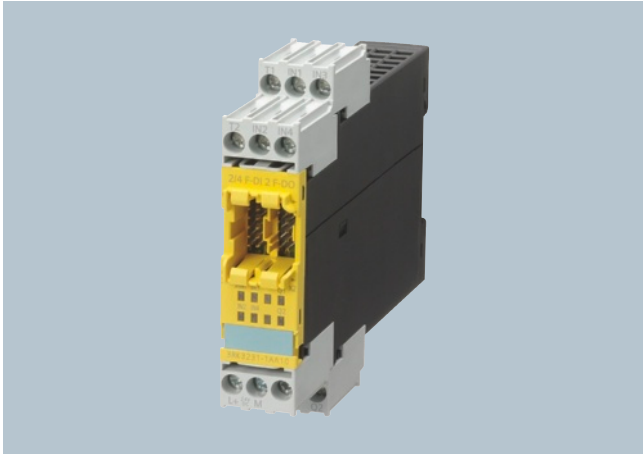
Expansion modules (continued)2/4 F-DI 2 F-DO

The 2/4F-DI 2 F-DO expansion module has safety-oriented inputs and outputs. With single-channel connection of the sensors, 4 different sensors can be connected. For two-channel connection, two inputs are grouped per sensor. It is thus possible to connect 2 different sensors. The 2/4F-DI 1/2 F-DO expansion module has 2 safety-oriented solid-state outputs in two-channel configuration. The sensor connection types can be mixed on the module.

The 2/4 F-DI 2 F-DO expansion module has:

- 4 single-channel inputs
- 2 two-channel solid-state outputs

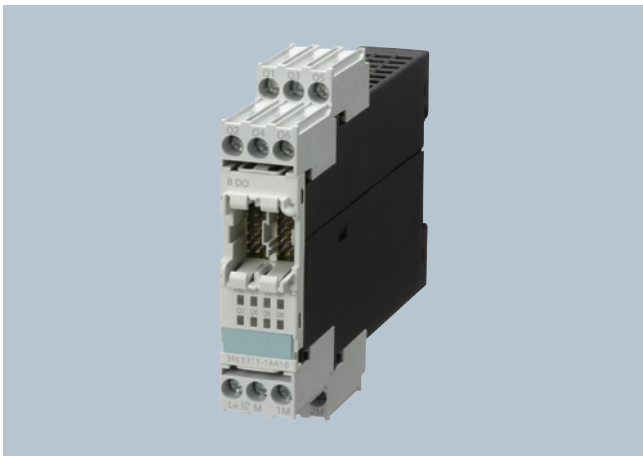
8 DO

The 8 DO expansion module has standard outputs (signaling outputs). No safety-oriented disconnection is allowed through these outputs.

The 8 DO expansion module has:

- 8 single-channel solid-state standard outputs.

DP-Interface interface modules

The bus module (DP-Interface) is used for transferring diagnostics data and device status data to a higher-level PROFIBUS network. Here these exclusively non-safety-oriented data can be evaluated in the PLC or a B&B system.

The MSS supports among other things:

- Baud rates up to 12 Mbit/s
- Automatic baud rate detection
- Cyclic services (DPV0) and acyclic services (DPV1)
- Exchange of 32-bit cyclic data
- Diagnostics using data record invocations

The bus module is integrated in the PROFIBUS network using a GSD. This is a standardized, vendor-independent specification with which the bus module can be integrated in practically all automation systems.

3RK3 Modular Safety Systems

Modules

Function

The 3RK3 modular safety system can be used for all safety-related applications in the manufacturing industry and offers the following functions:

Function	Description
Monitoring functions	
EMERGENCY-STOP	With the EMERGENCY-STOP function, signals from EMERGENCY-STOP control devices with positive-opening contacts are evaluated.
Protective door monitoring	With the protective door function, signals from protective doors or protective flaps with positive-opening contacts a combination of NC and NO contacts are evaluated.
BWS monitoring (non-contact protective devices)	With the BWS function, signals from e. g. light curtains and laser scanners are evaluated.
Operating mode selector switches	With the operating mode selector switch function, signals from an operating mode selector switch with NO contacts are evaluated. Up to 5 operating modes can be defined. The operating mode to be implemented can be freely configured in the downstream logic.
Switching mats	With the switching mat function, signals from switching mats with NC contacts or crossover monitoring are evaluated.
Two-hand operator control	With the two-hand operator control function, signals from a two-hand operator control device are evaluated.
Approval switches	With the OK button function, signals from OK buttons with NO contact are evaluated.
Logic operation functions	
AND, OR, XOR, NAND, NOR, negation (NEG), flip-flop (FF-RS)	
Counter functions	
Counter 0 -> 1	The safety relay supports the counting function "counter 0 -> 1". The count value is changed only when there is a positive edge at the count inputs. The current count value can be counted forwards or backwards through one own count input each.
Counter 1 -> 0	The safety relay supports the counting function "For negative edge 1 -> 0". The count value is changed only when there is a negative edge. The current count value can be counted forwards or backwards through one own count input each.
Counter 0 -> 1/1 -> 0	The safety relay supports the counting function "For both edges". The count value is changed both when there is a positive edge and when there is a negative edge. The current count value can be counted forwards or backwards through one own count input each.
Time functions	
ON delay, On delay (trigger), passing make contact, passing make contact (trigger), OFF delay, OFF delay (trigger), clock-pulsing	
Start functions	
Manual and automatic start	
Output functions	
Standard outputs and fail-safe outputs can be actuated.	

Technical specifications

General data		
<i>Device data</i>		
Shock resistance (sine pulse)	g/ms	15/11
Touch protection acc. to EN 61140 or EN 60529		IP20
Permissible mounting position		Vertical mounting surface (+10°/-10°), deviating mounting positions are permitted for reduced ambient temperature
Minimum distances		For heat dissipation through convection from the devices 25 mm to the ventilation openings (top and bottom)
Permissible ambient temperature		
• During operation	°C	-20 ... +60
• Storage and transport	°C	-40 ... +85
Installation height above sea level	m	2000
<i>Safety specifications</i>		
SIL integrity level SIL CL acc. to IEC 61508		3
Performance level PL acc. to ISO 13849-1		e
Safety category CAT acc. to EN 954-1		4
Type acc. to EN 574		III C
Proof-test interval T1		20 years
<i>Environmental data</i>		
EMC interference immunity		IEC 60947-5-1
Vibrations		
• Frequency	Hz	5 ... 500
• Amplitude	mm	0.75
Climatic withstand capability		EN 60068-2-78
Central module		
<i>Device data</i>		
Number of sensor inputs (1-channel)		8
Number of test outputs		2
Number of outputs		1 relay output, two-channel 1 solid-state output, two-channel
Dimensions H x W x D	mm	111 x 45 x 124 screw terminals; 113 x 45 x 124 spring-type terminals
Weight	g	300
<i>Electrical specifications</i>		
Rated control supply voltage U_s acc. to IEC 61131-2	V	24 DC Device current supply through a power supply unit acc. to IEC 60 536 safety class (SELV or PELV)
Operating range		0.85 ... 1.15 x U_s
Rated insulation voltage U_i	V	300
Rated impulse voltage U_{imp}	kV	4
Total current input	mA	185
Rated power at U_s	W	4.5
Utilization category acc. to EN 60947-5-1 (relay outputs)		
• AC15 at 230 V	A	2
• DC13 at 24 V (semiconductor outputs)	A	1
• DC13 at 24 V	A	1.5
Mechanical endurance during normal duty		10 x 10 ⁶ operating cycles (relays)
Switching frequency z at rated operational current	1/h	1000
Conventional thermal current I_{th}	A	2/1.5
Fusing for output contacts		
Fuse links LV HRC Type 3NA, DIAZED Type 5SB, NEOZED Type 5SE		
• gL/gG operational class	A	4
• Operational class quick	A	6
<i>Safety specifications</i>		
Probability of a dangerous failure		
• Per hour (PFH _d)	1/h	5.14 x 10 ⁻⁹
• On demand (PFD)	1/h	1.28 x 10 ⁻⁵
<i>Parameters for cables</i>		
Line resistance	Ω	100
Cable length from terminal to terminal With Cu 1.5 mm ² and 150 nF/km	m	1000
Conductor capacity	nF	330

3RK3 Modular Safety Systems

Modules

4/8F-DI expansion modules

Device data

Number of sensor inputs (1-channel)		8
Number of test outputs		2
Dimensions H x W x D	mm	111 x 22.5 x 124 screw terminals; 113 x 22.5 x 124 spring-type terminals
Weight	g	160

Electrical specifications

Rated control supply voltage U_s acc. to IEC 61131-2	V	24 DC $\pm 15\%$
Operating range		0.85 ... 1.15 x U_s
Rated insulation voltage U_i	V	50
Rated impulse voltage U_{imp}	V	500
Total current input	mA	60
Rated power at U_s	W	2.5

Safety specifications

Probability of a dangerous failure		
• Per hour (PFH _d)	1/h	1.89×10^{-9}
• On demand (PFD)	1/h	4.29×10^{-6}

Parameters for cables

Line resistance	Ω	100
Cable length from terminal to terminal With Cu 1.5 mm ² and 150 nF/km	m	1000
Conductor capacity	nF	330

2/4F-DI 1/2F-RO expansion modules

Device data

Number of sensor inputs (1-channel)		4
Number of test outputs		2
Number of outputs		2 relay outputs, single-channel
Dimensions H x W x D	mm	111 x 22.5 x 124 screw terminals; 113 x 22.5 x 124 spring-type terminals
Weight	g	160

Electrical specifications

Rated control supply voltage U_s acc. to IEC 61131-2	V	24 DC $\pm 15\%$
Operating range		0.85 ... 1.15 x U_s
Rated insulation voltage U_i	V	50
Rated impulse voltage U_{imp}	V	500
Total current input	mA	85
Rated power at U_s	W	2

Utilization category acc. to EN 60947-5-1

• AC15 at 230 V	A	2
• DC13 at 24 V	A	1

Mechanical endurance during normal duty		10×10^6 operating cycles (relays)
---	--	--

Switching frequency z at rated operational current	1/h	1000
--	-----	------

Continuous thermal current I_{th}	A	1
-------------------------------------	---	---

Safety specifications

Probability of a dangerous failure		
• Per hour (PFH _d)	1/h	3.79×10^{-9}
• On demand (PFD)	1/h	5.85×10^{-6}

Parameters for cables

Line resistance	Ω	100
Cable length from terminal to terminal with Cu 1.5 mm ² and 150 nF/km	m	1000
Conductor capacity	nF	330

2/4F-DI 2F-DO expansion modules

<i>Device data</i>		
Number of sensor inputs (1-channel)		4
Number of test outputs		2
Number of outputs		2 solid-state outputs, two-channel
Dimensions H x W x D	mm	111 x 22.5 x 124 screw terminals; 113 x 22.5 x 124 spring-type terminals
Weight	g	160
<i>Electrical specifications</i>		
Rated control supply voltage U_s acc. to IEC 61131-2	V	24 DC \pm 15 %
Operating range		0.85 ... 1.15 x U_s
Rated insulation voltage U_i	V	50
Rated impulse voltage U_{imp}	V	500
Total current input	mA	85
Rated power at U_s	W	2
Utilization category acc. to EN 60947-5-1 • DC13 at 24 V	A	1
Switching frequency z at rated operational current	1/h	1000
Conventional thermal current I_{th}	A	1
<i>Safety specifications</i>		
Probability of a dangerous failure • Per hour (PFH _d) • On demand (PFD)	1/h 1/h	2.7×10^{-9} 8.34×10^{-6}
<i>Parameters for cables</i>		
Line resistance	Ω	100
Cable length from terminal to terminal With Cu 1.5 mm ² and 150 nF/km	m	1000
Conductor capacity	nF	330

8DO expansion modules

<i>Device data</i>		
Number of outputs		8
Dimensions H x W x D	mm	111 x 22.5 x 124 screw terminals; 113 x 22.5 x 124 spring-type terminals
Weight	g	160
<i>Electrical specifications</i>		
Rated control supply voltage U_s acc. to IEC 61131-2	V	24 DC \pm 15 %
Operating range		0.85 ... 1.15 x U_s
Rated insulation voltage U_i	V	50
Rated impulse voltage U_{imp}	V	500
Total current input	mA	60
Rated power at U_s	W	1.5
Utilization category acc. to EN 60947-5-1 (relay outputs) • DC13 at 24 V	A	0.5
Switching frequency z at rated operational current	1/h	1000
Continuous thermal current I_{th}	A	1

Interface module

<i>Device data</i>		
Communication		32-bit cyclic data can be exchanged by PLC (DPV0); acyclic communication through DPV1
Dimensions H x W x D	mm	111 x 45 x 124 screw terminals; 113 x 45 x 124 spring-type terminals
Weight	g	270
<i>Electrical specifications</i>		
Rated control supply voltage U_s acc. to IEC 61131-2	V	24 DC \pm 15 %
Operating range		0.85 ... 1.15 x U_s
Rated insulation voltage U_i	V	50
Rated impulse voltage U_{imp}	V	500

3RK3 Modular Safety Systems

Modules

Dimensional drawings

Central module with screw terminals

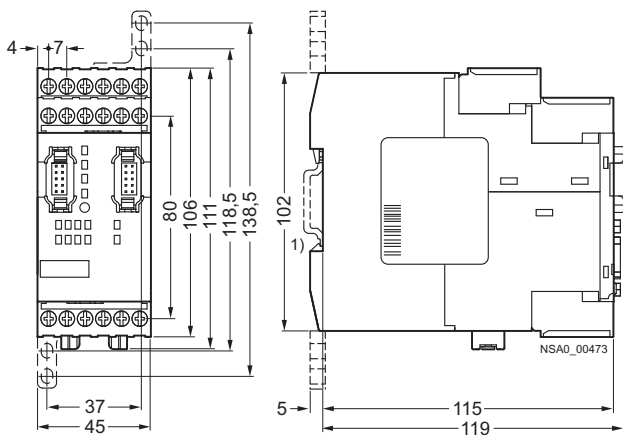

Central module with spring-type terminals

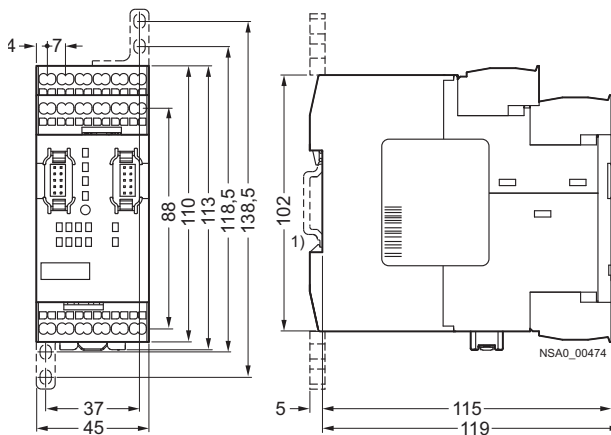

Expansion module with screw terminals

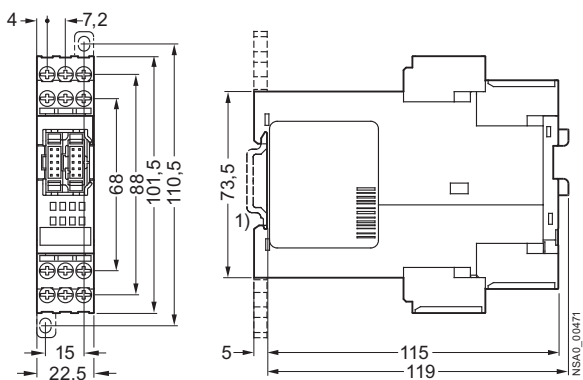

Expansion module with spring-type terminals

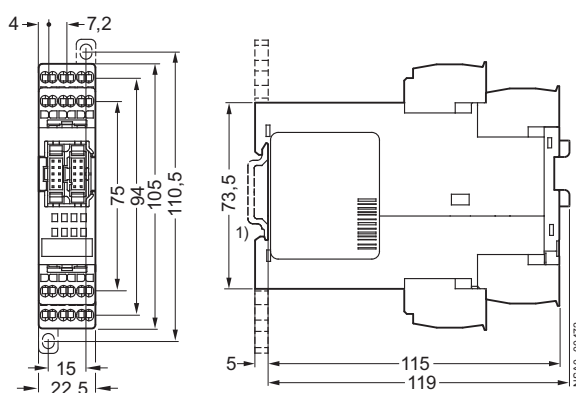

Interface module with screw terminals

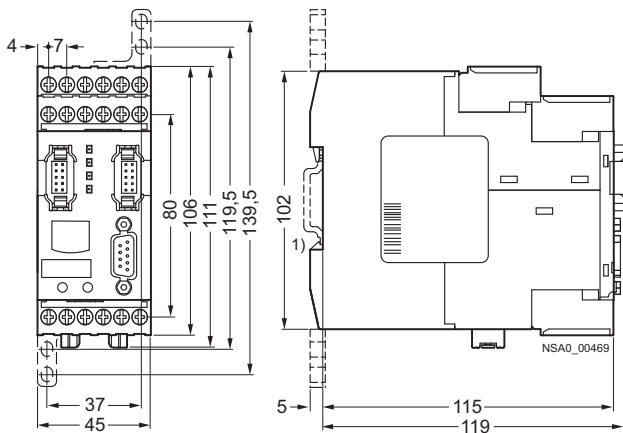

Interface module with spring-type terminals

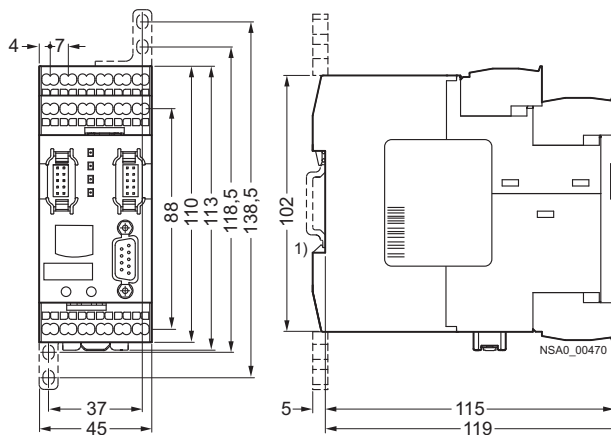

1) For standard mounting rail TH 35 according to EN 60715.

7

Overview

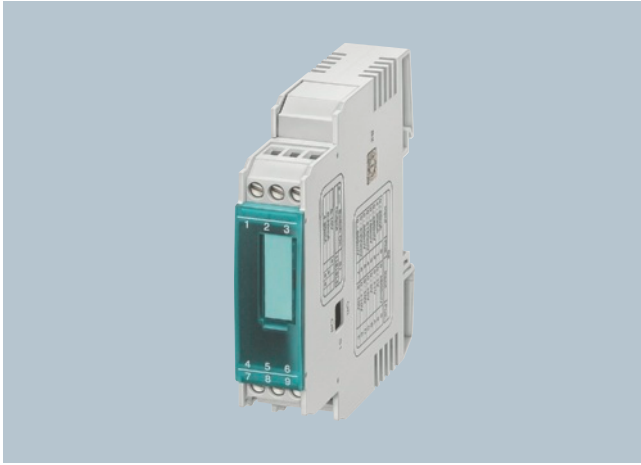

Interface converters perform the coupling function for analog signals on both the input side and the output side. They are in-

dispensable when processing analog values with electronic controls. Under harsh industrial conditions in particular, it is often necessary to transmit analog signals over long distances. This means that electrical separation is essential due to the different supply systems. The resistance of the wiring causes voltage differences and losses which must be prevented.

Electromagnetic faults and overvoltages can affect the signals on the input side in particular or even destroy the analog modules. All terminals of the 3RS17 interface converters are safe up to a voltage of 30 V DC and protected against interchanging poles. Short-circuit protection is an especially important function for the outputs.

The devices are EMC-tested according to

- EN 61000-6-2 (Electromagnetic compatibility (EMC) - Generic standards - Immunity for industrial environments)
- EN 61000-6-4 (Electromagnetic compatibility (EMC) - Generic standards - Emission standard for industrial environments)

The analog signals comply with

- IEC 60381-1, -2 (Analogue signals for process control systems)

Function

Active interface converters

Active interface converters provide maximum flexibility for the application by the use of an external supply voltage. Configuration with active interface converters is extremely easy because input and output resistances and voltage drops are compensated by the auxiliary supply. They support electrical separation as well as conversion from one signal type to another or reinforcement. The load of the measured value transmitter is negligible.

Passive interface converters

Passive interface converters do not require an external supply voltage. This advantage can only be used by current signals that are converted 1:1. Reinforcement or conversion is not possible. The converters are used for complete electrical separation of current signals and to protect the inputs and outputs. Passive isolators do not operate reaction-free, any load on the output produces an equal load on the input. When the passive converter is to be used, the output performance of the sensor and the input resistance of the analog input must be analyzed. This technique is being increasingly implemented in the case of pure current signals.

Calculation guide for passive converters

Important: Please note the following when using passive separators:

The current-driving voltage of the measuring transducer U_E must be sufficient to drive the maximum current of 20 mA over the passive separator with a voltage loss of $U_V = 2.8$ V and the load R_B .

This means that:

$$U_B \geq U_E = 2.8 \text{ V} + 20 \text{ mA} \times R_B$$

Distribution of the voltages in the case of passive separators

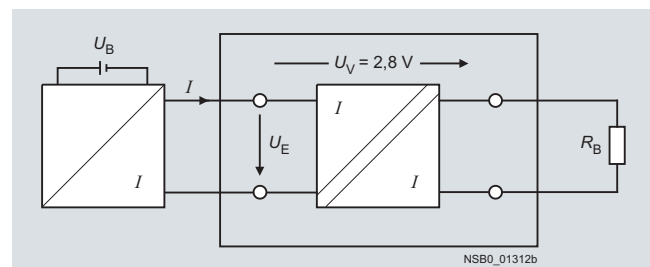

Input voltage depending on the load at $I_a = 20$ mA

The following graphic shows the input voltage U_E as a function of the load R_B taking into account the voltage loss U_V . If the load is known, the y-axis shows the minimum voltage that has to be supplied by the current source in order to drive the maximum current of 20 mA over the passive isolator and load.

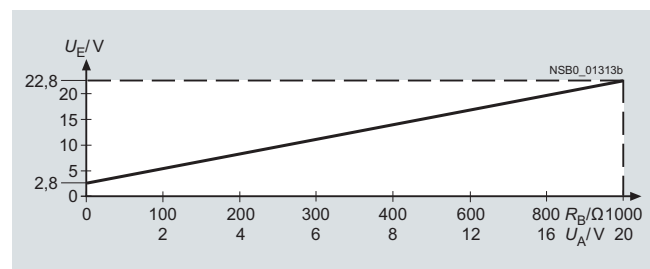

Interface Converters

3RS17 interface converters

Current carrying capacity of the outputs

A maximum output load is specified for current signals. This resistance value specifies how large the input resistance of the next device connected in series can be as a result of the power of the converter.

For voltage signals, the maximum current that can be drawn from the output is the decisive factor.

2-way separation

In the case of 2-way separation, the input is electrically separated from the output. The "zero potential" of the supply voltage is the same as the reference potential for the analog output signal.

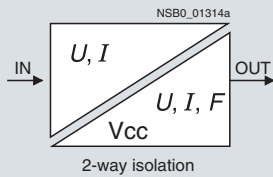

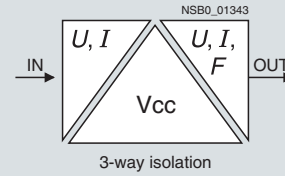

3-way separation

For the 3-way separation, each circuit is electrically separated from the other circuits, i. e. input, output, and supply voltage do not have a potential link.



Technical specifications

Type 3RS17		24 V AC/DC		24 ... 240 V AC/DC	
General data					
Supply voltage operating range	DC		0.7 ... 1.25x U_n		0.7 ... 1.1 x U_n
	AC		0.8 ... 1.2 x U_n		0.8 ... 1.1 x U_n
Rated power		W	Typically 0.3		Typically 0.75
Electrical separation of input/output			Active disc.: 1500 V, 50 Hz, 1 min; Passive disc.: 500 V, 50 Hz, 1 min		4000 V, 50 Hz, 1 min
Rated insulation voltage U_i		V	50		300
Degree of pollution 2 Overvoltage category III acc. to EN 60664-1					
Ambient temperature	During operation	°C	-25 ... +60		
	During storage	°C	-40 ... +85		
Connection type			 Screw terminals		
<ul style="list-style-type: none"> Terminal screw Solid Finely stranded with end sleeve AWG cables, solid or stranded Tightening torque 			M3 (for standard screw driver size 2 and Pozidriv 2)		
		mm ²	1 x (0.5 ... 4)/2 x (0.5 ... 2.5)		
		mm ²	1 x (0.5 ... 2.5)/2 x (0.5 ... 1.5)		
		AWG	2 x (20 ... 14)		
		Nm	0.8 ... 1.2		
Connection type			 Spring-type terminals		
<ul style="list-style-type: none"> Solid Finely stranded, with end sleeves acc. to DIN 46228 Finely stranded AWG cables, solid or stranded 	Enclosures EN 60529	mm ²	2 x (0.25 ... 1.5)		
	Terminals EN 60529	mm ²	2 x (0.25 ... 1.5)		
		mm ²	2 x (0.25 ... 1.5)		
		AWG	2 x (24 ... 16)		
Vibration resistance acc. to IEC 60068-2-6			10 ... 55 Hz: 0.35 mm		
Shock resistance acc. to IEC 60068-2-27		g/ms	15/11		
Input					
Impedance	Voltage inputs	kΩ	330		
	Current inputs, active	Ω	100		
Input voltage max.	Voltage inputs	V	30 AC/DC		
	Current inputs, active	V	30 AC/DC		
Operating current	Current inputs, passive	μA	100/250 (6.2 mm width)		
Voltage drop	Current inputs, passive	V	2.7 at 20 mA		
Output					
Internal resistance	Voltage output, 0 ... 10 V AC/DC	Ω	55		
Output load	Current 0/4 ... 20 mA active, max.	Ω	400		
	Current 0 ... 20 mA passive, max.	Ω	1000 at 20 mA		
	Frequency, min.	Ω	2400		
Output voltage	Frequency	V	20.9		
Output current	Voltage output, 0 ... 10 V, max.	mA	21; note the terminating resistance (> 500 Ω)!		
	Frequency, max.	mA	10		
Short-circuit current	Voltage output, 0 ... 10 V AC/DC	mA	40		
	Current output, 0 ... 20 mA, passive	mA	Corresponds to the input current		
	Frequency	mA	15		
Protection of the outputs			Short-circuit resistant		
Max. overvoltage at output		V	30		
Accuracy					
Total error at 23 °C	Active disconnecter (frequency)	%	0.1		
	Active disconnecter (U, I)	%	0.1 ¹⁾		
Linearity error	Active disconnecter (U, I)	%	0.02		
	Active disconnecter (frequency)	%	0.02		
Deviation due to ambient temperature	Active disconnecter (frequency)		0 ... 50 Hz: 7.5 mHz/K; 0 ... 100 Hz: 15 mHz/K;		
	Active disconnecter (U, I)		0 ... 1 kHz: 0.15 Hz/K; 0 ... 10 kHz: 1.5 Hz/K		
	Passive disconnecter		0 ... 10 V: 1.5 mV/K; 0/4 ... 20 mA: 3 μA/K With load < 600 Ω: <100 ppm/K of measured value With load ≥ 600 Ω: < 175 ppm/K of measured value		
Transmission error	Passive disconnecter	%	0.1		
Measured value load error		%/Ω	0.06/100		
Limit frequency at 3 dB	Active disconnecter (frequency)	Hz	30		
	Active disconnecter (U, I)	Hz	30		
	Passive disconnecter	Hz	50		
Rise time (10 ... 90 %)	Active disconnecter (frequency)		10 + 1 period		
	Active disconnecter (U, I)	ms	10		
Settling time at 1 % accuracy	Active disconnecter (frequency)		30 + 1 period		
	Active disconnecter (U, I)	ms	30		
Residual ripple	Active disconnecter (U, I)	mV _{eff}	< 5		
	Passive disconnecter	mV _{eff}	< 8		

The accuracy refers to the upper limit of effective range if not otherwise stated.

¹⁾ For 3RS17 06: 0.1 % for selected output 4... 20 mA;
0.3 % for selected output 0 ... 20 mA;
0.3 % for selected output 0 ... 10 V and from an input voltage > 50 mV.

For an input voltage < 50 mV an offset of max. 20 ms is effective at the output.

Interface Converters

3RS17 interface converters

Dimensional drawings

6.2 mm design

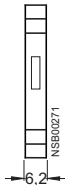

12.5 mm design

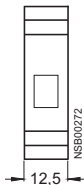

17.5 mm design

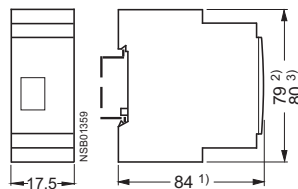

- 1) Depth for 3RS17 25 is approx. 90 mm.
- 2) Dimensions for screw terminal.
- 3) Dimensions for spring-type terminal.

Schematics

3RS17 00-..D..
 3RS17 02-..D..
 3RS17 03-..D..
 3RS17 05-..D..

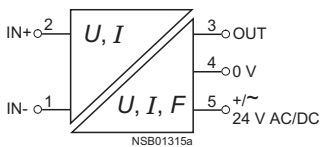

3RS17 06- . FD00

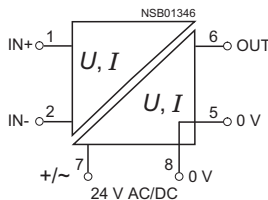

3RS17 06-.FE00

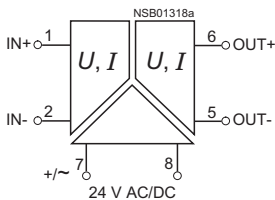

3RS17 0-..W00

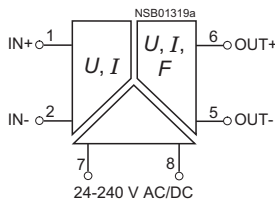

3RS17 25-.FD00

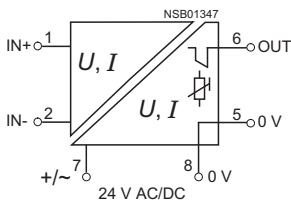

3RS17 25-.FW00

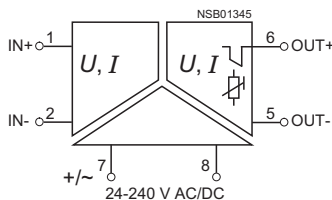

3RS17 20-.ET00

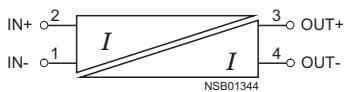

3RS17 21-.ET00

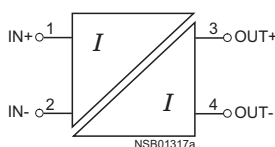

3RS17 22-.ET00

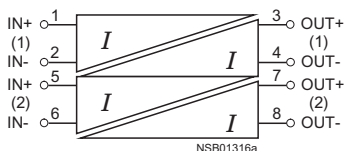

Detecting Devices



8/2	Introduction
	3SE5, 3SE2, 3SE3 Position Switches
8/4	General data
8/11	3SE5, plastic and metal enclosures
8/20	3SE2, plastic enclosures
8/26	3SE2, metal enclosures
8/36	3SE3, metal enclosures, compact design with molded cable <u>Open-Type</u>
8/38	3SE5, open-type design
8/39	3SE3, open-type design <u>With Separate Actuator</u>
8/40	General data
8/43	3SE5, plastic and metal enclosures
8/46	3SE2, plastic enclosures <u>With Solenoid Interlocking</u>
8/47	General data
8/49	3SE5, plastic and metal enclosures
8/51	3SE2, metal enclosures <u>Hinge Switches</u>
8/52	General data
8/53	3SE5, plastic and metal enclosures
8/54	3SE2, plastic enclosures <u>For Explosion Protection (ATEX)</u>
8/55	3SE5, metal enclosures
	3SF1 AS-Interface Position Switches
8/56	General data
8/58	Plastic and metal enclosures <u>With Separate Actuator</u>
8/59	General data
8/60	Plastic and metal enclosures <u>With Solenoid Interlocking</u>
8/61	General data
8/62	Plastic and metal enclosures
	3SE6 Magnetically Operated Switches
8/63	Magnetic monitoring systems

Detecting Devices

Introduction

Overview



	Position switches, standard				Hinge switches		Open-type
Enclosures							
Plastic	✓	✓	--	--	✓	--	✓
Metal	--	--	✓	✓	--	✓	--
Dimensions (W x H x D) in mm	31 x 68 x 33	50 x 53 x 33	40 x 78 x 38	56 x 78 x 38	31 x 68 x 33	40 x 78 x 38	30 x 48.5 x 20
Degree of protection	IP65	IP66/IP67	IP66/IP67	IP66/IP67	IP65	IP66/IP67	IP10 or IP20
Standards							
IEC 60947-5-1	Mounting and operating points acc. to EN 50047	Operating points acc. to EN 50047	Mounting and operating points acc. to EN 50041	Operating points acc. to EN 50041	Mounting and operating points acc. to EN 50047	Mounting and operating points acc. to EN 50041	Mounting and operating points acc. to EN 50047
Approvals	CE, UL, CSA, CCC		CE, UL, CSA, CCC		CE, UL, CSA, CCC		
Contact blocks							
2 slow-action contacts	1 NO + 1 NC		1 NO + 1 NC		--		1 NO + 1 NC
2 snap-action contacts	1 NO + 1 NC		1 NO + 1 NC		1 NO + 1 NC		1 NO + 1 NC
2 snap-action contacts, short stroke	1 NO + 1 NC		✓		✓		✓
2 snap-action contacts with 2 x 2 mm contact gap	1 NO + 1 NC		✓		✓		✓
3 slow-action contacts	1 NO + 2 NC		1 NO + 2 NC		✓		1 NO + 2 NC
3 snap-action contacts	1 NO + 2 NC		1 NO + 2 NC		1 NO + 2 NC		1 NO + 2 NC
Special features							
LED status display	✓		✓		✓		--
Increased corrosion protection	✓		✓		✓		--
Explosion protection (ATEX)	--		✓		--	✓	--
ASIsafe integrated	✓		✓		✓		--
Electrical specifications							
Insulation voltage U_i	400 V		400 V		400 V		400 V
Conventional thermal current I_{the}	6 A/10 A (3-/2-pole)		6 A/10 A (3-/2-pole)		6 A/10 A (3-/2-pole)		6 A
Terminals							
Cable entry	1 x M20 x 1.5	2 x M20 x 1.5	1 x M20 x 1.5	3 x M20 x 1.5	1 x M20 x 1.5	1 x M20 x 1.5	--
M12 connector socket 4-, 5- or 8-pole	✓	✓	✓	✓	✓	✓	--
Connector socket, 6-pole + PE	--	--	✓	✓	--	--	--
Actuators							
Rounded plungers and roller plungers	✓		✓		--		✓
Roller and angular roller levers	✓		✓		--		--
Spring rod	✓		✓		--		--
Twist levers and rod actuators	✓		✓		--		--
Fork lever	--		✓		--		--
Hinges for mounting	--		--		✓		--
Page							
Standard	8/11	8/11	8/14	8/14	8/17	8/17	8/38
ASIsafe	8/58	8/58	8/58	8/58	8/58	8/58	--
ATEX	--	--	8/55	8/55	--	8/55	--

✓ Available

-- Not available



3SE5 232,
3SE5 242,
3SF1 2.4



3SE5 112,
3SE5 122,
3SF1 1.4



3SE5 322,
3SE5 312,
3SF1 3.4



3SE6

	Position switches with separate actuator		Position switches with solenoid interlocking	Magnetically operated switches
Enclosures				
Plastic	✓	--	✓	✓
Metal	--	✓	✓	--
Dimensions (W x H x D) in mm	31 x 68 x 33, 50 x 53 x 33	40 x 78 x 38, 56 x 78 x 38	54 x 185 x 44	M30 x 44, 19 x 33 x 13, 25 x 88 x 13
Degree of protection	IP65, IP66/IP67	IP66/IP67	IP66/IP67	IP67
Standards				
IEC 60947-5-1	Mounting acc. to EN 50047	Mounting acc. to EN 50041	EN 1088, GS-ET 19	Category 3 or 4 acc. to EN ISO 13849-1 (EN 954-1)
Approvals	CE, TÜV, UL, CSA, CCC		CE, TÜV, UL, CSA, CCC	CE, UL, CSA
Contact blocks				
2 slow-action contacts	1 NO + 1 NC	--	--	--
2 snap-action contacts	--	--	--	--
3 slow-action contacts	1 NO + 2 NC	--	--	--
3 snap-action contacts	--	--	--	--
6 slow-action contacts	--	--	2 x (1 NO + 2 NC)	--
Reed contacts	--	--	--	1 NO + 1 NC, 2 NC
Special features				
LED status display	✓	--	✓	--
Increased corrosion protection	✓	--	✓	--
Explosion protection (ATEX)	✓	--	--	--
ASIsafe integrated	✓	--	✓	--
Electrical specifications				
Insulation voltage U_i	400 V	--	400 V	--
Conventional thermal current I_{the}	6 A	--	6 A	--
Terminals				
Cable entry	1 x M20 x 1.5, 2 x M20 x 1.5	1 x M20 x 1.5, 3 x M20 x 1.5	3 x M20 x 1.5	--
M12 connector socket, 4- or 5-pole	✓	✓	✓	✓
Molded cables	--	--	--	✓
AS-Interface	✓	✓	✓	✓ (through I/O module)
Actuators				
Separate actuators	✓	--	✓	--
Page				
Standard	8/43	8/43	8/49	8/63
ASIsafe	8/60	8/60	8/62	8/63
ATEX	--	8/55	--	--

✓ Available

-- Not available

3SE5, 3SE2, 3SE3 Position Switches

General data 3SE5

Overview

Position switches in the innovative SIRIUS 3SE5 series are modern in design, compact, modular and simple to connect.

Complete units

Popular versions of the position switches in standard enclosures are available as complete units.



Position switches with plastic and metal enclosures

Modular system

The 3SE5 series features a new modular system comprising different sizes of the basic switch and an actuator which must be ordered separately. Thanks to the modular design of the switch the user can select the right solution for his application from numerous versions and install it himself in a very short time. The short delivery times of the modules enable fast replacement and thus ensure high plant availability.



Examples of selection options in the modular system

3SE2 series

The position switches of the 3SE2 series are still available, in particular those switch versions which are not yet covered by the new 3SE5 series, including the complete 3SE2 230 series with 40 mm plastic enclosure or additional switching element versions, e. g. with make-before-break, with 2 NO contacts and with 3 or 4 contacts.

Design

Enclosure sizes

The 3SE5 switches are available in five different enclosure sizes:

- Open-type position switch IP20 or IP10
- Plastic enclosures according to EN 50047 (31 mm wide), 1 cable entry
- Plastic enclosures (50 mm wide), 2 cable entries
- Metal enclosures according to EN 50041 (40 mm wide), 1 cable entry
- Metal enclosures (56 mm wide), 3 cable entries

The following items are available in addition from the 3SE2 series:

- Plastic enclosure according to EN 50041, 40 mm wide
- Metal enclosures with 3 or 4 contacts, 56 mm wide

Enclosure versions

Various basic switches can be selected for the enclosures:

- With switching elements with two or three contacts (screw terminals) designed as slow-action or snap-action contacts
- Optional LED status display
- With mounted four or five-pole M12 connector socket (available for the wide enclosures as an accessory for self-assembly)
- With 6-pole connector socket + PE on the metal enclosures
- With increased corrosion protection
- Metal enclosures for explosion protection (ATEX) ([see page 8/55](#))
- AS-Interface version with integrated ASIsafe electronics for all enclosure designs ([see page 8/56](#))

Actuator variants

The following actuator variants are available:

- Rounded plungers
- Roller plungers
- Roller lever
- Angular roller lever
- Spring rod
- Twist levers and rod actuators
- Fork lever

The actuator rollers are available with various materials and diameters.

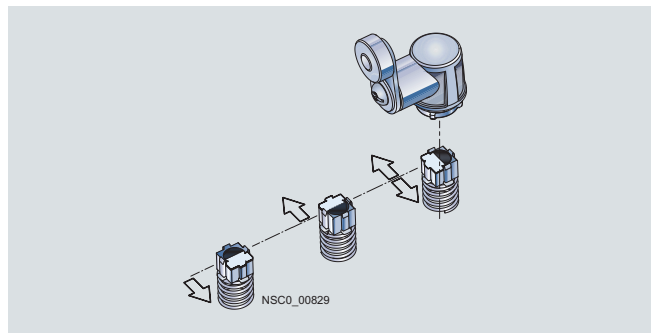

Twist actuators for twist levers and rod actuators, with setting of switching to right, left or right/left (standard for all twist actuators except fork levers)

Optional LED indicators

LED indicators available for all enclosure sizes



The enclosure versions can be supplied with an LED signaling indicator (1 × green + 1 × yellow). This is the first time that optical status monitoring is also available for small standard enclosures according to EN 50047. The LED signaling indicators are available in all common voltages (24 V DC and 230 V AC).

Additional contacts

Exchangeable two and three-pole switching blocks for all enclosure sizes



The new three-pole switching block (2 NC, 1 NO) in snap-action and slow-action is regularly available for all enclosure forms. It offers more switching through redundant shutdowns (2 NC contacts) with simultaneous signaling (1 NO contact). The same installation space is required as for a two-pole switching block.

Contact reliability

The new switching blocks ensure an extremely high contact stability. This applies even when the devices are switching low voltages and currents, e. g. 1 mA at 5 V DC.

Positive opening ➔

The NC contacts of the switch are forced open mechanically, positively-driven and reliably by the plunger. This is referred to as "positive opening".

Mounting

Easy plug-in method – for fast replacement of the actuator head



- (1) Open cover
- (2) Actuate locking lever
- (3) Replace the head (turnable by 16 × 22.5°)
- (4) Lock and close the cover

Fast connection method

For plastic enclosure with a width of 31 mm

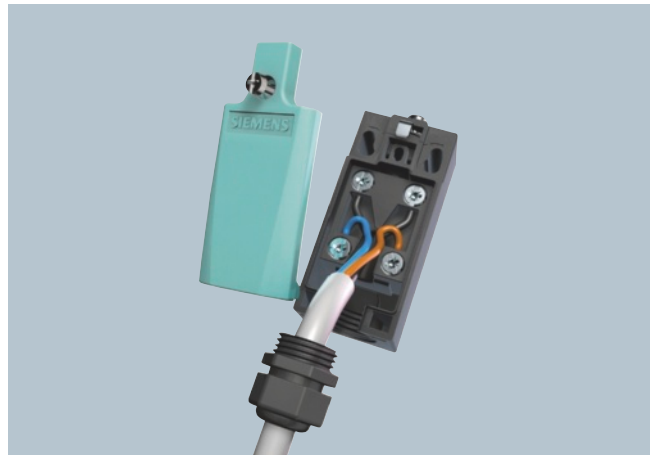

These position switches can be wired quickly and easily as an added customer benefit. The connecting cable is first connected to the terminals of the contact block and then guided through a slit into the cable gland opening. The time saved through this new connection method is approx. 20 to 25 %.

Online configurator

The online configurator helps you not only to select and order the right switch but also to create complete product documentation.

- Product data sheets
- Dimensional drawings
- Operating travel diagrams
- CAD data in 2D and 3D model images
- Ordering data
- Product photos

<http://www.siemens.com/lowvoltage/configurators>

3SE5, 3SE2, 3SE3 Position Switches

General data 3SE2, 3SE3

Overview



With the SIRIUS standard position switches, mechanical positions of moved machine parts are converted into electrical signals. Through their modular and uniform design and large number of variants, the devices can meet practically all requirements in industry.

Scope of supply

The 3SE2 position switches are supplied as standard as complete units. Available in addition are basic switches without an operating mechanism which are used preferably for types of operating mechanisms not found in the standard range.

Switch versions which have been replaced by the new 3SE5 devices are no longer in the standard range.

Design

Enclosure sizes

The 3SE2 switches are available in different enclosure sizes:

- Plastic enclosures according to EN 50047 (31 mm wide), 1 cable entry
- Plastic enclosures according to EN 50041 (40 mm wide), 1 cable entry
- Plastic enclosures (50 mm wide), 2 cable entries
- Metal enclosures according to EN 50041 (40 mm wide), 1 cable entry
- Metal enclosures (56 mm wide), 3 cable entries

The following items are available in addition in the 3SE3 series:

- IP20 open-type position switches
- Compact position switches with metal enclosure and molded cable

Enclosure versions

Various basic switches can be selected for the 3SE2 series:

- Standard enclosures (plastic or metal) with two slow-action or snap-action contacts (screw terminals)
- Metal enclosures with three slow-action contacts
- Metal enclosures with four slow-action or snap-action contacts

Actuator variants

The following actuator variants are available:

- Rounded plungers
- Roller plungers
- Roller lever
- Angular roller lever
- Spring rod
- Twist levers and rod actuators
- Fork lever

Design

Enclosure

The 3SE2 position switches are in either a narrow or wide enclosure made of fiber-glass strengthened, flame-retardant plastic or cast aluminum.

The position switches in a narrow enclosure comply with the standards in terms of their enclosure and actuator as well as their fixing dimensions and operating points:

- EN 50047 for rounded plunger, roller plunger, roller lever and twist lever actuators
 - 3SE2 200 series with plastic enclosure
- EN 50041 for rounded plunger, roller plunger, twist lever and rod actuators
 - 3SE2 230 series with plastic enclosure
 - 3SE2 120 series with metal enclosure

The narrow enclosures have one and the wide enclosures have two or three cable entries, suitable for looping through cables. The cable entry has a metric thread M20 × 1.5 for cable glands with 6 mm long threads (see [Accessories](#)).

To secure position switches with a safety function against changes in their position, keyed techniques must be employed on installation, such as:

- Fixing by means of round holes
- For longitudinal holes, guide pins and stops must also be used.

Actuators

All actuators can be retro-fitted or exchanged for another version. They can also be repositioned every 90° so that the switches can be operated from any of the four sides.

Important: The position switches must not be used as an end stop.

Standard, rounded and roller plungers

- Operation in direction of the plunger axis or in case of roller plunger with bar at right angles to the plunger axis.
- Rounded and roller plungers have an additional overtravel and hence a large operating distance.
- The roller plunger is recommended for lateral actuation and relatively long overtravel.

Roller and angular roller levers

- For a high starting speed of $v_{\max} = 2.5$ m/s
- For actuators made of finely ground steel in the form of cams, straight-edges or cam disks
- Very long mechanical endurance

Spring rod

- Can be used for undefined actuations and changing starting conditions
- Starting from any direction

Twist levers and rod actuators

- For a high starting speed of $v_{\max} = 3$ m/s
- Variety of starting options
- Insensitive to oil, dirt, grinding dust, ice and coarse-grained material
- With the twist lever the maximum approach angle is always equal to the maximum trailing angle.
- The rod actuator must be used when no actuation with approach and trailing angle is possible.

Fork lever

- Switchable in two directions
- For reciprocating movements
- Latched actuator

Rounded plungers with short-stroke contact block

- Exact switching response
- Operating travel and hysteresis greatly reduced
- Optimized wear characteristics
- Suitable for the monitoring of doors and access flaps up to Category 4 according to ISO 13849-1 (EN 954-1)

Rounded and roller plungers with central fixing

- Fast mounting with M18 × 1 thread
- Easy adjustment
- Same mounting type as the proximity switch BERO

Contacts

The position switches with plastic enclosures are available with 2 contacts; the position switches with metal enclosures are available with 2, 3 or 4 contacts. The contacts can be snap-action contacts, slow-action contacts or slow-action make-before-break contacts. The contacts are designed for a thermal current of 10 A.

Contact reliability

The movable contacts are double-break contacts. This ensures an extremely high contact stability, even when the devices are switching low voltages and currents, e. g. 5 V DC/1 mA.

As the moving double-break contacts are electrically isolated from each other, the position switches can also switch, without any reservations, circuits up to 380 V with different potentials.

The operating point of the snap-action contacts is independent of the contact erosion.

The contact chamber is covered to prevent ingress of foreign bodies.

Connection

- Metric thread M20 × 1.5 for mounting glands, connector sockets or adapters
- Expansion range with mounted connector socket
- With AS-Interface F adapter for direct connection to ASIsafe; usable up to Category 2 according to ISO 13849-1 (EN 954-1).
- With AS-Interface F adapter for direct connection to ASIsafe; with additional M12 connector socket for connection of the second position switch, usable up to Category 4 according to ISO 13849-1 (EN 954-1).

Function

Positive opening



The NC contacts of the switch are forced open mechanically, positively-driven and reliably by the plunger. This is referred to as "positive opening".

In order to ensure this positive opening, the position switches must be actuated in such a way that the nominal values for the positive opening are substantially exceeded.

3SE5, 3SE2, 3SE3 Position Switches

General data

Technical specifications

Type	3SE5 1..., 3SE5 2..	
General data		
Standards	IEC 60947-5-1, EN 60947-5-1	
Rated insulation voltage U_i	V	400
Degree of pollution acc. to EN 60664-1	Class 3	
Rated impulse withstand voltage U_{imp}	kV	6
Rated operational voltage U_e	V	400 AC; over 300 V AC only for equal potential
Conventional thermal current I_{th}	A	10 6
Rated operational current I_e		2 contacts 3 contacts
• With alternating current 50 / 60 Hz		I_e / AC-15 I_e / AC-15
- At 24 V	A	6 6
- At 120 V	A	6 3
- At 240 V	A	3 1.5
• For direct current		I_e / DC-13 I_e / DC-13
- At 24 V	A	3 3
- At 125 V	A	0.55 0.55
- At 250 V	A	0.27 0.27
Short-circuit protection¹⁾		
• With DIAZED fuse links, operational class gG	A	6
• With miniature circuit breaker, Char. C	A	1
Mechanical endurance		
• Basic switches		15 × 10 ⁶ operating cycles
• With spring rod, 3SE5 ...-R..		10 × 10 ⁶ operating cycles
• With fork lever 3SE5 1...-T..		1 × 10 ⁶ operating cycles
Electrical endurance		
• With 3RH11, 3RT10 16 to 3RT10 26 contactors		10 × 10 ⁶ operating cycles
• For AC-15 utilization category		0.1 × 10 ⁶ operating cycles when interrupting I_e / AC-15 = 3 or 1.5 A at 240 V
• For DC-13 utilization category		With DC current the endurance of the switching element depends not only on the breaking current but also on the voltage, the circuit inductance and the speed of switching. No generally valid information can be given.
Switching frequency With 3RH11, 3RT10 16 to 3RT10 26 contactors		6000 operating cycles/h
Switching accuracy For repeated switching, measured at the plunger of the contact block	mm	0.05
Operating point with snap-action contacts		Independent of contact erosion, constant throughout the endurance of the switch
Rated data acc. to ,  and 		
• Rated voltage	V	300
• Uninterrupted current	A	6
• Switching capacity		Heavy duty, A 300/B 300/Q 300

Type	3SE5 23.	3SE5 24.	3SE5 11.	3SE5 12.	3SE5 25.
Enclosures					
Enclosures					
• Material	Ultramid A3X2G7		Zinc diecasting GD Zn Al4 Cu1		--
• Width	mm	31 50	40 56		30
• Dimensions acc. to EN	EN 50047		EN 50041	--	--
Degree of protection acc. to EN 60529	IP65		IP66/IP67 ²⁾		2 contacts: IP20, 3 contacts: IP10
Ambient temperature					
• During operation	°C	-25 ... +85			-25 ... +85
• In operation, switch with LEDs	°C	-25 ... +70			--
• Storage, transport	°C	-40 ... +90			-40 ... +90
Mounting position	Any				
Connection					
Cable entry	1 × (M20 × 1.5)	2 × (M20 × 1.5)	1 × (M20 × 1.5)	3 × (M20 × 1.5)	--
Conductor cross-sections³⁾					
• Solid	mm ²	2 × (0.5 ... 1.5)			
• Finely stranded with end sleeve	mm ²	2 × (0.5 ... 1.5)			
Tightening torque , contact block	Nm	0.8 ... 1.0			
Protective conductor connection inside enclosure	--			M3.5	--

1) Without any welds according to EN 60947-5-1.

2) For twist actuators with spring rod and rod actuators: IP65/IP67.

3) For the maximum number of connectable conductors for the respective contact block see operating instructions. Download from: <http://www.siemens.com/automation/service&support>

Type	3SE2 1, 3SE2 2, 3SE2 3, 3SE2 4, 3SE3 0			Exception: 3SE2 230-8..00	
General data					
Standards	IEC 60947-5-1, EN 60947-5-1				
Rated insulation voltage U_i	V	500			
Degree of pollution acc. to EN 60664-1	Class 3				
Rated operational voltage U_e	V	500 AC; over 380 V AC only for equal potential		500 AC; over 300 V AC only for equal potential	
Conventional thermal current I_{th}	A	10			
Rated operational current I_e					
• With alternating current 50 / 60 Hz		I_e / AC-12	I_e / AC-15		
- At 24 V	A	10	10		
- At 125 V	A	10	10		
- At 230 V	A	10	6		
- At 400 V	A	10	4		
- At 500 V	A	10	3		
• For direct current		I_e / DC-12	I_e / DC-13	I_e / DC-12	I_e / DC-13
- At 24 V	A	10	10	10	10
- At 48 V	A	6	4	6	4
- At 110 V	A	4	1	4	1
- At 220 V	A	1	0.4	1	0.27
- At 440 V	A	0.5	0.2	0.5	0.1
Short-circuit protection¹⁾ , DIAZED fuse links					
• Operational class gG	A	6		6	
• Characteristic quick	A	10		--	
Mechanical endurance	30 × 10 ⁶ operating cycles			15 × 10 ⁶ operating cycles	
Electrical endurance					
• With 3RH11, 3RT10 16 to 3RT10 26 contactors	10 × 10 ⁶ operating cycles				
• For AC-15 utilization category	0.5 × 10 ⁶ operating cycles when interrupting I_e / AC-15 at 230 V				
• For DC-13 utilization category	With DC current the contact endurance depends not only on the breaking current but also on the voltage, the circuit inductance and the speed of switching. No generally valid information can be given.				
Switching frequency With 3RH11, 3RT10 16 to 3RT10 26 contactors	6000 operating cycles/h			1800 operating cycles/h	
Switching accuracy For repeated switching, measured at the plunger of the contact block	mm	0.05			
Operating point with snap-action contacts	Independent of contact erosion, constant throughout the endurance of the switch				
Ⓢ, Ⓜ and Ⓜ rated data					
• Rated voltage	V	600		600	
• Uninterrupted current	A	10		10	
• Switching capacity	Heavy duty, A 600/Q 600			Heavy duty, A 300/Q 600	

Type	3SE2 200	3SE2 230	3SE2 210	3SE2 120	3SE2 100, 3SE2 303, 3SE2 404	3SE3 0
Enclosures						
Enclosures						
• Type acc. to EN	EN 50047	EN 50041	--	EN 50041	--	--
• Width	mm	31	40	50	40	56
• Material	Fiber-glass strengthened thermoplast			Aluminum (GD - AlSi 12)		--
Degree of protection acc. to EN 60529	IP67	IP66	IP67			IP20
Ambient temperature						
• During operation	-30 ... +85 °C					
Mounting position	Any					
Connection						
Cable entry	1 × (M20 × 1.5)		2 × (M20 × 1.5)	1 × (M20 × 1.5)	3 × (M20 × 1.5)	--
Conductor cross-sections						
• Solid	mm ²	2 × 2.5				
• Finely stranded with end sleeve	mm ²	2 × 1.5				
Protective conductor connection Inside enclosure	--			M3.5		--

1) Without any welds according to EN 60947-5-1.

3SE5, 3SE2, 3SE3 Position Switches

General data

Schematics

3SE5 basic switches, enclosure widths 31 mm, 40 mm, 50 mm, 56 mm and open-type design, 30 mm

Slow-action contacts 1 NO + 1 NC
3SE5 ...-B..., -R...

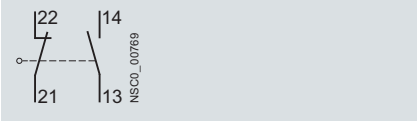

Snap-action contacts 1 NO + 1 NC
3SE5 ...-C..., -F..., -G..., -H..., -N...

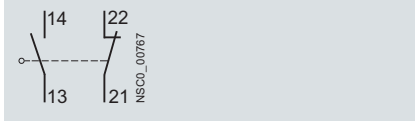

Slow-action contacts 1 NO + 2 NC
3SE5 ...-K..., -Q...

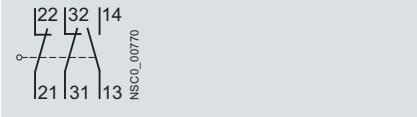

Snap-action contacts 1 NO + 2 NC
3SE5 ...-L...

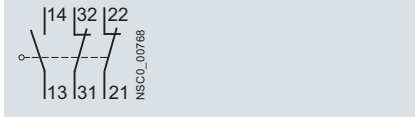

3SE5 connector assignment

M12 connector socket, 4-pole
3SY3 127

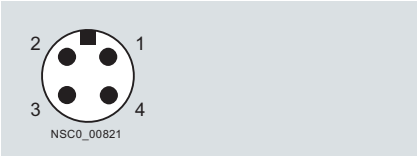

M12 connector socket, 5-pole
3SY3 128

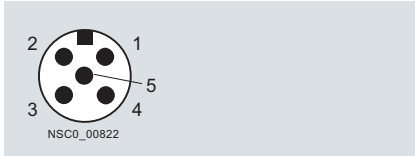

M12 connector socket, 8-pole
3SY3 134

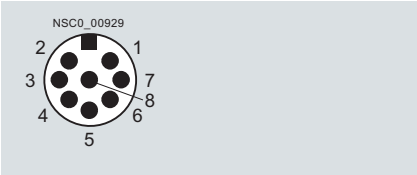

Connector sockets, 6-pole + PE
3SY3 131

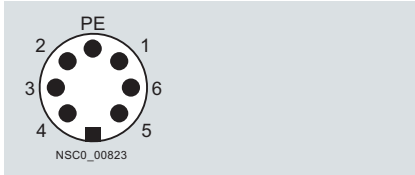

Order No.	Connector sockets		LEDs	Pin assignment								
	Type	Version		Version	Pin 1	Pin 2	Pin 3	Pin 4	Pin 5	Pin 6	Pin 7	Pin 8
M12 connector sockets (4-, 5- or 8-pole)												
3SE5.4-.....-1AC4	3SY3 127	1 NO + 1 NC	--	21	22	13	14	--	--	--	--	--
3SE5.4-.....-1AC5	3SY3 128	1 NO + 1 NC	--	21	22	13	14	PE	--	--	--	--
3SE5.4-.....-1AE0	3SY3 127	2 NC	--	21	22	31	32	--	--	--	--	--
3SE5.4-.....-1AE1	3SY3 128	2 NC	--	21	22	31	32	PE	--	--	--	--
3SE5.4-.....-1AF3	3SY3 128	1 NO + 1 NC	2 LEDs	21	22	13/ LED gn	14/ LED ye	Ground LED	--	--	--	--
3SE5.4-.....-1AD4	3SY3 135	1 NO + 2 NC	2 LEDs	21	22	13/ LED gn	14/ LED ye	31	32	Ground LED	PE	--
Connector sockets, 6-pole + PE												
3SE5.5-.....-1AD0	3SY3 131	1 NO + 1 NC	--	21	22	13	14	--	--	--	--	✓
3SE5.5-.....-1AD1	3SY3 131	1 NO + 2 NC	--	21	22	13	14	31	32	--	--	✓
3SE5.5-.....-1AD2	3SY3 131	1 NO + 2 NC	2 LEDs	21	22	31	32	13/ LED gn	Ground LED	--	--	✓
3SE5.5-.....-1AF2	3SY3 131	1 NO + 1 NC	2 LEDs	21	22	13/ LED gn	14/ LED ye	--	Ground LED	--	--	✓

gn = Green

ye = Yellow

✓ = Connected

Configuration

Actuation and operating travel (angle) for enclosure width 31 mm and 50 mm

Operation by bar (standard) ○ Operating point acc. to EN 50047 (snap-action) * Operating point on return (snap-action) ⊕ Positive opening acc. to EN 60947-5-1 → Direction of operation v_{max} Max. actuating speed 	Slow-action contacts 1 NO + 1 NC Ident. No. 11		1 NO + 2 NC Ident. No. 12		Snap-action contacts 1 NO + 1 NC Ident. No. 11		1 NO + 2 NC Ident. No. 12	
--	---	--	--	--	---	--	--	--

Rounded plungers, type B 3SE5 2...-C05 $v_{max} = 1 \text{ m/s}$ Minimum force required in direction of operation: 18 N	Actuation along plunger axis -BC05 Ident. No. NSCO_00831a $v_{max} 5,5$		Actuation along plunger axis -KC05 Ident. No. NSCO_00835a $v_{max} 5,5$		Actuation along plunger axis -CC05, -HC05 Ident. No. NSCO_00832a $v_{max} 5,5$		Actuation along plunger axis -FC05 Ident. No. NSCO_00835a $v_{max} 5,5$ Short stroke		Actuation along plunger axis -GC05 Ident. No. NSCO_00836a $v_{max} 5,5$ Switching interval $2 \times 2 \text{ mm}$		Actuation along plunger axis -LC05 Ident. No. NSCO_00834a $v_{max} 5,5$	
--	--	--	--	--	---	--	--	--	--	--	--	--

Angular roller levers 3SE5 2...-F1 $v_{max} = 1 \text{ m/s}$ Minimum force required in direction of operation: 9 N	Actuation along plunger axis -BF10 Ident. No. NSCO_00857a 14,8 14,2 13,5 mm 21-22 13-14 ⊕		Actuation along plunger axis -KF10 Ident. No. NSCO_00858a 14,2 13,6 13,0 mm 21-22 31-32 13-14 ⊕		Actuation along plunger axis -HF10 Ident. No. NSCO_00858a 12,5 11,9 11,0 mm 13-14 21-22 ⊕		Actuation along plunger axis -FC05 + head¹⁾ Ident. No. NSCO_00843 13,2 7 2,3 mm 13-14 21-22 ⊕		Actuation along plunger axis -GC05 + head¹⁾ Ident. No. NSCO_00858a 12,5 11,9 11,0 mm 13-14 21-22 ⊕		Actuation along plunger axis -LF10 Ident. No. NSCO_00860a 13,8 13,0 12,2 mm 13-14 31-32 21-22 ⊕	
---	--	--	---	--	--	--	---	--	--	--	---	--

Operation by bar (standard) ○ Operating point acc. to EN 50047 (snap-action) * Operating point on return (snap-action) ⊕ Positive opening acc. to EN 60947-5-1 → Direction of operation v_{max} Max. actuating speed	Slow-action contacts 		Snap-action contacts 	
--	---------------------------------	--	---------------------------------	--

Roller plungers 3SE5 2...-D03, -D04 Form C $v_{max} = 1 \text{ m/s}$ Minimum force required in direction of operation: 18 N	3SE5 2...-D10, -D11 Central fixing Ident. No. NSCO_00892	Lateral actuation 1 NO + 1 NC Ident. No. 11		Lateral actuation 3SE5 2...-BD03 Ident. No. NSCO_00837a mm 3,4 4,0 4,8		Lateral actuation 1 NO + 1 NC Ident. No. 11		Lateral actuation 3SE5 2...-HD03, -HD10 Ident. No. NSCO_00838a mm 2,8 3,6 4,6	
		1 NO + 2 NC Ident. No. 12		Lateral actuation 3SE5 2...-KD03, -KD10 Ident. No. NSCO_00839a mm 4,7 5,5 6		Lateral actuation 1 NO + 1 NC Ident. No. 11		Lateral actuation 3SE5 2...-FC05 + head¹⁾ Ident. No. NSCO_00841 mm 0,9 2,6 4,6 Short stroke	

¹⁾ The basic switch and actuator head/actuator head must be ordered separately.

3SE5, 3SE2, 3SE3 Position Switches

3SE5, plastic and metal enclosures

Operation by bar (standard)

- ⊙ Operating point acc. to EN 50047 (snap-action)
- * Operating point on return (snap-action)
- ⊙ Positive opening acc. to EN 60947-5-1
- Direction of operation
- v_{max} Max. actuating speed

Slow-action contacts

- Contact closed
- Contact open

Snap-action contacts

- Contact closed
- Contact open

Roller levers, type E

3SE5 2...-E1.

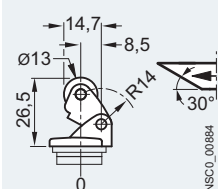

$v_{max} = 1 \text{ m/s}$
Minimum force required in direction of operation: 9 N

1 NO + 1 NC

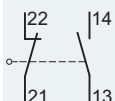

Ident. No. 11

Lateral actuation

3SE5 2...-BE10

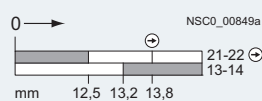

1 NO + 1 NC

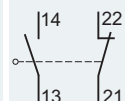

Ident. No. 11

Lateral actuation

3SE5 2...-HE10

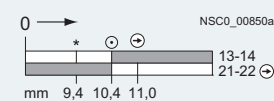

1 NO + 1 NC

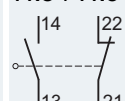

Ident. No. 11

3SE5 2...-FC05 + head²⁾

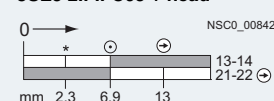

1 NO + 2 NC

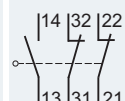

Ident. No. 12

3SE5 2...-LE10

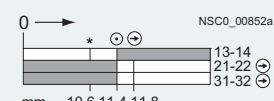

Twist levers¹⁾, type A

3SE5 2...-K2.

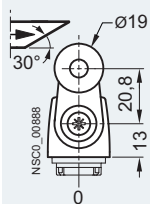

$v_{max} = 1.5 \text{ m/s}$
Minimum torque in direction of operation: 0.25 Nm

1 NO + 1 NC

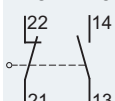

Ident. No. 11

Deflection in direction of rotation

3SE5 2...-BK21

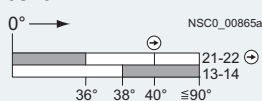

1 NO + 1 NC

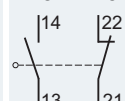

Ident. No. 11

Deflection in direction of rotation

3SE5 2...-HK21

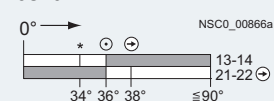

1 NO + 1 NC

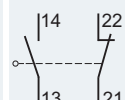

Ident. No. 11

3SE5 2...-FC05 + head²⁾

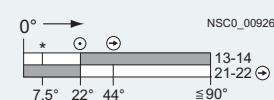

1 NO + 2 NC

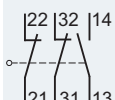

Ident. No. 12

3SE5 2...-KK21

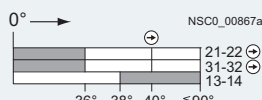

1 NO + 2 NC

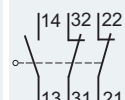

Ident. No. 12

3SE5 2...-LK21

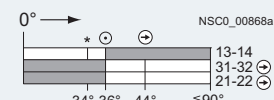

Twist levers¹⁾, adjustable length

3SE5 2...-K6.

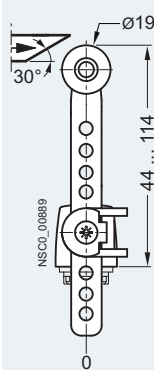

$v_{max} = 1.5 \text{ m/s}$
Minimum torque in direction of operation: 0.25 Nm

1 NO + 1 NC

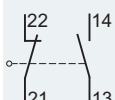

Ident. No. 11

Deflection in direction of rotation

3SE5 2...-BC05 + head²⁾

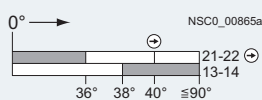

1 NO + 1 NC

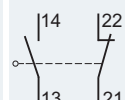

Ident. No. 11

Deflection in direction of rotation

3SE5 2...-HK60

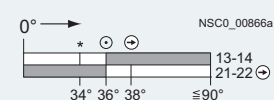

1 NO + 1 NC

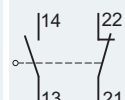

Ident. No. 11

3SE5 2...-FC05 + head²⁾

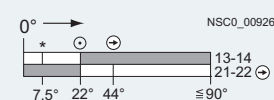

1 NO + 2 NC

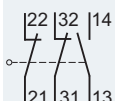

Ident. No. 12

3SE5 2...-KC05 + head²⁾

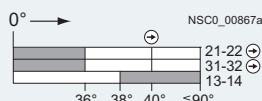

1 NO + 2 NC

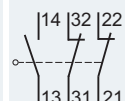

Ident. No. 12

3SE5 2...-LC05 + head²⁾

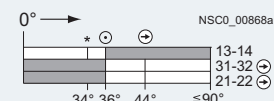

1) Adjustment of the lever in increments of 10°, maximum deflection 90°.

2) The basic switch and actuator head must be ordered separately.

Operation by bar (standard)

- ⊙ Operating point acc. to EN 50041/47 (snap-action)
- * Operating point on return (snap-action)
- ⊙ Positive opening acc. to EN 60947-5-1
- Direction of operation
- v_{max} Max. actuating speed

Slow-action contacts

- Contact closed
- Contact open

Snap-action contacts

- Contact closed
- Contact open

Twist levers¹⁾, adjustable length

3SE5 2...-K5.

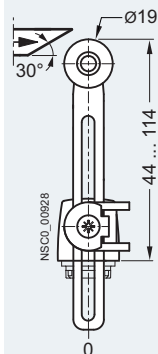

$v_{max} = 1.5$ m/s
Minimum torque in direction of operation: 0.25 Nm

1 NO + 1 NC

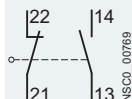

Ident. No. 11

Deflection in direction of rotation

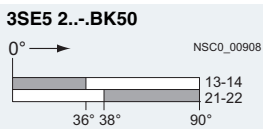

1 NO + 2 NC

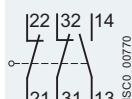

Ident. No. 12

Deflection in direction of rotation

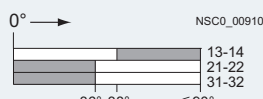

1 NO + 1 NC

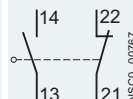

Ident. No. 11

Deflection in direction of rotation

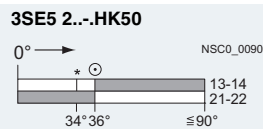

1 NO + 2 NC

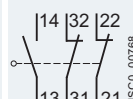

Ident. No. 12

Deflection in direction of rotation

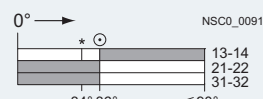

Rod actuators¹⁾, type D

3SE5 2...-K8.

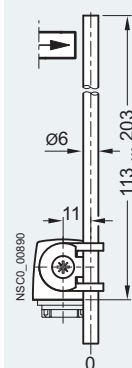

$v_{max} = 1.5$ m/s
Minimum torque in direction of operation: 0.25 Nm

1 NO + 1 NC

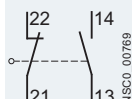

Ident. No. 11

Deflection in direction of rotation

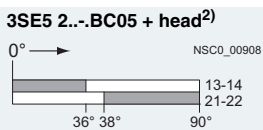

1 NO + 2 NC

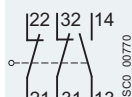

Ident. No. 12

Deflection in direction of rotation

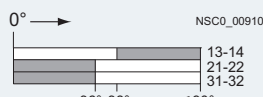

1 NO + 1 NC

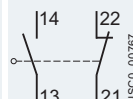

Ident. No. 11

Deflection in direction of rotation

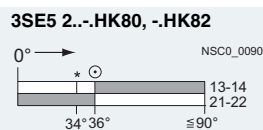

1 NO + 2 NC

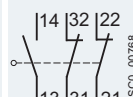

Ident. No. 12

Deflection in direction of rotation

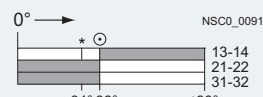

Spring rods

3SE5 2...-R0.

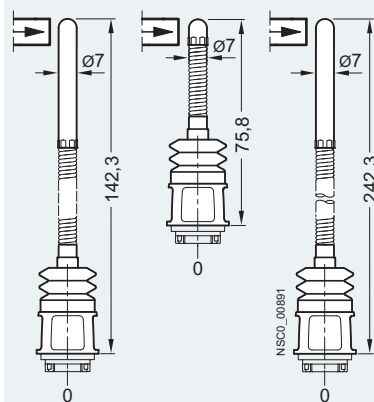

$v_{max} = 1$ m/s
Minimum force required in direction of operation: 9 N

The spring rods can be used only with snap-action contacts.

1 NO + 1 NC

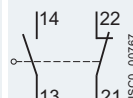

Ident. No. 11

Deflection of spring rod



1 NO + 1 NC

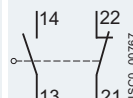

Ident. No. 11

Deflection of spring rod

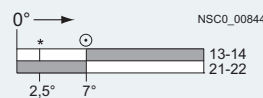

1 NO + 2 NC

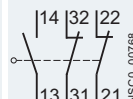

Ident. No. 12

Deflection of spring rod

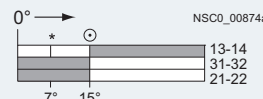

¹⁾ Adjustment of the lever in increments of 10°, maximum deflection 90°.

²⁾ The basic switch and actuator head must be ordered separately.







3SE5, 3SE2, 3SE3 Position Switches

3SE5, plastic and metal enclosures

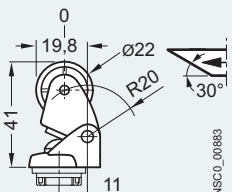
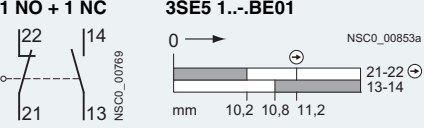
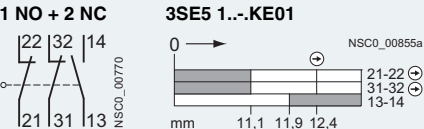
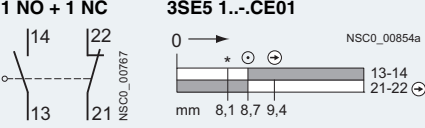
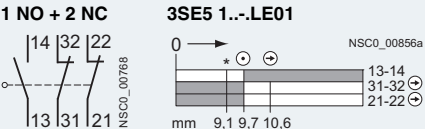
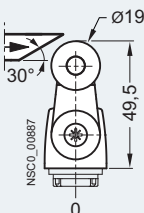
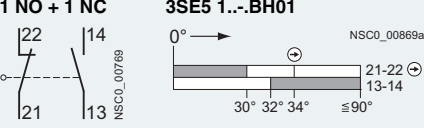
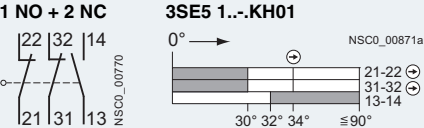
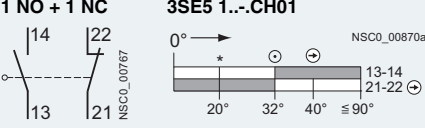
Actuation and operating travel (angle) for enclosure width 40 mm and 56 mm

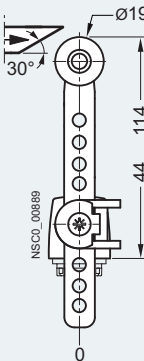
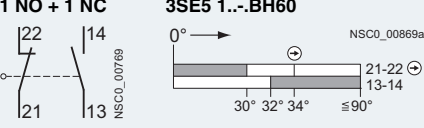
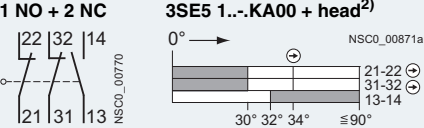
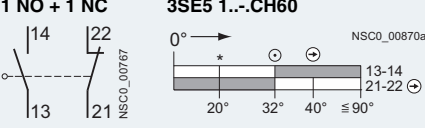
Operation by bar (standard)		Slow-action contacts		Snap-action contacts	
<ul style="list-style-type: none"> Operating point acc. to EN 50041 (snap-action) Operating point on return (snap-action) Positive opening acc. to EN 60947-5-1 Direction of operation v_{max} Max. actuating speed Contact closed Contact open 	<p>1 NO + 1 NC</p> <p>Ident. No. 11</p>	<p>1 NO + 2 NC</p> <p>Ident. No. 12</p>	<p>1 NO + 1 NC</p> <p>Ident. No. 11</p>	<p>1 NO + 2 NC</p> <p>Ident. No. 12</p>	
Rounded plungers, type B		Actuation along plunger axis		Actuation along plunger axis	
<p>3SE5 1...-C02</p> <p>$v_{max} = 1.5 \text{ m/s}$ Minimum force required in direction of operation: 18 N</p>	<p>3SE5 1...-BC02</p>	<p>3SE5 1...-KC02</p>	<p>3SE5 1...-CC02</p>	<p>3SE5 1...-LC02</p>	
Angular roller levers		Actuation along plunger axis		Actuation along plunger axis	
<p>3SE5 112...-F0.</p> <p>$v_{max} = 2.5 \text{ m/s}$ Minimum force required in direction of operation: 9 N</p>	<p>3SE5 1...-BF01</p>	<p>3SE5 1...-KA00 + head¹⁾</p>	<p>3SE5 1...-CF01</p>	<p>3SE5 1...-LF01</p>	
Operation by bar (standard)		Slow-action contacts		Snap-action contacts	
<ul style="list-style-type: none"> Operating point acc. to EN 50041 (snap-action) Operating point on return (snap-action) Positive opening acc. to EN 60947-5-1 Direction of operation v_{max} Max. actuating speed Contact closed Contact open 	<p>Contact closed</p> <p>Contact open</p>	<p>Contact closed</p> <p>Contact open</p>			
Roller plungers, type C		Lateral actuation		Lateral actuation	
<p>3SE5 1...-D02</p> <p>$v_{max} = 1 \text{ m/s}$ Minimum force required in direction of operation: 18 N</p>	<p>1 NO + 1 NC</p> <p>Ident. No. 11</p>	<p>3SE5 1...-BD02</p>	<p>1 NO + 1 NC</p> <p>Ident. No. 11</p>	<p>3SE5 1...-CD02</p>	
	<p>1 NO + 2 NC</p> <p>Ident. No. 12</p>	<p>3SE5 1...-KD02</p>	<p>1 NO + 2 NC</p> <p>Ident. No. 12</p>	<p>3SE5 1...-LD02</p>	

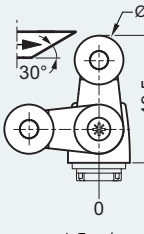
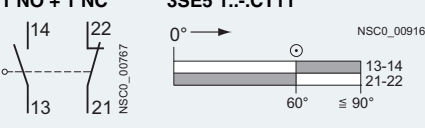
¹⁾ The basic switch and actuator head must be ordered separately.

Operation by bar (standard) ☉ Operating point acc. to EN 50041 (snap-action) * Operating point on return (snap-action) ⊕ Positive opening acc. to EN 60947-5-1 → Direction of operation v_{max} Max. actuating speed	Slow-action contacts ■ Contact closed □ Contact open	Snap-action contacts ■ Contact closed □ Contact open
Roller levers 3SE5 1...-E0.  <p>$v_{max} = 2.5 \text{ m/s}$ Minimum force required in direction of operation: 9 N</p>	Lateral actuation 1 NO + 1 NC  <p>Ident. No. 11</p> 1 NO + 2 NC  <p>Ident. No. 12</p>	Lateral actuation 1 NO + 1 NC  <p>Ident. No. 11</p> 1 NO + 2 NC  <p>Ident. No. 12</p>
Twist levers¹⁾, type A 3SE5 1...-H0.  <p>$v_{max} = 1.5 \text{ m/s}$ Minimum torque in direction of operation: 0.25 Nm</p>	Deflection in direction of rotation 1 NO + 1 NC  <p>Ident. No. 11</p> 1 NO + 2 NC  <p>Ident. No. 12</p>	Deflection in direction of rotation 1 NO + 1 NC  <p>Ident. No. 11</p> 1 NO + 2 NC  <p>Ident. No. 12</p>
Twist levers¹⁾, adjustable length 3SE5 1...-H6.  <p>$v_{max} = 1.5 \text{ m/s}$ Minimum torque in direction of operation: 0.25 Nm</p>	Deflection in direction of rotation 1 NO + 1 NC  <p>Ident. No. 11</p> 1 NO + 2 NC  <p>Ident. No. 12</p>	Deflection in direction of rotation 1 NO + 1 NC  <p>Ident. No. 11</p> 1 NO + 2 NC  <p>Ident. No. 12</p>
Fork levers¹⁾ 3SE5 1...-T1.  <p>$v_{max} = 1.5 \text{ m/s}$ Minimum torque in direction of operation: 0.25 Nm</p>	The fork levers can be used only with snap-action contacts.	Deflection in direction of rotation 1 NO + 1 NC  <p>Ident. No. 11</p> 1 NO + 2 NC  <p>Ident. No. 12</p>

¹⁾ Adjustment of the lever in increments of 10°, maximum deflection 90°.

²⁾ The basic switch and actuator head must be ordered separately.

3SE5, 3SE2, 3SE3 Position Switches

3SE5, plastic and metal enclosures

Operation by bar (standard)

- ⊙ Operating point acc. to EN 50041/47 (snap-action)
- * Operating point on return (snap-action)
- ⊙ Positive opening acc. to EN 60947-5-1
- Direction of operation
- v_{ma} Max. actuating speed

Slow-action contacts

- Contact closed
- Contact open

Snap-action contacts

- Contact closed
- Contact open

Twist levers¹⁾, adjustable length

3SE5 1...-H5.

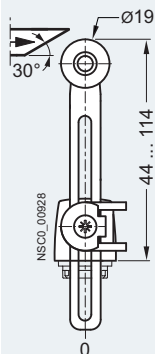

$v_{max} = 1.5 \text{ m/s}$
 Minimum torque
 in direction of operation: 0.25 Nm

1 NO + 1 NC

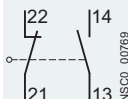

Ident. No. 11

Deflection in direction of rotation

3SE5 1...-BH50

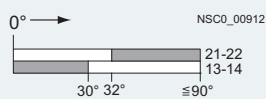

1 NO + 1 NC

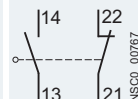

Ident. No. 11

Deflection in direction of rotation

3SE5 1...-CH50, -.CH51

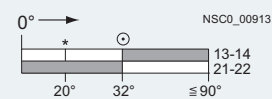

1 NO + 2 NC

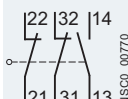

Ident. No. 12

3SE5 1...-KA00 + head²⁾

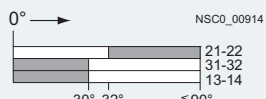

1 NO + 2 NC

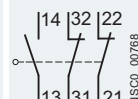

Ident. No. 12

3SE5 1...-LH50

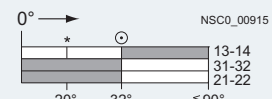

Rod actuators¹⁾, type D

3SE5 1...-H8.

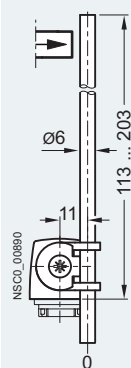

$v_{max} = 1.5 \text{ m/s}$
 Minimum torque
 in direction of operation: 0.25 Nm

1 NO + 1 NC

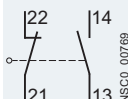

Ident. No. 11

Deflection in direction of rotation

3SE5 1...-BA00 + head²⁾

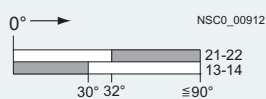

1 NO + 1 NC

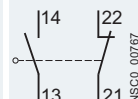

Ident. No. 11

Deflection in direction of rotation

3SE5 1...-CH80, -.CH82

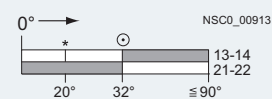

1 NO + 2 NC

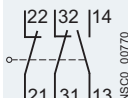

Ident. No. 12

3SE5 1...-KA00 + head²⁾

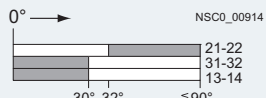

1 NO + 2 NC

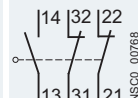

Ident. No. 12

3SE5 1...-LA00 + head²⁾

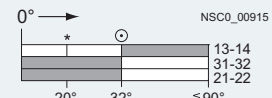

Spring rods

3SE5 1...-R0.

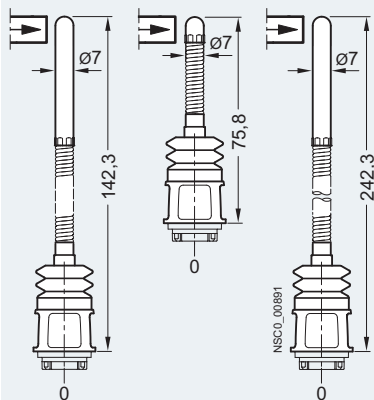

$v_{max} = 1 \text{ m/s}$
 Minimum force required
 in direction of operation: 9 N

The spring rods can be used only with snap-action contacts.

1 NO + 1 NC

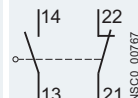

Ident. No. 11

Deflection of spring rod

3SE5 1...-CR01

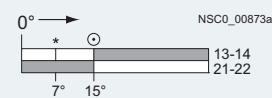

1 NO + 2 NC

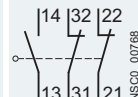

Ident. No. 12

3SE5 1...-LA00 + head²⁾

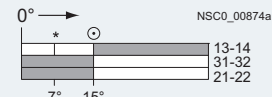

1) Adjustment of the lever in increments of 10°, maximum deflection 90°.

2) The basic switch and actuator head must be ordered separately.

Dimensional drawings

Basic switches

Enclosure width 31 mm, EN 50047, with M20 x 1.5 connecting thread 3SE5 232

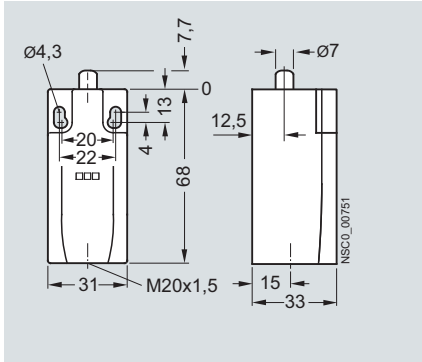

Enclosure width 31 mm, EN 50047, with M12 connector socket 3SE5 234

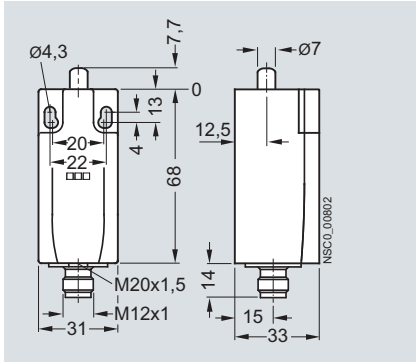

Enclosure width 31 mm, EN 50047, rear with fixing holes 3SE5 232

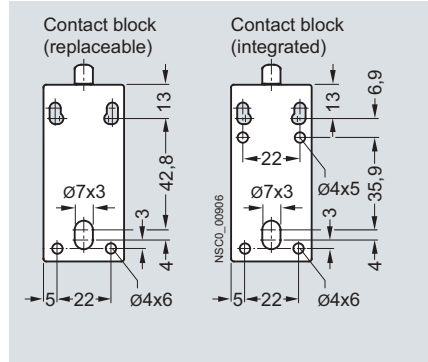

Enclosure width 50 mm, with M20 x 1.5 connecting thread 3SE5 242

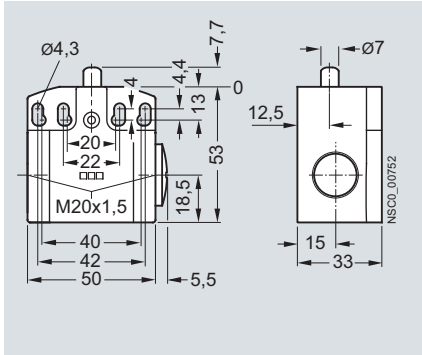

Enclosure width 50 mm, rear with fixing holes 3SE5 242

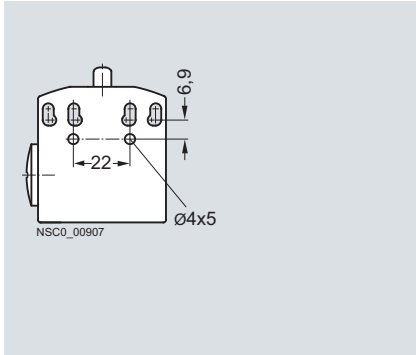

Enclosure width 40 mm, EN 50041, with M20 x 1.5 connecting thread 3SE5 112

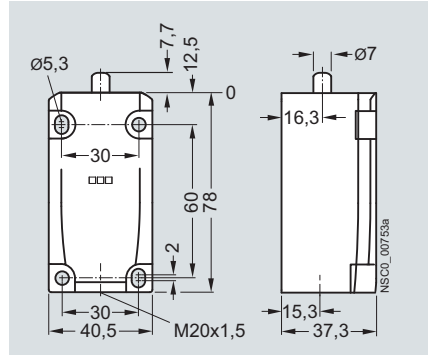

Enclosure width 40 mm, EN 50041, with M12 connector socket 3SE5 114

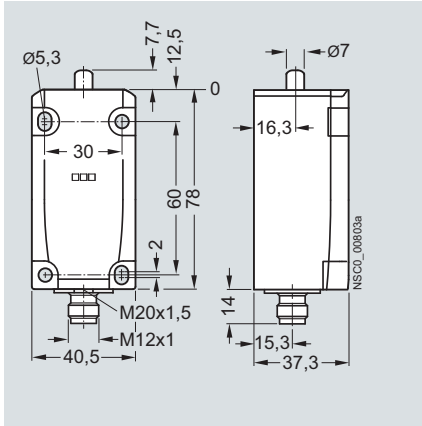

Enclosure width 40 mm, EN 50041, with 6-pole connector socket 3SE5 115

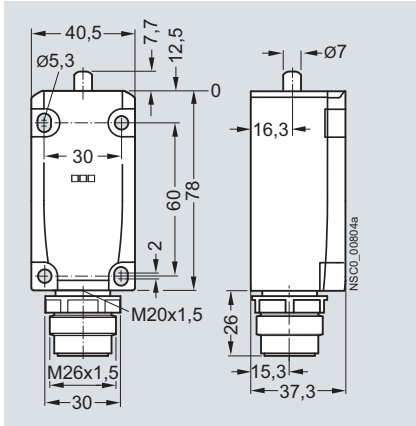

Enclosure width 56 mm, with M20 x 1.5 connecting thread 3SE5 122

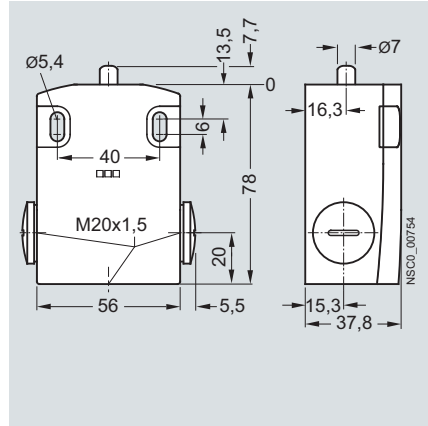

For operating mechanisms for basic switches, see pages 8/18 and 8/19.

3SE5, 3SE2, 3SE3 Position Switches

3SE5, plastic and metal enclosures

Operating mechanisms for enclosure width 31 and 50 mm

Roller plunger, type C acc. to EN 50047

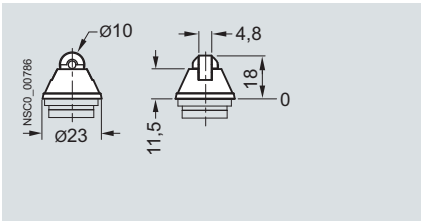

Roller plunger with central fixing

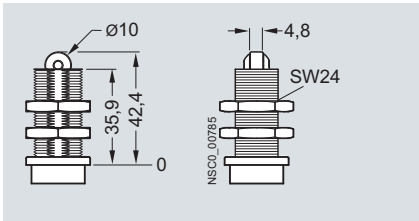

Roller lever, type E acc. to EN 50047

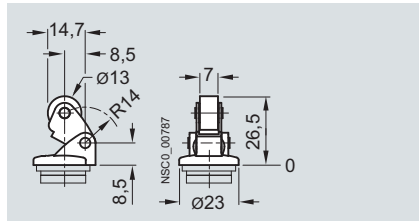

Angular roller lever

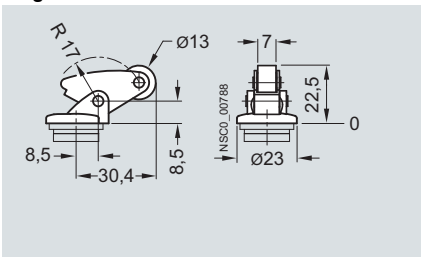

Twist lever, type A acc. to EN 50047

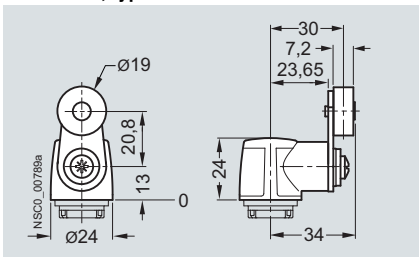

Twist lever, roller 30 mm

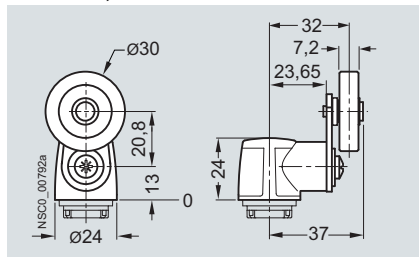

Operating mechanisms for enclosure width 40 mm and 56 mm

Rounded plunger, type B acc. to EN 50041

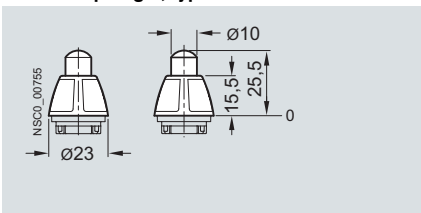

Roller plunger, type C acc. to EN 50041

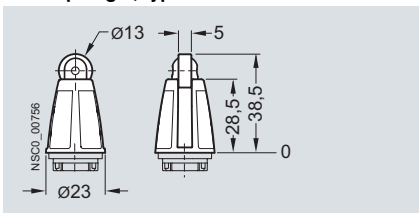

Roller lever

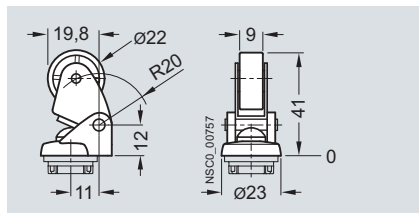

Angular roller lever

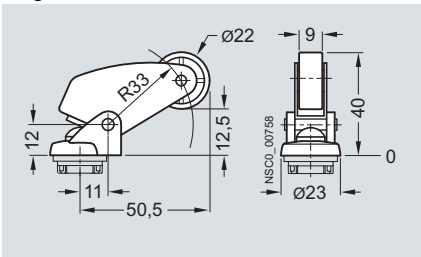

Twist lever, type A acc. to EN 50041

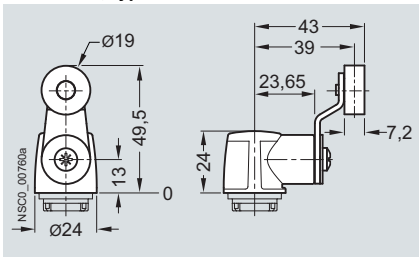

Twist lever, 2 rollers 19 mm

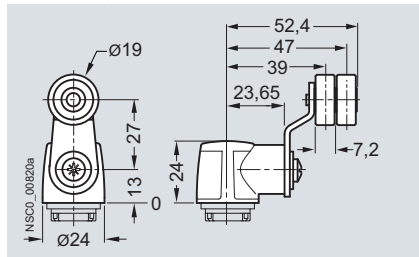

Twist lever, roller 30 mm

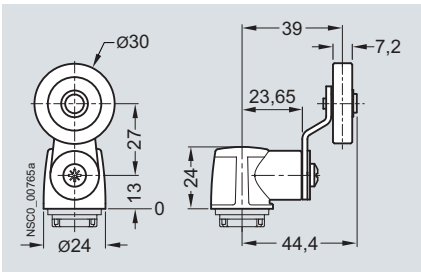

Twist lever, roller 50 mm

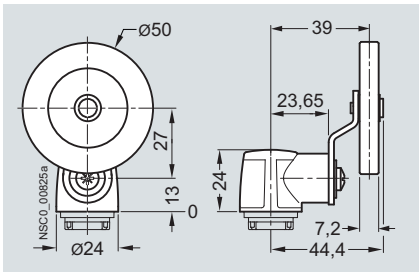

Twist lever, rubber roller 50 mm

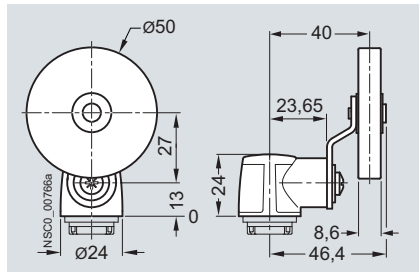

Fork lever

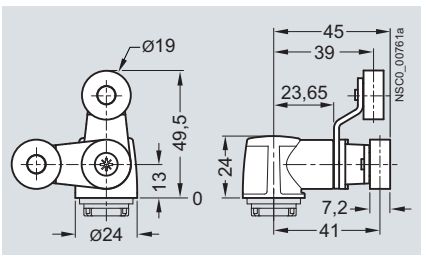

8

Operating mechanisms for all enclosure widths

Twist lever, adjustable length, roller 19 mm

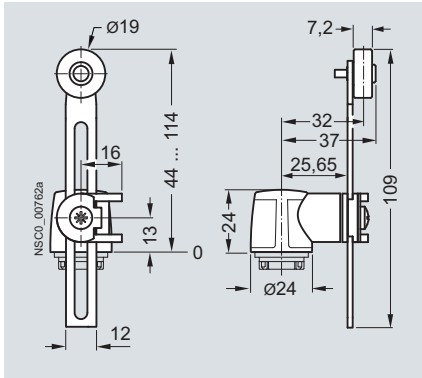

Twist lever, adjustable length, with grid hole, roller 19 mm

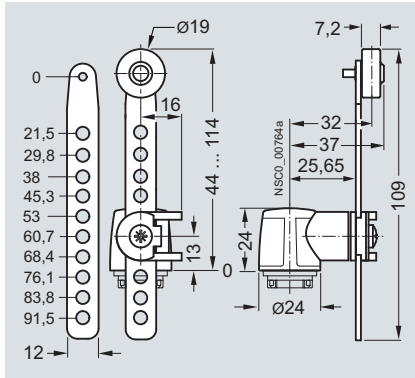

Twist lever, adjustable length, roller 30 mm

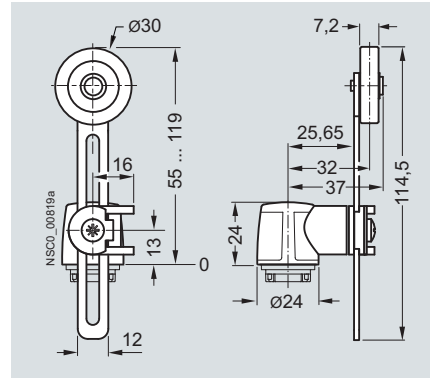

Twist lever, adjustable length, roller 50 mm

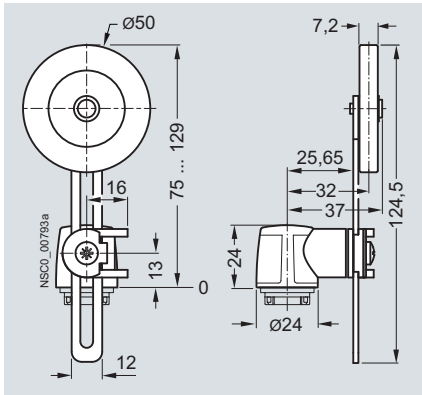

Twist lever, adjustable length, rubber roller 50 mm

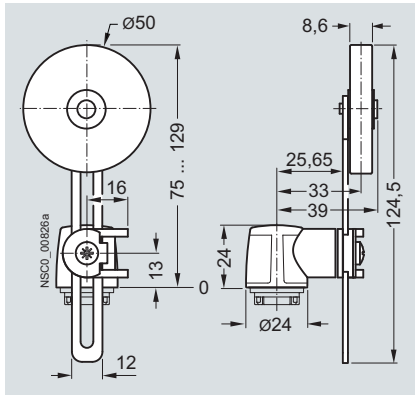

Twist lever, adjustable length, with grid hole, rubber roller 50 mm

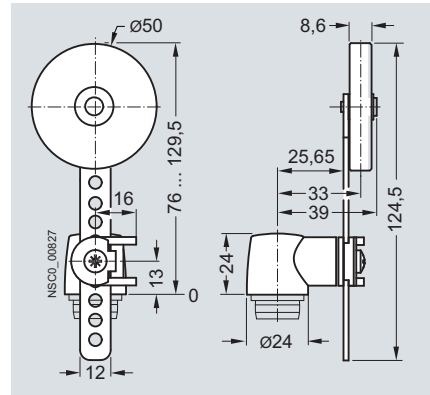

Rod actuator

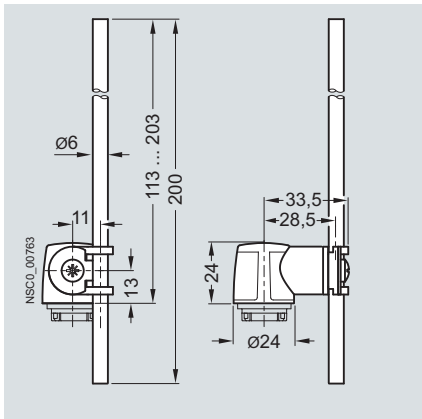

Spring rod, length 142.5 mm

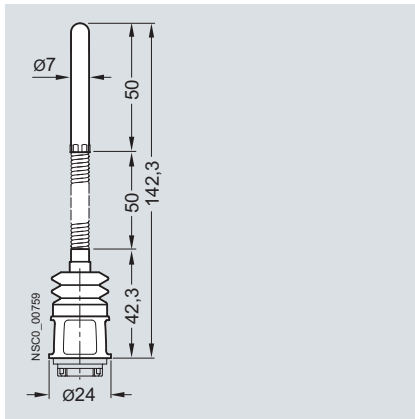

Spring rod, length 242.5 mm

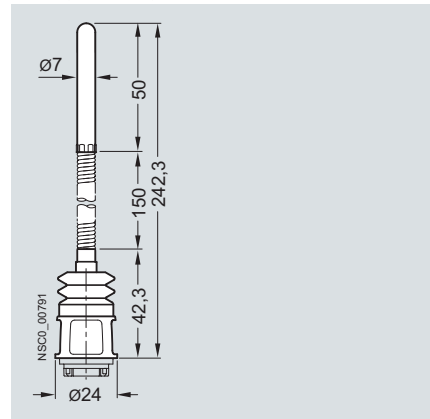

Spring rod, length 76 mm

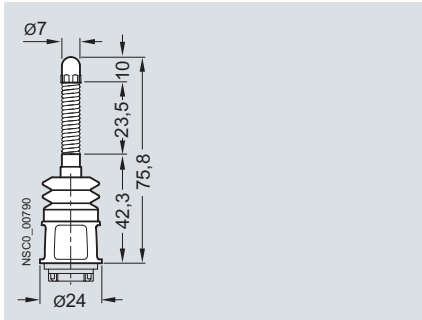

3SE5, 3SE2, 3SE3 Position Switches

3SE2, plastic enclosures Enclosure width 31 mm and 50 mm

Configuration

Operation, actuating speed and travel or angle of actuators

Bars, cams, stops, etc. are used as actuators. The shape of the actuator must provide the given angles for the leading and trailing edges.

Actuating speed in the direction of the plunger axis

The actuating speed in the case of position switches with slow-action contacts is not permitted to go lower than 15 mm/s for DC and 1 mm/s for AC. Position switches with snap-action contacts should be used when the actuating speeds are lower.

Operation by bar (standard)	Contact blocks	Nominal travel (measured)	Contact blocks	Nominal travel
v_{max} Max. actuating speed S Operating travel acc. to EN 50047 H Travel difference → Direction of operation	Terminal designation acc. to EN 50013	0-line Reference line acc. to EN 50047 S Operating travel acc. to EN 50047  ** Positive opening ↻ acc. to IEC 60947-5-1		

Rounded plungers, type B

3SE2 200-C, 3SE2 210-C

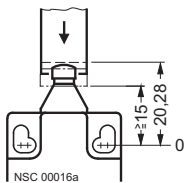

$v_{max} = 1 \text{ m/s}$
 Minimum force required in direction of operation: 9 N

Slow-action contacts

1 NO + 1 NC

Ident. No. **11**

3SE2 2.0-0C

2 NC

Ident. No. **02**

3SE2 2.0-6C

1 NO + 1 NC with make-before-break

Ident. No. **11**

3SE2 2.0-3C

2 NO

Ident. No. **20**

3SE2 2.0-7C

Roller plungers, type C

3SE2 200-D, 3SE2 210-D

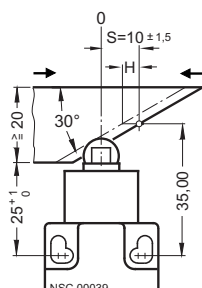

$v_{max} = 1 \text{ m/s}$
 Minimum force required in direction of operation: 9 N

Lateral actuation

Slow-action contacts

1 NO + 1 NC

Ident. No. **11**

3SE2 2.0-0D

2 NC

Ident. No. **02**

3SE2 2.0-6D

1 NO + 1 NC with make-before-break

Ident. No. **11**

3SE2 2.0-3D

2 NO

Ident. No. **20**

3SE2 2.0-7D

3SE5, 3SE2, 3SE3 Position Switches

3SE2, plastic enclosures Enclosure width 31 mm and 50 mm

Operation by bar (standard)	Contact blocks	Nominal travel (measured)	Contact blocks	Nominal travel
v_{max} Max. actuating speed S Operating travel acc. to EN 50047 H Travel difference → Direction of operation	Terminal designation acc. to EN 50013	0-line Reference line acc. to EN 50047 S Operating travel acc. to EN 50047 ■ Contact closed □ Contact open ** Positive opening ↻ acc. to IEC 60947-5-1		

Rounded plungers with central fixing

3SE2 200-L, 3SE2 210-L

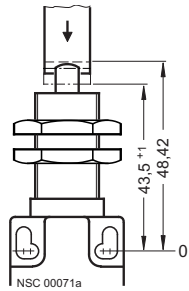

Central fixing with M18 thread
 $v_{max} = 1 \text{ m/s}$
 Minimum force required in direction of operation: 9 N

Slow-action contacts

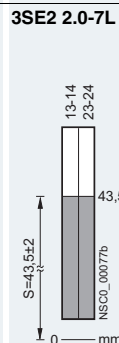
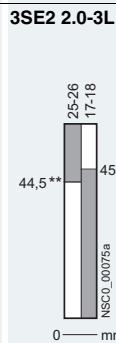
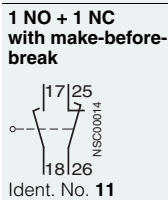
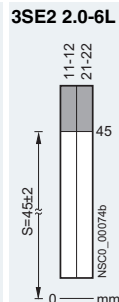
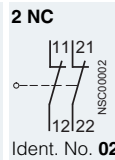
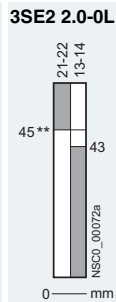
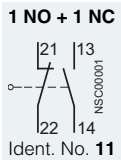

Roller plungers with central fixing

3SE2 200-M, 3SE2 210-M

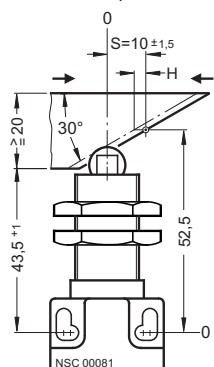

Central fixing with M18 thread
 $v_{max} = 1 \text{ m/s}$
 Minimum force required in direction of operation: 9 N

Slow-action contacts

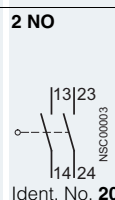
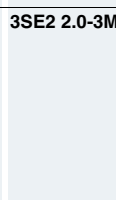
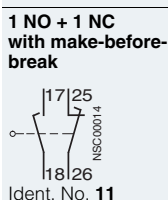
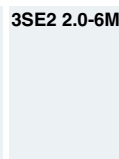
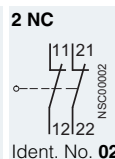
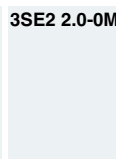
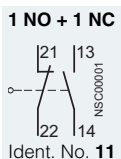

3SE5, 3SE2, 3SE3 Position Switches

3SE2, plastic enclosures Enclosure width 31 mm and 50 mm

Operation by bar (standard)

V_{max} Max. actuating speed
 S Operating travel acc. to EN 50047
 H Travel difference
 → Direction of operation

Contact blocks

Terminal designation acc. to EN 50013

Nominal travel (measured)

0-line Reference line acc. to EN 50047
 S Operating travel acc. to EN 50047

 Contact closed
 Contact open
 ** Positive opening \rightarrow acc. to IEC 60947-5-1

Contact blocks

Nominal travel

Roller levers, type E

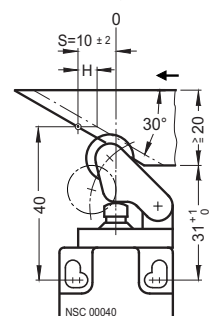
3SE2 200-E, 3SE2 210-E



$V_{max} = 1 \text{ m/s}$
 Minimum force required in direction of operation: 9 N

Slow-action contacts

Lateral actuation

Lateral actuation

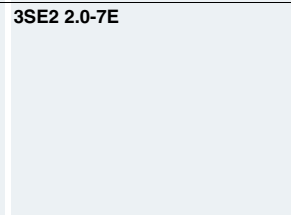
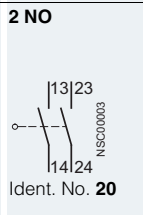
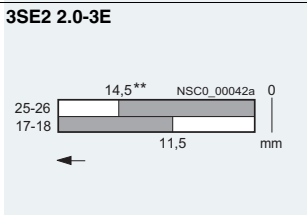
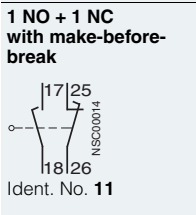
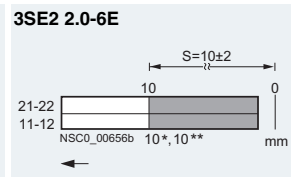
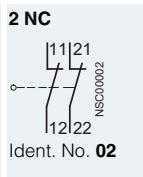
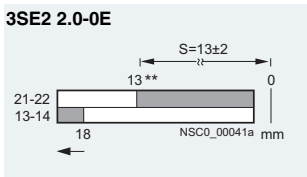
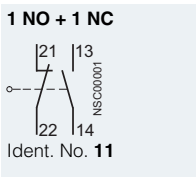

Angular roller levers

3SE2 200-F, 3SE2 210-F

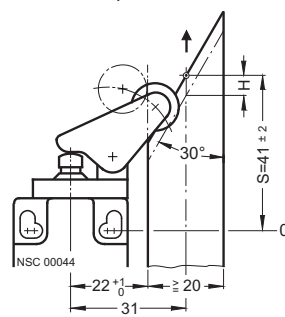

$V_{max} = 1 \text{ m/s}$
 Minimum force required in direction of operation: 9 N
 The example for approach is only applicable to 3SE2 200.
 It is not possible in this way for 3SE2 210.

Slow-action contacts

Actuation along plunger axis

Actuation along plunger axis

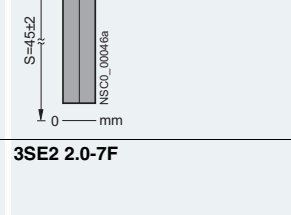
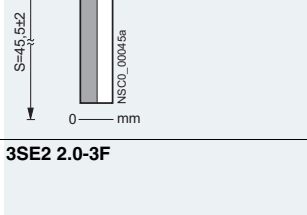
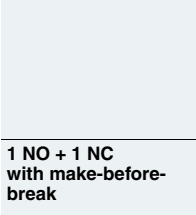
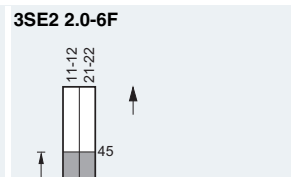
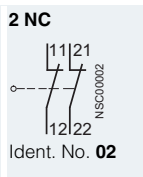
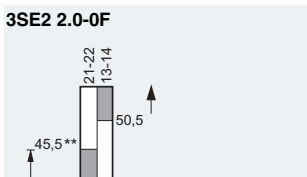
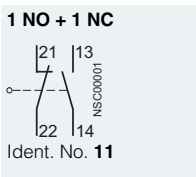

3SE2, plastic enclosures Enclosure width 31 mm and 50 mm

Operation by bar (standard)	Contact blocks	Nominal travel (measured)	Contact blocks	Nominal travel
v_{max} Max. actuating speed S Operating travel acc. to EN 50047 H Travel difference → Direction of operation	Terminal designation acc. to EN 50013	0-line Reference line acc. to EN 50047 S Operating travel acc. to EN 50047 ■ Contact closed □ Contact open ** Positive opening ↻ acc. to IEC 60947-5-1		

Twist levers, type A

3SE2 200-G¹⁾

Lever adjustable in increments of 10°
 $v_{max} = 1$ m/s
 Minimum force required in direction of operation: 18 N

1 NO + 1 NC	3SE2 2.0-0G	2 NC	3SE2 2.0-6G
 Ident. No. 11	 mm NSCO_00052a 21-22 13-14 S=21±2 20°** 65° NSCO_00054a 46°	 Ident. No. 02	 mm NSCO_00053a 11-12 21-22 S=19±2 19
1 NO + 1 NC with make-before-break	3SE2 2.0-3G	2 NO	3SE2 2.0-7G
 Ident. No. 11	 mm NSCO_00055a 25-26 17-18 25** 65° NSCO_00057a 18°	 Ident. No. 20	 mm NSCO_00056b 13-14 23-24 S=50±2 50

Twist levers, adjustable length

3SE2 200-U, 3SE2 210-U

Lever adjustable in increments of 10°
 $v_{max} = 1$ m/s
 Minimum force required in direction of operation: 18 N

1 NO + 1 NC	3SE2 2.0-0U	2 NC	3SE2 2.0-6U
 Ident. No. 11	 mm NSCO_00065a 21-22 13-14 20° 65° 46°	 Ident. No. 02	 mm NSCO_00061a 11-12 21-22 25°
1 NO + 1 NC with make-before-break	3SE2 2.0-3U	2 NO	3SE2 2.0-7U
 Ident. No. 11	 mm NSCO_00066a 25-26 17-18 43° 65° 26°	 Ident. No. 20	 mm NSCO_00063a 13-14 23-24 50°

Rod actuators

3SE2 200-W, 3SE2 210-W 3SE2 200-V, 3SE2 210-V 3SE2 200-S, 3SE2 210-S

Lever adjustable in increments of 10°
 $v_{max} = 1.5$ m/s
 Minimum force required in direction of operation: 18 N

1 NO + 1 NC	3SE2 2.0-0W, -0V, -0S	2 NC	3SE2 2.0-6W, -0V, -0S
 Ident. No. 11	 mm NSCO_00065a 21-22 13-14 20° 65° 46°	 Ident. No. 02	 mm NSCO_00061a 11-12 21-22 25°
1 NO + 1 NC with make-before-break	3SE2 2.0-3W, -0V, -0S	2 NO	3SE2 2.0-7W, -0V, -0S
 Ident. No. 11	 mm NSCO_00066a 25-26 17-18 43° 65° 26°	 Ident. No. 20	 mm NSCO_00063a 13-14 23-24 50°

¹⁾ Not for 3SE2 200-GA. hinge switches.

3SE5, 3SE2, 3SE3 Position Switches

3SE2, plastic enclosures Enclosure width 31 mm and 50 mm

Dimensional drawings

**3SE2 200, narrow enclosure,
with rounded plunger, type B**

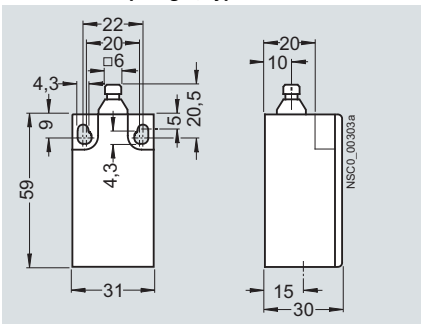

**3SE2 210, wide enclosure,
with rounded plunger, type B**

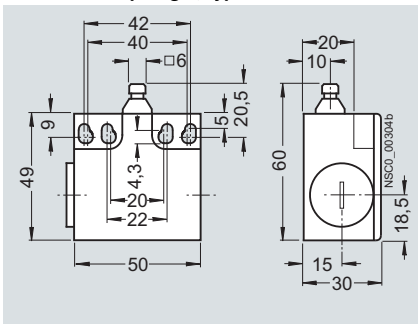

Roller plunger, type C

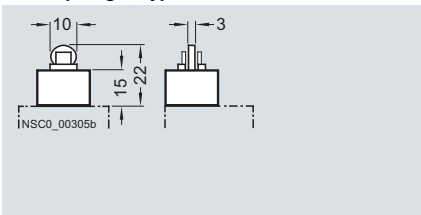

Roller lever, type E

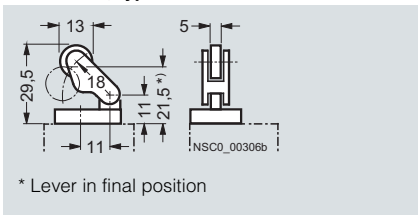

Angular roller lever

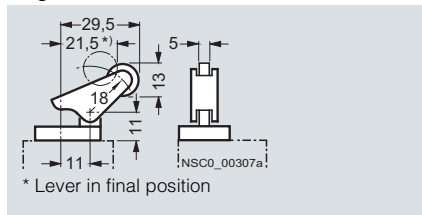

Twist lever, type A

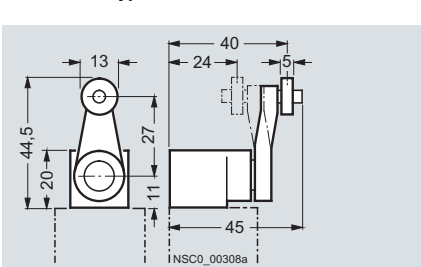

**Rounded plunger,
central fixing with M18 x 1 thread**

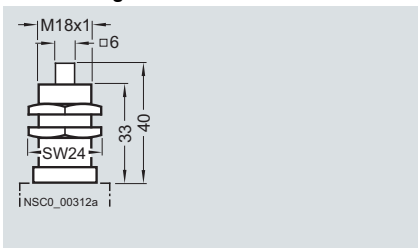

**Roller plunger,
central fixing with M18 x 1 thread**

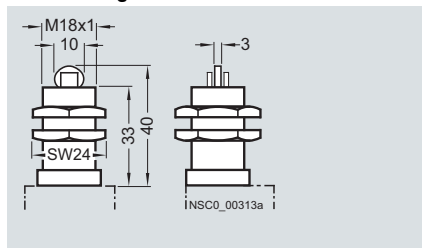

Twist lever, adjustable length

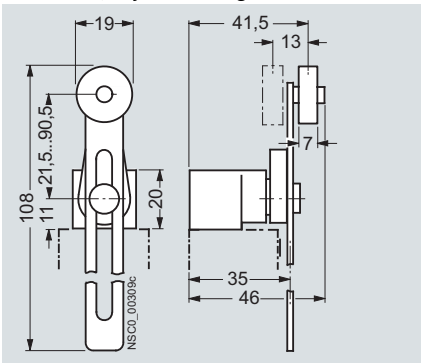

Rod actuator

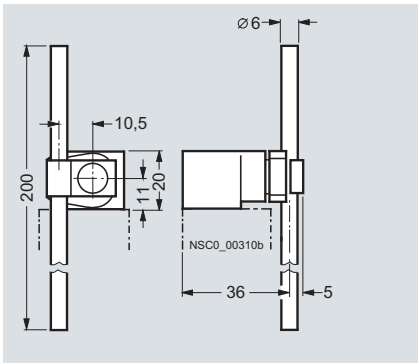

Spring rod

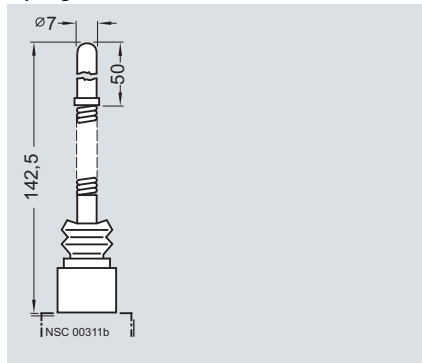

8

3SE2, plastic enclosures
Enclosure width 40 mm

Configuration

See metal enclosures, pages 8/26 to 8/29.

Dimensional drawings

3SE2 230, enclosure acc. to EN 50041, with rounded plunger, type B

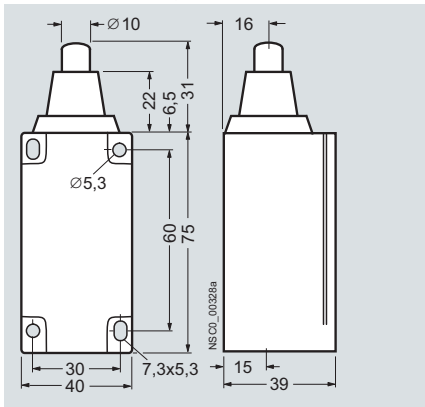

Roller plunger, type C

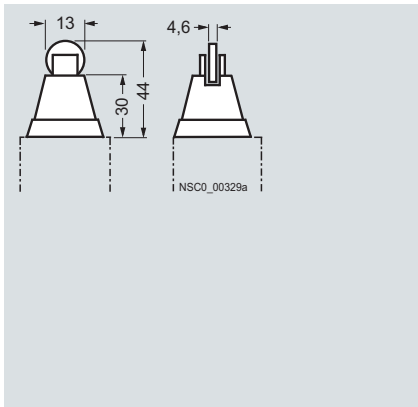

Roller lever

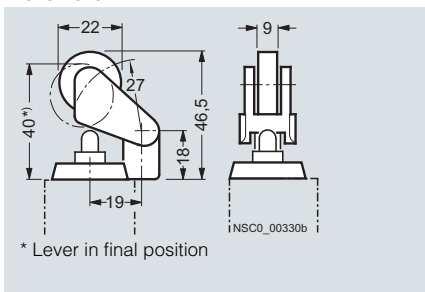

Angular roller lever

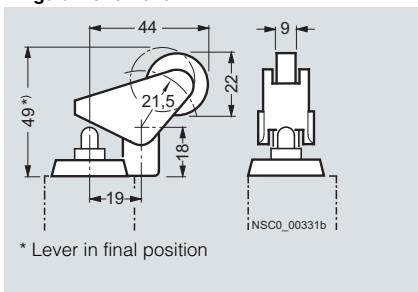

Twist lever, type A

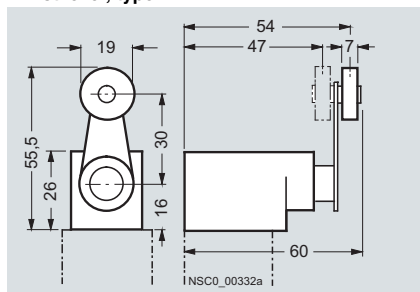

Twist lever, adjustable length

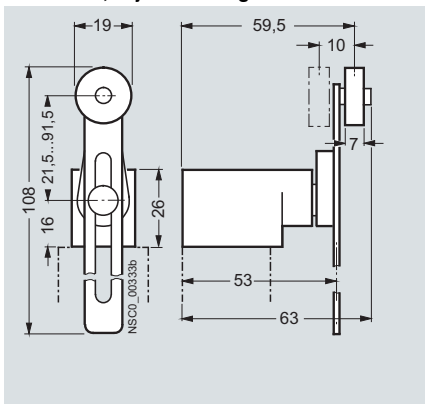

Rod actuator, type D

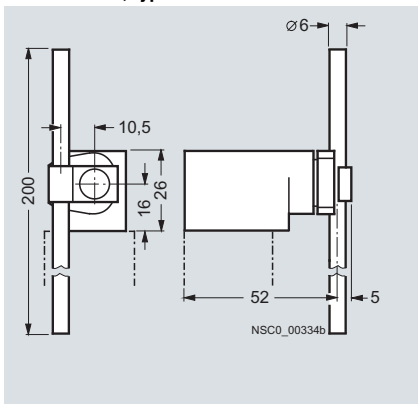

Spring rod

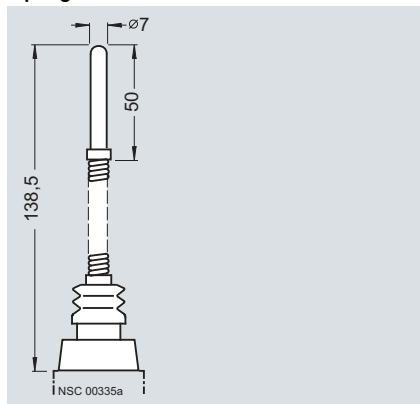

3SE5, 3SE2, 3SE3 Position Switches

3SE2, metal enclosures Enclosure width 40 mm and 56 mm

Configuration

Operation, actuating speed and travel or angle of actuators

Bars, cams, stops, etc. are used as actuators. The shape of the actuator must provide the given angles for the leading and trailing edges.

Actuating speed in the direction of the plunger axis

The actuating speed in the case of position switches with slow-action contacts is not permitted to go lower than 15 mm/s for DC and 1 mm/s for AC. Position switches with snap-action contacts should be used when the actuating speeds are lower.

Position switches with 2 or 4 contacts

Operation by bar (standard)		Slow-action contacts				Snap-action contacts	
O-line	Reference line acc. to EN 50041	1 NO + 1 NC	1 NO + 2 NC	2 NC	2 NO	1 NO + 1 NC	2 NC
S	Operating travel acc. to EN 50041						
H	Travel difference	Ident. No. 11	Ident. No. 12	Ident. No. 02	Ident. No. 20	Ident. No. 11	Ident. No. 02
*	Operating point on return (snap-action)	3SE3 000-0A	3SE3 000-3A	3SE3 000-6A	3SE3 000-7A	3SE3 000-1A	3SE3 000-8AV00
**	Positive opening acc. to EN 60947-5-1	3SE3 010-0A	3SE3 010-3A			3SE3 010-1A	3SE3 010-8AV00
→	Direction of operation						
v _{max}	Max. actuating speed						
	Contact closed						
	Contact open						
	Return travel of the NO contact (snap action)						

Plungers	Actuation along plunger axis			Actuation along plunger axis		
3SE2 100-B, 3SE2 120-B, 3SE2 404-B NSCO 00126a Narrow enclosure Wide enclosure v _{max} = 1.5 m/s Minimum force required in direction of operation: 12 N	3SE2 1.0-3B S=22±2 21-22, 13-14, NSCO_00128a 19, 19,5** 0 mm	3SE2 1.0-7B S=19±2 11-12, 21-22, NSCO_00127a 20,5 0 mm	3SE2 1.0-7B S=20±2 13-14, 23-24, NSCO_00133a 19 0 mm	 S=20±2 21-22, 13-14, NSCO_00134a 19,5** 0 mm	 S=22±2 11-12, 21-22, NSCO_00165b 19,5** 0 mm	

Rounded plungers, type B	Actuation along plunger axis			Actuation along plunger axis		
3SE2 100-C, 3SE2 120-C, 3SE2 230-C, 3SE2 404-C NSCO 00136a Narrow enclosure Wide enclosure v _{max} = 1.5 m/s Minimum force required in direction of operation: 32 N	3SE2 230-0C S=35±2 21-22, 13-14, NSCO_00137a 33, 35 0 mm	3SE2 1.0-3C, 3SE2 230-3C S=30,5** 25-26, 17-18, NSCO_00141a 34,5 0 mm	3SE2 230-6C S=47±2 11-12, 21-22, NSCO_00148b 47 0 mm	3SE2 1.0-7C, 3SE2 230-7C S=32,5±2 13-14, 23-24, NSCO_00143b 32,5 0 mm	3SE2 230-1C S=34,5±2 v31** 21-22, 13-14, NSCO_00144a 34,5, 35,5* 0 mm	3SE2 230-8C S=34,5±2 11-12, 21-22, NSCO_00146b 34,5, 35,5* 0 mm

Angular roller levers	Actuation along plunger axis			Actuation along plunger axis		
3SE2 100-F, 3SE2 120-F, 3SE2 230-F, 3SE2 404-F NSCO 00165 Narrow enclosure Wide enclosure v _{max} = 2.5 m/s Minimum force required in direction of operation: 12 N	3SE2 230-0F S=60±2 21-22, 13-14, NSCO_00166a 60, 65 0 mm	3SE2 1.0-3F, 3SE2 230-3F S=62** 25-26, 17-18, NSCO_00168a 60, 62** 0 mm	3SE2 230-6F S=60±2 11-12, 21-22, NSCO_00167a 60 0 mm	3SE2 1.0-7F, 3SE2 230-7F S=65±2 13-14, 23-24, NSCO_00170a 65 0 mm	3SE2 230-1F S=60±2 21-22, 13-14, NSCO_00171a 58*, 60, 62** 0 mm	3SE2 230-8F S=60±2 11-12, 21-22, NSCO_00172b 58*, 60, 62** 0 mm

3SE2, metal enclosures
Enclosure width 40 mm and 56 mm

Position switches with 2 or 4 contacts

Operation by bar (standard)	Contact blocks	Nominal travel (measured)	Contact blocks	Nominal travel
<ul style="list-style-type: none"> ⊙ Operating point acc. to EN 50041 v_{max} Max. actuating speed 0-line Reference line acc. to EN 50041 H Travel difference → Direction of operation 	Terminal designation acc. to EN 50013	<ul style="list-style-type: none"> 0-line Reference line acc. to EN 50041 S Operating travel acc. to EN 50041 <ul style="list-style-type: none"> ■ Contact closed □ Contact open ▨ Return travel * Operating point on return ** Positive opening ⊕ acc. to IEC 60947-5-1 		

Roller plungers, type C

3SE2 100-D, 3SE2 120-D, 3SE2 230-D, 3SE2 404-D

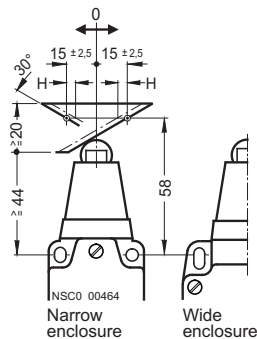

$v_{max} = 1 \text{ m/s}$ (3SE2 230-1D),
 $v_{max} = 0.5 \text{ m/s}$ (3SE2 1.0-1D),
Minimum force required in direction of operation: 32 N

Slow-action contacts

1 NO + 1 NC

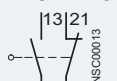

3SE3 000-0A, 3SE3 010-0A, Ident. No. **11**

3SE2 230-0D

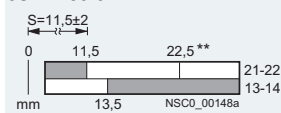

2 NC

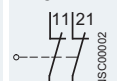

3SE3 000-6A, Ident. No. **02**

3SE2 230-6D

1 NO + 1 NC with make-before-break

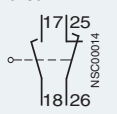

3SE3 000-3A, 3SE3 010-3A, Ident. No. **11**

3SE2 1.0-3D, 3SE2 230-3D

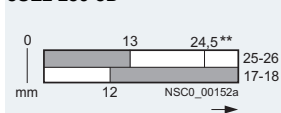

2 NO

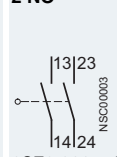

3SE3 000-7A, Ident. No. **20**

3SE2 1.0-7D, 3SE2 230-7D

Snap-action contacts

1 NO + 1 NC

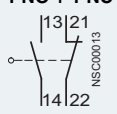

3SE3 000-1A, 3SE3 010-1A, Ident. No. **11**

3SE2 230-1D

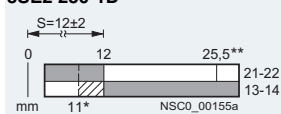

2 NC

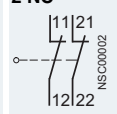

3SE3 000-8AV00, 3SE3 010-8AV00, Ident. No. **02**

3SE2 230-8DV00

Roller levers

3SE2 100-E, 3SE2 120-E, 3SE2 230-E, 3SE2 404-E

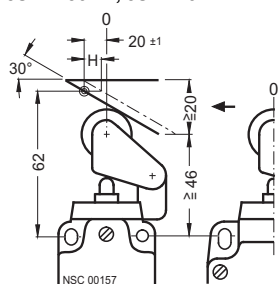

$v_{max} = 2.5 \text{ m/s}$
Minimum force required in direction of operation: 12 N

Slow-action contacts

1 NO + 1 NC

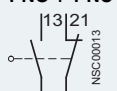

3SE3 000-0A, 3SE3 010-0A, Ident. No. **11**

3SE2 230-0E

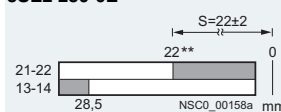

2 NC

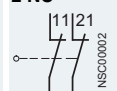

3SE3 000-6A, Ident. No. **02**

3SE2 230-6E

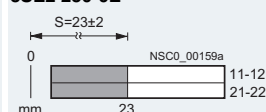

1 NO + 1 NC with make-before-break

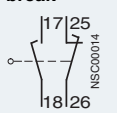

3SE3 000-3A, 3SE3 010-3A, Ident. No. **11**

3SE2 1.0-3E, 3SE2 230-3E

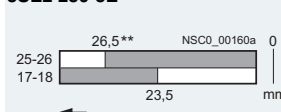

2 NO

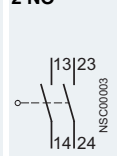

3SE3 000-7A, Ident. No. **20**

3SE2 1.0-7E, 3SE2 230-7E

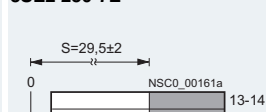

Snap-action contacts

1 NO + 1 NC

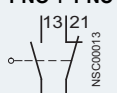

3SE3 000-1A, 3SE3 010-1A, Ident. No. **11**

3SE2 230-1E

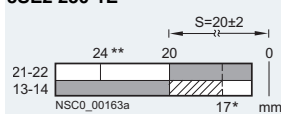

2 NC

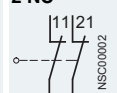

3SE3 000-8AV00, 3SE3 010-8AV00, Ident. No. **02**

3SE2 230-8EV00

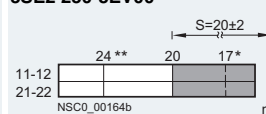

3SE5, 3SE2, 3SE3 Position Switches

3SE2, metal enclosures Enclosure width 40 mm and 56 mm

Position switches with 2 or 4 contacts

Operation by bar (standard)	Contact blocks	Nominal travel (measured)	Contact blocks	Nominal travel
<ul style="list-style-type: none"> ⊙ Operating point acc. to EN 50041 α Approach angle β Trailing angle v_{max} Max. actuating speed 0-line Reference line acc. to EN 50041 S Operating travel acc. to EN 50041 H Travel difference → Direction of operation 	Terminal designation acc. to EN 50013	<ul style="list-style-type: none"> 0-line Reference line acc. to EN 50041 S Operating travel acc. to EN 50041 ■ Contact closed □ Contact open ▨ Return travel * Operating point on return ** Positive opening ⊕ acc. to IEC 60947-5-1 		

Twist levers, type A

3SE2 100–GW, 3SE2 120–GW,
3SE2 230–GW, 3SE2 404–GW

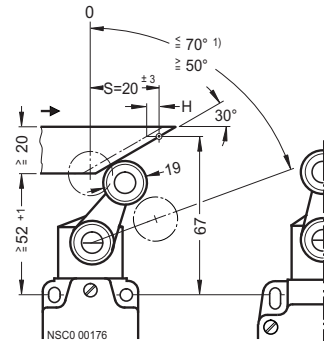

Lever adjustable in increments of 10°
v_{max} = 3 m/s

Minimum torque in direction of operation: 25 Ncm
Contact operation either from right or left or from right and left.

Slow-action contacts

1 NO + 1 NC

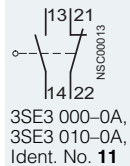

3SE3 000–0A,
3SE3 010–0A,
Ident. No. 11

Lateral actuation/in direction of rotation

3SE2 230-0GW

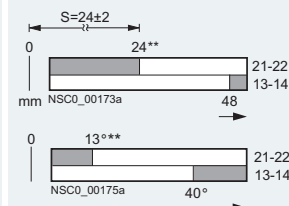

2 NC

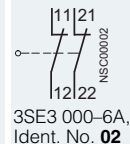

3SE3 000–6A,
Ident. No. 02

Lateral actuation

3SE2 230-6GW

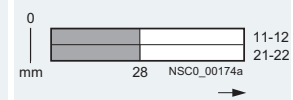

1 NO + 1 NC with make-before-break

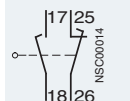

3SE3 000–3A,
3SE3 010–3A,
Ident. No. 11

3SE2 1.0-3GW,
3SE2 230-3GW

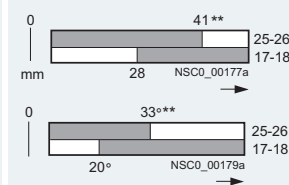

2 NO

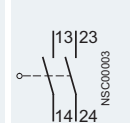

3SE3 000–7A,
Ident. No. 20

3SE2 1.0-7GW,
3SE2 230-7GW

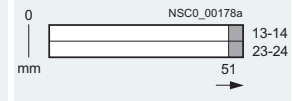

Snap-action contacts

1 NO + 1 NC

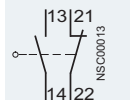

3SE3 000–1A,
3SE3 010–1A,
Ident. No. 11

3SE2 230-1GW

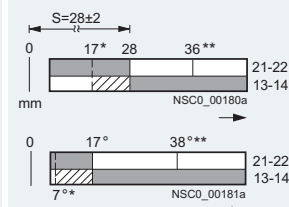

2 NC

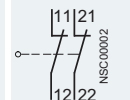

3SE3 000–8AV00,
3SE3 010–8AV00,
Ident. No. 02

3SE2 230-8GW00

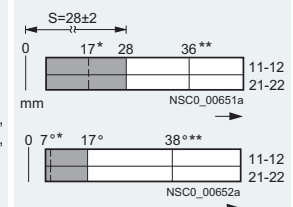

Twist levers, adjustable length

3SE2 100–UW, 3SE2 120–UW,
3SE2 230–U, 3SE2 404–UW

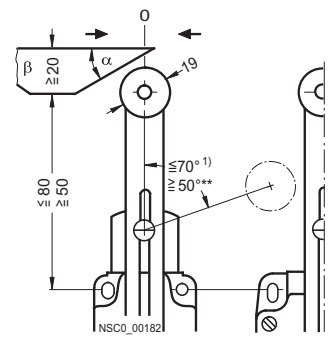

Lever adjustable in increments of 10°
v_{max} = 1 m/s,

α_{max} = 30°, β_{max} = 30°
Minimum torque in direction of operation: 25 Ncm
Contact operation either from right or left or from right and left.

Slow-action contacts

1 NO + 1 NC

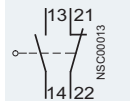

3SE3 000–0A,
3SE3 010–0A,
Ident. No. 11

Deflection in direction of rotation

3SE2 230-0U

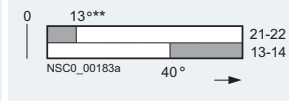

2 NC

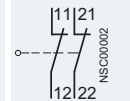

3SE3 000–6A,
Ident. No. 02

Deflection in direction of rotation

3SE2 230-6U

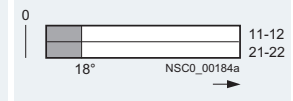

1 NO + 1 NC with make-before-break

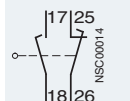

3SE3 000–3A,
3SE3 010–3A,
Ident. No. 11

3SE2 1.0-3UW

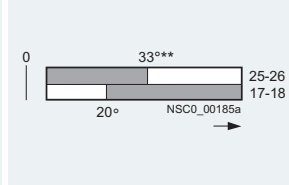

2 NO

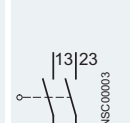

3SE3 000–7A,
Ident. No. 20

3SE2 1.0-7UW,
3SE2 230-7U

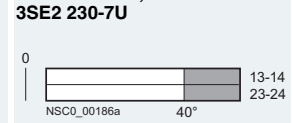

Snap-action contacts

1 NO + 1 NC

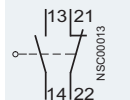

3SE3 000–1A,
3SE3 010–1A,
Ident. No. 11

3SE2 230-1U

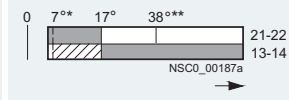

2 NC

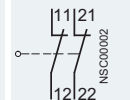

3SE3 000–8AV00,
3SE3 010–8AV00,
Ident. No. 02

3SE2 230-8UW00

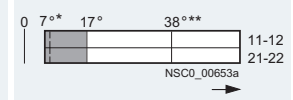

1) Max. operating angle 70°.

3SE2, metal enclosures
Enclosure width 40 mm and 56 mm

Position switches with 2 or 4 contacts

Operation by bar (standard)	Contact blocks	Nominal travel (measured)	Contact blocks	Nominal travel
<p>⊙ Operating point acc. to EN 50041</p> <p>v_{max} Max. actuating speed</p> <p>0-line Reference line acc. to EN 50041</p> <p>→ Direction of operation</p>	Terminal designation acc. to EN 50013	<p>0-line Reference line acc. to EN 50041</p> <p>▬ Contact closed</p> <p>□ Contact open</p> <p>▨ Return travel</p> <p>* Operating point on return</p> <p>** Positive opening acc. to IEC 60947-5-1</p>		

Rod actuators

3SE2 100--.WW, 3SE2 120--.WW, 3SE2 230--.W, 3SE2 404--.WW
3SE2 100--.VW, 3SE2 120--.VW, 3SE2 230--.V, 3SE2 404--.VW

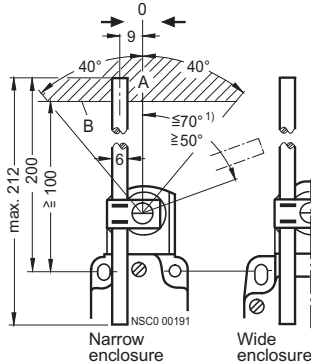

A = Operating range
 B = Lower edge of actuator
 Lever adjustable in increments of 10°

$v_{max} = 3 \text{ m/s}$
 Minimum torque in direction of operation: 25 Ncm
 Contact operation is possible from either right or left. By twisting the plunger from the right and left.

Slow-action contacts

1 NO + 1 NC

3SE3 000-0A, 3SE3 010-0A, Ident. No. **11**

Deflection in direction of rotation

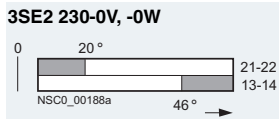

2 NC

3SE3 000-6A, Ident. No. **02**

Deflection in direction of rotation

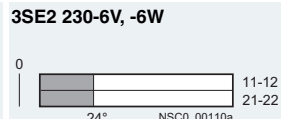

1 NO + 1 NC with make-before-break

3SE3 000-3A, 3SE3 010-3A, Ident. No. **11**

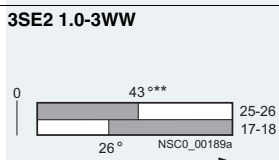

2 NO

3SE3 000-7A, Ident. No. **20**

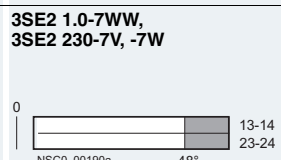

Snap-action contact

1 NO + 1 NC

3SE3 000-1A, 3SE3 010-1A, Ident. No. **11**

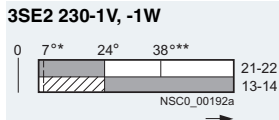

2 NC

3SE3 000-8AV00, 3SE3 010-8AV00, Ident. No. **02**

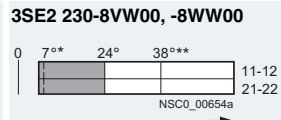

Spring rods

3SE2 230--R

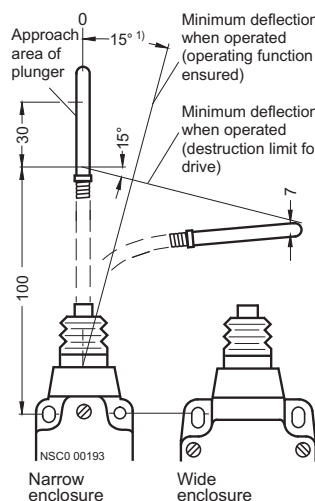

$v_{max} = 1 \text{ m/s}$, approachable from all sides
 Minimum force required in direction of operation: 12 N
 With lateral deflection at the tip: 2.5 N

Snap-action contacts

1 NO + 1 NC

3SE3 000-1A, 3SE3 010-1A, Ident. No. **11**

Deflection of spring rod

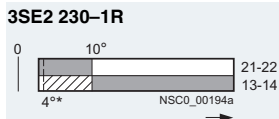

2 NC

3SE3 000-8AV00, 3SE3 010-8AV00, Ident. No. **02**

Deflection of spring rod

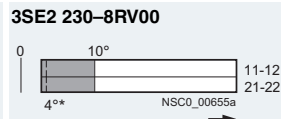



1) Max. operating angle 70°.

3SE5, 3SE2, 3SE3 Position Switches

3SE2, metal enclosures Enclosure width 40 mm and 56 mm

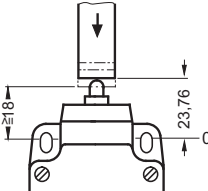
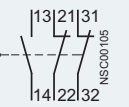
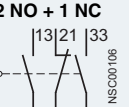
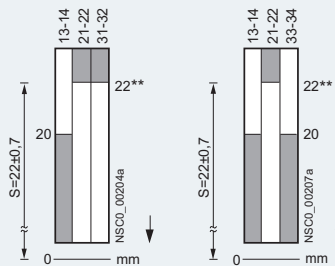
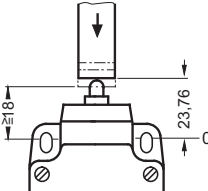
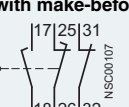
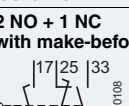
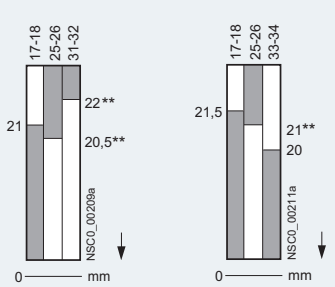
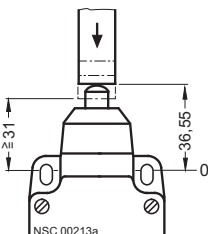
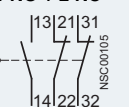
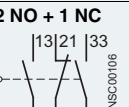
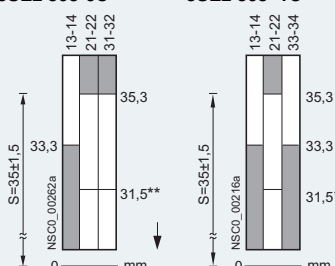
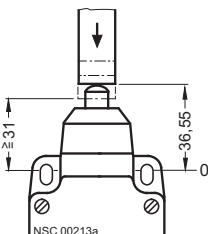

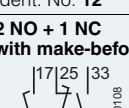
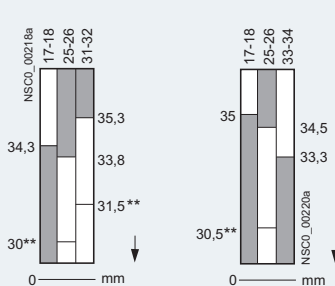

Position switches with 3 contacts

Operation by bar (standard) V_{max} Max. actuating speed 0-line Reference line acc. to EN 50041 → Direction of operation	Contact blocks Terminal designation acc. to EN 50013	Nominal travel (measured) 0-line Reference line acc. to EN 50041 S Operating travel acc. to EN 50041 ■ Contact closed □ Contact open * Operating point on return ** Positive opening acc. to IEC 60947-5-1	Minimum force required in direction of operation
Plungers			
3SE2 303-B  $V_{max} = 1.5 \text{ m/s}$	Slow-action contacts 1 NO + 2 NC  Ident. No. 12 2 NO + 1 NC  Ident. No. 21	Actuation along plunger axis 3SE2 303-0B 3SE2 303-1B  20 mm 20 mm	16 N 18 N
 $V_{max} = 1.5 \text{ m/s}$	1 NO + 2 NC with make-before-break  Ident. No. 12 2 NO + 1 NC with make-before-break  Ident. No. 21	3SE2 303-2B 3SE2 303-3B  21 mm 21.5 mm 20 mm 20 mm	16 N 18 N
Rounded plungers			
3SE2 303-C  $V_{max} = 1.5 \text{ m/s}$	Slow-action contacts 1 NO + 2 NC  Ident. No. 12 2 NO + 1 NC  Ident. No. 21	Actuation along plunger axis 3SE2 303-0C 3SE2 303-1C  33.3 mm 33.3 mm 35.3 mm 35.3 mm 31.5** mm 31.5** mm	35 N 37 N
 $V_{max} = 1.5 \text{ m/s}$	1 NO + 2 NC with make-before-break  Ident. No. 12 2 NO + 1 NC with make-before-break  Ident. No. 21	3SE2 303-2C 3SE2 303-3C  34.3 mm 35 mm 35.3 mm 35 mm 34.5 mm 33.3 mm 30.5** mm 30.5** mm	35 N 37 N

3SE5, 3SE2, 3SE3 Position Switches

3SE2, metal enclosures
Enclosure width 40 mm and 56 mm

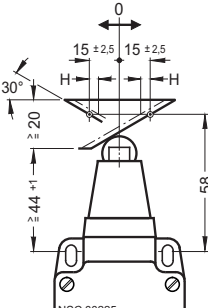
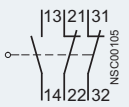
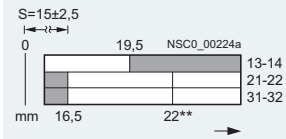
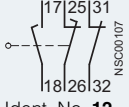
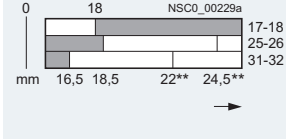
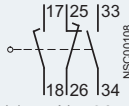
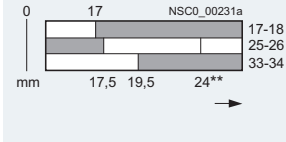
Position switches with 3 contacts



Operation by bar (standard) v_{max} Max. actuating speed 0-line Reference line acc. to EN 50041 H Travel difference → Direction of operation	Contact blocks Terminal designation acc. to EN 50013	Nominal travel (measured) 0-line Reference line acc. to EN 50041 S Operating travel acc. to EN 50041  * Operating point on return ** Positive opening  acc. to IEC 60947-5-1	Minimum force required in direction of operation
Roller plungers 3SE2 303-D  $v_{max} = 1 \text{ m/s}$	Slow-action contacts 1 NO + 2 NC  Ident. No. 12	Lateral actuation 3SE2 303-0D $S=15\pm2,5$ 	35 N
	2 NO + 1 NC  Ident. No. 21	3SE2 303-1D $S=15\pm2,5$ 	37 N
	1 NO + 2 NC with make-before-break  Ident. No. 12	3SE2 303-2D 	35 N
	2 NO + 1 NC with make-before-break  Ident. No. 21	3SE2 303-3D 	37 N



3SE5, 3SE2, 3SE3 Position Switches

3SE2, metal enclosures Enclosure width 40 mm and 56 mm

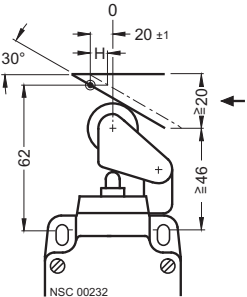
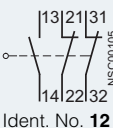
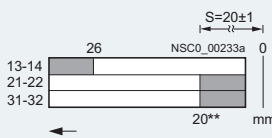
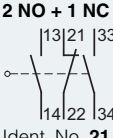
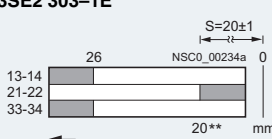
Position switches with 3 contacts

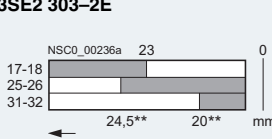
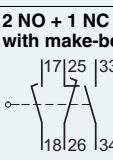
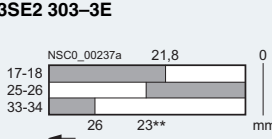
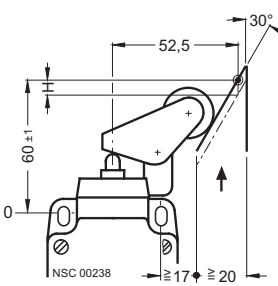
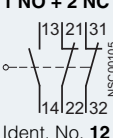
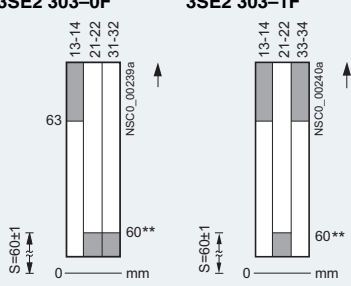
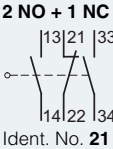
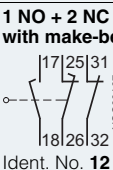
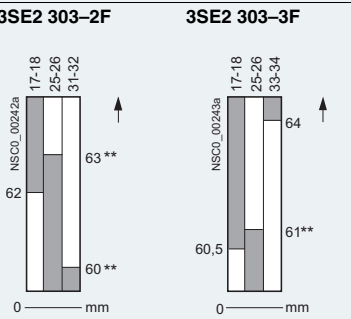
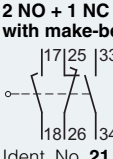
Operation by bar (standard)	Contact blocks	Nominal travel (measured)	Minimum force required in direction of operation
Operation by bar (standard) v_{max} Max. actuating speed 0-line Reference line acc. to EN 50041 H Travel difference → Direction of operation	Contact blocks Terminal designation acc. to EN 50013	Nominal travel (measured) 0-line Reference line acc. to EN 50041 S Operating travel acc. to EN 50041  Contact closed Contact open ** Positive opening \ominus acc. to IEC 60947-5-1	Minimum force required in direction of operation
Roller levers			
3SE2 303-E			
 <p>$v_{max} = 1 \text{ m/s}$</p>	Slow-action contacts 1 NO + 2 NC  Ident. No. 12	Lateral actuation 3SE2 303-0E 	15 N
	2 NO + 1 NC  Ident. No. 21	3SE2 303-1E 	17 N
	1 NO + 2 NC with make-before-break  Ident. No. 12	3SE2 303-2E 	15 N
	2 NO + 1 NC with make-before-break  Ident. No. 21	3SE2 303-3E 	17 N
Angular roller levers			
3SE2 303-F			
 <p>$v_{max} = 1 \text{ m/s}$</p>	Slow-action contacts 1 NO + 2 NC  Ident. No. 12	Actuation along plunger axis 3SE2 303-0F 3SE2 303-1F 	15 N
	2 NO + 1 NC  Ident. No. 21		17 N
	1 NO + 2 NC with make-before-break  Ident. No. 12	3SE2 303-2F 3SE2 303-3F 	15 N
	2 NO + 1 NC with make-before-break  Ident. No. 21		17 N

3SE2, metal enclosures
Enclosure width 40 mm and 56 mm

Position switches with 3 contacts

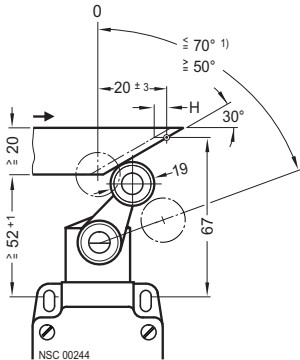
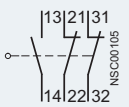
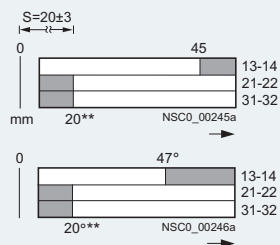
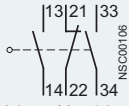
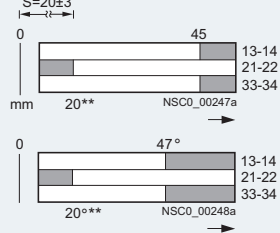
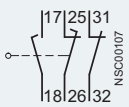
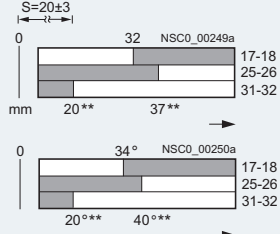
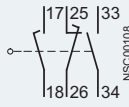
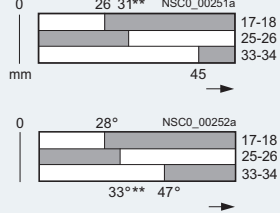
Operation by bar (standard) v_{max} Max. actuating speed 0-line Reference line acc. to EN 50041 H Travel difference → Direction of operation	Contact blocks Terminal designation acc. to EN 50013	Nominal travel (measured) 0-line Reference line acc. to EN 50041 S Operating travel acc. to EN 50041 ■ Contact closed □ Contact open ** Positive opening ↻ acc. to IEC 60947-5-1	Minimum torque in direction of rotation
Twist levers 3SE2 303--GW-Z, Z = A31  <p>Lever adjustable in increments of 10° $v_{max} = 3 \text{ m/s}$ Contact operation is possible from either right or left. By twisting the plunger from the right and left.</p>	Slow-action contacts 1 NO + 2 NC  Ident. No. 12	3SE2 303-0GW Lateral actuation/in direction of rotation 	25 Ncm
	2 NO + 1 NC  Ident. No. 21	3SE2 303-1GW 	25 Ncm
	1 NO + 2 NC with make-before-break  Ident. No. 12	3SE2 303-2GW 	25 Ncm
	2 NO + 1 NC with make-before-break  Ident. No. 21	3SE2 303-3GW 	25 Ncm

¹⁾ Max. operating angle 70°.
 Max. deflection for adjustment purposes 90°.

3SE5, 3SE2, 3SE3 Position Switches

3SE2, metal enclosures Enclosure width 40 mm and 56 mm

Position switches with 3 contacts

Operation by bar (standard)	Contact blocks	Nominal travel (measured)	Minimum torque in direction of rotation
α Approach angle β Trailing angle v_{max} Max. actuating speed 0-line Reference line acc. to EN 50041 \rightarrow Direction of operation	Terminal designation acc. to EN 50013	0-line Reference line acc. to EN 50041 S Operating travel acc. to EN 50041 ■ Contact closed □ Contact open ** Positive opening \oplus acc. to IEC 60947-5-1	

Twist levers, adjustable length

3SE2 303-UW

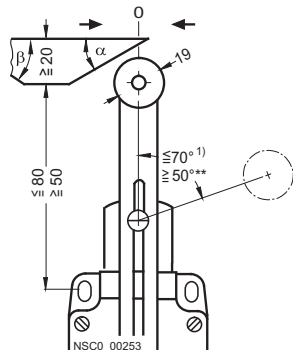

Lever adjustable in increments of 10°

$v_{max} = 3 \text{ m/s}$,
 $\alpha_{max} = 30^\circ$,
 $\beta_{max} = 30^\circ$

Contact operation is possible from either right or left. By twisting the plunger from the right and left.

Slow-action contacts

1 NO + 2 NC

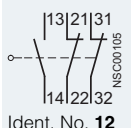

Ident. No. 12

2 NO + 1 NC

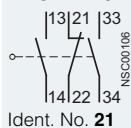

Ident. No. 21

1 NO + 2 NC with make-before-break

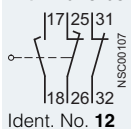

Ident. No. 12

2 NO + 1 NC with make-before-break

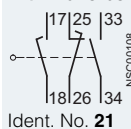

Ident. No. 21

Deflection in direction of rotation

3SE2 303-0UW

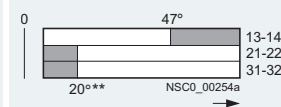

25 Ncm

3SE2 303-1UW

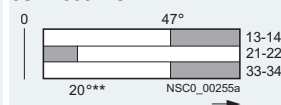

25 Ncm

3SE2 303-2UW

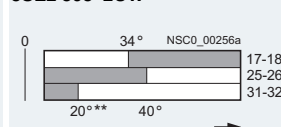

25 Ncm

3SE2 303-3UW

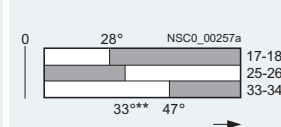

25 Ncm

Rod actuators

3SE2 303-VW, 3SE2 303-WW

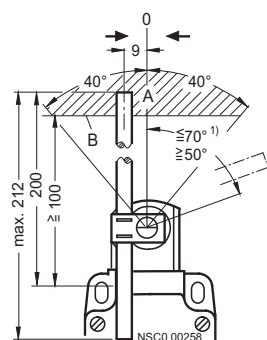

A = Operating range
 B = Lower edge of actuator

Lever adjustable in increments of 10°

$v_{max} = 3 \text{ m/s}$

Contact operation is possible from either right or left. By twisting the plunger from the right and left.

Slow-action contacts

1 NO + 2 NC

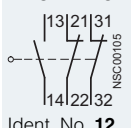

Ident. No. 12

2 NO + 1 NC

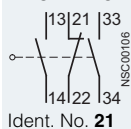

Ident. No. 21

1 NO + 2 NC with make-before-break

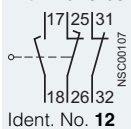

Ident. No. 12

2 NO + 1 NC with make-before-break

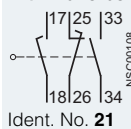

Ident. No. 21

Deflection in direction of rotation

3SE2 303-0VW, 3SE2 303-0WW

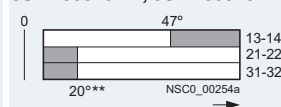

25 Ncm

3SE2 303-1VW, 3SE2 303-1WW

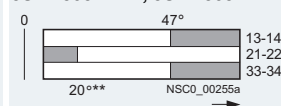

25 Ncm

3SE2 303-2VW, 3SE2 303-2WW

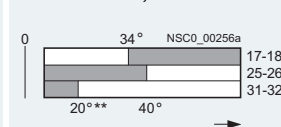

25 Ncm

3SE2 303-3VW, 3SE2 303-3WW

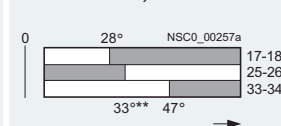

25 Ncm

1) Max. operating angle 70°.
 Max. deflection for adjustment purposes 90°.

Dimensional drawings

3SE2 120
narrow enclosure, 2 contacts,
with plunger

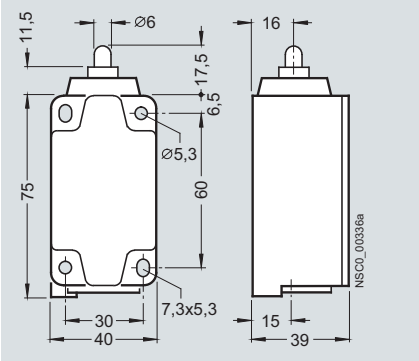

3SE2 100
wide enclosure, 2 contacts,
with plunger

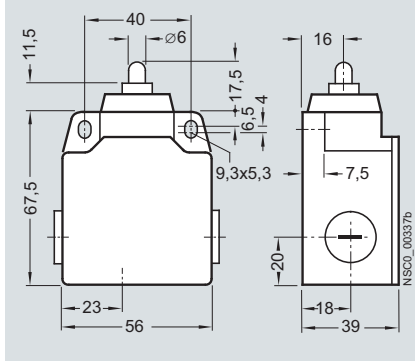

3SE2 303
wide enclosure, 3 contacts

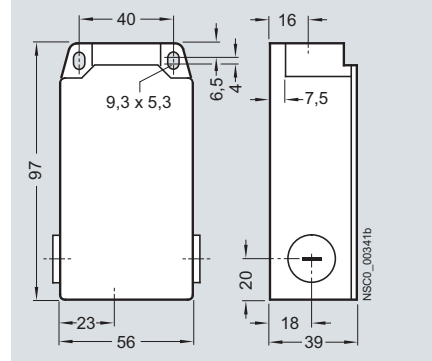

3SE2 404
wide enclosure, 4 contacts

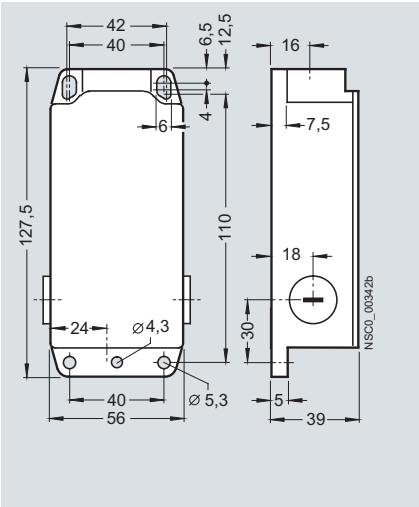

Rounded plunger, type B

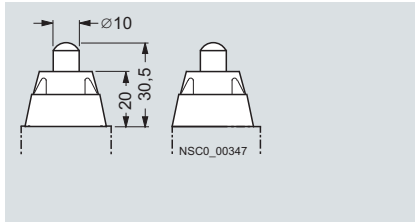

Roller plunger, type C

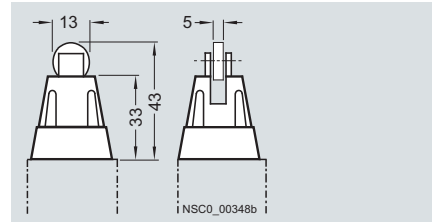

Roller lever

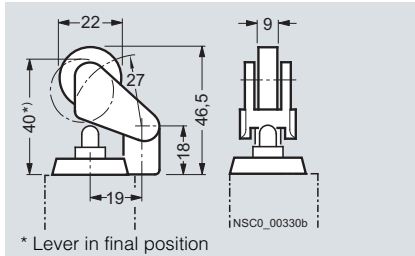

Angular roller lever

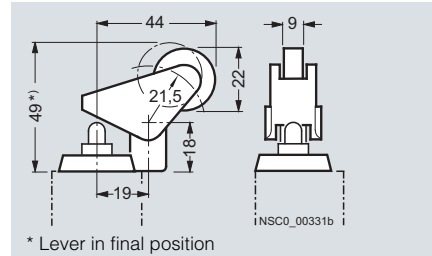

Twist lever, type A

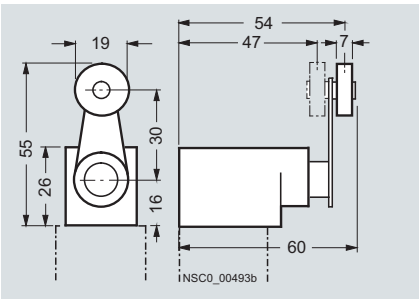

Fork lever

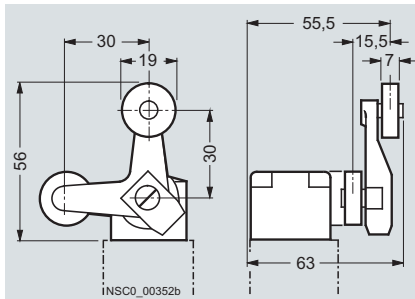

Twist lever, adjustable length

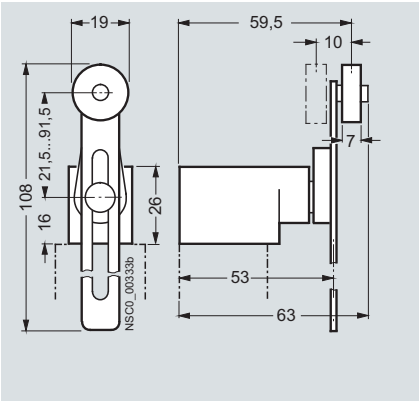

Rod actuator, adjustable length, type D

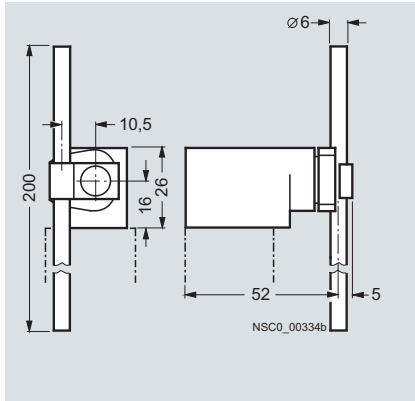

Spring rod

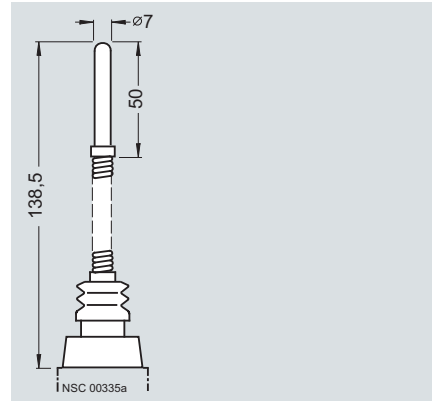

3SE5, 3SE2, 3SE3 Position Switches

3SE3, metal enclosures, compact design with molded cable

Overview

In harsh industrial environments and in installations with limited space, the small 3SE3 160 and 3SE3 180 compact switches are ideal. The switches are already equipped with a molded cable of 2 m in length and can therefore be installed in the smallest of spaces.

Both the enclosure and the actuator head are made of metal and comply with the high IP67 degree of protection. The roller plunger, rounded plunger and twist lever are available as twist actuators.

The contact block is designed with snap-action contacts 1 NO + 1 NC. The NC contact complies with the requirements for positive opening acc. to IEC 60947-5-1.

The 3SE3 1 position switch with molded cable is available in different sizes:

- The 3SE3 180 series complies with the EU standard and features a 30 mm wide enclosure with drilled holes at a distance of 20 mm.
- The 3SE3 160 series meets the requirements of the US market and features a 40 mm wide enclosure with drilled holes at a distance of 25 mm.

Technical specifications

Type	3SE3 160, 3SE3 180	
Rated insulation voltage U_i	V	500
Degree of pollution		Class 3
Rated operational voltage U_e	V	500 AC; over 380 V AC only for equal potential
Conventional thermal current I_{th}	A	10
Mechanical endurance		10×10^6 operating cycles
Electrical endurance		500 000 operating cycles
Switching frequency		30 operating cycles/min
Contact opening	mm	2×1.25
Stroke	mm	5
Actuating speed up to 80 % operating distance		
• 3SE3 1.0-.C.	m/s	≤ 1
• 3SE3 1.0-.D.		
- Vertical	m/s	≤ 1
- Lateral	m/s	≤ 0.5
• 3SE3 1.0-.G.	m/s	≤ 1.5
Connecting cable (2 m)		PVC, $5 \times 0.75 \text{ mm}^2$ (18 AWG)
Terminals		BN-BU: NC, BK-GN/YE: NC, GN/YE: 0 V
Degree of protection		IP67
Ambient temperature	°C	-30 ... +85

Configuration

Contact blocks and operating travel or angle of actuators

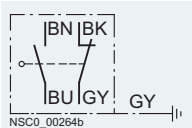
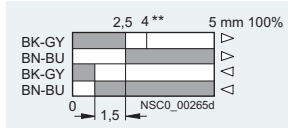
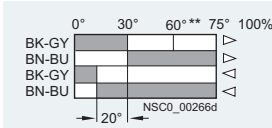
Contact blocks	Nominal travel		
Terminal designation acc. to EN 50013	0-line Reference line acc. to EN 50041		■ Contact closed
	** Positive opening  acc. to IEC 60947-5-1		□ Contact open
Snap-action contacts 1 NO + 1 NC	3SE3 1.0-1C., -1D.	3SE3 1.0-1G	
			Color codes: BK = Black BN = Brown BU = Blue GY = Green/yellow

3SE5, 3SE2, 3SE3 Position Switches

3SE3, metal enclosures, compact design with molded cable

Dimensional drawings

3SE3 180-1C

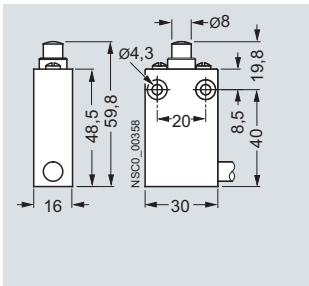

3SE3 160-1C

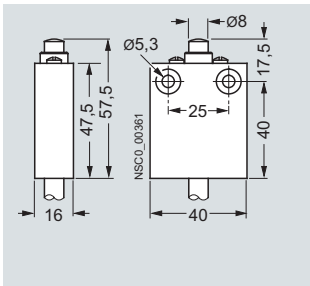

3SE3 180-1CJ

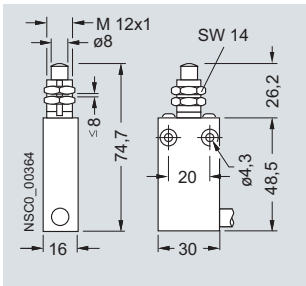

3SE3 160-1CJ

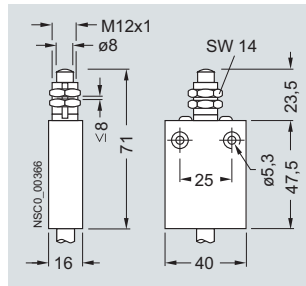

3SE3 180-1D

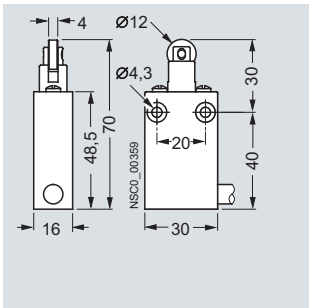

3SE3 160-1D

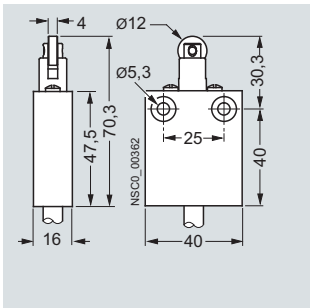

3SE3 180-1DJ

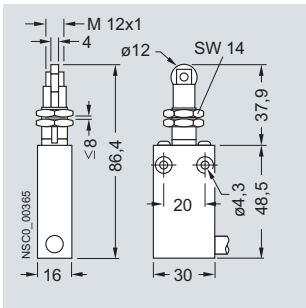

3SE3 160-1DJ

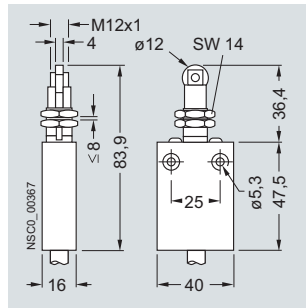

3SE3 180-1G

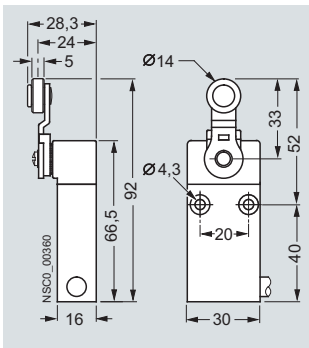

3SE3 160-1G

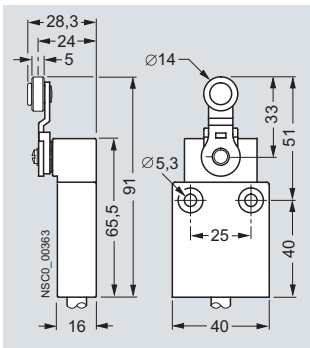

All switches complete with cable, 2 m long

3SE5, 3SE2, 3SE3 Position Switches

Open-Type

3SE5, open-type design

Overview



Their compact design makes these switches particularly suitable for use in confined conditions. The fixing dimensions and operating points are according to EN 50047.

The switches are equipped with two or three contacts in slow-action or snap-action versions. The stroke is 6 mm.

The empty enclosure can be equipped with all switch block variants (see page 8/10).

Configuration

Operation by bar (standard)

- Operating point acc. to EN 50047 (snap-action)
- * Operating point on return (snap-action)
- ** Positive opening acc. to EN 60947-5-1
- v_{max} Max. actuating speed
- 0-line Commencement of plunger travel
- Direction of operation
- Contact closed
- Contact open

Slow-action contacts

1 NO + 1 NC

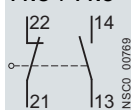

Ident. No. 11

1 NO + 2 NC

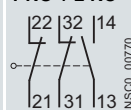

Ident. No. 12

Snap-action contacts

1 NO + 1 NC

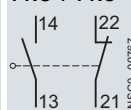

Ident. No. 11

1 NO + 2 NC

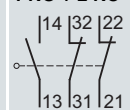

Ident. No. 12

Rounded plungers

3SE5 250-0. C05

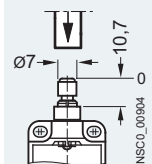

$v_{max} = 0.5 \text{ m/s}$
Minimum force required in direction of operation: 9 N

Actuation along plunger axis

-0BC05

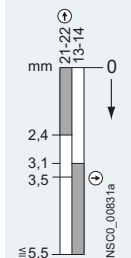

-0KC05

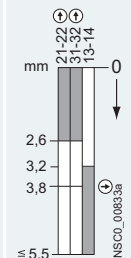

Actuation along plunger axis

-0CC05

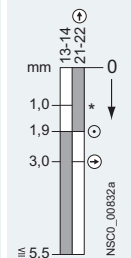

-0AC05¹⁾

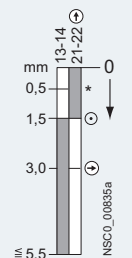

Short stroke

-0AC05¹⁾

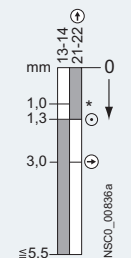

Switching interval $2 \times 2 \text{ mm}$

-0LC05

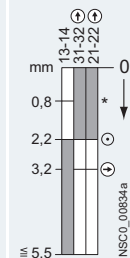

¹⁾ The empty enclosure and contact block must be ordered separately.

Dimensional drawings

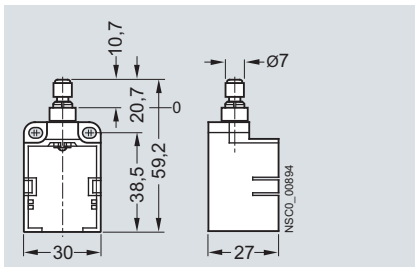

Configuration

Operation, actuating speed and travel of actuators

Operation by bar (standard)	Slow-action contacts	Snap-action contacts
* Operating point on return (snap-action) ** Positive opening acc. to EN 60947-5-1 v_{max} Max. actuating speed 0-line Commencement of plunger travel → Direction of operation 	1 NO + 1 NC Ident. No. 11	1 NO + 1 NC with make-before-break Ident. No. 11
1 NO + 1 NC Ident. No. 11		

Rounded plungers	Actuation along plunger axis	Actuation along plunger
3SE3 020-A, 3SE3 023-A Actuation along plunger axis: $v_{max} = 1.5$ m/s Lateral actuation: 	3SE3 020-0A Minimum force required along plunger axis 8 N	3SE3 020-1A Minimum force required along plunger axis 6 N
	3SE3 020-3A Minimum force required along plunger axis 8 N	

Actuators can be in the form of a bar, cam, stop etc.
 $A \geq 15$ mm; $A^{**} \geq 17.5$ mm
 A = Actuating bar spacing = Distance from center of the fixing hole up to lower edge of the contact bar
 A^{**} = Actuating bar spacing for positive opening acc. to IEC 60204-1 (VDE 0113 Part 1) for snap-action contacts
 $\alpha_{max} = 30^\circ$, $\beta_{max} = 30^\circ$
 $v_{max} = 0.5$ m/s

Slow-action contacts	Actuation along plunger axis	Actuation along plunger
1 NO + 2 NC Ident. No. 12	2 NO + 1 NC Ident. No. 21	1 NO + 2 NC with make-before-break Ident. No. 12
		2 NO + 1 NC with make-before-break Ident. No. 21
3SE3 023-0A Minimum force required along plunger axis 11 N	3SE3 023-1A Minimum force required along plunger axis 13 N	3SE3 023-2A Minimum force required along plunger axis 11 N
		3SE3 023-3A Minimum force required along plunger axis 13 N

Dimensional drawings

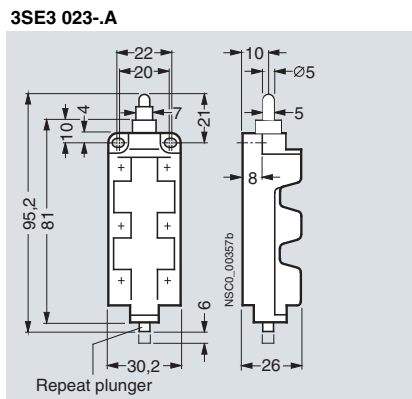
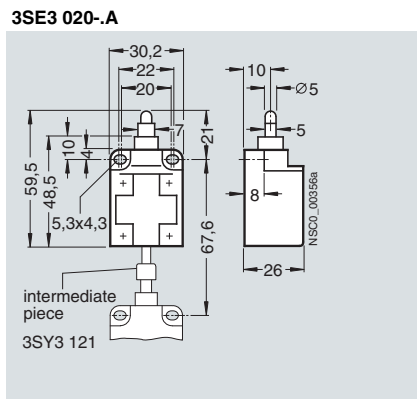

3SE5, 3SE2, 3SE3 Position Switches With Separate Actuator

General data

Overview

Position switches with separate actuator are used where the position of doors, covers or protective grills must be monitored for safety reasons.

3SE5 position switches with separate actuator have the same enclosures as the standard switches (modular system).



Design

Enclosure sizes

The 3SE5 switches are available in various enclosure sizes:

- Plastic enclosures according to EN 50047 (31 mm wide), 1 cable entry
- Plastic enclosures (50 mm wide), 2 cable entries
- Metal enclosures according to EN 50041 (40 mm wide), 1 cable entry
- Metal enclosures (56 mm wide), 3 cable entries

Also available is a switch in the 3SE2 series, which has arisen in this form according to general market requirements:

- Plastic enclosures outside of the standards, enclosure width 52 mm.

Enclosure versions

Various basic versions can be selected for the enclosures of the 3SE5 series:

- Available with two- or three-pole switching elements designed as slow-action contacts
- Optional LED status display
- With mounted four or five-pole M12 connector socket (available for the wide enclosures as an accessory for self-assembly)
- With 6-pole connector socket + PE on the metal enclosures
- Similarly with a combination of connector socket and LED indicators
- With increased corrosion protection
- Metal enclosures for explosion protection (ATEX) ([see page 8/55](#))
- AS-Interface version with integrated ASIsafe electronics for all enclosure designs ([see page 8/56](#))

Operation

The actuator head is included in the scope of supply. For actuation from four directions it can be adjusted through $4 \times 90^\circ$. The switches can also be approached from above.

The actuator head of the 3SE2 243 and 3SE2 257 switches with special enclosures cannot be changed. The switches can be approached from the two broad sides and from above.

The actuators are not included in the scope of supply of the position switches and must be ordered separately from a choice of six versions to suit the application.

The actuator is encoded. Simple overruling by hand or auxiliary devices is impossible.

Radius actuators

The position switches with radius actuators are particularly suitable for rotatable protective devices. The movable actuation key allows even small radii to be approached. Damage to the switch and the actuator due to inaccurate approach is prevented.

Locking devices

A high-grade steel blocking insert for attaching up to eight padlocks is available for even more safety.



Blocking inserts with padlock

Dust protection

A rubber cap to protect the actuator head from contamination is available for operation in dusty environments.

Contact reliability

The new switching blocks ensure an extremely high contact stability. This applies even when the devices are switching low voltages and currents, e. g. 1 mA at 5 V DC.

Positive opening

The NC contacts of the switch are forced open mechanically, positively-driven and reliably by the plunger. This is referred to as "positive opening".

3SE5, 3SE2, 3SE3 Position Switches

With Separate Actuator

General data

Technical specifications

Type	3SE5 1...-V., 3SE5 2...-V..	
General data		
Standards	IEC 60947-5-1, EN 60947-5-1	
Rated insulation voltage U_i	V	400
Degree of pollution acc. to EN 60664-1	Class 3	
Rated impulse withstand voltage U_{imp}	kV	6
Rated operational voltage U_e	V	400 AC; over 300 V AC only for equal potential
Conventional thermal current I_{th}	A	6
Rated operational current I_e		2-pole 3-pole
• With alternating current 50/60 Hz		I_e /AC-15 I_e /AC-15
- At 24 V	A	6 6
- At 120 V	A	6 3
- At 240 V	A	3 1.5
• For direct current		I_e /DC-13 I_e /DC-13
- At 24 V	A	3 3
- At 125 V	A	0.55 0.55
- At 250 V	A	0.27 0.27
Short-circuit protection¹⁾		
• With DIAZED fuse links, operational class gG	A	6
• With miniature circuit breaker, Char. C	A	1
Mechanical endurance	1 × 10 ⁶ operating cycles	
Electrical endurance		
• With 3RH11, 3RT10 16 to 3RT10 26 contactors	10 × 10 ⁶ operating cycles	
• For AC-15 utilization category	0.1 × 10 ⁶ operating cycles when interrupting I_e /AC-15 at 240 V	
• For DC-13 utilization category	With DC current the endurance of the switching element depends not only on the breaking current but also on the voltage, the circuit inductance and the speed of switching. No generally valid information can be given.	
Switching frequency With 3RH11, 3RT10 16 to 3RT10 26 contactors	6000 operating cycles/h	
Operating point with snap-action contacts	Independent of contact erosion, constant throughout the endurance of the switch	
Rated data acc. to \mathbb{E}, \mathbb{Q} and \mathbb{N}.		
• Rated voltage	V	300
• Uninterrupted current	A	6
• Switching capacity	Heavy duty, A 300/ B 300 /Q 300	

Type	3SE5 23.	3SE5 24.	3SE5 11.	3SE5 12.
Enclosure				
Enclosure				
• Material	Ultramid A3X2G7		Zinc diecasting GD Zn Al4 Cu1	
• Width	mm	31	50	40 56
• Dimensions acc. to EN		EN 50047	--	EN 50041 --
Degree of protection acc. to EN 60529		IP65	IP66/IP67	
Ambient temperature				
• During operation	°C	-25 ... +85		
• In operation, switch with LEDs	°C	-25 ... +70		
• Storage, transport	°C	-40 ... +90		
Mounting position	Any			
Connection				
Cable entry		1 × (M20 × 1.5)	2 × (M20 × 1.5)	1 × (M20 × 1.5) 3 × (M20 × 1.5)
Conductor cross-sections²⁾				
• Solid	mm ²	2 × (0.5 ... 1.5)		
• Finely stranded with end sleeve	mm ²	2 × (0.5 ... 1.5)		
Tightening torque , contact block	NM	0.8 ... 1.0		
Protective conductor connection inside enclosure		--	M3.5	

¹⁾ Without any welds according to EN 60947-5-1.

²⁾ For the maximum number of connectable conductors for the respective contact block see operating instructions. Download from:
<http://www.siemens.com/automation/service&support>

3SE5, 3SE2, 3SE3 Position Switches

With Separate Actuator

General data

Type	3SE2 257-XX..		3SE2 243-XX..	
General data				
Standards	IEC 60947-5-1, EN 60947-5-1			
Rated insulation voltage U_i	V	500		
Degree of pollution acc. to EN 60664-1	Class 3			
Rated operational voltage U_e	V	500 AC; over 380 V AC only for equal potential		
Conventional thermal current I_{th}	A	10		
Rated operational current I_e				
• For alternating current 40 ... 60 Hz				
- At 24 V	A	I_e /AC-12	I_e /AC-15	I_e /AC-12
- At 125 V	A	10	10	10
- At 230 V	A	10	6	10
- At 400 V	A	10	4	10
- At 500 V	A	10	3	10
• For direct current				
- At 24 V	A	I_e /DC-12	I_e /DC-13	
- At 48 V	A	10	10	
- At 110 V	A	6	4	
- At 220 V	A	4	1	
- At 220 V	A	1	0.4	
- At 440 V	A	0.5	0.2	
Short-circuit protection¹⁾ , DIAZED fuse links				
• gL/gG operational class	A	6		
• Characteristic quick	A	10		
Mechanical endurance				
> 1×10^6 operating cycles				
Electrical endurance				
• With 3RH11, 3RT10 16 to 3RT10 26 contactors				
> 1×10^6 operating cycles				
• For AC-15 utilization category				
0.5 $\times 10^6$ operating cycles when interrupting I_e /AC-15 at 230 V				
• For DC-13 utilization category				
With DC current the contact endurance depends not only on the breaking current but also on the voltage, the circuit inductance and the speed of switching. No generally valid information can be given.				
Switching frequency				
With 3RH11, 3RT10 16 to 3RT10 26 contactors				
6×10^3 operating cycles/h				

Type	3SE2 243, 3SE2 257	3SE2 243, 3SE2 257
Enclosure		
Enclosure		
• Material	Fiber-glass strengthened thermoplast	
• Type acc. to EN	--	
• Width	52 mm	
Degree of protection acc. to EN 60529	IP67	
Ambient temperature		
• During operation	-30 ... +85 °C	
• During storage, transport	--	
Mounting position	Any	
Connection		
Cable entry	1 × (M20 × 1.5)	1 × (M16 × 1.5)
Conductor cross-sections		
• Solid	1 × (0.5 ... 1.5 mm ²), 2 × (0.5 ... 1 mm ²)	
• Finely stranded with end sleeve	1 × (0.5 ... 1.5 mm ²), 2 × (0.5 ... 1 mm ²)	
Protective conductor connection Inside enclosure	--	

¹⁾ Without any welds according to IEC 60947-5-1.

3SE5, 3SE2, 3SE3 Position Switches With Separate Actuator

3SE5, plastic and metal enclosures

Configuration

Operation and operating travel of actuators

Operation by a separate actuator Positive opening acc. to EN 60947-5-1 v_{max} Max. actuating speed Direction of operation	Contact blocks Terminal designation acc. to EN 50013	Nominal travel Contact closed Contact open Actuator in actuator head: NC is closed
--	--	--

Separate actuators

Standard actuators

Axial and lateral actuation ($4 \times 90^\circ$)

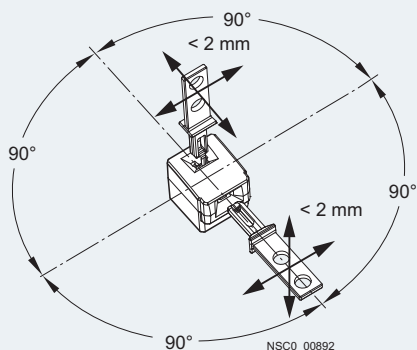

Minimum force required in operating direction 30 N (on retraction)

Slow-action contacts

1 NO + 1 NC

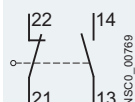

Ident. No. 11

Lateral actuation

3SE5 ...-RV..

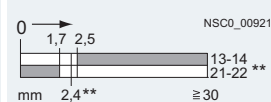

Axial actuation

3SE5 ...-RV..

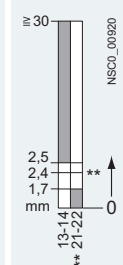

1 NO + 2 NC

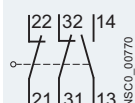

Ident. No. 12

3SE5 ...-QV..

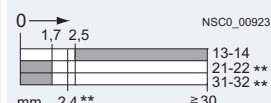

3SE5 ...-QV..

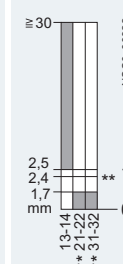

Radius actuators (all directions of approach)

Example: direction of approach from the left

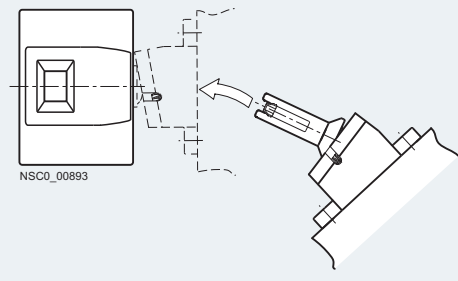

For connector assignment, see page 8/10.

3SE5, 3SE2, 3SE3 Position Switches With Separate Actuator

3SE5, plastic and metal enclosures

Dimensional drawings

Complete units

Enclosure width 31 mm
3SE5 23.-.QV40, 3SE5 23.-.RV40

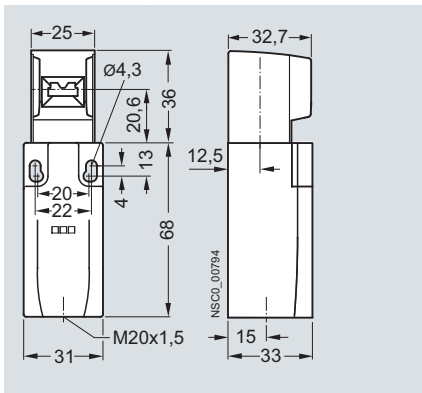

Enclosure width 50 mm
3SE5 24.-.QV40, 3SE5 24.-.RV40

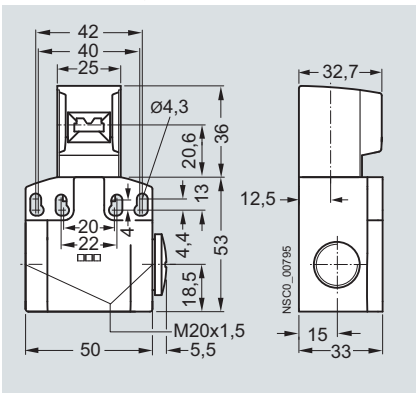

Enclosure width 40 mm
3SE5 11.-.QV10, 3SE5 11.-.RV10

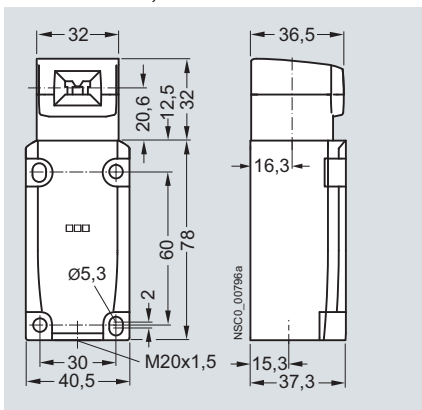

Enclosure width 56 mm
3SE5 12.-.QV10, 3SE5 12.-.RV10

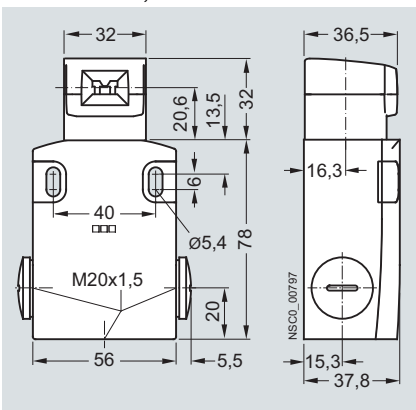

Actuators

3SE5 000-0AV01
standard actuator

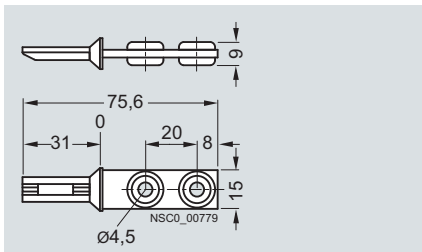

3SE5 000-0AV02
actuator with vertical fixing

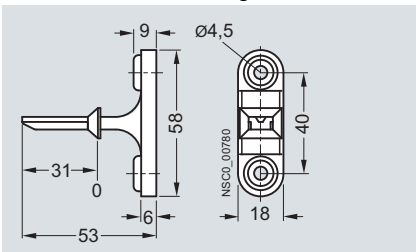

3SE5 000-0AV03
actuator with horizontal fixing

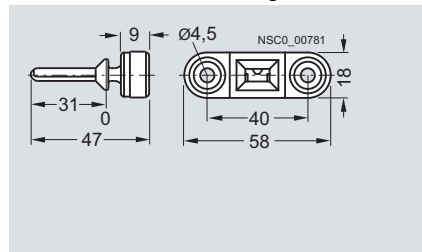

3SE5 000-0AV04
radius actuator, approach from left

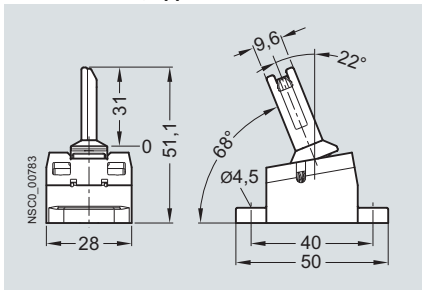

3SE5 000-0AV06
radius actuator approach from right

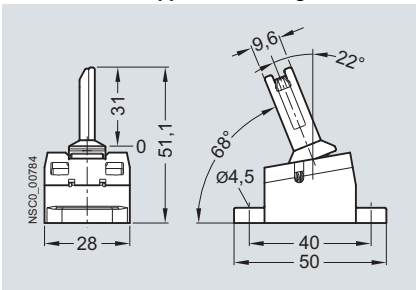

3SE5 000-0AV05
universal radius actuator

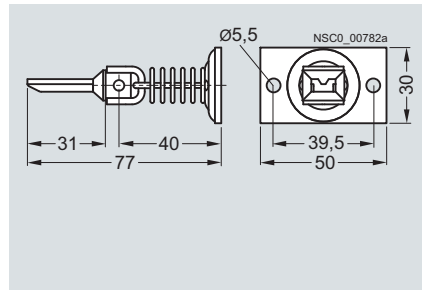

3SE5, 3SE2, 3SE3 Position Switches With Separate Actuator

3SE5, plastic and metal enclosures

3SE5 000-0AV07 universal radius actuator, heavy duty

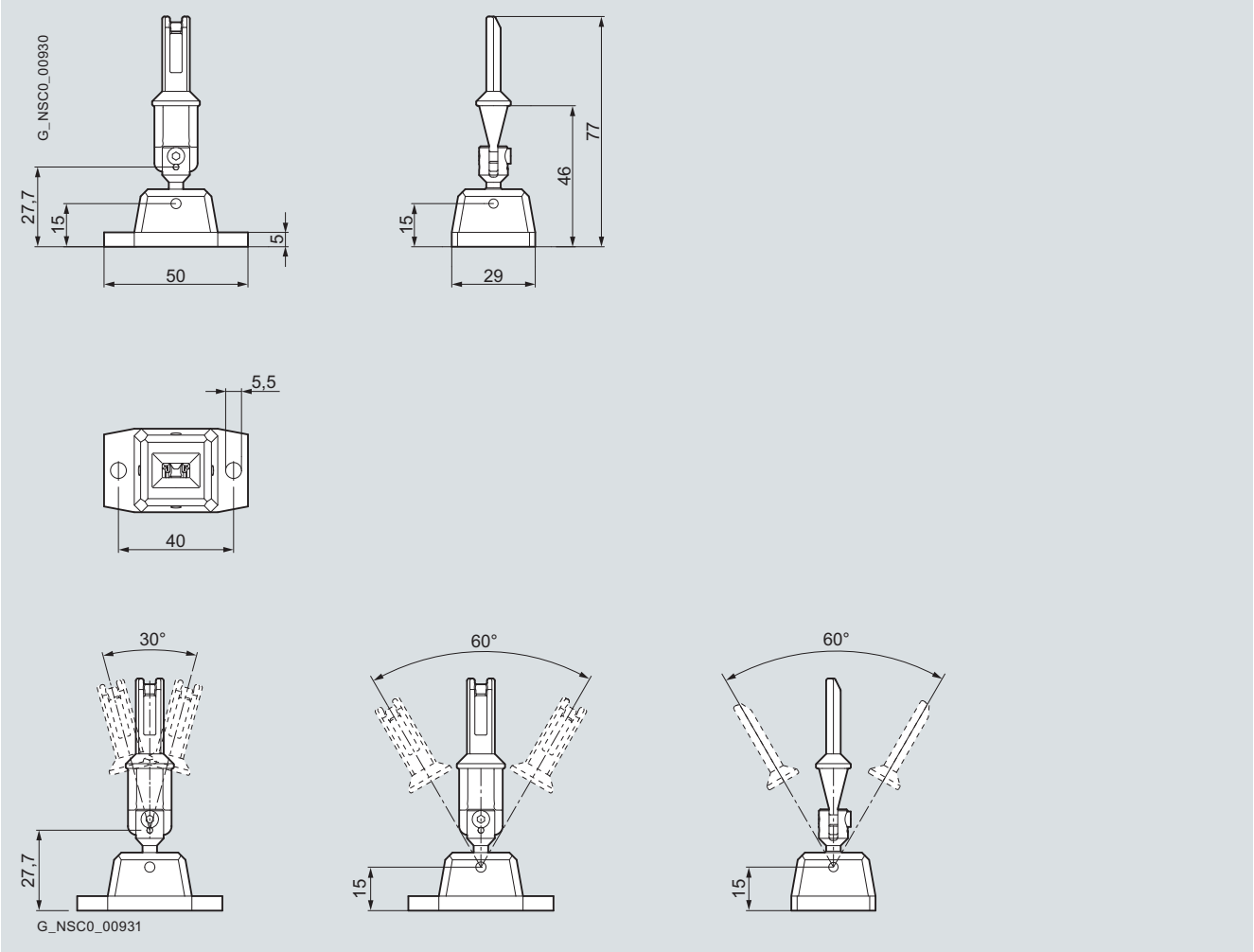

3SE5, 3SE2, 3SE3 Position Switches With Separate Actuator

3SE2, plastic enclosures

Configuration

Operation and operating travel of actuators

Operation by a separate actuator v_{max} Max. actuating speed → Direction of operation Radius actuation: for all directions of approach	Contact blocks Terminal designation acc. to EN 50013	Nominal travel  Actuator in actuator head: NC is closed	Minimum force required in operating direction on retraction
--	---	---	---

Separate actuators

Standard and radius actuators

Axial and lateral actuation

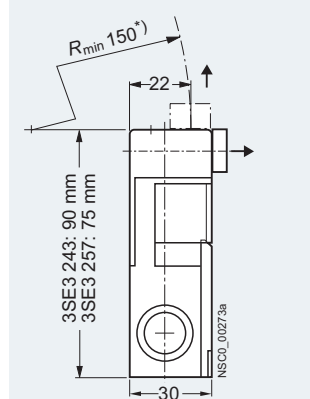

*) Radius actuator: $R_{min} > 38$ mm.

Slow-action contacts

1 NC

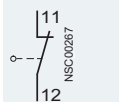

Ident. No. 01

1 NO + 2 NC

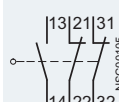

Ident. No. 12

Lateral actuation

3SE2 257-XX..

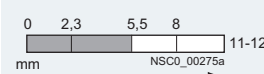

30 N
or
5 N

3SE2 243-XX..

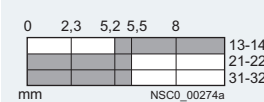

30 N
or
5 N

Dimensional drawings

3SE2 243, lateral and front-end actuation, with 3SX3 218 standard actuator

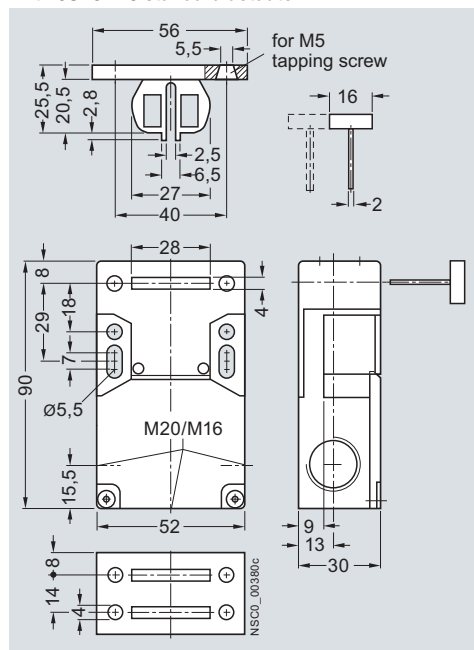

3SE2 257, lateral and front-end actuation

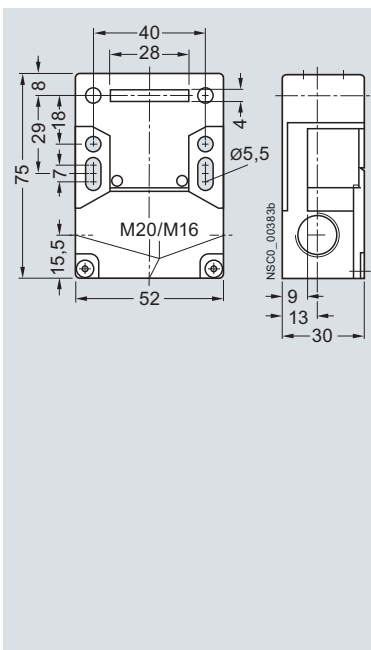

3SX3 228 universal radius actuator

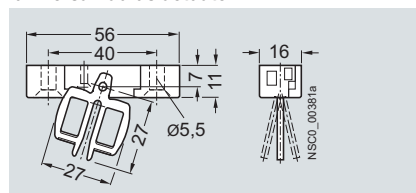

3SX3 217 actuator with ball locating

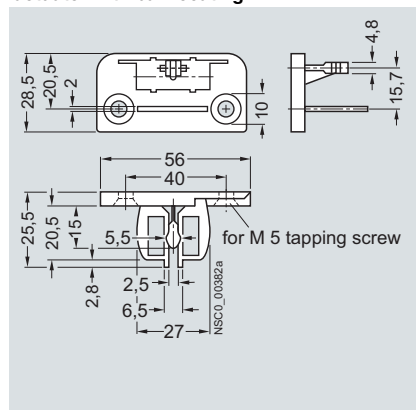

8

3SE5, 3SE2, 3SE3 Position Switches With Solenoid Interlocking

General data

Overview

The position switches with solenoid interlocking are exceptional, technically safe devices which restrict and prevent an unforeseen or intentional opening of protective doors, protective grilles or other covers as long as a dangerous situation is present (i. e. follow-on motion of the shutdown machine).



The safety position switches with solenoid interlocking are comprised of a switch part with electromechanical interlock and a mechanical actuator which has to be ordered separately.

They are rugged protective devices that enable the greatest possible safety for man and machine.

The position switches with solenoid interlocking are offered in plastic or metal enclosures.

Dimensions (W × H × D):

- 3SE5 3: 54 mm × 185 mm × 43.5 mm,
- 3SE2 8: 90 mm × 100 mm (+ head 41.3 mm) × 45 mm.

Operation

The actuator head is included in the scope of supply. For actuation from four directions it can be adjusted through 4 × 90°. The 3SE5 3 switches can also be approached from above.

The actuators are not included in the scope of supply of the position switches and must be ordered separately from a choice of six versions to suit the application.

Actuation data:

- Maximum actuating speed $v_{\max} = 1.5$ m/s
- Minimum actuating speed $v_{\min} = 0.4$ mm/s
- Minimum force in the direction of actuation $F_{\min} = 30$ N

The actuator is encoded. Simple overruling by hand or auxiliary devices is impossible.

Radius actuators

The position switches with radius actuators are particularly suitable for rotatable protective devices. The movable actuation key allows even small radii to be approached. Damage to the switch and the actuator due to inaccurate approach is prevented.

Locking devices

A high-grade steel blocking insert for attaching up to eight padlocks is available for even more safety.

Dust protection

A rubber cap to protect the actuator head from contamination is available for operation in dusty environments.

Solenoid interlocking

There are two versions for locking the actuator:

- Spring-actuated lock (closed-circuit principle) with various release mechanisms
- Magnetic field lock (open-circuit principle)

The spring-actuated switch is equipped with an auxiliary release for emergency situations or setup mode. Available as options (only 3SE5):

- Escape release or
- Emergency release

Contact blocks

The position switches with solenoid interlocking have one switching block each for:





- Monitoring the actuator or the position of the protective door
- Monitoring the position of the solenoid

The mechanical design of the switch corresponds to the requirements of the failsafe principle to EN 1088.

Optical signaling equipment

The position switches with solenoid interlocking are available with an optional optical signaling device.

The signaling device indicates the switch position of the lock and the protective device optically by means of 2 LEDs on the front.

Protective device	Solenoid interlocking	Display	Meaning
Closed	Released	 	Actuator to be pulled
Closed	Closed		Actuator locked
Open	Open		Actuator pulled

Note:

The voltage of the LEDs at the monitored contacts must be the same as the operational voltage of the magnet (same potential).

3SE5, 3SE2, 3SE3 Position Switches

With Solenoid Interlocking

General data

Technical specifications

Type		3SE5 322	3SE5 312	3SE2 83, 3SE2 84
General data				
Standards		IEC 60947-5-1, EN 60947-5-1		
Rated insulation voltage U_i	V	250		
Degree of pollution acc. to EN 60664-1		Class 3		
Rated impulse withstand voltage U_{imp}	kV	4		6
Rated operational voltage U_e				
• DC	V	24		24
• AC 50/60 Hz	V	230		110 ... 130 230
Conventional thermal current I_{th}	A	6		10
Rated operational current I_e				
• With alternating current 50/60 Hz		I_e /AC-15 or B300		I_e /AC-12 I_e /AC-15
- At 24 V	A	6		10 4
- At 120 V	A	3		10 4
- At 230 V	A	1.5		10 4
• For direct current		I_e /DC-13 or Q300		I_e /DC-12 I_e /DC-13
- At 24 V	A	3		10 3
- At 60 V		--		5 1.5
- At 110 V		--		2.5 0.7
- At 125 V	A	0.55		-- --
- At 220 V		--		1 0.3
- At 250 V	A	0.27		-- --
Magnet				
• Locking force, max.	N	1300	2600	1820
• Locking force acc. to GS-ET 19	N	1000	2000	1400
• Power consumption at U_e	W	3.5		5.2
Short-circuit protection¹⁾				
• With DIAZED fuse links, operational class gG	A	6		6
• Characteristic quick				10
• With miniature circuit breaker, Char. C	A	0.5		--
Mechanical endurance		1 × 10 ⁶ operating cycles		1 × 10 ⁶ operating cycles
Electrical endurance				
• With 3RH11, 3RT10 16 to 3RT10 26 contactors		1 × 10 ⁶ operating cycles		1 × 10 ⁶ operating cycles
• For AC-15 utilization category		1 × 10 ⁵ operating cycles, when interrupting I_e /AC-15 at 230 V		0.5 × 10 ⁶ operating cycles, when interrupting I_e /AC-15 at 230 V
• For DC-13 utilization category		With DC current the contact endurance depends not only on the breaking current but also on the voltage, the circuit inductance and the speed of switching. No generally valid information can be given.		
Switching frequency		6 × 10 ³ operating cycles/h		
With 3RH11, 3RT10 16 to 3RT10 26 contactors				
Shock resistance acc. to IEC 60068-2-27		30 g/11 ms		--

Type		3SE5 322	3SE5 312	3SE2 83, 3SE2 84
Enclosure				
Enclosure material		Ultramid A3X2G7	Zinc diecasting GD Zn Al4 Cu1	Aluminum (GD - AlSi 12)
Degree of protection acc. to EN 60529		IP66/IP67		IP67
Ambient temperature				
• During operation	°C	-25 ... +60		-30 ... +70
• During storage, transport	°C	-40 ... +80		--
Mounting position		Any		
Connection				
Cable entry		M 20 × 1.5		M 20 × 1.5
Conductor cross-sections				
• Solid	mm ²	1 × (0.5 ... 1.5)		2 × 2.5
• Finely stranded with end sleeve	mm ²	2 × (0.5 ... 0.75)		2 × 1.5
Protective conductor connection		--		M3.5
Inside enclosure				

¹⁾ Without any welds according to IEC 60947-5-1.

3SE5, 3SE2, 3SE3 Position Switches With Solenoid Interlocking

3SE5, plastic and metal enclosures

Schematics

3SE5

Monitoring the actuator:

Slow-action contacts 1 NO + 2 NC

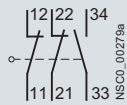

Monitoring the solenoid:

Slow-action contacts 1 NO + 2 NC

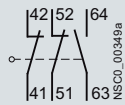

Configuration

Operation and operating travel of actuators

Operation by a separate actuator

- ⊕ Positive opening acc. to EN 60947-5-1
- V_{max} Max. actuating speed
- Direction of operation

Contact blocks

Terminal designation acc. to EN 50013

Nominal travel

- Contact closed
- Contact open
- Actuator in actuator head: NC is closed

Separate actuators with solenoid interlocking

Standard actuators

Axial and lateral actuation ($4 \times 90^\circ$)

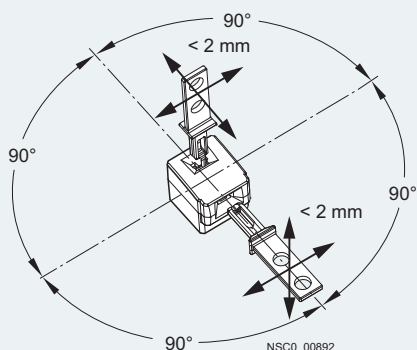

Minimum force required in operating direction 30 N (on retraction)

Radius actuators (all directions of approach)

Example: Direction of approach from the left

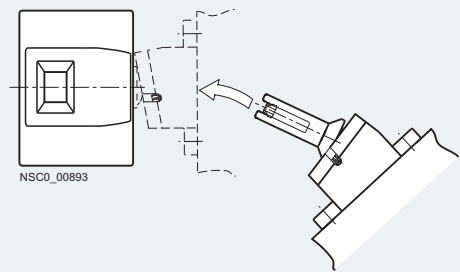

Slow-action contacts

1 NO + 2 NC

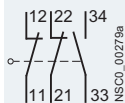

Ident. No. 12

Lateral actuation

3SE5 3...-S...

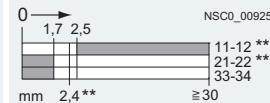

Axial actuation

3SE5 3...-S...

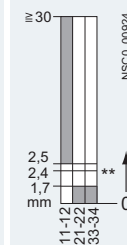

3SE5, 3SE2, 3SE3 Position Switches

With Solenoid Interlocking

3SE5, plastic and metal enclosures

Dimensional drawings

Spring-actuated lock, with auxiliary release
 3SE5 322-.SD2., 3SE5 322-.SG2., 3SE5 322-.SJ2.,
 3SE5 312-.SD1., 3SE5 312-.SG1., 3SE5 312-.SJ1.,

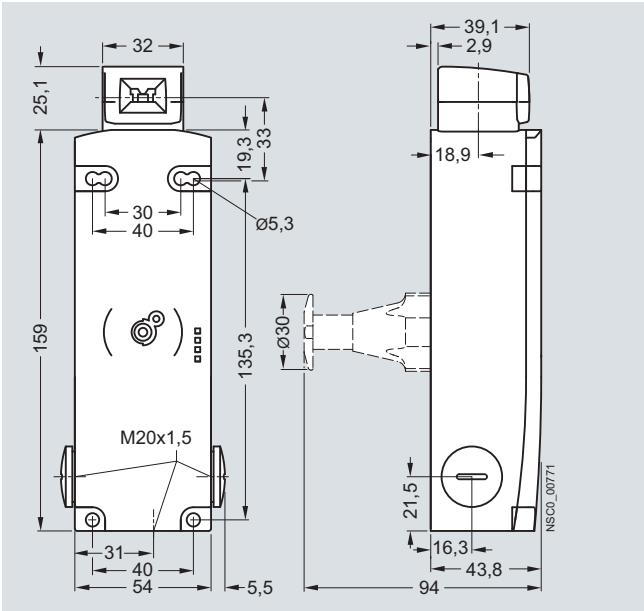

Spring-actuated lock, with auxiliary release with lock
 3SE5 322-.SE2.,
 3SE5 312-.SE1.

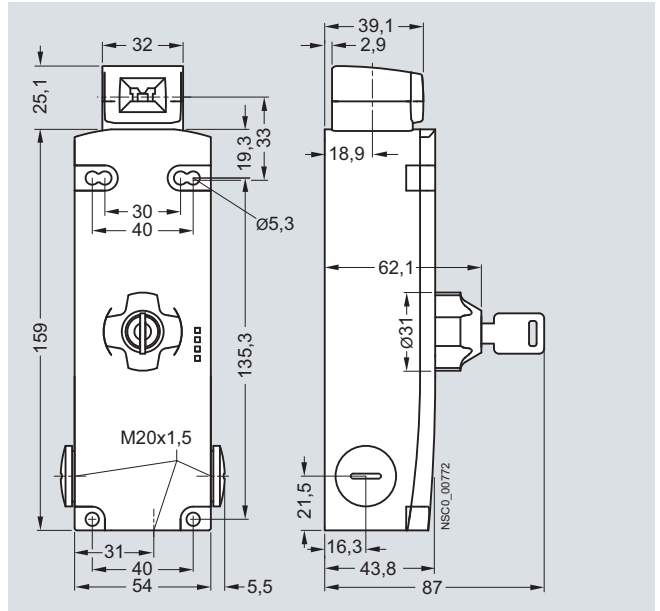

Spring-actuated lock, with escape release
 3SE5 322-.SF2.,
 3SE5 312-.SF1.

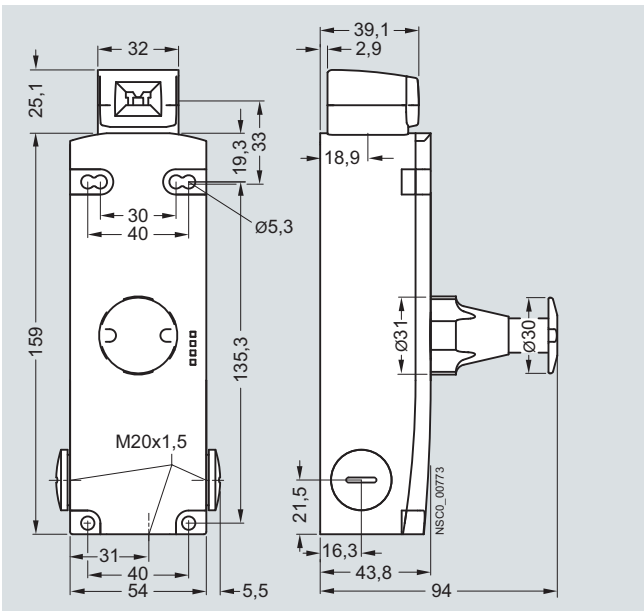

Magnetic field lock
 3SE5 322-.SB2.,
 3SE5 312-.SB1.

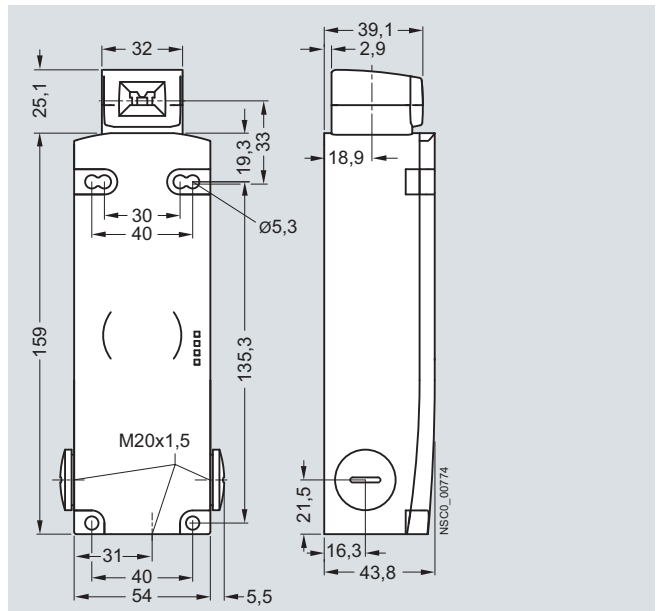

The plastic enclosures have knock-out openings behind the connecting thread; they are delivered therefore without protective caps.

For actuators see page 8/44.

3SE5, 3SE2, 3SE3 Position Switches With Solenoid Interlocking

3SE2, metal enclosures

Configuration

Operation, actuating speed and travel of actuators

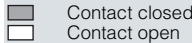
Operation by a separate actuator v_{max} Max. actuating speed \rightarrow Direction of operation	Contact blocks Terminal designation acc. to EN 50013	Nominal travel  Contact closed Contact open Actuator in actuator head; NC is closed	Minimum force required in operating direction on retraction
---	--	---	---

Separate actuators with solenoid interlocking

Standard and radius actuators

Lateral actuation ($4 \times 90^\circ$)

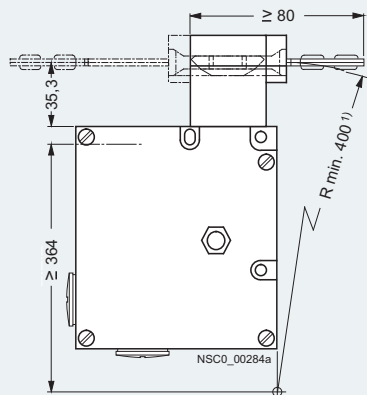

$v_{max} = 1.5 \text{ m/s}$

- 1) Universal radius actuator: $R_{min} > 70 \text{ mm}$.
- 2) Destruction of internal parts will result if this value is exceeded.

Slow-action contacts

1 NO + 1 NC

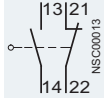

Ident. No. 11

2 NC

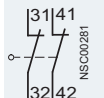

Ident. No. 02

Lateral actuation

3SE2 8..-0XX.., 3SE2 8..-1XX..

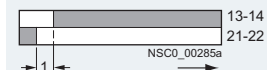

10 N
 Locking force:
 max. 1820 N,
 duration 5 s²⁾

3SE2 8..-6XX..

Dimensional drawings

3SE2 83.-XX, 3SE2 84.-XX
metal enclosure, lateral actuation

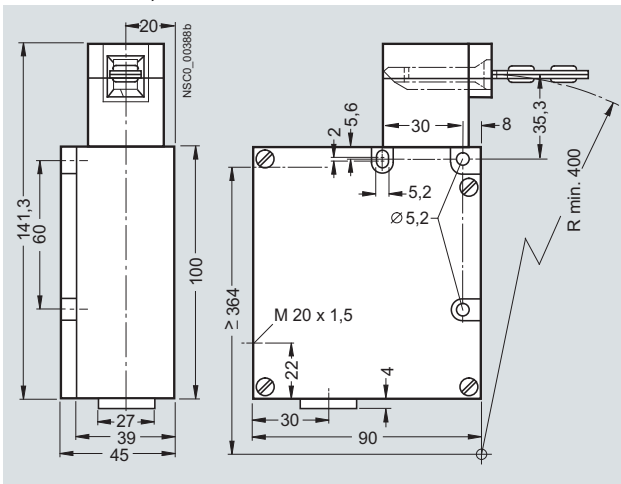

3SX3 203
universal radius actuator

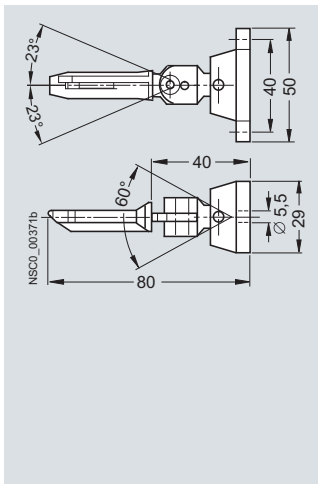

3SX3 206 standard actuator
for transverse fixing

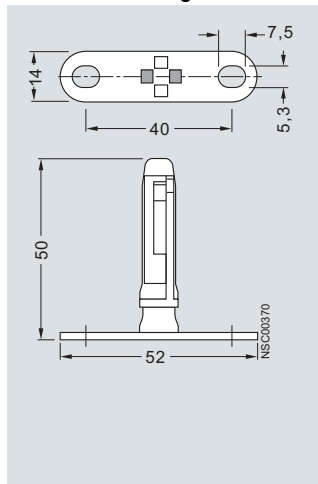

3SX3 207 actuator
for direction of approach from the left side

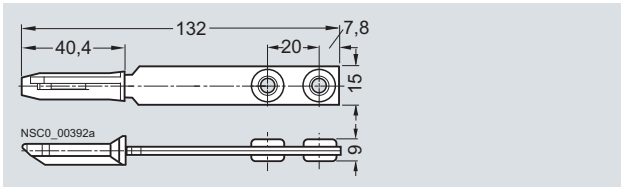

3SX3 197 standard actuator
for lengthwise fixing

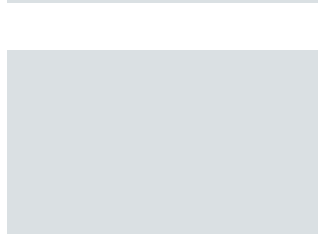
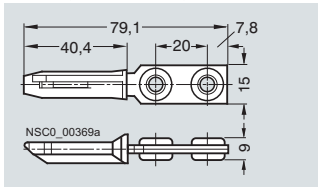

3SE5, 3SE2, 3SE3 Position Switches

Hinge Switches

General data

Overview

The hinge switches are used in those areas where the position of swivelable protective devices such as doors or flaps must be monitored. The position of the doors and hinge switches is converted into electric signals with the switches. The switches allows shutdown and signaling without delay in the event of a small opening angle through the snap-action contacts with an operating angle of 10°.

3SE5 hinge switches have the same enclosures as the standard switches (modular system).



Hinge switches

Design

Enclosure sizes

The 3SE5 switches are available as complete units in two enclosure sizes:

- Plastic enclosures according to EN 50047 (31 mm wide), 1 cable entry
- Metal enclosures according to EN 50041 (40 mm wide), 1 cable entry

Enclosure versions

Various basic versions can be selected for the enclosures:

- Available with two or three-pole switching elements designed as snap-action contacts
- Metal enclosures for explosion protection (ATEX) ([see page 8/55](#))
- AS-Interface version with integrated ASIsafe electronics for all enclosure designs ([see page 8/56](#))

[For a description of the basic switches see page 8/4.](#)

Operating mechanism

The hinge switches are provided for mounting on hinges. The actuator head is included in the scope of supply. There are two versions:

- Operating mechanism with hollow shaft, diameter inside 8 mm, outside 12 mm
- Operating mechanism with solid shaft, diameter 10 mm

3SE5, 3SE2, 3SE3 Position Switches Hinge Switches

3SE5, plastic and metal enclosures

Configuration

Contact blocks and operating travel of actuators

Contact blocks	Nominal travel	Contact blocks	Nominal travel
Terminal designation acc. to EN 50013	 Contact closed Contact open	Terminal designation acc. to EN 50013	
Hinge switches		Snap-action contacts	
1 NO + 1 NC Ident. No. 11	3SE5 ...-0HU2. NSCO_00918 13-14 21-22 **	1 NO + 2 NC Ident. No. 12	3SE5 ...-0LU2. NSCO_00919 13-14 21-22 ** 31-32 **

Dimensional drawings

Enclosure width 31 mm
with hollow shaft
3SE5 232-0.U21

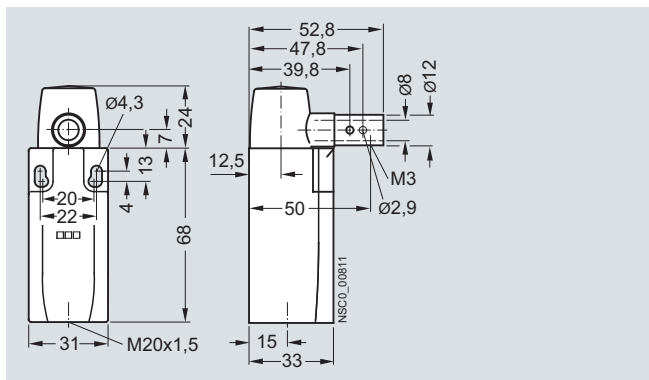

Enclosure width 31 mm
with solid shaft
3SE5 232-0.U22

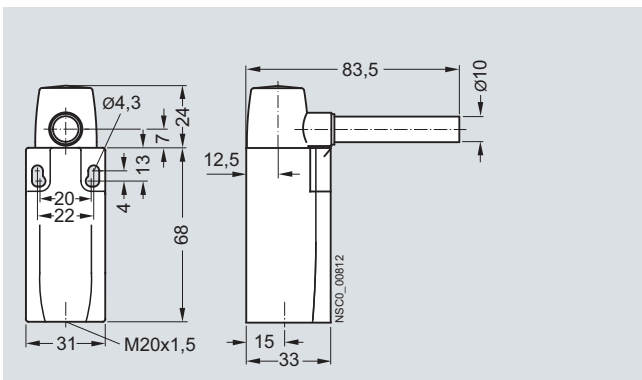

Enclosure width 40 mm
with hollow shaft
3SE5 112-0.U21

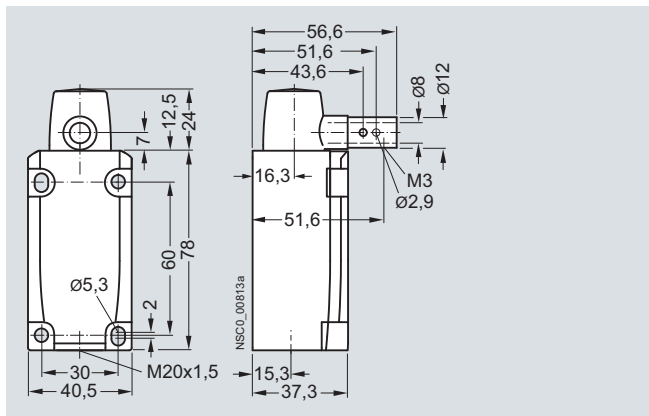

Enclosure width 40 mm
with solid shaft
3SE5 122-0.U22

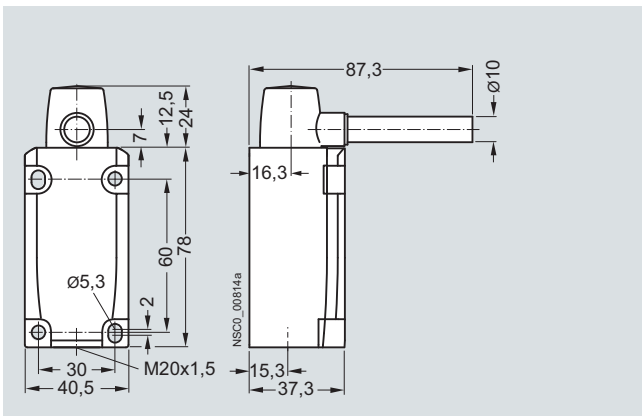

3SE5, 3SE2, 3SE3 Position Switches

Hinge Switches

3SE2, plastic enclosures With integrated hinge

Overview

The hinge switches are used for monitoring and protecting hinged protective devices such as doors and flaps.

Characteristics

- Special design, with 2 × M20 × 1.5 connecting thread
- Degree of protection IP65
- 3 contacts
- Operating angle of 4° or 8°

Design

The 3SE2 283 hinge switch has an integrated electromechanical contact block that is actuated when the hinged protective cover is opened. If the cover is opened by 4° or 8°, the NC contact is positively opened by a direct (not spring-action) mechanism. These positively driven contacts guarantee interruption of the electric circuit and stopping of the machine. The NO contact is closed when the cover is moved by 13.5°.

Technical specifications

Type	3SE2 283	
Rated insulation voltage U_i	V	250
Conventional thermal current I_{th}	A	2.5
Rated operational current I_e		
• At AC-15, 120 V	A	4.2
• At AC-15, 250 V	A	2
• At DC-13, 24 V	A	1
Min. make-break capacity	> 5 V/1 mA	
Short-circuit protection		
• Operational class gG	A	2
Mechanical endurance	> 1 × 10 ⁶ operating cycles	
Switching frequency	1200 operating cycles/hour	
Positive opening	2 mm after opening point	
Enclosure material	Plastic	
Degree of protection	IP65	
Ambient temperature	°C	-25 ... +65
Shock resistance	30 g/18 ms	
Resistance to vibrations	20 g/10 ... 200 Hz	
Cable entry	2 × (M20 × 1.5)	
Screw terminals	0.5 ... 1.5 mm ² /AWG 15	

Configuration

Contact blocks and operating travel of actuators (operating angle 4°)

Contact blocks	Nominal travel	Contact blocks	Nominal travel
Terminal designation acc. to EN 50013		Terminal designation acc. to EN 50013	
Hinge switches		Slow-action contacts	
1 NO + 2 NC	3SE2 283-0GA4.	3 NC	3SE2 283-6GA4.
Ident. No. 12		Ident. No. 03	

Dimensional drawings

3SE2 283-GA.3 hinge switch with hinge

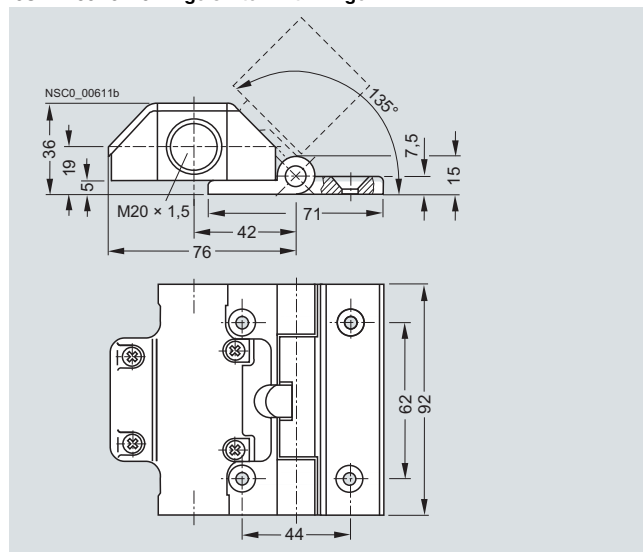

3SX3 225 additional hinge

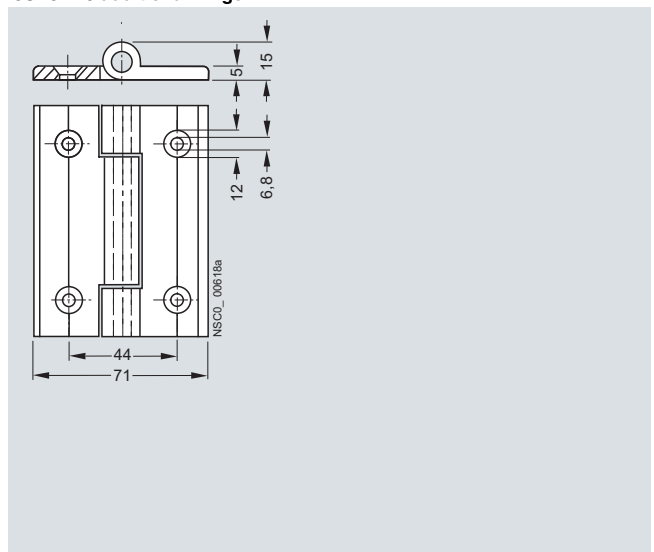

3SE5, 3SE2, 3SE3 Position Switches For Explosion Protection (ATEX)

3SE5, metal enclosures

Overview



The position switch in the metal enclosure including the hinge switch and the switch with a separate actuator is also available in versions for operation in areas with a gas explosion hazard and in areas with combustible dust.

To achieve the maximum possible safety in these areas, the legislators of most countries have drawn up requirements in the form of laws, regulations and standards which these switches comply with to the letter.

These switches comply with Directive 94/4/EC (ATEX 95) of the European Union and are approved for Zone 22.

The switches have a grounding screw on the outside of the enclosure. The connection openings are closed with protective caps upon delivery.

See Chapter 20 "Appendix" --> "Standards and approvals" --> "Type overview of approved devices for potentially explosive areas (ATEX explosion protection)".

Dimensional drawings

**Enclosure width 40 mm, EN 50041, ATEX,
with M20 x 1.5 connecting thread
3SE5 112**

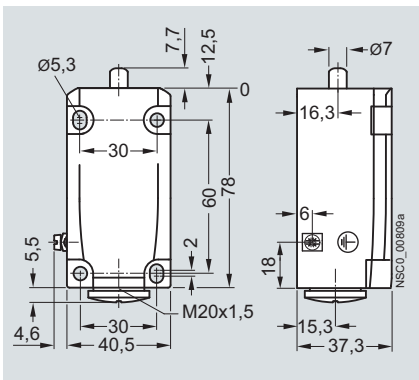

**Enclosure width 56 mm, ATEX,
with M20 x 1.5 connecting thread
3SE5 122**

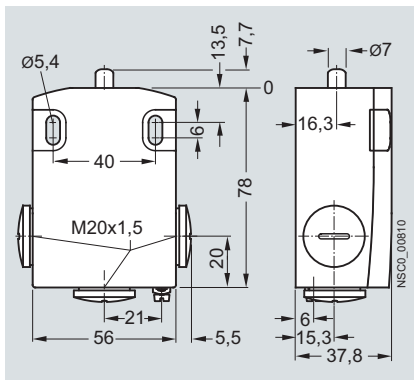

For dimensional drawings of the operating mechanisms, see pages 8/18 and 8/19.

For actuation, see pages 8/14 to 8/16.

3SF1 AS-Interface Position Switches

General data

Overview

The 3SF1 position switches with safety-oriented communication can be directly connected using the AS-Interface bus system. The safety functions no longer have to be conventionally wired up.

With the 3SF1 position switches the ASIsafe electronics are integrated in the switch enclosure.



Examples of selection options in the modular system

Modular system

The position switches of the 3SF1 1.4 and 3SF1 2.4 series are constructed from a modular system comprising different versions of the basic enclosure and an actuator which must be ordered separately. Thanks to the modular design of the switch the end user can select the right solution for his application from numerous versions and install it himself in a very short time.

Display

The switches have a status display with three LEDs:

- LED 1 (yellow): F-IN1
- LED 2 (yellow): F-IN2
- LED 3 (green/red): AS-i/FAULT

Connection

Connection to the AS-Interface is by means of a 4-pole M12 connector socket (plastic version) connected to the yellow AS-Interface bus cable.

The wide enclosures (50 or 56 mm) also have an M12 socket for connecting a second position switch. Category 4 according to EN 954-1 is thus achieved.

Technical specifications

Type	3SF1 1.., 3SF1 2..	
General data		
Standards	IEC 60947-5-1, EN 60947-5-1, EN 1088	
Acc. to AS-Interface specification		
• I/O configuration		0/B
• ID1 code/ID2 code (Hex)		F/F
• Power consumption, overall	mA	≤ 60
Inputs		
• Low signal range		Contact open
• High signal range		Contact closed, I_{in} dynamic ($I_{peak} \geq 5$ mA)
Status display		
Green/red dual LED		
Rated impulse withstand voltage U_{imp}	kV	0.6
EMC resistance		
• EN 60000-1-2	kV	4
• EN 60000-4-3	V/m	10
• EN 60000-4-4 (A/B)	kV	1/2
Mechanical endurance		
• Basic switches		15×10^6 operating cycles
• With spring rod, 3SF1 ...-R..		10×10^6 operating cycles
• With fork lever, 3SF1 1...-T..		1×10^6 operating cycles
• With separate actuator, 3SF1 ...-V..		1×10^6 operating cycles
PFH value		
Probability of failure upon request of the safety function, with 1 actuation per hour and $B10 = 5 \times 10^6$		
• Basic switches		4×10^{-9} 1/h
• With separate actuator, 3SF1 ...-V..		2×10^{-9} 1/h
• Hinge switch, 3SF1 ...-U..		2×10^{-9} 1/h
Shock resistance acc. to IEC 60068-2-27		30 g/11 ms

Type	3SF1 23.	3SF1 24.	3SF1 11.	3SF1 12.
Enclosure				
Enclosure				
• Material	Ultramid A3X2G7		Zinc diecasting GD Zn Al4 Cu1	
• Width	mm 31	50	40	56
• Dimensions acc. to EN	EN 50047	--	EN 50041	--
Degree of protection acc. to EN 60529	IP65	IP66/IP67 ¹⁾		
Ambient temperature				
• During operation	°C	-25 ... +60		
• Storage, transport	°C	-40 ... +80		
Mounting position	Any			

¹⁾ For twist actuators with spring rod and rod actuators: IP65/IP67.

Connector assignment

M12 connector socket, 4-pole

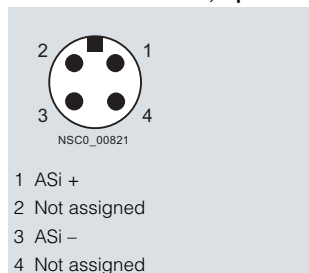

M12 socket, 4-pole

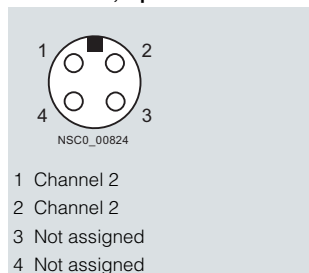

LEDs

Status display (operating state)

LEDs	No voltage on AS-Interface chip	Communication OK	Communication failed	Slave has address "0"
ASI/Fault (GN/RD)				

Safe inputs

LEDs	Not actuated	Actuated
F-IN1 (YE)		
F-IN2 (YE)		

3SF1 AS-Interface Position Switches

Plastic and metal enclosures

Dimensional drawings

Basic switches (without actuator)

Enclosure width 31 mm, EN 50047
3SF1 234

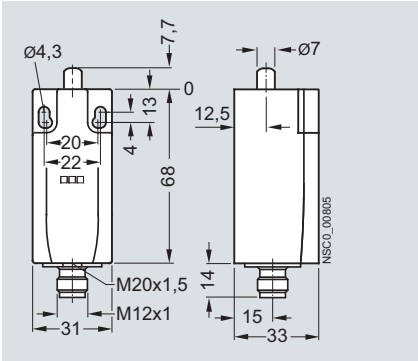

Enclosure width 50 mm
3SF1 244

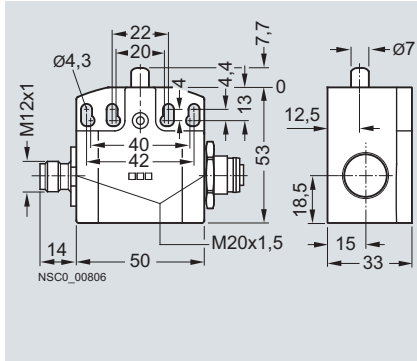

Enclosure width 40 mm, EN 50041
3SF1 114

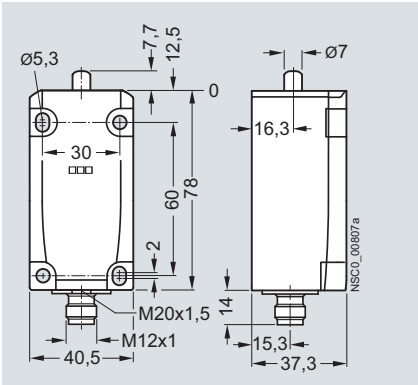

Enclosure width 56 mm
3SF1 124

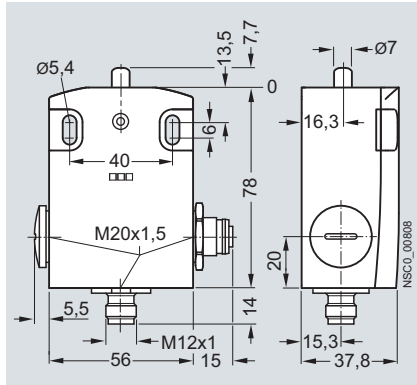

For operating mechanisms, see pages 8/18 and 8/19.

For actuation, see pages 8/18 to 8/16.

For hinge switches see page 8/52.

3SF1 AS-Interface Position Switches

With Separate Actuator

General data

Overview

The 3SF1 position switches with safety-oriented communication can be directly connected using the AS-Interface bus system. The safety functions no longer have to be conventionally wired up.

With the 3SF1 position switches the ASIsafe electronics are integrated in the switch enclosure.



3SF1 position switches with separate actuator and with integrated ASIsafe Electronics

3SF1 position switches with separate actuator have the same enclosures as the standard switches.

Operation

The actuator head is included in the scope of supply. For actuation from four directions it can be adjusted through 4 x 90°. The switches can also be approached from above.

The actuators are not included in the scope of supply of the position switch and must be ordered separately from a choice of six versions to suit the application.

The actuator is encoded. Simple overruling by hand or auxiliary devices is impossible.

A high-grade steel blocking insert for attaching up to eight padlocks is available for even more safety.

A rubber cap to protect the actuator head from contamination is available for operation in dusty environments.

Display

The switches have a status display with three LEDs:

- LED 1 (yellow): F-IN1
- LED 2 (yellow): F-IN2
- LED 3 (green/red): AS-i/FAULT

Connection

Connection to the AS-Interface is by means of a 4-pole M12 connector socket (plastic version) connected to the yellow AS-Interface bus cable.

The wide enclosures (50 or 56 mm) also have an M12 socket for connecting a second position switch. Category 4 according to EN 954-1 is thus achieved.

3SF1 AS-Interface Position Switches With Separate Actuator

Plastic and metal enclosures

Dimensional drawings

Enclosure width 31 mm, EN 50047
3SF1 234-..V..

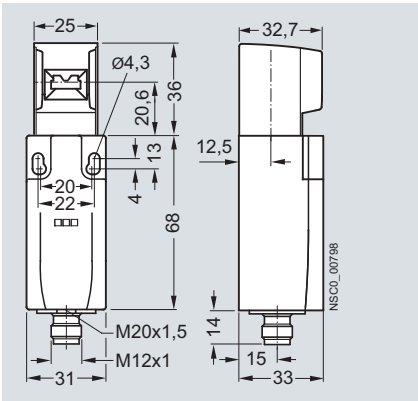

Enclosure width 50 mm
3SF1 244-..V..

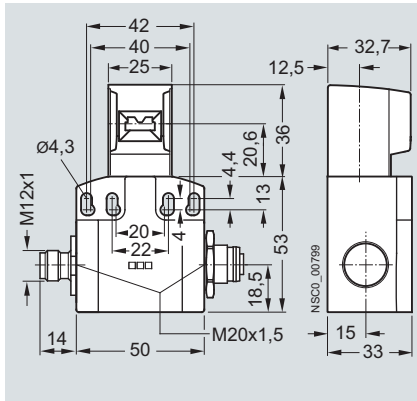

Enclosure width 40 mm, EN 50041
3SF1 114-..V..

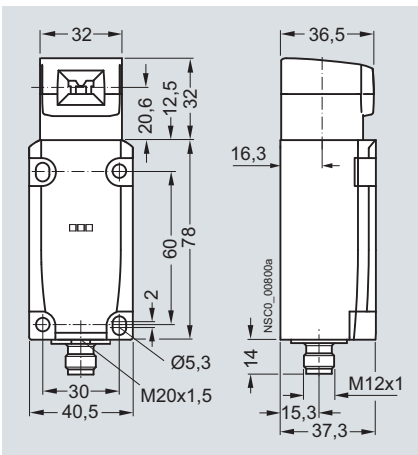

Enclosure width 56 mm
3SF1 124-..V..

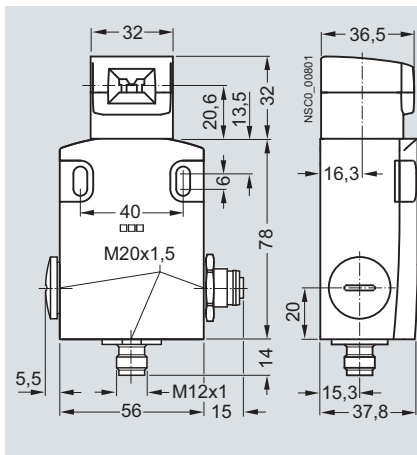

For actuators see page 8/44.

3SF1 AS-Interface Position Switches With Solenoid Interlocking

General data

Overview

The position switches with solenoid interlocking are exceptional, technically safe devices which restrict and prevent an unforeseen or intentional opening of protective doors, protective grilles or other covers as long as a dangerous situation is present (i. e. follow-on motion of the shutdown machine).

The 3SF1 position switches with safety-oriented communication can be directly connected using the AS-Interface bus system. The safety functions no longer have to be conventionally wired up.

With the 3SF1 position switches the ASIsafe electronics are integrated in the switch enclosure.



3SF1 position switch with solenoid interlocking and with integrated ASIsafe electronics

Operation

The actuator head is included in the scope of supply. For actuation from four directions it can be adjusted through 4 x 90°. The switches can also be approached from above.

The actuators are not included in the scope of supply of the position switch and must be ordered separately from a choice of six versions to suit the application.

The actuator is encoded. Simple overruling by hand or auxiliary devices is impossible.

A high-grade steel blocking insert for attaching up to eight padlocks is available for even more safety.

A rubber cap to protect the actuator head from contamination is available for operation in dusty environments.

Solenoid interlocking

There are two versions for locking the actuator:

- Spring-actuated lock (closed-circuit principle) with various release mechanisms
- Magnetic field lock (open-circuit principle)

Display

The switches have a status display with four LEDs:

- LED 1 (green): AS-i
- LED 2 (red): FAULT
- LED 3 (yellow): F-IN1
- LED 4 (yellow): F-IN2

Connection

Connection to the AS-Interface is by means of a 4-pole M12 connector socket (plastic version) connected to the yellow AS-Interface bus cable (an additional supply of auxiliary power is not required thanks to the low current consumption of the magnet of max. 170 mA).

3SF1 AS-Interface Position Switches With Solenoid Interlocking

Plastic and metal enclosures

Dimensional drawings

Spring-actuated lock, with auxiliary release
3SF1 324-.SD1., 3SF1 324-.SG1., 3SE5 324-.SJ1.,
3SF1 314-.SD1., 3SF1 314-.SG1., 3SE5 314-.SJ1.,

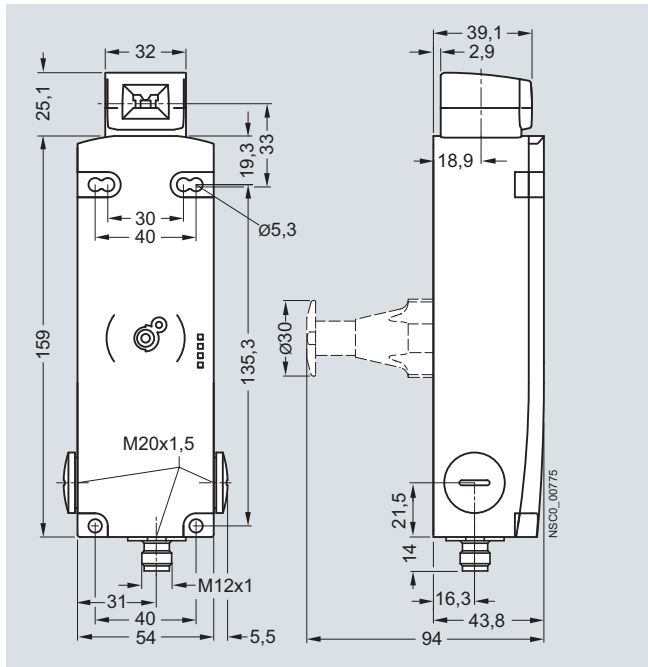

Spring-actuated lock, with auxiliary release with lock
3SF1 324-.SE1.,
3SF1 314-.SE1.

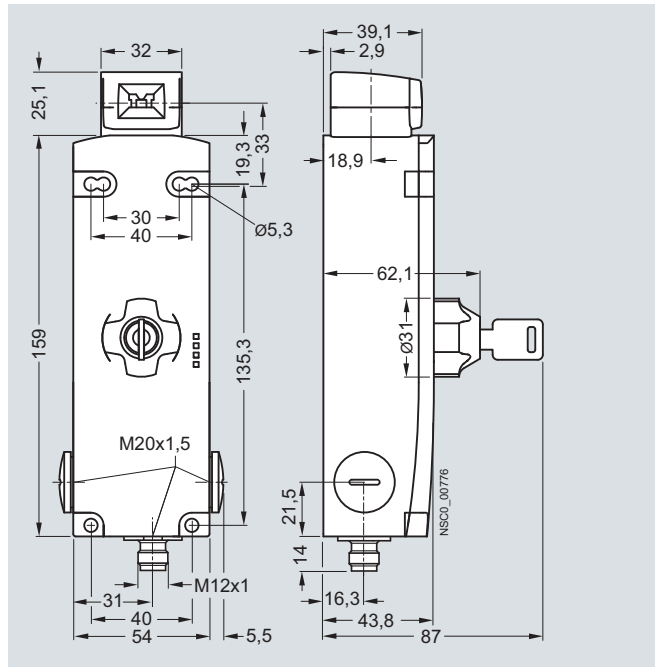

Spring-actuated lock, with escape release
3SF1 324-.SF1.,
3SF1 314-.SF1.

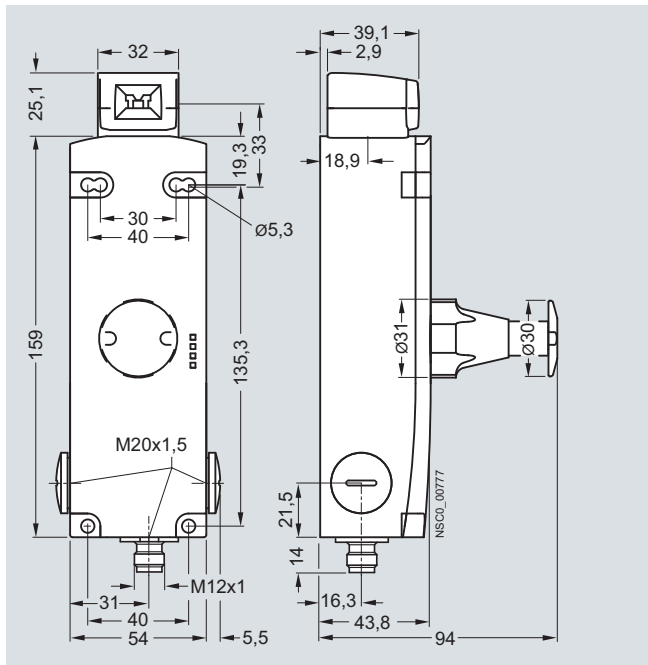

Magnetic field lock
3SF1 324-.SB1.,
3SF1 314-.SB1.

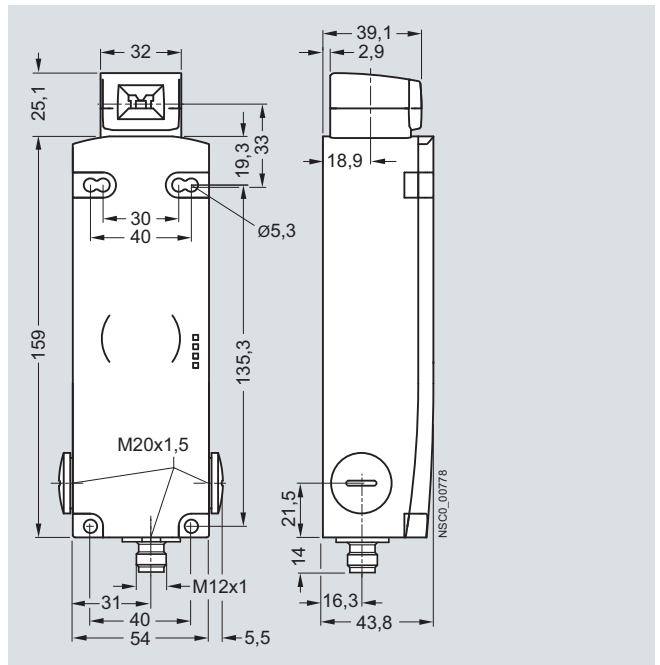

The plastic enclosures have knock-out openings behind the lateral connecting thread; they are delivered therefore without protective caps.

For actuators see page 8/44.

Overview



A magnetically operated switch is comprised of a coded switching magnet and a switching element (sensor unit). Evaluation requires a safety relay or connection to a bus system.

Design

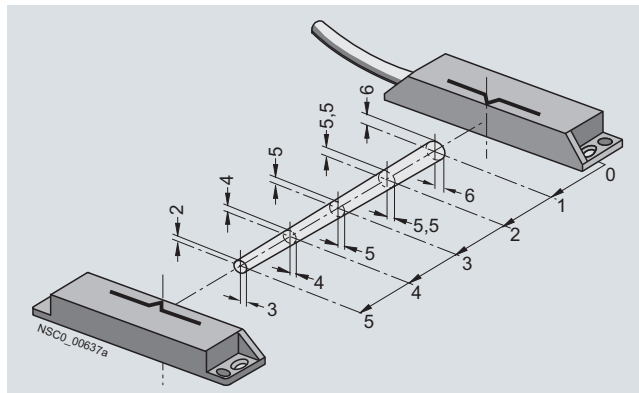

Enabling range (example)

A magnetic monitoring system is comprised of a coded switching magnet, a contact block (sensor unit) and a monitoring device (see Function).

The contact block and switching magnet must not be installed on ferromagnetic materials because the switching response will be influenced. Spacers can be used to prevent this.

The contact blocks are available with either a connecting cable or connector.

Function

3SE6 806 safety relay

The 3SE6 806 safety relay has two floating enabling circuits (safe circuits) as NO contact circuits and one floating signaling circuit as a NC circuit. The number of enabling circuits can be increased by adding one or more 3TK28 30 expansion modules.

Up to six protective devices (sensors) can be connected to the safety relay. The device has six current-sourcing semiconductor outputs (Y1 ... Y6), which report the state of the connected protective devices.

Crossovers between the sensor circuits as well as ground faults and open circuits are detected by an internal monitor. The device is protected by an internal self-restoring PTC fuse (multifuse).

The green LED indicates the operating state:

- LED POWER on: Supply voltage available
- LED CHA 1 on: All NO contacts of the connected sensors are open
- LED CHA 2 on: All NC contacts of the connected sensors are closed

Combination of monitoring units and magnetically operated switches

Monitoring units	Magnetically operated switches (switching element + switching magnet)				Achievable category (EN 954-1)/ Performance level (EN ISO 13849-1)	
	1 NC + 1 NO	2 NC	3 NC	4 NC		
	3SE6 605-1BA	3SE6 605-2BA	3SE6 605-3BA	3SE6 604-2BA		
	3SE6 704-1BA	3SE6 704-2BA	3SE6 704-3BA	3SE6 704-2BA		
Relay outputs						
SIRIUS safety relays, 6-fold	3SE6 806-2CD00	✓	✓	✓	–	Cat. 3
SIRIUS safety relays	3TK28 26	✓	✓	✓	✓	Cat. 4/e
Solid-state outputs						
SIRIUS safety relays	3TK28 40	–	–	–	✓	Cat. 3/d
	3TK28 41, 3TK28 42, 3TK28 45	–	–	–	✓	Cat. 4/e
SIRIUS safety relays with contactor relay	3TK28 50, 3TK28 51, 3TK28 52	–	–	–	✓	Cat. 3/d
	3TK28 53	–	–	–	✓	Cat. 4/e
SIRIUS safe load feeders	3RA71 0.	–	–	–	✓	Cat. 3
	3RA71 1.	–	–	–	✓	Cat. 4
ASIsafe compact safety modules	3RK1 205, 3RK1 405	–	–	–	✓	Cat. 4
SIMATIC S7-31xF-2 DP or SIMATIC ET 200M	SM 326 F, 24 DI, DC 24 V, SM 326 F, 8 DI, NAMUR	✓	✓	✓	✓	Cat. 4
SIMATIC ET 200S PROFIsafe	4/8 F-DI / 3 F-DO, 24 V DC	✓	✓	✓	✓	Cat. 3
	4/8 F-DI, 24 V DC	✓	✓	✓	✓	Cat. 4
SIMATIC ET 200eco	4/8 F-DI, 24 V DC	✓	✓	✓	✓	Cat. 4
SIMATIC ET 200pro	8/16 F-DI, 24 V DC, 4/8 F-DI / 4 F-DO 2 A, 24 V DC, F-Switch	✓	✓	✓	✓	Cat. 4

3SE6 Magnetically Operated Switches

Magnetic monitoring systems

Technical specifications

Contact blocks (sensors)				
Type		3SE6 60.- 1BA	3SE6 60.- 2BA	3SE6 60.- 3BA
Design		M30	25 mm × 88 mm	25 mm × 33 mm
Standards		EN 60947-5-3 (in combination with monitoring unit or AS-Interface)		
Mode of operation		Magnetic		
Operational voltage	V	100 AC/DC	120 AC/DC	24 DC
Operational current	mA	400 mA		100 mA
Rating				
• AC	VA	10		--
• DC	W	10		1
Max. switching frequency	Hz	5		
Max. switching interval $S_{on} \dots S_{off}$	mm	5 ... 15		4 ... 14
Enclosure				
Enclosure material		Fiber-glass strengthened thermoplast		
Degree of protection Acc. to EN 60529		IP67		
Ambient temperature				
• During operation	°C	-25 ... +70		
• During storage, transport	°C	-25 ... +70		
Shock resistance		10 g/11 ms		
Vibration resistance		10 ... 55 Hz, amplitude 1 mm		
Connection				
• Line		LiYY 4 × 0,25 mm, length 3 m		
• Connector socket		M12	M8	--
Max. cable length (for connection to safety relay)	m	1000		100

Safety relay		
Type		3SE6 806-2CD00
Standards		EN ISO 13849-1, EN 1088
Rated control supply voltage U_s	V	24 DC
Operating range		0.85 ... 1.2 × U_s
Rated power (without signaling circuits Y1 ... Y6)	W	3
Inputs		6 sensors (1 NO or 1 NC)
Outputs		6 signaling outputs, 1 relay output, 2 enabling circuits
Response time		
• Automatic start	ms	Typ. 150
• Manual start	ms	Typ. 25
Release time	ms	Max. 20
Recovery time	ms	350
Signaling circuits		
Max. load current		
• Signaling circuit Y1 ... Y6	mA	20
• Signaling circuit 31, 32	A	2
Enabling circuits		
Switching capacity		
Enabling circuits 13, 14, and 23, 24		
Conventional thermal current I_{th}	A	6
Rated operational current I_e at rated operational voltage U_e		
• AC-15 at 230 V	A	6 A
• DC-13		
- At 24 V	A	6
- At 115 V	A	0.2
- At 230 V	A	0.1
Short-circuit protection For enabling circuits		
DIAZED fuse links		
• gL (gG) operational class	A	6
• Quick	A	10
Enclosure		
Degree of protection Acc. to EN 60529		IP20
Ambient temperature		
• During operation	°C	-25 ... +45
• During storage, transport	°C	-25 ... +70
Connection		Screw terminals

Dimensional drawings

Round magnetically operated switch

3SE6 605-1BA switching element

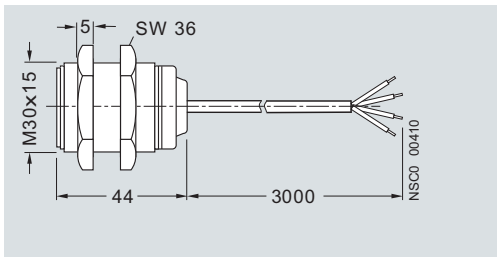

3SE6 605-1BA02 switching element

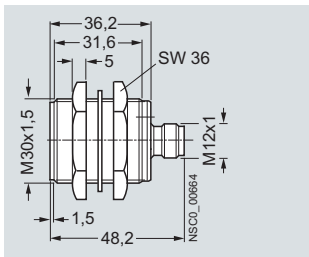

3SE6 704-1BA switching magnet element

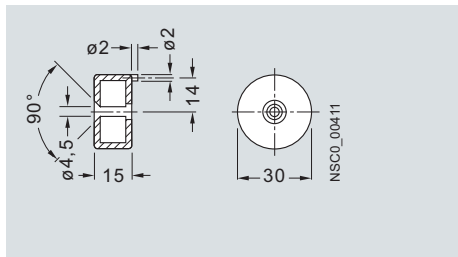

Square magnetically operated switch

3SE6 60.-2BA switching element

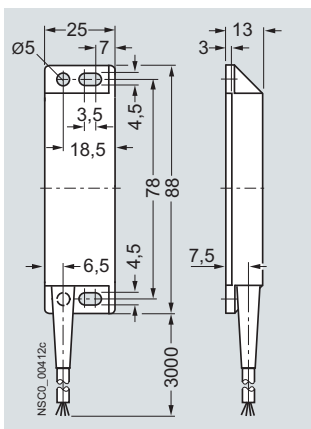

3SE6 60.-2BA01 switching element

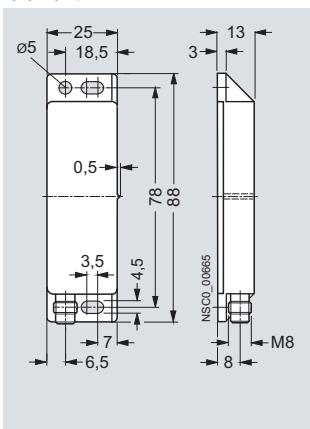

3SE6 704-2BA switching magnet element

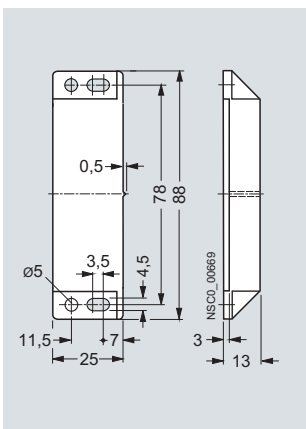

3SX3 260 spacer

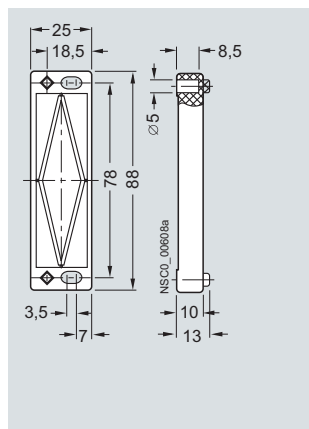

3SE6 605-3BA switching element

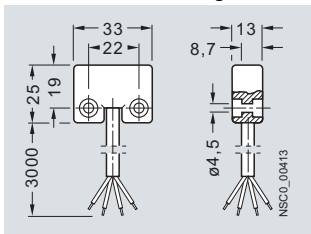

3SE6 704-3BA switching magnet

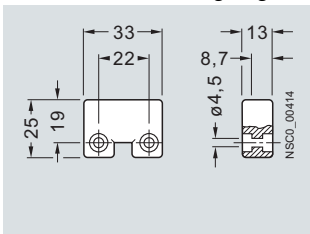

3SX3 261 spacer

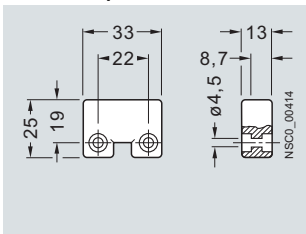

Evaluation unit

3SE6 806-2CD00 safety relay

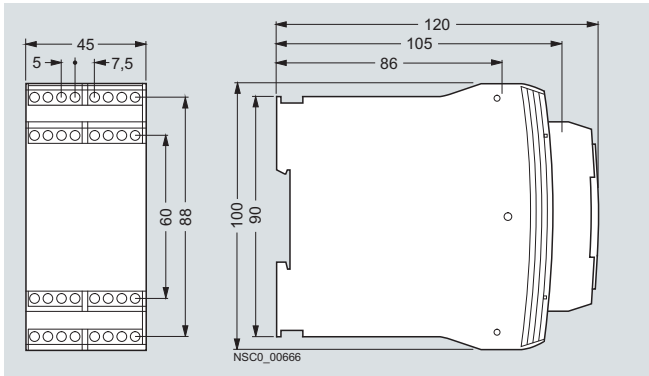

3SE6 Magnetically Operated Switches

Magnetic monitoring systems

Schematics

3SE6 605-.BA magnetically operated switch with 3SE6 806-2CD00 safety relay, Category 3 acc. to EN ISO 13849-1

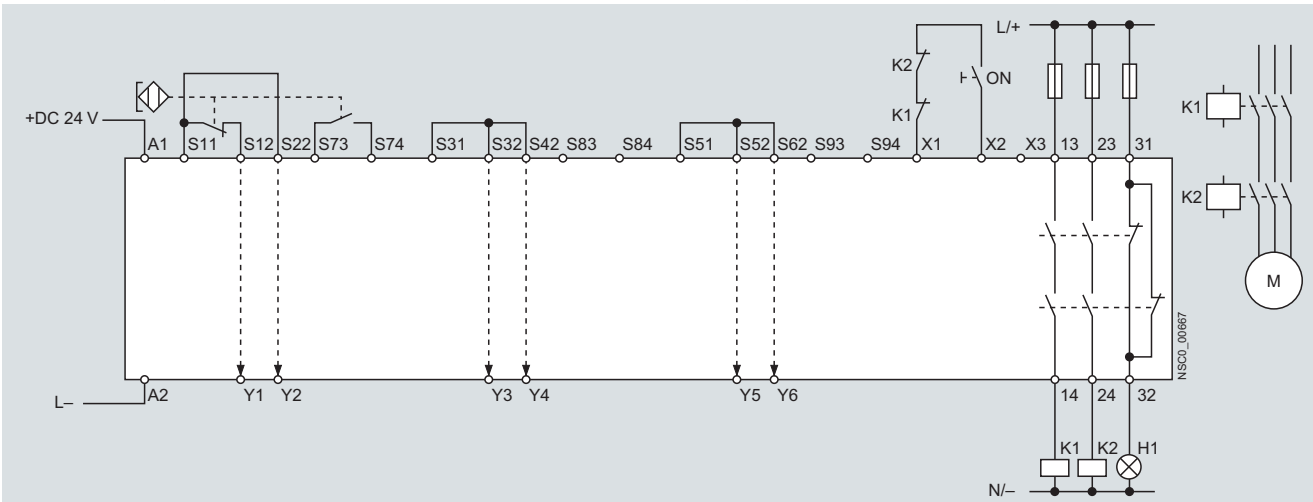

Six 3SE6 605-.BA magnetically operated switches with 3SE6 806-2CD00 safety relay, Category 3 acc. to EN ISO 13849-1

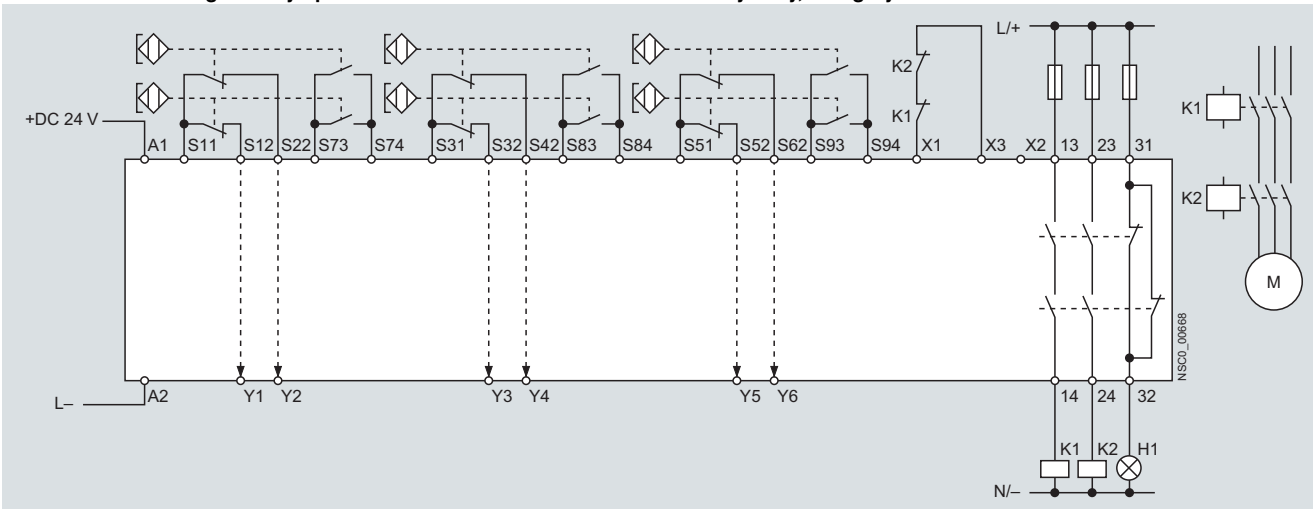

3SE6 604-.BA magnetically operated switch with 3TK28 41 safety relay, Category 4 acc. to EN ISO 13849-1

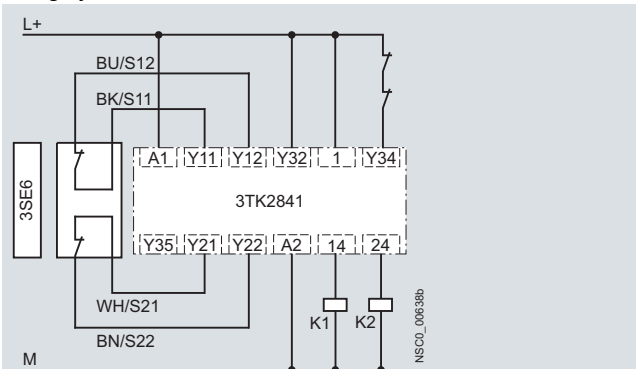

Contact block connection

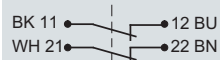

NSCO_00640a

The specified switch position refers to the basic position when the cover, hinge switch etc. is closed.

3SE6 604-.BA magnetically operated switch to ASIsafe, K45F or K60F safe compact module, Category 4 acc. to EN ISO 13849-1

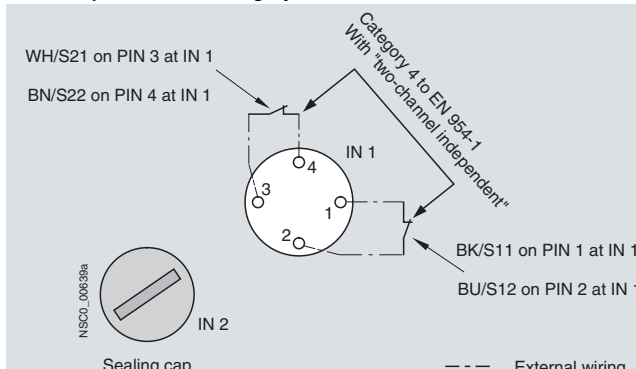

Color code abbreviations for the connecting cables acc. to IEC 60757:

- BK = black
- BU = blue
- BN = brown
- WH = white

8

Commanding and Signaling Devices



9/2	Introduction
9/4	3SB2 Pushbuttons and Indicator Lights, 16 mm
9/7	General data Project planning aids
9/8	3SB3 Pushbuttons and Indicator Lights, 22 mm
9/13	General data <u>Enclosures</u> General data <u>AS-Interface Enclosures</u>
9/15	General data
9/16	<u>Project planning aids</u>
9/25	3SB3 Two-Hand Operation Consoles Plastic and metal enclosures
9/26	3SE7 Cable-Operated Switches Metal enclosures
9/30	3SE2, 3SE3 Foot Switches Plastic and metal enclosures
9/32	8WD4 Signaling Columns General data
9/36	8WD42 signaling columns, 50 mm diameter
9/37	8WD44 signaling columns, 70 mm diameter
9/38	8WD5 Integrated Signal Lamps 8WD53 integrated signal lamps, 70 mm diameter

Commanding and Signaling Devices

Introduction

Overview

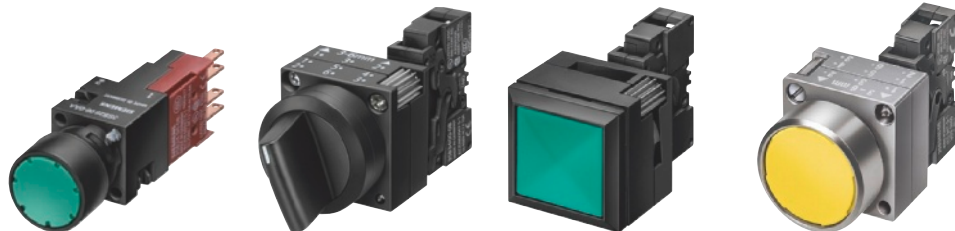

3SB2

3SB30, 3SB32

3SB31, 3SB33

3SB35, 3SB36

Pushbuttons and indicator lights

Designs

	3SB2	3SB30, 3SB32	3SB31, 3SB33	3SB35, 3SB36
Nominal diameter	16 mm	22 mm	26 mm × 26 mm	22 mm
Version	Plastic, round	Plastic, round	Plastic, square	Metal, round

Actuators

Pushbuttons and switches	✓ ¹⁾	✓	✓	✓
Illuminated pushbuttons and switches	✓ ¹⁾	✓	✓	✓
Mushroom pushbuttons	--	✓	--	✓
Push-pull buttons	--	✓	--	✓
EMERGENCY-STOP mushroom pushbuttons	✓	✓	✓	✓
Selector switches	✓	✓	✓	✓
Key-operated switches	✓	✓	✓	✓

Special actuators

Coordinate switches	--	✓	--	--
Twin pushbuttons	--	✓	--	--
Potentiometer drives	--	✓	--	--

Indicators

Indicator lights	✓	✓	✓	✓
Acoustic signaling devices	--	✓	--	--

Contact blocks

Single-pole	✓	✓	✓	✓
Two-pole	✓	✓	✓	✓

Lampholders

Wedge bases	✓	✓ (with solder connections)	✓ (with solder connections)	✓ (with solder connections)
BA 9s bases	--	✓	✓	✓
With integrated LED	--	✓	✓	✓

Terminals

Plug-in connection	✓	--	--	--
Screw terminals	--	✓	✓	✓
Spring-type terminals	--	✓	✓	✓
Solder pins	✓	✓	✓	✓
AS-Interface	--	✓	✓	✓

AS-Interface solutions

For AS-Interface solutions, see Catalog IK PI "Industrial Communication".

AS-Interface EMERGENCY-STOP according to ISO 13850

Using a special F adapter, EMERGENCY-STOP devices according to ISO 13850 can be directly connected through the standard AS-Interface with safety-oriented communication.

AS-Interface enclosures and front panel modules

For customized enclosures with connection to AS-Interface, see Catalog IK PI.

For front panel modules with one 4I/4O slave for connection of four 3SB3 control devices, see Catalog IK PI.

- ✓ Standard
- Not available
- Optional
- ¹⁾ Only pushbuttons, no pushbutton switches.



	3SB38	3SB38 6	3SE7, 3SF2	3SE29
	Enclosures	Two-hand oper. consoles	Cable-operated switches	Foot switches
Enclosure				
Plastic	✓	✓	--	✓
Metal	✓	✓	✓	✓
Actuators				
Pushbuttons and switches	✓	✓	--	✓
Illuminated pushb. and switches	✓	✓	--	--
Mushroom pushbuttons	✓	✓	--	--
Push-pull buttons	✓	--	--	--
EMERG.-STOP mushroom pushb.	✓	✓	✓	--
Selector switches	✓	--	--	--
Key-operated switches	✓	--	--	--
Bowden wires	--	--	✓	--
Indicators				
Indicator lights	✓	--	✓	--
Acoustic signaling devices	✓	--	--	--
Contact blocks				
Single-pole	✓	✓	--	--
Two-pole	--	✓	✓	✓
Three-pole	--	--	--	✓
Four-pole	--	--	✓	✓
Terminals				
Screw terminals	✓	✓	✓	✓
Spring-type terminals	✓	☐	--	--
Molded cables	--	--	--	✓
Plug-in connection	--	☐	☐	☐
AS-Interface	✓	☐	--	--



	8WD42, 8WD44	8WD53
	Signaling columns	Integrated signal lamps
Enclosure		
Plastic	✓	✓
Metal	--	--
Lights		
Incandescent lamps	✓	✓
LEDs	✓	✓
Flashlight	✓	✓
Terminals		
Screw terminals	✓	✓
Spring-type terminals	✓	--
AS-Interface	✓	--

3SB2 Pushbuttons and Indicator Lights, 16 mm

General data

Overview

The 3SB2 pushbuttons and indicator lights are provided for front plate mounting and rear connection with flat connectors. For use on printed circuit boards, contact blocks and lampholders with solder pins are also available.

Standards

IEC 60947-5-1, EN 60947-5-1 (VDE 0660 Part 200),

IEC 60947-5-5, EN 60947-5-5 (VDE 0660 Part 210) for EMERGENCY-STOP mushroom pushbuttons.

Version with flat connector

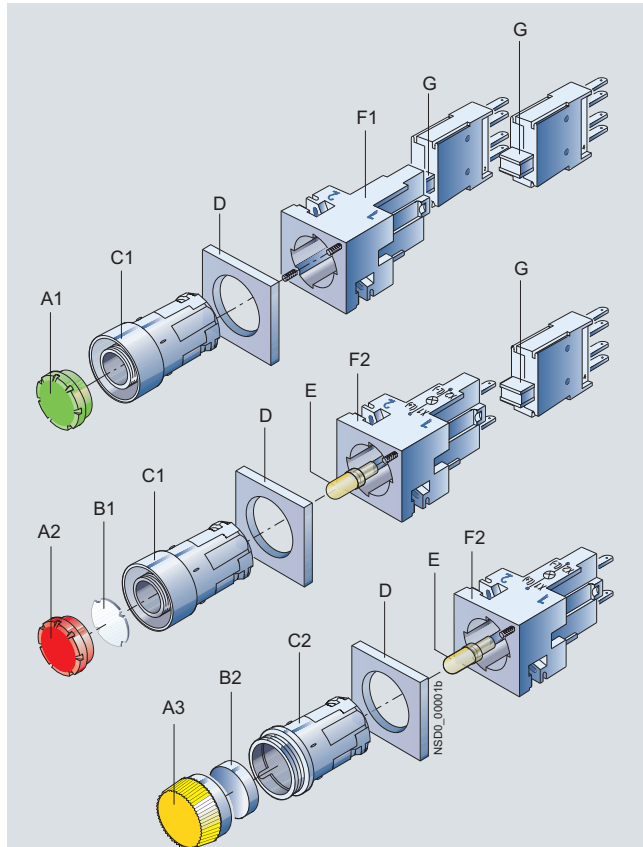

- A1 Illuminated pushbutton, flat
- A2 Pushbutton, flat
- A3 Screw lens for indicator light
- B1 Insert label for inscription
- B2 Insert cap for inscription
- C1 Collar with extruded front ring
- C2 Collar for indicator light
- D Frame for square design
- E Wedge-Base lamps W2 x 4.6 d
- F1 Holder
- F2 Lampholder with holder
- G Contact blocks (1 NO or 1 NC) for snapping on to holder and/or lampholder

For PCB mounting

For use on printed circuit boards, special contact blocks and lampholders for soldering into the printed circuit board are available. For this purpose, the blocks are fitted with 0.8 mm x 0.8 mm solder pins of length 3.5 mm.

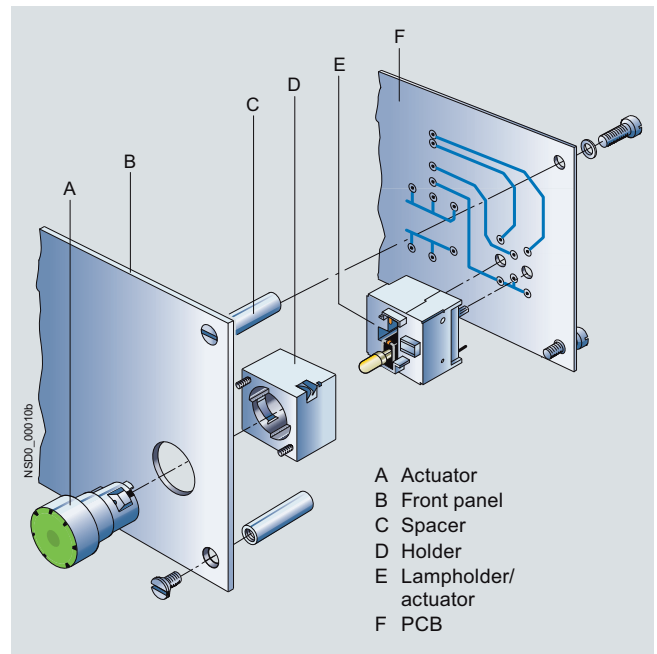

- A Actuator
- B Front panel
- C Spacer
- D Holder
- E Lampholder/actuator
- F PCB

Design

Design versions

Two design versions can be mounted:

- Round design: The 3SB2 pushbuttons and indicator lights are assembled with the modules – actuator, holder, contact block and lampholder. Depending on the specific application, various versions can be assembled. Complete units are offered for the most commonly used applications.
- Square design: With square, black frames the round units can be given a square look. The frames are inserted underneath the round actuators. Further mounting is the same as for the round version.

Mounting and fixing

Mounting dimensions according to EN 50007
(not applicable to EMERGENCY-STOP mushroom pushbuttons):

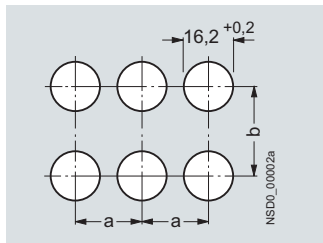

Minimum spacing	a	b
Round version	19	19
Square version without inscription label	21	21
Round and square version with inscription label	21	32
For 2 selector switches with 3 switch positions, latching, side by side	21	21

For mounting, the actuator or the lens assembly is inserted from the front into the hole in the front plate. Four small nubs ensure a secure fitting in the hole. The holder is plugged on the actuator or the lens assembly from behind and automatically snaps into place. The module is screwed down tightly with 2 screws on the holder and thus levels panel thickness from 1 to 6 mm.

One or two contact blocks can be mounted on the holder. They are inserted into the holder with slide slots and held down with two snap brackets.

If a command position is fitted with an indicator light or illuminated pushbutton, a lamp socket with lampholder must be used instead of a holder. It is suitable for incandescent lamps or LEDs with bases of type W2 × 4.6d.

Terminals

The contact blocks and the lampholder are equipped with flat connectors acc. to IEC 60760 which can also be used as solder connections.

To permit through-connection, all terminals are provided with two tabs.

For PCB mounting

The command position comprises the actuator, e. g. 3SB2 pushbutton, illuminated pushbutton or indicator light, which is mounted in the front plate, and a contact block and a lampholder which are soldered to the PCB. For this purpose, the contact blocks and lampholders are fitted with 0.8 mm × 0.8 mm solder pins of length 3.5 mm.

Mounting and fixing

Mounting dimensions according to EN 50007.

The actuators are mounted in the same way as 3SB2 front plate mounting devices.

The contact blocks and lampholders are plugged into the printed circuit board by means of their solder pins and can be flow-soldered. After soldering, the devices must be flush with the board and perpendicular to it. The printed circuit board must be supported on spacing bolts so that it cannot sag or bend more than 0.1 mm.

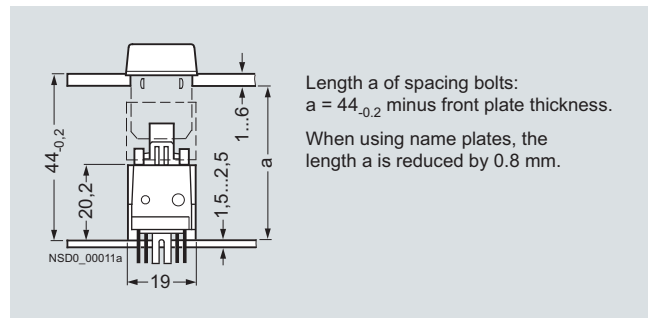

Length a of spacing bolts:
 $a = 44_{-0,2}$ minus front plate thickness.

When using name plates, the length a is reduced by 0.8 mm.

Illuminated pushbutton with solder pin connection

To avoid bending the PCB when the pushbuttons are operated, sufficient spacing bolts must be provided as shown in the table below:

PCB thickness	Max. distance between spacing bolts
1.5 mm	80 mm
2.5 mm	150 mm
When using EMERGENCY-STOP pushbuttons	always 50 mm

These details are based on epoxy resin glass fiber mat.

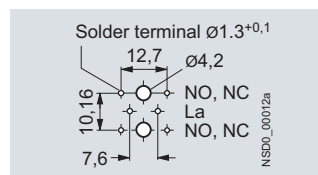

Solder pin spacing

3SB2 Pushbuttons and Indicator Lights, 16 mm

General data

Technical specifications

Type	3SB2	
Contact blocks and lampholders		
Standards	IEC 60947-5-1, EN 60947-5-1 IEC 60947-5-5, EN 60947-5-5	
Rated insulation voltage U_i	V	250
Conventional thermal current I_{th}	A	10
Rated operational current I_o at rated operational voltage U_e		
• Alternating current AC-12 - At $U_e = 230$ V	A	10
• Alternating current AC-15 - At $U_e = 24$ V	A	4
- At $U_e = 60$ V	A	4
- At $U_e = 110$ V	A	4
- At $U_e = 230$ V	A	4
• Direct current DC-12 - At $U_e = 24$ V	A	6
- At $U_e = 60$ V	A	5
- At $U_e = 110$ V	A	2.5
- At $U_e = 230$ V	A	1
• Direct current DC-13 - At $U_e = 24$ V	A	3
- At $U_e = 60$ V	A	1.5
- At $U_e = 110$ V	A	0.7
- At $U_e = 230$ V	A	0.3
Contact stability		
• Test voltage/test current	5 V/1 mA	
Lamps		
• Bases	Wedge base W2 × 4.6 d	
• Rated voltage	V	6, 12, 24, 30, 48, 60
• Rated power, max.	W	1
Short-circuit protection weld-free acc. to IEC 60947-5-1		
• DIAZED fuse links, operational class gL/gG	10 A TDz, 16 A Dz	
• Miniature circuit breaker with C characteristic acc. to IEC 60898	10 A	
Electrical endurance		
• For operational class AC-15 with 3RT10 15 to 3RT10 26 contactors	10 × 10 ⁶ operating cycles	
Mechanical endurance		
	10 × 10 ⁶ operating cycles	
Degree of protection acc. to IEC 60529		
• Connection of contact blocks and lampholders behind the front panel	IP00	
• Contact chambers of the contact blocks behind the front panel	IP40	
Finger-safe acc. to EN 50274 and BGV A3		
	With voltages > 50 V AC or 120 V DC, insulation sleeves must be fitted to the unassigned tab connections.	
Connection		
• Plug-in connection with flat connectors for plug-in sleeves acc. to IEC 60760	Flat connector 2 × 2.8/0.8 mm	
Data acc. to UL and CSA		
Rated voltage		
• Contact blocks	V	250 AC
• Indicator light (lamp with wedge base W2 × 4.6 d)	V	60; 1 W
Uninterrupted current	A	5
Switching capacity	B 300, R 300	
Actuators and indicators		
Mechanical endurance		
• Pushbuttons	10 × 10 ⁶ operating cycles	
• Actuators, rotary or latching	3 × 10 ⁵ operating cycles	
• Illuminated pushbuttons	3 × 10 ⁶ operating cycles	
Climatic withstand capability		
	Climate-proof; suitable for marine applications	
Ambient temperature		
• During operation, non-illuminated devices and complete with LED	°C	-25 ... +70
• During operation, devices with incandescent lamp	°C	-25 ... +60
• During storage, transport	°C	-40 ... +80
Degree of protection acc. to IEC 60529		
• Actuators and indicators	IP65	
• Actuators and indicators with protective cap	IP67	
Protective measures		
• For mounting in metal front plates and enclosures	The actuators and lens assemblies must not be included in the protective measures.	
• For fitting into enclosures with total insulation	The protective measure "Total insulation" is retained.	
Shock resistance acc. to IEC 60068-2-27		
• Shock amplitude	≤ 50 g	
• Shock duration	ms	11
• Shock form	Half-sine	

Dimensional drawings

Actuators

Pushbutton or illuminated pushbutton with flat button

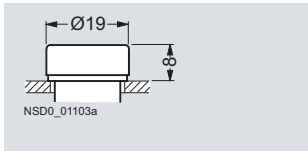

Selector switch

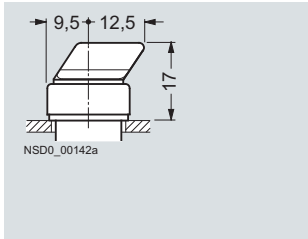

Pushbutton or illuminated pushbutton with raised button

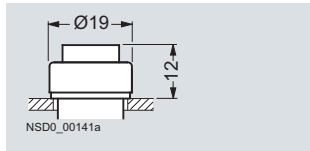

CES key-operated switch

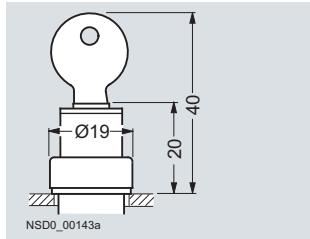

Indicator light

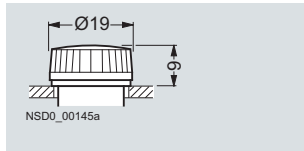

EMERGENCY-STOP mushroom pushbutton acc. to ISO 13850

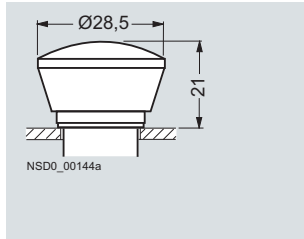

Contact blocks with flat connector

Pushbutton and contact block with holder for front panel mounting

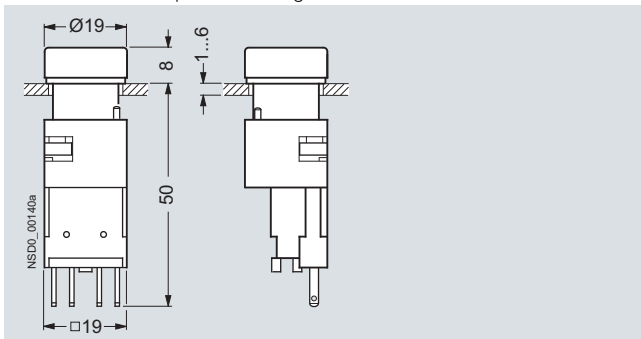

Contact blocks with solder pins for use on printed circuit boards

Illuminated pushbutton

with contact block and lampholder with solder pins

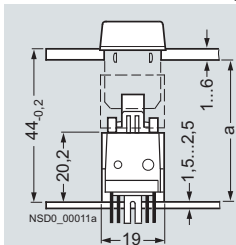

Length **a** of spacing bolts:
a = 44_{-0,2} minus front panel thickness.
 When using name plates, the length **a** is reduced by 0.8 mm.
 To avoid bending of the PCB when the actuator is operated, sufficient spacing bolts must be provided spaced as shown in the table below:

PCB thickness	Max. distance between spacing bolts
1.5 mm	80 mm
2.5 mm	150 mm
When using EMERGENCY-STOP pushbuttons	generally 50 mm

These details are based on epoxy resin glass fiber mat.

Solder pin spacing

Solder terminal Ø1.3^{+0,1}

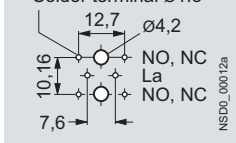

Mounting dimensions

Contact blocks and indicator lights
 (except EMERGENCY-STOP mushroom pushbuttons)

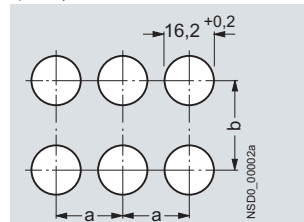

Minimum spacing	a	b
Round version	19	19
Square version without inscription label	21	21
For round and square versions with inscription label	21	32
For 2 selector switches and 3 switch positions, maintained contact, side by side	21	21

Accessories

Complete plug

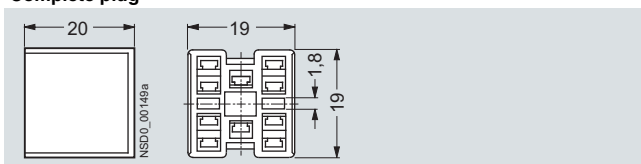

3SB3 Pushbuttons and Indicator Lights, 22 mm

General data

Overview

Front plate mounting

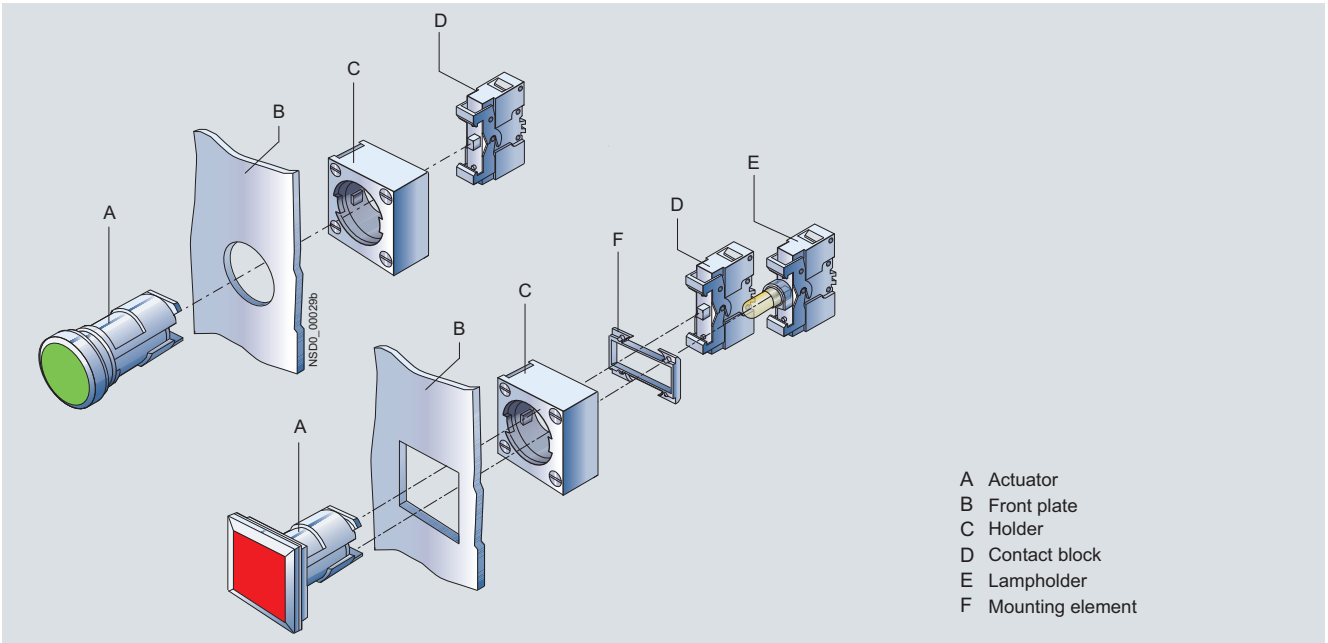

Use on printed circuit boards

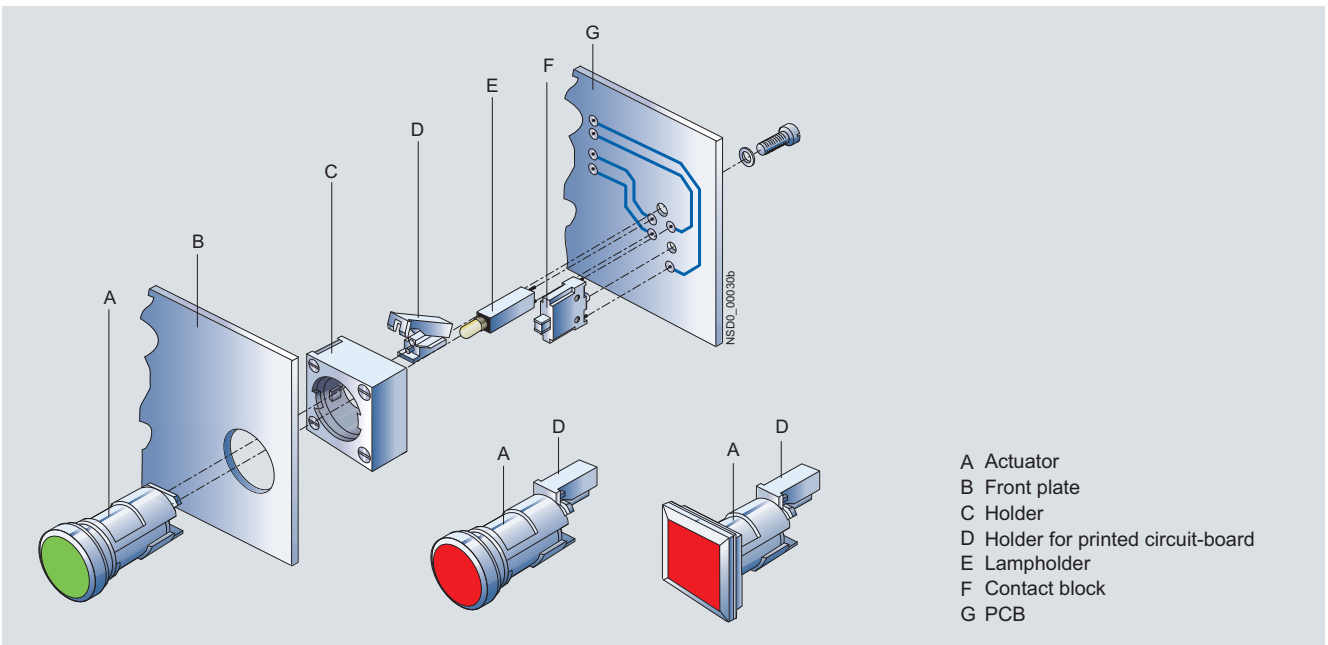

3SB3 Pushbuttons and Indicator Lights, 22 mm

General data

Design

The 3SB3 series is a modular range of commanding and signaling devices for front panel mounting and rear conductor connection. As an alternative, individual elements can also be supplied for use on printed circuit boards. Complete units are offered for the most commonly used applications.

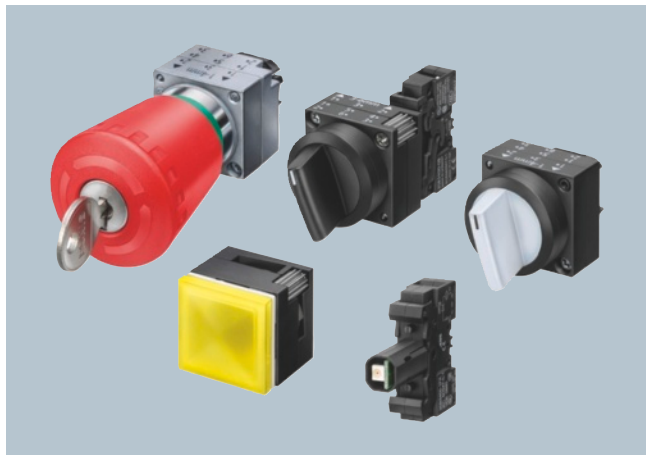

The 3SB3 series is available:

- Made of molded plastic in flat, round and square design
- Made of metal in round design.

The devices are of modern industrial design and can be mounted rapidly by a single person. The operating surfaces of the pushbuttons and illuminated pushbuttons are concave. The lenses of the indicator lights are convex.

The metal version with a high degree of protection according to IP67 and NEMA 4 is available for the world market.

One command point comprises:

- An actuator or lens assembly in front of the control panel
- A holder for mounting behind the control panel
- Up to 3 contact blocks and/or 1 lampholder behind the control panel
- A comprehensive range of accessories for inscription

Two contact blocks can be snapped onto the actuator in the standard version.

When three contact blocks or illuminated actuators are required, an additional holder must be plugged onto the actuator from the rear.

- 3SB39 01-0AB holder for 3 contact blocks or for 2 contact blocks and 1 lampholder
- 3SB39 01-0AC holder with pressure plates for actuating a central contact block when using a selector switch, key-operated switch and twin pushbutton with 3 contact blocks.

For illuminated pushbuttons, illuminated switches and illuminated selector switches the holder is included in the scope of supply as standard.

Standards

IEC 60947-1, EN 60947-1.

IEC 60947-5-1, EN 60947-5-1,

IEC 60947-5-5, EN 60947-5-5
for EMERGENCY-STOP mushroom pushbuttons.



"Intrinsic safety" type of protection EEx i according to ATEX directive 94/9/EC

The pushbuttons and indicator lights in round design can also be used in hazardous areas. The 3SB34 ..-0. contact blocks and the 3SB34 ..-1A lampholders (with 3SB39 01-1.A LED lamp) with screw terminals or spring-type terminals can be used.

See Catalog LV 1, Chapter 20 "Appendix" --> "Standards and approvals" --> "Type overview of approved devices for potentially explosive areas (ATEX explosion protection)".

Connection methods

The devices are available with screw terminals (box terminals), spring-type terminals or solder pins.

-  Screw terminals
-  Spring-type terminals
-  Solder pin connections

These connections are indicated in the Technical specifications by orange backgrounds.

3SB3 Pushbuttons and Indicator Lights, 22 mm

General data

Design

Holder

The holders are used for mounting the actuating or signaling elements and are plugged into the rear of the front plate.

The holder for the round versions is set to a control panel thickness of 1 to 4 mm when delivered and is placed in the direction of the arrow \uparrow 1–4 mm \uparrow on the actuator/indicator from the back. The fixing screw is located underneath, on the right.

For a switchboard thickness of 3 to 6 mm, the holder is reversed and mounted in the direction of the arrow at \uparrow 3–6 mm \uparrow and the fixing screw is located on the upper right. In this case, the fixing screw must be rotated anticlockwise to its limit before mounting the holder.

The control panel thickness of 1 to 4 mm can be compensated with the holder for the square version.

When label holders, protective caps or similar accessories are used, the greatest permissible control panel thickness must be reduced by the wall thickness of the accessory part.

Contact blocks and lampholders

The contact blocks are fitted with a slow-action contact (1 NO contact or 1 NC contact) with double operating contacts. These ensure a high switching reliability even with small voltages and currents, such as 5 V/1 mA. They are suitable for use in solid-state systems as well as conventional controls.

The switch contacts of the NC contact are positively driven.

For illuminated elements, lampholders with an integrated LED or with a base for replaceable bulbs can be supplied.

Contact blocks and lampholders feature terminal designations according to EN 50013.

Mounting

The 3SB3 devices can be easily and quickly mounted:

- Actuators or indicator lights are positioned in the opening of the front panel from the front
- Position the holder from the rear
- Tighten the screw on the holder
- Snap on the contact block or the lampholder directly onto the actuator from the back

Connection methods

The following devices are available:

- Screw terminal (box terminals)
- Spring-type terminals or
- Solder connections (0.8 mm × 0.8 mm solder pins)

The devices with screw terminals have open terminals, screws that cannot be lost, funnel-shaped cable entries and screwdriver fed openings, all of which saves time when connecting and enables the use of motorized screwdrivers.

The devices with spring-type terminals can be connected quickly and tightly, and when single-pole blocks are used the command point can be butt-mounted.

Inscriptions

Direct inscription using a laser or by means of insert labels or name plates.

For applications requiring less robustness there is the Label Designer software and corresponding labels. The user can use these to create his own inscriptions with text or symbols.



Enclosure

Plastic and metal enclosures with 1, 2, 3, 4 or 6 command points are available for the round design. Enclosures with more than 6 command points can be supplied upon request. They are suitable for the round and square design.

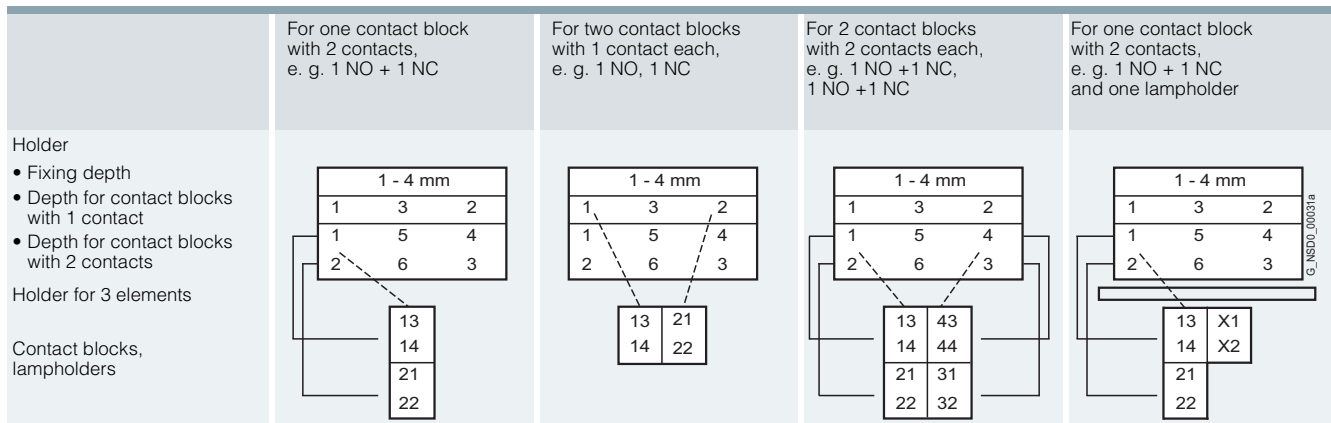
Contact assignment



Technical specifications

Type		3SB34 00-0, 3SB34 20-0	3SB14 00-0J	3SB34 00-1, 3SB34 20-1	3SB34 03-0, 3SB34 23-0	3SB34 03-1, 3SB34 23-1	3SB34 11-0	3SB34 11-1
Contact blocks and lampholders								
Standards		IEC 60947-5-1, IEC 60947-5-5, EN 60947-5-1, EN 60947-5-5						
Connection type		 Screw terminals			 Spring-type terminals		 Solder pins	
Rated insulation voltage U_i	V	400		250		400	250	60
For degree of pollution acc. to IEC 60947-1		Class 3			Class 3		Class 3	
Rated impulse withstand voltage U_{imp}	kV	4		4		4	4	1.5
Conventional thermal current I_{th}	A	10		--		10	--	10
Rated operational current I_e for rated operational voltage U_e								
• Alternating current 50/60 Hz, AC-12								
- At $U_e = 24$ V	A	10		--		10	--	10
- At $U_e = 48$ V	A	10		--		10	--	10
- At $U_e = 110$ V	A	10		--		10	--	10
- At $U_e = 230$ V	A	10		--		10	--	10
- At $U_e = 400$ V	A	10		--		10	--	--
• Alternating current 50/60 Hz, AC-15								
- At $U_e = 24$ V	A	6		--		6	--	4
- At $U_e = 48$ V	A	6		--		6	--	4
- At $U_e = 110$ V	A	6		--		6	--	4
- At $U_e = 230$ V	A	6		--		6	--	4
- At $U_e = 400$ V	A	3	4	--		3	--	--
• Direct current DC-12								
- At $U_e = 24$ V	A	10	10	--		10	--	10
- At $U_e = 48$ V	A	5	--	--		5	--	5
- At $U_e = 110$ V	A	2.5	2	--		2.5	--	2.5
- At $U_e = 230$ V	A	1	0.5	--		1	--	1
• Direct current DC-13								
- At $U_e = 24$ V	A	3	5	--		3	--	3
- At $U_e = 48$ V	A	1.5	--	--		1.5	--	1.5
- At $U_e = 110$ V	A	0.7	0.5	--		0.7	--	0.7
- At $U_e = 230$ V	A	0.3	0.2	--		0.3	--	0.3
Contact stability								
• Test voltage	V	5		--		5	--	5
• Test current	mA	1		--		1	--	1
Lampholders		--		BA 9s	--	BA 9s	--	Wedge bases
Lamps		--		Incandescent lamps, glow lamps and LED lamps	--	Incandescent lamps, glow lamps and LED lamps	--	Incandescent lamps and LED lamps
Short-circuit protection, weld-free, acc. to IEC 60947-5-1		Dz10 A						
• DIAZED fuse links, operational class gG acc. to IEC 60269-3-1		Dz 16 A						
• DIAZED fuse links, quick acc. to DIN VDE 0635		10						
• Miniature circuit breaker with C characteristic acc. to IEC 60898	A	10						
Mechanical endurance		10×10^6 operating cycles						
Electrical endurance		10×10^6 operating cycles						
• For operational class AC-15 with 3RT10 15 to 3RT10 26 contactors		10×10^6 operating cycles						
• With operational class DC-12, DC-13		With direct current, the contact endurance depends not only on the breaking current but also on the operational voltage, the circuit inductance and the speed of switching.						
Switching frequency	1/h	1000 operating cycles						
Degree of protection acc. to IEC 60529		IP20						
• Terminals		IP40						
• Contact chambers			--		IP40	--	IP40	--
Touch protection acc. to EN 50274 and BGV A3		Finger-safe			Finger-safe		--	
Conductor cross-sections¹⁾								
• Finely stranded, without end sleeves	mm ²	--			2 × (0.25 ... 1.5)		--	
• Finely stranded, with end sleeves acc. to DIN 46228	mm ²	2 × (0.5 ... 1.5)			2 × (0.25 ... 0.75)		--	
• Solid	mm ²	2 × (1 ... 1.5)			2 × (0.25 ... 1.5)		--	
• Solid, with end sleeves acc. to DIN 46228	mm ²	2 × (0.5 ... 0.75)			--		--	
• AWG cables, solid or stranded		2 × AWG 18 ... 14			2 × AWG 24 ... 16		--	
Tightening torque, terminal screw	Nm	0.8			--		--	
Solder pins	mm ²	--			--		0.8 × 0.8	

1) For standard screwdriver size 2 or Pozidriv 2.

3SB3 Pushbuttons and Indicator Lights, 22 mm

General data

Type	3SB34 00-0, 3SB34 20-0	3SB34 00-1, 3SB34 20-1	3SB34 03-0, 3SB34 23-0	3SB34 03-1, 3SB34 23-1	3SB34 11-0	3SB34 11-1
Data acc. to UL and CSA						
Rated operational voltage	V AC 300	--	300	--	300	--
Conventional thermal current (uninterrupted current) A	10	--	10	--	10	--
Switching capacity	A 300, R 300, A 600 same polarity					
Rated voltage (lamps)						
• Lamp with BA 9s base	V AC --	125	--	125	--	--
• Lamp with wedge base	V AC --	60	--	60	--	60
• Lampholders with integrated LED	V --	24 AC/DC, 110 AC, 230 AC	--	24 AC/DC, 110 AC, 230 AC	--	--
Rated power (lamps)	W --	2.5	--	2.5	--	1

Type	3SB30, 3SB32, (3SB31)	3SB31, 3SB33	3SB35, 3SB36
Actuators and indicators			
Enclosure material	Plastic		Metal
Design	Round	Square	Round
Terminal designation acc. to EN 50013	Identification number on the holder, function digit on the contact block		
Device identification	Snap-on label		
Tightening torques			
• Screw on holder	Nm	Max. 1	
Mechanical endurance			
• Pushbuttons	10 × 10 ⁶ operating cycles		
• Illuminated pushbuttons	3 × 10 ⁶ operating cycles		
• Actuators, rotary or maintained contact	3 × 10 ⁵ operating cycles		
• Key-operated switch with key monitoring	1 × 10 ⁵ operating cycles		
Switching frequency	1/h	1000 operating cycles	
Climatic withstand capability acc. to EN ISO 6270-2	Climate-proof KTW24; suitable for marine applications		
Ambient temperature			
• During operation, non-illuminated and with LED	°C	-25 ... +70	
• During operation, devices with incandescent lamp	°C	-25 ... +60	
• During storage, transport	°C	-40 ... +80	
Degree of protection acc. to IEC 60529			
• Actuators and indicators, standard	IP66	IP65	IP67 and NEMA Type 4
- With protective caps	IP67	IP67	--
• Key-operated switch with key monitoring	IP54	--	--
• Twin pushbuttons (3SB31)	IP65	--	--
Protective measures	Protective measures are met automatically when the actuators and lens assemblies are mounted on metal front plates and enclosures. When mounted in insulated enclosures, the "total insulation" protective measures are met.		
Shock resistance acc. to IEC 60068-2-27 For half-sine shock type, 11 ms shock duration			
• Devices without incandescent lamp	≤ 50 g		
• Devices with incandescent lamp	≤ 30 g		
Vibration resistance acc. to IEC 60068-2-6			
• Acceleration at frequency 20 ... 200 Hz	5 g		

Type	3SB38 0.-0, 3SB38 0.-1	--	3SB38 0.-2, 3SB38 0.-3
Enclosure			
Enclosure material	Plastic		Metal
Actuators and indicators	Plastic, round		Metal, round
Degree of protection acc. to IEC 60529	IP65		IP67 and NEMA Type 4
Resistance to extreme climates acc. to DIN 50017	KTW 24		KTW 24

3SB3 Pushbuttons and Indicator Lights, 22 mm Enclosures

General data

Overview



Enclosed pushbuttons and indicator lights are used as hand operated control devices for separately allocated control units and cabinets. The devices are suitable for use in any climate.

Enclosures with handle are available for suspension (e. g. for crane control units).

The enclosed pushbuttons and indicator lights are available with conventional controls as well as for connection to the AS-Interface bus system.

The following versions are available:

- Enclosure with standard fittings with 1 to 3 command points
- Enclosure with customized equipment with 1 to 6 command points
- Empty enclosures (individual parts must be ordered separately).

Customer-specific enclosures

On request enclosures with more than 6 command points can also be supplied with AS-Interface connection.

For fully equipped AS-Interface enclosures, see Catalog IK PI.

Enclosures with standard fittings

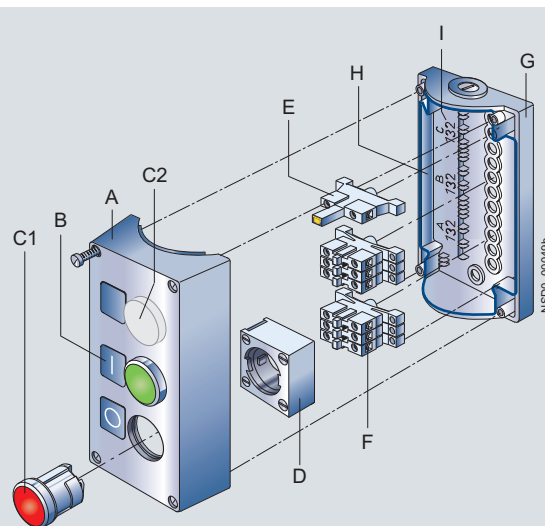

- A Top part of enclosure
- B Inscription labels
- C1 Pushbutton
- C2 Indicator light
- D Holder
- E Contact designations
- F Contact blocks, lampholders for floor mounting
- G Bottom part of enclosure
- H Identification letters for the command points
- I Identification number

Standards

IEC 60947-5-1 (VDE 0660 Part 200).

3SB3 Pushbuttons and Indicator Lights, 22 mm

Enclosures

General data

Design

Enclosure

Plastic and metal enclosures with 1, 2, 3, 4 or 6 command points are available. The mounting holes are located external to the terminal compartment.

Cable routing: on the top and bottom narrow ends of the enclosure for an M20 or M25 metric cable gland.

Enclosure color:

- Cover: RAL 7035 (light gray),
- For EMERGENCY-STOP: RAL 1004 (yellow),
- Base: RAL 9005 (black).

The plastic enclosures comply with the "total insulation" protective measure.

Actuators

Round actuators and lens assemblies for a nominal diameter of 22 mm can be used.

The actuators are fitted through the hole in the cover of the enclosure and are connected to the holder supplied with the actuator and secured in position.

Plastic enclosures are equipped as standard with actuators and indicators made of plastic, metal enclosures are equipped with actuators and indicators made of metal.

Contact blocks and lampholders

Contact blocks and lampholders for floor mounting are snapped into the bottom part of the enclosure. For each command points, the following components can be fitted:

- 3 contact blocks or
- 2 contact blocks + 1 lampholder or lampholder with integrated voltage reducer.

The contact blocks have moving double-break contacts and therefore a high contact stability, i. e. they are also suitable for operation in solid-state controls. Function numbering is shown on the contact block.

Single-pole contact blocks and lampholders for front plate mounting can also be used.

3SB3 Pushbuttons and Indicator Lights, 22 mm AS-Interface Enclosures

General data

Overview



Distributed command devices of the 3SB3 series can be quickly connected to the AS-Interface using AS-Interface enclosures. Using suitable components you can make your own enclosures with integrated AS-Interface or flexibly modify existing enclosures.

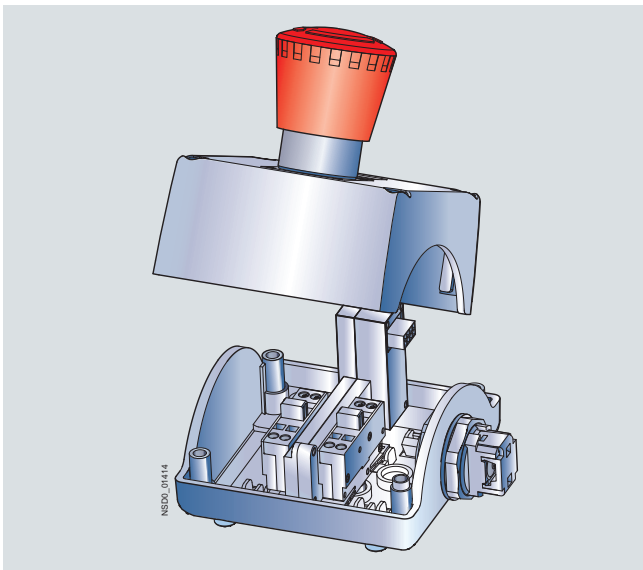

EMERGENCY-STOP enclosures

Equipment

The enclosures with integrated AS-Interface are equipped with contact blocks and LED lampholders with spring-type connections from the 3SB3 series along with the slave(s) required to connect the contact blocks and lampholders to AS-Interface.

AS-Interface modules, cable sets and a connection element are required in addition to connect the contact blocks and LED lampholders.

Installation of AS-Interface slaves

The following slave types are available for connecting the command points:

- Slave in A/B technology with 4 inputs and 3 outputs
- Slave with 4 inputs and 4 outputs
- F slave with 2 safe inputs for EMERGENCY-STOP

The following table shows the maximum number of equippable slaves:

Enclosures for	Number of slaves for enclosures without EMERGENCY STOP	Number of slaves for enclosures with EMERGENCY STOP
1 command point	Not available	1x F slave
2 command points	1 x slave 4I/4O or 4I/3O	Not available
3 command points	1 x slave 4I/4O or 4I/3O	1 x slave 4I/4O or 4I/3O + 1 x F slave
4 command points	2 x slave 4I/4O or 4I/3O ¹⁾	2 x slave 4I/4O or 4I/3O + 1 x F slave ¹⁾
6 command points	2 x slave 4I/4O or 4I/3O	2 x slave 4I/4O or 4I/3O + 1 x F slave

¹⁾ For metal enclosures with 4 command points, only 1 x slave 4I/4O or 4I/3O is possible.

Connection

One set of links is required in each case to connect a slave to contact blocks, to lampholders and to the connection element.

The connection elements are mounted in the front-end cable glands and are used for connection of the AS-Interface or for bringing unused inputs or outputs out of the enclosure.

For connection to the AS-Interface bus there is a choice of the following options:

- Terminal for shaped AS-Interface cable. The cable is contacted by the insulation piercing method and routed past the enclosure on the outside (possible only with plastic enclosure).
- Cable gland for the shaped AS-Interface cable or round cable. The cable is routed into the enclosure (preferable for metal enclosure).
- Connection using M12 plug.

If less than all inputs/outputs of the installed slaves in an enclosure are used for connecting the command devices, free inputs and outputs can be routed on request to the outside through an M12 socket on the top or bottom side of the enclosure.

To supply inputs with power, the S+ connection of the must be assigned to the socket, for outputs the OUT- connection must be assigned.

Addressing is performed using the AS-Interface connections or the integrated addressing socket. An external power supply is not required.

3SB3 Pushbuttons and Indicator Lights, 22 mm

Project planning aids

Dimensional drawings

Mounting dimensions

Round version

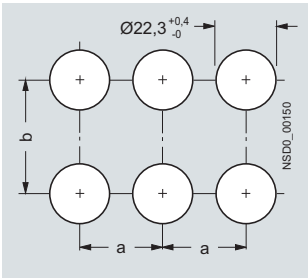

Square version

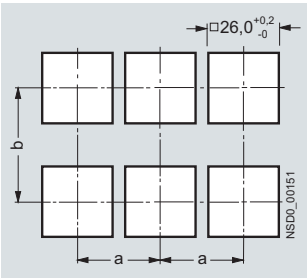

Minimum spacing

	a	b
Contact blocks (1 contact) and lampholder		
• For front plate mounting, with screw terminals	30 ¹⁾	45
• For front plate mounting, with spring-type terminals	30 ¹⁾	30 ¹⁾
• For use on PCB, with solder pin connections	30 ¹⁾	30 ¹⁾
Contact blocks with 2 contacts		
• For front plate mounting	30 ¹⁾	50
When using holders for inscription labels		
• 12.5 mm × 27 mm	30 ¹⁾	45 ²⁾
• 27.0 mm × 27 mm	30 ¹⁾	60

1) For mushroom pushbutton, EMERGENCY-STOP and push-pull button:
Note mushroom diameter d = 40 mm or 60 mm.
2) 60 mm with contact blocks having two contacts.

Molded-plastic version, round

Pushbutton, pressure switch, illuminated pushbutton or illuminated pressure switch with flat button

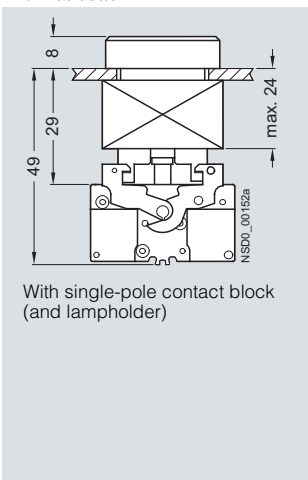

Pushbutton or illuminated pushbutton with raised button

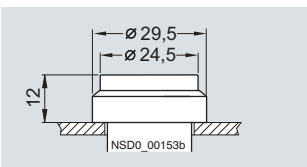

Pushbutton with raised front ring

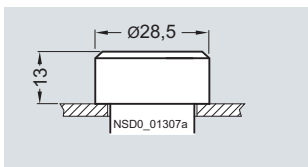

Pushbutton with raised front ring, castellated

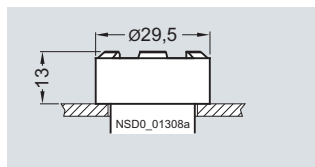

Mushroom pushbutton, illuminated mushroom pushbutton, push-pull button or illuminated push-pull button, Ø 30 mm

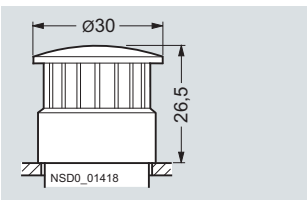

Mushroom pushbutton, illuminated mushroom pushbutton, push-pull button or illuminated push-pull button, Ø 40 mm

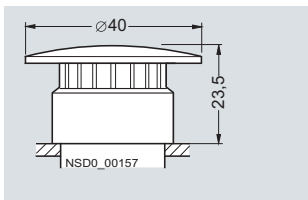

Mushroom pushbutton, illuminated mushroom pushbutton, push-pull button or illuminated push-pull button, Ø 60 mm

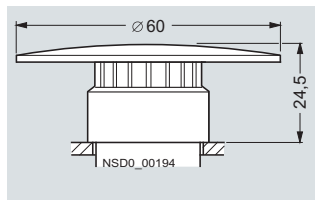

Selector switch or illuminated selector switch

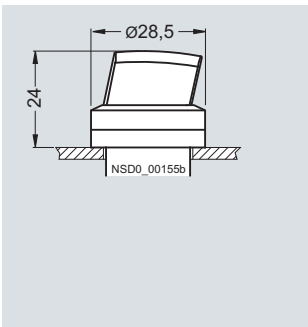

RONIS key-operated switch

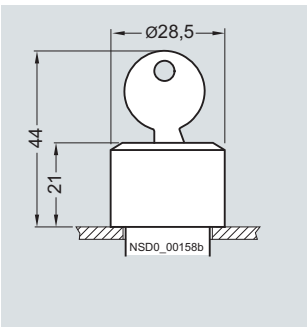

BKS, CES, O.M.R. key-operated switch

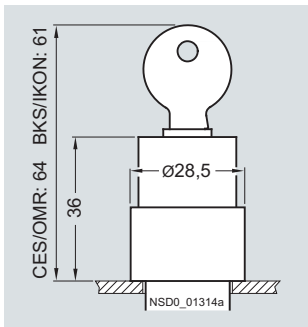

Coordinate switch

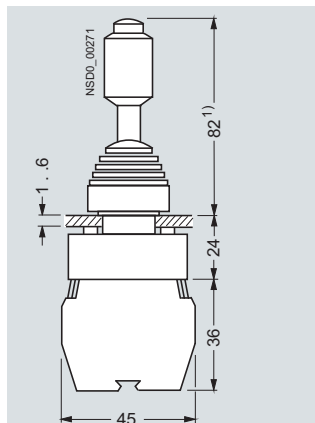

Pushbutton with raised button, latchable

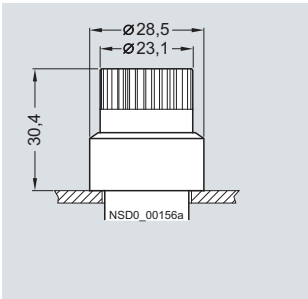

Potentiometer drive with shaft Ø 6 mm, 30 ... 32 mm long

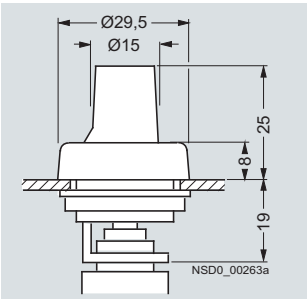

Pushbutton with extended stroke

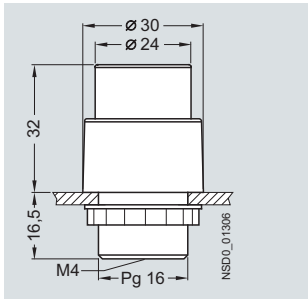

1) 82 with mechanical interlock, 77 without mechanical interlock.

3SB3 Pushbuttons and Indicator Lights, 22 mm

Project planning aids

Molded-plastic version, round

EMERGENCY-STOP mushroom pushbutton,
 Ø 32 mm, with rotate-to-unlatch mechanism

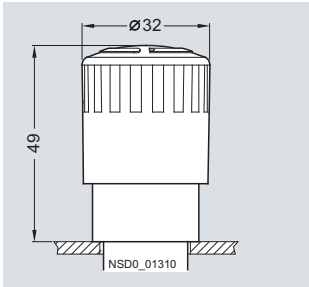

EMERGENCY-STOP mushroom pushbutton,
 Ø 40 mm, with pull-to-unlatch mechanism

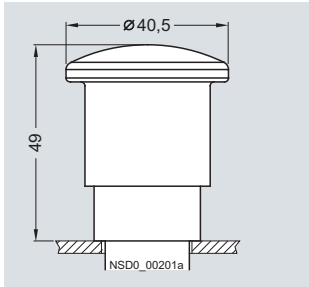

EMERGENCY-STOP mushroom pushbutton,
 Ø 40 mm, with rotate-to-unlatch mechanism

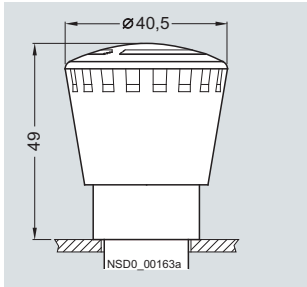

EMERGENCY-STOP mushroom pushbutton,
 Ø 60 mm, with rotate-to-unlatch mechanism

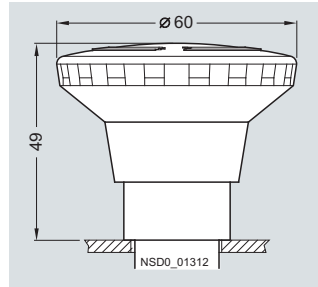

EMERGENCY-STOP mushroom pushbutton
 with RONIS lock

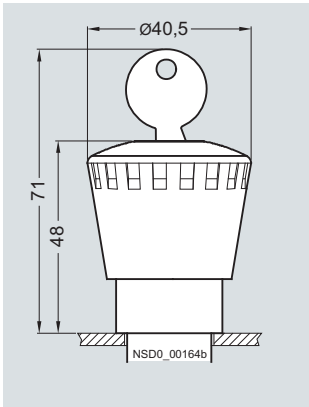

EMERGENCY-STOP mushroom pushbutton
 with BKS, CES, O.M.R. lock

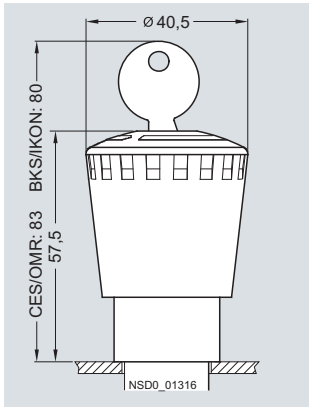

Indicator light

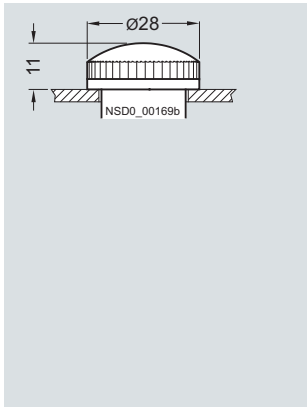

Acoustic signaling device

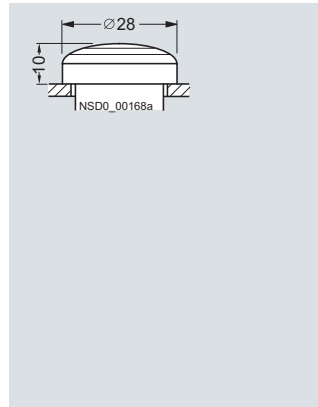

Twin pushbutton (round feed-through opening)

Twin pushbutton
 with flat buttons

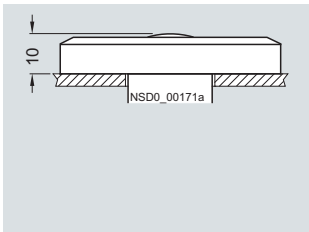

Twin pushbutton
 with raised buttons

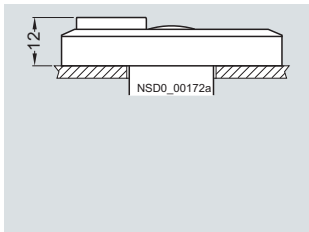

Twin pushbutton
 with or without indicator light

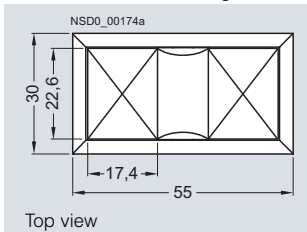

Accessories for plastic version, round

Holder

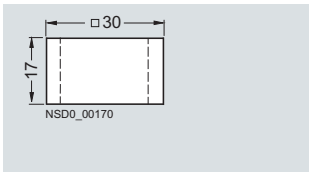

Blanking plug

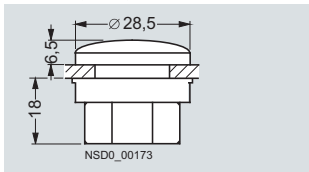

3SB3 Pushbuttons and Indicator Lights, 22 mm

Project planning aids

Plastic version, square 26 mm x 26 mm

Pushbutton, pressure switch, illuminated pushbutton or illuminated pressure switch with flat button

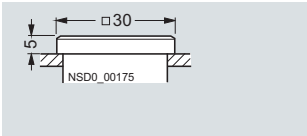

Pushbutton with raised front ring

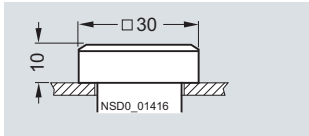

Pushbutton with raised front ring, castellated

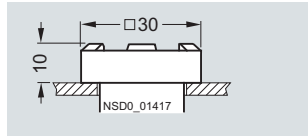

Indicator light

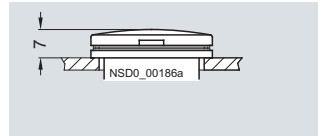

Selector switch or illuminated selector switch

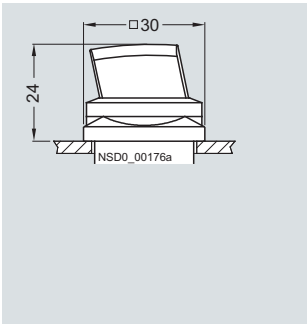

RONIS key-operated switch

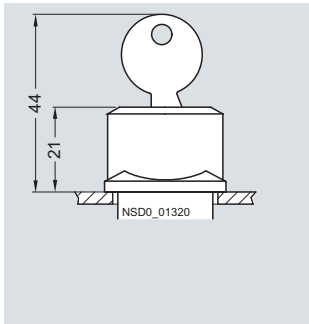

CES, BKS, O.M.R. key-operated switch

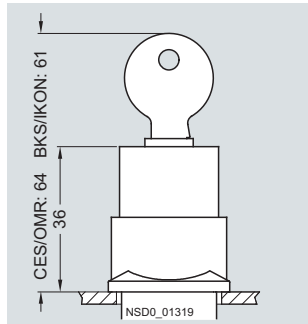

EMERGENCY-STOP mushroom pushbutton with rotate-to-unlatch mechanism

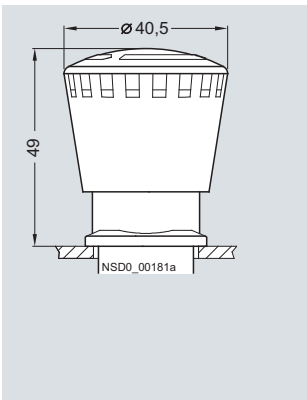

EMERGENCY-STOP mushroom pushbutton with RONIS lock

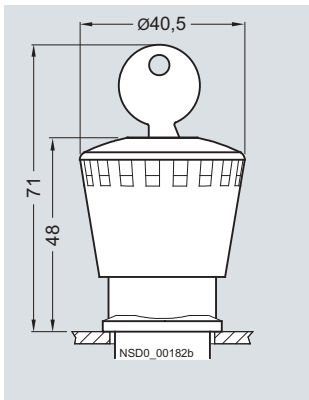

EMERGENCY-STOP mushroom pushbutton with BKS, CES, O.M.R. lock

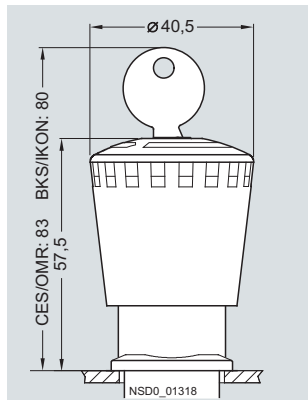

Accessories for plastic version, square

Holder

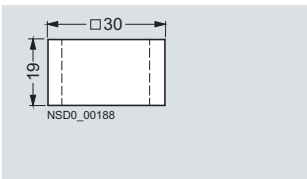

Blanking plug

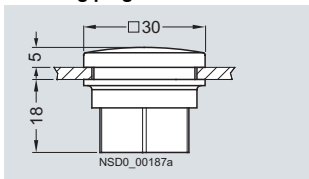

3SB3 Pushbuttons and Indicator Lights, 22 mm

Project planning aids

Metal version, round

Pushbutton or illuminated pushbutton with flat button

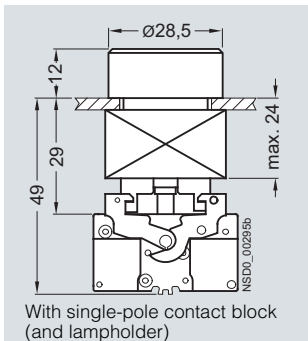

With single-pole contact block (and lampholder)

Pushbutton or illuminated pushbutton with raised button

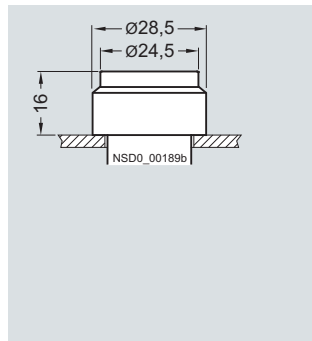

Pushbutton or illuminated pushbutton, latching, with flat button

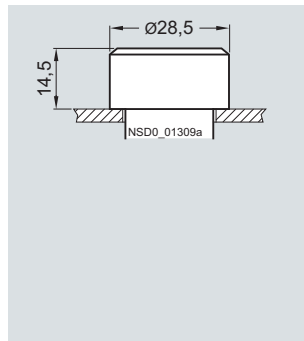

Pushbutton with raised front ring

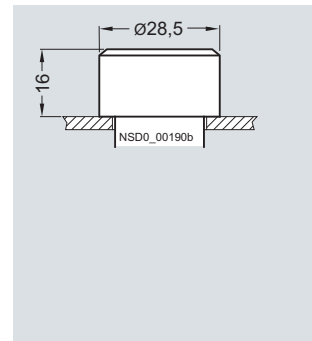

Selector switch or illuminated selector switch, standard

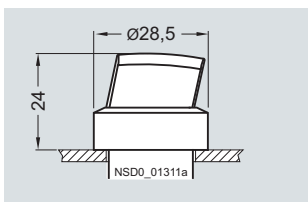

Mushroom pushbutton, illuminated mushroom pushbutton, push-pull button or illuminated push-pull button, Ø 30 mm

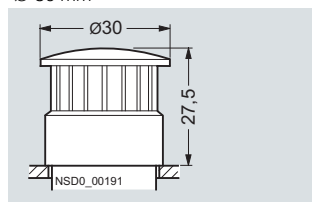

Mushroom pushbutton, illuminated mushroom pushbutton, push-pull button or illuminated push-pull button, Ø 40 mm

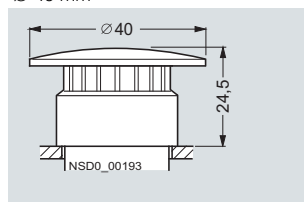

Mushroom pushbutton, illuminated mushroom pushbutton, push-pull button or illuminated push-pull button, Ø 60 mm

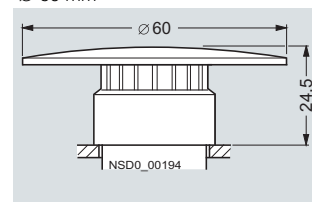

Selector switch or illuminated selector switch, heavy duty

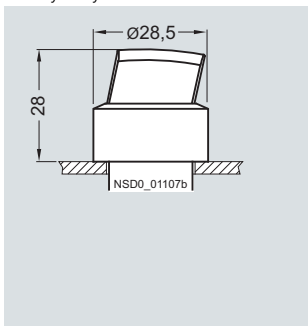

Selector switch or illuminated selector switch, with long handle

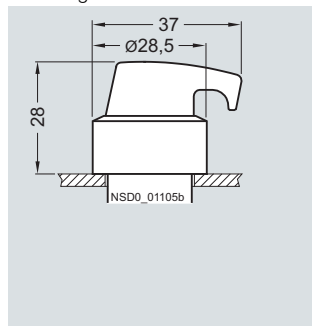

RONIS key-operated switch

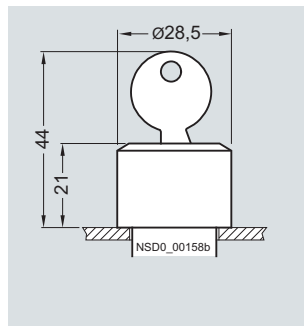

BKS, CES, O.M.R. key-operated switch

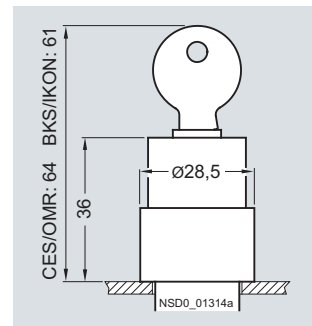

EMERGENCY-STOP mushroom pushbutton, Ø 32 mm, with rotate-to-unlatch mechanism

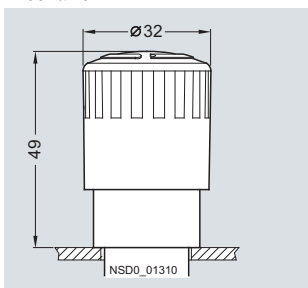

EMERGENCY-STOP mushroom pushbutton, Ø 40 mm, with pull-to-unlatch mechanism

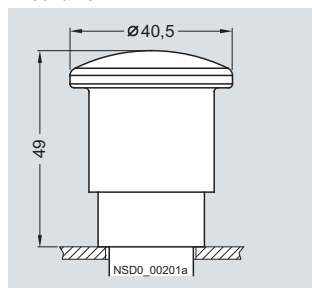

EMERGENCY-STOP mushroom pushbutton, Ø 40 mm, with rotate-to-unlatch mechanism

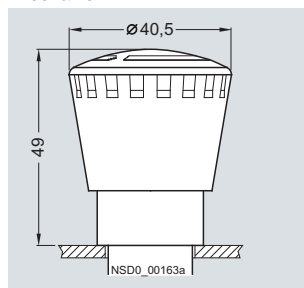

EMERGENCY-STOP mushroom pushbutton, Ø 60 mm, with rotate-to-unlatch mechanism

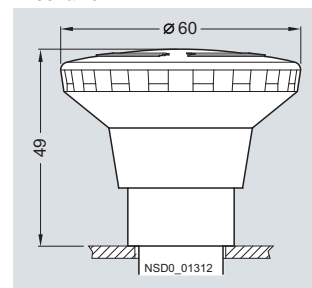

3SB3 Pushbuttons and Indicator Lights, 22 mm

Project planning aids

Metal version, round

EMERGENCY-STOP mushroom pushbutton
with RONIS lock

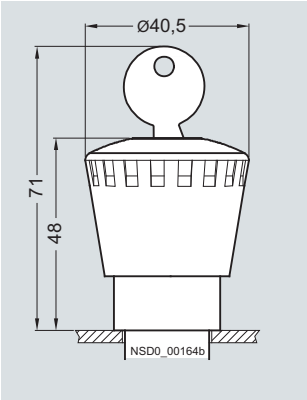

EMERGENCY-STOP mushroom pushbutton
with BKS, CES, O.M.R. lock

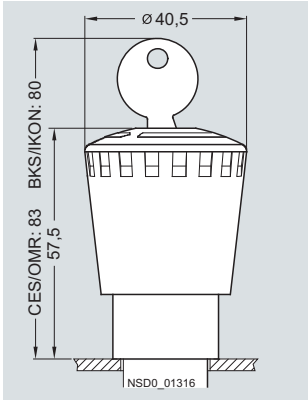

Indicator light

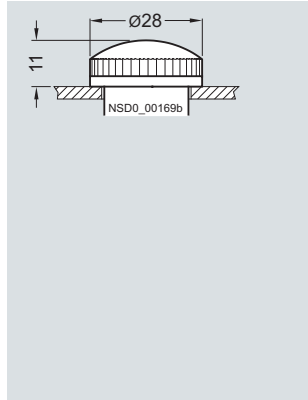

Accessories for metal version, round

Holder

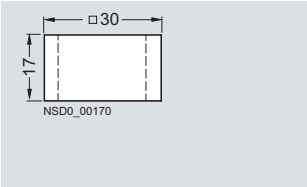

Blanking plug

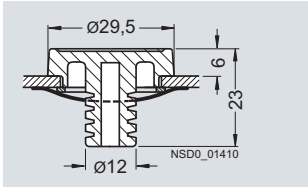

Contact blocks and lampholders

Blocks with solder pins, for use on PCB

Pushbutton with contact block with 1 contact and PCB holder

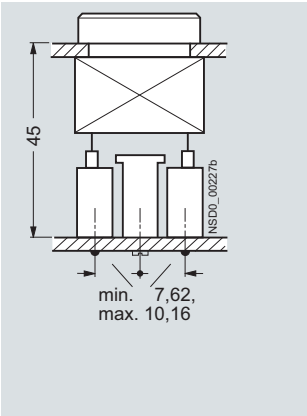

Solder pin spacing

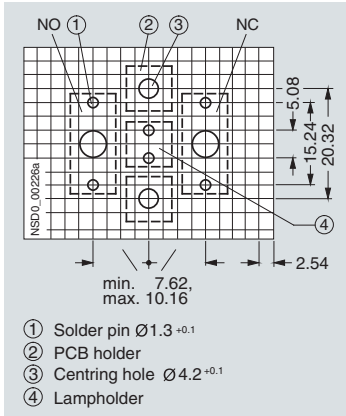

Contact block with 1 contact

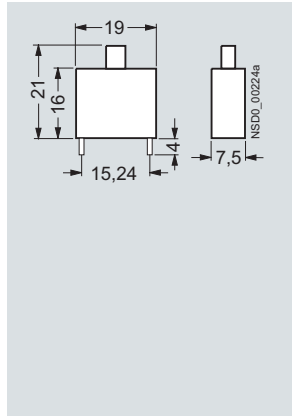

Lampholder Wedge base W2 x 4.6 d

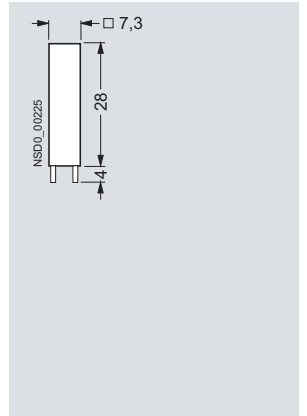

3SB3 Pushbuttons and Indicator Lights, 22 mm

Project planning aids

Contact blocks and lampholders

Blocks with screw terminals for front plate mounting

Pushbutton or illuminated pushbutton with contact blocks with 1 contact

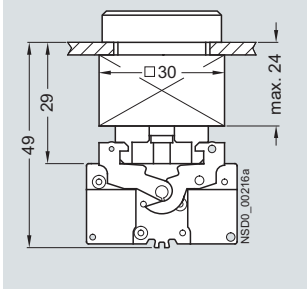

Pushbutton with contact blocks with 1 contact

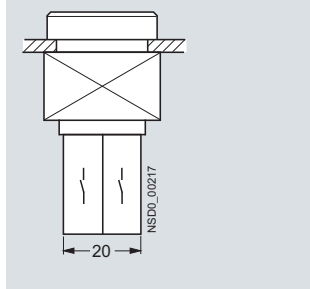

Illuminated pushbutton with contact blocks with 1 contact and lampholder

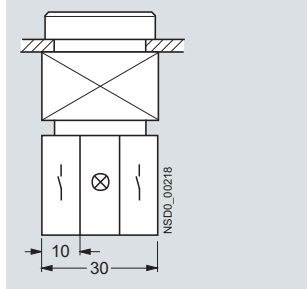

Contact block with 1 contact

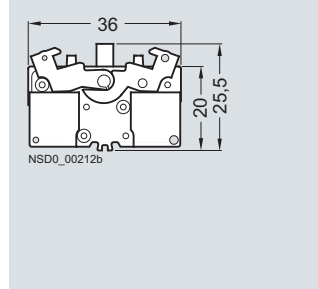

Pushbutton or illuminated pushbutton with contact blocks with 2 contacts

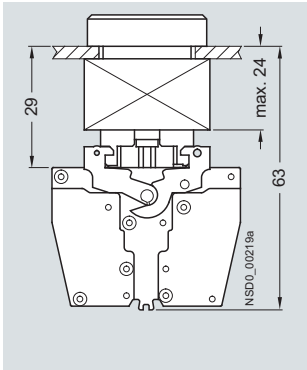

Illuminated pushbutton with contact blocks with 2 contacts and lampholder

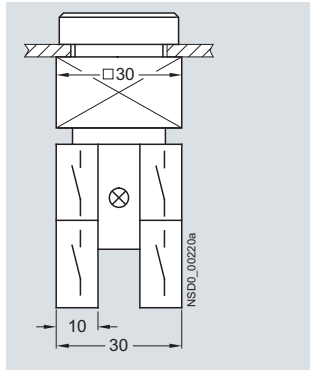

Contact block with 2 contacts, diode element

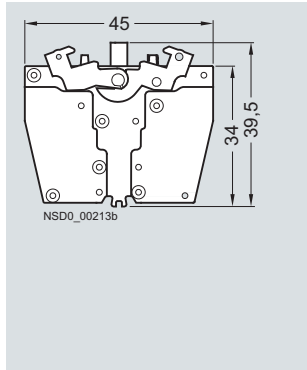

Contact block with 1 contact and mounting monitoring contact

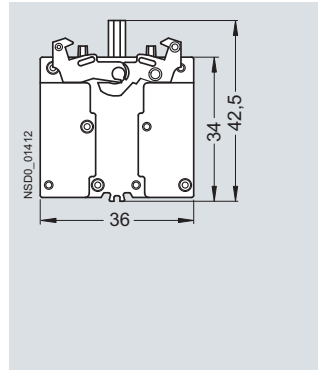

Illuminated pushbutton with contact blocks with 1 contact and lampholder with snapped-on transformer

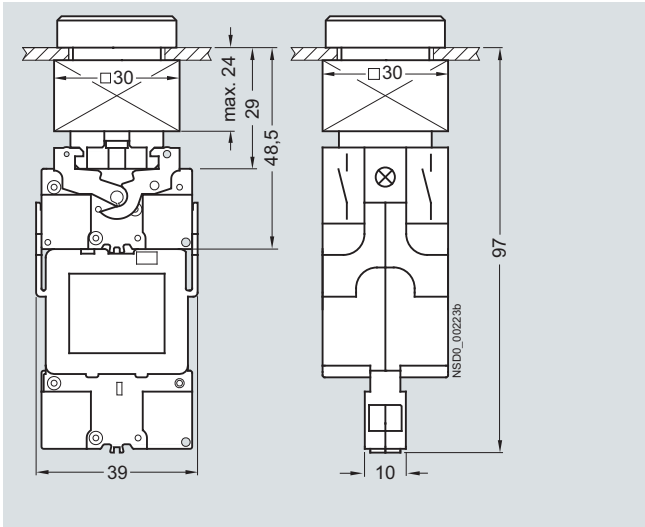

Lampholder with integrated LED

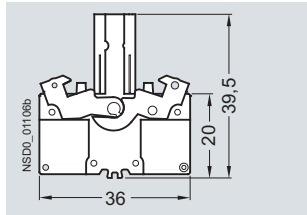

BA 9s lampholder without or with integrated voltage reducer

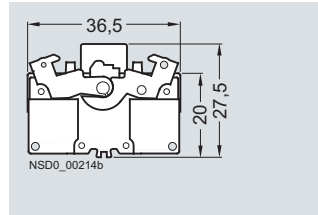

BA 9s lampholder with separate lamp test function

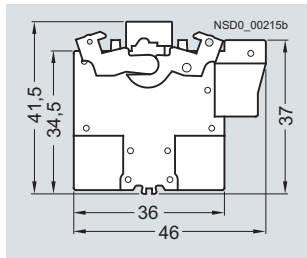

3SB3 Pushbuttons and Indicator Lights, 22 mm

Project planning aids

Contact blocks and lampholders

Blocks with spring-type terminals for front plate mounting

Contact block with 1 contact

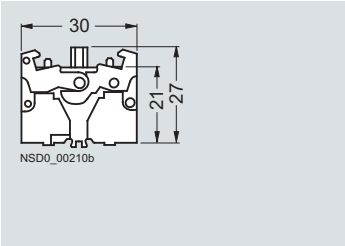

Contact block with 2 contacts

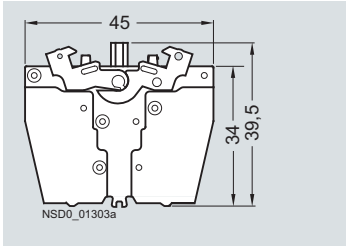

Contact block with 1 contact and mounting monitoring contact

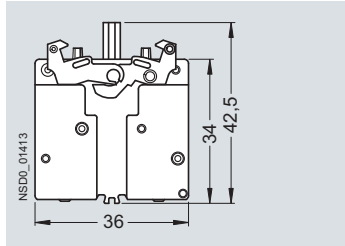

BA 9s lampholder

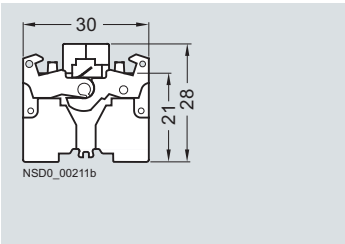

Lampholder with integrated LED

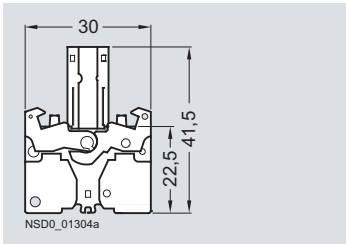

AS-Interface F adapter · Holder for mounting 3 elements

AS-Interface F adapter for EMERGENCY-STOP mushroom pushbuttons

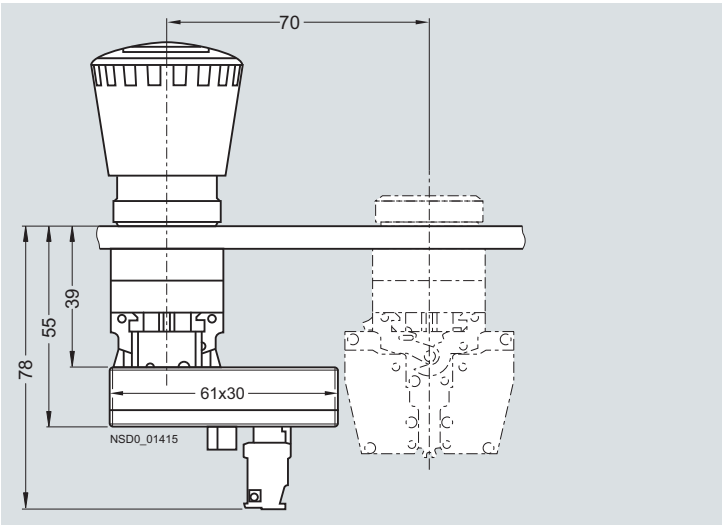

Holder for pushbuttons

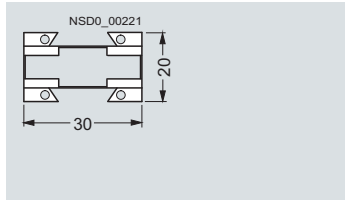

Holder for selector switch, key-operated switch and twin pushbutton, with pressure plate

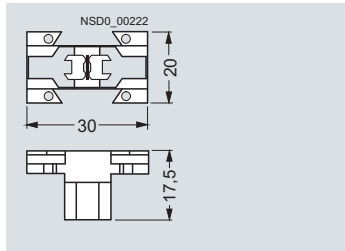

Accessories for front plates

3SB39 21-0AK, -0AP protective collar
For EMERGENCY-STOP mushroom pushbuttons without lock
For front plate mounting¹⁾

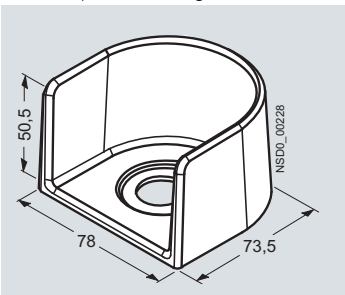

3SB39 21-0AX protective collar
For EMERGENCY-STOP mushroom pushbuttons with lock
For front plate mounting¹⁾

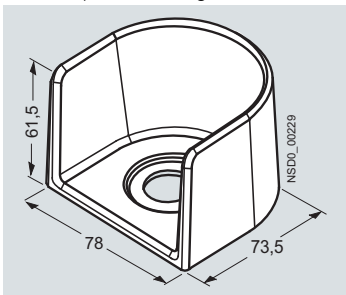

3SB39 21-0CG protective collar
For mushroom pushbuttons, for 5 padlocks
For front plate mounting¹⁾

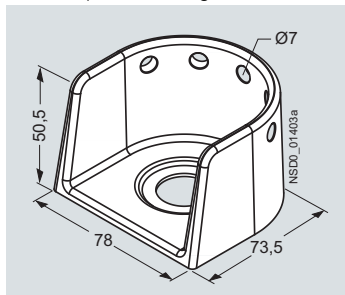

¹⁾ Can be used with a front plate thickness up to 4 mm.

Enclosures

Enclosure without protective collar, plastic

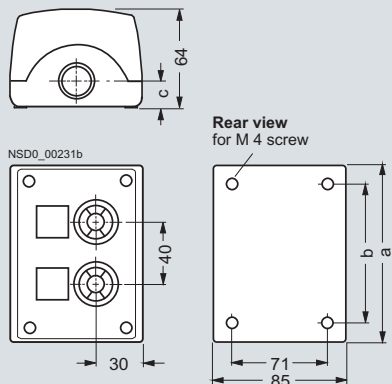

top and bottom with knockouts for one gland each

Number of command points	Length a	Distance b	Distance c
1	85	54	17.5
2	114	83	17.5
3	154	123	17.5
4	194	163	17.5
6	280	249	20.5

Enclosure without protective collar, metal

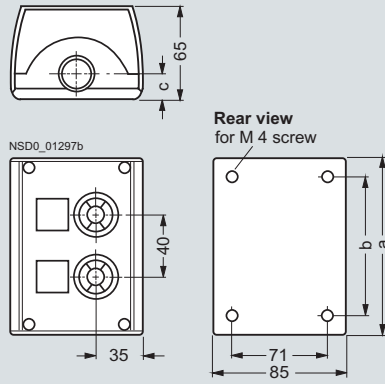

top and bottom with opening for one gland each

Number of command points	Length a	Distance b	Distance c
1	85	54	21
2	114	83	21
3	154	123	21
4	194	163	21
6	280	249	21

Enclosure with handle, metal

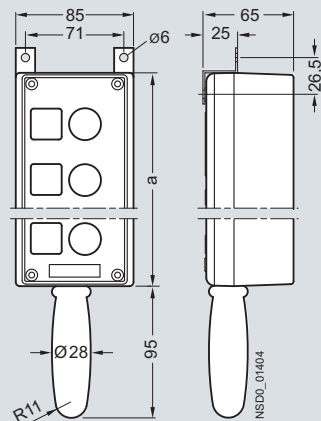

Number of command points	Length a
1	84
2	113
3	154
4	193
6	280

Enclosure with protective collar, plastic

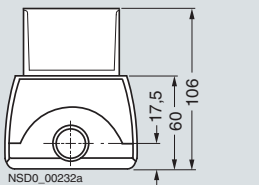

top and bottom with knockouts for one gland each

Enclosure with protective collar, metal

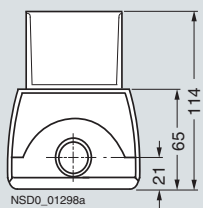

top and bottom with opening for one gland each

Enclosure with protective collar for 3 padlocks, metal

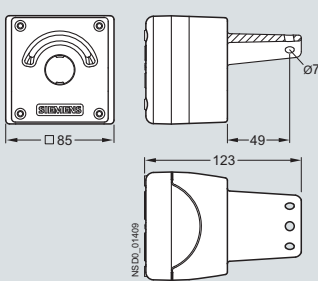

Blocks with screw terminals for floor mounting

Contact block with 1 contact

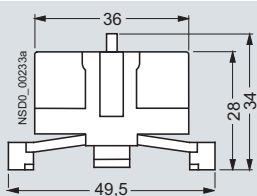

BA 9s lampholder without or with integrated voltage reducer

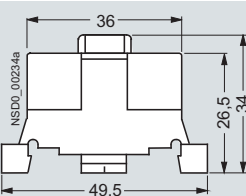

Lampholder with integrated LED

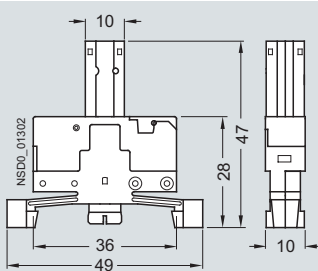

Blocks with spring-type terminals, for floor mounting

Contact block with 1 contact

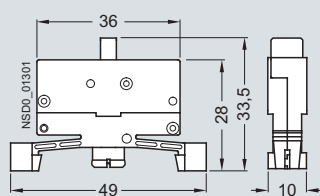

Lampholder with integrated LED

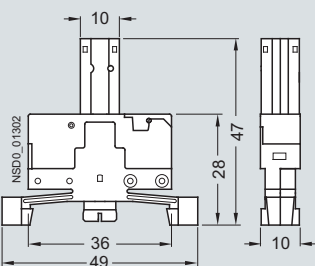

Fixpoint terminal

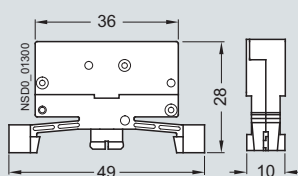

3SB3 Pushbuttons and Indicator Lights, 22 mm

Project planning aids

Schematics

Application examples of test circuits

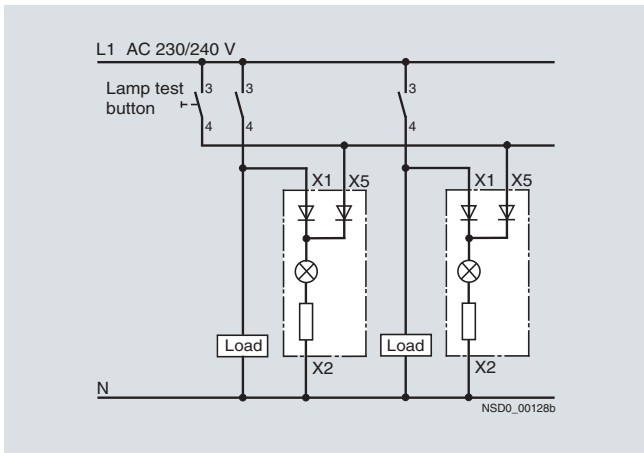

3SB34 00-1F lampholder
incl. 130 V incandescent lamp

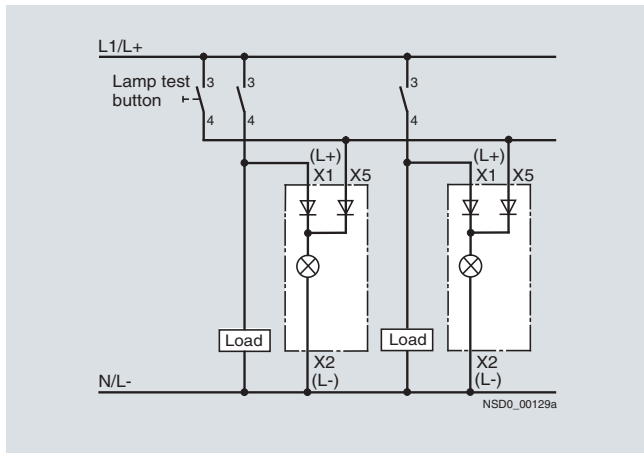

3SB34 00-1G lampholder
for incandescent lamps, maximum 2.6 W or LED lamps, AC/DC

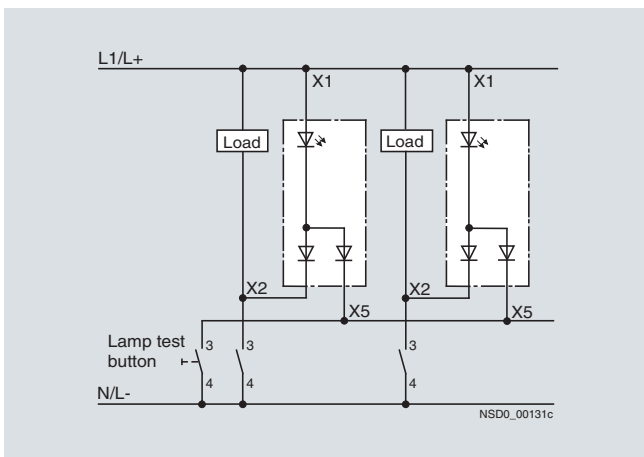

3SB34 00-1L lampholder
for incandescent lamps, maximum 2.6 W or LED lamps, AC or DC

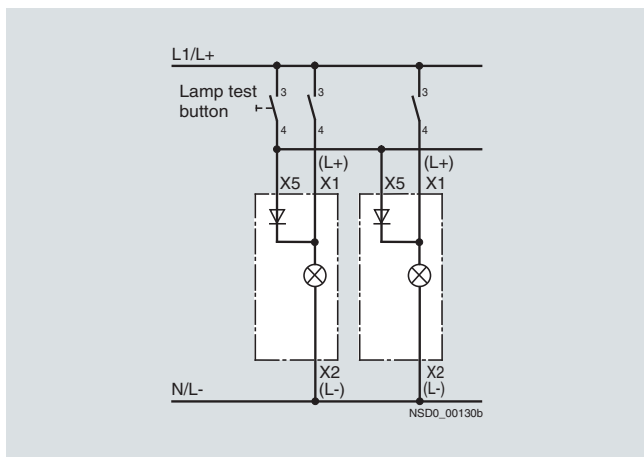

3SB34 00-1H lampholder
for incandescent lamps, maximum 2.6 W or glow lamps, AC

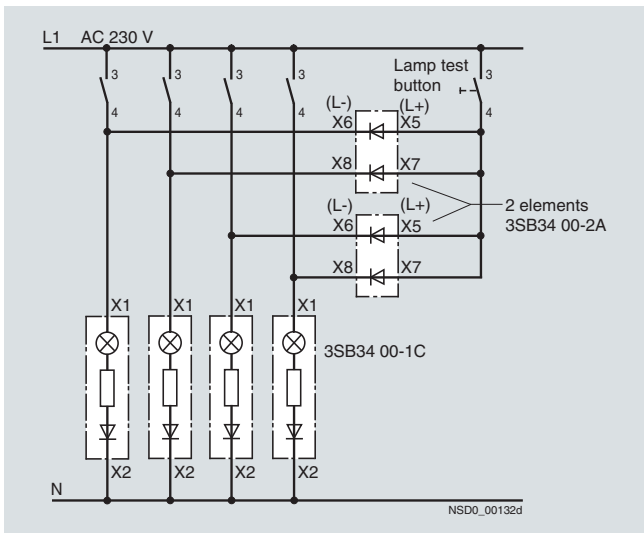

Example for lamp test circuit with 3SB34 00-2A element

Application examples for 3SB34 00-2A diode elements

- Lamp test circuit
- Interference suppression
- Limiting voltage peaks
- Limiting DC coils
- Diode gates
- Rectifier circuits

The diode element contains two 1N 4007 diodes. The element can be snapped onto the holder as required.

Notes on using the lampholders with separate lamp test function

For connecting inductive loads in parallel (e. g. contactors), overvoltage damping is necessary.

The 3SB34 00-1H element is not suitable for operation with a parallel load.

9

Overview



Two-hand operation console with metal enclosure

The two-hand operation consoles are required for use with machines and systems that have hazardous areas, in order to direct both hands of the operator to one position.

Standards

The two-hand operation consoles comply with the requirements of EN 574.

For technical specifications, see 3SB3 Pushbuttons.

Design

Equipment

The two-hand operation consoles are pre-equipped with 3SB3 command devices. In the case of plastic enclosures the command points are equipped as standard with actuators and indicators made of plastic, in the case of metal enclosures they are equipped with actuators and indicators made of metal.

The standard equipment comprises:

- 2 black mushroom pushbuttons, Ø 40 mm, 1 NO + 1 NC, Order No. 3SB30 00-1GA11 or 3SB35 00-1GA11
- 1 red EMERGENCY-STOP mushroom pushbutton according to EN ISO 13850, Ø 40 mm, with positive latching, 2 NC, Order No. 3SB30 00-1HA20 or 3SB35 00-1HA20

The metal version is also available as an unequipped empty enclosure.

The plastic version can be retrofitted with up to 8 customized command points. The surface of the console has premachined breaking points for this purpose.

Mounting

The two-hand operation consoles can be mounted either on the stand available or directly on the machine by means of the holes in the rear panel.

Function

The control command is given by pressing the two mushroom pushbuttons on the sides simultaneously (within 0.5 s of each other) and must be maintained for as long as a hazard exists.

For evaluation of the control commands, the associated 3TK28 34 press control devices are offered as two-hand control devices and the 3TK28 35 is offered as a slowing down test apparatus in relay design (see [Safety Relays in Chapter 7](#)).

Dimensional drawings

3SB38 63-1 operator panel with plastic enclosure

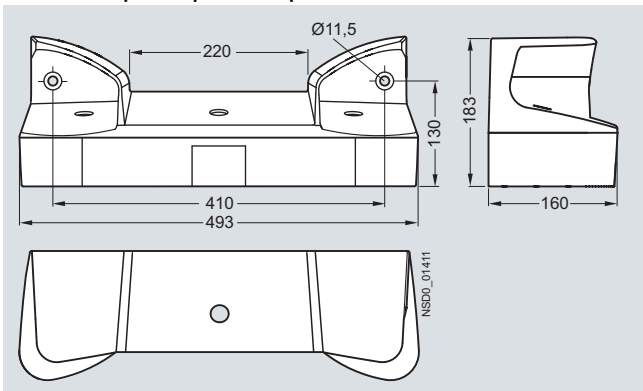

3SB39 01-0AQ3 stand

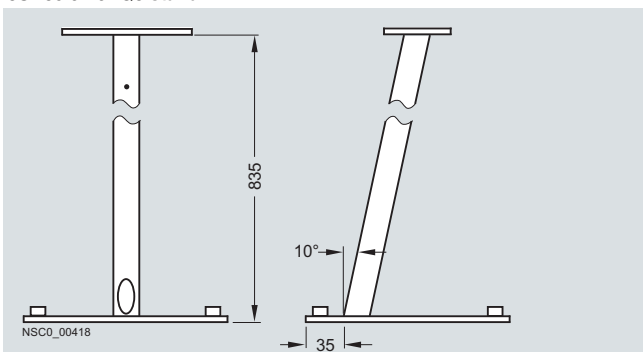

3SB38 63-4 operator panel with metal enclosure

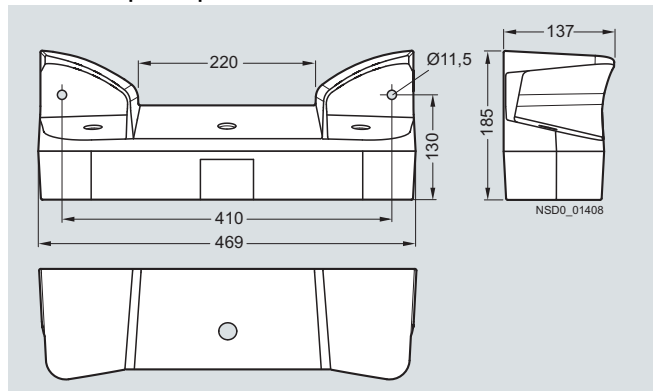

3SE7 Cable-Operated Switches

Metal enclosures

Overview



SIRIUS cable-operated switches (trip-wire switches) are used for monitoring or for EMERGENCY-STOP devices on particularly endangered system sections.

As the effective range of a cable-operated switch is only limited by the length of the trip-wire, large systems can also be protected. Cable-operated switches (requiring pulling at both ends) and conveyor belt unbalance trackers are used primarily for monitoring very long belt systems.

Standards

The switches are equipped with positive latching and positive NC contacts and are thus suitable for operation in EMERGENCY-STOP devices in accordance with EN ISO 13850.

Design

The switches for wire lengths up to 50 m are available with 1 NO + 1 NC or 2 NC contacts and for up to 75 m with 1 NO + 3 NC contacts. The switches for wire lengths of 2 × 75 m and the conveyor belt unbalance trackers are supplied with 2 NO + 2 NC contacts.

The cable-operated switch and the conveyor belt unbalance tracker can also be supplied with a factory-fitted LED (red, 24 V DC). This light in innovative on-board chip technology allows the operating state of the switch to be visible at a distance of at least 50 m.

Function

The NC contacts of the cable-operated switch and the conveyor belt unbalance tracker are positive opening.

Cable-operated switches with one-side operation are held in free position by the pre-tension on the turnbuckle.

In the 3SE7 140 and 3SE7 150 cable-operated switches, both switching contacts are available for wire-break/wire-pull signaling. The NO contact can be used, for example, for signaling purposes.

On switches with interlocking, with a pretensioned wire, the locking must be deactivated beforehand in order to return the cable-operated switch to its original position.

Technical specifications

Type		3SE7 120	3SE7 150	3SE7 140	3SE7 141	3SE7 160	3SE7 310
General data							
Standards		IEC 60947-5-1, EN 60947-5-1; IEC 60204-1, EN 60204-1; EN ISO 13850					
Approvals		UL/CSA					
Electrical design		Contacts electrically isolated from each other					
Electrical load		<ul style="list-style-type: none"> At AC-15 Min. 					
		400 V AC, 6 A			250 V AC, 2 A	400 V AC, 6 A	
		24 V AC/DC, 10 mA					
Short-circuit protection	A	6 (slow)					
Mechanical endurance		> 1 million operating cycles					
Contact material		Fine silver					
Operation		By pulling or breaking of the wire					
Wire length, maximum	m	10	25	50	75	2 × 75	–
Distance between wire supports, max.	m	2.5	3	5			–
Enclosure							
Enclosure material		GD Al alloy, coated (color), dark black RAL 9005					
Cover		Shock-resistant thermoplast					
Degree of protection acc. to EN 60529		IP65			IP67	IP65	
Ambient temperature	°C	–25 ... +70					
Mounting		Designed for M5					
Fixing spacing	mm	30 and 40					
Cable entry		2 × (M20 × 1.5)		1 × (M16 × 1.5)	3 × (M20 × 1.5)	2 × (M25 × 1.5)	
Connection type		Screw terminals M3.5, self-lifting clamp terminal					

Configuration

Mounting and fixing the wire

Short lengths of the wire up to 25 m

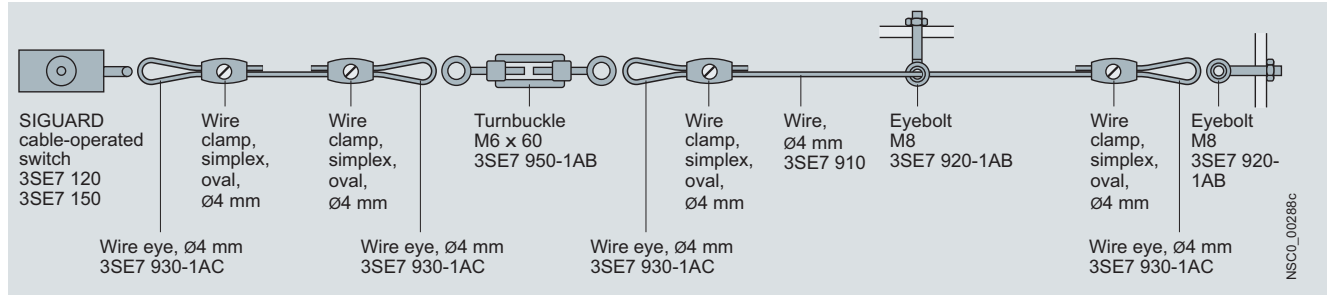

Long lengths of the wire up to 50 m

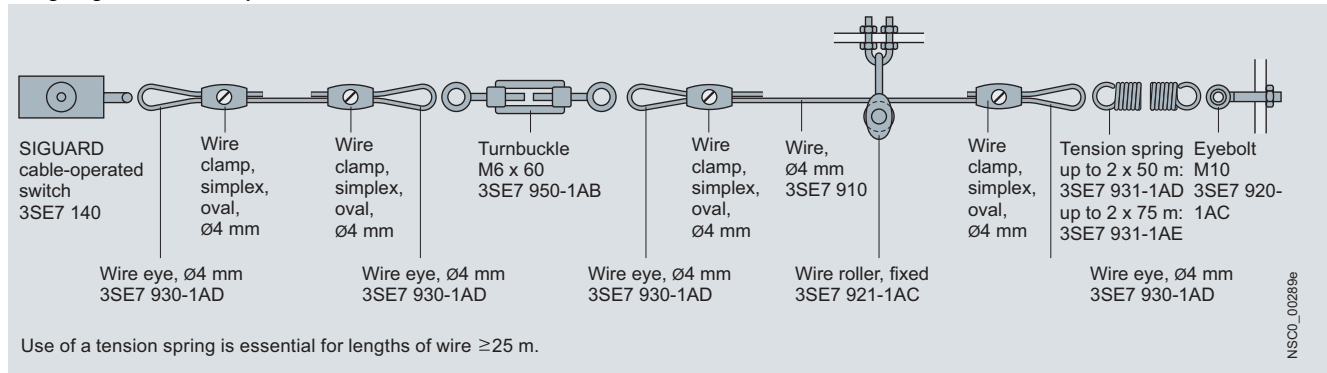

Pulling from both sides up to 2 x 75 m

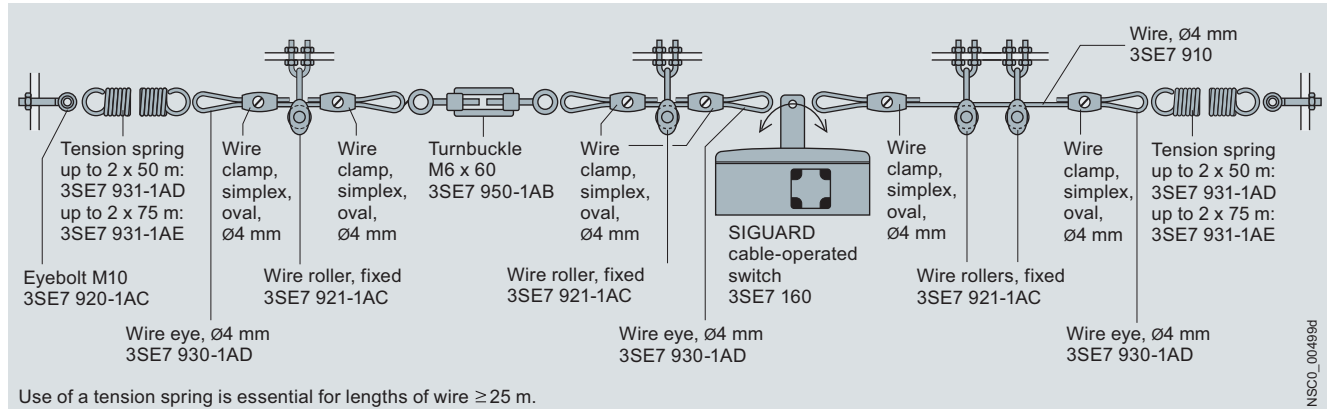

Preloading and actuating forces

The values quoted apply to switch mounting at an ambient temperature of 20 °C. No allowance is made for lengthening of the wire through stretching and deformation of the wire eye.

Type	Preloading force N	Operating distance cm	Actuating force ¹⁾ N	Max. wire length m
3SE7 120	55	11	6	10
3SE7 150	200	11	25	25
3SE7 140	295 ... 390	13	38 ... 60	50
3SE7 141	100	20 ... 22	28 ... 34	75
3SE7 160	--	32 ... 40	45 ... 85	2 x 75

¹⁾ The actuating forces quoted are only guide values because the spring forces are subject to tolerances.

3SE7 Cable-Operated Switches

Metal enclosures

Dimensional drawings

3SE7 120-2DD.., 3SE7 150-2DD..
without latching

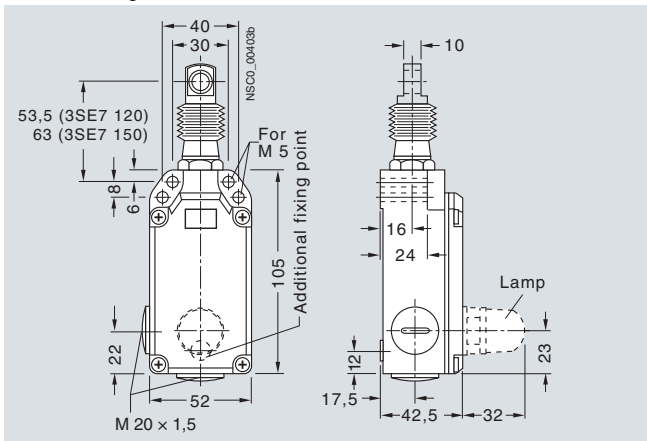

3SE7 120-1B..., 3SE7 150-1B...
with latching and button reset

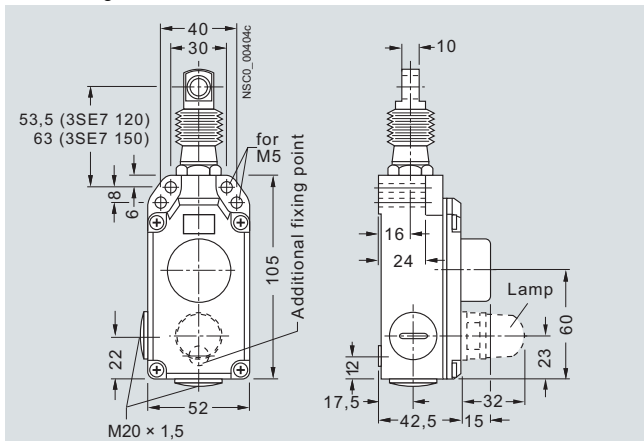

3SE7 150-1CD..
with latching, button reset and key unlatching

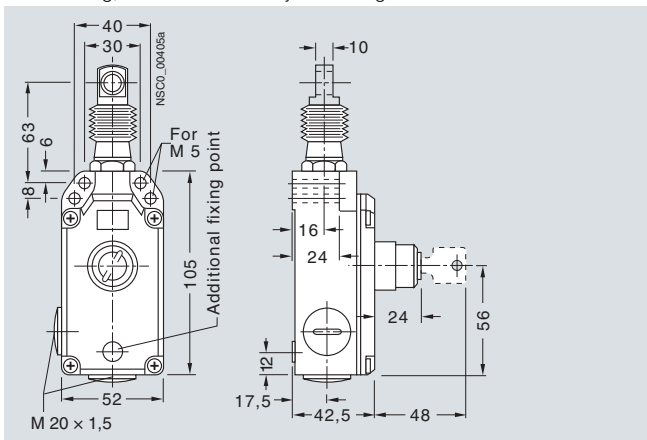

3SE7 141-1EG..
with EMERGENCY STOP and rotate-to-unlatch mechanism

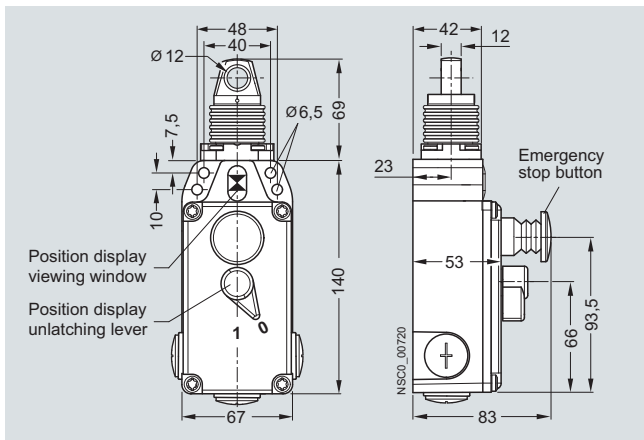

3SE7 140-1B...
with latching and button reset

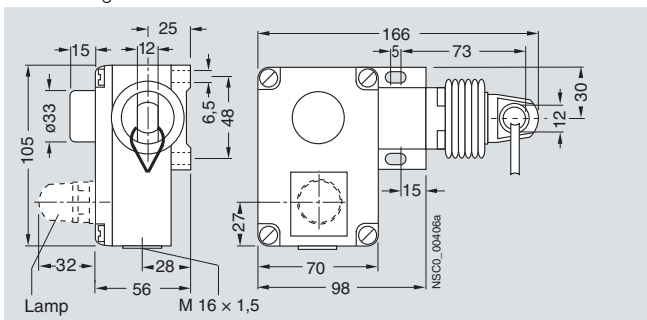

3SE7 140-1CD..
with latching, button reset and key unlatching

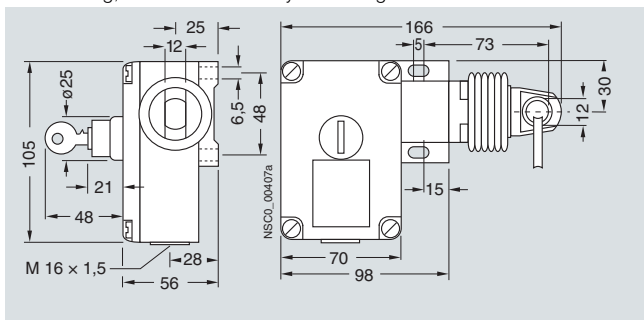

3SE7 160-1AE..
with latching and button reset

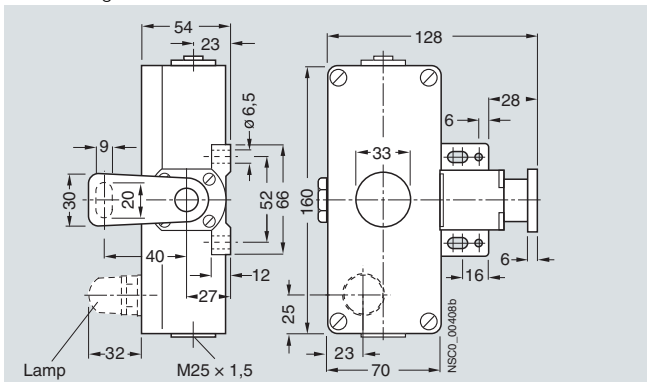

3SE7 160-1BD..
with latching and button reset

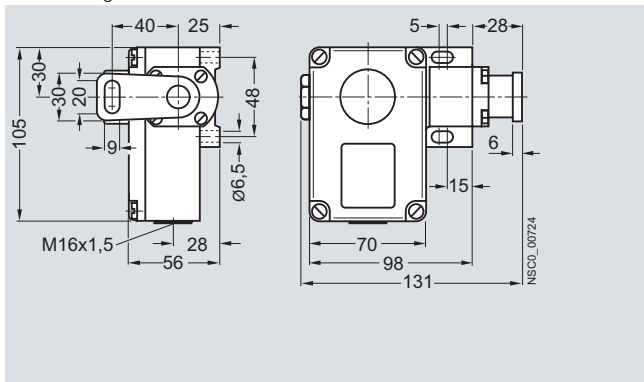

9

3SE7 310-1AE.. conveyor belt unbalance tracker
with latching and button reset

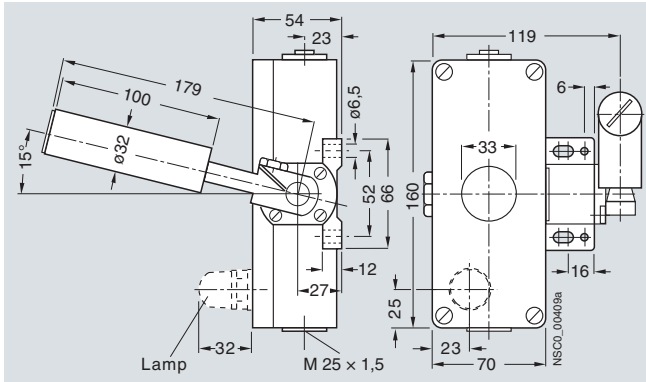

Schematics

Connection diagrams, operating travel diagrams

3SE7 120-2DD01

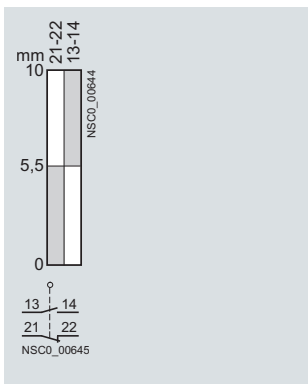

**3SE7 150-1.D00,
3SE7 150-2DD00**

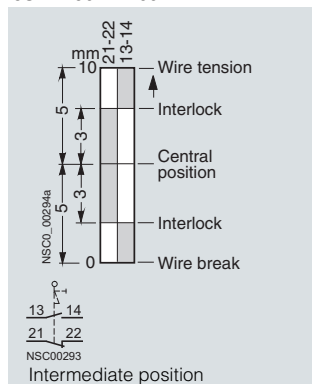

**3SE7 120-1BF00,
3SE7 150-1BF00**

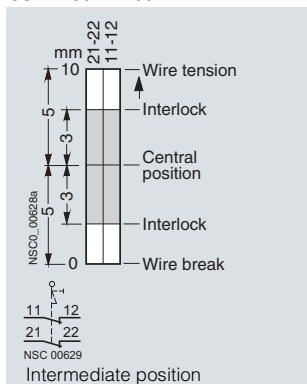

3SE7 140-1.D0.

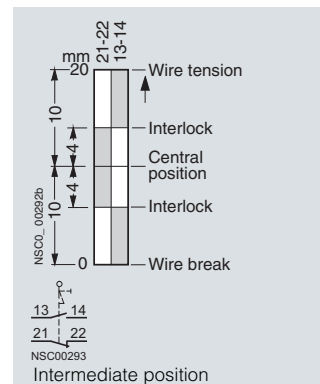

3SE7 140-1BF00

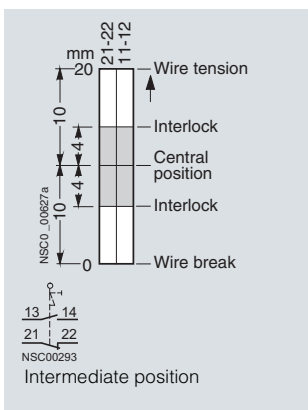

3SE7 141-1EG10

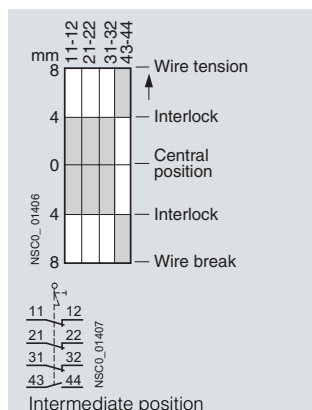

3SE7 160-1BD00

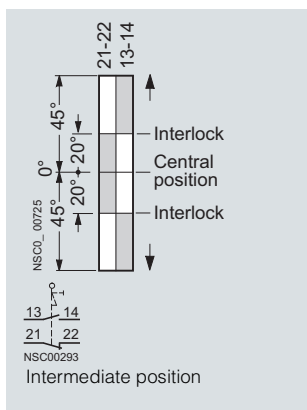

**3SE7 160-1AE0.,
3SE7 310-1AE0.**

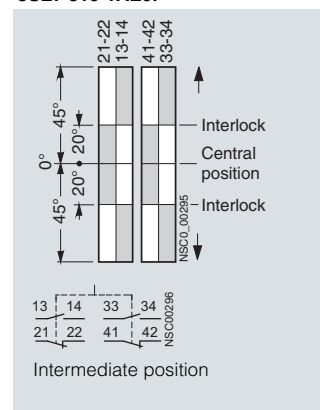

- Contact closed
- Contact open

3SE2, 3SE3 Foot Switches

Plastic and metal enclosures

Overview

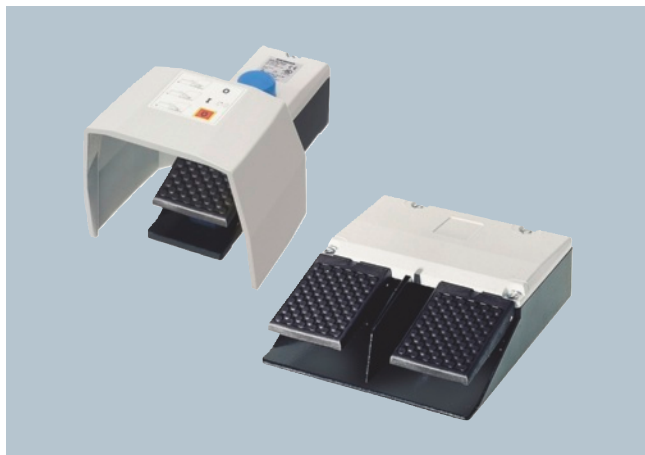

Foot switches with metal enclosures

The 3SE2 9 and 3SE3 9 foot switch range encompasses versions in a metal enclosure for rugged applications as well as

versions with plastic enclosure. The devices can be supplied with or without a cover and have fixing holes for them to be screwed to the floor.

Depending on the particular application, the switches can be ordered in latching or momentary-contact versions.

Safety foot switches

The single-pedal safety foot switches according to EN ISO 13850 lock on actuation. After eliminating the hazard, the machine can only be restarted after manually releasing the switch. A pushbutton on the top of the enclosure is used for this purpose. The devices are supplied with a cover.

Version with plastic enclosure

For operation in less harsh environments, momentary-contact pedal switches with plastic enclosures are available. They are supplied in single-pedal and two-pedal versions, the single-pedal version is also available with a cover. The momentary-contact pedal switch has one microswitch (changeover contact) per actuating pedal.

Technical specifications

Type		3SE29	3SE39
Metal and plastic enclosures			
Standards		IEC 60947-5-1	IEC 60947-5-1
Electrical load			
• At AC-15, 400 V	A	16 6 A for 3SE2903-1....	–
• At 250 V AC	A	–	5
Short-circuit protection	A	16 (slow) 6 (slow) for 3SE2903-1....	5 (slow)
Mechanical endurance		> 10 ⁶ operating cycles	> 10 ⁶ operating cycles
Material			
• Enclosure		Aluminum casting	Impact-resistant thermoplast, self-extinguishing acc. to UL 94 VO
• Cover		Thermoplast	–
• Guard hood		Aluminum casting	Metal
Degree of protection		IP65	IP65
Ambient temperature	°C	-25 ... +80	-10 ... +75
Connection		Cable entry, metric	Cable AWG20, UL Style 2464, length 3 m

Dimensional drawings

Metal enclosures

3SE2 902-0AB20, 3SE3 903-1AB20, 3SE2 912-2AB20

momentary-contact foot switch/switch, one pedal, without cover

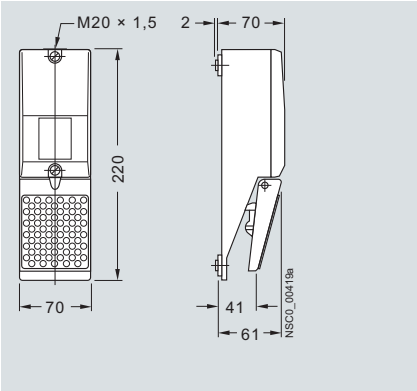
**3SE2 902-0AA20, 3SE3 903-1AA20, 3SE2 912-2AA20**

momentary-contact foot switch/switch, one pedal, with cover

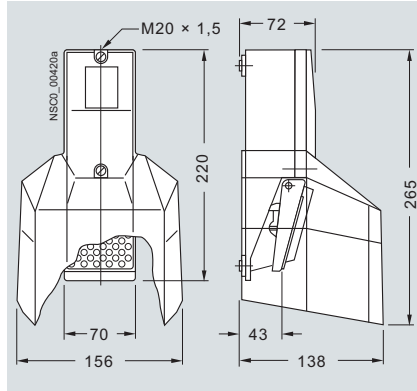
**3SE2 924-3AA20**

safety foot switch with interlock

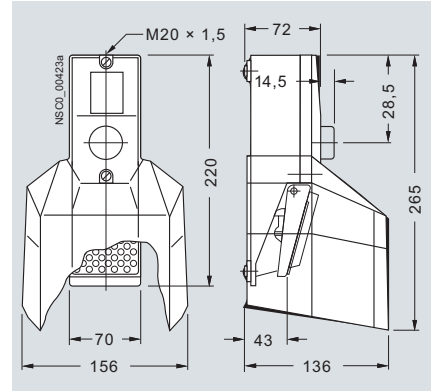
**3SE2 932-0AB20, 3SE2 932-1AB20**

momentary-contact foot switch, two pedals, without cover

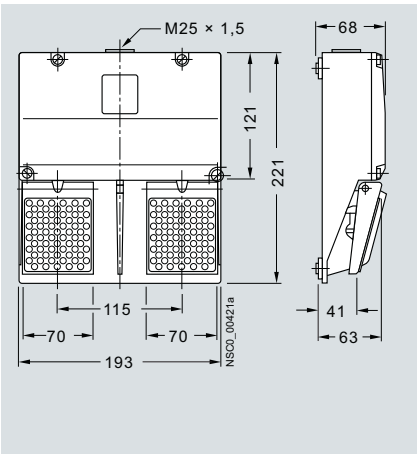
**3SE2 932-0AA20, 3SE2 932-1AA20**

momentary-contact foot switch, two pedals, with cover

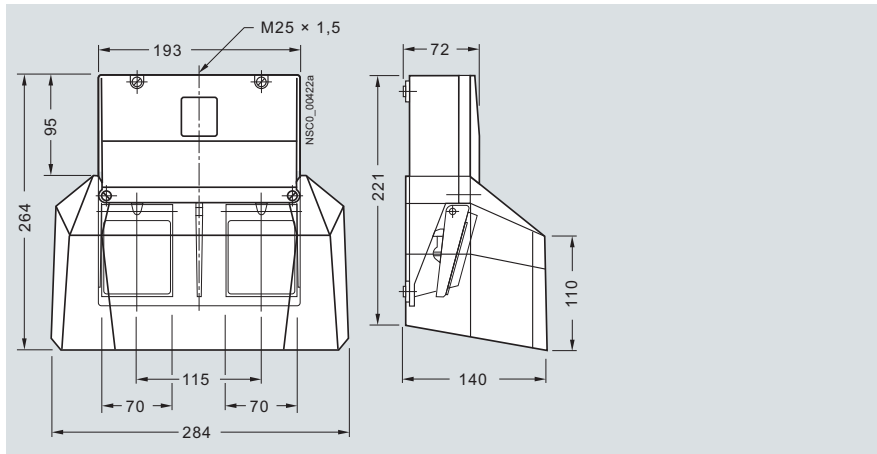

Plastic enclosures

3SE3 902-4CB20

momentary-contact pedal switch, one pedal, without cover

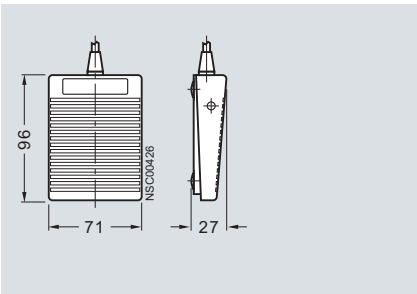
**3SE3 902-4CA20**

momentary-contact pedal switch, one pedal, with cover

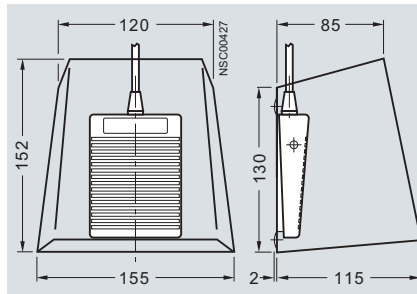
**3SE3 934-5CB20**

momentary-contact pedal switch, two pedals, without cover

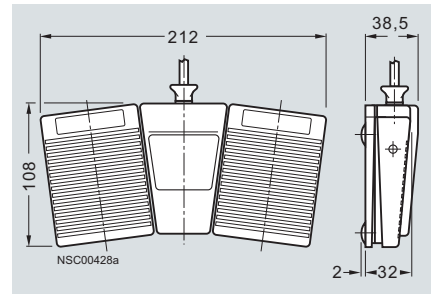

8WD4 Signaling Columns

General data

Overview

The 8WD4 signaling columns are flexible in design and versatile in use.

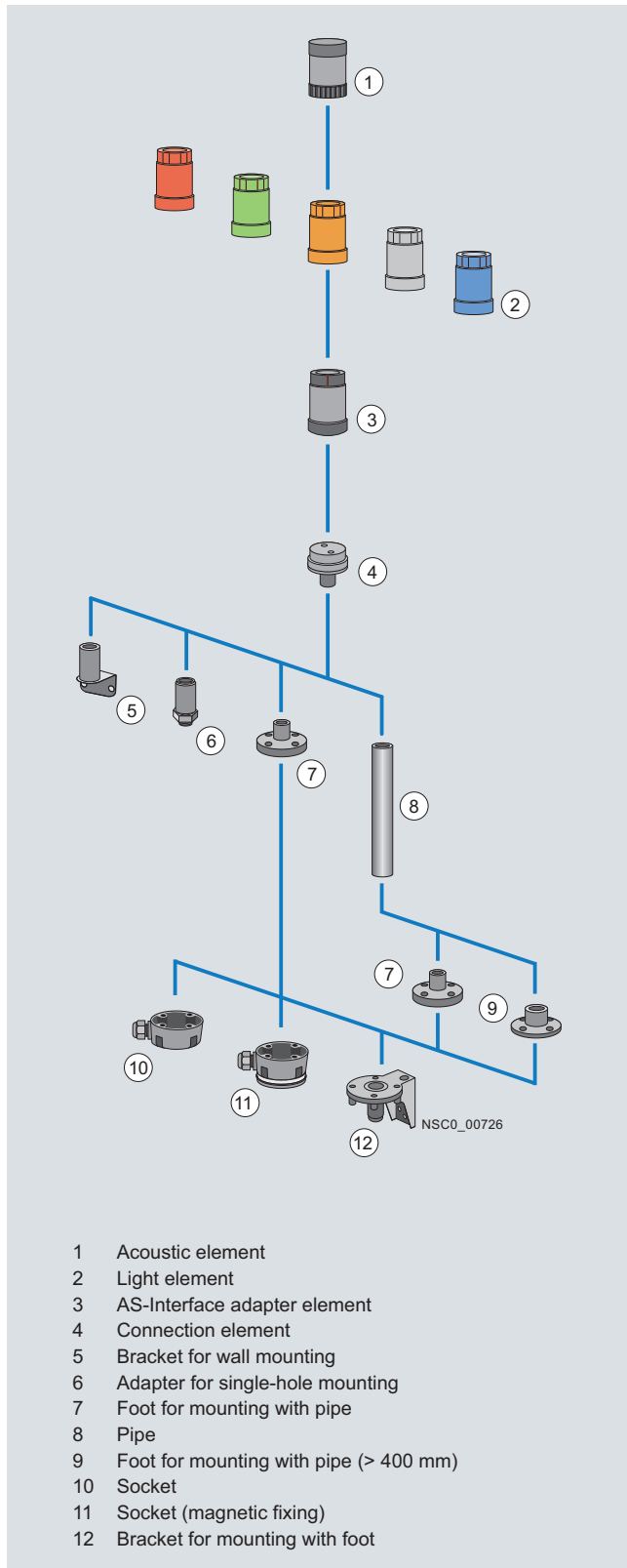

8WD42 signaling columns (width 50 mm) with up to 4 elements

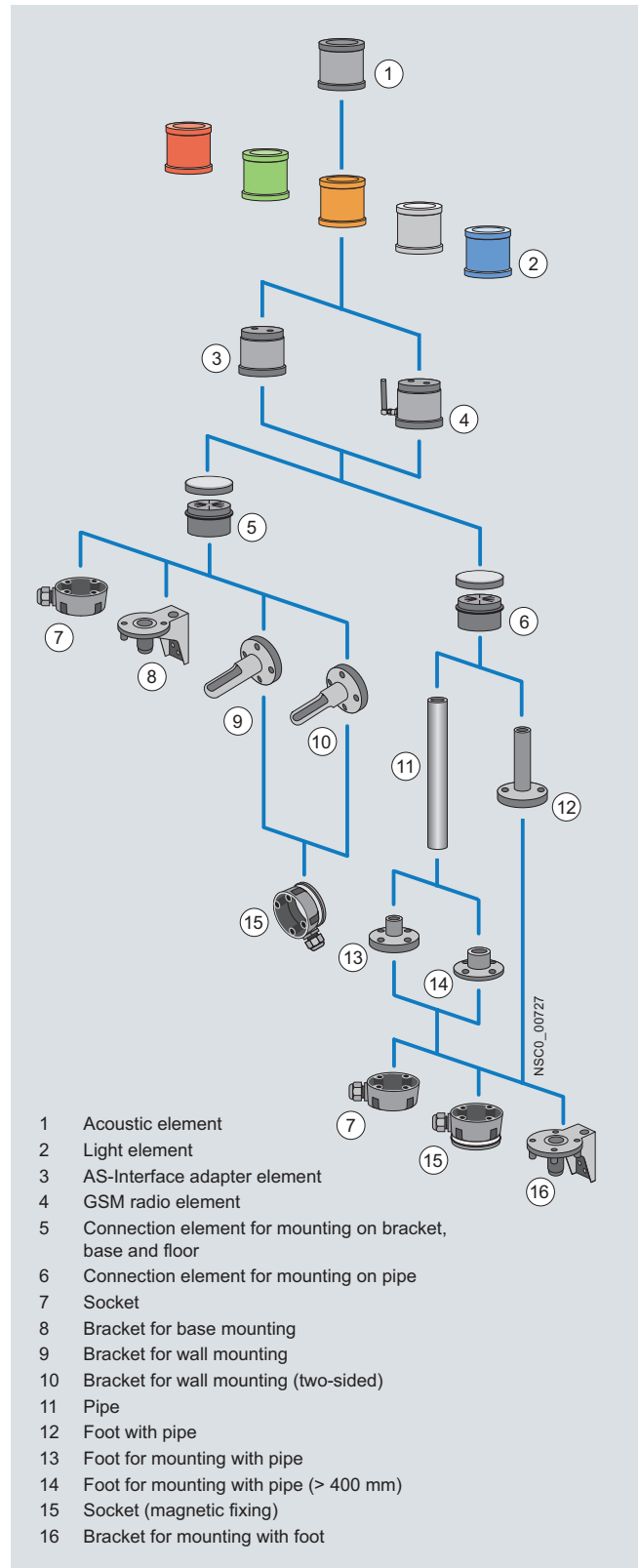

8WD44 signaling columns (width 70 mm) with up to 5 elements

Two product series are available:

- 8WD42
 - Thermoplast enclosure, diameter 50 mm
 - Degree of protection IP54
 - Up to 4 elements can be mounted
- 8WD44
 - Thermoplast enclosure, diameter 70 mm
 - Advanced design and significantly improved illumination
 - Fast and flexible connection using spring-type terminals
 - Integrated degree of protection IP65
 - Up to 5 elements can be mounted



Signaling columns, mounting examples

The illustrated examples are from the left:

- 8WD42: Cover (no No.), 4 light elements ②, connection element ④, pipe ⑧, foot ⑦
- 8WD44: Cover (no No.), acoustic element ①, 2 light elements ②, connection element ⑥, foot with pipe ⑫
- 8WD44: Cover (no No.), 4 light elements ②, GSM radio element ④, connection element ⑤, bracket for wall mounting ⑨
- 8WD44: Cover (no No.), 3 light elements ②, AS-Interface adapter element ③, connection element ⑥, foot with pipe ⑫

Note: The cover is supplied with the connection element.

Design

8WD4 signaling columns can be combined as required as modular components and are available in two diameters, 50 mm and 70 mm.

Signaling elements

The separate signaling elements are mechanically joined with a bayonet mechanism for electrical reliability and vibration resistance. Tools are not required. Up to five signaling elements (four in the case of 8WD42) can be connected to one connection element. The bracket for two-sided mounting permits, in the case of the 8WD44 signaling columns, the installation of two connection elements and therefore up to ten signaling elements in a single location.

Signaling elements are available in the following versions:

- Continuous light element (incandescent lamp, LED)
- Blinklight element (incandescent lamp, LED)
- Flashlight element
- Rotating-beacon element (LED)
- Buzzer element
- Siren element

The tone of the buzzer element can be altered as desired between a pulsating and a continuous tone by means of a wire bridge in the buzzer element.

The amplification of the siren element can be selected in the 100 dB version via an integrated potentiometer. It is possible to set 8 sounds using a DIP switch.

Mounting

Floor mounting

The 8WD42 signaling columns are mounted on the floor with a 8WD42 08-0DE plastic foot.

The 8WD44 signaling columns can be directly screwed onto the connection element for floor mounting.

Pipe mounting

Pipes are available in various lengths from 150 mm to 1000 mm. A special molded foot is recommended for pipes of more than 500 mm in length to improve stability.

Angle mounting

The supplementary component for mounting at a 90° angle, e. g. to walls, is directly attached to the connection element. A special connection element for angle mounting is required for the 8WD44 signaling columns.

Single-hole mounting

The 8WD42 signaling columns can be fixed using a drilled hole using the adapter for single-hole mounting. It is screwed in place from below.

Magnetic fixing

The adapter with the sideways cable outlet can also be ordered with magnetic fixing as a special version. This offers easy, flexible mounting on metal plates or panels which is also extremely resistant to shocks.

8WD4 Signaling Columns

General data

Connections

The signaling elements are wired up using the screw terminals in the connection element, screw terminals on the 8WD42 and screw or spring-type terminals on the 8WD44.

Cable outlet

The connecting cables can be guided either downwards or sideways through the cable gland using an adapter that can be screwed under the foot. This makes wiring easier if there is no access from below.

Connection to AS-Interface



8WD42:

The two-wire bus cable is fixed to the screw terminals in the connection element. The adapter element must be the first module to be positioned on the connection element. A maximum of 4 signaling elements can then be mounted on it.

The 8WD42 28-0BB adapter element is a standard slave.

8WD44:

The two-wire bus cable is fixed to the screw or spring-type terminals in the connection element. The adapter element must be the first module to be positioned on the connection element. The signaling elements can then be mounted on it.

The 8WD44 28-0BE adapter element is a standard slave. A maximum of 4 signaling elements can be mounted on it.

The 8WD44 28-0BD adapter element with A/B technology enables the connection of up to 62 slaves on one AS-Interface system. The addressing socket provides user-friendly parameterization of the AS-Interface elements. A maximum of 3 signaling elements can be mounted on this element.

Function

GSM radio elements

Downtimes can be minimized with the 8WD44 GSM radio element. Faults are signaled within seconds over a mobile phone from any place at any time.

The radio element is integrated below the light elements in the signaling column and can be quickly commissioned and easily operated:

- Insert SIM card in the radio element
- Call the radio element with the receiver's mobile phone
- Start the monitoring

Each module can have up to three different call numbers. In addition to using the SMS function the receiver can obtain information about the current state of the machines or plants by call, fax or e-mail service (through the provider) or he can perform remote diagnostics by mobile phone.

The alarm function of the radio element can be switched on or off at any time:

- By calling the radio element
- By sending an SMS with the corresponding commands
- By operating an input in "External Control" mode

The radio elements can also be connected to an AS-Interface module with an external power supply.

Technical specifications

Type	8WD42	8WD44
General data		
Approvals	UL, CSA	
Light and acoustic elements		
Rated voltage, power consumption		
Light elements with incandescent lamp	(AC values for 50/60 Hz)	(AC values for 50/60 Hz)
• Continuous light	12 V, 24 V, 115 V, 230 V AC/DC	12 V, 24 V, 115 V, 230 V AC/DC
• Blinklight	24 V AC/DC/125 mA; 115 V AC/20 mA; 230 V AC/15 mA	24 V AC/DC/125 mA; 115 V AC/20 mA; 230 V AC/15 mA
• Flashlight	--	24 V DC/125 mA; 115 V AC/20 mA; 230 V AC/35 mA
• Max. inrush current, blinklight/flashlight	--	500 mA
Light elements with integrated LED		
• Continuous light	24 V AC/DC/60 mA	24 V AC/DC/45 mA; 115 V AC/DC/25 mA; 230 V AC/25 mA
• Blinklight	--	24 V AC/DC/40 mA
• Rotating light	--	24 V AC/DC/70 mA
Acoustic elements		
• Buzzer element (tone: pulsating or continuous, 85 dB)	24 V AC/DC/25 mA; 115 V AC/DC/25 mA; 230 V AC/25 mA	24 V AC/DC/25 mA; 115 V AC/DC/25 mA; 230 V AC/25 mA
• Siren element (8 tones + amplification can be set, 100 dB)	--	24 V AC/DC/80 mA; 115 V AC/30 mA; 230 V AC/16 mA
• Siren element (108 dB)	--	24 V DC/100 mA
GSM radio elements	--	24 V DC (controlled $\pm 15\%$)/50 mA, transient 450 mA
Power consumption		
• Incandescent lamps, base BA 15d	W	Max. 5
• Flashlight, flash energy	Ws	--
		7
		2
Endurance		
• Flashlight	4 x 10 ⁶ flashes	4 x 10 ⁶ flashes
AS-Interface adapter elements		
IO code/ID code	8/F	8/E
Power supply		
• Operational voltage	V	Through bus cable 18.5 V ... 31.6
• Power consumption I_{\max}	mA	50
		100
Protective measures		
• Watchdog	✓	✓
• Short-circuit/overload protection	External back-up fuse M 1.6 A	✓
• Reverse polarity protection	✓	✓
• Induction protection	Does not apply	✓
Outputs		
	4 relay outputs	3 solid-state outputs
• Load voltage	External auxiliary voltage	Through bus cable or external auxiliary voltage, switch-selectable
	V	
	0 ... 30 DC	
	V	
	0 ... 230 AC	
• Current carrying capacity ΣI_{\max}		
- With external auxiliary voltage	A	1.5
- Without external auxiliary voltage	A	--
		0.3
		0.2
Operating temperature	°C	-20 ... +50
		-30 ... +50
Enclosure		
Enclosure material	Thermoplast (polyamide), impact-resistant, black	Thermoplast (polyamide), impact-resistant, black
Light elements, GSM radio element	Thermoplast (polycarbonate)	Thermoplast (polycarbonate)
Mounting		
• Horizontal (for floor mounting, foot with 25 mm Ø pipe)	✓	✓
• Horizontal (single-hole mounting)	✓	--
• Vertical with bracket	✓	✓
Degree of protection		
• Light elements	IP54	IP65 (seal premounted with every module)
• Acoustic elements, AS-i adapter elements	IP54	IP65
Operating temperature	°C	-20 ... +50
		-20 ... +50
Connection		
• Conductor cross-sections	mm ²	M3 screw terminals Max. 2.5
• Tightening torque	Nm	Spring-type terminals Max. 2.5 --

8WD4 Signaling Columns

8WD42 signaling columns, 50 mm diameter

Dimensional drawings

Signaling column (4-tier)

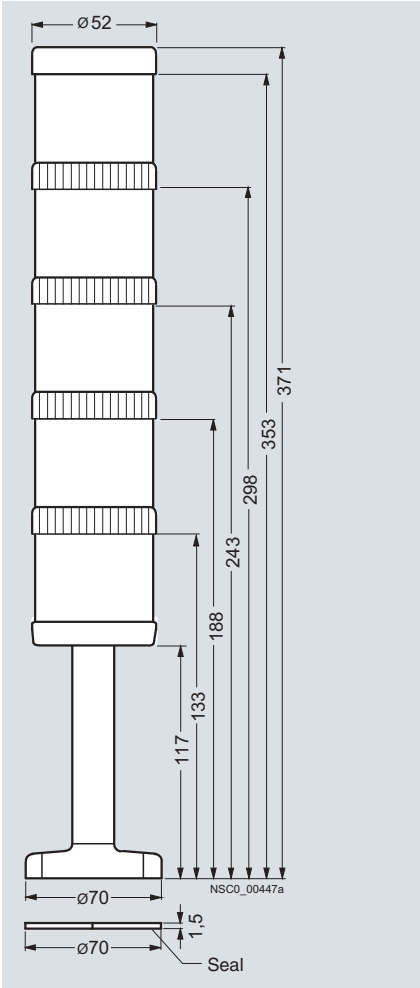

Foot

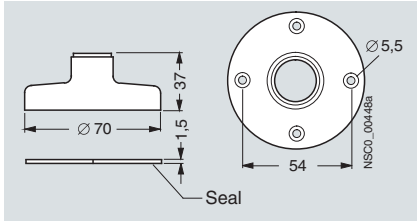

Bracket for wall mounting

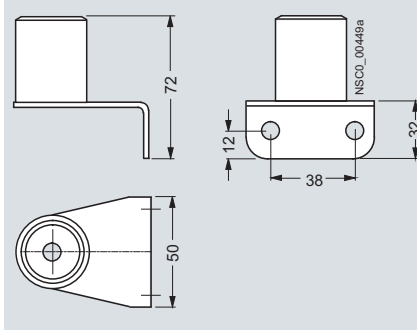

Adapter for single-hole mounting

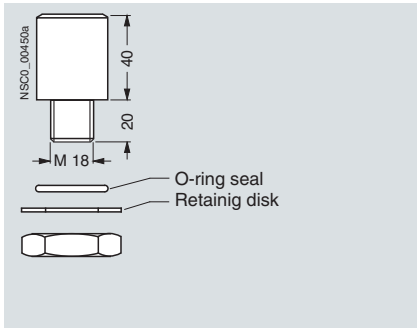

Connection element

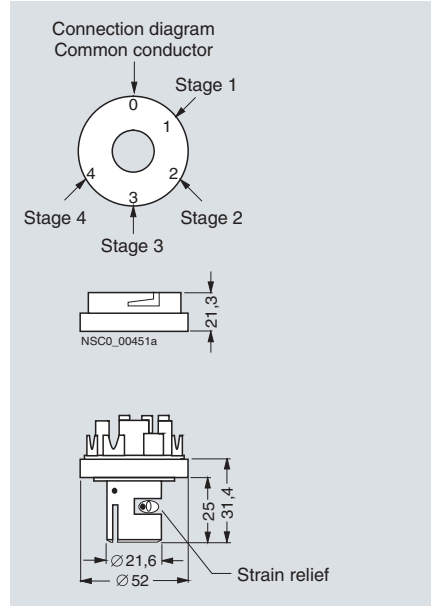

1) For horizontal mounting, only 1 element is recommended.

Dimensional drawings

Signaling column (5-tier)

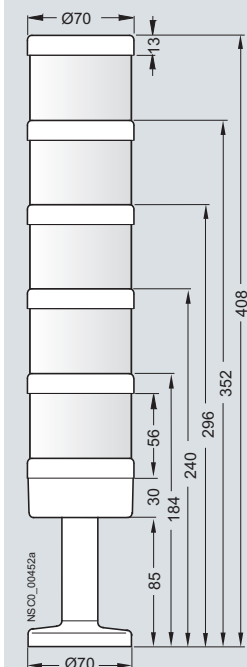

Connection elements

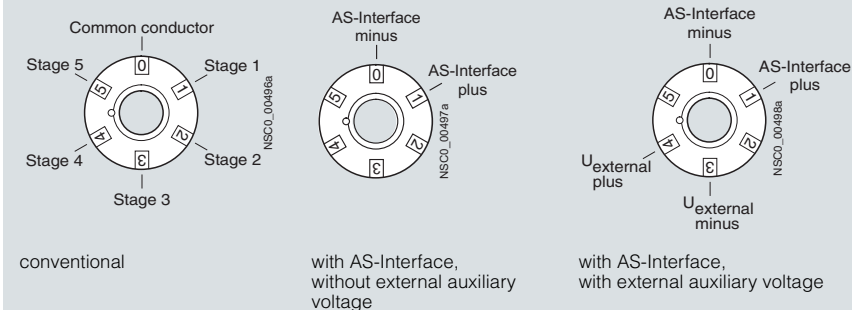

Connection element with cover for mounting on pipes

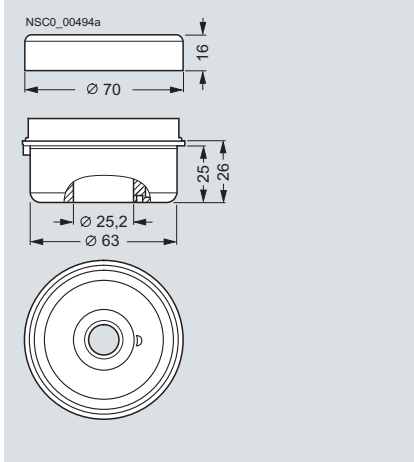

Connection element with cover for floor/angle mounting

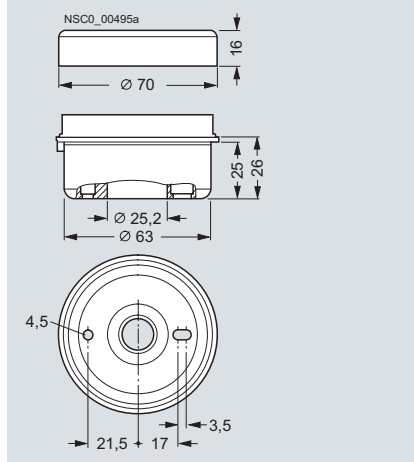

Foot with pipe

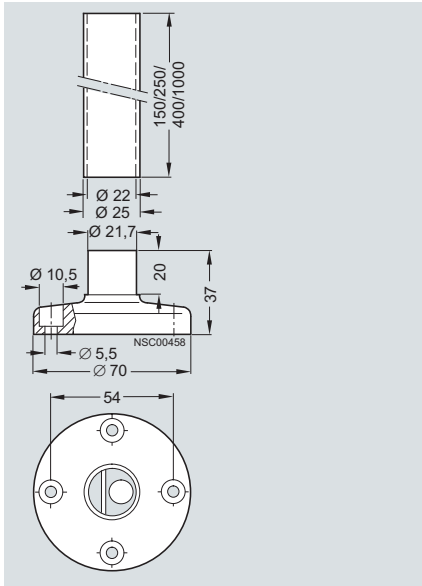

Bracket for single-sided mounting

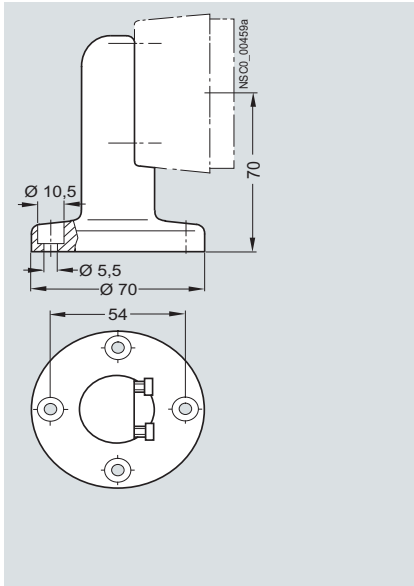

Bracket for double-sided mounting

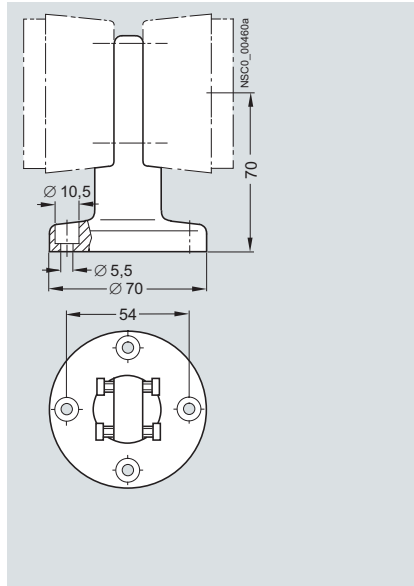

8WD5 Integrated Signal Lamps

8WD53 integrated signal lamps, 70 mm diameter

Overview



Features:

- Thermoplast enclosure, diameter 70 mm
- Degree of protection IP65
- Rated voltage 24 V, 115 V, 230 V AC/DC

Design

8WD53 integrated signal lamps can be mounted directly at any point of the machine for the purpose of giving visual signals. They are mounted by means of a Pg 29 screw base with nut.

All integrated signal lamps have a high degree of protection IP65 and are made of a material highly resistant to impact.

The special shape of the integrated signal lamps means that the light is emitted optimally in every direction (to the sides and upwards). Continuous lights (with incandescent lamp or LED) and single-flash lights are available in the following colors: red, green, yellow, clear and blue.

The LED versions of the integrated signal lamps offer a considerably longer endurance than the incandescent lamp versions. LED lights are available as a continuous light, repeated-flash light and rotating light.

Technical specifications

Type	8WD54	
General data		
Approvals	UL, CSA	
Rated voltage (AC values at 50 Hz)		
• Continuous light, BA 15d (incandescent lamp)	24 V, 115 V, 230 V AC/DC; 5 W	
• Continuous light, BA 15d (LED)	24 V, 115 V, 230 V AC/DC	
• Single-flash light	24 V AC/DC/ 125 mA; 115 V AC/ 20 mA; 230 V AC/ 15 mA	
• Lights with integrated LED	24 V AC/DC/70 mA	
Single-flash light, flash energy at 1 Hz	Ws	2
LED lights		
• Blinklight lamp, flash frequency	Hz	Approx. 1
• Rotating light, rotating frequency	min ⁻¹	Approx. 120
Inrush current		
• LED light	A	< 0.5
• Single-flash light	A	< 0.5
Enclosure		
Enclosure material	PC/ABS cover impact-resistant, black	
Spherical cap	Thermoplast (polycarbonate), impact-resistant up to 20 years	
Mounting	Ø 37 mm hole (Pg 29)	
Degree of protection	IP65	
Ambient temperature		
• Continuous light (incandescent lamp)	°C	-20 ... +60
• Single-flash light, LED	°C	-20 ... +50
Cable connection	Radial or axial	

Dimensional drawings

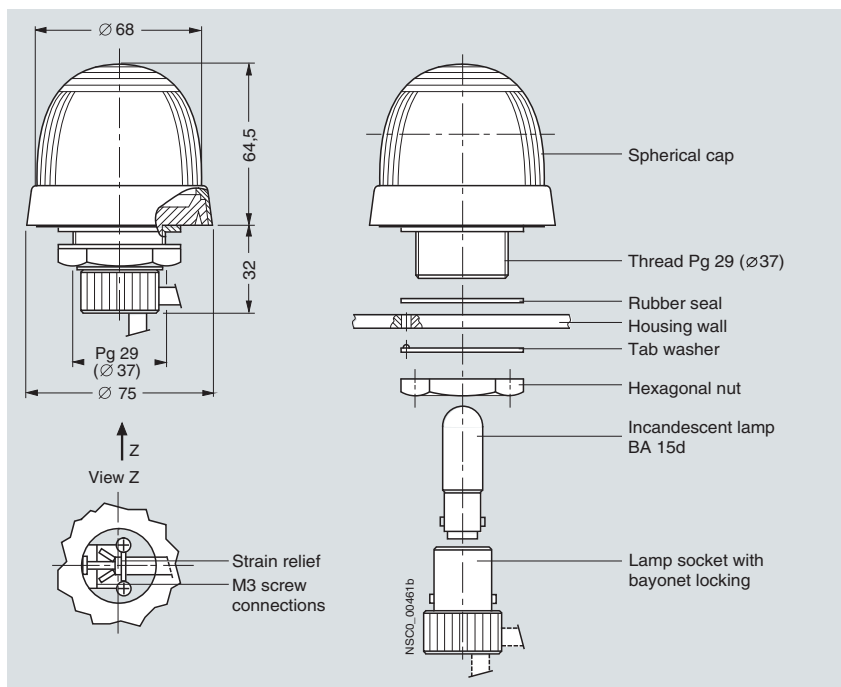

Transformers

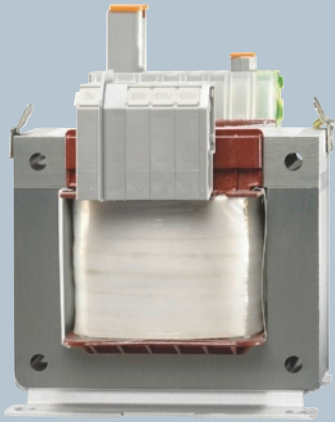
10/2 **Introduction****Single-Phase Transformers**4AM, 4AT Safety, Isolating, Control and Mains Transformers

General data

- 10/4 - Overview
- 10/4 - Design
- 10/6 - Technical specifications
- 10/12 - Schematics

4BT Power Transformers

General data

- 10/14 - Overview
- 10/14 - Design
- 10/15 - Technical specifications

4AX22, 4AX23 Safety Transformers

Resin-enclosed

- 10/17
- 4AX24 Isolating Transformers

Resin-enclosed

- 10/18
- 4AT Isolating Transformers

4AT Isolating Transformers

- 10/19 For supply of medical premises

4FL, 4FK Voltage Regulators

- 10/20 4FL voltage regulators, transformer type
- 10/21 4FK voltage regulators, magnetic type

- 10/22 Project Planning Aids

Three-Phase Transformers4AP, 4AU Safety, Isolating, Control and Mains Transformers

General data

- 10/31 - Overview
- 10/31 - Design
- 10/33 - Technical specifications
- 10/37 - Schematics

4BU Power Transformers

General data

- 10/38 - Overview
- 10/38 - Design
- 10/39 - Technical specifications
- 10/41 - Schematics

4AP, 4AU Autotransformers

For matching purposes according to EN 61558-2-13

4FL Voltage Regulators

- 10/43 4FL voltage regulators, transformer type

Project Planning Aids

- 10/44

Transformers

Introduction

Overview

Single-phase transformers



4AM



4AT



4BT



4AX24

4AT for supply
of medical
rooms

4FK



4CH

Version	Rated power kVA	Rated input voltage V AC	Rated output voltage V AC	Protection class	Page
4AM, 4AT safety, isolating, control and mains transformers					
4AM safety (mains transformers) and control transformers					
With one input voltage	0.063 ... 1.0	230 ± 5 %; 400 ± 5 %; 440 ± 5 %; 500 ± 5 %	24; 42	I	10/4
For European voltages	0.063 ... 1.0	400/230 ± 15 V	24; 42	I	10/4
In multi-voltage version	0.063 ... 1.0	550 ... 208; 600 ... 230	24; 42	I	10/4
4AM safety transformers (mains transformers)					
With one input voltage	0.025 ... 0.04	230 ± 5 %; 400 ± 5 %; 440 ± 5 %; 500 ± 5 %	24; 42	I	10/4
4AM, 4AT isolating, control and mains transformers					
4AM and 4AT with one input voltage	4AM: 0.063 ... 2.5; 4AT: 4 ... 10	230 ± 5 %; 400 ± 5 %; 440 ± 5 %; 500 ± 5 %	110; 2 × 115; 230	I	10/4
4AM and 4AT with one input voltage, without cFLus	4AM: 0.063 ... 2.5; 4AT: 4 ... 10	660 ± 5 %; 690 ± 5 %	230	I	10/4
4AM in European voltage design	0.063 ... 2.5	400/230 ± 15 V	2 × 115	I	10/4
4AM and 4AT in multi-voltage version	4AM: 0.063 ... 2.5; 4AT: 4 ... 10	550 ... 208; 600 ... 230	2 × 115	I	10/4
4AM isolating and mains transformers					
4AM with one input voltage	0.025 ... 0.04	230 ± 5 %; 400 ± 5 %; 440 ± 5 %; 500 ± 5 %	110; 230	I	10/4
4AM and 4AT with one input voltage, without cFLus	0.025 ... 0.04	660 ± 5 %; 690 ± 5 %	230	I	10/4
4AM, 4AT transformers with selectable voltages					
4AM and 4AT safety, isolating, control and mains transformers and autotransformers	4AM: 0.025 ... 2.5; 4AT: 4 ... 16	Selectable; 4AM: 12 ... 690 ¹⁾ ; 4AT: 24 ... 690 ¹⁾	Selectable; 4AM: 12 ... 690 ¹⁾ ; 4AT: 24 ... 690 ¹⁾	I I	10/4
4BT power transformers					
4BT transformers with selectable voltages	18 ... 250	Selectable; 100 ... 1000 ¹⁾	Selectable; 100 ... 1000 ¹⁾	I	10/14
4AX22, 4AX23 safety transformers					
Resin-enclosed	0.1 ... 1	230	24; 42	II	10/17
4AX24 isolating transformers					
Resin-enclosed	0.16 ... 2.5	230	230	II	10/18
4AT isolating transformers					
For supply of medical premises	2.5 ... 8	230	230-115	I	10/19
4FL, 4FK voltage regulators					
4FL transformer type	2.2 ... 63	230	230	I	10/20
4FK magnetic type	0.12 ... 0.75	230/selectable 110 ... 500	230/selectable 110 ... 500	I	10/21
	1 ... 2.5	230/selectable 110 ... 500	230/selectable 110 ... 500	I	10/21
	3.15 ... 10	400/selectable 110 ... 500	230/selectable 110 ... 500	I	10/21
4CH, 4CP variable-ratio transformers					
4CH toroidal-core variable-ratio transformers	0.28 ... 3.22	400	0 ... 230 stepless	I	2)
	0.69 ... 3.22	230	0 ... 230 stepless	I	2)
4CP pillar-type variable-ratio transformers	13.8 ... 207	400	0 ... 400 stepless	I	2)

¹⁾ **cFLus** max. 600 V.

²⁾ For more information see the interactive Catalog CA 01 and Mall.

Three-phase transformers



Version	Rated power kVA	Rated input voltage V AC	Rated output voltage V AC	Protection class	Page
4AP, 4AU safety, isolating, control and mains transformers					
4AP, 4AU isolating, control and mains transformers					
4AP and 4AU in two-voltage version	0.63 ... 16	Y 500-400 /Δ 289-230	Y 400/Δ 230	I	10/31
4AP and 4AU in multi-voltage version	0.63 ... 16	Y 520 ... 360 /Δ 300 ... 208	Y 400/Δ 230	I	10/31
4AP isolating and mains transformers					
In two-voltage version	0.16 ... 0.4	Y 500-400 /Δ 289-230	Y 400/Δ 230	I	10/31
4AP, 4AU transformers with selectable voltages					
4AP and 4AU safety, isolating, control and mains transformers and autotransformers	4AP: 0.16 ... 5; 4AU: 6.3 ... 16	Selectable; 4AP: 12 ... 690 ¹⁾ ; 4AU: 24 ... 690 ¹⁾	Selectable; 4AP: 12 ... 690 ¹⁾ ; 4AU: 24 ... 690 ¹⁾	I I	10/31
4BU power transformers					
4BU matching transformers With one input voltage	18 ... 180 ²⁾	Δ 400, 400 ± 5 %, 440, 440 ± 5 %, 480, 480 ± 5 %/ Y 400, 400 ± 5 %, 440, 440 ± 5 %, 480, 480 ± 5 %	Y 208, 400	I	10/38
4BU matching transformers With cFLus approval With one input voltage	18 ... 180 ²⁾	Δ 400, 400 ± 5 %, 440, 440 ± 5 %, 480, 480 ± 5 %/ Y 400, 400 ± 5 %, 440, 440 ± 5 %, 480, 480 ± 5 %	Y 208, 400	I	10/38
4BU transformers with selectable voltages	18 ... 400	Selectable 100 ... 1000 ¹⁾	Selectable 100 ... 1000 ¹⁾	I	10/38
4AP, 4AU autotransformers					
For matching purposes according to EN 61558-2-13	4AP: 5 ... 22.5; 4AU: 12.5 ... 50	4AP, 4AU: 480 ... 380 4AP, 4AU: 480 ... 400 (380) ³⁾	4AP, 4AU: 400 4AP, 4AU: 230 (220) ³⁾	I I	10/42
4FL voltage regulators					
4FL transformer type	6.8 ... 190	400	400	I	10/43
4CJ, 4CQ variable-ratio transformers					
4CJ toroidal-core variable-ratio transformers	2.07 ... 9.66	400	0 ... 400 stepless	I	4)
4CQ pillar-type variable-ratio transformers	16 ... 240	400	0 ... 400 stepless	I	4)

¹⁾ **cFLus** max. 600 V.

²⁾ For other ratings up to 400 kVA see the interactive Catalog CA 01 and Mall.

³⁾ Operating with 3 AC 380 V at the input terminals results in an output voltage of 3 AC 220 V.

⁴⁾ For more information see the interactive Catalog CA 01 and Mall.

Single-Phase Transformers

4AM, 4AT Safety, Isolating, Control and Mains Transformers

General data

Overview

4AM../4AT.. transformers

With the right transformer, the right voltage will be available at any conditions.

Our transformers are the right choice for each application: They work reliably, safely and worldwide under a wide range of different conditions.

The transformers are configured in user-friendly combinations as isolating, control and mains transformers according to EN 61558-2-4, -2-2, -2-1, or as safety, control and mains transformers according to EN 61558-2-6, -2-2, -2-1, or as autotransformers according to EN 61558-2-13 with selectable input and output voltages.

Note:

Mains transformers with ≤ 50 V on the output side are, in the case of SIRIUS transformers, always designed as safety transformers.

Our transformers provide optimal protection through high permissible ambient temperatures up to 40 °C or 55 °C, a high short-time rating in the case of control transformers, fuseless construction and due to its safety standard "Safety inside" EN 61558.

Design

Standards

EN 61558-2-6, -2-4, -2-2, -2-1, -2-13

The standard EN 61558 with the is the European edition of the international standard IEC 61558 (Safety of power transformers, power supply units and similar).

Some of the transformers are subject to more stringent manufacturing and testing conditions in view of these changes.

Transformers for general applications always have double or reinforced insulation with SELV voltages (can be touched, maximum 50 V AC and 120 V DC), i. e. these transformers are exclusively safety transformers.

Furthermore, all transformers are supplied with information on the protective elements with which they are protected against short-circuit and overload.

The SIRIUS transformer series contains the combined features of safety, isolating and control or mains transformers, i. e. one transformer for (virtually) all applications. SIRIUS transformers comply with the highest requirements (and with regard to safety the most stringent requirements) of the transformer designs contained in this catalog. A SIRIUS transformer is the right one whatever the application.

Rated power P_n at high ambient temperature – the characteristic for thermal load capacity

Reference conditions under which the transformers have the rated power P_n stated in the selection tables:

- Uninterrupted duty P_n
- Frequency AC 50 Hz ... 60 Hz
- Degree of protection IP00
- Installation height up to 1000 m above sea level and
- Ambient temperature t_a , type-dependent 40 °C or 55 °C

Other installation and operating conditions than this will affect the permissible permanent load capacity. In the case of the 4AM transformers, for example, with a low ambient temperature of 30 °C an increase in load of 8 % is possible (see "Load Characteristics").

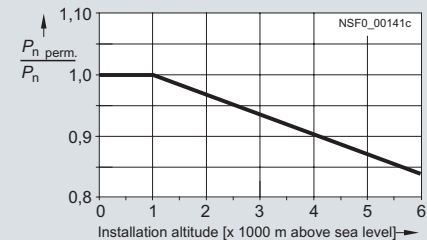
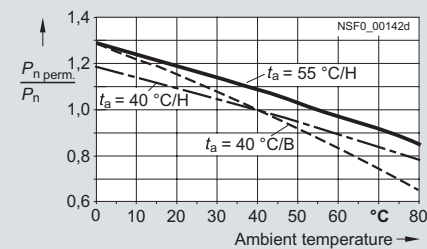

Load characteristics: Permissible transformer permanent load in relation to the ambient temperature and the installation height

Short-time rating $P_{shortt.}$ of control transformers – the characteristic variable for the dynamic capacity

The most important selection criterion for control transformers is their short-time rating $P_{shortt.}$.

This is required for switching on electromagnetic loads, e. g. contactors with high making current in relation to the holding current. According to EN 61558-2-2 "Special requirements for control transformers" the output voltage with this load should not drop more than 5 % in relation to the rated voltage in order to ensure safe switching.

Depending on their application, control transformers 4AM and 4AT ≤ 16 kVA are optimized for high short-time ratings with comparatively low ratings and thus small size.

Single-Phase Transformers

4AM, 4AT Safety, Isolating, Control and Mains Transformers

General data

Low inrush current – primary-side short-circuit and overload protection with standard circuit breakers

The single-phase transformers 4AM and 4AT for the performance range ≤ 16 kVA have been designed for protective devices which provide reliable protection against short-circuits or overloads.

Standard 3RV and 3VF circuit breakers offer optimum protection. This way, the transformers are protected on the primary side against both short-circuits and overload, without the possibility of false tripping on startup. The low inrush current, the short-circuit current and the thermal load capacity on overload are matched to the tripping characteristics of the circuit breakers.

It is also possible to protect the transformers on the secondary side against short-circuits and overloads with circuit breakers or miniature circuit breakers with C characteristics.

Note:

The specified primary-side circuit breakers are for protecting the primary side of transformers in the event of short-circuits and overload on the secondary side. In the event of a possible short-circuit on the feeder lines between the protective device and the primary side of the transformer, the rated short-circuit breaking capacity of the circuit breaker must be taken into account with regard to the maximum possible prospective short-circuit current at the place of installation. For these device assignments, see the tables in the "Technical specifications".

Design

Standard version

All 4AM and 4AT transformers are supplied for screw fixing on a mounting plate (exception: 4AM32 to 4AM40 transformers are supplied as standard for both screw mounting and with integrated standard rail mounting).

Standard rail mounting

All 4AM single-phase transformers from 25 VA to 500 VA offer a considerable saving potential in mounting requirements with snap-on mounting to the 35 mm standard mounting rail for horizontal mounting. For the 4AM single-phase transformers from 63 VA to 250 VA, snap-on mounting for the 35 mm standard mounting rail has been integrated into the fixing plate for the transformer as standard.

- **Integrated version**
The 4AM32, 4AM34, 4AM38, and 4AM40 single-phase transformers are supplied as standard for screw mounting as well as with an integrated snap-on mounting for the 35 mm standard mounting rail according to EN 60715.
- **Optional version**
4AM23, 4AM26, 4AM43, 4AM46 and 4AM48 single-phase transformers are supplied on request with a pre-mounted adapter for mounting on a 35 mm standard mounting rail.

Terminals

Screw terminals

The 4AM transformers up to a rated current of 60 A and 4AT transformers up to a rated current of 81 A in the standard version are supplied with screw terminals.

For higher currents, the transformers are supplied with flat connectors or with threaded bolts.

Cage Clamp terminals

A large number of the 4AM single-phase transformers for currents ≤ 24 A can be supplied on request with screwless Cage Clamp terminals (no multi-voltage version possible). The ground connection is designed as a Cage Clamp terminal.

Enclosure mounting

4AM and 4AT transformers are also available in protective enclosures of the degree of protection IP23 and IP54.

Required specifications for requests and orders for 4AM and 4AT transformers with selectable voltages

Rated power P_n (output division with separate SEC windings, $P_n = P_1 + P_2$, throughput rating = load rating for autotransformers), PRI and SEC voltages, frequency, vector group, degree of protection (power reduction with degrees of protection other than IP00), Order No. stem.

The Order No. stem is added to the Order No. for delivery.

Example:

Single-phase transformer with selectable voltages 0.16 kVA
PRI 415 V $\pm 5\%$, SEC 115 V,
frequency 50 Hz ... 60 Hz,
degree of protection IP00,
shield winding,
Order No. stem 4AM38 4.

4AM and 4AT autotransformers: determine the type rating P_n req.

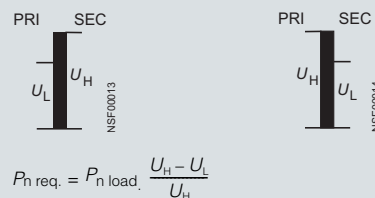

$$P_{n \text{ req.}} = P_{n \text{ load.}} \cdot \frac{U_H - U_L}{U_H}$$

(the single-phase example also applies for three-phase autotransformers)

Step-up transformer (left) and step-down transformer (right)

Single-Phase Transformers

4AM, 4AT Safety, Isolating, Control and Mains Transformers

General data

Technical specifications

Transformers	Type	4AM	4AT
<ul style="list-style-type: none"> Version Performance range (with IP00) Approvals 	kVA	EI core 0.025 ... 2.5 ULus	UI core > 2.5 ... 16
Voltage range <ul style="list-style-type: none"> Approvals for USA, Canada 	V	≤ 690	
	V	≤ 600	
Rated frequency	Hz	50 ... 60	
Thermal class <ul style="list-style-type: none"> Acc. to UL/CSA 		B Class 130	H Class 180
Ambient conditions Rated ambient temperature		Protection against harmful ambient conditions: complete impregnation in polyester resin Climate-proof for installation in rooms with an external climate to DIN 50010	
<ul style="list-style-type: none"> At rated power 	°C	40	55
<ul style="list-style-type: none"> Maximum value (after power reduction depending on load characteristics, see "Design") 	°C	80	
<ul style="list-style-type: none"> Minimum value 	°C	-25	
Relative air humidity <ul style="list-style-type: none"> Mean value up to Maximum value for 30 days/year At 40 °C occasionally 	%	80	
	%	95	
	%	100	
Protection class		I	
Degree of protection <ul style="list-style-type: none"> Without enclosure With protective enclosure (acc. to "Selection and ordering data", see Catalog LV 1) Version 		IP00	IP23 or IP54
		IP23, IP54: sheet-steel enclosure coated with epoxy resin, color gray RAL 7032	
Installation height		Up to 1000 m above sea level (above this, power reduction is necessary)	
Protective devices <ul style="list-style-type: none"> External 		The transformers can be protected against short-circuits and overload on the primary and secondary side with circuit breakers. For reliable protection against short-circuits, overload and touch, the cables between the output terminals of the transformer and the load must have a negligible line impedance. For more details see DIN VDE 0100 (Erection of low-voltage systems) Part 410, Part 520 (particularly section 525) and Part 600 (similar to IEC 60364-4-41, -5-52 and -6). Assigned protective devices (see "Primary-side short-circuit and overload protection with motor starter protectors")	
Connection methods <ul style="list-style-type: none"> Terminal arrangement (see "Schematics") For terminal versions and connectable cross-sections (see "Project planning aids") 		The permissible conductor cross-sections are assigned to the specified terminal types. Refer to DIN VDE 0298-4 and EN 60204 for the permissible conductor cross-sections for the specified current according to the installation type. The terminals used are finger-safe according to EN 50274. Other terminal sizes than standard versions on request.	
Mounting position		The permissible mounting position for each version is shown in the "Project planning aids".	

Further technical specifications can be found on the Internet at <http://www.siemens.com/sirius-supplying>.

Single-Phase Transformers

4AM, 4AT Safety, Isolating, Control and Mains Transformers

General data

Rated power outputs at different ambient temperatures

- With electrically isolated windings
- Degree of protection IP00
- According to EN 61558, **CLASS**

Transformers Type	Rated power P_n kVA	Permissible transformer load depending on the ambient temperature							
		$t_a = 60\text{ °C}$ kVA	$t_a = 55\text{ °C}$ kVA	$t_a = 50\text{ °C}$ kVA	$t_a = 45\text{ °C}$ kVA	$t_a = 40\text{ °C}$ kVA	$t_a = 35\text{ °C}$ kVA	$t_a = 30\text{ °C}$ kVA	$t_a = 25\text{ °C}$ kVA
4AM transformers									
4AM23 4	0.025	0.021	0.022	0.023	0.024	0.025	0.026	0.027	0.0278
4AM26 4	0.04	0.0336	0.0352	0.0368	0.0384	0.04	0.0416	0.0432	0.0444
4AM32 4	0.063	0.0529	0.0554	0.058	0.0605	0.063	0.0655 ¹⁾	0.068 ¹⁾	0.0699 ¹⁾
4AM34 4	0.1	0.084	0.088	0.092	0.096	0.1	0.104 ¹⁾	0.108 ¹⁾	0.111 ¹⁾
4AM38 4	0.16	0.134	0.141	0.147	0.154	0.16	0.166 ¹⁾	0.173 ¹⁾	0.178 ¹⁾
4AM40 4	0.25	0.21	0.22	0.23	0.24	0.25	0.26	0.27	0.278
4AM43 4	0.315	0.265	0.277	0.29	0.302	0.315	0.328	0.34	0.35
4AM46 4	0.4	0.336	0.352	0.368	0.384	0.4	0.416	0.432	0.444
4AM48 4	0.5	0.42	0.44	0.46	0.48	0.5	0.52	0.54	0.555
4AM52 4	0.63	0.529	0.554	0.58	0.605	0.63	0.655	0.68	0.699
4AM55 4	0.8	0.672	0.704	0.736	0.768	0.8	0.832	0.864	0.888
4AM57 4	1	0.84	0.88	0.92	0.96	1	1.04	1.08	1.11
4AM61 4	1.6	1.34	1.41	1.47	1.54	1.6	1.66	1.73	1.78
4AM64 4	2	1.68	1.76	1.84	1.92	2	2.08	2.16	2.22
4AM65 4	2.5	2.1	2.2	2.3	2.4	2.5	2.6	2.7	2.78
4AT transformers									
4AT30 3	4	3.88	4	4.12	4.24	4.4	4.52	4.64	4.76
4AT36 1	5	4.85	5	5.15	5.3	5.5	5.65	5.8	5.95
4AT36 3	6.3	6.11	6.3	6.49	6.68	6.93	7.12	7.31	7.5
4AT39 1	8	7.76	8	8.24	8.48	8.8	9.04	9.28	9.52
4AT39 3	10	9.7	10	10.3	10.6	11	11.3	11.6	11.9
4AT43 0	11.2	10.9	11.2	11.5	11.9	12.3	12.7	13	13.3
4AT43 1	12.5	12.1	12.5	12.9	13.3	13.8	14.1	14.5	14.9
4AT43 2	14	13.6	14	14.4	14.8	15.4	15.8	16.2	16.7
4AT45 0	16	15.5	16	16.5	17	17.6	18.1	18.6	19

¹⁾ For control transformers, the values $t_a = 40\text{ °C}$ apply.

Operation characteristics

- According to EN 61558-2-6, EN 61558-2-4, EN 61558-2-2, EN 61558-2-1

Transformers Type	Rated power P_n 50 Hz ... 60 Hz 1000 m above sea level Degree of protection IP00 kVA	Core size	Voltage rise in no-load operation (operating temperature) u_A approx. %	Voltage drop on rated load ¹⁾ u_R approx. %	Short-circuit voltage ¹⁾ u_z approx. %	Degree of efficiency η approx. %
			%	%	%	%
4AM transformers: $t_a = 40\text{ °C/B}$						
4AM23 4	0.025	EI 60/20	26	17.6	17.6	74
4AM26 4	0.04	EI 66/22	23	15.3	15.3	76
4AM32 4	0.063	EI 84/28	10	8.4	8.4	85
4AM34 4	0.1	EI 84/42	10	7.7	7.7	86
4AM38 4	0.16	EI 96/44	10.4	7.6	7.7	86
4AM40 4	0.25	EI 96/58	7.2	5.4	5.4	89
4AM43 4	0.315	EI 105/60	6.6	4.9	5	90
4AM46 4	0.4	EI 120/52	5.7	4.3	4.4	91
4AM48 4	0.5	EI 120/72	5	3.8	3.8	91
4AM52 4	0.63	EI 150/48	4.7	3.6	3.7	92
4AM55 4	0.8	EI 150/65	4	3	3.1	92
4AM57 4	1	EI 150/90	3.2	2.5	2.5	93
4AM61 4	1.6	EI 174/82	2.4	1.9	2.1	96
4AM64 4	2	EI 174/102	2.1	1.7	1.9	96
4AM65 4	2.5	EI 192/110	1.6	1.3	1.6	96
4AT transformers: $t_a = 55\text{ °C/H}$						
4AT30 3	4	UI 150/75	3.8	2.7	2.9	95
4AT36 1	5	UI 180/75	5.5	3.8	3.9	94
4AT36 3	6.3	UI 180/75	4.3	3.1	3.3	95
4AT39 1	8	UI 210/70	4.3	3.1	3.3	95
4AT39 3	10	UI 210/70	3.5	2.5	3.3	96
4AT43 0	11.2	UI 240/80	3.9	2.8	2.8	95
4AT43 1	12.5	UI 240/80	3.5	2.5	2.6	96
4AT43 2	14	UI 240/80	3.1	2.2	2.4	96
4AT45 0	16	UI 240/107	2.9	2.1	2.1	96

Calculation of power loss P_V

$$P_V = \frac{P_n (100 - \eta)}{\eta} \text{ [kW]}$$

¹⁾ Winding reference temperature: 20 °C.

Single-Phase Transformers

4AM, 4AT Safety, Isolating, Control and Mains Transformers

General data

Primary-side short-circuit and overload protection with motor starter protectors

Version with one input voltage

Trans- formers	Rated power P_n kVA	Motor starter protector version: Motor protection ¹⁾ Type	Rated input voltage U_{1N} in V																	
			690	660	600	575	550	525	500	480	460	440	415	400	380	240	230	220	208	200
4AM transformers																				
4AM23 4	0.025	3RV10 11-□□□10 Set value in A	OAA	OAA	OAA	OAA	OAA	OAA	OAA	OAA	OAA	OAA	OAA	OAA	OAA	OAA	OAA	OAA	OAA	OAA
4AM26 4	0.04	3RV10 11-□□□10 Set value in A	OAA	OAA	OAA	OAA	OAA	OAA	OAA	OAA	OAA	OAA	OAA	OAA	OAA	OAA	OAA	OAA	OAA	OAA
4AM32 4	0.063	3RV10 11-□□□10 Set value in A	OBA	OBA	OBA	OBA	OCA	OCA	OCA	OCA	OCA	OCA	OCA	OCA	OCA	OCA	OCA	OCA	OCA	OCA
4AM34 4	0.1	3RV10 11-□□□10 Set value in A	ODA	ODA	OEA	OEA	OEA	OEA	OEA	OEA	OEA	OEA	OEA	OEA	OEA	OEA	OEA	OEA	OEA	OEA
4AM38 4	0.16	3RV10 11-□□□10 Set value in A	OFA	OFA	OFA	OFA	OFA	OFA	OFA	OFA	OFA	OFA	OFA	OFA	OFA	OFA	OFA	OFA	OFA	OFA
4AM40 4	0.25	3RV10 11-□□□10 Set value in A	OHA	OHA	OHA	OHA	OJA	OJA	OJA	OJA	OJA	OJA	OJA	OJA	OJA	OJA	OJA	OJA	OJA	OJA
4AM43 4	0.315	3RV10 11-□□□10 Set value in A	OJA	OJA	OJA	OJA	OKA	OKA	OKA	OKA	1AA	1AA	1AA	1AA	1AA	1AA	1AA	1AA	1AA	1AA
4AM46 4	0.4	3RV10 11-□□□10 Set value in A	OKA	OKA	OKA	OKA	1AA	1AA	1AA	1AA	1AA	1AA	1AA	1AA	1AA	1AA	1AA	1AA	1AA	1AA
4AM48 4	0.5	3RV10 11-□□□10 Set value in A	1AA	1AA	1AA	1BA	1BA	1BA	1BA	1BA	1BA	1BA	1BA	1BA	1BA	1BA	1BA	1BA	1BA	1BA
4AM52 4	0.63	3RV10 11-□□□10 Set value in A	1AA	1BA	1BA	1BA	1BA	1BA	1CA	1CA	1CA	1CA	1CA	1CA	1CA	1CA	1CA	1CA	1CA	1CA
4AM55 4	0.8	3RV10 11-□□□10 Set value in A	1CA	1CA	1CA	1DA	1DA	1DA	1DA	1DA	1DA	1DA	1DA	1DA	1DA	1DA	1DA	1DA	1DA	1DA
4AM57 4	1	3RV10 11-□□□10 Set value in A	1DA	1DA	1DA	1DA	1DA	1EA	1EA	1EA	1EA	1EA	1EA	1EA	1EA	1EA	1EA	1EA	1EA	1EA
4AM61 4	1.6	3RV10 11-□□□10 3RV10 21-□□□10 Set value in A	1FA	1FA	1FA	1FA	1FA	1GA	1GA	1GA	1GA	1GA	1GA	1GA	1GA	1GA	1GA	1GA	1GA	1GA
4AM64 4	2	3RV10 11-□□□10 3RV10 21-□□□10 Set value in A	1GA	1GA	1GA	1GA	1HA	1HA	1HA	1HA	1HA	1HA	1HA	1HA	1HA	1HA	1HA	1HA	1HA	1HA
4AM65 4	2.5	3RV10 11-□□□10 3RV10 21-□□□10 Set value in A	1GA	1GA	1HA	1HA	1HA	1JA	1JA	1JA	1JA	1JA	1JA	1JA	1JA	1JA	1JA	1JA	1JA	1JA
4AT transformers																				
4AT30 3	4	3RV10 11-□□□10 3RV10 21-□□□10 3RV10 31-□□□10 Set value in A	1JA	1JA	--	--	--	--	--	--	--	--	--	--	--	--	--	--	--	--
4AT36 1	5	3RV10 11-□□□10 3RV10 21-□□□10 3RV10 31-□□□10 Set value in A	1KA	1KA	1KA	--	--	--	--	--	--	--	--	--	--	--	--	--	--	--
4AT36 3	6.3	3RV10 21-□□□10 3RV10 31-□□□10 Set value in A	4AA	4AA	4BA	4BA	4BA	4BA	4CA	4CA	4CA	4CA	4CA	4DA	4DA	4DA	4DA	4DA	4DA	4DA
4AT39 1	8	3RV10 21-□□□10 3RV10 31-□□□10 3RV10 41-□□□10 Set value in A	4BA	4BA	4CA	4CA	4CA	4DA	4DA	4DA	4DA	4DA	4DA	4DA	4DA	4DA	4DA	4DA	4DA	4DA
4AT39 3	10	3RV10 21-□□□10 3RV10 31-□□□10 3RV10 41-□□□10 Set value in A	4CA	4CA	4DA	4DA	4DA	--	--	--	--	--	--	--	--	--	--	--	--	--
4AT43 0	11.2	3RV10 31-□□□10 3RV10 41-□□□10 Set value in A	4EA	4EA	4EA	4EA	4EA	4FA	4FA	4FA	4FA	4FA	4FA	4GA	4GA	4GA	4HA	--	--	--
4AT43 1	12.5	3RV10 31-□□□10 3RV10 41-□□□10 Set value in A	4EA	4EA	4FA	4FA	4FA	4FA	4FA	4FA	4GA	4GA	4GA	4HA	4HA	--	--	--	--	--
4AT43 2	14	3RV10 31-□□□10 3RV10 41-□□□10 Set value in A	4EA	4FA	4FA	4FA	4FA	4GA	4GA	4HA	4HA	4HA	--	--	--	--	--	--	--	--
4AT45 0	16	3RV10 31-□□□10 3RV10 41-□□□10 Set value in A	4FA	4FA	4GA	4GA	4HA	--	--	--	--	--	--	--	--	--	--	--	--	--

¹⁾ Two-pole or single-pole motor starter protectors can be connected (3 conducting paths in series).

Single-Phase Transformers

4AM, 4AT Safety, Isolating, Control and Mains Transformers

General data

European voltage and multi-voltage version

Trans- formers	Rated power P_n kVA	Motor starter protectors ¹⁾ Type	Rated input voltage U_{1N} in V																		
			690	660	600	575	550	525	500	480	460	440	415	400	380	240	230	220	208	200	190
Motor starter protector version for 4AM transformers: transformer protection																					
4AM23 4	0.025	3RV14 21-□□□10 Set value in A	0AA	0AA	0AA	0AA	0AA	0AA	0AA	0AA	0AA	0AA	0AA	0AA	0AA	0CA	0CA	0CA	0CA	0CA	0CA
4AM26 4	0.04	3RV14 21-□□□10 Set value in A	0AA	0AA	0AA	0AA	0AA	0BA	0BA	0BA	0BA	0BA	0CA	0CA	0DA	0DA	0DA	0EA	0EA	0EA	0EA
4AM32 4	0.063	3RV14 21-□□□10 Set value in A	0BA	0BA	0BA	0CA	0CA	0CA	0CA	0CA	0DA	0DA	0DA	0DA	0DA	0FA	0FA	0FA	0GA	0GA	0GA
4AM34 4	0.1	3RV14 21-□□□10 Set value in A	0DA	0DA	0EA	0EA	0EA	0EA	0EA	0FA	0FA	0FA	0FA	0FA	0FA	0FA	0HA	0HA	0HA	0JA	0JA
4AM38 4	0.16	3RV14 21-□□□10 Set value in A	0FA	0FA	0GA	0GA	0GA	0GA	0GA	0HA	0HA	0HA	0HA	0HA	0HA	0KA	0KA	0KA	1AA	1AA	1AA
4AM40 4	0.25	3RV14 21-□□□10 Set value in A	0HA	0HA	0HA	0HA	0JA	0JA	0JA	0JA	0JA	0KA	0KA	0KA	0KA	1BA	1BA	1BA	1BA	1BA	1BA
4AM43 4	0.315	3RV14 21-□□□10 Set value in A	0JA	0JA	0JA	0JA	0KA	0KA	0KA	0KA	0KA	0KA	0KA	0KA	1AA	1AA	1CA	1CA	1CA	1CA	1CA
4AM46 4	0.4	3RV14 21-□□□10 Set value in A	0KA	0KA	0KA	0KA	1AA	1AA	1AA	1AA	1AA	1AA	1AA	1AA	1BA	1BA	1DA	1DA	1DA	1DA	1DA
4AM48 4	0.5	3RV14 21-□□□10 Set value in A	1AA	1AA	1AA	1AA	1BA	1BA	1BA	1BA	1BA	1BA	1BA	1BA	1CA	1CA	1EA	1EA	1EA	1EA	1EA
4AM52 4	0.63	3RV14 21-□□□10 Set value in A	1AA	1BA	1BA	1BA	1BA	1CA	1CA	1CA	1CA	1CA	1CA	1CA	1DA	1DA	1FA	1FA	1FA	1FA	1FA
4AM55 4	0.8	3RV14 21-□□□10 Set value in A	1BA	1CA	1CA	1CA	1CA	1DA	1DA	1DA	1DA	1DA	1DA	1DA	1EA	1EA	1GA	1GA	1GA	1GA	1GA
4AM57 4	1	3RV14 21-□□□10 Set value in A	1DA	1DA	1DA	1DA	1DA	1EA	1EA	1EA	1EA	1EA	1EA	1EA	1FA	1FA	1HA	1HA	1HA	1HA	1HA
4AM61 4	1.6	3RV14 21-□□□10 Set value in A	1FA	1FA	1FA	1FA	1GA	1GA	1GA	1GA	1GA	1GA	1GA	1GA	1GA	1GA	1KA	1KA	1KA	1KA	1KA
4AM64 4	2	3RV14 21-□□□10 Set value in A	1FA	1GA	1GA	1GA	1HA	1HA	1HA	1HA	1HA	1HA	1HA	1HA	1HA	1HA	4AA	4AA	4AA	4AA	4AA
4AM65 4	2.5	3RV14 21-□□□10 3RV14 31-□□□10 Set value in A	1HA	1HA	1HA	1HA	1JA	1JA	1JA	1JA	1JA	1JA	1JA	1JA	1KA	1KA	4BA	4BA	4BA	4BA	4BA
Motor starter protector version for 4AT transformers: motor protection																					
4AT30 3	4	3RV10 11-□□□10 3RV10 21-□□□10 3RV10 31-□□□10 Set value in A	1JA	1JA	--	--	--	--	--	--	--	--	--	--	--	--	--	--	--	--	--
4AT36 1	5	3RV10 11-□□□10 3RV10 21-□□□10 3RV10 31-□□□10 Set value in A	1KA	1KA	1KA	--	--	--	--	--	--	--	--	--	--	--	--	--	--	--	--
4AT36 3	6.3	3RV10 21-□□□10 3RV10 31-□□□10 Set value in A	4AA	4AA	4BA	4BA	4BA	4BA	4CA	4CA	4CA	4CA	4DA	4DA	4DA	--	--	--	--	--	--
4AT39 1	8	3RV10 21-□□□10 3RV10 31-□□□10 3RV10 41-□□□10 Set value in A	4BA	4BA	4CA	4CA	4CA	4DA	4DA	4DA	4DA	--	--	--	--	--	--	--	--	--	--
4AT39 3	10	3RV10 21-□□□10 3RV10 31-□□□10 3RV10 41-□□□10 Set value in A	4CA	4CA	4DA	4DA	4DA	--	--	--	--	--	--	--	--	--	--	--	--	--	--
4AT43 0	11.2	3RV10 31-□□□10 3RV10 41-□□□10 Set value in A	4EA	4EA	4EA	4EA	4FA	4FA	4FA	4FA	4GA	4GA	4GA	4HA	--	--	--	--	--	--	--
4AT43 1	12.5	3RV10 31-□□□10 3RV10 41-□□□10 Set value in A	4EA	4EA	4FA	4FA	4FA	4FA	4FA	4GA	4GA	4GA	4HA	4HA	--	--	--	--	--	--	--
4AT43 2	14	3RV10 31-□□□10 3RV10 41-□□□10 Set value in A	4EA	4FA	4FA	4FA	4FA	4GA	4GA	4HA	4HA	4HA	--	--	--	--	--	--	--	--	--
4AT45 0	16	3RV10 31-□□□10 3RV10 41-□□□10 Set value in A	4FA	4FA	4GA	4GA	4HA	4HA	--	--	--	--	--	--	--	--	--	--	--	--	--

¹⁾ Two-pole or single-pole motor starter protectors can be connected (3 conducting paths in series).

Single-Phase Transformers

4AM, 4AT Safety, Isolating, Control and Mains Transformers

General data

Secondary-side short-circuit and overload protection with motor starter protector or miniature circuit breaker¹⁾

Transformers	Rated power P_n kVA	Motor starter protectors Version: Motor protection ²⁾ Type	Rated output voltage U_{2N} in V				
			230	115	110	42	24
4AM transformers							
4AM23 4	0.025	3RV10 11-□□□10 Set value in A	0AA 0.14	0DA 0.26	0DA 0.29	0HA 0.75	1AA 1.3
4AM26 4	0.04	3RV10 11-□□□10 Set value in A	0CA 0.21	0FA 0.41	0FA 0.45	0KA 1.2	1CA 2.1
4AM32 4	0.063	3RV10 11-□□□10 Set value in A	0EA 0.34	0HA 0.68	0HA 0.72	1BA 1.9	1EA 3.3
4AM34 4	0.1	3RV10 11-□□□10 Set value in A	0GA 0.55	0KA 1.1	0KA 1.14	1DA 3	1GA 5.2
4AM38 4	0.16	3RV10 11-□□□10 Set value in A	0JA 0.86	1BA 1.72	1BA 1.82	1FA 4.8	1JA 8.4
4AM40 4	0.25	3RV10 11-□□□10 3RV10 21-□□□10 Set value in A	1AA -- 1.37	1DA -- 2.7	1DA -- 2.8	1HA -- 7.4	-- 4AA 13
4AM43 4	0.315	3RV10 11-□□□10 3RV10 21-□□□10 Set value in A	1BA -- 1.72	1EA -- 3.4	1EA -- 3.6	1JA -- 9.4	-- 4BA 16.5
4AM46 4	0.4	3RV10 11-□□□10 3RV10 21-□□□10 Set value in A	1CA -- 2.2	1FA -- 4.4	1FA -- 4.6	1KA -- 12	-- 4CA 21
4AM48 4	0.5	3RV10 11-□□□10 3RV10 21-□□□10 3RV10 31-□□□10 Set value in A	1DA -- -- 2.7	1GA -- -- 5.4	1GA -- -- 5.7	-- 4AA -- 15	-- -- 4EA 26
4AM52 4	0.63	3RV10 11-□□□10 3RV10 21-□□□10 3RV10 31-□□□10 Set value in A	1EA -- -- 3.4	1HA -- -- 6.8	1HA -- -- 7.2	-- 4BA -- 18.8	-- -- 4FA 33
4AM55 4	0.8	3RV10 11-□□□10 3RV10 21-□□□10 3RV10 31-□□□10 Set value in A	1FA -- -- 4.4	1JA -- -- 8.8	1JA -- -- 9.2	-- 4DA -- 24	-- -- 4GA 42
4AM57 4	1	3RV10 11-□□□10 3RV10 31-□□□10 3RV10 41-□□□10 Set value in A	1GA -- -- 5.4	1KA -- -- 10.8	1KA -- -- 11.4	-- 4EA -- 30	-- -- 4JA 52
4AM61 4	1.6	3RV10 11-□□□10 3RV10 31-□□□10 3RV10 41-□□□10 Set value in A	1JA -- -- 8.6	-- 4BA -- 17	-- 4BA -- 18.5	-- 4HA -- 48	-- -- 4LA 81
4AM64 4	2	3RV10 11-□□□10 3RV10 31-□□□10 3RV10 41-□□□10 Set value in A	1KA -- -- 10.9	-- 4DA -- 22	-- 4DA -- 23	-- -- 4JA 60	-- -- 4MA 101
4AM65 4	2.5	3RV10 21-□□□10 3RV10 31-□□□10 3RV10 41-□□□10 3VF32 11-□□□□□-0AA0 Set value in A	4AA -- -- -- 13.6	-- 4EA -- -- 27	-- 4EA -- -- 28	-- -- 4KA -- 72	-- -- -- 1BU41 125
4AT transformers							
4AT30 3	4	3RV10 21-□□□10 3RV10 31-□□□10 Set value in A	4CA -- 21	-- 4GA 41	-- -- --	-- -- --	-- -- --
4AT36 1	5	3RV10 31-□□□10 3RV10 41-□□□10 Set value in A	4EA -- 26	-- 4JA 51	-- -- --	-- -- --	-- -- --
4AT36 3	6.3	3RV10 31-□□□10 3RV10 41-□□□10 Set value in A	4FA -- 32	-- 4KA 64	-- -- --	-- -- --	-- -- --
4AT39 1	8	3RV10 31-□□□10 3RV10 41-□□□10 Set value in A	4GA -- 41	-- 4LA 81	-- -- --	-- -- --	-- -- --
4AT39 3	10	3RV10 41-□□□10 Set value in A	4JA 51	4MA 100	-- --	-- --	-- --

¹⁾ Miniature circuit breaker on request.

²⁾ Two-pole or single-pole motor starter protectors can be connected (3 conducting paths in series).

Single-Phase Transformers

4AM, 4AT Safety, Isolating, Control and Mains Transformers

General data

Short-time rating of control transformers $P_{\text{short.}}^{1)} = f(p.f.)$ for $U_2 = 0.95 \times U_{2N}$

Trans- formers	Rated power P_n	Short-time rating $P_{\text{short.}}^{1)}$ with p.f. of										Voltage rise in no-load operation (operating temperature)	Voltage drop on rated load (at 20 °C)	Short- circuit voltage (at 20 °C)	
		0.1	0.2	0.3	0.4	0.5	0.6	0.7	0.8	0.9	1				u_A %
Type	kVA	kVA	kVA	kVA	kVA	kVA	kVA	kVA	kVA	kVA	kVA	kVA			
4AM transformers															
4AM32 4	0.063	0.56	0.37	0.28	0.23	0.19	0.16	0.14	0.12	0.12	0.11	10	8.4	8.5	
4AM34 4	0.1	0.96	0.62	0.46	0.37	0.31	0.26	0.23	0.21	0.19	0.17	10	7.7	7.7	
4AM38 4	0.16	1.52	0.98	0.73	0.58	0.49	0.42	0.37	0.33	0.3	0.28	10.4	7.6	7.7	
4AM40 4	0.25	2.5	1.62	1.24	1	0.85	0.74	0.66	0.59	0.54	0.51	7.2	5.4	5.4	
4AM43 4	0.315	3.4	2.15	1.63	1.33	1.12	0.97	0.86	0.77	0.71	0.67	6.6	4.9	5	
4AM46 4	0.4	3.51	2.53	2	1.67	1.44	1.26	1.13	1	0.95	0.92	5.7	4.3	4.4	
4AM48 4	0.5	5.34	3.75	2.9	2.4	2	1.75	1.55	1.4	1.3	1.25	5	3.8	3.8	
4AM52 4	0.63	5.05	3.85	3.15	2.7	2.35	2.1	1.9	1.75	1.65	1.6	4.7	3.6	3.7	
4AM55 4	0.8	7.69	5.8	4.65	3.9	3.4	3	2.7	2.5	2.3	2.25	4	3	3.1	
4AM57 4	1.0	12.1	8.85	7	5.85	5	4.4	3.95	3.6	3.3	3.2	3.2	2.5	2.5	
4AM61 4	1.6	12.1	10.3	9	8.1	7.3	6.8	6.4	6.1	5.9	6.4	2.4	1.9	2.1	
4AM64 4	2	15.8	13.5	11.9	10.7	9.7	9	8.5	8.1	7.9	8.6	2.1	1.7	1.9	
4AM65 4	2.5	19.6	17.3	15.6	14.3	13.3	12.5	12	11.6	11.5	13.2	1.6	1.3	1.6	
4AT transformers															
<i>With one input voltage</i>															
4AT30 3	4	31.2	25	20.9	18	16	14.4	13.2	12.2	11.6	11.7	3.8	2.7	2.9	
4AT36 1	5	44.3	32.5	25.8	21.4	18.5	16.1	14.4	13.1	12.1	11.6	5.5	3.8	3.9	
4AT36 3	6.3	40.7	33.4	28.4	24.9	22.5	20.3	18.7	17.5	16.7	16.9	4.3	3.1	3.3	
4AT39 1	8	52.7	43.1	36.5	31.8	28.5	25.6	23.4	21.9	20.8	21.3	4.3	3.1	3.3	
4AT39 3	10	42	37.7	34.4	31.9	30	28.4	27.3	26.7	26.8	29	3.5	2.5	3.3	
<i>In European voltage version or multi-voltage version</i>															
4AT30 3	4	45.8	32.6	25.4	20.9	17.8	15.5	13.8	12.5	11.5	11	4.1	2.9	2.9	
4AT36 1	5	48	36.7	27.9	22.6	19	16.5	14.6	13.1	12	11.2	5.9	4	4.1	
4AT36 3	6.3	54.9	42.1	33.8	28.4	24.5	21.7	19.5	17.8	16.5	16.1	4.7	3.2	3.3	
4AT39 1	8	70	53.6	43	36	31.1	27.5	24.8	22.6	21	20.4	4.6	3.2	3.3	
4AT39 3	10	64.1	53.3	45.8	40.5	36.4	33.3	30.9	29.1	27.9	29.4	3.7	2.6	2.9	
<i>With selectable voltages</i>															
4AT30 3	4	45.8	32.6	25.4	20.9	17.8	15.5	13.8	12.5	11.5	11	4.1	2.9	2.9	
4AT36 1	5	48	36.7	27.9	22.6	19	16.5	14.6	13.1	12	11.2	5.9	4	4.1	
4AT36 3	6.3	54.9	42.1	33.8	28.4	24.5	21.7	19.5	17.8	16.5	16.1	4.7	3.2	3.3	
4AT39 1	8	70	53.6	43	36	31.1	27.5	24.8	22.6	21	20.4	4.6	3.2	3.3	
4AT39 3	10	64.1	53.3	45.8	40.5	36.4	33.3	30.9	29.1	27.9	29.4	3.7	2.6	2.9	
4AT43 0	11.2	117	85.8	67.8	56.3	48.3	42.4	37.9	34.5	31.9	30.7	4.1	2.9	2.9	
4AT43 1	12.5	117	89.5	72.9	61.8	53.8	47.9	43.3	39.8	37.2	36.7	3.7	2.6	2.7	
4AT43 2	14	111	90	75.9	66	58.7	53.1	48.8	45.5	43.2	44.2	3.3	2.3	2.5	
4AT45 0	16	187	140	112	94	81.2	71.7	64.5	59	54.7	53.4	3.1	2.1	2.2	

¹⁾ $P_{\text{short.}}$ applies to up to 300 contactor operations per hour. The specified rating is the typical maximum short-time rating.

Single-Phase Transformers

4AM, 4AT Safety, Isolating, Control and Mains Transformers

General data

Schematics

With one input voltage

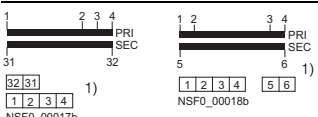
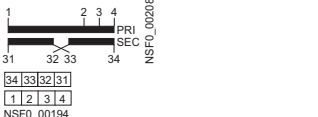
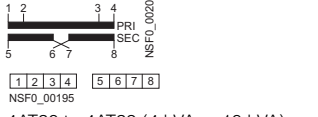
Circuit diagrams and terminal assignments ¹⁾	Rated input voltage U_{1N}	Rated output voltage U_{2N}	Transformer type	Primary			Secondary	
				Terminals			Terminals	Links
	V	V		U_{1N}	$U_{1N} + 5\%$	$U_{1N} - 5\%$	U_{2N}	
 <p>4AM (≤ 2.5 kVA) 4AT (4 kVA ... 16 kVA)</p>	$U_{1N} \pm 5\%$	U_{2N}	4AM23 to 4AM65 4AT30 to 4AT45	1-3	1-4	1-2	31-32 5-6	--
 <p>4AM32 to 4AM65 (≤ 2.5 kVA)</p>	$U_{1N} \pm 5\%$	2 x 115	4AM32 to 4AM65	1-3	1-4	1-2	230 V: 31-34 ²⁾ 115 V: 31-34 ²⁾	32-33 31-32; 33-34
 <p>4AT30 to 4AT39 (4 kVA ... 10 kVA)</p>			4AT30 to 4AT39	1-3	1-4	2-3	230 V: 5-8 115 V: 5-8	6-7 5-6; 7-8

¹⁾ For Cage Clamp terminals, the ground connection is routed to the terminal. The order of terminal assignments then changes as follows .
²⁾ Terminals 31–34 are duplicated in the Cage Clamp version.

For European voltages

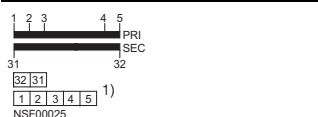
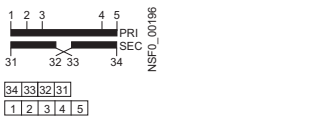
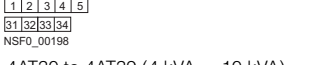
Circuit diagrams and terminal assignments ¹⁾	Rated input voltage U_{1N}	Rated output voltage U_{2N}	Transformer type	Primary			Secondary	
				Terminals			Terminals	Links
	V	V		U_{1N}	$U_{1N} + 15\text{ V}$	$U_{1N} - 15\text{ V}$	U_{2N}	
 <p>4AM32 to 4AM65 (≤ 2.5 kVA)</p>	400/230 \pm 15	24 42	4AM32 to 4AM65	400 V: 2-5 230 V: 2-4	1-5 1-4	3-5 3-4	24 V: 31-32 42 V: 31-32	--
 <p>4AM32 to 4AM65 (≤ 2.5 kVA)</p>	400/230 \pm 15	2 x 115	4AM32 to 4AM65, 4AT30 to 4AT39	400 V: 2-5 230 V: 2-4	1-5 1-4	3-5 3-4	230 V: 31-34 ²⁾ 115 V: 31-34 ²⁾	32-33 31-32; 33-34
 <p>4AT30 to 4AT39 (4 kVA ... 10 kVA)</p>								

¹⁾ For Cage Clamp terminals, the ground connection is routed to the terminal. The order of terminal assignments then changes as follows .
²⁾ Terminals 31–34 are duplicated in the Cage Clamp version.

Single-Phase Transformers

4AM, 4AT Safety, Isolating, Control and Mains Transformers

General data

In multi-voltage version

Circuit diagrams and terminal assignments	Rated input voltage U_{1N}	Rated output voltage U_{2N}	Connections and links			Secondary		
			Primary Rated voltage V	Terminals	Links	Rated voltage V	Terminals	Links
$U_{1N} = 550-525-500-480-460-440-415-400-380-230-208$								
<p>4AM32, 4AM34 (0.063 kVA; 0.1 kVA)</p> <p>NSF00143</p>	550-525-500-480-460-440-415-400-380-230-208	2 × 115	550	1-7	--	230 115	31-34	32-33 31-32; 33-34
<p>4AM32, 4AM34 (0.063 kVA; 0.1 kVA)</p> <p>NSF00144</p>			24	525 500 480 460 440 415 400 380 230 208	2-7 3-7 1-6 2-6 3-6 1-5 2-5 3-5 2-4 3-4			
<p>4AM32, 4AM34 (0.063 kVA; 0.1 kVA)</p> <p>NSF00144</p>		42			42	31-32	--	
<p>4AM38 to 4AM65 (0.16 kVA ... 2.5 kVA)</p> <p>NSF00145b</p>	550-525-500-480-460-440-415-400-380-230-208	2 × 115	550	1-8	4-5	230 115	31-34	32-33 31-32; 33-34
<p>4AT30 to 4AT39 (4 kVA ... 10 kVA)</p> <p>NSF0_00147a</p>			24	525 500 480 460 440 415 400 380 230 208	3-5 2-5 4-6 3-6 3-7 2-6 2-7 1-6; 4-8 1-7; 3-8			
<p>4AM38 to 4AM65 (0.16 kVA ... 2.5 kVA)</p> <p>NSF00146</p>		42			42	31-32	--	
$U_{1N} = 600-575-550-525-500-480-460-440-415-400-240-230$								
<p>4AM32, 4AM34 (0.063 kVA; 0.1 kVA)</p> <p>NSF00143</p>	600-575-550-525-500-480-460-440-415-400-240-230	2 × 115	600	1-7	--	230 115	31-34	32-33 31-32; 33-34
<p>4AM32, 4AM34 (0.063 kVA; 0.1 kVA)</p> <p>NSF00144</p>			24	575 550 525 500 480 460 440 415 400 240 230	2-7 3-7 1-6 2-6 3-6 1-5 2-5 3-5 3-5 1-4 2-4			
<p>4AM32, 4AM34 (0.063 kVA; 0.1 kVA)</p> <p>NSF00144</p>		42			42	31-32	--	
<p>4AM38 to 4AM65 (0.16 kVA ... 2.5 kVA)</p> <p>NSF00145b</p>	600-575-550-525-500-480-460-440-415-400-240-230	2 × 115	600	1-8	4-5	230 115	31-34	32-33 31-32; 33-34
<p>4AT30 to 4AT39 (4 kVA ... 10 kVA)</p> <p>NSF0_00147a</p>			24	575 550 525 500 480 460 440 415 400 240 230	3-5 3-6 3-7 2-5 2-6 2-7 1-7; 3-8 1-7; 3-8			
<p>4AM38 to 4AM65 (0.16 kVA ... 2.5 kVA)</p> <p>NSF00146</p>		42			24	31-32	--	

Single-Phase Transformers

4BT Power Transformers

General data

Overview

4BT.. transformers

With the right transformer, the right voltage will be available at any conditions.

Our transformers are the right choice for each application: They work reliably, safely and worldwide under a wide range of different conditions.

The 4BT single-phase power transformers can be configured as matching, auto- or converter transformers according to DIN VDE 0532-6 with selectable input and output voltages.

Our transformers provide optimal protection through high permissible ambient temperatures of up to 55 °C.

Design

Standards

DIN VDE 0532-6

Rated power P_n at high ambient temperature – the characteristic for thermal load capacity

Reference conditions under which the transformers have the rated power P_n stated in the selection tables:

- Uninterrupted duty P_n
- Frequency AC 50 Hz ... 60 Hz
- Degree of protection IP00
- Installation height up to 1000 m above sea level and
- Ambient temperature t_a , type-dependent 40 °C or 55 °C.

Other installation and operating conditions than this will affect the permissible permanent load capacity. In the case of the 4BT transformers, for example, with a low ambient temperature of 40 °C instead of 55 °C, an increase in load of 8% is possible (see [load characteristics](#)).

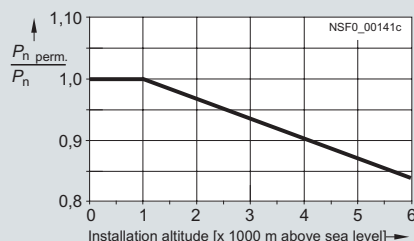
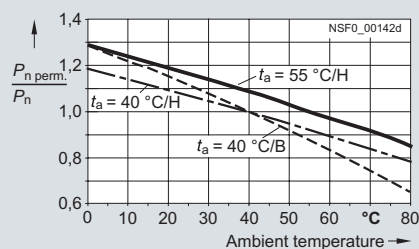

Load characteristics: Permissible transformer permanent load in relation to the ambient temperature and the installation height

Design

Standard version

All 4BT transformers are supplied for screw fixing on a mounting plate.

Terminals

Screw terminals

The 4BT transformers are supplied for rated currents up to 81 A in the standard version with screw terminals.

For higher currents, the transformers are supplied with flat connectors or with threaded bolts.

Enclosure mounting

4BT transformers are also available in protective enclosures of the degree of protection IP20 and IP23.

Required specifications for requests and orders for 4BT transformers with selectable voltages

Rated power P_n (output division with separate SEC windings, $P_n = P_1 + P_2$, throughput rating = load rating for autotransformers), PRI and SEC voltages, frequency, vector group, degree of protection (power reduction with degrees of protection other than IP00), Order No. stem.

The Order No. stem is added to the Order No. for delivery.

Example:

Single-phase transformer with selectable voltages 160 kVA
PRI 415 V \pm 5 %, SEC 115 V,
frequency 50 Hz ... 60 Hz,
degree of protection IP00,
shield winding,
Order No. stem 4BT62 1.

4BT autotransformers: determine the type rating P_n req.

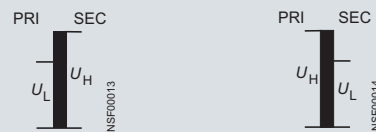

$$P_n \text{ req.} = P_n \text{ load.} \cdot \frac{U_H - U_L}{U_H}$$

(the single-phase example also applies for three-phase autotransformers)

Step-up transformer (left) and step-down transformer (right)

Thermistor transformer protection for 4BT power transformers

The windings of the power transformers can be protected from impermissible overheating by means of thermistor transformer protection. PTC thermistors are used which are wound into each shank of the transformer and connected in series. The rated response temperature is slightly above the limit temperature for uninterrupted duty.

Possible versions:

- Warning
- Disconnection
- Warning and disconnection

The connections for the temperature sensor are routed to terminals, two terminals each for warning and disconnection.

The 3RN tripping units are not included in the transformer scope of supply, for the relevant selection and ordering data see [Catalog LV 1, Chapter 7 "Monitoring and Control Devices"](#) -> "Monitoring Relays" -> "Thermistor Motor Protection".

Single-Phase Transformers

4BT Power Transformers

General data

Technical specifications

Transformers	Type	4BT
• Version		UI core
• Performance range (with IP00)	kVA	> 16 ... 250
• Approvals		cULus
Voltage range	V	≤ 1000 (up to 3.6 kV on request)
• Approvals for USA, Canada	V	≤ 600
Rated frequency	Hz	50 ... 60
Thermal class		H
• Acc. to UL/CSA		Class 180
Ambient conditions	Protection against harmful ambient conditions: complete impregnation in polyester resin Climate-proof for installation in rooms with an external climate to DIN 50010	
Rated ambient temperature		
• At rated power	°C	55
• Maximum value (after power reduction depending on load characteristics, see "Design")	°C	80
• Minimum value	°C	-25
Relative air humidity		
• Mean value up to	%	80
• Maximum value for 30 days/year	%	95
• At 40 °C occasionally	%	100
Protection class		I
Degree of protection		
• Without enclosure		IP00
• With protective enclosure (acc. to "Selection and ordering data", see Catalog LV 1)		IP20 or IP23
• Version		IP20, IP23: sheet-steel enclosure coated with epoxy resin, color gray RAL 7032
Installation height		Up to 1000 m above sea level (above this, power reduction is necessary)
Protective devices		
• Internal		Can be designed with thermistor transformer protection for warning or disconnection, or warning and disconnection, see "Design".
• External		The transformers can be protected against short-circuits and overload on the primary or secondary side with circuit breakers. For reliable protection against short-circuits and touch, the cables between the output terminals of the transformer and the load must have a negligible line impedance. For more details see DIN VDE 0100 (Erection of low-voltage systems) Part 410, Part 520 (particularly section 525) and part 600 (similar to IEC 60364-4-41, -5-52 and -6). On request
Connection methods		The permissible conductor cross-sections are assigned to the specified terminal types.
• Terminal arrangement		Refer to DIN VDE 0298-4 and EN 60204 for the permissible conductor cross-sections for the specified current according to the installation type. The terminals used are finger-safe according to EN 50274.
• For terminal versions and connectable cross-sections (see "Project planning aids")		Other terminal sizes than standard versions on request.
Mounting position		The permissible mounting position for each version is shown in the "Project planning aids".

Selecting the fuse

Short-circuit protection on the primary or secondary side using DIAZED or LV HRC fuses with characteristic gL/gG for 4BT45 to 4BT65 power transformers in the performance range from 18 kVA to 250 kVA.

Determining the fuse size:

$$\text{Rated current } I_n = \frac{\text{Rated power } P_n}{\text{Rated voltage } U_{1N}}$$

Minimum fuse current = Rated current x 1.2
Maximum fuse current = Rated current x 1.5

Example:

4BT59 power transformer,
degree of protection IP00,
rated power $P_n = 100$ kVA,
rated voltage $U_{1N} = 400$ V,
rated current $I_n = ?$

$$I_n = \frac{P_n}{U_{1N}} = \frac{100000 \text{ VA}}{400 \text{ V}} = 250 \text{ A}$$

Minimum fuse current = 250 A x 1.2 = 300 A
Maximum fuse current = 250 A x 1.5 = 375 A

Selected fuse size: 315 A

Further technical specifications can be found on the Internet at <http://www.siemens.com/sirius-supplying>.

Single-Phase Transformers

4BT Power Transformers

General data

Operation characteristics

- According to DIN VDE 0532-6
- $t_a = 55 \text{ °C/H}$

Transformers	Rated power P_n 50 Hz ... 60 Hz 1000 m above sea level Degree of protection IP00 Type kVA	Core size	Voltage rise in no-load operation (operating temperature) u_A approx. %	Voltage drop on rated load ¹⁾ u_R approx. %	Short-circuit voltage ¹⁾ u_Z approx. %	Degree of efficiency η approx. %
4BT45 0	18	UI 240/107	2.7	2.6	2.7	97
4BT47 0	20	UI 240/137	2.6	2.5	2.5	97
4BT47 1	22.5	UI 240/137	2.3	2.2	2.5	97
4BT47 2	25	UI 240/137	2.1	2	2.1	97
4BT51 0	28	UIS 265/107	4.3	4.1	4.8	95
4BT52 0	31.5	UIS 265/120	3.9	3.8	4.4	96
4BT53 0	35.5	UIS 265/135	3.6	3.5	4.1	96
4BT54 0	40	UIS 305/125	3.7	3.5	3.9	96
4BT54 1	45	UIS 305/125	3.3	3.2	3.8	96
4BT55 0	50	UIS 305/140	3.1	2.9	3.5	97
4BT56 0	63	UIS 305/160	2.5	2.5	3.2	97
4BT58 1	80	UIS 370/150	3.1	3	3.9	97
4BT59 0	100	UIS 370/170	2.6	2.5	3.7	97
4BT60 1	125	UIS 370/195	2.1	2.1	3.6	97
4BT62 1	160	UIS 455/175	2.1	2	3.7	98
4BT63 0	200	UIS 455/200	1.7	1.7	3.7	98
4BT65 0	250	UIS 455/260	1.5	1.5	3	98

Higher ratings and other conditions on request.

Calculation of power loss P_V

$$P_V = \frac{P_n (100 - \eta)}{\eta} \text{ [kW]}$$

¹⁾ Winding reference temperature: 115 °C.

Single-Phase Transformers

4AX22, 4AX23 Safety Transformers

Resin-enclosed

Overview

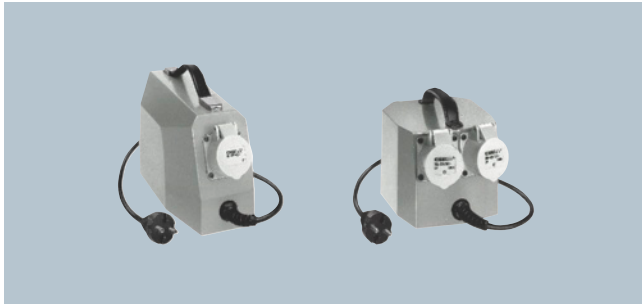

4AX22 12 (left) and 4AX22 14 (right)

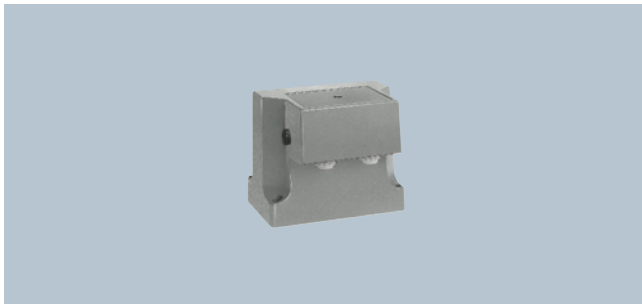

4AX23 11

The 4AX22 and 4AX23 safety transformers are resin-enclosed.

- Protection class II (For more safety transformers, see "Safety, Isolating, Control and Mains Transformers")
- Vector group II0
- Conditionally short-circuit resistant
- $t_a = 40\text{ °C/E}$

4AX22 portable version

- Highly rugged
- Degree of protection IP44
- EN 61558-2-6, -2-9
-

4AX23 stationary version

- Degrees of protection IP44 and IP65
- EN 61558-2-6
-



Design

The 4AX22 and 4AX23 single-phase safety transformers are fully resin-enclosed.

4AX22 portable version

These devices are characterized by extreme ruggedness.

There is a connecting cable with a vulcanized power plug on the input side. The secondary connection can be fitted with one or two CEE socket outlets according to the rating. The output plugs are supplied loose with the safety transformer.

A primary fuse that can be replaced from the outside protects against short-circuit and overload. The carrying handle makes it easy to move the unit around. The transformer is equipped with rubber feet that prevent slipping and absorb shocks.

4AX23 stationary version

The device contains one cable gland each with strain relief for the input and for the output.

A primary fuse that can be replaced, protects against short-circuits and overload. Mounting holes in the enclosure make mounting easy.

The safety transformers can be supplied in a special version with a CEE socket outlet. This reduces the degree of protection from IP65 to IP44. The output plug is supplied loose with the safety transformer.

Technical specifications

Transformers	Type	4AX22	4AX23
• Version		Resin-enclosed, portable	Resin-enclosed, stationary
• Performance range (with IP00)	kVA	0.1 ... 1	0.1 ... 1
Voltage range	V	≤ 230	
Rated frequency	Hz	50 ... 60	
Thermal class		E	
Ambient conditions		For external climate acc. to DIN 50010	
Rated ambient temperature			
• At rated power	°C	+40	
• Maximum value	°C	+60	
• Minimum value	°C	-25	
Protection class		II	
Degree of protection		IP44	IP44, IP65
Installation height		Up to 1000 m above sea level	
Protective devices, internal		Fuse links: G up to 5 A, D01 up to 16 A	G up to 6.3 A, D01 up to 16 A
Connection methods		See "Selection and ordering data" in Catalog LV 1	
Mounting position		Any position	

Single-Phase Transformers

4AX24 Isolating Transformers

Resin-enclosed

Overview



4AX24 13

The 4AX24 portable isolating transformers are completely resin-enclosed.

- EN 61558-2-4
-
- $t_a = 40\text{ °C/E}$
- Degree of protection IP44
- Protection class II (For more safety transformers, see "Safety, Isolating, Control and Mains Transformers")
- Vector group II0
- Conditionally short-circuit resistant



Design

The 4AX24 single-phase isolating transformers are completely resin-enclosed.

There is a connecting cable with a vulcanized rubber plug on the input side. The secondary connection is designed as a two-pole socket outlet with a hinged lid (without grounding contact).

A primary fuse that can be replaced from the outside protects against short-circuit and overload.

The carrying handle makes it easy to move the unit around. The transformer is equipped with rubber feet that prevent slipping and absorb shocks.

Technical specifications

Transformers	Type	4AX24
• Version		Resin-enclosed, portable
• Performance range (with IP00)	kVA	0.16 ... 2.5
Voltage range	V	≤ 230
Rated frequency	Hz	50 ... 60
Thermal class		E
Ambient conditions		For external climate acc. to DIN 50010
Rated ambient temperature		
• At rated power	°C	+40
• Maximum value	°C	+60
• Minimum value	°C	-25
Protection class		II
Degree of protection		IP44
Installation height		Up to 1000 m above sea level
Protective devices, internal		Fuse links: G up to 10 A, D01 up to 16 A
Connection methods		See "Selection and ordering data" in Catalog LV 1
Mounting position		Any position

Single-Phase Transformers

4AT Isolating Transformers

For supply of medical premises

Overview

- According to EN 61558-2-15
- Protection class I
- With static shield between the primary and secondary winding with insulated connection
- With thermistor transformer protection for warning of thermal overload¹⁾
- With central tap for insulation monitoring
- Short-circuit voltage $u_z \leq 3\%$
- No-load supply current $i_0 \leq 3\%$
- Inrush current max. $8 \times I_{1N}$
- $t_a = 55\text{ °C/H}$



4AT special version for medical premises

¹⁾ 3RN tripping units for PTC sensors must be ordered separately, see Chapter 7, "Monitoring and Control Devices".

Technical specifications

Transformers	Type	4AT
• Version		UI core
• Performance range (with IP00)	kVA	> 2.5 ... 8
Voltage range	V	230
Rated frequency	Hz	50 ... 60
Thermal class		H
Ambient conditions		Protection against harmful ambient conditions: complete impregnation in polyester resin Climate-proof for installation in rooms with an external climate to DIN 50010
Rated ambient temperature		
• At rated power	°C	55
Relative air humidity		
• Mean value up to	%	80
• Maximum value for 30 days/year	%	95
• At 40 °C occasionally	%	100
Protection class		I
Degree of protection		
• Without enclosure		IP00
• With protective enclosure (acc. to "Selection and ordering data", see Catalog LV 1)		IP23
• Version		IP23: sheet-steel enclosure coated with epoxy resin, color gray RAL 7032
Installation height		Up to 1000 m above sea level (above this, power reduction is necessary)
Protective devices		
• Internal		With thermistor transformer protection for warning
• External		The transformers have to be protected against short-circuits on the secondary side with circuit breakers (see "Selection and ordering data" in the Catalog LV 1). For reliable protection against short-circuits and touch, the cables between the output terminals of the transformer and the load must have a negligible line impedance. For more details see DIN VDE 0100 (Erection of low-voltage systems) Part 410, Part 520 (particularly section 525) and part 600 (similar to IEC 60364-4-41, -5-52 and -6) . Assigned protective devices (see "Selection and ordering data" in Catalog LV 1)
Connection methods		
• Terminal arrangement		The permissible conductor cross-sections are assigned to the specified terminal types. Refer to DIN VDE 0298-4 and EN 60204 for the permissible conductor cross-sections for the specified current according to the installation type. The terminals used are finger-safe according to EN 50274.
Mounting position		Any position

Further technical specifications can be found on the Internet at <http://www.siemens.com/sirius-supplying>.

Schematics

Circuit diagram and terminal assignment

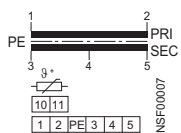

Insulation monitoring: terminal 4
PTC sensors: terminal 10-11
Shield winding: PE terminal (insulated)

Rated input voltage U_{1N}	Rated output voltage U_{2N}	Connections and links		
		Transformer type	Primary U_{1N}	Secondary U_{2N}
V	V	4AT	1-2	3-5 4
230	230 115			

Single-Phase Transformers

4FL, 4FK Voltage Regulators

4FL voltage regulators, transformer type

Overview



4FL

- According to DIN VDE 0552
- Degree of protection IP21
- $t_a = 40\text{ °C/E}$

Design

The transformer-type voltage regulator supplies electrical loads with a constant voltage despite mains variations.

The advantage of a voltage regulator with a variable-ratio transformer is proportional changing of the sinewave, i. e. the voltage regulator is characterized in that the rms value, mean value and the peak value are held at constant ratios.

A perfect rms value is required, for example, by loads for which the loading is determined by the thermal limits. Strongly capacitive loads in DC units respond to the mean value. A slightly capacitive load is, however, influenced by the peak value. These factors are, however, only guaranteed for sinusoidal AC voltages and this can only be achieved easily by means of a variable-ratio transformer.

Voltage regulators stabilize the mains voltage U_1 regardless of the frequency and power factor to the rated value of output voltage U_{2N} within the set control accuracy ($\pm 1\%$ of U_{2N}). The correcting time from the upper or lower limit to the rated value is between 1.5 s and 2.5 s. The curve shape of the supplied voltage is not changed.

The output voltage U_2 is compared in the electronic step controller with a set reference voltage. In the event of a deviation in voltage greater than the set response value, the electronic step controller compensates the deviation with an accuracy of $\pm 1\%$ using a servo motor and adjustable moving contact on the variable-ratio transformer.

Transformer-type voltage regulators:

- Are electrically connected to the network
- Can be overloaded temporarily (see [characteristic curve](#))
- Can be installed in a sheet-steel enclosure to IP21 complete with any additional components
- Have a degree of efficiency of between 95 % and 98 %
- Are not maintenance-free
- For the values for control range and control deviation, see "Selection and ordering data" in [Catalog LV 1](#).

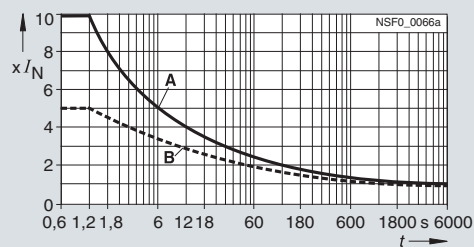

Reference temperature:

Curve A: winding temperature = ambient temperature
Curve B: winding temperature = operating temperature

Overload capability (guide values)

Ambient conditions

4FL transformer-type voltage regulators are climate proof for installation in rooms with an internal climate according to DIN 50010.

Limit values:

- Ambient temperature at
 - Rated power +40 °C,
 - Minimum value -25 °C.
- Relative air humidity
 - At 40 °C up to 85 %,
 - Annual average up to 65 %
 - Condensation not permitted

Short-circuit and overload protection

Transformer-type voltage regulators must be protected with gL/gG fuses on the primary side against damage caused by short-circuits. The fuse rated current must be determined according to the highest primary current (present with the lowest input voltage). Overload and short-circuit protective devices according to the rated load current must be provided on the output side. An overload relay is integrated in the control circuit, the trip contacts (break or make) must be connected on a switch that automatically disconnects the transformer voltage regulator from the network in the event of a fault.

Single-Phase Transformers

4FL, 4FK Voltage Regulators

4FK voltage regulators, magnetic type

Overview

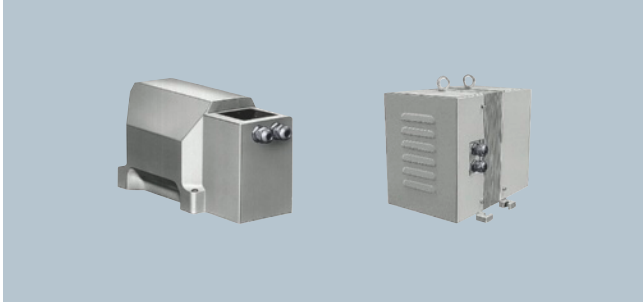

4FK31 to 4FK34 (figure on the left) and 4FK35 to 4FK38 (figure on the right)

- According to EN 61558-2-12
- With sinusoidal output voltage
- Settling time 40 ms
- $t_a = 40\text{ °C}$



Design

The correcting time for the voltage regulators is about 40 ms, whereby they can bridge mains voltage interruptions of up to a half-wave. The stabilizing effect is based on a tuned anti-resonant circuit with an iron-core reactor that is forced into saturation (see Schematics). This iron-core reactor is responsible for the distorted output voltage (harmonic distortion from 3 % to 4 %). Magnetic type voltage regulators are frequency dependent due to the anti-resonant circuit.

Voltage regulators are designed for resistive loads and harmonized. If the load has a power factor that lies outside the specification, the output voltage will be reduced for an inductive load and increased for a capacitive load. Inductive loads can be compensated by using appropriate compensation capacitors. It is also possible to construct voltage regulators that are adapted to a different power factor.

Magnetic type voltage regulators have outputs that are short-circuit resistant, i. e. when the outputs are short-circuited, the current rises to 1.3 to 1.5 times the value. The input current only changes insignificantly. Due to this characteristic, a voltage stabilizer cannot rupture a melting fuse. The load can be protected by a motor-protective circuit breaker at the output that is set to rated current. Magnetic type voltage regulators have, as a result of the high inductance in the iron core, inrush currents between 10 times and 30 times the rated current. For this reason, a slow-acting line fuse should be used at the input.

The characteristics of magnetic type voltage regulators can be summarized as follows:

- Settling of mains voltage variations.
- Maintaining the output voltage at a constant value despite load variations.
- Electrical isolation of the output voltage from the input voltage, transformation of the input voltage to the required output voltage.
- Limitation of the output current in the event of an overload or short-circuit to approximately 1.3 or $1.6 \times I_n$ (see Current/voltage characteristic curve), short-circuit resistant.
- Filtering of high-frequency faults (damping of 35 dB up to 100 kHz) and suppression of voltage peaks. Filtering of distorted input voltages, harmonic distortion factor of the output from 3 % to 4 % at rated load.

- Maintenance-free
- No moving parts
- Bridges mains voltage interruptions of up to a half-wave
- Due to the anti-resonant circuit, magnetic type voltage regulators are frequency-dependent

It must be taken into account that the operating temperature and the noise generation is higher for a magnetic type voltage stabilizer than for an isolating transformer.

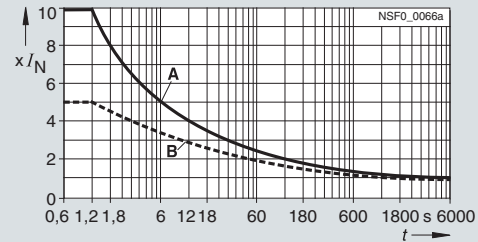

Reference temperature:

Curve A: winding temperature = ambient temperature
Curve B: winding temperature = operating temperature

Overload capability (guide values)

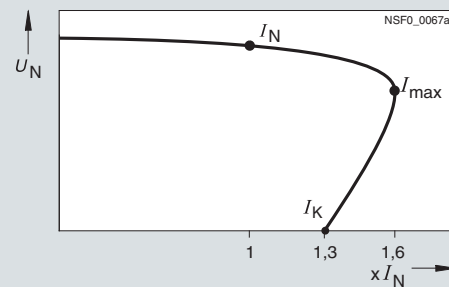

Current/voltage characteristic curve

Ambient conditions

4FK magnetic type voltage regulators are climate proof for installation in rooms with an internal climate according to DIN 50010.

Limit values:

- Ambient temperature at
 - Rated power $+40\text{ °C}$,
 - Minimum value -25 °C .
- Relative air humidity
 - At 40 °C up to 100 %,
 - Annual average up to 85 %
 - Condensation not permitted

Schematics

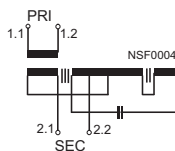

Single-Phase Transformers

Project planning aids

Dimensional drawings

4AM, 4AT safety, isolating, control and mains transformers < 16 kVA

4AM safety, isolating, control and mains transformers < 16 kVA and 4AM safety, isolating, control and mains transformers and autotransformers with selectable voltages < 16 kVA

4AM23 to 4AM65

for any mounting position

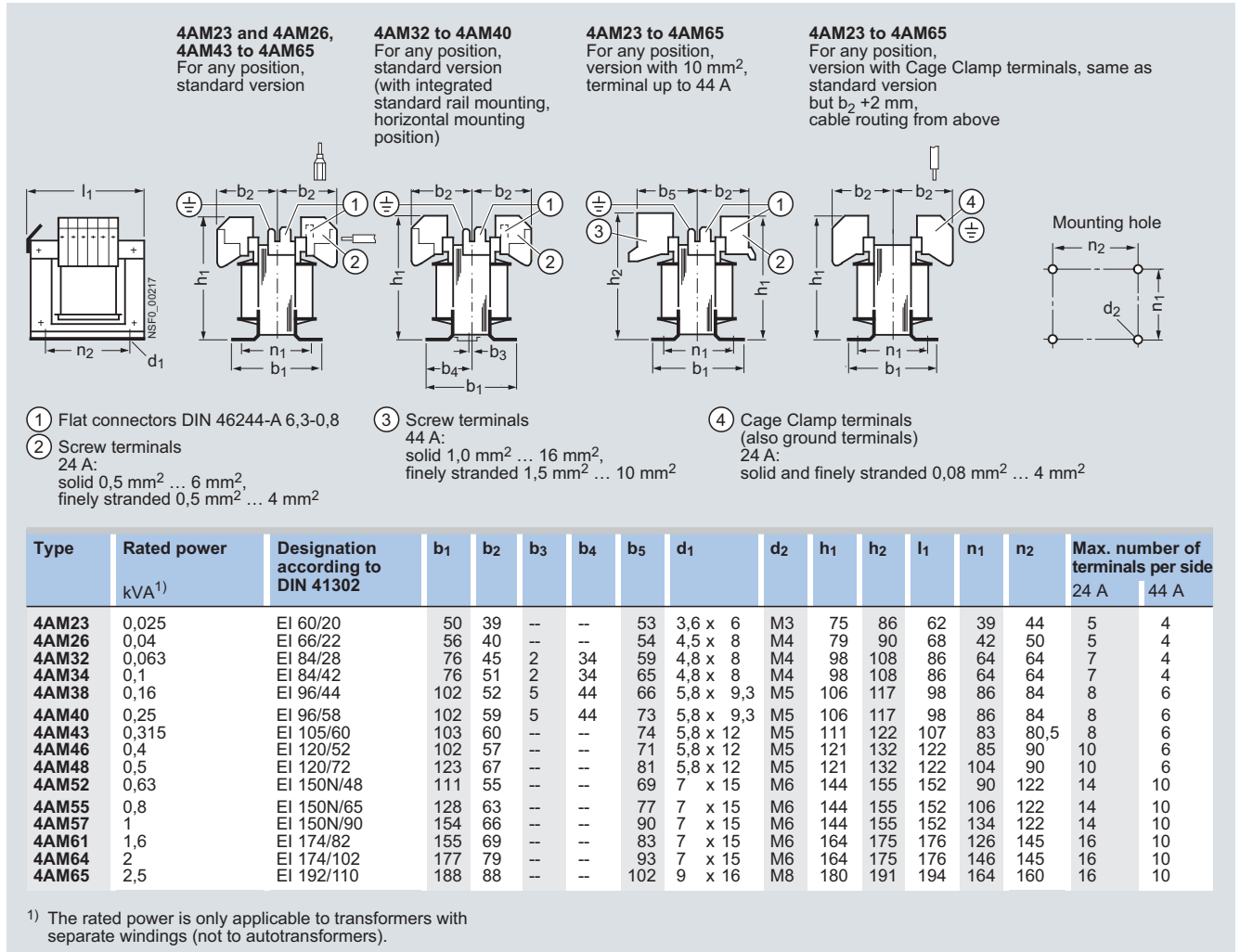

4AM, 4AT safety, isolating, control and mains transformers < 16 kVA (continued)**4AM23 to 4AM65**

for any mounting position, with terminals ≤ 60 A
by means of terminal strip

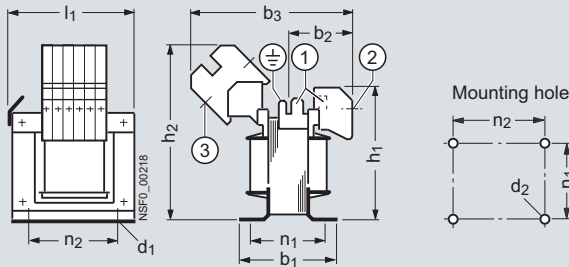

- ① Flat connectors DIN 46244-A 6,3-0,8
- ② Screw terminal
24 A:
solid 0,5 mm² ... 6 mm²,
finely stranded 0,5 mm² ... 4 mm²
- ③ Screw terminal
60 A:
solid 1,0 mm² ... 16 mm²,
stranded 10 mm² ... 25 mm²,
finely stranded 2,5 mm² ... 16 mm²
> 61 A:
[see flat connectors](#)

Type	Rated power kVA ¹⁾	Designation according to DIN 41302	b ₁	b ₂	b ₃	d ₁	d ₂	h ₁	h ₂	l ₁	n ₁	n ₂	Max. number of terminals per side	
													24 A	60 A
4AM23	0,025	EI 60/20	50	39	102	3,6 x 6	M3	75	104	62	39	44	5	4
4AM26	0,04	EI 66/22	56	40	104	4,5 x 8	M4	79	108	68	42	50	5	4
4AM32	0,063	EI 84/28	76	45	112	4,8 x 8	M4	98	127	86	64	64	7	4
4AM34	0,1	EI 84/42	76	51	126	4,8 x 8	M4	98	127	86	64	64	7	4
4AM38	0,16	EI 96/44	102	52	128	5,8 x 9,3	M5	106	135	98	86	84	8	6
4AM40	0,25	EI 96/58	102	59	142	5,8 x 9,3	M5	106	135	98	86	84	8	6
4AM43	0,315	EI 105/60	103	60	143	5,8 x 12	M5	111	140	107	83	80,5	8	6
4AM46	0,4	EI 120/52	102	57	137	5,8 x 12	M5	121	150	122	85	90	10	6
4AM48	0,5	EI 120/72	123	67	157	5,8 x 12	M5	121	150	122	104	90	10	6
4AM52	0,63	EI 150N/48	111	55	134	7 x 15	M6	144	173	152	90	122	14	8
4AM55	0,8	EI 150N/65	128	63	152	7 x 15	M6	144	173	152	106	122	14	8
4AM57	1	EI 150N/90	154	66	176	7 x 15	M6	144	173	152	134	122	14	8
4AM61	1,6	EI 174/82	155	69	165	7 x 15	M6	164	192	176	126	145	16	10
4AM64	2	EI 174/102	177	79	185	7 x 15	M6	164	192	176	146	145	16	10
4AM65	2,5	EI 192/110	188	88	203	9 x 16	M8	180	208	194	164	160	16	10

¹⁾ The rated power is only applicable to transformers with separate windings (not to autotransformers).

Standard rail mounting for 4AM transformers in a special version with a preassembled adapter plate

For horizontal mounting position

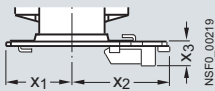

4AM32, 4AM34, 4AM38 and 4AM40 transformers are supplied as standard for both screw mounting and with integrated standard rail mounting, see dimensional drawings 4AM.

If using standard rail mounting, the mounting position is horizontal.

Type	x ₁ max.	x ₂ max.	x ₃	Stand. mount. rail mm
4AM23	b ₁ /2 +2	b ₁ /2 +21	9	35 x 7,5
4AM26	b ₁ /2 +5	b ₁ /2 +21	9	35 x 7,5
4AM43	b ₁ /2 +3	b ₁ /2 +8	15	35 x 15
4AM46 to 4AM48	b ₁ /2 +3	b ₁ /2 +3	15	35 x 15

Single-Phase Transformers

Project planning aids

4AM, 4AT safety, isolating, control and mains transformers < 16 kVA (continued)

4AT safety, isolating, control and mains transformers < 16 kVA and

4AT safety, isolating, control and mains transformers and transformers with selectable voltages < 16 kVA

4AT30 to 4AT43

for any mounting position

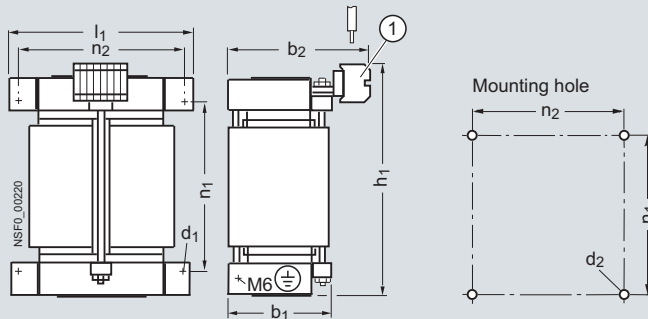

① Screw terminal

- 18 A:
solid 0,5 mm² ... 6 mm²,
finely stranded 0,5 mm² ... 4 mm²
- 23 A:
solid 0,75 mm² ... 10 mm²,
finely stranded 1,5 mm² ... 6 mm²
- 43 A:
solid 1,0 mm² ... 16 mm²,
stranded 10 mm² ... 25 mm²,
finely stranded 2,5 mm² ... 16 mm²
- 81 A:
solid 4,0 mm² ... 16 mm²,
stranded 10 mm² ... 50 mm²,
finely stranded 6 mm² ... 35 mm²

> 81 A:
see flat-type and threaded pin terminals

Permissible permanent load for 4AT36 and 4AT39 for arrangement on horizontal surfaces:

$$0,95 \cdot P_n \text{ at } t_a = 55 \text{ }^\circ\text{C}$$

$$P_n \text{ at } t_a = 45 \text{ }^\circ\text{C}$$

Type	Rated power kVA ¹⁾	Designation according to DIN 41302	b ₁	b ₂	d ₁	d ₂	h ₁	l ₁	n ₁	n ₂	Max. number of terminals per side			
											18 A	23 A	43 A	81 A
4AT30	4	UI 150/75	147	205	9 x 14	M8	263	214	200	190	20	18	13	8
4AT36	5; 6,3	UI 180/75	180	238	9 x 14	M8	315	244	240	220	24	22	16	10
4AT39	8; 10	UI 210/70	185	243	11 x 16	M10	365	285	280	260	29	26	19	11
4AT43	12,5; 14	UI 240/80	195	253	11 x 16	M10	415	325	320	290	33	33	22	13

¹⁾ The rated power is only applicable to transformers with separate windings (not to autotransformers).

4AT30 to 4AT43

for arrangement on horizontal surfaces, special constructions can only be supplied for transformers with selectable data

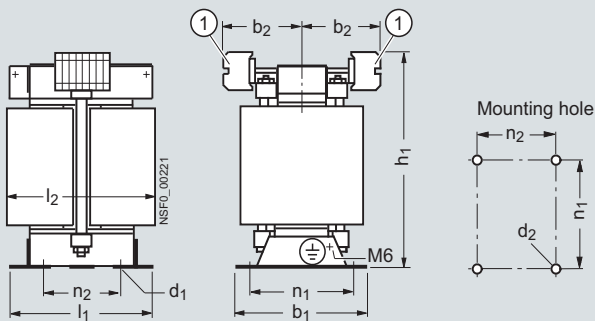

① Screw terminal

- 18 A:
solid 0,5 mm² ... 6 mm²,
finely stranded 1,5 mm² ... 4 mm²
- 23 A:
solid 0,75 mm² ... 10 mm²,
finely stranded 1,5 mm² ... 6 mm²
- 43 A:
solid 1,0 mm² ... 16 mm²,
stranded 10 mm² ... 25 mm²,
finely stranded 2,5 mm² ... 16 mm²
- 81 A:
solid 4,0 mm² ... 16 mm²,
stranded 10 mm² ... 50 mm²,
finely stranded 6 mm² ... 35 mm²

> 81 A:
see flat-type and threaded pin terminals

Type	Rated power kVA ¹⁾	Designation according to DIN 41302	b ₁ max.	b ₂ min.	b ₂ max.	d ₁	d ₂	h ₁ max.	l ₁	l ₂ max.	n ₁	n ₂	Max. number of terminals per side			
													18 A	23 A	43 A	81 A
4AT30	4	UI 150/75	155	109	117	10 x 18	M8	270	164	200	118	124	20	18	13	8
4AT36	5; 6,3	UI 180/75	169	114	122	10 x 18	M8	320	194	240	138	144	24	22	16	10
4AT39	8; 10	UI 210/70	174	111	119	12 x 18	M10	370	226	280	141	176	29	26	19	11
4AT43	12,5; 14	UI 240/80	194	116	124	15 x 22	M12	420	256	310	155	196	33	30	22	13

¹⁾ The rated power is only applicable to transformers with separate windings (not to autotransformers).

**4AT safety, isolating, control and mains transformers ≤ 16 kVA,
4BT power transformers ≥ 18 kVA**

**4AT safety, isolating, control and mains transformers and autotransformers with selectable voltages ≤ 16 kVA
4BT power transformers and autotransformers with selectable voltages ≥ 18 kV**

4AT45, 4BT45 to 4BT65
for arrangement on horizontal surfaces

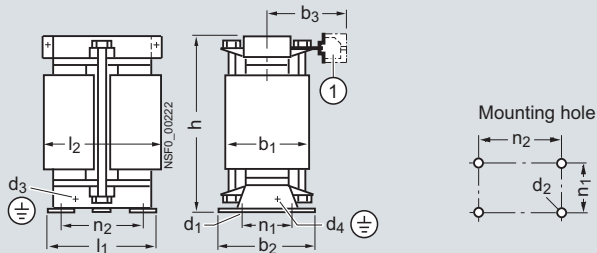

① Screw terminal

Terminal size	Screw terminal for cross-section			Current carrying capacity A
	solid mm ²	stranded mm ²	finely strand. mm ²	
4	0,5 ... 6	--	1,5 ... 4	18
6	2,5 ... 10	--	1,5 ... 6	23
16	1,5 ... 16	10 ... 25	4 ... 16	43
35	10 ... 16	10 ... 50	10 ... 35	81

> 81 A:
see flat-type and threaded pin terminals

Type	Rated power kVA ¹⁾	Type size in conformance with DIN 41302	b ₁	b ₂	b ₃ ± 3 with terminal size (4) 6 16 35			d ₁	d ₂	d ₃	d ₄	h	l ₁	l ₂	n ₁	n ₂	Max. number of terminals per side				
																		4	6	16	35

4AT safety, isolating, control and mains transformers and autotransformers with selectable voltages ≤ 16 kVA

4AT45	16	UI 240/107	221	221	126	134	146	15 x 22	M12	--	M6	420	256	320	182	196	33	30	22	13
--------------	----	------------	-----	-----	-----	-----	-----	---------	-----	----	----	-----	-----	-----	-----	-----	----	----	----	----

4BT power and autotransformers with selectable voltages ≥ 18 kVA

4BT45	18	UI 240/107	230	221	152	163	174	15	M12	--	M6	420	256	310	182	196	33	30	22	13
4BT47	20; 22,5; 25	UI 240/137	260	251	172	178	190	15	M12	--	M6	420	256	310	212	196	33	30	22	13
4BT51	28	UIS 265/107	267	207	147	155	167	12,5	M10	M12	--	515	285	370	170	225	--	36	26	16
4BT52	31,5	UIS 265/120	280	220	153	161	173	12,5	M10	M12	--	515	285	370	183	225	--	36	26	16
4BT53	35,5	UIS 265/135	295	235	161	169	181	15	M10	M12	--	515	285	370	198	225	--	36	26	16
4BT54	45	UIS 305/125	295	245	166	174	186	15	M12	M12	--	585	330	420	198	260	--	36	26	16
4BT55	50	UIS 305/140	310	260	173	181	193	15	M12	M12	--	585	330	420	213	260	--	36	26	16
4BT56	63	UIS 305/160	330	280	183	191	203	15	M12	M12	--	585	330	420	233	260	--	36	26	16
4BT58	80	UIS 370/150	330	290	180	188	200	15	M12	M12	--	665	400	520	241	320	--	46	32	20
4BT59	100	UIS 370/170	350	310	190	198	210	15	M12	M12	--	665	400	520	261	320	--	46	32	20
4BT60	125	UIS 370/195	375	335	203	211	223	15	M12	M12	--	665	400	520	286	320	--	46	32	20
4BT62	160	UIS 455/175	405	315	193	201	213	21	M16	M12	--	760	495	650	261	395	--	56	40	24
4BT63	200	UIS 455/200	430	340	205	213	225	21	M16	M12	--	760	495	650	298	395	--	56	40	24
4BT65	250	UIS 455/260	490	400	235	243	255	21	M16	M12	--	760	495	650	253	395	--	56	40	24

¹⁾ The rated power is only applicable to transformers with separate windings

Flat-type and threaded pin terminals

4AM, 4AT, 4BT flat connectors with through-hole

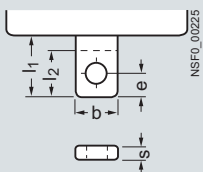

Flat connector on the transformer winding with through-hole for rail or cable lug. Terminal covers for protection against accidental contact, free busbar connections up to 800 A (DIN VDE 0106-100) must be ordered separately.

Type	Terminal size A	b = l ₂	With hole For screw	e	l ₁	s
4AM, 4AT, 4BT	100	16	M6	8	25	2,5
	200	20	M8	10	30	3
	400	25	M10	12,5	35	5
	630	30	M10	15	40	6
	800	30	M12	15	40	8
	1000	40	M12	20	50	8

For terminal covers, see Catalog LV 1, Chapter 3 "Controls – Contactors and Contactor Assemblies, Accessories and Components", Order No. depends on the 3TX6 5.6-3B flat connector.

Threaded bolts on 4AT, 4BT insulating strip

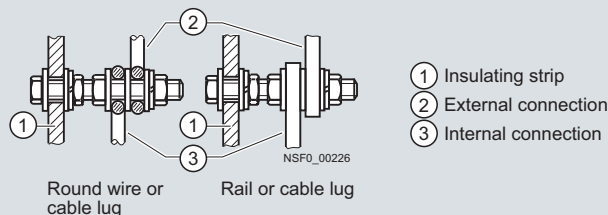

Type	Terminal size A	Threaded bolt	For conductor cross-sections mm ²
4AT, 4BT	200	M8	≤ 50
	315	M10	≤ 120
	500	M12	≤ 300

Single-Phase Transformers

Project planning aids

Protective enclosure with 4AM, 4AT safety, isolating, control and mains transformers ≤ 16 kVA, for degree of protection IP23 and IP54

4AM23 to 4AM65, 4AT30 to 4AT43 mounting positions

Type	Mounting position	Degree of prot.	
		IP23	IP54
4AM, 4AT30 to 4AT43 ¹⁾	horizontal	x	x
	vertical	x	x

x = permissible

Horizontal, with degree of protection IP54

Vertical, with degree of protection IP23 and IP54

1) The 4AT43 transformers are available only with degree of protection IP23.

Sheet-steel enclosure, epoxy-resin coated, for degree of protection IP23 and IP54¹⁾

4AM23 to 4AM65, 4AT30 to 4AT43

Type	a	b ₁	b ₂	b ₃	d ₁	d ₂	h ₁	h ₂	l ₁	l ₂	l ₃	n ₁	n ₂
4AM23 to 4AM34	2 x M25	112	149	--	5,8	--	135	35	155	35	--	125	137
4AM38 to 4AM57	2 x M25	187	224	--	5,8	--	230	42	245	35	--	200	212
4AM61 to 4AM65, 4AT30, 4AT36	2 x M32	305	351	--	9	--	330	56	395	45	--	335	333
4AT39, 4AT43 ¹⁾	2 x M32	395	460	50	13	35	465	60	555	45	50	480	430

1) The 4AT43 transformers are available only with degree of protection IP23.

Protective enclosure with dry transformers > 16 kVA, for degree of protection IP20 and IP23**Sheet-steel enclosure, epoxy-resin coated**
4AT45, 4BT45 to 4BT65

for arrangement on horizontal surfaces

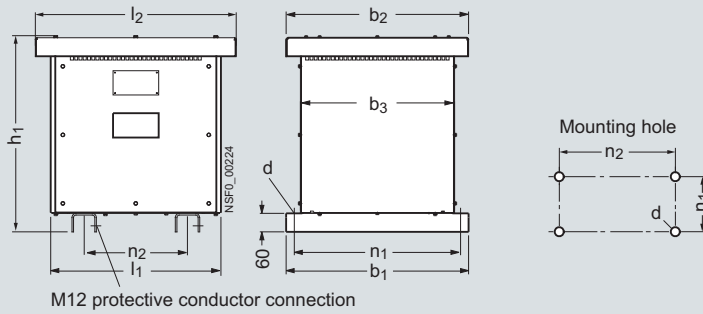

Type	b ₁	b ₂	b ₃	h ₁	d	l ₁	l ₂	n ₁	n ₂
4AT45, 4BT45 and 4BT47	600	600	507	645	15	560	660	570	340
4BT51 to 4BT53	600	600	507	735	15	560	660	570	316
4BT54 to 4BT56	600	600	507	825	15	800	900	570	465
4BT58 to 4BT60	730	730	637	905	19	1120	1220	696	630
4BT62 to 4BT65	900	900	807	1005	21	1120	1220	858	720

Single-Phase Transformers

Project planning aids

4AX22, 4AX23 safety transformers, resin-enclosed, 4AX24 isolating transformers, resin-enclosed

4AX23 10 to 4AX23 16
safety transformer, stationary,
 for mounting in any position, suitable for construction sites

① Fuse
 ② Cable gland
 ③ Version with CEE socket outlet

Type	P_n A	A	B	C	D	E	F
4AX23 10	0,1	115	130	100	64	115	5
4AX23 11	0,16	145	145	125	84	125	5
4AX23 13	0,25	168	145	125	108	125	5
4AX23 14	0,4	180	176	152	103	151	6
4AX23 15	0,63	200	176	152	120	151	6
4AX23 16	1	220	210	175	137	178	6

4AX22 12
safety transformer, portable,
 with 2 CEE socket outlets, suitable for construction sites

① Fuse
 ② Connecting cable 2.5 mm

Safety and isolating transformer, portable,
 suitable for construction sites

4AX22 10, 4AX22 14 to 4AX22 16
 with 1 CEE socket outlet,
4AX24 11 to 4AX24 18
 with 1 SCHUKO socket outlet

① Fuse
 ② Connecting cable 2.5 mm

Safety transformer Type	Isolating transformer Type	P_n A	A	B	C
4AX22 10	--	0,1	235	95	115
--	4AX24 11	0,16	235	95	115
--	4AX24 13	0,25	280	100	150
4AX22 14	4AX24 14	0,4	280	115	150
4AX22 15	4AX24 15	0,63	280	130	150
4AX22 16	4AX24 16	1	340	140	200
--	4AX24 17	1,6	340	160	200
--	4AX24 18	2,5	340	190	200

4AT isolating transformers for the supply of medical premises

4AT30 to 4AT36
 for any mounting position

① Screw terminal:
 solid 1,0 mm² ... 16 mm²,
 stranded 10 mm² ... 25 mm²,
 finely stranded 2,5 mm² ... 16 mm²,
 Terminal size 16

Type	P_n kVA	Design. according to DIN 41302	b_1	d_1	d_2	e	h_1 max.	l_1	n_1	n_2
4AT30	2,5	UI 150/75	155	10 x 18	M8	133	270	200	118	124
4AT36	3,15; 4	UI 180/75	169	10 x 18	M8	142	310	240	138	144
4AT39	5; 6,3	UI 210/70	174	12 x 18	M10	143	370	270	141	176
4AT43	8	UI 240/80	194	15 x 22	M10	148	415	300	155	196

4FL, 4FK voltage regulators**4FL voltage regulators, transformer type****4FL**

degree of protection IP21

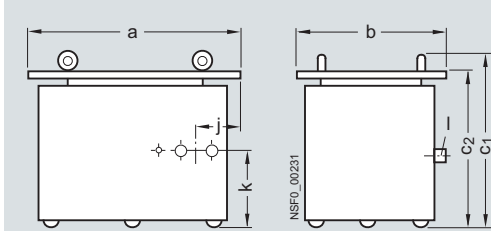

Type	a	b	c ₁	c ₂	j	k	l
4FL10 to 4FL14, 4FL16, 4FL17, 4FL20 to 4FL22, 4FL24, 4FL26, 4FL29	490	360	--	430	140	70	M25
4FL25, 4FL27, 4FL28, 4FL30 10, 4FL33, 4FL37	700	500	560	510	145	260	M50

4FL

degree of protection IP21

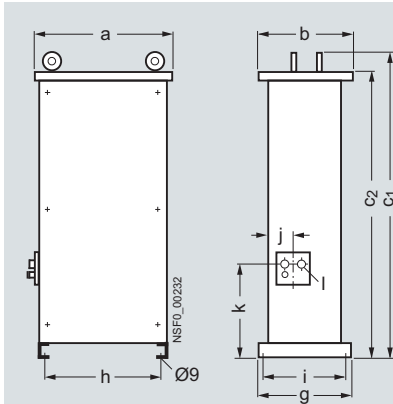

Type	a	b	c ₁	c ₂	g	h	i	j	k	l
4FL30 20, 4FL34	505	380	1065	1010	380	360	360	120	395	M50
4FL41	505	380	1065	1010	380	360	360	120	395	M63
4FL39, 4FL44, 4FL48	720	470	1355	1290	470	450	450	140	440	M63

Single-Phase Transformers

Project planning aids

4FK voltage regulators, magnetic type

4FK31 to 4FK34

degree of protection IP65, for any mounting position

Type	Rated power kVA	b ₁	d	h ₁	l ₁	n ₁	n ₂
4FK31	0,12	250	5	160	120	162	100
4FK32	0,25	305	5	170	140	200	118
4FK33	0,5	305	5	180	155	200	134
4FK34	0,75	320	6	185	185	198	166

4FK35 to 4FK38

degree of protection IP20, for any mounting position

Type	Rated power kVA	b ₁	d	h ₁	l ₁	n ₁	n ₂
4FK35	1	265	9	325	330	240	83
4FK36	1,5	265	9	325	345	240	96
4FK37	2	265	9	325	370	240	122
4FK38	2,5	265	9	325	415	240	167

4FK39 to 4FK44

degree of protection IP21, for horizontal mounting position

Three-Phase Transformers

4AP, 4AU Safety, Isolating, Control and Mains Transformers

General data

Overview

4AP./4AU.. transformers

With the right transformer, the right voltage will be available at any conditions.

Our transformers are the right choice for each application: They work reliably, safely and worldwide under a wide range of different conditions.

The transformers are configured in user-friendly combinations as isolating, control and mains transformers according to EN 61558-2-4, -2-2, -2-1, or as safety, control and mains transformers according to EN 61558-2-6, -2-2, -2-1, or as autotransformers according to EN 61558-2-13 with selectable input and output voltages.

Note:

Mains transformers with ≤ 50 V on the output side are, in the case of SIRIUS transformers, always designed as safety transformers.

Our transformers provide optimal protection through high permissible ambient temperatures up to 40 °C or 55 °C, a high short-time rating in the case of control transformers, fuseless construction and due to its safety standard "Safety inside" EN 61558.

Design

Standards

EN 61558-2-6, -2-4, -2-2, -2-1, -2-13

The standard EN 61558 is the European edition of the international standard IEC 61558 (Safety of power transformers, power supply units and similar).

Some of the transformers are subject to more stringent manufacturing and testing conditions in view of these changes.

Transformers for general applications always have double or reinforced insulation with SELV voltages (can be touched, maximum 50 V AC and 120 V DC), i. e. these transformers are exclusively safety transformers.

Furthermore, all transformers are supplied with information on the protective elements with which they are protected against short-circuit and overload.

The SIRIUS transformer series contains the combined features of safety, isolating, control and mains transformers, i. e. one transformer for (virtually) all applications. SIRIUS transformers comply with the highest requirements (and with regard to safety the most stringent requirements) of the transformer versions contained in this catalog. A SIRIUS transformer is the right one whatever the application.

Rated power P_n at high ambient temperature – the characteristic for thermal load capacity

Reference conditions under which the transformers have the rated power P_n stated in the selection tables:

- Uninterrupted duty P_n
- Frequency AC 50 Hz ... 60 Hz
- Degree of protection IP00
- Installation height up to 1000 m above sea level and
- Ambient temperature t_a , type-dependent 40 °C or 55 °C.

Other installation and operating conditions than this will affect the permissible permanent load capacity. In the case of the 4AP transformers, for example, with a low ambient temperature of 30 °C an increase in load of 8 % is possible (see "Load Characteristics").

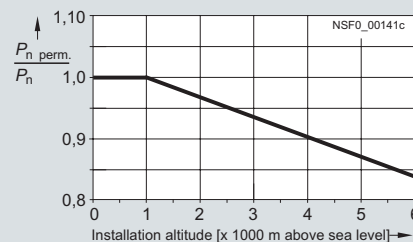
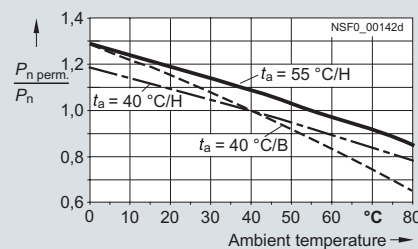

Load characteristics: Permissible transformer permanent load in relation to the ambient temperature and the installation height

Short-time rating $P_{shortt.}$ of control transformers – the characteristic variable for the dynamic capacity

The most important selection criterion for control transformers is their short-time rating $P_{shortt.}$

This is required for switching on electromagnetic loads, e. g. contactors with high making current in relation to the holding current. According to EN 61558-2-2 "Special requirements for control transformers" the output voltage with this load should not drop more than 5 % in relation to the rated voltage in order to ensure safe switching.

Depending on their application, control transformers 4AP and 4AU ≤ 16 kVA are optimized for high short-time ratings with comparatively low ratings and thus small size.

Three-Phase Transformers

4AP, 4AU Safety, Isolating, Control and Mains Transformers

General data

Low inrush current – primary-side short-circuit and overload protection with standard circuit breakers

4AP and 4AU three-phase transformers in the performance range ≤ 16 kVA are matched to protective devices that reliably protect the transformers in the event of short-circuits or overloads.

Standard 3RV and 3VF circuit breakers offer optimum protection. This way, the transformers are protected on the primary side against both short-circuits and overload, without the possibility of false tripping on startup. The low inrush current, the short-circuit current and the thermal load capacity on overload are matched to the tripping characteristics of the circuit breakers.

It is also possible to protect the transformers on the secondary side against short-circuits and overloads with circuit breakers or miniature circuit breakers with C characteristics.

Note:

The specified primary-side circuit breakers are for protecting the primary side of transformers in the event of short-circuits and overload on the secondary side. In the event of a possible short-circuit on the feeder lines between the protective device and the primary side of the transformer, the rated short-circuit breaking capacity of the circuit breaker must be taken into account with regard to the maximum possible prospective short-circuit current at the place of installation. For these device assignments, see the tables in the "Technical specifications".

Design

All 4AP and 4AU three-phase transformers are supplied for screw fixing on a mounting plate.

Terminals

The 4AP transformers up to a rated current of 60 A and the 4AU transformers up to a rated current of 43 A in the standard version are supplied with screw terminals.

For higher currents, the transformers are supplied with flat connectors or with threaded bolts.

Enclosure mounting

4AP and 4AU transformers are also available in protective enclosures of the degree of protection IP23 and IP54.

Required specifications for requests and orders for 4AP and 4AU transformers with selectable voltages

Rated power P_n (output division with separate SEC windings, $P_n = P_1 + P_2$, throughput rating = load rating for autotransformers), PRI and SEC voltages, frequency, vector group, degree of protection (power reduction with degrees of protection other than IP00), Order No. stem.

The Order No. stem is added to the Order No. for delivery.

Example:

Three-phase transformer with selectable voltages 16 kVA
PRI 415 V \pm 5 %, SEC 115 V,
frequency 50 Hz ... 60 Hz,
degree of protection IP00,
shield winding,
Order No. stem 4AU39 3.

4AP and 4AU autotransformers: determine the type rating $P_{n \text{ req.}}$

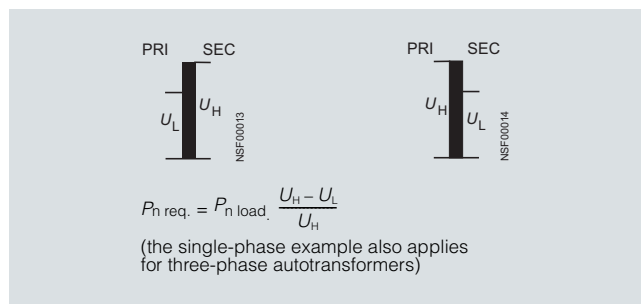

Step-up transformer (left) and step-down transformer (right)

Three-Phase Transformers

4AP, 4AU Safety, Isolating, Control and Mains Transformers

General data

Technical specifications

Transformers	Type	4AP	4AU
• Version		3UI core	3UI core
• Performance range (with IP00)	kVA	0.16 ... 5	> 5 ... 16
• Approvals			
Voltage range	V	≤ 690	
• Approvals for USA, Canada	V	≤ 600	
Rated frequency	Hz	50 ... 60	
Thermal class		B	H
• Acc. to UL/CSA		Class 130	Class 180
Ambient conditions	Protection against harmful ambient conditions: complete impregnation in polyester resin Climate-proof for installation in rooms with an external climate to DIN 50010		
Rated ambient temperature			
• At rated power	°C	40	55
• Maximum value (after power reduction depending on load characteristics, see "Design")	°C	80	
• Minimum value	°C	-25	
Relative air humidity			
• Mean value up to	%	80	
• Maximum value for 30 days/year	%	95	
• At 40 °C occasionally	%	100	
Protection class		I	
Degree of protection			
• Without enclosure		IP00	
• With protective enclosure (acc. to "Selection and ordering data", see Catalog LV 1)		IP23 or IP54	
• Version		IP23, IP54: sheet-steel enclosure coated with epoxy resin, color gray RAL 7032	
Installation height		Up to 1000 m above sea level (above this, power reduction is necessary)	
Protective devices			
• External		The transformers can be protected against short-circuits and overload on the primary and secondary side with circuit breakers. For reliable protection against short-circuits, overload and touch, the cables between the output terminals of the transformer and the load must have a negligible line impedance. For more details see DIN VDE 0100 (Erection of low-voltage systems) Part 410, Part 520 (particularly section 525) and Part 600 (similar to IEC 60364-4-41, -5-52 and -6). Assigned protective devices (see "Primary-side short-circuit and overload protection with motor starter protectors")	
Connection methods		The permissible conductor cross-sections are assigned to the specified terminal types.	
• Terminal arrangement (see "Schematics")		Refer to DIN VDE 0298-4 and EN 60204 for the permissible conductor cross-sections for the specified current according to the installation type. The terminals used are finger-safe according to EN 50274.	
• For terminal versions and connectable cross-sections (see "Project planning aids")		Other terminal sizes than standard versions on request.	
Mounting position		The permissible mounting position for each version is shown in the "Project planning aids".	

Further technical specifications can be found on the Internet at <http://www.siemens.com/sirius-supplying>.

Three-Phase Transformers

4AP, 4AU Safety, Isolating, Control and Mains Transformers

General data

Rated outputs at different ambient temperatures

- With electrically isolated windings
- Degree of protection IP00
- According to EN 61558, **CLASS**

Transformers	Rated power P_n	Permissible transformer load depending on the ambient temperature t_a of							
		60 °C	55 °C	50 °C	45 °C	40 °C	35 °C	30 °C	25 °C
Type	kVA	kVA	kVA	kVA	kVA	kVA	kVA	kVA	kVA
4AP transformers									
4AP17 4	0.16	0.134	0.141	0.147	0.154	0.160	0.166	0.173	0.178
4AP18 4	0.25	0.210	0.220	0.230	0.240	0.250	0.260	0.270	0.278
4AP19 4	0.4	0.336	0.352	0.368	0.384	0.400	0.416	0.432	0.444
4AP20 4	0.63	0.529	0.554	0.580	0.605	0.630	0.655	0.680	0.699
4AP21 4	1	0.840	0.880	0.920	0.960	1	1.04	1.08	1.11
4AP25 4	1.6	1.34	1.41	1.47	1.54	1.60	1.66	1.73	1.78
4AP27 4	2.5	2.10	2.20	2.30	2.40	2.50	2.60	2.70	2.78
4AP30 4	4	3.36	3.52	3.68	3.84	4	4.16	4.32	4.44
4AP30 5	5	4.20	4.40	4.60	4.80	5.50	5.20	5.40	5.55
4AU transformers									
4AU30 3	6.3	6.11	6.30	6.49	6.68	6.93	7.12	7.31	7.50
4AU36 1	8	7.76	8	8.24	8.48	8.80	9.04	9.28	9.52
4AU36 3	10	9.70	10	10.3	10.6	11	11.3	11.6	11.9
4AU39 1	12.5	12.1	12.5	12.9	13.3	13.8	14.1	14.5	14.9
4AU39 3	16	15.5	16	16.5	17	17.6	18.1	18.6	19

Operation characteristics

- According to EN 61558-2-6, EN 61558-2-4, EN 61558-2-1

Transformers	Rated power P_n	Core size	Voltage rise in no-load operation (operating temperature) u_A approx.	Voltage drop on rated load ¹⁾ u_R approx.	Short-circuit voltage ¹⁾ u_Z approx.	Degree of efficiency η approx.
Type	kVA		%	%	%	%
4AP transformers: $t_a = 40$ °C/B						
4AP17 4	0.16	3UI 60/30	13.3	10.1	10.1	85
4AP18 4	0.25	3UI 75/25	11.7	8.9	9	87
4AP19 4	0.4	3UI 75/40	11.8	8.5	8.5	87
4AP20 4	0.63	3UI 90/30	9.3	6.8	6.8	89
4AP21 4	1	3UI 90/50	6.4	4.8	4.8	92
4AP25 4	1.6	3UI 114/62	4.9	3.6	3.6	93
4AP27 4	2.5	3UI 132/70	4.5	3.4	3.4	94
4AP30 4	4	3UI 150/75	3.5	2.6	2.7	95
4AP30 5	5	3UI 150/75	2.8	2.1	2.2	96
4AU transformers: $t_a = 55$ °C/H						
4AU30 3	6.3	3UI 150/75	3.8	2.6	2.6	96
4AU36 1	8	3UI 180/75	5.1	3.6	3.6	94
4AU36 3	10	3UI 180/75	4.1	2.9	3	95
4AU39 1	12.5	3UI 210/70	4.1	2.9	3.1	95
4AU39 3	16	3UI 210/70	3.2	2.3	2.8	96

Higher ratings and other conditions on request.

Calculation of power loss P_V

$$P_V = \frac{P_n (100 - \eta)}{\eta} \text{ [kW]}$$

¹⁾ Winding reference temperature: 20 °C.

Three-Phase Transformers

4AP, 4AU Safety, Isolating, Control and Mains Transformers

General data

Primary-side short-circuit and overload protection with motor starter protectors

Trans- formers	Rated power P_n kVA	Motor starter protector version: Motor protection Type	Rated input voltage U_{1N} in V																	
			520	500	480	460	440	420	400	380	360	300	288	277	265	254	242	230	220	208
4AP transformers																				
4AP17 4	0.16	3RV10 11-□□□10 Set value in A	0DA	0DA	0EA	0EA	0EA	0EA	0EA	0EA	0FA	0GA	0GA	0GA	0HA	0HA	0HA	0HA	0HA	0HA
4AP18 4	0.25	3RV10 11-□□□10 Set value in A	0FA	0FA	0FA	0FA	0FA	0GA	0GA	0GA	0HA	0JA	0JA	0JA	0KA	0KA	0KA	0KA	0KA	0KA
4AP19 4	0.4	3RV10 11-□□□10 Set value in A	0HA	0HA	0JA	0JA	0JA	0JA	0JA	0JA	0KA	1AA	1AA	1AA	1AA	1BA	1BA	1BA	1BA	1BA
4AP20 4	0.63	3RV10 11-□□□10 Set value in A	0KA	0KA	1AA	1AA	1AA	1AA	1AA	1AA	1BA	1CA	1CA	1CA	1CA	1CA	1DA	1DA	1DA	1DA
4AP21 4	1	3RV10 11-□□□10 Set value in A	1BA	1BA	1CA	1CA	1CA	1CA	1CA	1CA	1DA	1EA	1EA	1EA	1EA	1EA	1EA	1EA	1EA	1FA
4AP25 4	1.6	3RV10 11-□□□10 Set value in A	1DA	1DA	1EA	1EA	1EA	1EA	1EA	1FA	1FA	1GA	1GA	1GA	1GA	1HA	1HA	1HA	1HA	1HA
4AP27 4	2.5	3RV10 11-□□□10 Set value in A	1FA	1FA	1FA	1GA	1GA	1GA	1GA	1HA	1HA	1JA	1JA	1JA	1JA	1JA	1JA	1JA	1KA	1KA
4AP30 4	4	3RV10 11-□□□10 3RV10 21-□□□10 Set value in A	1HA	1HA	1HA	1JA	1JA	1JA	1JA	1JA	1KA	--	--	--	--	--	--	--	--	--
4AP30 5	5	3RV10 11-□□□10 3RV10 21-□□□10 Set value in A	1JA	1JA	1JA	1KA	1KA	1KA	--	--	--	--	--	--	--	--	--	--	--	--
4AU transformers																				
4AU30 3	6.3	3RV10 11-□□□10 3RV10 21-□□□10 Set value in A	1KA	1KA	1KA	1KA	--	--	--	--	--	--	--	--	--	--	--	--	--	--
4AU36 1	8	3RV10 21-□□□10 3RV10 31-□□□10 Set value in A	4AA	4AA	4AA	4AA	4AA	4BA	4BA	4BA	4BA	4CA	4CA	4CA	4DA	4DA	4DA	--	--	--
4AU36 3	10	3RV10 21-□□□10 3RV10 31-□□□10 Set value in A	4BA	4BA	4BA	4BA	4CA	4CA	4CA	4CA	4CA	4DA	4DA	--	--	--	--	--	--	--
4AU39 1	12.5	3RV10 21-□□□10 3RV10 31-□□□10 Set value in A	4CA	4CA	4CA	4CA	4DA	4DA	4DA	4DA	4DA	--	--	--	--	--	--	--	--	--
4AU39 3	16	3RV10 21-□□□10 3RV10 31-□□□10 Set value in A	4DA	4DA	4DA	4DA	--	--	--	--	--	--	--	--	--	--	--	--	--	--

Three-Phase Transformers

4AP, 4AU Safety, Isolating, Control and Mains Transformers

General data

Secondary-side short-circuit and overload protection with motor starter protector or miniature circuit breaker¹⁾

Transformers	Rated power P_n	Motor starter protectors		
		Version: Motor protection Type	Rated output voltage U_{2N} in V	
Type	kVA		400	230
4AP transformers				
4AP17 4	0.16	3RV10 11-□□□10 Set value in A	0DA 0.27	0FA 0.5
4AP18 4	0.25	3RV10 11-□□□10 Set value in A	0FA 0.42	0HA 0.75
4AP19 4	0.4	3RV10 11-□□□10 Set value in A	0HA 0.7	0KA 1.2
4AP20 4	0.63	3RV10 11-□□□10 Set value in A	0KA 1.1	1BA 1.9
4AP21 4	1	3RV10 11-□□□10 Set value in A	1BA 1.7	1DA 3
4AP25 4	1.6	3RV10 11-□□□10 Set value in A	1DA 2.7	1FA 5
4AP27 4	2.5	3RV10 11-□□□10 Set value in A	1FA 4.2	1HA 7.5
4AP30 4	4	3RV10 11-□□□10 Set value in A	1HA 6.7	1KA 12
4AP30 5	5	3RV10 11-□□□10 3RV10 21-□□□10 Set value in A	1JA -- 8.5	-- 4AA 15
4AU transformers				
4AU30 3	6.3	3RV10 11-□□□10 3RV10 21-□□□10 Set value in A	1KA -- 11	-- 4BA 19
4AU36 1	8	3RV10 21-□□□10 Set value in A	4AA 14	4DA 24
4AU36 3	10	3RV10 21-□□□10 3RV10 31-□□□10 Set value in A	4BA -- 17	-- 4EA 29
4AU39 1	12.5	3RV10 21-□□□10 3RV10 31-□□□10 Set value in A	4CA -- 21	-- 4FA 37
4AU39 3	16	3RV10 31-□□□10 Set value in A	4EA 27	4HA 47

¹⁾ Miniature circuit breaker on request.

Short-time rating of control transformers $P_{short.}^{1)} = f(p.f.)$ for $U_2 = 0.95 \times U_{2N}$

Transformers	Rated power P_n	Short-time rating $P_{short.}^{1)}$ with p.f. of										Voltage rise in no-load operation (operating temperature) u_A %	Voltage drop on rated load (at 20 °C) u_R %	Short-circuit voltage (at 20 °C) u_Z %	
		0.1	0.2	0.3	0.4	0.5	0.6	0.7	0.8	0.9	1				
Type	kVA	kVA	kVA	kVA	kVA	kVA	kVA	kVA	kVA	kVA	kVA				
4AP transformers															
4AP20 4	0.63	4.5	3.3	2.6	2.1	1.8	1.6	1.4	1.3	1.2	1.1	9.3	6.8	6.8	
4AP21 4	1	9.3	6.5	5	4.1	3.5	3	2.7	2.4	2.2	2.1	6.4	4.8	4.8	
4AP25 4	1.6	21	14	10	8.3	6.9	5.9	5.2	4.7	4.2	3.9	4.9	3.6	3.6	
4AP27 4	2.5	37	24	17	14	11	9.9	8.7	7.8	7	6.5	4.5	3.4	3.4	
4AP30 4	4	60	40	30	24	20	18	16	14	13	12	3.5	2.6	2.7	
4AP30 5	5	53	41	34	29	25	22	20	19	18	17	2.8	2.1	2.2	
4AU transformers															
4AU30 3	6.3	64.5	48.5	39	32.5	28	25	22.5	20.5	19	18.5	3.5	2.6	2.6	
4AU36 1	8	83	58.5	45	37	31.5	27.5	24	22	20	19	5.1	3.6	3.6	
4AU36 3	10	80.5	63	52	44	39	35	31.5	29	27.5	27	4.1	2.9	3	
4AU39 1	12.5	104	80.5	66	56	49	44	39.5	36	34.5	34	4.1	2.9	3.1	
4AU39 3	16	85	74	66	60	55	51.5	48.5	46.5	46	51	3.2	2.3	2.8	

¹⁾ $P_{short.}$ applies to up to 300 contactor operations per hour.

Three-Phase Transformers

4AP, 4AU Safety, Isolating, Control and Mains Transformers

General data

Schematics

In two-voltage version

Circuit diagrams and terminal assignments	Rated input voltage U_{1N}	Rated output voltage U_{2N}	Connections and links		
			Rated voltage	Terminals	Links ¹⁾
<p>Vector group IIIiii0</p> <p>NSF00036</p> <p>4AP17 to 4AP30</p> <p>2U1 2U2 2V1 2V2 2W1 2W2 NSF00037</p> <p>1U1 1U3 1U2 1V1 1V3 1V2 1W1 1W3 1W2</p> <p>4AU30 to 4AU39</p> <p>1U1 1U3 1U2 1V1 1V3 1V2 1W1 1W3 1W2 NSF00038a</p> <p>2U1 2U2 2V1 2V2 2W1 2W2</p>	Y 500-400 / Δ 289-230	Y 400/ Δ 230	Primary		
			500 400 289 230	1U1-1V1-1W1	1U2-1V2-1W2 1U3-1V3-1W3 1U1-1W2, 1V1-1U2, 1W1-1V2 1U1-1W3, 1V1-1U3, 1W1-1V3
			Secondary		
			400 230	2U1-2V1-2W1 2U1-2V1-2W1	2U2-2V2-2W2 2U1-2W2, 2V1-2U2, 2W1-2V2

Multi-voltage version

Circuit diagrams and terminal assignments	Rated input voltage U_{1N}	Rated output voltage U_{2N}	Connections and links		
			Rated voltage	Terminals	Links ¹⁾
<p>Vector group IIIiii0</p> <p>NSF00039a</p> <p>4AP20 to 4AP30</p> <p>2U1 2U2 2V1 2V2 2W1 2W2 NSF00041</p> <p>1U1 1U3 1U4 1U5 1U6 1U2 1V1 1V3 1V4 1V5 1V6 1V2 1W1 1W3 1W4 1W5 1W6 1W2</p> <p>4AU30 to 4AU39</p> <p>1U1 1U3 1U4 1U5 1U6 1U2 1V1 1V3 1V4 1V5 1V6 1V2 1W1 1W3 1W4 1W5 1W6 1W2 NSF00042a</p> <p>2U1 2U2 2V1 2V2 2W1 2W2</p>	Y 520-500- 480-460- 440-420- 400-380- 360/ Δ 300-289- 277-266- 254-240- 230-220- 208	Y 400/ Δ 230	Primary		
			520 500 480 460 440 420 400 380 360	1U1-1V1-1W1 1U1-1V1-1W1 1U1-1V1-1W1 1U3-1V3-1W3 1U3-1V3-1W3 1U3-1V3-1W3 1U4-1V4-1W4 1U4-1V4-1W4 1U4-1V4-1W4	1U2-1V2-1W2 1U6-1V6-1W6 1U5-1V5-1W5 1U2-1V2-1W2 1U6-1V6-1W6 1U5-1V5-1W5 1U2-1V2-1W2 1U6-1V6-1W6 1U5-1V5-1W5 1U2-1V1, 1V2-1W1, 1W2-1U1 1U6-1V1, 1V6-1W1, 1W6-1U1 1U5-1V1, 1V5-1W1, 1W5-1U1 1U2-1V3, 1V2-1W3, 1W2-1U3 1U6-1V3, 1V6-1W3, 1W6-1U3 1U5-1V3, 1V5-1W3, 1W5-1U3 1U2-1V4, 1V2-1W4, 1W2-1U4 1U6-1V4, 1V6-1W4, 1W6-1U4 1U5-1V4, 1V5-1W4, 1W5-1U4
			Secondary		
			300 289 277 266 254 240 230 220 208	1U1-1V1-1W1 1U1-1V1-1W1 1U1-1V1-1W1 1U3-1V3-1W3 1U3-1V3-1W3 1U3-1V3-1W3 1U4-1V4-1W4 1U4-1V4-1W4	2U2-2V2-2W2 2U1-2V1-2W1 2U2-2V1, 2V2-2W1, 2W2-2U1

¹⁾ Y/Δ disconnecting links are not included in the scope of supply.

Three-Phase Transformers

4BU Power Transformers

General data

Overview

4BU.. transformers

With the right transformer, the right voltage will be available at any conditions.

Our transformers are the right choice for each application: They work reliably, safely and worldwide under a wide range of different conditions.

4BU three-phase power transformers

- Are available as matching transformers with one input/output voltage according to DIN VDE 0532-6
- And can be configured as matching, auto- or converter transformers according to DIN VDE 0532-6 with selectable input and output voltages.

Our transformers provide optimal protection through high permissible ambient temperatures of up to 40 °C or 55 °C.

Design

Standards

DIN VDE 0532-6

Rated power P_n at high ambient temperature – the characteristic for thermal load capacity

Reference conditions under which the transformers have the rated power P_n stated in the selection tables:

- Uninterrupted duty P_n
- Frequency AC 50 Hz ... 60 Hz
- Degree of protection IP00
- Installation height up to 1000 m above sea level and
- Ambient temperature t_a , type-dependent 40 °C or 55 °C.

Other installation and operating conditions than this will affect the permissible permanent load capacity. In case of the 4BU transformers, for example, with a low ambient temperature of 40 °C instead of 55 °C, an increase in load of 8 % is possible (see "Load Characteristics").

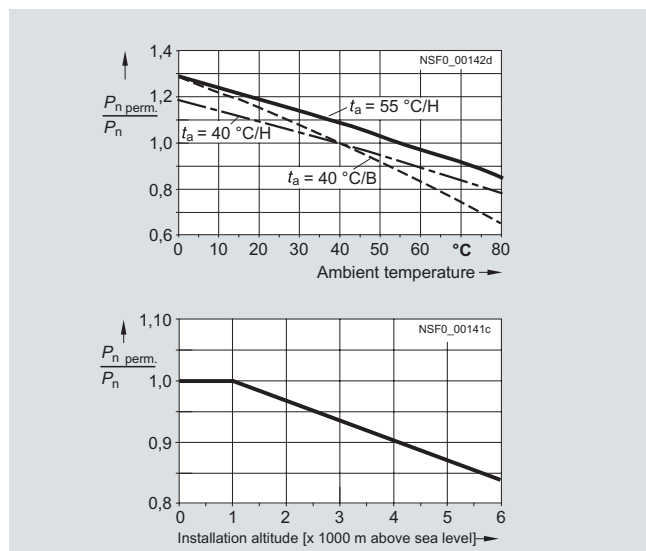

Load characteristics: permissible transformer permanent load in relation to the ambient temperature and the installation height

Design

All 4BU three-phase power transformers are supplied for screw fixing on a mounting plate.

Terminals

The 4BU transformers are supplied for rated currents up to 81 A in the standard version with screw terminals.

For higher currents, the transformers are supplied with flat connectors or with threaded bolts.

Enclosure mounting

4BU transformers are also available in protective enclosures with degree of protection IP20 and IP23.

Required specifications for requests and orders for 4BU transformers with selectable voltages

Rated power P_n (output division with separate SEC windings, $P_n = P_1 + P_2$, throughput rating = load rating for autotransformers), PRI and SEC voltages, frequency, vector group, degree of protection (power reduction with degrees of protection other than IP00), Order No. stem.

The Order No. stem is added to the Order No. for delivery.

Example:

Three-phase power transformer 180 kVA
 PRI 415 V \pm 5 %, SEC 115 V,
 frequency 50 Hz ... 60 Hz,
 degree of protection IP00, shield winding,
 Order No. stem 4BU60 32 (without UL), 4BU60 33 (with **cFLus**)

4BU autotransformers: determine the type rating P_n req.

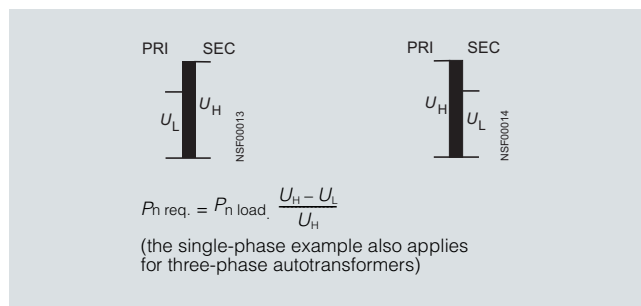

Step-up transformer (left) and step-down transformer (right)

Thermistor transformer protection for 4BU power transformers

The windings of the power transformers can be protected from impermissible overheating by means of thermistor transformer protection. PTC thermistors are used which are wound into each shank of the transformer and connected in series. The rated response temperature is slightly above the limit temperature for uninterrupted duty.

Possible versions:

- Warning
- Disconnection
- Warning and disconnection

The connections for the temperature sensor are routed to terminals, two terminals each for warning and disconnection.

The 3RN tripping units are not included in the transformer scope of supply, for the relevant selection and ordering data see Catalog LV 1, Chapter 7 "Monitoring and Control Devices" → "Monitoring Relays" → "Thermistor Motor Protection".

Three-Phase Transformers

4BU Power Transformers

General data

Technical specifications

Transformers	Type	4BU
• Version		3UI core
• Performance range (with IP00)	kVA	> 16 ... 400 (up to 2000 kVA on request)
• Approvals		cULus optional
Voltage range	V	≤ 1000 (up to 3.6 kV on request)
• Approvals for USA, Canada	V	≤ 600
Rated frequency	Hz	50 ... 60
Thermal class		H
• Acc. to UL/CSA		Class 180
Ambient conditions	Protection against harmful ambient conditions: complete impregnation in polyester resin Climate-proof for installation in rooms with an external climate to DIN 50010	
Rated ambient temperature		
• At rated power	°C	40 and optionally 55
• Maximum value (after power reduction depending on load characteristics, see "Design")	°C	80
• Minimum value	°C	-25
Relative air humidity		
• Mean value up to	%	80
• Maximum value for 30 days/year	%	95
• At 40 °C occasionally	%	100
Protection class		I
Degree of protection		
• Without protective enclosure		IP00
• With protective enclosure (acc. to "Selection and ordering data", see Catalog LV 1)		IP20 or IP23
• Version		IP20, IP23: sheet-steel enclosure coated with epoxy resin, color gray RAL 7032
Installation height		Up to 1000 m above sea level (above this, power reduction is necessary)
Protective devices		
• Internal		Can be designed with thermistor transformer protection for warning or disconnection or warning and disconnection, see "Design"
• External		The transformers can be protected against short-circuits and overload on the primary or secondary side with circuit breakers. For reliable protection against short-circuits and touch, the cables between the output terminals of the transformer and the load must have a negligible line impedance. For more details see DIN VDE 0100 (Erection of low-voltage systems) Part 410, Part 520 (particularly section 525) and part 600. On request
Connection methods		The permissible conductor cross-sections are assigned to the specified terminal types.
• Terminal arrangement		Refer to DIN VDE 0298-4 and EN 60204 for the permissible conductor cross-sections for the specified current according to the installation type. The terminals used are finger-safe according to EN 50274.
• For terminal versions and connectable cross-sections (see "Project planning aids")		Other terminal sizes than standard versions on request.
Mounting position		The permissible mounting position for each version is shown in the "Project planning aids".

Selecting the fuses:

Short-circuit protection on the primary or secondary side using DIAZED or LV HRC fuses with characteristic gL/gG for 4BU43 to 4BU65 power transformers in the performance range from 18 kVA to 400 kVA.

Determining the fuse size:

$$\text{Rated current } I_n = \frac{\text{Rated power } P_n}{\text{Rated voltage } U_{1N}}$$

Minimum fuse current = Rated current x 1.2
Maximum fuse current = Rated current x 1.5

Example:

4BU56 power transformer,
degree of protection IP00,
rated power $P_n = 100 \text{ kVA}$,
rated voltage $U_{1N} = 400 \text{ V}$,
rated current $I_n = ?$

$$I_n = \frac{P_n}{U_{1N}} = \frac{100000 \text{ VA}}{400 \text{ V}} = 250 \text{ A}$$

Minimum fuse current = $144.3 \text{ A} \times 1.2 = 173 \text{ A}$
Maximum fuse current = $144.3 \text{ A} \times 1.5 = 216 \text{ A}$

Selected fuse size: 200 A

Further technical specifications can be found on the Internet at <http://www.siemens.com/sirius-supplying>.

Three-Phase Transformers

4BU Power Transformers

General data

Operation characteristics

- According to DIN VDE 0532-6
- $t_a = 40\text{ °C/H}$

Transformers	Rated power P_n 50 Hz ... 60 Hz 1000 m above sea level Degree of protection IP00 kVA	Core size	Voltage rise in no-load operation (operating temperature)	Voltage drop on rated load ¹⁾	Short-circuit voltage ¹⁾	Degree of efficiency
			u_A approx. %	u_R approx. %	u_Z approx. %	η approx. %
			4BU...2/4BU...3 ²⁾	4BU...2/4BU...3 ²⁾	4BU...2/4BU...3 ²⁾	4BU...2/4BU...3 ²⁾
4BU43 3.	18	3UI 230/80	4.2/4.0	3.9/3.7	4.0/3.8	95
4BU43 4.	20	3UI 230/80	3.8/3.6	3.5/3.4	3.7/3.5	96
4BU43 5.	22.5	3UI 230/80	3.4/3.2	3.1/3.0	3.4	96
4BU45 3.	25	3UI 230/107	3.3/3.1	3.0/2.9	3.1/3.0	96
4BU45 4.	28	3UI 230/107	2.9/2.8	2.7/2.6	2.9/2.8	96
4BU47 3.	31.5	3UI 230/137	2.7/2.6	2.5/2.4	2.6/2.5	96/97
4BU47 4.	35.5	3UI 230/137	2.4/2.3	2.2	2.4/2.3	97
4BU47 5.	40	3UI 230/137	2.1/2.0	2.0/1.9	2.3/2.2	97
4BU52 3.	45	3UIS 220/120	3.4/3.2	3.1/3.0	3.9/3.8	96
4BU53 3.	50	3UIS 220/135	3.1/2.9	2.8/2.7	3.5	96/97
4BU53 4.	56	3UIS 220/135	2.7/2.6	2.5/2.4	3.6/3.5	97
4BU54 3.	63	3UIS 305/125	4.0/3.9	3.7/3.6	4.3/4.2	95/96
4BU54 4.	71	3UIS 305/125	3.6/3.4	3.3/3.2	4.2	96
4BU55 3.	80	3UIS 305/140	3.3/3.1	3.0/2.9	3.9	96
4BU56 3.	91	3UIS 305/160	3.0/2.9	2.8/2.7	3.6	96/97
4BU56 4.	100	3UIS 305/160	2.7/2.6	2.5	3.7	97
4BU58 3.	112	3UIS 395/150	4.4/4.2	4.0/3.9	4.9/4.8	95
4BU58 4.	125	3UIS 395/150	3.9/3.8	3.6/3.5	4.9/4.8	96
4BU58 5.	140	3UIS 395/150	3.5/3.4	3.2/3.1	5.1/5.0	96
4BU59 3.	160	3UIS 395/170	3.2/3.1	3.0/2.9	4.7	96
4BU60 3.	180	3UIS 395/195	3.0/2.9	2.8/2.7	4.3/4.2	97
4BU62 3.	200	3UIS 455/175	2.8/2.6	2.6/2.5	3.8/3.7	97
4BU62 4.	225	3UIS 455/175	2.4/2.3	2.3/2.2	4.0	97
4BU62 5.	250	3UIS 455/175	2.2/2.1	2.1/2.0	4.5	97
4BU63 3.	280	3UIS 455/200	2.1/2.0	1.9	4.0/4.5	97/98
4BU63 4.	315	3UIS 455/200	1.8/1.7	1.7	4.7	98
4BU64 3.	355	3UIS 455/230	1.7/1.6	1.6/1.5	4.2/4.3	98
4BU65 3.	400	3UIS 455/260	1.6/1.5	1.5/1.4	4.0/4.3	98

Higher ratings and other conditions on request.

Calculation of power loss P_V

$$P_V = \frac{P_n (100 - \eta)}{\eta} \text{ [kW]}$$

1) Winding reference temperature: 115 °C.

2) 4BU...2 without **certus** approval; 4BU...3 with **certus** approval.

Three-Phase Transformers

4BU Power Transformers

General data

Schematics

Circuit diagrams and terminal assignments	Rated input voltage U_{1N} V	Rated output voltage U_{2N} V	Connections and links																			
			Rated voltage V	Terminals	Links																	
Vector group Dyn5																						
<p>Up to 81 A: terminals <table border="1"> <tr> <td>1U1</td><td>1V1</td><td>1W1</td><td>2U2</td><td>2V2</td><td>2W2</td><td>2N</td> </tr> </table> NSF0_00201</p> <p>> 81 A flat connectors, see "Project planning aids".</p>	1U1	1V1	1W1	2U2	2V2	2W2	2N	Δ 480 Δ 440 Δ 400	Y 400 Y 208	Primary												
	1U1	1V1	1W1	2U2	2V2	2W2	2N															
480	1U1-1V1-1W1	--																				
			440	1U1-1V1-1W1	--																	
			400	1U1-1V1-1W1	--																	
			Secondary																			
			400	2U2-2V2-2W2	--																	
			208	2U2-2V2-2W2	--																	
Vector group Dyn5 ±5 %																						
<p>Up to 81 A: terminals <table border="1"> <tr> <td>1U3</td><td>1U4</td><td>1U2</td><td>1V1</td><td>1V3</td><td>1V4</td><td>1V2</td><td>1W1</td><td>1W3</td><td>1W4</td><td>1W2</td><td>1U1</td><td>1U1</td><td>2U2</td><td>2V2</td><td>2W2</td><td>2N</td> </tr> </table> NSF0_00203</p> <p>> 81 A flat connectors, see "Project planning aids".</p>	1U3	1U4	1U2	1V1	1V3	1V4	1V2	1W1	1W3	1W4	1W2	1U1	1U1	2U2	2V2	2W2	2N	Δ 504-480-456 Δ 462-440-418 Δ 420-400-380	Y 400 Y 208	Primary		
	1U3	1U4	1U2	1V1	1V3	1V4	1V2	1W1	1W3	1W4	1W2	1U1	1U1	2U2	2V2	2W2	2N					
504	1U1-1V1-1W1	1U2-1V1; 1V2-1W1; 1W2-1U1																				
	480		1U4-1V1; 1V4-1W1; 1W4-1U1																			
	456		1U3-1V1; 1V3-1W1; 1W3-1U1																			
	462	1U1-1V1-1W1	1U2-1V1; 1V2-1W1; 1W2-1U1																			
	440		1U4-1V1; 1V4-1W1; 1W4-1U1																			
	418		1U3-1V1; 1V3-1W1; 1W3-1U1																			
	420	1U1-1V1-1W1	1U2-1V1; 1V2-1W1; 1W2-1U1																			
	400		1U4-1V1; 1V4-1W1; 1W4-1U1																			
	380		1U3-1V1; 1V3-1W1; 1W3-1U1																			
			Secondary																			
			400	2U2-2V2-2W2	--																	
			208	2U2-2V2-2W2	--																	
Vector group Yyn0																						
<p>Up to 81 A: terminals <table border="1"> <tr> <td>1U1</td><td>1V1</td><td>1W1</td><td>2U1</td><td>2V1</td><td>2W1</td><td>2N</td> </tr> </table> NSF0_00205</p> <p>> 81 A flat connectors, see "Project planning aids".</p>	1U1	1V1	1W1	2U1	2V1	2W1	2N	Y 480 Y 440 Y 400	Y 400 Y 208	Primary												
	1U1	1V1	1W1	2U1	2V1	2W1	2N															
480	1U1-1V1-1W1	--																				
	440	1U1-1V1-1W1	--																			
	400	1U1-1V1-1W1	--																			
			Secondary																			
			400	2U1-2V1-2W1	--																	
			208	2U1-2V1-2W1	--																	
Vector group Yyn0 ±5 %																						
<p>Up to 81 A: terminals <table border="1"> <tr> <td>1U1</td><td>1U3</td><td>1U4</td><td>1V1</td><td>1V3</td><td>1V4</td><td>1W1</td><td>1W3</td><td>1W4</td><td>2U1</td><td>2V1</td><td>2W1</td><td>2N</td> </tr> </table> NSF0_00207</p> <p>> 81 A flat connectors, see "Project planning aids".</p>	1U1	1U3	1U4	1V1	1V3	1V4	1W1	1W3	1W4	2U1	2V1	2W1	2N	Y 504-480-456 Y 462-440-418 Y 420-400-380	Y 400 Y 208	Primary						
	1U1	1U3	1U4	1V1	1V3	1V4	1W1	1W3	1W4	2U1	2V1	2W1	2N									
504	1U1-1V1-1W1	--																				
	480	1U3-1V3-1W3	--																			
	456	1U4-1V4-1W4	--																			
	462	1U1-1V1-1W1	--																			
	440	1U3-1V3-1W3	--																			
	418	1U4-1V4-1W4	--																			
	420	1U1-1V1-1W1	--																			
	400	1U3-1V3-1W3	--																			
	380	1U4-1V4-1W4	--																			
			Secondary																			
			400	2U1-2V1-2W1	--																	
			208	2U1-2V1-2W1	--																	

1) Yyn0; according to DIN VDE 0532 single-phase loading is permissible only up to 10 % of the rated current of a phase.

Three-Phase Transformers

4AP, 4AU Autotransformers

For matching purposes
according to EN 61558-2-13

Overview

- Shared input and output windings without electrical isolation
- Enable the voltage matching of electrical loads
- Designed for uninterrupted duty (100 % ON period)
- Vector group YNa0
- 4AP: $t_a = 50\text{ °C}$ (T50/B), 4AU: $t_a = 55\text{ °C}$ (T55/H)
- **RUUS**



4AP (left) and 4AU (right)

Technical specifications

Maximum rated output power P_n at different rated input voltages (degree of protection IP00)

With this version of the 4A...2-8HA20-2XA0 autotransformers, higher ratings than the quoted ratings can be found in the following table depending on the input voltage.

Transformers	Output power P_n at input voltage				
	480 V kVA	460 V kVA	440 V kVA	415 V kVA	380 V kVA
4AP21 42-8HA20-2XA0	5	5.8	6.3	6.8	6.8
4AP25 52-8HA20-2XA0	9.1	10.5	11.4	12.3	12.3
4AP27 42-8HA20-2XA0	12.5	14.4	15.6	16.9	15.8
4AP27 52-8HA20-2XA0	16	18.4	20	21.6	20.3
4AP30 52-8HA20-2XA0	22.5	25.9	28.1	30.4	30.4
4AU30 32-8HA20-2XA0	31.5	36.2	39.4	42.5	42.5
4AU36 32-8HA20-2XA0	50	57.5	62.5	59.5	54.5

Primary-side short-circuit and overload protection with motor starter protectors

The otherwise customary consideration of the inrush current plays a subordinate role for an autotransformer. For this reason, it is possible to proceed as follows when selecting the motor starter protectors:

$$I_{1N} = \frac{P_{n \text{ load}}}{U_{1N} \times \sqrt{3}}$$

The motor starter protector resulting for this PRI current I_{1N} can be selected.

Example:

Type 4AP27
Connection PRI $U_{1N} = 480\text{ V}$

$$I_{1N} = \frac{15000\text{ VA}}{480\text{ V} \times \sqrt{3}} \times 1.1 = 19.9\text{ A}$$

Motor starter protector:
3RV10 21-4CA10
Set value 20 A

For other motor starter protectors see Catalog LV 1, Chapter 5 "Protection Equipment".

Schematics

Circuit diagrams and terminal assignments

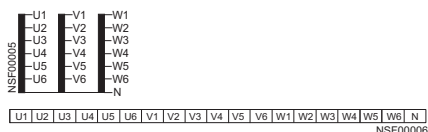

Rated voltage U_N for type

4A□□□ □2-8HA20-2X.0

V
480
460
440
415
400
380

4A□□□ □2-8JT10-2X.0

V
480
460
440
415
400 (380)¹⁾
230 (220)¹⁾

Connection

U1-V1-W1
U2-V2-W2
U3-V3-W3
U4-V4-W4
U5-V5-W5
U6-V6-W6

¹⁾ Operating with 3 AC 380 V at the input terminals results in an output voltage of 3 AC 220 V.

Three-Phase Transformers

4FL Voltage Regulators

4FL voltage regulators, transformer type

Overview



4FL

- According to DIN VDE 0552
- Degree of protection IP21
- $t_a = 40\text{ °C/E}$

Design

The transformer-type voltage regulator supplies electrical loads with a constant voltage despite mains variations.

The advantage of a voltage regulator with a variable-ratio transformer is proportional changing of the sinewave, i. e. the voltage regulator is characterized in that the rms value, mean value and the peak value are held at constant ratios.

A perfect rms value is required, for example, by loads for which the loading is determined by the thermal limits. Strongly capacitive loads in DC units respond to the mean value. A slightly capacitive load is, however, influenced by the peak value. These factors are, however, only guaranteed for sinusoidal AC voltages and this can only be achieved easily by means of a variable-ratio transformer.

Voltage regulators stabilize the mains voltage U_1 regardless of the frequency and power factor to the rated value of output voltage U_{2N} within the set control accuracy ($\pm 1\%$ of U_{2N}). The correcting time from the upper or lower limit to the rated value is between 1.5 s and 2.5 s. The curve shape of the supplied voltage is not changed.

The output voltage U_2 is compared in the electronic step controller with a set reference voltage. In the event of a deviation in voltage greater than the set response value, the electronic step controller compensates the deviation with an accuracy of $\pm 1\%$ using a servo motor and adjustable moving contact on the variable-ratio transformer.

Transformer-type voltage regulators:

- Are electrically connected to the network
- Can be overloaded temporarily (see characteristic curve)
- Can be installed in a sheet-steel enclosure to IP21 complete with any additional components
- Have a degree of efficiency of between 95 % and 98 %
- Are not maintenance-free
- For the values for control range and control deviation, see "Selection and ordering data" in Catalog LV 1.
- For symmetrical mains voltage: The voltage deviation is only monitored on one conductor and set for all three conductors.

- For asymmetrical mains voltage: the voltage deviation is monitored on each conductor and set individually for each conductor.
- The neutral conductor 1N must be connected. If no neutral conductor is present on the mains side, a neutral grounding transformer is required (on request).

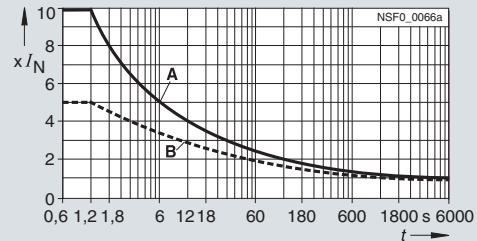

Reference temperature:

- Curve A: winding temperature = ambient temperature
- Curve B: winding temperature = operating temperature

Overload capability (guide values)

Ambient conditions

4FL transformer-type voltage regulators are climate proof for installation in rooms with an internal climate according to DIN 50010.

Limit values:

- Ambient temperature at
 - Rated power $+40\text{ °C}$,
 - Minimum value -25 °C .
- Relative air humidity
 - At 40 °C up to 85 %,
 - Annual average up to 65 %
 - Condensation not permitted

Short-circuit and overload protection

Transformer-type voltage regulators must be protected with gL/gG fuses on the primary side against damage caused by short-circuits. The fuse rated current must be determined according to the highest primary current (present with the lowest input voltage). Overload and short-circuit protective devices according to the rated load current must be provided on the output side. An overload relay is integrated in the control circuit, the trip contacts (break or make) must be connected on a switch that automatically disconnects the transformer voltage regulator from the network in the event of a fault.

Three-Phase Transformers

Project planning aids

Dimensional drawings

4AP, 4AU safety, isolating, control and mains transformers ≤ 16 kVA

4AP safety, isolating, control and mains transformers and 4AP safety, isolating, control and mains transformers and autotransformers with selectable voltages ≤ 16 kVA

4AP17 to 4AP25

for any mounting position,
fixing dimensions according to EN 60852-4 and DIN 41308-4

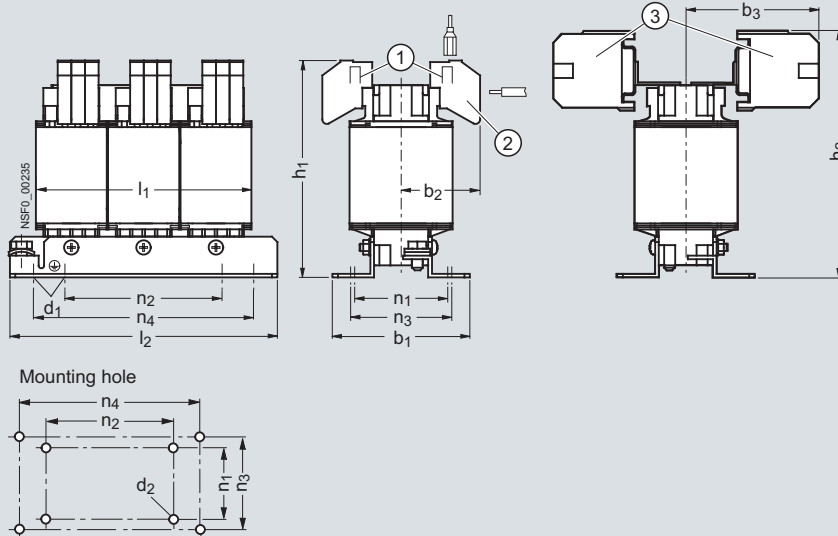

- ① Flat connectors DIN 46244-A 6,3-0,8
- ② Screw terminal
24 A:
solid 0,5 mm² ... 6 mm²,
finely stranded 0,5 mm² ... 4 mm²
- ③ Screw terminal
32 A:
solid 0,75 mm² ... 10 mm²,
finely stranded 1,5 mm² ... 6 mm²
44 A:
solid 1 mm² ... 16 mm²,
finely stranded 1 mm² ... 10 mm²
60 A:
solid 1 mm² ... 16 mm²,
stranded 10 mm² ... 25 mm²,
finely stranded 2,5 mm² ... 16 mm²
> 60 A:
[see flat connectors](#)

Type	Rated power kVA ¹⁾	Design. According to DIN 41302	b_1		b_3	d_1	d_2	h_1		h_2		l_1	l_2	Mounting according to DIN 41308-4		Mounting according to EN 60852-4		Max. number of terminals per side			
				Max.				Max.	Max.	n ₁	n ₂			n ₃	n ₄	24 A	32 A	44 A	60 A		
4AP17	0,16	3UI 60/30	76	58	76	4,8 x 9	M4	130	143	122	148	47	90	58	136	12	12	6	9		
4AP18	0,25	3UI 75/25	73	56	73	5,8 x 11	M5	152	168	156	178	49	113	53	166	15	16	6	12		
4AP19	0,4	3UI 75/40	88	64	81	5,8 x 11	M5	152	168	156	178	64	113	68	166	15	16	6	12		
4AP20	0,63	3UI 90/30	99	59	76	7 x 12	M6	172	193	182	219	56	136	69	201	21	19	12	15		
4AP21	1	3UI 90/50	119	69	86	7 x 12	M6	172	193	182	219	76	136	89	201	21	19	12	15		
4AP25	1,6	3UI 114/62	131	76	92	7 x 12	M6	208	234	229	267	94	176	102	249	27	22	18	19		

¹⁾ The rated power is only applicable to transformers with separate windings (not to autotransformers).

4AP, 4AU safety, isolating, control and mains transformers ≤ 16 kVA (continued)**4AP27 and 4AP30**

for any mounting position

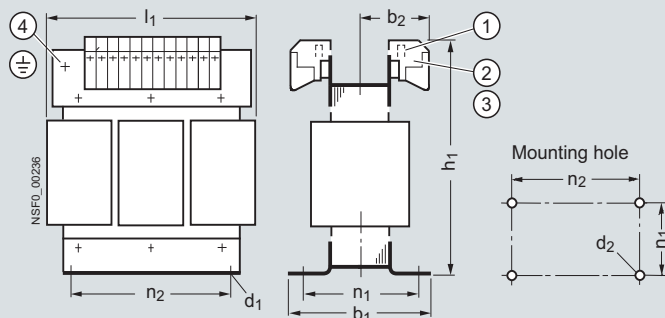

- ① Flat connectors DIN 46244-A 6,3-0,8
- ② Screw terminal
24 A:
solid 0,5 mm² ... 6 mm²,
finely stranded 0,5 mm² ... 4 mm²
- ③ Screw terminal
32 A:
solid 0,75 mm² ... 10 mm²,
finely stranded 1,5 mm² ... 6 mm²
60 A:
solid 1 mm² ... 16 mm²,
stranded 10 mm² ... 25 mm²,
finely stranded 2,5 mm² ... 16 mm²
> 60 A:
[see flat connectors](#)
- ④ Grounding screw M6

Type	Rated power kVA ¹⁾	Designation according to DIN 41302	b ₁	b ₂ Max.	d ₁	d ₂	h ₁ Max.	l ₁	Mounting according to DIN 41308		Max. number of terminals per side		
									n ₁	n ₂	24 A	32 A	60 A
4AP27	2,5	3UI 132/70	133	103	10 x 18	M8	242	264	101	200	27	21	15
4AP30	4; 5	3UI 150/75	148	105	10 x 18	M8	271	300	118	224	27	21	15

¹⁾ The rated power is only applicable to transformers with separate windings (not to autotransformers).

4AU safety, isolating, control and mains transformers and**4AU safety, isolating, control and mains transformers and autotransformers with selectable voltages ≤ 16 kVA****4AU30 to 4AU39**

for any mounting position

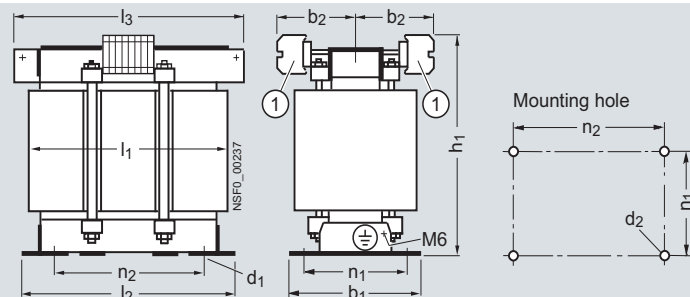

- ① Screw terminal:
18 A:
solid 0,5 mm² ... 6 mm²,
finely stranded 1,5 mm² ... 4 mm²
23 A:
solid 0,75 mm² ... 10 mm²,
finely stranded 1,5 mm² ... 6 mm²
43 A:
solid 1 mm² ... 16 mm²,
stranded 10 mm² ... 25 mm²,
finely stranded 2,5 mm² ... 16 mm²
81 A:
solid or stranded 4 mm² ... 16 mm²
> 81 A:
[see flat-type and threaded pin terminals](#)

Permissible permanent load for 4AU36 and 4AU39 for arrangement on vertical surfaces:

$$0,95 \cdot P_n \text{ at } t_a = 55 \text{ °C}$$

$$P_n \text{ at } t_a = 45 \text{ °C}$$

Type	Rated power kVA ¹⁾	Designation according to DIN 41302	b ₁	b ₂	d ₁	d ₂	h ₁	l ₁	l ₂	l ₃	n ₁	n ₂	Max. number of terminals per side			
													18 A	23 A	43 A	81 A
4AU30	6,3	3UI 150/75	155	129	10 x 18	M8	270	300	264	310	118	224	35	31	23	14
4AU36	8; 10	3UI 180/75	169	134	10 x 18	M8	320	360	314	360	138	264	43	38	28	17
4AU39	12,5; 16	3UI 210/70	174	131	12 x 18	M10	370	420	366	410	141	316	50	45	33	20

¹⁾ The rated power is only applicable to transformers with separate windings (not to autotransformers).

Three-Phase Transformers

Project planning aids

4BU power transformers > 16 kVA

4BU matching transformers and transformers with selectable voltages > 16 kVA

4BU43 to 4BU65

for arrangement on horizontal surfaces

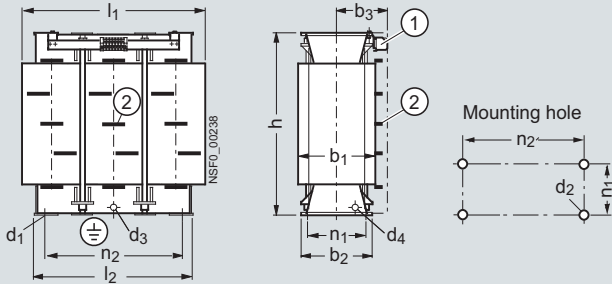

① Screw terminal

Terminal size	Screw terminal for cross-section			Current carr. capac.	
	Solid mm ²	Stranded mm ²	Fin. strand. mm ²	t _a = 40 °C A	t _a = 55 °C A
4	0,5 ... 6	--	1,5 ... 4	24	18
6	2,5 ... 10	--	1,5 ... 6	32	23
16	1,5 ... 16	10 ... 25	4 ... 16	60	43
35	10 ... 16	10 ... 50	10 ... 35	114	81

② Schematic representation of flat connectors

> 81 A/114 A:
see flat-type and threaded pin terminals

Type	Rated power kVA ¹⁾	Type size according to DIN 41302	b ₁	b ₂	b ₃ ± 3 for terminal size				d ₁	d ₂	d ₃	d ₄	h	l ₁	l ₂	n ₁	n ₂	Max. number of terminals for terminal size			
					4	6	16	35										4	6	16	35
4BU43	18; 20; 22,5	3UI 230/80	203	194	153	157	160	170	15	M12	--	M6	422	450	400	155	340	44	36	24	18
4BU45	25; 28	3UI 230/107	230	221	162	166	169	179	15	M12	--	M6	422	450	400	182	340	44	36	24	18
4BU47	31,5; 35,5; 40	3UI 230/137	260	251	182	186	189	199	15	M12	--	M6	422	450	400	212	340	44	36	24	18
4BU52	45	3UIS 220/120	295	225	169	173	176	186	12,5	M10	M12	--	512	420	382	183	316	--	35	23	17
4BU53	50; 56	3UIS 220/135	310	240	176	180	183	193	12,5	M10	M12	--	512	420	382	198	316	--	35	23	17
4BU54	63; 71	3UIS 305/125	265	240	176	180	183	193	15	M12	M12	--	602	630	537	198	465	--	52	35	26
4BU55	80	3UIS 305/140	280	255	184	188	191	201	15	M12	M12	--	602	630	537	213	465	--	52	35	26
4BU56	91; 100	3UIS 305/160	300	275	194	198	201	211	15	M12	M12	--	602	630	537	233	465	--	52	35	26
4BU58	112; 125; 140	3UIS 395/150	315	269	191	195	198	208	15	M12	M12	--	686	855	712	227	630	--	70	45	35
4BU59	160	3UIS 395/170	335	289	201	205	208	218	15	M12	M12	--	686	855	712	247	630	--	70	45	35
4BU60	180	3UIS 395/195	360	314	213	217	220	230	15	M12	M12	--	686	855	712	272	630	--	70	45	35
4BU62	200; 225; 250	3UIS 455/175	360	305	209	213	216	226	21	M12	M12	--	780	975	812	256	720	--	70	45	35
4BU63	280; 315	3UIS 455/200	385	330	221	225	228	238	21	M12	M12	--	780	975	812	281	720	--	70	45	35
4BU64	355	3UIS 455/230	415	360	236	240	243	253	21	M12	M12	--	780	975	812	311	720	--	70	45	35
4BU65	400	3UIS 455/260	445	390	248	252	255	265	21	M12	M12	--	780	975	812	341	720	--	70	45	35

1) The rated power is only applicable to transformers with separate windings (not to autotransformers).

Flat-type and threaded pin terminals

4AP, 4AU, 4BU flat connectors with through-hole

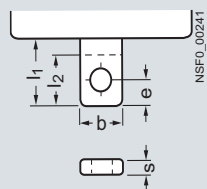

Flat connector on the transformer winding with through-hole for rail or cable lug. Terminal covers for protection against accidental contact, free busbar connections up to 800 A (DIN VDE 0106-100) must be ordered separately.

Type	Terminal size A	b = l ₂	With hole for screw	e	l ₁	s
4AP, 4AU, 4BU	100	16	M6	8	25	2,5
	200	20	M8	10	30	3
	400	25	M10	12,5	35	5
	630	30	M10	15	40	6
	800	30	M12	15	40	8
	1000	40	M12	20	50	8

For terminal covers, see Catalog LV 1, Chapter 3 "Controls – Contactors and Contactor Assemblies, Accessories and Components", Order No. depends on the 3TX6 5.6-3B flat connector.

Threaded bolts on 4AU, 4BU insulating strip

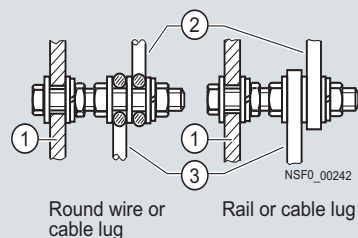

Type	Terminal size A	Threaded bolt	For conductor cross-sections mm ²
4AU, 4BU	200 315 500	M8 M10 M12	≤ 50 ≤ 120 ≤ 300

Protective enclosure with 4AP, 4AU safety, isolating, control and mains transformers ≤ 16 kVA, for degree of protection IP23 and IP54

Mounting positions

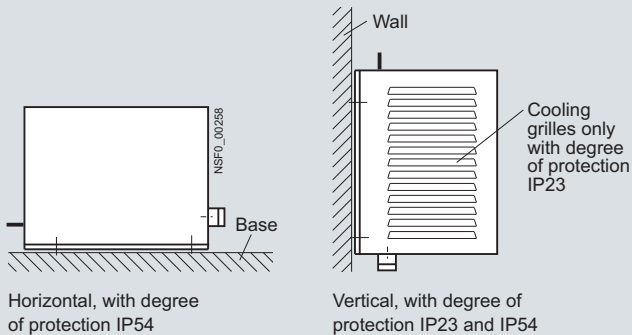

Type	Mounting position	Degree of protection	
		IP23	IP54
4AP, 4AU	horizontal	x	x
	vertical	x	x

x = permissible

Sheet-steel enclosure, epoxy-resin coated, for degree of protection IP23 and IP54



4AP17 to 4AP30, 4AU30 to 4AU39

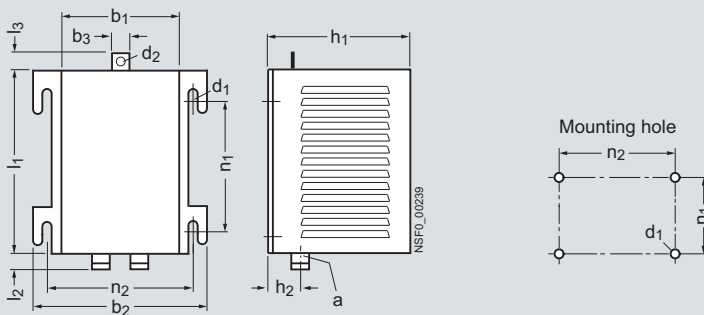

Type	a	b ₁	b ₂	b ₃	d ₁	d ₂	h ₁	h ₂	l ₁	l ₂	l ₃	n ₁	n ₂
4AP17 to 4AP19	2 x M25	187	224	--	5,8	--	230	42	245	35	--	200	212
4AP20 to 4AP30, 4AU30	2 x M32	305	351	--	9	--	330	56	395	45	--	335	333
4AU36, 4AU39	2 x M32	395	460	50	13	35	465	60	555	45	50	480	430

Protective enclosure with dry transformers > 16 kVA, for degree of protection IP20 and IP23

Sheet-steel enclosure, epoxy-resin coated

4BU43 to 4BU65

for arrangement on horizontal surfaces

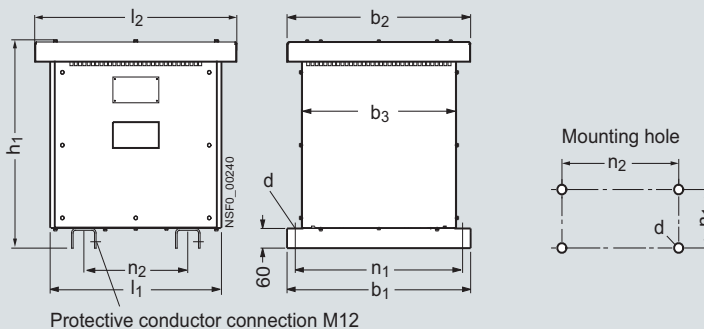

Type	b ₁	b ₂	b ₃	h ₁	d	l ₁	l ₂	n ₁	n ₂
4BU43 to 4BU47	600	600	507	645	15	560	660	570	340
4BU52 and 4BU53	600	600	507	735	15	560	660	570	316
4BU54 to 4BU56	600	600	507	825	15	800	900	570	465
4BU58 to 4BU60	730	730	637	905	19	1120	1220	696	630
4BU62 to 4BU65	900	900	807	1005	19	1120	1220	858	720

Three-Phase Transformers

Project planning aids

4FL voltage regulators

4FL voltage regulators, transformer type

4FL, degree of protection IP21

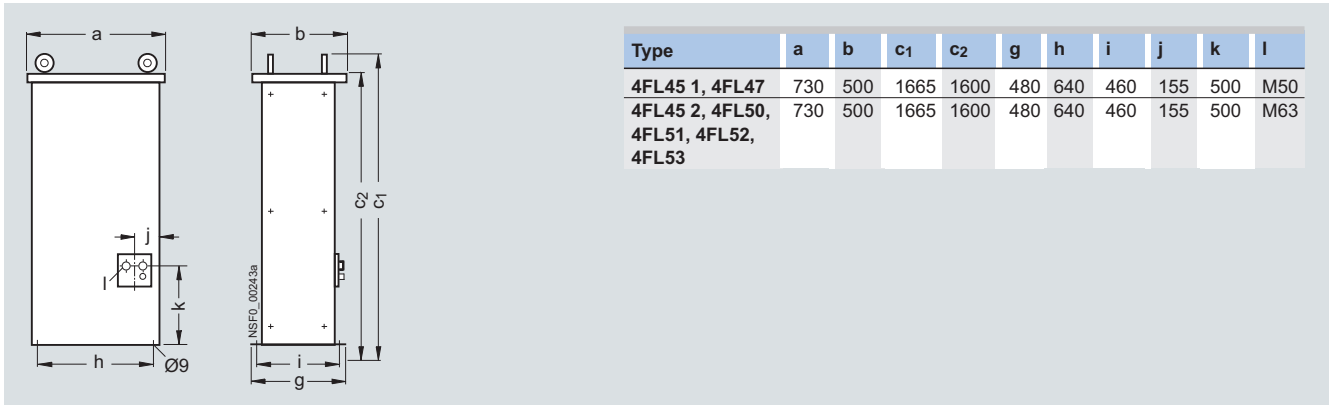

4FL, degree of protection IP21

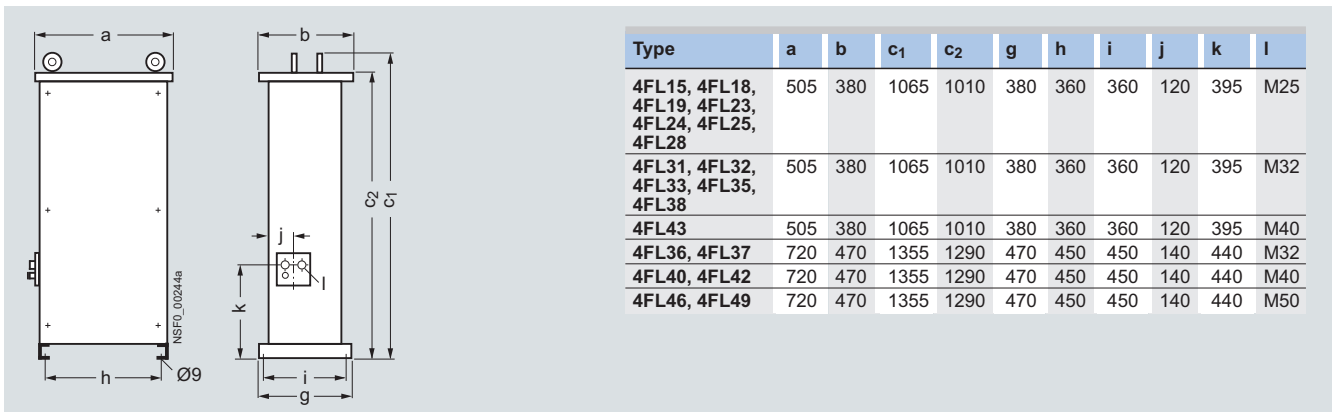

Power Supplies



11/2

Introduction

4AV Non-Stabilized Power Supplies

Filtered for Supply of Electronic Controls

General data

11/3 - Overview

11/3 - Design

11/3 - Function

11/4 - Technical specifications

4AV2, 4AV4 power supplies,
filtered, single-phase

11/6 - Overview

11/6 - Schematics

4AV3, 4AV5 power supplies,
filtered, three-phase

11/7 - Overview

11/7 - Schematics

Unfiltered for Supply of General Loads

4AV98 power supplies,
unfiltered, single-phase

11/8 - Overview

11/8 - Design

11/8 - Schematics

4AV96 power supplies,
unfiltered, three-phase

11/9 - Overview

11/9 - Design

11/9 - Technical specifications

11/9 - Schematics

Project Planning Aids

11/10 - Dimensional drawings

6EP Stabilized Power Supplies

1) SITOP 6EP power supplies

1) See Catalog KT 10.1
"SITOP Power Supplies and
LOGO!Power".

Introduction

Overview

4AV non-stabilized power supplies



4AV21/23

4AV20/22/24/26

4AV4

4AV3

4AV5

Filtered for supply of electronic controls		4AV21/23	4AV20/22/24/26	4AV4	4AV3	4AV5
Ripple		< 5 %	< 5 %	< 5 %	< 5 %	< 5 %
Phase		1	1	1	3	3
Rated input voltage	V AC	115 ... 415	115 ... 415	230 ... 415	200 ... 600	400 ... 415
Rated output voltage	V DC	24	24	24	24	24
acc. to EN 61131-2 suitable for SIMATIC systems						
Rated output current	A	1 ... 4.2	2.5 ... 18	1.5 ... 10	15 ... 180	25, 35
Connection		Screw terminals/ flat connectors	Screw terminals/ flat connectors or Cage Clamp terminals	Screw terminals/ flat connectors or Cage Clamp terminals	Screw terminals/ flat connectors	Screw terminals/ flat connectors
Mounting		Standard rail mounting	Screw and/or standard rail mounting	Screw and/or standard rail mounting	Screw mounting	Screw mounting
cULus approval at 60 °C		Yes	Yes	No	Partially	No

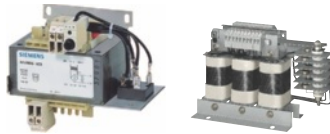

4AV98

4AV96

Unfiltered for supply of general loads		4AV98	4AV96
Ripple		48.3 %	< 5 %
Phase		1	3
Rated input voltage	V AC	230 or 400	400
Rated output voltage	V DC	24	30-27-24
Rated output current/ rated power		50 ... 500 W	4 ... 25 A
Connection		Screw terminals/ flat connectors	Screw terminals/ flat connectors
Mounting		Screw mounting	Screw mounting
cULus approval		No	No

6EP stabilized power supplies¹⁾6EP1¹⁾
LOGO!Power6EP1¹⁾
SITOP smart6EP1¹⁾
SITOP modular6EP1¹⁾
SITOP uninterruptible

		6EP1 ¹⁾ LOGO!Power	6EP1 ¹⁾ SITOP smart	6EP1 ¹⁾ SITOP modular	6EP1 ¹⁾ SITOP uninterruptible
Phase		1	1, 3	1, 2, 3	1
Rated input voltage	V	100 ... 240 AC	48 ... 220 DC, 120 ... 230 AC, 120/230 AC, 3 AC 400 ... 500	120/230 ... 500 AC, 120/230 AC, 3 AC 400 ... 500	24 DC
Rated output voltage	V DC	5, 12, 15, 24	24, 48, 3 ... 52	24	24
Rated output current	A	1.3 ... 6.3	0.375 ... 10	5 ... 40	6, 15, 40
Connection		Screw terminals	Screw terminals	Screw terminals	Screw terminals
Mounting		Standard rail mounting	Standard rail mounting	Standard rail mounting	Standard rail mounting
Approval		UL, cUL	UL, cUL	UL, cUL	UL, cUL

Further products for power supplies can be found in Catalog KT 10.1 or on the Internet at <http://www.siemens.com/sirius-supplying> and <http://www.siemens.com/sitop>.

¹⁾ For more information see Catalog KT 10.1 "SITOP Power Supplies and LOGO!Power".

Overview

4AV2, 4AV3, 4AV4 and 4AV5 power supplies deliver a non-stabilized DC voltage of 24 V DC based on single-phase or three-phase safety transformers with downstream rectifiers and capacitor filtering.

Design

The 4AV2, 4AV3, 4AV4 and 4AV5 power supplies are single-phase or three-phase transformers with downstream rectifiers in two-pulse (B2) or six-pulse (B6) bridge connection with capacitor filtering. They comply with safety class I.

The safety transformers used are designed according to EN 61558-2-6 and support the protective separation of protective extra-low voltage (SELV) and extra-low voltage (FELV) circuits from other circuits. The transformers are completely impregnated with polyester resin for protection against harmful environmental influences.

4AV devices are

- Designed for fuseless protection with standard motor starter protectors;
- Equipped with additional ground connections for a simple grounding of the control circuit using a detachable connection directly on the device;
- Easy to install thanks to freely accessible fixing holes and, in some cases, by snapping onto standard mounting rails.
- Connected with varistors and metalized dielectric capacitors for damping high-frequent overvoltages;
- Available for standard IEC voltages 230/400 V, and the multi-voltage versions allow connection to the most commonly available mains voltages worldwide up to 600 V.

Types 4AV21 and 4AV23 are protected by an integrated solid-state fuse. The output is automatically reconnected after the short cooling time following a mains disconnection or load shedding. For the 4AV4 types, short-circuit and overload protection is provided by an integrated replaceable melting fuse on the secondary side.

Protective devices

For reliable protection against short-circuits, overload and touch, the cables between the output terminals of the power supply and the load must have a negligible line impedance. For more details see DIN VDE 0100 (Erection of low-voltage systems) Part 410, Part 520 (particularly section 525) and part 600 (see also IEC 60364-4-41, -5-52 and -6).

Terminals

Screw/flat connectors

The 4AV power supplies are supplied as standard with screw/flat connectors (except: 4AV38, secondary with flat connectors).

Cage Clamp terminals

For conductor cross-sections 0.8 mm² to 4 mm² and currents up to 24 A.

The 4AV20, 4AV22, 4AV24, 4AV26 and 4AV41 single-phase units can be supplied, if required, with screwless Cage Clamp terminals (multi-voltage version is not possible). The grounding terminal is designed as a Cage Clamp terminal.

The terminals used are:

- Finger-safe according to EN 50274
- Suitable for conductor cross-sections according to VDE 0298-4 and EN 60204-1.

Mounting

Standard version

The 4AV power supplies (except: 4AV21/4AV23) are supplied in the standard version for screw fixing to the mounting plate.

Standard rail mounting

- **Integrated version**
For mounting onto standard mounting rails (horizontal mounting position), types 4AV20, 4AV41 03 and 4AV41 06 are equipped as standard with an integrated snap-on mounting for 35 mm standard mounting rails to EN 60715. Types 4AV21 and 4AV23 are only suitable for standard rail mounting.

- **Optional version**
Types 4AV22, 4AV24, 4AV41 01 and 4AV41 10 are available on request with a preassembled adapter for fixing on a 35 mm standard mounting rail.

Additional capacitors for 4AV3 (aluminum electrolyte)

Types 4AV30 to 4AV38 can be supplied with additional capacitors. This is how the values in the "Selection and ordering data" are achieved.

The back-up time is applicable for: $U_1 = U_{1N} - 10\%$

Function

The 4AV power supplies comply with EN 61131-2, irrespective of the load (no load up to rated current) and also irrespective of fluctuations of the mains voltage (+6 % to -10 % according to IEC 60038).

Despite variations in these parameters, the electronic control is supplied with the permissible operational voltage without having to select suitable tapplings on the transformer to step up or step down the DC output voltage according to load and mains conditions. The transformers are dimensioned in their voltage stability for this application.

Any number of units of the same type can be connected in parallel if a higher current level is required. The total current in this case must not overshoot 90 % of the individual rated currents.

4AV Non-Stabilized Power Supplies

Filtered for Supply of Electronic Controls

General data

Technical specifications

Single- and three-phase DC power supplies

24 V DC voltage Limit values	EN 61131-2	Typical value				Conditions
		4AV2	4AV3	4AV4	4AV5	
Ripple	≤ 5 %	2.2 ... 2.7 %	4.2 %	3.0 ... 3.7 %	4.2 %	At rated current
24 V DC voltage						
• Upper limit	30 V	≤ 28.8 V	≤ 28.8 V	≤ 30 V	≤ 30 V	For mains overvoltage +6 % and no-load operation
• Lower limit						For mains undervoltage –10 % and rated current
- Arithmetic mean value	20.4 V	20.4 V	20.5 V	20.4 V	20.4 V	
- Lower peak value	19.2 V	19.3 V	19.3 V	19.2 V	19.2 V	
• Rated value		23.5 V	23.5 V	23.5 V	23.5 V	For rated mains voltage and rated current

Current-carrying capacity of the power supplies with 3RT1 contactors for DC operation

- Sizes S00 to S3 with DC solenoid systems:
power at closing = power when closed. The DC power supplies can be loaded up to their rated currents.
- Sizes S6 to S12:
When operating the rectifiers at –10 % mains undervoltage.

Contactors	Number of 3RT1 ¹⁾ contactors that can be operated simultaneously with preloading																									
	4AV20/ 4AV21		4AV23		4AV22		4AV24		4AV26		4AV30		4AV31		4AV32		4AV33		4AV34		4AV35		4AV36		4AV38	
Type	①	②	①	②	①	②	①	②	①	②	①	②	①	②	①	②	①	②	①	②	①	②	①	②	①	②
3RT1.5	--	--	--	--	1	1	2	1	3	1	2	1	3	2	4	2	7	5	8	5	14	10	22	16	42	30
3RT1.6	--	--	--	--	1	1	1	1	2	1	1	1	2	1	2	1	4	3	4	3	7	5	11	8	22	15
3RT1.7	--	--	--	--	--	--	1	--	1	--	1	--	1	1	2	1	3	2	3	2	5	4	9	6	16	12

① No-load operation

② Rated current

¹⁾ The number of contactors can be significantly increased by using additional banks of capacitors which must be connected externally.

4AV Non-Stabilized Power Supplies

Filtered for Supply of Electronic Controls

General data

Primary-side short-circuit protection, secondary-side short-circuit and overload protection

Rectifier unit	Ambient temperature t_a	Rated output current I_d	Primary-side protection against short-circuits (line protection) by means of motor starter protector ¹⁾ or fuse, gL/gG operational class								Secondary-side protection against short-circuit and overload by means of motor starter protector or fuse, operational class	
			Type	Rated input voltage U_{1N}								Type
Type	°C	DC A		575 V (600 V)	500 V	460 V (480 V)	400 V (415 V)	230 V (240 V)	200 V	115 V (120 V)		
Single-phase												
4AV21	60	1	3RV10 11-□□□10 Set value in A	--	--	--	OCA	OFA	--	OJA	Built-in electrical short-circuit/overload protection fuse	--
	40	1.2	3RV10 11-□□□10 Set value in A	--	--	--	ODA	OFA	--	OJA		
4AV20	60	2.5	3RV10 11-□□□10 Set value in A	--	--	--	OFA	OHA	--	1BA	3RV10 11-□□□10 Set value in A	1DA
	40	3	3RV10 11-□□□10 Set value in A	--	--	--	0.4	0.6	--	1.6		2.5
4AV23	60	3.5	3RV10 11-□□□10 Set value in A	--	--	--	0.48	0.72	--	1.9		3
	40	4.2	3RV10 11-□□□10 Set value in A	--	--	--	0.55	0.7	--	2	Built-in electrical short-circuit/overload protection fuse	--
4AV22	60	5	3RV10 11-□□□10 Set value in A	--	--	--	0.66	0.84	--	2.4		
	40	6	3RV10 11-□□□10 Set value in A	--	--	--	0.6	1.1	--	2.4	3RV10 11-□□□10 Set value in A	1GA
4AV24	60	10	3RV10 11-□□□10 Set value in A	--	--	--	0.72	1.3	--	2.9		5
	40	12	3RV10 11-□□□10 Set value in A	--	--	--	1CA	1DA	--	1GA	3RV10 11-□□□10 Set value in A	6
4AV26	60	15	3RV10 11-□□□10 Set value in A	--	--	--	1CA	1EA	--	1HA	3RV10 21-□□□10 Set value in A	1KA
	40	18	3RV10 11-□□□10 Set value in A	--	--	--	2	3.2	--	6		10
4AV41 01	40	1.5	3RV10 11-□□□10 Set value in A Fuse gL/gG A	--	--	--	0BA	ODA	--	--	Integrated blade-type fuse FK2	4 A
				--	--	--	0.15	0.27	--	--		
4AV41 03	40	3	3RV10 11-□□□10 Set value in A Fuse gL/gG A	--	--	--	0GA	OHA	--	--	Integrated blade-type fuse FK2	7.5 A
				--	--	--	0.5	0.7	--	--		
4AV41 06	40	6	3RV10 11-□□□10 Set value in A Fuse gL/gG A	--	--	--	OJA	OKA	--	--	Integrated blade-type fuse FK2	15 A
				--	--	--	0.8	1.2	--	--		
4AV41 10	40	10	3RV10 11-□□□10 Set value in A Fuse gL/gG A	--	--	--	1BA	1CA	--	--	Integrated blade-type fuse FK2	25 A
				--	--	--	1.6	2.4	--	--		
Three-phase												
4AV30	60	9/10	3RV10 11-□□□10 Set value in A	OFA	OFA	OFA	OHA	OKA	OKA	--	3RV10 11-□□□10 Set value in A	1KA
	40	11/12	3RV10 11-□□□10 Set value in A	0.4	0.4	0.4	0.6	1	1	--		9/10
4AV31	60	13.5/15	3RV10 11-□□□10 Set value in A	0.48	0.48	0.48	0.72	1.2	1.2	--	3RV10 21-□□□10 Set value in A	11/12
	40	16/18	3RV10 11-□□□10 Set value in A	0.6	0.6	0.6	1	1.6	2	--		4BA
4AV32	60	18/20	3RV10 11-□□□10 Set value in A	0.72	0.72	0.72	1.2	1.9	2.4	--	3RV10 31-□□□10 Set value in A	14/15
	40	21.5/24	3RV10 11-□□□10 Set value in A	0.6	1	1	1	1.6	2.4	--		16/18
4AV33	60	27/30	3RV10 11-□□□10 Set value in A	0.72	1.2	1.2	1.2	1.9	2.9	--	3RV10 31-□□□10 Set value in A	4DA
	40	32.5/36	3RV10 11-□□□10 Set value in A	1CA	1CA	1CA	1CA	1EA	1FA	--		18/20
4AV34	60	36/40	3RV10 11-□□□10 Set value in A	1.8	1.8	1.8	2	3.2	4	--	3RV10 31-□□□10 Set value in A	21.5/24
	40	43/48	3RV10 11-□□□10 Set value in A	2.2	2.2	2.2	2.4	3.8	4.8	--		4FA
4AV35	60	45/50	3RV10 11-□□□10 Set value in A	2	2	2	2.4	3.8	4.8	--	3RV10 41-□□□10 Set value in A	28/30
	40	54/60	3RV10 11-□□□10 Set value in A	2.4	2.4	2.4	2.9	6	6	--		32.5/36
4AV36	60	80	3RV10 11-□□□10 Set value in A	2	2	2	2.4	3.8	4.8	--	3RV10 41-□□□10 Set value in A	4HA
	40	96	3RV10 11-□□□10 Set value in A	2.4	2.4	2.4	2.9	6	6	--		36/40
4AV38	60	150	3RV10 11-□□□10 Set value in A	1DA	1DA	1EA	1FA	1HA	1HA	--	3RV10 41-□□□10 Set value in A	43/48
	40	180	3RV10 21-□□□10 Set value in A	2.4	2.4	3.2	4	6	6	--		4JA
4AV51 25	40	25	3RV10 11-□□□10 Set value in A Fuse gL/gG A	2.9	2.9	3.8	4.8	7.2	7.2	--		45/50
				--	--	--	--	--	--	--		54/60
4AV51 35	40	35	3RV10 11-□□□10 Set value in A Fuse gL/gG A	--	1HA	--	1HA	--	--	--	3RV10 41-□□□10 Set value in A	4MA
				--	6	--	6	--	--	--		80
4AV51 35	40	35	3RV10 11-□□□10 Set value in A Fuse gL/gG A	--	7.2	--	7.2	--	--	--		96
				--	1KA	--	1KA	--	--	--	3VL27 16-1DC33-0AA0 Set value in A	150/800
4AV51 35	40	35	3RV10 21-□□□10 Set value in A	--	10	--	12	--	--	--	3VL37 20-1DC36-0AA0 Set value in A	180/1000
				--	4AA	--	4AA	--	--	--		
4AV51 35	40	25	3RV10 11-□□□10 Set value in A Fuse gL/gG A	--	12	--	14	--	--	--		
				--	--	--	--	--	--	--	3RV10 31-□□□10 Set value in A	4EA
4AV51 35	40	35	3RV10 11-□□□10 Set value in A Fuse gL/gG A	--	--	--	1BA	--	--	--		25
				--	--	--	1.6	--	--	--		25
4AV51 35	40	35	3RV10 11-□□□10 Set value in A Fuse gL/gG A	--	--	--	2	--	--	--		25
				--	--	--	1CA	--	--	--	3RV10 31-□□□10 Set value in A	4FA
4AV51 35	40	35	3RV10 11-□□□10 Set value in A Fuse gL/gG A	--	--	--	2.4	--	--	--		35
				--	--	--	4	--	--	--		35

¹⁾ In the event of a short-circuit on the feeder lines between the protective device and the input side of the unit, the rated short-circuit breaking capacity of the protection equipment must be taken into account with regard to the maximum possible prospective short-circuit current at the place of installation.

4AV Non-Stabilized Power Supplies

Filtered for Supply of Electronic Controls

4AV2, 4AV4 power supplies,
filtered, single-phase

Overview

- Rated output voltage U_{2N} 24 V DC according to EN 61131-2¹⁾ and SIMATIC at input voltage +6 % to -10 % and load 0 % to 100 %
- Safety transformer according to EN 61558-2-6
- 4AV21, 4AV23: **cULus** at 60 °C, ; 4AV20, 4AV22, 4AV24, 4AV26: **cULus** at 60 °C, ; 4AV41:
- 4AV2: $t_a = \text{max. } 60 \text{ °C/B}$,
4AV41: $t_a = 40 \text{ °C/B}$
- Varistor suppressor circuit
- Status LED
- EMC according to EN 62041:
 - 4AV2: Suitable for connection to the public supply (residential environments) and industrial networks (industrial environments);
 - 4AV4: Suitable for connection to industrial networks (industrial environments)
- Ripple < 5 %

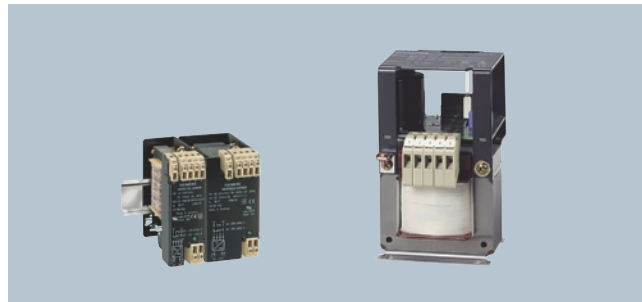

4AV21, 4AV23 (left) and 4AV20, 4AV22 to 4AV24 (right)

¹⁾ EN 61131-2: equipment specification for power supply and interface for programmable controllers. For limit values for 24 V DC see "Technical specifications".

Schematics

Terminal designations and terminal assignments

	Rated input voltage U_{1N} V	Primary connections and links		
		Rated voltage U_{1N} V	Terminals	Links
 NSF0_00045c 1 2 3 4 32 31 4AV21 02, 4AV23 02	Type 4AV21 02 and 4AV23 02			
	230 (240) - 115 (120)	230 (240) 115 (120)	1-4 1-4	2-3 1-3, 2-4
 NSF0_00046c 1 2 32 31 4AV21 06, 4AV23 06	Type 4AV21 06 and 4AV23 06			
	400 (415)	400 (415)	1-2	--
 NSF0_00047b 3 32 4 31 1 2 3 4 5 1)	Type 4AV2. 00			
	400 (415) - 230 (240) ± 15	415 400 (415) 385 245 230 (240) 215	5-3 1-3 4-3 5-2 1-2 4-2	-- -- -- -- -- --
	Type 4AV2. 01			
	400 (415) - 230 (240) - 115 (120)	400 (415) 230 (240) 115 (120)	1-5 1-4 1-4	2-3 2-3 1-3, 2-4
	Type 4AV41			
400 230 ± 15	415 400 385 245 230 215	400 V + 15 V 400 V 0 V 400 V - 15 V 230 V + 15 V 230 V 0 V 230 V - 15 V	-- -- -- -- -- --	
 NSF0_00178a M M L+ 1)	1) For Cage Clamp terminals, the ground connection is routed to the terminal. The order of terminal assignments then changes as follows .			

¹⁾ For Cage Clamp terminals, the ground connection is routed to the terminal.
The order of terminal assignments then changes as follows .



NSF0_00163

4AV Non-Stabilized Power Supplies

Filtered for Supply of Electronic Controls

4AV3, 4AV5 power supplies, filtered, three-phase

Overview

- Rated output voltage U_{2N} 24 V DC according to EN 61131-2¹⁾ and SIMATIC at input voltage +6 % to -10 % and load 0 % to 100 %
- Safety transformer according to EN 61558-2-6
- 4AV30 to 4AV35: **cULus** at 60 °C, ; 4AV36, 4AV38, 4AV51: 
- 4AV3: $t_a = \text{max. } 60 \text{ °C/B}$, 4AV51: $t_a = 40 \text{ °C/B}$
- Varistor suppressor circuit
- Status LED
- EMC according to EN 62041:
 - 4AV3: suitable for connection to the public supply (residential environments) and industrial networks (industrial environments)
 - 4AV5: suitable for connection to industrial networks (industrial environments)
- Ripple < 5 %

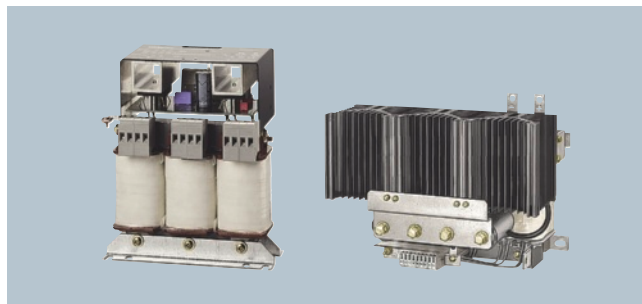

4AV30 to 4AV33 (left) and 4AV38 (right)

¹⁾ EN 61131-2: equipment specification for power supply and interface for programmable controllers. For limit values for 24 V DC see "Technical specifications".

Schematics

Terminal designations and terminal assignments

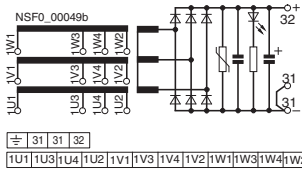
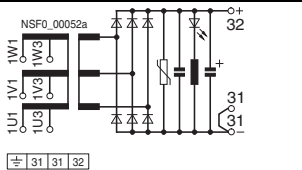
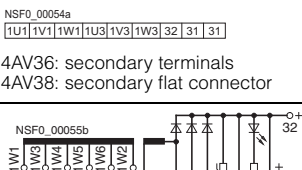
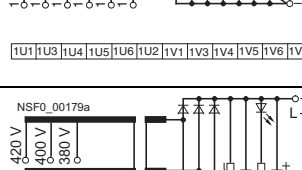
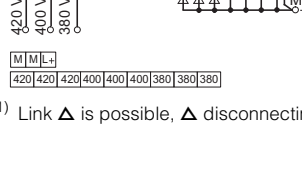
	Rated input voltage U_{1N}	Primary connections and links	
	V	Rated voltage U_{1N}	Terminals Links
 <p>NSF0_00049b</p> <p>31 31 32</p> <p>1U1 1U3 1U4 1U2 1V1 1V3 1V4 1V2 1W1 1W3 1W4 1W2</p> <p>4AV30 to 4AV35</p>	Type 4AV3. 00 400 (415) ± 20 Y 230 ± 10 Δ ¹⁾	420 400 (415) 380 240 230 220	1U1-1V1-1W1 1U1-1V1-1W1 1U1-1V1-1W1 1U1-1V1-1W1 1U1-1V1-1W1 1U1-1V1-1W1
	1U2-1V2-1W2 1U4-1V4-1W4 (=factory setting) 1U3-1V3-1W3 1U1-1W2, 1V1-1U2, 1W1-1V2 1U1-1W4, 1V1-1U4, 1W1-1V4 1U1-1W3, 1V1-1U3, 1W1-1V3		
 <p>NSF0_00052a</p> <p>31 31 32</p> <p>1U1 1U3 1V1 1V3 1W1 1W3</p> <p>4AV31, 4AV33 and 4AV35</p>	Type 4AV3. 01 500- 400 (415)	500 400 (415)	1U1-1V1-1W1 1U3-1V3-1W3 -- --
 <p>NSF0_00054a</p> <p>1U1 1V1 1W1 1U3 1V3 1W3 32 31 31</p> <p>4AV36: secondary terminals 4AV38: secondary flat connector</p>			
 <p>NSF0_00055b</p> <p>31 31 32</p> <p>1U1 1U3 1U4 1U5 1U6 1U2 1V1 1V3 1V4 1V5 1V6 1V2 1W1 1W3 1W4 1W5 1W6 1W2</p>	Type 4AV3. 02 575 (600) - 500 - 460 (480) - 400 (415) - 230 (240) - 200	575 (600) 500 460 (480) 460 (480) 400 (415) 230 (240) 200	1U1-1V1-1W1 1U3-1V3-1W3 1U4-1V4-1W4 1U5-1V5-1W5 1U5-1V5-1W5 1U6-1V6-1W6
	1U2-1V2, 1V2-1W2 1U2-1V2, 1V2-1W2 1U2-1V2, 1V2-1W2 1U2-1V2, 1V2-1W2 (= factory setting) 1U2-1V5, 1V2-1W5, 1W2-1U5 1U2-1V6, 1V2-1W6, 1W2-1U6		
 <p>NSF0_00179a</p> <p>M M L+</p> <p>420 420 420 400 400 380 380 380</p>	Type 4AV51. 5 400 ± 20	420 400 380	420 V-420 V-420 V 400 V-400 V-400 V 380 V-380 V-380 V -- -- --

¹⁾ Link Δ is possible, Δ disconnecting links are not included in the scope of supply.

4AV Non-Stabilized Power Supplies

Unfiltered for Supply of General Loads

4AV98 power supplies,
unfiltered, single-phase

Overview

The 4AV98 power supplies comprise single-phase safety transformers according to EN 61558-2-6 with downstream bridge connection rectifiers without capacitor filtering.

- Rated output voltage U_d 24 V DC
- Safety transformer according to EN 61558-2-6
- 
- $t_a = 50$ °C/B
- Varistor suppressor circuit
- Short-circuit and overload protection on the output side with top-mounted fuse
- Ripple 48 %

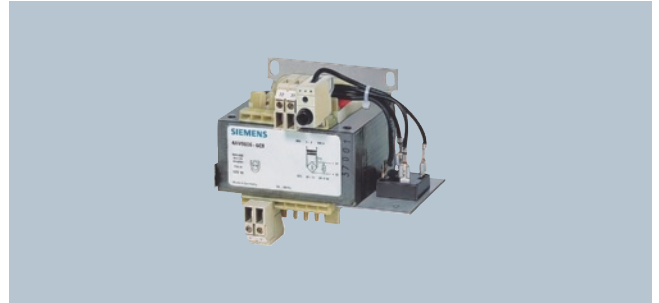

4AV98

Design

The 4AV98 power supplies comply with safety class I. The safety transformers used have been designed according to EN 61558-2-6. The transformers are completely impregnated with polyester resin for protection against harmful environmental influences.

The terminals used are

- Finger-safe according to EN 50274
- Suitable for conductor cross-sections according to DIN VDE 0100 Part 430 and EN 60204-1 (VDE 0113 Part 1)

Protective devices

For reliable protection against short-circuits, overload and touch, the cables between the output terminals of the power supply and the load must have a negligible line impedance. For more details see DIN VDE 0100 (Erection of low-voltage systems) Part 410, Part 520 (particularly section 525) and Part 600.

The integrated rectifier in a two-pulse bridge connection supplies an unregulated, unfiltered DC voltage with an arithmetic mean value of 24 V DC and a ripple of 48.3 %.

- Short-circuit and overload protection on the output side with top-mounted fuse
- Varistor protection circuit

Schematics

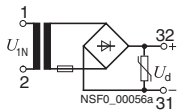

32/31

1/2

4AV Non-Stabilized Power Supplies

Unfiltered for Supply of General Loads

4AV96 power supplies,
unfiltered, three-phase

Overview

The 4AV96 power supplies comprise three-phase safety transformers according to EN 61558-2-6 with downstream bridge connection rectifiers without capacitor filtering.

- Rated output voltage U_d 30-27-24 V DC
- Safety transformer according to EN 61558-2-6
- 
- Shield winding between input and output winding
- Varistor suppressor circuit
- Designed and approved according to VW equipment specification
- Ripple < 5 %

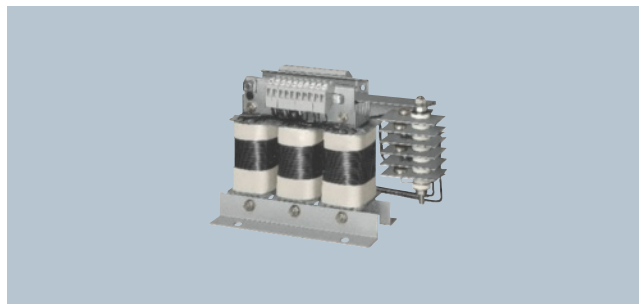

4AV96

Design

The 4AV96 power supplies comply with safety class I. The safety transformers used have been designed according to EN 61558-2-6. The transformers are completely impregnated with polyester resin for protection against harmful environmental influences.

The terminals used are

- Finger-safe according to EN 50274
- Suitable for conductor cross-sections according to DIN VDE 0100 Part 430 and EN 60204-1 (VDE 0113 Part 1)

Protective devices

For reliable protection against short-circuits, overload and touch, the cables between the output terminals of the power supply and the load must have a negligible line impedance. For more details see DIN VDE 0100 (Erection of low-voltage systems) Part 410, Part 520 (particularly section 525) and Part 600.

The integrated rectifier in a six-pulse bridge connection supplies an unstabilized, unfiltered DC voltage with an arithmetic mean value of 30/27/24 V DC and a ripple of < 5 %.

- Shield winding between input and output winding
- Varistor protection circuit
- In accordance with VW equipment specification

Technical specifications

Primary-side short-circuit and overload protection

Rectifier unit	Rated output current I_d	Primary-side short-circuit and overload protection by motor starter protectors	
		Motor starter protector	Set value at 400 V AC
Type	DC A	Type	A
4AV96 04-1CB00-2N	4	3RV10 11-0EA10	0.28
4AV96 04-5CB00-2N	12	3RV10 11-0JA10	0.8
4AV96 04-2CB00-2N	25	3RV10 11-1CA10	1.8

Schematics

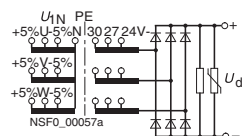

4AV Non-Stabilized Power Supplies

Project planning aids

Dimensional drawings

Filtered for supply of electronic controls

4AV2, 4AV4 power supplies, filtered, single-phase

4AV21, 4AV23,

for horizontal mounting position, snap-on mounting onto standard mounting rail TH 35 × 7.5 according to EN 60715

Technical drawing of 4AV21 and 4AV23 power supplies. Dimensions shown: 72, 136, 111, 6, B. Terminal types are indicated by circled numbers 1 and 2.

- ① Flat connector DIN 46244-A 6,3-0,8
- ② Screw terminal:
Solid 0.5 mm² ... 6 mm²,
Finely stranded 0.5 mm² ... 4 mm²

Type	Rated current	B
4AV21	1	45
4AV23	3,5	72

4AV20, 4AV22, 4AV24, 4AV26

for any mounting position,
horizontal mounting position for standard mounting rail mounting

Technical drawing of 4AV20, 4AV22, 4AV24, and 4AV26 power supplies. Dimensions shown: l₁, b₂, b₃, h₁, n₂, d₁, n₁, b₁, n₁, n₂, d₂. Terminal types are indicated by circled numbers 1 through 6.

4AV20 with integrated standard rail mounting

Input

- ① Flat connector DIN 46244-A 6,3-0,8
- ② Screw terminal:
solid 0.5 mm² ... 6 mm²,
finely stranded 0.5 mm² ... 4 mm²
- ③ Screw terminal:
solid or finely stranded 2.5 mm²
- ④ Cage Clamp terminal (also ground terminal) from the top:
solid or finely stranded 0.08 mm² ... 4 mm²

Output

- ⑤ Screw terminal:
for 4AV20 to 4AV24
solid 0.2 mm² ... 4 mm²,
finely stranded 0.2 mm² ... 2.5 mm²
for 4AV26
solid or finely stranded 0.5 mm² ... 10 mm²
- ⑥ Cage Clamp terminal:
for 4AV20 to 4AV24
solid or finely stranded 0.08 mm² ... 2.5 mm²
for 4AV26
solid or finely stranded 0.2 mm² ... 6 mm²

Type	Rated current	Designation according to DIN 41302	b ₁	b ₂	b ₃	d ₁	d ₂	h ₁	l ₁	n ₁	n ₂
4AV20	2,5	EI 84/42	89	100	51	4,8 x 9	M4	142	84	64	64
4AV22	5	EI 105/60	103	113	60	5,8 x 9	M5	157	105	83	80,5
4AV24	10	EI 120/72	123	128	67	5,8 x 9	M5	170	120	104	90
4AV26	15	EI 150N/58	110,5	140	58	7 x 13	M6	200	150	90	122

4AV2, 4AV4 power supplies, filtered, single-phase (continued)

4AV41,

for suspension,
horizontal mounting position for standard rail mounting

Input

- Flat connector
DIN 46244-A 6,3-0,8
(does not apply to 4AV41 01)
- Screw terminal:
solid 0.5 mm² ... 6 mm²,
finely stranded
0.5 mm² ... 4 mm²
- Screw terminal:
solid or finely stranded
2.5 mm²
- Cage Clamp terminal
(from the top):
solid or finely stranded
0.08 mm² ... 4 mm²

Output

- GMKDS 3 terminal
(Phoenix):
solid 0.2 mm² ... 4 mm²,
flexible 0.2 mm² ... 2.5 mm²,
current carrying capacity 10 A
- Cage Clamp terminal
(from the top):
solid or finely stranded
0.08 mm² ... 2.5 mm²

4AV41 03 and
4AV41 06 with
integrated
standard rail
mounting

Type	Rated current A DC	Designation according to DIN 41302	b ₁	b ₂	b ₃	d ₁	d ₂	h ₁	l ₁	n ₁	n ₂
4AV41 01	1,5	EI 78/26	59,5	73	35	8	M4	123	78	48,5	56
4AV41 03	3	EI 84/42	89	88	50	8	M4	145	84	64	64
4AV41 06	6	EI 96/58	103	108	57	9	M5	152	96	86,5	84
4AV41 10	10	EI 120/52	101,5	105	54	9	M5	170	120	85	90

Standard rail mounting

For 4AV DC power supplies in a special version with a preassembled adapter plate,
for horizontal mounting position

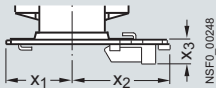

4AV20, 4AV41 03 und 4AV41 06 power supplies are supplied as standard
for both screw mounting and with integrated standard rail mounting, see
Dimensional drawings 4AV2 and 4AV41.
If using standard rail mounting, the mounting position is horizontal.

Type	x ₁ max.	x ₂ max.	x ₃	Standard mount. rail mm
4AV22	b ₁ /2 +3	b ₁ /2 +8	15	35 x 15
4AV24	b ₁ /2 +3	b ₁ /2 +3	15	35 x 15
4AV41 01	b ₁ /2 +4	b ₁ /2 +16	9	35 x 7,5
4AV41 10	b ₁ /2 +3	b ₁ /2 +3	15	35 x 15

4AV Non-Stabilized Power Supplies

Project planning aids

4AV3, 4AV5 power supplies, filtered, three-phase

4AV30 to 4AV33, arrangement:

60 °C ambient temperature on vertical surfaces

40 °C ambient temperature on horizontal surfaces

Input

- ① Flat connector DIN 46244-A 6,3-0,8
- ② Screw terminal: solid or finely stranded 0.5 mm² ... 4 mm²
- ③ Screw terminal: solid or finely stranded 2.5 mm²

Output

- ④ Screw terminal: solid or finely stranded 0.5 mm² ... 10 mm²
- ⑤ Option: back-up capacitor

Type	Rated current A DC	Designation according to DIN 41302	b ₁	b ₂	b ₃	d ₁	d ₂	h ₁	l ₁	l ₂	l ₃	l ₄	n ₁	n ₂	n ₃
4AV30	10	3UI 75/25	68	115	72	5,8 x 11	M5	190	136	164	200	110	48	113	150
4AV31	15	3UI 75/40	81	115	65	5,8 x 11	M5	190	136	164	200	110	63	113	150
4AV32	20	3UI 90/30	71	115	70	7 x 13	M6	220	162	216	232	124	55	136	200
4AV33	30	3UI 90/50	95	158	102	7 x 13	M6	220	162	216	232	124	75	136	200

4AV34, 4AV35, arrangement:

60 °C ambient temperature on horizontal surfaces

40 °C ambient temperature on vertical surfaces

Input

- ① Flat connector DIN 46244-A 6,3-0,8
- ② Screw terminal: solid or finely stranded 0.5 mm² ... 4 mm²
- ③ Screw terminal: solid or finely stranded 2.5 mm²

Output

- ④ Screw terminal: solid 1 mm² ... 16 mm², finely stranded 2.5 mm² ... 16 mm²
- ⑤ Option: back-up capacitor

Type	Rated current A DC	Designation according to DIN 41302	b ₁	b ₂	b ₃	d ₁	d ₂	l ₁	n ₁	n ₂	n ₃
4AV34	40	3UI 114/38	90	165	115	7 x 11	M6	287	70	176	250
4AV35	50	3UI 114/62	114	190	127	7 x 11	M6	295	94	176	250

4AV3, 4AV5 power supplies, filtered, three-phase (continued)

4AV36 (80 A)

for arrangement on vertical surfaces, cooling fins vertical

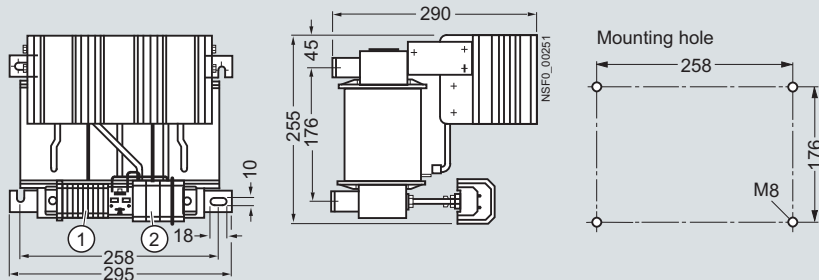

Permissible uninterrupted current when arranged on horizontal surfaces:
 52 A at $t_a = 60\text{ °C}$
 80 A at $t_a = 25\text{ °C}$

Input

- ① Screw terminal:
 solid $0.5\text{ mm}^2 \dots 6\text{ mm}^2$,
 finely stranded $0.5\text{ mm}^2 \dots 4\text{ mm}^2$
 (with or without end sleeve)

Output

- ② Screw terminal:
 solid $4\text{ mm}^2 \dots 16\text{ mm}^2$,
 finely stranded $6\text{ mm}^2 \dots 35\text{ mm}^2$
 (with or without end sleeve)

4AV38 (150 A)

for arrangement on vertical surfaces, cooling fins vertical

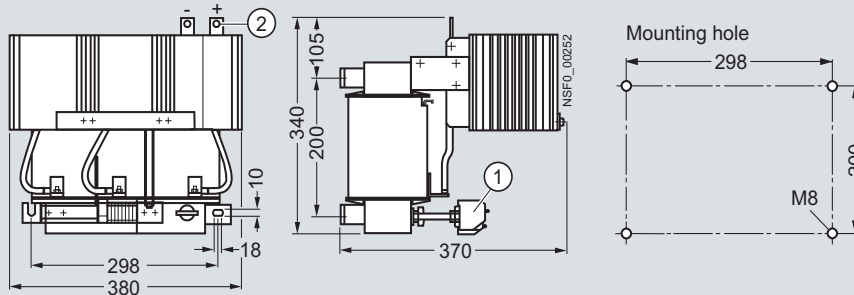

Permissible uninterrupted current when arranged on horizontal surfaces:
 100 A at $t_a = 60\text{ °C}$
 150 A at $t_a = 25\text{ °C}$

Input

- ① Screw terminal:
 solid $0.5\text{ mm}^2 \dots 6\text{ mm}^2$,
 finely stranded $0.5\text{ mm}^2 \dots 4\text{ mm}^2$
 (with or without end sleeve)

Output

Flat connectors with through-hole
 for M8 screw

Can be used for 3TX6 526-3B
 terminal cover

- ② Flat connector

4AV51

for standing/hanging mounting position

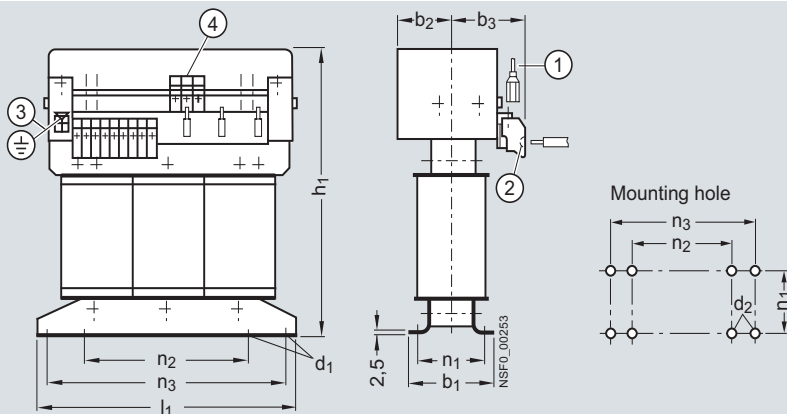
**Input**

- ① Flat connector DIN 46244-A 6,3-0,8
 ② Screw terminal:
 solid $0.5\text{ mm}^2 \dots 6\text{ mm}^2$,
 finely stranded $0.5\text{ mm}^2 \dots 4\text{ mm}^2$
 ③ Screw terminal:
 solid or finely stranded $2,5\text{ mm}^2$

Output

- ④ LUL 10,16 terminal (Weidmüller):
 solid $0.5\text{ mm}^2 \dots 10\text{ mm}^2$,
 flexible $0.5\text{ mm}^2 \dots 10\text{ mm}^2$

Type	Rated current A DC	Designation according to DIN 41302	b ₁	b ₂	b ₃	d ₁	d ₂	h ₁	l ₁	n ₁	n ₂	n ₃
4AV51 25	25	3UI 90/50	96	68	84	11	M6	240	216	76	136	200
4AV51 35	35	3UI 114/38	90	74	78	11	M6	294	266	70	176	250

4AV Non-Stabilized Power Supplies

Project planning aids

Unfiltered for supply of general loads

4AV98 power supplies, unfiltered, single-phase

4AV98 00 and 4AV98 02 for any mounting position

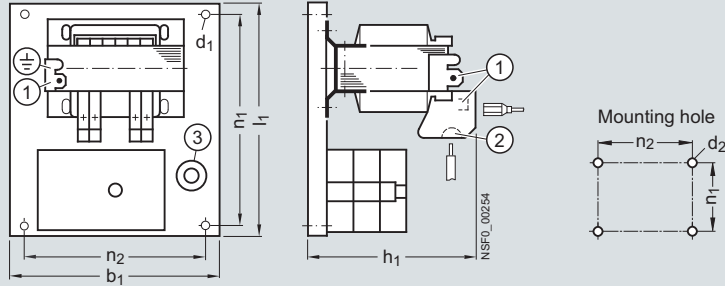

- ① Flat connector DIN 46244-A 6,3-0,8
- ② Screw terminal:
solid 0.5 mm² ... 6 mm²
finely stranded 0.5 mm² ... 4 mm²
- ③ D fuse DIN 49360

Type	Rated power W	Designation according to DIN 41302	b ₁	d ₁	d ₂	h ₁	l ₁	n ₁	n ₂	Fuses
4AV98 00-5CB... 4AV98 02-5CB..	500	EI 150N/48	193	6,8	M6	160	228	200	174	③

4AV98 06 and 4AV98 07 for any mounting position

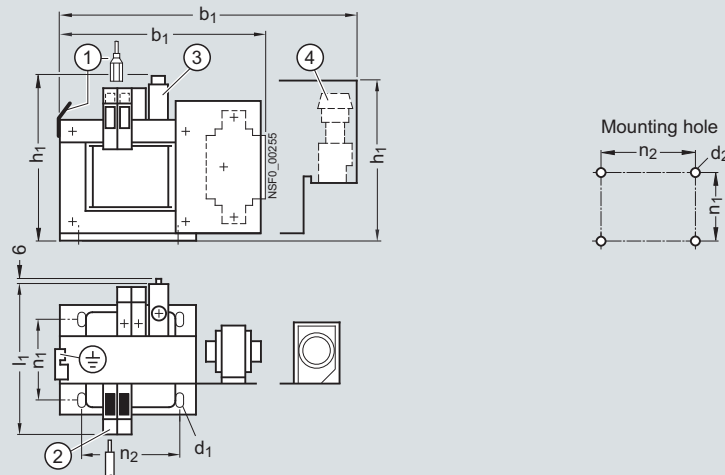

- ① Flat connector DIN 46244-A 6.3-0.8
- ② Screw terminal:
solid 0.5 mm² ... 6 mm²
Finely stranded 0.5 mm² ... 4 mm²
- ③ G fuse DIN VDE 0820 Part 22
- ④ D fuse DIN 49360

Type	Rated power W	Designation according to DIN 41302	b ₁	d ₁	d ₂	h ₁	l ₁	n ₁	n ₂	Fuses
4AV98 06-4CB..	50	EI 78/26	116	4.8 x 9	M4	96	93	48.5	56	③
4AV98 07-0CB..	50	EI 78/26	116	4.8 x 9	M4	96	93	48.5	56	③
4AV98 06-5CB..	80	EI 84/42	122	4.8 x 9	M4	101	102	63.5	64	③
4AV98 07-1CB..	80	EI 84/42	122	4.8 x 9	M4	101	102	63.5	64	③
4AV98 06-6CB..	125	EI 96/44	133	5.8 x 11	M5	113	104	73	84	③
4AV98 07-2CB..	125	EI 96/44	133	5.8 x 11	M5	113	104	73	84	③
4AV98 06-7CB..	200	EI 96/58	138	5.8 x 11	M5	113	118	86.5	84	③
4AV98 07-3CB..	200	EI 96/58	138	5.8 x 11	M5	113	118	86.5	84	③
4AV98 06-8CB..	315	EI 120/52	197	5.8 x 11	M5	134	107	85	90	④
4AV98 07-4CB..	315	EI 120/52	197	5.8 x 11	M5	134	107	85	90	④

4AV96 power supplies, unfiltered, three-phase

4AV96 04

for any mounting position,
horizontal mounting position for standard rail mounting
(4AV96 04-1CB power supply)

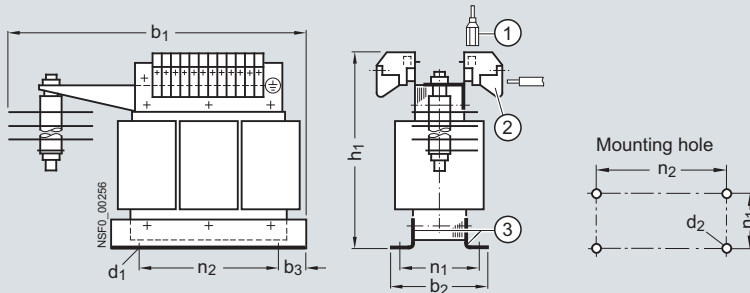

- ① Flat connector DIN 46244-A 6,3-0,8
- ② Screw terminal:
solid 0,5 mm² ... 6 mm²,
finely stranded 0,5 mm² ... 4 mm²
- ③ 4AV96 04-1CB:
Snap-on mounting for standard mounting rail
TH 35 x 7,5 acc. to EN 60715,
Horizontal mounting position

Type	Rated power W	Designation according to DIN 41302	b ₁	b ₂	b ₃	d ₁	d ₂	h ₁	n ₁	n ₂
4AV96 04-1CB..	4	3UI 60/30	180	90	15	5 x 10	M4	140	49	90
4AV96 04-5CB..	12	3UI 75/40	149	112	7	6,4 x 15	M6	190	94	111
4AV96 04-2CB..	25	3UI 90/50	300	114	35	8,5 x 12	M8	190	90	139

4AV Non-Stabilized Power Supplies

Notes



Planning and Configuration with SIRIUS

More details and up-to-date information about "Planning and Configuration with SIRIUS" can be found:

- In Catalog LV 1
- In our Mall
- On the DVD CA 01



Planning and Configuration with SIRIUS

Notes

12



SENTRON Multifunction Measuring Instruments



PAC3200 Multifunction Measuring Instruments

- 13/2 - Overview
- 13/4 - Design
- 13/5 - Function
- 13/6 - Integration
- 13/7 - Configuration
- 13/8 - Technical specifications
- 13/12 - Dimensional drawings
- 13/13 - Schematics

Expansion Modules

PAC PROFIBUS DP

- 13/16 - Technical specifications
- 13/16 - Dimensional drawings
- 13/16 - More information

PAC RS485

- 13/17 - Technical specifications
- 13/17 - Dimensional drawings
- 13/17 - More information

SENTRON Multifunction Measuring Instruments

PAC3200 multifunction measuring instruments

Overview

Measuring precisely with **SENTRON PAC3200** - New dimensions with the multifunction measuring instrument



The SENTRON PAC3200 is a control panel instrument for measuring and indicating more than 50 electric power distribution variables such as voltage, current, power, electrical work and frequency with their minimum, maximum and mean values. It convinces through its compact design and high performance capacity.

A large, backlit graphic display can be read even from great distances. User-friendly, intuitive operation is made possible by plain text displays in nine languages in combination with four function buttons. Language selection is possible either directly on the device or using configuration software. SENTRON PAC3200 offers several communication options in addition to one digital input and one digital output. For integration in a higher-level power management system it is possible to use either the integrated Ethernet interface or the optionally available expansion modules.

SENTRON PAC3200 is also available with UL and CSA approval for use in the USA and Canada.

The SENTRON powerconfig software for user-friendly device configuration is included in the scope of supply.

The product variants of the SENTRON PAC3200

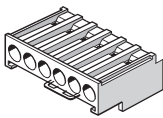
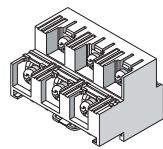
	PAC3200	Type
 With screw terminals	With AC/DC power supply unit with wide voltage range and screw terminals • U_{AUX} : 95 ... 240 V AC $\pm 10\%$, 50/60 Hz 110 ... 340 V DC $\pm 10\%$ • U_0 : max. 3 AC 690/400 V, 50/60 Hz	7KM2112-0BA00-3AA0
	With DC power supply unit with extra-low voltage and screw terminals • U_{AUX} : 22 ... 65 V DC $\pm 10\%$ • U_0 : max. 3 AC 500/289 V	7KM2111-1BA00-3AA0
 With cable lug terminals	With AC/DC power supply unit with wide voltage range and cable lug terminals • U_{AUX} : 95 ... 240 V AC $\pm 10\%$, 50/60 Hz 110 ... 340 V DC $\pm 10\%$ • U_0 : max. 3 AC 690/400 V, 50/60 Hz	7KM2112-0BA00-2AA0

These connections are indicated in the Technical specifications by orange backgrounds.

More information is available on the Internet at:
<http://www.siemens.com/powermanagementsystem>

The advantages of the SENTRON PAC3200 at a glance:

- Three-phase control panel measuring device for measuring electrical variables
- Measuring more than 50 variables such as phase voltage and phase-to-phase voltage, current, power, work, power factor, frequency, etc.
- High measuring accuracy for electrical work; Class 0.5S according to IEC 62053-22
- Can be used for single-phase measurements as well as for multiphase measurements in 3 and 4-conductor networks
- Can be connected directly to three-phase industrial networks up to 690/400 V or up to max. 500/289 V for devices with DC power supply unit with extra-low voltage (CATIII)
- Measuring higher voltages using a voltage transformer; adjustable transformer ratio
- For x/1A and x/5A current transformers. Adjustable transformer ratio and current direction
- 2 device types available with power supply unit with wide voltage range and with extra-low voltage in order to cover all standard AC and DC auxiliary voltage supply needs
- Slot for expansion modules such as the SENTRON PAC PROFIBUS DP or SENTRON PAC RS485 communication modules
- Small space requirement thanks to compact design (96 mm x 96 mm, mounting depth 51 mm or 73 mm with module)
- Large, graphic LCD display with intuitive user operation using function buttons
- Menu selections, test displays and documentation available in nine languages (German, English, Portuguese, Turkish, Spanish, Italian, French, Chinese and Russian)
Language selection on the device or using configuration software
- IP65 using standard sealing
- Multifunctional digital input, for example for detecting counting pulses or for monitoring the status of switching devices
- Multifunctional digital output, for example for emitting active or reactive power pulses (S0) or for indicating limit value violations
- Monitoring of up to 6 limit values and connecting the limit values with logical AND/OR operations
- Measuring period averages for active and reactive power with minimum and maximum value
- Operating hours counter for indicating the load running time
- Integrated Ethernet interface (Modbus TCP or SEABus TCP) for integration in power management systems
- UL and CSA approval for the USA and Canada
- CD with SENTRON powerconfig software for user-friendly device configuration included in scope of supply

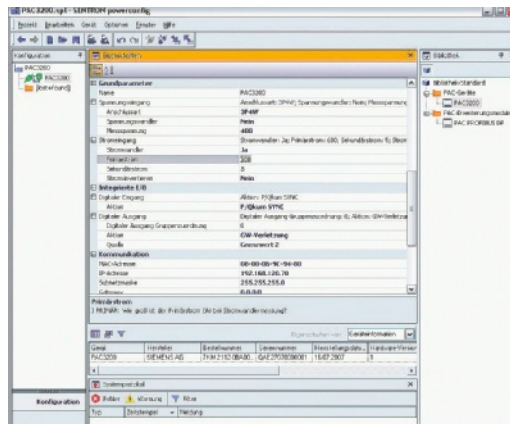

Measurement functions

The SENTRON PAC3200 measures the following variables:

Variable	Display range	L1/L1-2	L2/L2-3	L3/L3-1	Total	Minimum value	Mean value	Maximum value
Current	0 A 120 kA	✓	✓	✓	--	✓	✓ ¹⁾	✓
Voltage L-N	0 V 700 kV	✓	✓	✓	--	✓	✓ ¹⁾	✓
Voltage L-L	0 V 1200 kV	✓	✓	✓	--	✓	✓ ¹⁾	✓
Frequency	44.00 ... 67.00 Hz	✓	--	--	--	✓	--	✓
Active power per phase input "+"/output "-"	0 W 100 GW	✓	✓	✓	--	✓	--	✓
Reactive power per phase pos./neg. or ind./cap.	0 var ... 100 Gvar	✓	✓	✓	--	✓	--	✓
Apparent power per phase	0 VA ... 100 GVA	✓	✓	✓	--	✓	--	✓
Active power total input "+"/output "-"	0 W ... 100 GW	--	--	--	✓	✓	✓ ²⁾	✓
Reactive power total pos./neg. or ind./cap.	0 var ... 100 Gvar	--	--	--	✓	✓	✓ ²⁾	✓
Apparent power total	0 VA ... 100 GVA	--	--	--	✓	✓	--	✓
Power factor per phase	0 ... 1	✓	✓	✓	--	✓	--	✓
Power factor total	0 ... 1	--	--	--	✓	✓	--	✓
Active work total input "+"/output "-"	0 Wh ... 1000 GWh	--	--	--	✓ ³⁾	--	--	--
Reactive work total pos./neg. or ind./cap.	0 varh ... 100 Gvarh	--	--	--	✓ ³⁾	--	--	--
Apparent work total	0 VAh ... 100 GVAh	--	--	--	✓ ³⁾	--	--	--
THD voltage per phase	0 ... 100 %	✓	✓	✓	--	--	--	✓
THD current per phase	0 ... 100 %	✓	✓	✓	--	--	--	✓
Voltage asymmetry	0 ... 100 %	--	--	--	✓	--	--	--
Current asymmetry	0 ... 100 %	--	--	--	✓	--	--	--
Operating hours	0 h ... 300 years	--	--	--	✓	--	--	--
Universal counter	0 ... 999 999 999 pulses	--	--	--	✓	--	--	--

¹⁾ The values quoted are mean values of all three phases.

²⁾ Can be called up only through communication. The power averages (power count values), including minimum and maximum values, are transmitted for an adjustable measurement period. The measurement period can be selected in the range 1 ... 60 min; the default setting is 15 min.

³⁾ The values for high rate and low rate are shown on the display.

✓ Measuring possible

-- Measuring not possible or not meaningful

SENTRON Multifunction Measuring Instruments

PAC3200 multifunction measuring instruments

Design

Enclosure

SENTRON PAC3200 comes with a plastic enclosure for installation in control panels. It is fastened by one holder on the right side of the device and one on the left side.

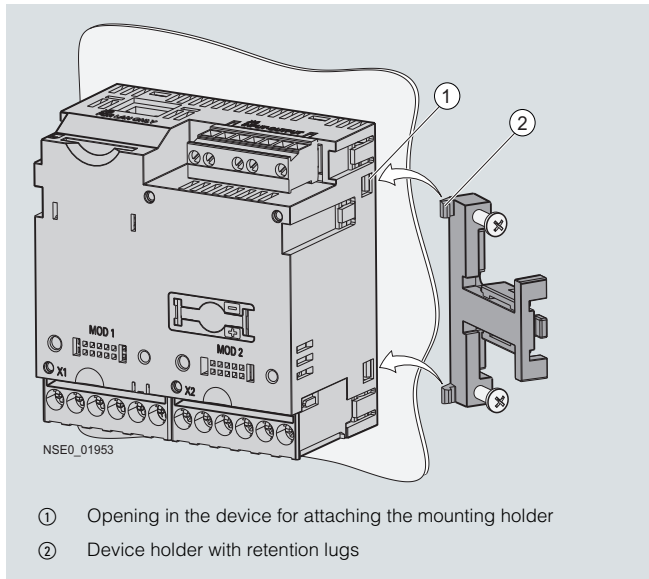

Mounting the SENTRON PAC3200

To mount the SENTRON PAC3200 it is inserted from the front through the square cut-out in the control cabinet door and secured with the supplied holders.

From the front, i. e. in the installed state, the device complies with Safety Class II with degree of protection IP65.

The following picture shows how to join together the SENTRON PAC3200 and the expansion module in the light of the rear view of the SENTRON PAC3200 and the top view of the expansion module (here: PAC PROFIBUS DP).

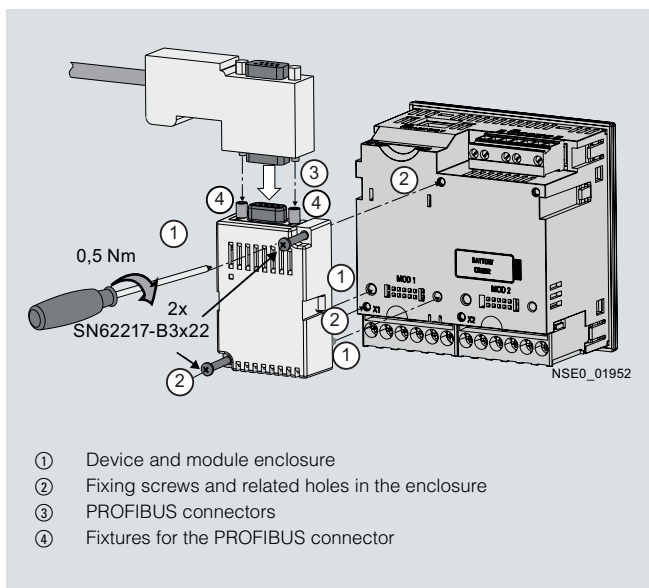

Mounting the expansion module based on the example of the PAC PROFIBUS DP on the SENTRON PAC3200

Operating and indicating elements

The following picture shows the SENTRON PAC3200 from the front, divided into the function blocks provided for operation and monitoring, including a description.

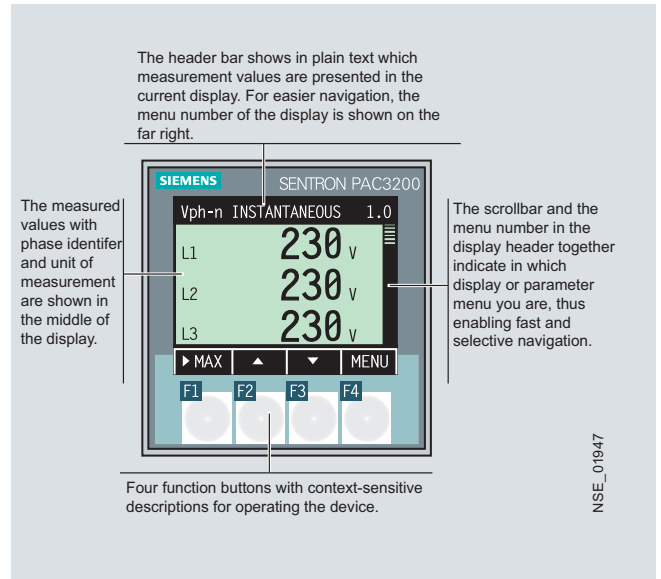

Front of the SENTRON PAC3200

The device is operated using 4 function buttons, which correspond to the 4 text fields situated above them. The buttons are each assigned with several functions; their function at any time depends on the menu then displayed. Which function a button has in the respective menu is indicated by the text in the related display.

Function

Precise measurement of variables

With its high accuracy, the SENTRON PAC3200 meets the increasing demand for precise power measurement. It satisfies the accuracy requirements of Class 0.5S according to IEC 62053-22 for solid-state active consumption meters.

Transparency in power matters

Altogether 10 power meters for active, reactive and apparent work monitor the power consumption in the system, separately according to the high rate and low rate, for both power input and power feedback.

This makes the SENTRON PAC3200 the optimum choice of data supplier for a higher-level power management system. Integrated in such a system it enables the user to record his installation's load profile.

For this purpose the SENTRON PAC3200 also supplies the required power averages for active and reactive power.

Plain-text displays

A large, full graphic LCD display enables easy reading even from great distances. To make sure that this is also the case in poor light conditions, the background lighting can be individually adapted to the actual requirements.

Operation, also multilingual

A special highlight is the intuitive user operation. Operation is quick to learn using the four function buttons together with multilingual plain text displays. Following languages can be selected: English, German, Portuguese, Turkish, Spanish, Italian, French, Chinese and Russian.

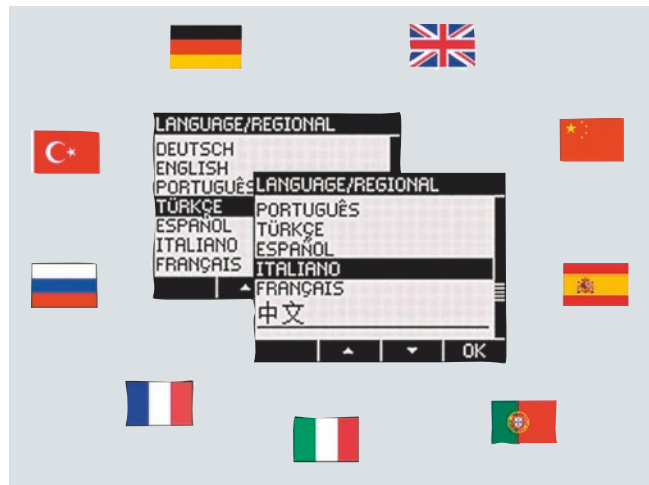

Operating languages of the PAC3200

Direct navigation is available in addition for the experienced user, who can thus call up the menus of choice even more quickly.

Mounting and start-up in the shortest possible time

With its ingenious mounting method the SENTRON PAC3200 is quick and easy to install using combination latching holders.

The pair of combination holders performs two functions:

- Thanks to the latching mechanism the fitter can fasten the device in the control panel quickly and without the use of any tools.
- If greater protection is required, the four screws of the latching holder can be used to increase its contact pressure evenly on all sides so that the control panel cut-out is cleanly sealed by the integrally molded gasket, which is a standard feature. The often bothersome and time-consuming insertion of an accessory gasket is a thing of the past.

As the result of the easy-to-use combination holders and the small mounting depth of only 51 mm it is easy to mount several devices side by side.

Powerful communication

Unique in this device class up to now is the Ethernet interface provided as a standard feature which can be used not only for configuration purposes using SENTRON powerconfig but also for system communication in a higher-level power management system. For optimum system adaptation it is possible to switch between the SEAbus TCP protocol and the Modbus TCP protocol.

The optional SENTRON PAC PROFIBUS DP and PAC RS485 expansion modules for Modbus RTU and SEAbus are available for communication in a network.

Integration in PROFIBUS takes place using a standardized text file called the GSD (Geräte-Stammdaten-Datei). This GSD file is read into the master with the help of the PROFIBUS configuration tool. The master thus receives the slave-specific framework of the PAC3200 and can start cyclic operation immediately.

Integration in Modbus RTU or SEAbus systems takes place through parameterization of the device address and baud rate using the device keyboard or SENTRON powerconfig.

Multifunctional digital input and output

The SENTRON PAC3200 is equipped with one digital input and one digital output, to each of which various functions can be assigned.

Functions of the digital input:

- Counting input for work pulses (kWh, kvarh) from third-party devices
- Status monitoring of a switching device
- Rate switchover between high rate and low rate
- Signal input for synchronization of the measurement period

Functions of the digital output:

- Pulse output for sending work pulses (kWh, kvarh)
- Alarm output for signaling limit value violations
- SENTRON PAC3200 operating state indicator
- Phase sequence indicator
- Switching output for remote control using system software

With its wide range of functions, the SENTRON PAC3200 can be used in all applications.

PAC3200 multifunction measuring instruments

Monitoring of measurement variables for limit value violations

The SENTRON PAC3200 can monitor up to 6 measurement variables for violation of an adjustable upper or lower limit value. The following variables can be monitored: voltage, current, power, power factor, THD U/I, frequency or asymmetry of voltage and current

The following can be assigned to each limit value:

- A measurement variable:
 U_{L-N} , U_{L-L} , I_L , P_L , Q_L , S_L , LF_L , $THD-U_L/I_L$ for all 3 phases and U_{L-N} , mean value, U_{L-L} , mean value, I_L , mean value, S_{tot} , P_{tot} , Q_{tot} , LF_{tot} , frequency, asymmetry U/I
- The monitoring mode (overshooting or undershooting)
- A limit value
- A delay time and
- A hysteresis

In addition the limit values can be interconnected by an AND/OR logic function. Like the individual limit values, the result of the logic operation can also trigger certain actions.

It is possible to select the action which will be triggered by violation of a limit value. For example, a signal can be sent through the digital output or the communication interface. The integrated universal counter can be used to total the number of limit value violations. Whether a limit value has been violated is indicated on the device.

Monitoring of voltage and current for asymmetry

The device measures, among other things, the asymmetry of voltage and current in the network. Now that a limit value can also be assigned to these two parameters, problems due to unsymmetrical loads in the installation can be detected early and avoided.

Operating hours counter

An important service function is performed by the integrated operating hours counter, which can be used to monitor e. g. pumps, motors or machines. The counter measures the running time of a connected load, helping to ensure that important maintenance intervals are observed. The count can be read out and evaluated by a PC. A higher-level power management system is thus able to generate a suitable maintenance message.

Universal

The SENTRON PAC3200 can be used for measuring in two, three and four-conductor networks. It is capable of measuring in three phases as well as in one and two phases.

Thanks to its large measuring voltage range, the device can be directly connected in every low-voltage system up to a rated system voltage of 690 V (U_{L-L}). Higher voltages can be measured using voltage transformers.

For measuring currents it is possible to use both x/1A and x/5A current transformers. Transformer ratios and current direction can be programmed on the device for adaptation to local conditions.

Protection against unauthorized access

The SENTRON PAC3200 comes with integrated password protection so that the power and parameter data are safe from unauthorized access. Changes to the parameterization can be traced using a configuration counter which can be read out through an interface.

Integration

Using the interface modules it is possible to integrate the SENTRON PAC3200 in every I&C system or every SIMATIC S7 environment.

When the SENTRON PAC3200 is fully integrated in a power management system, e. g. SIMATIC WinCC powerrate or SIMATIC PCS 7 powerrate, it monitors the power consumption.

At the same time the SENTRON PAC3200 helps to monitor the operating state of the installation. Measured values, limit value violations, operating hours of a connected load or power flows are supplied by the device quickly and reliably.

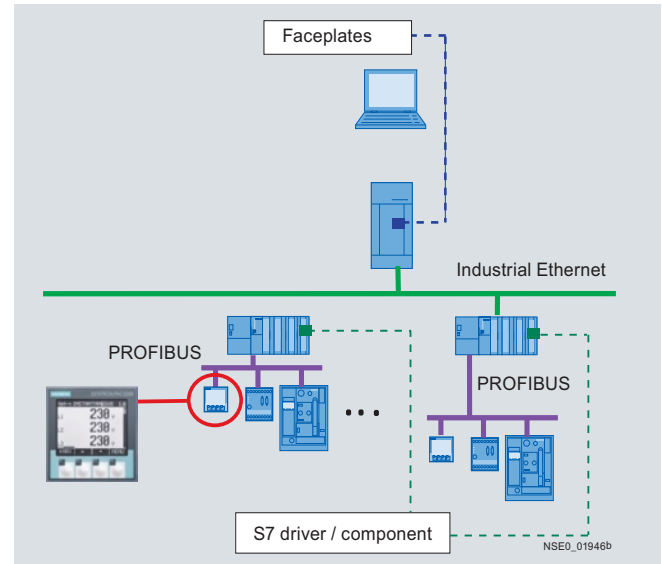

Integration of the SENTRON PAC3200 in SIMATIC PCS 7 / WinCC powerrate

Configuration

Configuration directly on the device

The SETRON PAC3200 is designed for user-friendly configuring directly on the device. All menus are displayed in plain text and are self-explanatory. No manual is required therefore.



Configuring interface of the SETRON PAC3200

Configuring with SETRON powerconfig is user-friendly

The scope of supply of the PAC3200 includes the SETRON powerconfig software for the user-friendly configuring of the PAC3200 from the PC.

The software runs on the following operating systems:

- Windows 2000 Professional SP4 and higher
- Windows XP Professional SP2 and higher

SETRON powerconfig is available in German or English, with selection possible at any time through the Options menu. The integrated online help is likewise bilingual and describes the software's functions in detail.

After SETRON powerconfig is installed, the PAC3200 can be connected to the PC in two ways:

- Using a commercially available crossover cable which connects the PAC3200 directly to the network interface of the PC
- Or using a hub/switch in an Ethernet network. In this case conventional patch cables are used.

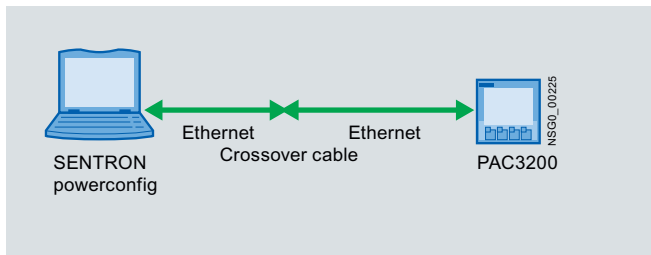

Direct connection between the PC and PAC3200

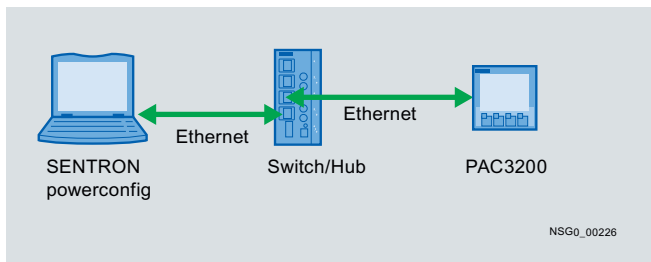

Connection between the PC and PAC3200 through a hub/switch

Note:

The required cable material is not included in the scope of supply.

Simplified making of connections through search function

SETRON powerconfig comes with a search function which facilitates the finding of all PAC3200 units connected to the same network. Making the first connection is thus easier. Both the communication status and the configuration status are indicated by symbols in the tree view.

Configuration management

With the project manager in SETRON powerconfig it is possible to save device configurations and also to copy them if required.

For the documentation of device configurations, SETRON powerconfig has a user-friendly printing function with preview feature.

Off-line device configurations

Using the offline device configurations, all the devices of a plant can be configured in the comfort of the office as follows:

- Creating the offline device configurations: All available devices and expansion modules are grouped in a library. The required PAC3200 units are selected from the library and moved into the device tree by means of Drag & Drop. Expansion modules can be added to the device tree in the same way. However, they can only be entered under a device.
- Sending the offline device configurations: During start-up, the offline device configurations can be sent to the devices as soon as they are connected to SETRON powerconfig.

User interface of SETRON powerconfig

The individual subwindows can be positioned on the monitor as required, including outside the main window of SETRON powerconfig. In this way the interface of the software can be adapted to the user's individual preferences.

The figure below shows the program interface of SETRON powerconfig by way of example.

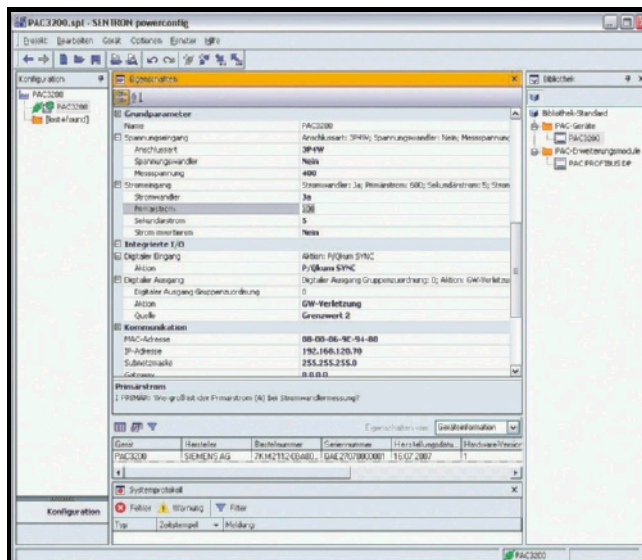

Configuring interface of SETRON powerconfig

PAC3200 multifunction measuring instruments

Technical specifications

Measurement			
Networks			
Voltage types			Only for alternating voltage systems
Number of phases			1-, 2- or 3-phase
Number of conductors			3 or 4 conductors
Load type			Same or any load
Quadrants			4 quadrants (input and output)
Frequency of fundamental wave	Hz		50/60
Signal detection			
For power, current and voltage			Seamless
Curve shape			Sinusoidal or distorted
Measuring inputs for voltage			
Rated voltage 3 AC U_e (max.)			
Device with AC/DC power supply unit with wide voltage range	7KM2112-0BA00-3AA0 or 7KM2112-0BA00-2AA0		
	Phase/N	V AC	400 (max. 347 for UL) +20 %
	Phase/phase	V AC	690 (max. 600 for UL) +20 %
Device with DC power supply unit with extra-low voltage	7KM2111-1BA00-3AA0		
	Phase/N	V AC	289 +20 %
	Phase/phase	V AC	500 +20 %
Measuring category			CAT III
Input resistance			
	Phase/N	M Ω	1.05
Power consumption			
	Per phase	mW	220
Measuring of voltages > 690 or 500 V AC using voltage transformer			
Measuring inputs for current			
Rated current 3 AC I_e per phase			
	Adjustable	AC A	1 or 5
Operating range current per phase			
	With setting 1 A	AC A	0.01 ... 1.2
	With setting 5 A	AC A	0.05 ... 6
Permanent load capacity			
	Permanent	AC A	10
Surge overload capability			
	For 1 second	AC A	100
Power consumption			
	Per phase	mVA	4 at 1A, 115 at 5A
Measuring category			CAT III
Zero point suppression			
	Adjustable	%	0 ... 10
Measuring of currents using current transformer			
Supply voltage			
Power supply unit with wide voltage range			
			AC/DC
Operating range	7KM2112-0BA00-3AA0 or 7KM2112-0BA00-2AA0	V AC	95 ... 240 \pm 10%
		V DC	110...340 \pm 10%
Rated frequency		Hz	50/60
Power supply unit with extra-low voltage			
			DC
Operating range	7KM2111-1BA00-3AA0	V DC	22 ... 65 \pm 10%
Power consumption			
Without optional expansion module		VA	6
Including optional expansion module		VA	8
Overvoltage category			CAT III

Fault limits		
Voltage	%	±0.3
Current	%	±0.2
Rating	%	±0.5
Frequency	%	±0.05
Power factor	%	±0.5
Active energy		Class 0.5S acc. to IEC 62053-22:2003-01
Reactive energy		Class 2 acc. to IEC 62053-23:2003-01
When taking measurements on external current or voltage transformers, the accuracy of the measurements depends on the quality of the transformers.		
Digital input		
Number		1
Rated value	V DC	24
Max. input voltage	V DC	30
Input threshold signal "1"	V DC	> 13
Input threshold signal "0"	V DC	< 8
Input current signal "1"	DC mA	7
Digital output		
Number		1
Required voltage	V DC	12 ... 24
Max. switched output voltage	V DC	30
Output current signal "0"	DC mA	Max. 0.2
Output current signal "1"		
Typical	DC mA	10 ... 27
Permanent	DC mA	100
Short-time overload for max. 100 ms	DC mA	300
Resistive load	DC mA	100
Switching frequency	Hz	17
Short-circuit protection		Yes
Communication		
Ethernet		RJ45 socket
Transmission rate max.	MBit/s	10
Protocol		Either SEABus TCP or Modbus TCP (selectable)
PROFIBUS DP		
Using expansion module	PAC PROFIBUS DP	
Transmission rate max.	MBit/s	V1
Variables to be transmitted		12
		Definable using GSD file
RS485		
Using expansion module	PAC RS485	
Transmission rates	kBd	Optionally 4.8/9.6/19.2/38.4
Protocol		Optionally SEABus or Modbus RTU (selectable)
Indicating and operating		
Display type		LCD, full graphic
Displays		Alphanumeric and text
Resolution	Dots	128 x 96
Size	mm	72 x 54
Contrast		Adjustable
Display		Display invertible, pos/neg mode
Background lighting		
Lighting intensity		Adjustable
Lighting intensity dimmed		Adjustable
Dimming time	min	0 ... 99
Languages		German, English, Portuguese, Turkish, Spanish, Italian, French, Chinese and Russian

PAC3200 multifunction measuring instruments

Connection elements and terminals

Measuring inputs and supply voltage

Conductor cross-sections

Solid

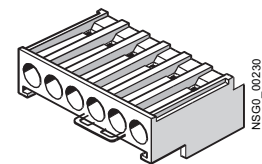
mm²
 Screw terminals
1 x 0.5 ... 4
AWG 1 x 20 ... 12mm²2 x 0.5 ... 2.5
AWG 2 x 20 ... 14

Finely stranded with end sleeve

mm²1 x 0.5 ... 2.5
AWG 1 x 20 ... 12mm²2 x 0.5 ... 1.5
AWG 2 x 20 ... 16

Tool size

± Screw, Pozidriv

2

Measuring inputs and supply voltage

Conductor cross-sections

Dependent on ring terminal lug used

mm²
 Ring terminal lug connection

1 x 1.0...6.0

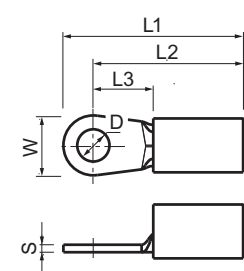
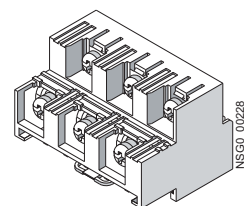

mm

AWG 1 x 18...10
D: 3...4
S: 0.75 ... 1.0
W: ≤ 8
L1: ≤ 24
L2: ≤ 20
L3: ≥ 8

Inch

D: 0.118 ... 0.157
S: 0.029 ... 0.039
W: ≤ 0.314
L1: ≤ 0.944
L2: ≤ 0.787
L3: ≥ 0.314

Tool size

± Screw, Pozidriv

2

Digital output, digital input

Conductor cross-sections

Solid

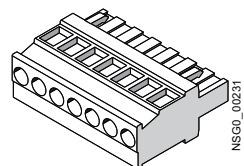
mm²
 Screw terminals
1 x 0.2 ... 2.5
mm²
2 x 0.2 ... 1.0
AWG 1 x 24 ... 12mm²

AWG 1 x 24 ... 12

Finely stranded with end sleeve

mm²

1 x 0.25 ... 2.5

mm²

2 x 0.25 ... 1.0

AWG 1 x 24 ... 12

Tool size

± Screw, Pozidriv

1

Dimensions and weights

Enclosure for installing in control panel

Acc. to IEC 61554

Enclosure dimensions (W x H x D)

Without expansion module

mm

96 x 96 x 56

With expansion module

mm

96 x 96 x 78

Mounting depth

Without expansion module

mm

51

With expansion module

mm

73

Control panel thickness

mm

0.5 ... 4

Weight

Without expansion module

Approx.

g

325

With expansion module

Approx.

g

370

Degree of protection and safety class

Safety class acc. to EN 61010-1

From the front when installed

II

Degree of protection acc. to EN 60529

All devices

On front

IP65

Device with screw terminals

Rear

IP20

Device with cable lug terminals

Rear

IP10

Ambient conditions		
Temperature range		
Operating temperature	°C	-10 ... + 55
Storage and transport temperature	°C	-25 ... + 70
Relative air humidity		
At 25 °C without condensation	%	95
Operating altitude		
Above sea level up to max.	m	2000
Degree of pollution		
		2
Safety		
Password protection		
		4-digit numeric code
Safety requirements		
Verification of suitability as EC conformity declaration - Device test according to the following standards		IEC 61010-1:2001 (2nd Ed.) with Corr.1 EN 61010-1-1:2001 (2nd Ed.) EN 61010-1:2002 with Corr.1
Verification of suitability as approval for the USA and Canada		UL 61010-1, 2nd Ed. CAN/CSA-C22.2 NO. 61010-1-04
Electromagnetic compatibility		
Emitted interference		
		IEC 61000-6-4 Group 1; Class A/CISPR11 Group 1; Class A FCC Part 15 Subpart B; Class A
Enclosure interference immunity		
Electrostatic discharge		IEC 61000-4-2:2001-04
Electromagnetic fields		IEC 61000-4-3:2006-02
Line-frequency magnetic fields		IEC 61000-4-8:2001-03
Measuring and supply voltage		
Voltage dips		IEC 61000-4-11:2004-03
Rapid transients		EN 61000-4-4:2005-07
Surge voltages		EN 61000-4-5:2001-12
Line-conducted RF signals		EN 61000-4-6:2001-12
Inputs and outputs, interfaces		
Rapid transients		IEC 61000-4-4:2004-07
Surge voltages		IEC 61000-4-5:2005-11
Line-conducted RF interference fields		EN 61000-4-6:2001-12
Mechanical dynamic stress		
Vibratory load Conditions of use/transport		
		Acc. to IEC 60068-2-6:1995-03/EN 60068-2-6:1996-05
Seismic stress		
		Acc. to IEC 60068-3-3:1991-02/EN 60068-3-3:1993-09
Shock stress		
		Acc. to IEC 60068-2-27:1987/EN 60068-2-27:1995-03
Bumping, resistance		
		Acc. to IEC 60068-2-27:1987/EN 60068-2-27:1995-03
Continuous bumping		
		Acc. to IEC 60068-2-29:1987/EN 60068-2-29:1995-03
Mechanical strength Against surges and shocks		
		Acc. to IEC 60068-2-75:1997-08

SENTRON Multifunction Measuring Instruments

PAC3200 multifunction measuring instruments

Dimensional drawings

Dimensions of multifunction measuring instrument

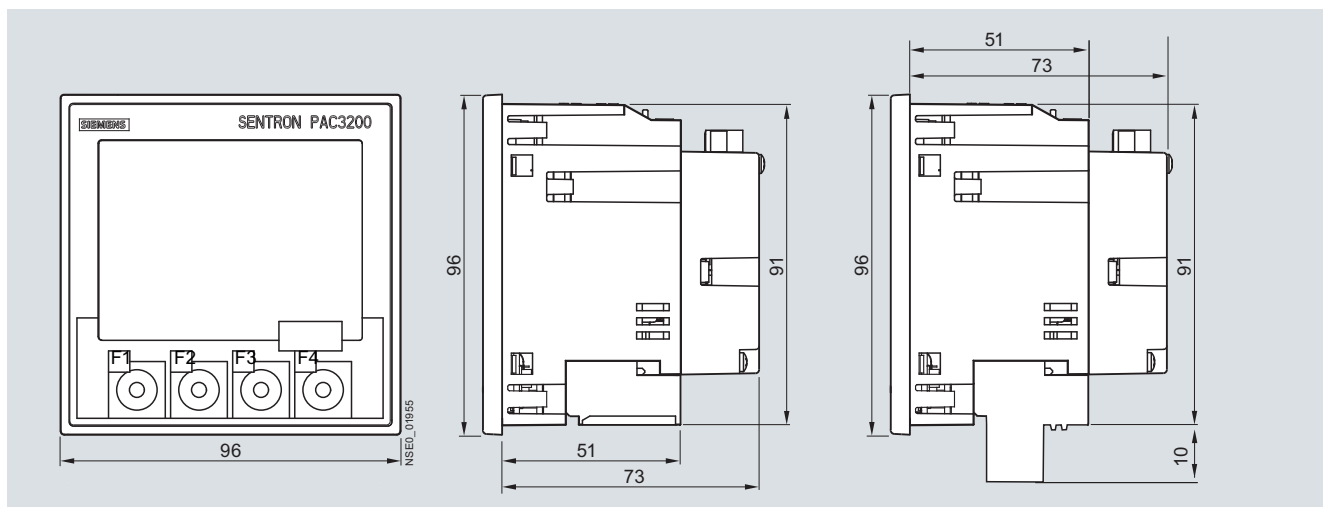

Left: Front view; middle: PAC3200 with screw terminals, view from the right; right: PAC3200 with cable lug terminals, view from the right

Control panel cut-out

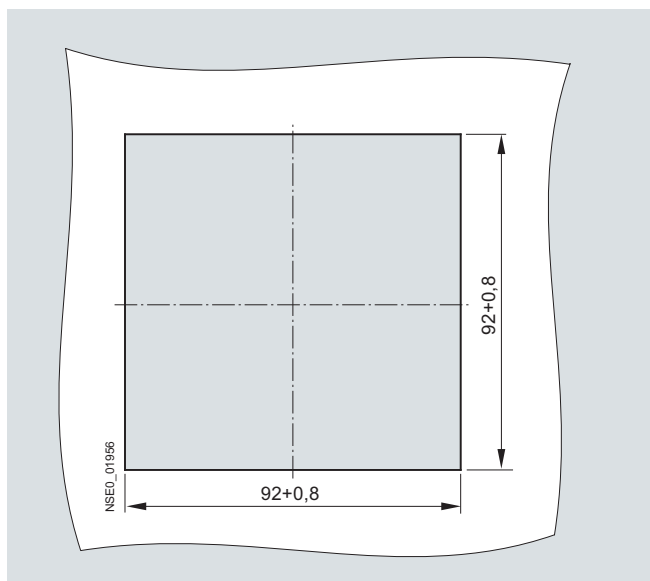

Cut-out from the front

Control panel cut-out, lateral

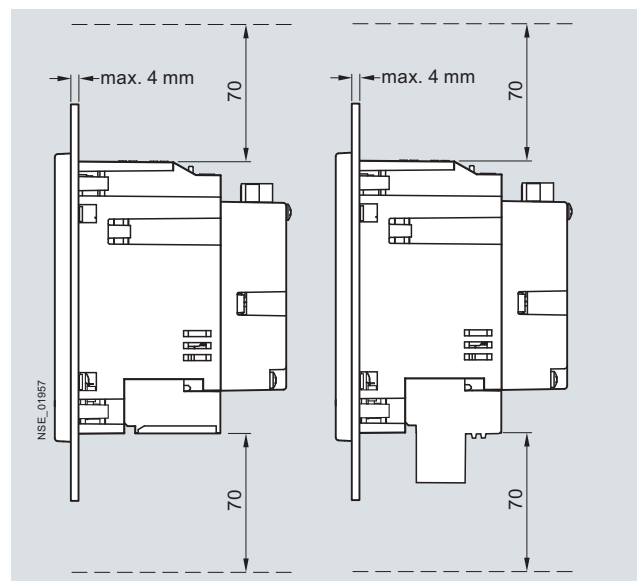

Left: PAC3200 with screw terminals, view from the right
Right: PAC3200 with cable lug terminals, cut-out from right

Mounting clearances

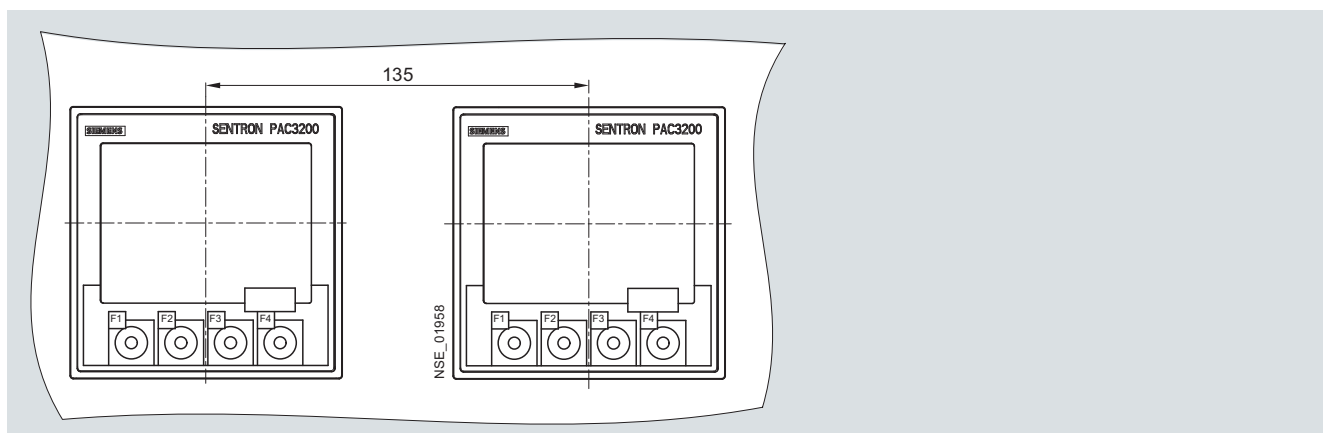

PAC3200 multifunction measuring instruments

Schematics

Connection examples

Connection example 1:

Three-phase measurement, four conductors, asymmetric load, without voltage transformer, with three current transformers

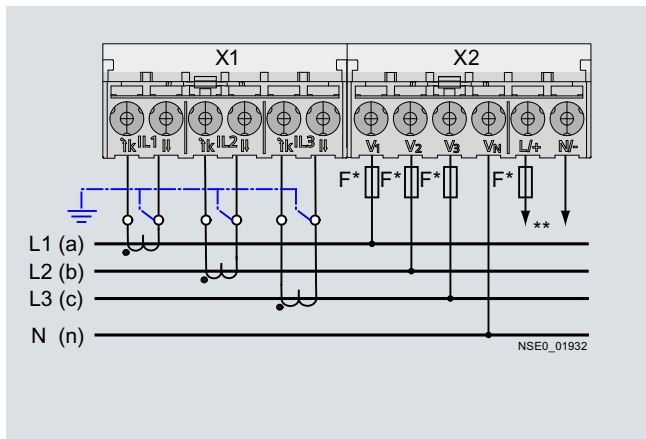

Connection example 2:

Three-phase measurement, four conductors, asymmetric load, with voltage transformer, with three current transformers

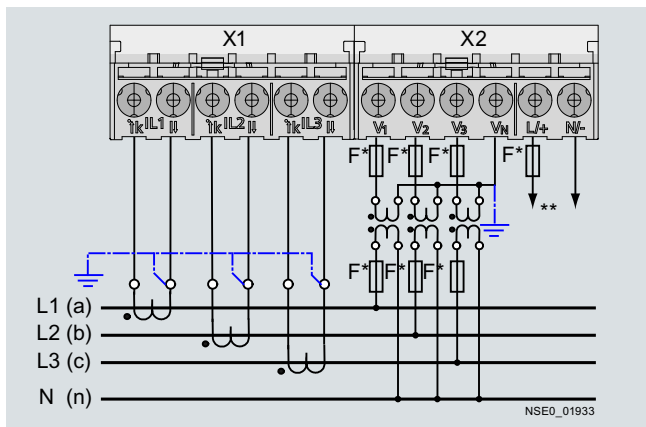

Connection example 3:

Three-phase measurement, four conductors, symmetric load, without voltage transformer, with one current transformer

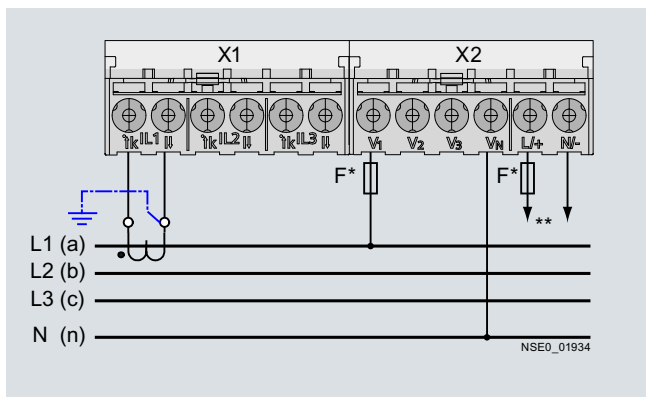

* Fuses must be provided by the user.

Connection example 4:

Three-phase measurement, four conductors, symmetric load, with voltage transformer, with one current transformer

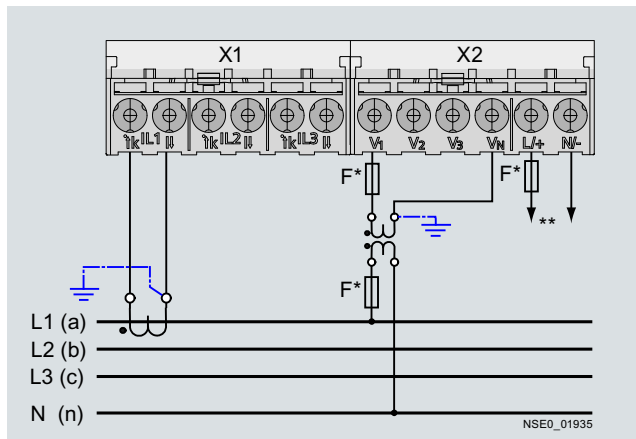

Connection example 5:

Three-phase measurement, three conductors, asymmetric load, without voltage transformer, with three current transformers

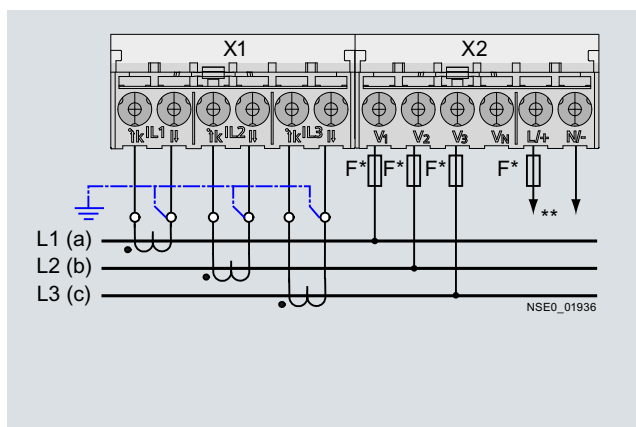

Connection example 6:

Three-phase measurement, three conductors, asymmetric load, with voltage transformer, with three current transformers

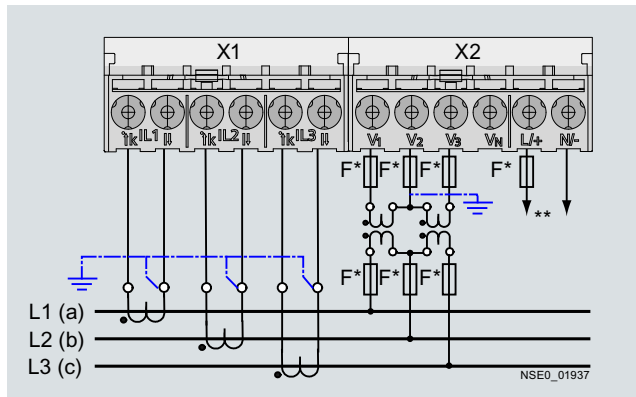

** Connection of the supply voltage.

SENTRON Multifunction Measuring Instruments

PAC3200 multifunction measuring instruments

Connection example 7:

Three-phase measurement, three conductors, asymmetric load, without voltage transformer, with two current transformers

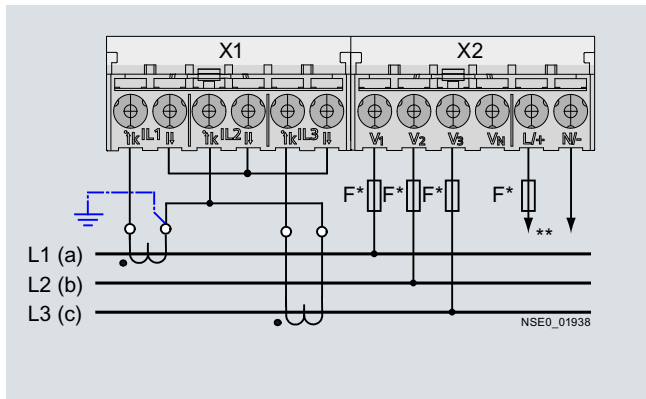

Connection example 10:

Three-phase measurement, three conductors, symmetric load, with voltage transformer, with one current transformer

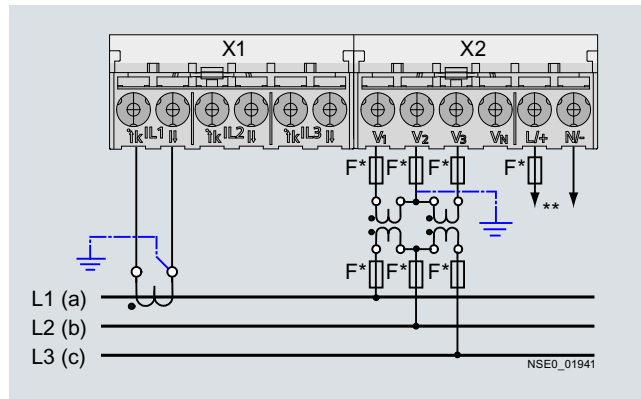

Connection example 8:

Three-phase measurement, three conductors, asymmetric load, with voltage transformer, with two current transformers

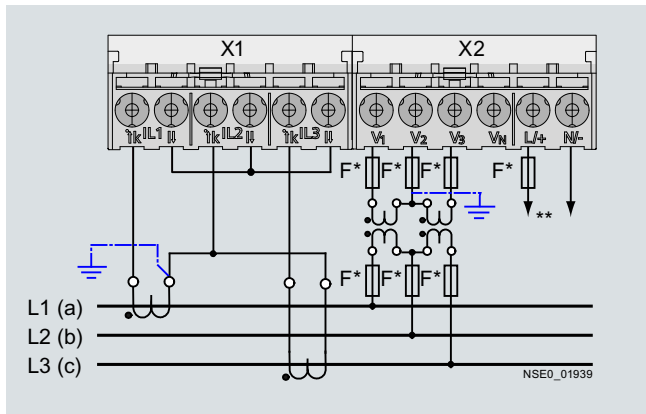

Connection example 11:

Two-phase measurement, three conductors, asymmetric load, without voltage transformer, with two current transformers

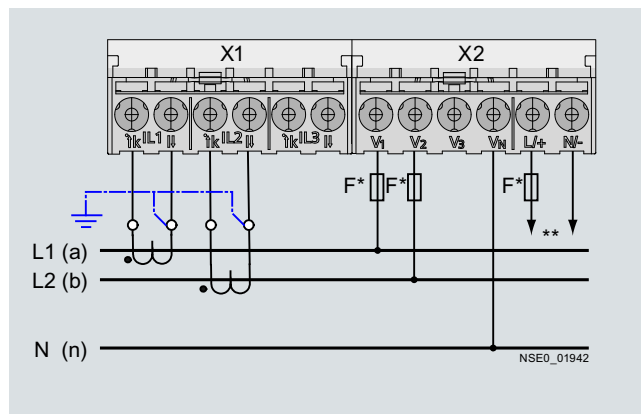

Connection example 9:

Three-phase measurement, three conductors, symmetric load, without voltage transformer, with one current transformer

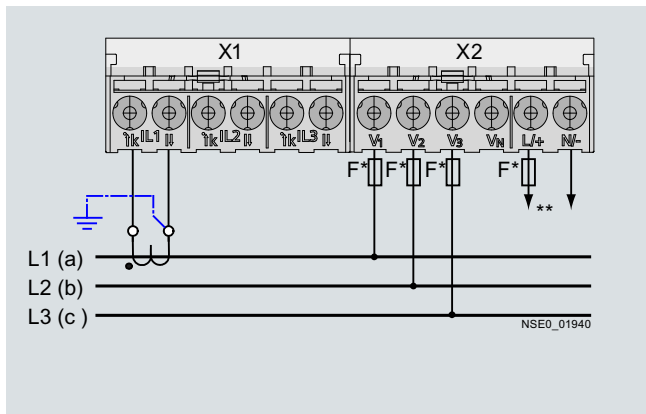

Connection example 12:

Single-phase measurement, two conductors, without voltage transformer, with one current transformer

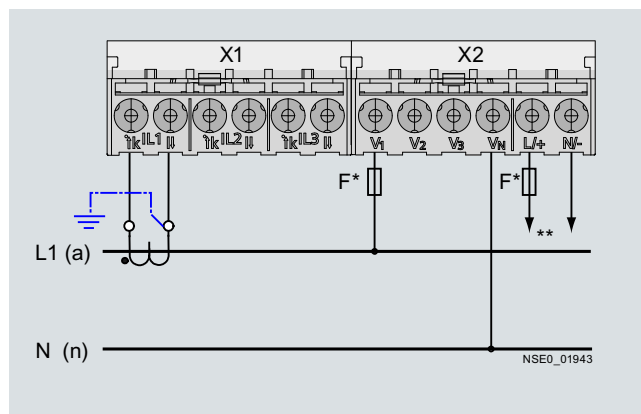

* Fuses must be provided by the user.

** Connection of the supply voltage.

13

SENTRON Multifunction Measuring Instruments

PAC3200 multifunction measuring instruments

Connection example 13:

Three-phase measurement, four conductors, asymmetric load, with voltage transformer, with three current transformers

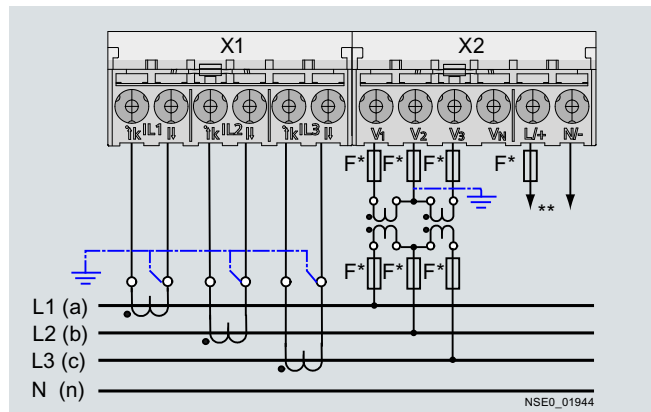

- * Fuses must be provided by the user.
- ** Connection of the supply voltage.

Protection of the supply voltage input:

Fuse holders	Cylindrical fuse links
3NW7-5130HG	3NW1006-0HG (0.6A)

Connection

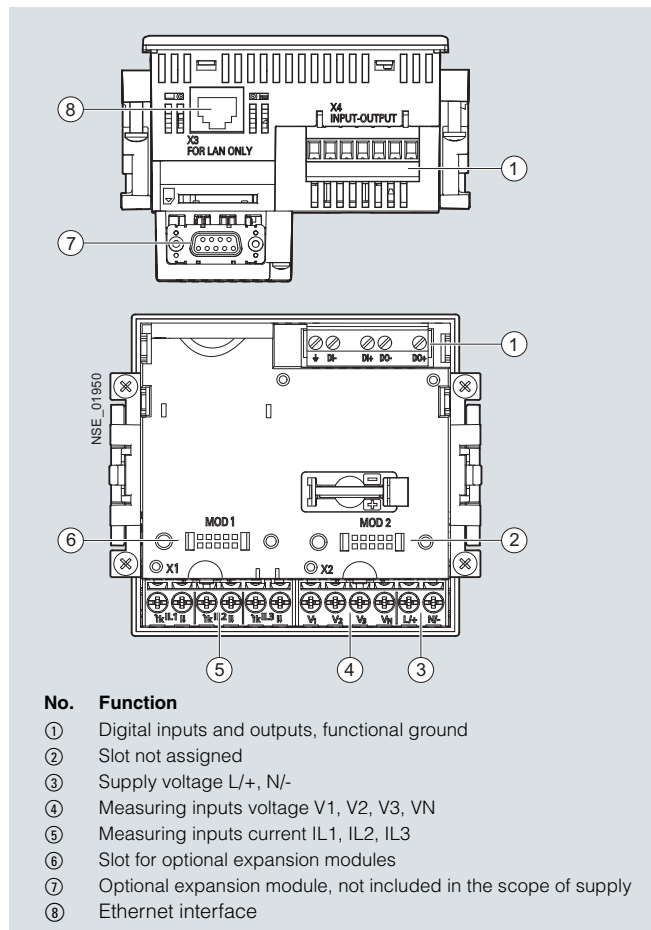

PAC3200 terminal assignment in overview

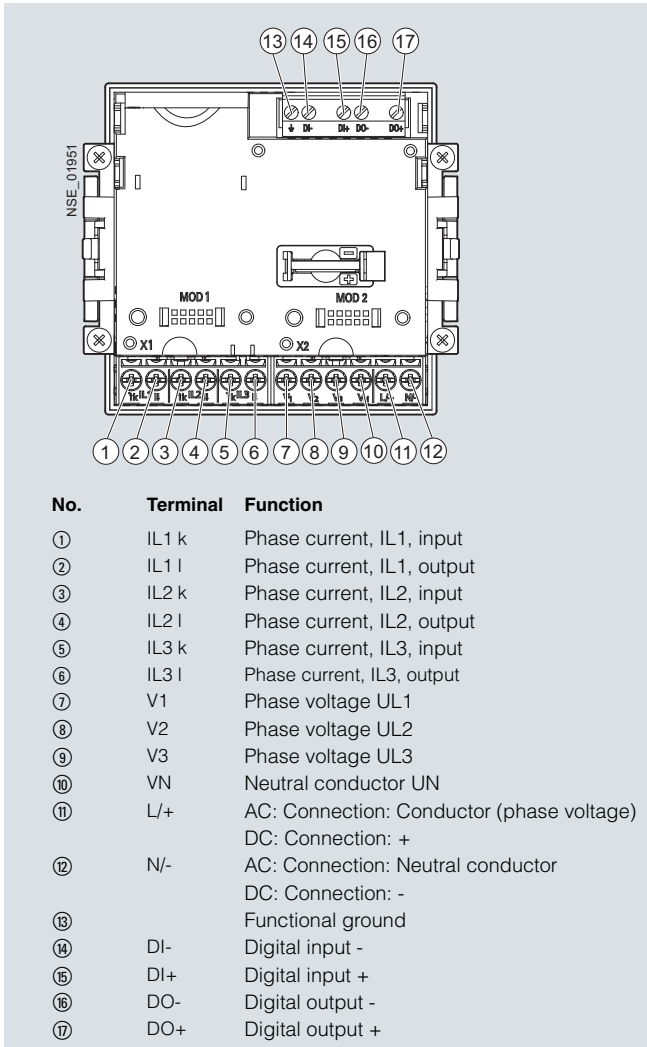

PAC3200 terminal assignment in detail

SETRON Multifunction Measuring Instruments

PAC PROFIBUS DP expansion modules

Technical specifications

Communication

PROFIBUS DP

Transmission rate max.	MBit/s	12
Protocol		PROFIBUS DPV1
Variables to be transmitted		Definable using GSD file

Dimensions and weights

Enclosure dimensions (W x H x D)

Module enclosure for plugging onto the PAC3200	mm	43 x 63 x 22
--	----	--------------

Weight approx.	g	45
----------------	---	----

Degree of protection

Degree of protection acc. to EN 60529		IP20
---------------------------------------	--	------

Ambient conditions

Temperature range

Operating temperature	°C	-10 ... + 55
Storage and transport temperature	°C	-25 ... + 70

Relative air humidity

At 25 °C without condensation	%	95
-------------------------------	---	----

Operating altitude

Above sea level up to max.	m	2000
----------------------------	---	------

Degree of pollution		2
---------------------	--	---

Dimensional drawings

Dimensions of PAC PROFIBUS DP expansion module at the side and from above

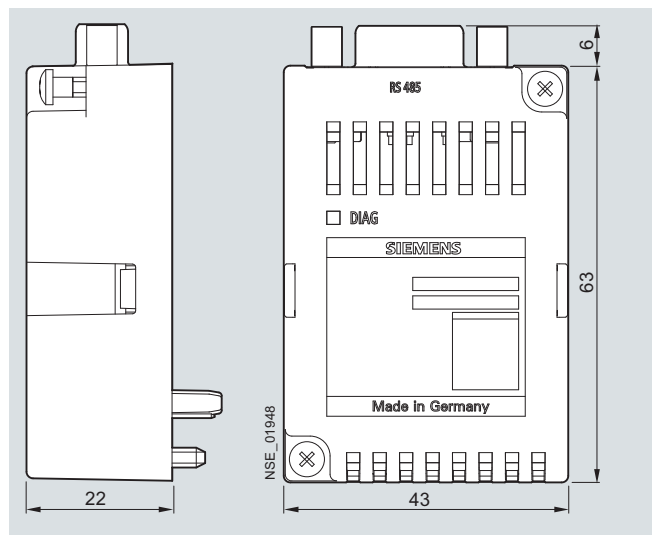

Dimensions of the plug connector between the PAC PROFIBUS DP expansion module and the PAC3200

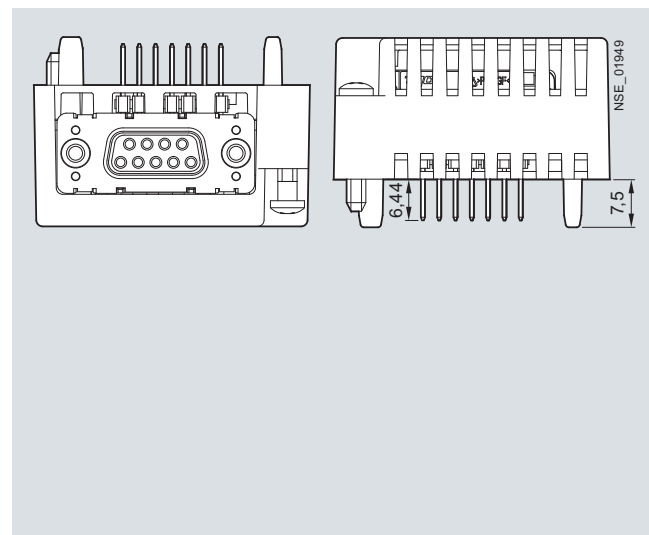

More information

More information can be found on the Internet at

<http://www.siemens.com/powermanagementsystem>

Technical specifications

Communication

RS485

Transmission rates	kBd	Optionally 4.8/9.6/19.2/38.4
Protocol		Optionally SEAbus or Modbus RTU (selectable)

Dimensions and weights

Enclosure dimensions (W x H x D)

Module enclosure for plugging onto the PAC3200	mm	43 x 63 x 22
--	----	--------------

Weight approx.	g	41
----------------	---	----

Degree of protection

Degree of protection acc. to EN 60529	IP20
---------------------------------------	------

Ambient conditions

Temperature range

Operating temperature	°C	-10 ... +55
Storage and transport temperature	°C	-25 ... +70

Relative air humidity

At 25 °C without condensation	%	95
-------------------------------	---	----

Operating altitude

Above sea level up to max.	m	2000
----------------------------	---	------

Degree of pollution	2
---------------------	---

Dimensional drawings

Dimensions of PAC RS485 expansion module at the side and from above

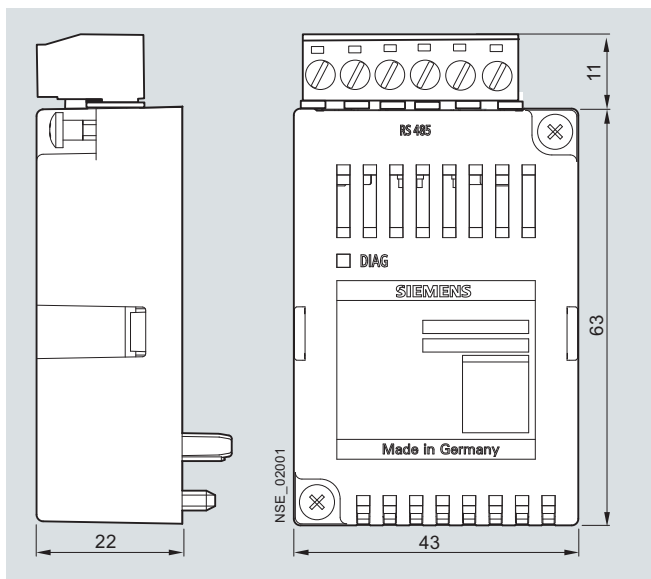

Dimensions of the plug connector between the PAC RS485 expansion module and the PAC3200

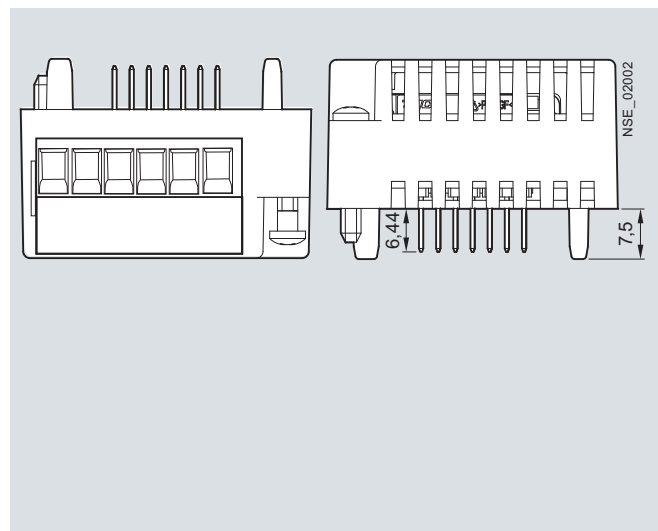

More information

More information can be found on the Internet at

<http://www.siemens.com/powermanagementsystem>

SENTRON Multifunction Measuring Instruments

Notes

13



SIVACON Power Distribution Boards, Busway Systems and Cubicle Systems



14/2

Introduction

Switchgear

S8, 8PV and 8PT Power Distribution Boards and Motor Control Centers

14/3

General data

S8 power distribution boards and motor control centers

14/4

- Overview

14/4

- Design

14/7

- Technical specifications

14/7

- More information

Introduction

Overview



S8 power distribution boards and motor control centers up to 7000 A

Numerous options, many different advantages, flexible

For all applications in infrastructure and the process industry

In circuit breaker design

In 3NJ4 in-line design, fixed-mounted

In 3NJ6 in-line design, plugged in

In fixed-mounted design (infrastructure)

In universal installation systems for the combination of:

- Withdrawable version
- Fixed-mounted version
- 3NJ6 in-line design, plugged in

Degree of protection up to IP55

Tested in compliance with IEC 60439-1 (IEC 61439-1/2)

Tested for resistance to internal arcing faults in compliance with IEC 61641



8PT power distribution boards and motor control centers up to 7400 A

Reliable, economical, flexible and communication-capable

For all applications in infrastructure and process industry

In circuit breaker design

In 3NJ4 in-line design, fixed-mounted

In 3NJ6 in-line design, plugged in

In fixed-mounted design

In plug-in design

In withdrawable design

Degree of protection up to IP54

Type-tested

Tested for resistance to internal arcing faults

Tested for resistance to earthquakes



8PV power distribution boards and motor control centers up to 6300 A

Reliable, economical, flexible and communication-capable

For all applications in infrastructure and process industry

In circuit breaker design

In fixed-mounted design

In 3NJ4 in-line design, fixed-mounted

In 3NJ6 in-line design, plugged in

In plug-in design

In withdrawable design

Degree of protection up to IP54

Type-tested

Tested for resistance to internal arcing faults

Tested for resistance to earthquakes



8MC, 8MF system cubicles

System cubicles for individual solutions including cubicle air-conditioning for optimum operating conditions

For a wide range of applications in tough environments and in laboratories, offices and medical practices

Flexible expansion levels and types of delivery

Coordinated logistical and delivery concepts

Degree of protection up to IP55

For heavy integrated equipment up to 1000 kg

System cubicles in EMC version

System cubicles in earthquake-proof version

In all RAL colors, including special colors

S8, 8PV and 8PT Power Distribution Boards and Motor Control Centers

General data

Overview

Low-voltage switchboards form the link between equipment (generators), transmission (cables, overhead lines) and transformation (transformers) of electrical energy on the one hand, and the loads, such as motors, solenoid valves, actuators and devices for heating, lighting and air conditioning on the other.

As the majority of applications are supplied with low voltage, the low-voltage switchboard is of special significance in both public supply systems and industrial plants.

Reliable power supplies depend on good availability, flexibility to allow for changes and process-related modifications, and high operating safety.

Power distribution in a low-voltage system usually takes place via a main switchboard (power center or main distribution board) and a number of sub-distribution boards or motor distribution boards, also known as motor control centers (MCC) (see [example opposite](#)).

The SIVACON low-voltage switchboards offer optimum solutions in low-voltage systems for all applications up to 7400 A. The SIVACON 8PV switchboards are manufactured by Siemens in Leipzig, and the SIVACON 8PT and SIVACON S8 switchboards by Siemens and our SIVACON Technology Partners near you.

The most important selection criteria are shown in the table below.

You can find more information on the Internet at:

<http://www.siemens.com/sivacon>

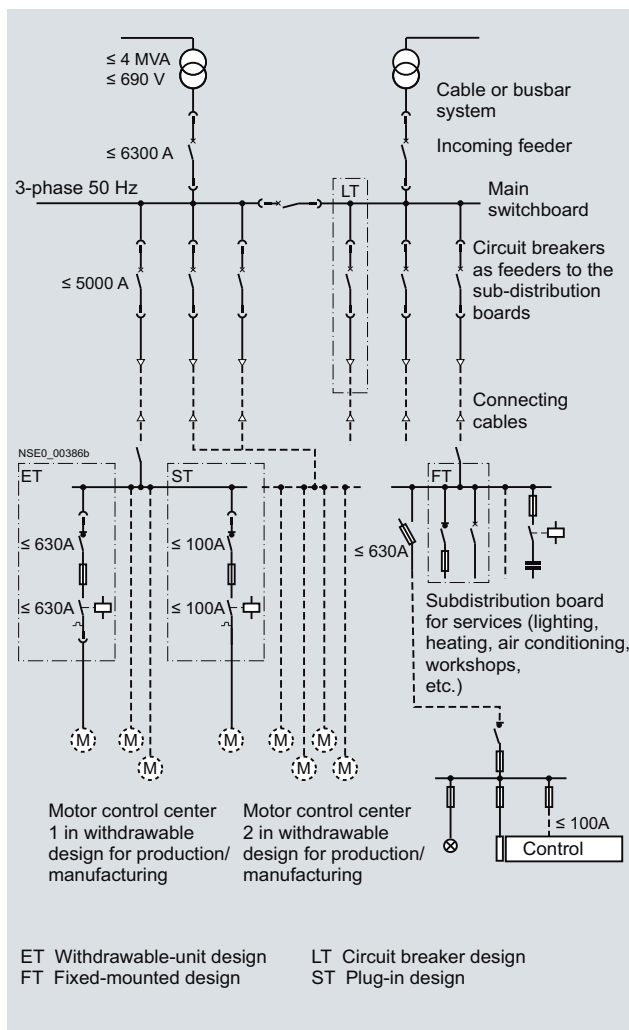

Selection criteria	SIVACON S8		SIVACON 8PV		SIVACON 8PT
	Top	Rear	Top	Rear	Top
Rated currents					
• Busbars up to	6300 A	7010 A	2500 A	6300 A	7400 A
• Infeed up to	6300 A	6300 A	2500 A	6300 A	6300 A
Short-circuit strength I_{pk} up to	330 kA	330 kA	110 kA	220 kA (250 kA)	375 kA
Equipment layout					
• Fixed-mounted version	✓ ¹⁾	✓ ¹⁾	✓	✓	✓
• 3NJ4 in-line design, fixed installation	✓	✓	✓	✓	✓
• 3NJ6 in-line design, plugged in	✓	✓	✓	✓	✓
• Plug-in design	--	--	✓	✓	✓
• Withdrawable version	✓	✓	✓	✓	✓
• Universal installation system	✓	✓	--	--	--
Type of installation					
• Free-standing/against wall	✓	✓	✓	✓	✓
• Back to back	✓	✓	✓	✓	✓
• Double-fronted	--	✓	--	✓	--
Use					
• Motor control center	✓	✓	✓	✓	✓
• Power distribution board	✓	✓	✓	✓	✓
Manufactured by SIVACON Technology Partner	✓	✓	--	--	✓

✓ Available

-- Not available

¹⁾ Circuit breakers optionally in withdrawable version.

Switchgear

S8, 8PV and 8PT Power Distribution Boards and Motor Control Centers

S8 power distribution boards and motor control centers

Overview



SIVACON S8 low-voltage switchgear and controlgear

Maximum safety and attractive design are combined in an efficient solution: with SIVACON S8, the new generation of switchboards for consistent and easy power distribution in non-residential and industrial buildings as well as in the process industry up to 7000 A.

The new design of the control cabinets opens up new applications, e.g. here as a motor control center. Following features are offered to improve personal and machine safety:

- Uniform operation for all withdrawable unit sizes
- Integrated operating error protection for all withdrawable units
- Unambiguous indication of withdrawable unit positions
- Separate actuation for main control switch and withdrawable unit position
- Test and disconnected position with door closed, without interruption of degree of protection
- Lockable disconnected position
- Optional withdrawable unit coding prevents swapping of withdrawable units of same size
- Swiveling instrument carrier on standard withdrawable units for making settings during operation
- Small withdrawable units for motor and cable feeders up to 63 A

The SIVACON S8 low-voltage switchboard is custom configured and constructed using type-tested functional components.

We or our authorized contractual partners take care of the following:

- Customized configuration
- Mechanical and electrical construction
- Inspection

Documentation prescribed by us serves as the basis for our authorized contractual partners.

Standards and specifications

The SIVACON S8 switchboard is a type-tested low-voltage switchgear and controlgear assembly (TTA) according to IEC 60439-1, EN 60439-1. The switchboard is designed to be resistant to arcing faults according to IEC 61641, EN 60439 supplement sheet 2.

SIVACON S8 can be used as a type-tested power distribution board and motor control center up to 7000 A.

You can find more information on the Internet at:

<http://www.siemens.com/sivacon>

Design

Equipment layouts

The SIVACON S8 low-voltage switchboard consists of standardized and typified components which can be flexibly combined as a cost-effective overall solution.

The following equipment layouts according to the diagram below are available:

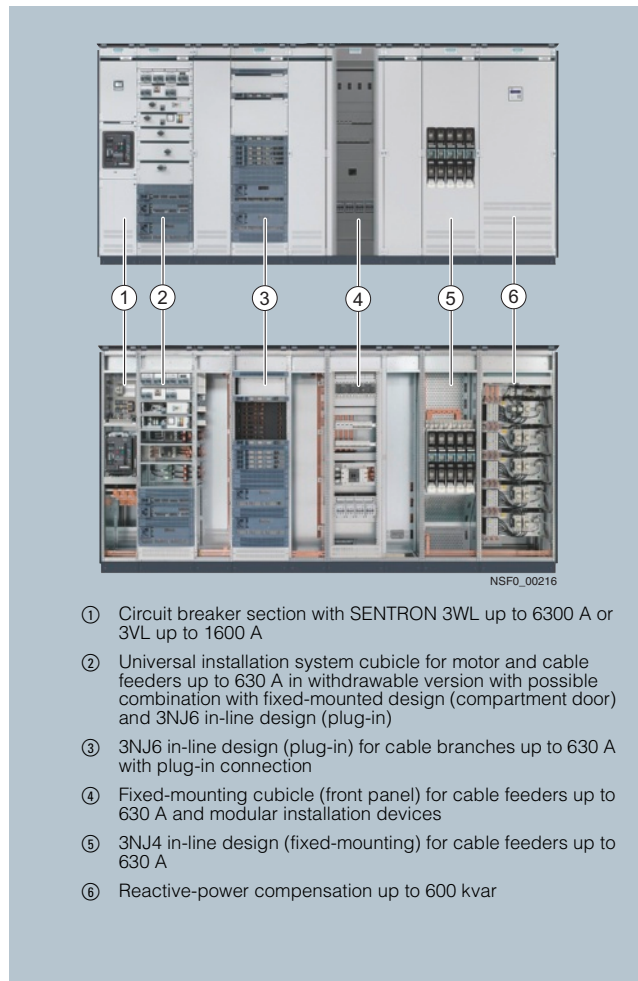

- ① Circuit breaker section with SENTRON 3WL up to 6300 A or 3VL up to 1600 A
- ② Universal installation system cubicle for motor and cable feeders up to 630 A in withdrawable version with possible combination with fixed-mounted design (compartment door) and 3NJ6 in-line design (plug-in)
- ③ 3NJ6 in-line design (plug-in) for cable branches up to 630 A with plug-in connection
- ④ Fixed-mounting cubicle (front panel) for cable feeders up to 630 A and modular installation devices
- ⑤ 3NJ4 in-line design (fixed-mounting) for cable feeders up to 630 A
- ⑥ Reactive-power compensation up to 600 kvar

S8, 8PV and 8PT Power Distribution Boards and Motor Control Centers

S8 power distribution boards
and motor control centers**Re (1): circuit breaker design**

The fields for the installation of 3WL and 3VL circuit breakers are used to feed the switchgear and for outgoing units and busbar couplings (longitudinal and cross coupling). It is important for the entire circuit breaker design that only one switch per field is used.



The device installation space is intended for the following functions:

- Infeeds/outgoing units with 3WL circuit breaker in fixed-mounted and withdrawable version up to 4000 A
- Longitudinal and cross coupling with 3WL circuit breaker in fixed-mounted and withdrawable version up to 4000 A
- Infeeds/outgoing units with 3VL circuit breaker in fixed-mounted version up to 1600 A

Re (2): universal installation system

Universal installation system fields are fields for cable and motor feeders in withdrawable, fixed-mounted and plug-in design up to 630 A or 250 kW. With their combination options they offer high efficiency and flexibility and are intended for the installation of the following controls:

- SIRIUS 3RV motor starter protector/3VL circuit breaker
- SENTRON 3K switch disconnecter
- SENTRON 3NP switch disconnecter
- SENTRON 3NJ6 switch disconnecter in plug-in version



The controlgears and controlgear assemblies are constructed as cable feeders in fixed-mounted design or as cable and motor feeders in withdrawable design. It is possible to install plug-in 3NJ6 in-line switch disconnectors using an adapter.

Re (3): 3NJ6 in-line version plugged in

The fields for cable feeders in plug-in version up to 630 A are intended for the installation of switch disconnectors in in-line disconnector design. They offer an affordable alternative to the withdrawable version with the supply-line side plug-in contact. Due to their modular structure, they allow quick and easy retrofitting or replacement under operating conditions.



The device installation space is calculated to accommodate plug-in in-line switch disconnectors with a pole center-to-center clearance of 185 mm.

The plug-in busbar system is arranged in the field in the back and is covered with optional touch protection with tap openings in degree of protection IP 20. Replacement of the in-line switch disconnectors without shutting down the switchgear is thus possible.

Re (4): fixed-mounted version with front panels

In the fields for cable feeders in fixed-mounted design, the controlgears are mounted on steplessly adjustable device holders and connected to the vertical distribution busbars with the in-feed side. These fields are intended for the installation of the following switchgears up to 630 A:

- SIRIUS 3RV motor starter protector/3VL circuit breaker
- SENTRON 3K switch disconnecter
- SENTRON 3NP switch disconnecter
- Modular installation devices



To the front the fields for cable feeders in fixed-mounted version are covered by masking frames with and without swivel function. They can also be covered by additional doors with or without a window.

Switchgear

S8, 8PV and 8PT Power Distribution Boards and Motor Control Centers

S8 power distribution boards and motor control centers

Re (5): in-line design 3NJ4 (fixed installation)

The fields for cable feeders in fixed-mounted versions up to 630 A are intended for the installation of 3NJ4 in-line fuse switch disconnectors.

With their compact design and modular structure, the in-line fuse switch disconnectors provide the optimum installation conditions in terms of the achievable packing density.



The field busbar system is arranged horizontally in the field. The field busbar system is connected to the main busbar system with link rails.

The in-line fuse switch disconnectors are screwed directly onto the field busbar system.

Re (6): reactive-power compensation up to 600 kvar

The reactive power compensation fields consist of a controller module and one or more capacitor modules.



Choked or unchoked controller units are available for reactive-power compensation depending on the consumer type. Depending on the installed output and the ambient temperature, the installation of a floor fan can be necessary to reinforce the convection.

The capacitor modules are connected together and connected to the horizontal main busbar system via the link rails. The capacitor modules are mounted on the fuse switch disconnectors.

Installation of capacitor modules:

- Unchoked up to 600 kvar per field
- Choked up to 500 kvar per field

It is also possible to install a group switch module in order to enable the field for maintenance and review purposes from the main busbar system.

S8, 8PV and 8PT Power Distribution Boards and Motor Control Centers

S8 power distribution boards
and motor control centers

Technical specifications

Standards and specifications			
Type-tested low-voltage switchgear and controlgear assemblies (TTA)		IEC 60439-1, EN 60439-1 (VDE 0660 Part 500)	
Inspection of behavior with internal errors (arcing faults)		IEC 61641 (VDE 0660 Part 500), supplement sheet 2	
Protection against electric shock		EN 50274 (VDE 0660 Part 514)	
Rated insulation voltage (U_i), main circuit	V	Up to 1000	
Rated operational voltage (U_o), main circuit	V	Up to 690	
Clearances in air and creepage distances			
Rated impulse withstand voltage (U_{imp})	kV	8	
Overtoltage category		III	
Degree of pollution		3	
Busbars (3-pole and 4-pole)			
Horizontal main busbars	Rated current	A	Up to 7000
	Rated surge current withstand capability (I_{pk})	kA	Up to 330
	Rated short-time withstand current (I_{cw})	kA	Up to 150
Vertical busbars	Rated current	A	Up to 6300
	Rated surge current withstand capability (I_{pk})	kA	Up to 220
	Rated short-time withstand current (I_{cw})	kA	Up to 100
• For circuit breaker design	Rated current	A	Up to 1600
	Rated surge current withstand capability (I_{pk})	kA	Up to 143
	Rated short-time withstand current (I_{cw})	kA	Up to 65 ¹⁾
• For universal and fixed-mounted version	Rated current	A	Up to 1600
	Rated surge current withstand capability (I_{pk})	kA	Up to 143
	Rated short-time withstand current (I_{cw})	kA	Up to 65 ¹⁾
• For in-line design 3NJ4 (fixed installation)	Rated current	A	Up to 1600
	Rated conditional short-circuit current (I_{cc})	kA	Up to 50
• For in-line design 3NJ6 (plug-in)	Rated current	A	Up to 2100
	Rated surge current withstand capability (I_{pk})	kA	Up to 110
	Rated short-time withstand current (I_{cw})	kA	Up to 50 ¹⁾
Device rated currents			
3WL/3VL circuit breaker	A	Up to 6300	
Cable feeders	A	Up to 630	
Rated motor power			
Motor outgoing feeders	kW	Up to 250	
Internal separation (Form 1 to Form 4)			
		IEC 60439-1, 7.7 (VDE 0660 part 500, 7.7)	
Surface treatment (coating acc. to DIN 43656)			
Frame parts, bases		Sendzimir-galvanized	
Doors		Powder-coated	
Side panels		Powder-coated	
Back panels, roof plates		Sendzimir-galvanized	
Ventilation roof		Powder-coated	
Standard color of the powder-coated parts (coating thickness 100±25 µm)		RAL 7035, light gray Design parts: Blue Green Basic	
Degree of protection (acc. to IEC 60529, EN 60529)			
		IP30, IP31, IP40, IP41, IP54	
Dimensions (preferential dimensions acc. to DIN 41488)			
Height (without base)	mm	2000, 2200	
Width	mm	400, 600, 800, 1000, 1200	
Depth	Single-fronted	mm	500, 600, 800
	Double-fronted	mm	1000, 1200

1) Rated conditional short-circuit current (I_{cc}) = 100 kA.

More information

You can find more information on the Internet at:

<http://www.siemens.com/sivacon>

Switchgear

S8, 8PV and 8PT Power Distribution Boards and Motor Control Centers

Notes

SENTRON Switching and Protection Devices – Air Circuit Breakers

15



15/2

Introduction

3WL Air Circuit Breakers

3WL Air Circuit Breakers/
Non-Automatic Air Circuit Breakers
up to 6300 A (AC)

General data

- 15/6 - Design
- 15/12 - Function
- 15/19 - Configuration
- 15/24 - Technical specifications

Project planning aids

- 15/32 - Characteristic curves
- 15/34 - Dimensional drawings
- 15/47 - Schematics
- 15/49 - More information

3WL Non-Automatic Air
Circuit Breakers up to 4000 A (DC)

General data

- 15/50 - Technical specifications
- Project planning aids
- 15/51 - Characteristic curves
 - 15/51 - Dimensional drawings
 - 15/55 - Schematics
 - 15/56 - More information

Introduction

Overview



Size I



Size II



Size III

Air circuit breakers

3WL air circuit breakers/non-automatic air circuit breakers up to 6300 A (AC)

Size	I, II, III
Rated current I_n	A 630, 800, 1000, 1250, 1600, 2000, 2500, 3200, 4000, 5000, 6300

Number of poles 3-pole, 4-pole

Rated operational voltage U_e	V AC	V DC
	Up to 690/1000/1150	--

Rated ultimate short-circuit breaking capacity at 500 V AC	kA	Size I	Size II	Size III
		55/66	66/80/100	100/150 (3-pole), 130 (4-pole)

Endurance	Operating cycles	20000	15000	10000

Mounting position

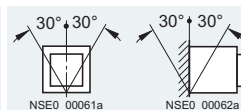
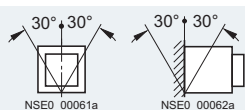

Degree of protection

With cover
Without cover
(with door sealing frame)

IP55
IP41

IP55
IP41

Dimensions 3-/4-pole

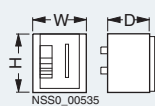

Fixed mounting

Withdrawable

	W mm	320/410	460/590	704/914	460/590
H mm		434	434	434	434
D mm		291	291	291	291
H mm		465,5	465,5	465,5	465,5
D mm		471	471	471	471

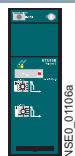

Type	ETU15B ¹⁾	ETU25B	ETU27B	ETU45B	ETU76B
------	----------------------	--------	--------	--------	--------

Solid-state releases for SENTRON 3WL circuit breakers

Overload protection	✓	✓	✓	✓	✓
Short-time delayed short-circuit protection	--	✓	✓	✓	✓
Instantaneous short-circuit protection	✓	✓	✓	✓	✓
Neutral conductor protection	--	--	✓	✓	✓
Ground-fault protection	--	--	✓	□	□
Zone Selective Interlocking	--	--	--	□	□
LCD, 4-line	--	--	--	□	--
LCD, graphic	--	--	--	--	✓
Communication through PROFIBUS DP/MODBUS	--	--	--	□	□
Measurement function Plus	--	--	--	□	□
Selectable parameter sets	--	--	--	--	✓
Parameters freely programmable	--	--	--	--	✓
CubicleBUS	--	--	--	✓	✓

- ✓ Standard
- Not available
- Optional

¹⁾ ETU15B cannot be used with 3WL circuit breakers, size III.

3WL air circuit breakers/non-automatic air circuit breakers according to UL 489 up to 5000 A, see Catalog LV 16.

Switching capacity

Size	I				II				III							
Type	3WL11				3WL12				3WL13							
Switching capacity class	N	\textcircled{N}	S	\textcircled{S}	N	\textcircled{N}	S	\textcircled{S}	H	\textcircled{H}	H	\textcircled{H}	C 3-pole	\textcircled{C}	C 4-pole	\textcircled{C}
Short-circuit breaking capacity																
Rated operational voltage U_e up to 415 V AC																
I_{cu}	kA	55	66	66	66	80	100	100	100	100	100	150	150	130	130	
I_{cs}	kA	55	66	66	66	80	100	100	100	100	100	150	150	130	130	
I_{cm}	kA	121	145	145	145	176	220	220	220	220	220	330	330	286	286	
Rated operational voltage U_e up to 500 V AC																
I_{cu}	kA	55	66	66	66	80	100	100	100	100	100	150	150	130	130	
I_{cs}	kA	55	66	66	66	80	100	100	100	100	100	150	150	130	130	
I_{cm}	kA	121	145	145	145	176	220	220	220	220	220	330	330	286	286	
Rated operational voltage U_e up to 690 V AC																
I_{cu}	kA	42	50	50	50	75	85	85	85	85	85	150	150	130	130	
I_{cs}	kA	42	50	50	50	75	85	85	85	85	85	150	150	130	130	
I_{cm}	kA	88	105	105	105	165	187	187	187	187	187	330	330	286	286	
Rated operational voltage U_e up to 1000 V/1150 V AC																
I_{cu}	kA	--	--	--	--	--	45	50	50	50	50	70 ⁴⁾	70 ⁴⁾	70 ⁴⁾	70 ⁴⁾	
I_{cs}	kA	--	--	--	--	--	45	50	50	50	50	70 ⁴⁾	70 ⁴⁾	70 ⁴⁾	70 ⁴⁾	
I_{cm}	kA	--	--	--	--	--	95	105	105	105	105	154 ⁴⁾	154 ⁴⁾	154 ⁴⁾	154 ⁴⁾	
Rated short-time withstand current I_{cw} of the circuit breakers³⁾																
0.5 s	kA	50	66	66	66	80	100	100	100	100	100	100	100	100	100	
1 s	kA	42	50	55	55	66	80	80	80	80	80	100	100	100	100	
2 s	kA	29.5	35	39	39	46	65 ^{1)/70²⁾}	65 ^{1)/70²⁾}	65 ^{1)/70²⁾}	65 ^{1)/70²⁾}	65 ^{1)/70²⁾}	80	80	80	80	
3 s	kA	24	29	32	32	37	50 ^{1)/65²⁾}	50 ^{1)/65²⁾}	50 ^{1)/65²⁾}	50 ^{1)/65²⁾}	50 ^{1)/65²⁾}	65	65	65	65	
Short-circuit breaking capacity I_{cc} of the non-automatic air circuit breakers																
Up to 500 V AC	kA	50	66	66	66	80	100	100	100	100	100	100	100	100	100	
Up to 690 V AC	kA	42	50	50	50	75	85	85	85	85	85	100	100	100	100	

\textcircled{N} Circuit breakers with ECO switching capacity N ($I_{cu} = I_{cs}$ up to 55 kA size I/up to 66 kA size II at 500 V)

\textcircled{S} Circuit breakers with standard switching capacity S ($I_{cu} = I_{cs}$ up to 66 kA size I/up to 80 kA size II at 500 V)

\textcircled{H} Circuit breakers with high switching capacity H ($I_{cu} = I_{cs}$ up to 100 kA at 500 V)

\textcircled{C} Circuit breakers with very high switching capacity C ($I_{cu} = I_{cs}$ up to 150 kA (3-pole)/130 kA (4-pole) at 500 V)

\textcircled{DC} Circuit breakers with DC switching capacity

These circuit breakers are indicated in the Technical specifications by orange backgrounds.

1) Size II with $I_{n \max} \leq 2500$ A.

2) Size II with $I_{n \max} = 3200$ A and $I_{n \max} = 4000$ A.

3) At a rated voltage of 690 V the I_{cw} value of the circuit breaker cannot be greater than the I_{cu} or I_{cs} value at 690 V.

4) Rated operational voltage $U_e = 1150$ V.

SENTRON Switching and Protection Devices – Air Circuit Breakers

Introduction

SENTRON 3WL:
Superior individual products integrated into uniform power distribution systems – up to and including industry-specific industrial and infrastructure solutions

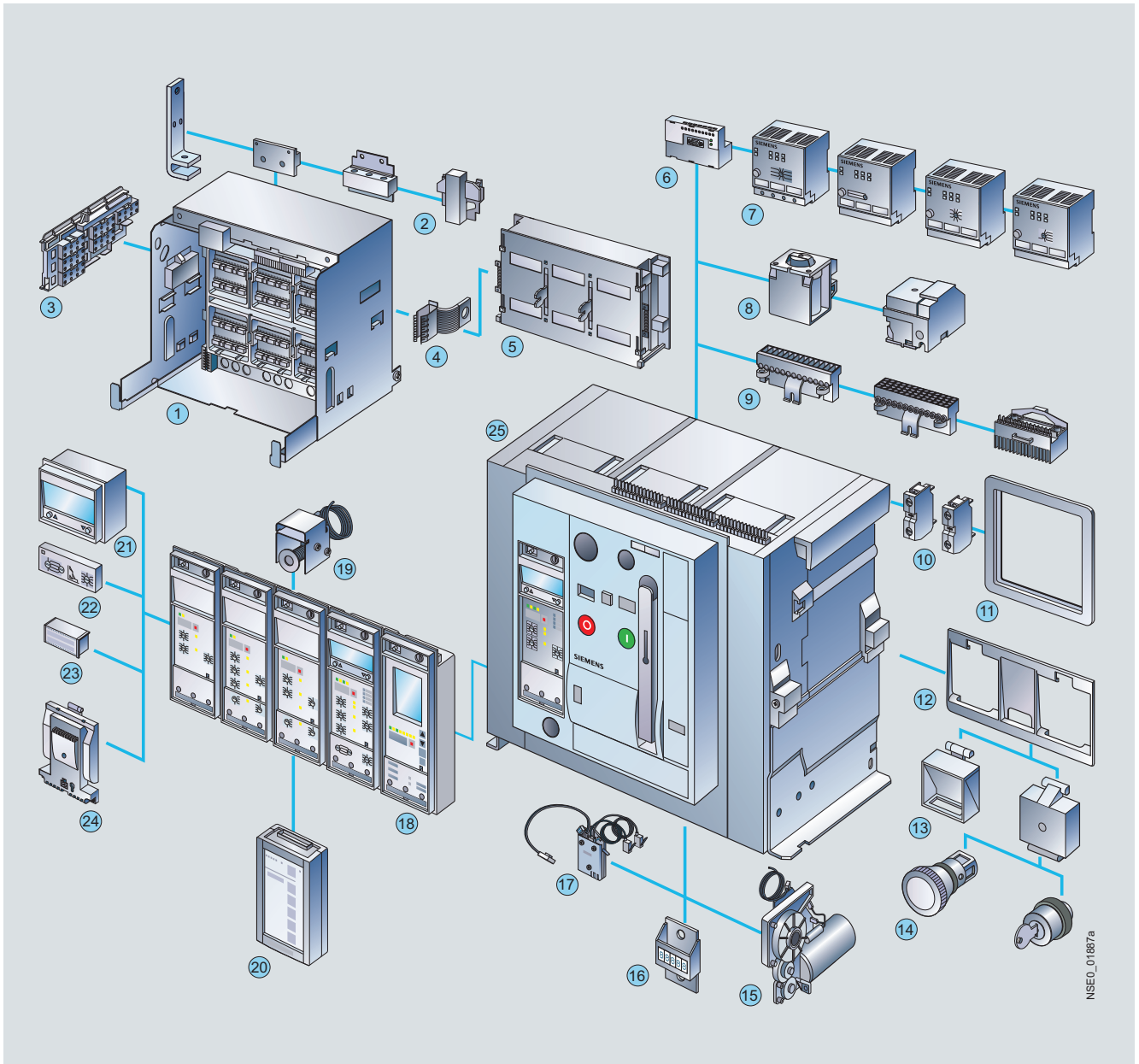

- | | |
|--|---|
| ① Guide frame | ⑬ Transparent panel, function insert |
| ② Main circuit connection, front, flange, horizontal, vertical | ⑭ EMERGENCY-STOP pushbutton, key operated |
| ③ Position indicator switch | ⑮ Motorized operating mechanism |
| ④ Grounding contact, leading | ⑯ Operating cycles counter |
| ⑤ Shutter | ⑰ Breaker Status Sensor (BSS) |
| ⑥ COM15 PROFIBUS module or COM16 MODBUS module | ⑱ Protective devices with device holder, solid-state releases (ETU) |
| ⑦ External Cubicle BUS modules | ⑲ Remote reset solenoid |
| ⑧ Closing solenoid, auxiliary release | ⑳ Breaker Data Adapter (BDA) |
| ⑨ Auxiliary conductor plug-in system | ㉑ Four-line display |
| ⑩ Auxiliary switch block | ㉒ Ground-fault protection module |
| ⑪ Door sealing frame | ㉓ Rated current module |
| ⑫ Interlocking set for base plate | ㉔ Measuring function module |
| ⑬ Transparent panel, function insert | ㉕ Circuit breaker |
| ⑭ EMERGENCY-STOP pushbutton, key operated | |
| ⑮ Motorized operating mechanism | |

NSEO_01887a

Communication-capable circuit breakers (with ETU45B or ETU76B solid-state release)

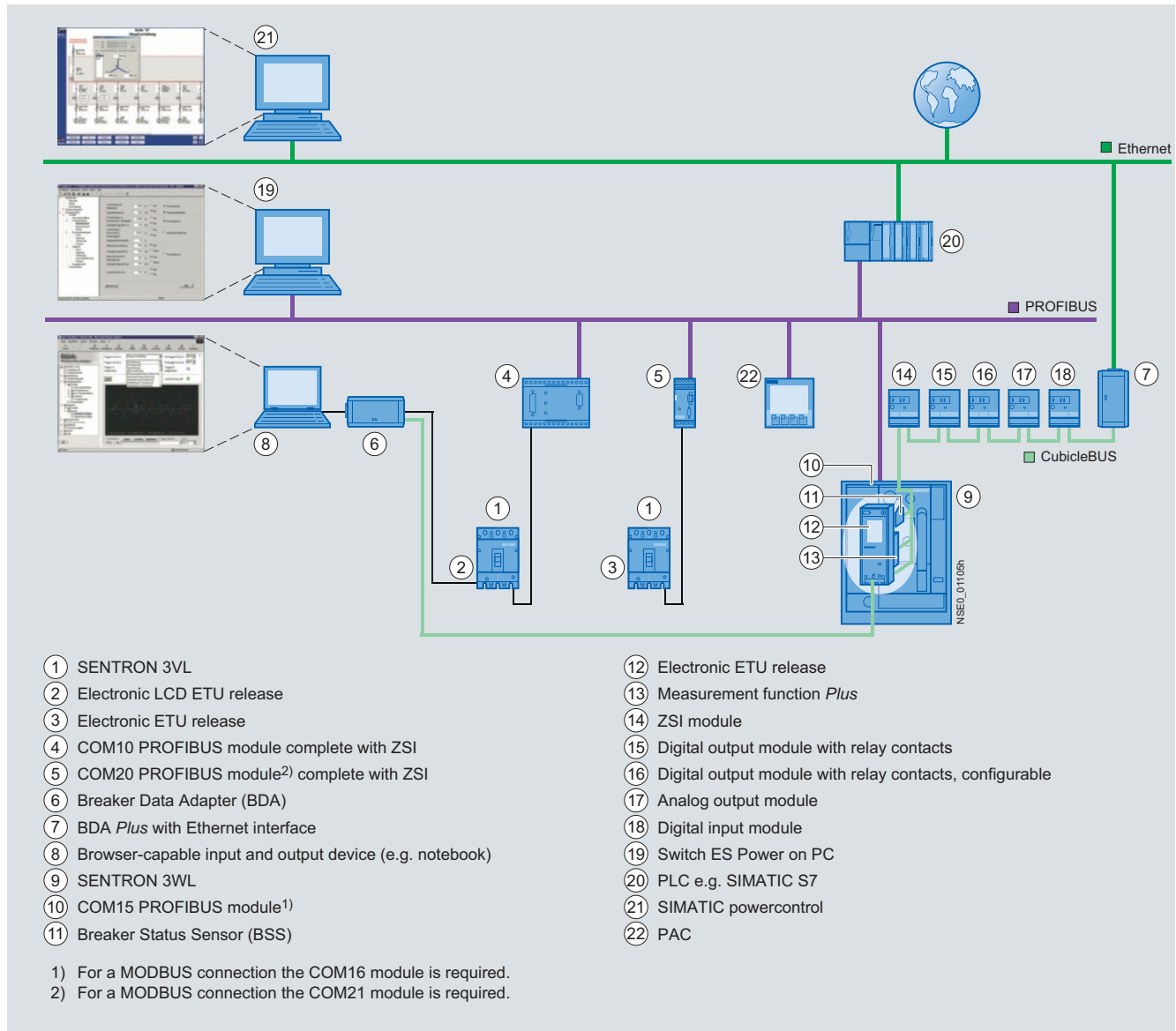

Features

- Coordinated communication concept using the PROFIBUS DP or MODBUS, ranging from 16 A to 6300 A with SENTRON 3VL and SENTRON 3WL
- The high level of modularity of circuit breakers and accessories allows easy retrofitting of all communication components
- Significant additional benefits for the switchboard due to the possibility of linking up external input and output modules to the circuit breaker-internal **CubicleBUS** of the SENTRON 3WL
- Innovative software products for parameterization, operation, monitoring, and diagnostics of SENTRON circuit breakers, both locally or via PROFIBUS DP, MODBUS or Ethernet/ Intranet/Internet
- Complete integration of the SENTRON circuit breakers into the Totally Integrated Power and Totally Integrated Automation solutions

Communication:



- For air circuit breakers with optional communication function (ETU45B or ETU76B solid-state release) see Catalog LV 1.
- For accessories see Catalog LV 1.
- For more information see also the Chapter "Power Management System" and "Software for Power Distribution".

3WL Air Circuit Breakers

3WL Air Circuit Breakers/Non-Automatic Air Circuit Breakers up to 6300 A (AC)

General data

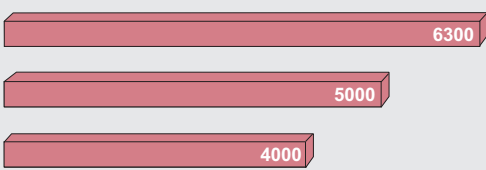
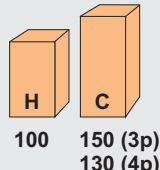
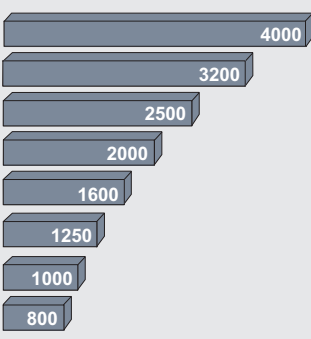
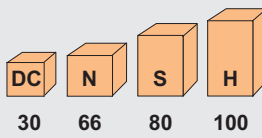
Design

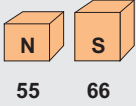
	Circuit breaker rated current $I_{n\max}$ (A)	Breaking capacity I_{cu} at 500 V AC (kA) or I_{cc} at 300 V DC (kA)	Dimensions			
			Fixed-mounted, 3- /4-pole	With- drawable 3- /4-pole		
Size III			704 / 914	704 / 914	Width	
			434 / 434	460 / 460	Height	
			291 / 291	385 / 385	Depth	
Size II			460 / 590	460 / 590	Width	
			434 / 434	460 / 460	Height	
			291 / 291	385 / 385	Depth	
Size I			320 / 410	320 / 410	Width	
			434 / 434	460 / 460	Height	
			291 / 291	385 / 385	Depth	

The dimension for the depth of the circuit breaker is from the circuit breaker rear to the inner surface of the closed switchgear door.

NSEO_00887

Overview of SENTRON 3WL circuit breakers/
non-automatic air circuit breakers

Versions

- Rated currents: 630 A to 6300 A
- 3 sizes for different rated current ranges (see illustration "Overview of SENTRON 3WL Circuit Breakers/Non-Automatic Circuit Breakers")
- 3- and 4-pole versions
- Rated operational voltage up to 690 V AC and 1000 V DC. Special versions up to 1000 V AC and 1150 V AC available
- 4 different switching capacity classes in the range from 55 kA to 150 kA for AC applications and one switching capacity class for DC applications.

The SENTRON 3WL circuit breakers are supplied complete with operating mechanism (manual operating mechanism with mechanical closing), solid-state release and auxiliary switches (2 NO contacts + 2 NC contacts in the standard version), and can be equipped with auxiliary releases.

Installation types

Fixed-mounted or withdrawable version

Ambient temperatures

The SENTRON 3WL circuit breakers are climate-proof according to IEC 60068-2-30. They are intended for use in enclosed areas where no severe operating conditions (e. g. dust, corrosive vapors, damaging gases) are present.

When installed in dusty and damp areas, suitable enclosures must be provided.

Coordinated dimensions

The dimensions of SENTRON 3WL circuit breakers only differ in terms of the width of the device which depends on the number of poles and the size.

Due to the nature of the design, the dimensions of devices with a withdrawable version are determined by the dimensions of the guide frames, which are slightly larger.

Non-automatic air circuit breakers

A special version of circuit breaker is utilized as a non-automatic air circuit breaker. The non-automatic air circuit breakers are designed without an solid-state release system and do not perform any protection duties for the system.

One potential application is the use as a bus coupler in systems with parallel feed-ins.

The versions and features can be selected according to those of the circuit breakers.

Operating mechanisms

The circuit breakers are available with various optional operating mechanisms:

- Manual operating mechanism with mechanical closing (standard design)
- Manual operating mechanism with mechanical and electrical closing
- Motorized operating mechanism with mechanical and electrical closing

The operating mechanisms with electrical closing can be used for synchronization tasks.

3WL Air Circuit Breakers/Non-Automatic Air Circuit Breakers up to 6300 A (AC)

General data

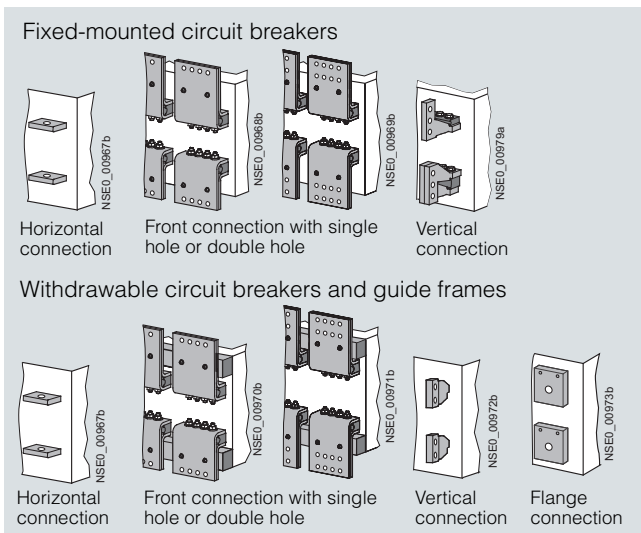

Main circuit connections – connection types

Main circuit connections

All circuit breakers are equipped with horizontal main circuit connections on the rear for up to 5000 A as standard (horizontal connection to busbars). Exception: Circuit breakers of size II with max. rated current 4000 A.

Circuit breakers with a max. rated current of 6300 A and circuit breakers size II with a max. rated current of 4000 A are equipped with vertical main connections (for upright busbars).

The following options are available, with all combinations of top and bottom connections possible:

- Accessible from the front, single hole (for vertically installed busbars)
- Accessible from the front, double hole (holes according to DIN 43673) (for vertically installed busbars)
- At the rear, vertical (for vertically installed busbars)
- Connecting flange (for direct connection to guide frame up to 4000 A).

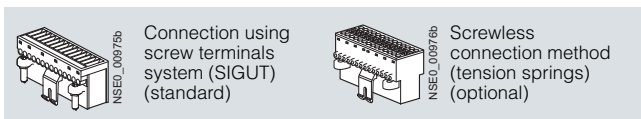

Connection options for auxiliary circuit connections

Auxiliary circuit connections

The type of connection for the auxiliary switches depends on the type of installation:

- **Withdrawable version:** The internal auxiliary switches are connected to the male connector on the switch side. When fully inserted, the connector makes a connection with the sliding contact module (see "Design", graphic "Guide Frame") in the guide frame. Various adapters can then be used to complete the wiring (see the graphic "Connection Options for Auxiliary Circuit Connections").
- **Fixed mounting:** In this case the auxiliary supply connectors are engaged directly onto the circuit breaker. The connectors are equipped with coding pins that prevent them being mistakenly interchanged.

Operator panel

The operator panel is designed to protrude from a cut-out in the door providing access to all control elements and displays with the control cabinet door closed.

The operator panels for all circuit breakers (fixed-mounted/withdrawable versions, 3-/4-pole) are identical. The operator panel ensures degree of protection IP41.

Safety and reliability

To protect the circuit breakers and plant against unauthorized switching as well as the maintenance and operator personnel, the system contains many locking devices. Others can be retrofitted.

Other safety features include:

- Infeed from above or below, as required
- Locking of the guide frame with the circuit breaker removed, as standard
- Locking of the withdrawable circuit breaker against movement, as standard
- High degree of protection with cover IP55
- Mechanical reclosing lockout after overload or short-circuit release as standard
- The circuit breaker is always equipped with the required number of auxiliary supply connectors

Standard version

SETRON 3WL circuit breakers are equipped with the following features as standard:

- Mechanical ON and OFF pushbutton
- Manual operating mechanism with mechanical closing
- Switch position indicator
- Ready-to-close indicator
- Memory status indicator
- Auxiliary switch 2 NO + 2 NC
- Rear horizontal main circuit connections for fixed-mounted and withdrawable versions up to 5000 A, and rear vertical main circuit connections for 6300 A applications and size II with 4000 A
- For 4-pole circuit breakers, the fourth pole (N) is installed on the left and is 100 % loadable with the rated current
- Contact erosion indicator for the main contacts
- Auxiliary circuit plug-in system with SIGUT screw terminals Delivery inclusive of all auxiliary circuit connectors to internal features including coding device for the prevention of incorrect installation of auxiliary supply connectors for fixed-mounted circuit breakers
- Mechanical "tripped" indicator for solid-state release system
- Mechanical reclosing lockout after tripping operation
- Operator panel cannot be taken off with the circuit breaker in the ON position

Additional features of the withdrawable version:

- **Main contacts:** Laminated receptacles in the guide frame, penetration blades on the withdrawable circuit breaker
- Position indicator in the operator panel of the withdrawable circuit breaker
- Captive manual crank handle for moving the withdrawable circuit breaker
- Guide frame with guide rails for easy moving of the withdrawable circuit breaker
- The withdrawable circuit breaker can be locked to prevent it being pushed out of position
- The withdrawable circuit breaker cannot be moved when it is in the ON position
- Coding of the rated current between the guide frame and the withdrawable circuit breaker

Standards

SETRON 3WL circuit breakers comply with:

- IEC 60947-1, IEC 60947-2
- EN 60947-1, EN 60947-2
- Climate-proof according to IEC 60068-2-30

Versions according to UL 489 also available, see Catalog LV 16. For further specifications, see Appendix.

3WL Air Circuit Breakers

3WL Air Circuit Breakers/Non-Automatic Air Circuit Breakers up to 6300 A (AC)

General data

Withdrawable short-circuit, grounding, and bridging units

Portable positively-driven grounding and short-circuit devices are used for the disconnected system sections to verify isolation from the supply at the workplace.

Withdrawable grounding units allow simple and comfortable grounding. They are simply inserted into the guide frames in place of the corresponding withdrawable circuit breakers. This ensures that these devices are always first connected with the grounding electrode and then with the components to be grounded.

The grounding terminals are fitted to the side of the switch enclosure and establish the connection when inserted into the guide frame.

Short-time current of the grounding terminal	kA	15 (500 ms)
Rated operational voltage	V	1000 (690 for size I)
Standards		EN 61230

All withdrawable terminals are short-circuited and grounded on delivery.

Qualified electricians can easily convert it to a withdrawable bridging unit by following the enclosed instructions.

In addition, the withdrawable unit can be adapted to various rated currents of a size.

Withdrawable short-circuit and grounding unit

The withdrawable short-circuit and grounding unit consists of a breaker enclosure with penetration blades which are connected with the short-circuiting link.

Depending on the version, the short-circuiting links are arranged at the top or bottom. The grounding and short-circuit connections are established when the device is inserted.

It must be ensured that the side to be short-circuited and grounded is not live. For this reason it is recommended that the withdrawable unit is only wound in when the door is closed.

Withdrawable bridging unit

The withdrawable bridging unit consists of a breaker enclosure in which all disconnection components and the operating mechanism have been replaced with simple connections between the upper and lower contacts.

Auxiliary releases

Up to two auxiliary releases can be installed at the same time. The following are available:

- 1 shunt release
- or 1 undervoltage release
- or 2 shunt releases
- or 1 shunt release
- + 1 undervoltage release

Signal switch for auxiliary releases

One signaling contact is used for each auxiliary release to determine the positions of the auxiliary releases.

Shunt releases

When the operational voltage is connected to the shunt release, the circuit breaker is opened immediately. The shunt release is available in the versions 5 % ON period for overexcitation and 100 % ON period for permanent excitation. This means that it is also possible to block the circuit breaker against being jogged into closing.

An energy storage device for shunt releases allows the circuit breaker to be opened even if the control voltage is no longer available.

Undervoltage releases

The undervoltage release causes the circuit breaker to be opened if the operational voltage falls below a certain value or is not applied. The circuit breaker cannot be closed manually or by means of an electrical ON command if the undervoltage release is not connected to the operational voltage. The undervoltage release has no delay as standard. A delay can be set by the customer in the range between $t_d < 80$ ms and $t_d < 200$ ms.

In addition, an undervoltage release with a delay in the range from 0.2 to 3.2 s is available.

Closing solenoid

The closing solenoid is used to close the circuit breaker electrically by means of a local electrical ON command or by a remote unit.

Motorized operating mechanisms

The operating mechanism is used to load the storage spring automatically.

The operating mechanism is activated if the storage spring has been unloaded and the control voltage is available.

It is switched off automatically after loading. This does not affect manual operation of the storage spring.

Indicators, signals, and control elements

Motor shutdown switch

Control switch for switching off the motorized operating mechanism (automatic loading).

Operating cycles counter

The motorized operating mechanism can be supplied with a 5-digit operating cycles counter. The display is incremented by "1" as soon as the storage spring is fully loaded.

Resetting the manual tripped signal

When the circuit breaker has tripped, this is indicated by the protruding red mechanical tripped indicator on the ETU. When the mechanical tripped indicator is activated, the tripping solenoid and tripped signal are reset. If this display is to be reset remotely, the reset button can be equipped with a reset solenoid.

This option allows the circuit breaker to be reset both manually and electrically.

Automatic resetting of reclosing lockout

When the ETU is activated, reclosing of the circuit breaker is prevented until the release is either electrically or manually reset. If the "Automatic resetting of reclosing lockout" option is used, the pre-tensioned circuit breaker is ready to close immediately after tripping. Resetting the manual tripped indicator is not included in this option.

Tripped signal switch

If the circuit breaker has tripped due to an overload, short-circuit, ground fault or extended protection function, the tripped signal switch can indicate this. This signal switch is available as an option. If the circuit breaker is used for communication, this option is supplied as standard.

Ready-to-close indicator switch

The SENTRON 3WL circuit breakers are equipped with an optical ready-to-close indicator as standard. In addition, the ready-to-close status can be transmitted by means of a signal switch as an option. If the switch is used for communication, the signal switch is supplied as standard.

3WL Air Circuit Breakers

3WL Air Circuit Breakers/Non-Automatic Air Circuit Breakers up to 6300 A (AC)

General data

Circuit breakers

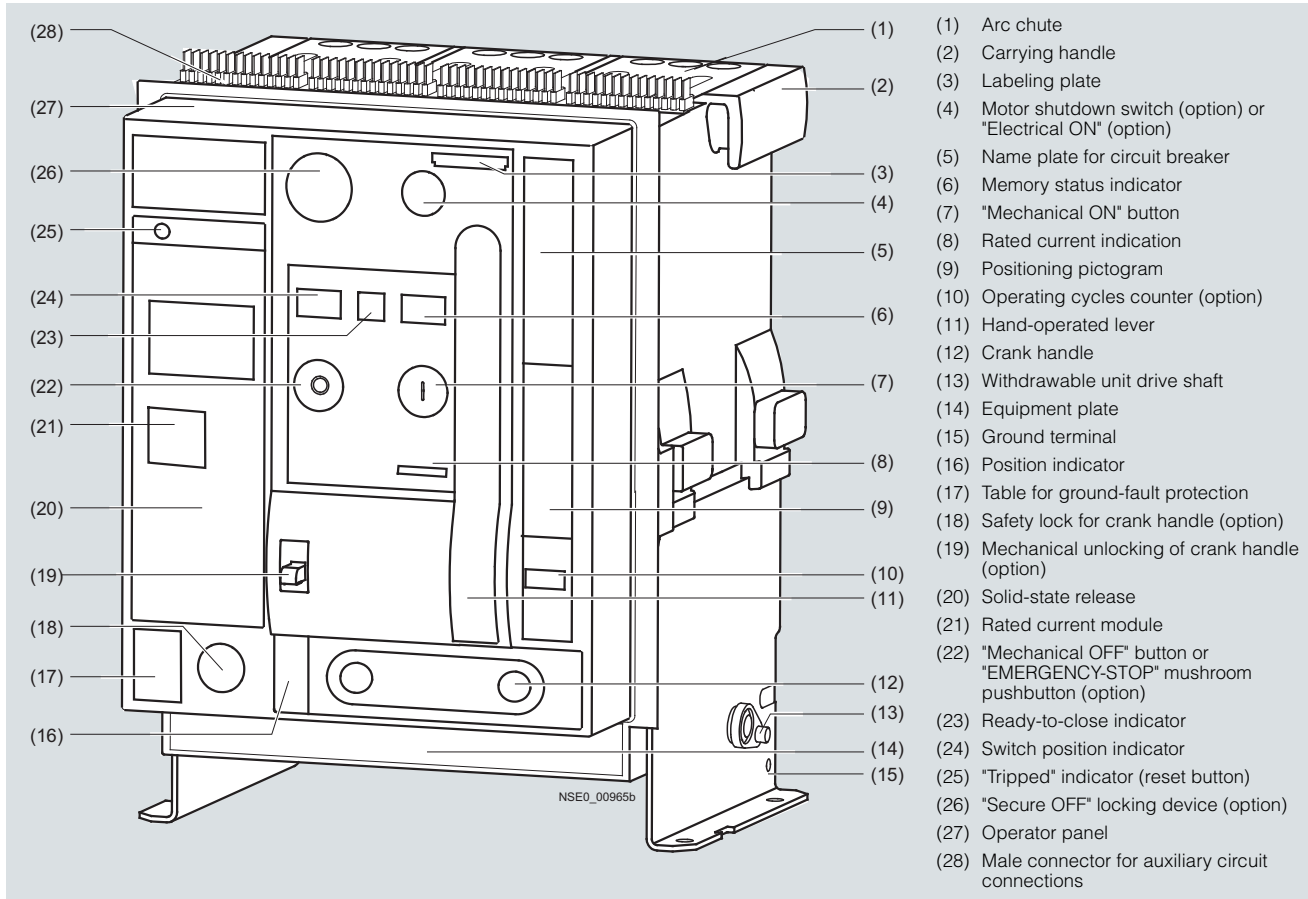

Guide frames

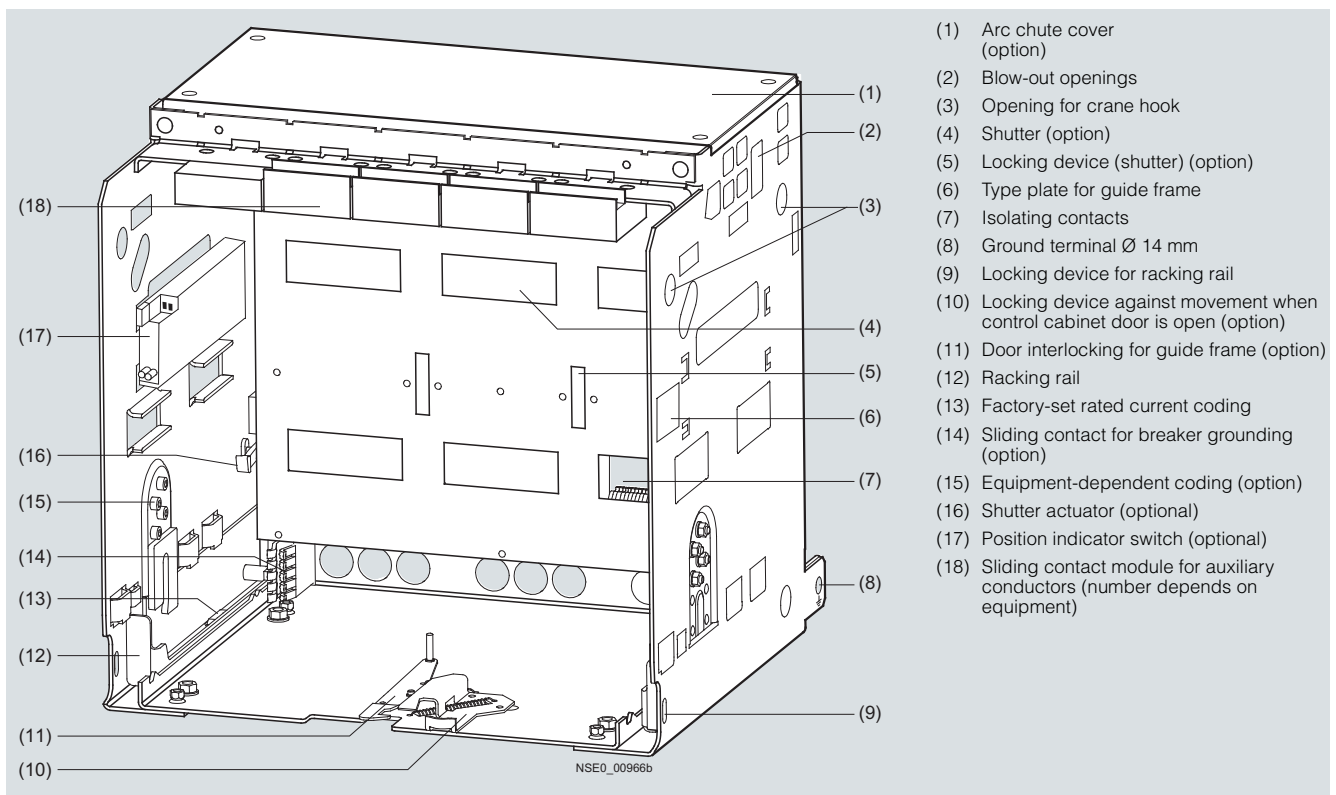

3WL Air Circuit Breakers

3WL Air Circuit Breakers/Non-Automatic Air Circuit Breakers up to 6300 A (AC)

General data

Locking devices

Locking device in OFF position

This function prevents closing of the circuit breaker and complies to the specifications for main switches to EN 60204 (VDE 0113) - disconnecter unit. This lockout only affects this circuit breaker.

If the circuit breaker is replaced, closing is no longer prevented unless the new circuit breaker is also protected against unauthorized closing.

To activate the locking device, the circuit breaker must be opened. The locking device is disabled when the circuit breaker is closed. The lock is only activated when the key is removed. The safety key can be removed only in the "OFF" position.

Locking device for "Electrical ON"

(see graphic "Circuit breakers")

This prevents unauthorized electrical closing from the operator panel. Mechanical closing and remote closing remain possible. The lock is only activated when the key is removed.

Locking device for "Mechanical ON"

(see graphic "Circuit breakers")

This prevents unauthorized mechanical closing. The mechanical ON button can only be activated if the key is inserted (key operation). Closing with the "Electrical ON" button and remote closing remain possible. The lock is only activated when the key is removed.

"Secure OFF" circuit breaker-independent locking device against unauthorized closing

This special switch-independent function for withdrawable circuit breakers prevents closing and fulfills the specifications for main switches to EN 60204 (VDE 0113) – disconnecter unit. Unauthorized closing remains impossible even after the circuit breaker has been exchanged.

To activate the lock, the circuit breaker must be opened. The locking device is disabled when the circuit breaker is closed. The lock is only activated when the key is removed. The safety key can be removed only in the "OFF" position.

Locking device for crank handle

Prevents removal of the crank. The circuit breaker is protected against movement. The lock is only activated when the key is removed.

Locking device for "Mechanical OFF"

Prevents unauthorized mechanical opening from the operator panel. The "Mechanical OFF pushbutton" can only be activated if the key is inserted (key operation). Remote opening remains possible. The lock is only activated when the key is removed.

Locking device for hand-operated lever

The hand-operated lever can be locked with a padlock. The storage spring cannot be loaded manually.

Locking device against resetting the "tripped" indicator

A lockable cover prevents manual resetting of the "tripped" indicator after overcurrent tripping. This locking device is supplied together with the transparent cover for solid-state releases.

Sealing devices

Sealing cap for "Electrical ON" button

The "Electrical ON button" is equipped with a sealing cap as standard.

Sealing cap for "Mechanical ON" and "OFF" button

The locking set contains covering caps which can be sealed.

Sealing device for solid-state releases

The transparent cover can be sealed. The parameter setting sections are covered to prevent unauthorized access. Openings allow access to the query and test button.

Locking mechanisms

Locking mechanism against movement for withdrawable circuit breakers when the control cabinet door is open

The crank handle is blocked when the control cabinet door is open and cannot be removed. The withdrawable circuit breaker cannot be moved. The lock only affects the inserted crank handle.

Locking of the control cabinet door

The control cabinet door cannot be opened if

- The fixed-mounted circuit breaker is closed (the blocking signal is transmitted via the Bowden wire) or
- The withdrawable circuit breaker is in the connected position.

Blocking mechanism using "Mechanical ON" and "OFF" buttons

The "Mechanical ON" and "OFF" buttons are covered with a cap which only allows actuation with a tool. These covering caps are part of the locking set.

Optional equipment for guide frames

Shutters

The sealing strips of the shutter seal the laminated contacts of the guide frame when the withdrawable circuit breaker is removed and therefore implement touch protection.

The sealing strips can be manually opened using the strip levers.

The position of the sealing strips can be locked in various positions using padlocks for securing against tampering.

3WL Air Circuit Breakers/Non-Automatic Air Circuit Breakers up to 6300 A (AC)

General data

Rated current coding unit between circuit breaker and guide frame

Withdrawable circuit breakers and guide frames are equipped with a rated current coding unit as standard.

This ensures that only circuit breakers whose penetration blades are suited to the laminated contacts of the guide frame can be inserted into a guide frame (see diagram below).

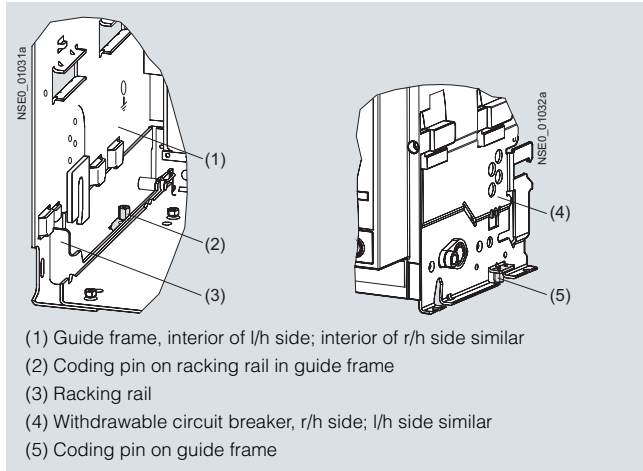

- (1) Guide frame, interior of l/h side; interior of r/h side similar
 (2) Coding pin on racking rail in guide frame
 (3) Racking rail
 (4) Withdrawable circuit breaker, r/h side; l/h side similar
 (5) Coding pin on guide frame

Rated current coding unit between circuit breaker and guide frame

Equipment-dependent coding

Withdrawable circuit breakers and guide frames can be retrofitted with an equipment-dependent coding unit.

This allows different designs of circuit breakers and guide frames to be uniquely assigned. If the circuit breaker and guide frame have been assigned different codes, the circuit breaker cannot be inserted.

36 different coding options can be selected.

Position indicator switch for guide frames

The guide frame can be equipped with position indicator switches. These can be used to determine the position of the circuit breaker in the guide frame.

Two versions are available:

- Option 1
 Connected position 1 CO contact,
 test position 1 CO contact,
 disconnected position 1 CO contact.
- Option 2
 Connected position 3 CO contacts,
 test position 2 CO contacts,
 disconnected position 1 CO contact.

Positions of the withdrawable circuit breaker in the guide frame

	Display	Position indicator	Main circuit	Auxiliary circuit	Control cabinet door	Shutters
Maintenance position	NSE0_01033a	NSE01037	Disconnected	Disconnected	Open	Closed
Disconnected position	NSE0_01034a	NSE01038	Disconnected	Disconnected	Closed	Closed
Test position	NSE0_01035a	NSE01039	Disconnected	Connected	Closed	Closed
Connected position	NSE0_01036a	NSE01040	Connected	Connected	Closed	Open

- (1) Auxiliary circuit (2) Main circuit (3) Control cabinet door (4) Shutter

Phase barriers

The plant engineering company can manufacture phase barriers made of insulating material for the arcing fault barriers. The rear panel of the fixed-mounted circuit breakers or guide frames are equipped with guide grooves.

Arc chute cover

The arc chute cover is available as optional equipment for the guide frame. It protects switchgear components which are located directly above the circuit breaker.

Door sealing frame and cover

SENTRON 3WL circuit breakers have degree of protection IP20 as standard. However, if the switchgear is to be equipped with a higher degree of protection, a door sealing frame with IP41 and a cover with IP55 are available.

3WL Air Circuit Breakers

3WL Air Circuit Breakers/Non-Automatic Air Circuit Breakers up to 6300 A (AC)

General data

Function

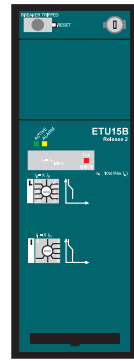

NSE0_00880b

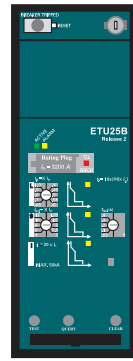

NSE0_00881b

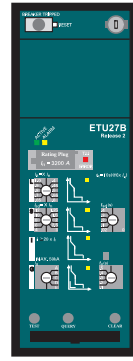

NSE0_00882b

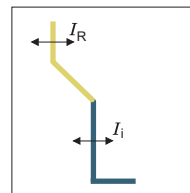

NSE0_00950c

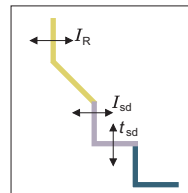

NSE0_00951b

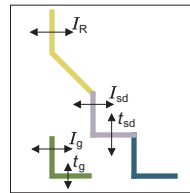

NSE0_00952b

ETU15B

ETU25B

ETU27B

Functions of the solid-state releases

Basic protection functions

Overload protection	L	✓	✓	✓
Short-time delayed short-circuit protection	S	--	✓	✓
Instantaneous short-circuit protection	I	✓	✓	✓
Neutral conductor protection	N	--	--	✓
Ground-fault protection	G	--	--	✓

Additional functions

N-conductor protection can be switched on/off		--	--	✓
N-conductor protection adjustable		--	--	--
Instantaneous short-circuit protection can be switched on/off		--	--	--
Non-delayed short-circuit protection can be switched on/off		--	--	--
Thermal image can be switched on/off		--	--	--
Load monitoring		--	--	--
Short-time delayed short-circuit protection switchable to I^2t		--	--	--
Instantaneous short-circuit protection adjustable		✓	--	--
Overload protection switchable to I^4t		--	--	--
Overload protection can be switched on/off		--	--	--
Selectable parameter sets		--	--	--

Parameterization and display

Parameterization through rotary coding switches (10 steps)		✓	✓	✓
Parameterization through communication (absolute values)		--	--	--
Parameterization through user interface of ETU (absolute values)		--	--	--
Parameterization of the extended protection functions		--	--	--
LCD alphanumerical		--	--	--
Graphic LCD		--	--	--

Measurement function

Measurement function <i>Plus</i>		--	--	--
----------------------------------	--	----	----	----

Communication

CubicleBUS		--	--	--
Communication through PROFIBUS DP		--	--	--
Communication through MODBUS		--	--	--
Communication through Ethernet		--	--	--

✓ Standard -- Not available □ Optional

Detailed information about the functions of the solid-state releases is given in the following.

3WL Air Circuit Breakers

3WL Air Circuit Breakers/Non-Automatic Air Circuit Breakers up to 6300 A (AC)

General data

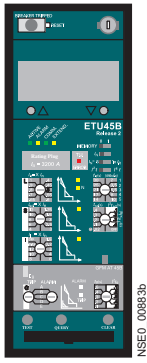

NSE0_00883b

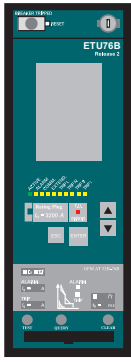

NSE0_00886c

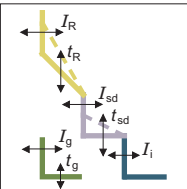

NSE0 00953a

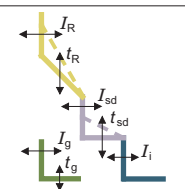

NSE0 00953a

ETU45B

ETU76B

	ETU45B	ETU76B
	✓	✓
	✓	✓
	✓	✓
	✓	✓
	□	□
	✓	✓
	✓	✓
	✓	✓
	✓	✓
	✓	✓
	✓	✓
	✓	✓
	✓	✓
	✓	✓
	--	✓
	--	✓
	✓	--
	--	✓
	--	✓
	□	□
	□	--
	--	✓
	□	□
	□	□
	✓	✓
	□	□
	□	□
	□	□

3WL Air Circuit Breakers

3WL Air Circuit Breakers/Non-Automatic Air Circuit Breakers up to 6300 A (AC)

General data

Solid-state releases (ETU)

The solid-state release is controlled by a microprocessor and operates independently of an auxiliary voltage. It enables systems to be adapted to the different protection requirements of distribution systems, motors, transformers and generators.

Communication capabilities

The international standard PROFIBUS DP or MODBUS can be used to transmit data such as current values, switching states, reasons for tripping etc. to central computers.

Data acquisition and energy management are possible in conjunction with the *Plus* measurement function.

A new internal circuit breaker data bus allows switchboard panel communication between the circuit breaker and secondary devices in the circuit breaker section:

- Actuation of analog displays
- Facility to test the communication build-up with circuit breakers
- Display of tripping state and tripping reasons
- Input module for reading in further switchgear panel signals and for transmission of these signals to the PROFIBUS DP or MODBUS
- Various output modules for displaying measured values

This means that it is not only possible to monitor the device remotely, but also to transmit current values from the entire system and perform switching operations remotely.

I^2t and I^4t characteristic curve for overload protection

The best protection for the whole switchgear is achieved by setting the tripping characteristic curve to an optimum value. In order to achieve optimal discrimination for upstream fuses or medium voltage protection systems, the inclination of the characteristic curve can be selected for the overload range.

The overload protection L (long time protection) for the solid-state releases ETU45B and ETU76B allows the characteristic curve to be switched between I^2t and I^4t .

The I^4t characteristic improves discrimination for downstream circuit breakers and fuses.

Solid-state releases ETU

Modularity has also been strictly emphasized during the development of the solid-state releases. These are some of the modules which can be easily retrofitted at any time:

- Ground-fault protection module
- Communication
- Measurement function
- Display
- Rated current module (Rating Plug)

This allows quick adaptation to new local mains specifications. In addition, innovative functions have been included in the ETUs.

Rated current module/Rating Plug

The rated current module is an exchangeable module which allows the user to reduce the rated device current so as to adapt it optimally to the plant; e. g. if a new plant section is taken into operation. The rated current module must be selected to fit the rated current of the plant.

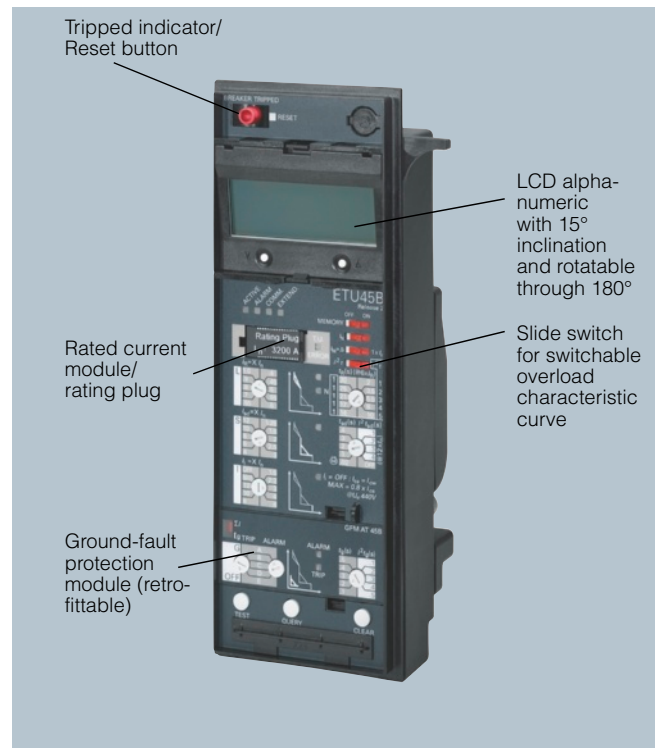

Example of configuration for ETU45B



Measurement function *Plus*

Selectable parameters

In the case of quick changes of power supply conditions, e. g. for switchovers from transformer to generator operation or if a section of the supply is disconnected when the shift changes, SENTRON 3WL allows the relevant protection parameters to be quickly adapted to the new conditions. The ETUs contain two independent tripping characteristic curves (parameter sets). The switchover is completed within 200 ms and is performed with the help of an external signal.

3WL Air Circuit Breakers/Non-Automatic Air Circuit Breakers up to 6300 A (AC)

General data

ETU15B solid-state release

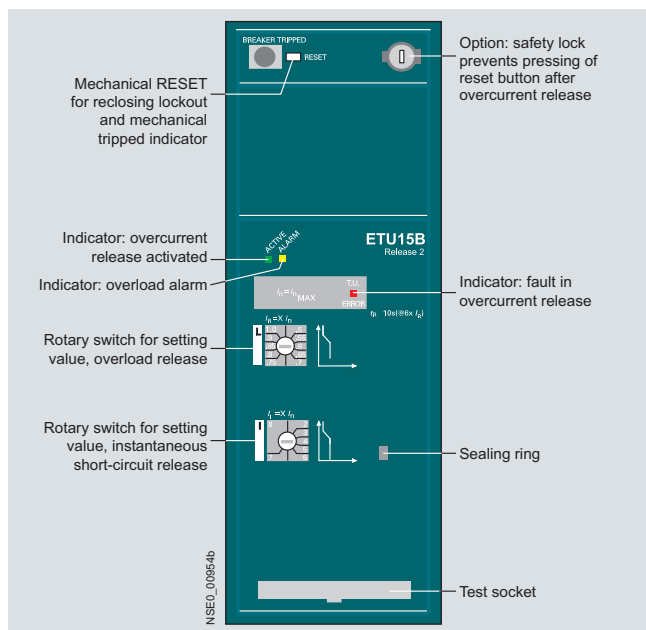

Application:

Simple building and system protection without time-selective coordination up to 4000 A. Not to be used for size III.

Features:

- Adjustable overload protection with I^2t characteristic curve with preset delay time $t_R = 10$ seconds at $6 \times I_R$
- Instantaneous short-circuit protection adjustable in the range $2 \dots 8 \times I_n$
- Overload display
- Protection function is set by means of the rotary coding switch

For technical details see the table "Functional overview of the solid-state release system" under "Technical specifications".

ETU25B solid-state release

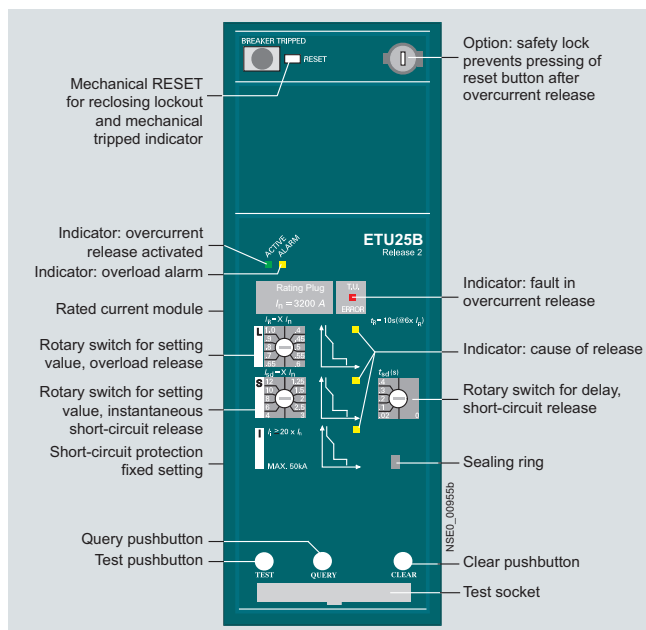

Application:

Classical building, motor and system protection with time-selective coordination for up to 6300 A

Features:

- Adjustable overload protection with I^2t characteristic curve
Delay time $t_R = 10$ seconds at $6 \times I_R$
- Short-time delayed short-circuit protection adjustable in the range $1.25 \dots 12 \times I_n$ and
- Instantaneous short-circuit protection preset to $20 \times I_n$, max. 50 kA
- Can be adapted at any time to the required plant currents through retrofittable rated current module, thus ensuring overload protection in the range from 100 A to 6300 A
- Overload display
- Indicates the reason for tripping by means of an LED
- Test facility for the release
- Protection functions are set by means of the rotary coding switch

For technical details see the table "Functional overview of the solid-state release system" under "Technical specifications".

3WL Air Circuit Breakers

3WL Air Circuit Breakers/Non-Automatic Air Circuit Breakers up to 6300 A (AC)

General data

ETU27B solid-state release

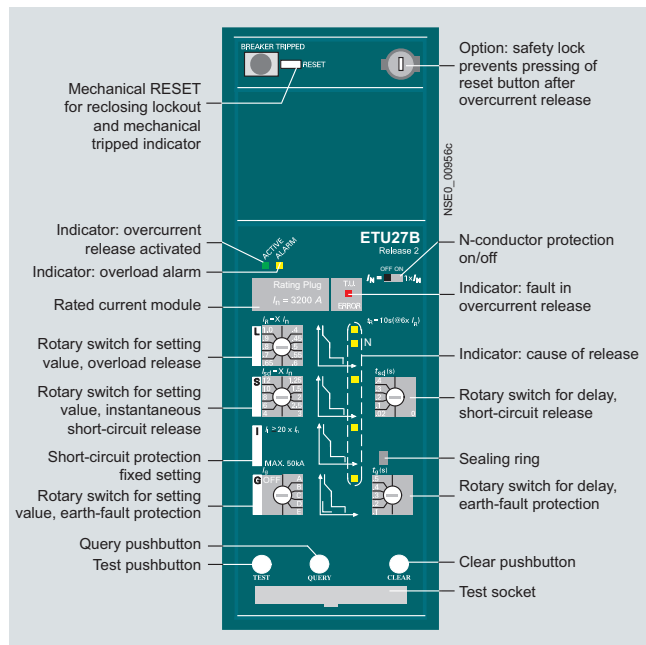

Application:

Classical building, motor and system protection with time-selective coordination for up to 6300 A

Features:

The same as ETU25B but also

- Reversible neutral conductor protection
- Permanently integrated ground-fault protection. Calculation of the ground-fault current through vectorial summation current formation

For technical details see the table "Functional overview of the solid-state release system" under "Technical specifications".

ETU45B solid-state release

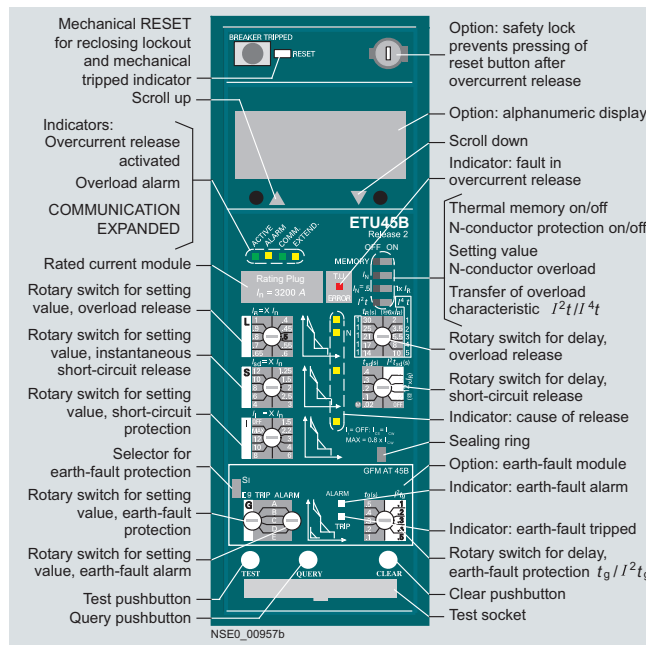

Application:

Low-cost all-round system for intelligent buildings and all types of industrial applications – "CubicleBUS integrated"

Features:

The same as ETU25B but also

- Adjustable time-lag class for overload protection
- Selectable characteristic for overload and short-delayed short-circuit range (current discrimination) for more accurate discrimination adaptation to upstream fuses and protective devices
- Thermal image as restart protection for tripped motor outgoing feeders
- Reversible and adjustable neutral conductor protection
- Modular ground-fault protection module with alarm and tripping functions which can be adjusted separately
- Communication interface, measurement function *Plus*, optional connection of external modules or for retrofitting
- Storage of events and causes for tripping for detailed fault analysis
- Extended protection function possible with measurement function
- Optional high-contrast display with viewing angle adjustment option
- The protection functions can be set by means of a rotary coding switch or slide switch

For technical details see the table "Functional overview of the solid-state release system" "Technical specifications".

3WL Air Circuit Breakers

3WL Air Circuit Breakers/Non-Automatic Air Circuit Breakers up to 6300 A (AC)

General data

ETU76B solid-state release

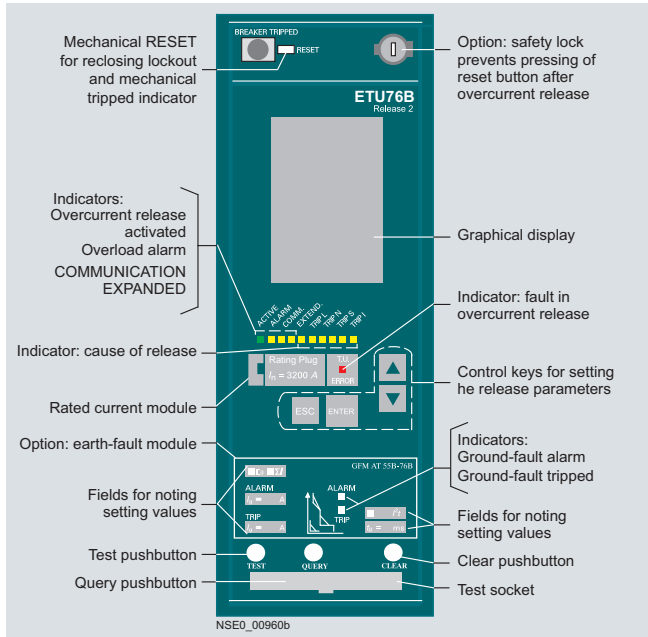

Application:

The multi-talent with graphical display for system analysis – "CubicleBUS integrated"

Features:

The same as ETU45B but also including

- Two protection parameter sets which can be stored separately in the release (switchover is performed by means of external signal)
- With overload protection which can be deactivated for operation in modern drive technology
- Adjustable delay of delayed short-circuit protection up to 4000 ms
- Neutral conductor protection adjustable up to $I_N = 200\% I_N$
- Setting of protection functions by means of Breaker Data Adapter (BDA) or via communications interface
- Graphical display of all parameters and events/curve trends
- Graphics display with high contrast, backlit display, and sleep mode

For technical details see the table "Functional overview of the solid-state release system" under "Technical specifications".

Ground-fault protection

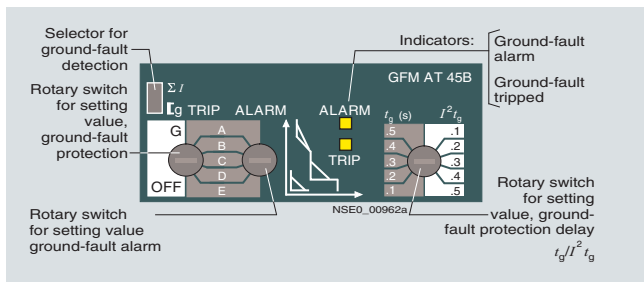

GFM AT 45B ground-fault module

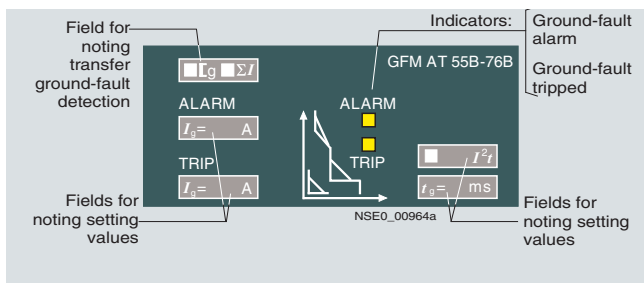

GFM AT 55B-76B ground-fault module

Ground-fault releases "G" sense fault currents that flow to ground and that can cause fire in the plant. Multiple circuit breakers connected in series can have their delay times adjusted so as to provide graduated discrimination.

When setting the parameters for the solid-state release it is possible to choose between "alarm" and "trip" in the event that the set current value is exceeded. The reason for tripping is indicated by means of an LED when the query button is activated.

The ETU45B and ETU76B solid-state release versions can be retrofitted with a ground-fault protection module. This ground fault protection function is integrated in ETU27B solid-state releases.

3WL Air Circuit Breakers

3WL Air Circuit Breakers/Non-Automatic Air Circuit Breakers up to 6300 A (AC)

General data

Measurement method

Vectorial summation current formation (measurement method 1)

The three phase currents and the N conductor current are measured directly.

The solid-state release determines the ground-fault current by means of vectorial summation current formation for the three phase currents and the N conductor current.

Direct measurement of the ground-fault current (measurement method 2)

A standard current transformer with the following data is used for measurement of the ground-fault current: 1200 A/1 A, Class 1 (the internal load of SENTRON 3WL is 0.11 Ω). The current transformer can be installed directly in the grounded neutral point of a transformer.

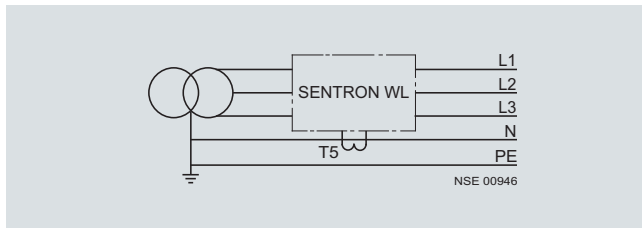

3-pole circuit breakers, current transformers in the N conductor

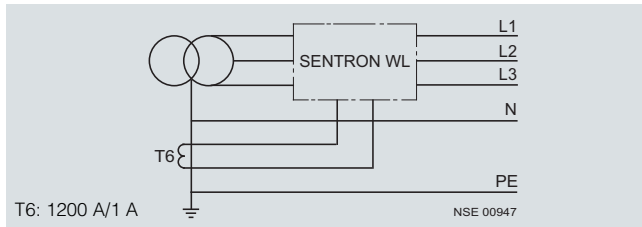

3-pole circuit breakers, current transformers in the grounded neutral point of the transformer

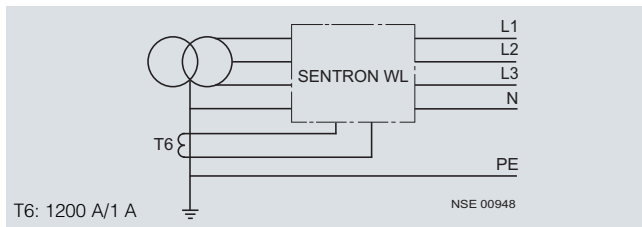

4-pole circuit breakers, current transformers in the grounded neutral point of the transformer

Setting

How the module is set depends on the measurement method used (see above):

Measurement method 1: in position ΣI .

Measurement method 2: in position ΣI_g .

This setting can be implemented for the solid-state release version ETU76B with Menu/Comm.

Ground-fault protection with i^2t characteristic curve

With the exception of the ETU27B solid-state release, all versions of the ground-fault modules are supplied with an i^2t characteristic curve which can be activated.

Selection criteria for SENTRON 3WL circuit breakers

Basic criteria for selecting circuit breakers are:

- **Max. short-circuit current** at place of installation of circuit breaker $I_k''_{max}$
This value determines the short-circuit breaking capacity or short-circuit current carrying capacity of the circuit breaker.
- It is compared with the value I_{cu} , I_{cs} , I_{cw} of the circuit breaker and essentially determines the size of the circuit breaker. See illustration "Overview of SENTRON 3WL Circuit Breakers/Non-Automatic Air Circuit Breakers".
- **Rated current** I_n which is to flow through the branch circuit. This value must not be larger than the maximum rated current for the circuit breaker. The rated current for the SENTRON 3WL is set with the rated current module. See "Design", illustration "Overview of SENTRON 3WL Circuit Breakers/Non-Automatic Air Circuit Breakers".
- **Ambient temperature** for the circuit breaker. This is usually the control cabinet internal temperature.
- **Design** of the circuit breaker
- **Minimum short-circuit current** which flows through the switching device. The release must still detect this value as a short-circuit and must respond by tripping.

Protection functions of the circuit breaker.

These are determined by the selection of the corresponding solid-state release, see the table "Functions of the solid-state releases" under "Functions".

3WL Air Circuit Breakers/Non-Automatic Air Circuit Breakers up to 6300 A (AC)

General data

SENTRON 3WL for DC applications

This version of the 3WL non-automatic air circuit breaker is suitable for direct current applications. The external protective device DIGmat S100 provides adjustable overload and short-circuit protection for the SENTRON 3WL non-automatic air circuit breaker.

This is based on the measuring chain of a shunt resistor and the DIGmat S100 tripping unit. Shunt resistors are available for 1000 A, 2000 A and 4000 A (special ranges on request). They are in accordance with DIN 43703 and have a class accuracy of 0.5.

A measuring-circuit voltage of 60 mV DC is picked off for rated current I_n .

The measuring-circuit voltage is a linear image of the primary current.

The DIGmat S100 tripping unit monitors the image of the primary current thus supplied and compares it with the tripping characteristic curve set on the device. The parameter settings on the DIGmat S100 apply also for DC feedbacks. Reversing duty is possible therefore.

The tripping characteristic curve is determined and described by the following variables:

- Overload protection:
Setting range $I_R = 0.4 \dots 1.0 I_n$
The curve has a I^2t characteristic.
The tripping time t_R is selectable between 2 and 10 s, with t_R defined for $6 \times I_R$.

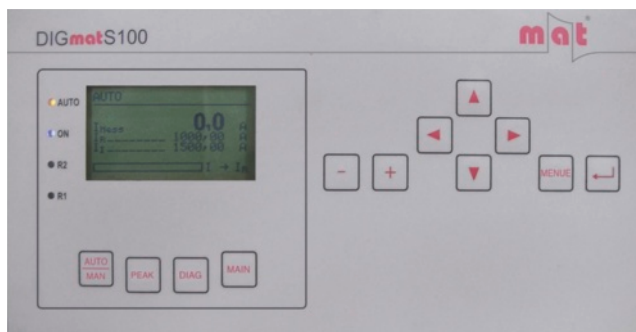

DIGmat S100

- Short-circuit protection:
Setting range $I_i = 1.25 \times I_R$ up to max. $4 \times I_n$
If the set value is exceeded, tripping occurs in less than 50 ms.
 I_n = Rated current of the circuit breaker
 I_R = Set current value of the adjustable overload release
 t_R = Assigned tripping time of the overload trip
 I_i = Instantaneous tripping current of the adjustable short-circuit releases

The components are available only from the company mat – Maschinen- und Anlagentechnik (for address see "Appendix" => "External Partners").

Configuration

Mutual mechanical circuit breaker interlocking

The module for mutual mechanical interlocking can be used for one or two SENTRON 3WL circuit breakers and can be adapted easily to the corresponding versions. The fixed-mounted and withdrawable circuit breaker versions are fully compatible and can therefore be used in a mixed configuration in an installation. This also applies to 3WN6 circuit breakers.

The circuit breakers can be mounted alongside each other or one above the other, whereby the distance of the circuit breakers is determined solely by the length of the Bowden wire (lengths: 2 m/3 m/4.5 m). Interlock signals are looped through using the Bowden wires. Interlocking is only effective in the connected position in the case of withdrawable circuit breakers. The mechanical endurance of the Bowden cables is 10 000 operating cycles.

Minimum requirements must be fulfilled in the switchgear for the interlocking to function:

- Bowden wires must be installed as far as possible in a straight line with minimum bending.

- The bending radii of the Bowden wire must be greater than 500 mm.
- The sum of all bending angles along the Bowden wire must not exceed 640°.
- In a vertical arrangement of circuit breakers to be interlocked, the interlocking mechanisms must be in line.
- Circuit breakers to be interlocked must be arranged so that Bowden cables can be optimally installed in compliance with the conditions mentioned in the above points.
- The installed Bowden wire must be fixed (with cable ties or the like) before the interlock is adjusted.
- Select the width of switchgear cubicle to allow enough freedom of movement for adjusting the interlock!
- Openings and cut-outs in system elements must be designed so that Bowden wires are not changed in direction or obstructed when they are passed through.

Mutual mechanical interlocking of circuit breakers – examples

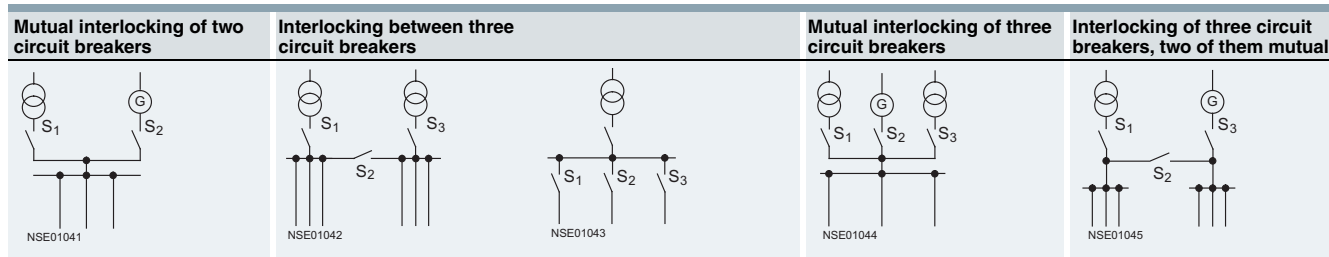

3WL Air Circuit Breakers

3WL Air Circuit Breakers/Non-Automatic Air Circuit Breakers up to 6300 A (AC)

General data

Communication-capable circuit breakers

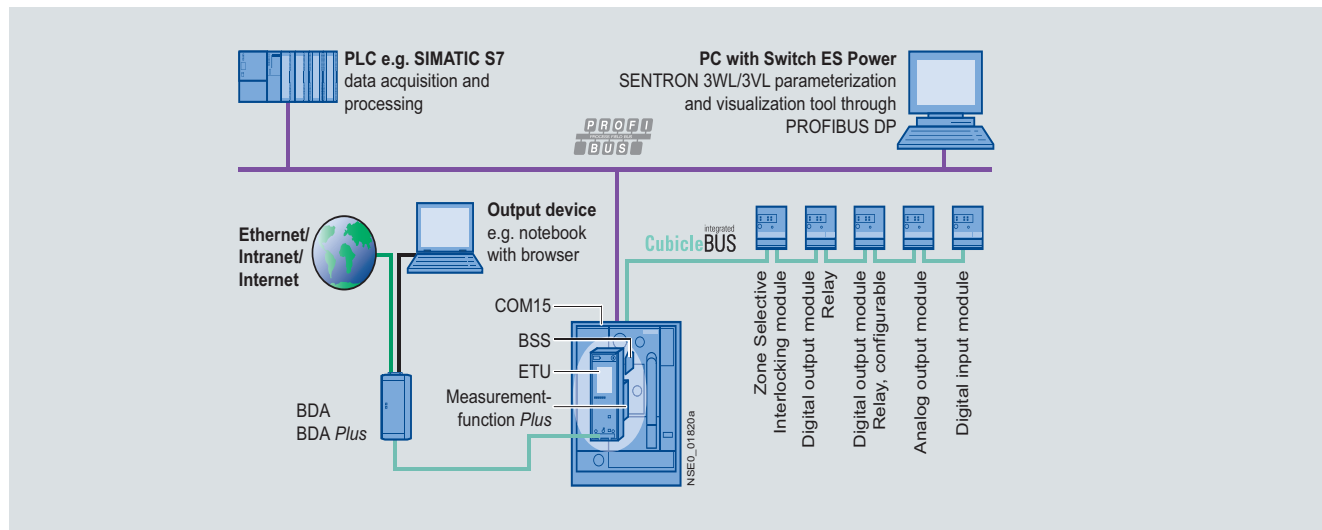

Communication with PROFIBUS DP

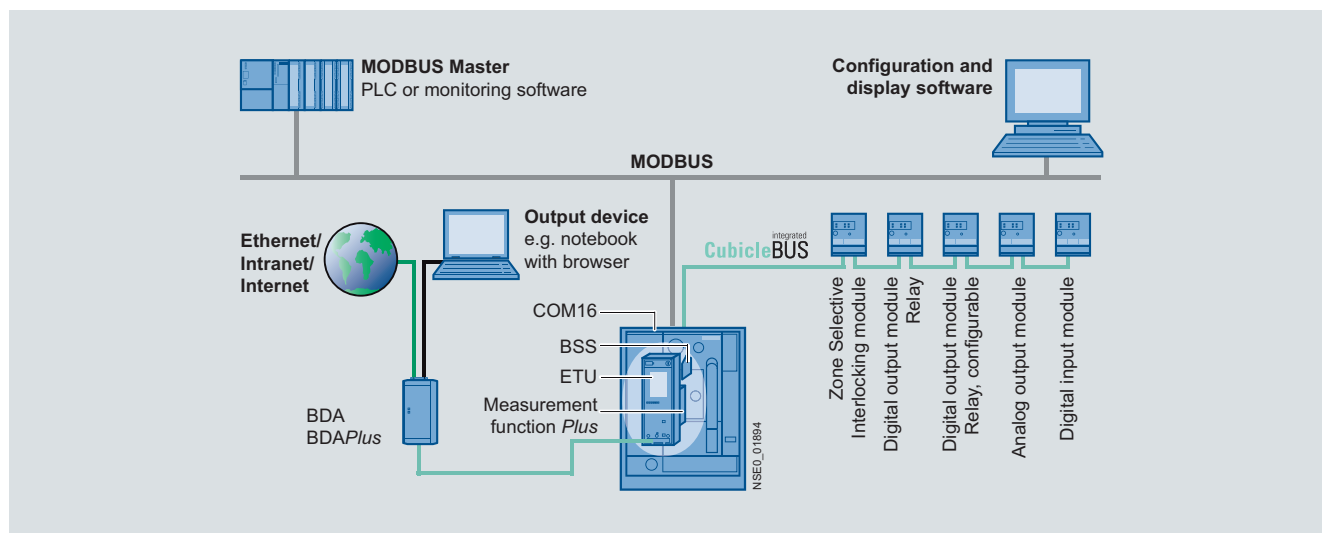

Communication with MODBUS

The requirements for power distribution in terms of communication capability, data transparency, flexibility and integration are constantly increasing. An integrated and modular communication architecture was designed for the SENTRON 3WL to ensure that it can satisfy these requirements.

The core component of this architecture is the **CubicleBUS**, which links together all of the intelligent components within the SENTRON 3WL and enables the easy and safe connection of other additional external components to the circuit breaker. The **CubicleBUS** is already incorporated and pre-connected in all complete circuit breakers with ETU45B and ETU76B releases.

The high level of modularity of the system allows communication functions to be retrofitted at any time (e. g. the measurement function). Similarly, the upgrade of a non-communication-capable SENTRON 3WL (e. g. changeover from ETU25B to ETU45B with **CubicleBUS**) can be carried out easily on site in the plant. All modules connected to the **CubicleBUS** can directly access the existing source data of the circuit breaker, which guarantees the quickest possible access to information and response to events.

Furthermore, additional external modules (including digital inputs/outputs, analog outputs) can be connected to the **CubicleBUS** to provide cost-effective solutions for the automation of further devices in the switchgear.

3WL Air Circuit Breakers

3WL Air Circuit Breakers/Non-Automatic Air Circuit Breakers up to 6300 A (AC)

General data

SENTRON 3WL communication-capable circuit breakers

Function	Solid-state release version		Breaker Status Sensor	PROFI-BUS communication port	Measurement function Plus	Analog output modules	Digital output modules	Digital input modules	ZSI modules	Breaker Data Adapter	Breaker Data Adapter Plus	
	ETU45B	ETU76B										
Functions of the communication-capable SENTRON 3WL circuit breakers												
Indication of measured values in release (current only)	✓	✓	☐	☐	☐	☐	☐	☐	☐	☐	☐	☐
Indication of measured values in release (U, I, P, S, Q , p.f., etc.)	✓	✓	☐	☐	✓	☐	☐	☐	☐	☐	☐	☐
Indication of measured values (current only), parameter, diagnostic values etc. on display	--	✓	☐	☐	☐	☐	☐	☐	☐	☐	☐	☐
Indication of measured values (U, I, P, S, Q , p.f., etc.), parameters, diagnostic values etc. in release	--	✓	☐	☐	✓	☐	☐	☐	☐	☐	☐	☐
Output of measured values (current only) to rotary coil instruments in control cabinet door	✓	✓	☐	☐	☐	✓	☐	☐	☐	☐	☐	☐
Output of measured values (U, I, P, S, Q , p.f., etc.) to rotary coil instruments in control cabinet door	✓	✓	☐	☐	✓	✓	☐	☐	☐	☐	☐	☐
Output of digital signals (e. g. reason for tripping, alarm signals, status) through contacts	✓	✓	☐	☐	☐	☐	✓	☐	☐	☐	☐	☐
Automatic changeover between parameter sets A and B	--	✓	☐	☐	☐	☐	☐	✓	☐	☐	☐	☐
Read in digital signals and forward to PROFIBUS/MODBUS	✓	✓	☐	✓	☐	☐	☐	✓	☐	☐	☐	☐
Transmission of switch information on HTML basis locally to a PC	✓	✓	✓	☐	☐	☐	☐	☐	☐	☐	✓	✓
Transmission of switch information on HTML basis through Ethernet	✓	✓	✓	☐	☐	☐	☐	☐	☐	☐	☐	✓
Short-time grading control for S tripping and G protection	✓	✓	☐	☐	☐	☐	☐	☐	✓	☐	☐	☐
Local display of harmonic analysis and waveform memory	--	✓	☐	☐	✓	☐	☐	☐	☐	☐	☐	☐
Local storage of harmonic analysis and waveform memory and transmission through PROFIBUS	✓	✓	✓	✓	✓	☐	☐	☐	☐	☐	☐	☐
Read out protection parameters through PROFIBUS	✓	✓	✓	✓	☐	☐	☐	☐	☐	☐	☐	☐
Read out and adjust protection parameters through PROFIBUS	--	✓	✓	✓	☐	☐	☐	☐	☐	☐	☐	☐

✓ Required

☐ Function can optionally be taken over by more than one release.

☐ Function can optionally be taken over by one of these modules.

☐ Not necessary for this function, optionally combinable

-- Function not available

3WL Air Circuit Breakers

3WL Air Circuit Breakers/Non-Automatic Air Circuit Breakers up to 6300 A (AC)

General data

Data that can be transmitted over the PROFIBUS DP/MODBUS or the Breaker Data Adapter

All SENTRON 3WLs with ETU45B, ETU76B (CubicleBUS integrated)



Transmittable circuit breaker data

	BSS F01 +"BDA/BDAPLUS" Order No.	BDA	BSS F02/F12	COM15/COM16
Order code (Order No. of circuit breaker + "-Z")				
Order No.				

Potential applications

Transmission of circuit breaker data to PROFIBUS DP or MODBUS and integration into higher-level visualization systems are possible e. g. in PCS7, Power Management Systems, WinCC (incl. add-ons like the text message radio server)	--			✓
Transmission of circuit breaker data and software (i. e. HTML pages with data) to a local output device, or remotely through Ethernet/Intranet/Internet (without the possibility of integration into higher-level visualization systems) e. g. for monitoring, diagnostics, maintenance and parameterization of individual circuit breakers	✓		--	
Utilization of the functionality of all CubicleBUS modules e. g. configuration of the configurable digital output module, status check of the digital input modules, diagnostics	✓			✓

Transmittable circuit breaker data without integrated measurement function

Device identification Communication address, Order No., circuit breaker in delivery status, circuit breaker parameters (size, number of poles, rated current module etc.), identification numbers, release type, Free text for plant code and comments	✓ --1)			✓ ✓
Operating statuses On/off status message, storage spring, tripped, readiness Switching position (connected, test and disconnected position, removed) for withdrawable circuit breakers, PROFIBUS/MODBUS write protection on/off, free user input	✓ --1) --1)			✓ ✓ ✓
Control commands Switch circuit breaker on/off, switch free user output on/off Reset tripped signal Delete event and history memory Reset the min./max. measured values, reset the maintenance information	--1) ✓ --1) ✓			✓ ✓ ✓ ✓
History Read out the event protocol, read out the release protocol	--1)			✓
Maintenance information Number of tripping operations L, S/I and in total, contact wear Number of operating cycles under load and in total, number of operating hours	✓ --1)			✓ ✓
Event signals Tripped signal with details of the tripping current Alarm signals (e. g. overload) with incoming/outgoing information All of the named event signals with time stamp	✓ --1) --1)			✓ ✓ ✓
Parameterization of the protection functions Reading out of the protection function parameters Settings for the protection function parameters can be changed by means of communication Parameter set switchover possible (set A to set B and back)	✓ ✓2) ✓2)			✓ ✓2) ✓2)
Measured values Phase currents, each with min./max. value Temperature in the circuit breaker with min./max. value Temperature in the control cabinet with min./max. value All of the named measured values with time stamp	✓ --1) --1) --1)			✓ ✓ ✓ ✓



Measurement function
Plus
F05

Order code F01+ ... or F02+ ...

Additional transmittable circuit breaker data with integrated measurement function

Additional event signals Threshold value alarms (e. g. over/underfrequency, over/undervoltage)	✓			
Parameterization of the extended protection functions and setpoints (threshold values) Reading out the parameters of the extended protection functions Settings for the extended protection function parameters can be changed Reading out and adjusting threshold values	✓ ✓ ✓			
Additional measured values Voltages, power, energy, power factor, frequency, each with min./max. value Harmonic analysis Recording of currents and voltages for configurable events in the curve form memory	✓ ✓ ✓			

1) Data only available in conjunction with the COM15 module (BUS connection not required).

✓ Available
-- Not available

2) Only possible with ETU76B.

3WL Air Circuit Breakers/Non-Automatic Air Circuit Breakers up to 6300 A (AC)

General data

CubicleBUS modulesDigital output modules with rotary coding switch

6 items of binary information concerning the state of the circuit breaker (reasons for tripping and warnings) can be output via this module to external signaling devices (e. g. LED, horn) or be used for the selective shut-down of other system components (e. g. frequency converters).

Digital output modules are available in versions with and without a rotary coding switch. On modules with a rotary coding switch it is possible to choose between two signaling blocks each with 6 defined assignments and to set an additional response delay.

All the digital output modules are available as a version with relay outputs (CO contacts, up to 12 A). Up to two modules of this type can be connected to one SENTRON 3WL.



Digital output module with rotary coding switch

Digital output modules, configurable

The configurable output module is available for higher-performance solutions. With this module, random events on the **CubicleBUS** can be switched directly to one of six available outputs or three of these outputs can be assigned with up to six events. In other words, up to six events can be placed on one physical output with OR operation. Either BDA/BDA *Plus* or Switch ES Power is used for configuring.

A relay variant is also available here the same as for the output modules with rotary coding switch. Only one module of this type is possible per SENTRON 3WL.



Digital output module, configurable

Analog output modules

The analog output module can be used to output the following measured values to analog indicators in the control cabinet door:

- $I_{L1}, I_{L2}, I_{L3}, I_N$ or
- $U_{L12}, U_{L23}, U_{L31}, U_{L1N}$ or
- $P_{L1}, P_{L2}, P_{L3}, S_{tot}$ or
- p.f.1, p.f.2, p.f.3, ΔI % or
- $f_{avg}, U_{LLavg}, P_{tot}, p.f. avg$

Four 4-20-mA/0-10-V interfaces are available for this. The measured values to be output are selected with a rotary coding switch. By using the analog output module it is possible to do without additional converters and their conventional installation/wiring in the main current path. Up to two modules of this type can be connected to one SENTRON 3WL.



Analog output module

Digital input modules

With the digital input module, up to 6 additional binary signals (24 V DC) in the circuit breaker environment can be connected to the system. It is thus possible for example to send messages concerning the state of a switch disconnector or a control cabinet door to the PROFIBUS DP/MODBUS.

With the digital input module on the **CubicleBUS** it is also possible for the two different protection parameter sets held in the ETU76B solid-state releases to be switched over automatically in a few milliseconds. It is thus possible, for example, to automatically change the parameters of a coupling switch should the transformer infeed fail.

One module each of this type can be used for holding the six items of digital information and for automatically switching over the parameters.



Digital input module

ZSI modules (short-time grading control)

The use of ZSI modules is recommended when Siemens circuit breakers are arranged in several staggered levels but full grading with the smallest possible delay is to be assured nevertheless.

The circuit breakers are interconnected by these modules. In case of a short-circuit, each affected circuit breaker asks the circuit breakers directly downstream whether the short-circuit has also occurred in the next, lower level. The short-circuit is exactly localized as the result, and only the next upstream circuit breaker in the energy flow direction is switched off.



ZSI module (short-time grading control)

3WL Air Circuit Breakers

3WL Air Circuit Breakers/Non-Automatic Air Circuit Breakers up to 6300 A (AC)

General data

Technical specifications

Size	I				II				III							
Type	3WL11				3WL12				3WL13							
Switching capacity class	N	(N)	S	(S)	N	(N)	S	(S)	H	(H)	H	(H)	C	(C)	C	(C)
Short-circuit breaking capacity																
Rated operational voltage U_e up to 415 V AC																
I_{cu}	kA	55	66	66	80	100	100	150	130							
I_{cs}	kA	55	66	66	80	100	100	150	130							
I_{cm}	kA	121	145	145	176	220	220	330	286							
Rated operational voltage U_e up to 500 V AC																
I_{cu}	kA	55	66	66	80	100	100	150	130							
I_{cs}	kA	55	66	66	80	100	100	150	130							
I_{cm}	kA	121	145	145	176	220	220	330	286							
Rated operational voltage U_e up to 690 V AC																
I_{cu}	kA	42	50	50	75	85	85	150	130							
I_{cs}	kA	42	50	50	75	85	85	150	130							
I_{cm}	kA	88	105	105	165	187	187	330	286							
Rated operational voltage U_e up to 1000 V/1150 V AC																
I_{cu}	kA	--	--	--	--	45	50	70 ⁴⁾	70 ⁴⁾							
I_{cs}	kA	--	--	--	--	45	50	70 ⁴⁾	70 ⁴⁾							
I_{cm}	kA	--	--	--	--	95	105	154 ⁴⁾	154 ⁴⁾							
Rated short-time withstand current I_{cw} of the circuit breakers³⁾																
0.5 s	kA	50	66	66	80	100	100	100	100							
1 s	kA	42	50	55	66	80	100	100	100							
2 s	kA	29.5	35	39	46	65 ^{1)/70²⁾}	80	80	80							
3 s	kA	24	29	32	37	50 ^{1)/65²⁾}	65	65	65							
Short-circuit breaking capacity I_{cc} of the non-automatic air circuit breakers																
Up to 500 V AC	kA	50	66	66	80	100	100	100	100							
Up to 690 V AC	kA	42	50	50	75	85	85	100	100							

(N) Circuit breakers with ECO switching capacity N ($I_{cu} = I_{cs}$ up to 55 kA size I/up to 66 kA size II at 500 V)

(S) Circuit breakers with standard switching capacity S ($I_{cu} = I_{cs}$ up to 66 kA size I/up to 80 kA size II at 500 V)

(H) Circuit breakers with high switching capacity H ($I_{cu} = I_{cs}$ up to 100 kA at 500 V)

(C) Circuit breakers with very high switching capacity C ($I_{cu} = I_{cs}$ up to 150 kA (3-pole)/130 kA (4-pole) at 500 V)

(DC) Circuit breakers with DC switching capacity

These circuit breakers are indicated in the Technical specifications by orange-colored backgrounds.

1) Size II with $I_{n \max} \leq 2500$ A.

2) Size II with $I_{n \max} = 3200$ A and $I_{n \max} = 4000$ A.

3) At a rated voltage of 690 V the I_{cw} value of the circuit breaker cannot be greater than the I_{cu} or I_{cs} value at 690 V.

4) Rated operational voltage $U_e = 1150$ V.

3WL Air Circuit Breakers/Non-Automatic Air Circuit Breakers up to 6300 A (AC)

General data

Size	I			II						
Type	... 3WL11 10			3WL11 12	3WL11 16	3WL12 08	3WL12 10	3WL12 12	3WL12 16	3WL12 20
Rated current I_n at 40 °C, at 50/60 Hz										
Main conductor	A	... 1000	1250	1600	800	1000	1250	1600	2000	
N conductor (only on 4-pole versions)	A	... 1000	1250	1600	800	1000	1250	1600	2000	
Rated operational voltage U_o at 50/60 Hz (for 1000 V version see Catalog LV 1, "Options")	V AC	... 690	... 690	... 690	...	690/1000	690/1000	690/1000	690/1000	690/1000
Rated insulation voltage U_i	V AC	1000	1000	1000	1000	1000	1000	1000	1000	1000
Rated impulse withstand voltage U_{imp}										
• Main current paths	kV	12	12	12	12	12	12	12	12	12
• Auxiliary circuits	kV	4	4	4	4	4	4	4	4	4
• Control circuits	kV	2.5	2.5	2.5	2.5	2.5	2.5	2.5	2.5	2.5
Isolating function acc. to EN 60947-2		Yes	Yes	Yes	Yes	Yes	Yes	Yes	Yes	Yes
Utilization categories		B								
Permissible ambient temperature										
• During operation (in operation with LCD max. 55 °C) ⁴⁾	°C	-25/+70	-25/+70	-25/+70	-25/+70	-25/+70	-25/+70	-25/+70	-25/+70	-25/+70
• During storage (special conditions for LCDs must be observed)	°C	-40/+70	-40/+70	-40/+70	-40/+70	-40/+70	-40/+70	-40/+70	-40/+70	-40/+70
Permissible load										
At rear horizontal main circuit connections	A	1000	1250	1600	800	1000	1250	1600	2000	
• Up to 55 °C (Cu bare) ⁵⁾	A	1000	1250	1600	800	1000	1250	1600	2000	
• Up to 60 °C (Cu bare) ⁵⁾	A	1000	1250	1600	800	1000	1250	1600	2000	
• Up to 70 °C (Cu black painted) ⁵⁾	A	1000	1210	1490	800	1000	1250	1600	2000	
Rated rotor operational voltage U_{er}	V	2000	2000	2000	2000	2000	2000	2000	2000	2000
Power loss at I_n										
With 3-phase symmetrical load	W	100	105	150	40	45	80	85	180	
• Fixed-mounted circuit breakers	W	195	205	350	85	95	165	175	320	
• Withdrawable circuit breakers										
Operating times										
• Make-time	ms	35	35	35	35	35	35	35	35	35
• Opening time	ms	38	38	38	34	34	34	34	34	34
• Electrical make-time (through closing solenoid) ²⁾	ms	80	80	80	100	100	100	100	100	100
• Electrical opening time (through shunt release)	ms	73	73	73	73	73	73	73	73	73
• Electrical opening time (instant. undervoltage release)	ms	73	73	73	73	73	73	73	73	73
• Opening time due to ETU, instant. short-circuit release	ms	50 ¹⁾	50 ¹⁾	50 ¹⁾	50 ¹⁾	50 ¹⁾	50 ¹⁾	50 ¹⁾	50 ¹⁾	50 ¹⁾
Endurance										
• Mechanical (without maintenance)	Oper. cycles	10 000	10 000	10 000	10 000	10 000	10 000	10 000	10 000	10 000
• Mechanical (with maintenance) ³⁾	Oper. cycles	20 000	20 000	20 000	15 000	15 000	15 000	15 000	15 000	15 000
• Electrical (without maintenance)	Oper. cycles	10 000	10 000	10 000	7 500	7 500	7 500	7 500	7 500	7 500
• 1000 V version, electrical (without maintenance)	Oper. cycles	--	--	--	1 000	1 000	1 000	1 000	1 000	1 000
• 1150 V version, electrical (without maintenance)	Oper. cycles	--	--	--	500	500	500	500	500	500
• Electrical (with maintenance) ³⁾	Oper. cycles	20 000	20 000	20 000	15 000	15 000	15 000	15 000	15 000	15 000
Switching frequency										
• 690 V version	1/h	60	60	60	60	60	60	60	60	60
• 1000 V version	1/h	--	--	--	20	20	20	20	20	20
• 1150 V version	1/h	--	--	--	20	20	20	20	20	20
Minimum interval between tripping operation by solid-state release and next making operation of the circuit breaker (only with autom. mechanical resetting of the lockout device)	ms	80	80	80	80	80	80	80	80	80
Mounting position										
Degree of protection	IP20 without cabinet door, IP41 with door sealing frame, IP55 with cover									
Main conductor minimum cross-sections										
• Copper bars, bare	Units	1 x 60 x 10	2 x 40 x 10	2 x 50 x 10	1 x 50 x 10	1 x 60 x 10	2 x 40 x 10	2 x 50 x 10	3 x 50 x 10	
• Copper bars, painted black	Units	1 x 60 x 10	2 x 40 x 10	2 x 50 x 10	1 x 50 x 10	1 x 60 x 10	2 x 40 x 10	2 x 50 x 10	3 x 50 x 10	
Auxiliary conductors (Cu)										
Max. number of auxiliary conductors x cross-section (solid/stranded)	Standard connection = strain-relief clamp	2 x 0.5 mm ² (AWG 20) ... 2 x 1.5 mm ² (AWG 16); 1 x 2.5 mm ² (AWG 14)								
	• Without end sleeve	1 x 0.5 mm ² (AWG 20) ... 1 x 1.5 mm ² (AWG 16)								
	• With end sleeve acc. to DIN 46228 Part 2	2 x 0.5 mm ² (AWG 20) ... 2 x 1.5 mm ² (AWG 16)								
	• With twin end sleeve	2 x 0.5 mm ² (AWG 20) ... 2 x 1.5 mm ² (AWG 16)								
	Optional connection = tension spring	2 x 0.5 mm ² (AWG 20) ... 2 x 2.5 mm ² (AWG 14)								
	• Without end sleeve	2 x 0.5 mm ² (AWG 20) ... 2 x 1.5 mm ² (AWG 16)								
	• With end sleeve acc. to DIN 46228 Part 2	2 x 0.5 mm ² (AWG 20) ... 2 x 1.5 mm ² (AWG 16)								
Position indicator switches	Tension spring terminals	1 x 0.5 mm ² (AWG 20) ... 1 x 2.5 mm ² (AWG 14)								
Weights										
3-pole	• Fixed-mounted circuit breakers	kg	43	43	43	56	56	56	56	56
	• Withdrawable circuit breakers	kg	45	45	45	60	60	60	60	60
4-pole	• Guide frames	kg	25	25	25	31	31	31	31	31
	• Fixed-mounted circuit breakers	kg	50	50	50	67	67	67	67	67
	• Withdrawable circuit breakers	kg	54	54	54	72	72	72	72	72
	• Guide frames	kg	30	30	30	37	37	37	37	37

1) Opening time on instantaneous short-circuit release with ETU15B = 85 ms.
 2) Make-time through closing solenoid for synchronization purposes (short-time excited) 50 ms.

3) Maintenance means: replace main contact elements and arc chutes (see Operating Manual).

4) Use of releases from -20 °C.

5) ETU76B with graphics display can be used up to max. 55 °C.

3WL Air Circuit Breakers

3WL Air Circuit Breakers/Non-Automatic Air Circuit Breakers up to 6300 A (AC)

General data

Size	II			III		
Type	3WL12 25	3WL12 32	3WL12 40	3WL13 40	3WL13 50	3WL13 63
Rated current I_n at 40 °C, at 50/60 Hz						
Main conductor	A 2500	3200	4000	4000	5000	6300
N conductor (only on 4-pole versions)	A 2500	3200	4000	4000	5000	6300
Rated operational voltage U_o at 50/60 Hz (for 1000 V version see Catalog LV 1, "Options")	V AC ... 690/1000	... 690/1000	... 690	... 690/1000	... 690/1000	... 690/1000
Rated insulation voltage U_i	V AC 1000	1000	1000	1000	1000	1000
Rated impulse withstand voltage U_{imp}						
• Main current paths	kV 12	12	12	12	12	12
• Auxiliary circuits	kV 4	4	4	4	4	4
• Control circuits	kV 2.5	2.5	2.5	2.5	2.5	2.5
Isolating function acc. to EN 60947-2	Yes	Yes	Yes	Yes	Yes	Yes
Utilization categories	B (except switching capacity class DC)					
Permissible ambient temperature						
• During operation (in operation with LCD max. 55 °C) ⁴⁾	°C -25/+70	-25/+70	-25/+70	-25/+70	-25/+70	-25/+70
• During storage (special conditions for LCDs must be observed)	°C -40/+70	-40/+70	-40/+70	-40/+70	-40/+70	-40/+70
Permissible load⁶⁾						
• Up to 55 °C (Cu bare)	A 2500	3200	3950	4000	5000	5920
• Up to 60 °C (Cu bare) ⁵⁾	A 2500	3020	3810	4000	5000	5810
• Up to 70 °C (Cu black painted) ⁵⁾	A 2280	2870	3600	4000	5000	5500
Rated rotor operational voltage U_{er}	V 2000	2000	2000	2000	2000	2000
Power loss at I_n						
With 3-phase symmetrical load						
• Fixed-mounted circuit breakers	W 270	410	750	520	630	900
• Withdrawable circuit breakers	W 520	710	925	810	1050	1600
Operating times						
• Make-time	ms 35	35	35	35	35	35
• Opening time	ms 34	34	34	34	34	34
• Electrical make-time (through closing solenoid) ²⁾	ms 100	100	100	100	100	100
• Electrical opening time (through shunt release)	ms 73	73	73	73	73	73
• Electrical opening time (instantaneous undervoltage release)	ms 73	73	73	73	73	73
• Opening time due to ETU, instantaneous short-circuit release	ms 50 ¹⁾	50 ¹⁾	50 ¹⁾	50	50	50
Endurance						
• Mechanical (without maintenance)	Oper. cycles 10000	10000	10000	5000	5000	5000
• Mechanical (with maintenance) ³⁾	Oper. cycles 15000	15000	15000	10000	10000	10000
• Electrical (without maintenance)	Oper. cycles 7500	4000	4000	2000	2000	2000
• 1000 V version, electrical (without maintenance)	Oper. cycles 1000	1000	1000	1000	1000	1000
• 1150 V version, electrical ⁷⁾ (without maintenance)	Oper. cycles 500	500	500	1000	1000	1000
• Electrical (with maintenance) ³⁾	Oper. cycles 15000	15000	15000	10000	10000	10000
Switching frequency						
• 690 V version	1/h 60	60	60	60	60	60
• 1000 V version	1/h 20	20	20	20	20	20
• 1150 V version ⁷⁾	1/h 20	20	20	20	20	20
Minimum interval between tripping operation by solid-state release and next making operation of the circuit breaker (only with automatical mechanical resetting of the lockout device)	ms 80	80	80	80	80	80
Mounting position						
Degree of protection	IP20 without cabinet door, IP41 with door sealing frame, IP55 with cover					
Main conductor minimum cross-sections						
• Copper bars, bare	Units mm ² 2 x 100 x 10	3 x 100 x 10	4 x 120 x 10	4 x 100 x 10	6 x 100 x 10	6 x 120 x 10
• Copper bars, painted black	Units mm ² 2 x 100 x 10	3 x 100 x 10	4 x 100 x 10 ⁸⁾	4 x 100 x 10	6 x 100 x 10	6 x 120 x 10
Auxiliary conductors (Cu)						
Standard connection = strain-relief clamp						
• Without end sleeve	2 x 0.5 mm ² (AWG 20) ... 2 x 1.5 mm ² (AWG 16); 1 x 2.5 mm ² (AWG 14)					
• With end sleeve acc. to DIN 46228 Part 2	1 x 0.5 mm ² (AWG 20) ... 1 x 1.5 mm ² (AWG 16)					
• With twin end sleeve	2 x 0.5 mm ² (AWG 20) ... 2 x 1.5 mm ² (AWG 16)					
Optional connection = tension spring						
• Without end sleeve	2 x 0.5 mm ² (AWG 20) ... 2 x 2.5 mm ² (AWG 14)					
• With end sleeve acc. to DIN 46228 Part 2	2 x 0.5 mm ² (AWG 20) ... 2 x 1.5 mm ² (AWG 16)					
Position indicator switches	Tension spring terminals					
	1 x 0.5 mm ² (AWG 20) ... 1 x 2.5 mm ² (AWG 14)					
Weights 3-pole						
• Fixed-mounted circuit breakers	kg 59	64	85	82	82	90
• Withdrawable circuit breakers	kg 63	68	121	88	88	96
• Guide frames	kg 39	45	52	60	60	70
4-pole						
• Fixed-mounted circuit breakers	kg 71	77	103	99	99	108
• Withdrawable circuit breakers	kg 76	82	146	106	106	108
• Guide frames	kg 47	54	62	84	84	119

1) Opening time on instantaneous short-circuit release with ETU15B = 85 ms.

2) Make-time through closing solenoid for synchronization purposes (short-time excited) 50 ms.

3) Maintenance means: replace main contact elements and arc chutes (see Operating Manual).

4) Use of releases from -20 °C.

5) ETU76B with graphics display can be used up to max. 55 °C.

6) 4000 A, size II in fixed-mounted version, 3-pole.

7) Size III: data for very high switching capacity.

8) Minimum main conductor cross-sections for 4-pole withdrawable circuit breakers: 4 x 120 x 10 mm.

3WL Air Circuit Breakers

3WL Air Circuit Breakers/Non-Automatic Air Circuit Breakers up to 6300 A (AC)

General data

Size	I to III		
Type	3WL1		
Manual operating mechanism with mechanical closing			
Closing/ Charging stored-energy feature	Max. force required to operate the hand lever Required number of strokes on the hand lever	N	≤ 230 9
Manual operating mechanism with mechanical and electrical closing			
Charging stored-energy feature			
Closing solenoid (CC)	<ul style="list-style-type: none"> Operating range 		0.85 ... 1.1 × U_s
	<ul style="list-style-type: none"> Extended operating range for battery operation 	At 24 V DC, 48 V DC 60 V DC, 110 V DC 220 V DC	0.7 ... 1.26 × U_s
	<ul style="list-style-type: none"> Power consumption 	AC/DC	VAW 15/15
	<ul style="list-style-type: none"> Minimum command duration at U_s for the closing solenoid 		ms 60
	<ul style="list-style-type: none"> Short-circuit protection Smallest permissible DIAZED fuse (gL operational class)/ miniature circuit breaker with C characteristic 		1 A TDz (slow)/1 A
Manual/motorized operating mechanism with mechanical and electrical closing			
Manual operating mechanism			For data see above.
Motor	<ul style="list-style-type: none"> Operating range Extended operating range for battery operation 	At 24 V DC, 48 V DC 60 V DC, 110 V DC 220 V DC	0.85 ... 1.1 × U_s 0.7 ... 1.26 × U_s
	<ul style="list-style-type: none"> Power consumption of motor 	AC/DC	VAW 135/135
	<ul style="list-style-type: none"> Time required to charge the stored-energy mechanism at 1 × U_s 		s ≤ 10
Closing solenoid			For data see above.
For motor and closing solenoid	<ul style="list-style-type: none"> Short-circuit protection Smallest permissible DIAZED fuse (gL operational class)/ miniature circuit breaker with C characteristic; Motor and closing solenoid for the same rated control supply voltages 		2 A TDz (slow)/1 A
	<ul style="list-style-type: none"> Smallest permissible DIAZED fuse (gL operational class)/ miniature circuit breaker with C characteristic (for different rated control supply voltages) 	At $U_s = 24 \dots 30$ V At $U_s = 48 \dots 60$ V At $U_s = 110 \dots 125$ V DC/ 110 ... 127 V AC At $U_s = 220 \dots 250$ V DC/ 208 ... 240 V AC	2 A 2 A 1 A 1 A
Solid-state release signals			
Measuring accuracy of the solid-state release			Protection functions according to EN 60947; current indication ≤ 10 %; Measurement function base quantities ≤ 1 %; Measurement function derived quantities ≤ 4 %
Auxiliary releases			
Undervoltage releases UVR (F3) and UVR-t_d (F4)	<ul style="list-style-type: none"> Response values 	Pickup Dropout	≥ 0.85 × U_s (circuit breaker can be closed) 0.35 ... 0.7 × U_s (circuit breaker is tripped)
	<ul style="list-style-type: none"> Operating range 		0.85 ... 1.1
	<ul style="list-style-type: none"> Extended operating range for battery operation 	At 24 V DC, 30 V DC, 48 V DC, 110 V DC, 220 V DC	0.85 ... 1.26
	<ul style="list-style-type: none"> Rated control supply voltage U_s 	Instantaneous AC 50/60 Hz DC	V 110 ... 127/208 ... 240/380 ... 415 V 24/30/48/60/110/220 ... 250 ¹⁾
		Delayed AC 50/60 Hz DC	V 110 ... 127; 208 ... 240; 380 ... 415 V 48; 110 ... 125; 220 ... 250
	<ul style="list-style-type: none"> Power consumption (pickup/uninterrupted duty) 	AC DC	VA 20/5 W 20/5
	<ul style="list-style-type: none"> Opening time of circuit breaker at $U_s = 0$ 		ms 200
	<ul style="list-style-type: none"> - Version UVR (F3) 	Instantaneous With delay	ms 80 ms 200
	<ul style="list-style-type: none"> - Version UVR-t_d (F8) 	With delay, $t_d = 0.2$ to 3.2 s Reset through additional NC contact – direct switching off	s 0.2 ... 3.2 ms ≤ 100
	<ul style="list-style-type: none"> Short-circuit protection Smallest permissible DIAZED fuse (gL operational class)/ Miniature circuit breaker with C characteristic 		1 A TDz (slow) 1 A

1) 24 V and 30 V only with undervoltage release UVR (F3).

3WL Air Circuit Breakers

3WL Air Circuit Breakers/Non-Automatic Air Circuit Breakers up to 6300 A (AC)

General data

Size	I to III						
Type	3WL1						
Auxiliary releases							
Shunt release (ST) (F1, F2)	<ul style="list-style-type: none"> For continuous command (100 % ON period), locks out on momentary-contact commands 	- Response value	pickup	$> 0.7 \times U_s$ (circuit breaker is tripped)			
		- Operating range		$0.85 \dots 1.1 \times U_s$			
		- Extended operating range for battery operation	At 24 V DC, 48 V DC 60 V DC, 110 V DC 220 V DC		$0.7 \dots 1.26 \times U_s$		
		- Rated control supply voltage U_s	AC 50/60 Hz DC	V	110; 230 24; 30; 48; 60; 110; 220		
		- Power consumption	AC/DC	VA/W	15/15		
		- Minimum command duration at U_s		ms	60		
		- opening time of circuit breaker at $U_s = 100\%$	AC/DC	ms	80		
		- Short-circuit protection Smallest permissible DIAZED fuse (gL operational class)/ miniature circuit breaker with C characteristic			1 A TDz (slow)/1 A		
		5 % ON period		- Response value	Pickup	$> 0.7 \times U_s$ (circuit breaker is tripped)	
				- Operating range		$0.85 \dots 1.1 \times U_s$	
- Extended operating range for battery operation	At 24 V DC, 48 V DC 60 V DC, 110 V DC 220 V DC				$0.7 \dots 1.26 \times U_s$		
- Rated control supply voltage U_s	AC 50/60 Hz DC			V	110 ... 127; 208 ... 240 24; 48; 110 ... 125; 220 ... 250		
- Power consumption	AC/DC			VA/W	15/15		
- Minimum command duration at U_s				ms	25		
- Opening time of circuit breaker at $U_s = 100\%$	AC/DC			ms	50		
- Short-circuit protection Smallest permissible DIAZED fuse (gL operational class)/miniature circuit breaker with C characteristic					1 A TDz (slow)/1 A		
With stored energy feature consisting of shunt release and capacitor storage device				- Rated control supply voltage U_s	AC 50/60 Hz DC	V 110; 230 V 110; 220	
				- Operating range		$0.85 \dots 1.1 \times U_s$	
		- Power consumption	AC/DC	VA/W	1/1		
		- Storage time at U_s / recharging time at U_s			maximum 5 min/minimum 5 s		
		- Opening time of circuit breaker, short-circuit protection			As with "for continuous command"		
Remote reset solenoid for mechanical tripped indicator (F7)							
Remote reset solenoid for mechanical tripped indicator (F7)		- Operating range		$0.85 \dots 1.1 \times U_s$			
		- Extended operating range for battery operation	At 24 V DC, 48 V DC 110 V DC 220 V DC		$0.7 \dots 1.26 \times U_s$		
		- Power consumption	AC/DC	VA/W	50/50		
		- Minimum command duration at U_s for the remote reset solenoid		ms	60		
		- Short-circuit protection Smallest permissible DIAZED fuse (gL operational class)/ miniature circuit breaker with C characteristic			2 A TDz (slow)/1 A at 24 V DC and 48 V DC, 1 A TDz (slow)/1 A at 110 V and 208 ... 250 V		
Contact position-driven auxiliary switches (S1, S2, S3, S4, S7, S8)							
Rated insulation voltage U_i		V AC/DC	500				
Rated operational voltage U_e		V AC/DC	500				
Rated impulse withstand voltage U_{imp}		kV	4				
Switching capacity	• Alternating current 50/60 Hz	- Rated operational voltage U_e	V	24 ... 230	380/400	500	
		- Rated operational current I_e /AC-12	A	10	10	10	
		I_e /AC-15	A	4	3	2	
	• Direct current	- Rated operational voltage U_e	V	24	48	110	220
		- Rated operational current I_e /DC-12	A	10	8	3.5	1
		I_e /DC-13	A	8	4	1.2	0.4
Short-circuit protection	<ul style="list-style-type: none"> Largest permissible DIAZED fuse (gL operational class) Largest permissible miniature circuit breaker with C characteristic 			10 A TDz, 10 A Dz 10 A			

3WL Air Circuit Breakers

3WL Air Circuit Breakers/Non-Automatic Air Circuit Breakers up to 6300 A (AC)

General data

Size				I to III
Type				3WL1
Ready-to-close signaling switch (S20) (acc. to DIN VDE 0630)				
Switching capacity	• Alternating current	- Rated operational voltage U_e	V	250
		- Rated operational current I_e	A	8
• Direct current	- Rated operational voltage U_e	V	125	250
	- Rated operational current I_e	A	0.4	0.2
Short-circuit protection	Largest permissible DIAZED fuse (gL operational class)			2 A Dz (quick)
Tripped signal switch (S24) and signal switch for auxiliary releases (S22, S23) (acc. to DIN VDE 0630)				
Switching capacity	• Alternating current	- Rated operational voltage U_e	V	250
		- Rated operational current $I_e/AC-12$	A	8
• Direct current	- Rated operational voltage U_e	V	24	125
	- Rated operational current $I_e/DC-12$	A	6	0.4
Short-circuit protection	Largest permissible DIAZED fuse (gL operational class)			6 A Dz (quick)
Tripped signal switch	Signal duration after tripping			Until manual or electrical remote reset (option)
Position indicator switch on guide frame				
Type of contact	• Signal:	- "Circuit breaker in connected position"	3 CO	1 CO
		- "Circuit breaker in test position"	2 CO	1 CO
		- "Circuit breaker in disconnected position"	1 CO	1 CO
			or	
Rated insulation voltage U_i		AC 50/60 Hz	V	440
		DC	V	250
Rated operational voltage U_e				V 250
Rated impulse withstand voltage U_{imp}				kV 4
Switching capacity	• Rated operational current I_e	- $I_e/AC-12$	24 V 10 A, 110/127 V 10 A, 220/240 V 10 A, 320/440 V 10 A	
		- $I_e/AC-15$	220/240 V 4 A, 320/440 V 3 A,	
		- $I_e/DC-12$	24 V 10 A, 48 V 2.5 A, 220/240 V 0.2 A,	
		- $I_e/DC-13$	24 V 3.0 A, 220/240 V 0.1 A	
		- A 300 (AC)	120 V 6 A, 240 V 3 A	
		- R 300 (DC)	125 V 0.22 A, 250 V 0.11 A	
Short-circuit protection	• Largest permissible DIAZED fuse (gL operational class)			8 A TDz (slow)
	• Largest permissible miniature circuit breaker with C characteristic			8 A TDz (slow)

3WL Air Circuit Breakers

3WL Air Circuit Breakers/Non-Automatic Air Circuit Breakers up to 6300 A (AC)

General data

Protection functions Parameterization by	ETU15B D	ETU25B D	ETU27B D & S	
Functional overview of the solid-state release system				
<p>NSE0_00888b</p>	Overload protection Function can be switched on/off Setting range $I_R = I_n \times \dots$	✓ --	✓ --	
	L Switchable overload protection (I^2t - or I^4t -dependent function) Setting range for time-lag class t_R at I^2t Setting range for time-lag class t_R at I^4t Thermal image can be switched on/off Phase failure sensitivity	-- 10 s fixed -- --	-- 10 s fixed -- --	-- 10 s fixed -- --
	N Neutral conductor protection Function can be switched on/off N conductor setting range $I_N = I_n \times \dots$	-- --	-- --	✓ ✓
	S Short-time delayed short-circuit protection Function can be switched on/off Setting range $I_{sd} = I_n \times \dots$ Setting range for delay time t_{sd} Switchable short-time delayed short-circuit protection (I^2t -dependent function) Setting range for delay time t_{sg} at I^2t Zone Selective Interlocking function	-- -- -- --	✓ 1.25-1.5-2-2.5-3-4-6-8-10-12 0-M-100-200-300-400 ms --	✓ 1.25-1.5-2-2.5-3-4-6-8-10-12 0-M-100-200-300-400 ms --
	I Instantaneous short-circuit protection Function can be switched on/off Setting range $I_i = I_n \times \dots$	✓ 2-3-4-5-6-7-8	✓ Fixed for $I_i \geq 20 \times I_n$, max. 50 kA	✓ Fixed for $I_i \geq 20 \times I_n$, max. 50 kA ✓ Fixed mounted
	G Ground-fault protection Tripping and alarm function Tripping function can be switched on/off Alarm function can be switched on/off Detection of the ground-fault current through summation current formation with internal or external neutral conductor transformer Detection of ground-fault current through external current transformer Setting range of the operating current I_g for release Setting range of the operating current I_g for alarm Setting range of the delay time t_g Switchable ground-fault protection characteristic curve (I^2t -dependent function) Setting range for delay time t_g at I^2t Zone Selective Interlocking ground-fault protect. func.	-- -- -- -- -- -- -- -- --	-- -- -- -- -- -- -- -- --	-- -- ✓ ✓ A-B-C-D-E -- 100-200-300-400-500 ms -- -- --
	Parameter set switchover Switchable between parameter set A and B	--	--	--
	LCD Alphanumeric LCD (4-line) Graphical LCD (24 V, ext. power supply required)	-- --	-- --	-- --
	Communication CubicleBUS integrated Communication-capable through PROFIBUS DP	-- --	-- --	-- --
	Measurement function Measurement-function capable with measurement function <i>Plus</i>	--	--	--
LED display Solid-state release active Alarm ETU fault L-release S-release I-release N-release G-release G-alarm Release through extended protection function Communication	✓ ✓ ✓ -- -- -- -- -- -- -- -- -- -- --	✓ ✓ ✓ ✓ ✓ ✓ -- -- -- -- -- -- -- --	✓ ✓ ✓ ✓ ✓ ✓ ✓ -- -- -- -- -- -- --	
Signals from signal switches with external CubicleBUS modules (relays) Overload warning Load shedding, load receiving Leading signal overload trip 200 ms Temperature alarm Phase unbalance Instantaneous short-circuit release Short-time delayed short-circuit release Overload trip Neutral conductor release Ground-fault protection release Ground-fault alarm Auxiliary relay ETU fault	-- -- -- -- -- -- -- -- -- -- -- -- -- -- -- -- -- -- -- --	-- -- -- -- -- -- -- -- -- -- -- -- -- -- -- -- -- -- -- --	-- -- -- -- -- -- -- -- -- -- -- -- -- -- -- -- -- -- -- --	

Delay time figures given in ms.
 M = Motor protection, corresponds to 20 ms.
 D = Rotary coding switch
 D & S = Rotary coding and slide switch
 K = Communication
 M/K = Menu/communication

✓ Available
 -- Not available
 □ Optional

For the setting range of the operating current I_g see page 15/31.

3WL Air Circuit Breakers

3WL Air Circuit Breakers/Non-Automatic Air Circuit Breakers up to 6300 A (AC)

General data

Protection functions Parameterization by	ETU45B D & S	ETU76B M/K
Functional overview of the solid-state release system		
Overload protection	✓	✓
Function can be switched on/off	--	✓
Setting range $I_R = I_n \times \dots$	0.4-0.45-0.5-0.55-0.6- 0.65-0.7-0.8-0.9-1	0.4 ... 1
Switchable overload protection (I^2t - or I^4t -dependent function)	✓	✓
Setting range for time-lag class t_R at I^2t	2-3.5-5.5-8-10-14-17-21-25-30 s	2 ... 30 s
Setting range for time-lag class t_R at I^4t	1-2-3-4-5 s	1 ... 5 s
Thermal image can be switched on/off	✓	✓
Phase failure sensitivity	At $t_{sd} = 20$ ms (M)	✓ (on/off)
Neutral conductor protection	✓	✓
Function can be switched on/off	✓	✓
N conductor setting range $I_N = I_n \times \dots$	0.5 ... 1	0.2 ... 2
Short-time delayed short-circuit protection	✓	✓
Function can be switched on/off	✓	✓
Setting range $I_{sd} = I_n \times \dots$	1.25-1.5-2-2.5-3-4-6-8-10-12	$1.25 \times I_n \dots 0.8 \times I_{cw}$
Setting range for delay time t_{sd}	M-100-200-300-400 ms	M-80 ... 4000 ms
Switchable short-time delayed short-circuit protection (I^2t -dependent function)	✓	✓
Setting range for delay time t_{sd} at I^2t	100-200-300-400 ms	100 ... 400 ms
Zone Selective Interlocking function	By CubicleBUS -Modul	By CubicleBUS -Modul
Instantaneous short-circuit protection	✓	✓
Function can be switched on/off	✓	✓
Setting range $I_I = I_n \times \dots$	1.5-2.2-3-4-6-8-10-12-0.8 $\times I_{cs}$	$1.5 \times I_n \dots 0.8 \times I_{cs}$
Ground-fault protection	<input type="checkbox"/> Module can be retrofitted	<input type="checkbox"/> Module can be retrofitted
Tripping and alarm function	✓	✓
Tripping function can be switched on/off	✓	✓
Alarm function can be switched on/off	--	✓
Detection of the ground-fault current through summation current formation with int. or ext. neutral conductor transformer	✓	✓
Detection of ground-fault current through external current transformer	✓	✓
Setting range of the operating current I_g for release	A-B-C-D-E	A ... E
Setting range of the operating current I_a for alarm	A-B-C-D-E	A ... E
Setting range of the delay time t_g	100-200-300-400-500 ms	100 ... 500 ms
Switchable ground-fault protection characteristic curve (I^2t -dependent function)	✓	✓
Setting range for delay time t_g at I^2t	100-200-300-400-500 ms	100 ... 500 ms
Zone Selective Interlocking ground-fault protect. function	By CubicleBUS -Modul	By CubicleBUS -Modul
Parameter set switchover		
Switchable between parameter set A and B	--	✓
LCD		
Alphanumeric LCD (4-line)	<input type="checkbox"/>	--
Graphical LCD (24 V, external power supply required)	--	✓
Communication		
CubicleBUS integrated	✓	✓
Communication-capable through PROFIBUS DP	✓	✓
Measurement function		
Measurement-function capable with measurement function <i>Plus</i>	✓	✓
LED display		
Solid-state release active	✓	✓
Alarm	✓	✓
ETU fault	✓	✓
L-release	✓	✓
S-release	✓	✓
I-release	✓	✓
N-release	✓	✓
G-release	✓ (only with ground-fault prot. module)	✓ (only with ground-fault prot. module)
G-alarm	✓ (only with ground-fault prot. module)	✓ (only with ground-fault prot. module)
Release through extended protection functions	✓	✓
Communication	✓	✓
Signals from signal switches with external CubicleBUS modules (relays)		
Overload warning	✓	✓
Load shedding, load receiving	✓	✓
Leading signal overload trip 200 ms	✓	✓
Temperature alarm	✓	✓
Phase unbalance	✓	✓
Instantaneous short-circuit release	✓	✓
Short-time delayed short-circuit release	✓	✓
Overload trip	✓	✓
Neutral conductor release	✓	✓
Ground-fault protection release	✓ (only with ground-fault prot. module)	✓ (only with ground-fault prot. module)
Ground-fault alarm	✓ (only with ground-fault prot. module)	✓ (only with ground-fault prot. module)
Auxiliary relay	✓	✓
ETU fault	✓	✓

Setting range of the operating current I_g	Size III	
	Size I and size II	Size III
A	100 A	400 A
B	300 A	600 A
C	600 A	800 A
D	900 A	1000 A
E	1200 A	1200 A

Increment size for adjustment of M			
From ... to	Increment size	From ... to	Increment size
0 ... 1	0.1	1000 ... 1600	50
1 ... 100	1	1600 ... 10000	100
100 ... 500	5	10000 ... max	1000
500 ... 1000	10		

For continuation of legend see page 15/30.

3WL Air Circuit Breakers

3WL Air Circuit Breakers/Non-Automatic Air Circuit Breakers up to 6300 A (AC)

Project planning aids

Characteristic curves

Every solid-state release type and every setting has its own characteristic curve. Only a selection is shown in the following. The characteristic curves each show the largest and smallest setting range of SENTRON 3WL circuit breakers with 1000 A rated current at 500 V rated voltage with various releases. In order to obtain a complete tripping characteristic, the relevant parts of the characteristics have to be combined.

The characteristic curves show the behavior of the solid-state release when it is activated by a current that is already flowing before the tripping operation. If the overcurrent tripping occurs immediately after switch on and the solid-state release is therefore not yet enabled, the opening time is extended, depending on the level of the overcurrent by up to 15 ms. In order to determine the break-times of the circuit breakers, approximately 15 ms must be added to the opening times shown for the arcing time.²⁾

Refer to the following legend for tolerances.

The characteristic curves shown apply to ambient temperatures at the circuit breaker between -5 and +55 °C. The release can be operated at ambient temperatures of -20 to +70 °C. An extended tolerance band can apply at these temperatures.

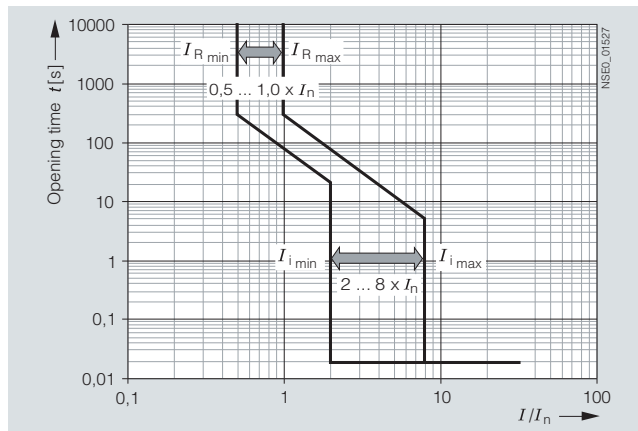

SENTRON 3WL circuit breaker with ETU15B solid-state release

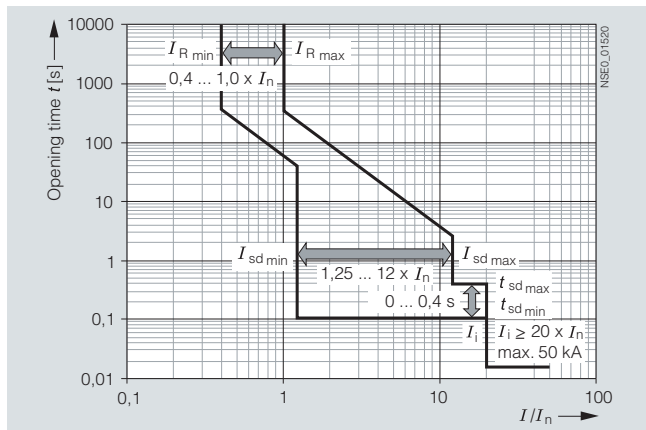

SENTRON 3WL circuit breaker with ETU25B solid-state release, LSI characteristic curve

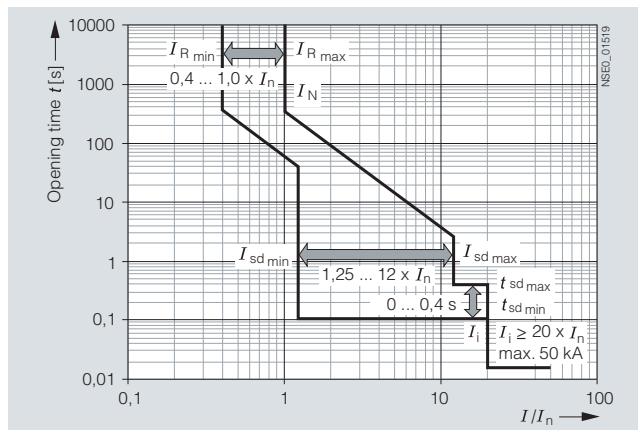

SENTRON 3WL circuit breaker with ETU27B solid-state release, LSIN characteristic curve

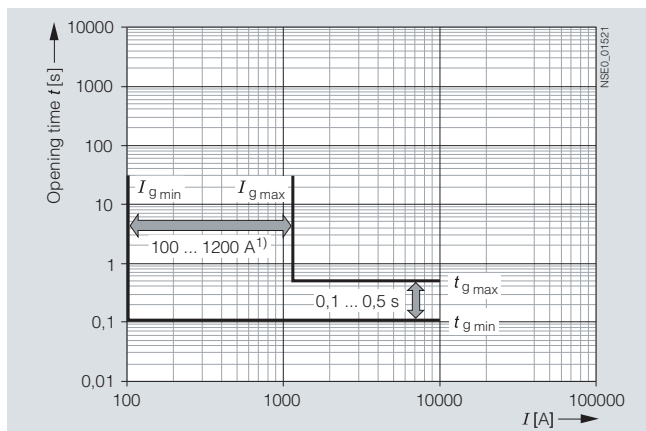

SENTRON 3WL circuit breaker with ETU27B solid-state release, G characteristic curve

Tolerances for the set currents

- L: tripping operations between 1.05 and 1.2 x I_R
- S: -0 %, +20 %
- I: -0 %, +20 %
- G: -0 %, +20 %

Tolerances for the tripping times

- L: -20 %, +0 % for I^2t characteristic curve
- S: -0 %, +60 ms or -0 %, 10 % for tripping times greater than 600 ms
- I: < 50 ms
- G: -0 %, +60 ms or -0 %, 10 % for tripping times greater than 600 ms

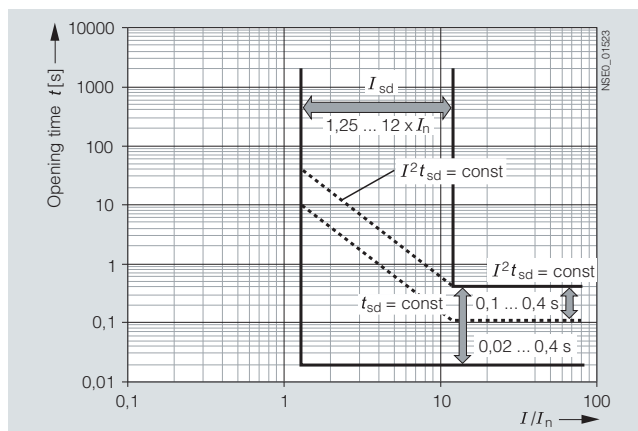

SENTRON 3WL circuit breaker with ETU45B solid-state release, S characteristic curve

1) Sizes I and II: 100 ... 1200 A
Size III: 400 ... 1200 A.

2) With single-pole loading in the lowest rated current range, the response times of the short-circuit release can be extended by approx. 10 % and the tripping times by approx. 15 % compared to the characteristic curve.

3WL Air Circuit Breakers/Non-Automatic Air Circuit Breakers up to 6300 A (AC)

Project planning aids

Every solid-state release type and every setting has its own characteristic curve. Only a selection is shown in the following. The characteristic curves each show the largest and smallest setting range of SENTRON 3WL circuit breakers with 1000 A rated current at 500 V rated voltage with various releases. In order to obtain a complete tripping characteristic, the relevant parts of the characteristics have to be combined.

The characteristic curves show the behavior of the solid-state release when it is activated by a current that is already flowing before the tripping operation. If the overcurrent tripping occurs immediately after switch on and the solid-state release is therefore not yet enabled, the opening time is extended, depending on the level of the overcurrent by up to 15 ms. In order to determine the break-times of the circuit breakers, approximately 15 ms must be added to the opening times shown for the arcing time.²⁾

Refer to the following table for tolerances.

The characteristic curves shown apply to ambient temperatures at the circuit breaker between -5 and +55 °C. The release can be operated at ambient temperatures of -20 to +70 °C (ETU76B with graphics display up to +55 °C). An extended tolerance band can apply at these temperatures.

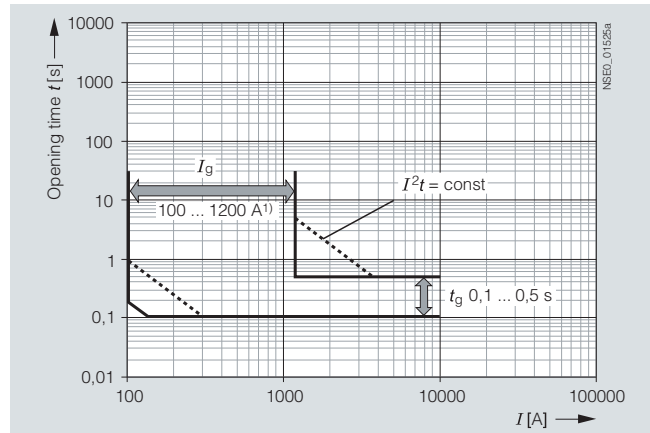

SENTRON 3WL circuit breaker with ETU45B and ETU76B solid-state release, G characteristic curve

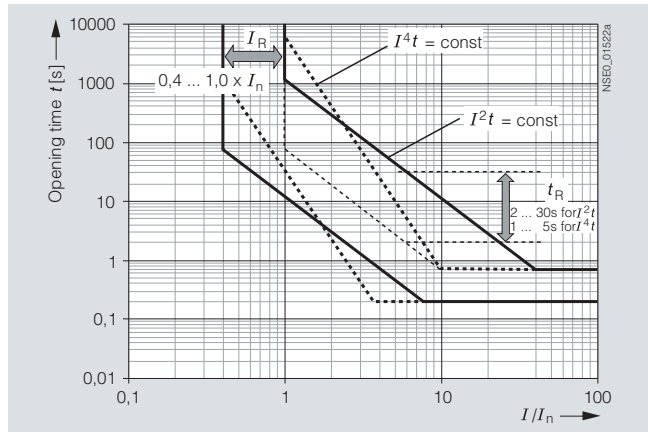

SENTRON 3WL circuit breaker with ETU45B and ETU76B solid-state release, L characteristic curve

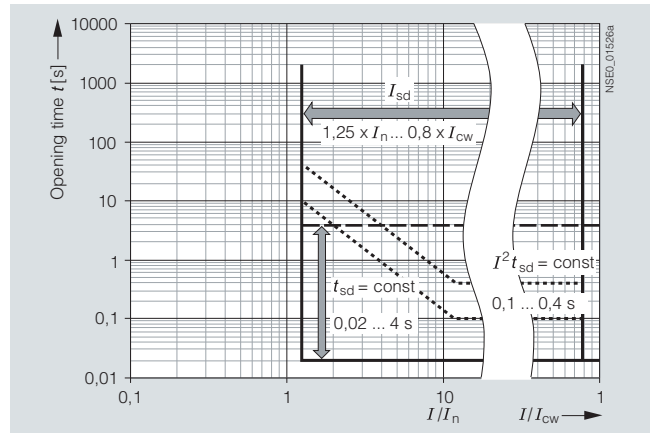

SENTRON 3WL circuit breaker with ETU76B solid-state release, S characteristic curve

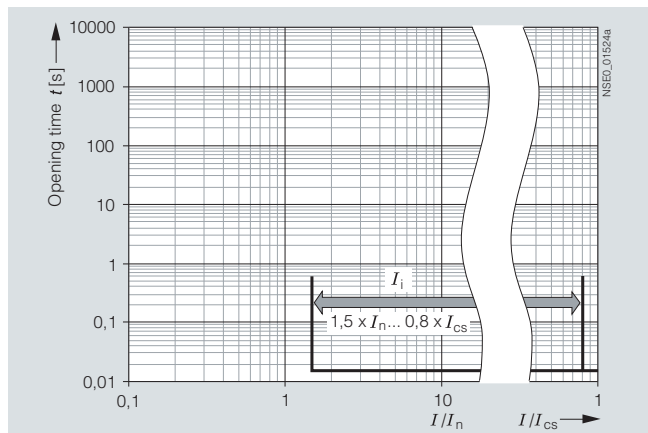

SENTRON 3WL circuit breaker with ETU45B and ETU76B solid-state release, I characteristic curve

Further characteristic curves are shown in the manual and the planning and configuring tool SIMARIS deSign, or ask your Siemens contact person.

Tolerances for the set currents

L: tripping operations between 1.05 and 1.2 × I_R

S: -0 %, +20 %

I: -0 %, +20 %

G: -0 %, +20 %

Tolerances for the tripping times

L: -20 %, +0 % for I²t characteristic curve

S: -0 %, +60 ms or -0 %, 10 % for tripping times greater than 600 ms

I: < 50 ms

G: -0 %, +60 ms or -0 %, 10 % for tripping times greater than 600 ms

1) Sizes I and II: 100 ... 1200 A
Size III: 400 ... 1200 A.

2) With single-pole loading in the lowest rated current range, the response times of the short-circuit release can be extended by approx. 10 % and the tripping times by approx. 15 % compared to the characteristic curve.

3WL Air Circuit Breakers

3WL Air Circuit Breakers/Non-Automatic Air Circuit Breakers up to 6300 A (AC)

Project planning aids

Dimensional drawings

Voltage transformer for SENTRON 3WL

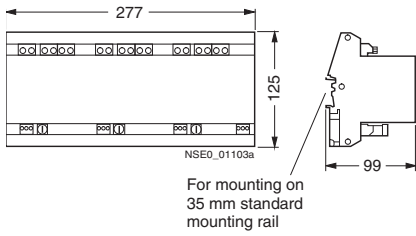

Current transformers for overload protection in the N conductor

External current transformers for N conductor with copper connection pieces

Size I, 3WL9 111-0AA31-0AA0

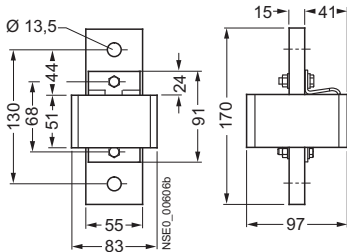

Size II, 3WL9 111-0AA32-0AA0

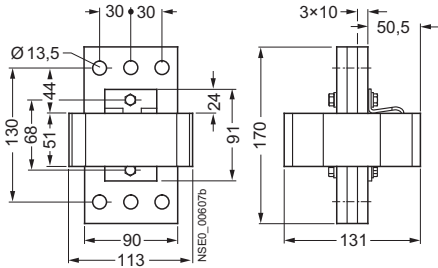

Size III, 3WL9 111-0AA33-0AA0

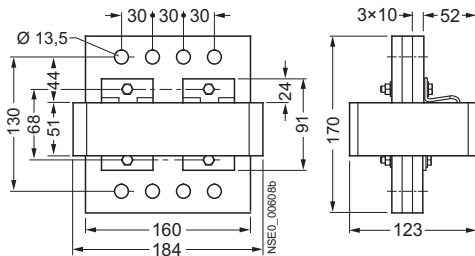

External current transformers for N conductor without copper connection pieces

Size I, 3WL9 111-0AA21-0AA0

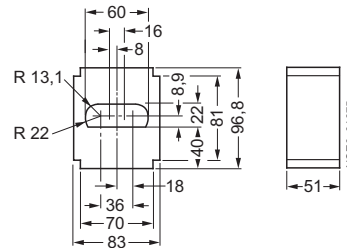

Size II, 3WL9 111-0AA22-0AA0

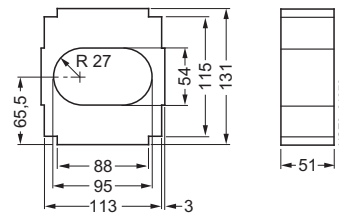

Size III, 3WL9 111-0AA23-0AA0

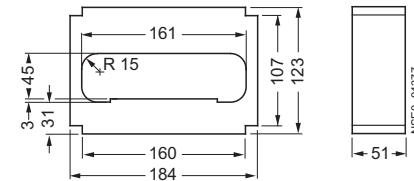

Door cut-out for operator panel

Door cut-out with edge protector

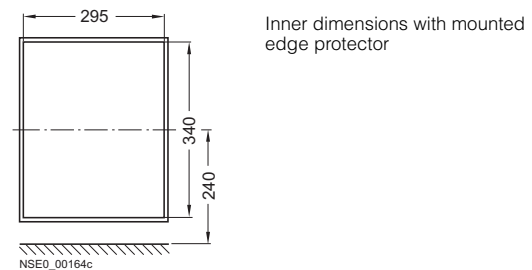

Door cut-out for operator panel using the door sealing frame

Option with/without door interlocking

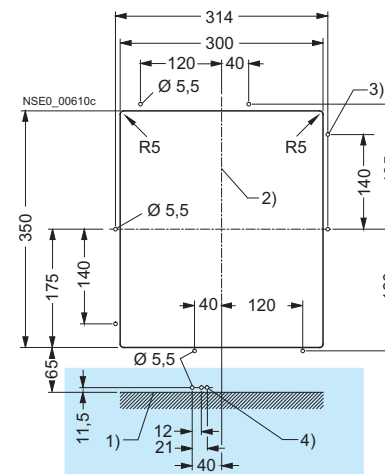

■ Dimensions for option with door interlocking

- 1) Mounting surface
- 2) Center SENTRON 3WL operator panel
- 3) 8 mounting holes for door sealing frame
- 4) 3 mounting holes for door interlocking

3WL Air Circuit Breakers

3WL Air Circuit Breakers/Non-Automatic Air Circuit Breakers up to 6300 A (AC)

Project planning aids

CubicleBUS module

3WL9 111-0AT2-0AA0

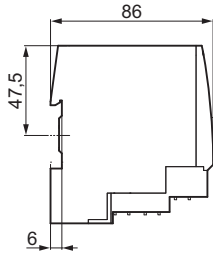
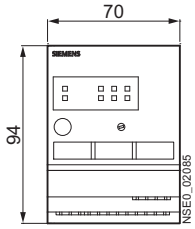

Breaker Data Adapter (BDA)

3WL9 111-0AT28-0AA0

3WL9 111-0AT33-0AA0

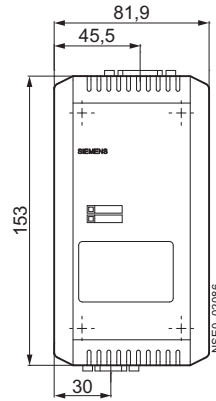

3WL Air Circuit Breakers

3WL Air Circuit Breakers/Non-Automatic Air Circuit Breakers up to 6300 A (AC)

Project planning aids

Door cut-out for operator panel using protective cover IP55

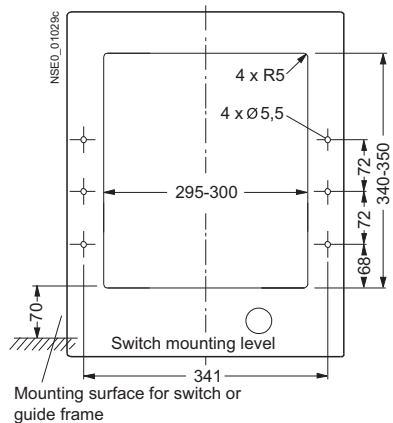

Protective cover, IP55

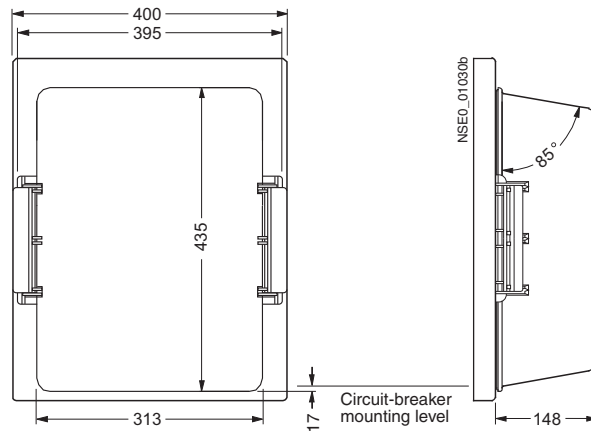

Safety clearances from grounded parts

Rated operational voltage V/AC	Above auxiliary connector mm	Lateral (each side) mm	Rear mm
Size I, fixed-mounted version			
500	75 ¹⁾	0	0
690	75 ¹⁾	0	0
Size I, withdrawable version, without arc chute cover			
500	50 ¹⁾	0	0
690	50 ¹⁾	0	0
Size I, withdrawable version, with arc chute cover			
500	0	0 ²⁾	0
690	0	0 ²⁾	0
Size II, fixed-mounted version			
500	75 ¹⁾	0	0
690	75 ¹⁾	0	0
1000	180	0	0
Size II, withdrawable version, without arc chute cover			
500	50 ¹⁾	0	0
690	50 ¹⁾	0	0
1000	100	0	0
Size II, withdrawable version, with arc chute cover			
500	0	0 ²⁾	0
690	0	0 ²⁾	0
Size III, fixed-mounted version			
500	75 ¹⁾	0	0
690	75 ¹⁾	0	0
1000	180	0	0
Size III, withdrawable version, without arc chute cover			
500	50 ¹⁾	0	0
690	50 ¹⁾	0	0
1000	100	0	0
Size III, withdrawable version, with arc chute cover			
500	0	0 ²⁾	0
690	0	0 ²⁾	0
DC non-automatic air circuit breakers			
300	45	0	0
600	200	0	0
1000	150	0	0

Safety clearances from live parts

Rated operational voltage V/AC	Above auxiliary connector mm	Lateral (each side) mm	Rear mm
Size I, fixed-mounted version			
500	150	20	20
690	300	50	125
Size I, withdrawable version, without arc chute cover			
500	150	20	14
690	300	50	14
Size I, withdrawable version, with arc chute cover			
500	14	100	14
690	14	100	14
Size II, fixed-mounted version			
500	250	50	20
690	600	100	140
1000	430	100	125
Size II, withdrawable version, without arc chute cover			
500	250	50	14
690	600	100	30
1000	350	100	14
Size II, withdrawable version, with arc chute cover			
500	14	50	14
690	14	225	14
Size III, fixed-mounted version			
500	75	20	20
690	500	100	125
1000	430	100	125
Size III, withdrawable version, without arc chute cover			
500	50	20	14
690	500	100	14
1000	350	100	14
Size III, withdrawable version, with arc chute cover			
500	14	50	14
690	14	200	14

1) Value for plate; 0 mm for struts and grids.

2) 40 mm (size II: 70 mm) for plates which cover the lateral openings in the guide frame.

All safety clearances above the circuit breaker refer to the upper edge of the auxiliary connector - not to the upper edge of the arc chute! See dimensional drawings on pages 15/37 to 15/45, parts 4) and 5).

Size I, up to 1600 A, fixed-mounted version, 3- and 4-pole

Standard version Horizontal connection

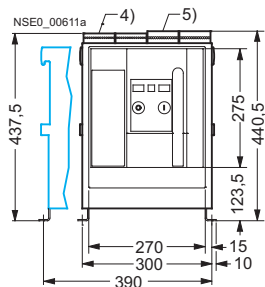

Optional connection variants Front connection (single)

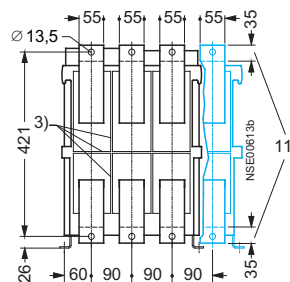
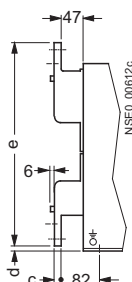

Front connection (double hole) according to DIN 43673

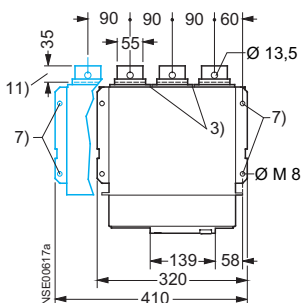
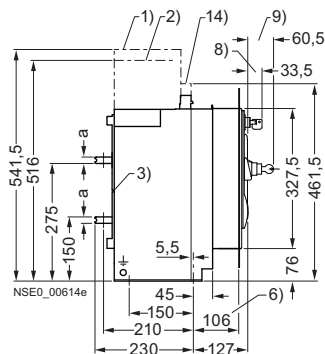
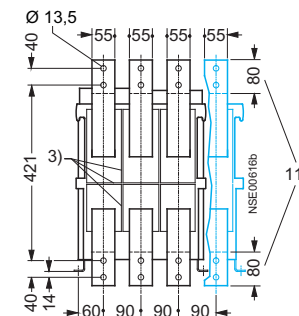
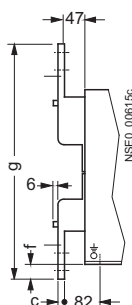

Vertical connection

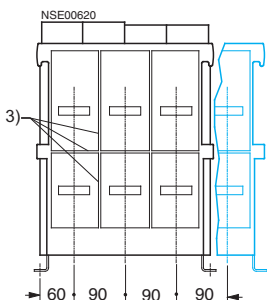
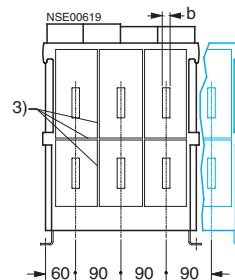
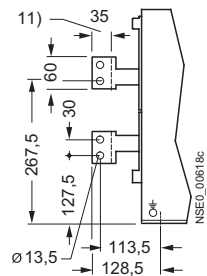

4-pole version

- 1) Mounting space for removal of the arc chutes.
- 2) Arc quenching space.
- 3) Grooves (4 mm wide, 5 mm deep) for supporting phase barriers in the system.
- 4) Auxiliary connector with SIGUT screw terminals.
- 5) Auxiliary connector with spring-loaded connection.
- 6) Dimension to inside surface of the closed cabinet door.
- 7) Fixing points for mounting the circuit breaker in the system.
- 8) "Secure OFF" locking device.
- 9) Key operation.
- 11) Terminal face.
- 14) Space for electrical auxiliary circuit connections.

9) Key operation.

11) Terminal face.

14) Space for electrical auxiliary circuit connections.

Rated circuit breaker current	a	b	c	d	e	f	g
A							
Up to 1000	10	10	10	11	451	34	541
1250 ... 1600	15	15	15	6	461	39	551

For safety clearances to grounded parts and to live parts see page 15/36.

3WL Air Circuit Breakers

3WL Air Circuit Breakers/Non-Automatic Air Circuit Breakers up to 6300 A (AC)

Project planning aids

Size I, up to 1600 A, 3- and 4-pole, withdrawable version

Standard version Horizontal connection

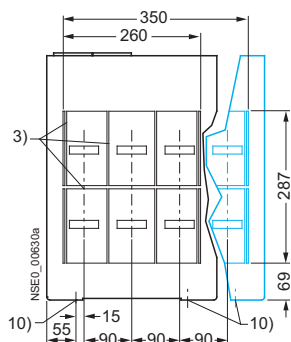
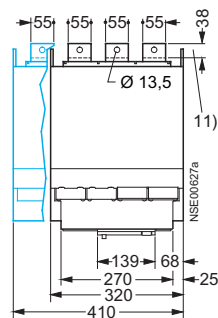
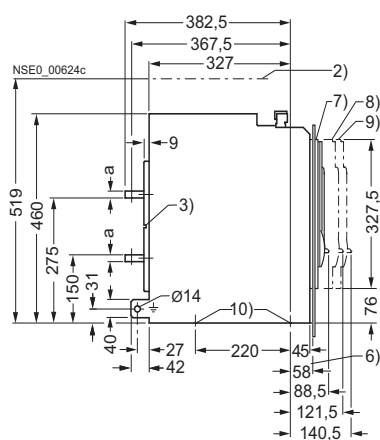
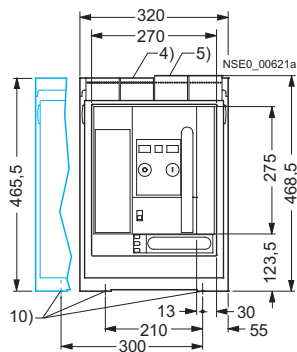

Optional connection variants Front connection (single)

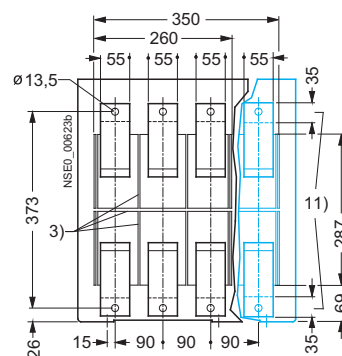
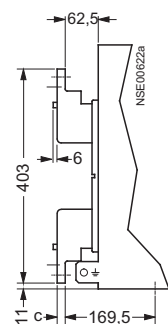

Front connection (double hole) according to DIN 43673

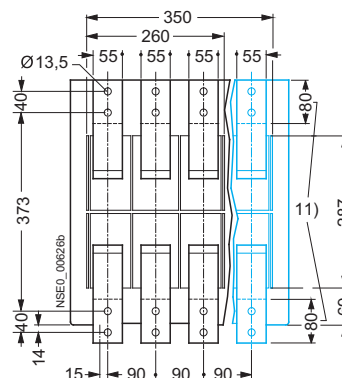
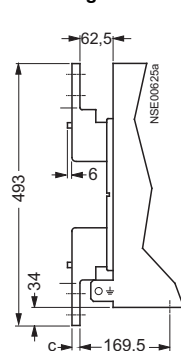

Vertical connection

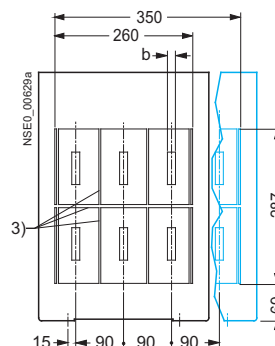
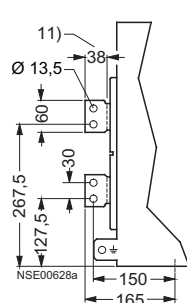

4-pole version

- 2) For guide frame without arc chute cover, arc quenching space facing grounded or non-conductive surfaces.
- 3) Grooves (4 mm wide, 5 mm deep) for supporting phase barriers in the system.
- 4) Auxiliary connector with SIGUT screw terminals.
- 5) Auxiliary connector with spring-loaded connection.
- 6) Dimension to inside surface of the closed cabinet door.
- 7) SENTRON 3WL in connected position.
- 8) SENTRON 3WL in test position.
- 9) SENTRON 3WL in disconnected position.
- 10) Fixing holes 10 mm.
- 11) Terminal face.

Rated circuit breaker current A	a	b	c
Up to 1000	10	10	10
1250 ... 1600	15	15	15

For safety clearances to grounded parts and to live parts see page 15/36.

For flange connections see following page.

3WL Air Circuit Breakers

3WL Air Circuit Breakers/Non-Automatic Air Circuit Breakers up to 6300 A (AC)

Project planning aids

Size I, up to 1600 A, withdrawable version, 3- and 4-pole

Flange connection

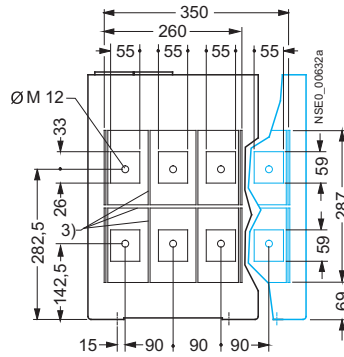
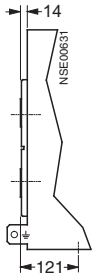

3) Grooves (4 mm wide, 5 mm deep) for supporting phase barriers in the system.

For safety clearances to grounded parts and to live parts see page 15/36.

For more connection options see previous page.

3WL Air Circuit Breakers

3WL Air Circuit Breakers/Non-Automatic Air Circuit Breakers up to 6300 A (AC)

Project planning aids

Size II, up to 4000 A, fixed-mounted version, 3- and 4-pole

Standard version
Horizontal connection

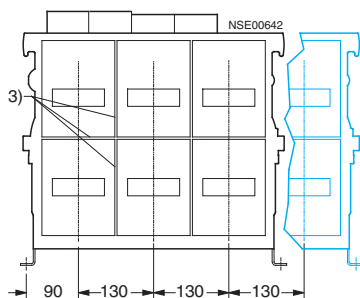
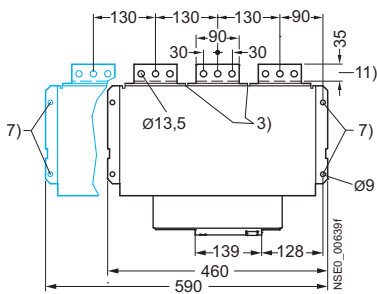
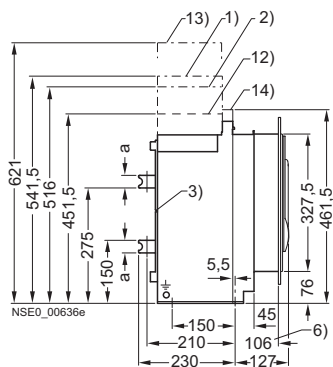
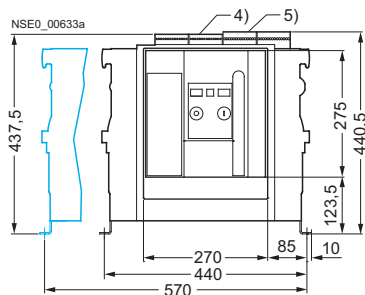

Optional connection variants
Front connection (single)

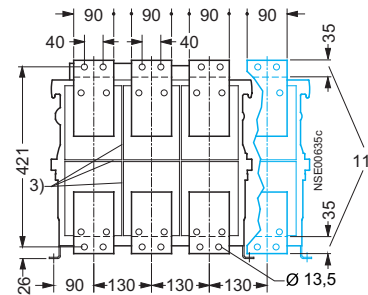
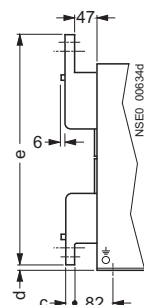

Front connection (double hole)
according to DIN 43673

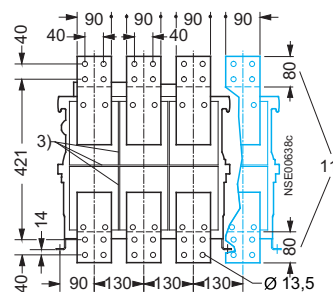
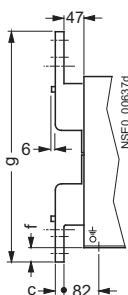

Vertical connection, up to 3200 A

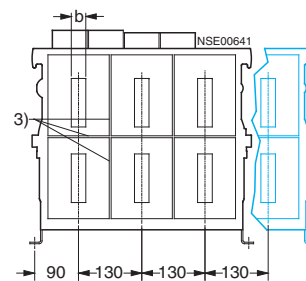
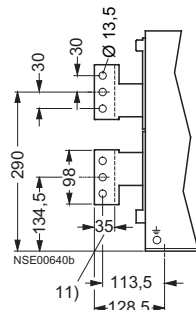

— 4-pole version

- 1) Mounting space for removal of the arc chutes.
- 2) Arc quenching space, "≤ 690 V" circuit breaker facing grounded or non-conductive surfaces.
- 3) Grooves (4 mm wide, 5 mm deep) for supporting phase barriers in the system.
- 4) Auxiliary connector with SIGUT screw terminals.
- 5) Auxiliary connector with spring-loaded connection.
- 6) Dimension to inside surface of the closed cabinet door.
- 7) Fixing points for mounting the circuit breaker in the system.
- 11) Terminal face.
- 12) Circuit breaker upper edge, only 1000 V circuit breaker.
- 13) Arc quenching space, 1000 V circuit breaker facing grounded or non-conductive surfaces.
- 14) Space for electrical auxiliary circuit connections.

Rated circuit breaker current A	a	b	c	d	e	f	g
Up to 2000	10	10	10	11	451	34	541
2500	15	15	20	6	461	39	551
3200/4000	30	30	20	6	461	39	551

For safety clearances to grounded parts and to live parts see page 15/36.
For flange connections see following page.

3WL Air Circuit Breakers

3WL Air Circuit Breakers/Non-Automatic Air Circuit Breakers up to 6300 A (AC)

Project planning aids

Size II, up to 4000 A, fixed-mounted version, 3- and 4-pole

Vertical connection 4000 A

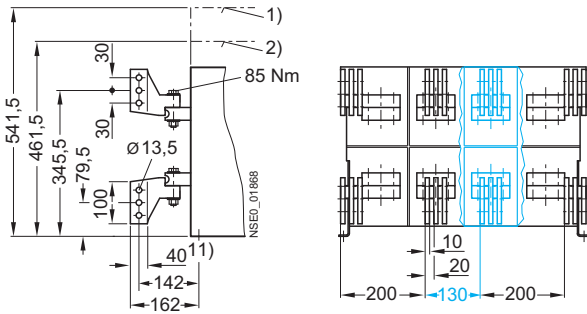

- 1) Mounting space for removal of the arc chutes.
- 2) Arc quenching space, " ≤ 690 V" circuit breaker facing grounded or non-conductive surfaces.
- 11) Terminal face.

For safety clearances to grounded parts and to live parts see page 15/36.

For more connection options see previous page.

3WL Air Circuit Breakers

3WL Air Circuit Breakers/Non-Automatic Air Circuit Breakers up to 6300 A (AC)

Project planning aids

Size II, up to 3200 A, withdrawable version, 3- and 4-pole

Standard version
Horizontal connection

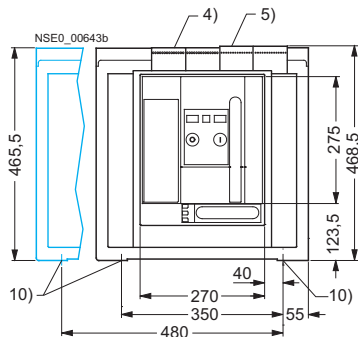

Optional connection variants
Front connection (single)

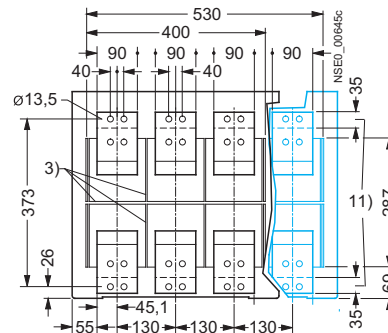
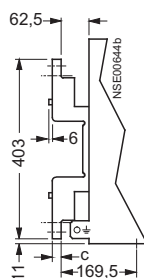

Front connection (double hole)
according to DIN 43673

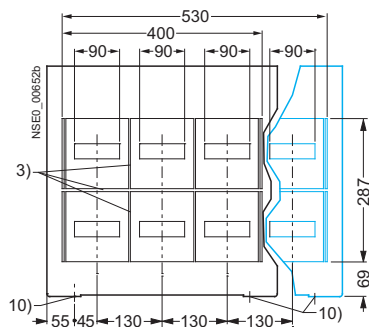
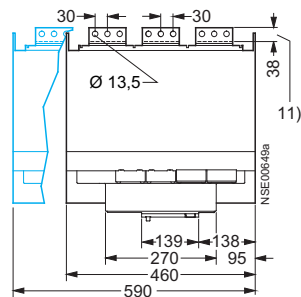
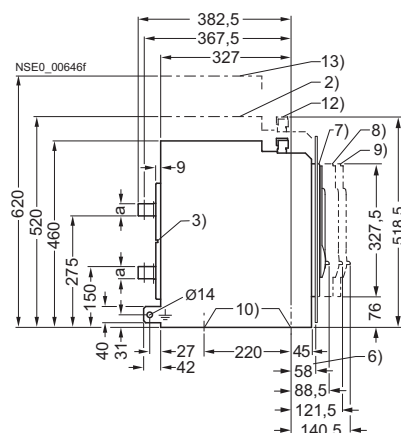
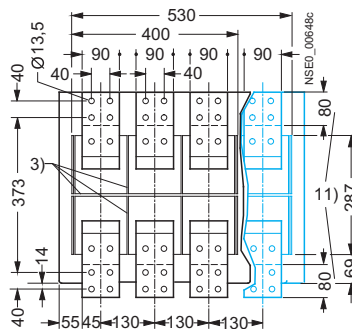
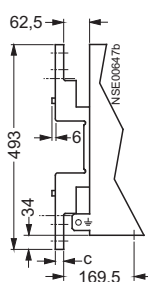

4-pole version

- 2) For guide frame ≤ 690 V, without arc chute cover, arc quenching space facing grounded or non-conductive surfaces.
- 3) Grooves (4 mm wide, 5 mm deep) for supporting phase barriers in the system.
- 4) Auxiliary connector with SIGUT screw terminals.
- 5) Auxiliary connector with spring-loaded connection.
- 6) Dimension to inside surface of the closed cabinet door.
- 7) SENTRON 3WL in connected position.
- 8) SENTRON 3WL in test position.
- 9) SENTRON 3WL in disconnected position.
- 10) Fixing holes, diameter 10 mm.
- 11) Terminal face.
- 12) Guide frame upper edge – only 1000 V AC version.
- 13) Arc quenching space, 1000 V circuit breaker facing grounded or non-conductive surfaces.

Rated circuit breaker current	a	b	c
A			
Up to 2000	10	10	10
2500	15	15	20
3200/4000	30	30	20

For safety clearances to grounded parts and to live parts see page 15/36.

For vertical connection and flange connection see following page.

15

3WL Air Circuit Breakers

3WL Air Circuit Breakers/Non-Automatic Air Circuit Breakers up to 6300 A (AC)

Project planning aids

Size II, up to 4000 A, withdrawable version, 3- and 4-pole

Vertical connection,
up to 3200 A

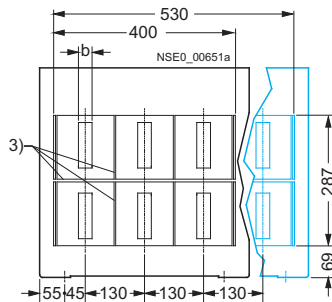
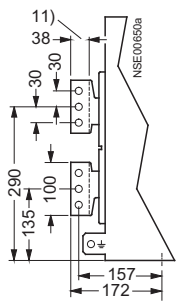

Vertical connection 4000 A

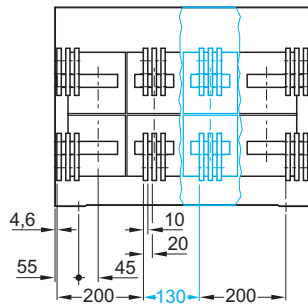
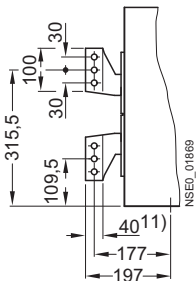

Flange connection

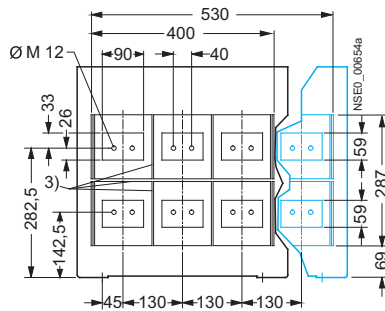
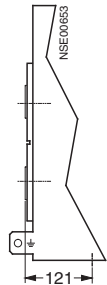

— 4-pole version

3) Grooves (4 mm wide, 5 mm deep) for supporting phase barriers in the system.

11) Terminal face.

For safety clearances to grounded parts and to live parts see page 15/36.

For more connection options see previous page.

3WL Air Circuit Breakers

3WL Air Circuit Breakers/Non-Automatic Air Circuit Breakers up to 6300 A (AC)

Project planning aids

Size III, up to 6300 A, fixed-mounted version, 3- and 4-pole

Standard version Horizontal connection

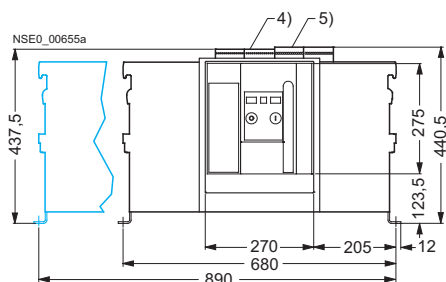

Optional connection variants Front connection (single)

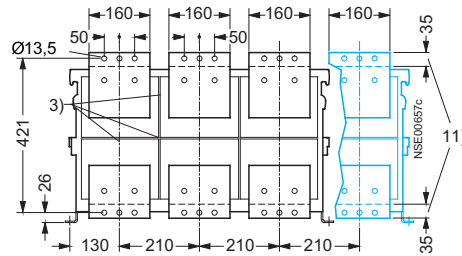
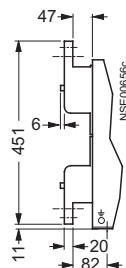

Front connection (double hole) according to DIN 43673

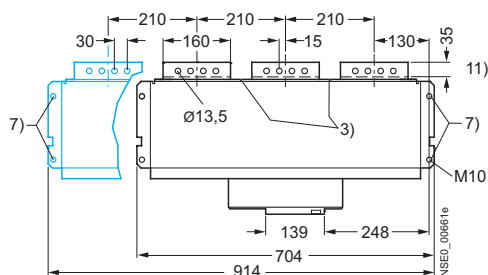
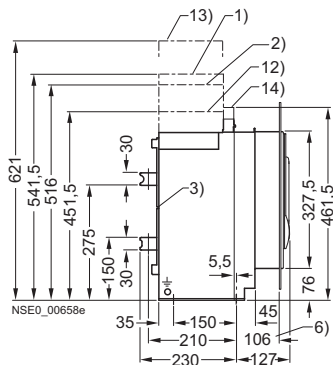
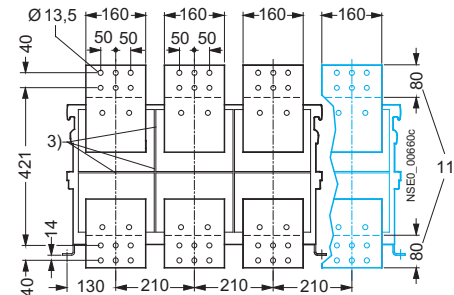
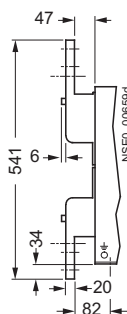

Vertical connection

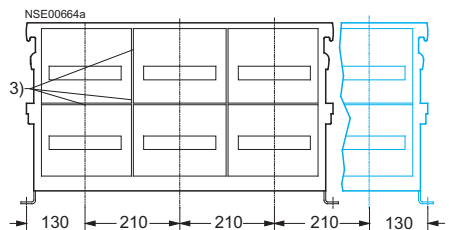
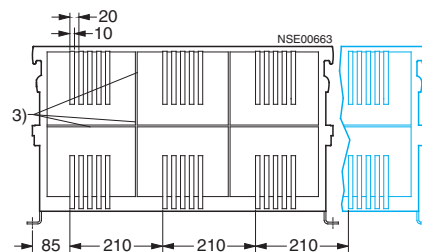
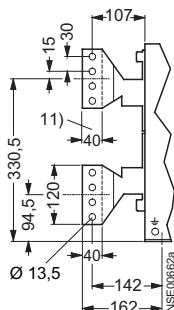

4-pole version

- 1) Mounting space for removal of the arc chutes.
- 2) Arc quenching space, "≤ 690 V" circuit breaker facing grounded or non-conductive surfaces.
- 3) Grooves (4 mm wide, 5 mm deep) for supporting phase barriers in the system.
- 4) Auxiliary connector with SIGUT screw terminals.
- 5) Auxiliary connector with spring-loaded connection.
- 6) Dimension to inside surface of the closed cabinet door.
- 7) Fixing points for mounting the circuit breaker in the system.
- 11) Terminal face.
- 12) Circuit breaker upper edge, only 1000 V circuit breaker.

- 13) Arc quenching space, 1000 V circuit breaker facing grounded or non-conductive surfaces.
- 14) Space for electrical auxiliary circuit connections.

For safety clearances to grounded parts and to live parts see page 15/36.

3WL Air Circuit Breakers/Non-Automatic Air Circuit Breakers up to 6300 A (AC)

Project planning aids

Size III, up to 6300 A, withdrawable version, 3- and 4-pole

Standard version
Horizontal connection up to 5000 A

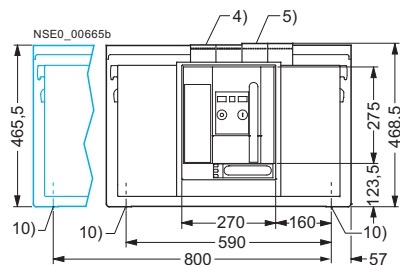

Optional connection variants
Front connection (single hole), up to 4000 A

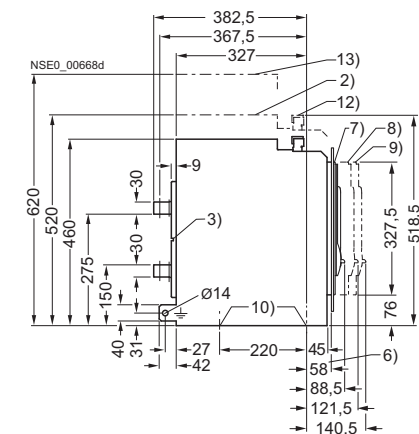
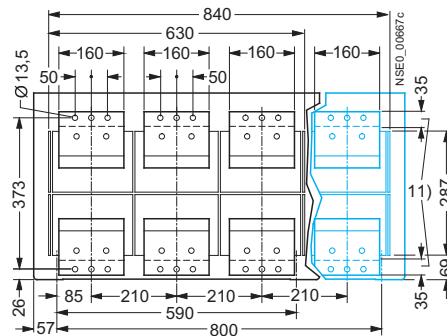
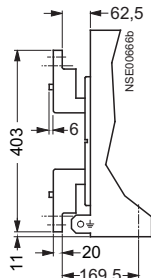

Front connection (double hole) according to DIN 43673 up to 4000 A

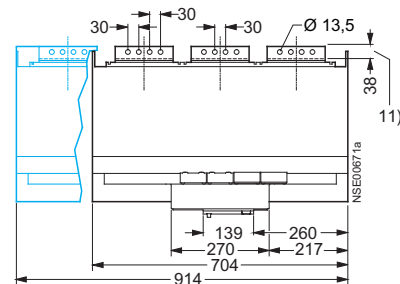
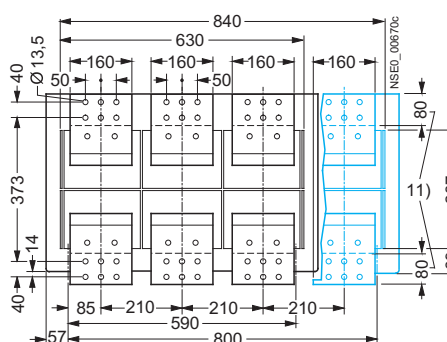
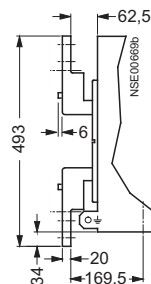

Vertical connection, up to 6300 A

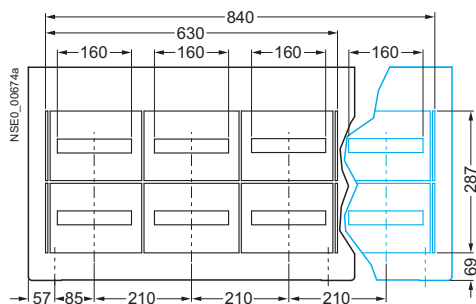
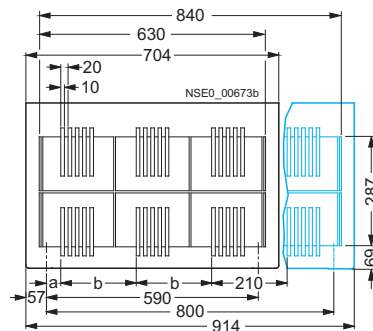
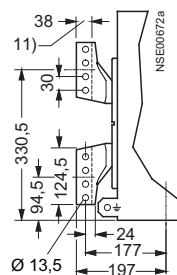

4-pole version

- 2) For guide frame ≤ 690 V, without arc chute cover, arc quenching space facing grounded or non-conductive surfaces.
- 3) Grooves (4 mm wide, 5 mm deep) for supporting phase barriers in the system.
- 4) Auxiliary connector with SIGUT screw terminals.
- 5) Auxiliary connector with spring-loaded connection.
- 6) Dimension to inside surface of the closed cabinet door.
- 7) SENTRON 3WL in connected position.
- 8) SENTRON 3WL in test position.
- 9) SENTRON 3WL in disconnected position.
- 10) Fixing holes, diameter 10 mm.
- 11) Terminal face.
- 12) Guide frame upper edge – only 1000 V guide frame.
- 13) Arc quenching space, 1000 V circuit breaker facing grounded or non-conductive surfaces.

Rated circuit breaker current A	a	b
4000	40	210
5000	40	210
6300	5	245

For safety clearances to grounded parts and to live parts see page 15/36.

For flange connections see following page.

3WL Air Circuit Breakers

3WL Air Circuit Breakers/Non-Automatic Air Circuit Breakers up to 6300 A (AC)

Project planning aids

Size III, up to 6300 A, withdrawable version, 3- and 4-pole

Flange connection, up to 4000 A

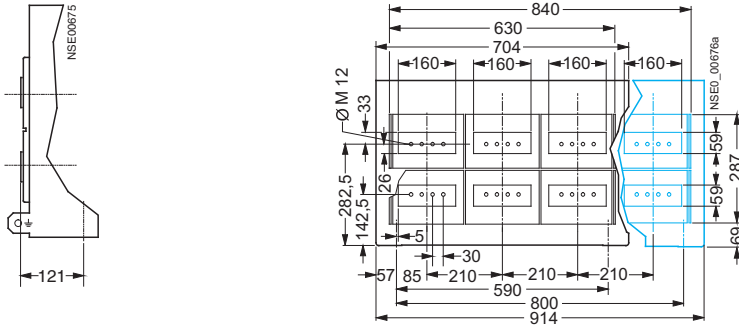

For safety clearances to grounded parts and to live parts see page 15/36.

For more connection options see previous page.

3WL Air Circuit Breakers

3WL Air Circuit Breakers/Non-Automatic Air Circuit Breakers up to 6300 A (AC)

Project planning aids

Schematics

Terminal assignment diagram

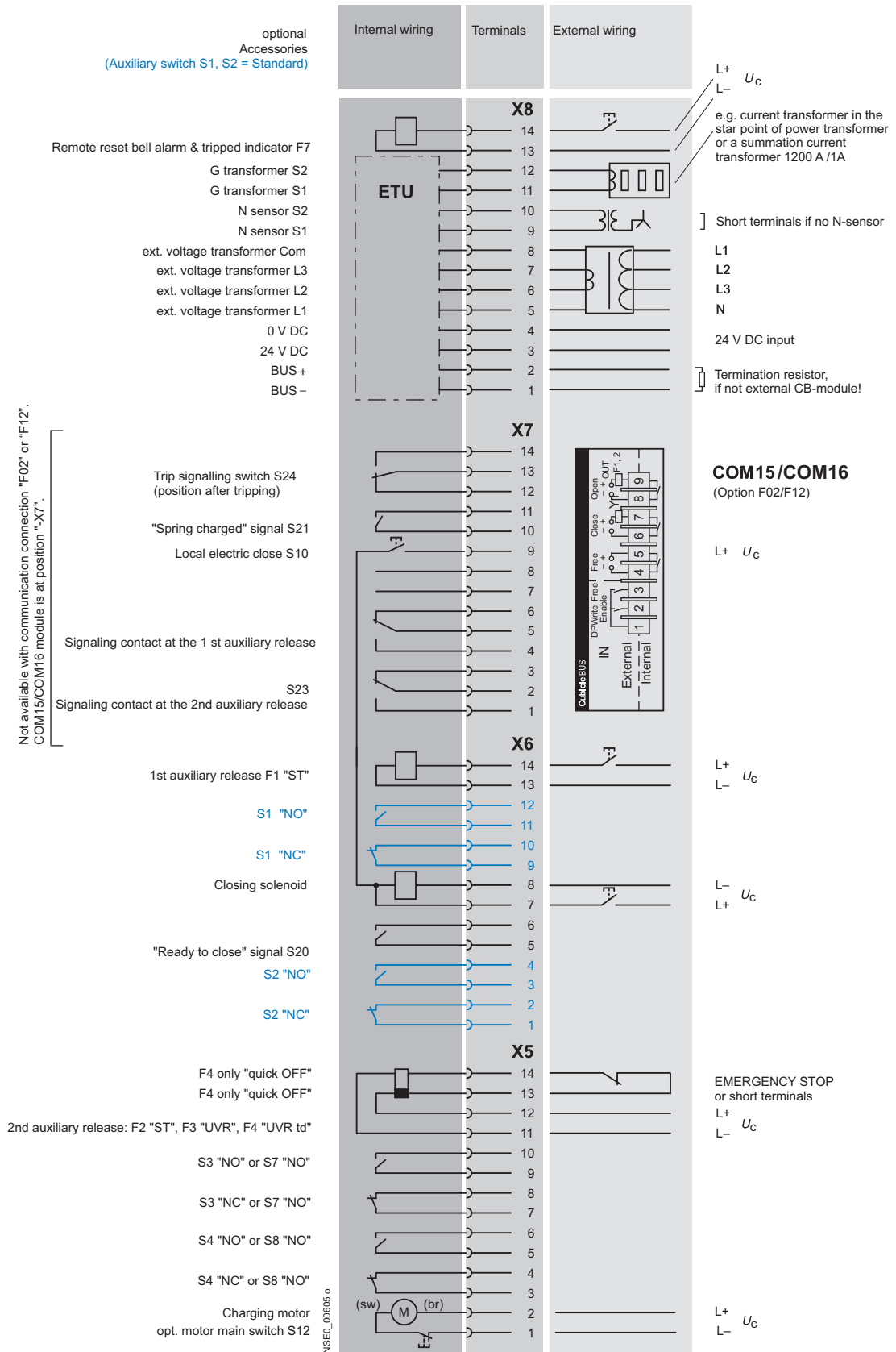

Not available with communication connection "F02" or "F12". COM15/COM16 module is at position "-X7".

NSEQ_00605 0

3WL Air Circuit Breakers

3WL Air Circuit Breakers/Non-Automatic Air Circuit Breakers up to 6300 A (AC)

Project planning aids

Example of an overall circuit diagram for SENTRON 3WL

(3WL1...-4GN4-Z C11 + C22 + K07)

Manual/motorized operating mechanism with stored-energy feature with electrical ON button (option C11), with ready-to-close signaling switch (optional C22), with LSING solid-state release,

with "UVR" undervoltage release (F3), with "ST" shunt release (F1), with tripped signal switch (option K07), with auxiliary switch 4 NO + 4 NC.

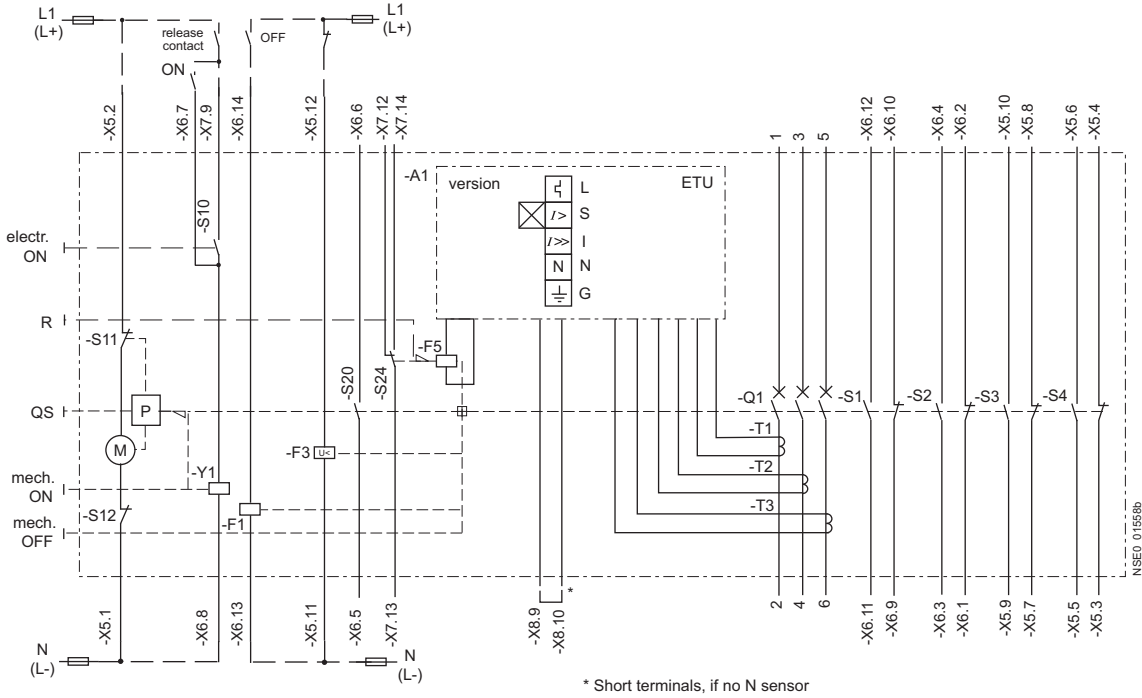

* Short terminals, if no N sensor

Function diagram of SENTRON 3WL circuit breaker

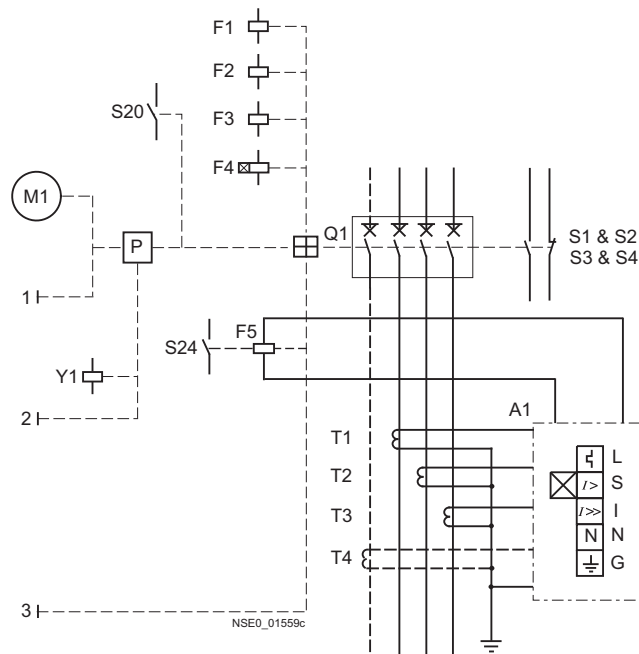

- A1 Solid-state release ETU
- S1/-S2 1st auxiliary switch block (2 NO + 2 NC)
- S3/-S4 2nd auxiliary switch block (2 NO + 2 NC)
- S7 (optional) 2nd auxiliary switch block, S7 (2 NO) can be used if there is no S3 - S3 and S7 have the same terminal assignment/mounting space
- S8 (optional) 2nd auxiliary switch block, S8 (2 NO) can be used if there is no S4 - S4 and S8 have the same terminal assignment/mounting space

- 3WL1...-...2 (2 NO + 2 NC) S1+S2
- 3WL1...-...4 (4 NO + 4 NC) S1+S2+S3+S4
- 3WL1...-...7 (6 NO + 2 NC) S1+S2+S7+S8
- 3WL1...-...8 (5 NO + 3 NC) S1+S2+S3+S8

- S10 Electrical ON button
- S11 Internal motor shutdown switch (if spring is tensioned)
- S12 Motor shutdown switch (no automatic tensioning of spring)
- S20 Ready-to-close signaling switch
- S24 Tripped signal switch
- F1 1st auxiliary release, shunt release
- F3 2nd auxiliary release, undervoltage release
- F5 Tripping solenoid
- M Motor for "charging energy store"
- P Stored-energy mechanism
- QS Actuator lever for "stored-energy mechanism"
- Q1 Main contacts
- T1/-T2/-T3 Current transformers
- X5/-X6/-X7/-X8 Terminals
- Y1 Closing solenoid
- R Indicator and reset button for solid-state release
- X8.9/-X8.10 Connection option: external neutral conductor transformer

15

3WL Air Circuit Breakers

3WL Air Circuit Breakers/Non-Automatic Air Circuit Breakers up to 6300 A (AC)

Project planning aids

Example of the mode of operation of Zone Selective Interlocking functionality in power distribution

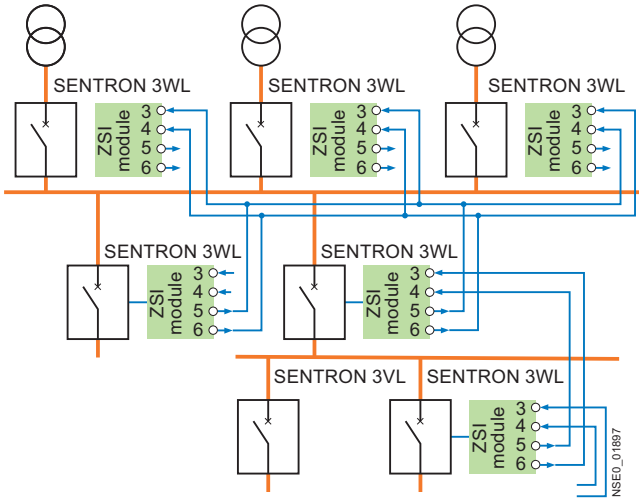

SENTRON 3VL and SENTRON 3WL circuit breakers used in various staggered levels

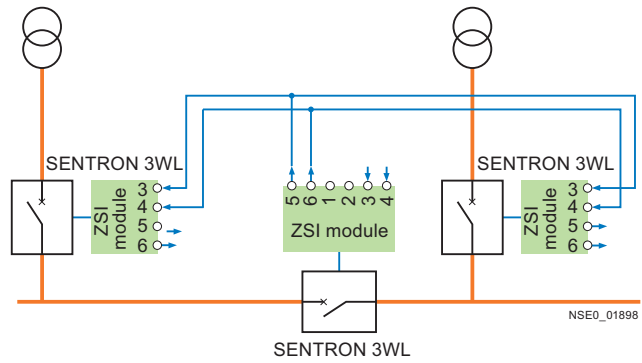

Connection diagram for a Zone Selective Interlocking functionality with multiple infeed and several outgoing units with SENTRON 3WL circuit breakers

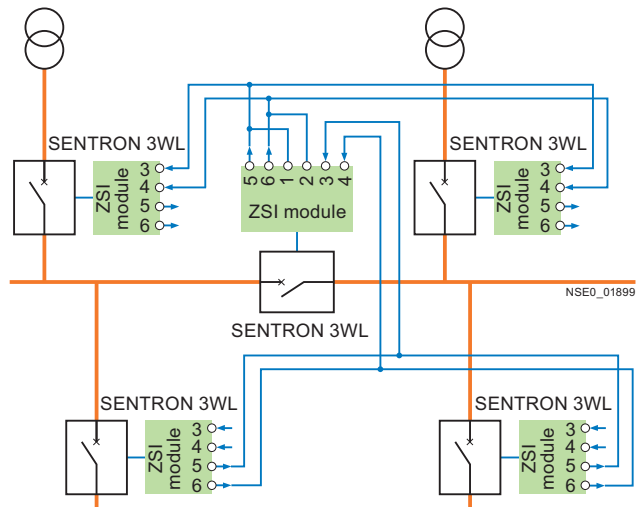

Zone Selective Interlocking functionality: Connection using a coupling switch, use of SENTRON 3WL circuit breakers

More information

Up-to-date information on the Internet at:
<http://www.siemens.com/sentron>

3WL Air Circuit Breakers

3WL Non-Automatic Air Circuit Breakers up to 4000 A (DC)

General data

Technical specifications

Size	II		
Type	3WL12 10	3WL12 20	3WL12 40
Rated current I_n at 40 °C Main conductor	A ... 1000	2000	4000
Rated operational voltage U_e (1000 V version, see Catalog LV 1, order code *A05*)	V DC ... 600/1000	... 600/1000	... 600/1000
Rated insulation voltage U_i	V DC 1000	1000	1000
Rated impulse withstand voltage U_{imp}			
• Main current paths	kV 12	12	12
• Auxiliary circuits	kV 4	4	4
• Control circuits	kV 2.5	2.5	2.5
Isolating function acc. to EN 60947-2	Yes	Yes	Yes
Permissible ambient temperature			
• Operation	°C -25/+75	-25/+75	-25/+75
• Storage	°C -40/+70	-40/+70	-40/+70
Permissible load			
Up to 40 °C	A 1000	2000	4000
At rear horizontal main circuit connections	A 1000	2000	3640
Up to 60 °C	A 1000	2000	3500
(Cu painted black) Up to 70 °C	A 1000	1950	3250
Power loss at I_n for symmetrical loads Withdrawable circuit breakers	W 280	770	1640
Operating times			
• Make-time	ms 35	35	35
• Opening time	ms 34	34	34
• Electrical make-time (through activation solenoid) ¹⁾	ms 100	100	100
• Electrical opening time (through shunt release)	ms 73	73	73
• Electrical opening time (instantaneous undervoltage release)	ms 73	73	73
Endurance³⁾			
• Mechanical (without maintenance)	Oper. cycles 10 000	10 000	10 000
• Mechanical (with maintenance) ²⁾	Oper. cycles 15 000	15 000	15 000
• Electrical (without maintenance)	Oper. cycles 6000	6000	4000
• 1000 V version	Oper. cycles 1000	1000	1000
• Electrical (with maintenance) ²⁾	Oper. cycles 15 000	15 000	15 000
Switching frequency			
• 600 V version	1/h 60	60	60
• 1000 V version	1/h 20	20	20
Mounting position			
Degree of protection	IP20 without cabinet door, IP41 with door sealing frame, IP55 with cover		
Auxiliary conductors (Cu) Standard connection = strain-relief clamp Max. number of auxiliary conductors × cross-section (solid/stranded)	<ul style="list-style-type: none"> Without end sleeve With end sleeve acc. to DIN 46228 Part 2 With twin end sleeve 	$2 \times 0.5 \text{ mm}^2$ (AWG 20) ... $2 \times 1.5 \text{ mm}^2$ (AWG 16); $1 \times 2.5 \text{ mm}^2$ (AWG 14) $1 \times 0.5 \text{ mm}^2$ (AWG 20) ... $1 \times 1.5 \text{ mm}^2$ (AWG 16) $2 \times 0.5 \text{ mm}^2$ (AWG 20) ... $2 \times 1.5 \text{ mm}^2$ (AWG 16)	
Optional connection = tension spring	<ul style="list-style-type: none"> Without end sleeve With end sleeve acc. to DIN 46228 Part 2 	$2 \times 0.5 \text{ mm}^2$ (AWG 20) ... $2 \times 2.5 \text{ mm}^2$ (AWG 14) $2 \times 0.5 \text{ mm}^2$ (AWG 20) ... $2 \times 1.5 \text{ mm}^2$ (AWG 16)	
Weights			
3-pole	<ul style="list-style-type: none"> Fixed-mounted circuit breakers Withdrawable circuit breakers Guide frames 	kg 56 kg 60 kg 31	56 60 31 45
4-pole	<ul style="list-style-type: none"> Fixed-mounted circuit breakers Withdrawable circuit breakers Guide frames 	kg 67 kg 72 kg 37	67 72 37 77 82 54

¹⁾ Make-time through activation solenoid for synchronization purposes (short-time excited) 50 ms.

²⁾ Maintenance means: replace main contact elements and arc chutes (see Operating Manual).

³⁾ Further technical specifications on request.

Size	II	
Type	3WL12	
Switching capacity class	DC	
Short-circuit breaking capacity		
Up to 220 V DC	I_{cc}	kA 35
Up to 300 V DC	I_{cc}	kA 30
Up to 600 V DC	I_{cc}	kA 25
Up to 1000 V DC	I_{cc}	kA 20
Rated short-time withstand current I_{cw}		
0.5 s		kA --
1 s		kA $35^{1)}/30^{2)}/25^{3)}/20^{4)}$
2 s		kA --
3 s		kA --

¹⁾ At $U_e = 220$ V DC.

²⁾ At $U_e = 300$ V DC.

³⁾ At $U_e = 600$ V DC.

⁴⁾ At $U_e = 1000$ V DC.

3WL Air Circuit Breakers

3WL Non-Automatic Air Circuit Breakers up to 4000 A (DC)

Project planning aids

Characteristic curves

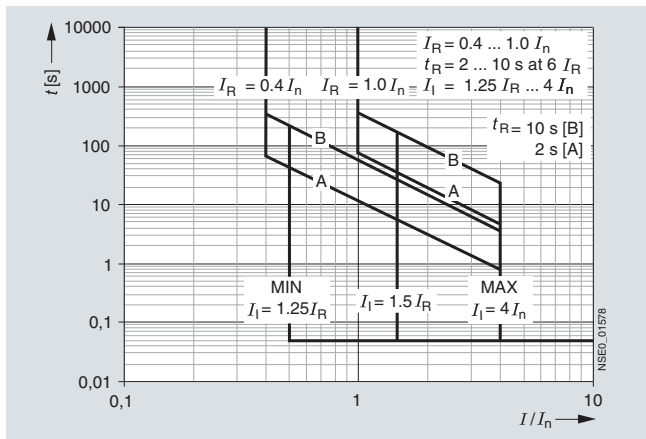

DIGmat S100 characteristic curve

Dimensional drawings

DIGmat S100

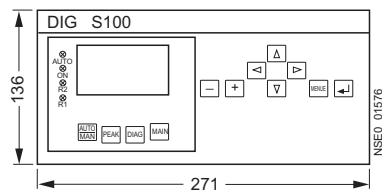

DIGmat S100

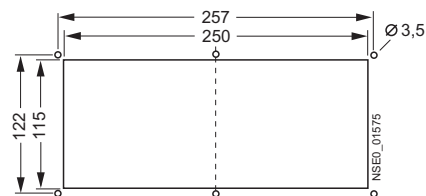

DIGmat S100 drilling pattern

3WL Air Circuit Breakers

3WL Non-Automatic Air Circuit Breakers up to 4000 A (DC)

Project planning aids

Size II, up to 4000 A, fixed-mounted version, 3- and 4-pole

Standard version
Horizontal connection

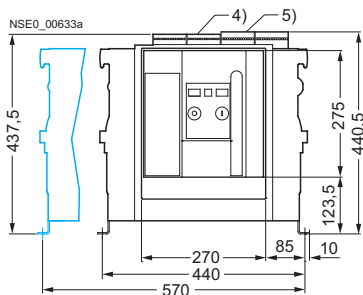

Optional connection variants
Front connection (single)

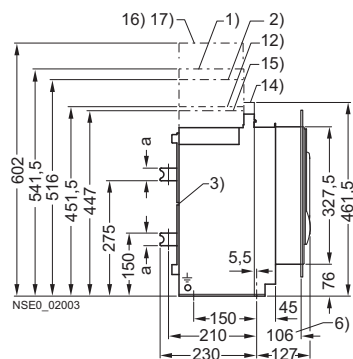
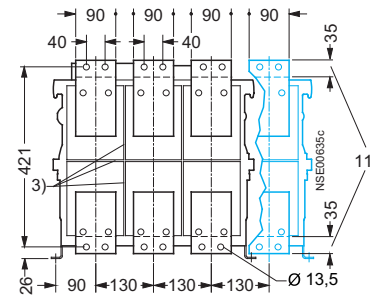
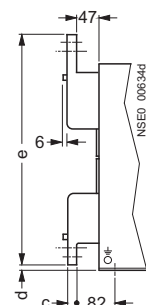

Front connection (double hole)
according to DIN 43673

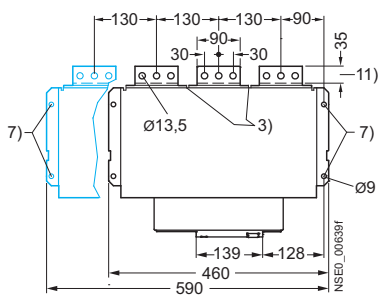
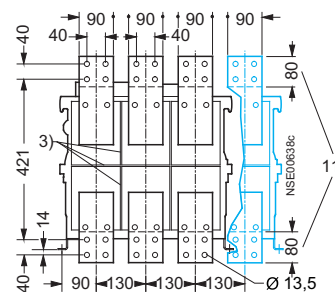
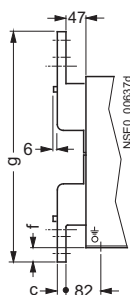

Vertical connection

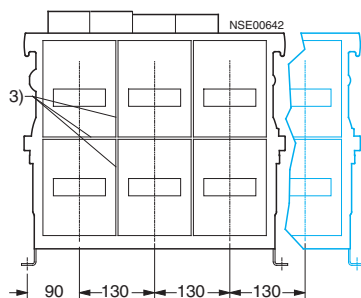
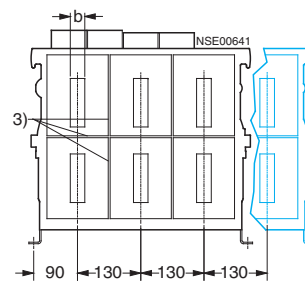
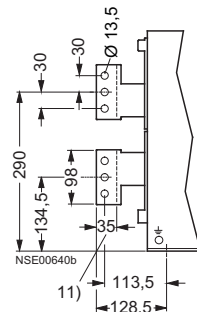

— 4-pole version

- 1) Mounting space for removal of the arc chutes.
- 2) Arc quenching space, "≤ 690 V" circuit breaker facing grounded or non-conductive surfaces.
- 3) Grooves (4 mm wide, 5 mm deep) for supporting phase barriers in the system.
- 4) Auxiliary connector with SIGUT screw terminals.
- 5) Auxiliary connector with spring-loaded connection.
- 6) Dimension to inside surface of the closed cabinet door.
- 7) Fixing points for mounting the circuit breaker in the system.
- 11) Terminal face.
- 12) Circuit breaker upper edge, only 1000 V circuit breaker.
- 14) Space for electrical auxiliary circuit connections.
- 15) Arc quenching space, 300 V circuit breaker facing grounded or non-conductive surfaces.
- 16) Arc quenching space, 600 V circuit breaker facing grounded or non-conductive surfaces.
- 17) Arc quenching space, 1000 V circuit breaker (with high arc chute) facing grounded or non-conductive surfaces.

For safety clearances to grounded parts and to live parts see page 15/36.

Rated circuit breaker current	a	b	c	d	e	f	g
A							
Up to 2000	10	10	10	11	451	34	541
4000	30	30	20	6	461	39	551

3WL Air Circuit Breakers

3WL Non-Automatic Air Circuit Breakers up to 4000 A (DC)

Project planning aids

Size II, up to 4000 A, withdrawable version, 3- and 4-pole

Standard version
Horizontal connection

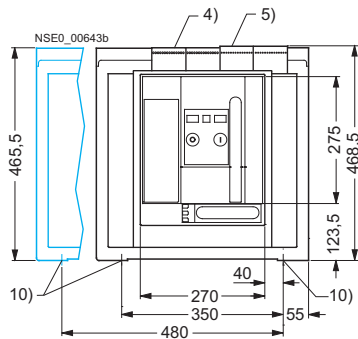

Optional connection variants
Front connection (single)

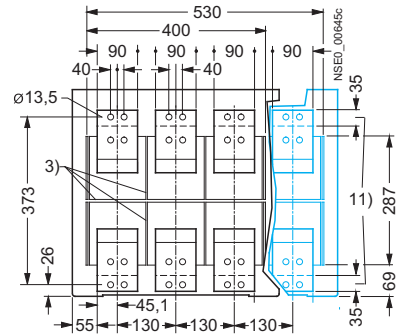
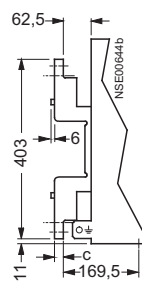

Front connection (double hole)
according to DIN 43673

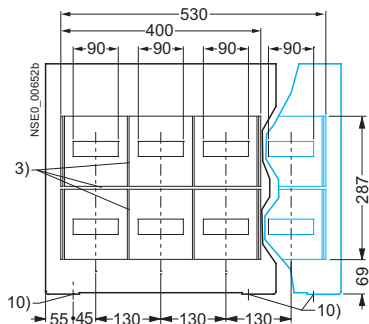
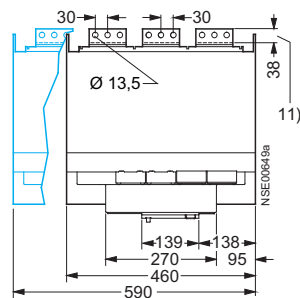
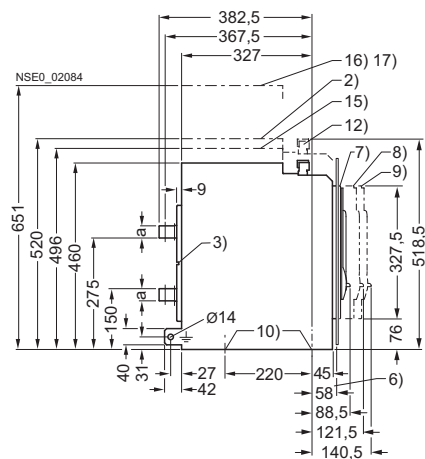
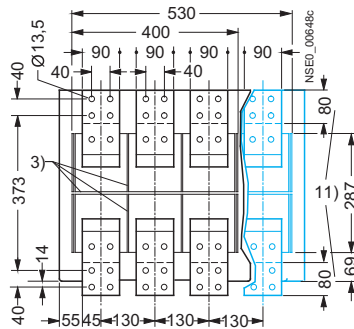
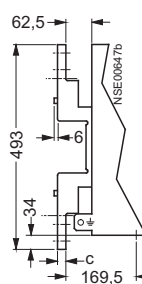

4-pole version

- 2) For guide frame ≤ 690 V, without arc chute cover, arc quenching space facing grounded or non-conductive surfaces.
- 3) Grooves (4 mm wide, 5 mm deep) for supporting phase barriers in the system.
- 4) Auxiliary connector with SIGUT screw terminals.
- 5) Auxiliary connector with spring-loaded connection.
- 6) Dimension to inside surface of the closed cabinet door.
- 7) SENTRON 3WL in connected position.
- 8) SENTRON 3WL in test position
- 9) SENTRON 3WL in disconnected position.
- 10) Fixing holes, diameter 10 mm.
- 11) Terminal face.
- 12) Guide frame upper edge – only 1000 V AC version.
- 15) Arc quenching space, 300 V circuit breaker facing grounded or non-conductive surfaces.
- 16) Arc quenching space, 600 V circuit breaker facing grounded or non-conductive surfaces.
- 17) Arc quenching space, 1000 V circuit breaker (with high arc chute) facing grounded or non-conductive surfaces.

Rated circuit breaker current	a	b	c
A			
Up to 2000	10	10	10
4000	30	30	20

For safety clearances to grounded parts and to live parts see page 15/36.

For vertical connection and flange connection see following page.

3WL Air Circuit Breakers

3WL Non-Automatic Air Circuit Breakers up to 4000 A (DC)

Project planning aids

Size II, up to 4000 A, withdrawable version, 3- and 4-pole

Vertical connection

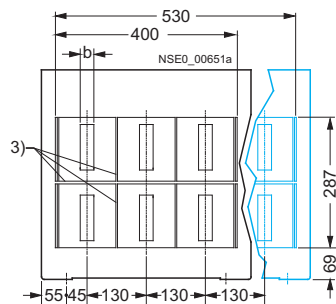
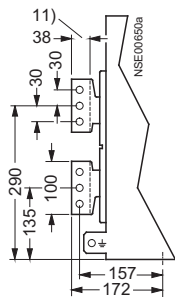

Flange connection

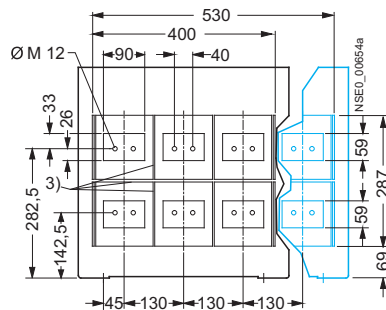
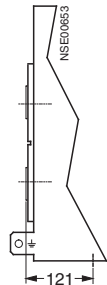

4-pole version

3) Grooves (4 mm wide, 5 mm deep) for supporting phase barriers in the system.

11) Terminal face.

For safety clearances to grounded parts and to live parts see page 15/36.

For more connection options see previous page.

3WL Air Circuit Breakers

3WL Non-Automatic Air Circuit Breakers up to 4000 A (DC)

Project planning aids

Schematics

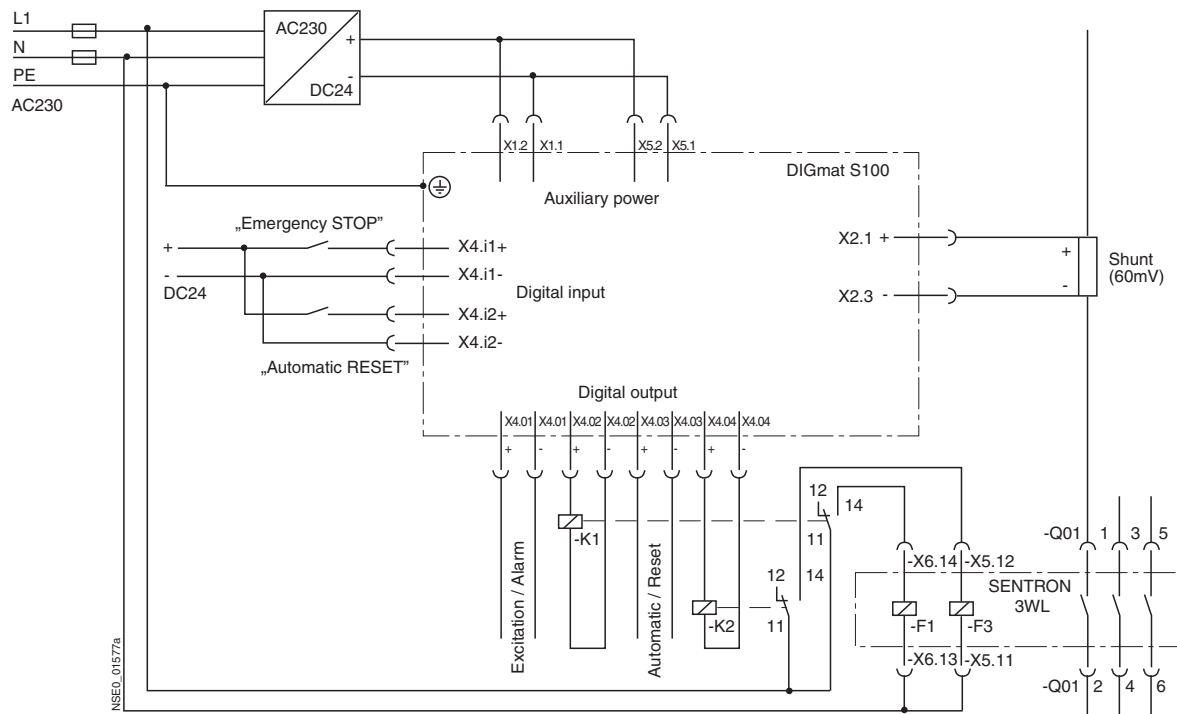

Schematics of the DIGmat S100 and the SENTRON 3WL non-automatic air circuit breaker

Application examples

Rated operational voltage	Required series breaks at rated voltage	For 3-pole non-automatic air circuit breakers (operational currents up to 4000 A/ conducting path)		For 4-pole non-automatic air circuit breakers (operational currents up to 4000 A/ conducting path)	
Up to 300 V + 10 %					
Over 300 V + 10 % Up to 600 V + 10 %					
Over 600 V + 10 % Up to 1000 V + 10 % (version for 1000 V required, order with "-Z" and order code A05)					

The connection to the circuit breakers is not dependent on direction and polarity; the circuit diagrams can be adapted accordingly.

If the parallel or series connections are made directly to the connecting bars, for thermal reasons the continuous load on the circuit breakers must only be 80 % of the permissible operational

current. If the parallel or series connection is made at a distance of 1 m from the connecting bars, the circuit breaker can be used at full operational current load.

Grounded-neutral system

Load

3WL Air Circuit Breakers

3WL Non-Automatic Air Circuit Breakers up to 4000 A (DC)

Project planning aids

More information

Up-to-date information on the Internet at:

<http://www.siemens.com/sentron>

SENTRON Switching and Protection Devices – Molded Case Circuit Breakers

16



16/2

Introduction

3VL Molded Case Circuit Breakers

3VL Molded Case Circuit Breakers
up to 1600 A

General data

- 16/6 - Design
- 16/13 - Function
- 16/16 - Integration
- 16/17 - Configuration
- 16/19 - Technical specifications

Project planning aids

- 16/26 - Characteristic curves
- 16/27 - Dimensional drawings
- 16/94 - Schematics
- 16/98 - More information

3VF2 Molded Case Circuit Breakers

3VF2 Molded Case Circuit Breakers
up to 100 A

General data

- 16/99 - Technical specifications
- Project planning aids
- 16/100 - Dimensional drawings

Introduction

Overview



Type VL160X/3VL1 VL160/3VL2 VL250/3VL3 VL400/3VL4

Molded case circuit breakers

3VL molded case circuit breakers up to 1600 A

Rated current I_n at 50 °C ambient temperature ¹⁾	A	16 ... 160	50 ... 160	200 ... 250	200 ... 400			
Number of poles		3	4	3	4			
Rated operational voltage U_e								
AC 50/60 Hz	V	690	690	690	690			
DC ²⁾	V	500	500	600	600			
Solid-state releases								
Thermal-magnetic		✓	✓	✓	✓			
Solid-state LCD ETU/ETU		--	--	✓	✓			
Replaceable		--	--	✓	✓			
PROFIBUS module COM10/COM20		--	--	✓	✓			
Dimensions								
	A	mm	105	139	105	139	139	183
	B	mm	157	157	175	175	175	279
	C	mm	81	81	81	81	81	102
	D	mm	107	107	107	107	107	138

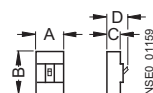
**Switching capacity I_{cu}/I_{cs}
RMS value acc. to IEC 60947-2**

Standard switching capacity N ³⁾	(N)				
Up to 240 V AC	kA	65/65	65/65	65/65	65/65
Up to 415 V AC	kA	55/55	55/55	55/55	55/55
Up to 440 V AC	kA	25/20	25/20	25/20	35/26
Up to 500/525 V AC	kA	18/14	25/20	25/20	25/20
Up to 690 V AC	kA	8/4 ⁴⁾	12/6	12/6	15/8
Up to 250 V DC ⁵⁾	kA	30/30	32/32	32/32	32/32
Up to 500 V DC ⁵⁾	kA	--	--	--	--
Up to 600 V DC ⁵⁾	kA	--	--	--	--
NEMA breaking capacity ⁶⁾					
Up to 480 V AC	kA	25	25	25	35
Up to 600 V AC	kA	8 ⁴⁾	12	12	20
High switching capacity H ³⁾	(H)				
Up to 240 V AC	kA	100/75	100/75	100/75	100/75
Up to 415 V AC	kA	70/70	70/70	70/70	70/70
Up to 440 V AC	kA	42/32	50/38	50/38	50/38
Up to 500/525 V AC	kA	30/23	40/30	40/30	40/30
Up to 690 V AC	kA	12/6 ⁴⁾	12/6	12/6	15/8
Up to 250 V DC ⁵⁾	kA	30/30	32/32	32/32	32/32
Up to 500 V DC ⁵⁾	kA	30/30	32/32	32/32	32/32
Up to 600 V DC ⁵⁾	kA	--	--	--	--
NEMA breaking capacity ⁶⁾					
Up to 480 V AC	kA	42	50	50	50
Up to 600 V AC	kA	12 ⁴⁾	12	12	20
Very high switching capacity L ³⁾	(L)				
Up to 240 V AC	kA	--	200/150	200/150	200/150
Up to 415 V AC	kA	--	100/75	100/75	100/75
Up to 440 V AC	kA	--	75/50	75/50	75/50
Up to 500/525 V AC	kA	--	50/38	50/38	50/38
Up to 690 V AC	kA	--	12/6	12/6	15/8
Up to 250 V DC ⁵⁾	kA	--	32/32	32/32	32/32
Up to 500 V DC ⁵⁾	kA	--	32/32	32/32	32/32
Up to 600 V DC ⁵⁾	kA	--	32/32	32/32	32/32
NEMA breaking capacity ⁶⁾					
Up to 480 V AC	kA	--	75	75	75
Up to 600 V AC	kA	--	12	12	20

- ✓ Available
-- Not available

¹⁾ 3VF2 at 40 °C ambient temperature.

²⁾ Rated DC voltage applies only for circuit breakers with thermal-magnetic overcurrent release.

For 3VL molded case circuit breakers according to UL 489 see Catalog LV 16.

SENTRON Switching and Protection Devices – Molded Case Circuit Breakers

Introduction



VL630/3VL5



VL800/3VL6



VL1250/3VL7



VL1600/3VL8



3VF2

3VL molded case circuit breakers up to 1600 A

3VF2 molded case circuit breakers up to 100 A

315 ... 630

800

1000 ... 1250

1600

16 ... 100

3

4

3

4

3

4

3

4

3 and 4

690
600

690
600

690
--

690
--

690
--

690
--

690
--

690
--

Up to 415
--

✓
✓
✓
✓

✓
✓
✓
✓

--
✓
✓
✓

--
✓
✓
✓

--
✓
✓
✓

--
✓
✓
✓

--
✓
✓
✓

--
✓
✓
✓

✓
--
--
--

190
279
102
138

253
279
102
138

190
406
114
151

253
406
114
151

229
406
152
207

305
406
152
207

229
406
152
207

305
406
152
207

76/102
124
68
73

65/65
45/45
35/26
25/20
20/10
32/32
--
--

65/65
50/50
35/26
25/20
20/10

65/35
50/25
35/26
25/20
20/10

65/35
50/25
35/26
25/20
20/10

65/33
18/9
--
--
--

25
20

25
20

25
20

25
20

--
--

100/75
70/70
50/38
40/30
30/15
32/32
32/32
--

100/75
70/70
50/38
40/30
30/15

100/50
70/35
50/38
40/30
30/15

100/50
70/35
50/38
40/30
30/15

--
--
--
--
--
--
--
--

50
30

50
30

50
30

50
30

--
--

200/150
100/75
75/50
50/38
20/10
32/32
32/32
32/32

200/150
100/75
75/50
50/38
20/10

200/100
100/50
75/50
50/38
35/17

200/100
100/50
75/50
50/38
35/17

--
--
--
--
--
--
--
--

65
35

65
35

65
35

65
35

--
--

3) At 240 V AC, 415 V AC and 525 V AC max. 5 % overvoltage, at 440 V AC, 500 V AC and 690 V AC max. 10 % overvoltage, at 250/500/600 V DC max. 5 % overvoltage.

4) Rated current $I_n \geq 25$ A.

5) The maximum permitted DC voltage for each conducting path needs to be taken into account for DC switching applications, see the topic "Configuring", "Switching of DC Currents"; time constant $t = 15$ ms.

6) The NEMA breaking capacity can be found on the rating plate of each IEC circuit breaker.

Introduction

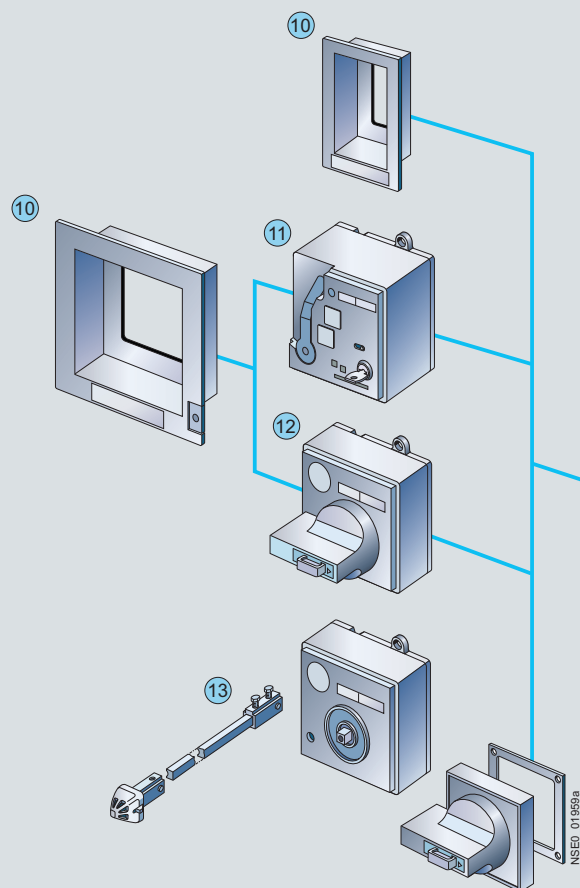

- ① Withdrawable/plug-in bases
- ② Side walls for withdrawable version
- ③ Phase barriers
- ④ Flared front busbar connecting bars
- ⑤ Straight connecting bars
- ⑥ Multiple feed-in terminals for Al/Cu
- ⑦ Box terminals for Cu
- ⑧ Extended terminal covers
- ⑨ Standard terminal covers
- ⑩ Masking frames/cover frames for door cut-out
- ⑪ Motorized operating mechanisms with spring energy store
- ⑫ Front-operated rotary operating mechanisms
- ⑬ Door-coupling rotary operating mechanisms
- ⑭ SENTRON 3VL circuit breakers
- ⑮ Internal accessories
- ⑯ Solid-state releases (LCD ETU)
- ⑰ Solid-state releases with communication function
- ⑱ Thermal-magnetic overcurrent releases
- ⑲ RCD modules
- ⑳ Rear terminals – flat and round
- ㉑ COM10 communication modules to the PROFIBUS DP
- ㉒ COM20 communication modules to the PROFIBUS DP
- ㉓ Battery power supplies with test function for solid-state releases

For additional information see [Catalog LV 1](#).

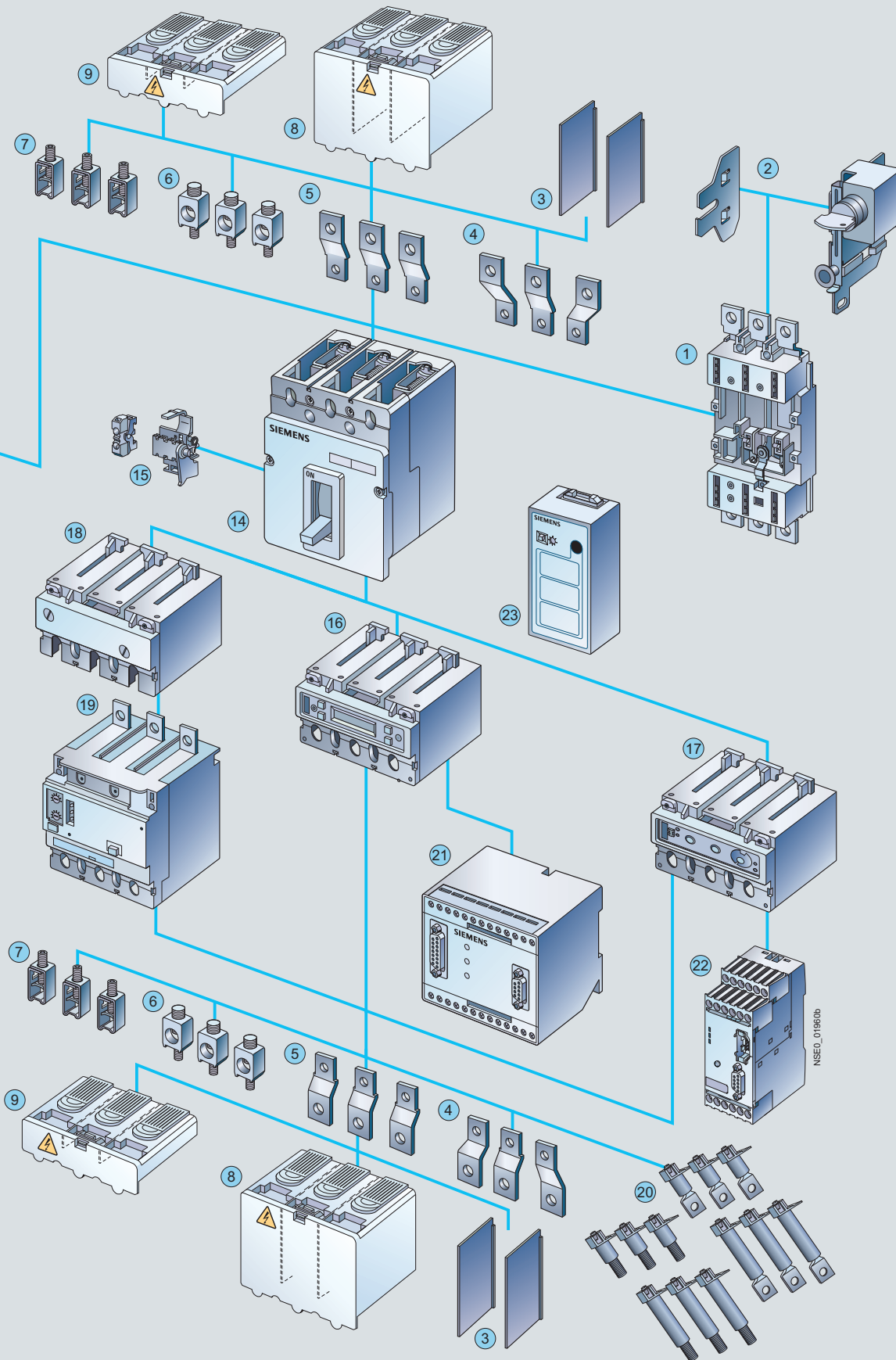

3VL Molded Case Circuit Breakers

3VL Molded Case Circuit Breakers up to 1600 A

General data

Design

- Rated current range from 16 A to 1600 A
- Different switching capacity for each size

N	Standard (45 to 55 kA)
H	High (70 kA)
L	Very high (100 kA)

- No derating or loss of performance up to 50 °C
- Solid-state releases from size 160 A (VL160), particularly for time-based discrimination and ground-fault protection
- 2 families of internal accessories
- Full range of external accessories e. g. terminals for aluminum cable.

All circuit breakers are supplied with integrated solid-state releases. The SENTRON VL160X to VL1600 circuit breakers are available with busbar connection pieces or box terminals (up to 400 A; see "Main Connections, Basic Equipment and Options", page 16/12). Auxiliary switches/alarm switches or auxiliary releases can be easily adapted by the customer, or they are also available ready installed if required.

The breaking capacity is shown on the front of every circuit breaker.

- Standard switching capacity:
 $I_{Cu} = 45$ to 55 kA at AC 50/60 Hz 380/415 V
- High switching capacity:
 $I_{Cu} = 70$ kA at AC 50/60 Hz 380/415 V
- Very high switching capacity:
 $I_{Cu} = 100$ kA at AC 50/60 Hz 380/415 V

Standards and specifications

SENTRON 3VL circuit breakers comply with:

IEC 60947-1, EN 60947-1,
IEC 60947-2, EN 60947-2,

Isolating features according to IEC 60947-2, EN 60947-2

Disconnecting features (main control switches) according to EN 60204-1.

The SENTRON 3VL circuit breakers comply in addition with requirements for "disconnecter units with features for stopping and switching off in an emergency" (EMERGENCY-STOP switches) in conjunction with lockable rotary operating mechanisms (red-yellow) and terminal covers.

Please contact Siemens for details of other standards.

The solid-state releases of the circuit breakers for motor protection also comply with IEC 60947-4-1, EN 60947-4-1.

VL160X to VL400 circuit breakers can be equipped with a SENTRON 3VL RCD module. They then comply with IEC 60947-2 Appendix B.

The SENTRON 3VL RCD module complies with IEC 61000-4-2 to IEC 61000-4-6, IEC 61000-4-11 and EN 55011, Class B (equivalent to CISPR 11) with regard to electromagnetic compatibility.

Degree of protection

Circuit breaker	IP20
Masking frame	IP40
Terminal cover	IP30
With front-operated rotary operating mechanism	IP40
With door-coupling rotary operating mechanism	IP65
With motorized operating mechanism	IP30
With motorized operating mechanism and masking frame for the door cut-out	IP40
Plug-in base/withdrawable version	IP20

Connection

The SENTRON VL160X to VL160 circuit breakers can be factory-fitted with incoming and outgoing box terminals which are suitable for stranded conductors, flexible copper bars and finely stranded conductors with end sleeves, as well as with screw terminals for flat connectors. Different feeder terminals are available for VL630 to VL1600 (sizes 630 A to 1600 A).



Appropriate accessories for screw terminal to fixed and flexible copper bars or cables are available for SENTRON VL160X to VL1600 circuit breakers.

SENTRON VL160X to VL1600 circuit breakers can be equipped with connecting bars. These are intended for connection of standard busbars and can be used for front or rear connection. The SENTRON VL1600 circuit breaker is supplied with front connecting bars.

The incoming and outgoing terminals for the circuit breaker can be freely selected. The electrical specifications remain the same.

The infeed for circuit breakers with RCD modules can be connected above or below.

For 4-pole circuit breakers, the fourth pole (N pole) of the main current path is 100 % loadable with the rated current.

Bare conductors at the top connections must be insulated in the arc quenching space that is necessary above the arc chutes. Phase barriers or terminal covers can be used for this purpose.

For the SENTRON VL160X to VL1600 circuit breakers, the connections for the internal accessories (auxiliary releases, auxiliary switches and alarm switches) are supplied with terminal screws.

The auxiliary releases (shunt releases and undervoltage releases), auxiliary switches and alarm switches for all SENTRON 3VL circuit breakers can be connected easily and directly.

The motorized operating mechanisms with spring energy stores are always equipped with terminals. The leading auxiliary switches for the rotary operating mechanisms are always supplied with connecting cables.

3VL Molded Case Circuit Breakers

3VL Molded Case Circuit Breakers up to 1600 A

General data

SENTRON VL160X circuit breakers

The main components of the SENTRON VL160X circuit breakers are the three conducting paths with the incoming and outgoing terminals. The fixed and moving contacts are designed in such a way that the contacts are magnetically repelled if there is a short-circuit. In conjunction with the arcing chambers, a dynamic impedance is created that causes current limiting due to a reduction in the damaging effects of I^2t and I_p energy that arises during short-circuits.

The release is preassembled and equipped with fixed or adjustable overload releases as well as with fixed short-circuit releases for each pole.

The circuit breaker is trip-free.

To the right and left of the operating mechanism, the double-insulated accessory compartments are situated for the auxiliary releases and auxiliary switches.

SENTRON VL160 to VL630 circuit breakers

The arrangement of the conducting path, main contact and switching mechanism corresponds to that of the SENTRON VL160X circuit breakers.

The releases for the SENTRON VL160 to VL630 have the following features:

- The releases are available in thermal-magnetic and solid-state versions.
- The thermal-magnetic releases have adjustable overload and short-circuit releases.

SENTRON VL800 to VL1600 circuit breakers

The arrangement of the conducting paths and switching mechanisms corresponds with those of the SENTRON VL160X to VL630 circuit breakers.

The SENTRON VL800 to VL1600 circuit breakers are only available with solid-state releases.

As is the case for all versions of the SENTRON 3VL circuit breakers with solid-state releases, the current transformers are in the same enclosure as the releases. They send a signal which is proportional to the load current to the solid-state overcurrent release.

All SENTRON 3VL circuit breakers with solid-state releases measure the actual r.m.s. current. This type of measurement is the most accurate method. Currents in today's electrical distribution systems with many harmonics are evaluated reliably.

Overcurrent release systems

The overcurrent release systems can be replaced by the customer using a special tool.

When the solid-state release has been installed in the circuit breaker, it is recommended that it is tested with the battery power supply using the 3VL9 000-8AP00 test function.

1. Solid-state release system of the SENTRON VL160X to VL630 circuit breakers - thermal-magnetic

The overcurrent and short-circuit releases function with bimetallic and magnetic releases. They are available in fixed set or adjustable versions.

The 4-pole circuit breakers for system protection can be equipped with solid-state releases for all four poles or without a solid-state release for the fourth pole (N). Depending on the size, circuit breakers are available with a release in the fourth pole (N) with 60 % or 100 % of the current of the 3 main current paths.

The circuit breakers for starter combination applications are usually combined with a motor contactor and a suitable overload relay.

The non-automatic air circuit breakers have an integrated short-circuit self-protection system eliminating the need for back-up fuses. Non-automatic air circuit breakers have no overload protection. 4-pole non-automatic air circuit breakers do not have a short-circuit release for the fourth pole (N).

2. Solid-state release system for SENTRON VL160 to VL1600 circuit breakers, solid-state, ETU

The solid-state overcurrent release system consists of:

- 3 current transformers
- Evaluation electronics with microprocessor
- Internal power supply, no external auxiliary voltage necessary
- Tripping solenoid

The 4-pole circuit breakers for system protection can be equipped with solid-state releases for all four poles or without a solid-state release for the fourth pole (N).

On ETU releases the neutral conductor protection is adjustable to 50 % or 100 %. On LCD ETU releases the neutral conductor protection is adjustable from 50 to 100 % or can be switched off.

For the LCD ETU on the SENTRON VL160 and VL250, the tripping solenoid is installed in the left accessory compartment.

The protection functions of the solid-state releases are maintained without additional auxiliary voltage. The solid-state releases are supplied with energy through circuit breaker-internal current transformers.

The solid-state release has to be activated for parameterizing. This requires a load current of at least 20 % of the respective rated current I_n of the circuit breaker. If this load current is not available, the necessary auxiliary power can be fed in through a 3VL9 000-8AP00 battery power supply. For communication-capable circuit breakers the release is supplied with energy through the communication module.

At the output of the solid-state overcurrent release module there is a tripping solenoid which trips in the case of overload or short-circuit.

- N** Circuit breakers with standard switching capacity N (I_{cu} up to 55 kA at 415 V)
- H** Circuit breakers with high switching capacity H (I_{cu} up to 70 kA at 415 V)
- L** Circuit breakers with very high switching capacity L (I_{cu} up to 100 kA at 415 V)

These circuit breakers are indicated in the Technical specifications by orange backgrounds.

3VL Molded Case Circuit Breakers

3VL Molded Case Circuit Breakers up to 1600 A

General data

RCD modules

- Easy mounting
- Assembly kit for lateral mounting according to EN 60715 for SENTRON VL160X circuit breakers under Order No. 3VL9 112-5GB30/3VL9 112-5GB40
- A tripping button enables the function of the integrated RCD module to be tested.
- Protruding reset/tripping button (prevents the circuit breaker from being reclosed before the reset/tripping button has been reset)
- Circuit for remote-controlled tripping of the circuit breaker does not require an additional external voltage supply (for SENTRON VL160 to VL400 circuit breakers)
- LED displays which enable visual monitoring of the RCD module:
 - Green
 $\leq 25\% I_{\Delta n}$ of $I_{\Delta n}$
 - Green + Yellow
 $25\% < I_{\Delta n} = 50\%$ of the set $I_{\Delta n}$
 - Green + Yellow + Red
 $I_{\Delta n} \geq 50\%$ of the set $I_{\Delta n}$

- RCD alarm switch (changeover contact) for VL160 to VL400 to indicate a tripping operation by the RCD module
- 690 V AC application
- "Power disconnect" enables electrical testing without disconnecting the cables
- The functional properties of the circuit breaker are not adversely affected by the addition of the RCD module
- Internal power supply, no external voltage

(For diagrams see Catalog LV1 "Accessories".)

Abbreviations (functions)

L	= Long Time Delay	= Overload protection
S	= Short Time Delay	= Short-circuit protection (short-time delayed)
I	= Instantaneous	= Short-circuit protection (instantaneous)
N	= Neutral Protection	= Neutral conductor protection
G	= Ground Fault	= Ground-fault protection

L, S, I, N, G designations according to IEC 60947-2, Appendix K

3VL Molded Case Circuit Breakers

3VL Molded Case Circuit Breakers up to 1600 A

General data

VL160 to VL1600 solid-state releases – Overview of functions

Order No. supplement	Releases	System protection	Motor protection	Starter protection	Generator protection	Function	Setting options					
							L	S ¹⁾		I ¹⁾	G	
							Overload protection $I_r = \times I_n$	Short-circuit protection (short-time delayed) $I_{sd} = \times I_r$ t_{sd} [s]		Short-circuit protection (instantaneous) $I_i = \times I_n$	Ground-fault protection $I_g = \times I_n$ t_g [s]	
DK	M	--	--	✓	--	I	--	--	--	7 ... 15	--	--
DC	TM ²⁾	✓	--	--	--	LI	0.8 ... 1	--	--	5 ... 10	--	--
EJ	TM ²⁾	✓	--	--	--	LI	0.8 ... 1	--	--	5 ... 10	--	--
EC	TM ²⁾	✓	--	--	--	LIN	0.8 ... 1	--	--	5 ... 10	--	--
EM	TM ²⁾	✓	--	--	--	LIN	0.8 ... 1	--	--	5 ... 10	--	--
SP	ETU10M ³⁾	--	✓	--	✓	LI	0.4 ... 1	--	--	1.25 ... 11	--	--
MP	ETU10M ³⁾	--	✓	--	✓	LI	0.4 ... 1	--	--	1.25 ... 11	--	--
SB	ETU10	✓	--	--	--	LI	0.4 ... 1	--	--	1.25 ... 11	--	--
MB	ETU10	✓	--	--	--	LI	0.4 ... 1	--	--	1.25 ... 11	--	--
TA	ETU10	✓	--	--	--	LIN	0.4 ... 1	--	--	1.25 ... 11	--	--
NA	ETU10	✓	--	--	--	LIN	0.4 ... 1	--	--	1.25 ... 11	--	--
TB	ETU10	✓	--	--	--	LI	0.4 ... 1	--	--	1.25 ... 11	--	--
NB	ETU10	✓	--	--	--	LI	0.4 ... 1	--	--	1.25 ... 11	--	--
SL	ETU12	✓	--	--	--	LIG	0.4 ... 1	--	--	1.25 ... 11	0.6 ... 1, OFF	0.1 ... 0.3
ML	ETU12	✓	--	--	--	LIG	0.4 ... 1	--	--	1.25 ... 11	0.6 ... 1, OFF	0.1 ... 0.3
SF	ETU12	✓	--	--	--	LING	0.4 ... 1	--	--	1.25 ... 11	0.6 ... 1, OFF	0.1 ... 0.3
MF	ETU12	✓	--	--	--	LING	0.4 ... 1	--	--	1.25 ... 11	0.6 ... 1, OFF	0.1 ... 0.3
TN	ETU12	✓	--	--	--	LING	0.4 ... 1	--	--	1.25 ... 11	0.6 ... 1, OFF	0.1 ... 0.3
NN	ETU12	✓	--	--	--	LING	0.4 ... 1	--	--	1.25 ... 11	0.6 ... 1, OFF	0.1 ... 0.3
SE	ETU20	✓	--	--	✓	LSI	0.4 ... 1	1.5 ... 10	0 ... 0.5	11	--	--
ME	ETU20	✓	--	--	✓	LSI	0.4 ... 1	1.5 ... 10	0 ... 0.5	11	--	--
TE	ETU20	✓	--	--	✓	LSI	0.4 ... 1	1.5 ... 10	0 ... 0.5	11	--	--
NE	ETU20	✓	--	--	✓	LSI	0.4 ... 1	1.5 ... 10	0 ... 0.5	11	--	--
TF	ETU20	✓	--	--	✓	LSIN	0.4 ... 1	1.5 ... 10	0 ... 0.5	11	--	--
NF	ETU20	✓	--	--	✓	LSIN	0.4 ... 1	1.5 ... 10	0 ... 0.5	11	--	--
SG	ETU22	✓	--	--	✓	LSIG	0.4 ... 1	1.5 ... 10	0 ... 0.5	11	0.6 ... 1, OFF	0.1 ... 0.3
MG	ETU22	✓	--	--	✓	LSIG	0.4 ... 1	1.5 ... 10	0 ... 0.5	11	0.6 ... 1, OFF	0.1 ... 0.3
SH	ETU22	✓	--	--	✓	LSING	0.4 ... 1	1.5 ... 10	0 ... 0.5	11	0.6 ... 1, OFF	0.1 ... 0.3
MH	ETU22	✓	--	--	✓	LSING	0.4 ... 1	1.5 ... 10	0 ... 0.5	11	0.6 ... 1, OFF	0.1 ... 0.3
TH	ETU22	✓	--	--	✓	LSING	0.4 ... 1	1.5 ... 10	0 ... 0.5	11	0.6 ... 1, OFF	0.1 ... 0.3
NH	ETU22	✓	--	--	✓	LSING	0.4 ... 1	1.5 ... 10	0 ... 0.5	11	0.6 ... 1, OFF	0.1 ... 0.3
SS	ETU30M ³⁾	--	✓	--	✓	LI	0.4 ... 1	--	--	6/8/11	--	--
MS	ETU30M ³⁾	--	✓	--	✓	LI	0.4 ... 1	--	--	6/8/11	--	--
CP	LCD ETU40M ³⁾	--	✓	--	✓	LI	0.4 ... 1	--	--	1.25 ... 11	--	--
CH	LCD ETU40	✓	--	--	--	LI, LSI	0.4 ... 1	1.5 ... 10	0 ... 0.5	1.25 ... 11	--	--
CJ	LCD ETU40	✓	--	--	--	LI, LSIN	0.4 ... 1	1.5 ... 10	0 ... 0.5	1.25 ... 11	--	--
CL	LCD ETU42	✓	--	--	--	LSIG	0.4 ... 1	1.5 ... 10	0 ... 0.5	1.25 ... 11	0.4 ... 1	0.1 ... 0.5
CM	LCD ETU42	✓	--	--	--	LSIG	0.4 ... 1	1.5 ... 10	0 ... 0.5	1.25 ... 11	0.4 ... 1	0.1 ... 0.5
CN	LCD ETU42	✓	--	--	--	LSIG, LSING	0.4 ... 1	1.5 ... 10	0 ... 0.5	1.25 ... 11	0.4 ... 1	0.1 ... 0.5

1) Size-dependent.

2) TM up to $I_n = 630$ A.3) Motor protection up to $I_n = 500$ A.

3VL Molded Case Circuit Breakers

3VL Molded Case Circuit Breakers up to 1600 A

General data

Order No. supplement	Releases	Thermal image	Phase failure	Communication-capable	Ground-fault protection	Number of poles	N pole protected ¹⁾	I^2t (ON/OFF)	Trip class (t_c)	Time-lag class (t_R)	Thermo-magnetic release	Magnetic release	Solid-state release	LCD display
DK	M	--	--	--	--	3	--	--	--	--	--	✓	--	--
DC	TM ²⁾	✓	--	--	--	3	--	--	--	--	✓	--	--	--
EJ	TM ²⁾	✓	--	--	--	4	--	--	--	--	✓	--	--	--
EC	TM ²⁾	✓	--	--	--	4	60 %	--	--	--	✓	--	--	--
EM	TM ²⁾	✓	--	--	--	4	100 %	--	--	--	✓	--	--	--
SP	ETU10M ³⁾	✓	40 % I_R	--	--	3	--	--	10	--	--	--	✓	--
MP	ETU10M ³⁾	✓	40 % I_R	✓ ⁴⁾	--	3	--	--	10	--	--	--	✓	--
SB	ETU10	✓	--	--	--	3	--	--	--	2.5 ... 30	--	--	✓	--
MB	ETU10	✓	--	✓ ⁴⁾	--	3	--	--	--	2.5 ... 30	--	--	✓	--
TA	ETU10	✓	--	--	--	4	50/100 %	--	--	2.5 ... 30	--	--	✓	--
NA	ETU10	✓	--	✓ ⁴⁾	--	4	50/100 %	--	--	2.5 ... 30	--	--	✓	--
TB	ETU10	✓	--	--	--	4	--	--	--	2.5 ... 30	--	--	✓	--
NB	ETU10	✓	--	✓ ⁴⁾	--	4	--	--	--	2.5 ... 30	--	--	✓	--
SL	ETU12	✓	--	--	①	3	--	✓	--	2.5 ... 30	--	--	✓	--
ML	ETU12	✓	--	✓ ⁴⁾	①	3	--	✓	--	2.5 ... 30	--	--	✓	--
SF	ETU12	✓	--	--	②	3	50/100 %	✓	--	2.5 ... 30	--	--	✓	--
MF	ETU12	✓	--	✓ ⁴⁾	②	3	50/100 %	✓	--	2.5 ... 30	--	--	✓	--
TN	ETU12	✓	--	--	②	4	50/100 %	✓	--	2.5 ... 30	--	--	✓	--
NN	ETU12	✓	--	✓ ⁴⁾	②	4	50/100 %	✓	--	2.5 ... 30	--	--	✓	--
SE	ETU20	✓	--	--	--	3	--	✓	--	--	--	--	✓	--
ME	ETU20	✓	--	✓ ⁴⁾	--	3	--	✓	--	--	--	--	✓	--
TE	ETU20	✓	--	--	--	4	--	✓	--	--	--	--	✓	--
NE	ETU20	✓	--	✓ ⁴⁾	--	4	--	✓	--	--	--	--	✓	--
TF	ETU20	✓	--	--	--	4	50/100 %	✓	--	--	--	--	✓	--
NF	ETU20	✓	--	✓ ⁴⁾	--	4	50/100 %	✓	--	--	--	--	✓	--
SG	ETU22	✓	--	--	①	3	--	✓	--	--	--	--	✓	--
MG	ETU22	✓	--	✓ ⁴⁾	①	3	--	✓	--	--	--	--	✓	--
SH	ETU22	✓	--	--	②	3	50/100 %	✓	--	--	--	--	✓	--
MH	ETU22	✓	--	✓ ⁴⁾	②	3	50/100 %	✓	--	--	--	--	✓	--
TH	ETU22	✓	--	--	②	4	50/100 %	✓	--	--	--	--	✓	--
NH	ETU22	✓	--	✓ ⁴⁾	②	4	50/100 %	✓	--	--	--	--	✓	--
SS	ETU30M ³⁾	✓	40 % I_R	--	--	3	--	--	10, 20, 30	--	--	--	✓	--
MS	ETU30M ³⁾	✓	40 % I_R	✓ ⁴⁾	--	3	--	--	10, 20, 30	--	--	--	✓	--
CP	LCD ETU40M ³⁾	✓	5 ... 50 % I_R	✓ ⁵⁾	--	3	--	--	5, 10, 15, 20, 30	--	--	--	✓	✓
CH	LCD ETU40	✓	--	✓ ⁵⁾	--	3	--	✓	--	2.5 ... 30	--	--	✓	✓
CJ	LCD ETU40	✓	--	✓ ⁵⁾	--	4	50 ... 100 %, OFF	✓	--	2.5 ... 30	--	--	✓	✓
CL	LCD ETU42	✓	--	✓ ⁵⁾	①	3	--	✓	--	2.5 ... 30	--	--	✓	✓
CM	LCD ETU42	✓	--	✓ ⁵⁾	①/③	3	--	✓	--	2.5 ... 30	--	--	✓	✓
CN	LCD ETU42	✓	--	✓ ⁵⁾	②	4	50 ... 100 %, OFF	✓	--	2.5 ... 30	--	--	✓	✓

Ground-fault protection

- ① Vectorial summation current formation (3-conductor system)
 ② Vectorial summation current formation (4-conductor system)
 ③ Direct detection of ground-fault current in the neutral point of the transformer

- 1) Size-dependent.
 2) TM up to $I_n = 630$ A.
 3) Motor protection up to $I_n = 500$ A.
 4) With COM20/COM21.
 5) With COM10/COM11.

3VL Molded Case Circuit Breakers

3VL Molded Case Circuit Breakers up to 1600 A

General data

Internal accessories (auxiliary switches, undervoltage releases, shunt releases)

The SENTRON 3VL circuit breakers can be supplied with all the internal accessories (e. g. auxiliary switches, undervoltage releases or shunt releases). The available versions can be found in the tables with the Order No. supplements.

Fixed-mounted, plug-in or withdrawable version

The fixed-mounted circuit breaker is the basic version. This can be converted very easily into a plug-in or withdrawable version with the aid of the appropriate assembly kit. This kit contains blade contacts, a locking pin and terminal covers for the plug-in version. The assembly kit for the withdrawable version also contains side covers and a racking mechanism. Even with the masking frame mounted, it is still possible to move using the handle with the door closed.

Operating mechanisms

The basic versions of the SENTRON 3VL circuit breakers are equipped with a toggle lever as an operating mechanism which is also used as a switch position indicator. In addition to "ON" and "OFF", "Tripped" is also indicated.

The toggle lever assumes the "tripped" position when the internal tripping mechanism is activated by an overcurrent tripping, e. g. an overload or short-circuit. The activation of an undervoltage release or shunt release also causes the toggle lever to assume the "tripped" position. The toggle lever must be put into the "OFF/RESET" position before the circuit breakers can be reclosed. It will then be possible to reset the internal tripping mechanism and reclose the main contacts on the circuit breaker (see illustration).

A toggle handle extension is supplied with the SENTRON VL1250 and VL1600 circuit breakers. This accessory must be ordered separately for SENTRON VL400 to VL800 circuit breakers, if required.

Front-operated rotary operating mechanisms

These operating mechanisms have been designed for direct mounting to the circuit breaker and change the toggle lever movement from a linear to a rotary motion.

A leading voltage can be applied to the undervoltage release of a circuit breaker with leading auxiliary switches which makes the circuit breaker ready-to-close.

Door-coupling rotary operating mechanisms (complete operating mechanisms)

Door-coupling rotary operating mechanisms and removable covers are available for circuit breakers which are installed into control cabinets and distribution boards. These are supplied as complete assembly kits, including an articulated-shaft mechanism.

With regard to the switching status indication and the "RESET" position, the same applies to the rotary operating mechanisms as to the toggle lever. The position of the operator lever (knob) indicates the status.

All rotary operating mechanisms can be locked in the OFF position with the help of suitable padlocks. This means that all SENTRON 3VL circuit breakers which have these operating mechanisms as well as the corresponding terminal covers can be used as main control switches.

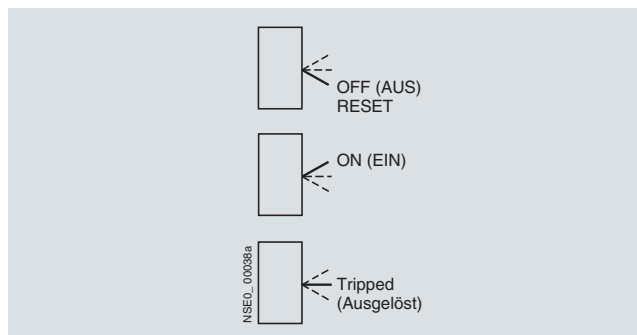

Toggle lever operating mechanism positions

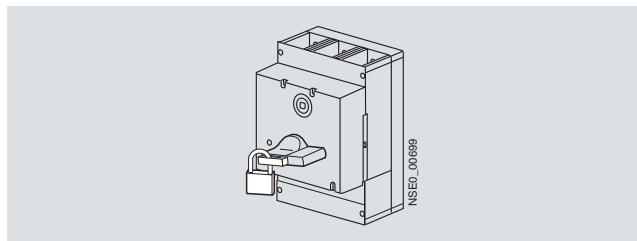

Rotary operating mechanism secured with a padlock

Motorized operating mechanisms

The SENTRON VL160X to VL1600 circuit breakers (sizes 160 to 1600 A) can be equipped with motorized operating mechanisms for remote opening and closing during operation.

These motorized operating mechanisms for SENTRON VL160X to VL800 circuit breakers have a stored-energy feature (for synchronization) with a maximum ON period of $t_E \leq 100$ ms.

For SENTRON VL160X, VL160, VL250, VL1250 and VL1600 circuit breakers there are motorized operating mechanisms without a stored-energy feature for remote-controlled ON and OFF switching.

All motorized operating mechanisms are always supplied with a locking device for padlocks. Optional safety locks are also available for motorized operating mechanisms with stored-energy feature.

These locking devices can be used to block the operating mechanism electrically and mechanically. All remote-controlled operating mechanisms are equipped with a manual operation option for maintenance purposes.

The motorized operating mechanisms with stored-energy feature for VL160X to VL800 as well as the motorized operating mechanisms for VL1250 and VL1600 are each optionally equipped inside with a signaling contact (NO) for the following functions:

- Querying the AUTO/Manual selector for VL160X to VL800 (not possible with VL1250 to VL1600)
- Actuating the mechanical OFF/0 button

3VL Molded Case Circuit Breakers

3VL Molded Case Circuit Breakers up to 1600 A

General data

Main connections, basic equipment and options

Box terminal (for copper cables or solid/flexible busbars)

Connection with screw terminal (available with direct cable lug connection on VL160X, VL160, VL250, VL400)

Connection to front busbar connecting bars (screw terminal required)

Circular conductor terminal/multiple feed-in terminal (for Al/Cu terminal)

Main circuit connections (for conductor cross-sections see "Technical Specifications", page 16/19)

Circuit breakers	Connection overview and further options				
	Box terminals	Screw terminal with metric thread for flat connectors	Circular conductor terminal/multiple feed-in terminal	Rear-mounting terminals	Front-accessible connecting bars
VL160X	□	□	x	x	x
VL160	□	□	x	x	x
VL250	□	□	x	x	x
VL400	x	○	x ²⁾³⁾	x	x
VL630	x ¹⁾	○	x ²⁾	x	x
VL800	--	○	x ²⁾	x	x
VL1250	--	○	x ²⁾	x	x
VL1600	--	x	--	x	○

- Scope of supply
- Optional scope of supply
- x Available
- Not available

- 1) Connecting terminal plate for flexible busbar; not for 690 V AC/600 V DC.
- 2) Multiple feed-in terminal.
- 3) Circular conductor terminal also available.

Auxiliary releases and auxiliary switches

Undervoltage releases, leading auxiliary switches

If there is no voltage present, closing of the circuit breaker is not possible. If voltage is not applied to the releases, operation of the circuit breaker will result in no-load switching.

Frequent re-tripping should be avoided because of its adverse effect on the endurance of the circuit breaker.

All undervoltage releases are designed and tested so that they meet all applicable requirements in accordance with IEC 60947 (drop-out voltage 0.70 to 0.35 U_e , response voltage 0.85 to 1.10 U_e).

A leading voltage can be applied to the undervoltage release of a circuit breaker with leading auxiliary switches which makes the circuit breaker ready-to-close.

For SENTRON 3VL circuit breakers, the leading auxiliary switch can be supplied with the front rotary operating mechanism or complete operating mechanism. For more detailed information please see "Selection and Ordering Data" for accessories in Catalog LV 1.

Shunt releases

The shunt release is used for remote tripping of the circuit breaker.

The coil of the shunt release is designed for short-time operation only. A coil trip is implemented internally.

These devices operate according to IEC 60947 (tripping voltage 0.70 to 1.10 U_e).

It is not permissible to apply a continuous trip command to a shunt release to prevent closing when the circuit breaker is tripped.

A central tap is provided as standard for checking the conductivity of the coil.

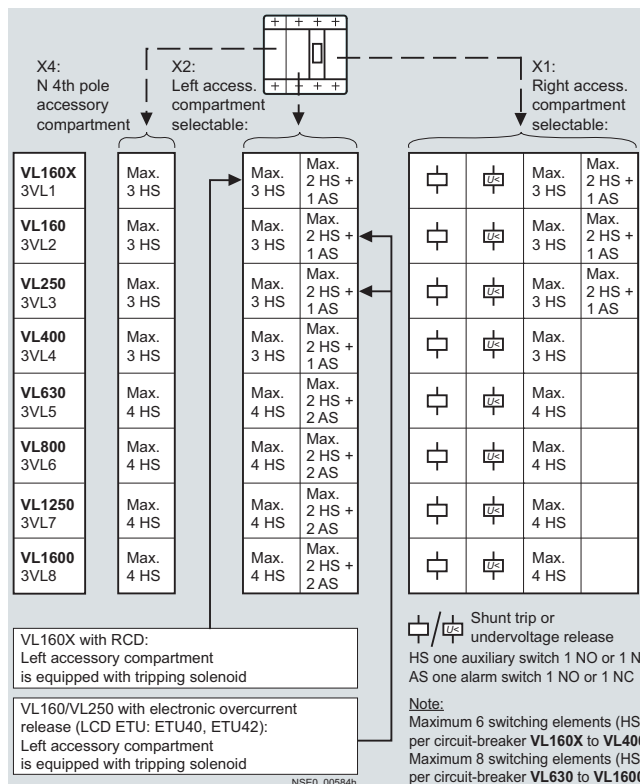

Possible complements for the insulated accessory subsections in the SENTRON 3VL circuit breakers

Before ordering, use the table above to check whether the required combination of shunt releases, undervoltage releases and auxiliary/alarm switches is feasible.

3VL Molded Case Circuit Breakers

3VL Molded Case Circuit Breakers up to 1600 A

General data

Auxiliary switches

Auxiliary switches are used for indication and control. The contacts of the auxiliary switch close and open together with the main contacts.

Alarm switch

The alarm switches (AS) are activated when the circuit breaker has been tripped due to an overcurrent e. g. overload or short-circuit. However, they are also activated if the circuit breaker has been tripped by a shunt release or undervoltage release.

Installation of internal accessories

The insulated accessory subsections for installing accessories (auxiliary releases and auxiliary switches/alarm switches) have the designations X1, X2 and X4.

The equipping of the circuit breaker with internal accessories and the configuration possibilities for circuit breakers with auxiliary releases and auxiliary/alarm switches depend on the mounting position and size of the circuit breaker (see the illustration "Possible Complements for the Insulated Accessory Subsections of the 3VL Circuit Breakers").

PLC control

The auxiliary and alarm switches can be used to send signals to programmable controllers. These switching blocks are part of the Siemens 3SB3 range.

Leading auxiliary switches

The leading auxiliary switches OFF to ON or ON to OFF are available as a retrofit set for rotary operating mechanisms.

Function

Current limiting

The SENTRON 3VL circuit breakers utilize the design principle of magnetic repulsion of the contacts. The contacts open before the anticipated peak value of the short-circuit current is achieved. The current-limiting effects of the SENTRON 3VL circuit breakers provide effective protection for system components against the thermal and dynamic effects of the short-circuit current in the event of an electrical fault.

Ground-fault protection

Ground-fault release "G" senses fault currents that flow to ground and that can cause fire in the plant. Several circuit breakers connected in series can provide graduated discrimination by means of the adjustable delay time.

The following measurement methods can be used to detect neutral conductor and ground-fault currents:

Vectorial summation current formation (measurement method 1)

Ground-fault detection in symmetrically loaded systems

The three phase currents are evaluated with the help of the vectorial summation current formation.

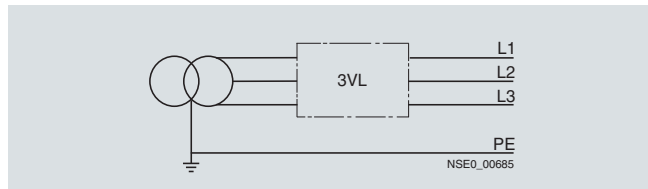

Ground-fault detection in asymmetrically loaded systems

The neutral conductor current is measured directly. For the 3-pole circuit breakers this measurement is only evaluated for ground-fault protection; for 4-pole circuit breakers it is also evaluated for neutral conductor overload protection.

The solid-state release determines the ground-fault current for the three phase currents and neutral conductor current by means of vectorial summation current formation.

For 4-pole circuit breakers, the fourth current transformer for the neutral conductor is installed internally.

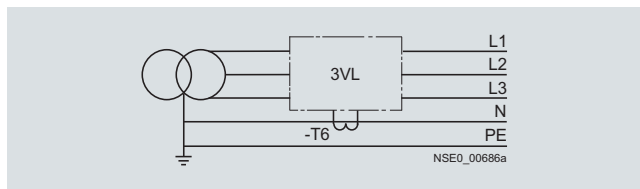

3-pole circuit breaker, current transformer in the neutral conductor

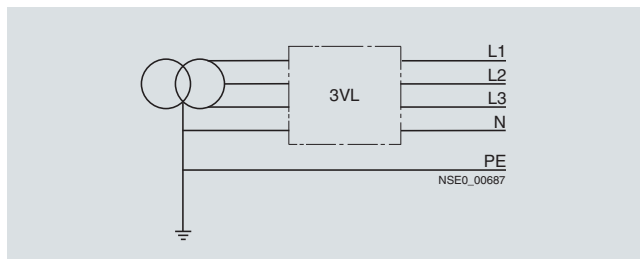

4-pole circuit breaker, current transformer installed internally

Direct detection of the ground-fault current through a current transformer in the grounded neutral point of the transformer (measurement method 2)

The current transformer is installed directly in the grounded neutral point of the transformer.

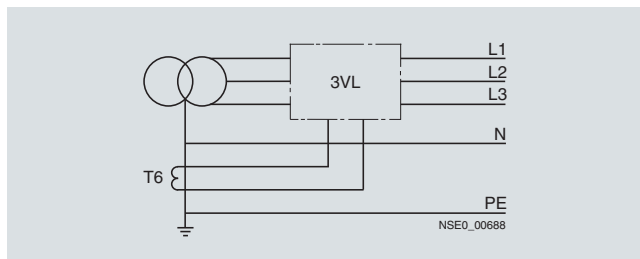

3-pole circuit breakers, current transformers in the grounded neutral point of the transformer

For RCD modules see Catalog LV 1 "Accessories".
For external current transformers see Catalog LV 1, "Accessories".

Transformer protection

The SENTRON 3VL circuit breakers protect power distribution systems against overload and short-circuit on the low-voltage side of the infeed transformer. The resulting requirements with respect to current-based and/or time-based discrimination are reliably fulfilled by the SENTRON 3VL circuit breakers for system protection (equipped with thermal-magnetic (TM) or solid-state overcurrent releases (ETU or LCD ETU)).

3VL Molded Case Circuit Breakers

3VL Molded Case Circuit Breakers up to 1600 A

General data

Thermal-magnetic overcurrent releases TM¹⁾



Application: system protection –
TM, LI/LIN function

Overload protection, fixed, short-circuit protection, fixed; see "Selection and ordering data" for VL160X, releases installed in the switch enclosure

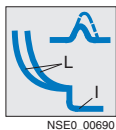

Application: system protection –
TM, LI/LIN function

Overload protection adjustable $I_R = 0.8$ to $1 \times I_n$, short-circuit protection, fixed, see "Selection and ordering data" for VL160X, releases installed in the switch enclosure



Application: system protection –
TM, LI/LIN function

Overload protection adjustable $I_R = 0.8$ to $1 \times I_n$, short-circuit protection, adjustable $I_i = 5$ to $10 \times I_n$, for VL160 to VL630



Application: starter protection –
M, I function

Short-circuit protection, adjustable $I_i = 7$ to $15 \times I_n$, for VL160 to VL630²⁾

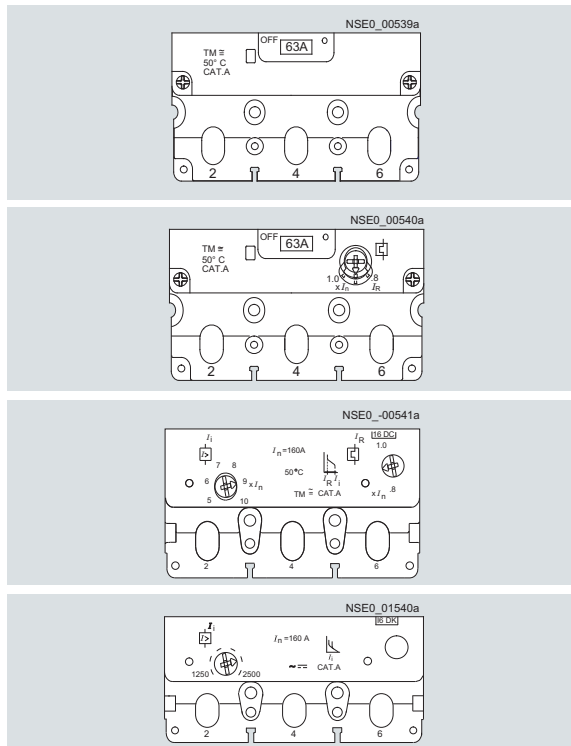

Solid-state releases ETU

For types VL160 to VL1600

General information:

- No auxiliary voltage for release required
- All ETUs have a thermal image
- Flashing green LED indicates faultless operation of microprocessor

- Overload status ($I > 1.05 \times I_n$) is indicated by continuous yellow LED (alarm)
- Integrated self-test function
- Female connector for test unit

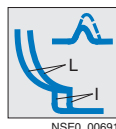

Application: system protection – ETU10,
LI/LIN function

Overload protection $I_R = 0.4$; 0.45; 0.5 to 0.95; $1 \times I_n$, time-lag class $t_R = 2.5$ to 30

Short-circuit protection (instantaneous) $I_i = 1.25$ to $11 \times I_n$ ²⁾

Neutral conductor protection $I_N = 50\%$ / $100\% \times I_R$, versions "TA" and "NA".

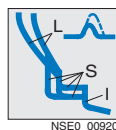
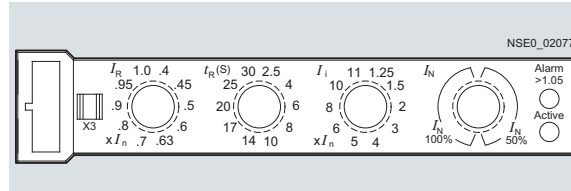

Application: system and generator protection –
ETU20, LSI/LSIN function

Overload protection $I_R = 0.4$; 0.45; 0.5 to 0.95; $1 \times I_n$,

Short-circuit protection (short-time delayed) $I_{sd} = 1.5$ to $10 \times I_R$ ²⁾, $t_{sd} = 0$ to 0.5 s,

I^2t selectable on/off

Short-circuit protection (instantaneous) $I_i = 11 \times I_n$ (fixed)²⁾

Neutral conductor protection $I_N = 50\%$ / $100\% \times I_R$, versions "TF" and "NF".

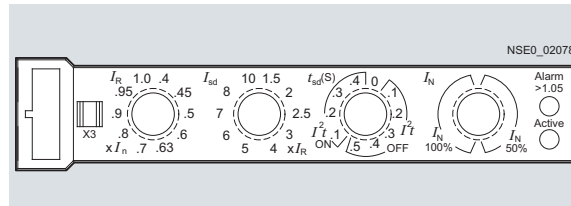

1) Operating temperature TM TU: 0°C ... 75°C.

2) Size-dependent, see Catalog LV 1, "Selection and ordering data".

3VL Molded Case Circuit Breakers

3VL Molded Case Circuit Breakers up to 1600 A

General data



Application: system protection –
ETU12, LIG/LING function

Overload protection $I_R = 0.4; 0.45; 0.5$ to $0.95; 1 \times I_n$, time-lag class $t_R = 2.5$ to 30

Short-circuit protection (instantaneous)
 $I_i = 1.25$ to $11 \times I_n$ ¹⁾

For 4-pole circuit breakers:
Neutral conductor protection $50\%/100\% \times I_R$

Ground-fault protection: measurement method 1:
 $I_g = 0.6/1.0 I_n$, $t_g = 0.1/0.3$ s,
(G_R) vectorial summation current formation for the currents of the three phases/and neutral conductor (four-conductor systems); $I_{\Delta n} = I_n$, versions "SL", "SF", "ML", "MF", "TN", "NN" (for Order No. supplements see Catalog LV 1, "Selection and ordering data").

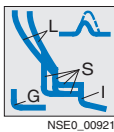
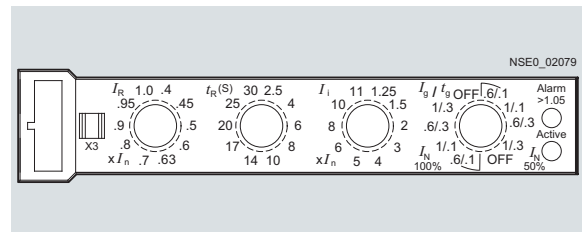

Application: system and generator protection –
ETU22, LSIG/LSING function

Overload protection $I_R = 0.4; 0.45; 0.5$ to $0.95; 1 \times I_n$,

Short-circuit protection (short-time delayed)
 $I_{sd} = 1.5$ to $10 \times I_R$, $t_{sd} = 0$ to 0.5 s,

I^2t selectable on/off

Short-circuit protection (instantaneous) $I_i = 11 \times I_n$ (fixed)¹⁾

For 4-pole circuit breakers:
Neutral conductor protection $50\%/100\% \times I_R$

Ground-fault protection: measurement method 1:
 $I_g = 0.6/1.0 I_n$, $t_g = 0.1/0.3$ s,
(G_R) vectorial summation current formation for the currents of the three phases/and neutral conductor (four-conductor systems);
 $I_{\Delta n} = I_n$, versions "SG", "SH", "MG", "MH", "TH", "NH" (for Order No. supplements see Catalog LV 1, "Selection and ordering data").

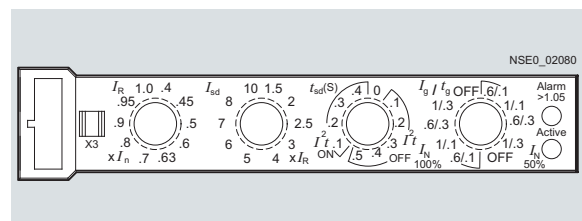

Application: motor protection – ETU10M,
LI function

Overload protection, finely adjustable $I_R = 0.41; 0.42$ to $0.98; 0.99; 1 \times I_n$,
trip class $t_c = 10$ (fixed)

Thermal image

Short-circuit protection (instantaneous)
 $I_i = 1.25$ to $11 \times I_n$ ¹⁾
with phase failure sensitivity (40 % I_R fixed).

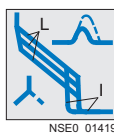
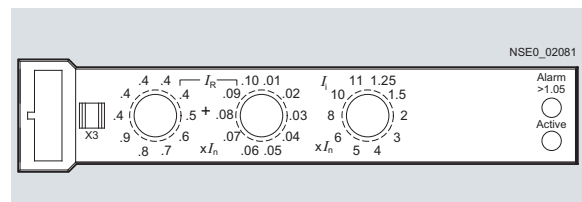

Application: motor protection – ETU30M,
LI function

Overload protection, finely adjustable $I_R = 0.41; 0.42$ to $0.98; 0.99; 1 \times I_n$,
trip class $t_c = 10, 20, 30$

Thermal image

Short-circuit protection (instantaneous)
 $I_i = 6$ to $11 \times I_n$
with phase failure sensitivity (40 % I_R fixed).

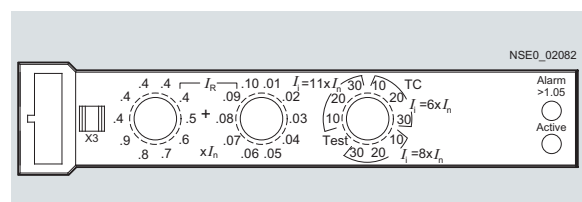

¹⁾ Size-dependent, see Catalog LV 1, "Selection and ordering data".

3VL Molded Case Circuit Breakers

3VL Molded Case Circuit Breakers up to 1600 A

General data

Solid-state releases LCD ETU

General information:

- No auxiliary voltage for release required
- Current indicator
- Illuminated LCD display indicates faultless operation of microprocessor
- The overload status ($I > 105\% I_R$) is indicated by "overload" on the LCD display

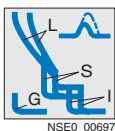
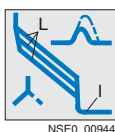
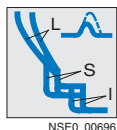

Application: system protection – ETU40, LI/LS/LSI/LIN/LSIN functions and motor protection – ETU40M, LI function

Overload protection $I_R = 0.4$ to $1 \times I_n$,
trip class $t_c = 5$ to 30 for ETU40M,
time-lag class $t_R = 2.5$ to 30 for ETU40

Thermal image memory, selectable On/Off,
with phase failure sensitivity for ETU40M
($5 \dots 50\% I_R$ adjustable)

Short-circuit protection (short-time delayed) for
ETU40

$I_{sd} = 1.5$ to $10 \times I_R$, $t_{sd} = 0$ to 0.5 s,

Application: system protection – ETU42, LSIG/LSING function

Overload protection $I_R = 0.4$ to $1 \times I_n$,
time-lag class $t_R = 2.5$ to 30

On/off selectable thermal image

Short-circuit protection (short-time delayed)
 $I_{sd} = 1.5$ to $10 \times I_R$, $t_{sd} = 0$ to 0.5 s,

I^2t selectable on/off

Short-circuit protection (instantaneous)
 $I_i = 1.25$ to $11 \times I_n$ ¹⁾

Ground-fault protection: measurement method 1:
(G_R) vectorial summation current formation for the
currents of the three phases/and neutral conductor
(four-conductor systems);
 $I_{\Delta n} = 0.4$ to $1 \times I_n$, versions "CL", "CM", "CN" (for Order
No. supplements see Catalog LV 1, "Selection and
ordering data").

¹⁾ Size-dependent, see Catalog LV 1, "Selection and ordering data".

- User-friendly, menu-driven setting of protection parameters in absolute ampere values by means of keys
- Integrated self-test function
- Female connector for test unit
- For communications integration to PROFIBUS DP see section "Communication".

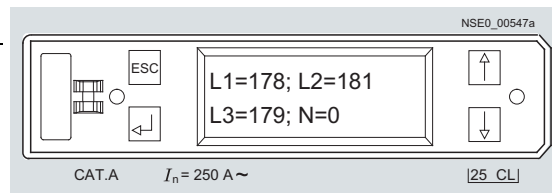

I^2t selectable on/off for ETU40

Short-circuit protection (instantaneous)
 $I_i = 1.25$ to $11 \times I_n$ ¹⁾

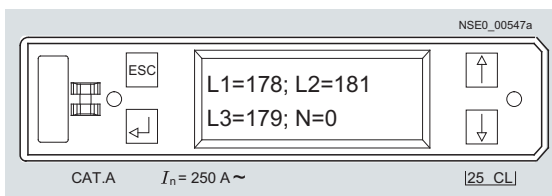

Measurement method 2:

(G_{GND}) direct detection of ground-fault current by means of current transformer, $I_g = 0.4$ to $1 \times I_n$, $t_g = 0.1$ to 0.5 s; version "CM" (for Order No. supplement see Catalog LV 1, "Selection and ordering data").

For 4-pole circuit breakers:

Neutral conductor protection N: 50 to $100\% I_R$ adjustable or can be switched off.

Integration

Mounting

The SENTRON 3VL circuit breakers are suitable for use in open and enclosed switchboards and distribution systems. The recommended mounting positions for the SENTRON 3VL circuit breakers are shown in the diagrams under "Technical specifications, permissible mounting positions".

3VL Molded Case Circuit Breakers

3VL Molded Case Circuit Breakers up to 1600 A

General data

Configuration

Communication

Three alternatives are available for communication.

An LCD ETU (ETU40, ETU40M or ETU42) is required in addition for the more extensive communication with COM10, or a COM20 is used with a communication-capable ETU.

If less data is required, the SIMOCODE Professional can be used as interface. All versions can be switched on and off using an optional motorized operating mechanism.

	Data transmission through COM10	Data transmission through COM20	Data transmission through SIMOCODE Pro
Transmittable data			
Commands			
Switch on/off	✓	✓	✓
Alarm and tripping memory, min./max. measured values and maintenance information	✓	✓ ²⁾	--
Operating statuses			
ON or OFF status trip position	✓	✓	✓
Event signals			
Tripped signals with tripping current and time stamp	✓	✓ ¹⁾	--
Alarm signals (e. g. overload)	--	✓	✓
Alarm signals with time stamp (e. g. overload, phase unbalance, current etc.)	✓	--	--
Threshold value warning, with time stamp (e. g. phase currents)	✓	✓ ¹⁾	--
Measured values			
Phase currents and neutral conductor current, each with min./max. value and time stamp	✓	✓ ²⁾	--
Phase currents, voltages, power	--	--	✓
Parameter values			
Read and write	✓	✓	--
Set values for SIMOCODE Pro	--	--	✓
Maintenance information			
(e. g. number of tripping operations, number of switching operations)	✓	✓	--
Device identification data			
	✓	✓	--
Time synchronization			
	✓	✓	--

✓ Available -- Not available

Function	Local Solid-state release version			Remote		SIMOCODE	Breaker Data Adapter	Breaker Data Adapter <i>Plus</i>
	TM	ETU	LCD ETU	COM10 module	COM20 module			
Functions of the communication components								
Transmission of the operating state (only ON, OFF, tripped) to the PROFIBUS	✓	✓	✓	--	--	✓	--	--
Transmission of the operating state (ON, OFF, tripped, warnings, causes of tripping, event log) to the PROFIBUS	--	✓	✓	✓	✓	--	□	□
Display of measured values (current only) and parameters in release, change parameters through display	--	--	✓	□	□	□	□	□
Transmission of maximum value of present current in %	✓	✓	✓	--	--	✓	□	□
Transmission of individual present phase currents incl. min./max. and time stamp	--	✓	✓	✓	✓ ¹⁾²⁾	--	□	□
Transmission of identification data	--	✓	✓	✓	✓	--	□	□
Transmission of switch information on HTML basis locally to a PC	--	--	✓	□	--	--	✓	✓
Transmission of switch information on HTML basis through Ethernet	--	--	✓	□	--	--	--	✓
Read out and adjust protection parameters through PROFIBUS	--	✓	✓	✓	✓	--	□	□

✓ Required

□ Function can optionally be taken over by more than one release.

□ Function can optionally be taken over by one of these adapters.

□ Not necessary for this function, optionally combinable

-- Function not available

¹⁾ Without time stamp.

²⁾ Only max. values.

3VL Molded Case Circuit Breakers

3VL Molded Case Circuit Breakers up to 1600 A

General data

Switching of DC currents

The VL160X to VL630 circuit breakers (for system protection with TM, for starter combinations, non-automatic air circuit breakers) can also be used for DC switching and protection applications.

The VL160 to VL1600 circuit breakers with solid-state releases (ETU) are not suitable for DC applications.

However, the maximum permitted DC current for each conducting path needs to be taken into account for DC switching applications.

For voltages above 250 V for VL160 to VL630, a series connection of 2 or 4 conducting paths is required.

As the current has to flow through all of the conducting paths, the following connections are recommended in order to satisfy the thermal tripping characteristics.

With DC applications, the response values of the instantaneous short-circuit releases ("I" releases) are increased by 30 to 40 %.

Recommended connection/Maximum permitted DC voltage U_e		Remarks
Circuit A	Circuit B ¹⁾	
For 3- and 4-pole circuit breakers²⁾³⁾		
250 V DC ⁴⁾ 	500 V DC ⁴⁾ 	2-pole switching (non-grounded system) If there is no possibility of a ground fault, or if every ground fault is rectified immediately (ground-fault monitoring), then the maximum permitted DC voltage is 600 V for both circuits.
500 V DC 	600 V DC 	2-pole switching (grounded system) The grounded pole is always assigned to the individual conducting path, so that there are always 2 conducting paths in series in the event of a ground fault in circuit A and 3 conducting paths in series in the event of a ground fault in circuit B.
600 V DC 	600 V DC 	1-pole switching (grounded system) The grounded pole is assigned to the unconnected conducting path.

- ¹⁾ Circuit B: A current reduction to 75 % is necessary with 4 conducting paths. The characteristic curve is also shifted by the greater temperature rise.
- ²⁾ VL160X on request.
- ³⁾ 4th pole (N) without overload and short-circuit releases, or 4th pole (N=100 %).
- ⁴⁾ With a non-grounded system, all poles must be disconnected.

3VL Molded Case Circuit Breakers

3VL Molded Case Circuit Breakers up to 1600 A

General data

Technical specifications

Type	VL160X 3VL1	VL160 3VL2	VL250 3VL3	VL400 3VL4	VL630 3VL5	VL800 3VL6	VL1250 3VL7	VL1600 3VL8
Max. rated current I_n	A 160	160	250	400	630	800	1250	1600
N pole	A 160	160	250	400	630	800	1250	1600
Rated insulation voltage U_i acc. to IEC 60947-2								
Main current paths	AC V 800	800	800	800	800	800	800	800
Auxiliary circuits	AC V 690	690	690	690	690	690	690	690
Rated impulse withstand voltage U_{imp}								
Main current paths	kV 8	8	8	8	8	8	8	8
Auxiliary circuits	kV 4	4	4	4	4	4	4	4
Rated operational voltage U_e								
IEC 50/60 Hz	AC V 690 DC ²⁾ V 500	690 600	690 600	690 600	690 600	690 600	690 600	690 600
NEMA 60 Hz	AC V 600	600	600	600	600	600	600	600
Utilization categories (IEC 60947-2)								
	A	A	A	A	A B ³⁾	A B ³⁾	A B ³⁾	A B ³⁾
Permissible ambient temperature⁴⁾								
Operation	°C -25 ... +70	-25 ... +70	-25 ... +70	-25 ... +70	-25 ... +70	-25 ... +70	-25 ... +70	-25 ... +70
Storage	°C -40 ... +80	-40 ... +80	-40 ... +80	-40 ... +80	-40 ... +80	-40 ... +80	-40 ... +80	-40 ... +80
Permissible load at various ambient temperatures								
Close to the circuit breaker, related to the rated current of the circuit breaker								
• Circuit breakers for system protection	TM/ETU Up to 50 °C %	100/100	100/100	100/100	100/100	100/100	--/100	--/100
	TM/ETU At 60 °C %	93/95	93/95	93/95	93/95	93/95	--/95	--/95
	TM/ETU At 70 °C %	86/80	86/80	86/80	86/80	86/80	--/80	--/80
• Circuit breakers for motor protection	Up to 50 °C %	100	100	100	100	100	--	--
	At 60 °C %	95	95	95	95	95	--	--
	At 70 °C %	80	80	80	80	80	--	--
• Circuit breakers for starter combinations and non-automatic circuit breakers	Up to 50 °C %	100	100	100	100	100	100	100
	At 60 °C %	93	93	93	93	93	93	93
	At 70 °C %	86	86	86	86	86	86	86
Weights of 3-pole circuit breakers								
Basic unit without solid-state release	kg --	1.5	1.6	4.2	7.8	14.2	21	27.3
Thermal-magnetic overcurrent release	kg --	0.7	0.7	1.5	1.2	--	--	--
Solid-state release	kg --	0.9	0.9	1.7	1.5	1.8	4.0	4.0
Basic unit								
• With thermal-magnetic overcurrent release	kg 2.0	2.2	2.3	5.7	9.0	--	--	--
• With solid-state release	kg --	2.4	2.5	5.9	9.3	16.0	25.0	31.3
Weights of 4-pole circuit breakers								
Basic unit without solid-state release	kg --	2.0	2.2	5.5	9.7	18.2	27.5	34.8
Thermal-magnetic overcurrent release	kg --	1.0	1.0	1.9	1.5	--	--	--
Solid-state release	kg --	1.1	1.1	2.1	2.0	2.3	6.0	6.0
Basic unit								
• With thermal-magnetic overcurrent release	kg 2.5	3.0	3.2	7.4	11.2	--	--	--
• With solid-state release	kg --	3.1	3.3	7.6	11.7	20.5	33.5	40.8
Rated short-circuit breaking capacity								
acc. to IEC 60947-2	For rated short-circuit breaking capacity see table under "Overview".							

¹⁾ Circuit breaker cannot be used for direct current.

²⁾ Rated DC data apply only for thermal-magnetic overcurrent releases.

³⁾ On request.

⁴⁾ Exception: 3VL molded case circuit breakers with TM TU: 0 °C ... 75 °C due to derating at low temperatures.

3VL Molded Case Circuit Breakers

3VL Molded Case Circuit Breakers up to 1600 A

General data

Type		VL160X 3VL1	VL160 3VL2	VL250 3VL3	VL400 3VL4	VL630 3VL5	VL800 3VL6	VL1250 3VL7	VL1600 3VL8
Endurance	Operating cycles	20000	20 000	20 000	20 000	10 000	10 000	3000	3000
Electrical endurance	Operating cycles	10000	10 000	10 000	10 000	5000	3000	1500	1500
Max. switching frequency	1/h	120	120	120	120	60	60	30	30
Connection types See "Main Connections, Basic Equipment and Options"									
Conductor cross-sections									
Box terminals ⁴⁾									
• Solid or stranded cable • Finely stranded with end sleeve • Flexible busbar	Copper only	mm ²	2.5 ... 95	2.5 ... 95	25 ... 185	50 ... 300	--	--	--
		mm ²	2.5 ... 50	2.5 ... 50	25 ... 120	50 ... 240	--	--	--
		mm	12 × 10	12 × 10	17 × 10	25 × 10	--	--	--
Connecting terminal plate for flexible busbar ³⁾		mm	--	--	--	2 units 10 × 32	--	--	--
Circular conductor terminal for cable ⁴⁾									
• Solid or stranded cable • Finely stranded with end sleeve	Cu or Al	mm ²	16 ... 70	16 ... 70	25 ... 185	50 ... 300	--	--	--
		mm ²	10 ... 50	10 ... 50	25 ... 120	50 ... 240	--	--	--
Multiple feed-in terminal ⁴⁾									
• Solid or stranded cable • Finely stranded with end sleeve	Cu or Al	mm ²	--	--	--	2 units 50 ... 120	2 units 50 ... 240	3 units 50 ... 240	4 units 50 ... 240
		mm ²	--	--	--	2 units 50 ... 95	2 units 50 ... 185	3 units 50 ... 185	4 units 50 ... 185
• Direct connection of busbars • Screw for connection with screw terminal	Cu or Al	mm	17 × 7	22 × 7	24 × 7	32 × 10	40 × 10	2 × 40 × 10	2 × 50 × 10
		M6	M6	M8	M8	M6	M8	M8	3 × 60 × 10
Conductor cross-sections for control circuits with terminal connection									
Screw terminals									
• Solid • Finely stranded with end sleeve		mm ²	0.75 ... 1.5	0.75 ... 1.5	0.75 ... 1.5	0.75 ... 1.5	0.75 ... 1.5	0.75 ... 1.5	0.75 ... 1.5
		mm ²	0.75 ... 1.0	0.75 ... 1.0	0.75 ... 1.0	0.75 ... 1.0	0.75 ... 1.0	0.75 ... 1.0	0.75 ... 1.0
For details see Mounting Instruction .									
Power loss per circuit breaker at max. rated current									
System protection	TM 0.8 ... 1.0	W	12 ... 70	15 ... 48	32 ... 80	60 ... 175	85 ... 230	--	--
System protection	ETU or LCD ETU	W	--	40	60	90	160	250	210
For starter combinations or non-automatic air circuit breaker		W	40	40	60	90	160	250	210
For motor protection		W	--	40	60	90	160	--	--
Permissible mounting position¹⁾									
Auxiliary and alarm switches									
Conventional free-air thermal current I_{th}									
	A	10	10	10	10	10	10	10	10
Rated making capacity									
	A	10	10	10	10	10	10	10	10
AC									
Rated operational voltage	V	24	48	110	230	400	600		
Rated operational current	AC-12	A	10	10	10	10	10		
	AC-15	A	6	6	6	6	3	1	
DC									
Rated operational voltage	V	24	48	110	230				
Rated operational current	DC-12	A	10	5	2.5	1			
	DC-13	A	3	1.5	0.7	0.3			
Back-up fuse/ miniature circuit breaker									
	A	10 TDz/10	10 TDz/10	10 TDz/10	10 TDz/10	10 TDz/10	10 TDz/10	10 TDz/10	10 TDz/10
Leading auxiliary switch with rotary operating mechanism									
Conventional thermal current I_{th}	A	2	2	2	2	2	2	2	2
Rated making capacity	A	2 (ind. 0.5)	2 (ind. 0.5)	2 (ind. 0.5)	2 (ind. 0.5)	2 (ind. 0.5)	2 (ind. 0.5)	2 (ind. 0.5)	2 (ind. 0.5)
Rated operational voltage	V AC	230	230	230	230	230	230	230	230
Rated operational current	A	2	2	2	2	2	2	2	2
Rated breaking capacity, inductive, p.f. = 0.7	A	0.5	0.5	0.5	0.5	0.5	0.5	0.5	0.5
Rated breaking capacity	A	2	2	2	2	2	2	2	2
Back-up fuse, quick	A	2	2	2	2	2	2	2	2
Position indicator switches									
Conventional thermal current I_{th}	A	16	16						
Rated making capacity	A	16	10						
Rated operational voltage	V AC	250	400						
Rated operational current	A	16	10						
Rated breaking capacity, inductive, p.f. = 0.7	A	4	4						
Rated breaking capacity	A	16	10						
Back-up fuse, quick	A	16	10						

¹⁾ For VL800 to VL1600 circuit breakers with guide frame in lateral mounting position. Adapter set on request.

²⁾ Permissible current load factor 0.9; only with internal accessories.

³⁾ Not for 690 V AC/600 V DC.

⁴⁾ Cross-sections according to IEC 60999.

3VL Molded Case Circuit Breakers

3VL Molded Case Circuit Breakers up to 1600 A

General data

Type	VL160X 3VL1	VL160 3VL2	VL250 3VL3	VL400 3VL4	VL630 3VL5	VL800 3VL6	VL1250 3VL7	VL1600 3VL8
Auxiliary and alarm switches								
Tripped signal switch in RCD module¹⁾								
Conventional thermal current I_{th}	A --	2	2	2	--	--	--	--
Rated making capacity	A --	2	2	2	--	--	--	--
Rated operational voltage	V AC --	250	250	250	--	--	--	--
Rated operational current	A --	2	2	2	--	--	--	--
Rated breaking capacity, inductive, p.f. = 0.7	A --	0.5	0.5	0.5	--	--	--	--
Rated breaking capacity	A --	2	2	2	--	--	--	--
Back-up fuse, quick	A --	2	2	2	--	--	--	--
Auxiliary releases								
	Group 1: VL160X to VL400				Group 2: VL630 to VL1600			
Undervoltage releases								
Response voltage:								
Release (circuit breaker is tripped)	V 0.35 ... 0.70 × U_s				0.35 ... 0.70 × U_s			
Pick-up (circuit breaker can be closed)	V 0.85 ... 1.1 × U_s				0.85 ... 1.1 × U_s			
Power consumption (uninterrupted duty) at:								
AC 50/60 Hz 24 V	VA 1.4				1.2			
AC 50/60 Hz 110 ... 127 V	VA 1.0				1.8			
AC 50/60 Hz 220 ... 250 V	VA 1.0				1.8			
AC 50/60 Hz 208 V	VA 1.0				1.8			
AC 50/60 Hz 277 V	VA 1.0				1.8			
AC 50/60 Hz 380 ... 415 V	VA 1.0				1.8			
AC 50/60 Hz 440 ... 480 V	VA 1.0				1.8			
AC 50/60 Hz 500 ... 525 V	VA 1.0				1.8			
AC 50/60 Hz 600 V	VA 1.0				1.8			
12 V DC	W 0.8				1.5			
24 V DC	W 0.8				1.5			
48 V DC	W 0.8				1.5			
60 V DC	W 0.8				1.5			
110 ... 127 V DC	W 0.8				1.5			
220 ... 250 V DC	W 0.8				1.5			
Max. opening time	ms 50				50			
Shunt release								
Response voltage:								
Pick-up (circuit breaker is tripped)	V U_s ... 1.1				U_s ... 1.1			
Power consumption (short time) at:								
AC 50/60 Hz 24 V	VA 310				330			
AC 50/60 Hz 48 ... 60 V	VA 335 ... 465				380 ... 460			
AC 50/60 Hz 110 ... 127 V	VA 470 ... 630				330 ... 430			
AC 50/60 Hz 208 ... 277 V	VA 585 ... 1000				520 ... 800			
AC 50/60 Hz 380 ... 600 V	VA 180 ... 500				228 ... 750			
24 V DC	W 360				385			
48 ... 60 V DC	W 380 ... 590				480 ... 720			
110 ... 127 V DC	W 506 ... 680				362 ... 424			
220 ... 250 V DC	W 470 ... 580				418 ... 476			
Max. opening time	ms 50				50			
Max. duration of operational voltage	s Interrupts automatically, less than 10 ms				Interrupts automatically, less than 10 ms			
Time-delay device for undervoltage release								
Rated control supply voltage U_s	V AC/DC 220 ... 250				220 ... 250			
Control voltage for undervoltage release	V DC 220 ... 250				220 ... 250			
Conductor cross-sections								
Finely stranded with end sleeve	mm ² 2 × (0.5 ... 1.5)				2 × (0.5 ... 1.5)			
Solid	mm ² 2 × (0.5 ... 1.5)				2 × (0.5 ... 1.5)			
Delay time/connection								
Undervoltage release	s 3/-- s 6/Jumper Y2-Y1				1.5/-- 3/Jumper Y2-Y1			
Undervoltage release and auxiliary relay (3RH11)	s 0.6/-- s 1.2/Jumper Y2-Y1				0.3/-- 0.6/Jumper Y2-Y1			

¹⁾ Max. DC rated operational voltage 125 V, minimum load 50 mA at 5 V DC.

3VL Molded Case Circuit Breakers

3VL Molded Case Circuit Breakers up to 1600 A

General data

Type		VL160X 3VL1	VL160 3VL2	VL250 3VL3	VL400 3VL4	VL630 3VL5	VL800 3VL6	VL1250 3VL7	VL1600 3VL8
Motorized operating mechanisms		x	x	x	--	--	--	x	x
Motorized operating mechanism with energy store (synchronizable)		x	x	x	x	x	x	--	--
Motorized operating mechanisms									
Power consumption	VA/W	< 100	< 100	< 100	--	--	--	< 250	< 250
Rated control supply voltage U_s	AC 50/60 Hz	42	110-127/220-240		--	--	--	42-48/60	110-127/220-250
	V DC	24/48	60/110-127/220		--	--	--	24/42-48/60	110-127/220-250
DIAZED fuses (gG operational class, characteristic slow)	A	4	2	--	--	--	--	4	2
Miniature circuit breaker (C characteristic acc.to EN 60898)	A	4	2	--	--	--	--	4	2
Operating range	V	0.85 ... 1.1 x U_s	0.85 ... 1.1 x U_s	0.85 ... 1.1 x U_s	--	--	--	0.85 ... 1.1 x U_s	0.85 ... 1.1 x U_s
Minimum command duration at U_s	ms	50	50	50	--	--	--	50	50
Max. command duration, depends on circuit ¹⁾		Non-maintained or continuous command			--	--	--	Non-maintained or continuous command	
Total make-time	s	< 1	< 1	< 1	--	--	--	< 5	< 5
Break-time	s	< 1	< 1	< 1	--	--	--	< 5	< 5
Interval time between OFF and ON commands	s	> 2	> 2	> 2	--	--	--	> 5	> 5
Interval time between ON and OFF commands	s	> 2	> 2	> 2	--	--	--	> 5	> 5
Max. permissible switching frequency	1/h	120	120	120	--	--	--	30	30
Motorized operating mechanism with energy store (synchronizable)									
Power consumption	VA/W	< 100	< 100	< 100	< 200	< 250	< 250	--	--
Rated control supply voltage U_s	AC 50/60 Hz	42-48/60			110-127/220-250			--	--
	V DC	24/42-48/60			110-127/220-250			--	--
DIAZED fuses (gG operational class, characteristic slow)	A	4	--	--	2	--	--	--	--
Miniature circuit breaker (C characteristic acc. to EN 60898)	A	4	--	--	2	--	--	--	--
Operating range	V	0.85 ... 1.1 x U_s	0.85 ... 1.1 x U_s	0.85 ... 1.1 x U_s	0.85 ... 1.1 x U_s	0.85 ... 1.1 x U_s	0.85 ... 1.1 x U_s	--	--
Minimum command duration at U_s	ms	50	50	50	50	50	50	--	--
Max. command duration, depends on circuit ¹⁾		Non-maintained or continuous command						--	--
Total make-time	ms	< 100	< 100	< 100	< 100	< 100	< 100	--	--
Break-time	s	< 5	< 5	< 5	< 5	< 5	< 5	--	--
Interval time between OFF and ON commands	s	> 5	> 5	> 5	> 5	> 5	> 5	--	--
Interval time between ON and OFF commands	s	> 1	> 1	> 1	> 1	> 1	> 1	--	--
Max. permissible switching frequency	1/h	120	120	120	120	60	60	--	--

x Available

-- Not available

¹⁾ Changeover contact also permissible, note dead times between ON and OFF commands.

3VL Molded Case Circuit Breakers

3VL Molded Case Circuit Breakers up to 1600 A

General data

Space requirements above arc chutes

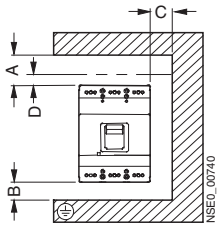

Arcing spaces

Minimum clearances from adjacent grounded parts and from non-insulated live parts.

Plain conductors and busbars must be insulated with phase barriers within the arcing space.

The specific mounting instructions for the various sizes must be observed for plain conductors and busbars outside the arcing space.

[For mounting instructions and manual refer to the Internet](#)

[Manual for the SENTRON 3VL circuit breaker](#)

This manual contains additional technical information, covering a product description, mode of operation, electrical wiring system and retrofitting.

The manual and operating instructions are available in PDF format at:

<http://www.siemens.com/lowvoltage/manuals>

Circuit breakers	Switching capacity	Minimum enclosure volume	A			B		C		D	
			≤ 415 V	>415 ... 690 V	>415 ... 690 V	≤ 690 V	≤ 690 V	≤ 690 V	≤ 690 V	≤ 690 V	
Type		m ³	Without/with terminal cover	Without terminal cover	With terminal cover						
VL160X	Standard High	0.011	35	70	35	25	25			35	
VL160	Standard High Very high	0.011	50	100	50	25	25			35	
VL250	Standard High Very high	0.015	50	100	50	25	25			35	
VL400	Standard High Very high	0.036	50	100	50	25	25			35	
VL630	Standard High Very high	0.18	50	100	50	25	25			35	
VL800	Standard High Very high	0.22	50	100	50	25	25			35	
VL1250	Standard High Very high	0.22	70	100	70	30	30			50	
VL1600	Standard High Very high	0.264	100	100	100	100	30			100	

Definition of the permissible safety clearances

Clearance between

- A: circuit breaker and busbars (bare metal and grounded metal); terminal cover required above 600 V AC, 500 V DC
- B: circuit breaker connection and floor
- C: side of the circuit breaker and the side panels (bare metal and grounded metal)
- D: circuit breaker and non-conducting parts with an insulation thickness of at least 3 mm (insulator, insulated busbar, painted plate)

3VL Molded Case Circuit Breakers

3VL Molded Case Circuit Breakers up to 1600 A

General data

General criteria for the selection of current transformers for measurement purposes



4NC53 current transformer

Standards	IEC 60044-1, EN 60044-1
Window-type current transformers	The conductor to be measured (busbar or cable) is passed through the window opening and constitutes the primary circuit of the window-type current transformer. Pin-wound transformers: An economical solution especially for small primary currents of 5 A to 75 A is achieved when the conductor to be measured is pin-wound several times.
Rated primary current I_{pn}	Current transformers can be continuously loaded with 1.3 times the rated primary current (I_{pn}).
Rated secondary current I_{sn}	
1 A	Particularly suitable for longer measuring leads. Cable losses of only 4% in contrast to 5 A current transformers.
5 A	5 A current transformers generate 25 times the power losses on measuring leads as compared with 1 A current transformers. These stray losses result in higher power in the case of long cables. Only recommended for use with short measuring leads.
Accuracy class	
Class 1	Operation measurement, internal metering Current error $\pm 1\%$ at $1 \times I_{pn}$ and $1.2 \times I_{pn}$
Class 3	Coarse measurement Current error $\pm 3\%$ at $0.5 \times I_{pn}$ and $1.2 \times I_{pn}$
Rated power P_n	The rated power of transformers is specified in VA. The actual load rating should be similar to the rated power; a lower actual load rating (underburden) increases the overcurrent factor and measuring devices may be damaged in case of a short-circuit, a higher actual load rating (overburden) has a negative effect on the accuracy. With a frequency of 60 Hz the rated power increases to 1.2 times. With $16^{2/3}$ Hz the output power decreases to $1/3$ of the rated power.
Maximum voltage for equipment U_m	This is the rms value of the maximum voltage between the conductors of a system. For this voltage the insulation must be rated at normal operating conditions. 4NC5 current transformers are suitable for 720 V.
Overcurrent limiting factor FS	The overcurrent limiting factor is expressed using the characters FS and a factor, e. g. FS5 or FS10. When a short-circuit current flows through the primary winding of a current transformer, the load on the measuring devices connected to the current transformer is the lower the smaller the overcurrent limiting factor is.
Rated short-time thermal current I_{th}	The rated short-time thermal current I_{th} is the rms value of the primary current with a duration of one second, whose heat effect the current transformer can resist without being damaged in the event of a short-circuited secondary winding.
Rated impulse current I_{dyn}	The rated impulse current I_{dyn} is the highest instantaneous value of the current after a short-circuit whose force the current transformer can resist without being damaged. The rated impulse current is specified as peak value.

3VL Molded Case Circuit Breakers

3VL Molded Case Circuit Breakers up to 1600 A

General data

Standards		IEC 60044-1, EN 60044-1
Rated primary current I_{pn}	A	50 ... 1500, 5 ... 75, for use as pin-wound transformer for low currents
Rated secondary current I_{sn}	A	1 or 5
Maximum voltage for equipment U_m	V	720
Frequency	Hz	50 ... 60
Rated overcurrent limiting factor FS		FS5
Max. uninterrupted current		$1.2 \times I_{pn}$
Rated short-time thermal current I_{th}		$60 \times I_{pn}$
Rated impulse current I_{dyn}		$2.5 \times I_{th}$ or $150 \times I_{pn}$
Accuracy class		1 (3)
Ambient temperature	°C	+55 at $1.0 \times I_{pn}$ °C +40 at $1.2 \times I_{pn}$ °C -10 minimum value
Max. busbar temperature	°C	+120
Molded-plastic class		E (max. 120 °C continuously)
Insulation		Thermoplast enclosure, halogen-free
Test voltage	kV	3 AC
Secondary terminals		Double terminals using M4 captive screws, finger-safe to EN 61140
Solid	mm ²	$2 \times (2.5 \dots 6)$
Two-wire	mm ²	$2 \times (1.5 \dots 4)$
Terminals with same polarity		Primary → secondary K/P1 → k/S1 L/P2 → l/S2
Mounting		Either busbar or foot mounting

3VL Molded Case Circuit Breakers

3VL Molded Case Circuit Breakers up to 1600 A

Project planning aids

Characteristic curves

- General information:** The indicated tripping values for the inverse-time delayed solid-state releases (thermal overload releases, "L" releases) are mean values taken from the spread of all setting ranges from the cold state and under even load conditions on the conducting paths. The tripping characteristics of the instantaneous (electromagnetic) short-circuit releases ("I" releases) are based on the phase rated current I_n , which also represents the upper value of the setting range on circuit breakers with adjustable thermal overload releases. With a lower operational current there is a correspondingly higher multiple for the tripping current of the "I" releases.

The shown characteristic curve for the circuit breaker relates to a specific setting range. It is, however, also valid as a schematic representation of circuit breakers with other current ranges.

"L" = Thermal release.

"I" = Instantaneous (electromagnetic) short-circuit release

The time/current characteristic, the current limiting characteristics and the I^2t characteristic curves were determined according to IEC 60947 and EN 60947.

The time/current characteristic of the inverse-time delayed overload release (thermal overload releases, L overload release) for DC and AC with a frequency of 50/60 Hz.

- For thermomagnetic releases (TM) the following applies:

The characteristic curves apply to the cold state; at operating temperature, the tripping times of the thermal releases are reduced to approximately 25 %.

Under normal operating conditions, all three poles of the device must be loaded. The three main current paths must be connected in series in order to protect single-phase or DC loads.

- Tripping characteristic curves of the SENTRON VL160, VL250, VL400 and VL630 circuit breakers for motor/generator protection with solid-state releases.

The tripping times of the inverse-time delayed solid-state releases apply to the non-preloaded (cold) state. In the operating/warm state (after application of a load at the rated current), the tripping times are reduced to approx. 33 %. After a tripping operation due to overcurrent, the tripping times are reduced in accordance with the dynamic tripping response (see diagram), as a result of which a cooling time of a few minutes is required before the next motor start.

Time/current characteristic curves, current limiting characteristic curves and I^2t curves can be ordered from "Technical Assistance" (e-mail: technical-assistance@siemens.com) or downloaded from the following Internet site:

<http://www.siemens.com/lowvoltage/characteristics>

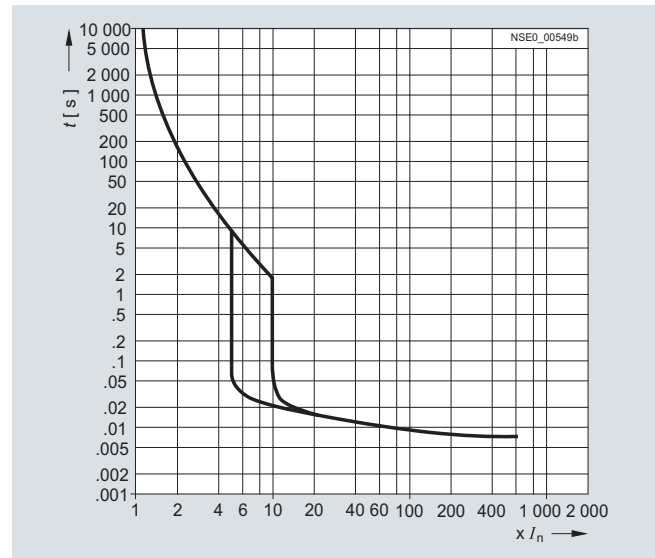

Schematic representation of the time/current characteristic curve for SENTRON VL160 circuit breakers for system protection, I_{cu} 100 kA max. at 415 V; adjustable "I" release.

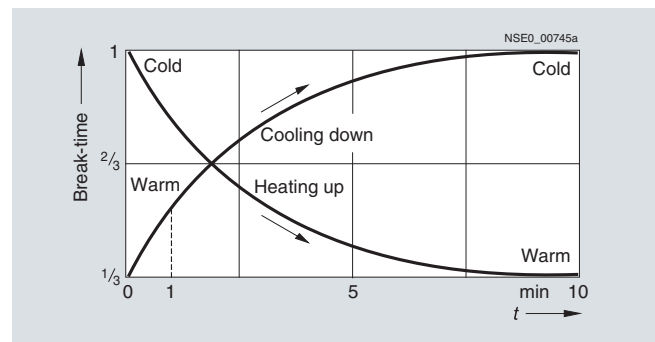

Dynamic tripping response (thermal image)

3VL Molded Case Circuit Breakers

3VL Molded Case Circuit Breakers up to 1600 A

Project planning aids

Dimensional drawings

VL160X (3VL1), VL160 (3VL2) and VL250 (3VL3), 3- and 4-pole, up to 250 A

Circuit breakers

SENTRON VL160X (3VL1) circuit breakers

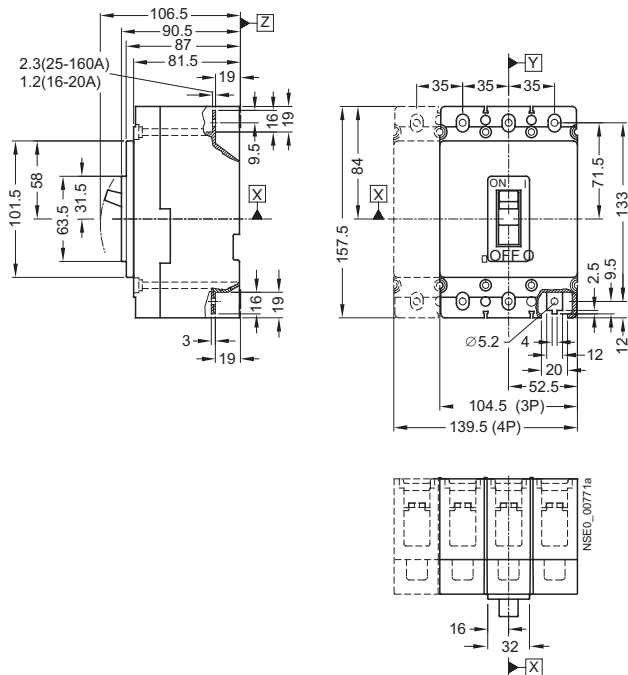

Circuit breaker installation instructions

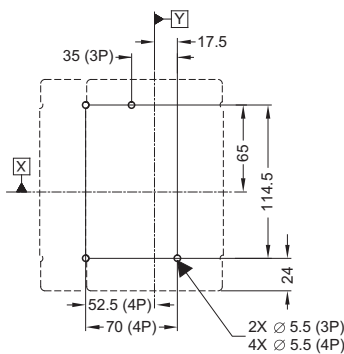

SENTRON VL160/VL250 (3VL2/3VL3) SENTRON VL160 (3VL2) circuit breakers

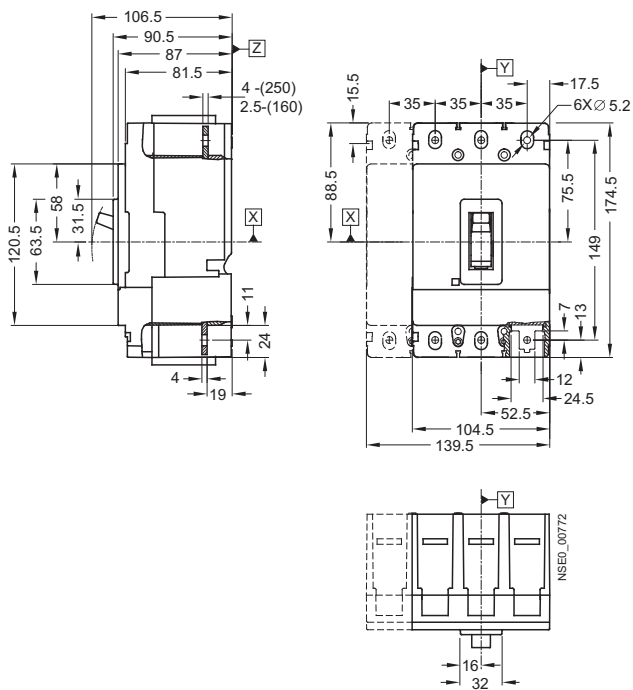

SENTRON VL250 (3VL3) circuit breakers

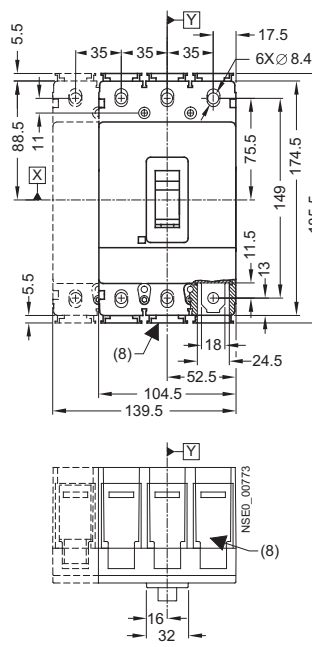

SENTRON VL160 and VL250 (3VL2 and 3VL3) circuit breakers installation instructions

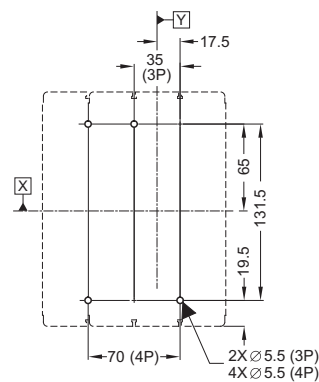

Note:
The 5.5 mm extension at each end of the SENTRON VL250 (3VL3) circuit breaker only applies when using box terminals or circular conductor terminals (8).

3VL Molded Case Circuit Breakers

3VL Molded Case Circuit Breakers up to 1600 A

Project planning aids

VL160X (3VL1), VL160 (3VL2) and VL250 (3VL3), 3- and 4-pole, up to 250 A

Operating mechanisms

Motorized operating mechanism with stored-energy mechanism

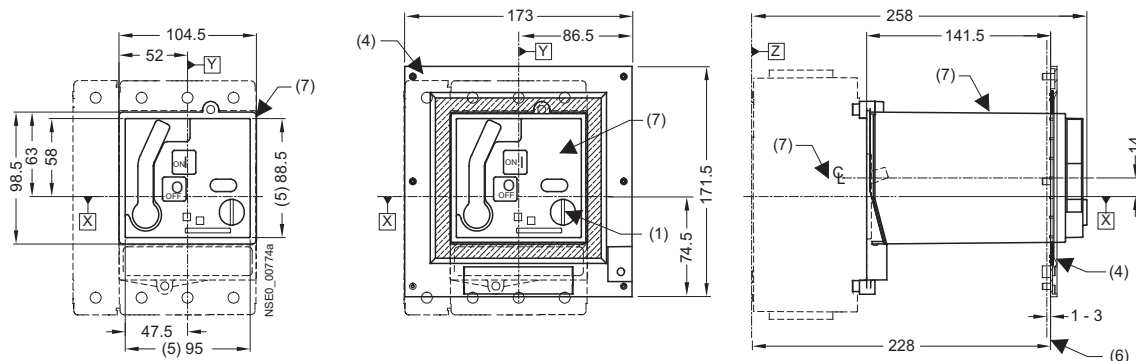

Motorized operating mechanism for VL160X (3VL1)

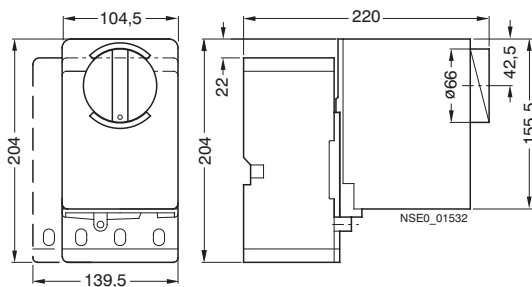

Motorized operating mechanism for VL160 (3VL2) and VL250 (3VL3)

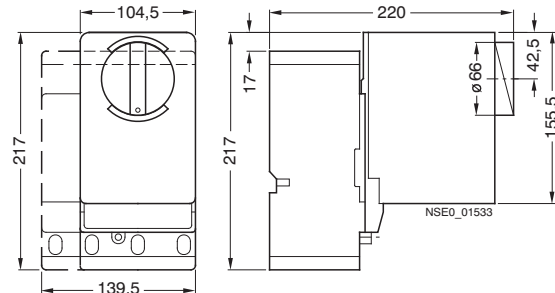

Front-operated rotary operating mechanism

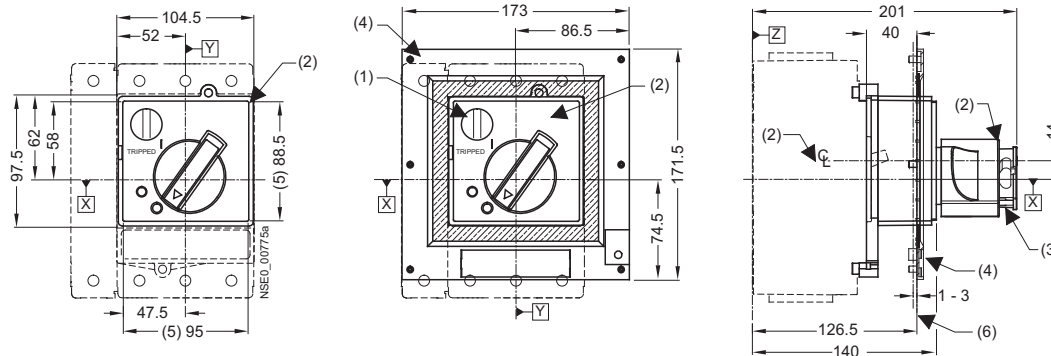

- (1) Safety locks
- (2) Front-operated rotary operating mechanism
- (3) Padlock
- (4) Masking frame for door cut-out (for circuit breaker with operating mechanism)
- (5) Step for cover
- (6) Outside surface of cabinet door
- (7) Motorized operating mechanism with stored-energy mechanism
- (8) Terminal insulation

3VL Molded Case Circuit Breakers

3VL Molded Case Circuit Breakers up to 1600 A

Project planning aids

VL160X (3VL1), VL160 (3VL2) and VL250 (3VL3), 3- and 4-pole, up to 250 A

Terminals and phase barriers

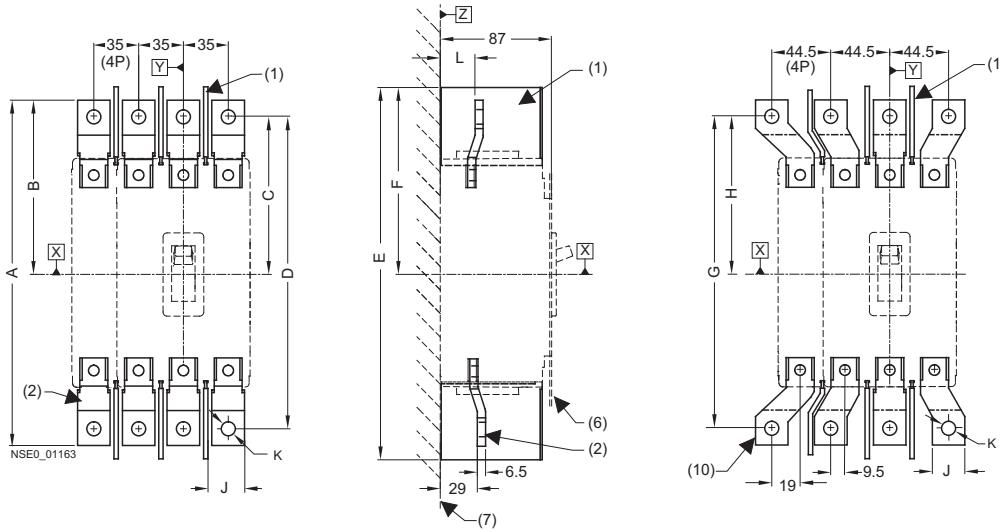

Type	A	B	C	D	E	F	G	H	J	K	L
VL160X (3VL1)	242	126	116	222	266.5	138.5	222	116	20	7	27
VL160 (3VL2)	258	130	120	238	283.5	143	238	120	20	7	27
VL250 (3VL3)	263.5	133	120	238	283.5	143	238	120	22	11	29

- (1) Phase barrier
- (2) Front connecting bars
- (3) Terminal covers (standard)
- (4) Threaded rear terminals, threaded bolt (long)
- (5) Threaded rear terminals, threaded bolt (short)
- (6) Outside surface of cabinet door
- (7) Installation level
- (8) Rear flat connector (long)
- (9) Rear flat connector (short)
- (10) Flared front busbar connecting bars

Circuit breaker with rear terminals – long and short

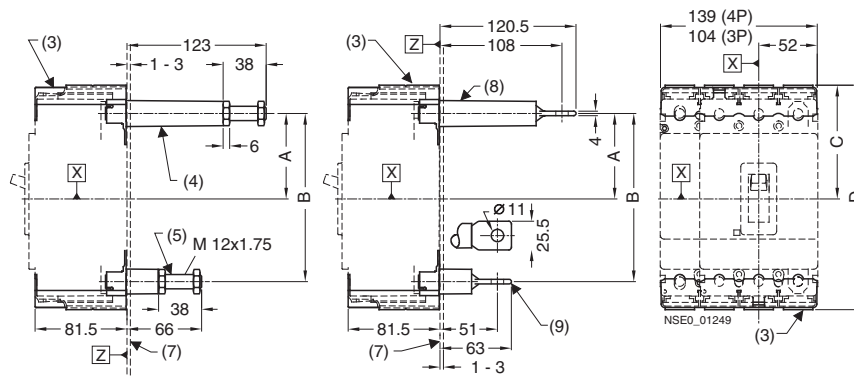

Type	A	B	C	D
VL160X (3VL1)	71.5	133	96	182
VL160 (3VL2)	75.5	149	101	199
VL250 (3VL3)	75.5	149	101	199

3VL Molded Case Circuit Breakers

3VL Molded Case Circuit Breakers up to 1600 A

Project planning aids

VL160X (3VL1), VL160 (3VL2) and VL250 (3VL3), 3- and 4-pole, up to 250 A

Terminal covers

Terminal covers, standard

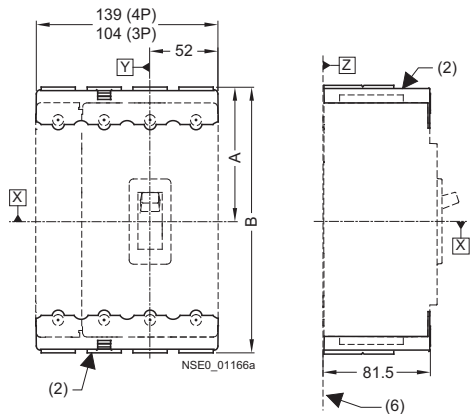

- (1) Front connecting bars
- (2) Terminal covers (standard)
- (3) Terminal covers (extended)
- (4) Masking frame for door cut-out
(for circuit breaker with toggle lever)
- (5) Outside surface of cabinet door
- (6) Installation level

Type	A	B	C	D
VL160X (3VL1)	96	182	326.5	168.5
VL160 (3VL2)	101	199	343	173
VL250 (3VL3)	101	199	343	173

Extended terminal covers

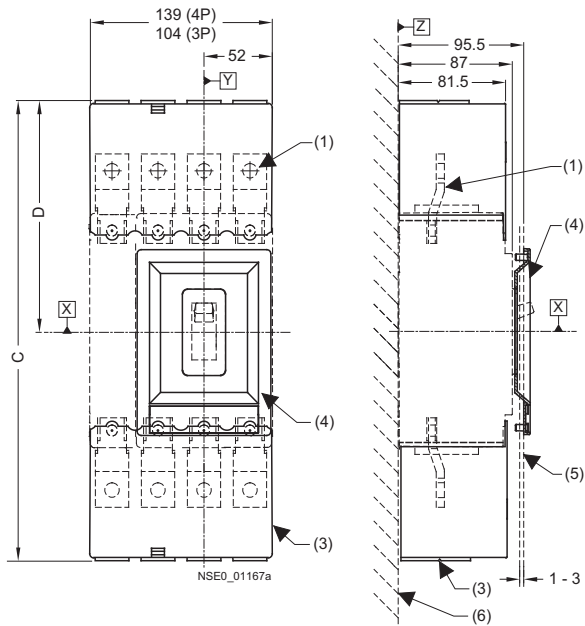

16

3VL Molded Case Circuit Breakers

3VL Molded Case Circuit Breakers up to 1600 A

Project planning aids

VL160X (3VL1), VL160 (3VL2) and VL250 (3VL3), 3- and 4-pole, up to 250 A

Locking devices for toggle levers

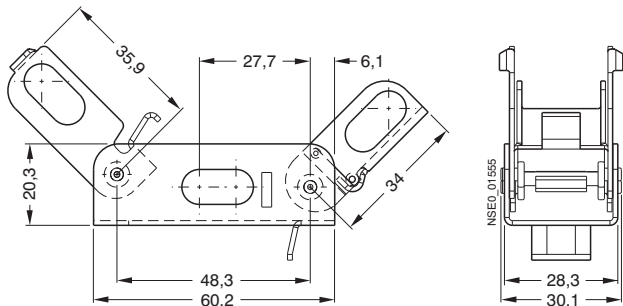

Rear interlocking modules

Rear interlocking module for plug-in/withdrawable circuit breakers, with front connection, without/with RCD module (withdrawable version only without RCD module)

For more detailed dimensional drawings see "Mounting Instructions for Rear Interlocking Module".

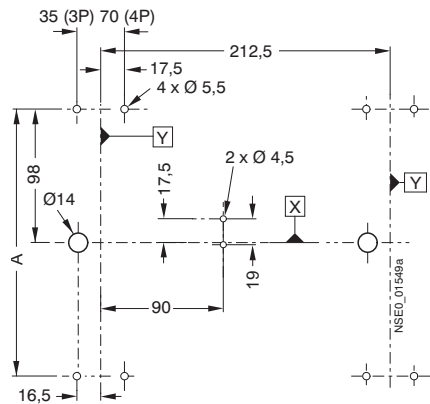

Type		A
Without RCD module	VL160X (3VL1),	194
	VL160 (3VL2),	
	VL250 (3VL3)	
With RCD module – only "plug-in version"	VL160X (3VL1),	315
	VL160 (3VL2),	
	VL250 (3VL3)	

Rear interlocking module

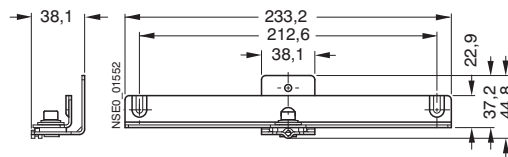

Mounting plate, example 1, not included in scope of supply

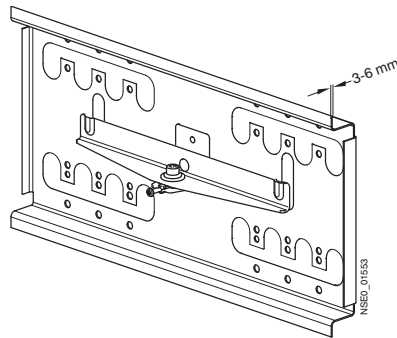

Mounting plate, example 2, not included in scope of supply

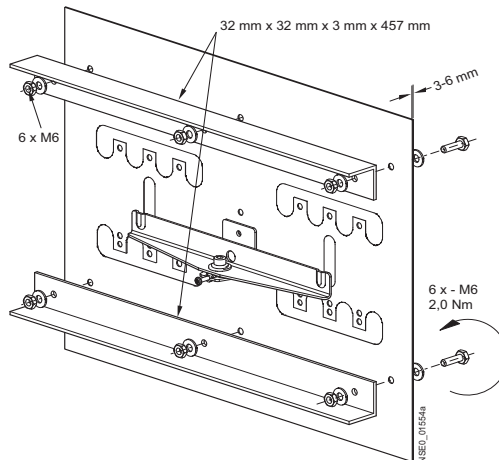

3VL Molded Case Circuit Breakers

3VL Molded Case Circuit Breakers up to 1600 A

Project planning aids

VL160X (3VL1), VL160 (3VL2) and VL250 (3VL3), 3- and 4-pole, up to 250 A

Accessories

Circuit breaker with door-coupling rotary operating mechanism

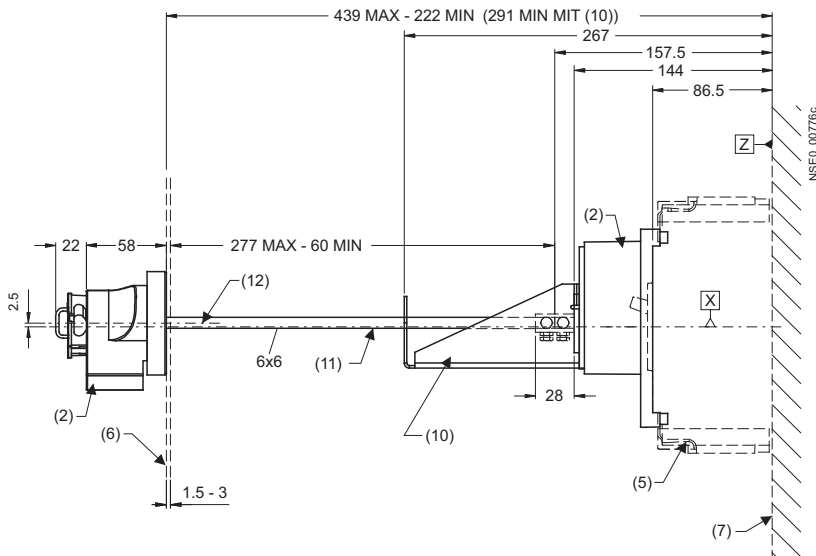

Masking frame for door cut-out for circuit breaker with toggle lever

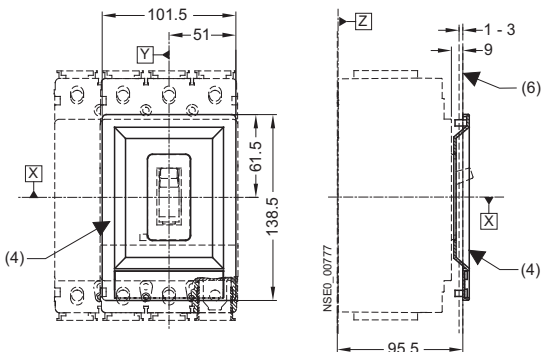

Masking frame for door cut-out for circuit breaker with operating mechanism

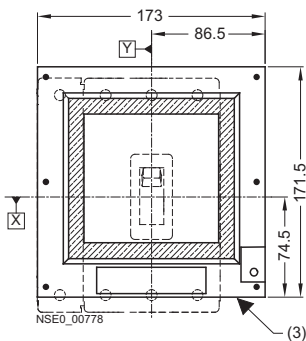

- (2) Door-coupling rotary operating mechanism
- (3) Masking frame for door cut-out (for circuit breaker with operating mechanism)
- (4) Masking frame for door cut-out (for circuit breaker with toggle lever)
- (5) Terminal covers
- (6) Outside surface of cabinet door
- (7) Installation level
- (10) Support bracket
- (11) Extension
- (12) Center line of drive shaft

3VL Molded Case Circuit Breakers

3VL Molded Case Circuit Breakers up to 1600 A

Project planning aids

VL160X (3VL1), VL160 (3VL2) and VL250 (3VL3), 3- and 4-pole, up to 250 A

Door cut-outs

Door cut-out for toggle lever (without masking frame)

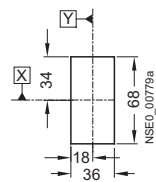

Door cut-out for front-operated rotary operating mechanism and motorized operating mechanism with stored-energy mechanism (without masking frame)

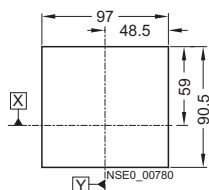

Door cut-out for door-coupling rotary operating mechanism

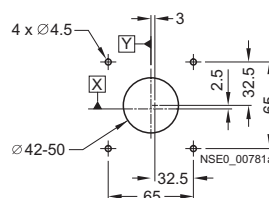

Door cut-out for toggle lever (with masking frame)

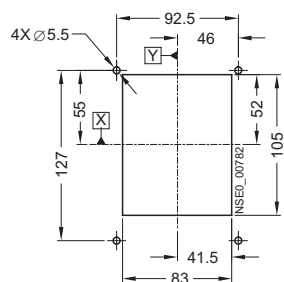

Door cut-out for front-operated rotary operating mechanism, motorized operating mechanism with stored-energy mechanism and extended escutcheon (with masking frame)

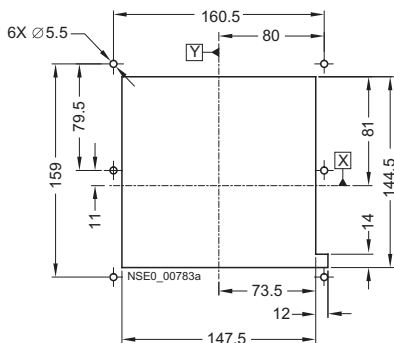

Hole pattern and cut-out for plug-in base with rear connecting bars

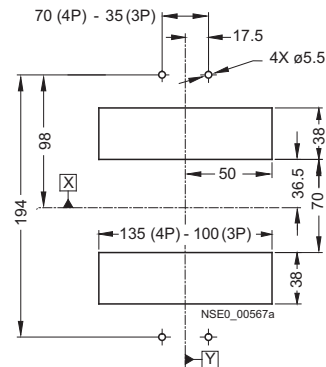

Hole pattern and cut-out for rear terminals

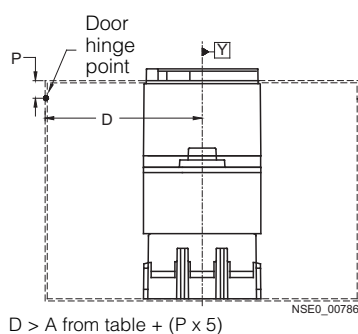
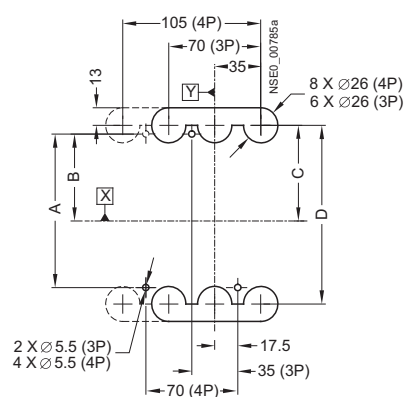

D > A from table + (P x 5)

Note:
A minimum distance between reference point Y and the door hinge is required for the door cut-outs.

Type	A	B	C	D
VL160X (3VL1)	114.5	65	71.5	133
VL160 (3VL2)	131.5	65	75.5	149
VL250 (3VL3)	131.5	65	75.5	149

Combination	A
Circuit breaker only	100
Circuit breaker + plug-in base + motorized operating mechanism with stored-energy mechanism	100
Circuit breaker + plug-in base + front-operated rotary operating mechanism	200
Circuit breaker + withdrawable version	200

3VL Molded Case Circuit Breakers

3VL Molded Case Circuit Breakers up to 1600 A

Project planning aids

VL160X (3VL1), VL160 (3VL2) and VL250 (3VL3), 3- and 4-pole, up to 250 A

Plug-in bases and accessories

Plug-in base with front connecting bars

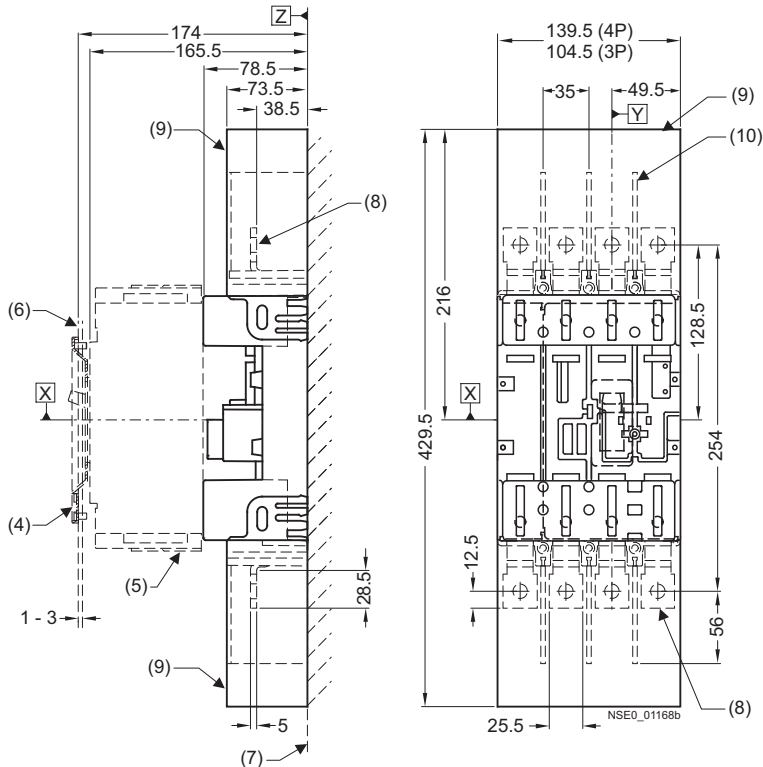

Hole pattern for plug-in base with front connecting bars

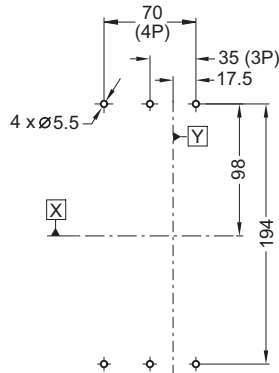

Plug-in base with rear flat bar connection

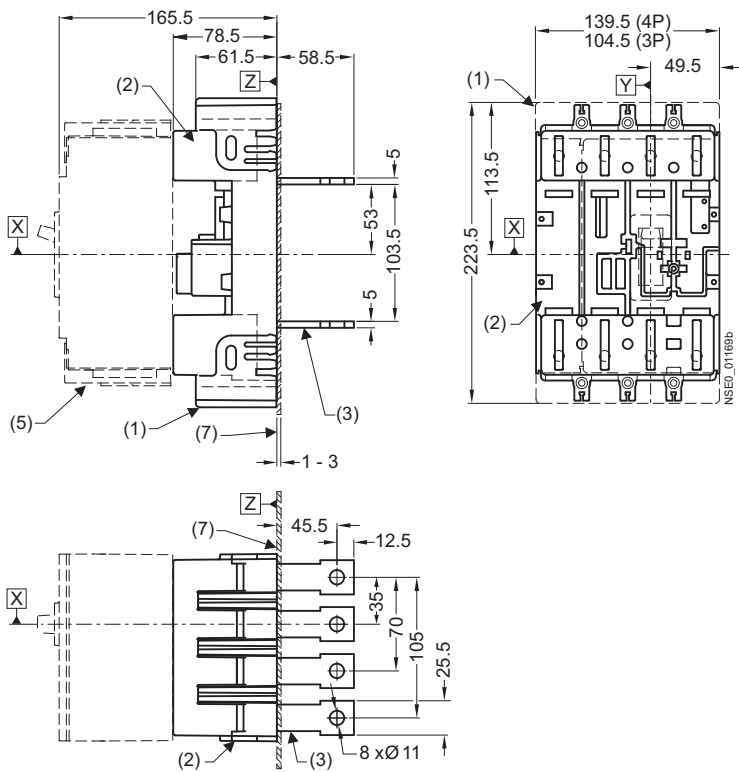

- (1) Plug-in base with rear terminal covers
- (2) Plug-in base
- (3) Plug-in base with rear flat bar connection
- (4) Masking frame for door cut-out (for circuit breaker with toggle lever)
- (5) Terminal covers (standard)
- (6) Outside surface of cabinet door
- (7) Installation level
- (8) Plug-in base with front connecting bars
- (9) Plug-in base with terminal covers on the front
- (10) Phase barriers

3VL Molded Case Circuit Breakers

3VL Molded Case Circuit Breakers up to 1600 A

Project planning aids

VL160X (3VL1), 3- and 4-pole, up to 160 A

Plug-in bases and accessories

SENTRON VL160X (3VL1) circuit breakers with motorized operating mechanism with stored-energy mechanism, mounted on plug-in base

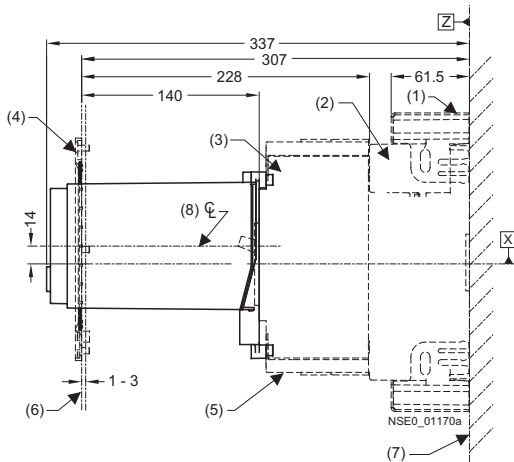

- (1) Plug-in base with terminal covers
- (2) Plug-in base
- (3) Circuit breaker
- (4) Masking frame for door cut-out
(for circuit breaker with operating mechanism)
- (5) Terminal covers (standard)
- (6) Outside surface of cabinet door
- (7) Installation level
- (8) Motorized operating mechanism with stored-energy mechanism
- (9) Front-operated rotary operating mechanism

SENTRON VL160X (3VL1) circuit breakers with front-operated rotary operating mechanism mounted on plug-in base

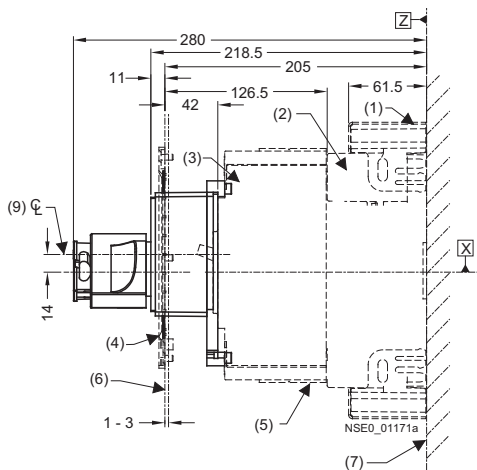

90° angle connecting adapter

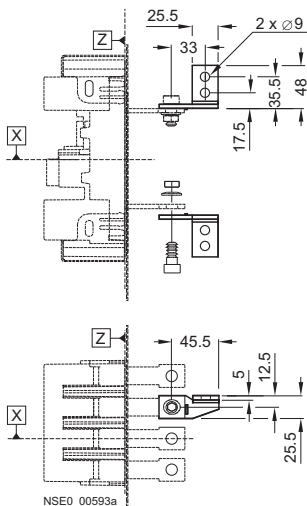

3VL Molded Case Circuit Breakers

3VL Molded Case Circuit Breakers up to 1600 A

Project planning aids

VL160 (3VL2) and VL250 (3VL3), 3- and 4-pole, up to 250 A

Withdrawable version and accessories

SENTRON VL160 (3VL2) and VL250 (3VL3) circuit breakers with motorized operating mechanism with stored-energy mechanism (connected position)

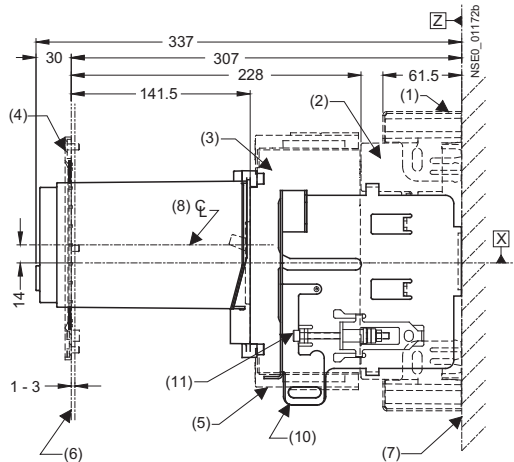

SENTRON VL160 (3VL2) and VL250 (3VL3) circuit breakers with motorized operating mechanism with stored-energy mechanism (disconnected position)

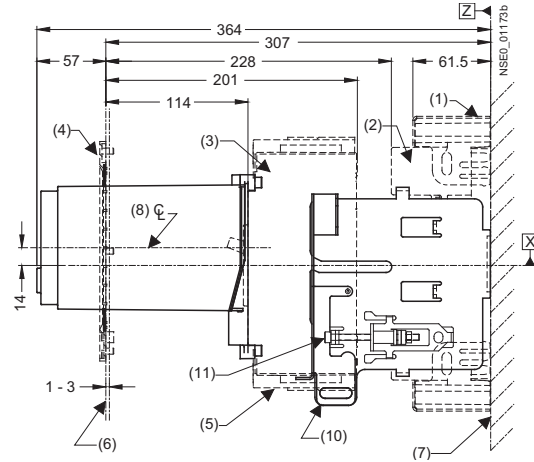

SENTRON VL160 (3VL2) and VL250 (3VL3) circuit breakers with front-operated rotary operating mechanism (connected position)

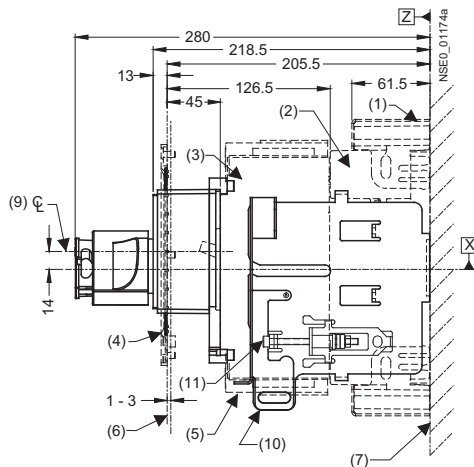

SENTRON VL160 (3VL2) and VL250 (3VL3) circuit breakers with front-operated rotary operating mechanism (disconnected position)

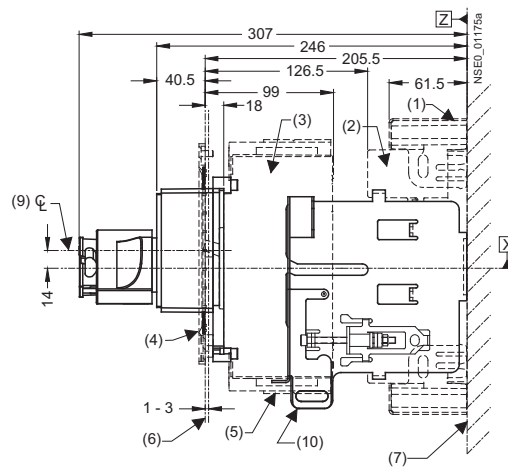

- (1) Plug-in base with terminal covers
- (2) Plug-in base
- (3) Circuit breaker
- (4) Masking frame for door cut-out
(for circuit breaker with operating mechanism)
- (5) Terminal covers (standard)
- (6) Outside surface of cabinet door
- (7) Installation level
- (8) Motorized operating mechanism with stored-energy mechanism
- (9) Front-operated rotary operating mechanism
- (10) Locking device for racking mechanism
- (11) Racking mechanism

3VL Molded Case Circuit Breakers

3VL Molded Case Circuit Breakers up to 1600 A

Project planning aids

VL160 (3VL2) and VL250 (3VL3), 3- and 4-pole, up to 250 A

Withdrawable version and accessories

SENTRON VL160 (3VL2) and VL250 (3VL3) circuit breakers with extended escutcheon (connected position)

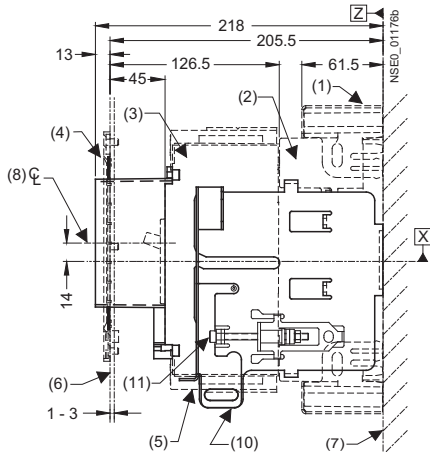

SENTRON VL160 (3VL2) and VL250 (3VL3) circuit breakers with extended escutcheon (disconnected position)

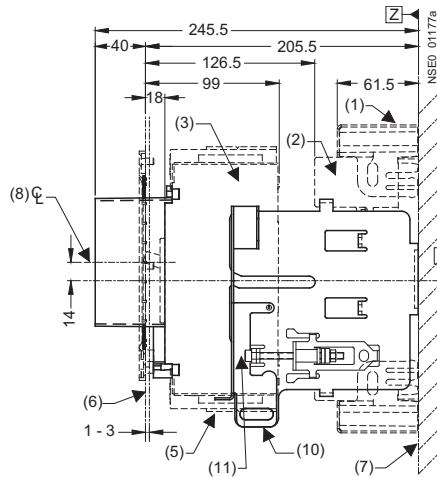

Dimensions of extended escutcheon

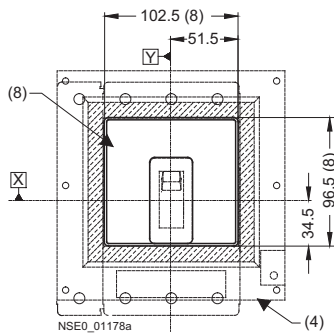

- (1) Plug-in base with terminal covers
- (2) Plug-in base
- (3) Circuit breaker
- (4) Masking frame for door cut-out
(for circuit breaker with operating mechanism)
- (5) Terminal covers (standard)
- (6) Outside surface of cabinet door
- (7) Installation level
- (8) Extended escutcheon
- (10) Locking device for racking mechanism
- (11) Racking mechanism

Dimensions of withdrawable version

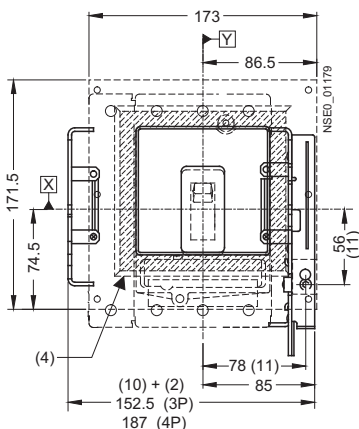

3VL Molded Case Circuit Breakers

3VL Molded Case Circuit Breakers up to 1600 A

Project planning aids

VL400 (3VL4), 3- and 4-pole, up to 400 A

Circuit breakers

SENTRON VL400 (3VL4) circuit breakers

Circuit breaker installation instructions

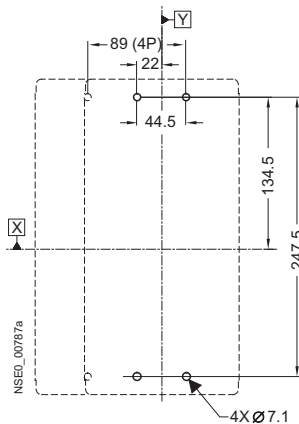
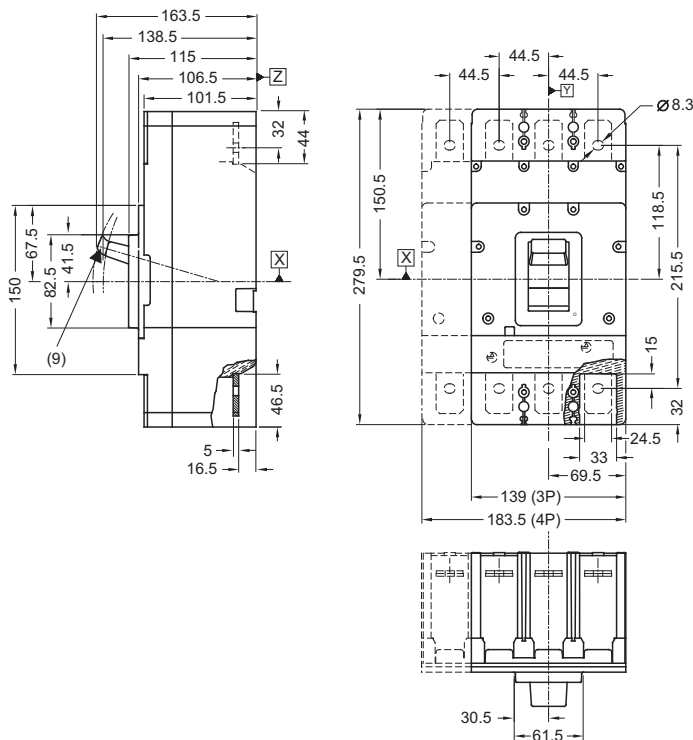

Motorized operating mechanism with stored-energy mechanism

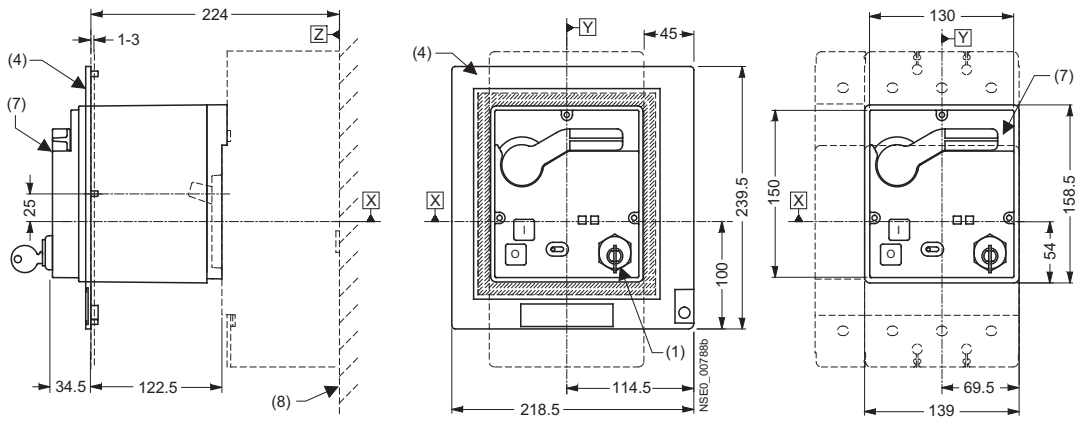

Front-operated rotary operating mechanism

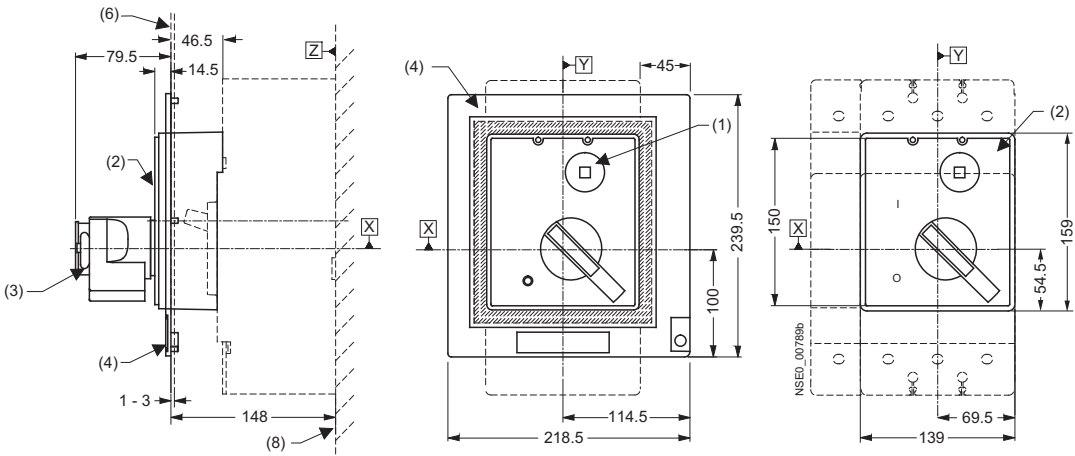

- (1) Safety lock
- (2) Front-operated rotary operating mechanism
- (3) Padlock
- (4) Masking frame for door cut-out (for circuit breaker with operating mechanism)
- (6) Outside surface of cabinet door
- (7) Motorized operating mechanism with stored-energy mechanism
- (8) Installation level
- (9) Toggle lever extension

16

3VL Molded Case Circuit Breakers

3VL Molded Case Circuit Breakers up to 1600 A

Project planning aids

VL400 (3VL4), 3- and 4-pole, up to 400 A

Terminals and phase barriers

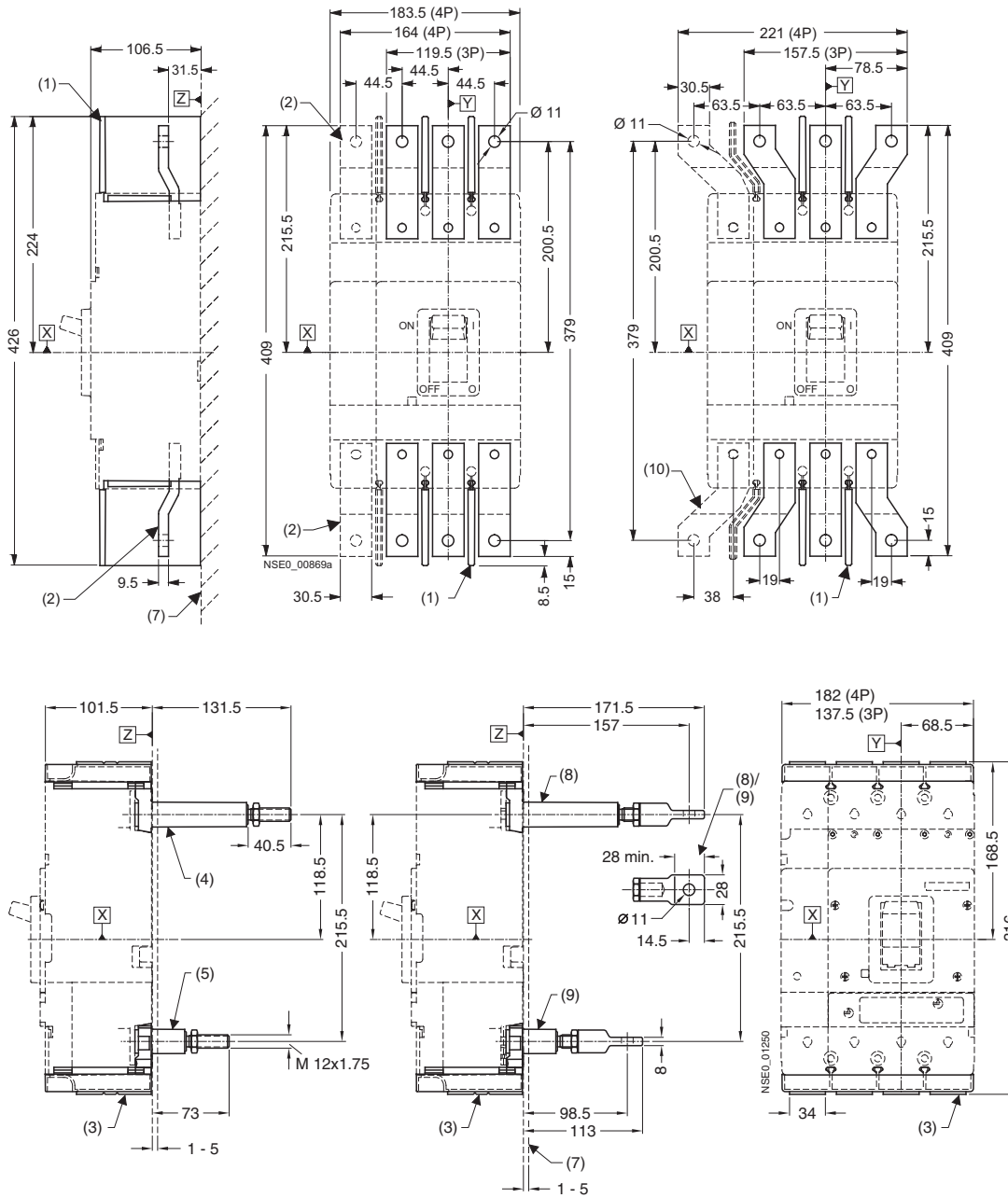

- (1) Phase barrier
- (2) Front connecting bars
- (3) Terminal covers (standard)
- (4) Rear terminal (long)
- (5) Rear terminal (short)
- (7) Installation level
- (8) Rear flat connector (long)
- (9) Rear flat connector (short)
- (10) Flared front busbar connecting bars

3VL Molded Case Circuit Breakers

3VL Molded Case Circuit Breakers up to 1600 A

Project planning aids

VL400 (3VL4), 3- and 4-pole, up to 400 A

Terminal covers

Circuit breaker installation instructions Front connecting bars

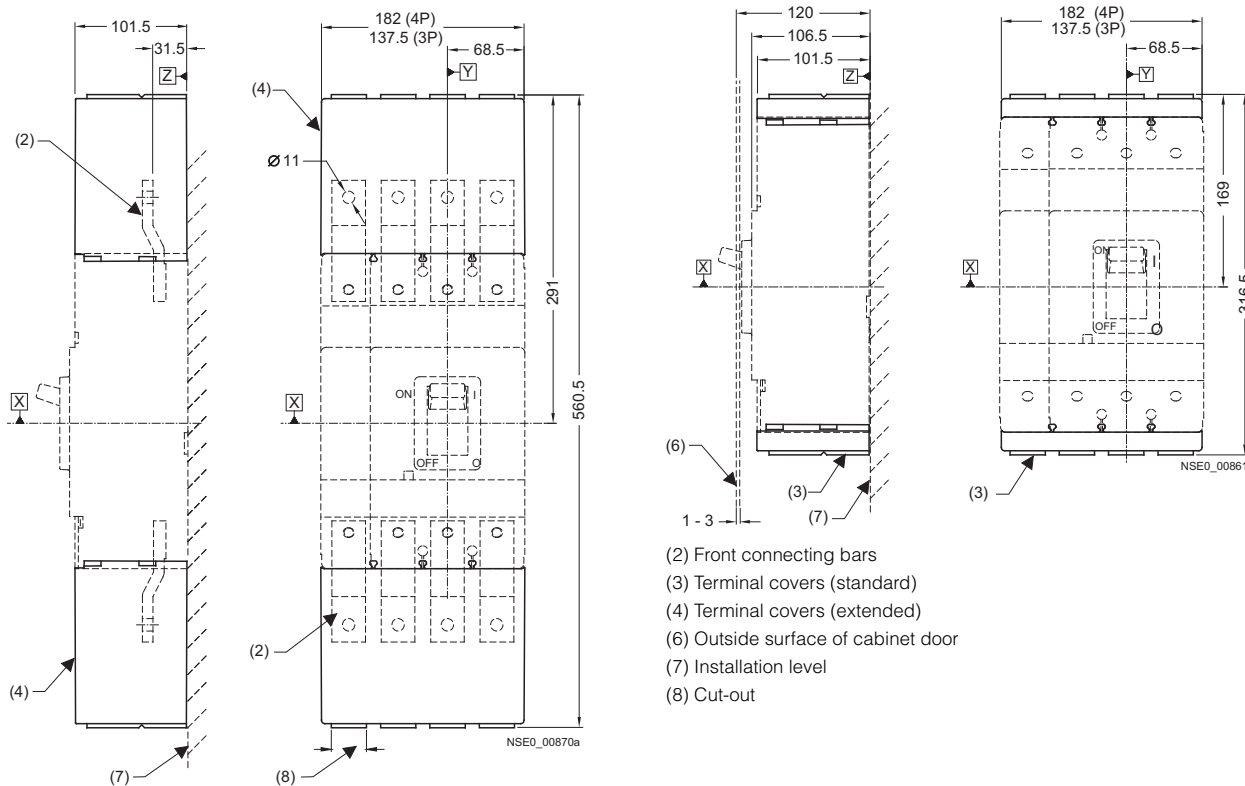

- (2) Front connecting bars
- (3) Terminal covers (standard)
- (4) Terminal covers (extended)
- (6) Outside surface of cabinet door
- (7) Installation level
- (8) Cut-out

Rear interlocking modules

Rear interlocking module for plug-in/withdrawable circuit breakers for front connection, without/with RCD module

For more detailed dimensional drawings
see "Mounting Instructions for Rear Interlocking Module".

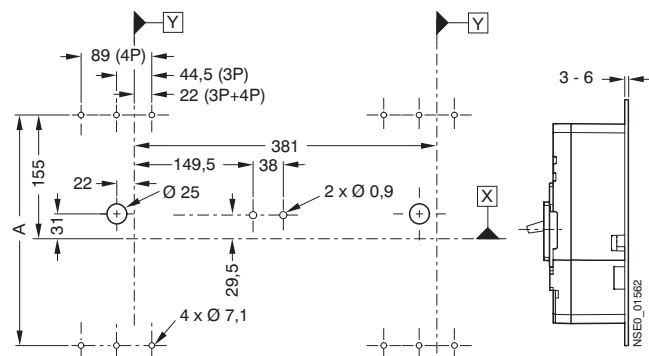

Rear interlocking module

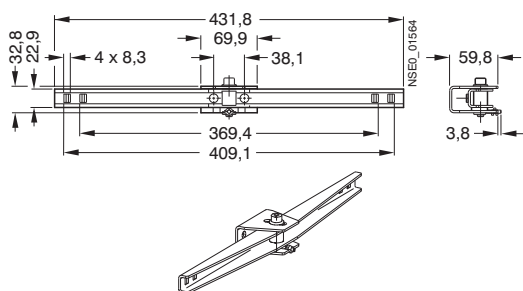

Type		A
Without RCD module	VL400 (3VL4)	289
With RCD module	VL400 (3VL4)	449

3VL Molded Case Circuit Breakers

3VL Molded Case Circuit Breakers up to 1600 A

Project planning aids

VL400 (3VL4), 3- and 4-pole, up to 400 A

Interlocks

Locking devices for toggle levers

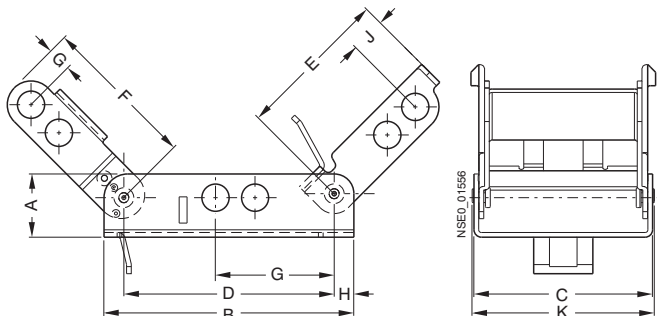

Type	a	b	c	d	e	f	g	h	i	k
3VL9 4	20.3	80.3	57.4	52.8	49.3	49.8	6.35	6.3	11.2	58.5
3VL9 6	21.6	79.8	71.1	62.0	50.4	46.5	12.9	8.9	8.6	72.2
3VL9 8	21.6	110.5	88.9	96.5	77.2	69.1	11.7	5.1	24.8	90.0

Accessories

Plug-in base for door-coupling rotary operating mechanism

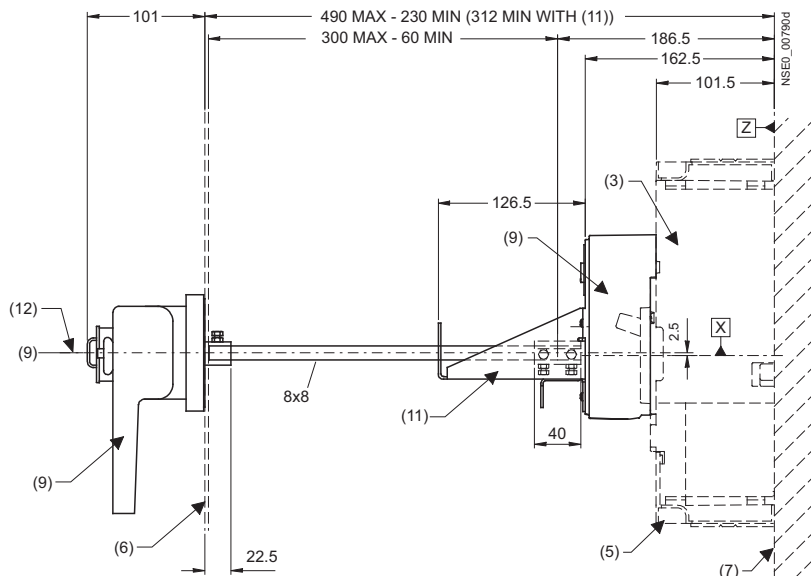

Masking frame for door cut-out for circuit breaker with toggle lever

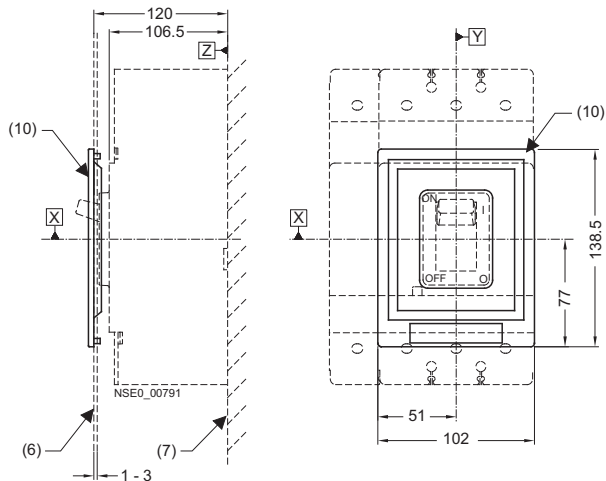

- (3) Circuit breaker
- (5) Terminal covers (standard)
- (6) Outside surface of cabinet door
- (7) Installation level
- (9) Door-coupling rotary operating mechanism
- (10) Masking frame for door cut-out (for circuit breaker with toggle lever)
- (11) Support bracket
- (12) Center line of drive shaft

3VL Molded Case Circuit Breakers

3VL Molded Case Circuit Breakers up to 1600 A

Project planning aids

VL400 (3VL4), 3- and 4-pole, up to 400 A

Door cut-outs

Door cut-out for toggle lever operating mechanism (without masking frame)

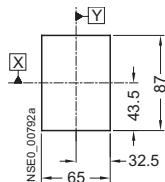

Door cut-out for front-operated rotary operating mechanism and motorized operating mechanism with stored-energy mechanism (without masking frame)

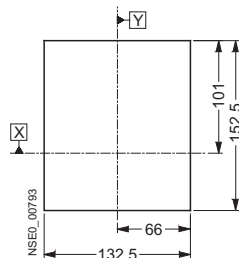

Door cut-out for door-coupling rotary operating mechanism

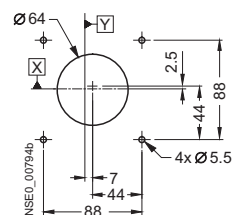

Door cut-out for toggle lever operating mechanism (with masking frame)

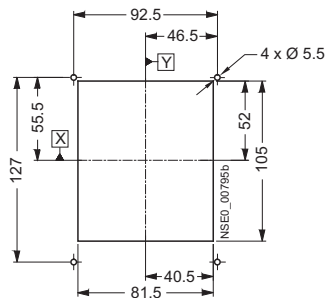

Door cut-out for front-operated rotary operating mechanism, motorized operating mechanism with stored-energy mechanism and extended escutcheon (with masking frame)

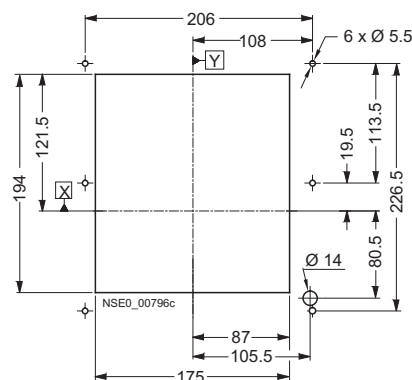

Hole pattern and cut-out for plug-in base with rear flat connection bars

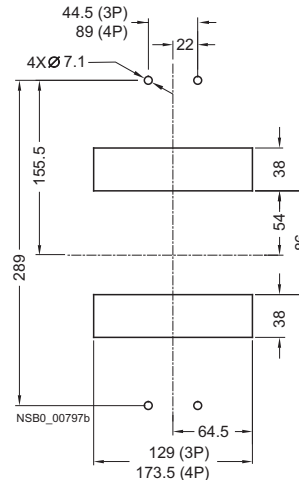

Hole pattern and cut-out for rear terminals

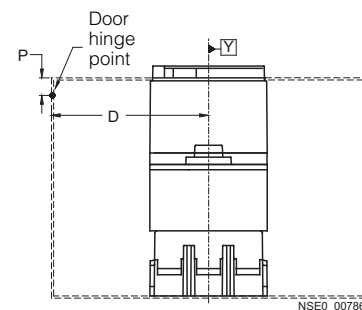
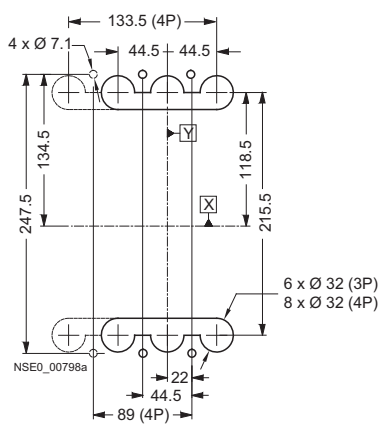

$D > A$ from table + $(P \times 5)$

Note:
A minimum distance between reference point Y and the door hinge is required for the door cut-outs.

Combination	A
Circuit breaker only	150
Circuit breaker + plug-in base + motorized operating mechanism with stored-energy mechanism	150
Circuit breaker + plug-in base + front-operated rotary operating mechanism	200
Circuit breaker + withdrawable version	200

3VL Molded Case Circuit Breakers

3VL Molded Case Circuit Breakers up to 1600 A

Project planning aids

VL400 (3VL4), 3- and 4-pole, up to 400 A

Plug-in bases and accessories

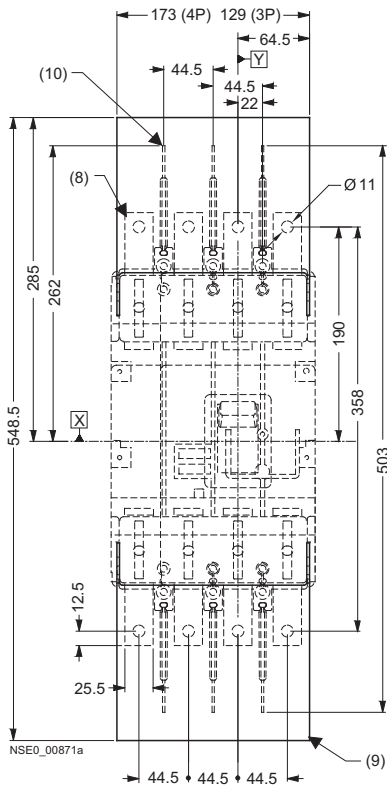
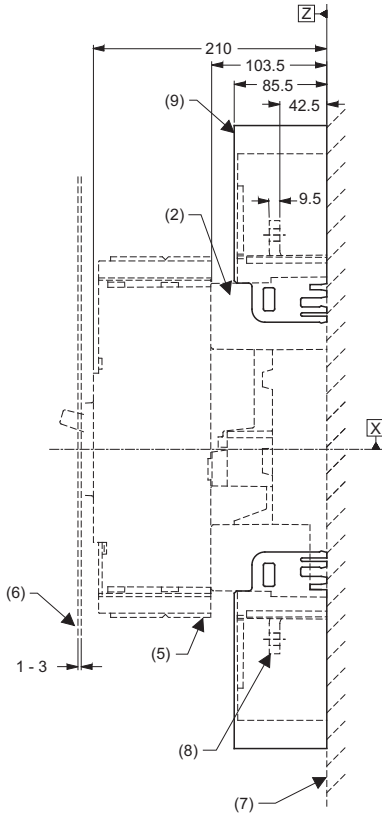

Hole pattern for plug-in base with front connecting bars

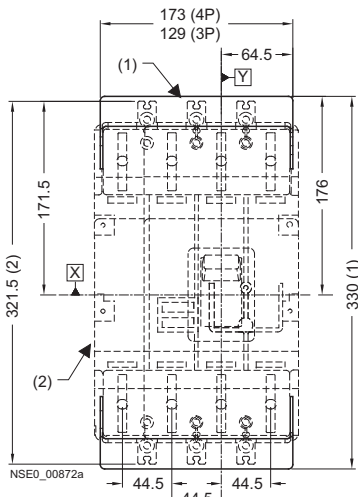
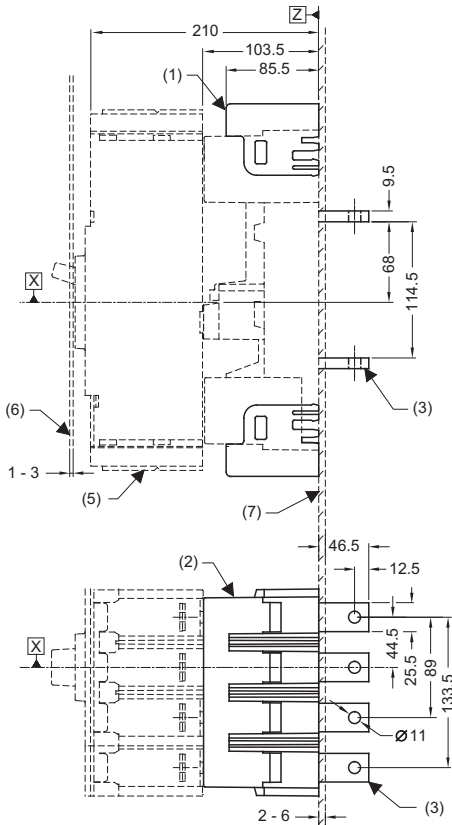
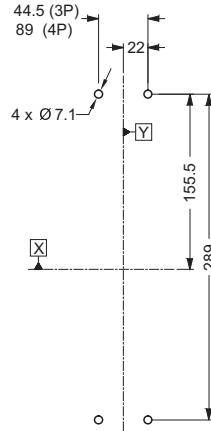

- (1) Plug-in base with rear terminal covers
- (2) Plug-in base
- (3) Plug-in base with rear flat connecting bars
- (5) Terminal covers (standard)
- (6) Outside surface of cabinet door
- (7) Installation level
- (8) Plug-in base with front connecting bars
- (9) Plug-in base with terminal covers on the front
- (10) Phase barrier

3VL Molded Case Circuit Breakers

3VL Molded Case Circuit Breakers up to 1600 A

Project planning aids

VL400 (3VL4), 3- and 4-pole, up to 400 A

Plug-in bases and accessories

Plug-in base for front-operated rotary operating mechanism (connected position)

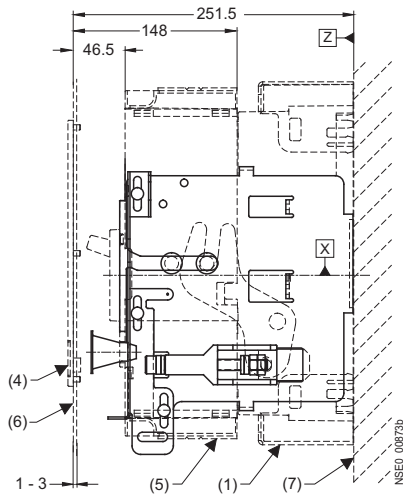

Plug-in base for front-operated rotary operating mechanism (disconnected position)

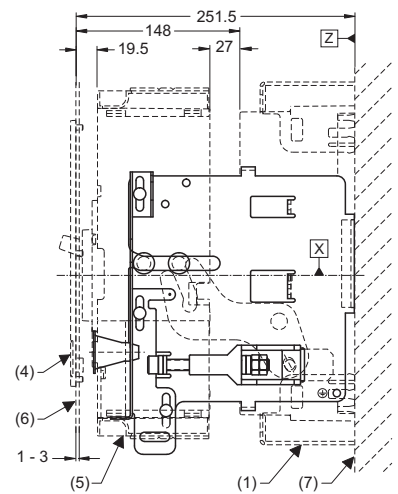

Plug-in base for motorized operating mechanism with stored-energy mechanism (connected position)

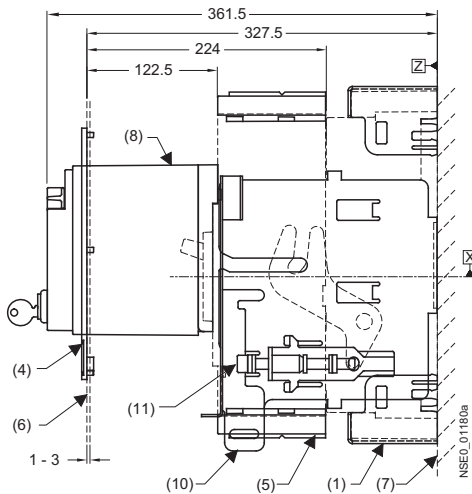

Plug-in base for motorized operating mechanism with stored-energy mechanism (disconnected position)

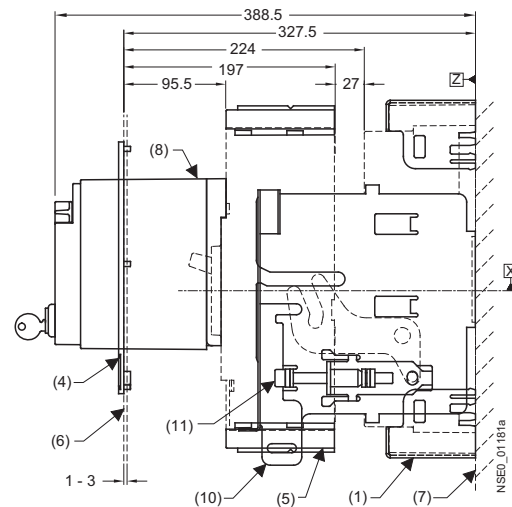

- (1) Plug-in base with terminal covers
- (4) Masking frame for door cut-out
(for circuit breaker with operating mechanism)
- (5) Terminal covers (standard)
- (6) Outside surface of cabinet door
- (7) Installation level
- (8) Motorized operating mechanism with stored-energy mechanism
- (9) Front-operated rotary operating mechanism
- (10) Locking device for racking mechanism
- (11) Racking mechanism

3VL Molded Case Circuit Breakers

3VL Molded Case Circuit Breakers up to 1600 A

Project planning aids

VL400 (3VL4), 3- and 4-pole, up to 400 A

Plug-in bases and accessories

Plug-in base for extended escutcheon (connected position)

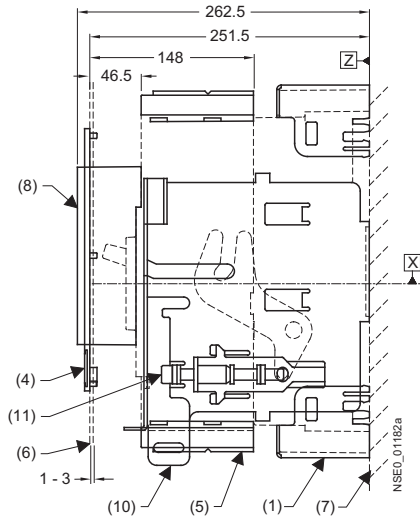

Plug-in base for extended escutcheon (disconnected position)

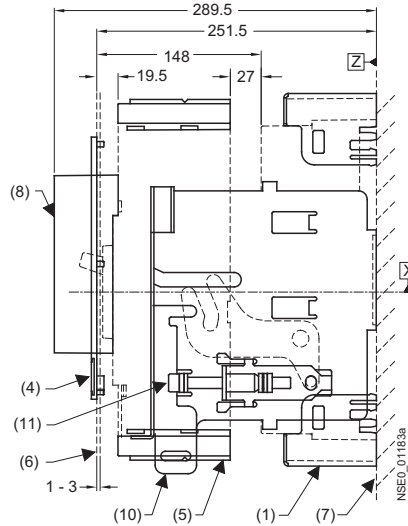

Extended escutcheon mounted on withdrawable version

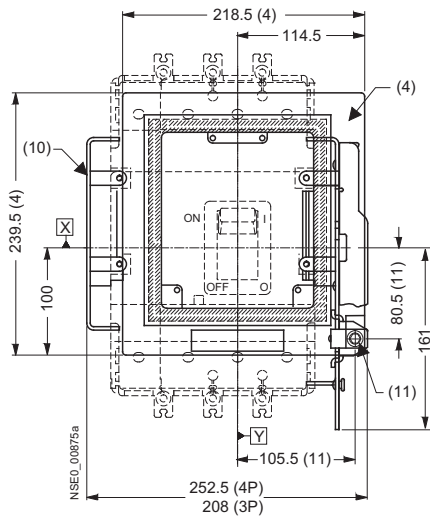

Locking device for
racking mechanism

- (1) Plug-in base with terminal covers
- (4) Masking frame for door cut-out
(for circuit breaker with operating mechanism)
- (5) Terminal covers (standard)
- (6) Outside surface of cabinet door
- (7) Installation level
- (8) Extended escutcheon
- (10) Locking device for racking mechanism
- (11) Racking mechanism

3VL Molded Case Circuit Breakers

3VL Molded Case Circuit Breakers up to 1600 A

Project planning aids

VL630 (3VL5), 3- and 4-pole, up to 630 A

Circuit breakers

SENTRON VL630 (3VL5) circuit breakers

Circuit breaker installation instructions

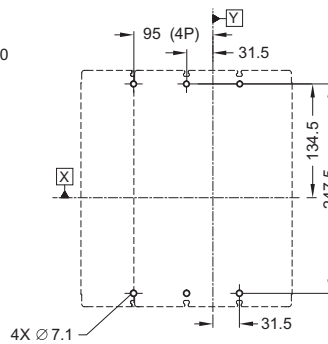
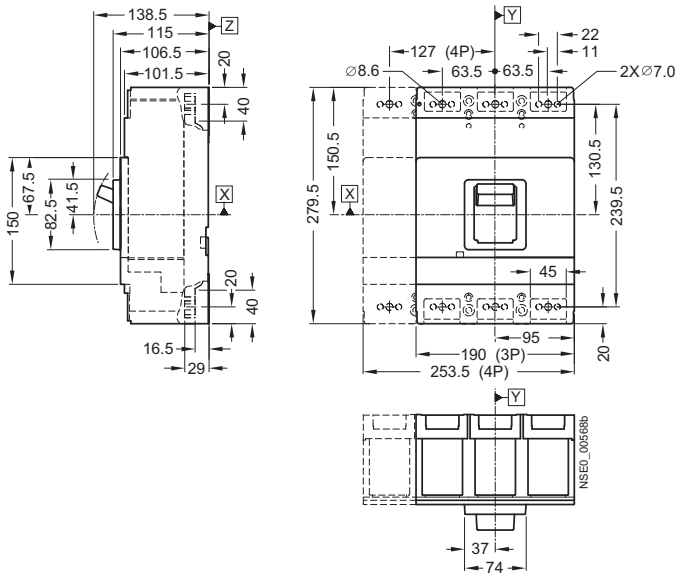

Operating mechanisms

Motorized operating mechanism with stored-energy mechanism

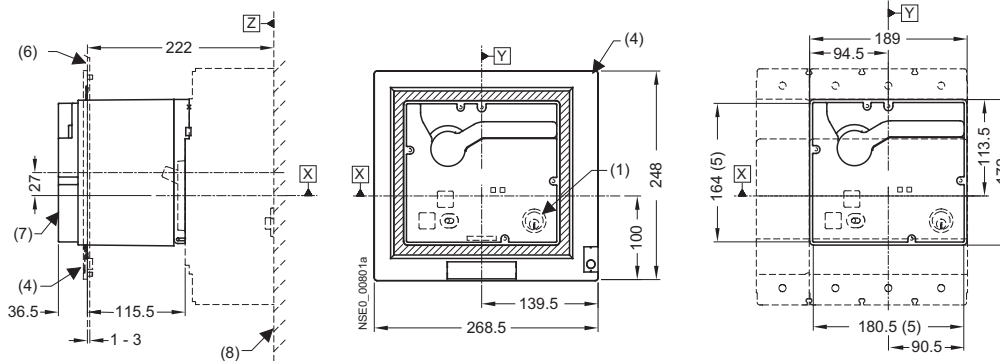

Front-operated rotary operating mechanism

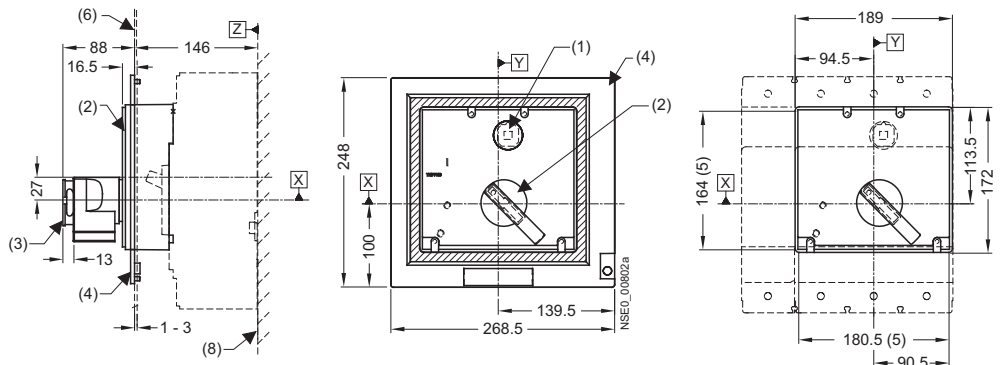

- (1) Safety lock
- (2) Front-operated rotary operating mechanism
- (3) Padlock
- (4) Masking frame for door cut-out (for circuit breaker with operating mechanism)
- (5) Step for cover
- (6) Outside surface of cabinet door
- (7) Motorized operating mechanism with stored-energy mechanism
- (8) Installation level

3VL Molded Case Circuit Breakers

3VL Molded Case Circuit Breakers up to 1600 A

Project planning aids

VL630 (3VL5), 3- and 4-pole, up to 630 A

Terminals and phase barriers

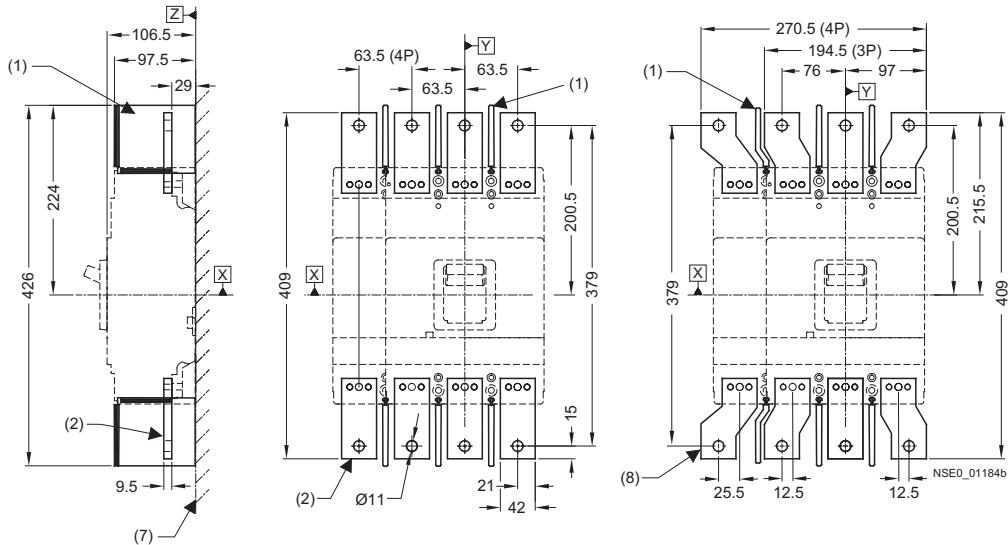

- (1) Phase barrier
- (2) Front connecting bars
- (3) Terminal covers (standard)
- (4) Rear terminal (horizontal connection)
- (5) Rear terminal (vertical connection)
- (7) Installation level
- (8) Flared front busbar connecting bars

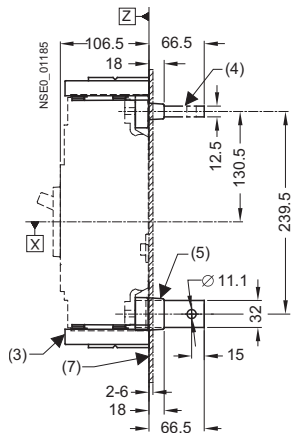

Terminal covers

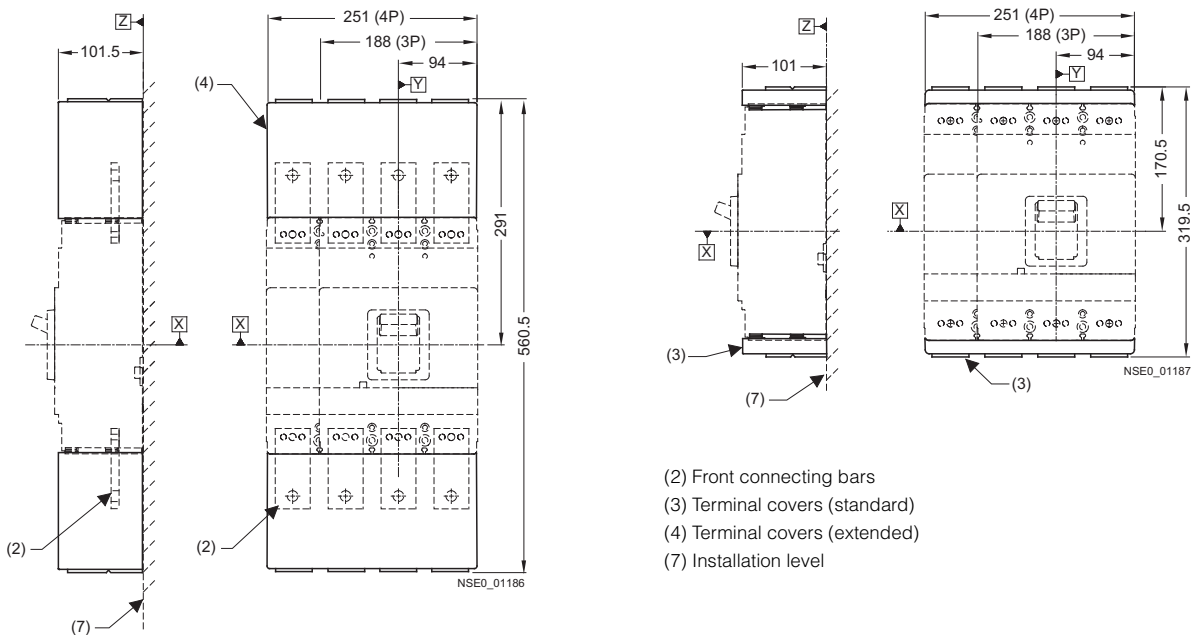

- (2) Front connecting bars
- (3) Terminal covers (standard)
- (4) Terminal covers (extended)
- (7) Installation level

3VL Molded Case Circuit Breakers

3VL Molded Case Circuit Breakers up to 1600 A

Project planning aids

VL630 (3VL5), 3- and 4-pole, up to 630 A

Interlocks

Locking devices for toggle levers

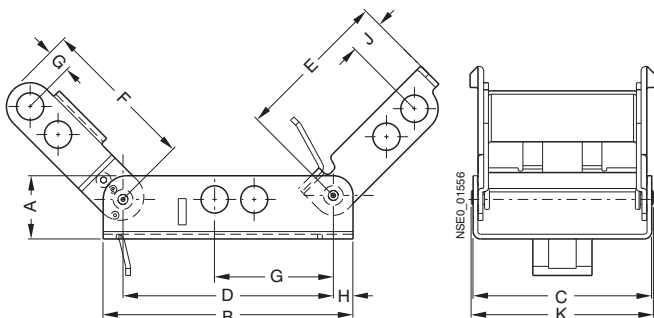

Type	a	b	c	d	e	f	g	h	i	k
3VL9 4	20.3	80.3	57.4	52.8	49.3	49.8	6.35	6.3	11.2	58.5
3VL9 6	21.6	79.8	71.1	62.0	50.4	46.5	12.9	8.9	8.6	72.2
3VL9 8	21.6	110.5	88.9	96.5	77.2	69.1	11.7	5.1	24.8	90.0

Rear interlocking modules

Rear interlocking module for plug-in/withdrawable circuit breakers for front connection

For more detailed dimensional drawings see mounting instructions for: "Rear Interlocking Module".

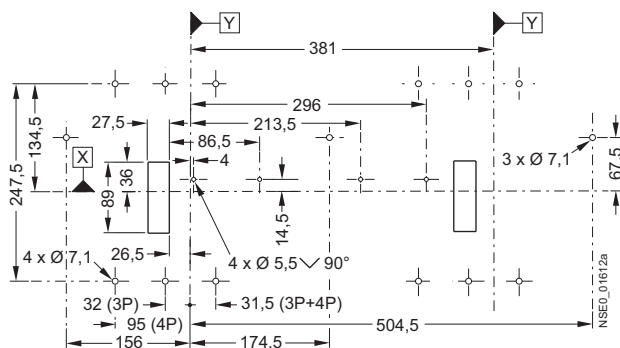

Rear interlocking module

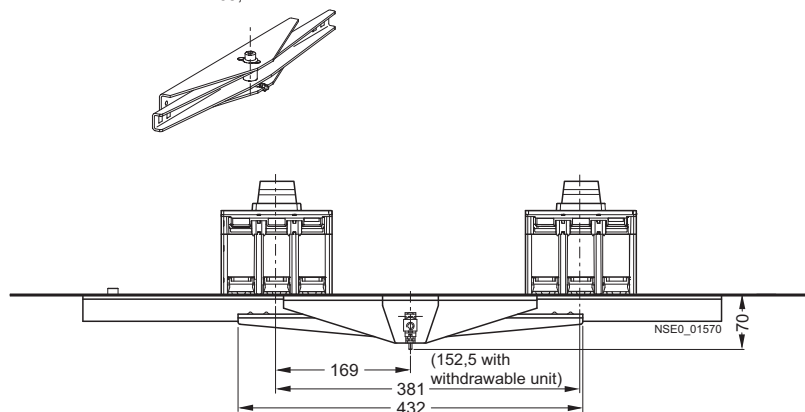
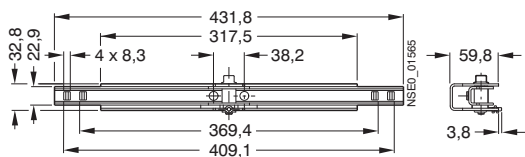

16

3VL Molded Case Circuit Breakers

3VL Molded Case Circuit Breakers up to 1600 A

Project planning aids

VL630 (3VL5), 3- and 4-pole, up to 630 A

Accessories

Door-coupling rotary operating mechanism

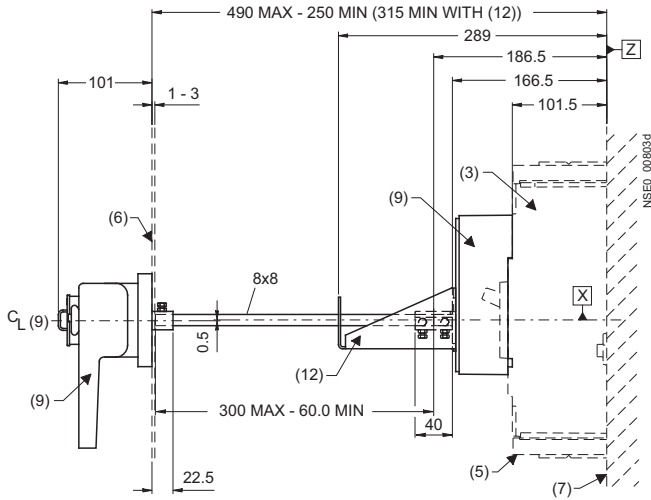

Masking frame for door cut-out for circuit breaker with toggle lever

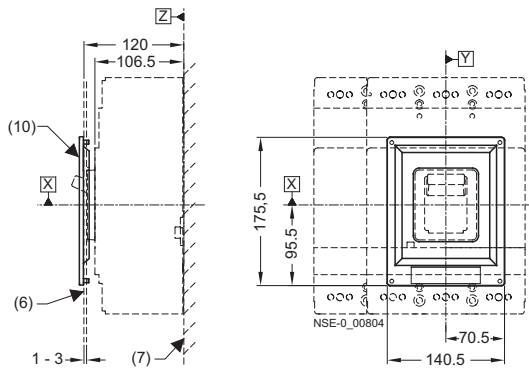

Masking frame for door cut-out for circuit breaker with operating mechanism

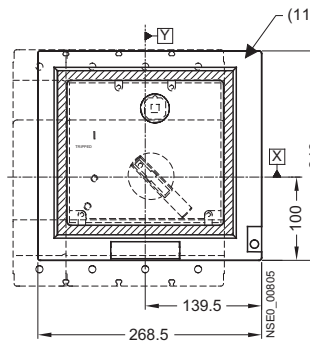

Toggle handle extension

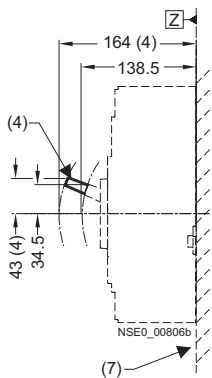

- (3) Circuit breaker
- (4) Toggle handle extension
- (5) Terminal covers (standard)
- (6) Outside surface of cabinet door
- (7) Installation level
- (9) Door-coupling rotary operating mechanism
- (10) Masking frame for door cut-out (for circuit breaker with toggle lever)
- (11) Masking frame for door cut-out (for circuit breaker with operating mechanism)
- (12) Support bracket

3VL Molded Case Circuit Breakers

3VL Molded Case Circuit Breakers up to 1600 A

Project planning aids

VL630 (3VL5), 3- and 4-pole, up to 630 A

Door cut-outs

Door cut-out for door-coupling rotary operating mechanism

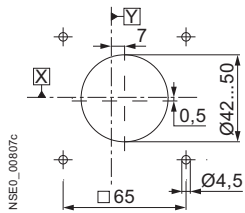

Door cut-out for front-operated rotary operating mechanism, motorized operating mechanism with stored-energy mechanism and extended escutcheon (without masking frame)

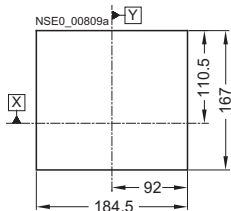

Door cut-out for front-operated rotary operating mechanism, motorized operating mechanism with stored-energy mechanism and extended escutcheon (with masking frame)

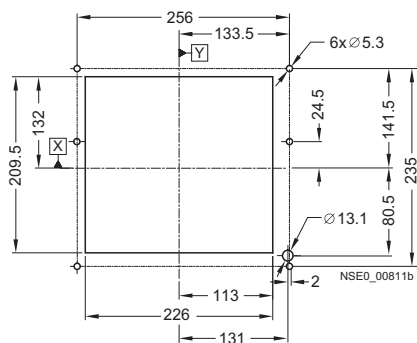

Door cut-out for toggle lever operating mechanism (without masking frame)

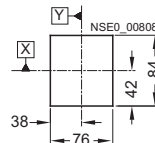

Door cut-out for toggle lever operating mechanism (with masking frame)

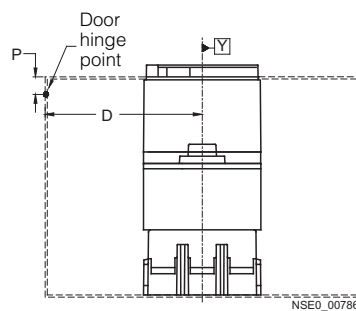
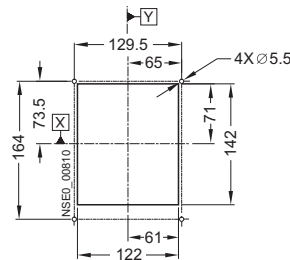

Note:
A minimum distance between reference point Y and the door hinge is required for the door cut-outs.

D > A from table + (P x 5)

Combination	A
Circuit breaker only	150
Circuit breaker + plug-in base + motorized operating mechanism with stored-energy mechanism	150
Circuit breaker + plug-in base + front-operated rotary operating mechanism	200
Circuit breaker + withdrawable version	200

Hole pattern and cut-out for plug-in base (with rear flat bar connection)

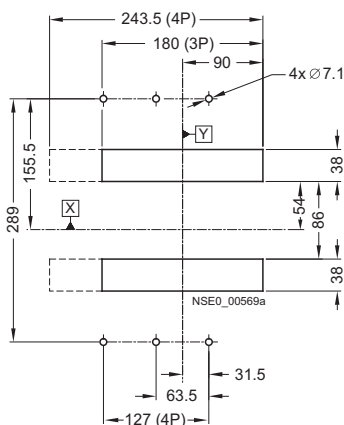

Hole pattern and cut-out for circuit breaker (with rear flat bar connection)

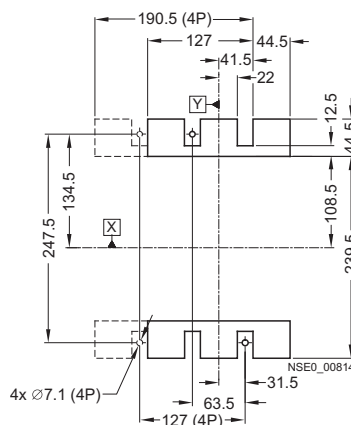

16

3VL Molded Case Circuit Breakers

3VL Molded Case Circuit Breakers up to 1600 A

Project planning aids

VL630 (3VL5), 3- and 4-pole, up to 630 A

Plug-in bases and accessories

Plug-in base with terminal covers on the front

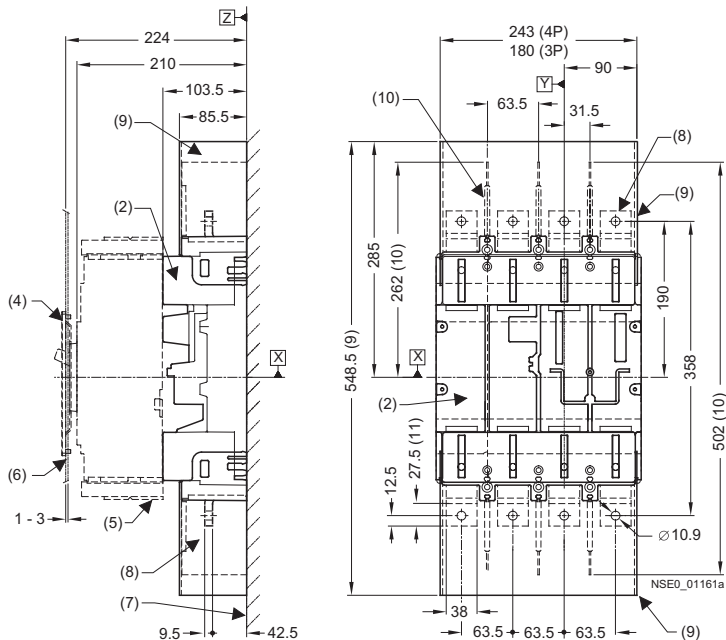

Hole pattern for plug-in base, front connecting bars

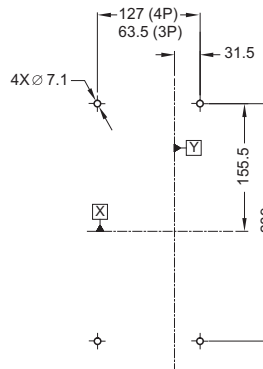

Plug-in base, with terminal covers, rear flat connecting bars

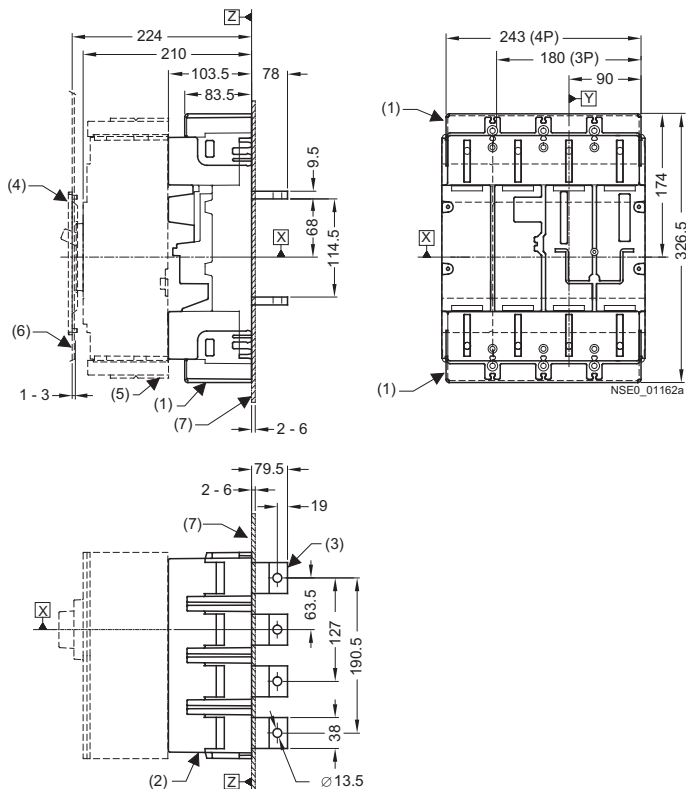

Plug-in base

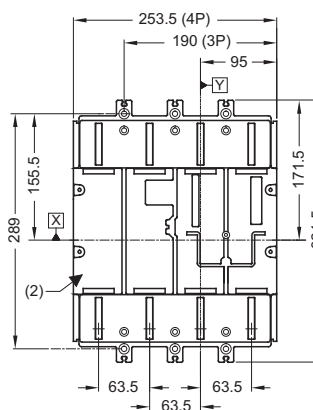

- (1) Plug-in base with rear terminal covers
- (2) Plug-in base
- (3) Plug-in base with rear flat connecting bars
- (4) Masking frame for door cut-out (for circuit breaker with toggle lever)
- (5) Terminal covers (standard)
- (6) Outside surface of cabinet door
- (7) Installation level
- (8) Plug-in base with front connecting bars
- (9) Plug-in base with terminal covers on the front
- (10) Phase barrier
- (11) Terminal face

3VL Molded Case Circuit Breakers

3VL Molded Case Circuit Breakers up to 1600 A

Project planning aids

VL630 (3VL5), 3- and 4-pole, up to 630 A

Withdrawable version and accessories

SENTRON VL630 (3VL5) circuit breakers with rotary operating mechanism, withdrawable version (connected position)

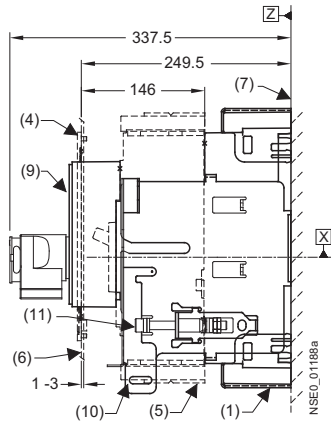

SENTRON VL630 (3VL5) circuit breakers with rotary operating mechanism, withdrawable version (disconnected position)

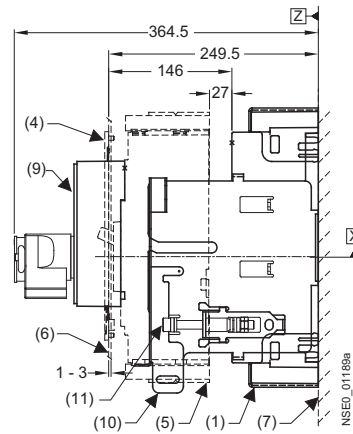

SENTRON VL630 (3VL5) circuit breakers with motorized operating mechanism with stored-energy mechanism, withdrawable version (connected position)

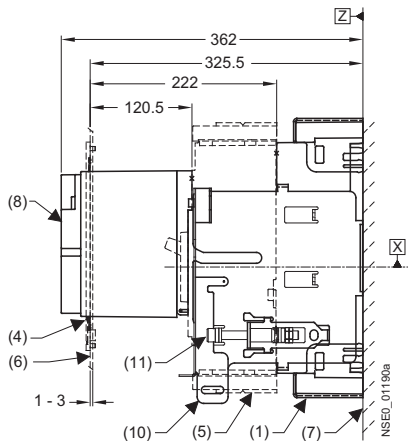

SENTRON VL630 (3VL5) circuit breakers with motorized operating mechanism with stored-energy mechanism, withdrawable version (disconnected position)

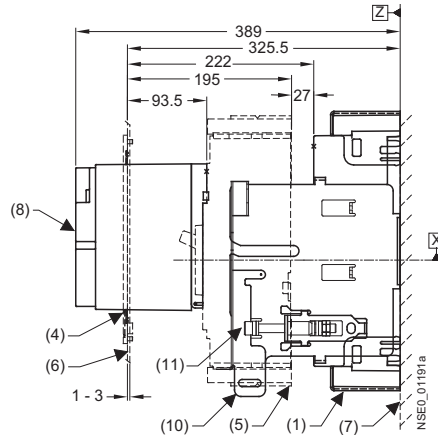

- (1) Plug-in base with terminal covers
- (4) Masking frame for door cut-out
(for circuit breaker with operating mechanism)
- (5) Terminal covers (standard)
- (6) Outside surface of cabinet door
- (7) Installation level
- (8) Motorized operating mechanism with stored-energy mechanism
- (9) Front-operated rotary operating mechanism
- (10) Locking device for racking mechanism
- (11) Racking mechanism

3VL Molded Case Circuit Breakers

3VL Molded Case Circuit Breakers up to 1600 A

Project planning aids

VL630 (3VL5), 3- and 4-pole, up to 630 A

Withdrawable version and accessories

SENTRON VL630 (3VL5) circuit breakers with extended escutcheon, withdrawable version (connected position)

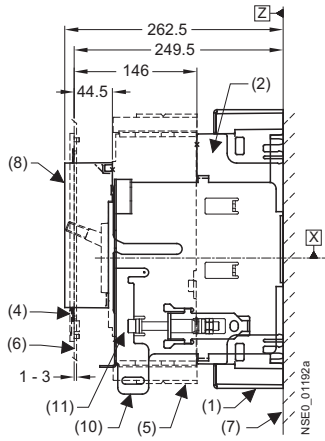

SENTRON VL630 (3VL5) circuit breakers with extended escutcheon, withdrawable version (disconnected position)

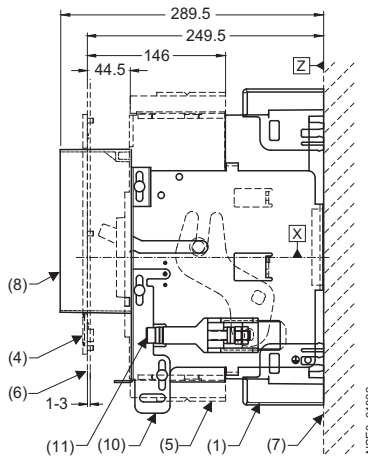

SENTRON VL630 (3VL5) circuit breakers with extended escutcheon, withdrawable version

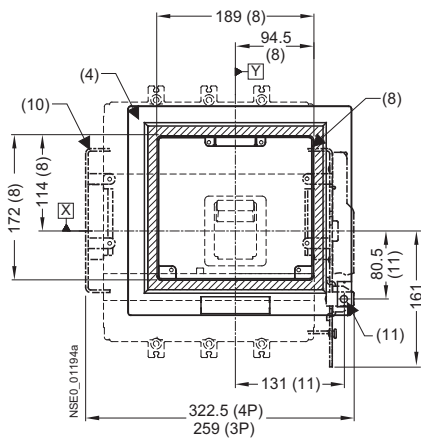

- (1) Plug-in base with terminal covers
- (2) Plug-in base
- (4) Masking frame for door cut-out
(for circuit breaker with operating mechanism)
- (5) Terminal covers (standard)
- (6) Outside surface of cabinet door
- (7) Installation level
- (8) Extended escutcheon
- (10) Locking device for racking mechanism
- (11) Racking mechanism

3VL Molded Case Circuit Breakers

3VL Molded Case Circuit Breakers up to 1600 A

Project planning aids

VL800 (3VL6), 3- and 4-pole, up to 800 A

Circuit breakers

SENTRON VL800 (3VL6) circuit breaker

Circuit breaker installation instructions

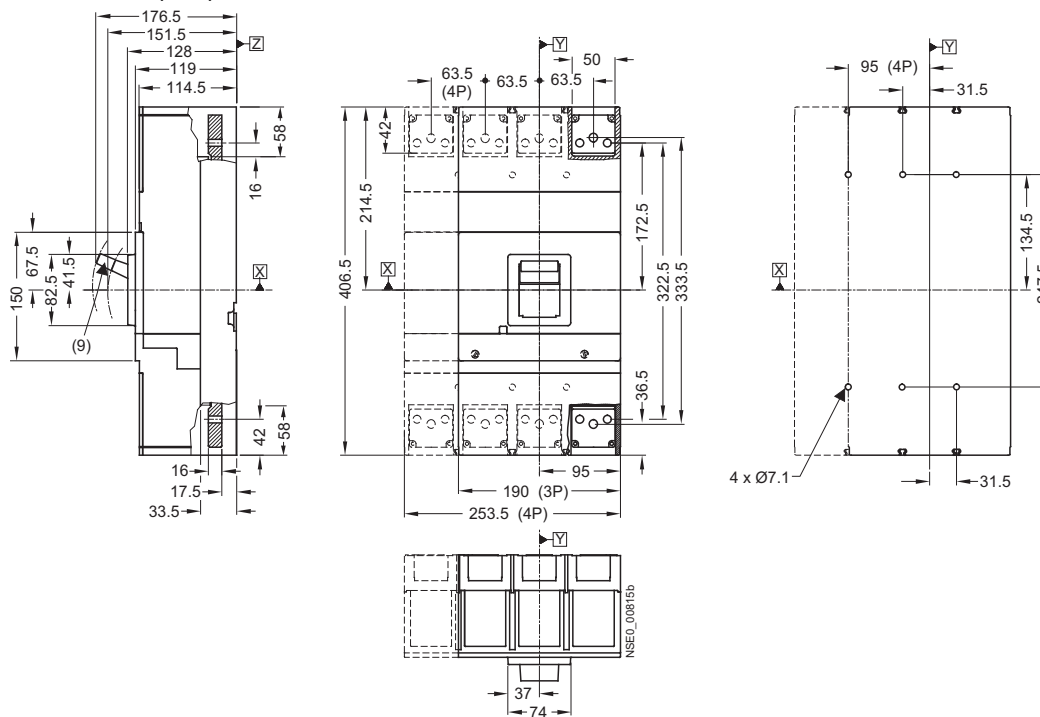

Operating mechanisms

Motorized operating mechanism with stored-energy mechanism

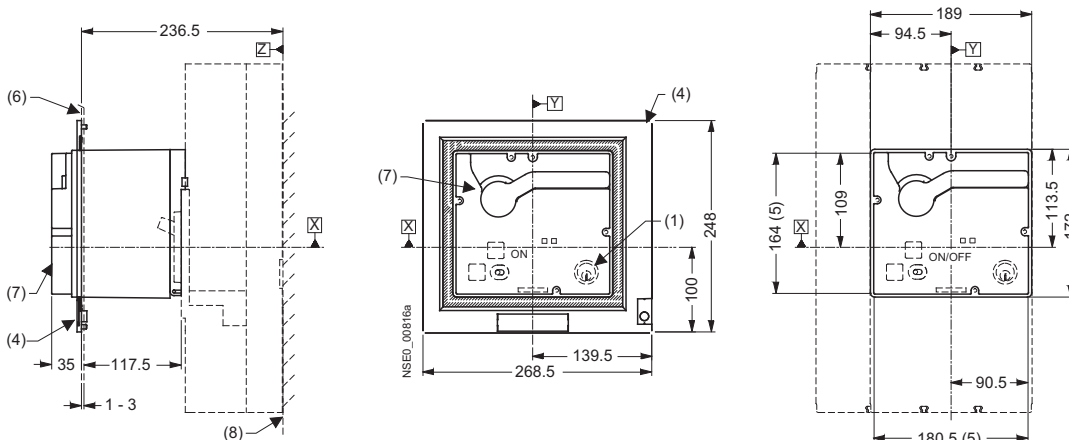

Front-operated rotary operating mechanism

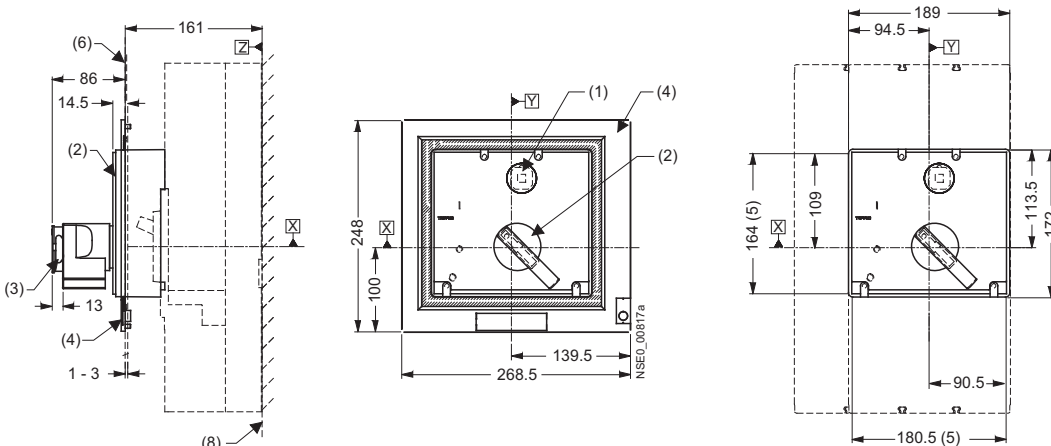

- (1) Safety lock
- (2) Front-operated rotary operating mechanism
- (3) Padlock
- (4) Masking frame for door cut-out (for circuit breaker with operating mechanism)
- (5) Step for cover
- (6) Outside surface of cabinet door
- (7) Motorized operating mechanism with stored-energy mechanism
- (8) Installation level
- (9) Toggle lever extension

3VL Molded Case Circuit Breakers

3VL Molded Case Circuit Breakers up to 1600 A

Project planning aids

VL800 (3VL6), 3- and 4-pole, up to 800 A

Withdrawable versions

Withdrawable version with front-operated rotary operating mechanism
Insert position

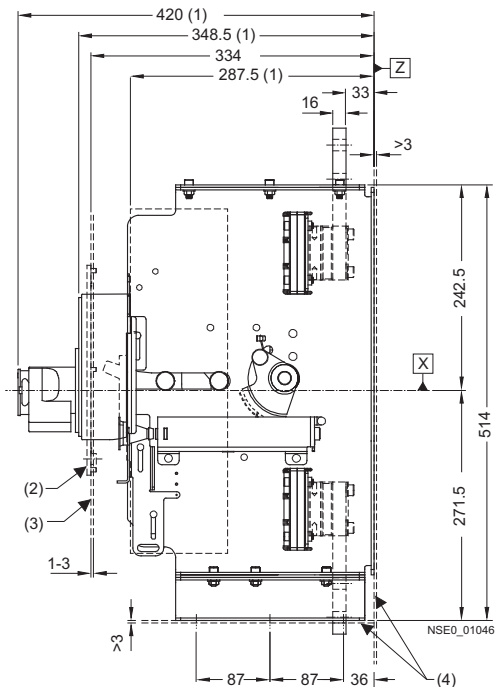

Withdrawable version with front-operated rotary operating mechanism
Withdraw position

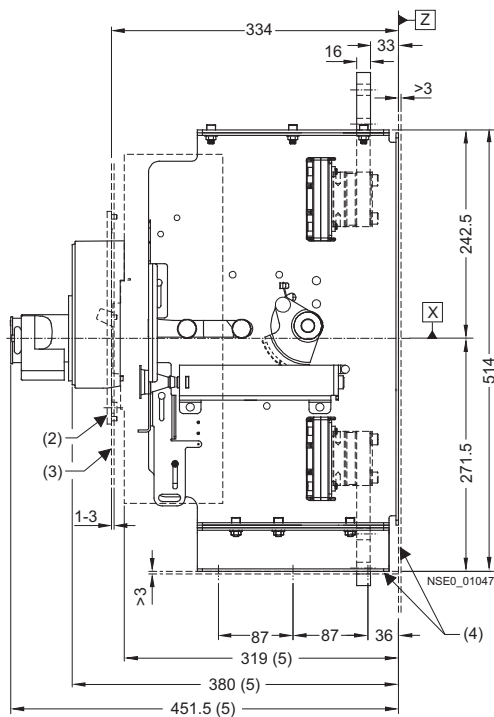

Withdrawable version with motorized operating mechanism with stored-energy mechanism
Insert position

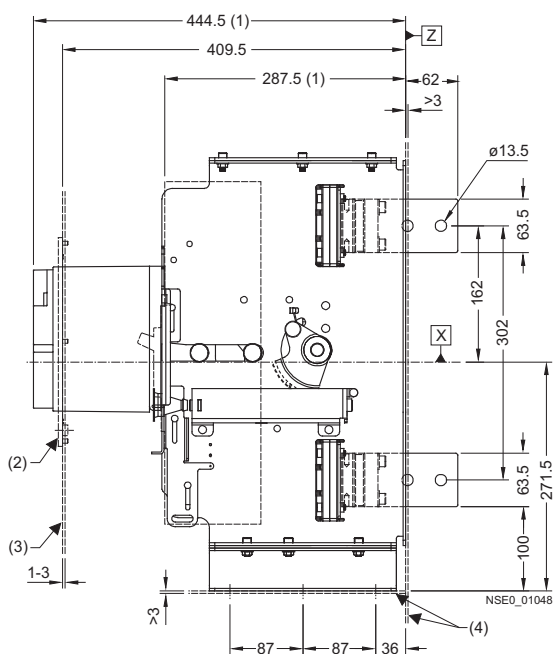

Withdrawable version with motorized operating mechanism with stored-energy mechanism
Withdraw position

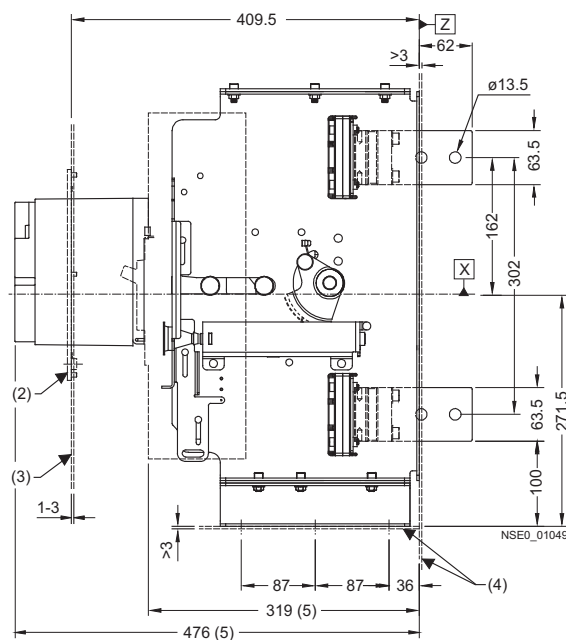

- (1) Connected position
- (2) Masking frame for door cut-out
- (3) Outside surface of cabinet door
- (4) Installation level
- (5) Disconnected position

3VL Molded Case Circuit Breakers

3VL Molded Case Circuit Breakers up to 1600 A

Project planning aids

VL 800 (3VL6), 3- and 4-pole, up to 800 A

Withdrawable version with extended escutcheon
(without masking frame)

Insert position

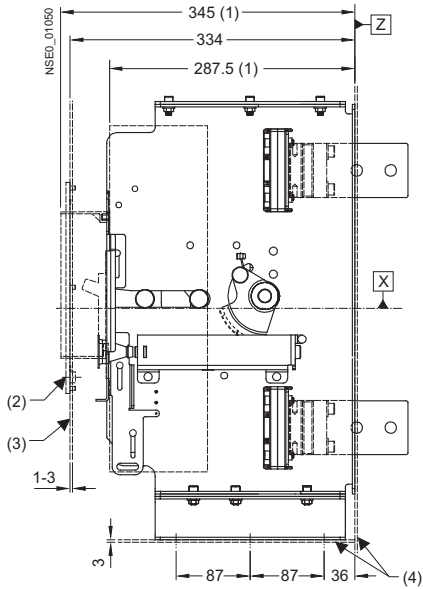

Withdrawable version with extended escutcheon
(without masking frame)

Withdraw position

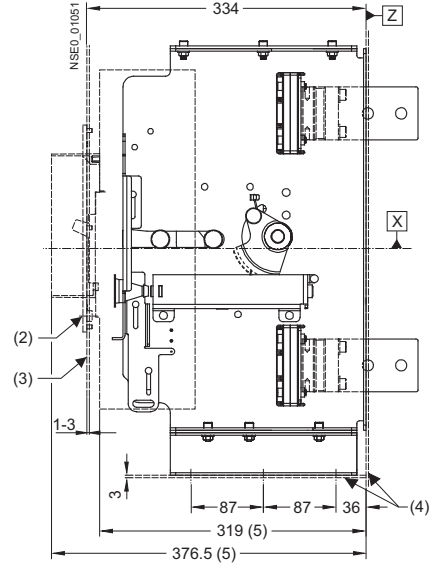

- (1) Connected position
- (2) Masking frame for door cut-out
- (3) Outside surface of cabinet door
- (4) Installation level
- (5) Disconnected position

3VL Molded Case Circuit Breakers

3VL Molded Case Circuit Breakers up to 1600 A

Project planning aids

VL800 (3VL6), 3- and 4-pole, up to 800 A

Withdrawable versions

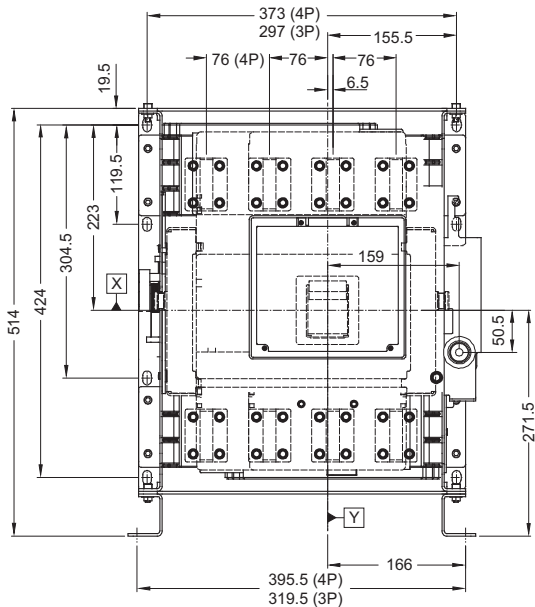

Hole pattern and cut-out for withdrawable versions with rear flat bar connection

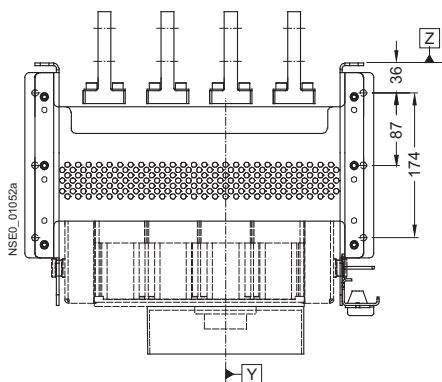
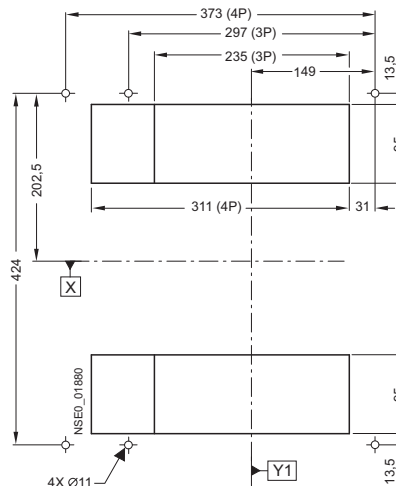

Terminals and phase barriers

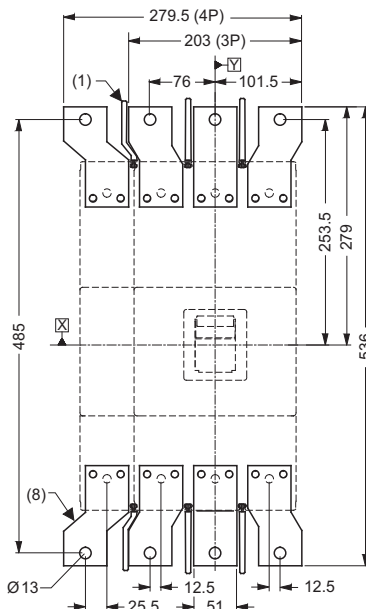
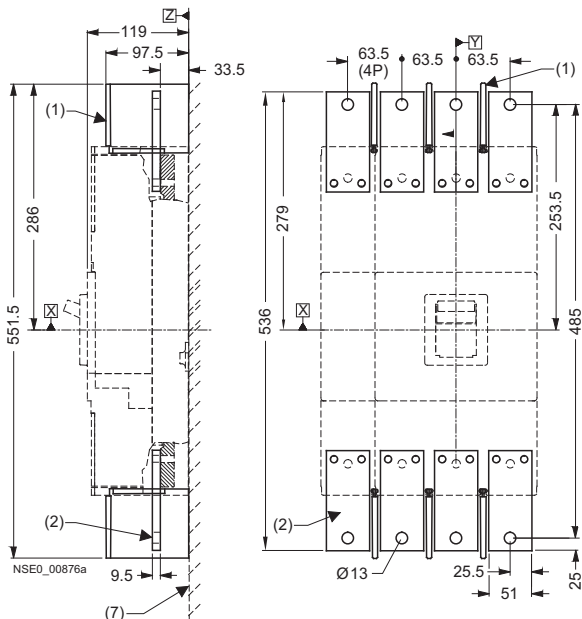

- (1) Phase barrier
- (2) Front connecting bars
- (7) Installation level
- (8) Flared front busbar connecting bars

3VL Molded Case Circuit Breakers

3VL Molded Case Circuit Breakers up to 1600 A

Project planning aids

VL800 (3VL6), 3- and 4-pole, up to 800 A

Terminal covers

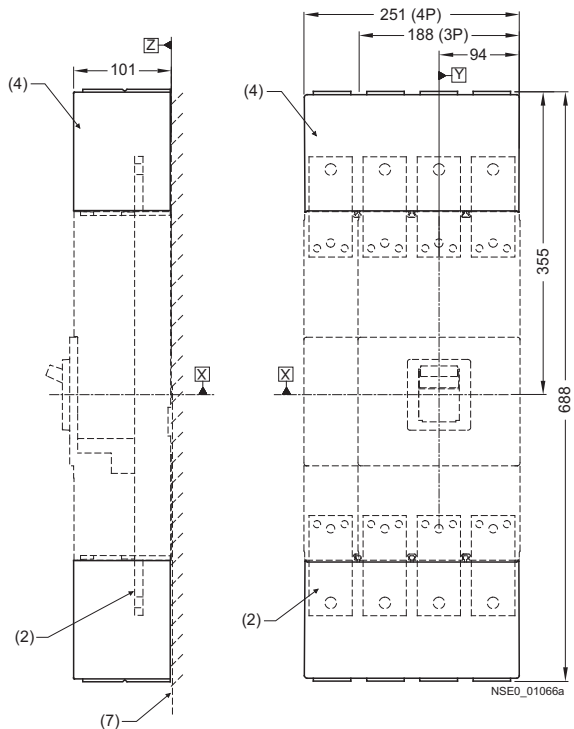

- (2) Front connecting bars
- (3) Terminal covers (standard)
- (4) Terminal covers (extended)
- (7) Installation level
- (8) Rear terminal (mounted horizontally)
- (9) Rear terminal (mounted vertically)

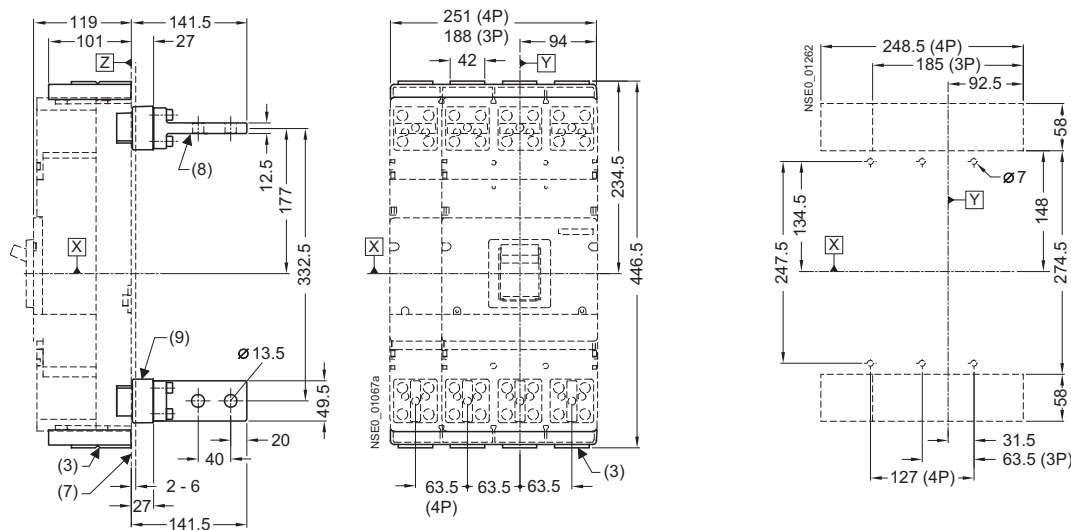

Interlocks

Locking devices for toggle levers

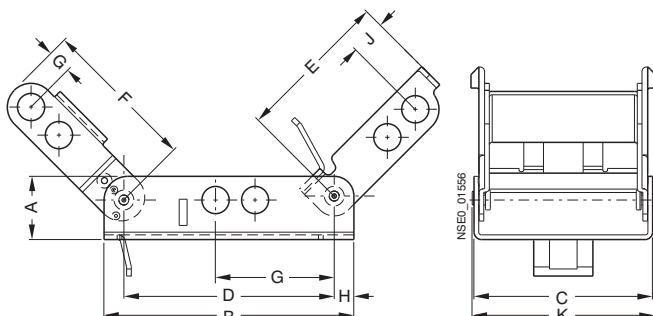

Type	a	b	c	d	e	f	g	h	i	k
3VL9 4	20.3	80.3	57.4	52.8	49.3	49.8	6.35	6.3	11.2	58.5
3VL9 6	21.6	79.8	71.1	62.0	50.4	46.5	12.9	8.9	8.6	72.2
3VL9 8	21.6	110.5	88.9	96.5	77.2	69.1	11.7	5.1	24.8	90.0

16

3VL Molded Case Circuit Breakers

3VL Molded Case Circuit Breakers up to 1600 A

Project planning aids

VL800 (3VL6), 3- and 4-pole, up to 800 A

Rear interlocking modules

Rear interlocking module 3-pole circuit breaker

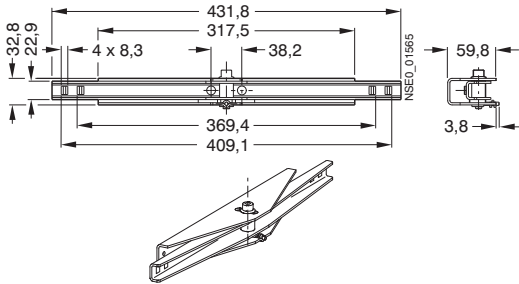

For more detailed dimensional drawings see "Mounting Instructions for Rear Interlocking Module".

Rear interlocking module 4-pole circuit breaker

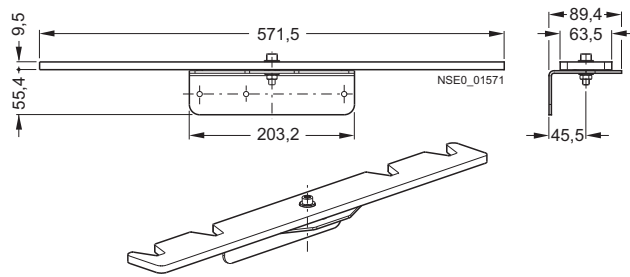

Rear interlocking module

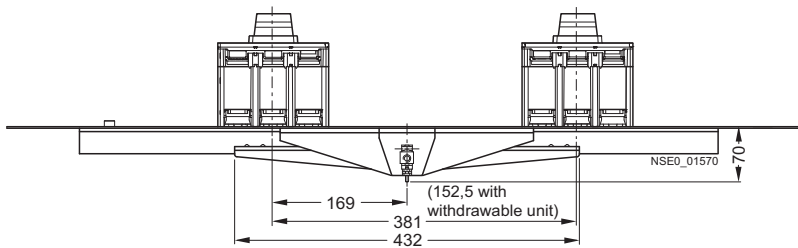

3VL Molded Case Circuit Breakers

3VL Molded Case Circuit Breakers up to 1600 A

Project planning aids

VL800 (3VL6), 3- and 4-pole, up to 800 A

Accessories

Door-coupling rotary operating mechanism

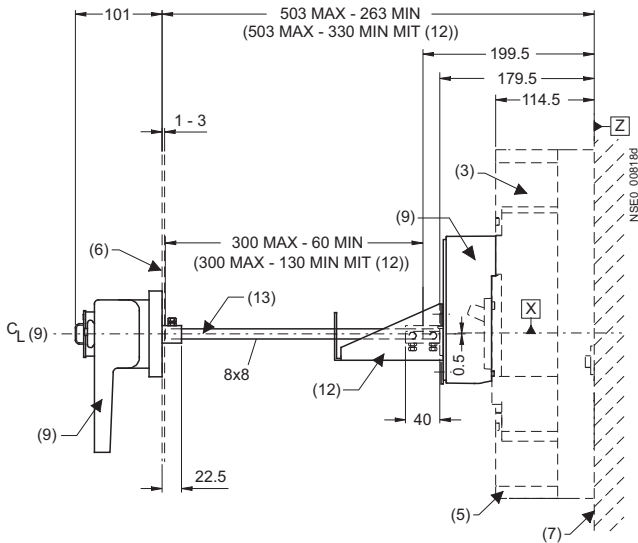

Masking frame for door cut-out for circuit breaker with toggle lever

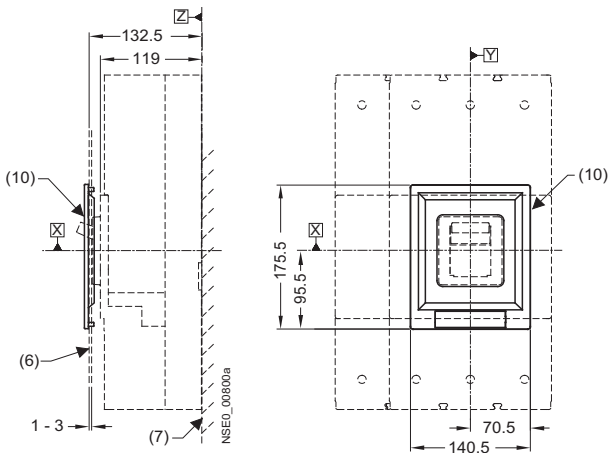

Masking frame for door cut-out for circuit breaker with operating mechanism

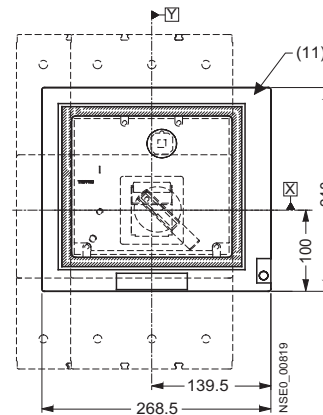

Toggle handle extension

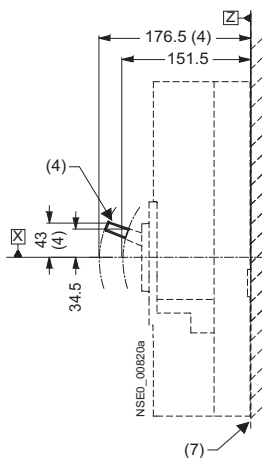

- (3) Circuit breaker
- (4) Toggle handle extension
- (5) Terminal covers (standard)
- (6) Outside surface of cabinet door
- (7) Installation level
- (9) Door-coupling rotary operating mechanism
- (10) Masking frame for door cut-out (for circuit breaker with toggle lever)
- (11) Masking frame for door cut-out (for circuit breaker with operating mechanism)
- (12) Support bracket
- (13) Center line of drive shaft

16

VL800 (3VL6), 3- and 4-pole, up to 800 A

Door cut-outs

Door cut-out

Door-coupling rotary operating mechanism

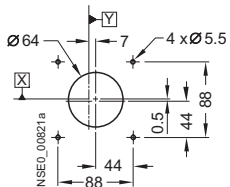

Door cut-out for toggle lever (without masking frame)

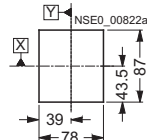

Door cut-out for front-operated rotary operating mechanism, motorized operating mechanism with stored-energy mechanism and extended escutcheon (without masking frame)

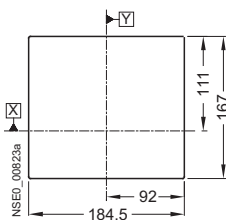

Door cut-out for toggle lever (with masking frame)

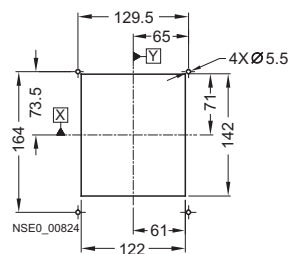

Door cut-out for front-operated rotary operating mechanism, motorized operating mechanism with stored-energy mechanism and extended escutcheon (with masking frame)

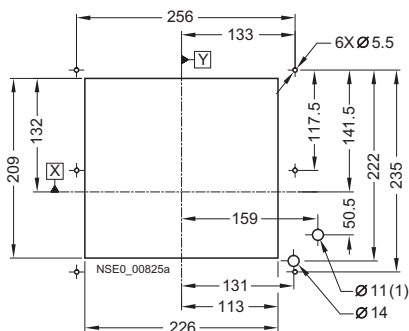

(1) Withdrawable version only

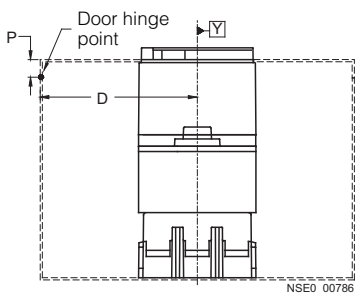

Note:
A minimum distance between reference point Y and the door hinge is required for the door cut-outs.

$D > A$ from table + $(P \times 5)$

Combination	A
Circuit breaker only	150
Circuit breaker + plug-in base + motorized operating mechanism with stored-energy mechanism	150
Circuit breaker + plug-in base + front-operated rotary operating mechanism	200
Circuit breaker + withdrawable version	200

3VL Molded Case Circuit Breakers

3VL Molded Case Circuit Breakers up to 1600 A

Project planning aids

VL1250 (3VL7) and VL1600 (3VL8), 3- and 4-pole, up to 1600 A

Circuit breakers

SENTRON VL1250 (3VL7) circuit breaker

Circuit breaker installation instructions

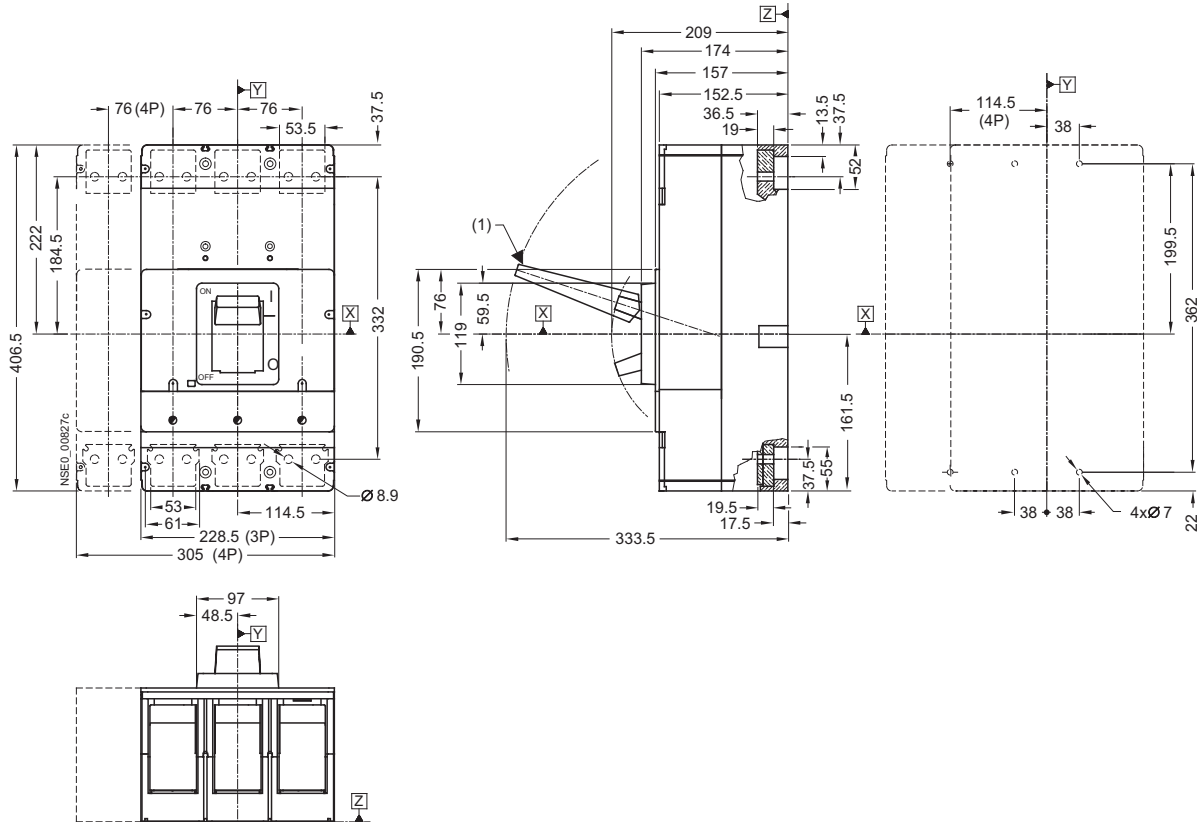

SENTRON VL1600 (3VL8) circuit breaker

Circuit breaker installation instructions

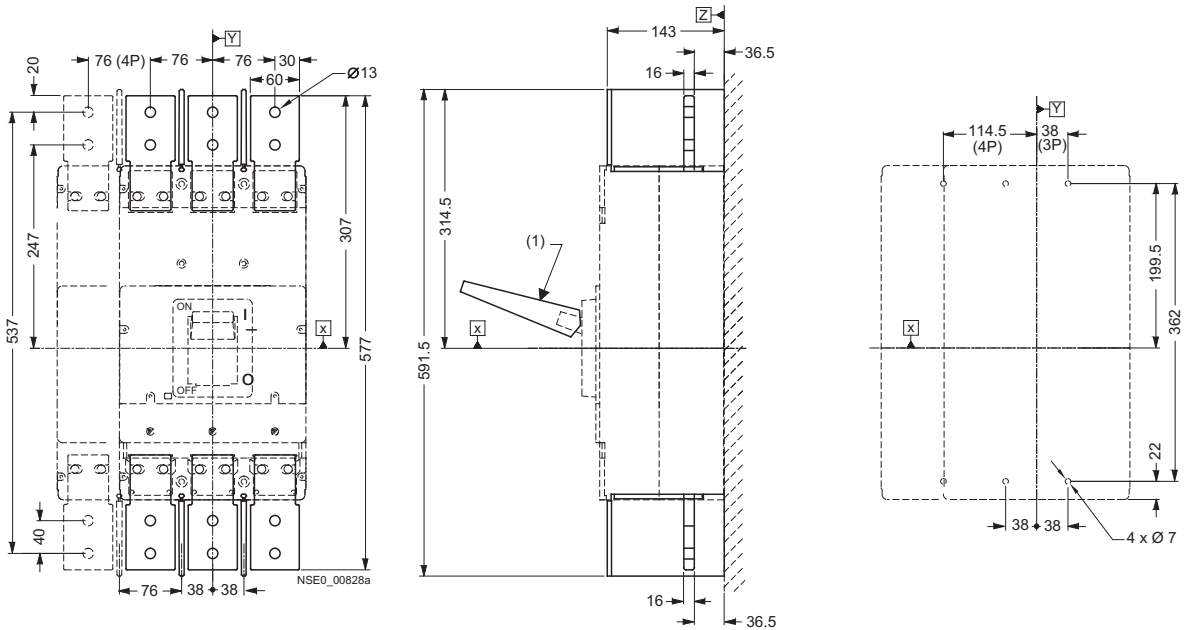

(1) Toggle handle extension

3VL Molded Case Circuit Breakers

3VL Molded Case Circuit Breakers up to 1600 A

Project planning aids

VL1250 (3VL7) and VL1600 (3VL8), 3- and 4-pole, up to 1600 A

Operating mechanisms

Motorized operating mechanism

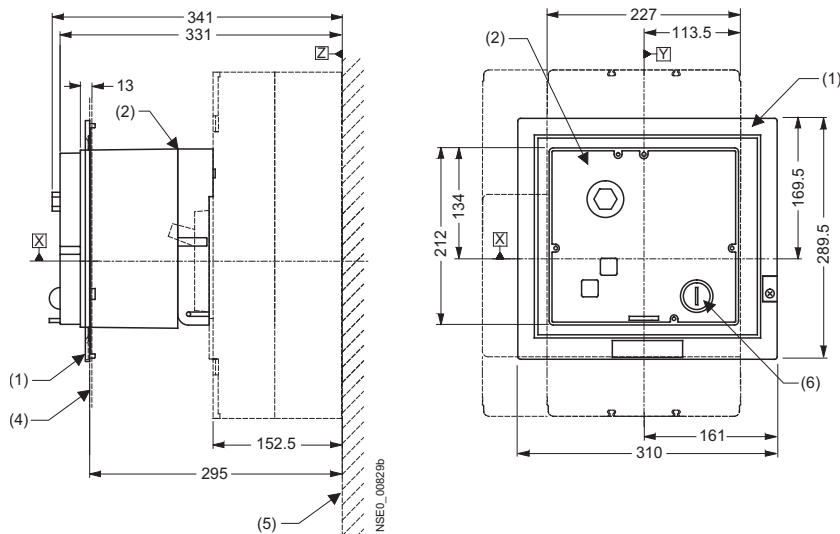

Front-operated rotary operating mechanism

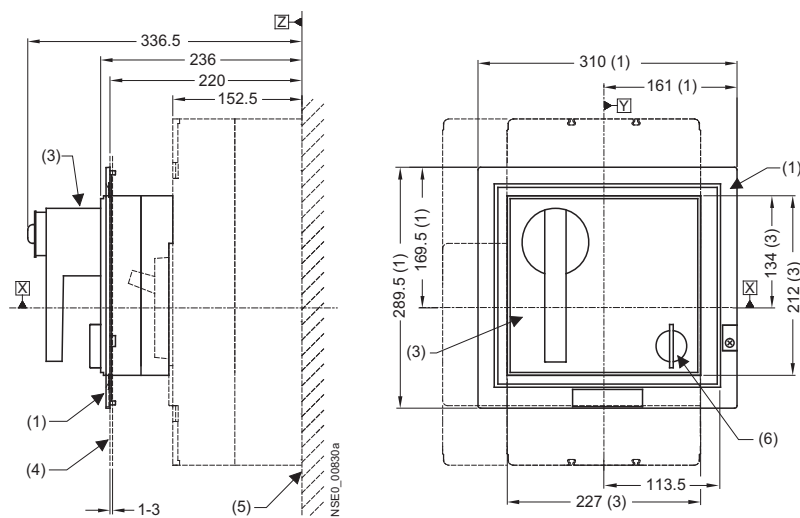

- (1) Masking frame for door cut-out
(for circuit breaker with operating mechanism)
- (2) Motorized operating mechanism
- (3) Front-operated rotary operating mechanism
- (4) Outside surface of cabinet door
- (5) Installation level
- (6) Safety lock

3VL Molded Case Circuit Breakers

3VL Molded Case Circuit Breakers up to 1600 A

Project planning aids

VL1250 (3VL7) and VL1600 (3VL8), 3- and 4-pole, up to 1600 A

Withdrawable versions

Withdrawable version with front-operated rotary operating mechanism
Insert position

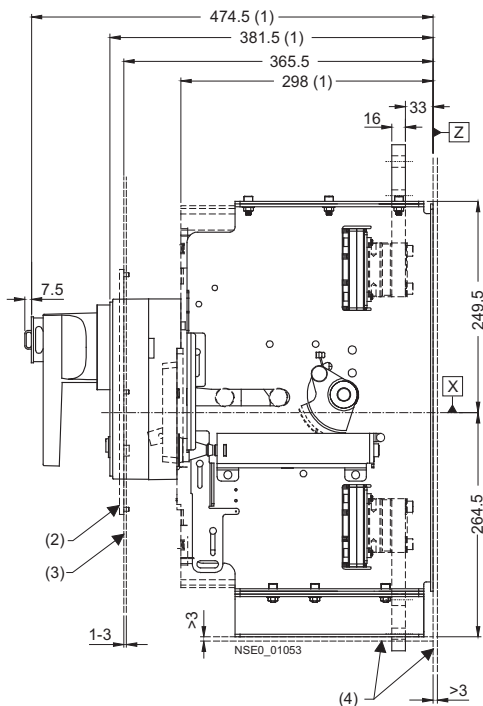

Withdrawable version with front-operated rotary operating mechanism
Withdraw position

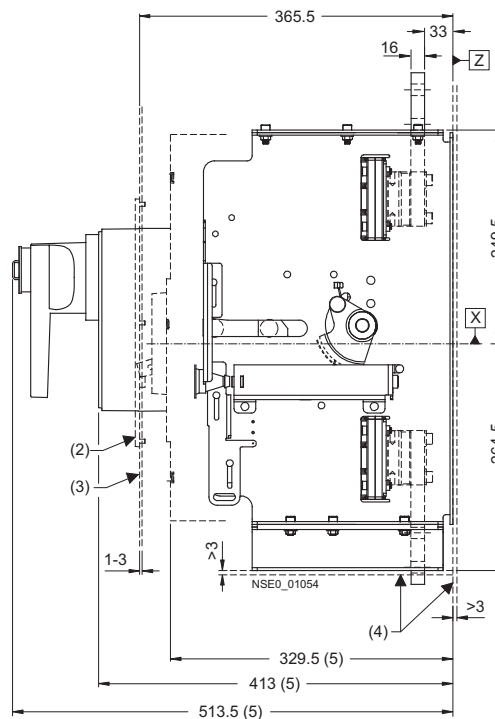

Withdrawable version with motorized operating mechanism with stored-energy mechanism
Insert position

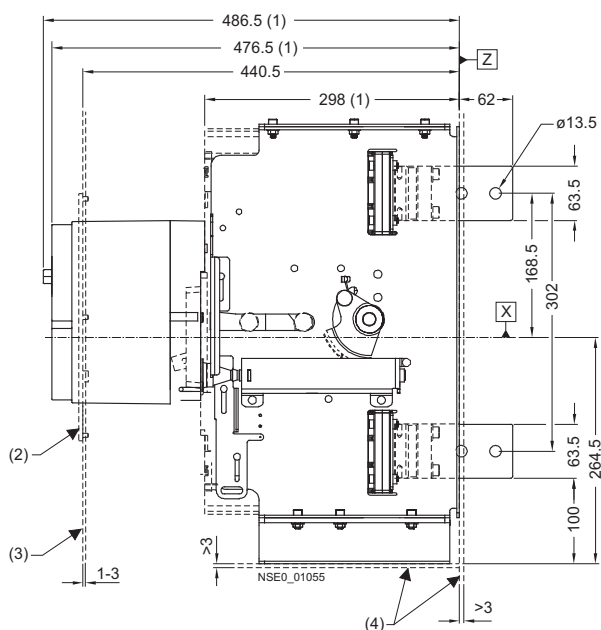

Withdrawable version with motorized operating mechanism with stored-energy mechanism
Withdraw position

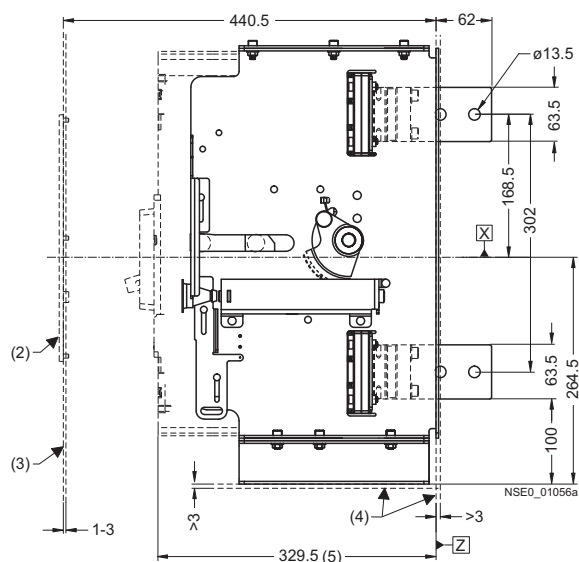

- (1) Connected position
- (2) Masking frame for door cut-out
- (3) Outside surface of cabinet door
- (4) Installation level
- (5) Disconnected position

3VL Molded Case Circuit Breakers

3VL Molded Case Circuit Breakers up to 1600 A

Project planning aids

VL1250 (3VL7) and VL1600 (3VL8), 3- and 4-pole, up to 1600 A Withdrawable versions

Withdrawable version with extended escutcheon (without masking frame)
Insert position

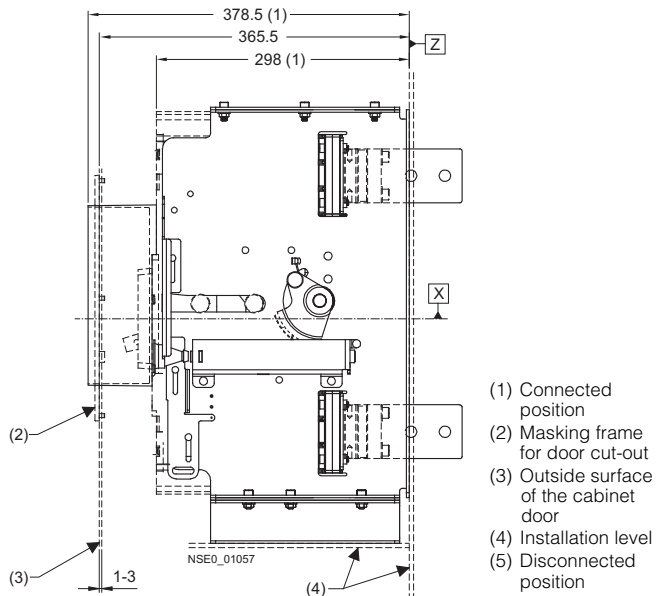

Withdrawable version with extended escutcheon (without masking frame)
Withdraw position

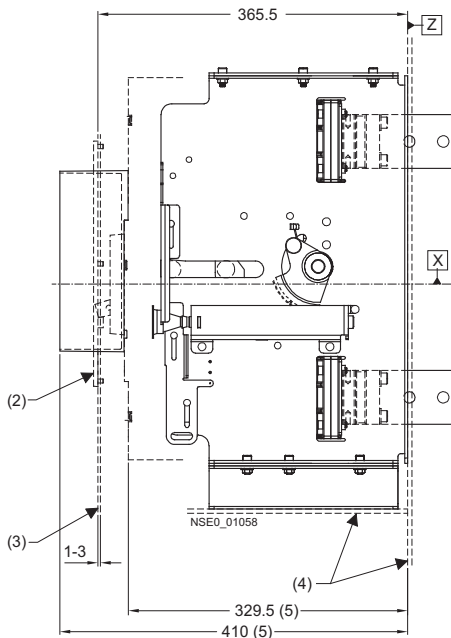

Withdrawable version

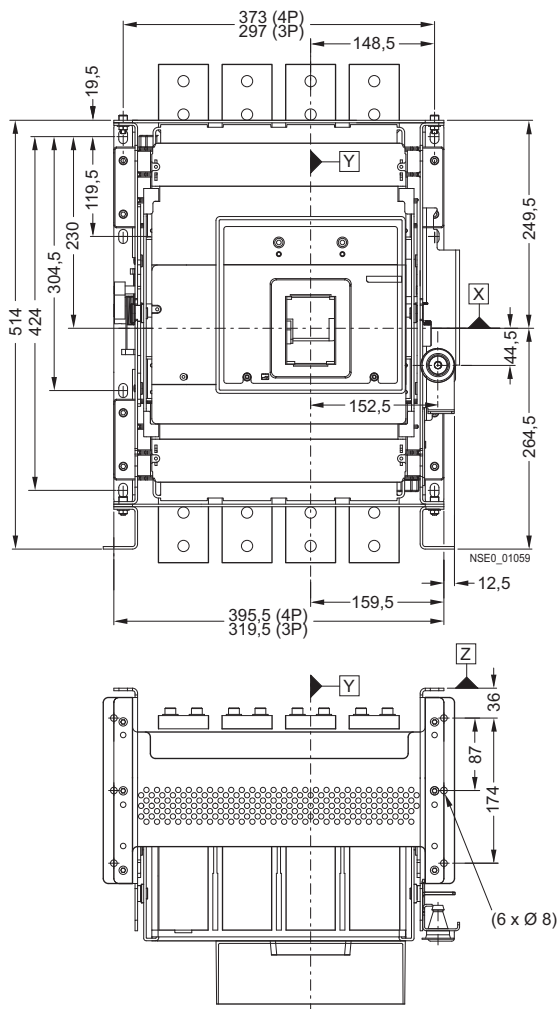

Hole pattern and cut-out for withdrawable versions
with rear flat bar connection

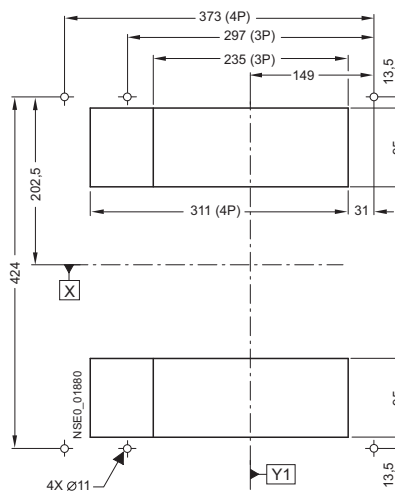

3VL Molded Case Circuit Breakers

3VL Molded Case Circuit Breakers up to 1600 A

Project planning aids

VL1250 (3VL7) and VL1600 (3VL8), 3- and 4-pole, up to 1600 A

Terminals and phase barriers

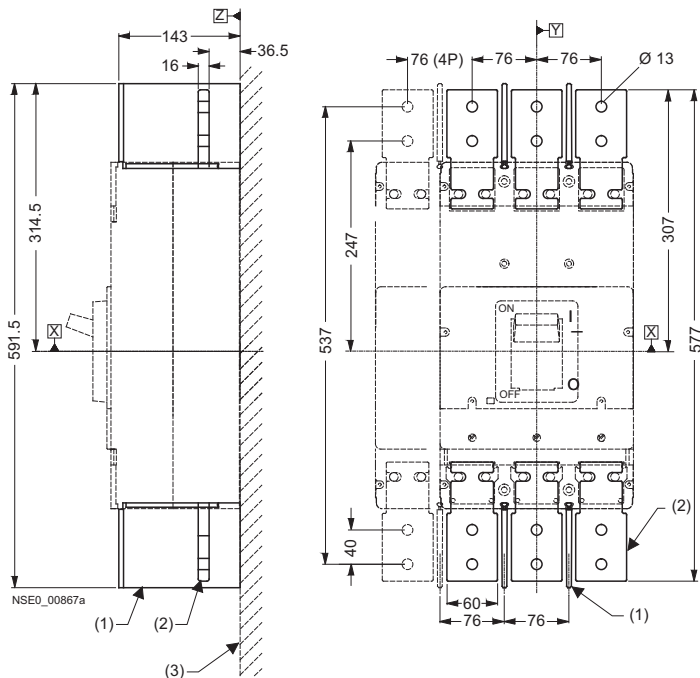

- (1) Phase barrier
- (2) Front connecting bars
- (3) Installation level

Terminal covers

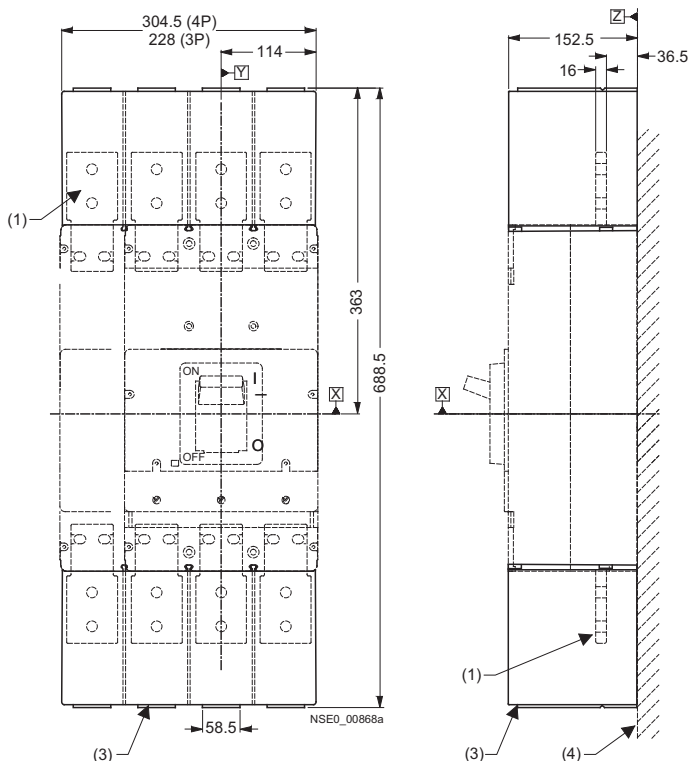

- (1) Front connecting bars
- (2) Terminal covers (short) – only for SENTRON VL1250 (3VL7) circuit breakers
- (3) Terminal covers (extended)
- (4) Installation level
- (5) Rear terminal (mounted horizontally)
- (6) Rear terminal (mounted vertically)
- (7) Phase barriers

3VL Molded Case Circuit Breakers

3VL Molded Case Circuit Breakers up to 1600 A

Project planning aids

VL1250 (3VL7) and VL1600 (3VL8), 3- and 4-pole, up to 1600 A

Terminal covers

Only SENTRON VL1250 (3VL7) circuit breakers

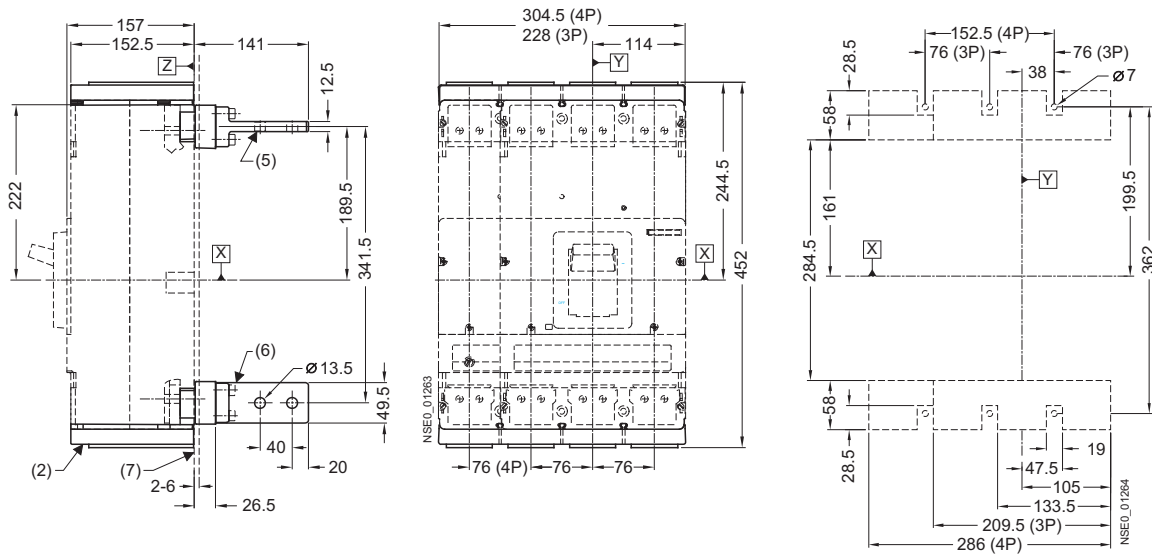

Only SENTRON VL1600 (3VL8) circuit breakers

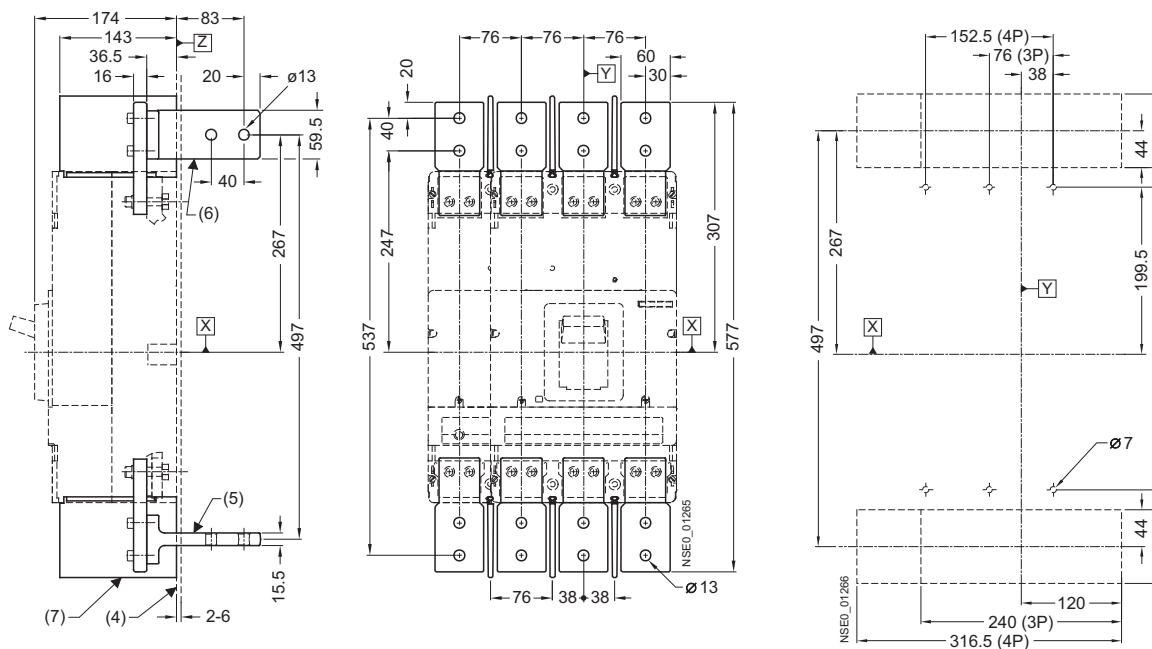

- (1) Front connecting bars
- (2) Terminal covers (short) – only for SENTRON VL1250 (3VL7) circuit breakers
- (3) Terminal covers (extended)
- (4) Installation level
- (5) Rear terminal (mounted horizontally)
- (6) Rear terminal (mounted vertically)
- (7) Phase barriers

3VL Molded Case Circuit Breakers

3VL Molded Case Circuit Breakers up to 1600 A

Project planning aids

VL1250 (3VL7) and VL1600 (3VL8), 3- and 4-pole, up to 1600 A

Rear interlocking modules

Rear interlocking module

For more detailed dimensional drawings see "Mounting Instructions for Rear Interlocking Module".

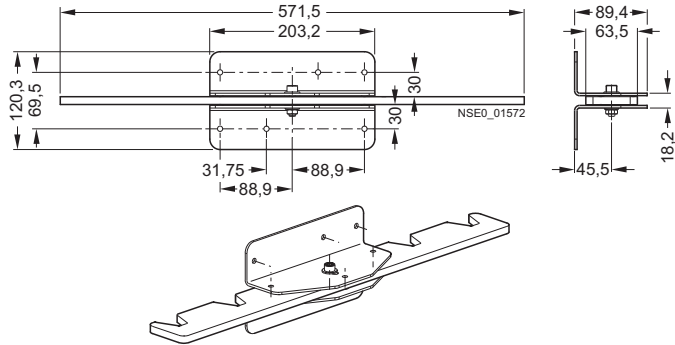

3-pole version

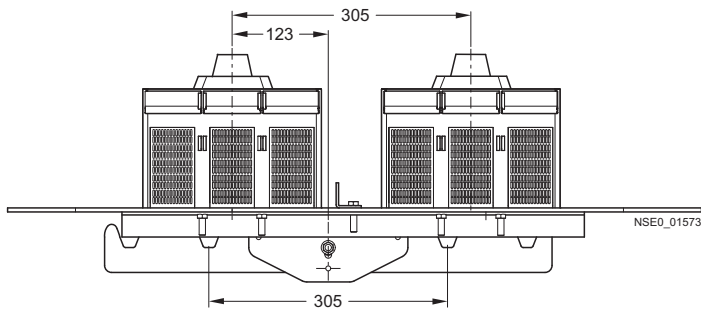

4-pole version

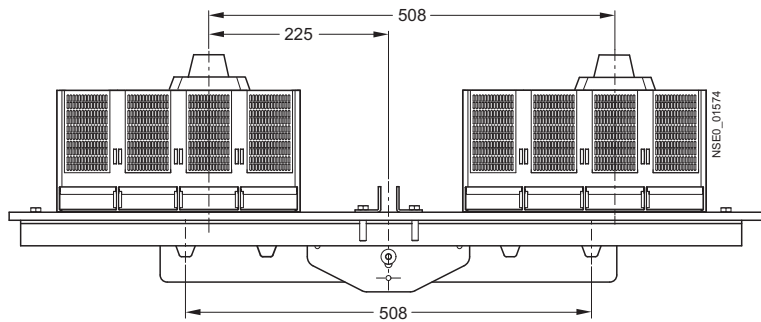

3VL Molded Case Circuit Breakers

3VL Molded Case Circuit Breakers up to 1600 A

Project planning aids

VL1250 (3VL7) and VL1600 (3VL8), 3- and 4-pole, up to 1600 A

Interlocks

Locking devices for toggle levers

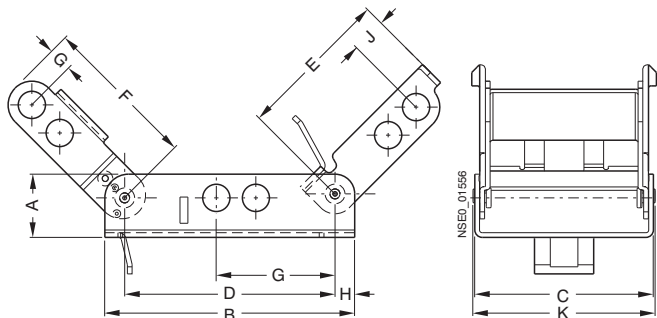

Type	a	b	c	d	e	f	g	h	i	k
3VL9 4	20.3	80.3	57.4	52.8	49.3	49.8	6.35	6.3	11.2	58.5
3VL9 6	21.6	79.8	71.1	62.0	50.4	46.5	12.9	8.9	8.6	72.2
3VL9 8	21.6	110.5	88.9	96.5	77.2	69.1	11.7	5.1	24.8	90.0

Accessories

Door-coupling rotary operating mechanism

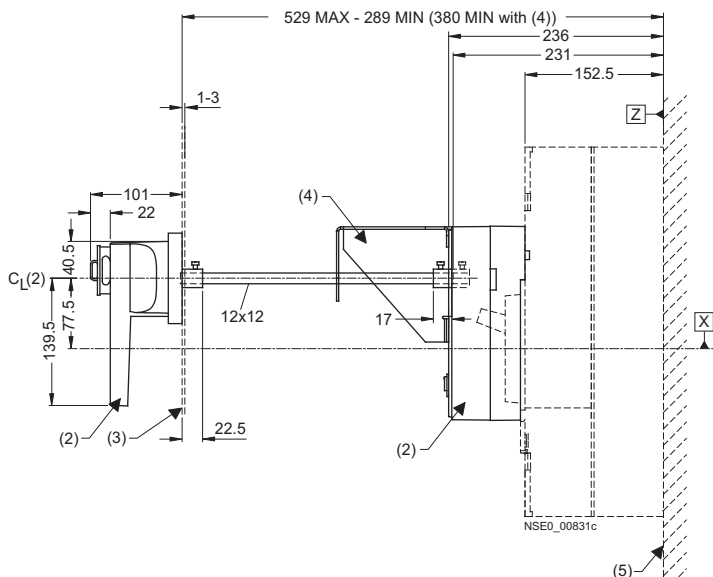

Masking frame for door cut-out for circuit breaker with toggle lever

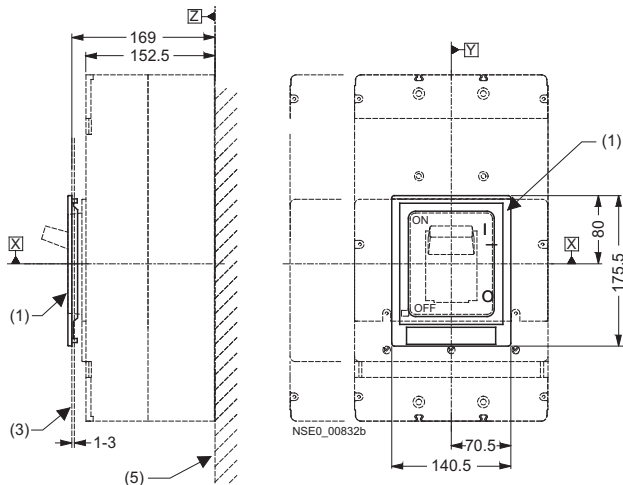

- (1) Masking frame for door cut-out (for circuit breaker with toggle lever)
- (2) Door-coupling rotary operating mechanism
- (3) Outside surface of cabinet door
- (4) Support bracket
- (5) Installation level

3VL Molded Case Circuit Breakers

3VL Molded Case Circuit Breakers up to 1600 A

Project planning aids

VL1250 (3VL7) and VL1600 (3VL8), 3- and 4-pole, up to 1600 A

Door cut-outs

Door cut-out for toggle lever (without masking frame)

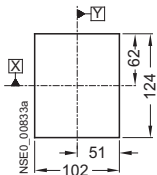

Door cut-out for front-operated rotary operating mechanism and motorized operating mechanism (without masking frame)

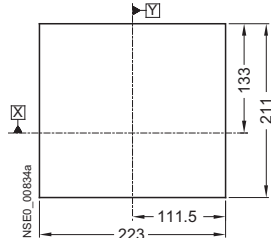

Door cut-out for door-coupling rotary operating mechanism

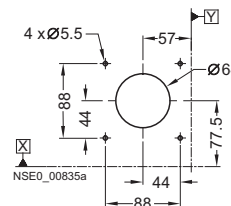

Door cut-out for toggle lever (with masking frame)

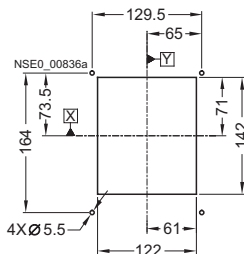

Door cut-out for front-operated rotary operating mechanism, motorized operating mechanism and extended escutcheon (with masking frame)

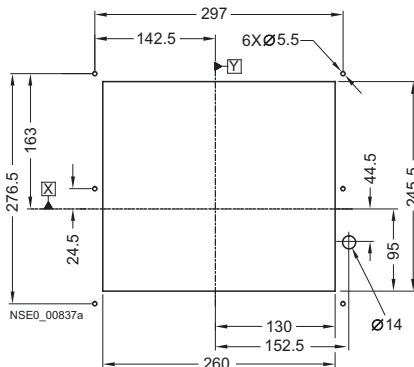

Current transformers

Current transformer for neutral conductors for ground-fault protection in 4-wire three-phase systems for SENTRON VL160 (3VL2)/VL250 (3VL3) circuit breakers

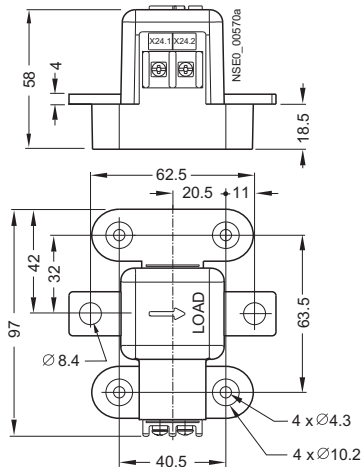

Current transformer for neutral conductors for ground-fault protection in 4-wire three-phase systems for SENTRON VL630 (3VL5)/VL800 (3VL6) circuit breakers

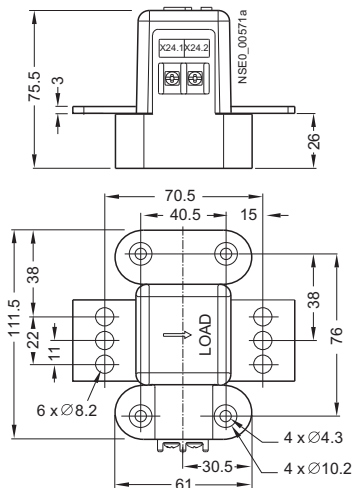

For more dimensional drawings (for current transformers for 3VL4, 3VL7, 3VL8) see mounting instruction for current transformers.

3VL Molded Case Circuit Breakers

3VL Molded Case Circuit Breakers up to 1600 A

Project planning aids

VL160X (3VL1) to VL800 (3VL6), 3- and 4-pole, up to 800 A

Interlock with Bowden wire

VL160X (3VL1),
VL160 (3VL2),
VL250 (3VL3)

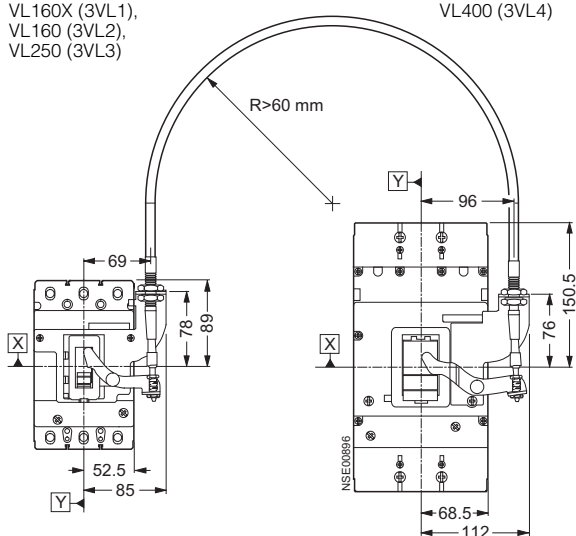

VL400 (3VL4)

VL800 (3VL6)

VL630 (3VL5)

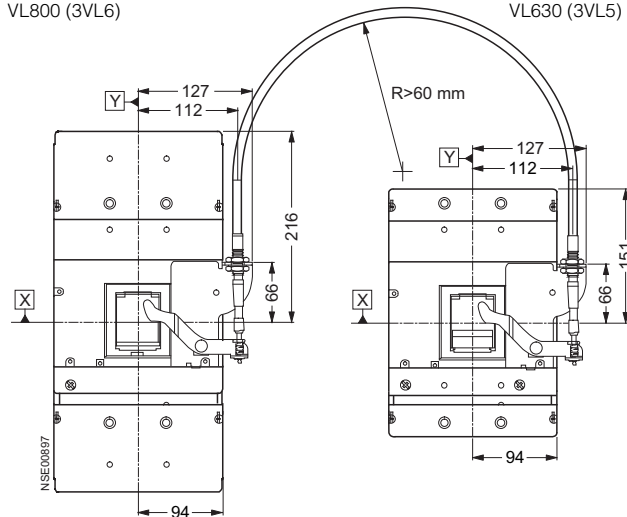

Combination options

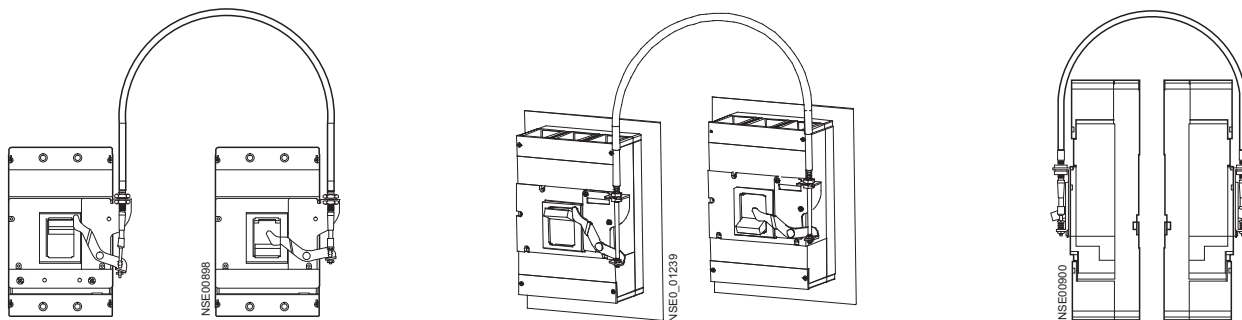

3VL9 300-8LA00 For VL160X (3VL1), VL160 (3VL2) and VL250 (3VL3)	3VL9 400-8LA00 For VL400 (3VL4)	3VL9 600-8LA00 For VL630 (3VL5) and VL800 (3VL6)	3VL9 800-8LA00 For VL1250 (3VL7) and VL1600 (3VL8)
--	------------------------------------	--	--

Interlock with Bowden wire

3VL9 300-8LA00 For VL160X (3VL1), VL160 (3VL2) and VL250 (3VL3)	✓	--	--	--
3VL9 400-8LA00 For VL400 (3VL4)	--	✓	--	--
3VL9 600-8LA00 For VL630 (3VL5) and VL800 (3VL6)	--	--	✓	--
3VL9 800-8LA00 For VL1250 (3VL7) and VL1600 (3VL8)	--	--	--	✓

✓ Combination possible

3VL Molded Case Circuit Breakers

3VL Molded Case Circuit Breakers up to 1600 A

Project planning aids

VL160X (3VL1) to VL400 (3VL4), 3- and 4-pole, up to 400 A

8US1 busbar adapter system

8US10 11-4SL01
(40 mm system)

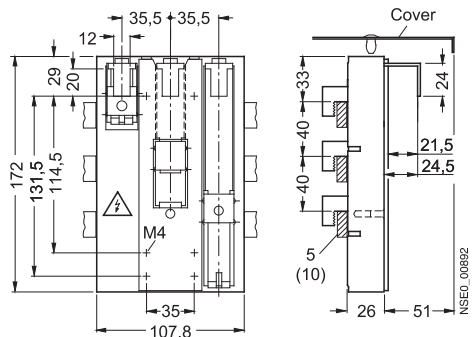

8US12 11-4SL01
(60 mm system)

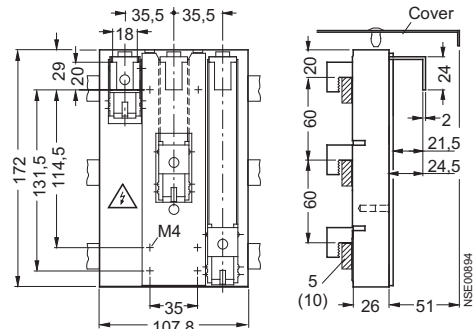

8US12 11-4SL00
(60 mm system)

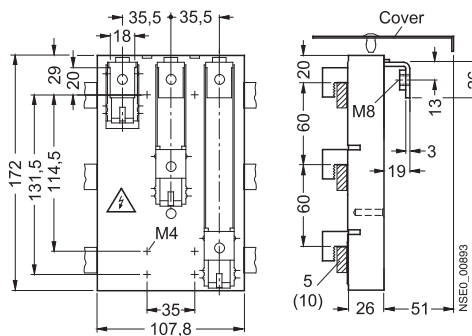

8US19 27-4AF01
(60 mm system)

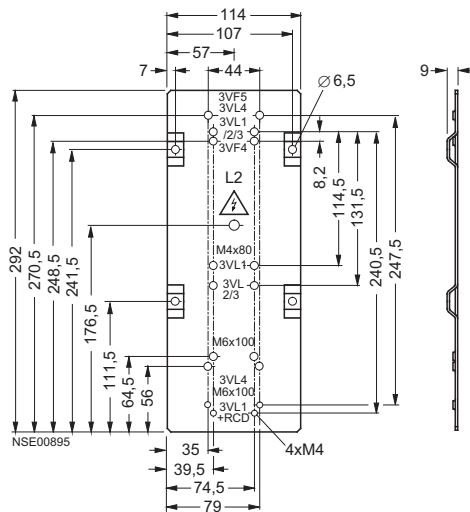

3VL Molded Case Circuit Breakers

3VL Molded Case Circuit Breakers up to 1600 A

Project planning aids

VL160X (3VL1) with RCD module, 3- and 4-pole, up to 160 A

Circuit breakers

SENTRON VL160X (3VL1) circuit breaker with RCD module

Circuit breaker installation instructions

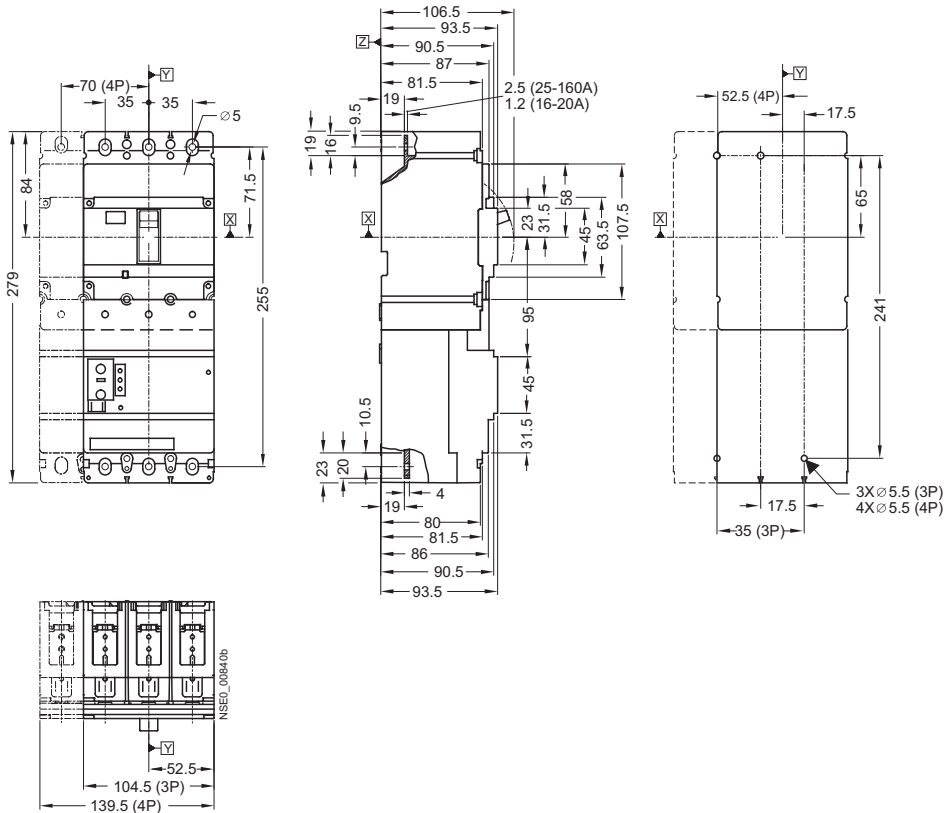

3VL Molded Case Circuit Breakers

3VL Molded Case Circuit Breakers up to 1600 A

Project planning aids

VL160X (3VL1) with RCD module, 3- and 4-pole, up to 160 A

Terminals and phase barriers

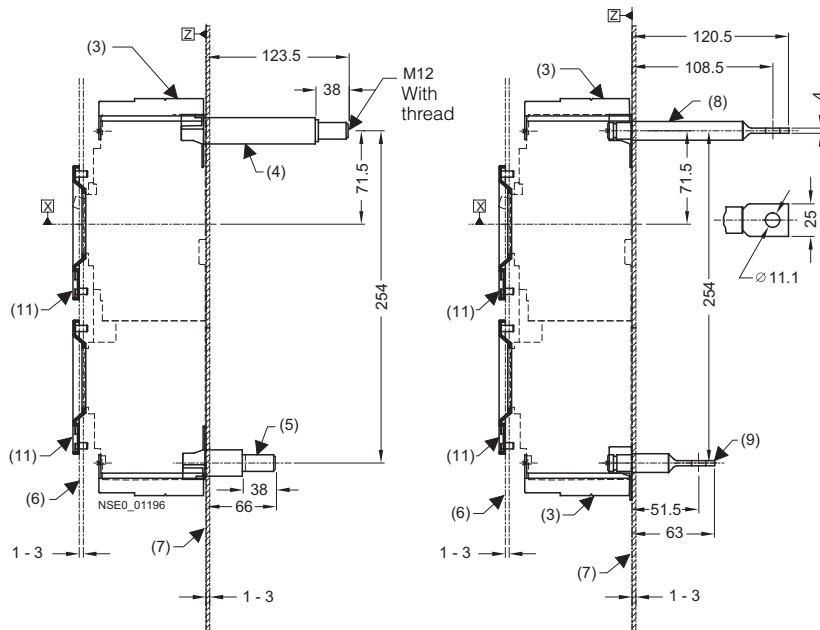
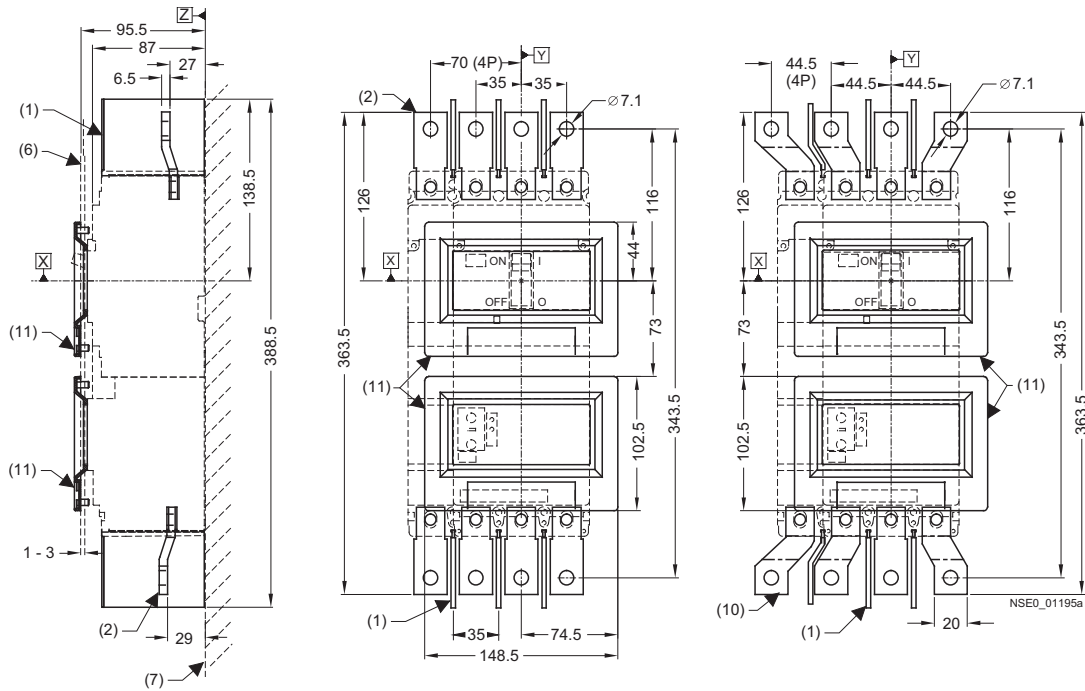

- (1) Phase barrier
- (2) Front connecting bars
- (3) Terminal covers (standard)
- (4) Threaded rear terminals, threaded bolt (long)
- (5) Threaded rear terminals, threaded bolt (short)
- (6) Outside surface of cabinet door
- (7) Installation level
- (8) Rear terminal, long flat connector
- (9) Rear terminal, short flat connector
- (10) Flared front busbar connecting bars
- (11) Masking frame for door cut-out
(for circuit breaker with RCD module)

3VL Molded Case Circuit Breakers

3VL Molded Case Circuit Breakers up to 1600 A

Project planning aids

VL160X (3VL1) with RCD module, 3- and 4-pole, up to 160 A

Terminal covers

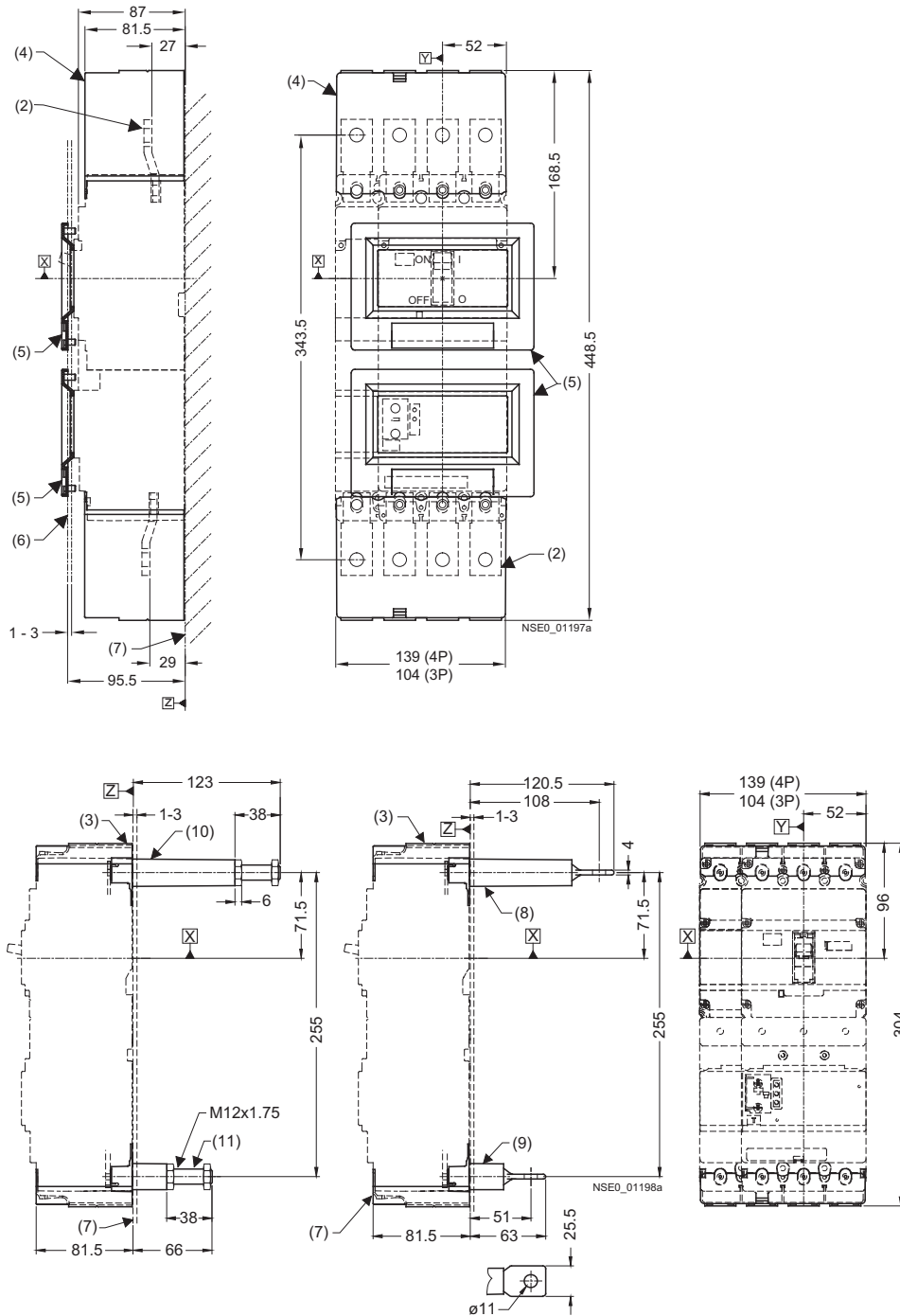

- (2) Front connecting bars
- (3) Terminal covers (standard)
- (4) Terminal covers (extended)
- (5) Masking frame for door cut-out
(for circuit breaker with RCD module)
- (6) Outside surface of cabinet door
- (7) Installation level
- (8) Rear terminal, long flat connector
- (9) Rear terminal, short flat connector
- (10) Rear terminal, long
- (11) Rear terminal, short

3VL Molded Case Circuit Breakers

3VL Molded Case Circuit Breakers up to 1600 A

Project planning aids

VL160X (3VL1) with RCD module, 3- and 4-pole, up to 160 A

Door cut-outs

Hole pattern, cut-out for rear terminals

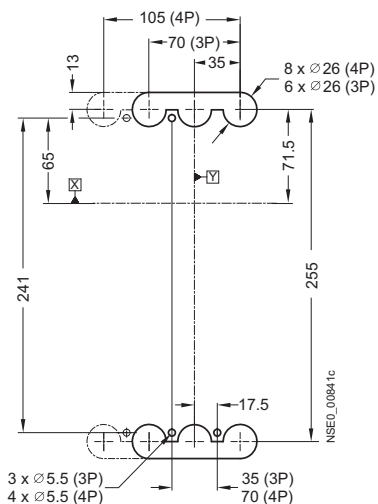

Door cut-out for toggle lever (with masking frame)

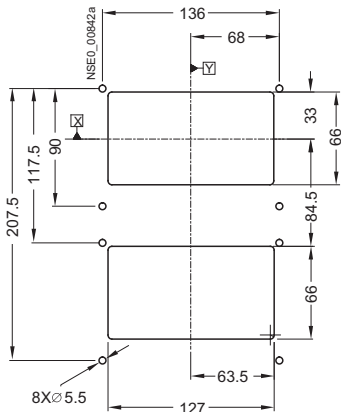

Door cut-out for toggle lever (without masking frame)

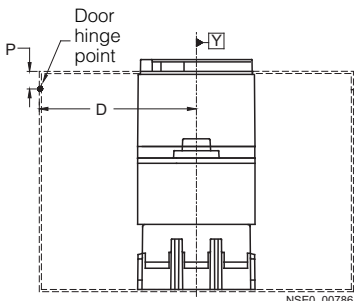
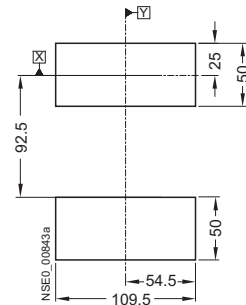

Note:
A minimum distance between reference point Y and the door hinge is required for the door cut-outs.

Combination	A
Circuit breaker only	100
Circuit breaker + plug-in base + motorized operating mechanism with stored-energy mechanism	100
Circuit breaker + plug-in base + front-operated rotary operating mechanism	200

D > A from table + (P x 5)

Circuit breaker with laterally attached RCD module

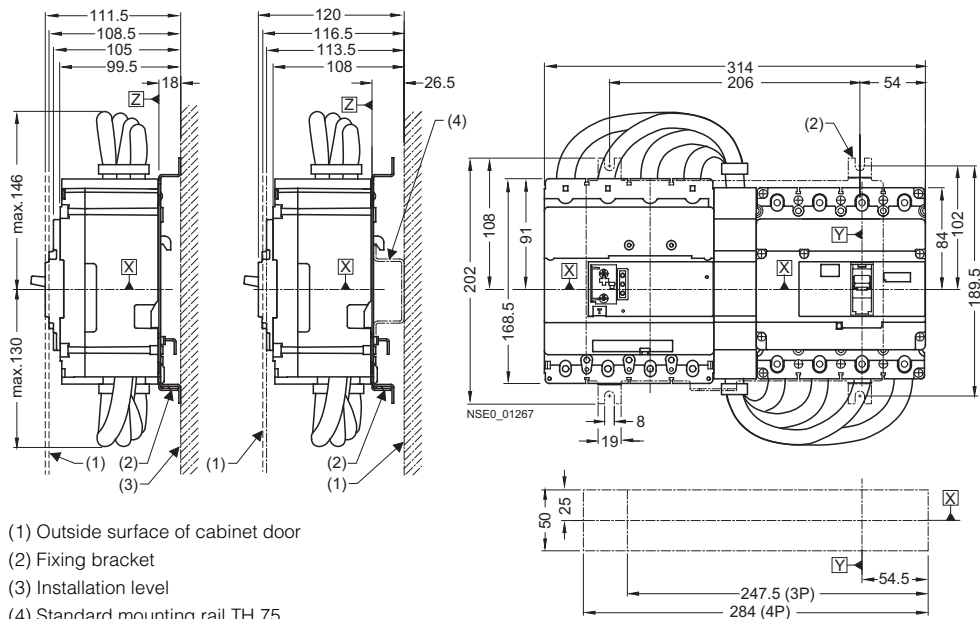

- (1) Outside surface of cabinet door
- (2) Fixing bracket
- (3) Installation level
- (4) Standard mounting rail TH 75 according to EN 60715 (to be provided by the customer)

3VL Molded Case Circuit Breakers

3VL Molded Case Circuit Breakers up to 1600 A

Project planning aids

VL160X (3VL1) with RCD module, 3- and 4-pole, up to 160 A

Plug-in bases and accessories

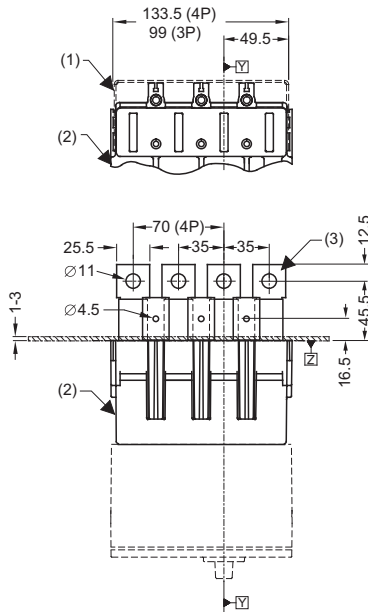
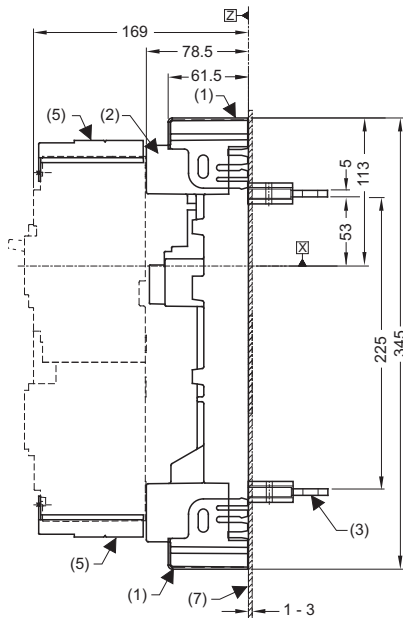

Hole pattern and cut-out for plug-in base with rear flat bar connection

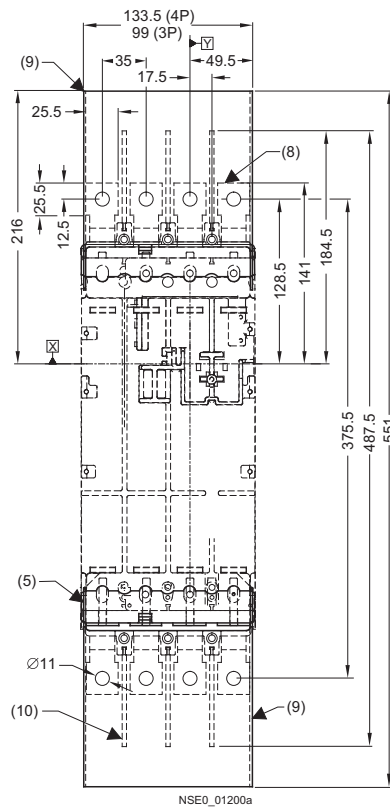
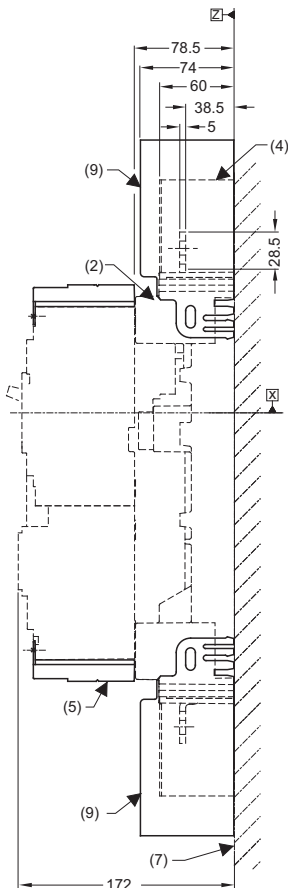
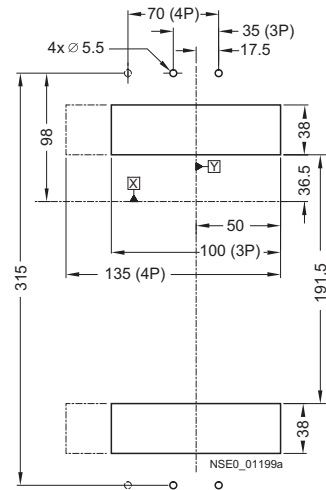

Hole pattern for plug-in base with front connecting bars

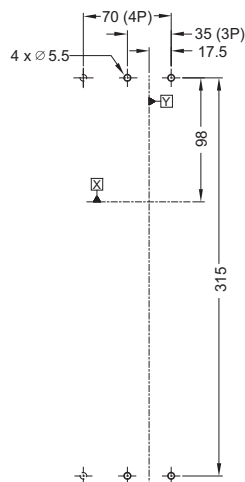

- (1) Plug-in base with rear terminal covers
- (2) Plug-in base for circuit breaker with RCD module
- (3) Plug-in base with rear flat bar connection
- (4) Masking frame for door cut-out (for circuit breaker with RCD module)
- (5) Terminal cover (standard)
- (6) Outside surface of cabinet door
- (7) Installation level
- (8) Plug-in base with front connecting bars
- (9) Plug-in base with terminal covers on the front
- (10) Phase barrier

3VL Molded Case Circuit Breakers

3VL Molded Case Circuit Breakers up to 1600 A

Project planning aids

VL160 (3VL2) and VL250 (3VL3) with RCD module, 3- and 4-pole, up to 250 A

Circuit breakers

SENTRON VL160 (3VL2) and VL250 (3VL3) circuit breakers with RCD module

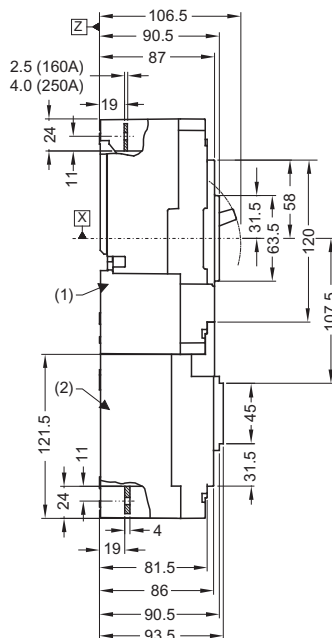
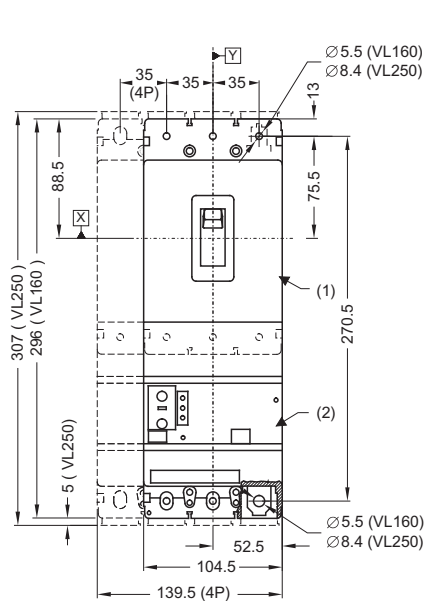

Circuit breaker installation instructions

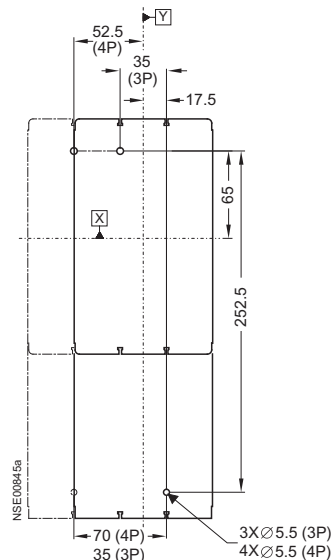

- (1) Circuit breaker
- (2) RCD module

Note for the SENTRON VL250 (3VL3) circuit breaker: The 5 mm extension (overall height 307 mm) at each end only applies when using box terminals and circular conductor terminals.

3VL Molded Case Circuit Breakers

3VL Molded Case Circuit Breakers up to 1600 A

Project planning aids

VL160 (3VL2) and VL250 (3VL3) with RCD module, 3- and 4-pole, up to 250 A

Terminals and phase barriers

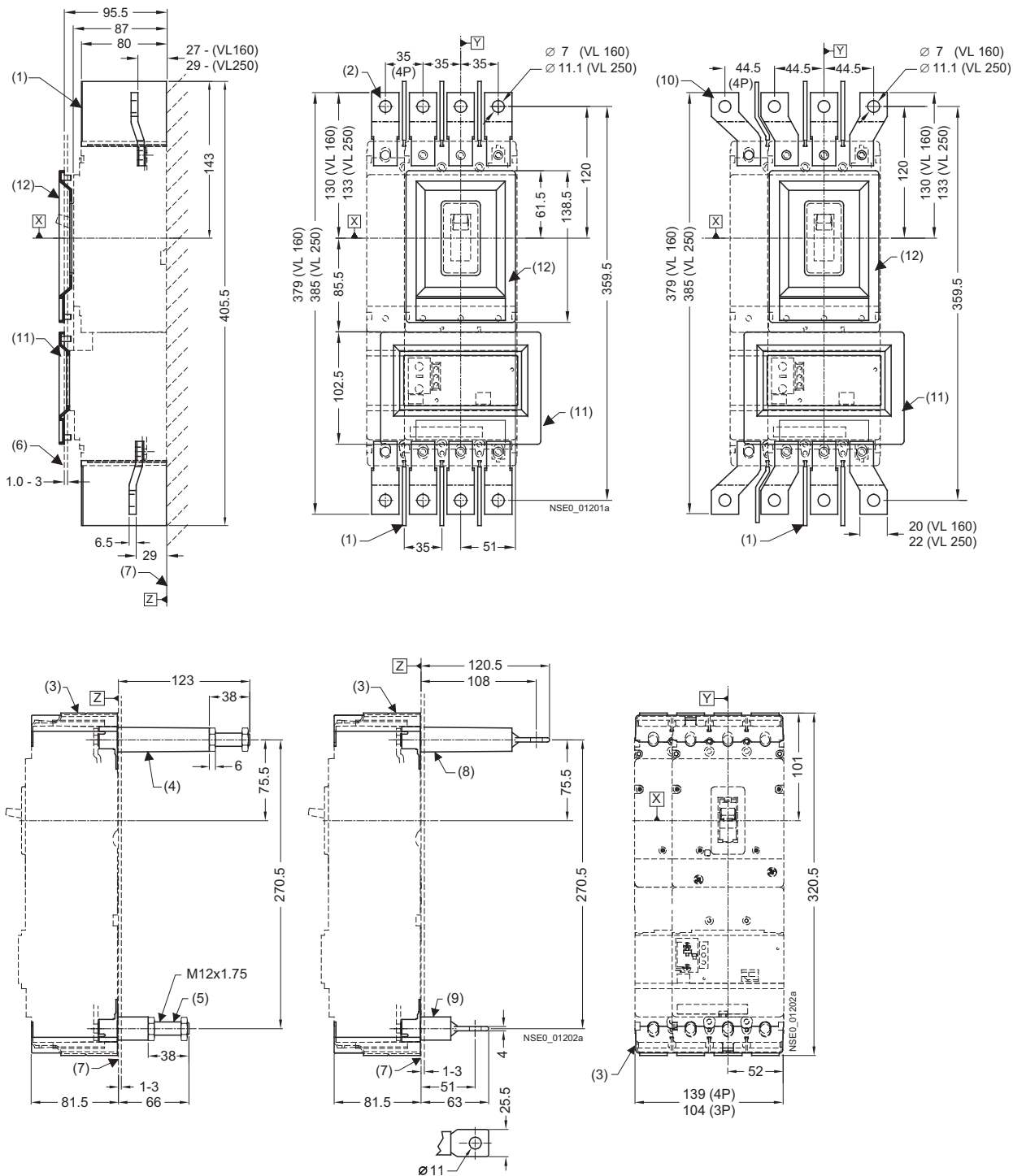

- (1) Phase barrier
- (2) Front connecting bars
- (3) Terminal covers (standard)
- (4) Rear terminals (long)
- (5) Rear terminals (short)
- (6) Outside surface of cabinet door
- (7) Installation level
- (8) Rear flat connector (long)
- (9) Rear flat connector (short)
- (10) Flared front busbar connecting bars
- (11) Masking frame for door cut-out (for circuit breaker with RCD module)
- (12) Masking frame for door cut-out (for circuit breaker with toggle lever)

3VL Molded Case Circuit Breakers

3VL Molded Case Circuit Breakers up to 1600 A

Project planning aids

VL160 (3VL2) and VL250 (3VL3) with RCD module, 3- and 4-pole, up to 250 A

Terminal covers

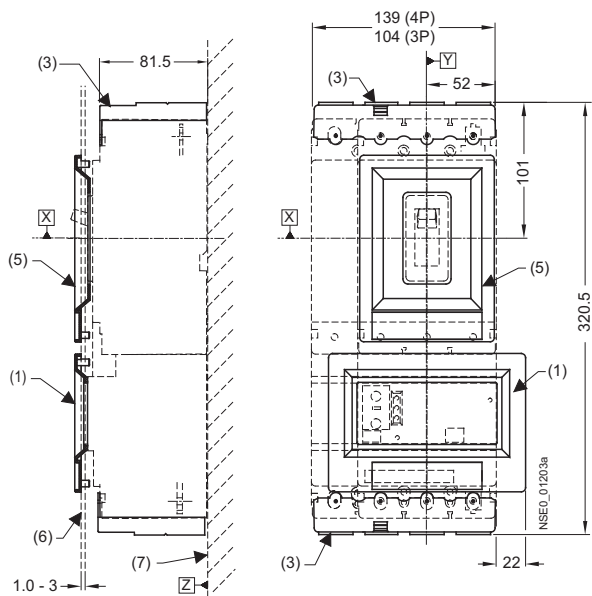

For dimensions of the lower masking frame, "VL160X (3VL1) with RCD module, 3- and 4-pole, up to 160 A", "Terminal covers", see bottom of page 16/75.

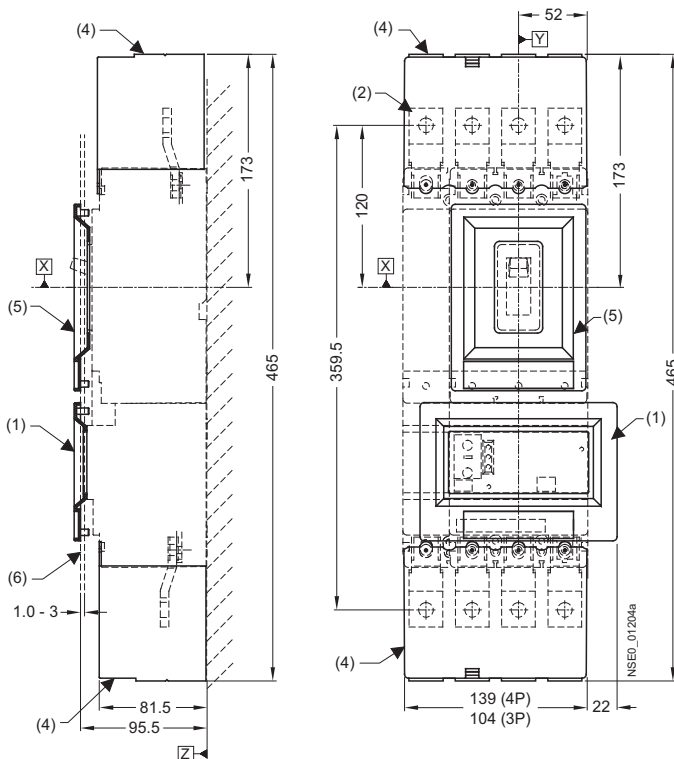

- (1) Masking frame for door cut-out (for circuit breaker with RCD module)
- (2) Front connecting bars
- (3) Terminal covers (standard)
- (4) Terminal covers (extended)
- (5) Masking frame for door cut-out (for circuit breaker with toggle lever)
- (6) Outside surface of cabinet door
- (7) Installation level

3VL Molded Case Circuit Breakers

3VL Molded Case Circuit Breakers up to 1600 A

Project planning aids

VL160 (3VL2) and VL250 (3VL3) with RCD module, 3- and 4-pole, up to 250 A

Door cut-outs

Door cut-out for toggle lever (without masking frame)

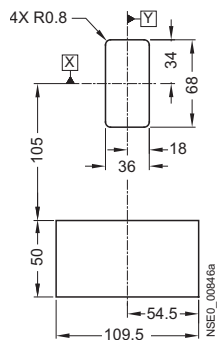

Door cut-out for toggle lever (with masking frame)

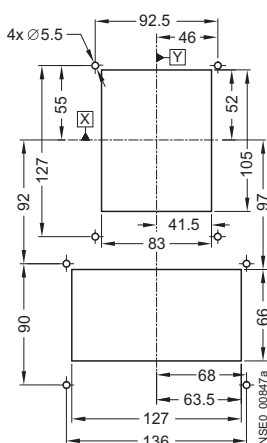

Door cut-out for door-coupling rotary operating mechanism

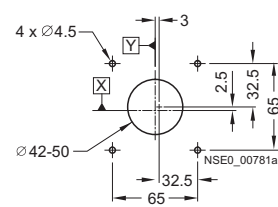

Door cut-out for front-operated rotary operating mechanism and motorized operating mechanism with stored-energy mechanism (with masking frame)

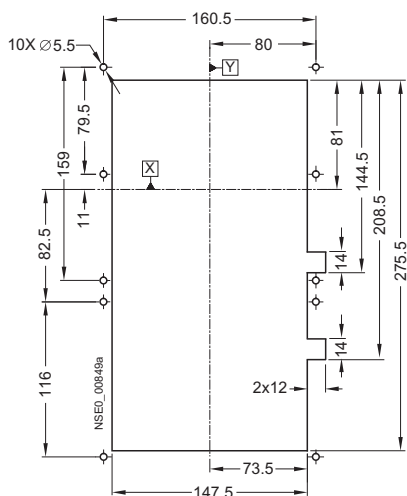

Door cut-out for front-operated rotary operating mechanism (without masking frame)

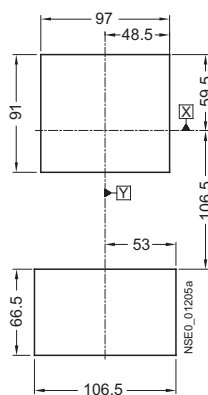

Hole pattern, cut-out for rear terminal studs

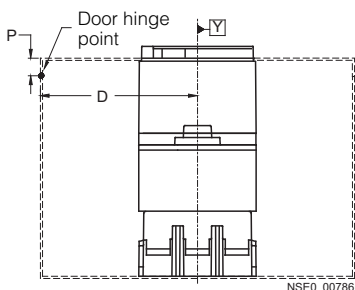
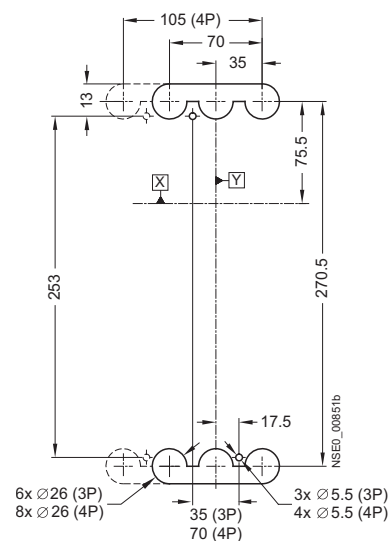

Note:
A minimum distance between reference point Y and the door hinge is required for the door cut-outs.

$D > A$ from table + $(P \times 5)$

Combination	A
Circuit breaker only	100
Circuit breaker + plug-in base + motorized operating mechanism with stored-energy mechanism	100
Circuit breaker + plug-in base + front-operated rotary operating mechanism	200
Circuit breaker + withdrawable version	200

3VL Molded Case Circuit Breakers

3VL Molded Case Circuit Breakers up to 1600 A

Project planning aids

VL160 (3VL2) and VL250 (3VL3) with RCD module, 3- and 4-pole, up to 250 A

Plug-in bases and accessories

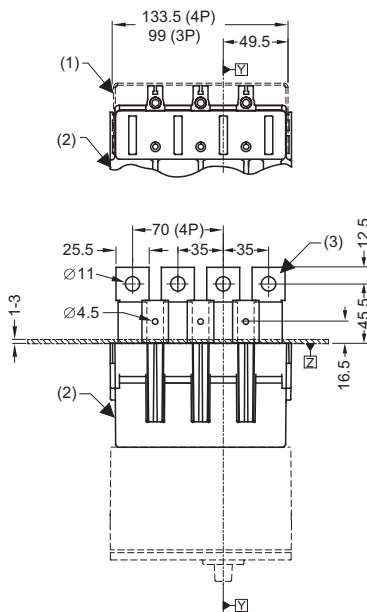
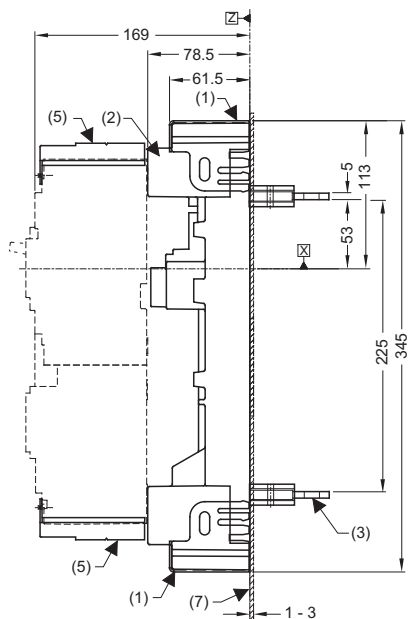

Hole pattern and cut-out for plug-in base with rear flat bar connection

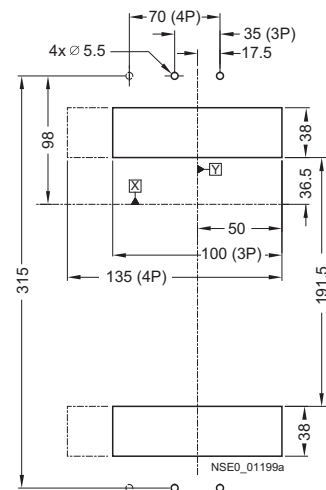

16

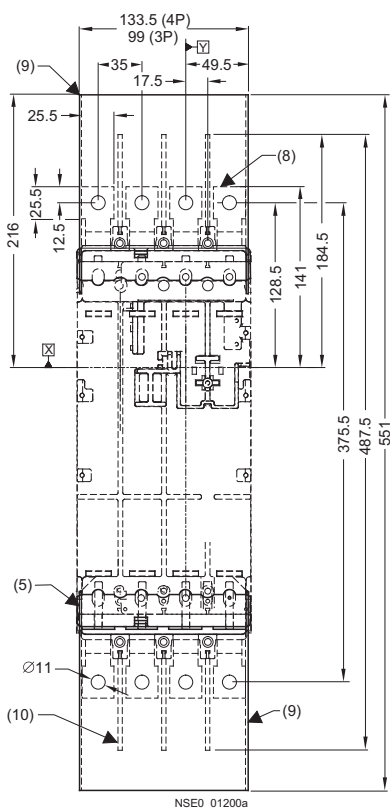
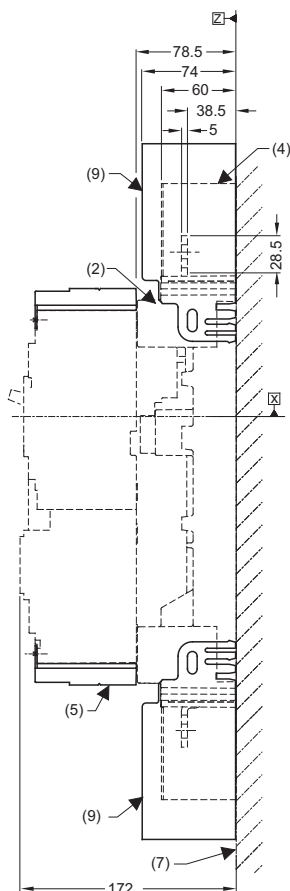

Hole pattern for plug-in base with front connecting bars

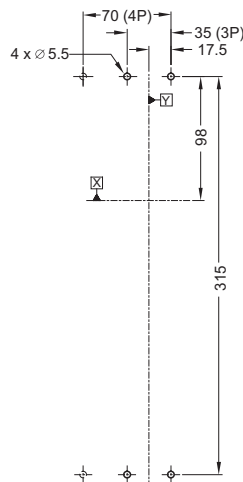

- (1) Plug-in base with rear terminal covers
- (2) Plug-in base for circuit breaker with RCD module
- (3) Plug-in base with rear flat bar connection
- (4) Masking frame for door cut-out (for circuit breaker with RCD module)
- (5) Terminal cover (standard)
- (6) Outside surface of cabinet door
- (7) Installation level
- (8) Plug-in base with front connecting bars
- (9) Plug-in base with terminal covers on the front
- (10) Phase barrier

3VL Molded Case Circuit Breakers

3VL Molded Case Circuit Breakers up to 1600 A

Project planning aids

VL160 (3VL2) and VL250 (3VL3) with RCD module, 3- and 4-pole, up to 250 A

Plug-in bases and accessories

SENTRON VL160 (3VL2) and VL250 (3VL3) circuit breakers with RCD module and motorized operating mechanism with stored-energy mechanism (connected position)

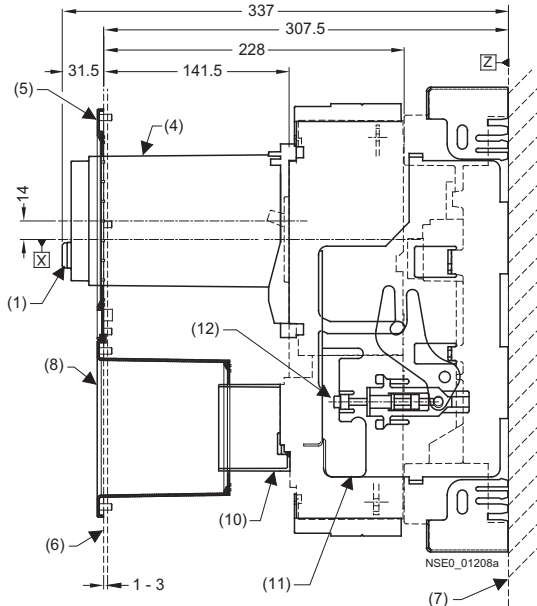

SENTRON VL160 (3VL2) and VL250 (3VL3) circuit breakers with RCD module and motorized operating mechanism with stored-energy mechanism (disconnected position)

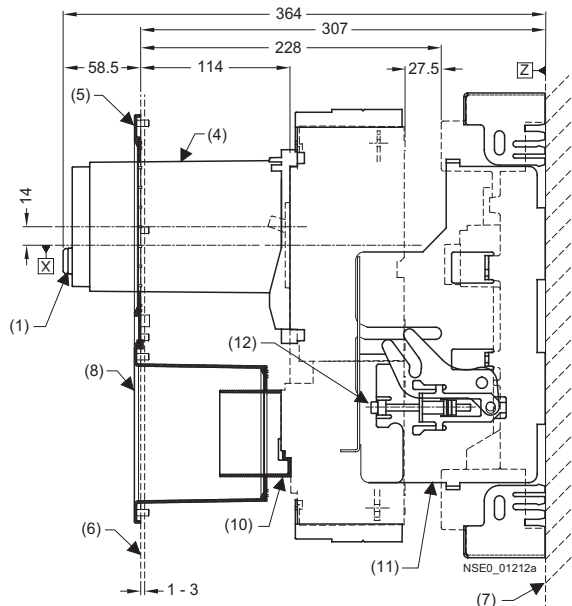

SENTRON VL160 (3VL2) and VL250 (3VL3) circuit breakers with RCD module and front-operated rotary operating mechanism (connected position)

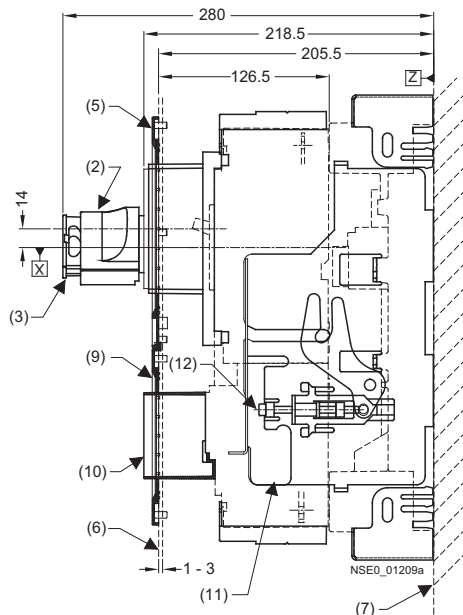

SENTRON VL160 (3VL2) and VL250 (3VL3) circuit breakers with RCD module and front-operated rotary operating mechanism (disconnected position)

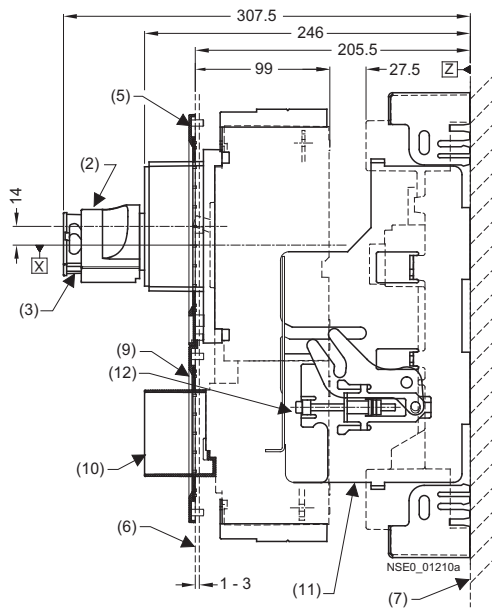

- (1) Safety lock
- (2) Front-operated rotary operating mechanism
- (3) Padlock
- (4) Motorized operating mechanism with stored-energy mechanism
- (5) Masking frame for door cut-out (for circuit breaker with operating mechanism)
- (6) Outside surface of cabinet door
- (7) Installation level
- (8) Masking frame for door cut-out (for circuit breaker with RCD module, motorized operating mechanism)
- (9) Masking frame for door cut-out (for circuit breaker with RCD module, toggle lever/rotary operating mechanism)
- (10) RCD extended escutcheon
- (11) Locking device for racking mechanism
- (12) Racking mechanism

3VL Molded Case Circuit Breakers

3VL Molded Case Circuit Breakers up to 1600 A

Project planning aids

VL160 (3VL2) and VL250 (3VL3) with RCD module, 3- and 4-pole, up to 250 A

Plug-in bases and accessories

SENTRON VL160 (3VL2) and VL250 (3VL3) circuit breakers with RCD module and extended escutcheon (connected position)

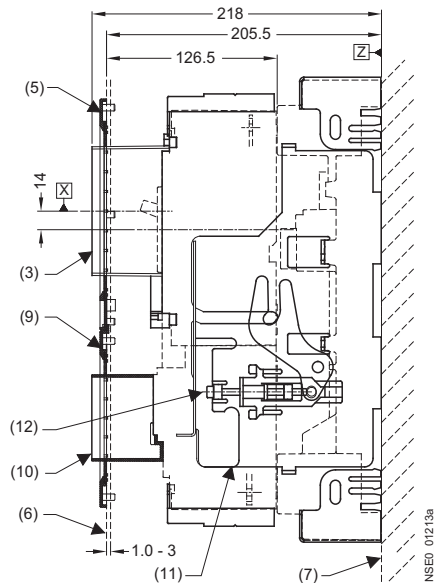

SENTRON VL160 (3VL2) and VL250 (3VL3) circuit breakers with RCD module and extended escutcheon (disconnected position)

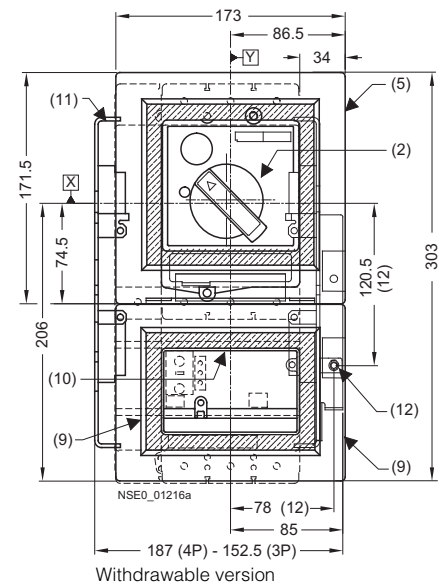
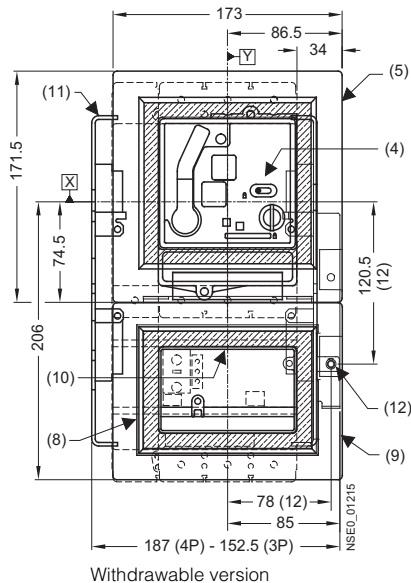
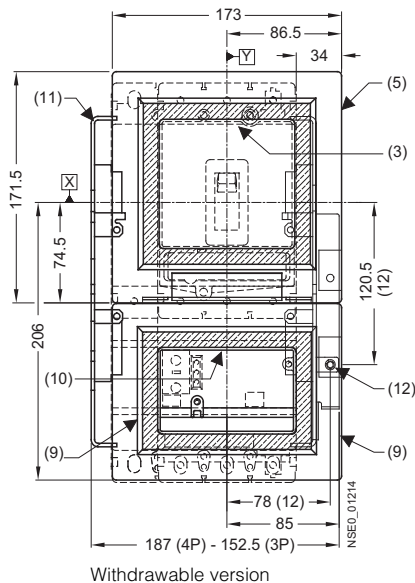
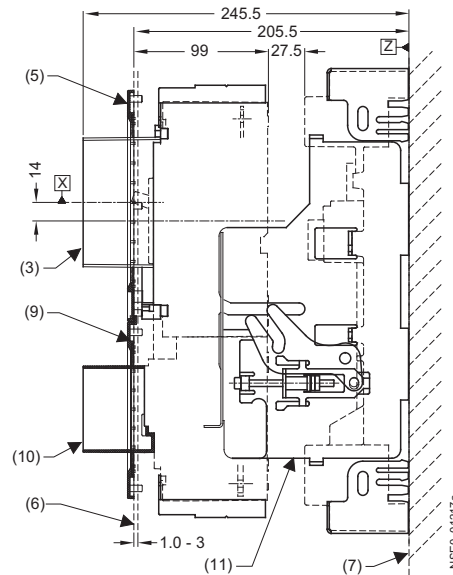

- (2) Front-operated rotary operating mechanism
- (3) Circuit breaker extended escutcheon
- (4) Motorized operating mechanism with stored-energy mechanism
- (5) Masking frame for door cut-out (for circuit breaker with operating mechanism)
- (6) Outside surface of cabinet door
- (7) Installation level
- (8) Masking frame for door cut-out (for circuit breaker with RCD module, motorized operating mechanism)
- (9) Masking frame for door cut-out (for circuit breaker with RCD module, toggle lever/rotary operating mechanism)
- (10) RCD extended escutcheon
- (11) Locking device for racking mechanism
- (12) Racking mechanism

3VL Molded Case Circuit Breakers

3VL Molded Case Circuit Breakers up to 1600 A

Project planning aids

VL400 (3VL4) with RCD module, 3- and 4-pole, up to 400 A

Circuit breakers

SENTRON VL400 (3VL4) circuit breaker with RCD module

Mounting hole pattern for SENTRON VL400 (3VL4) circuit breaker with RCD front connecting bar

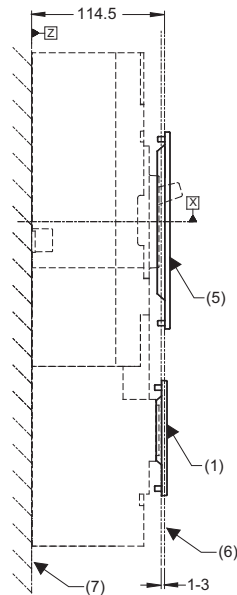
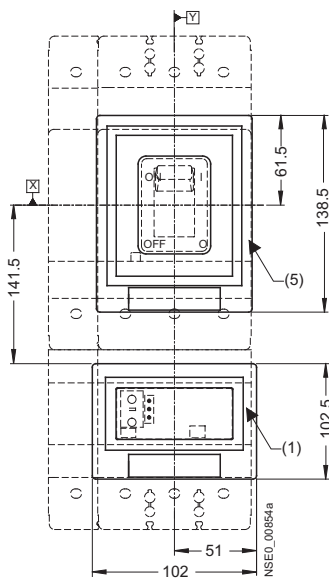
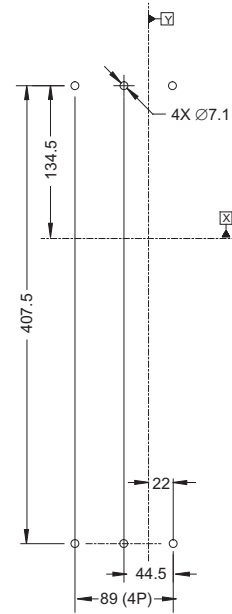
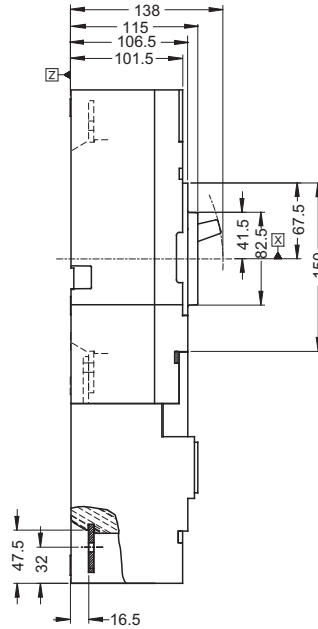
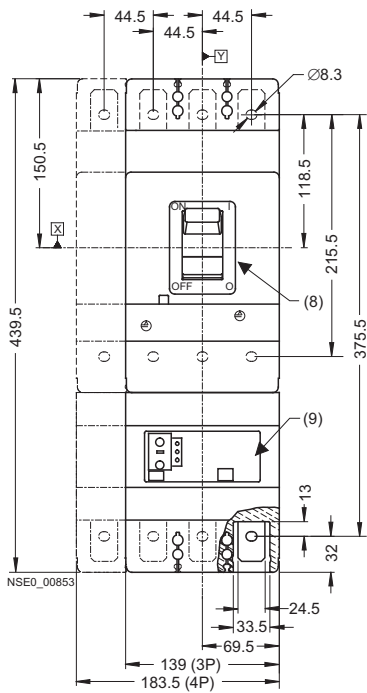

- (1) Masking frame for door cut-out (for circuit breaker with RCD module)
- (5) Masking frame for door cut-out (for circuit breaker with toggle lever)
- (6) Outside surface of cabinet door
- (7) Installation level
- (8) Circuit breaker
- (9) RCD module

3VL Molded Case Circuit Breakers

3VL Molded Case Circuit Breakers up to 1600 A

Project planning aids

VL400 (3VL4) with RCD module, 3- and 4-pole, up to 400 A

Terminals and phase barriers

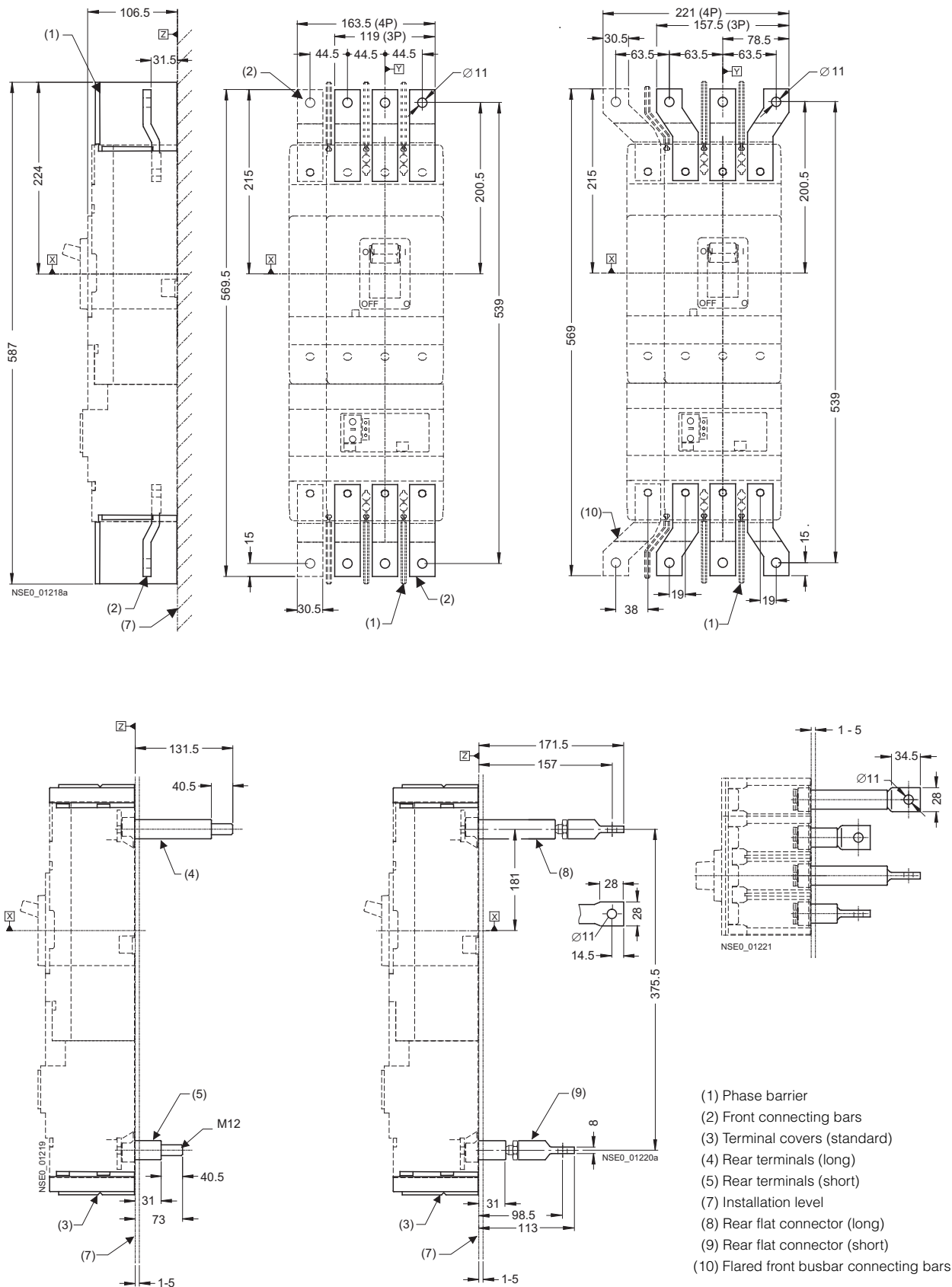

3VL Molded Case Circuit Breakers

3VL Molded Case Circuit Breakers up to 1600 A

Project planning aids

VL400 (3VL4) with RCD module, 3- and 4-pole, up to 400 A

Terminal covers

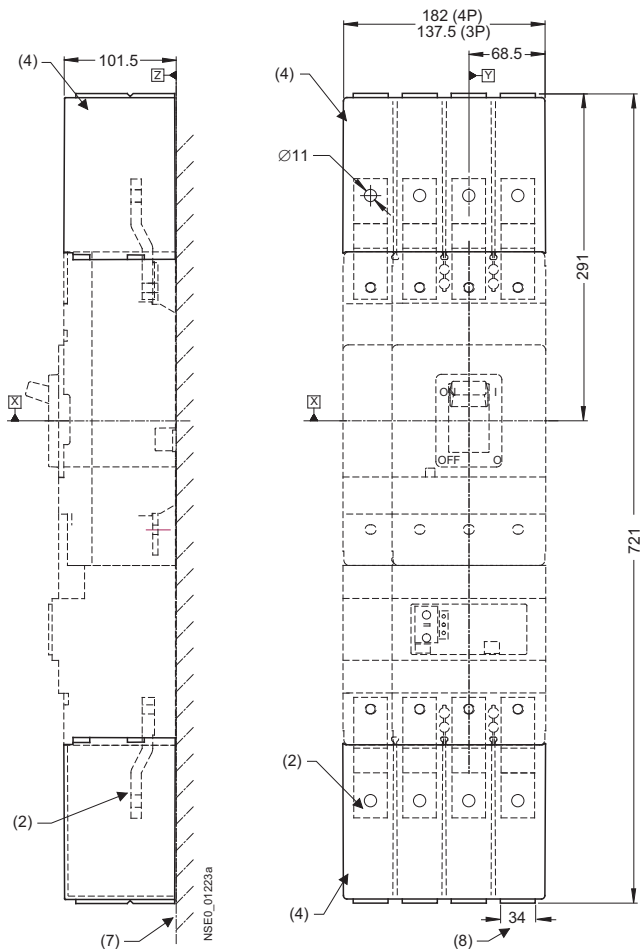
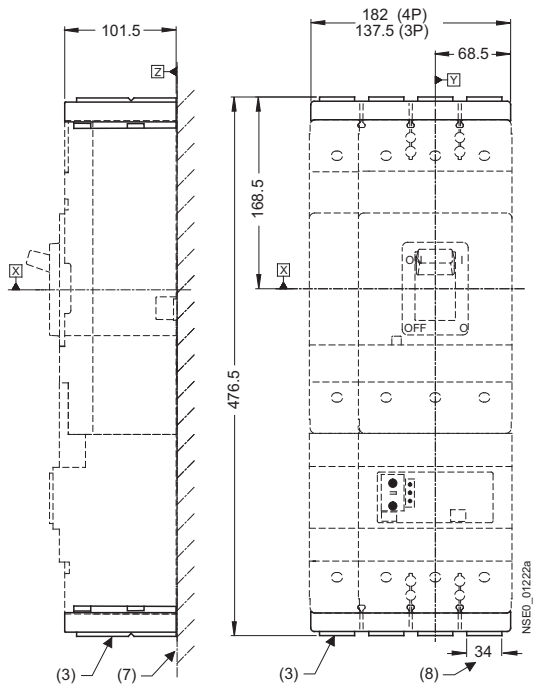

- (2) Front connecting bars
- (3) Terminal covers (standard)
- (4) Terminal covers (extended)
- (7) Installation level
- (8) Cut-out

3VL Molded Case Circuit Breakers

3VL Molded Case Circuit Breakers up to 1600 A

Project planning aids

VL400 (3VL4) with RCD module, 3- and 4-pole, up to 400 A

Door cut-outs

Door cut-out for toggle lever (with masking frame)

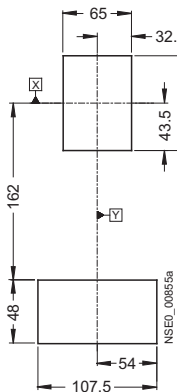

Door cut-out for front-operated rotary operating mechanism (without masking frame)

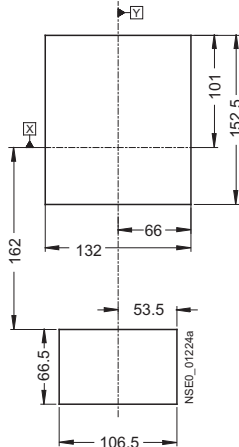

Door cut-out for door-coupling rotary operating mechanism

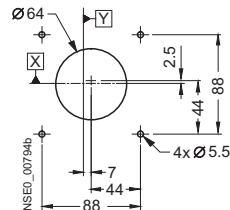

Door cut-out for front-operated rotary operating mechanism, motorized operating mechanism with stored-energy mechanism and extended escutcheon (with masking frame)

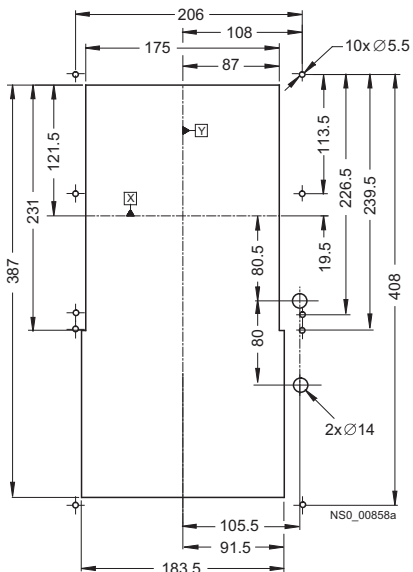

Hole pattern and cut-out for rear terminal studs

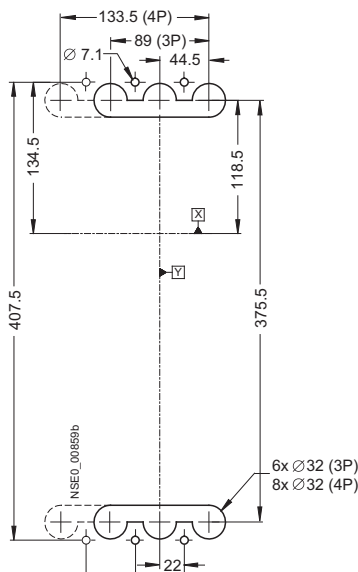

Door cut-out for toggle lever (with masking frame)

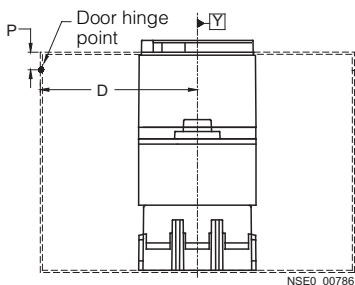
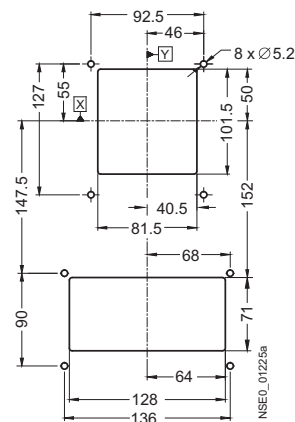

Note:
A minimum distance between reference point Y and the door hinge is required for the door cut-outs.

D > A from table + (P × 5)

Combination	A
Circuit breaker only	150
Circuit breaker + plug-in base + motorized operating mechanism with stored-energy mechanism	150
Circuit breaker + plug-in base + front-operated rotary operating mechanism	200
Circuit breaker + withdrawable version	200

16

3VL Molded Case Circuit Breakers

3VL Molded Case Circuit Breakers up to 1600 A

Project planning aids

VL400 (3VL4) with RCD module, 3- and 4-pole, up to 400 A

Plug-in bases and accessories

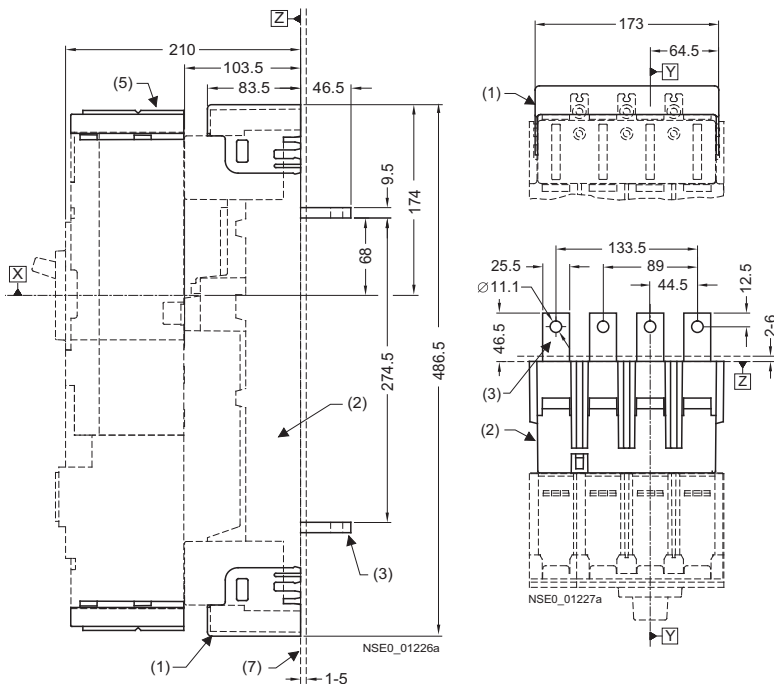

Hole pattern and cut-out for plug-in base with rear flat bar connection

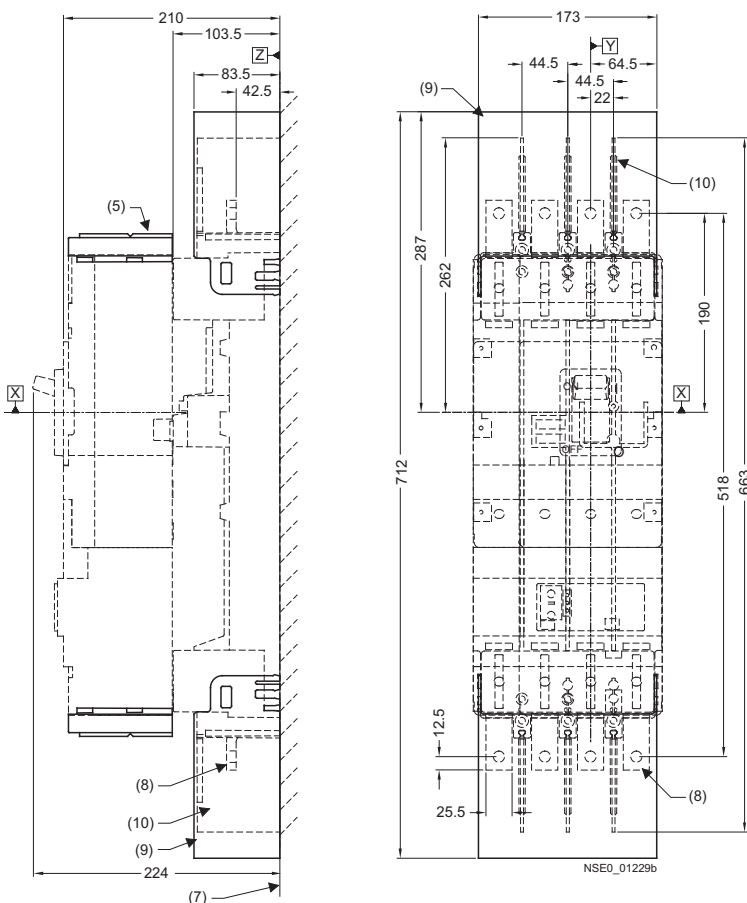
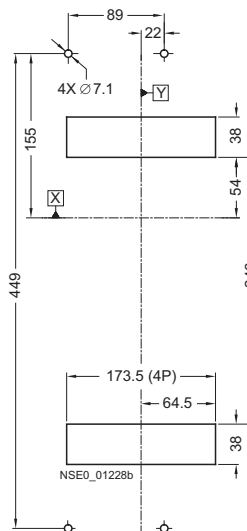

Hole pattern for plug-in base with front connecting bars

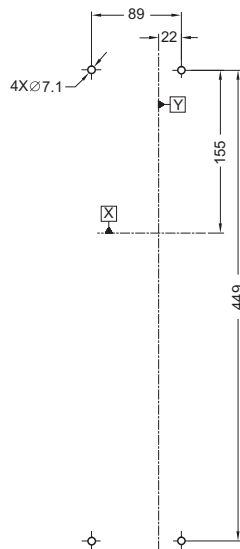

- (1) Plug-in base with terminal covers
- (2) Plug-in base
- (3) Plug-in base with rear flat bar connection
- (5) Terminal covers (standard)
- (7) Installation level
- (8) Plug-in base with front connecting bars
- (9) Plug-in base with terminal covers on the front
- (10) Phase barrier

3VL Molded Case Circuit Breakers

3VL Molded Case Circuit Breakers up to 1600 A

Project planning aids

VL400 (3VL4) with RCD module, 3- and 4-pole, up to 400 A

Plug-in bases and accessories

SENTRON VL400 (3VL4) circuit breakers with RCD module, withdrawable, with motorized operating mechanism with stored-energy mechanism (connected position)

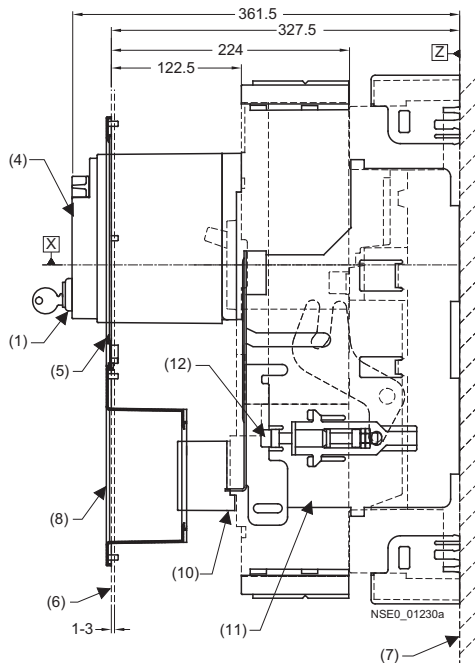

SENTRON VL400 (3VL4) circuit breakers with RCD module, withdrawable, with motorized operating mechanism with stored-energy mechanism (disconnected position)

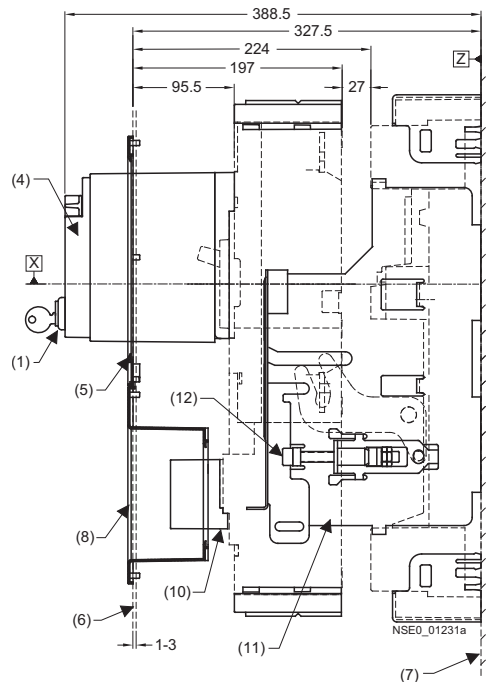

SENTRON VL400 (3VL4) circuit breakers with RCD module, plug-in, with front-operated rotary operating mechanism (connected position)

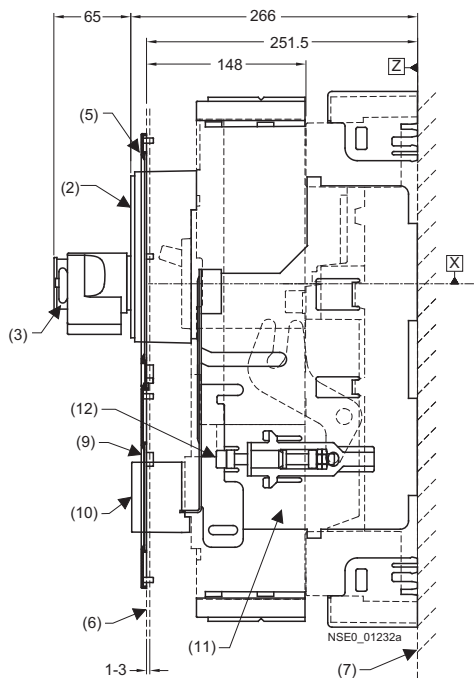

SENTRON VL400 (3VL4) circuit breakers with RCD module, plug-in, with front-operated rotary operating mechanism (disconnected position)

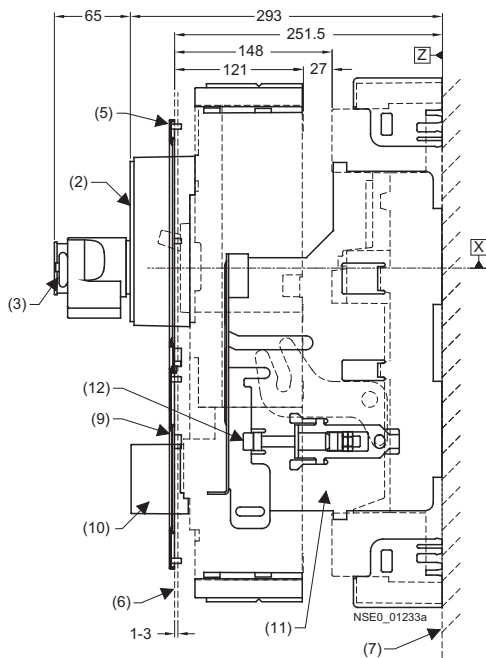

- | | |
|---|---|
| (1) Safety lock | (7) Installation level |
| (2) Front-operated rotary operating mechanism | (8) Masking frame for door cut-out (for circuit breaker with RCD module, motorized operating mechanism) |
| (3) Padlock | (9) Masking frame for door cut-out (for circuit breaker with RCD module, toggle lever/rotary operating mechanism) |
| (4) Motorized operating mechanism with stored-energy mechanism | (10) RCD extended escutcheon |
| (5) Masking frame for door cut-out (for circuit breaker with operating mechanism) | (11) Locking device for racking mechanism |
| (6) Outside surface of cabinet door | (12) Racking mechanism |

3VL Molded Case Circuit Breakers

3VL Molded Case Circuit Breakers up to 1600 A

Project planning aids

VL400 (3VL4) with RCD module, 3- and 4-pole, up to 400 A

Plug-in bases and accessories

SENTRON VL400 (3VL4) circuit breakers with RCD module, withdrawable, with extended escutcheon (connected position)

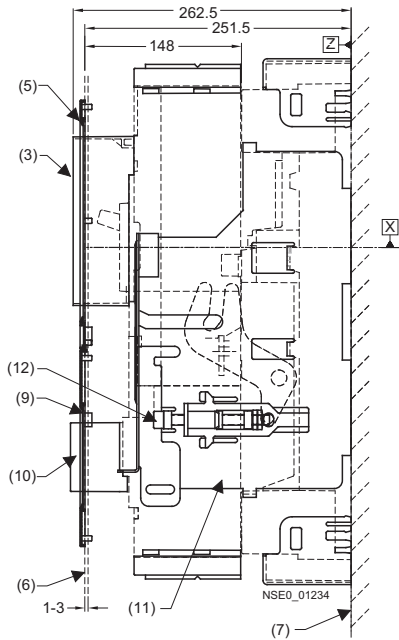

SENTRON VL400 (3VL4) circuit breakers with RCD module, withdrawable, with extended escutcheon (disconnected position)

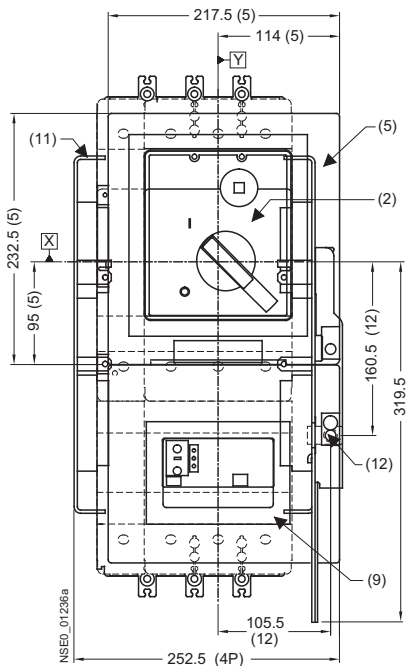
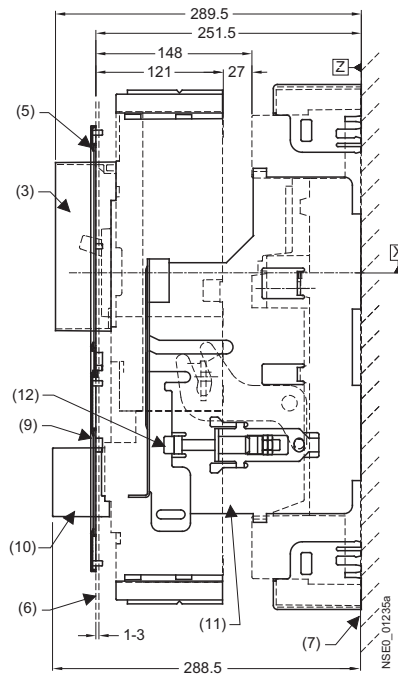

- (1) Safety lock
- (2) Front-operated rotary operating mechanism
- (3) Circuit breaker extended escutcheon
- (4) Motorized operating mechanism with stored-energy mechanism
- (5) Masking frame for door cut-out (for circuit breaker with operating mechanism)
- (6) Outside surface of cabinet door
- (7) Installation level
- (8) Masking frame for door cut-out (for circuit breaker with RCD module, motorized operating mechanism)
- (9) Masking frame for door cut-out (for circuit breaker with RCD module, toggle lever/rotary operating mechanism)
- (10) RCD extended escutcheon
- (11) Locking device for racking mechanism
- (12) Racking mechanism

3VL Molded Case Circuit Breakers

3VL Molded Case Circuit Breakers up to 1600 A

Project planning aids

8UC door-coupling rotary operating mechanisms

8UC71 and 8UC72 door-coupling rotary operating mechanisms, sizes 1 and 2

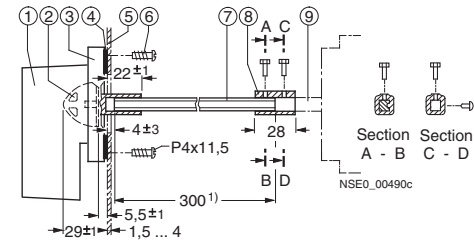

With extension shaft

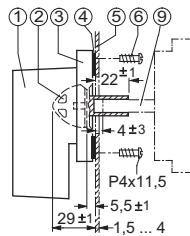

Without extension shaft

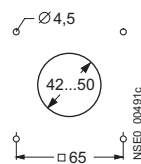

Door cut-out with mounting holes

- ① Selector switch
- ② Coupling driver
- ③ Masking plate
- ④ Seal
- ⑤ Door
- ⑥ Fixing screw, 4 units
- ⑦ Extension shaft
- ⑧ Shaft coupling
- ⑨ Actuating shaft of the control

8UC73 door-coupling rotary operating mechanisms, size 3

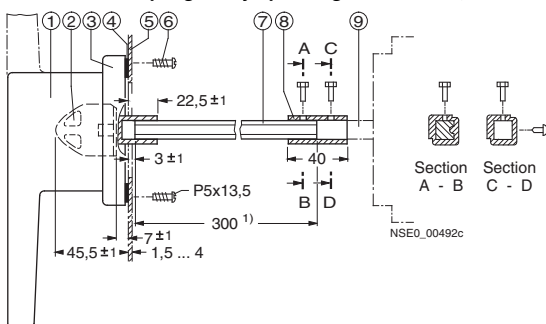

With extension shaft

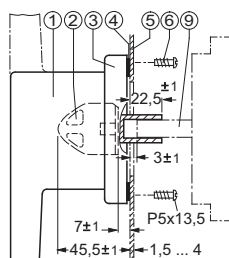

Without extension shaft

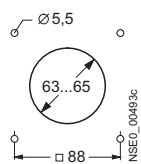

Door cut-out with mounting holes

- ① Handle or twin handle
- ② Coupling driver
- ③ Masking plate
- ④ Seal
- ⑤ Door
- ⑥ Fixing screw, 4 units
- ⑦ Extension shaft
- ⑧ Shaft coupling
- ⑨ Actuating shaft of the control

1) Length of extension shaft can be cut to fit mounting depth. Extension shaft also available in 600 mm length.

8UC60 coupling driver

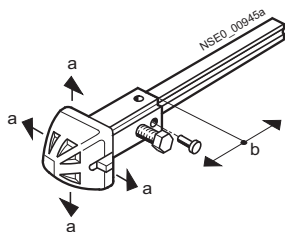

Coupling drivers	a	b	Shaft length
With tolerance compensation	+5	±5	x
Without tolerance compensation	+1.5	±2.5	x+23.5

Size 1

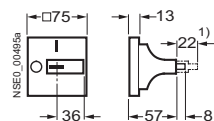

Size 2

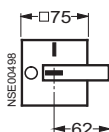

Size 3

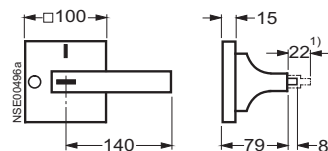

Handles with masking plate, sizes 1 to 3

1) Padlock feature of handle pulled out.

3VL Molded Case Circuit Breakers

3VL Molded Case Circuit Breakers up to 1600 A

Project planning aids

4NC current transformers for measuring purposes

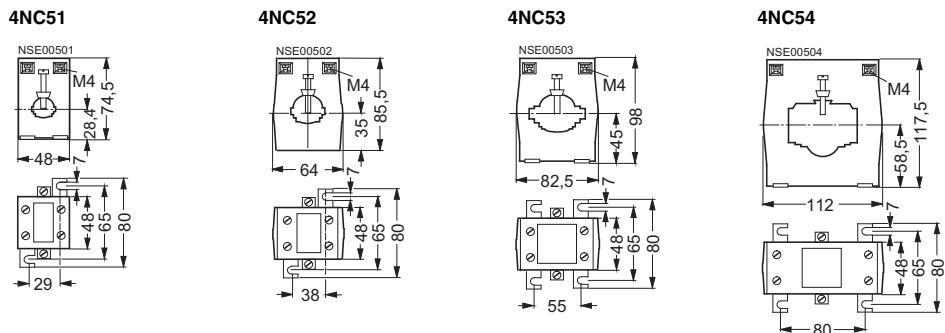

Window openings

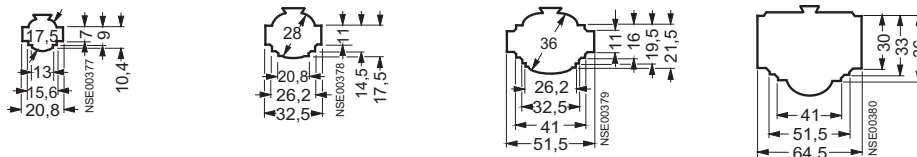

- For busbars	Number	1		2		1		2		1			2			3																		
		Width × Thickness mm			max. mm			max. mm			max. mm			max. mm			max. mm																	
		12 × 5	12 × 10	20 × 5	20 × 10	25 × 5	25 × 5	25 × 5	25 × 5	40 × 10	40 × 5	40 × 5	40 × 10	40 × 5	40 × 5	40 × 5	40 × 10	40 × 5	40 × 5	40 × 10	40 × 5	40 × 5	40 × 10	40 × 5	40 × 5	40 × 10	40 × 5	40 × 5	40 × 10	40 × 5	40 × 5	40 × 10		
		17.5 ∅		28 ∅		36 ∅		36 ∅		45 ∅		45 ∅		45 ∅		45 ∅		45 ∅		45 ∅		45 ∅		45 ∅		45 ∅		45 ∅		45 ∅		45 ∅		45 ∅

COM20/COM21 (communication module for SENTRON 3VL)

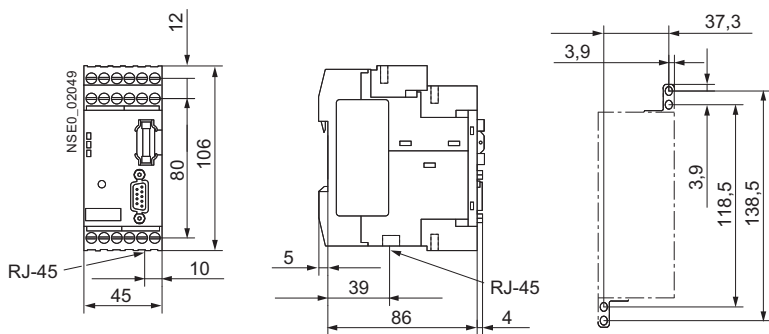

COM10/COM11 (communication module for SENTRON 3VL)

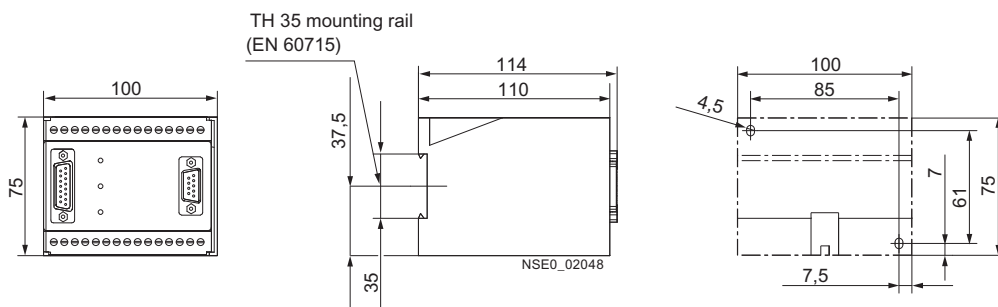

3VL Molded Case Circuit Breakers

3VL Molded Case Circuit Breakers up to 1600 A

Project planning aids

Schematics

The graphical symbols used in the circuit diagrams provide information about the type, circuit and mode of operation of the devices according to DIN 40713, but contain no information about the design.

As it is not possible to show all of the potential combinations here, it may be necessary to alter the schematics accordingly for different versions.

The purpose of these circuit diagrams is merely to help improve the understanding of the way in which the devices function.

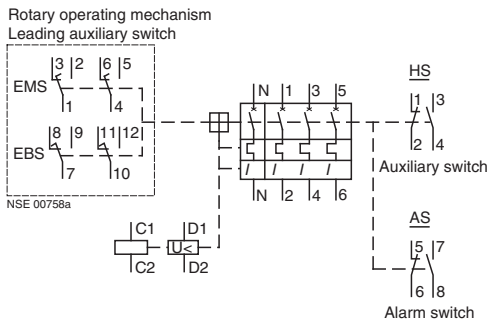

Connection diagram for SENTRON VL160X (3VL1) to VL630 (3VL5), 3- and 4-pole circuit breakers for system protection with thermal-magnetic overcurrent releases

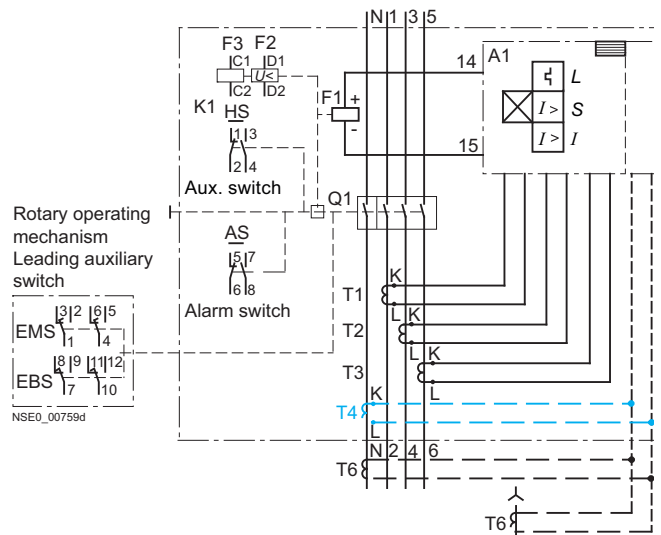

Internal circuit diagram for SENTRON VL160 (3VL2) and VL250 (3VL3), 3- and 4-pole circuit breakers for system protection and motor protection with solid-state releases

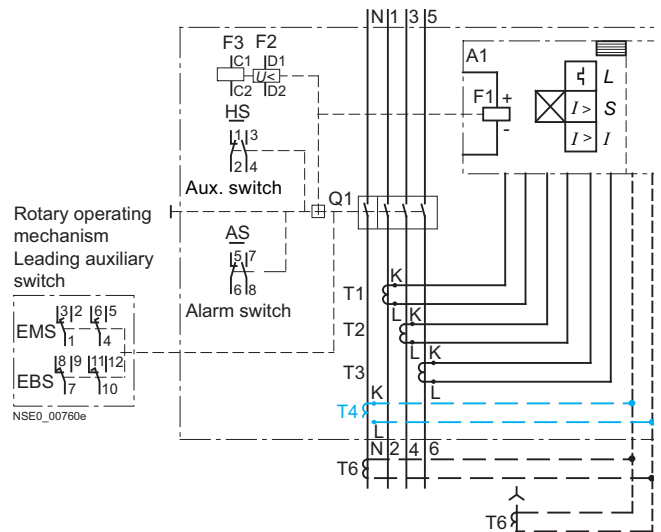

Internal circuit diagram for SENTRON VL400 (3VL4) circuit breaker for motor protection and SENTRON VL400 (3VL4) to VL1600 (3VL8), 3- and 4-pole circuit breakers for system protection with solid-state releases

- 4-pole version
- Q1 Main contacts
 - A1 Solid-state release
 - F1 Tripping solenoid for A1
 - F2 Undervoltage releases
 - F3 Shunt release
 - HS Auxiliary switches
 - AS Alarm switch
 - EBS Leading auxiliary switch from ON to OFF (installed in rotary operating mechanism)
 - EMS Leading auxiliary switch from OFF to ON (installed in rotary operating mechanism)
 - T1 ... T6 Current transformers

3VL Molded Case Circuit Breakers

3VL Molded Case Circuit Breakers up to 1600 A

Project planning aids

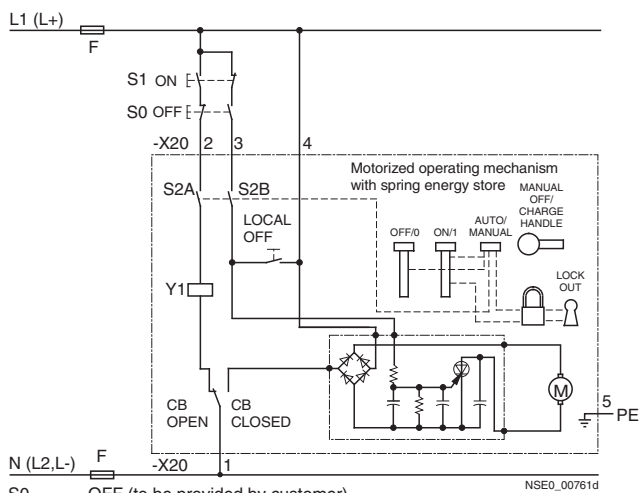

- S0 OFF (to be provided by customer)
- S1 ON (to be provided by customer)
- S2 Selector switch auto/manual
- S4 Interlocking switch
- Y1 Closing solenoid
- F Fuse in control circuit
- S01 Remote control (to be provided by customer)
- K1 Contactor relay (to be provided by customer)

Motorized operating mechanism with stored-energy mechanism for SENTRON VL160X (3VL1) to VL250 (3VL3) circuit breakers without undervoltage release

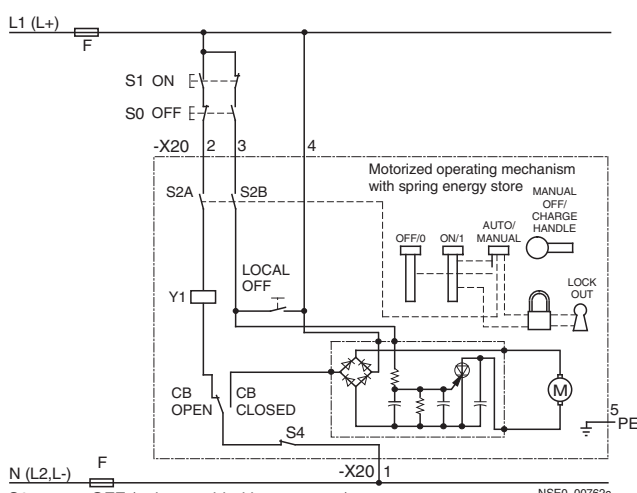

- S0 OFF (to be provided by customer)
- S1 ON (to be provided by customer)
- S2 Selector switch auto/manual
- S4 Interlocking switch
- Y1 Closing solenoid
- F Fuse in control circuit
- S01 Remote control (to be provided by customer)
- K1 Contactor relay (to be provided by customer)

Motorized operating mechanism with stored-energy mechanism for SENTRON VL400 (3VL4) to VL800 (3VL6) circuit breakers without undervoltage release

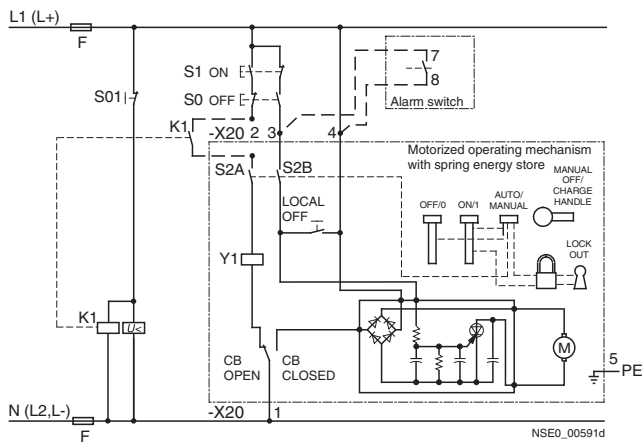

- S0 OFF (to be provided by customer)
- S1 ON (to be provided by customer)
- S2 Selector switch auto/manual
- Y1 Closing solenoid
- F Fuse in control circuit
- S01 Remote control (to be provided by customer)
- K1 Contactor relay (to be provided by customer)

Note: A separate alarm switch (7-8) can be incorporated for automatic charging after a release. Automatic closing of a tripped circuit breaker is not recommended, in order to prevent a switch of the circuit breaker to a fault in the protected circuit.

Motorized operating mechanism with stored-energy mechanism for SENTRON VL160X (3VL1) to VL250 (3VL3) circuit breakers with undervoltage release

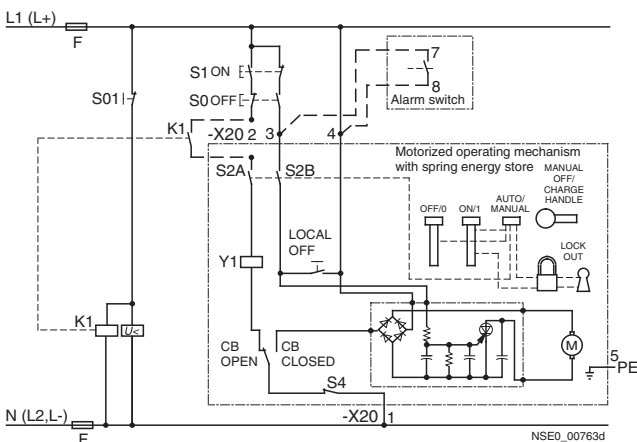

- S0 OFF (to be provided by customer)
- S1 ON (to be provided by customer)
- S2 Selector switch auto/manual
- S4 Interlocking switch
- Y1 Closing solenoid
- F Fuse in control circuit
- S01 Remote control (to be provided by customer)
- K1 Contactor relay (to be provided by customer)

Note: A separate alarm switch (7-8) can be incorporated for automatic charging after a release. Automatic closing of a tripped circuit breaker is not recommended, in order to prevent a switch of the circuit breaker to a fault in the protected circuit.

Motorized operating mechanism with stored-energy mechanism for SENTRON VL400 (3VL4) to VL800 (3VL6) circuit breakers with undervoltage release

3VL Molded Case Circuit Breakers

3VL Molded Case Circuit Breakers up to 1600 A

Project planning aids

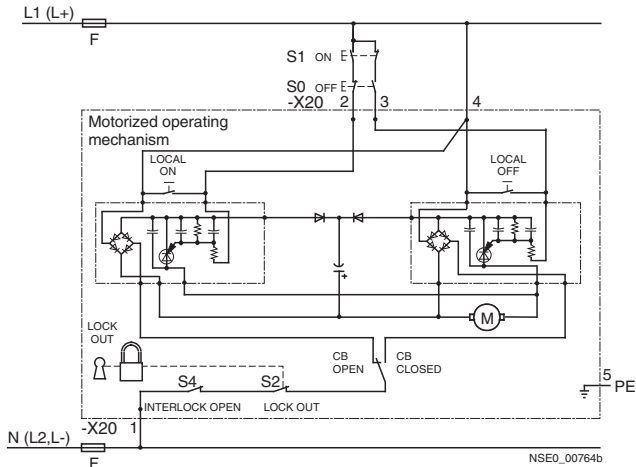

- S0 OFF (to be provided by customer)
- S1 ON (to be provided by customer)
- S2 Lock out
- S4 Interlock open
- F Fuse in control circuit
- S01 Remote control
- K1 Contactor relay

Motorized operating mechanism for SENTRON VL1250 (3VL7) and VL1600 (3VL8) circuit breakers without undervoltage release

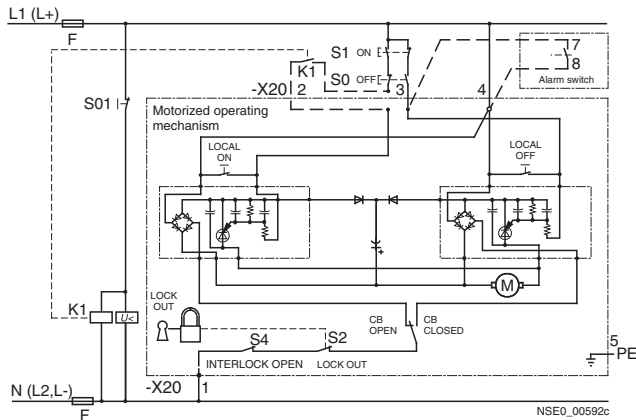

- S0 OFF (to be provided by customer)
- S1 ON (to be provided by customer)
- S2 Lock out
- S4 Interlock open
- F Fuse in control circuit
- S01 Remote control
- K1 Contactor relay

Note: A separate alarm switch (7-8) can be incorporated for automatic charging after a release. Automatic closing of a tripped circuit breaker is not recommended, in order to prevent a switch of the circuit breaker to a fault in the protected circuit.

Motorized operating mechanism for SENTRON VL1250 (3VL7) and VL1600 (3VL8) circuit breakers with undervoltage release

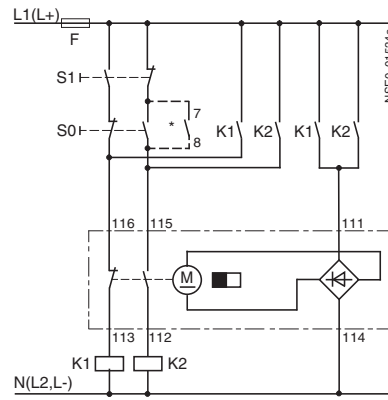

- S0 OFF (to be provided by customer)
- S1 ON (to be provided by customer)
- K1, K2 Contactor relays for motor control
- F Fuse in control circuit

* Alarm switch contact 7-8 causes a switch reset to RESET, i.e. reclosing capability after tripping. Without this contact the result would be a "closing lockout", i.e. reconnection after a trip is not possible until the switch is reset to RESET by the "OFF" command (S0).

Motorized operating mechanism for VL160X (3VL1) to VL250 (3VL3) circuit breakers without undervoltage release

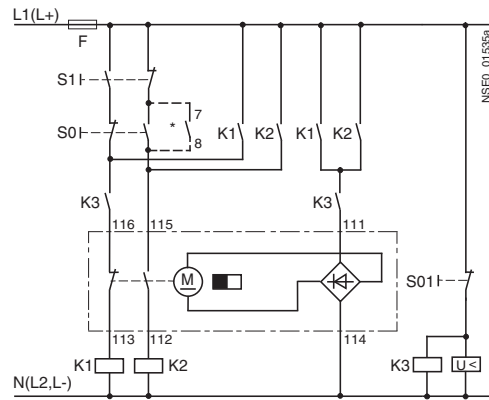

- S0 OFF (to be provided by customer)
- S1 ON (to be provided by customer)
- S01 EMERGENCY-STOP or remote tripping
- K1, K2, K3 Contactor relays for motor control
- F Fuse in control circuit

* Alarm switch contact 7-8 causes a switch reset to RESET, i.e. reclosing capability after tripping. Without this contact the result would be a "closing lockout", i.e. reconnection after a trip is not possible until the switch is reset to RESET by the "OFF" command (S0).

Motorized operating mechanism for VL160X (3VL1) to VL250 (3VL3) circuit breakers with undervoltage release

3VL Molded Case Circuit Breakers

3VL Molded Case Circuit Breakers up to 1600 A

Project planning aids

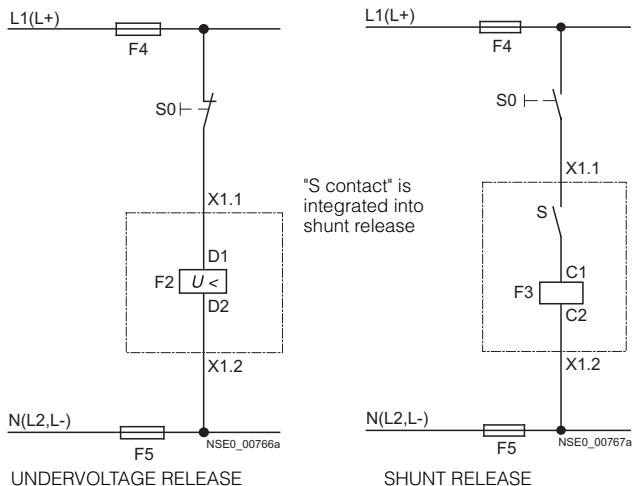

Undervoltage release and shunt release for SENTRON VL160X (3VL1) to VL1600 (3VL8) circuit breakers

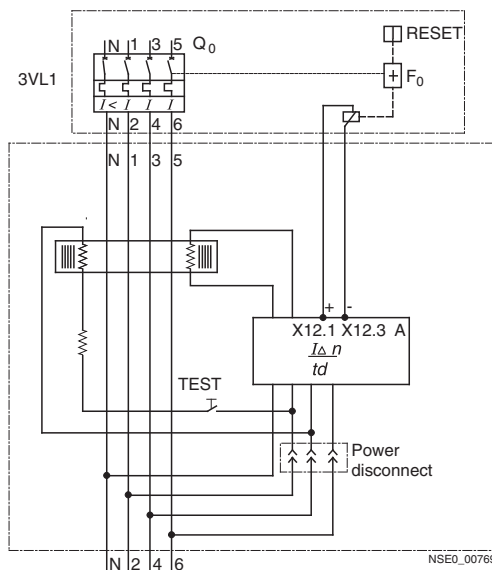

- Q₀ Circuit breaker
- A Solid-state evaluation unit
- F₀ Tripping solenoid with local tripping display and reset
- TEST Test button

SENTRON VL160X (3VL1) 4-pole circuit breaker with RCD module shown. 3-pole version similar, but without N pole.

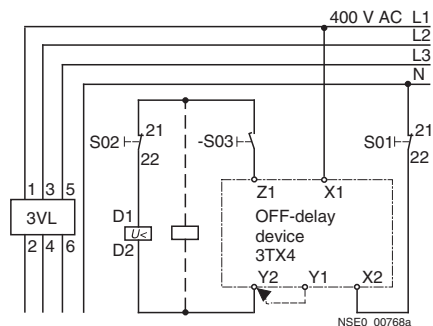

- S01 Delayed tripping
- S02 Instantaneous tripping for EMERGENCY-STOP circuit (if required)
- S03 Early-make auxiliary contact, e.g. 3VL9300-3AS10 "OFF to ON" in the front-operated rotary operating mechanism of the circuit breaker (if required)
- K1 3RH11 contactor relay (if required)

Time-delay device for undervoltage release for SENTRON VL160X (3VL1) to VL1600 (3VL8) circuit breakers

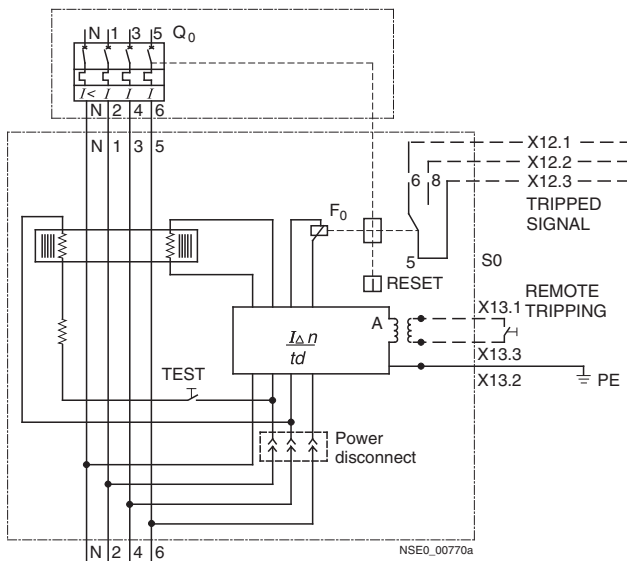

- Q₀ Circuit breaker
- A Solid-state evaluation unit
- F₀ Tripping solenoid with local tripping display and reset
- TEST Test button
- S0 Remote tripping (to be set by customer)

4-pole circuit breaker for SENTRON VL160 (3VL2), VL250 (3VL3) and VL400 (3VL4) circuit breakers with remote trip and RCD alarm switch. 3-pole version similar, but without N pole.

3VL Molded Case Circuit Breakers

3VL Molded Case Circuit Breakers up to 1600 A

Project planning aids

4NC current transformers for measuring purposes

Terminal designation acc. to IEC 60185/VDE 0414-1

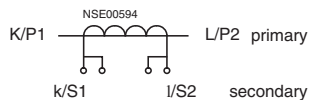

More information

Manual for the SENTRON 3VL circuit breaker

This manual contains additional technical information, covering a product description, mode of operation, electrical wiring system and retrofitting.

The manual and operating instructions are available in PDF format at:

<http://www.siemens.com/lowvoltage/manuals>

SENTRON manual for communication solutions

Free download at

<http://www.siemens.com/lowvoltage/manuals>

See also the chapter "Air Circuit Breakers" under "3WL Air Circuit Breakers/Non-Automatic Air Circuit Breakers up to 6300 A (AC)", "Accessories/Components".

3VF2 Molded Case Circuit Breakers

3VF2 Molded Case Circuit Breakers up to 100 A

General data

Technical specifications

Type		3VF2	
Standards		IEC 60947-2, EN 60947-2	
Max. rated current I_n		A	16 up to 100
Rated insulation voltage U_i			
Main current paths	V AC	415	
Control circuits	V AC	415	
Rated impulse withstand voltage U_{imp}			
Main current paths	kV	6	
Control circuits	kV	4	
Rated operational voltage U_e, 50/60 Hz			
IEC	V AC	Up to 415	
Permissible ambient temperature		°C	-20 to +70
Permissible load			
At various ambient temperatures close to the circuit breaker, related to the rated current of the circuit breaker			Up to 100 A
- Circuit breakers for system protection	At 40 °C %		100
	50 °C %		92
	55 °C %		87
	60 °C %		83
	70 °C %		73
Rated short-circuit breaking capacity		Switching capacity class	A
Rated ultimate short-circuit breaking capacity I_{CU}	Up to 240 V	kA	65
	Up to 415 V	kA	18
Rated service short-circuit breaking capacity I_{CS}	Up to 240 V	kA	33
	Up to 415 V	kA	9
Rated short-circuit making capacity I_{CM}	Up to 240 V	kA	143
	Up to 415 V	kA	36
Main control switch properties acc. to IEC 60947-2 in conjunction with lockable rotary operating mechanisms			Yes
EMERGENCY-STOP switch properties			Yes
Acc. to EN 60204-1			
Mechanical endurance		Operating cycles	10 000
Switching frequency		1/h	120
Conductor cross-sections and connection types for main conductors (copper or aluminum)			
Connection type			Circular conductor terminal
solid or stranded	To 40 A	mm ²	2.5 to 6
	45 to 100 A	mm ²	16 to 50
	125 A	mm ²	70
Conductor cross-sections for control circuits			
With terminal connection or terminal strip, solid		mm ²	0.5 to 2.5
Power loss per circuit breaker			
At max. rated current I_n with 3-phase symmetrical load - System protection		W	16
Permissible mounting positions			
Auxiliary switches			
Conventional thermal current I_{th}		A	6
Rated making capacity		A	15
AC (AC-15)			
- Rated operational voltage	V	240	
- Rated operational current	A	6	
DC current (DC-13)			
- Rated operational voltage	V	125	
- Rated operational current	A	0.5	
Back-up fuse	A	4	
Auxiliary releases			
Shunt release (f-release)			
Response voltage			
- Pick-up (circuit breaker is tripped)			
Power consumption (short time) at:			
AC 50/60 Hz 12-24 V	VA	108	
AC 50/60 Hz 48-60 V	VA	120	
AC 50/60 Hz 48-127 V	VA	162	
12 - 24 V DC	W	14.4	
48 - 60 V DC	W	19.2	
110 - 125 V DC	W	38.4	
220-250 V DC	W	44	
Max. duration of operational voltage			Interrupts automatically
Max. opening time	ms	50	

3VF2 Molded Case Circuit Breakers

3VF2 Molded Case Circuit Breakers up to 100 A

Project planning aids

Dimensional drawings

3VF2 circuit breakers, 3- and 4-pole

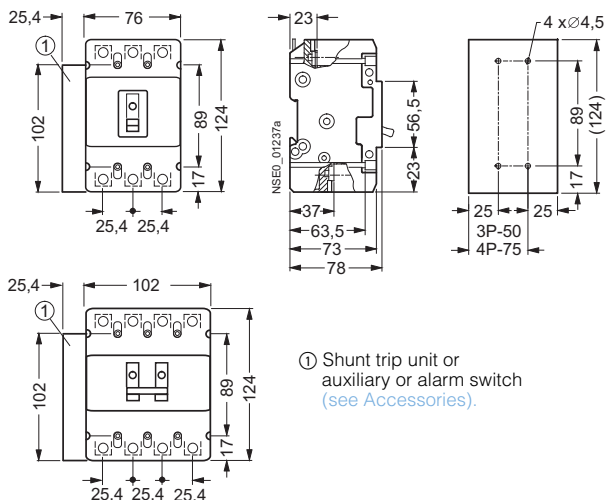

Arcing spaces

Minimum clearances from adjacent grounded parts and from non-insulated live parts at rated voltage. The distance of at least 2 cm between large covers and the arc chute openings should be observed for the 3VF2. Plain conductors and busbars must be insulated within the arcing space.

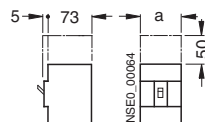

Type	a
3VF2, 3-pole	78
3VF2, 4-pole	101

3VF2

Accessories for 3VF2 circuit breakers, 3- and 4-pole

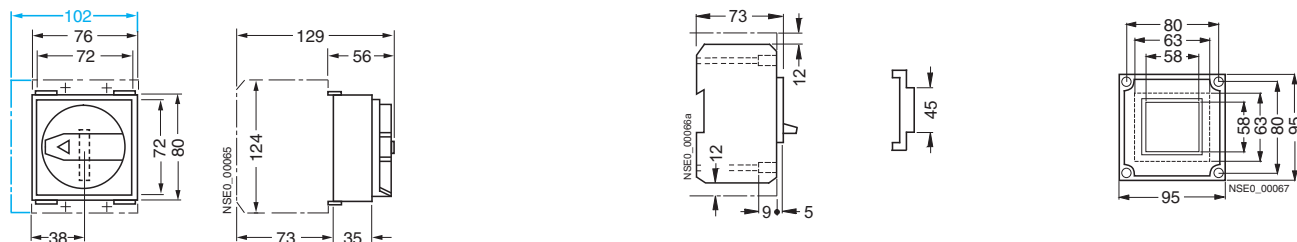

3VF9 223-1.A00 front-operated rotary operating mechanism with knob for 3VF2

3VF9 224-1NB.0 terminal cover for 3VF2

3VF9 220-1CA10 cover with cap dimension 45 mm for 3VF2

3VF9 220-1AA00 cover frame for door cut-out for 3VF2

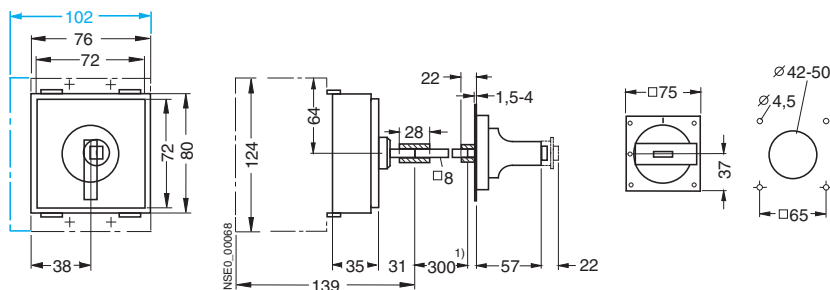

Door-coupling rotary operating mechanism, complete 8UC61 .2-.BD22 (rotary operating mechanism) and 3VF9 223-1JA00 (front-operated rotary operating mechanism with shaft end) for 3VF2

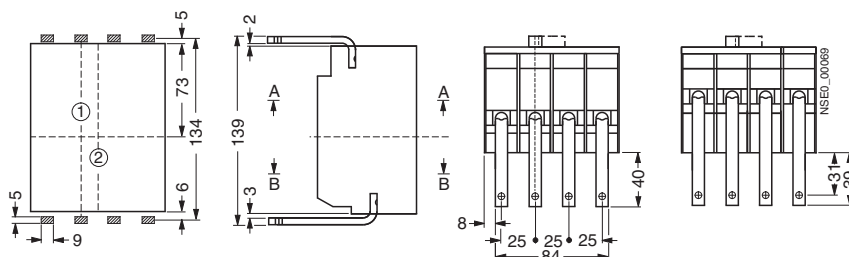

3VF9 224-1LD.0 rear terminal for 3VF2

View A

View B

Center line
 ① 3-pole circuit breaker
 ② 4-pole circuit breaker

1) As-supplied, shorten shaft to suit if necessary. With lengths > 130 mm a support is necessary.

4-pole version

Note: 4-pole circuit breakers always have the 4th pole (N) on the left!

SENTRON Switching and Protection Devices – Switch Disconnectors, 8US Busbar Systems

17



17/2 Introduction

3KA, 3KE, 3LD Switch Disconnectors

3KA, 3KE Switch Disconnectors up to 1000 A

17/5 General data

17/10 Floor mounting

3LD Main and EMERGENCY-STOP Switches up to 125 A

17/12 General data

17/15 Front mounting

17/18 Floor mounting

17/19 Distribution board mounting

17/20 Molded-plastic enclosures

17/21 Accessories

3KL, 3KM, 3NJ6 Switch Disconnectors with Fuses

3KL Switch Disconnectors with Fuses up to 800 A

17/23 General data

17/26 Surface mounting and installation

3KM Switch Disconnectors with Fuses and Isolating Plug Connector up to 400 A

17/28 General data

17/31 For snapping onto busbars

8UC Door-Coupling Rotary Operating Mechanisms

17/34 For 3K switch disconnectors

17/37 Individual parts

17/38 Operating mechanisms for fixed mounting
3NJ6 In-Line Switch Disconnectors with Fuses up to 630 A
3NJ62 switch disconnectors with fuses

17/39 - General data

3NP, 3NJ4, 3NJ5

Fuse Switch Disconnectors

3NP Fuse Switch Disconnectors up to 630 A

17/52 General data

17/58 3NP4 for power distribution

17/62 3NP5 for extended technical requirements

3NJ4, 3NJ5 In-Line Fuse Switch Disconnectors up to 1250 A

17/65 General data

17/69 1-pole switchable

17/70 3-pole switchable

17/71 Accessories

8US Busbar Systems

17/72 General data

40 mm busbar systems

17/73 General data

17/74 Base assemblies

17/75 Infeed and connection components

17/76 Busbar adapters and device holders

17/79 Accessories

60 mm busbar systems

17/80 General data

17/81 Base assemblies up to 630 A

17/84 Base assemblies up to 1600 A

17/85 Infeed and connection components

17/87 Busbar adapters and device holders

17/90 Bus-mounting fuse bases

17/91 Accessories

Switch Disconnectors, 8US Busbar Systems

Introduction

Overview



Type		3LD20	3LD21	3LD22	3LD25	3LD27	3LD28
3LD main and EMERGENCY-STOP switches from 16 A to 125 A							
Rated uninterrupted current I_u							
At 35 °C ambient temperature	A	16	25	32	63	100	125
Rated operational voltage							
U_e	V	690	690	690	690	690	690
AC-3 motor load switches							
Operational switching of individual motors							
• At 220 ... 240 V	kW	3.0	4.0	5.5	11.0	18.5	22.0
• At 380 ... 440 V	kW	5.5	7.5	9.5	18.5	30.0	37.0
• At 660/690 V	kW	5.5	7.5	9.5	15.0	22.0	30.0
AC-23A main control switches, repair switches							
Frequent, but not operational switching of single motors							
• At 220 ... 240 V	kW	4.0	5.0	6.0	11.0	18.5	22.0
• At 380 ... 440 V	kW	7.5	9.5	11.5	22.0	37.0	45.0
• At 660/690 V	kW	7.5	9.5	11.5	18.5	30.0	37.0
Switch versions							
Front mounting							
• Central		✓	✓	✓	✓	--	--
• Four-hole		✓	✓	✓	✓	✓	✓
Floor mounting							
• Central		✓	✓	✓	✓	--	--
• Four-hole		✓	✓	✓	✓	✓	✓
Distribution board mounting							
		✓	✓	✓	✓	✓	✓
Molded-plastic enclosures							
• Metric screwed glands		✓	✓	✓	✓	✓	✓
Switch accessories							
4th pole (N conductor) (leading switch-on, delayed switch-off)		✓	✓	✓	✓	✓	✓
N terminals		✓	✓	✓	✓	✓	✓
PE/ground terminals		✓	✓	✓	✓	✓	✓
Auxiliary contacts							
• 1 NO + 1 NC		✓	✓	✓	✓	✓	✓

✓ Available

-- Not available



Type		3NP	3K	3NJ4	3NJ6
SENTRON					
Rated uninterrupted current I_U					
At 35 °C ambient temperature	A	160 to 630	63 to 1000	160 to 1250	160 to 690
Rated operational voltage					
U_e	V	690	690	690	690
AC-21					
At 400 V		✓	✓	✓	✓
At 500 V		✓	✓	✓	✓
At 690 V		✓	✓	✓	✓
AC-22					
At 400 V		✓	✓	✓	✓
At 500 V		✓	✓	✓	✓
At 690 V		✓	✓	✓	✓
AC-23					
At 400 V		✓	✓	--	✓
At 500 V		--	✓	--	✓
At 690 V		--	✓	--	✓
Switch versions					
Front mounting		--	✓	--	--
Floor mounting		✓	✓	--	--
Busbars					
• 40 mm		✓	--	--	--
• 60 mm		✓	✓	--	--
• 185 mm		--	--	✓	✓
Molded-plastic enclosures		✓	✓	--	--
Switch accessories					
Auxiliary contacts					
• 1 NO + 1 NC		--	✓	--	✓
• 1 CO		✓	✓	✓	--
Fuse monitoring					
• With circuit breakers		✓	✓	✓	--
• With electronics		✓	✓	✓	--
Current transformers		--	--	✓	✓

✓ Available

-- Not available

Switch Disconnectors, 8US Busbar Systems

Introduction



Type	40 mm busbar systems	60 mm busbar systems
8US busbar systems		
Adapters for SIRIUS size S00/S0		
Motor starter protectors/circuit breakers	✓	✓
Motor starter protectors/circuit breakers + lateral auxiliary switch	✓	✓
Contactors + overload relay	✓	✓
Direct-on-line start load feeders	✓	✓
Reversing feeders	✓	✓
Adapters for SIRIUS size S2		
Motor starter protectors/circuit breakers	✓	✓
Motor starter protectors/circuit breakers + lateral auxiliary switch	✓	✓
Contactors + overload relay	✓	✓
Direct-on-line start load feeders	✓	✓
Reversing feeders	✓	✓
Adapters for SIRIUS size S3		
Motor starter protectors/circuit breakers	✓	✓
Adapters for 3VF circuit breakers		
3VF3	✓	✓
3VF4	--	✓
3VF5	--	✓
Adapters for 3VL circuit breakers		
3VL1	✓	✓
3VL2	✓	✓
3VL3	--	✓
3VL4	--	✓
Adapters for 3KA switch disconnectors		
3KA52	--	✓
3KA53	--	✓
3KA55	--	✓
3KA57	--	✓
3KA58	--	✓
Adapters for 3NP fuse switch disconnectors		
3NP50 60	--	✓
3NP52	--	✓
3NP53	--	✓
3NP54	--	✓

✓ Standard

-- Not available

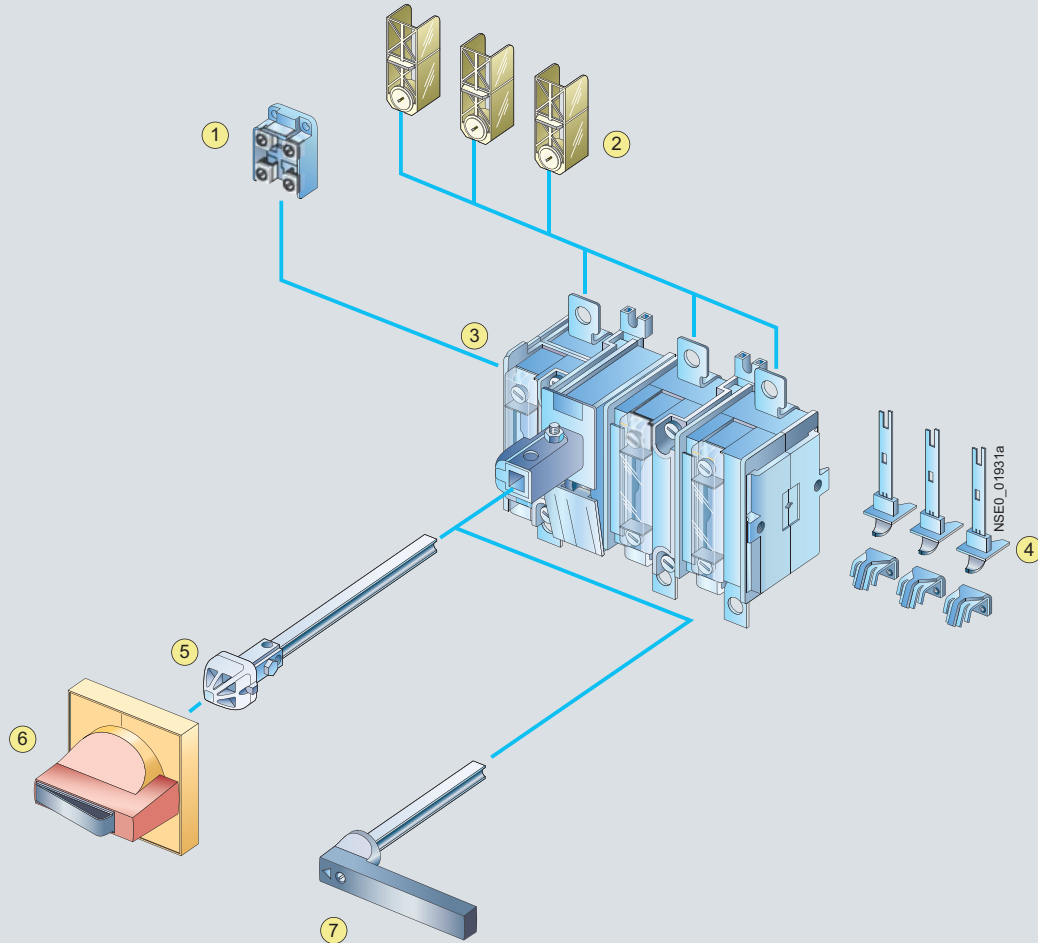
Overview

- ① Auxiliary switch (3SB for 3KA; 3KX for 3KE)
- ② IP20 terminal cover (Operator side)
- ③ 3K switch disconnector
- ④ Arcing contacts (only for 3KE)
- ⑤ Extension shaft
- ⑥ 8UC7 door-coupling rotary operating mechanism in standard version (ti-grey) or EMERGENCY-STOP version (red/yellow).
- ⑦ 8UC9 knob for fixed mounting in standard version (black) or EMERGENCY-STOP version (red/yellow).

All components from the switch to the actuator are provided with non-interchangeability features.

Design

For the 3KA switch disconnectors, complete kits for standard and EMERGENCY-STOP application are available for installation in the side and rear panels of control cabinets.

A changeover operating mechanism is available for the use of 2 switch disconnectors in the 3KE series as load changeover switches.

An operating linkage permits simultaneous switching of two 3KE switch disconnectors with identical or different rated operational currents.

Identical accessories for 3KA switch disconnectors and for 3KL and 3KM switch disconnectors with fuses simplify stock keeping.

3KA, 3KE, 3LD Switch Disconnectors

3KA, 3KE Switch Disconnectors up to 1000 A

General data

Technical specifications

Permissible mounting positions

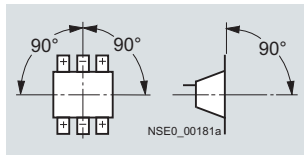

3KE

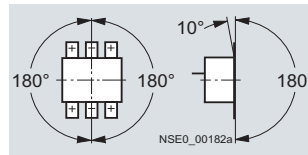

3KA

Standards		IEC 60947-1, IEC 60947-3						
		3KA50	3KA51	3KA52 ¹⁾	3KA53 ¹⁾	3KA55 ¹⁾	3KA57 ¹⁾	3KA58 ¹⁾
Type								
Rated uninterrupted current I_U	A	63	80	125	160	250	400	630 ³⁾
Conventional free-air thermal current $I_{th}^{2)}$	A	63	80	125	160	250	400	630 ³⁾
Rated insulation voltage U_i	V	690	690	1000	1000	1000	1000	1000
Rated impulse voltage U_{imp}	kV	6	6	8	8	8	8	8
Rated operational voltage U_e								
AC 50 Hz/60 Hz	V	690						
DC	V	440 (3 conducting paths series-connected)						
	V	220 (2 conducting paths series-connected)						
	V	110 (1 conducting path)						
Rated short-circuit making capacity I_{cm} with upstream fuses⁴⁾	kA (peak value)	220	220	220	220	176	176	105
At AC 50 Hz/60 Hz 690 V								
Rated conditional short-circuit current with upstream fuses⁴⁾	kA (rms value)	100	100	100	100	80	80	50
At AC 50 Hz/60 Hz 690 V								
Max. rated current I_n of the fuses	A	63	80	160	160	400	400	630
Permissible let-through current of the fuses	kA	8	10	17	17	30 ⁵⁾	30 ⁵⁾	40 ⁵⁾
Maximum permissible let-through I^2t value	kA ² s	55	55	223	223	1000	1000	2600
Permissible let-through current of an upstream circuit breaker	kA (peak value)	7	8	8	15	25	25	32
At AC 50 Hz/60 Hz 690 V								
Rated short-circuit making capacity without fuses	kA (peak value)	7	7	7	9	20	25	35
At AC 50 Hz/60 Hz 690 V								
Switching capacity (infeed from the top or bottom)								
At 400 V AC								
Breaking current I_c (p.f. = 0.35)	A (rms value)	500	650	1000	1280	2000	3200	5040
Rated operational current I_e at AC-21A, AC-22A, AC-23A	A	63	80	125	160	250	400	630 ⁶⁾
Motor switching capacity AC-23A	kW	30	40	65	80	132	200	350
At 500 V AC								
Breaking current I_c (p.f. = 0.35)	A (rms value)	500	640	1000	1280	2000	3200	3200
Rated operational current I_e at AC-21A, AC-22A	A	63	80	125	160	250	400	630
AC-23A	A	63	80	125	160	250	400	400
Motor switching capacity AC-23A	kW	40	50	90	110	185	280	280
At 690 V AC								
Breaking current I_c (p.f. = 0.35)	A (rms value)	500	500	1000	1280	2000	3200	3200
Rated operational current I_e at AC-21A, AC-22A	A	63	80	125	160	250	400	630
AC-23A	A	63	63	125	160	250	400	400
Motor switching capacity AC-23A	kW	50	50	110	150	220	375	375
At 440 V DC (3 conducting paths series-connected) ⁷⁾								
Breaking current I_c ($L/R = 15$ ms)	A	250	260	500	640	1000 ⁸⁾	1600	1600
Rated operational current I_e at DC-23A	A	63	63	125	160	250 ⁹⁾	400	400
Rated short-time current I_{cw} (1 s current)	kA (rms value)	2.5	2.5	3.2	3.2	8	11	15
Permissible load								
Depending on the ambient temperature for open-type installation in control panels (e. g. 8NA1) in control cubicles or control racks at								
35 °C	A	63	80	125	160	250	400	630
40 °C	A	63	80	125	160	250	400	620
45 °C	A	63	80	125	160	250	400	600
50 °C	A	63	80	125	160	250	400	580
55 °C	A	63	80	125	160	250	400	560
60 °C	A	63	80	125	160	250	400	550

3KA, 3KE, 3LD Switch Disconnectors

3KA, 3KE Switch Disconnectors up to 1000 A

General data

Standards		IEC 60947-1, IEC 60947-3						
Type		3KA50	3KA51	3KA52 ¹⁾	3KA53 ¹⁾	3KA55 ¹⁾	3KA57 ¹⁾	3KA58 ¹⁾
Permissible ambient temperature	°C	-25 ... +55 for operation ³⁾						
	°C	-50 ... +80 when stored						
Mechanical endurance	Operating cycles	15 000	15 000	15 000	15 000	12 000	12 000	12 000
Required operating torque	Nm	3	3	7.5	7.5	16	16	16
Degree of protection		IP00/IP20 (from the operator side, with busbar and terminal covers)						
Power loss of the switch disconnector at I_{th}	W	7	12	22	22	33	72	170
Main conductor connections								
Busbar systems, max. dimensions (w x t)	mm x mm	25 x 9	25 x 9	45 x 10	45 x 10	40 x 12	40 x 12	40 x 15
Cable lug, max. conductor cross-section (stranded)	mm ²	35	35	70	120	150	2 x 150 or 1 x 240	2 x 240
Tightening torque	Nm	6 ... 7.5	6 ... 7.5	7 ... 10	18 ... 22	35 ... 45	35 ... 45	35 ... 45
Terminal screws		M6	M6	M6	M8	M10	M10	M10
Protective conductor connections								
Flat bars	mm x mm	--	--	--	--	20 x 2.5	20 x 2.5	20 x 2.5
Cable lug, max. conductor cross-section (stranded)	mm ²	--	--	--	--	70	120	120
Auxiliary switch 1 NO + 1 NC (accessories)								
Max. number to be plugged		1	1	2	2	2	2	2
Rated operational current I_e at AC 50 Hz/60 Hz								
$I_e/AC-12$	A	10						
$I_e/AC-15$ at $U_e = 220 V/230 V$	A	6						
$I_e/AC-15$ at $U_e = 380 V/400 V$	A	4						
$I_e/AC-15$ at $U_e = 500 V$	A	2.5						
$I_e/AC-15$ at $U_e = 690 V$	A	21.2						
Rated operational current I_e at DC								
$I_e/DC-13$ at $U_e = 24 V$	A	10						
$I_e/DC-13$ at $U_e = 48 V$	A	4						
$I_e/DC-13$ at $U_e = 110 V$	A	1.2						
$I_e/DC-13$ at $U_e = 220 V$	A	0.4						
$I_e/DC-13$ at $U_e = 440 V$	A	0.2						
Connection								
Solid	mm ²	2 x (1 ... 2.5)						
Finely stranded with end sleeve	mm ²	2 x (0.5 ... 1.5)						
Weight								
Complete version	kg	1.450	1.450	2.400	2.400	5.400	5.500	6.100
Basic version	kg	0.950	0.950	1.900	1.900	4.500	4.600	5.200

- 1) Technical specifications for approval on request.
- 2) Configuring note: max. permissible operating temperature at connections 100 °C.
- 3) With 3KA58 for operation -25 °C ... +35 °C, 570 A at 55 °C.
- 4) Only with 3NA38, 3NA32 or 3ND18, 3ND12 fuses (otherwise only 105 kA/50 kA).
- 5) 3ND1 switchgear protection fuse.
- 6) AC-23B.
- 7) Or 220 V DC (L1 and L3 series-connected) or 110 V DC (one conducting path) at DC-23A.
- 8) At 440 V L/R = 4 ms, at 220 V L/R = 15 ms.
- 9) At 440 V DC-22A, at 220 V DC-23A.

3KA, 3KE, 3LD Switch Disconnectors

3KA, 3KE Switch Disconnectors up to 1000 A

General data

Standards	IEC 60947-1, IEC 60947-3, VDE 0660 Part 107				
	Type	3KE42	3KE43	3KE44	3KE45
Rated uninterrupted current I_u	A	250	400	630	1000
Rated insulation voltage U_i	V	1000 AC, 1200 DC			
Rated impulse voltage U_{imp}	kV	8	8	8	8
Rated operational voltage U_e					
AC 50 Hz/60 Hz	V	690			
DC	V	440 (3 conducting paths series-connected)			
	V	220 (2 conducting paths series-connected)			
Rated short-circuit making capacity I_{cm} At 50 Hz/60 Hz 690 V AC	kA (peak value)	35	35	60	60
Rated short-circuit making capacity with upstream fuses At 50 Hz/60 Hz 690 V AC	kA (peak value)	105	105	105	84
Rated conditional short-circuit current with upstream fuses At 50 Hz/60 Hz 690 V AC	A (rms value)	50	50	50	40
Maximum permissible let-through I^2t value	kA ² s	2150	2150	5400	19000
Permissible let-through current of an upstream circuit breaker At 50 Hz/60 Hz 690 V AC	kA (peak value)	35	35	60	60
Max. rated current I_n of the fuses	A	400	400	630	1000
Permissible let-through current of the fuses	kA (peak value)	38	38	60	75
Switching capacity (infeed from the top or bottom)					
At 400 V AC Breaking current I_c (p.f. = 0.35)	A (rms value)	1000	1000	2520	2520
Rated operational current I_e at AC-21A	A	250	400	630	1000
AC-22A	A	250	330	630	800
AC-23A	A	125	125	315	315
At 500 V AC Breaking current I_c (p.f. = 0.35)	A (rms value)	1000	1000	2520	2520
Rated operational current I_e at AC-21A	A	250	400	630	1000
AC-22A	A	250	330	630	800
AC-23A	A	125	125	315	315
At 690 V AC Breaking current I_c (p.f. = 0.35)	A (rms value)	1000	1000	2520	2520
Rated operational current I_e at AC-21A	A	250	400	630	1000
AC-22A	A	250	330	630	800
AC-23A	A	125	125	315	315
At 440 V DC (3 conducting paths series-connected) Breaking current I_c (L/R = 5 ms)	A	1000	1000	2520	2520
Rated operational current I_e at DC-21A	A	250	400	630	1000
DC-22A	A	250	250	630	630
Rated short-time current I_{cw} (1 s current)	A (rms value)	12.5	12.5	21	21
Permissible load Depending on the ambient temperature for open-type installation in control panels (e. g. 8NA1) in control cubicles or control racks at					
35 °C	A	250	400	630	1000
40 °C	A	250	400	630	960
45 °C	A	250	400	630	930
50 °C	A	250	400	630	890
60 °C	A	240	380	600	810
For enclosed installation, e. g. in 8HP systems		See Catalog "8HP System", Order No. E20001-8ZX1012-0HP54-5AB1			
Permissible ambient temperature	°C	-25 ... +55 for operation			
	°C	-50 ... +80 when stored			
Mechanical endurance	Operat- ing cycles	10 000			
Degree of protection		IP00			
Required operating torque	Nm	15	15	24	24

3KA, 3KE, 3LD Switch Disconnectors

3KA, 3KE Switch Disconnectors up to 1000 A

General data

Standards		IEC 60947-1, IEC 60947-3, VDE 0660 Part 107			
		3KE42	3KE43	3KE44	3KE45
Type					
Required operating torque for changeover operating mechanism					
With interruption	Nm	20	20	30	30
Without interruption	Nm	35	35	55	55
Power loss of the switch disconnector at I_{th}		15	33	78	180
Main conductor connections					
Busbar systems, max. dimensions (w x t)	mm x mm	25 x 10	25 x 10	2 x 40 x 10	2 x 40 x 10
Cable lug, max. conductor cross-section (stranded)	mm ²	2 x 150	2 x 150, 1 x 240	2 x 240	2 x 240
Auxiliary switch 1 NO + 1 NC (accessories)					
Rated insulation voltage U_i	V	500			
Rated operational current I_e (same potential at contacts) at AC 50 Hz/60 Hz					
$I_e/AC-1$ at $U_e = 500$ V	A	10			
$I_e/AC-11$ at $U_e = 230$ V	A	6			
Rated operational current I_e (same potential at contacts) at DC					
$I_e/DC-11$ at $U_e = 24$ V	A	10			
$I_e/DC-11$ at $U_e = 220$ V	A	0.4			
Connection					
Solid	mm ²	2 x 2.5			
Finely stranded with end sleeve	mm ²	2 x 1.5			
Short-circuit protection (tested as per DIN VDE 0660 with 1000 A)		6 A TDz, 10 A Dz or 10 A G-type m.c.b.			

Schematics

Internal circuit diagram for 3KA

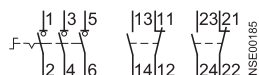

(for 3KA50 and 3KA51, only one auxiliary switch possible; 4th pole is possible as main contact)

Internal circuit diagram for 3KE

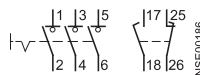

Internal circuit diagram for 3KA and 3KE

(auxiliary switch not included in scope of supply)
Use for DC voltage at DC-23A 440 V

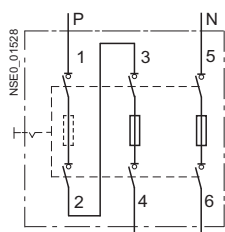

Circuit diagram for changeover switch with interruption

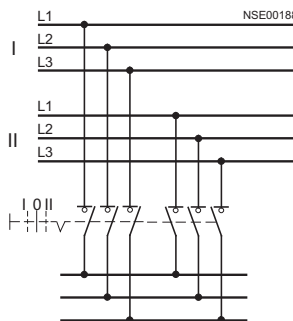

3KA, 3KE, 3LD Switch Disconnectors

3KA, 3KE Switch Disconnectors up to 1000 A

Floor mounting

Dimensional drawings

3KA50, 63 A, 3KA51, 80 A, 3-pole
3KA50 and 3KA51: dimensional drawing for 4-pole version
 corresponds to dimensional drawing for 3KA52
 without shaft, without operating mechanism

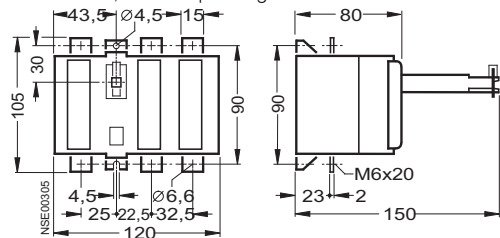

3KA52, 125 A
3KA53, 160 A
3KA50, 3KA51, 4-pole
 without shaft, without operating mechanism

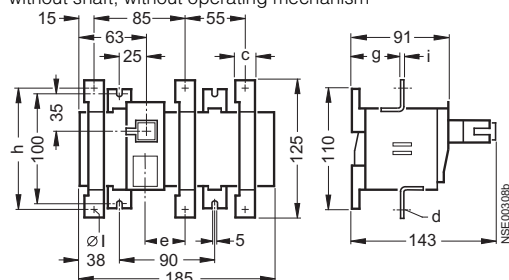

4th pole 3KX3 523-0AA
 for 3KA53, 3KA52

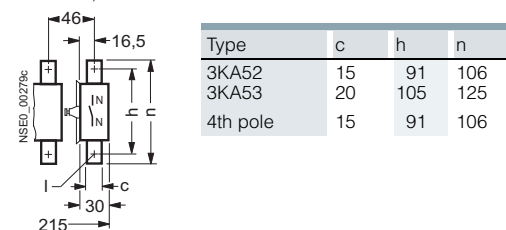

3KA55, 250 A, 3KA57, 400 A
 without shaft, without operating mechanism

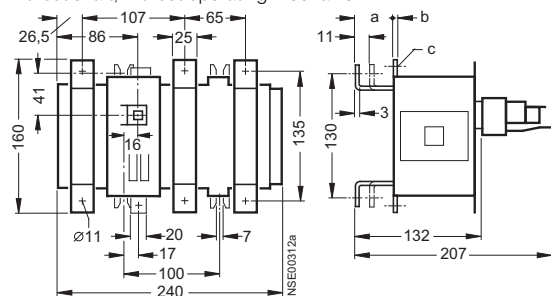

3KA58, 630 A
 without shaft, without operating mechanism

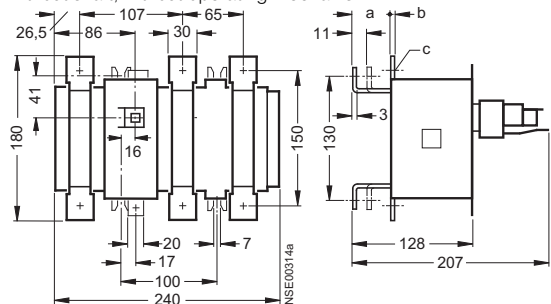

3KA50, 63 A, 3KA51, 80 A, 3-pole
3KA50 and 3KA51: dimensional drawing for 4-pole version
 corresponds to dimensional drawing for 3KA52
 with shaft and 8UC7 operating mechanism

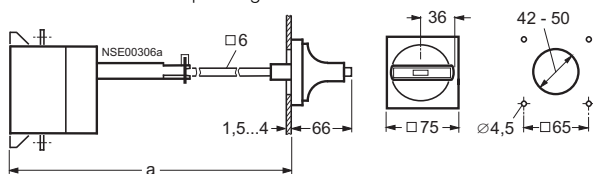

3KA50, 3KA51

Shaft (profile) engaged length:	Shaft length
min. 70 mm	300; unchanged shaft from 8UC71
max. 150 mm	175 ₈₀ ; shortened shaft from 8UC71
	≥ 175 ... ≤ 380 a ₈₀

3KA52, 125 A
3KA53, 160 A
3KA50, 3KA51, 4-pole
 with shaft and 8UC7 operating mechanism

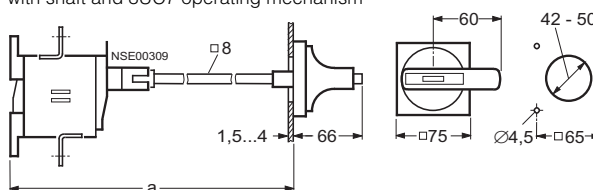

3KA52, 3KA53

Shaft (profile) engaged length:	Shaft length
min. 90 mm	300; unchanged shaft from 8UC72
max. 143 mm	165 ₅₀ ; shortened shaft from 8UC72
	≥ 165 ... ≤ 350 a ₅₀

Type	c	d	e	g	h	i	l	n
3KA52	15	M6 x 20	37	42	91	3	∅ 6.6	106
3KA53	20	M8 x 25	39	39.5	105	3.5	∅ 9	125
4th pole	15	M6 x 20	--	48	91	3	∅ 6.6	106

3KA55, 250 A, 3KA57, 400 A, 3KA58, 630 A
 with shaft and 8UC7 operating mechanism

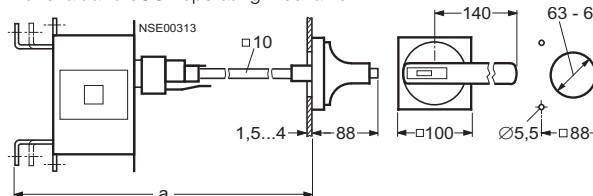

3KA55, 3KA57, 3KA58

Shaft (profile) engaged length:	Shaft length
min. 170 mm	300; unchanged shaft from 8UC73
max. 205 mm	230 ₃₅ ; shortened shaft from 8UC73
	≥ 230 ... ≤ 335 a ₃₅

3KA58

4th pole 3KX3 553-0AA
 for 3KA55, 3KA57, 3KA58

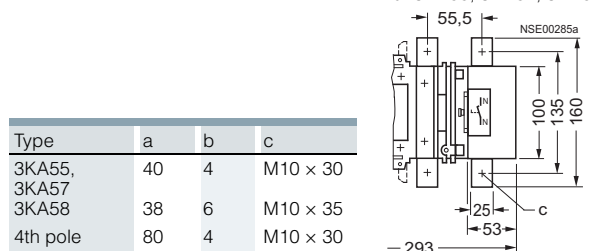

Type	a	b	c
3KA55, 3KA57	40	4	M10 x 30
3KA58	38	6	M10 x 35
4th pole	80	4	M10 x 30

3KA, 3KE, 3LD Switch Disconnectors

3KA, 3KE Switch Disconnectors up to 1000 A

Floor mounting

3KE4

FRONT OPERATING MECHANISM with handle

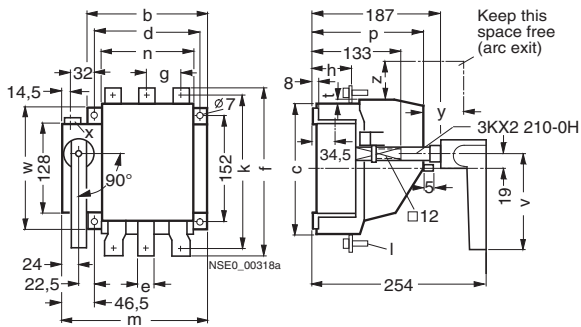

3KE4

Rear rotary operating mechanism without handle

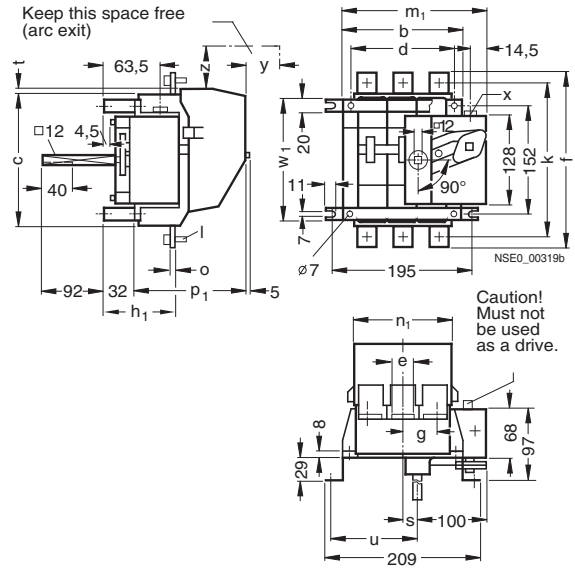

3KX2 210-OH

Coupling socket



Type	b	c	d	e	f	g	h	h ₁	k	l	m	m ₁	n	n ₁	o	p	p ₁	s	t	u	v	w	w ₁	x	y	z
3KE42	155	170	140	25	200	40	60	92	175	M10 × 30	194	194	129	121	4	150	182	15	--	105	140	170	172	M10 × 18	50	50
3KE43	155	170	140	25	200	47	60	92	175	M10 × 30	194	194	129	121	4	150	182	15	--	105	140	170	172	M10 × 18	50	50
3KE44	170	192	155	40	278	55	65	97	238	M12 × 35	209	208	144	136	5	161	193	23	3.5	121	200	172	172	M10 × 18	--	--
3KE45	170	192	155	40	290	65	68	100	250	M12 × 50	209	208	144	136	8	161	193	23	3.5	121	200	172	172	M12 × 25	--	--

3KE4. 30-0EA

with shaft and 8UC7 operating mechanism

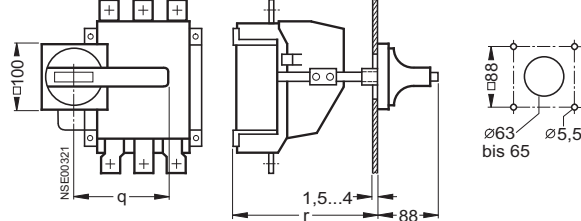

Type	r	Shaft length	q
3KE42, 3KE43	Max. 433	300; unchanged shaft from 8UC73	140
	Min. 200	67; shortened shaft from 8UC73	140
	≥ 200 ... ≤ 433	r - 133	140
3KE44, 3KE45	Max. 433	300; unchanged shaft from 8UC74	140
	Min. 210	77; shortened shaft from 8UC74	140
	≥ 210 ... ≤ 433	r - 133	140

3KX2 210 changeover operating mechanism

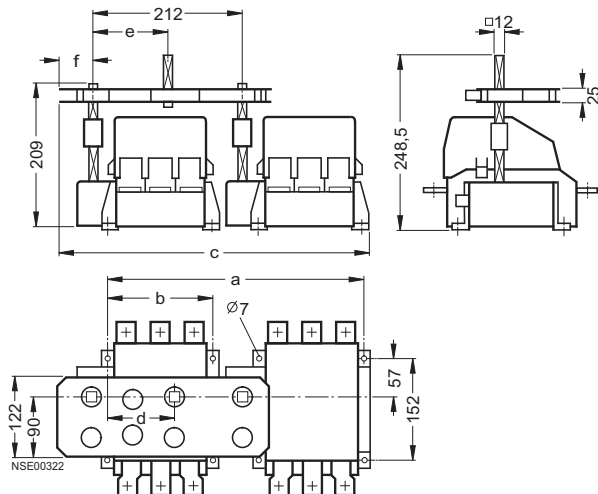

3KX2 250-1A operating linkage

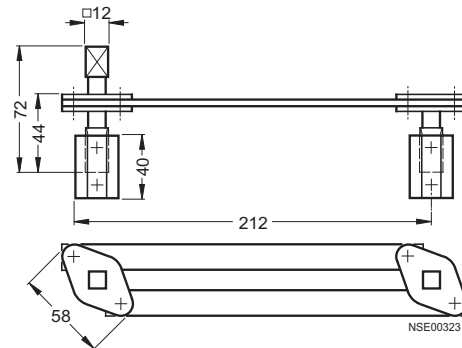

Version	For type	a	b	c	d	e	f	q
With interruption	3KE42, 3KE43	352	140	427	92.5	115	45	200
	3KE44	367	155	442	92.5	115	45	200
	3KE45	367	155	442	92.5	115	55	200
Without interruption	3KE42, 3KE43	352	140	417	74.5	97	35	200
	3KE44	367	155	432	74.5	97	35	200
	3KE45	367	155	432	74.5	97	35	200

3KA, 3KE, 3LD Switch Disconnectors

3LD Main and EMERGENCY-STOP Switches up to 125 A

General data

Overview

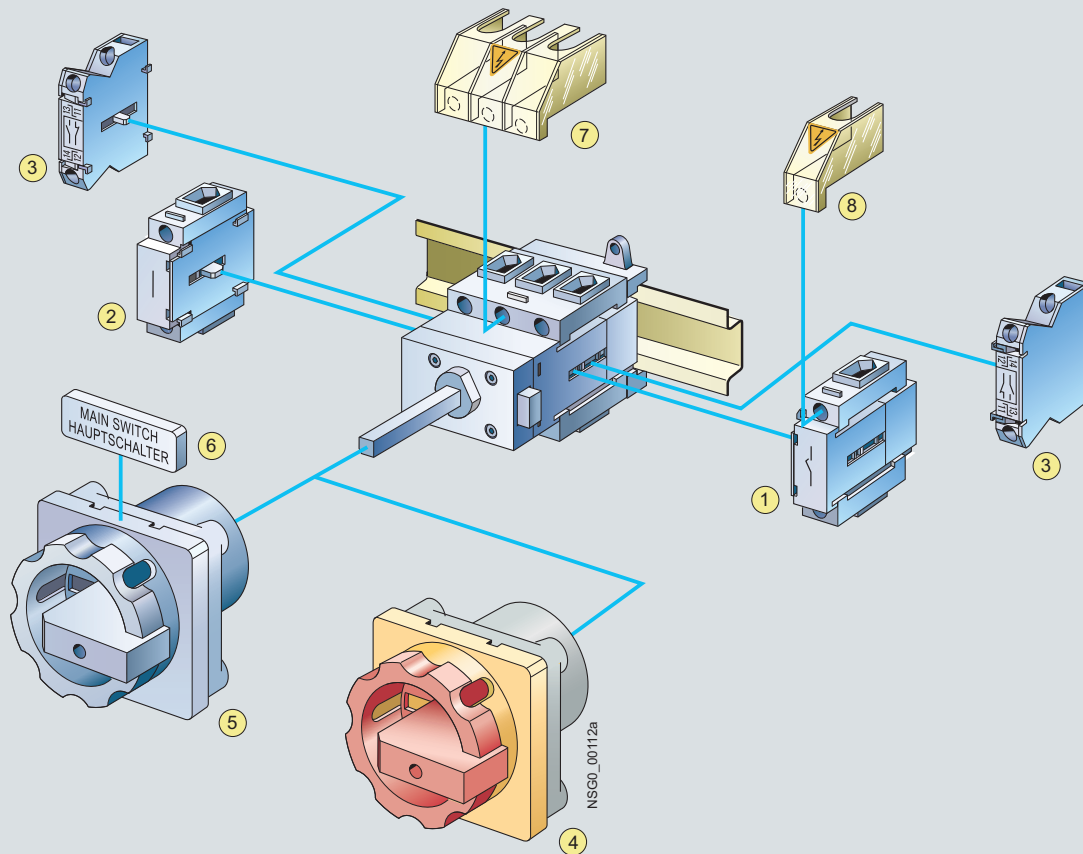

- ① 4th contact (N conductor)
- ② N or PE/ground terminal, continuous
- ③ Auxiliary switch 1 NO + 1 NC
- ④ Rotary operating mechanism, red/yellow
- ⑤ Rotary operating mechanism, black
- ⑥ Front plate, English/German
- ⑦ Terminal cover, three-pole
- ⑧ Terminal cover, single-pole

3KA, 3KE, 3LD Switch Disconnectors

3LD Main and EMERGENCY-STOP Switches up to 125 A

General data

Design

Construction of the contacts

Each switch has three adjacent contact elements¹⁾. A fourth leading contact element for switching the N conductor, a continuous PE/ground terminal, an auxiliary switch (1 NO or 1 NC) can be fitted to each side of the switch. The auxiliary switches operate as leading contacts on opening. On opening, the NO contact opens before the main contacts, so that a contactor carries the switching capacity in the circuit and the maintenance or safety switch switches at zero current. On closing, the auxiliary switch switches later than or at the same time as the main contacts.

Switch construction

Construction of rotary operating mechanisms

The rotary operating mechanisms of the switches for front or floor mounting are mounted on control cabinet doors, front panels or side panels with four-hole or center-hole mounting with a standard diameter of 22.5 mm and operated from the outside. In their Off position, they can be locked with up to three padlocks with a hasp thickness of 8 mm. Controls with defeatable door-coupling rotary operating mechanism are available in addition.

- **Switch position indicator:**
The switch position is clearly marked with direction arrows and an "O" for OFF and a "I" for ON at the front.
- **Switches for front mounting:**
The switches for front mounting are connected directly to the rotary operating mechanism through the fixing screws or - in the case of center-hole mounting - a special-purpose coupling.
- **Switches for floor mounting:**
The switches for floor mounting are snapped onto 35 mm standard mounting rails according to EN 60715 or screw-mounted on mounting plates.

The actuators are connected to the lower section of the switch through a door coupling, which can be released in its zero position, and a 300 mm long switch shaft. When the control cabinet door is open, the switch can be protected against inadvertent operation by removing the switch shaft from the lower section of the switch.

The mounting depth can be adapted to individual requirements by adjusting the switch shaft length.

- **Switches for distribution board mounting:**
The switches for distribution board mounting are suited for operation in switchboards and for switching inside control cabinets or distributors. They have cap and mounting dimensions to DIN 43880 and can be fitted under the same cover together with miniature circuit breakers. The selector knobs can be locked in their OFF position with up to 2 padlocks with a hasp thickness of 6 mm.
- **Switches in molded-plastic enclosure:**
For surface mounting of individual main control and EMERGENCY-STOP switches, molded plastic-enclosed switches to degree of protection IP65 are used. The actuators can be locked in their OFF position with three padlocks with a hasp thickness of 8 mm. The molded-plastic enclosures each contain an N and/or a PE/ground terminal.

1) 16 A versions have four contact elements; 3-pole changeover switches and 6-pole main control switches have six contact elements.



3LD2 203-0TK5 switch for front mounting with rotary operating mechanism



3LD2 222-0TK1 switch for front mounting with selector knob



3LD2 122-7UK01 3-pole changeover switch for front mounting with selector knob



3LD2 103-3VK53 6-pole switch for front mounting with rotary operating mechanism

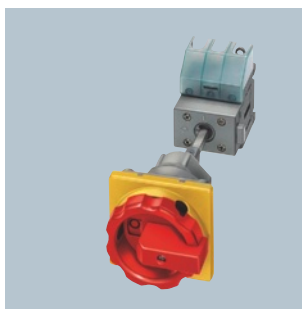

3LD2 213-0TK5 switch for floor mounting with rotary operating mechanism and door coupling



3LD2 530-0TK11 switch for distribution board mounting with selector knob



3LD2 264-0TB5 switch in molded-plastic enclosure



3LD2 217-1TL13 switch for floor mounting with rotary operating mechanism and defeatable door coupling

3KA, 3KE, 3LD Switch Disconnectors

3LD Main and EMERGENCY-STOP Switches up to 125 A

General data

Technical specifications

Standards		DIN VDE 0660, IEC 60947						
Switches	Type	3LD2 0	3LD2 1	3LD2 2	3LD2 5	3LD2 7	3LD2 8	
Number of contacts		3/4	3/4	3/4	3/4	3/4	3/4	
Rated insulation voltage U_i	V	690	690	690	690	690	690	
Rated operational voltage U_e	V AC	690	690	690	690	690	690	
Rated frequency	Hz	50 ... 60	50 ... 60	50 ... 60	50 ... 60	50 ... 60	50 ... 60	
Rated impulse withstand voltage U_{imp}	kV	6	6	6	6	6	6	
Rated short-time withstand current (1 s current, rms value)	A	340	640	640	1260	2000	2000	
Short-circuit protection, max. back-up fuse (gL)	A	20	25	40	63	100	125	
Rated uninterrupted current I_u	A	16	25	32	63	100	125	
AC-21A load-break switch	Rated operational current I_e	A	16	25	32	63	100	125
AC-3 motor load switches	Rating							
In-service switching of individual motors	At 220 V ... 240 V	kW	3.0	4.0	5.5	11.0	18.5	22.0
	At 380 V ... 440 V	kW	5.5	7.5	9.5	18.5	30.0	37.0
	At 660 V/690 V	kW	5.5	7.5	9.5	15.0	22.0	30.0
AC-23A main control switch	Rating							
Repair switch	At 220 V ... 240 V	kW	4.0	5.0	6.0	11.0	18.5	22.0
frequent, but not in-service switching of individual motors	At 380 V ... 440 V	kW	7.5	9.5	11.5	22.0	37.0	45.0
	At 660 V/690 V	kW	7.5	9.5	11.5	18.5	30.0	37.0
Power loss per conducting path at I_e	W	0.5	1.1	1.8	4.5	7.5	12	
Touch protection acc. to IEC 61140		Yes	Yes	Yes	Yes	Yes	Yes	
Endurance	Operating cycles	100 000	100 000	100 000	100 000	100 000	100 000	
Mechanical								
Switching frequency	1/h	50	50	50	50	50	50	
Permissible ambient temperature	°C	-25 ... +55	-25 ... +55	-25 ... +55	-25 ... +55	-25 ... +55	-25 ... +55	
Isolating features	Up to ... V	690	690	690	690	690	690	
Main control and EMERGENCY-STOP switch characteristics¹⁾		Yes	Yes	Yes	Yes	Yes	Yes	
Conductor cross-sections for main conductors								
Connection type	Terminals							
Solid or stranded	1 ... 6	mm ²	1.5 ... 16	1.5 ... 16	2.5 ... 35	4 ... 50	4 ... 50	
Finely stranded with end sleeve (max.)	4	mm ²	10	10	16	35	35	
Auxiliary switches								
Rated insulation voltage U_i	V	500	500	500	500	500	500	
Rated operational voltage U_e	V AC	500	500	500	500	500	500	
Rated uninterrupted current I_u	A	10	10	10	10	10	10	
Rated operational current I_e AC-15	At 120 V	A	6	6	6	6	6	
	At 220 V ... 240 V	A	3	3	3	3	3	
	At 380 V ... 415 V	A	1.8	1.8	1.8	1.8	1.8	
	At 500 V	A	1.4	1.4	1.4	1.4	1.4	
Short-circuit protection, auxiliary switch, max. back-up fuse (gL/gG)	A	10	10	10	10	10	10	
Conductor cross-sections for auxiliary conductors								
Connection type	Terminals							
Solid or stranded	2 × (0.75 ... 2.5)	mm ²	2 × (0.75 ... 2.5)	2 × (0.75 ... 2.5)	2 × (0.75 ... 2.5)	2 × (0.75 ... 2.5)	2 × (0.75 ... 2.5)	
	1 × 4	mm ²	1 × 4	1 × 4	1 × 4	1 × 4	1 × 4	
Finely stranded with end sleeve	2 × (0.75 ... 1.5)	mm ²	2 × (0.75 ... 1.5)	2 × (0.75 ... 1.5)	2 × (0.75 ... 1.5)	2 × (0.75 ... 1.5)	2 × (0.75 ... 1.5)	
	1 × 2.5	mm ²	1 × 2.5	1 × 2.5	1 × 2.5	1 × 2.5	1 × 2.5	
Torque for terminal	Nm	0.8	0.8	0.8	0.8	0.8	0.8	

Standards		UL/CSA						
Switches	Type	3LD2 0	3LD2 1	3LD2 2	3LD2 5	3LD2 7	3LD2 8	
Rated operational voltage U_e	V AC	600	600	600	600	600	600	
Rated uninterrupted current I_u	A	10	20	30	60	100	125	
	Current rating	A 600	A 600	A 600	--	--	--	
	Pilot duty	P 600	P 600	P 600				
Conventional thermal current I_{th}	A	16	25	32	63	100	125	
Maximum rated power (AC-3)	3 ~ 120 V	HP	1	3	3	5	10	15
AC motors 40 Hz ... 60 Hz (HP = PS)	240 V	HP	3	7.5	10	15	30	40
	480 V	HP	7.5	10	20	40	60	75
	600 V	HP	10	15	30	50	75	100
	1 ~ 120 V	HP	0.5	2	2	3	--	--
	240 V	HP	1.5	3	3	10	--	--
Conductor cross-sections Cu cable	AWG	18 ... 10	14 ... 8	14 ... 8	14 ... 6	12 ... 1	12 ... 1	
Torque	Nm	1.5 ... 2	2 ... 2.5	2 ... 2.5	2.5 ... 3	2.5 ... 3	2.5 ... 3	

With appropriate operating mechanisms according to EN 60664-1 (see Catalog LV 1).

3KA, 3KE, 3LD Switch Disconnectors

3LD Main and EMERGENCY-STOP Switches up to 125 A

Front mounting

Dimensional drawings

Switches for center-hole mounting with rotary operating mechanism

3LD2 555

3LD2 .54,

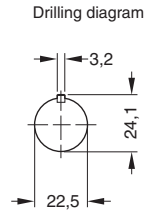
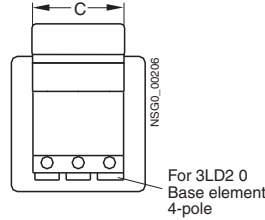
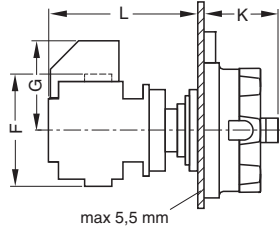
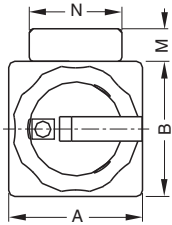

Type	A	B	C	F	G	K	L	M ¹⁾	N ¹⁾
3LD2 054	67	67	48	50	38	37	74	17	47
3LD2 154/3LD2 254	67	67	46	55	44	37	74	17	47
3LD2 555	90	90	60	64	50	46	81	17	47

1) For additional inscription label see Accessories.

Switches for four-hole mounting with rotary operating mechanism

3LD2 .03,
3LD2 .04

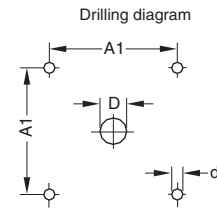
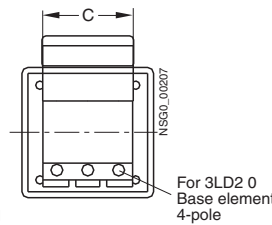
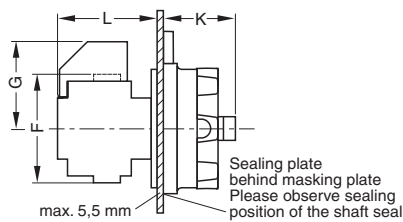
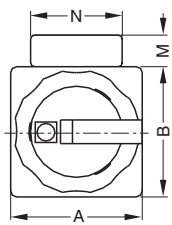

Type	A	B	A1	C	D	d	F	G	K	L	M ¹⁾	N ¹⁾
3LD2 003	67	67	48	48	10	5.0	50	38	37	50	17	47
3LD2 103	67	67	48	46	10	5.0	55	44	37	50	17	47
3LD2 504	90	90	48	60	10	5.0	64	50	46	59	17	47
3LD2 704/3LD2 804	90	90	48	71	10	5.0	83	54	46	61	17	47

1) For additional inscription label see Accessories.

Switches for center-hole mounting with selector knob

3LD2 .50

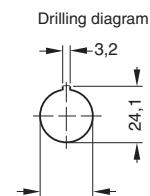
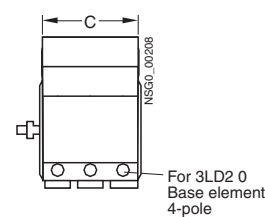
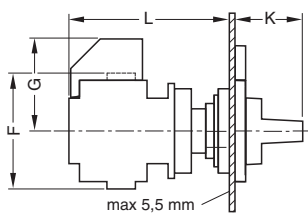
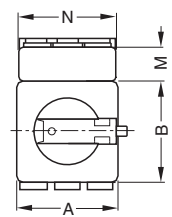

Type	A	B	C	F	G	K	L	M ¹⁾	N ¹⁾
3LD2 050	49	49	48	50	38	34	74	17	47
3LD2 150/3LD2 250	49	49	46	55	44	34	74	17	47

1) For additional inscription label see Accessories.

3KA, 3KE, 3LD Switch Disconnectors

3LD Main and EMERGENCY-STOP Switches up to 125 A

Front mounting

Switches for four-hole mounting with selector knob

3LD2 .22

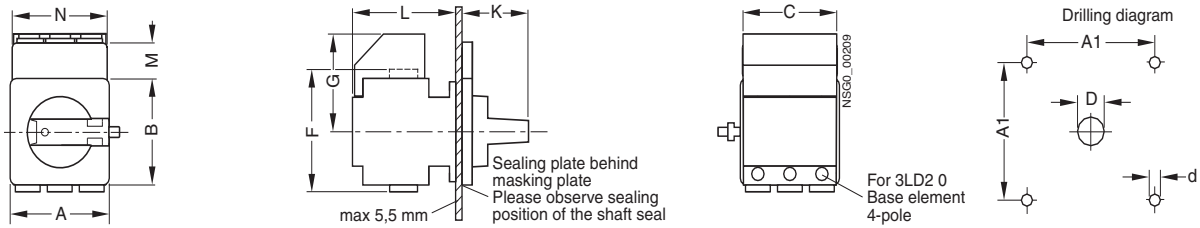

Type	A	B	A1	C	D	d	F	G	K	L	M ¹⁾	N ¹⁾
3LD2 022	49	49	36	48	10	5.0	50	38	34	50	17	47
3LD2 122/3LD2 222	49	49	36	46	10	5.0	55	44	34	50	17	47

1) For additional inscription label see [Accessories](#).

Switches for four-hole mounting with rotary operating mechanism

3LD2 103-.V..., 3LD2 203-.V..., 3LD2 504-.V...

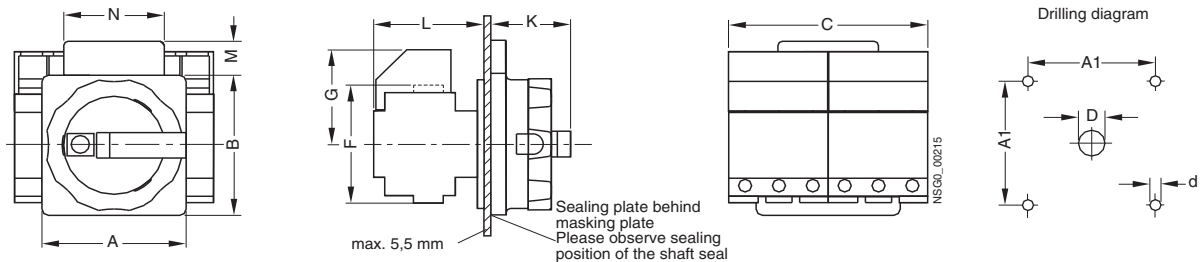

Type	A	B	A1	C	D	d	F	G	K	L	M ¹⁾	N ¹⁾
3LD2 103-.V...	67	67	48	92	10	5.0	55	44	37	50	17	47
3LD2 203-.V...	67	67	48	92	10	5.0	55	44	37	50	17	47
3LD2 504-.V...	90	90	68	121	10	5.0	64	50	46	59	17	47

1) For additional inscription label see [Accessories](#).

Switches for four-hole mounting with selector knob

3LD2 122-.V...

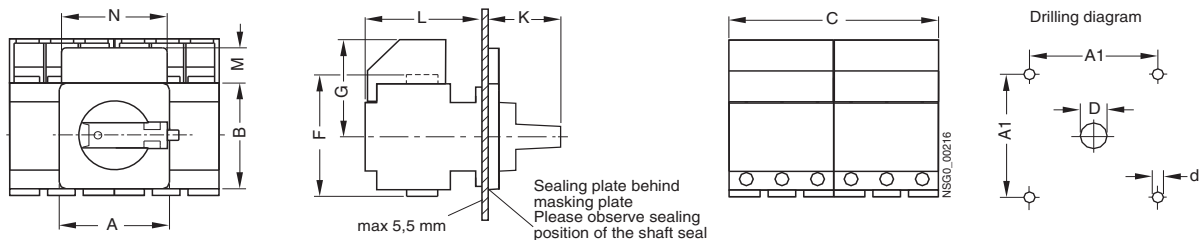

Type	A	B	A1	C	D	d	F	G	K	L	M ¹⁾	N ¹⁾
3LD2 122-.V...	49	49	36	92	10	5.0	55	44	32	50	17	47

1) For additional inscription label see [Accessories](#).

3KA, 3KE, 3LD Switch Disconnectors

3LD Main and EMERGENCY-STOP Switches up to 125 A

Front mounting

Changeover switches

3LD2 123-7U..., 3LD2 223-7U...,
3LD2 524-7U..., 3LD2 724-7U...

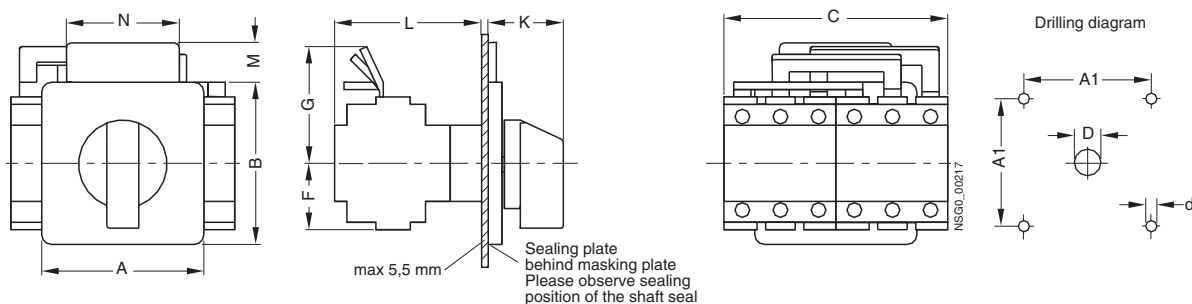

Type	A	B	A1	C	D	d	F	G	K	L	M ¹⁾	N ¹⁾
3LD2 123-7U...	67	67	48	92	10	5.0	28	46	34	63.5	17	47
3LD2 223-7U...	67	67	48	92	10	5.0	28	46	34	63.5	17	47
3LD2 524-7U...	92	92	68	121	10	5.5	32	53	40	73	17	47
3LD2 724-7U...	92	92	68	141	10	5.5	42	68	40	75	17	47

1) For additional inscription label see [Accessories](#).

3KA, 3KE, 3LD Switch Disconnectors

3LD Main and EMERGENCY-STOP Switches up to 125 A

Floor mounting

Dimensional drawings

Switches for floor mounting with detachable rotary operating mechanism (four-hole mounting)

3LD2 .13,
3LD2 14.

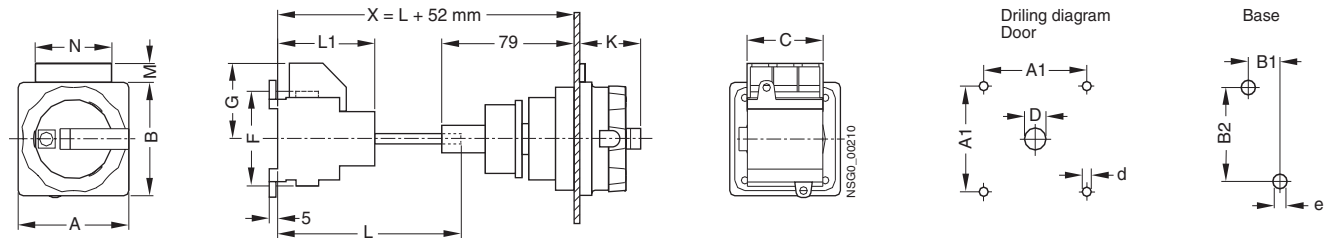

Type	A	B	A1	B1	B2	C	D	d	e	F	G	K	L	L1	M ¹⁾	N ¹⁾	X _{min}
3LD2 013	67	67	48	22	60	48	10	5.0	4.5	50	38	37	330	58	17	47	138
3LD2 113/3LD2 213	67	67	48	22	60	46	10	5.0	4.5	55	44	37	330	58	17	47	138
3LD2 514	90	90	48	25	70	60	10	5.5	5.5	64	50	46	338	68	17	47	148
3LD2 714/3LD2 814	90	90	48	25	90	71	10	5.5	5.5	83	54	46	340	70	17	47	150

1) For additional inscription label see Accessories.

Switches for floor mounting with detachable rotary operating mechanism (center-hole mounting)

3LD2 .44,
3LD2 .45

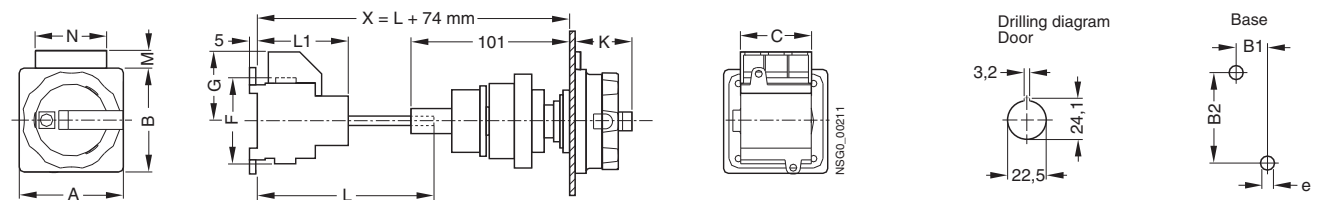

Type	A	B	B1	B2	C	e	F	G	K	L	L1	M ¹⁾	N ¹⁾	X _{min}
3LD2 044	67	67	22	60	48	4.5	50	38	37	330	58	17	47	160
3LD2 144/3LD2 244	67	67	22	60	46	4.5	55	44	37	330	58	17	47	160
3LD2 545	90	90	25	70	60	5.5	64	50	46	338	68	17	47	170

1) For additional inscription label see Accessories.

Switches for floor mounting with detachable rotary operating mechanism (four-hole mounting)

3LD2 113-V...

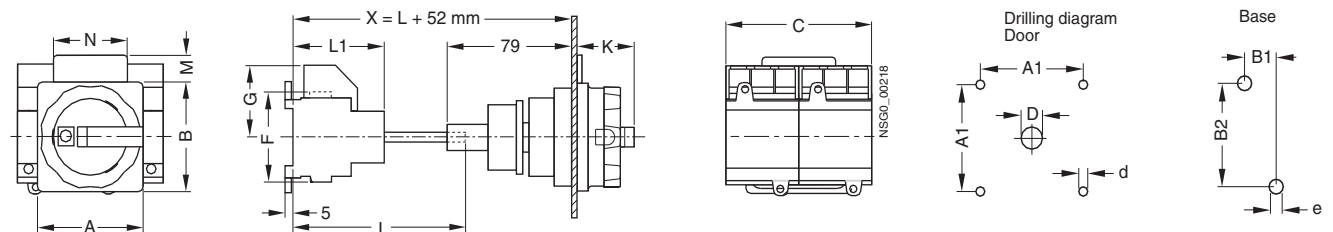

Type	A	B	A1	B1	B2	C	D	d	e	F	G	K	L	L1	M ¹⁾	N ¹⁾	X _{min}
3LD2 113-V...	67	67	48	22	60	92	10	5.0	4.5	55	44	37	330	58	17	47	138

1) For additional inscription label see Accessories.

3KA, 3KE, 3LD Switch Disconnectors

3LD Main and EMERGENCY-STOP Switches up to 125 A

Distribution board mounting

Dimensional drawings

Switches for distribution board mounting with selector knob

3LD2 .30

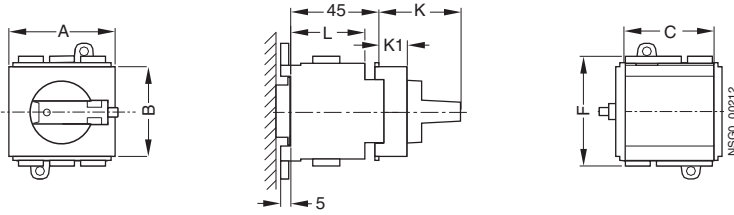

Type	A	B	C	F	K	K1	L
3LD2 030	53	45	48	50	41	14	37
3LD2 130	53	45	46	55	41	14	37
3LD2 230	53	45	46	55	41	14	37
3LD2 530	64	45	60	64	43	16	44
3LD2 730	71	45	71	83	47	19	44
3LD2 830	71	45	71	83	47	19	44

1) For additional inscription label see [Accessories](#).

3KA, 3KE, 3LD Switch Disconnectors

3LD Main and EMERGENCY-STOP Switches up to 125 A

Molded-plastic enclosures

Dimensional drawings

Switches with molded-plastic enclosure with rotary operating mechanism

Metric screwed glands

3LD2 .64,
3LD2 .65,
3LD2 .66

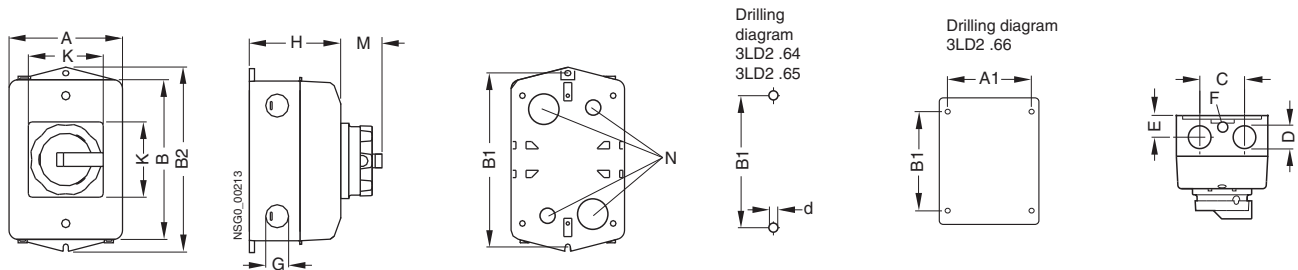

Type	A	B	A1	B1	B2	C	d	D	E	F	G	H	K	M	N
3LD2 .64-...5.	100	140	--	152	164	46	4.5	4 x M25	24	--	4 x M20	81	67	36	2 x M20, 2 x M40
3LD2 .65-...5.	146	176	--	188	199	66	4.5	4 x M32/4C	37	--	4 x M20	104	90	45	2 x M20, 2 x M40
3LD2 .66-...5.	212	302	189	238	302	84	6.5	4 x M50/63	57	2 x M20	4 x M20	136	90	45	2 x M20, 2 x M50
3LD2 566-V...	212	302	189	238	302	84	6.5	4 x M32/4C	57	2 x M20	4 x M20	136	90	45	2 x M20, 2 x M50

Switches in molded-plastic enclosure with selector knob

3LD2 .6-7U...

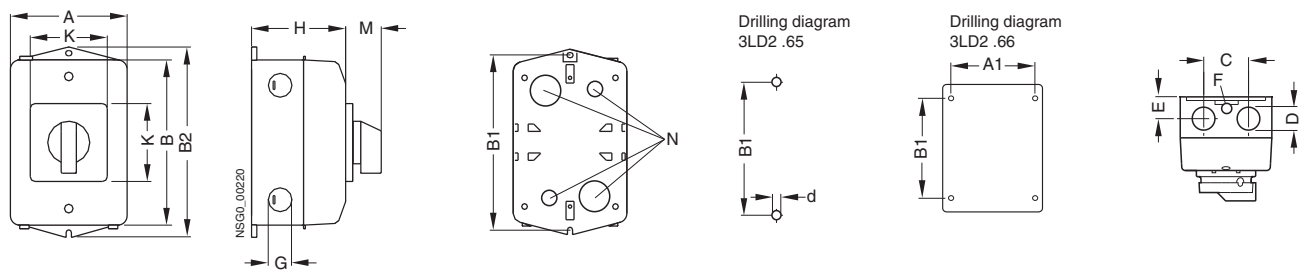

Type	A	B	A1	B1	B2	C	d	D	E	F	G	H	K	M	N
3LD2 165-7U...	146	176	--	188	199	66	4.5	4 x M32/40	37	--	4 x M20	104	67	32	2 x M20, 2 x M40
3LD2 265-7U...	146	176	--	188	199	66	4.5	4 x M32/40	37	--	4 x M20	104	67	32	2 x M20, 2 x M40
3LD2 566-7U...	212	302	189	238	302	84	6.5	4 x M32/40	57	2 x M20	4 x M20	136	90	45	2 x M20, 2 x M50
3LD2 766-7U...	212	302	189	238	302	84	6.5	4 x M50/63	57	2 x M20	4 x M20	136	90	45	2 x M20, 2 x M50

3KA, 3KE, 3LD Switch Disconnectors

3LD Main and EMERGENCY-STOP Switches up to 125 A

Accessories

Dimensional drawings

Front mounting

3LD9 2.0-0B

4th contact element (N conductor) for front mounting, leading switch-on, delayed switch-off

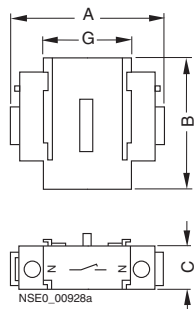

Type	A	B	C	G
3LD9 220-0B	54.5	40.5	15.5	31.5
3LD9 250-0BA	64.5	47.0	20.0	37.0
3LD9 280-0B	83.5	44.0	23.0	20.0

3LD9 2.0-2B

N or PE/ground terminal

for front mounting, leading switch-on, delayed switch-off

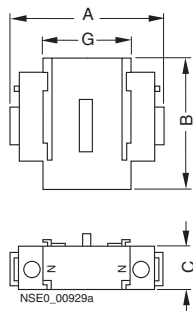

Type	A	B	C	G
3LD9 200-2B	50.0	40.0	13.0	31.0
3LD9 220-2B	54.5	40.5	15.5	31.5
3LD9 250-2BA	64.5	47.0	20.0	37.0
3LD9 280-2B	83.5	44.0	23.0	20.0

3LD9 286-1A, 3LD9 286-4A

inscription label

German/English, neutral

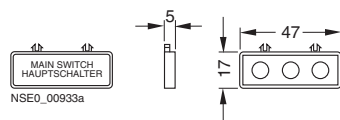

Front and floor mounting

3LD9 2.4-1B, 3LD9 2.4-3B

rotary operating mechanism for four-hole mounting
black, red/yellow

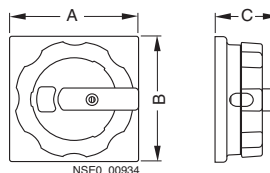

Type	A	B	C
3LD9 224-1B	67.0	67.0	37.0
3LD9 224-3B	67.0	67.0	37.0
3LD9 284-1B	90.0	90.0	46.0
3LD9 284-3B	90.0	90.0	46.0

3LD9 2.4-1D, 3LD9 2.4-3D

rotary operating mechanism for center-hole mounting
black, red/yellow

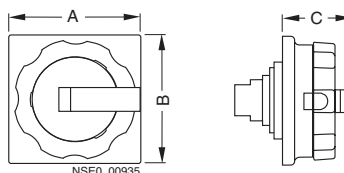

Type	A	B	C
3LD9 224-1D	67.0	67.0	37.0
3LD9 224-3D	67.0	67.0	37.0
3LD9 284-1D	90.0	90.0	46.0
3LD9 284-3D	90.0	90.0	46.0

3LD9 2.1-2A

terminal cover as additional touch protection
for snap fitting at top or bottom, 1-pole

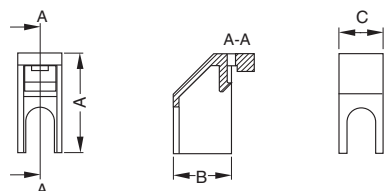

Type	A	B	C
3LD9 201-2A	34.5	15.0	10.0
3LD9 221-2A	34.5	20.0	15.0
3LD9 251-2A	40.5	21.5	20.0
3LD9 281-2A	45.0	17.5	23.0

3KA, 3KE, 3LD Switch Disconnectors

3LD Main and EMERGENCY-STOP Switches up to 125 A

Accessories

3LD9 2.1-A

terminal cover as additional touch protection
for snap fitting at top or bottom, 1-pole

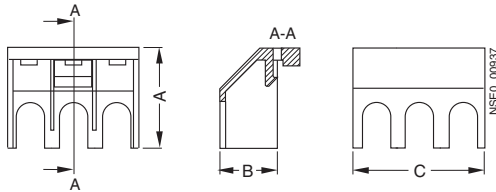

Type	A	B	C
3LD9 201-1A	34.5	15.0	46.0
3LD9 221-0A	34.5	20.0	46.0
3LD9 251-0A	40.5	21.5	60.0

3LD9 200-5.. auxiliary switch

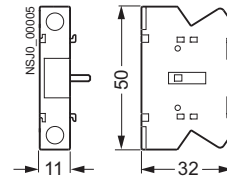

Floor and distribution board mounting

3LD9 2.0-0C

4th contact element (N conductor)

for front mounting, leading switch-on, delayed switch-off

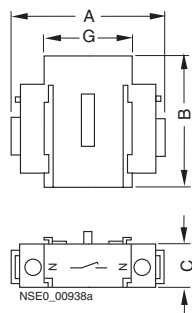

Type	A	B	C	G
3LD9 220-0C	54.5	40.5	15.5	31.5
3LD9 250-0CA	64.5	47.0	20.0	37.0
3LD9 280-0C	83.5	44.0	23.0	20.0

3LD9 2.0-2C

N or PE terminal

through-out

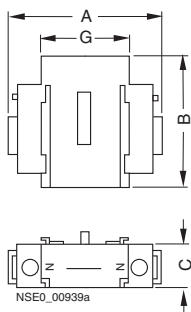

Type	A	B	C	G
3LD9 200-2C	50.0	40.0	13.0	31.0
3LD9 220-2C	54.5	40.5	15.5	31.5
3LD9 250-2CA	64.5	47.0	20.0	37.0
3LD9 280-2C	83.5	44.0	23.0	20.0

3KL, 3KM, 3NJ6 Switch Disconnectors with Fuses

3KL Switch Disconnectors with Fuses up to 800 A

General data

Overview

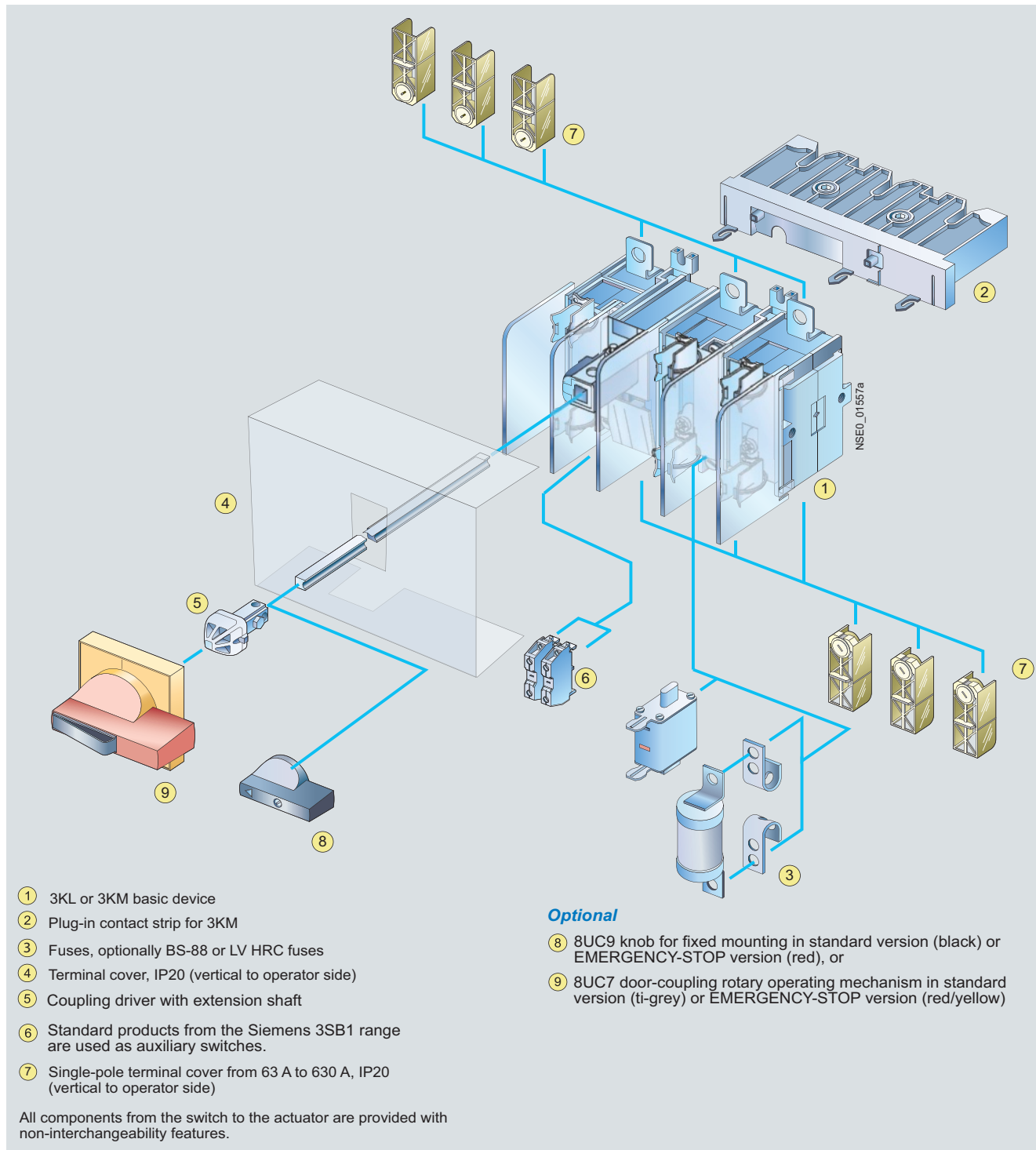

Design

All switch disconnectors feature double contact interruption and an isolating distance. As a result, the fuses of the switch disconnectors are de-energized in the OFF position.

The 3KM switch disconnectors with fuses also feature an isolating plug connector. This facilitates mounting and contact establishment in motor control centers (MCCs) in conjunction with vertical busbars.

Generally, all 3K. 5 switch disconnectors can be secured on the shaft with a padlock to prevent unauthorized reclosing. Identical accessories for 3KA switch disconnectors and for 3KL and 3KM switch disconnectors with fuses simplify stock keeping.

Please inquire about a special variant with reduced values that is particularly resistant to atmospheres high in sulfur, e. g. in the paper and cellulose processing industries.

3KL, 3KM, 3NJ6 Switch Disconnectors with Fuses

3KL Switch Disconnectors with Fuses up to 800 A

General data

Technical specifications

Standards	Type	IEC 60947-1, IEC 60947-3, VDE 0660 Part 107						
		3KL50	3KL52 ¹⁾	3KL53 ¹⁾	3KL55 ¹⁾	3KL57 ¹⁾	3KL61 ¹⁾	3KL62 ¹⁾
Rated uninterrupted current I_u For fuse links acc.to DIN 43620, (when SITOR semiconductor fuses are used, a reduction of rated current is necessary, see Catalog SITOR Configuration, Order No. E20001-A700-P302)	A Size	63 00 and 000	125 00 and 000	160 00 and 000	250 1 and 2	400 1 and 2	630 3 and 2	800 3 and 2
Conventional free-air thermal current $I_{th}^{(2)}$	A	63	125	160	250	400	630	800
Rated insulation voltage U_i	V	690	1000	1000	1000	1000	1000	1000
Rated impulse voltage U_{imp}	kV	6	8	8	8	8	8	8
Rated operational voltage U_e AC 50 Hz/60 Hz DC	V V	690 440 (3 conducting paths series-connected) 220 (2 conducting paths series-connected) ³⁾						
Rated short-circuit making capacity with fuses³⁾ At 50 Hz/60 Hz 690 V AC	kA (peak value)	220	220	220	176	176	105	105
Rated conditional short-circuit current with fuses³⁾ At 50 Hz/60 Hz 690 V AC	kA (rms value)	100	100	100	80	80	50	50
Max. rated current I_n of the fuses	A	80	160	160	400	400	630	800
Max. permissible power loss of the installed fuse LV HRC	W	6	9	11.5	32	45	48	62
BS	W	8 (A2/A3)	11.5 (A4)	11.5	32	45	48	60.5
Permissible let-through current of the fuses	kA	8	17	17	30 ⁵⁾	30 ⁵⁾	50	50
Maximum permissible let-through I^2t value	kA ² s	55	223	223	1000	1000	5400	10500
Switching capacity (infeed from top or bottom)								
At 400 V AC Breaking current I_c (p.f. = 0.35)	A (rms value)	500	1000	1280	2000	3200	5100	6400
Rated operational current I_e at AC-21A, AC-22A, AC-23A	A	63	125	160	250	400	630 ⁶⁾	800 ⁶⁾
Motor switching capacity AC-23A	kW	30	65	80	132	200	335	400
At 500 V AC Breaking current I_c (p.f. = 0.35)	A (rms value)	500	1000	1280	2000	3200	5100	6400
Rated operational current I_e at AC-21A, AC-22A, AC-23A	A	63	125	160	250	400	630 ⁶⁾	800 ⁶⁾
Motor switching capacity AC-23A	kW	40	90	110	185	280	425	500
At 690 V AC Breaking current I_c (p.f. = 0.35)	A (rms value)	500	1000	1280	2000	3200	5100	6400
Rated operational current I_e at AC-21A, AC-22A, AC-23A	A	63	125	160	250	400	630 ⁵⁾	800 ⁵⁾
Motor switching capacity AC-23A	kW	50	110	150	220	375	560	700
At 440 V DC (3 conducting paths series-connected) ⁷⁾ Breaking current I_c (L/R = 15 ms)	A	250	500	640	1000 ⁸⁾	1600	2520 ⁹⁾	2520 ⁹⁾
Rated operational current I_e at DC-23A	A	63	125	160	250 ¹⁰⁾	400	630 ¹⁰⁾	800 ¹⁰⁾
Rated short-time current (1 s current)	kA (rms value)	2.5	3.2	3.2	8	11	32	32
Permissible load Depending on the ambient temperature for open-type installation in control panels (e. g. 8NA1) in control cubicles or control racks at								
35 °C	A	63	125	160	250	400	630	800
40 °C	A	63	125	155	250	390	630	780
45 °C	A	63	125	150	250	380	610	760
50 °C	A	63	125	145	250	370	590	740
55 °C	A	63	125	140	240	360	570	720
Permissible ambient temperature	°C °C	-25 ... +55 for operation ³⁾ , -50 ... +80 when stored						
Mechanical endurance	Operat- ing cycles	15000	15000	15000	12000	12000	3000	3000
Required operating torque	Nm	3	7.5	7.5	16	16	30	30
Degree of protection		IP00/IP20 (from the operator side, with fuse and terminal covers)						
Power loss of the switch disconnector at I_{th} (plus power loss of the fuses)	W	8.5	22	36	33	86	140	225
Main conductor connections Busbar systems, max. dimensions (w x t)	mm x mm	25 x 9	45 x 10	45 x 10	40 x 12	40 x 15	40 x 17	40 x 17

For footnotes see next page.

3KL, 3KM, 3NJ6 Switch Disconnectors with Fuses

3KL Switch Disconnectors with Fuses up to 800 A

General data

Standards		IEC 60947-1, IEC 60947-3, VDE 0660 Part 107						
		3KL50	3KL52 ¹⁾	3KL53 ¹⁾	3KL55 ¹⁾	3KL57 ¹⁾	3KL61 ¹⁾	3KL62 ¹⁾
Type								
Cable lug, max. conductor cross-section (stranded)	mm ²	35	70	120	150	2 x 150 or 1 x 240	2 x 240	2 x 240
Tightening torque	Nm	6 ... 7.5	7 ... 10	18 ... 22	35 ... 45	35 ... 45	56	56
Terminal screws		M6	M6	M8	M10	M10	M12	M12
Protective conductor connections								
Flat bars	mm x mm	--	--	--	20 x 2.5	20 x 2.5	--	--
Cable lug, max. conductor cross-section (stranded)	mm ²	--	--	--	70	120	--	--
Auxiliary switch 1 NO + 1 NC (accessories)								
Max. number to be plugged		1	2	2	2	2	3	3
Rated operational current I_e at AC 50 Hz/60 Hz								
I_e /AC-12	A	10						
I_e /AC-15 at $U_e = 220$ V/230 V	A	6						
I_e /AC-15 at $U_e = 380$ V/400 V	A	4						
I_e /AC-15 at $U_e = 500$ V	A	2.5						
I_e /AC-15 at $U_e = 690$ V	A	1.2						
Rated operational current I_e at DC								
I_e /DC-13 at $U_e = 24$ V	A	10						
I_e /DC-13 at $U_e = 48$ V	A	4						
I_e /DC-13 at $U_e = 110$ V	A	1.2						
I_e /DC-13 at $U_e = 220$ V	A	0.4						
I_e /DC-13 at $U_e = 440$ V	A	0.2						
Connection								
Solid	mm ²	2 x (0.5 ... 1.5)						
Finely stranded with end sleeve	mm ²	2 x (1 ... 2.5)						
Weight								
Complete version	kg	1.450	2.560	2.560	5.400	5.700	--	--
Basic version	kg	0.950	2.200	2.200	4.500	4.800	14.000	14.000

- 1) Technical specifications for approval on request.
- 2) Configuring note: max. permissible operating temperature for fuse blades 135 °C, for connections 100 °C.
- 3) 110 V (one conducting path).
- 4) With 3KL61 for operation -25 °C ... +35 °C, at +55 °C: $I_{th} = 570$ A.
- 5) 3ND1 switchgear protection fuse.
- 6) AC-23B.
- 7) 220 V DC (L1 and L3 series-connected) or 110 V DC (one conducting path) at DC-23A.
- 8) At 440 V $L/R = 4$ ms, at 220 V $L/R = 15$ ms.
- 9) $L/R = 2.5$ ms.
- 10) At 440 V DC-22A, at 220 V DC-23A.

Permissible mounting positions

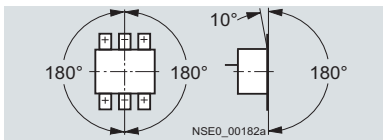

Mounting position for 3KL switch disconnectors

Note:

For the 3KL switch disconnectors, complete kits for standard and EMERGENCY-STOP application are available for installation in the side and rear panels of control cabinets.

3KL, 3KM, 3NJ6 Switch Disconnectors with Fuses

3KL Switch Disconnectors with Fuses up to 800 A

Surface mounting and installation

Dimensional drawings

3KL50, 63 A, 3-pole, dimensional drawing for 4-pole version corresponds to dimensional drawing for 3KL52;
without operating mechanism, with lyre-shaped contacts

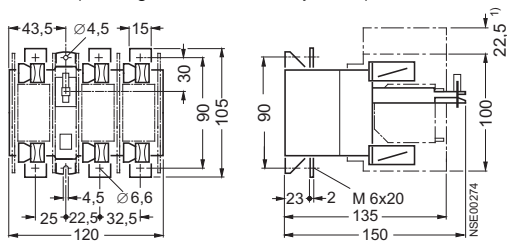

1) To be kept free of conductive parts. Not necessary when using lyre-shaped contacts or covers (accessories).

3KL50, 30, 63 A, 3-pole, dimensional drawing for 4-pole version corresponds to dimensional drawing for 3KL52;
without operating mechanism, for BS fuses

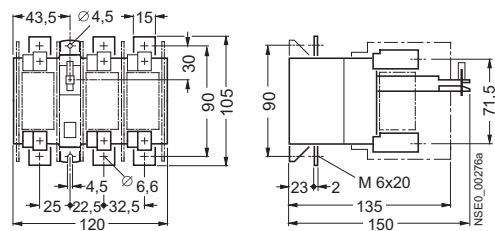

3KL52, 125 A, 3KL53, 160 A, 3KL50, 63 A, 4-pole
without operating mechanism, with lyre-shaped contacts

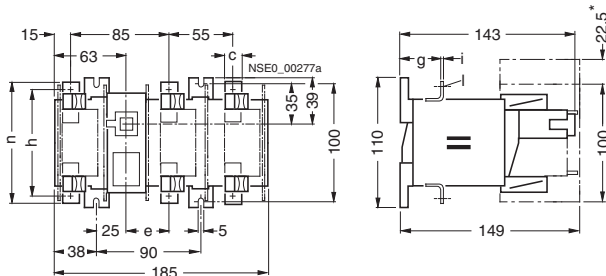

* To be kept free of conductive parts. Not necessary when using lyre-shaped contacts or covers (accessories).

Type	c	e	g	h	n
3KL52 NH	15	37	42	91	106
3KL53 NH	20	39	39.5	105	125
3KL52 A2/A3	15	37	42	91	106
3KL53 A4	20	39	39.5	105	125
4th pole	15	--	48	91	106

IP20 cover for 3KL

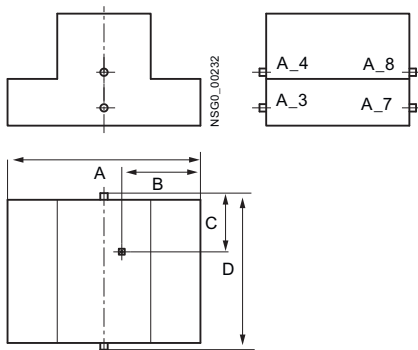

3KL50, 63 A
with shaft and 8UC7 operating mechanism

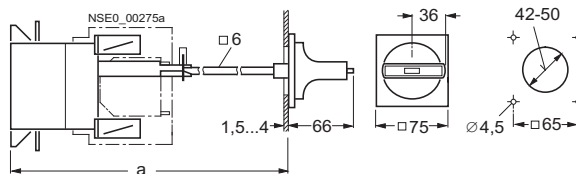

a	Shaft length
Max. 380	300; unchanged shaft from 8UC71
Min. 175	175 _{.80} ; shortened shaft from 8UC71
175 < a < 380	a _{.80}

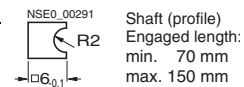

3KL52, 125 A, 3KL53, 160 A
with shaft and 8UC7 operating mechanism

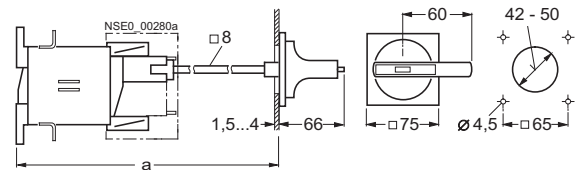

a	Shaft length
Max. 350	300; unchanged shaft from 8UC72
Min. 165	165 _{.50} ; shortened shaft from 8UC72
165 < a < 350	a _{.50}

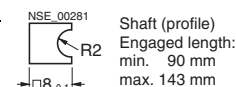

3KL52, 125 A, 3KL53, 160 A, 3KL50, 63 A, 4-pole
without operating mechanism, for BS fuses

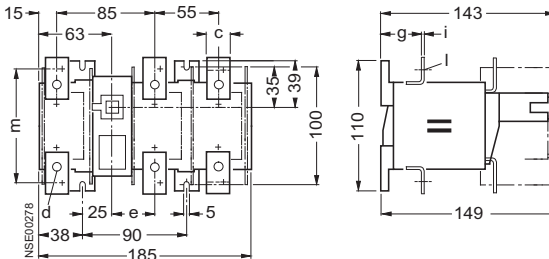

Type	c	e	g	h	n
3KL52 NH	15	37	42	91	106
3KL53 NH	20	39	39.5	105	125
3KL52 A2/A3	15	37	42	91	106
3KL53 A4	20	39	39.5	105	125
4th pole	15	--	48	91	106

Type	For	A	B	C	D
3KX3507-OCA02	3KL50	210	90	50	130
3KX3527-OCA02	3KL52	260	114	72.5	208
3KX3537-OCA02	3KL53	260	114	72.5	208
3KX3557-OCA02	3KL55	340	142	101	262
3KX3557-OCA02	3KL57	340	142	101	262

3KL, 3KM, 3NJ6 Switch Disconnectors with Fuses

3KL Switch Disconnectors with Fuses up to 800 A

Surface mounting and installation

3KL55, 250 A, 3KL57, 400 A

without operating mechanism, with lyre-shaped contacts

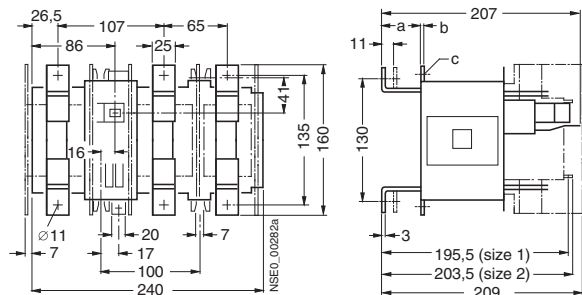

Type	a	b	c
3KM55	40	4	M 10 x 30
3KM57	38	6	M 10 x 36
4th pole	80	4	M 10 x 30

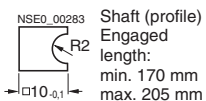

3KL55, 250 A, 3KL57, 400 A

with shaft and 8UC7 operating mechanism

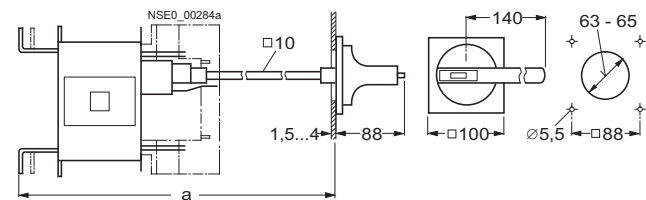

a	Shaft length
Max. 335	300; unchanged shaft from 8UC73
Min. 230	230 ₃₅ ; shortened shaft from 8UC73
230 < a < 335	a ₃₅

3KL61, 630 A, 3KL62, 800 A

without operating mechanism, with lyre-shaped contacts, with partitions

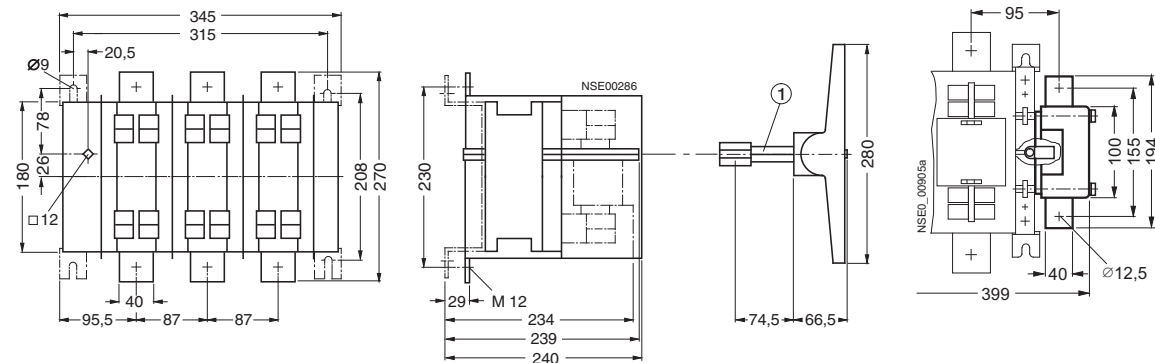

Total installation depth with handle:
239 + 74,5 + 66,5 = 370

- ① Profile 12 x 12.
Shaft length 110.
Shaft can be turned by 45°

4th pole
for 3KL61

Schematics

Internal circuit diagram for 3KL

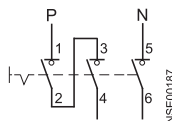
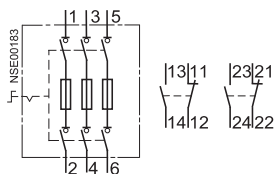

(for 3KL50 and 3KL51, only one auxiliary switch possible, not included in scope of supply; 4th pole is possible as main contact)

(auxiliary switch not included in scope of supply) Use for DC voltage at DC-23A 440 V

3KL, 3KM, 3NJ6 Switch Disconnectors with Fuses

3KM Switch Disconnectors with Fuses and Isolating Plug Connector up to 400 A

General data

Overview

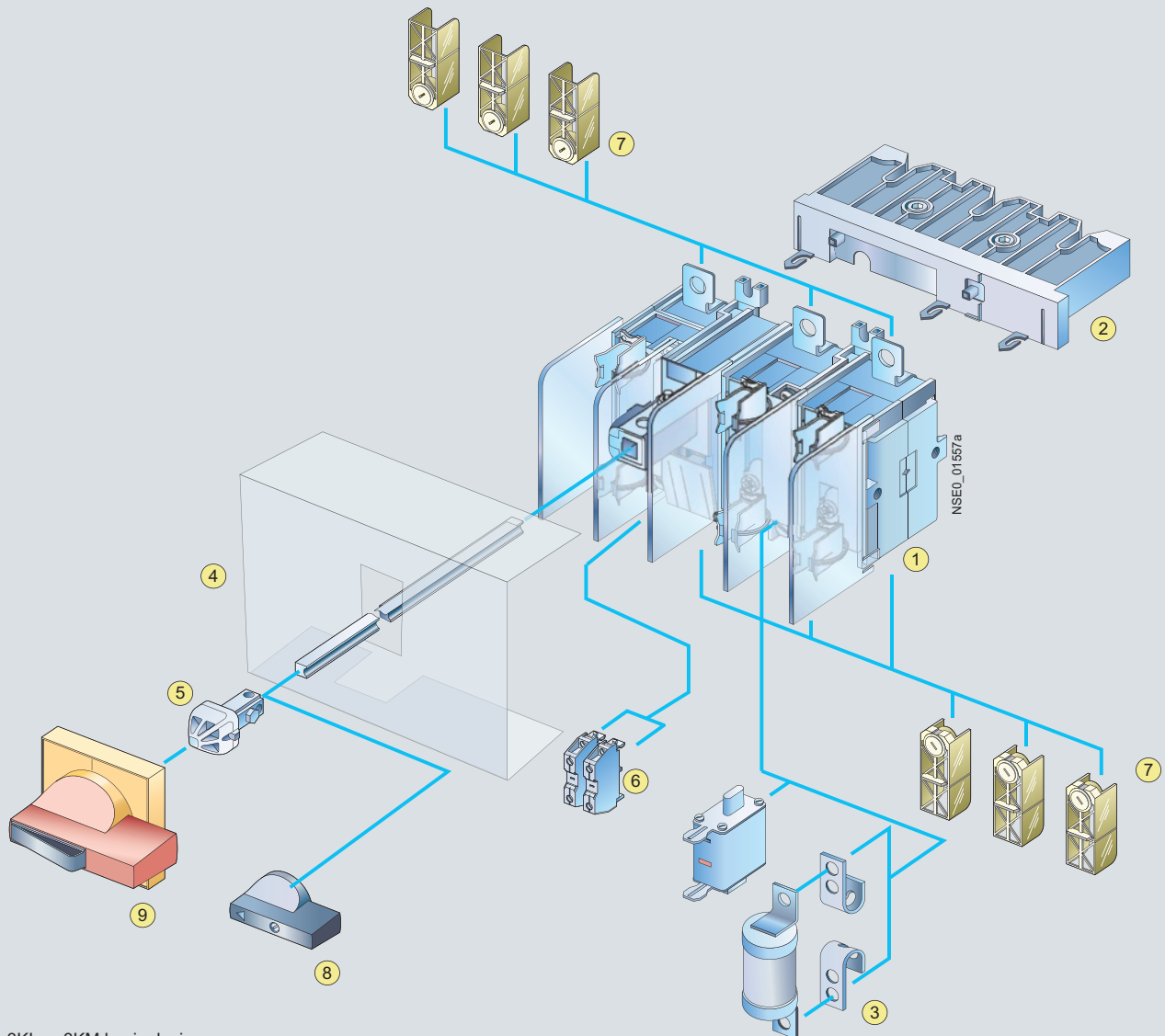

- ① 3KL or 3KM basic device
- ② Plug-in contact strip for 3KM
- ③ Fuses, optionally BS-88 or LV HRC fuses
- ④ Terminal cover, IP20 (vertical to operator side)
- ⑤ Coupling driver with extension shaft
- ⑥ Standard products from the Siemens 3SB1 range are used as auxiliary switches.
- ⑦ Single-pole terminal cover from 63 A to 630 A, IP20 (vertical to operator side)

Optional

- ⑧ 8UC9 knob for fixed mounting in standard version (black) or EMERGENCY-STOP version (red), or
- ⑨ 8UC7 door-coupling rotary operating mechanism in standard version (ti-grey) or EMERGENCY-STOP version (red/yellow)

All components from the switch to the actuator are provided with non-interchangeability features.

Design

All switch disconnectors feature double contact interruption and an isolating distance. As a result, the fuses are de-energized when the switch disconnectors are in the disconnected position.

The 3KM switch disconnectors with fuses also feature an isolating plug connector. This facilitates mounting and contact establishment in motor control centers (MCCs) in conjunction with vertical busbars. Generally, all 3K.5 switch disconnectors can be secured on the shaft with a padlock to prevent unauthorized reclosing.

Identical accessories for 3KA switch disconnectors and for 3KL and 3KM switch disconnectors with fuses simplify stock keeping.

Please inquire about a special variant with reduced values that is particularly resistant to atmospheres high in sulfur, e. g. in the paper and cellulose processing industries.

3KL, 3KM, 3NJ6 Switch Disconnectors with Fuses

3KM Switch Disconnectors with Fuses and Isolating Plug Connector up to 400 A

General data

Technical specifications

Standards	Type	IEC 60947-1, IEC 60947-3, VDE 0660 Part 107				
		3KM50	3KM52	3KM53	3KM55	3KM57
Rated uninterrupted current I_u For fuse links acc. to DIN 43620, (when SITOR semiconductor fuse links are used, a reduction of rated current is necessary, see Catalog SITOR Configuration, Order No. E20001-A700-P302)	A Size	63 00 and 000	125 00 and 000	160 00 and 000	250 1 and 2	400 1 and 2
Conventional free-air thermal current $I_{th}^{(1)}$	A	63	125	160	250	400
Rated insulation voltage U_i	V	690	1000	1000	1000	1000
Rated impulse voltage U_{imp}	kV	6	8	8	8	8
Rated operational voltage U_e AC 50 Hz/60 Hz DC	V V V	690 440 (3 conducting paths series-connected) 220 (2 conducting paths series-connected) ²⁾				
Rated short-circuit making capacity with fuses At 50 Hz/60 Hz 690 V AC	kA (peak value)	220	220	220	176	176
Rated conditional short-circuit current with fuses At 50 Hz/60 Hz 690 V AC	kA (rms value)	100	100	100	80	80
Max. rated current I_n of the fuses	A	80	160	160	400	400
Max. permissible power loss of the installed fuse LV HRC	W	6	9	11.5	32	45
BS	W	8 (A2/A3)	11.5 (A4)	11.5	32	45
Permissible let-through current of the fuses	kA	8	17	17	30 ⁴⁾	30 ⁴⁾
Maximum permissible let-through I^2t value	kA ² s	55	223	223	1000	1000
Switching capacity (infeed from top or bottom)						
At 400 V AC Breaking current I_c (p.f. = 0.35)	A (rms value)	500	1000	1280	2000	3200
Rated operational current I_e at AC-21A, AC-22A, AC-23A	A	63	125	160	250	400
Motor switching capacity AC-23A	kW	30	65	80	132	200
At 500 V AC Breaking current I_c (p.f. = 0.35)	A (rms value)	500	1000	1280	2000	3200
Rated operational current I_e at AC-21A, AC-22A, AC-23A	A	63	125	160	250	400
Motor switching capacity AC-23A	kW	40	90	110	185	280
At 690 V AC Breaking current I_c (p.f. = 0.35)	A (rms value)	500	1000	1280	2000	3200
Rated operational current I_e at AC-21A, AC-22A, AC-23A	A	63	125	160	250	400
Motor switching capacity AC-23A	kW	50	110	150	220	375
At 440 V DC (3 conducting paths series-connected) ⁴⁾ Breaking current I_c (L/R = 15 ms)	A	250	500	640	1000 ⁵⁾	1600
Rated operational current I_e at DC-23A	A	63	125	160	250 ⁶⁾	400
Rated short-time current (1 s current)	kA (rms value)	2.5	3.2	3.2	8	11
Permissible load Depending on the ambient temperature for open-type installation in control panels (e. g. 8NA1) in control cubicles or control racks at						
35 °C	A	63	125	160	250	400
40 °C	A	63	125	155	250	390
45 °C	A	63	125	150	250	380
50 °C	A	63	125	145	250	370
55 °C	A	63	125	140	240	360
Permissible ambient temperature	°C °C	-25 ... +55 for operation ³⁾ -50 ... +80 when stored				
Mechanical endurance	Operat- ing cycles	15000	15000	15000	12000	12000
Required operating torque	Nm	3	7.5	7.5	16	16
Degree of protection		IP00/IP20 (from the operator side, with fuse and terminal covers)				
Power loss of the switch disconnector at I_{th} (plus power loss of the fuses)	W	8.5	22	36	33	86
Main conductor connections Busbars, max. dimensions (w × t) Cable lug, max. conductor cross-section (stranded)	mm × mm mm ²	25 × 9 35	45 × 10 70	45 × 10 120	40 × 12 150	40 × 15 2 × 150 or 1 × 240

For footnotes see next page.

3KL, 3KM, 3NJ6 Switch Disconnectors with Fuses

3KM Switch Disconnectors with Fuses and Isolating Plug Connector up to 400 A

General data

Standards	IEC 60947-1, IEC 60947-3, VDE 0660 Part 107					
	Type	3KM50	3KM52	3KM53	3KM55	3KM57
Busbars, max. dimensions (w × t)	mm × mm	25 × 9	45 × 10	45 × 10	40 × 12	40 × 15
Tightening torque	Nm	6 ... 7.5	7 ... 10	18 ... 22	35 ... 45	35 ... 45
Terminal screws		M6	M6	M8	M10	M10
Protective conductor connections						
Flat bars	mm × mm	--	--	--	20 × 2.5	20 × 2.5
Cable lug, max. conductor cross-section (stranded)	mm ²	--	--	--	70	120
Auxiliary switch 1 NO + 1 NC (accessories)						
Max. number to be plugged		1	2	2	2	2
Rated operational current I_e at AC 50 Hz/60 Hz						
I_e /AC-12	A	10				
I_e /AC-15 at $U_e = 220$ V/230 V	A	6				
I_e /AC-15 at $U_e = 380$ V/400 V	A	4				
I_e /AC-15 at $U_e = 500$ V	A	2.5				
I_e /AC-15 at $U_e = 690$ V	A	1.2				
Rated operational current I_e at DC						
I_e /DC-13 at $U_e = 24$ V	A	10				
I_e /DC-13 at $U_e = 48$ V	A	4				
I_e /DC-13 at $U_e = 110$ V	A	1.2				
I_e /DC-13 at $U_e = 220$ V	A	0.4				
I_e /DC-13 at $U_e = 440$ V	A	0.2				
Connection						
Solid	mm ²	2 × (0.5 ... 1.5)				
Finely stranded with end sleeve	mm ²	2 × (1 ... 2.5)				
Weight						
Complete version	kg	1.936	2.960	2.960	7.160	7.450
Basic version	kg	1.820	2.600	2.600	6.147	6.443

1) Configuring note: max. permissible operating temperature for fuse blades 135 °C, for connections 100 °C.

2) 110 V (one conducting path).

3) 3ND1 switchgear protection fuse.

4) 220 V DC (L1 and L3 series-connected) or 110 V DC (one conducting path) at DC-23A.

5) At 440 V $L/R = 4$ ms, at 220 V $L/R = 15$ ms.

6) At 440 V DC-22A, at 220 V DC-23A.

Permissible mounting positions

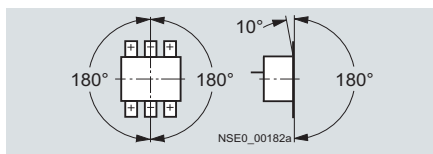

Mounting position for 3KM switch disconnectors

3KL, 3KM, 3NJ6 Switch Disconnectors with Fuses

3KM Switch Disconnectors with Fuses and Isolating Plug Connector up to 400 A

For snapping onto busbars

Dimensional drawings

3KM50, 63 A

with shaft and 8UC7 operating mechanism

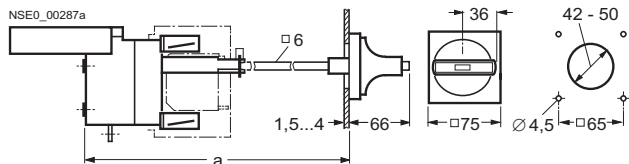

a	Shaft length
Max. 380	300; unchanged shaft from 8UC71
Min. 175	175 ₋₈₀ ; shortened shaft from 8UC71
175 < a < 380	a ₋₈₀

3KM50, 63 A

without operating mechanism, for BS fuses

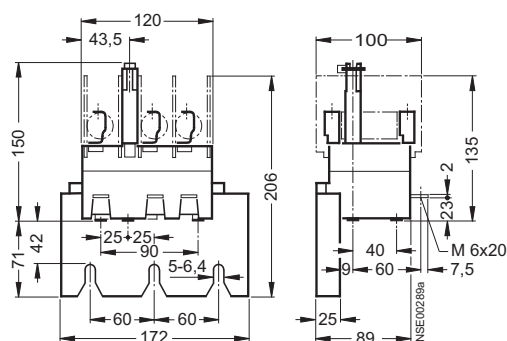

3KM52, 125 A

3KM53, 160 A

with shaft and 8UC7 operating mechanism

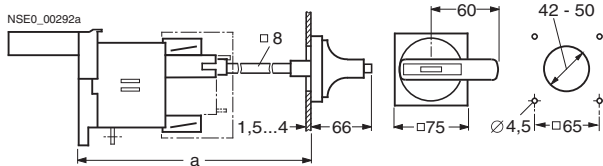

a	Shaft length
Max. 350	300; unchanged shaft from 8UC72
Min. 165	165 ₋₅₀ ; shortened shaft from 8UC72
165 < a < 350	a ₋₅₀

3KM50, 63 A

without operating mechanism, with lyre-shaped contacts

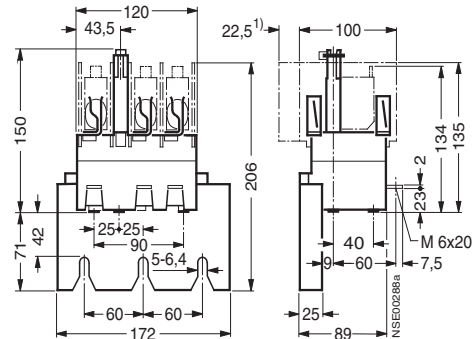

- 1) To be kept free of conductive parts. Not necessary when using lyre-shaped contacts or covers (accessories).

Drilling pattern and connector cutout

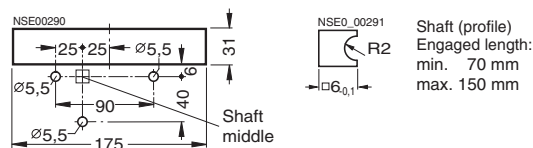

- 1) To be kept free of conductive parts. Not necessary when using lyre-shaped contacts (included in the scope of supply) or covers (accessory).

3KM52, 125 A

3KM53, 160 A

without operating mechanism, with lyre-shaped contacts (for further dimensions see 3KL52 and 3KL53)

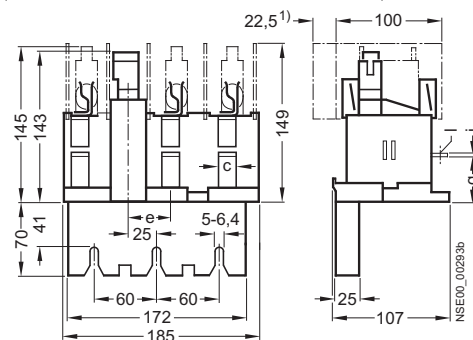

Type	c	e	g	i	l
3KM52	15	37	42	3	Ø 6.6
3KM53	20	39	39.5	3.5	Ø 9

- 1) To be kept free of conductive parts. Not necessary when using lyre-shaped contacts or covers (accessories).

3KL, 3KM, 3NJ6 Switch Disconnectors with Fuses

3KM Switch Disconnectors with Fuses and Isolating Plug Connector up to 400 A

For snapping onto busbars

3KM52, 125 A

3KM53, 160 A

without operating mechanism, for BS fuses

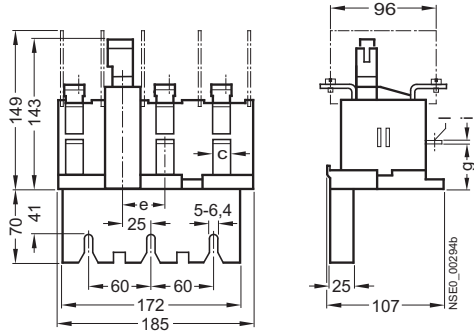

Drilling pattern and cut-out in the mounting plate for mounting 3KM52

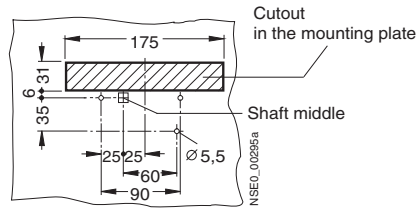

Type	c	e	g	i	l
3KM52	15	37	42	3	Ø 6.6
3KM53	20	39	39.5	3.5	Ø 9

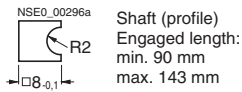

Shaft (profile)
Engaged length:
min. 90 mm
max. 143 mm

3KM55, 250 A

3KM57, 400 A

with shaft and 8UC7 operating mechanism

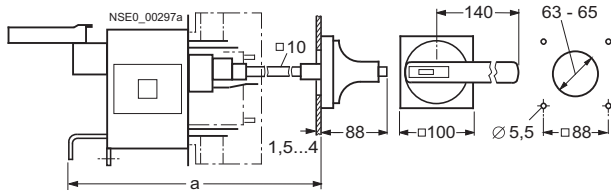

a	Shaft length
Max. 335	300; unchanged shaft from 8UC73
Min. 230	230 ₃₅ ; shortened shaft from 8UC73
230 < a < 335	a ₃₅

3KM55, 250 A

3KM57, 400 A

without shaft, without operating mechanism, with lyre-shaped contacts (further dimensions see 3KL55)

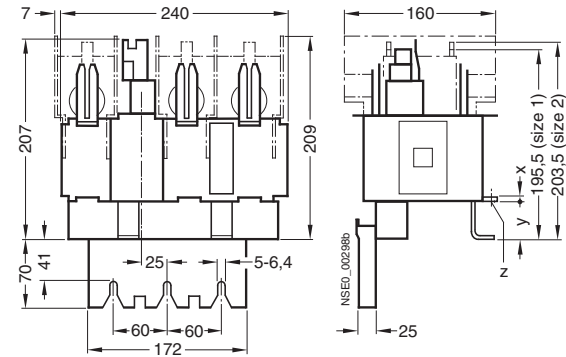

Type	x	y	z
3KM55	4	40	M 10 x 30
3KM57	6	38	M 10 x 36

3KX3 508-0AA busbar support

for bars 30 mm x 5 mm

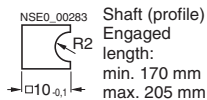
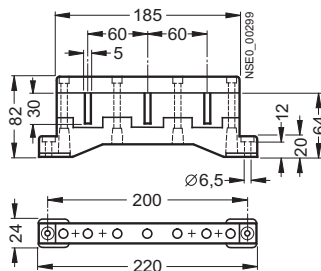

Shaft (profile)
Engaged length:
min. 170 mm
max. 205 mm

Drilling pattern and cut-out in the mounting plate for mounting 3KM55 and 3KM57

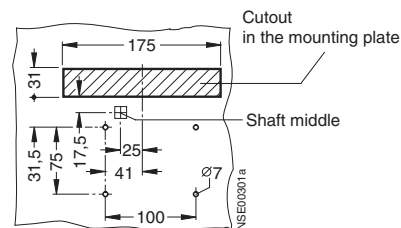

3KL, 3KM, 3NJ6 Switch Disconnectors with Fuses

3KM Switch Disconnectors with Fuses and Isolating Plug Connector up to 400 A

For snapping onto busbars

Cut-outs for **3K . 50, 3KA51**
with 3KX3 516-... rear manual
operating mechanism

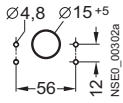

Cut-outs for **3K . 52, 3K . 53**
with 3KX3 526-.../3KX3 536-... rear manual operating
mechanism

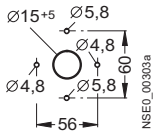

Cut-outs for **3K . 55, 3K . 57, 3K . 58**
with 3KX3 556-... rear manual operating mechanism

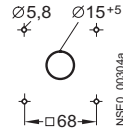

Schematics

Internal circuit diagram for 3KM

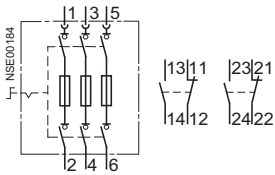

(for 3KM50 and 3KM51, only one auxiliary switch possible)

3KL, 3KM, 3NJ6 Switch Disconnectors with Fuses

8UC Door-Coupling Rotary Operating Mechanisms

For 3K switch disconnectors

Overview



4 standard sizes of operating mechanisms are available:

Size	Rated torque ¹⁾ Nm	Shaft profile mm x mm	Masking plate mm x mm
1	4	6 x 6	75 x 75
2	9	8 x 8	75 x 75
3	25	10 x 10 or 12 x 12	100 x 100
4	40/55 ²⁾	12 x 12	100 x 100

1) Operating mechanisms tested with triple torque (VDE 0660 Part 107). They are therefore qualified for use in all controls, especially for disconnectors.

2) Operation with two hands.

Design

Operating mechanisms consist of a masking plate with handle including seal and fixing screws for door installation and of a shaft coupling, extension shaft (300 mm) and coupling driver to be mounted onto the switch shaft. Operating mechanisms for 3KA/3KL/3KM switch disconnectors do not have a shaft coupling since the extension shaft is fitted directly into the switch. Extension shafts with a length of 600 mm are available.

Masking plates are light-gray with black inscription, handles are ti-grey. For EMERGENCY-STOP switches, a yellow indicator plate with black inscription is mounted; the handles are red. The retractable locking device (light green basic) for padlocks is integrated in the handle.

The door interlock on the rotary operating mechanisms is suitable for padlocks with shackle diameters of 4.5 mm to 8.5 mm (locks according to DIN 7465).

Up to three locks with shackle diameter of 8.5 mm or up to five locks with shackle diameter of 6 mm can be fitted.

Mounting instructions are included in the scope of supply. Operating instructions containing hints on activation or modification of interlocking conditions are available by quoting Order No. 8ZX1012-0UC60-1AA1 or can be downloaded. The Internet address is: <http://www.siemens.com/lowvoltage>

8UC7 door-coupling rotary operating mechanisms are capable of taking up a radial eccentricity of max. 5 mm between the actuating shaft of the switching device and the operating mechanism. Supporting the extension shaft is recommended with greater tolerances. ± 5 mm can be compensated in axial direction. The distance between the door hinge and the center of rotary operating mechanism must not be less than 100 mm.

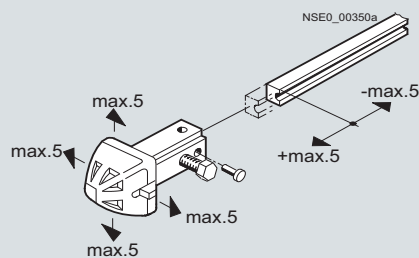

Permissible radial eccentricity and axial tolerance compensation

Switch position

In order to ensure compliance with locking and interlocking conditions, the controls and operating mechanisms must be installed such that, with two-position switches the "0" position lies at 9 o'clock and the "I" position at 12 o'clock.

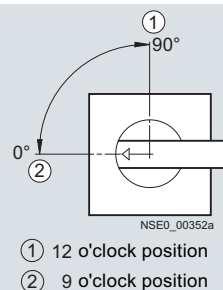

Positions for two-position switches with 90° operating angle

Non-interchangeability

In order to ensure that, when installing switches and door-coupling operating mechanisms, all components - the actuating shaft, shaft coupling, extension shaft, coupling driver and door-coupling operating mechanism - are assembled in the correct position with respect to one another, all the above-mentioned parts are provided with non-interchangeability features (groove and lug).

For controls whose non-interchangeability groove is not at 3 o'clock in the "0" position or switches that can be installed at an angle of 90° to the left or right, the non-interchangeability groove can be repositioned.

When the switch and the door coupling are fitted, the rivet in the shaft coupling or coupling driver is moved accordingly. All door-coupling rotary operating mechanisms listed in this catalog are supplied with the "0" position of the mechanism at 9 o'clock and the "I" position at 12 o'clock. This refers to controls to be installed in the normal mounting position.

In operation and when performing maintenance, these non-interchangeability features preclude the risk of accidents caused by incorrect handling or incorrect switching operations.

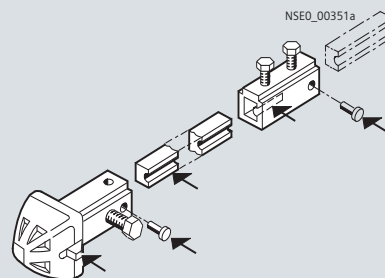

Non-interchangeability features (see arrows) of rotary operating mechanisms

3KL, 3KM, 3NJ6 Switch Disconnectors with Fuses

8UC Door-Coupling Rotary Operating Mechanisms

For 3K switch disconnectors

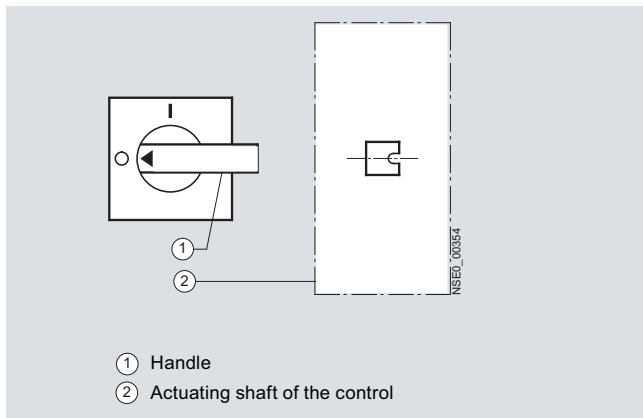

Correlation between handle of rotary operating mechanism and actuating shaft

Stops

To prevent damage to smaller switches, an excessive manual operating torque can be absorbed by stops fitted on the inside of sizes 1 and 2 rotary operating mechanisms. These stops are supplied loose with the operating mechanisms and can be fitted as required after consulting the operating instructions.

Stops are fitted at the factory to size 1 and 2 operating mechanisms with a 90° operating angle (exception: 3V. circuit breakers).

Pull-out strength

The pull-out strength of interlocked operating mechanisms, e. g. pulling off the shaft or destruction of the operating mechanism, amounts to ≥ 800 N when the pulling force acts directly onto the operating mechanism in direction of shaft.

Function

The basic (standard) versions of the rotary operating mechanisms comply with the following interlocking conditions:

- Operating mechanism and switch in "0" (OFF) position:
The control cabinet door can be opened, the operating mechanism is uncoupled and the handle of the rotary operating mechanism engages.
If padlocks are fitted with the control cabinet door closed and the actuator is set to "0", the operating mechanism (and switch) cannot be actuated and the door cannot be opened.
- Operating mechanism and switch in "I" (ON) position:
The control cabinet door cannot be opened in this position. The interlocking mechanism can, however, be overridden by trained personnel (pressing of a concealed latch with a screwdriver or the like), thus making it possible to open the control cabinet door in the "I" position of the control for performing checks. The handle engages in the "I" setting with the door open. In the "I" position it is not possible to fit padlocks to lock the operating mechanisms.

Other interlocking conditions

- If no door interlock is required, the user can remove the door interlocking plate of the rotary operating mechanism after consulting the operating instructions.
- If provision is to be made for fitting padlocks to the rotary operating mechanism in the "I" position as well, the user can easily achieve this after consulting the operating instructions by knocking out a lug. Such a measure must not, however, be implemented with EMERGENCY-STOP rotary operating mechanisms. If padlocks are fitted in the "I" position of the rotary operating mechanism, the mechanism cannot be actuated, the control cabinet door cannot be opened and the operating mechanism cannot be overridden in order to open the door.
- If necessary the rotary operating mechanisms can also be locked in the 90°, 180° position etc. as well as in the "0" position. The measures previously listed in item 2 under "Other Interlocking Conditions" must be carried out by the user.
- In the case of rotary operating mechanisms for switches without "0" position, such as stepping switches without "0" position, the door interlocking plate is removed.

3KL, 3KM, 3NJ6 Switch Disconnectors with Fuses 8UC Door-Coupling Rotary Operating Mechanisms

For 3K switch disconnectors

Dimensional drawings

8UC71 and 8UC72 door-coupling rotary operating mechanisms, sizes 1 and 2

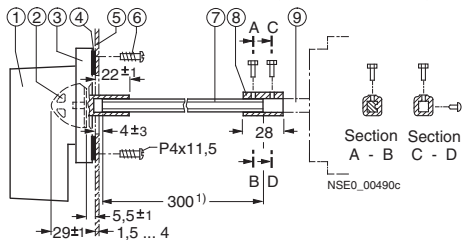

With extension shaft

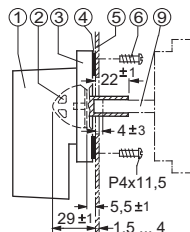

Without extension shaft

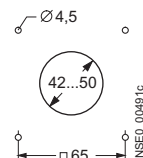

Door cut-out with mounting holes

- ① Selector switch
- ② Coupling driver
- ③ Masking plate
- ④ Seal
- ⑤ Door
- ⑥ Fixing screw, 4 units
- ⑦ Extension shaft
- ⑧ Shaft coupling
- ⑨ Actuating shaft of the control

8UC73 to 8UC74 door-coupling rotary operating mechanisms, sizes 3 and 4

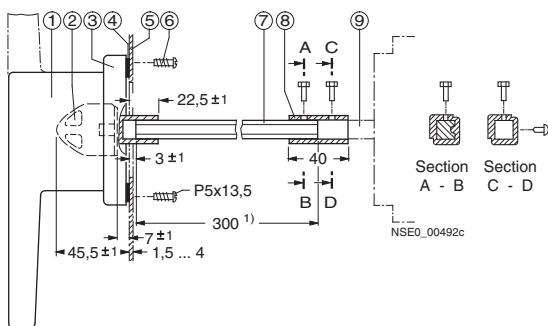

With extension shaft

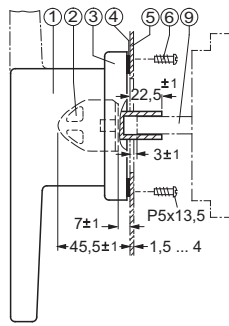

Without extension shaft

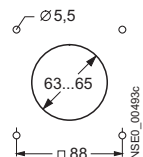

Door cut-out with mounting holes

- ① Handle or twin handle
- ② Coupling driver
- ③ Masking plate
- ④ Seal
- ⑤ Door
- ⑥ Fixing screw, 4 units
- ⑦ Extension shaft
- ⑧ Shaft coupling
- ⑨ Actuating shaft of the control

1) Length of extension shaft can be cut to fit mounting depth. Extension shaft also available in 600 mm length.

3KL, 3KM, 3NJ6 Switch Disconnectors with Fuses 8UC Door-Coupling Rotary Operating Mechanisms

Individual parts

Dimensional drawings

8UC60 coupling driver

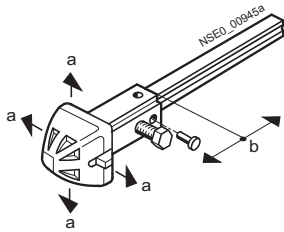

Coupling drivers	a	b	Shaft length
With tolerance compensation	+5	±5	x
Without tolerance compensation	+1.5	±2.5	x + 23.5

8UC92 53 shaft coupling

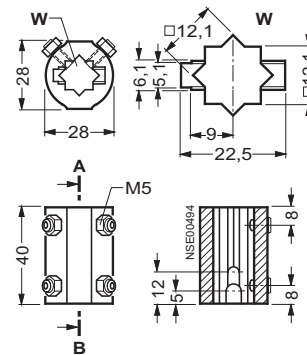

8UC71, size 1

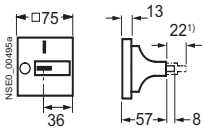

8UC72, size 2

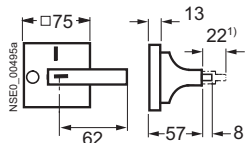

8UC73, size 3

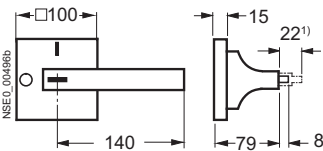

8UC74, size 4

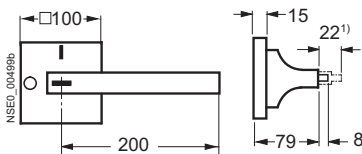

Handles with masking plate, sizes 1 to 4

1) Padlock feature of handle pulled out.

3KL, 3KM, 3NJ6 Switch Disconnectors with Fuses 8UC Door-Coupling Rotary Operating Mechanisms

Operating mechanisms for fixed mounting

Dimensional drawings

8UC93 54, 3KX3 516-1AA operating mechanisms for fixed mounting
Size 1

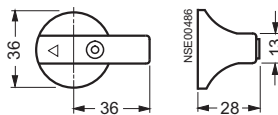

8UC93 60 to 8UC93 63, 3KX3 536-1AA operating mechanisms for fixed mounting
Size 2

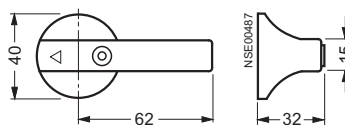

8UC93 65 to 8UC93 75, 3KX3 176-1E operating mechanisms for fixed mounting
Sizes 3 and 4

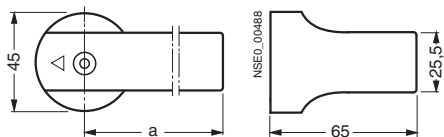

Size	Shape	a
3		140
4		200

8UC93 81 to 8UC93 82, 3KX3 616-1A operating mechanisms for fixed mounting
Size 5

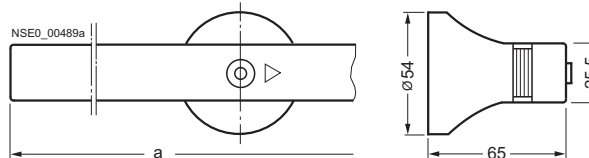

Size	Shape	a
5		280

3KL, 3KM, 3NJ6 Switch Disconnectors with Fuses

3NJ6 In-Line Switch Disconnectors with Fuses up to 630 A

3NJ62 switch disconnectors with fuses
General data

Overview



3NJ62 switch disconnector with fuses

All key product features at a glance

- Type-tested according to IEC 60947-3, EN 60947-3
- Voltage levels up to 690 V AC
- 160 A to 630 A for LV HRC fuse links, according to IEC 60269-1/EN 60269-1
- 3-pole versions available
- 185 mm phase center distance of plug-in contacts
- Developed for switchgear assemblies in plug-in design
- Horizontal or vertical mounting position
- Front panel locked in ON position
- Degree of protection IP41

Overview of components and accessory parts

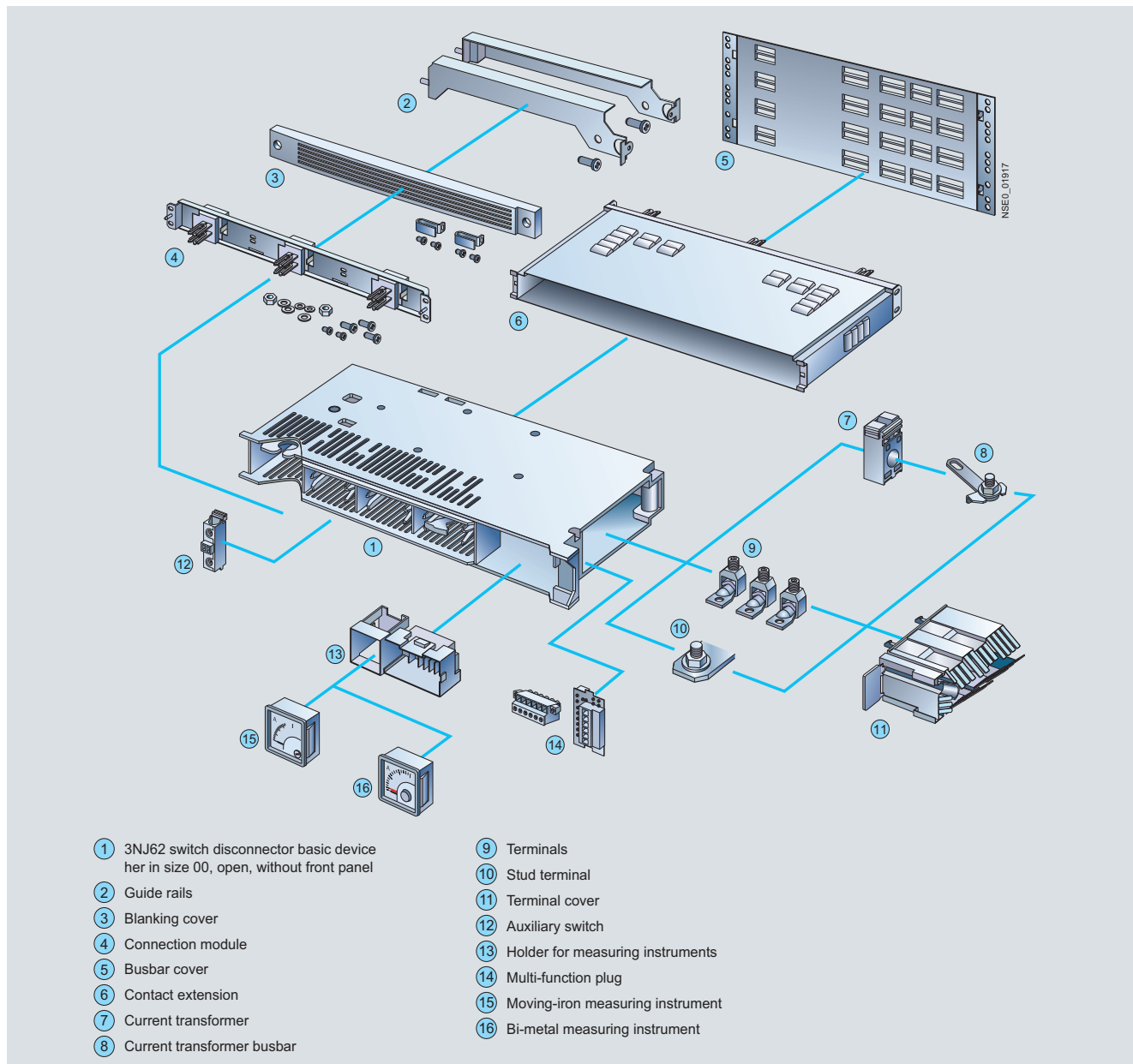

3KL, 3KM, 3NJ6 Switch Disconnectors with Fuses

3NJ6 In-Line Switch Disconnectors with Fuses up to 630 A

3NJ62 switch disconnectors with fuses General data

Design

Compact and modular design

All sizes fit busbar systems with a 185-mm center-to-center spacing, have the same width and depth, as well as a uniform 50-mm grid with regard to mounting height (50, 100 and 200 mm). This enables the setup of an in-line disconnector panel with any combinations of different sizes.

Easy subsequent replacement of the in-line disconnectors of different sizes. Furthermore, the user-friendly hinged handle is retractable in both the ON and the OFF state, so that the compact design is retained in both switch positions.

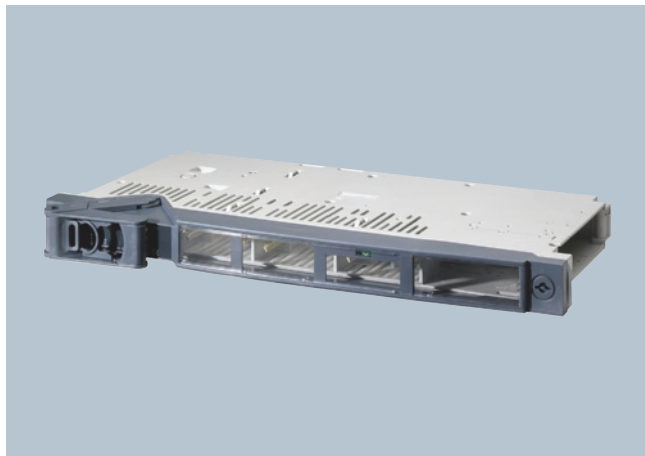

Size NH 00, 160 A



Size NH 2, 400 A, NH 3, 630 A

Overview of current transformer types and current transformer busbar sets

Size NH 00	NH 00 with 1 current transformer	NH 00 with 3 current transformers	NH 00 with 4 current transformers
Current transformer busbar set, \varnothing 21 mm, Order No.	3NJ69 20-3DB00	3NJ69 20-3DC00	3NJ69 20-3DD00
Current transformer busbar set, \varnothing 14 mm, Order No.	3NJ69 20-3DE00	3NJ69 20-3DF00	3NJ69 20-3DG00
Size NH 1	NH 1 with 1 current transformer	NH 1 with 3 current transformers	NH 1 with 4 current transformers
Current transformer busbar set, \varnothing 21 mm, Order No.	3NJ69 30-3DB00	3NJ69 30-3DC00	3NJ69 30-3DD00
Size NH 2/NH 3	NH 2/NH 3 with 1 current transformer	NH 2/NH 3 with 3 current transformers	NH 2/NH 3 with 4 current transformers
No current transformer busbar set required			

Connection methods

All plug-in switch disconnectors supplied for cable lug connection as standard.

Size	Cable lug connection	Terminal connection
NH 00	1 x (10 mm ² ... 95 mm ²) 2 x (16 mm ² ... 70 mm ²)	1 x (10 mm ² ... 95 mm ²)
NH 1	1 x (25 mm ² ... 240 mm ²) 2 x (25 mm ² ... 185 mm ²)	1 x (16 mm ² ... 300 mm ²)
NH 2/NH 3	1 x (25 mm ² ... 300 mm ²) 2 x (25 mm ² ... 240 mm ²)	2 x (16 mm ² ... 300 mm ²)

3KL, 3KM, 3NJ6 Switch Disconnectors with Fuses

3NJ6 In-Line Switch Disconnectors with Fuses up to 630 A

3NJ62 switch disconnectors with fuses
General data

Ammeters

An ammeter according to DIN 43718 with dimensions 48 mm x 48 mm can be used to measure the current. It can be a moving-iron measuring instrument or a bi-metal measuring instrument.

A holder for the ammeter must be ordered as a separate accessory part.

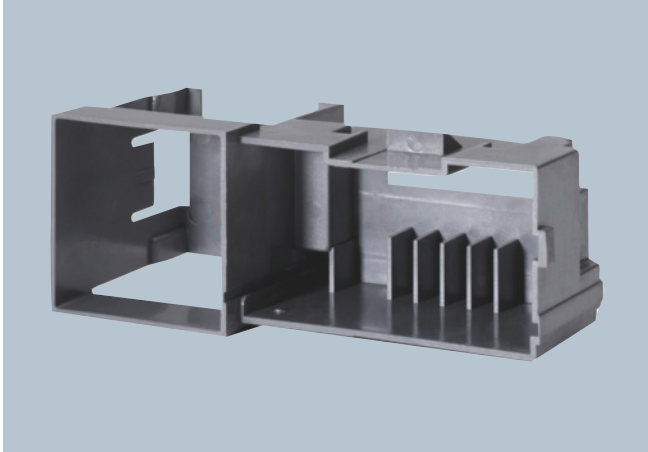

Holder for ammeters



Ammeter (moving-iron measuring instrument, left) and (bi-metal measuring instrument, right)

3KL, 3KM, 3NJ6 Switch Disconnectors with Fuses

3NJ6 In-Line Switch Disconnectors with Fuses up to 630 A

3NJ62 switch disconnectors with fuses

General data

Function

Mode of operation

Operation

The plug-in switch disconnectors are fitted with a snap-action mechanism and are switched by turning the handle approx. 45°. Once actuated, the handle is folded against the front panel in the ON or OFF position for safety reasons.

The switch position is clearly shown by the indicator in the inspection window of the in-line disconnector (On "I" = red, OFF "O" = green). The switch position indicator is mechanically linked to the moving switching contacts.

Voltage test

In the event of a voltage test on the fuse links, the transparent insert in the front panel is opened.

Switch position

OFF

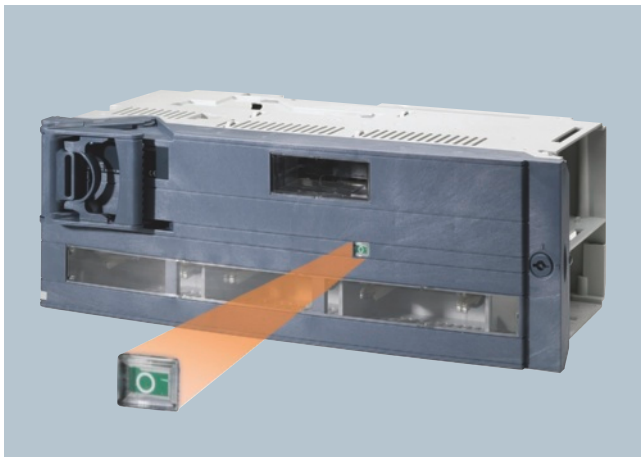

"OFF" position, display



"OFF" position, operating lever in off position

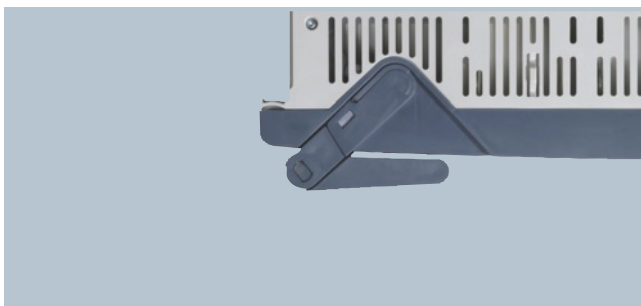

"OFF" position, operating lever in end position

Protection against electric shock

The switch disconnectors are type-tested according to IEC 60947-3 and have degree of protection IP41 in the operating state.

The special interlocking mechanism on the handle ensures that the in-line disconnector must be switched off before it is possible to open the cover and remove the fuse. A switchgear key according to DIN 43668 is also required to open the cover. In the OFF position, the handle can also be padlocked to protect against unintentional restarting.

The disconnection during the switching operation (snap-action mechanism) is implemented before and after the fuse link. This ensures that, if power is supplied over the busbars or over the cable connecting side, the fuse links are in a dead state when switched off.

ON

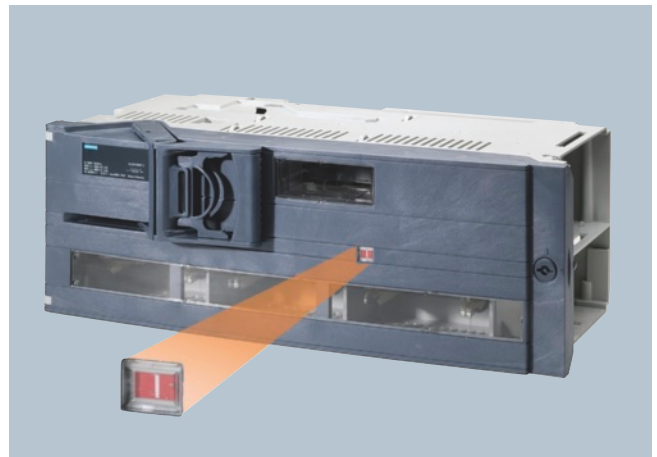

"ON" position, display

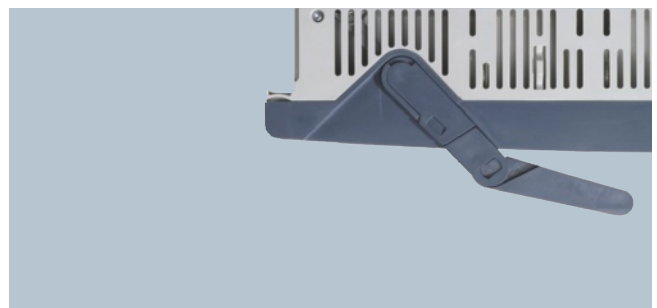

"ON" position, operating lever in off position



"ON" position, operating lever in end position

3KL, 3KM, 3NJ6 Switch Disconnectors with Fuses

3NJ6 In-Line Switch Disconnectors with Fuses up to 630 A

3NJ62 switch disconnectors with fuses
General data

Configuration

Installation data

3NJ62 switch disconnectors	Rated current	Size	Height requirements of in-line disconnectors
Type	A		mm
3NJ62 0	160	00	50
3NJ62 1	250	1	100
3NJ62 2	400	2	200
3NJ62 3	630	3	200

Further built-in components	Designation	Height requirements
Type		mm
3NJ69 00-4CB00	Blanking covers for empty compartments/connection module	50
3NJ69 15-3BA00	Connection module 400 A for device compartment (without front panel)	50

Rated currents

- Rated current of device sizes = $0.8 \times I_N$ of the biggest fuse link
- For summation current of all feeders in the SIVACON cubicle ≤ 2000 A.

Device size	Fuses I_N	Rated current = $0.8 \times I_N$
	A	A
00	160	125
	125	100
	80	64
1	250	200
	224	180
	125	100
2	400	320
	355	284
	315	252
3	630	504
	500	400
	400	320

Configuration rules

Configuration rules for ventilated SIVACON cubicles with 3NJ6 switch disconnectors with fuses

- For the fully equipped cubicle, the rated diversity factor according to IEC 60439-1 applies. Failure to comply with these instructions may lead to premature ageing of fuses and uncontrolled tripping as a result of local overheating.
- All data refer to ambient temperatures of the control cabinet of 35 °C in 24 h-average value.

3KL, 3KM, 3NJ6 Switch Disconnectors with Fuses

3NJ6 In-Line Switch Disconnectors with Fuses up to 630 A

3NJ62 switch disconnectors with fuses

General data

Rated diversity factor according to IEC 60439-1

Number of main circuits	Rated diversity factor
2 and 3	0.9
4 and 5	0.8
6 to 9	0.7
10 and more	0.6

Conversion factors for other ambient temperatures

Ambient temperature of the system	°C	20	25	30	35	40	45	50	55
Conversion factor		1.1	1.07	1.04	1.00	0.95	0.9	0.85	0.8

Rated current of fuse links

Summation current of all feeders in the cubicle $\leq 2000 \text{ A} = 0.8 \times I_N$ of fuse

Permissible exceptions: summation current of all feeders in cubicle $\leq 1500 \text{ A}$
 Size 00 to 2 = $0.90 \times I_N$
 Size 3 = $0.85 \times I_N$
 Group formation is not permitted in this case. Each device, sizes 00 and 1 must be assigned a 50 mm high blanking cover.

In-line disconnector arrangement

Equipment in the cubicle, from top to bottom, decreasing from size 3 to size 00.

In-line disconnectors of size 2 > 280 A uninterrupted load current
 Disconnectors of size 3 > 440 A uninterrupted load current should - where possible - be distributed among different cubicles.

Blanking covers

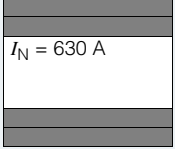
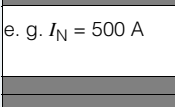
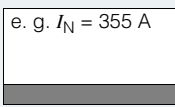
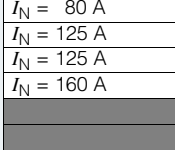
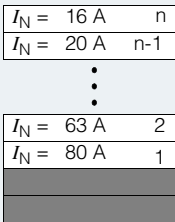
	Permissible current	Total covered height to be allocated	Arrangement of in-line disconnectors + respective blanking covers
With ventilation slots, 50 mm high	(uninterrupted load current at 35 °C system ambient temperature)	(for recommended arrangement of blanking covers, see right)	
In-line disconnectors size 3 (group formation not permissible)	$\geq 440 \text{ A}$ to 500 A of single device	200 mm = 4 units per in-line disconnector	 $I_N = 630 \text{ A}$ $I_N \times 0.8 = 500 \text{ A}$ = permissible uninterrupted load current
	< 440 A of single device	150 mm = 3 units per in-line disconnector	 e. g. $I_N = 500 \text{ A}$ $I_N \times 0.8 = 400 \text{ A}$ = permissible uninterrupted load current
In-line disconnectors size 2 (group formation not permissible)	$\leq 320 \text{ A}$ of single device	50 mm = 1 unit per in-line disconnector	 e. g. $I_N = 355 \text{ A}$ $I_N \times 0.8 = 284 \text{ A}$ = permissible uninterrupted load current
Groups of in-line disconnectors sizes 00 and 1	$\leq 400 \text{ A}$ = summation current of fuse links, group $\times 0.8$	100 mm = 2 units per group	 $I_N = 80 \text{ A}$ $I_N = 125 \text{ A}$ $I_N = 125 \text{ A}$ $I_N = 160 \text{ A}$ Total $I_N \times 0.8 \leq 400 \text{ A}$ = permissible uninterrupted load current
Any sized groups of in-line disconnectors of size 00	$\leq 64 \text{ A}$ of single device	100 mm = 2 units per group In combination with size 2 and 3 in a panel are the rated currents size 2 = 280 A and size 3 = 440 A. Devices with size 2 and 3 must be allocated blanking covers (see above).	 $I_N = 16 \text{ A}$ n $I_N = 20 \text{ A}$ n-1 ⋮ $I_N = 63 \text{ A}$ 2 $I_N = 80 \text{ A}$ 1 (Total 1 to I_N) $\times \alpha$ = permissible uninterrupted load current α = rated diversity factor n = 4 and $5\alpha = 0.8$ n = 6 to 9 $\alpha = 0.7$ n ≥ 10 $\alpha = 0.6$

3KL, 3KM, 3NJ6 Switch Disconnectors with Fuses 3NJ6 In-Line Switch Disconnectors with Fuses up to 630 A

3NJ62 switch disconnectors with fuses General data

Assignment of blanking covers with 50 mm high ventilation slots

Group		Single device										
Size 00	Size 1	Size 2	Size 3									
Summation current of group ≤ 500 A	Summation current of group = 500 A	Summation current of group = 500 A	Summation current of group = 500 A									
Permissible uninterrupted load current ≤ 400 A	Permissible uninterrupted load current ≤ 40 A	Permissible uninterrupted load current of single device ≤ 320 A	Permissible uninterrupted load current of single device ≤ 440 A									
<table border="1"> <tr><td>$I_N = 80\text{ A}$</td></tr> <tr><td>$I_N = 125\text{ A}$</td></tr> <tr><td>$I_N = 125\text{ A}$</td></tr> <tr><td>$I_N = 160\text{ A}$</td></tr> </table>	$I_N = 80\text{ A}$	$I_N = 125\text{ A}$	$I_N = 125\text{ A}$	$I_N = 160\text{ A}$	<table border="1"> <tr><td>$I_N = 250\text{ A}$</td></tr> <tr><td>$I_N = 250\text{ A}$</td></tr> </table>	$I_N = 250\text{ A}$	$I_N = 250\text{ A}$	<table border="1"> <tr><td>e. g. $I_N = 355\text{ A}$</td></tr> </table>	e. g. $I_N = 355\text{ A}$	<table border="1"> <tr><td>e. g. $I_N = 500\text{ A}$</td></tr> <tr><td>$I_N = 630\text{ A}$</td></tr> </table>	e. g. $I_N = 500\text{ A}$	$I_N = 630\text{ A}$
$I_N = 80\text{ A}$												
$I_N = 125\text{ A}$												
$I_N = 125\text{ A}$												
$I_N = 160\text{ A}$												
$I_N = 250\text{ A}$												
$I_N = 250\text{ A}$												
e. g. $I_N = 355\text{ A}$												
e. g. $I_N = 500\text{ A}$												
$I_N = 630\text{ A}$												
Summation current of group 490 A x 0.8 = 392 A	Summation current of group 500 A x 0.8 = 400 A	0.8 x $I_N = 280\text{ A}$	0.8 x $I_N = 400\text{ A}$									
2 blanking covers/group	2 blanking covers/group	1 blanking cover/device	3 blanking covers/device									
			440 A > 400 A > 320 A = 500 A									
			4 blanking covers/device									

Group	Permissible uninterrupted load current of single device ≤ 64 A	Group	Example:																			
Size 00	Size 00 and 1	Group size 00 and sizes 2 and 3	When combining size 00 with $I_N 80\text{ A}$ with other sizes, in the case of sizes 2 to 3, the rated currents must be reduced to $0.7 \times I_N$:																			
Size 00 with $I_N \leq 80\text{ A}$	Any group size, up to 33 in-line disconnectors/panel	<table border="1"> <tr><td>$I_N = 40\text{ A}$</td></tr> <tr><td>$I_N = 100\text{ A}$</td></tr> <tr><td>$I_N = 100\text{ A}$</td></tr> <tr><td>$I_N = 250\text{ A}$</td></tr> </table>	$I_N = 40\text{ A}$	$I_N = 100\text{ A}$	$I_N = 100\text{ A}$	$I_N = 250\text{ A}$	<table border="1"> <tr><td>$I_N = 20\text{ A}$</td></tr> <tr><td>$I_N = 32\text{ A}$</td></tr> <tr><td>$I_N = 32\text{ A}$</td></tr> <tr><td>$I_N = 40\text{ A}$</td></tr> <tr><td>$I_N = 40\text{ A}$</td></tr> <tr><td>$I_N = 50\text{ A}$</td></tr> <tr><td>$I_N = 50\text{ A}$</td></tr> <tr><td>$I_N = 80\text{ A}$</td></tr> <tr><td>$I_N = 80\text{ A}$</td></tr> <tr><td>$I_N = 80\text{ A}$</td></tr> <tr><td>$I_N = 80\text{ A}$</td></tr> <tr><td>$I_N = 80\text{ A}$</td></tr> <tr><td>$I_N = 80\text{ A}$</td></tr> <tr><td>$I_N = 80\text{ A}$</td></tr> <tr><td>$I_N = 80\text{ A}$</td></tr> </table>	$I_N = 20\text{ A}$	$I_N = 32\text{ A}$	$I_N = 32\text{ A}$	$I_N = 40\text{ A}$	$I_N = 40\text{ A}$	$I_N = 50\text{ A}$	$I_N = 50\text{ A}$	$I_N = 80\text{ A}$	$I_N = 80\text{ A}$	$I_N = 80\text{ A}$	$I_N = 80\text{ A}$	$I_N = 80\text{ A}$	$I_N = 80\text{ A}$	$I_N = 80\text{ A}$	$I_N = 80\text{ A}$
$I_N = 40\text{ A}$																						
$I_N = 100\text{ A}$																						
$I_N = 100\text{ A}$																						
$I_N = 250\text{ A}$																						
$I_N = 20\text{ A}$																						
$I_N = 32\text{ A}$																						
$I_N = 32\text{ A}$																						
$I_N = 40\text{ A}$																						
$I_N = 40\text{ A}$																						
$I_N = 50\text{ A}$																						
$I_N = 50\text{ A}$																						
$I_N = 80\text{ A}$																						
$I_N = 80\text{ A}$																						
$I_N = 80\text{ A}$																						
$I_N = 80\text{ A}$																						
$I_N = 80\text{ A}$																						
$I_N = 80\text{ A}$																						
$I_N = 80\text{ A}$																						
$I_N = 80\text{ A}$																						
<table border="1"> <tr><td>$I_N = 20\text{ A}$</td></tr> <tr><td>$I_N = 32\text{ A}$</td></tr> <tr><td>$I_N = 32\text{ A}$</td></tr> <tr><td>$I_N = 40\text{ A}$</td></tr> <tr><td>$I_N = 40\text{ A}$</td></tr> <tr><td>$I_N = 50\text{ A}$</td></tr> <tr><td>$I_N = 50\text{ A}$</td></tr> <tr><td>$I_N = 80\text{ A}$</td></tr> <tr><td>$I_N = 80\text{ A}$</td></tr> <tr><td>$I_N = 80\text{ A}$</td></tr> <tr><td>$I_N = 80\text{ A}$</td></tr> <tr><td>$I_N = 80\text{ A}$</td></tr> <tr><td>$I_N = 80\text{ A}$</td></tr> <tr><td>$I_N = 80\text{ A}$</td></tr> </table>	$I_N = 20\text{ A}$	$I_N = 32\text{ A}$	$I_N = 32\text{ A}$	$I_N = 40\text{ A}$	$I_N = 40\text{ A}$	$I_N = 50\text{ A}$	$I_N = 50\text{ A}$	$I_N = 80\text{ A}$	$I_N = 80\text{ A}$	$I_N = 80\text{ A}$	$I_N = 80\text{ A}$	$I_N = 80\text{ A}$	$I_N = 80\text{ A}$	$I_N = 80\text{ A}$	16 A 26 A 26 A 32 A 32 A 40 A 40 A 40 A 64 A 64 A 64 A 64 A 64 A 64 A 64 A 64 A 2 blanking covers/group	Summation current of group 490 A x 0.8 = 392 A 2 blanking covers/group	<p>Please observe assignment of blanking covers for devices of sizes 1 to 3 (see adjacent example of a panel not fully equipped)!</p>					
$I_N = 20\text{ A}$																						
$I_N = 32\text{ A}$																						
$I_N = 32\text{ A}$																						
$I_N = 40\text{ A}$																						
$I_N = 40\text{ A}$																						
$I_N = 50\text{ A}$																						
$I_N = 50\text{ A}$																						
$I_N = 80\text{ A}$																						
$I_N = 80\text{ A}$																						
$I_N = 80\text{ A}$																						
$I_N = 80\text{ A}$																						
$I_N = 80\text{ A}$																						
$I_N = 80\text{ A}$																						
$I_N = 80\text{ A}$																						
		<table border="1"> <tr><td>Size 2</td></tr> <tr><td>$I_N = 400\text{ A}$</td></tr> </table>	Size 2	$I_N = 400\text{ A}$	Rated current: 280 A																	
Size 2																						
$I_N = 400\text{ A}$																						
		<table border="1"> <tr><td>Size 3</td></tr> <tr><td>$I_N = 630\text{ A}$</td></tr> </table>	Size 3	$I_N = 630\text{ A}$	Rated current: 440 A																	
Size 3																						
$I_N = 630\text{ A}$																						

3KL, 3KM, 3NJ6 Switch Disconnectors with Fuses

3NJ6 In-Line Switch Disconnectors with Fuses up to 630 A

3NJ62 switch disconnectors with fuses

General data

Technical specifications

Standards	EN / IEC 60947-3												
Type 3NJ62...- For LV HRC fuse links, size	03-1 00 and 000	03-3 00 and 000	13-1 1	13-3 1	23-1 2 and 1	23-3 2 and 1	33-1 3 and 2	33-3 3 and 2					
Switching capacity	S	H	S	H	S	H	S	H					
Rated operational voltage U_e • At 50/60 Hz rated frequency	V AC	500	690	500	690	690	690	690	690	500	690	500	690
Rated operational current I_e • For fuse links acc. to IEC 60269	A	160	125	160	125	250	250	400	400	630	500	630	500
Utilization categories		AC22B		AC23B		AC22B		AC23B		AC22B		AC23B	
Rated conditional short-circuit current • Short-circuit strength (rms value)	kA	100		100		100	100	100	100	100		100	
• Short-circuit making capacity (rms value)	kA	55		66		55	66	55	66	55		66	
Rated making capacity • P.f. = 0.65	A	480	375	--	--	750	--	1200	--	1890	1500	--	--
• P.f. = 0.45	A	--	--	--	--	--	--	--	--	--	--	--	--
• P.f. = 0.35	A	--	--	1600	1250	--	2500	--	4000	--	--	6300	5000
Rated breaking capacity • P.f. = 0.65	A	480	375	--	--	750	--	1200	--	1890	1500	--	--
• P.f. = 0.45	A	--	--	--	--	--	--	--	--	--	--	--	--
• P.f. = 0.35	A	--	--	1200	1000	--	2000	--	3200	--	--	5040	4000
Endurance • Operating cycles Total		1600				1600		1000		1000			
• Operating cycles Electrical (690 V, p.f. = 0.65)		200				200		200		200			
Power loss Without fuse links	W	43				78		158		357			
Rated insulation voltage U_i	V	1000											
Rated peak withstand voltage U_{imp}	V	8000											
Permissible ambient temperature	°C	-5 ... +55											
Permissible mounting positions		Horizontal and vertical with bottom connection											
Degree of protection (in operating state)		IP41											
Main conductor connections													
Cable lug connection													
• Conductor cross-section (Al/Cu, solid or stranded) acc. to DIN 46235 (Cu) and DIN 46239 (Al)	mm ²	1 x (10 ... 95) 2 x (16 ... 70)			1 x (25 ... 240) 2 x (25 ... 185)			1 x (25 ... 300) 2 x (25 ... 240)			1 x (25 ... 300) 2 x (25 ... 240)		
• Screw size		M8			M12			2 x M12			2 x M12		
• Torque	Nm	15			30			30			30		
Terminal connection													
• Conductor cross-section (Al/Cu), rm	mm ²	1 x (10 ... 50)			1 x (16 ... 35)			2 x (16 ... 35)			2 x (16 ... 35)		
• Conductor cross-section (Al/Cu), re	mm ²	1 x (10 ... 50)			1 x (16 ... 70)			2 x (16 ... 70)			2 x (16 ... 70)		
• Conductor cross-section (Al/Cu), sm	mm ²	1 x (35 ... 95)			1 x (35 ... 240)			2 x (35 ... 240)			2 x (35 ... 240)		
• Conductor cross-section (Al/Cu), se	mm ²	1 x (50 ... 95)			1 x (35 ... 300)			2 x (35 ... 300)			2 x (35 ... 300)		
• Required torque	Nm	15			25			25			25		
Auxiliary switches													
Rated insulation voltage U_i	V	690											
Rated peak withstand voltage U_{imp}	V	8000											
Rated operational current I_e													
• At AC 15, $U_e = 120$ V	A	8											
• At AC 15, $U_e = 230$ V	A	6											
• At AC 15, $U_e = 400$ V	A	4											
• At AC 15, $U_e = 690$ V	A	2											

¹⁾ According to IEC 60439, the rated uninterrupted current must be reduced when the devices are installed in control cabinets.

3KL, 3KM, 3NJ6 Switch Disconnectors with Fuses

3NJ6 In-Line Switch Disconnectors with Fuses up to 630 A

3NJ62 switch disconnectors with fuses
General data

Dimensional drawings

3-pole

3NJ62 switch disconnector, top view

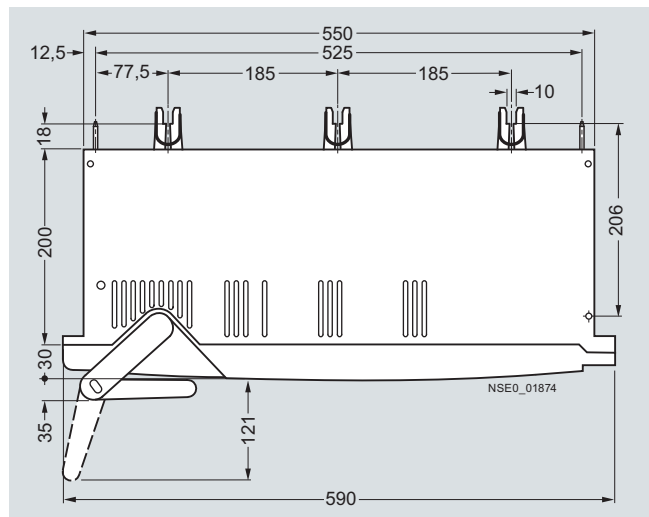

3NJ62 0, size 00

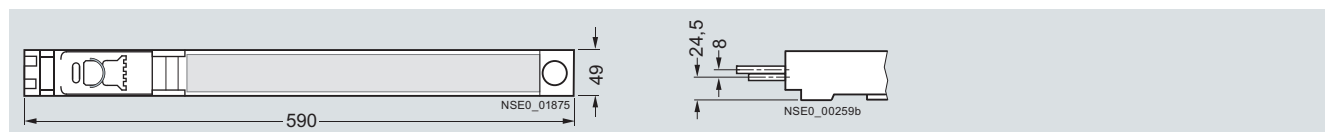

3NJ62 1, size 1

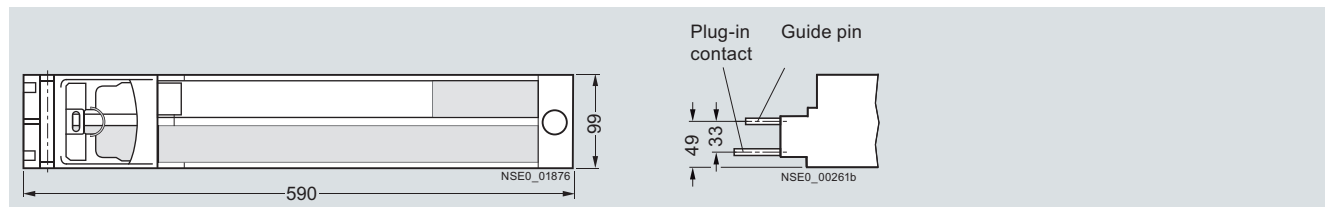

3NJ62 3 and 3NJ62 4, sizes 2 and 3

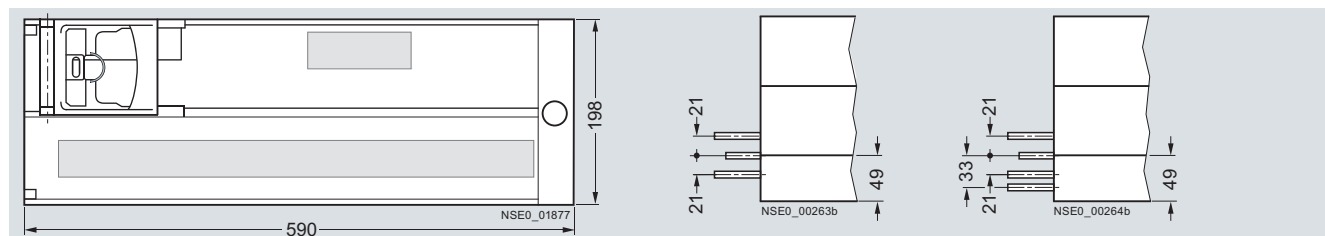

Clearance between phases

Alternating voltage versions, 3-pole

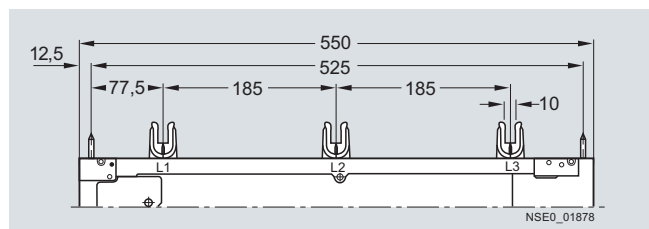

3NJ62 switch disconnector, top view

3KL, 3KM, 3NJ6 Switch Disconnectors with Fuses

3NJ6 In-Line Switch Disconnectors with Fuses up to 630 A

3NJ62 switch disconnectors with fuses General data

Ammeters

Moving-iron measuring instrument

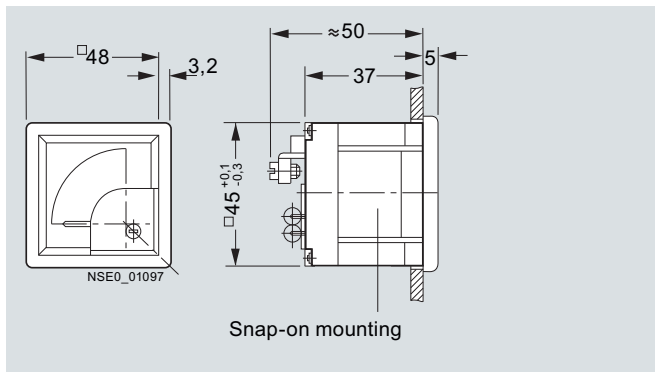

Left: view from the front
Right: view from the right

Bi-metal measuring instrument

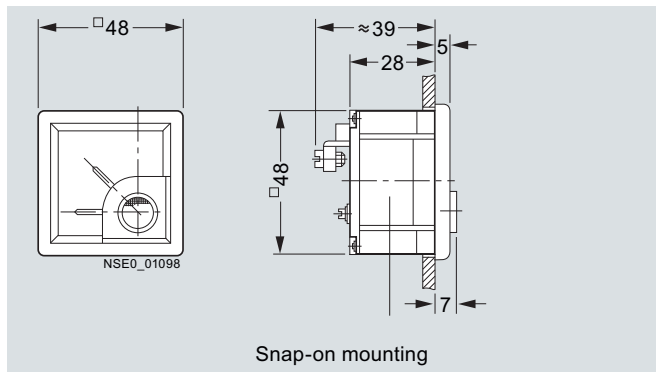

Left: view from the front
Right: view from the right

Current transformers

Current transformer for 3NJ62 switch disconnectors size NH 00 and NH 1 with feed-through opening $\varnothing 21$ mm

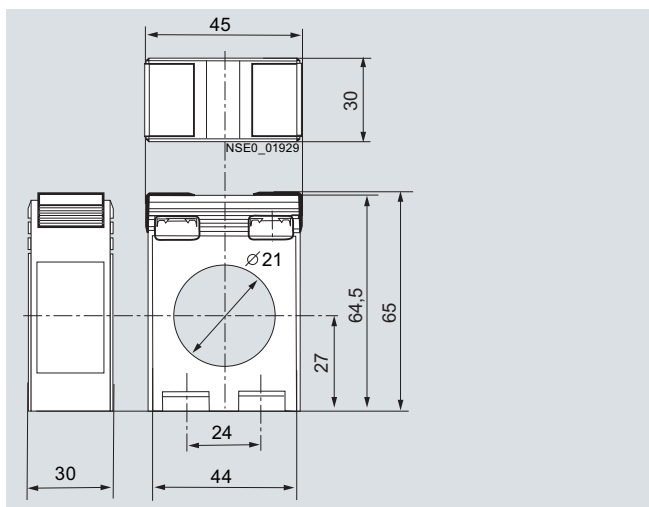

Top: view from the top
Bottom left: view from the front
Bottom right: view from the right

Current transformer for 3NJ62 switch disconnectors size NH 00 and NH 1 with feed-through opening $\varnothing 14$ mm

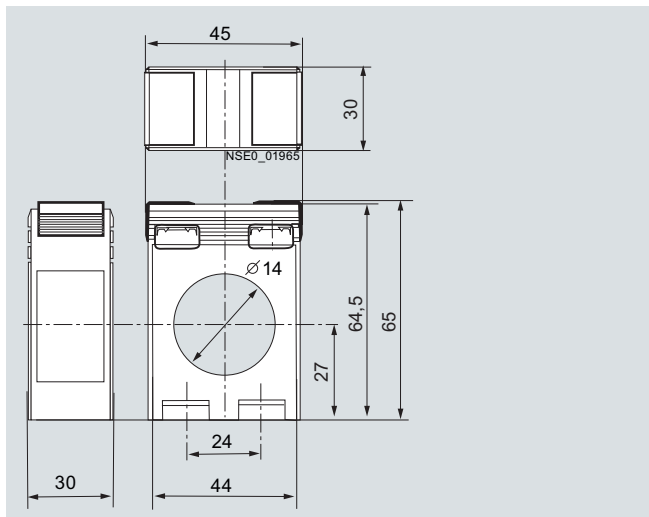

Current transformer for 3NJ62 switch disconnectors size NH 2 and NH 3:

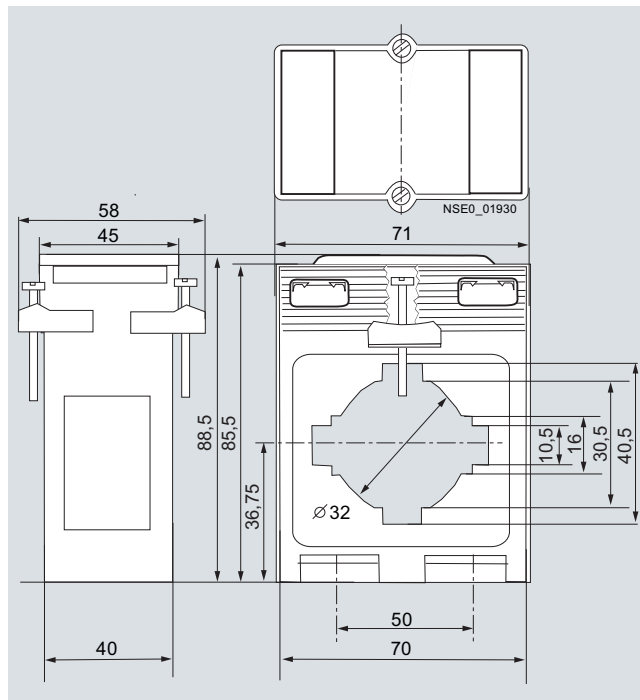

Top: view from the top
Bottom left: view from the front
Bottom right: view from the right

17

3KL, 3KM, 3NJ6 Switch Disconnectors with Fuses

3NJ6 In-Line Switch Disconnectors with Fuses up to 630 A

3NJ62 switch disconnectors with fuses
General data

Schematics

Circuit examples

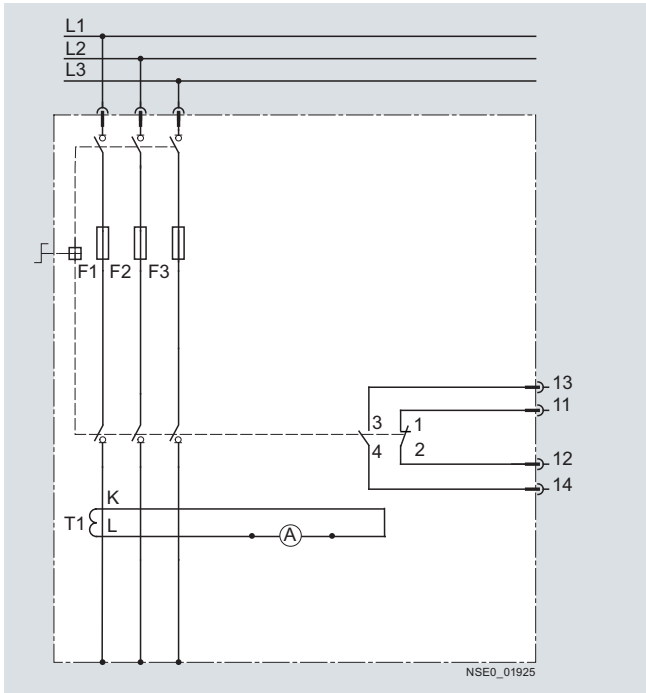

Circuit example with 1 current transformer and 1 ammeter wired, with 1 NO contact and 1 NC contact

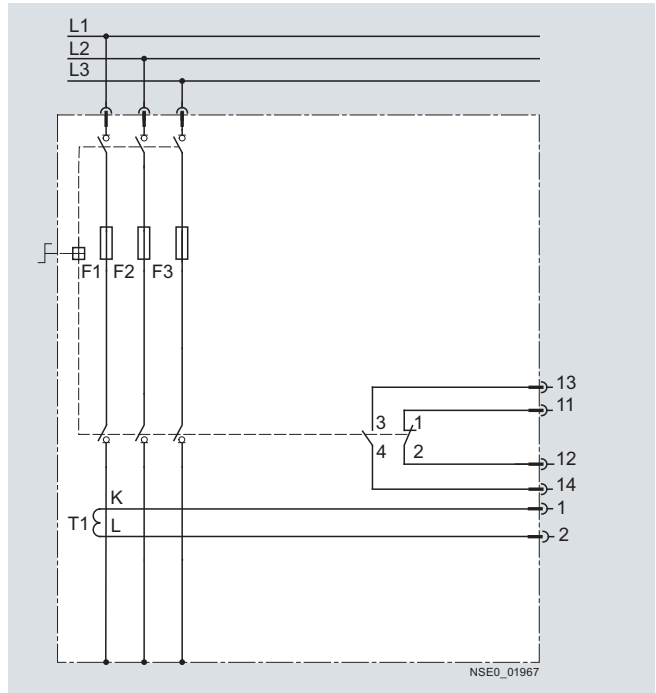

Circuit example with 1 current transformer and 1 multi-function plug wired, with 1 NO contact and 1 NC contact

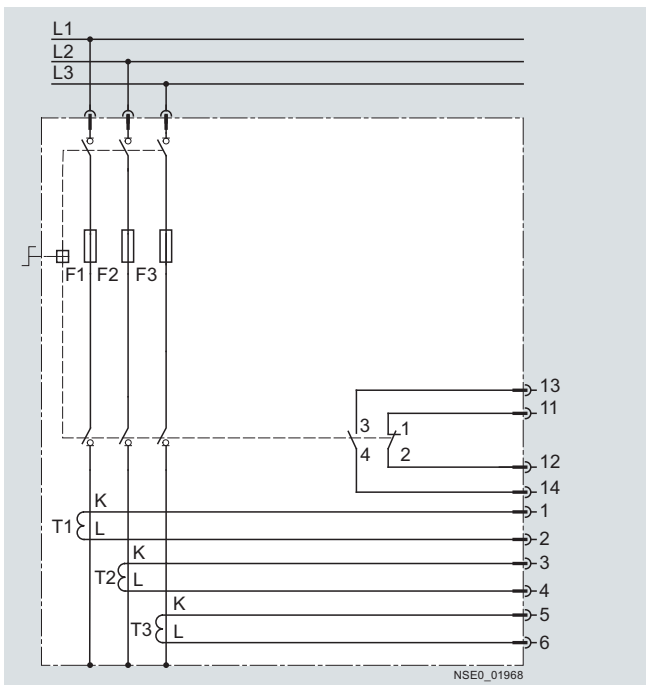

Circuit example with 3 current transformers wired to multi-function plug, multi-function plug wired, with 1 NO contact and 1 NC contact

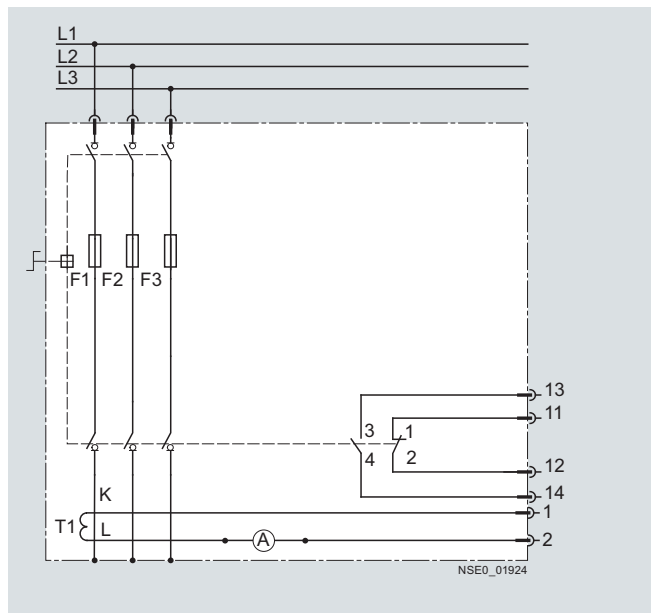

Circuit example with 1 current transformer wired to 1 ammeter and multi-function plug, with 1 NO contact and 1 NC contact

3KL, 3KM, 3NJ6 Switch Disconnectors with Fuses

3NJ6 In-Line Switch Disconnectors with Fuses up to 630 A

3NJ62 switch disconnectors with fuses

General data

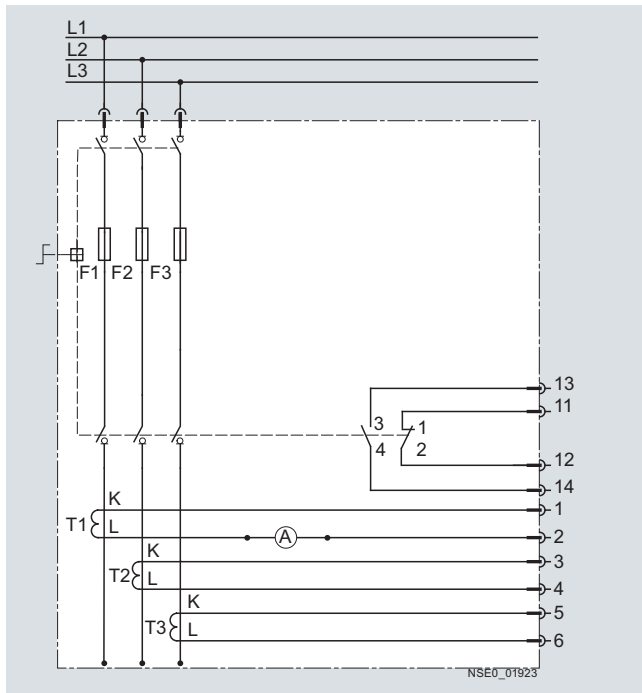

Circuit example with 3 current transformers wired to 1 ammeter and multi-function plug, with 1 NO contact and 1 NC contact

3KL, 3KM, 3NJ6 Switch Disconnectors with Fuses

3NJ6 In-Line Switch Disconnectors with Fuses up to 630 A

3NJ62 switch disconnectors with fuses
General data

Position of the terminals and current transformers

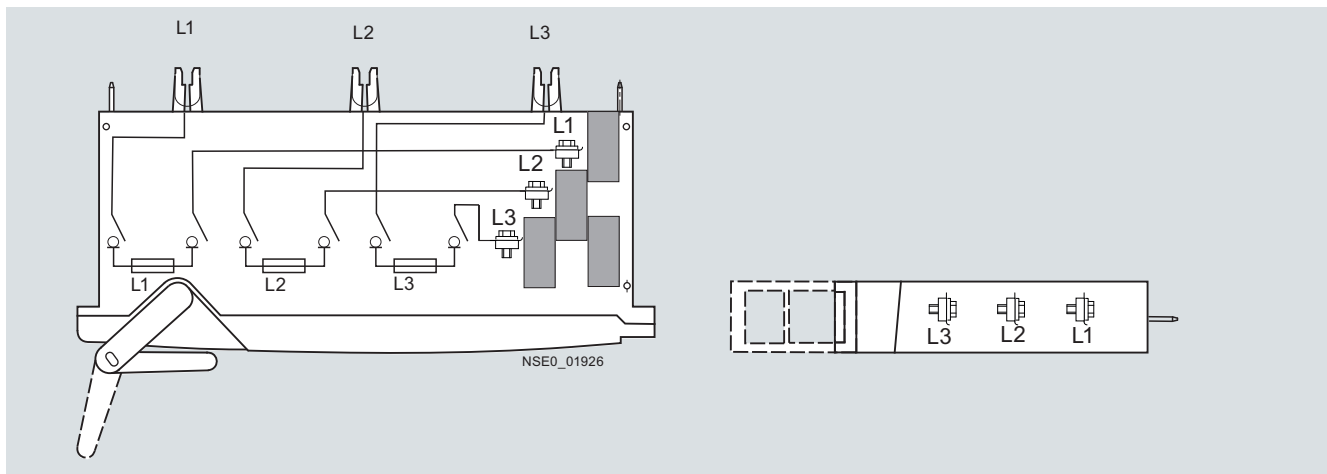

Position of the terminals for 3NJ62 switch disconnector size NH 00
Left: view from the top; Right: view from the right

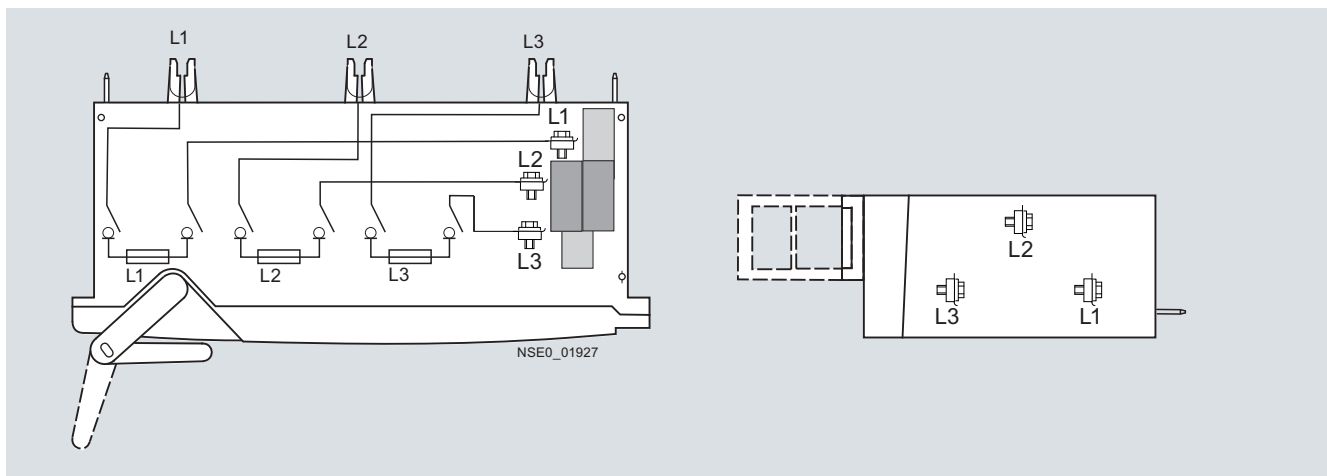

Position of the terminals for 3NJ62 switch disconnector size NH 1
Left: view from the top; Right: view from the right

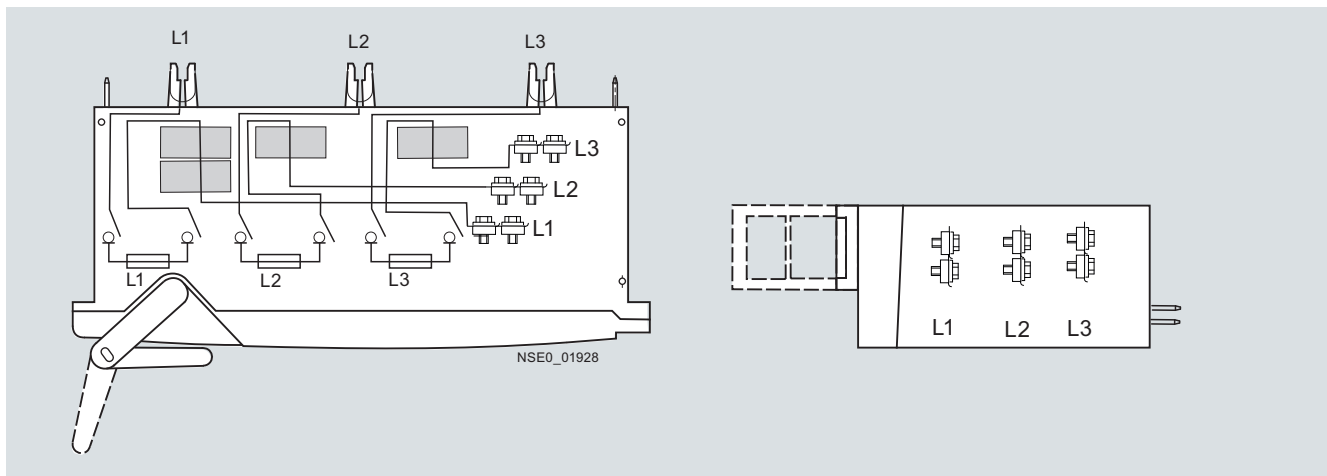

Position of the terminals for 3NJ62 switch disconnector size NH 2/NH 3
Left: view from the top; Right: view from the right

3NP, 3NJ4, 3NJ5 Fuse Switch Disconnectors

3NP Fuse Switch Disconnectors up to 630 A

General data

Design

The SENTRON 3NP4 and 3NP5 fuse switch disconnectors comprise a base and a removable fuse carrier with view and measuring window.

The base contains integral lyre-shaped contacts, arcing chambers and terminal fittings. The fuse links/isolating links are contained in the fuse carrier.

The fuse links can be replaced without tools.

The three conducting paths in the base and the fuse links in the fuse carrier are separated by partitions that overlap when opening and closing the device.

This type of intrinsic protection is called "complete compartmentalization" and effectively prevents inter-phase arcing.

SENTRON 3NP5 fuse switch disconnectors are also equipped with locating springs, which are fitted to the side of the base. These enable the "high speed closing" of devices, regardless of the actuating speed of the operator.

LV HRC fuses of sizes NH 000 to NH 3 according to IEC 60269-2 and DIN 43620 are used in the SENTRON 3NP4 and 3NP5 fuse switch disconnectors. SITOR semiconductor fuses can also be used.

For more detailed information, please refer to the operating instructions for the SENTRON 3NP4 and 3NP5 fuse switch disconnectors.

Auxiliary switches

The SENTRON 3NP4 and 3NP5 fuse switch disconnectors can also be retrofitted with auxiliary switches for indicating the switch position of the fuse carrier.

One switching block (1 CO) can be mounted on size NH 000 of the SENTRON 3NP4 fuse switch disconnector and two switching blocks (1 CO) can be mounted on sizes NH 00 to NH 3.

SENTRON 3NP5 fuse switch disconnectors can also be delivered with a 2-pole auxiliary switch (1 NO + 1 NC) if required. The version with fuse monitoring is fitted with this auxiliary switch as standard.

Function

Fuse monitoring by SIRIUS motor starter protector

For fuse monitoring, a SIRIUS motor starter protector is factory-fitted and hard-wired to the fuse carrier of the SENTRON 3NP4 and 3NP5 fuse switch disconnectors.

If the fuse carrier is closed, the three conducting paths of the SIRIUS motor starter protector are switched in parallel to the fuse links to be monitored. If the fuse carrier is open, all main current paths of the motor starter protector are off circuit.

The internal resistance of the motor starter protector is high enough not to impair the protective function of the monitored fuse links.

Failure of a fuse will trigger the motor starter protector. The auxiliary switch of the motor starter protector can be used for indication purposes or to disconnect the main circuit, e. g. through a contactor.

The signal cable for the SENTRON 3NP4 fuse switch disconnector size NH 00 needs to be ordered separately. For sizes NH 1 to NH 3 the connection is via flat connectors.

Delivery of the SENTRON 3NP5 fuse switch disconnectors includes the signal cable, complete with connector.

SIRIUS motor starter protectors cannot be used for fuse monitoring in branch circuits by motor starter protectors where a fault may result in > 220 V DC feedback.

In the case of parallel cables and meshed systems, only a voltage difference of > 24 V at the switch will trigger the motor starter protector.

Electronic fuse monitors

For electronic fuse monitoring, the EF monitor is factory-fitted and hard-wired to the fuse carrier of SENTRON 3NP5 fuse switch disconnectors.

The EF monitor works independently of any loads. Failure of a fuse can be relayed to a control room through integrated auxiliary switches (2 NO + 1 NC) by means of a centralized fault indication or used to isolate the load through e. g. a contactor

Actuation of the auxiliary switch depends on the EF monitor. Version "A" stands for "open-circuit principle", version "R" for closed-circuit principle" (see schematic circuit diagram on page 17/64).

If a fuse is tripped, a green LED signal flashes (general fault) and the location of the failed fuse is indicated by a red LED. Using more than one device facilitates identification of the affected branch circuit.

The EF monitor is automatically reset to the standby position once the faulty fuses are replaced. This state is indicated visually by the status display (green LED).

The EF monitor is also suitable for operation in industrial networks badly afflicted by harmonics.

3NP, 3NJ4, 3NJ5 Fuse Switch Disconnectors

3NP Fuse Switch Disconnectors up to 630 A

General data

Technical specifications

Standards		IEC/EN 60947-1, IEC/EN 60947-3				
Type		3NP40 1	3NP40 7	3NP42 7	3NP43 7	3NP44 7
Rated uninterrupted current I_u For fuse links acc. to DIN 43620	A Size	160 ¹⁾ 00C/000	160 00	250 1 and 0	400 2 and 1	630 3 and 2
Conventional free-air thermal current I_{th}	A	160 ¹⁾	160	250	400	630
Rated operational voltage U_e AC 50 Hz/60 Hz DC	V V	690 220 (3 conducting paths series-connected)	690	690 440 (2 conducting paths series-connected)	690 440 (2 conducting paths series-connected)	690 440 (2 conducting paths series-connected)
Rated insulation voltage U_i	V	690	690	800 ³⁾	800 ³⁾	800 ³⁾
Rated impulse withstand voltage U_{imp}	kV	6	6	6	6	6
Rated conditional short-circuit current with fuses (for fast switch-on)						
With fuse links						
Rated current	Size/A	000/100 (35)	00/160	1/250	2/400	3/630
At 400 V AC (690 V)	kA (rms value)	50 (50)	50	50	50	50
Maximum permissible let-through I^2t value	kA ² s	56 (7.8)	158	551	1515	4340
Permissible let-through current of the fuse	kA (peak value)	11 (5)	15	25	35	55
Short-circuit strength with fuses (with closed switch)						
With fuse links						
Rated current	Size/A	000/100	00/160	1/250	2/400	3/630
At 690 V	kA (rms value)	100	50	50	50	50
Permissible let-through current of the fuse	kA (peak value)	15	15	25	35	55
Rated making and breaking capacity (infeed from top or bottom)						
At 400 V AC, with fuse links or isolating links	Size	000	00	1	2	3
Rated breaking current I_c (p.f. = 0.35)	A (rms value)	800 (p.f. = 0.45)	800	2000	3200	5040
Rated operational current I_e for AC-21B, AC-22B, AC-23B	A A A	160 100	160 100	250 250	400 400	630 630
At 500 V AC, with fuse links or isolating links	Size	000	00	1	2	3
Rated breaking current I_c (p.f. = 0.35)	A (rms value)	320 (p.f. = 0.45)	320	750	1200	1890
Rated operational current I_e for AC-21B, AC-22B, AC-23B	A A A	160 100 40	160 100 40	250 250 --	400 400 --	630 630 --
At 690 V AC, with fuse links or isolating links	Size	000	00	1	2	3
Rated breaking current I_c (p.f. = 0.35)	A (rms value)	200/240 (p.f. = 0.45/0.95)	200/240 (p.f. = 0.45/0.95)	375	600	945
Rated operational current I_e for AC-21B, AC-22B, AC-23B	A A A	160 50 25	160 50 25	250 -- --	400 -- --	630 -- --
At 220 V/240 V DC, with fuse links ²⁾⁴⁾⁵⁾ or isolating links	Size	000	00	1	2	3
Rated operational current I_e at 220 V DC-23B/DC-21B 440 V DC-21B	A A	80/160 --	80/160 --	-- 250	-- 400	-- 630

1) 125/160 A only with 3NY1 236 feeder terminals and with 3NY1 822 (125 A) and 3NY1 824 (160 A) 21 mm wide fuse links; see [Accessories](#).

2) When switching without load (AC-20 B, DC-20 B), direct voltages up to 690 V DC can be applied.

3) For safety monitoring max. 690 V.

4) For degree of pollution 2, the switch disconnectors can be used up to 1000 V AC-20 B, DC-20 B (no-load switching).

5) Conducting paths in series: 3 for 3NP40; 2 for 3NP42, 3NP43 and 3NP44.

3NP, 3NJ4, 3NJ5 Fuse Switch Disconnectors

3NP Fuse Switch Disconnectors up to 630 A

General data

Standards Type	IEC/EN 60439-1, IEC/EN 60947-3					
	3NP40 1	3NP40 7	3NP42 7	3NP43 7	3NP44 7	
Capacitor switching capacity						
At 400 V AC						
Capacitor rating	kvar	50	50	--	--	--
Rated current I_n	A	72	72	--	--	--
At 525 V AC						
Capacitor rating	kvar	50	50	--	--	--
Rated current I_n	A	55	55	--	--	--
Permissible ambient temperature	°C	-25 ... +55 ¹⁾ for operation, -50 ... +80 when stored				
Mechanical endurance	Operat- ing cycles	2000	2000	1600	1000	1000
Degree of protection (operator side)						
Without molded-plastic masking frame/cable lug cover		IP00 (3NP40 with box terminal and properly connected conductors: IP20)				
With molded-plastic masking frame/cable lug cover		IP30 (switch closed), IP20 (switch open)				
Power loss of the switch disconnector at I_{th} (plus power loss of fuse links)						
Without busbar adapter	W	4.5 (at 100 A)	10	15	30	47
With busbar adapter	W	8.5 (at 100 A)	20	47	83	127
Main circuit connection						
Flat connector for cable lug according to DIN 46234, max. conductor cross-section (stranded)	mm ²	--	Up to 2 × 70 (M8)	Up to 150 (M10)	Up to 240 (M10)	Up to 2 × 240 (M12)
Box terminal/terminal (finely stranded with end sleeve)	mm ²	1.5 ... 50 (35)	2.5 ... 70 (50)	70 ... 150	120 ... 240	150 ... 300
Busbar (width × thickness)	mm	--	22 × 5	22 ... 30 × 5 ... 10	22 ... 30 × 5 ... 10	25 ... 40 × 5 ... 10
Louvered Cu strips, unperforated in terminals (width × thickness)	mm	8 × 8	Up to 9 × 8	Up to 16 × 8	Up to 20 × 10	Up to 24 × 10
Tightening torques for terminal screws						
For flat connector	Nm	--	10 ... 12	30 ... 35	30 ... 35	35 ... 40
With SIGUT box terminal/terminal	Nm	3 ... 3.5	8 ... 10	6	8	8
Auxiliary switch 1 CO (accessories)						
3NY3 035 AC 50 Hz/60 Hz up to 230 V Rated operational current I_e at AC-14	A	0.25 ($I_{th} = 5$ A), at 24 V DC: $I_e = 0.45$ A; flat terminations acc. to DIN 46244: A 2.8 × 0.5				
3NY3 030 AC 50 Hz/60 Hz up to 230 V Rated operational current I_e at AC-13 Permissible mounting positions	A	0.1 ($I_{th} = 0.1$ A); plug-in sleeve acc. to DIN 46245: A 2.8 ... 1 Vertical or horizontal installation (no reduction of specified switching capacity)				

1) Only with isolating links; otherwise, please observe specifications of fuse manufacturer.

3NP, 3NJ4, 3NJ5 Fuse Switch Disconnectors

3NP Fuse Switch Disconnectors up to 630 A

General data

Standards		IEC/EN 60947-1, IEC/EN 60947-3							
Type		3NP50		3NP52		3NP53		3NP54	
Rated uninterrupted current I_u For fuse links acc. to DIN 43620 (when SITOR semiconductor fuse links are used, a reduction of rated current is necessary – see Catalog "SITOR Configuration", Order No. E20001-A700-P302)	A Size	160 00		250 1 and 0		400 2 and 1		630 3 and 2	
Conventional free-air thermal current I_{th}	A	160		250		400		630	
Rated operational voltage U_e AC 50 Hz/60 Hz DC	V V	690 440 (3 conducting paths series-connected), 220 (2 conducting paths series-connected and with fuse monitoring through 3RV)							
Rated insulation voltage U_i	V	690 ¹⁾		690 ¹⁾		690 ¹⁾		690 ¹⁾	
Rated impulse withstand voltage U_{imp}	kV	6		6		6		6	
Rated conditional short-circuit current with fuses (for fast switch-on)									
With fuse links									
Rated current At 500 V AC	Size/A kA (rms value)	00/160 50		1/250 50		2/400 50		3/630 50	
Permissible let-through current of the fuses	kA (peak value)	15		25		40		50	
Short-circuit strength with fuses (with closed switch)									
With fuse links									
Rated current At 500 V AC	Size/A kA (rms value)	00/160 100		1/250 100		2/400 50		3/630 50	
Maximum permissible let-through I^2t value	kA ² s	223		780		2150		5400	
Permissible let-through current of the fuses	kA (peak value)	23		32		40		60	
Rated short-circuit making capacity with isolating links²⁾ At 500 V AC									
	Size kA (peak value)	00 6		1 17		2 17		3 17	
Rated making and breaking capacity²⁾ (infeed from top or bottom) ³⁾									
Size		00		1	0	2	1	3	2
At 400 V AC, with fuse links Breaking current I_c (p.f. = 0.35)	A (rms value)	1600		2500	1600	4000	2500	5040	4000
Rated operational current I_e at AC-21B, AC-22B, AC-23B	A	160		250	160	400	250	630	400
At 500 V AC, with fuse links Breaking current I_c (p.f. = 0.35)	A (rms value)	1300		2500	1600	4000	2500	5040	4000
Rated operational current I_e at AC-21B, AC-22B, AC-23B	A	160		250	160	400	250	630	400
At 690 V AC, with fuse links Breaking current I_c (p.f. = 0.35)	A (rms value)	800		1280	1000	2520	1600	3200	2520
Rated operational current I_e for AC-21B, AC-22B, AC-23B	A A	160 100		250 160	160 125	400 315	250 200	630 400	400 315
At 220 (440) V DC, with 2 (3) conducting paths series-connected and fuse links Breaking current I_c ($L/R = 15$ ms)	A	640		1000	640	1600	1600	2520	1600
Rated operational current I_e at DC-23B	A	160		250	160	250	250	630	400

1) When observing degree of pollution 2 (instead of 3) operation is also possible up to $U_i = 1000$ V.

2) Rated making and breaking current according to IEC 60947-3
 Rated making current
 $I = 10 \times I_e$ (AC-23); $3 \times I_e$ (AC-22); $1.5 \times I_e$ (AC-21)
 Rated breaking current
 $I_e = 8 \times I_e$ (AC-23); $3 \times I_e$ (AC-22); $1.5 \times I_e$ (AC-21).

3) When using electronic fuse monitoring, infeed must be from the top.

3NP, 3NJ4, 3NJ5 Fuse Switch Disconnectors

3NP Fuse Switch Disconnectors up to 630 A

General data

Standards	Type	IEC/EN 60947-1, IEC/EN 60947-3			
		3NP50	3NP52	3NP53	3NP54
Switching capacity with isolating links¹⁾ (infeed from top or bottom ¹⁾)					
At 400 V AC, with isolating links Breaking current I_c (p.f. = 0.35)	Size A (rms value)	00 <u>1600</u>	1 <u>2500</u>	2 <u>2500</u>	3 <u>4000</u>
Rated operational current I_θ for AC-21B, AC-22B, AC-23B	A A	160 160	250 250	400 315	630 500
At 500 V AC, with isolating links Breaking current I_c (p.f. = 0.35)	A (rms value)	1300	2500	2500	4000
Rated operational current I_θ for AC-21B, AC-22B, AC-23B	A A	160 160	250 250	400 315	630 500
At 690 V AC, with isolating links Breaking current I_c (p.f. = 0.35)	A (rms value)	800	1280	1600	2520
Rated operational current I_θ for AC-21B, AC-22B, AC-23B	A A	160 100	250 160	400 200	630 315
At 220 V DC, with isolating links Breaking current I_c ($L/R = 15$ ms) Rated operational current I_θ at DC-23B	A A	640 160	1000 200	1600 400	1600 400
Switching capacity for horizontal installation Up to 690 V AC-22B		No reduction in specified switching capacity (values for AC-23B up to 690 V on request)			

Permissible mounting positions

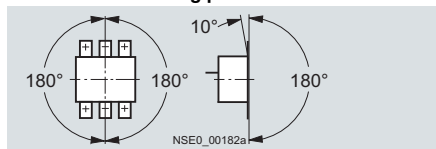

3NP5

1) Insert silver-plated isolating links.

3NP, 3NJ4, 3NJ5 Fuse Switch Disconnectors

3NP Fuse Switch Disconnectors up to 630 A

General data

Standards		IEC/EN 60947-1, IEC/EN 60947-3				
Type		3NP50	3NP52	3NP53	3NP54	
Capacitor switching capacity						
At 400 V AC						
Capacitor rating	kvar	80	90	150	250	
Rated current I_n	A	116	130	216	361	
At 525 V AC						
Capacitor rating	kvar	100	125	200	300	
Rated current I_n	A	110	137	220	330	
Permissible ambient temperature		°C -25 ... +55 for operation ¹⁾ , -50 ... +80 when stored				
Mechanical endurance		Operating cycles 1600				
Degree of protection						
Without molded-plastic masking frame		IP00 ²⁾				
With molded-plastic masking frame and closed fuse carrier on the operator side		IP30				
With open fuse carrier		IP10				
Power loss of the switch disconnecter at I_{th} (plus power loss of the fuse links)						
Without busbar adapter		W	7.8 (16.3) ³⁾	7.5	15	39
Main conductor connections						
Cable lug, max. conductor cross-section (stranded)	mm ²	2.5 ... 120	6 ... 150	6 ... 240	6 ... 2 × 240	
Busbar	mm	16 ... 22	22 ... 30	22 ... 30	22 ... 30	
Clamp terminal	mm ²	2.5 ... 50	35 ... 120	--	--	
Tightening torque						
With cable lug	Nm	18 ... 22	25 ... 30	25 ... 30	25 ... 30	
With busbar	Nm	18 ... 22	25 ... 30	25 ... 30	25 ... 30	
With clamp terminal	Nm	9 ... 11	5 ... 6	--	--	
Terminal screws						
With cable lug		M8	M10	M10	M10	
With busbar		M8	M10	M10	M10	
With clamp terminal		M8	2 × M6	--	--	
Protective conductor connections						
Cable lug acc. to DIN 46234	mm ²	--	2.5 ... 70	6 ... 2 × 70	6 ... 2 × 120	
Busbar	mm	--	25	25	30	
Terminal screws		--	M8	M10	M10	
Auxiliary switch 1 NO + 1 NC (accessories) (the same voltage potential must be applied to both NO and NC contact)						
At AC 50 Hz/60 Hz up to 400 V, rated operational current I_e at AC-12/AC-15 A	A	16/6				
Flat connector (DIN 46244)		A 6.3 ... 0.8				
Permissible mounting positions		Vertical or horizontal (partially reduced switching capacity with horizontal mounting)				
Fuse monitoring with 3RV motor starter protectors		See Motor Starter Protectors				
Electronic fuse monitoring						
Rated voltage AC 50 Hz/60 Hz	V	400 - 15 % ... 500 V + 10 %, self-powered (infeed from top)				
Max. inrush current	A	20				
Uninterrupted current	A	5				
Breaking current	A	5				
Switching capacity	VA	1000				
Short-circuit strength (1 ms)	A	100				
Response time	s	< 1				
Temperature range (operation)	°C	-10 ... +75				
Plug-in connectors/connections		6-pole				
Minimum required potential difference between upper and lower switch connections (e. g. for use in meshed systems)	V	>10				
Signaling contact for electronic fuse monitoring		2 NO + 1 NC				
Rated operational current I_e						
At 250 V, DC-13	A	0.27				
At 240 V, AC-15	A	1.5				
Thermal free-air rated current I_{th}	A	5				

1) When using isolating links. If using fuse links, please observe specifications of fuse manufacturer.

2) For 3NP52 with terminal clamp connection, degree of protection IP10.

3) With busbar adapter.

3NP, 3NJ4, 3NJ5 Fuse Switch Disconnectors

3NP Fuse Switch Disconnectors up to 630 A

3NP4 for power distribution

Dimensional drawings

3NP40 10

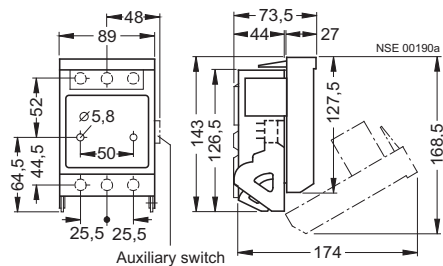

Cutout for 3NP35 and 3NP40 10

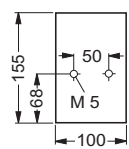

3NP40 10

with 3NY1 995 quick retaining plate mounting rail center-to-center spacing: 125 mm

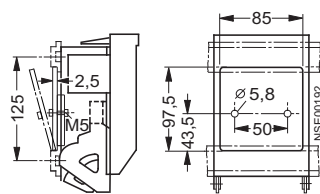

3NY1 995 quick retaining plate for 3NP40 10 and 3NP40 70

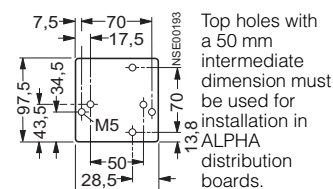

Top holes with a 50 mm intermediate dimension must be used for installation in ALPHA distribution boards.

3NP40 10

with 3NY1 237 3-phase busbar for 2 fuse switch disconnectors

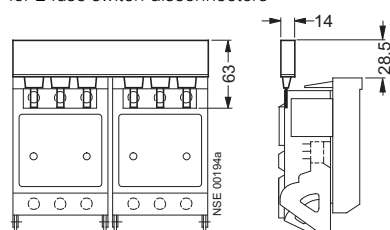

3NY1 265

covering cap for 3NY1 238 3-phase busbar

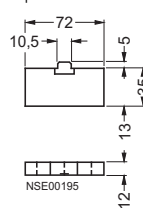

3NP40 10

with 3NY1 235 triple terminal

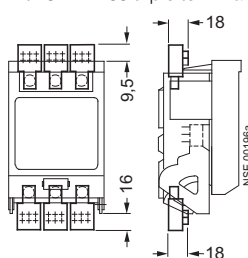

3NP40 10

with 3NY1 236 feeder terminal

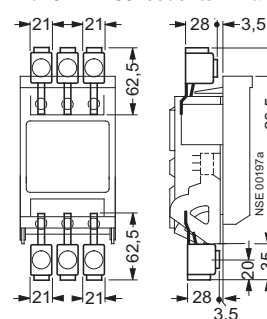

3NP40 10

with 3NY1 251 molded-plastic masking frame

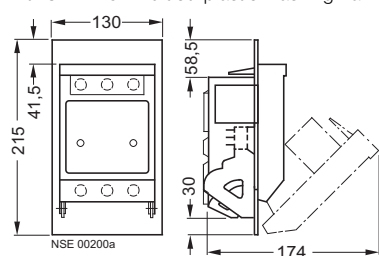

3NP40 15-1CJ01

with busbar adapter, flat, busbars of width 12 mm or 15 mm and thickness 5 mm or 10 mm, bottom connection

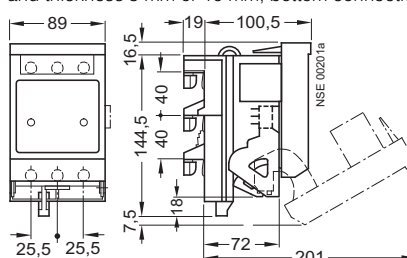

3NP40 15-1CK01

with busbar adapter, flat, busbars of width 12 mm or 15 mm and thickness 5 mm or 10 mm, bottom connection

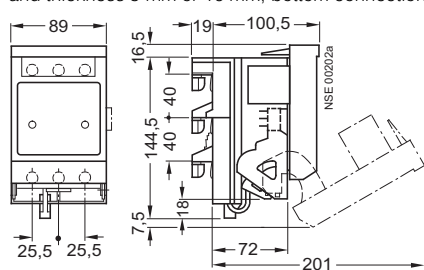

3NP40 15-0CJ01

with busbar adapter, deep, busbars of width 12 mm or 15 mm and thickness 5 mm or 10 mm, bottom connection

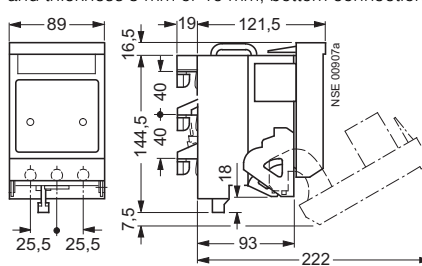

3NP40 16-1CJ01

with busbar adapter, busbars of width 12, 15, 20 mm or 30 mm and thickness 5 mm or 10 mm, flat, T, I profiles and other renowned busbar systems, bottom connection

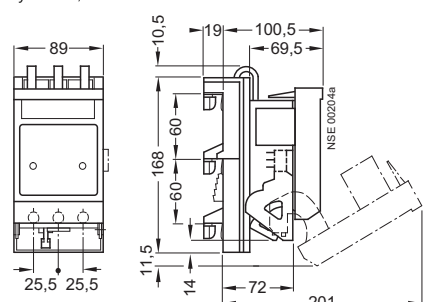

3NP40 16-1CK01

with busbar adapter, busbars of width 12, 15, 20, 25 mm or 30 mm and thickness 5 mm or 10 mm, flat, T, I profiles and other renowned busbar systems, top connection

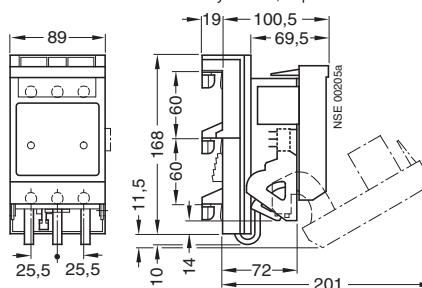

3NP, 3NJ4, 3NJ5 Fuse Switch Disconnectors

3NP Fuse Switch Disconnectors up to 630 A

3NP4 for power distribution

3NP40 70 for surface mounting

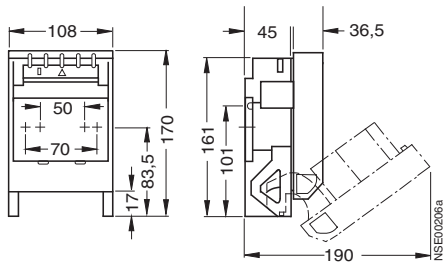

Drilling pattern for 3NP40 70

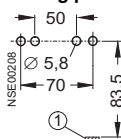

3NP40 75-0 with busbar adapter, deep, busbars of width 12 mm or 15 mm and thickness 5 mm or 10 mm

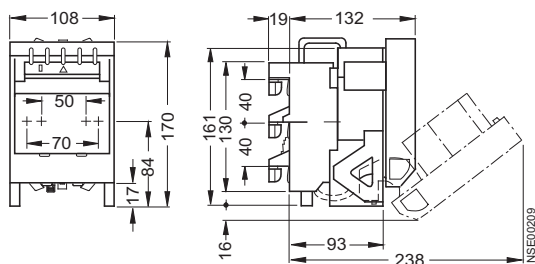

3NP40 75-1 with busbar adapter, flat, busbars of width 12 mm or 15 mm and thickness 5 mm or 10 mm

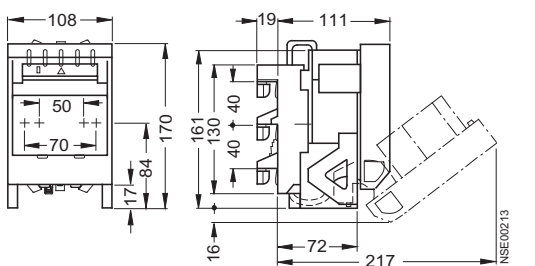

For metal frames Cutouts for 3NP4

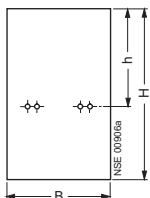

Type	Cover betw. assembly kit	Panel cut-out min.				
		Type	B	H	B	H
Molded-plastic masking frame <u>behind</u> panel						
3NP40 1	3NY1 251	130	215	100	180	100
3NP40 7	3NY7 200, 3NY7 201	130	215	118	195	110
3NP42 7	3NY7 220	220	375	210	275	157
3NP43 7	3NY7 230	245	375	235	315	174
3NP44 7	3NY7 240	290	375	280	325	178
Molded-plastic masking frame <u>in front of</u> panel						
Type B H B H h ¹⁾						
3NP40 1	3NY1 251	130	215	100	155	87
3NP40 7	3NY7 200, 3NY7 201	130	215	118	195	110
3NP42 7	3NY7 220	220	375	198	275	157
3NP43 7	3NY7 230	245	375	224	315	174
3NP44 7	3NY7 240	290	375	270	325	178

1) h = distance from upper edge of panel cut-out to center of disconnector mounting.

3NP42 70, 3NP43 70, 3NP44 70 for surface mounting

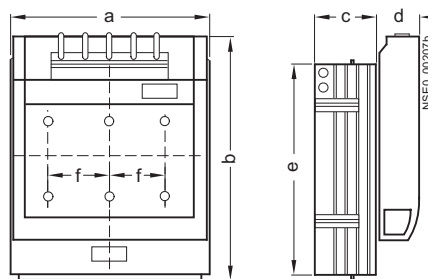

Type	a	b	c	d	e	f
3NP42 70	184	243	66	45.5	215	57
3NP43 70	210	288	80	48	255	65
3NP44 70	256	300	94.5	48	267	81

3NY73 22 quick retaining plate

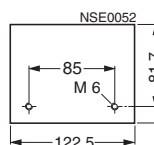

Drilling pattern for 3NP43

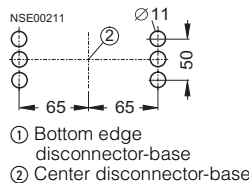

For plastic frames

Cutouts²⁾
for 3NP40 70

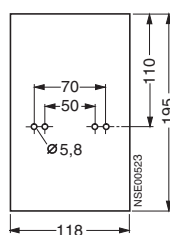

Cut-outs²⁾
for 3NP43

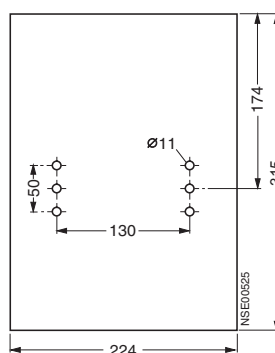

Drilling pattern for 3NP42 70

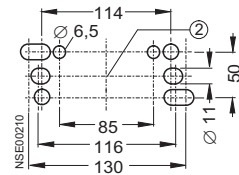

Drilling pattern for 3NP44

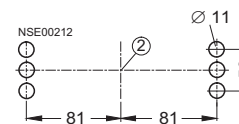

Cut-outs²⁾
for 3NP42

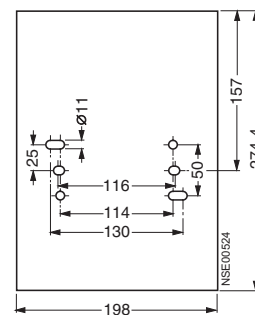

Cut-outs²⁾
for 3NP44

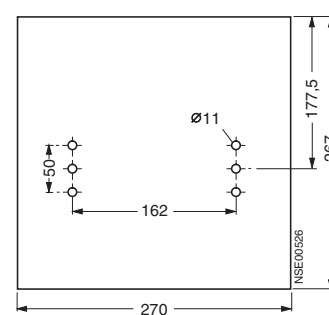

2) Cover is placed open on the switchgear cabinet panel, for cover behind control cabinet panel: cut-out dimensions on request.

3NP, 3NJ4, 3NJ5 Fuse Switch Disconnectors

3NP Fuse Switch Disconnectors up to 630 A

3NP4 for power distribution

3NP40 70-0F

for surface mounting and flush mounting

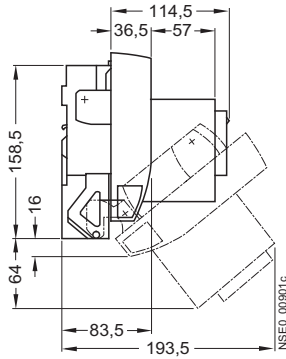

3NP40 75-0F

with busbar adapter, deep, 40 mm, busbars of width 12 mm or 15 mm and thickness 5 mm or 10 mm

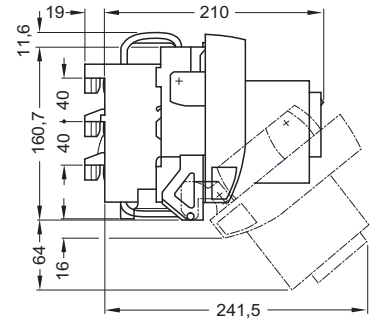

3NP40 75-1F

with busbar adapter, flat, 40 mm, busbars of width 12 mm or 15 mm and thickness 5 mm or 10 mm

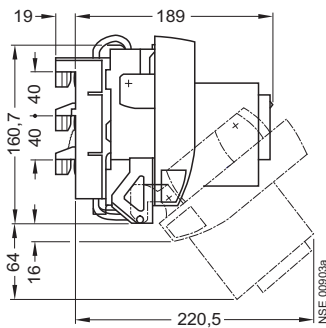

3NP40 76-0F

with busbar adapter, flat, 60 mm, busbars of width 12 mm or 30 mm and thickness 5 mm or 10 mm

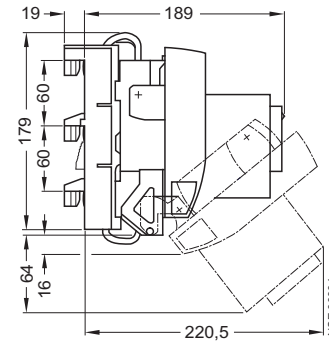

3NP40 76-1

with busbar adapter, busbars with a width of 12 mm to 30 mm and a thickness of 5 mm or 10 mm, flat, T and I profiles

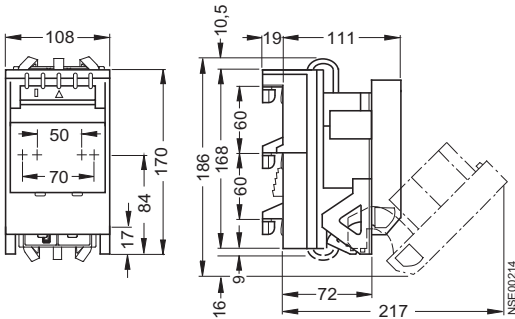

3NP42 75-1

3NP42 76-1

3NP43 76-1

3NP44 76-1

with busbar adapter, busbars with a width of 12 mm to 30 mm and a thickness of 5 mm or 10 mm, flat, T and I profiles

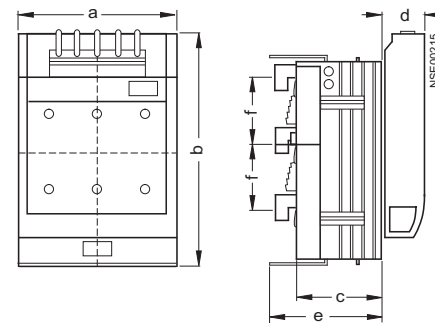

Type	a	b ¹⁾	c	d	e	f
3NP42 75-1	184	243	83 ²⁾	45.5	111	40
3NP42 76-1	184	243	83 ²⁾	45.5	111	60
3NP43 76-1	210	288	97	48	125	60
3NP44 76-1	256	300	112	48	139	60

1) For BGV A3 plus dimension c of the cable lug covers (see next page).

2) The 3NY7 820 molded-plastic masking frame is used for depth compensation (below) when installed together with size 000 or size 00 in ALPHA distribution boards.

3NP, 3NJ4, 3NJ5 Fuse Switch Disconnectors

3NP Fuse Switch Disconnectors up to 630 A

3NP4 for power distribution

3NY7 200 molded-plastic masking frame
for 3NP40 7
for installation in any distribution board

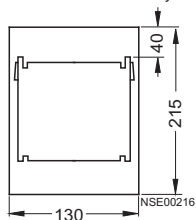

3NY7 201 molded-plastic masking frame
for 3NP40 7.-
for 3NP40 7.-CA01

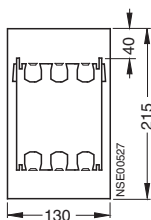

3NY7 220 molded-plastic masking frame
for 3NP42
for installation in any distribution board

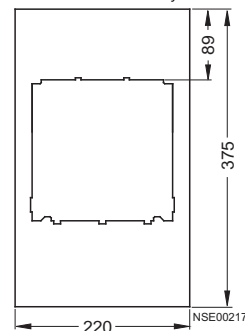

3NY7 230 molded-plastic masking frame
for 3NP43
for installation in any distribution board

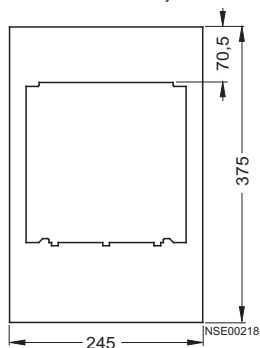

3NY7 240 molded-plastic masking frame
for 3NP44
for installation in any distribution board

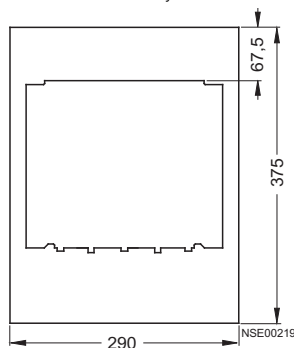

3NY7 820 molded-plastic masking frame
for one 3NP42 70 switch disconnector
for installation in ALPHA distribution boards

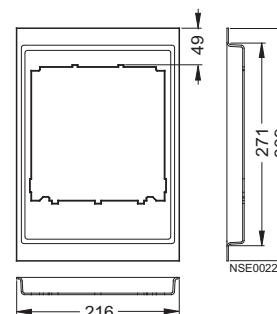

3NY7 500 molded-plastic masking frame
for one 3NP40 switch disconnector, left
for installation in ALPHA distribution boards

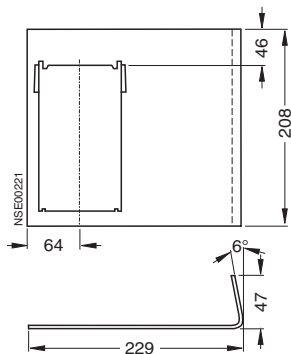

3NY7 501 molded-plastic masking frame
for one 3NP40 switch disconnector, right
for installation in ALPHA distribution boards

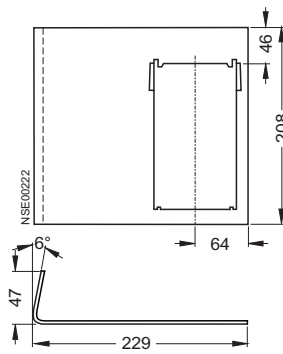

3NY7 502 molded-plastic masking frame
for two 3NP40 switch disconnectors
for installation in ALPHA distribution boards

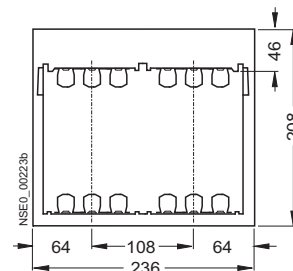

3NY7 600 touch protection cover
for installation in ALPHA distribution boards
for 3NP40 76 switch disconnectors

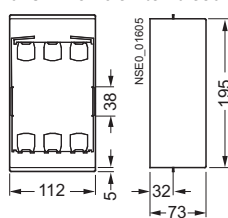

3NY7 601 touch protection cover
for 3NP40 75 and 3NP40 76 switch disconnectors

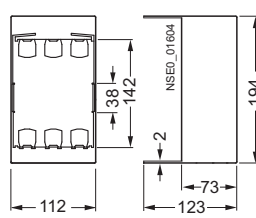

**Cable lug cover for 3NP40 7
with flat connector, 3NY7 101**

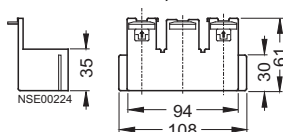

**Cable lug cover for 3NP42 to 3NP44,
3NY7 121, 3NY7 131, 3NY7 141**

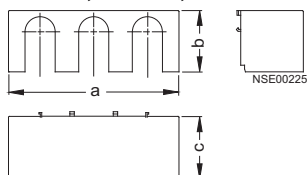

Type	a	b	c
3NY7 121	181	65	67
3NY7 131	207	79	50
3NY7 141	253	94	47

3NP, 3NJ4, 3NJ5 Fuse Switch Disconnectors

3NP Fuse Switch Disconnectors up to 630 A

3NP5 for extended technical requirements

Dimensional drawings

3NP50 60, 160 A
for surface mounting

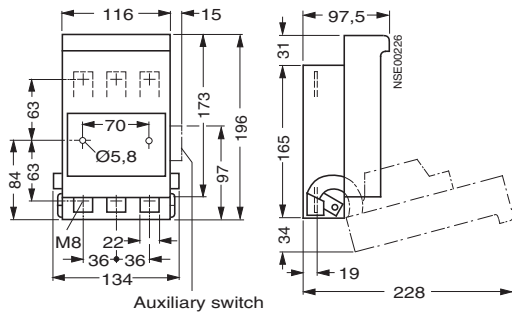

3NP50 60, 160 A
with fuse monitoring by 3RV1 motor starter protector,
with plug-in connector

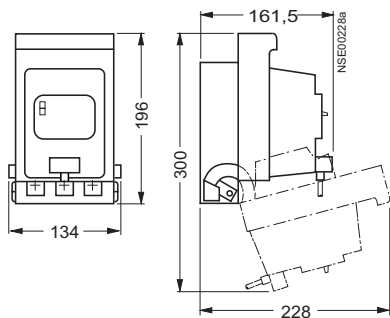

3NP50 60, 160 A
with molded-plastic masking frame
for any type of installation

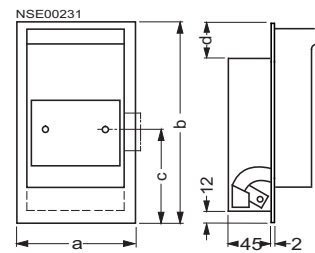

Type	a	b	c	d
3NY1 105	135	215	95.5	38
3NY1 115	135	215	95.5	38
3NY1 106	135	290	144.5	64
3NY1 108	135	290	144.5	64
3NY1 208	149	250	115	53.5

**3NY1 107 molded-plastic
masking frame**

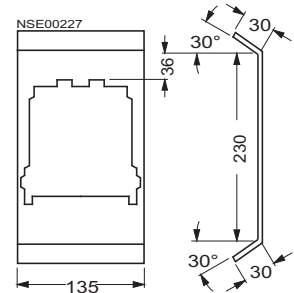

For plastic frames
Cut-out for 3NP50 60,
with and without auxiliary switch

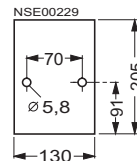

Cut-out
for 3NY1 208 mounting kit

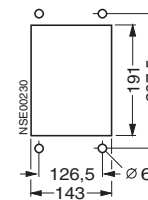

For metal frames
Cutouts for 3NP5

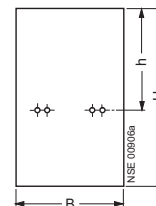

Type	Cover betw. assembly kit		Panel cut-out min.			
Type	B	H	B	H	h ¹⁾	
Molded-plastic masking frame <u>behind</u> panel						
3NP50 6	3NY1 105 ²⁾	135	215	130	206	115
3NP50 6	3NY1 125					
3NP52 6	3NY1 210	222	300	210	293	146
3NP53 6	3NY1 211	245	300	235	293	146
3NP54 6	3NY1 212	290	300	280	293	146
Molded-plastic masking frame <u>in front</u> of panel						
Type	B	H	B	H	h ¹⁾	
3NP50 6	3NY1 105	135	215	130	205	115
3NP50 6	3NY1 208	149	250	143	191	--
3NP52 6	3NY1 210	220	300	210	262	132
3NP53 6	3NY1 211	245	300	234	262	132
3NP54 6	3NY1 212	290	300	279	262	132

- h = distance from upper edge of panel cut-out to center of disconnector mounting.
- With standard molded-plastic masking frame behind panel and corresponding panel cutout, the standard switching capacity is reduced to the following AC 23B values: at 400 V I_e 160 A, at 500 V from I_e 160 A to 125 A and at 690 V from I_e 100 A to 50 A.

3NP, 3NJ4, 3NJ5 Fuse Switch Disconnectors

3NP Fuse Switch Disconnectors up to 630 A

3NP5 for extended technical requirements

3NP5. 60, 250 to 630 A
for surface mounting

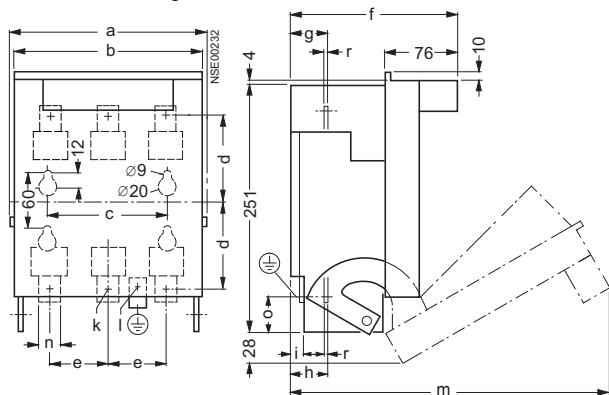

3NP5. 60, 250 to 630 A with fuse monitoring
by 3RV motor starter protector, with plug-in connection

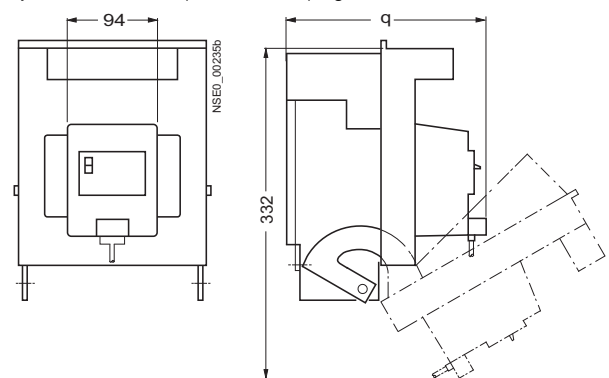

3NP50 65, 160 A with busbar adapter,
busbars of width 12 mm and thickness 5 mm or 10 mm

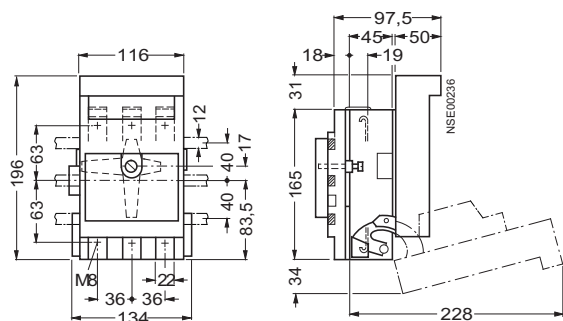

3NP5. 60, 160 to 630 A
with electronic fuse monitoring,
with plug-in connection and control
cable

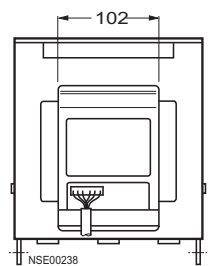

3NP50 60, 160 A
with electronic fuse monitoring,
with plug-in connection and control
cable

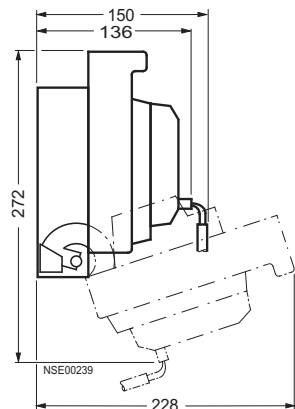

3NP5. 60, 250 to 630 A
with molded-plastic masking frame, for installation

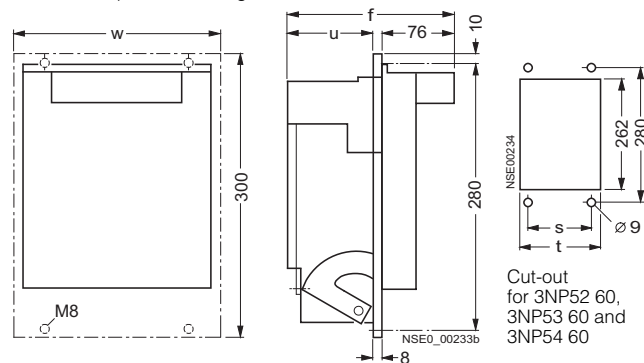

Type	a	b	c	d	e	f	g	h	i
3NP52 60	207	202	130	93	62	176	38	41	11.5
3NP53 60	231	226	130	106	70	192	39	39	11.5
3NP54 60	276	271	200	111	85	207	40.5	40.5	11.5
	k ¹⁾	l ¹⁾	m	n	o	q	r	s	t
3NP52 60	M10	M8	336	25	32	212	3.6	156	210
3NP53 60	M10	M10	352	25	25	228	4.4	180	234
3NP54 60	M10	M10	367	30	25	243	6	225	279
	u	w	x	y					
3NP52 60	89.5	220	186.5	200.5					
3NP53 60	105.5	245	202.5	216.5					
3NP54 60	120.5	290	217.5	231.5					

1) Through hole for screw.

3NP50 65, 160 A with busbar adapter,
with fuse monitoring by 3RV motor starter protector,
with plug-in connector

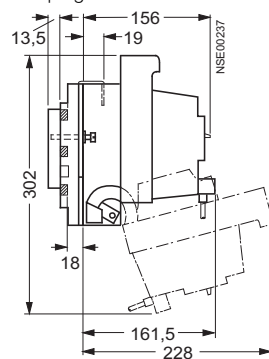

3NP5. 60, 250 to 630 A
with electronic fuse monitoring,
with plug-in connection and control
cable

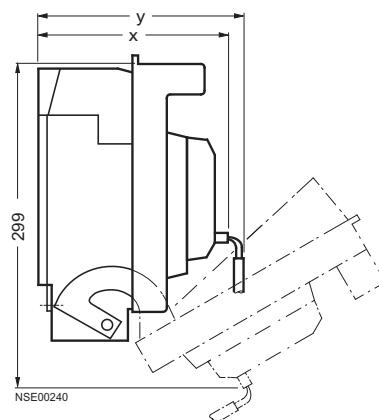

3NP, 3NJ4, 3NJ5 Fuse Switch Disconnectors

3NP Fuse Switch Disconnectors up to 630 A

3NP5 for extended technical requirements

Schematics

Function for auxiliary contacts – main contact elements with SENTRON 3NP4 and 3NP5

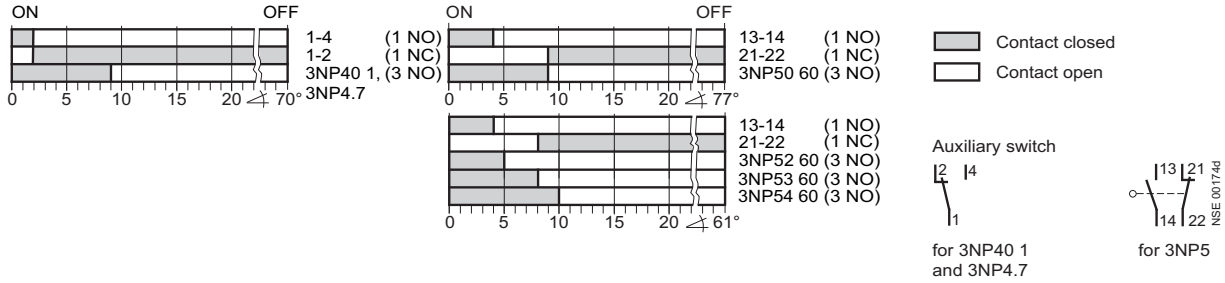

SENTRON 3NP fuse switch disconnector with fuse monitoring (with 3RV1 motor starter protector, with auxiliary switch 1 NO + 1 NC)

Circuit diagram of main circuit

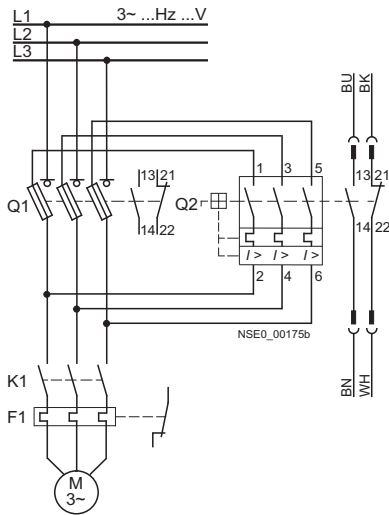

Circuit diagram of auxiliary circuit

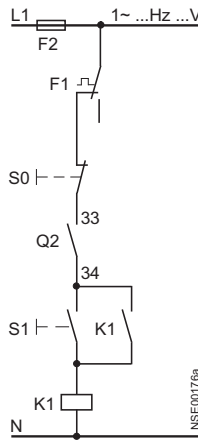

- Q1 = Fuse switch disconnector
- Q2 = Motor starter protector
- K1 = Contactor
- S1 = ON button
- S0 = OFF pushbutton
- F1 = Overload relay
- F2 = Control-circuit fuse

SENTRON 3NP5 fuse switch disconnector with electronic fuse monitoring

Schematic circuit diagram

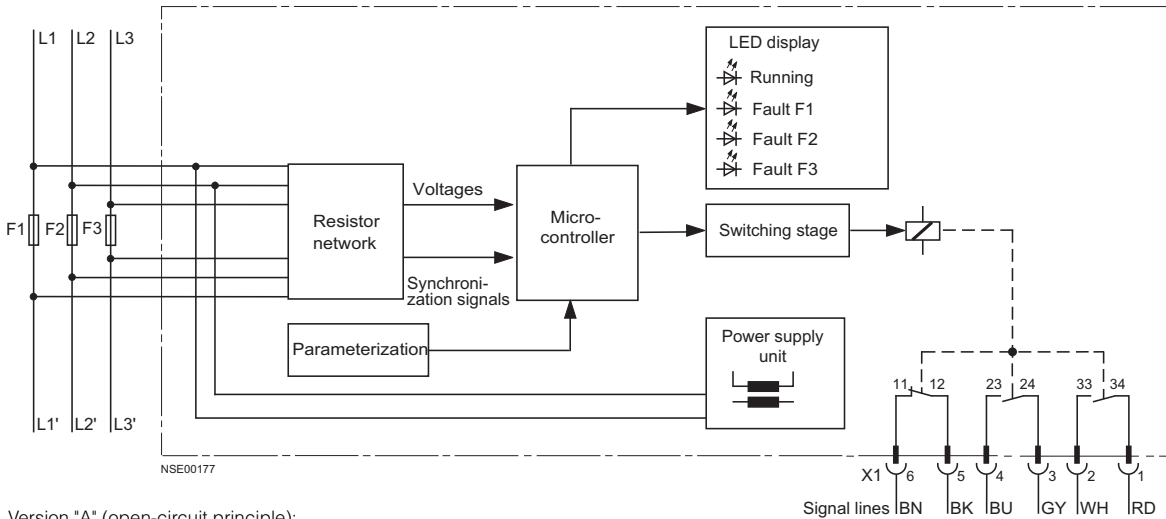

Version "A" (open-circuit principle):
 Auxiliary switches only pick up if fuse faulty and voltage is applied.
 Version "R" (closed-circuit principle):
 Auxiliary contacts pick up as soon as voltage is applied and as long as fuses are intact.

17

3NP, 3NJ4, 3NJ5 Fuse Switch Disconnectors

3NJ4, 3NJ5 In-Line Fuse Switch Disconnectors up to 1250 A

General data

Overview



3NJ4 fuse switch disconnector

All key product features at a glance

- Compliant with IEC/EN 60439-1, IEC/EN 60947-3
- Voltage levels up to 690 V AC
- Rated operational current from 160 A to 1250 A
- Fuse links according to DIN 43620 Part 1 can be used – nickel-plated fuse blades are not permissible due to the high transfer resistance
- In open position safe from touch by the back of the hand (exception 3NJ56: IP00)
- Parking position for maintenance
- 1-pole or 3-pole switchable
- Vertical and horizontal mounting position
- Climate-proof
- Degree of protection IP30 with closed fuse carriers, IP10 with open fuse carriers (exception 3NJ56: IP00)

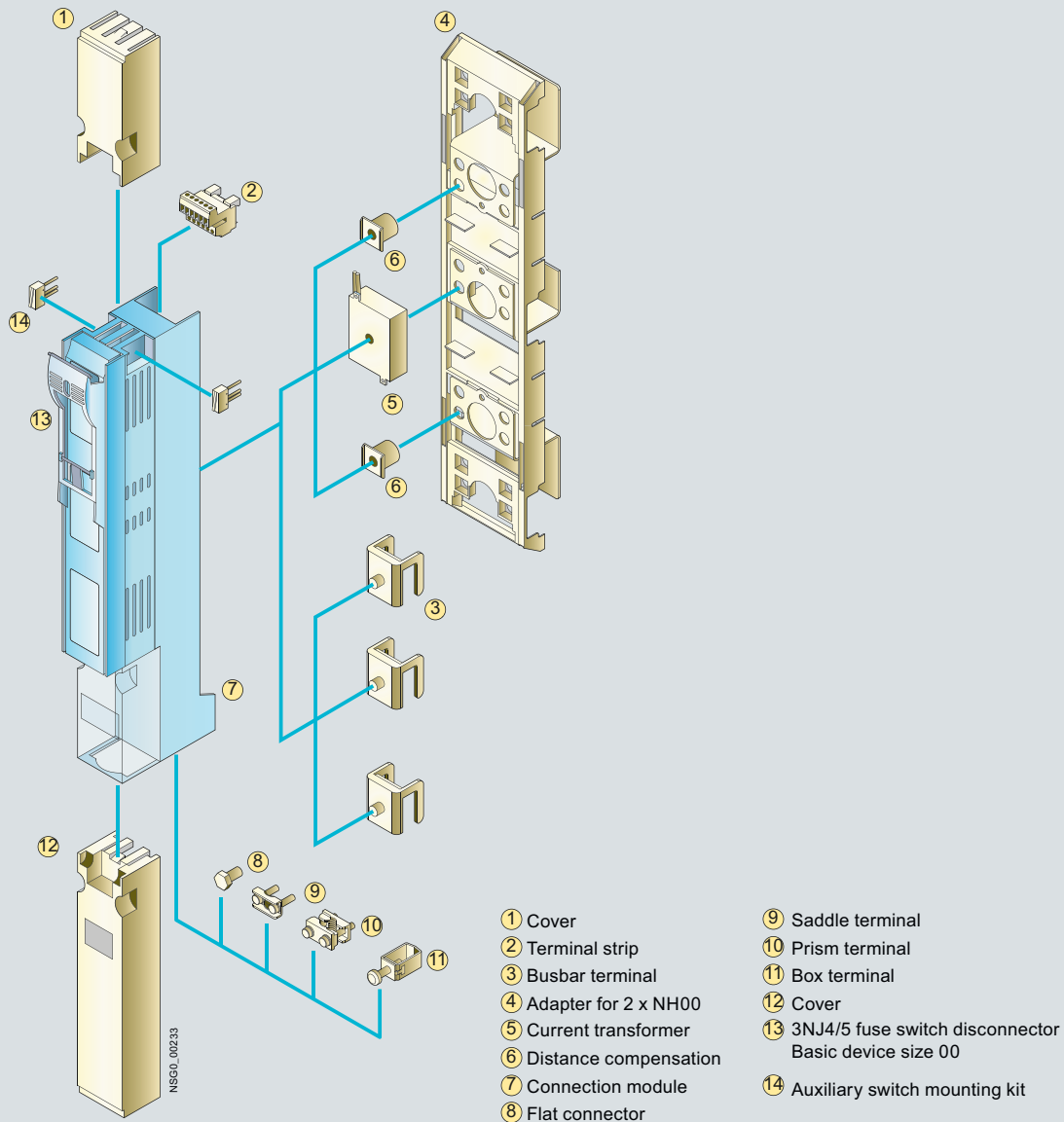
Overview of all components and accessory parts: 3NJ4/3NJ5 in size 00

3NP, 3NJ4, 3NJ5 Fuse Switch Disconnectors

3NJ4, 3NJ5 In-Line Fuse Switch Disconnectors up to 1250 A

General data

Overview of all components and accessory parts: 3NJ4/3NJ5 in sizes 1 to 3

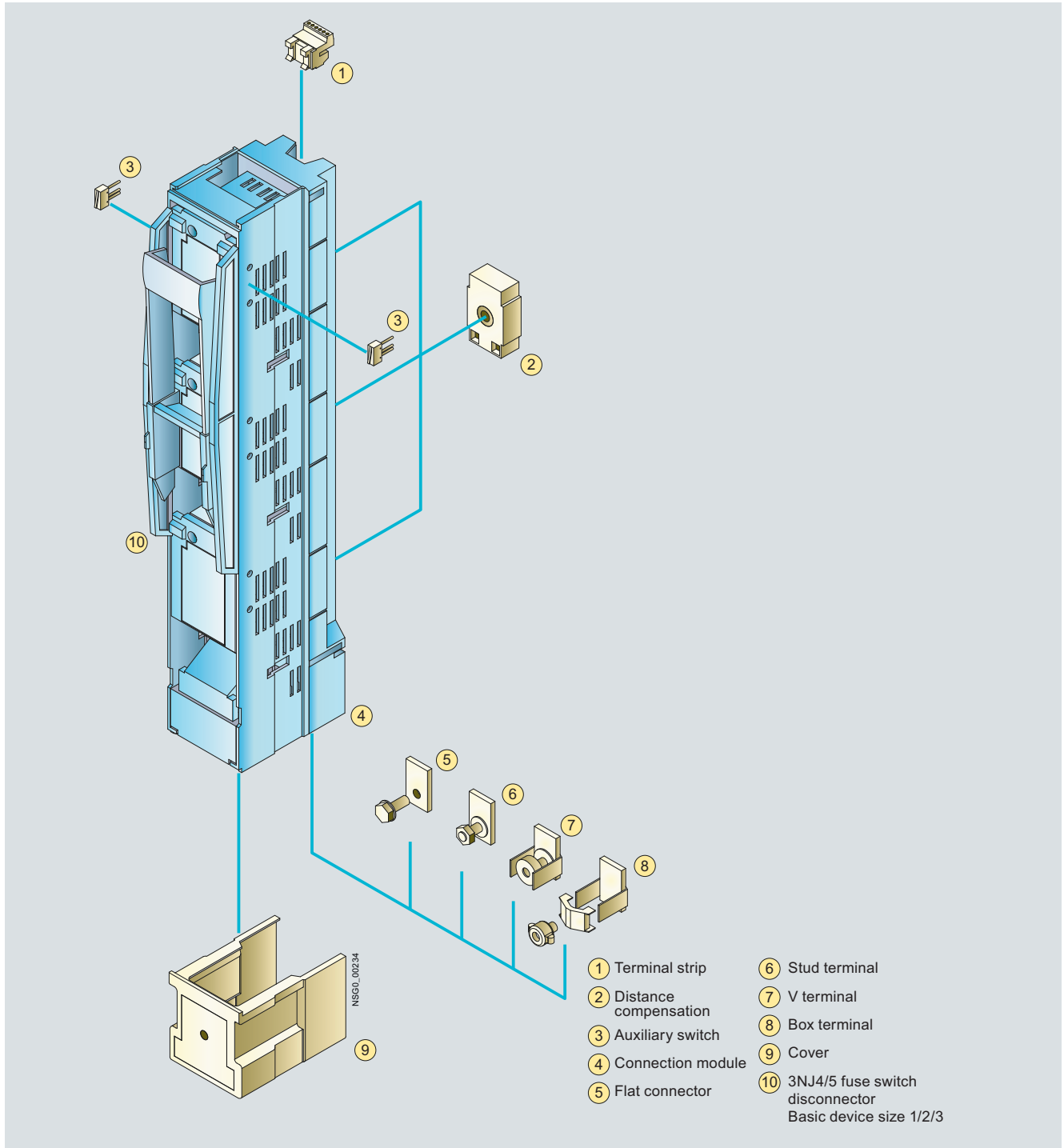

3NP, 3NJ4, 3NJ5 Fuse Switch Disconnectors

3NJ4, 3NJ5 In-Line Fuse Switch Disconnectors up to 1250 A

General data

Design

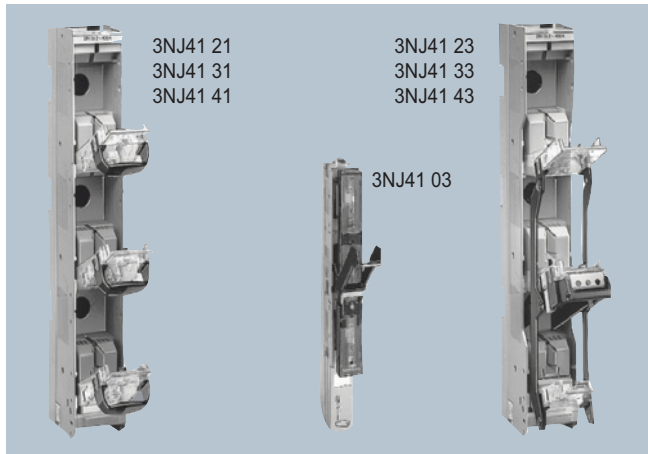

3NJ41 in-line fuse switch disconnectors

SENTRON 3NJ4/5 in-line fuse switch disconnectors are designed – like the complete SENTRON 3NJ series – for mounting on 185 mm busbar systems. They are available in the following sizes and versions:

- Size 1 for 250 A, 1- or 3-pole switchable
- Size 2 for 400 A, 1- or 3-pole switchable
- Size 3 for 630 A, 1- or 3-pole switchable
- Size 4a for 1250 A, 1-pole switchable

The size 00 for 160 A, 3-pole switchable in-line fuse switch disconnectors are available for 100 mm busbar center-to-center spacing and only as a special version for 185 mm busbar center-to-center spacing.

Instead of one size 1 to 3 in-line fuse switch disconnectors, two size 00 disconnectors with an adapter and masking frame can be used (see [Accessories](#)) on a 185-mm busbar system.

The swiveling mechanism with 3-pole switchable disconnectors of sizes 1 to 3 is lockable and ensures simultaneous switching of all three phases.

For size 4 the following versions are available in addition to the standard version:

- a slim version ($W \times H = 248 \times 775$ mm)
 - a special version ($W \times H = 147 \times 1115$ mm)
- (delivery possibilities on request).

All SENTRON 3NJ4/5 in-line fuse switch disconnectors are fed by way of the busbars. The outgoing current is transported by cable, see adjacent graphic "Terminal positions".

With SENTRON 3NJ41 in-line fuse switch disconnectors it is possible to choose between having the cable connection on top or on bottom (standard version) by turning the contact carrier. The top part of these switch disconnectors can be removed completely. This ensures easy mounting.

Inspection holes

All SENTRON 3NJ4/5 in-line fuse switch disconnectors are equipped – like the complete SENTRON 3NJ series – with voltage inspection holes for voltage testing.

Mounting position

The SENTRON 3NJ4/5 in-line fuse switch disconnectors can be mounted vertically or horizontally. When mounted horizontally, however, system-specific reduction factors and the coincidence factor (EN 60439-1 4.7 rated load factor) according to the applicable system regulations must be observed.

Terminals

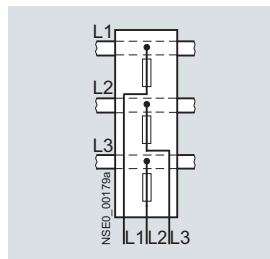

Terminal position

Integration

Assembly kits as well as TTA modules and partly equipped side-by-side cabinets are available for installation in the SIKUS 3200 (8GG) modular distribution board system; see [Chapter "SIVACON Power Distribution Boards, Busway and Cubicle Systems" --> "Components for Distribution Systems"](#).

Installation in SIKUS Universal (8GF) is also possible. Please inquire.

3NP, 3NJ4, 3NJ5 Fuse Switch Disconnectors

3NJ4, 3NJ5 In-Line Fuse Switch Disconnectors up to 1250 A

General data

Technical specifications

Standards		IEC/EN 60947-1, IEC/EN 60947-3							
		3NJ41 0 3NJ5 0	3NJ41 2	3NJ41 3	3NJ41 4	3NJ41 8	3NJ41 5	3NJ56	
Type									
Conventional thermal current									
Free air $I_{th}^{1)}$	A	160	250	400	630	910	1000	1250	
Enclosed $I_{the}^{2)}$	A	160	225	360	567	--	--	--	
Rated insulation voltage U_i		V	750	1000	1000	1000	690	1000	1000
Rated operational voltage U_e		40 Hz ...60 Hz V AC	690	690	690	690	400	690	690
Rated conditional short-circuit current with fuses									
At 40 Hz to 60 Hz 690 V AC	kA (rms value)	80/50	110	110	110	50	110	80	
Max. rated current I_n of the fuses	A	160	250	400	630	910	722	1250	
Permissible let-through current of the fuses	kA (peak value)	15	28	39	52	53	--	80	
For fuse links acc. to IEC 60269-2 or isolating links	Size/A	00/160	1/250	1 and 2/250 and 400	2 and 3/400 and 630	3/910	3/722	4a/1250	
Rated operational current I_e									
At 400 V AC	AC-22B	A	160	250	400	630	910	1000	1250
500 V AC	AC-22B	A	160	250	400	630	--	1000	1250
690 V AC	AC-21B	A	160	250	400	630	--	1000	1250
690 V AC	AC-22B	A	100	200	315	500	--	600	--
220 V DC	DC-21B	A	160	250	400	630	--	--	--
Rated breaking capacity									
At 500 V AC	p.f. = 0.65	A	480	750	1200	1890	--	2400	3750
690 V AC	p.f. = 0.65	A	380	600	945	1500	--	--	--
220 V DC	L/R = 1 ms	A	240	375	600	945	--	--	--
Capacitive switching capacity		kvar	50 ... 60	105 ... 115	155 ... 185	250 ... 300	--	--	--
Rated short-time withstand current I_{CW}		kA (rms value)	14.5	14.5	14.5	14.5	14.5	14.5	14.5
Permissible ambient temperature		°C	-25 ... +55						
Mechanical endurance		Operat- ing cycles	1400	1400	800	800	800	800	800
Electrical endurance		Operat- ing cycles	200	200	200	200	100	100	100
Degree of protection									
With closed fuse carrier, with terminal cover and peripheral cover			IP30	IP30	IP30	IP30	IP30	IP30	IP10
With open fuse carrier			IP10	IP10	IP10	IP10	IP10	IP10	IP00
Power loss of the main current paths at I_{th}		W	18	23	54	110	260	300	300
Main conductor connections									
Terminal screws			M8	M10	M12	M12	2 × M12	2 × M12	M16
Flat bars	mm	24	42	42	42	80	80	80	
Cable lug, max. conductor cross-section (stranded)	mm ²	95	240	240	240 ³⁾	2 × 240	2 × 240	2 × 300	
Tightening torque	Nm	12 ... 15	30 ... 35	35 ... 40	35 ... 40	35 ... 40	35 ... 40	50 ... 60	
Clamp/V terminals		mm ²	1.5 ... 70	25 ... 300	25 ... 300	25 ... 300	--	--	
Fixing screws			M8	M12	M12	M12	M12	M16	
Required tightening torque for mounting on busbars	Nm	16 ... 18	35 ... 40	35 ... 40	35 ... 40	35 ... 40	35 ... 40	50 ... 60	

1) When several devices are used next to each other, the load factor according to EN 60439-1 Table 1 must be observed.

2) Required enclosure volume is at least 0.185 m³.

3) A special assembly kit is required for connection of 2 × 240 mm²; delivery on request.

3NP, 3NJ4, 3NJ5 Fuse Switch Disconnectors

3NJ4, 3NJ5 In-Line Fuse Switch Disconnectors up to 1250 A

1-pole switchable

Dimensional drawings

3NJ50 13, 160 A
1-pole switchable

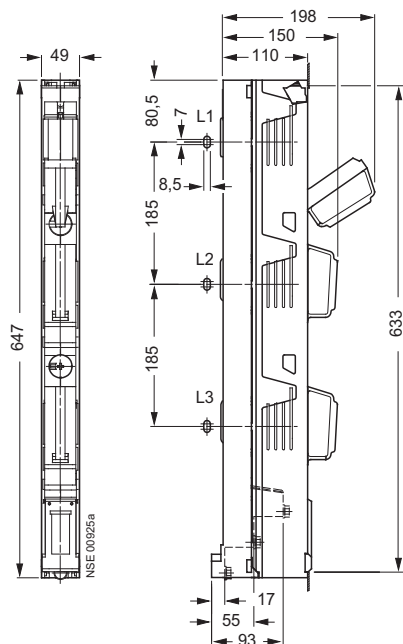

3NJ41 .1-3, 250 to 630 A
1-pole switchable

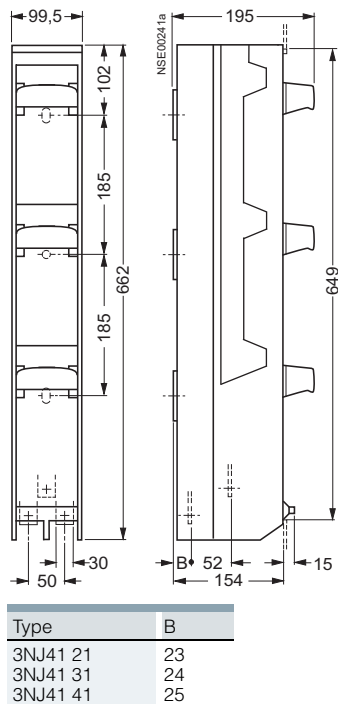

3NJ56 43, 1250 A
1-pole switchable
for 185 mm center-to-center spacing

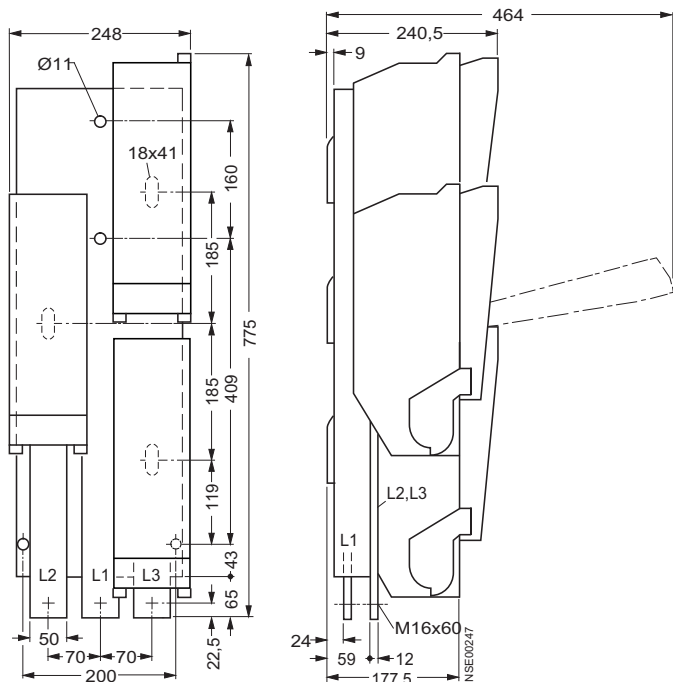

Panel cut-out
with flush mounting for 3NJ56 43

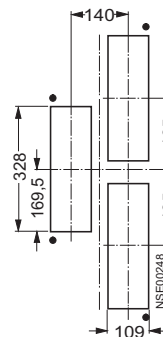

3NP, 3NJ4, 3NJ5 Fuse Switch Disconnectors

3NJ4, 3NJ5 In-Line Fuse Switch Disconnectors up to 1250 A

3-pole switchable

Dimensional drawings

3NJ41 03-3BF02
3-pole switchable

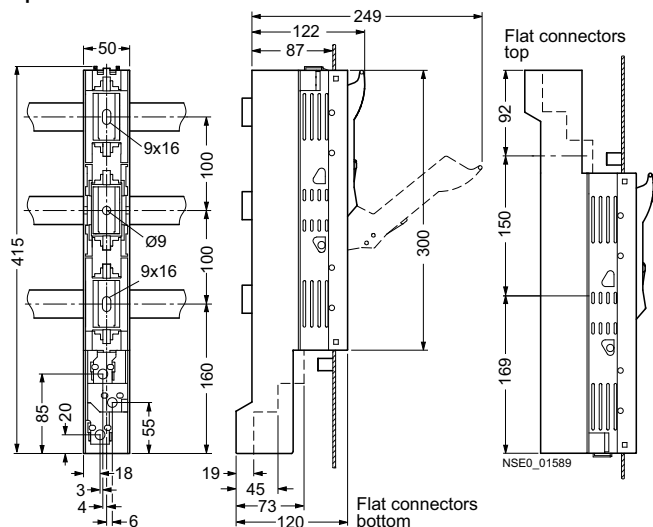

3NJ41 03-3BR02
3-pole switchable

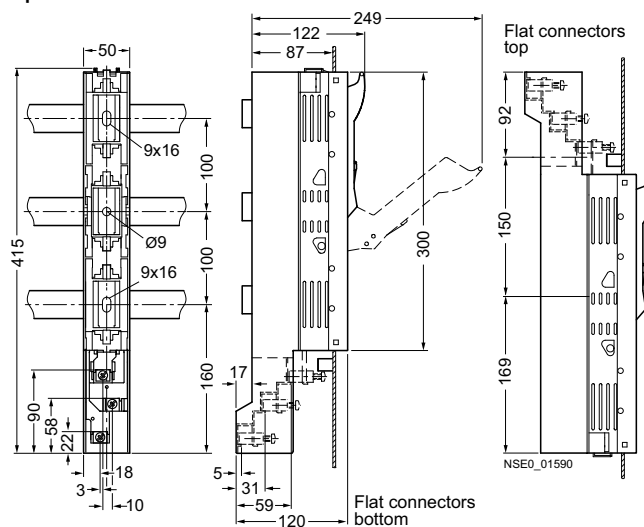

3NJ41 .3-3,
250 to 1000 A
3-pole switchable

"ON" position

"OFF" position
A unlocked
B locked

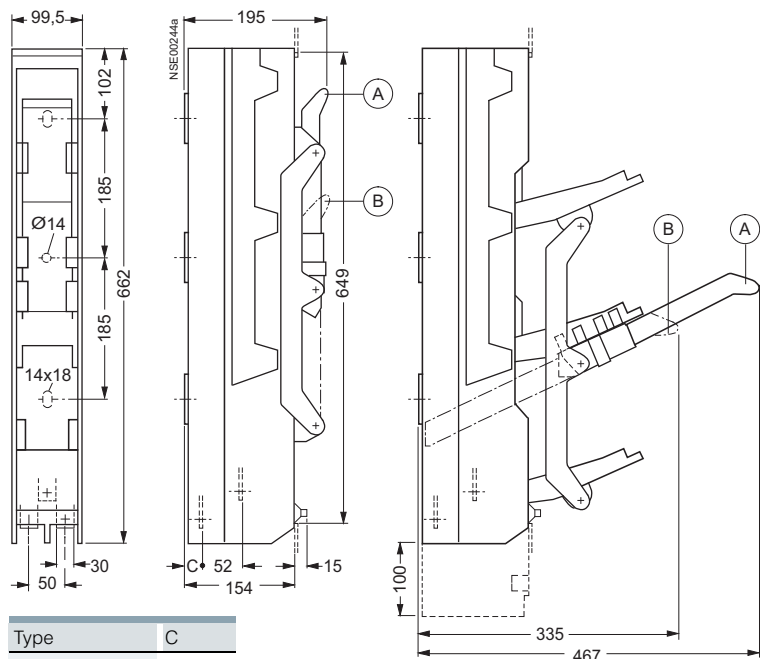

Type	C
3NJ41 23	23
3NJ41 33	24
3NJ41 43	25
3NJ41 53	25
3NJ41 83	25

Mounting of the in-line fuse switch disconnectors on busbars for 100 mm center-to-center spacing

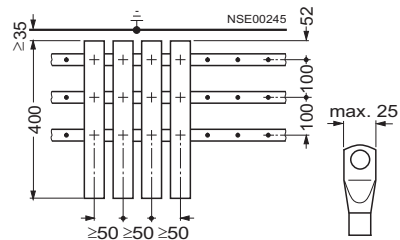

Mounting of the in-line fuse switch disconnectors on busbars for 185 mm center-to-center spacing
Minimum distance between the conductive parts of all bars: 100 mm

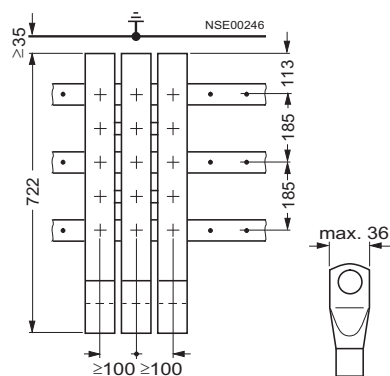

3NP, 3NJ4, 3NJ5 Fuse Switch Disconnectors

3NJ4, 3NJ5 In-Line Fuse Switch Disconnectors up to 1250 A

Accessories

Dimensional drawings

3NJ49 12-2AA00
blinking cover
50 mm wide
for panel cut-out

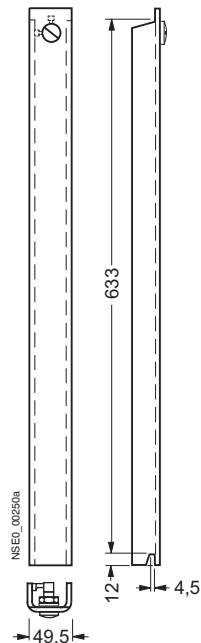

3NJ49 12-3BA01
blinking cover for busbar
100 mm wide
for 185 mm busbars

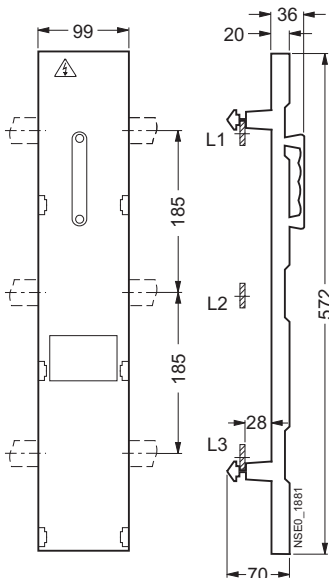

3NJ49 12-3CA00
blinking cover for busbar
50 mm wide
for 100 mm busbars

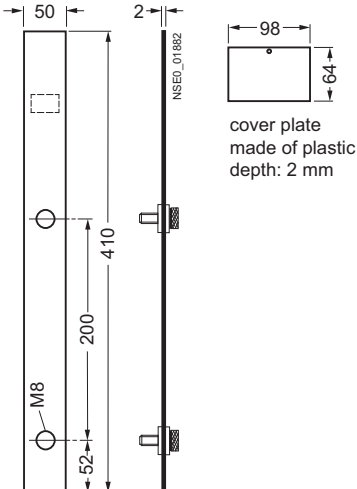

3NJ59 74-0AB
busbar support

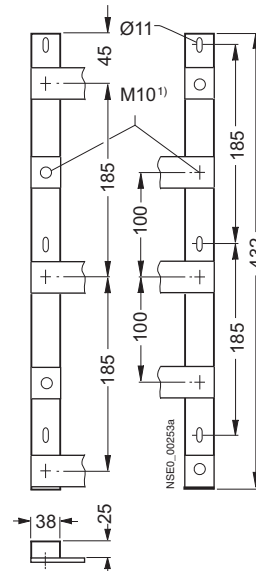

Width of busbars as required, but minimum clearance of 20 mm to the next busbar or conductive parts

1) Maximum screw-in length 14 mm, tightening torque 30 Nm.

3NJ49 11-3AA00
busbar terminal

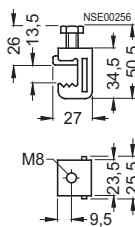

3NJ49 18-0EA00
adapter
for 60 mm busbar center-to-center spacing

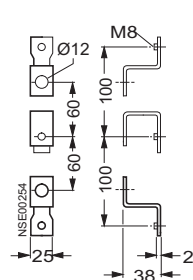

3NJ49 18-0DA02
adapter
for 185 mm busbar center-to-center spacing

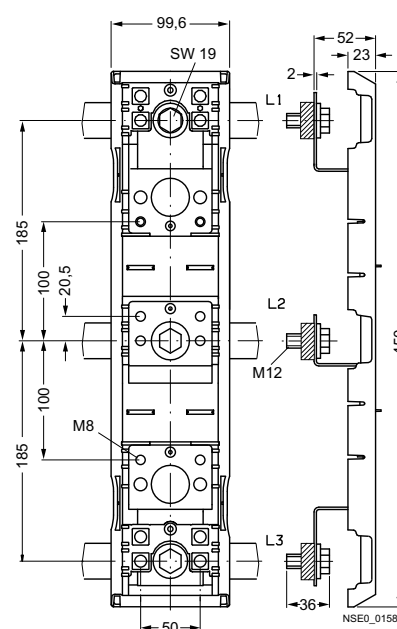

3NJ49 12-1DA02
cover (long)
for 185 mm busbar center-to-center spacing

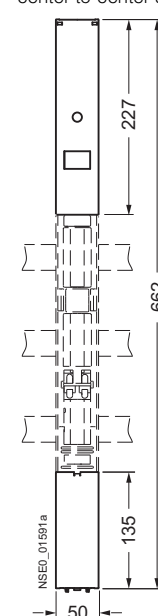

8US Busbar Systems

General data

Overview

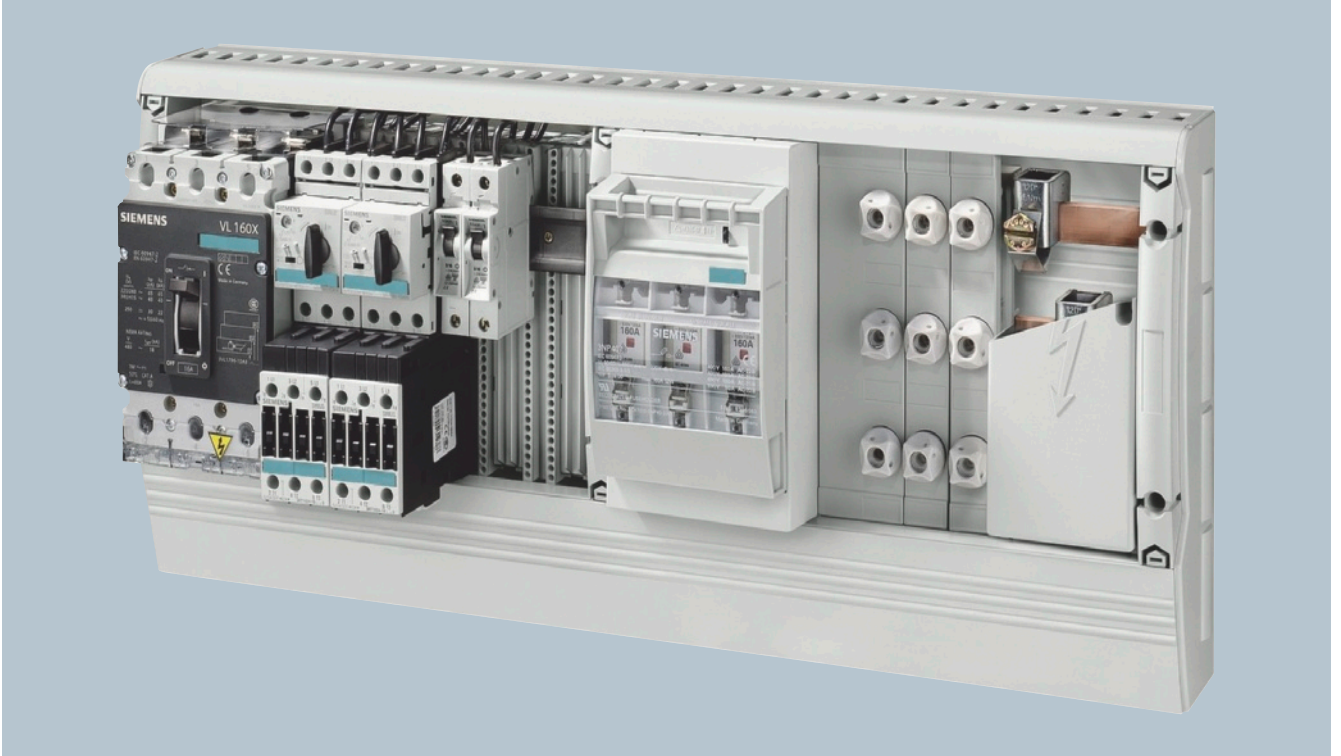

Design

8US busbar systems with 40 mm and 60 mm busbar center-to-center spacing as well as flat copper profiles have now become firmly established on the world market. The permissible busbar temperature is a decisive factor when dimensioning the busbars. The busbar temperature is dependent on the current and the current distribution, on the busbar cross-section and the busbar surface, on the position of the busbars, convection and the ambient temperature. The values stated in the following table can only be considered as guide values because the conditions vary with each location. The values are based on uninterrupted current over the whole busbar length.

The busbar runs prove most advantageous when the incoming supply is centrally located and the load is distributed symmetrically on both sides.

8US busbar systems are designed for horizontal mounting of the busbars.

Function

Short-circuit strength

The short-circuit strength of the busbar system is dependent on the distance of the busbar supports and on the busbar cross-section.

The short-circuit strength of the whole system is dependent on the short-circuit strength of the busbars and of the adapters with circuit breakers or switch disconnectors (see "Molded case circuit breakers (MCCB)" and "Switch disconnectors").

If one of these values is lower than the prospective short-circuit current at the place of installation, a current-limiting protective device has to be mounted upstream of the 8US busbar system. This may also be mounted as a feeder circuit breaker on the busbar system itself.

Overview



The 40 mm busbar system is used in machinery and plant engineering, in motor control centers and in power distribution systems of the low performance range up to 400 A.

The busbar cross-sections are adapted to the rated currents and are available in the sizes 12 x 5 mm, 12 x 10 mm, 15 x 5 mm and 15 x 10 mm. The basic system is configured without covers. If touch protection is required, this is possible with busbar covers.

An optimized spectrum of busbar adapters and device holders offers numerous adaptation and mounting options. Terminals round off the product range of the 40 mm busbar system.

8US Busbar Systems

40 mm Busbar Systems

Base assemblies

Overview

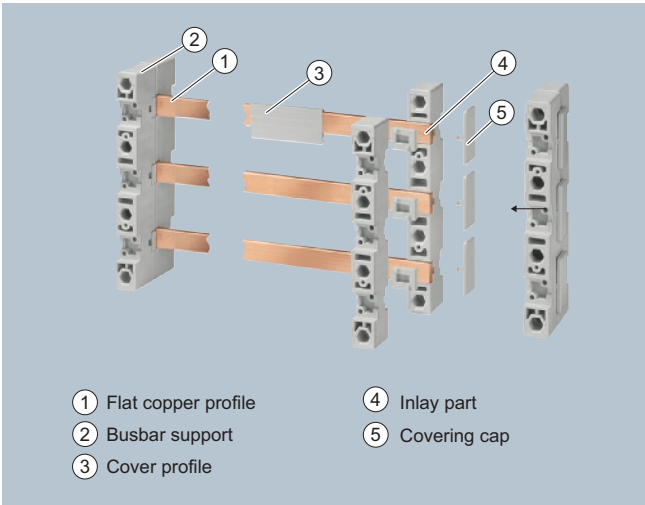

Dimensional drawings

8US19 03-3AB00

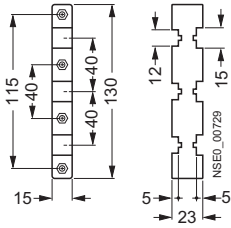

8US19 03-5AA00

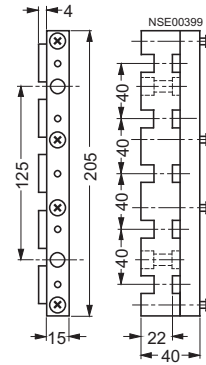

8US Busbar Systems

40 mm Busbar Systems

Infeed and connection components

Overview

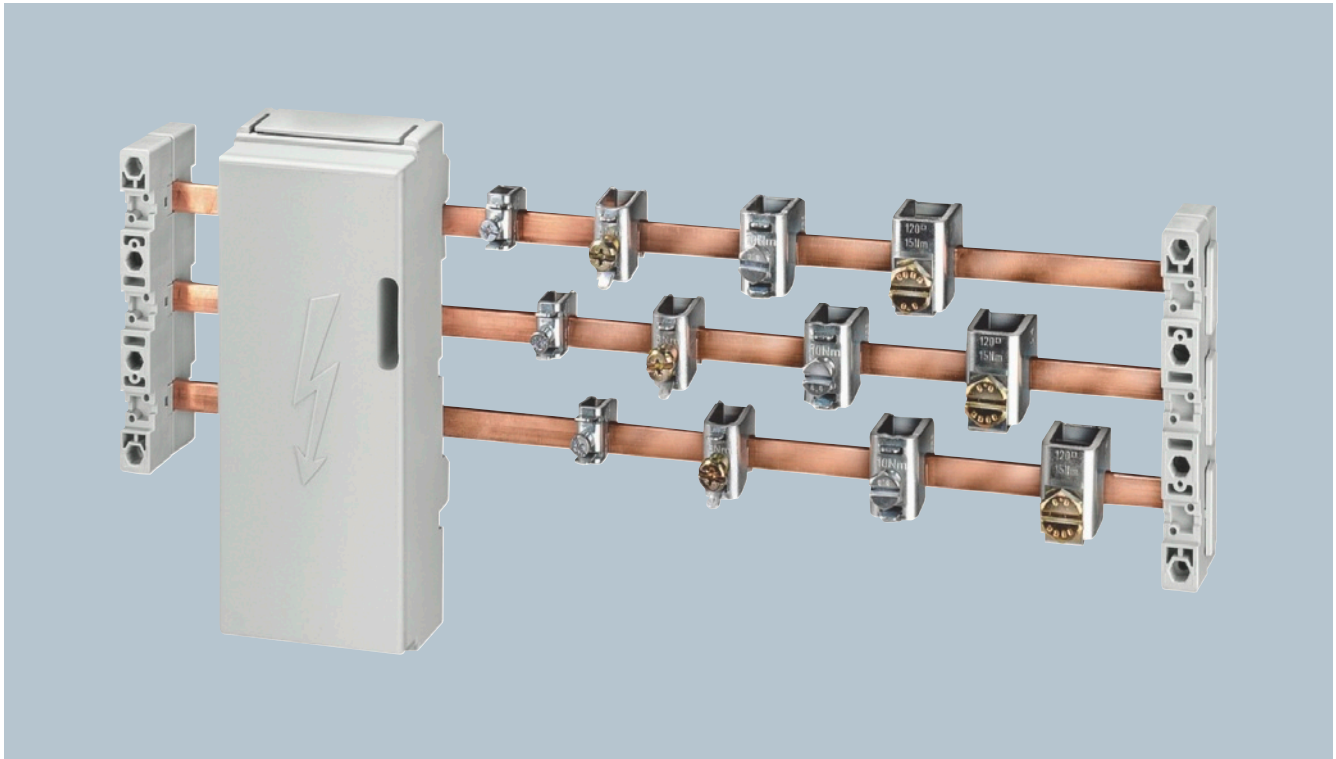

Dimensional drawings

8US19 21-2..0.

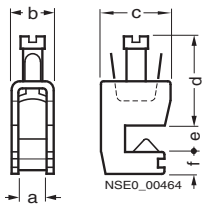

Type	a	b	c	d	e	f
8US19 21-2AA0.	7.5	11.5	22.5	25	5	10
-2AB0.	10.5	15.5	29	35	5	10
-2AC0.	17	23.5	36	55	5	12
-2AD0.	14.5	20.5	32	42	5	12
8US19 21-2BA0.	7.5	11.5	22.5	25	10	10
-2BB0.	10.5	15.5	29	35	10	10
-2BC0.	17	23.5	36	55	10	12
-2BD0.	14.5	20.5	32	42	10	12

8US19 22-1GA00

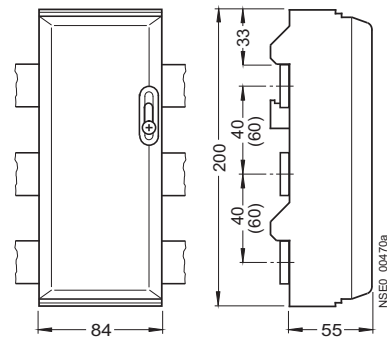

8US Busbar Systems

40 mm Busbar Systems

Busbar adapters and device holders

Overview

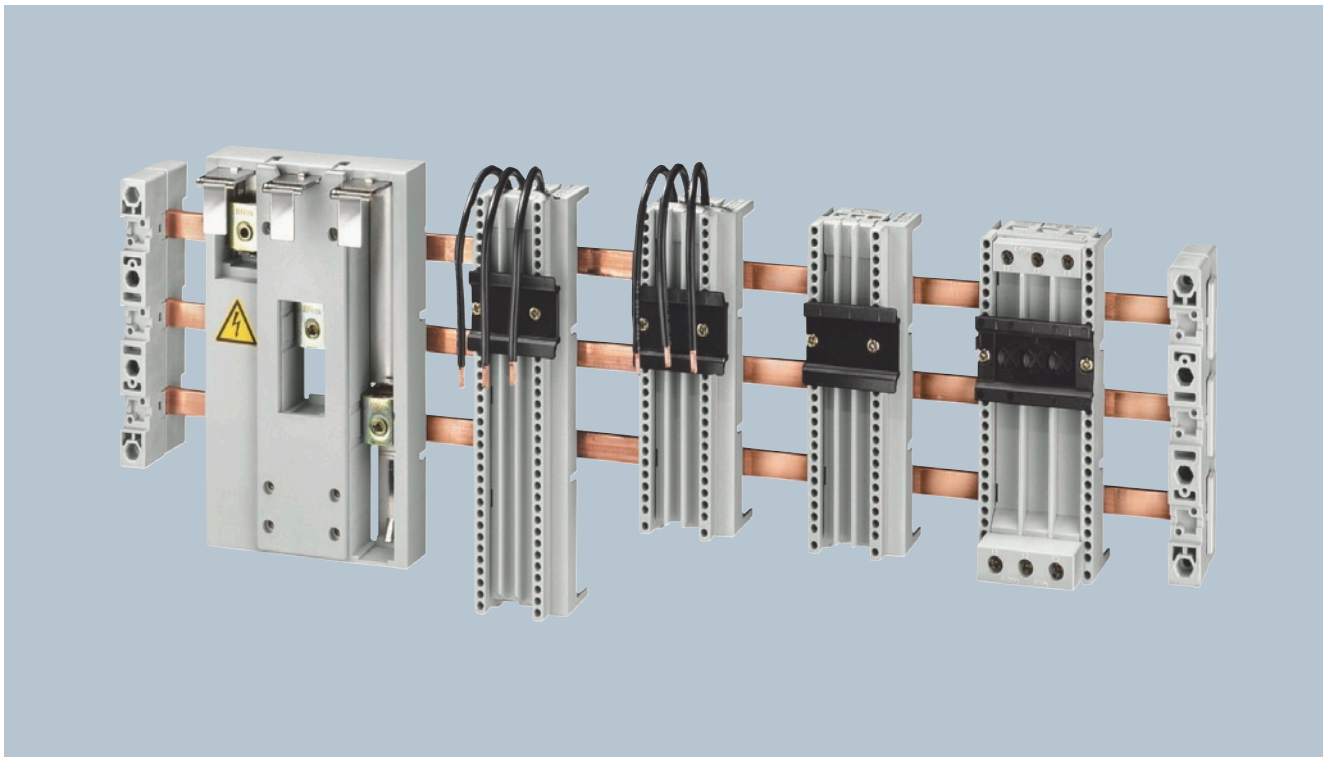

Dimensional drawings

8US10 51-5CM47

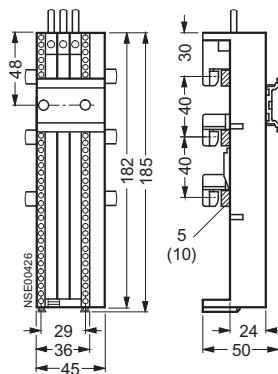

8US10 51-5DJ07

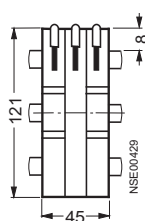

8US10 51-5DK07

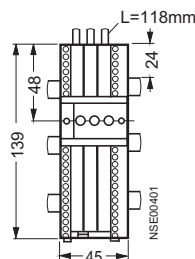

8US10 51-5DM07

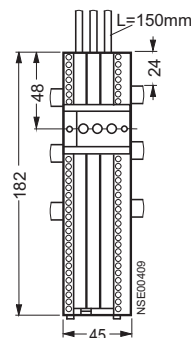

8US10 61-5DJ07

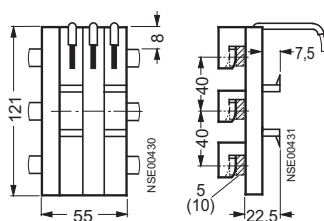

8US10 61-5FK08

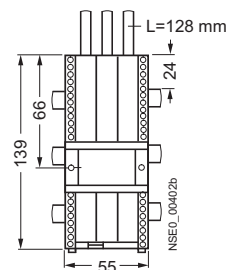

8US10 61-5FM08

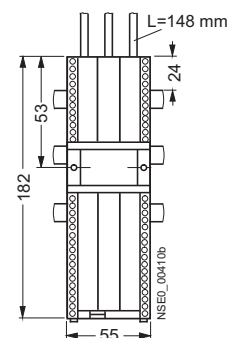

8US10 61-5FP08

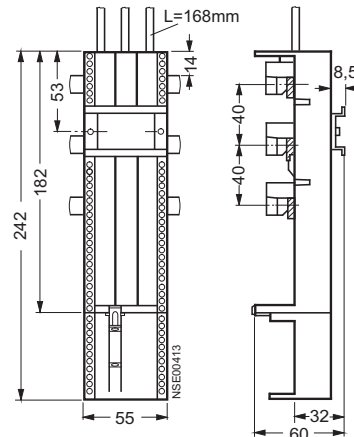

8US Busbar Systems

40 mm Busbar Systems

Busbar adapters and device holders

8US10 11-4SL01

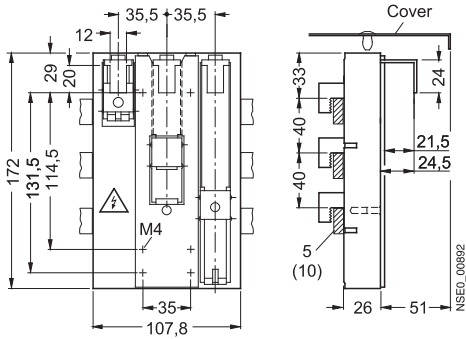

8US10 11-4TM00

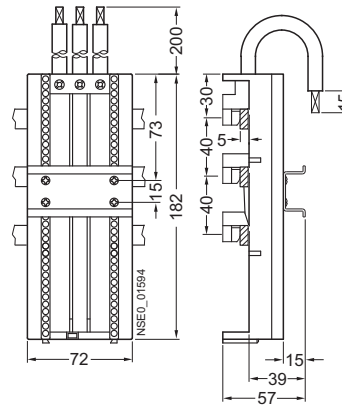

8US11 11-4SM00

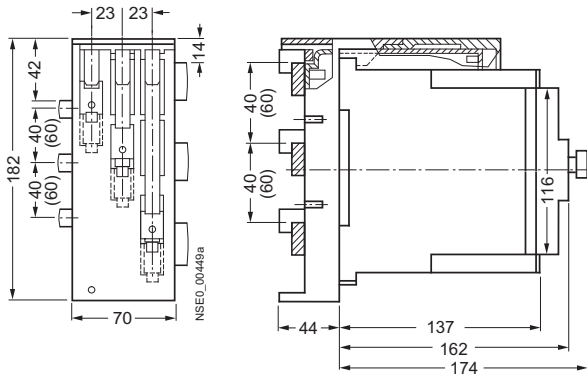

8US10 50-5AK00

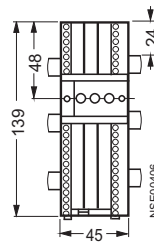

8US10 50-5AM00

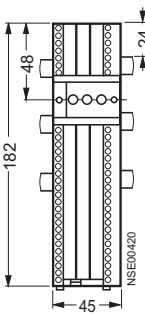

8US10 50-5RK07

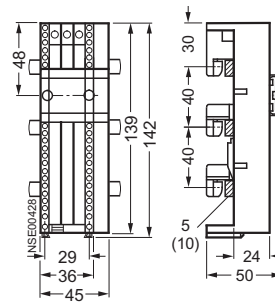

8US10 50-5RM07

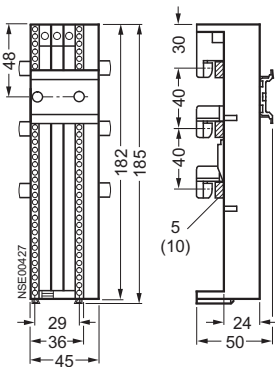

8US Busbar Systems

40 mm Busbar Systems

Busbar adapters and device holders

8US10 60-5AK00

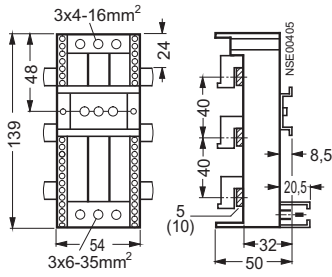

8US10 60-5AK08

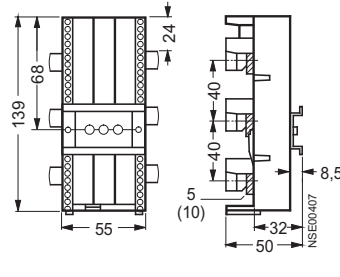

8US10 60-5AM00

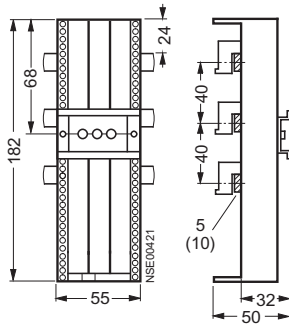

8US19 98-2BK00

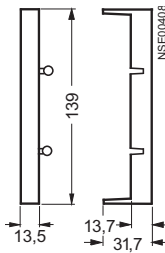

8US19 98-2BM00

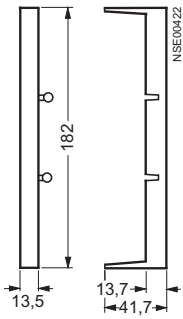

Dimensional drawings

8US19 21-2BF00

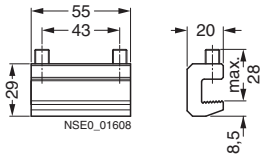

8US19 98-1BA00

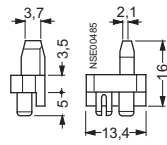

8US19 98-1CA00

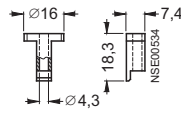

8US19 98-1DA00

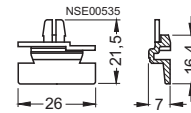

8US19 98-4AA00

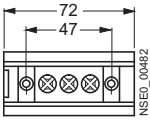

8US19 98-7CA08

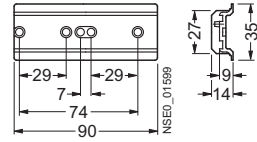

8US19 98-7CA10

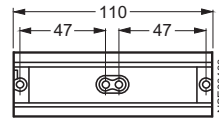

8US19 98-7CA15

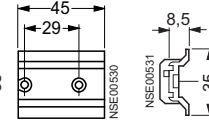

8US19 98-7CA16

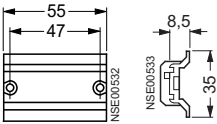

8US19 98-8AM07

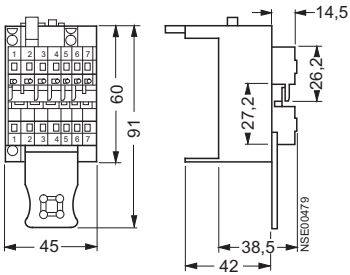

8US19 98-8AA10

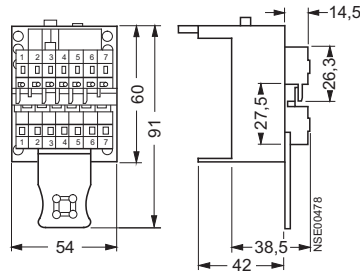

8US Busbar Systems

60 mm Busbar Systems

General data

Overview

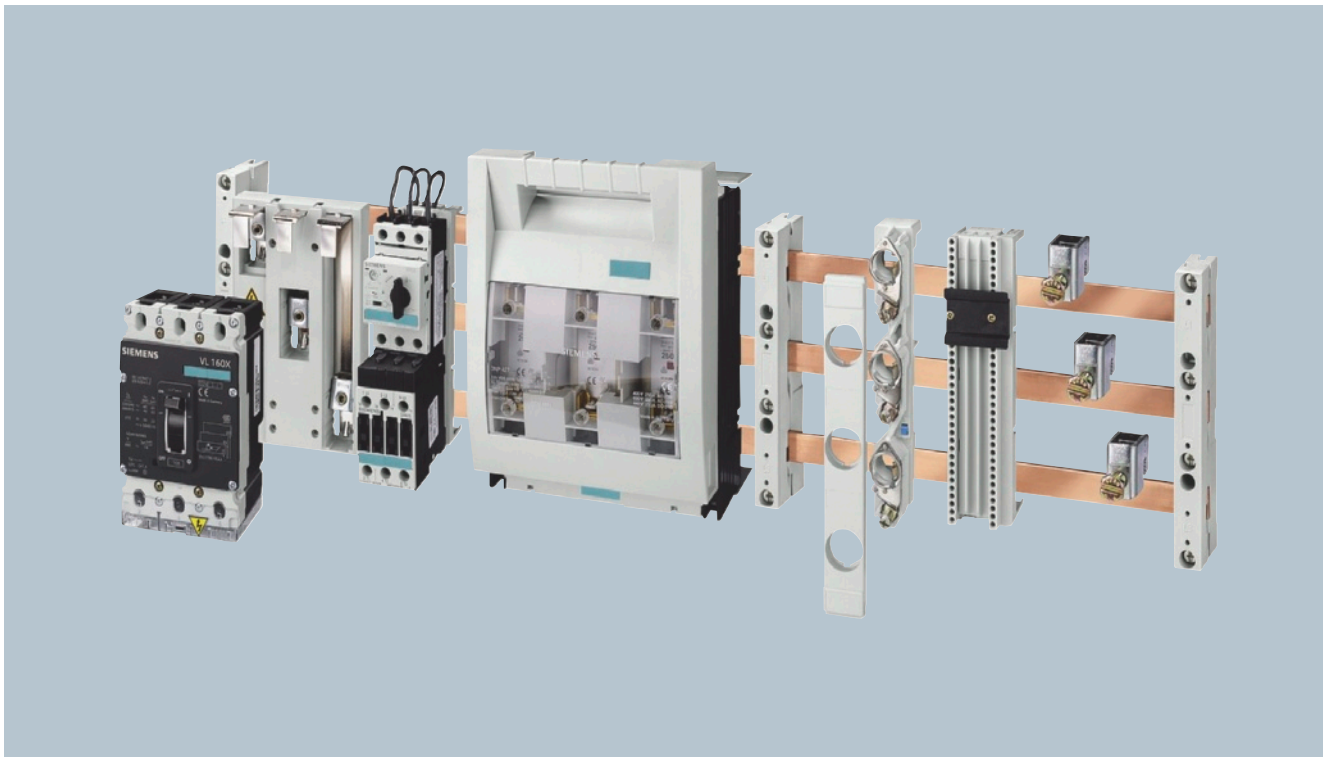

The 60 mm busbar system is used preferably in control cabinet installation, in motor control centers and in power distribution systems of the medium performance range (630 A) and top performance range (1600 A, special profile).

The 60 mm busbar system can be used as a basic system without covers, as a partly compartmented system or as a fully compartmented system with base. The busbar cross-sections are available in the sizes 12 x 5 mm to 30 x 10 mm and as a special profile.

Busbar adapters for SIRIUS, 3VL circuit breakers, 3KA and 3KL switch disconnectors, 3NP5 fuse switch disconnectors and 3NP4 directly mountable fuse switch disconnectors offers numerous options for configuring this busbar system. Incoming feeders, terminals and other accessories open up a large range of application.

Busbars with a special profile are suitable for applications up to 1600 A. All components of the 60 mm busbar system can be fitted.

8US Busbar Systems

60 mm Busbar Systems

Base assemblies up to 630 A

Overview

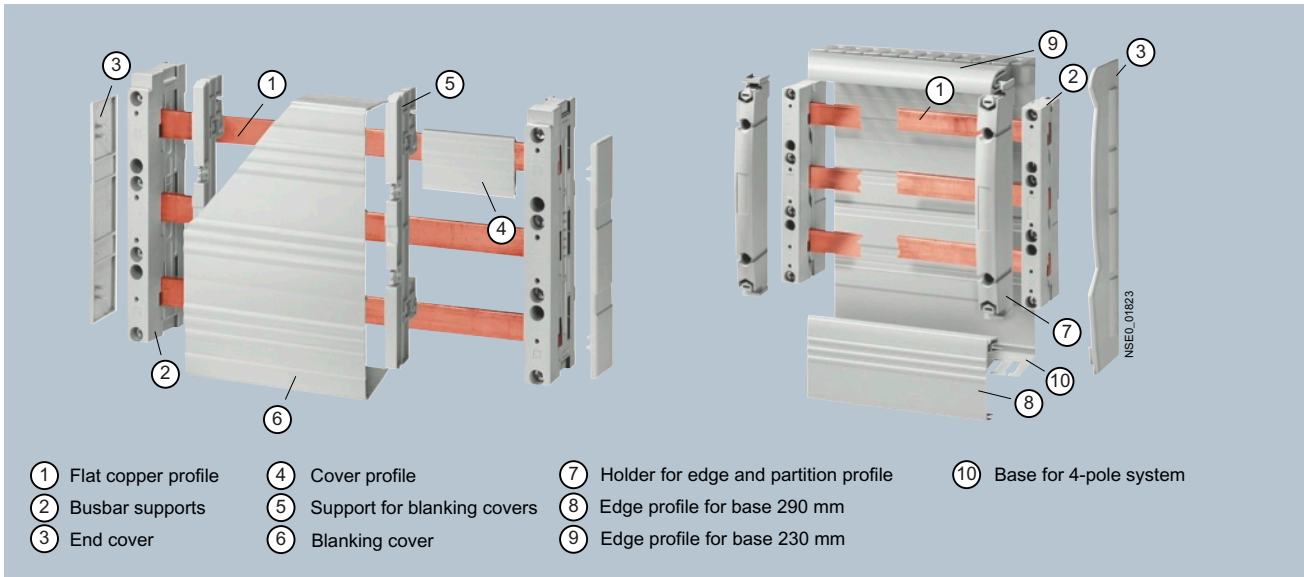

Dimensional drawings

5SH3 506

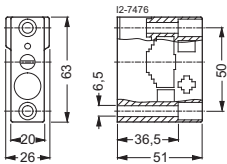

5SH3 526

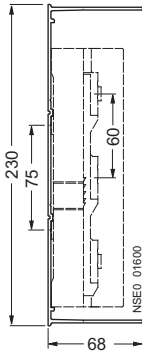

5SH3 527

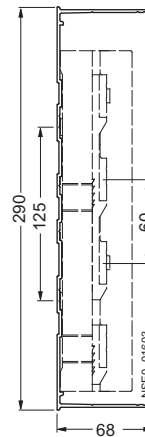

8US Busbar Systems

60 mm Busbar Systems

Base assemblies up to 630 A

5SH3 353

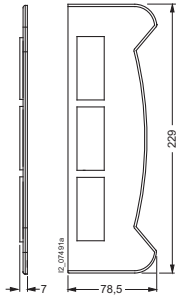

5SH3 354

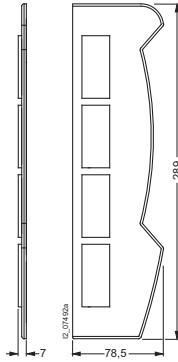

5SH3 528

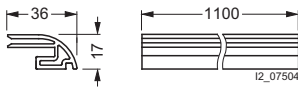

5SH3 530

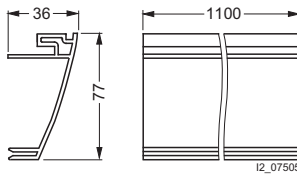

5SH3 531

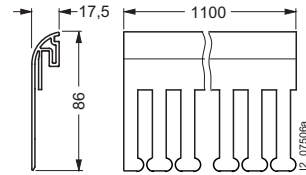

5SH3 532

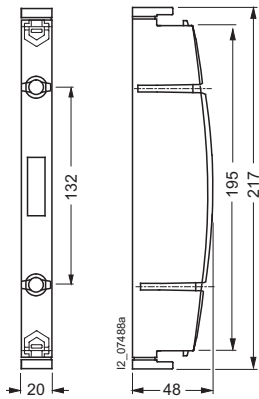

5SH3 536

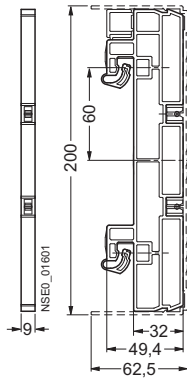

5SH3 537

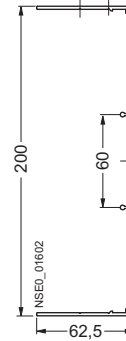

8US Busbar Systems

60 mm Busbar Systems

Base assemblies up to 630 A

8US19 22-1AB00

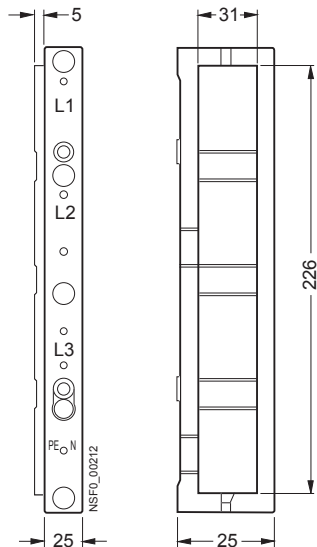

8US19 22-1AC00 with 8US19 23-3AA01

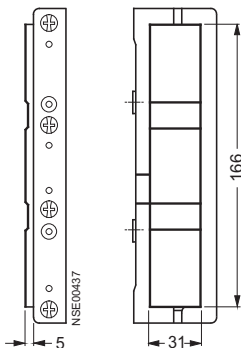

8US19 22-2AA00

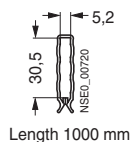

8US19 22-2BA00

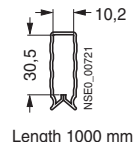

8US19 22-2CA00

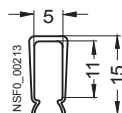

8US19 22-1HA00

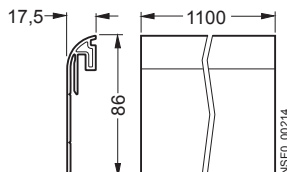

8US19 23-2AA01

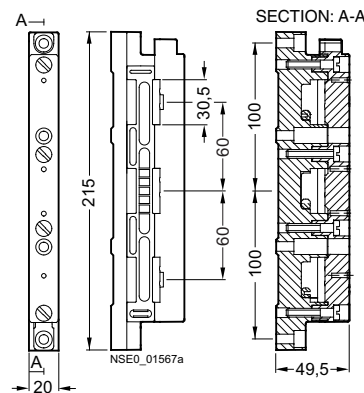

8US19 23-3AA01

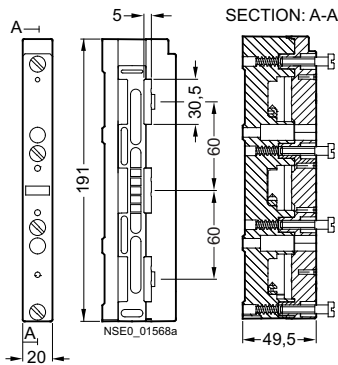

8US19 23-4AA00

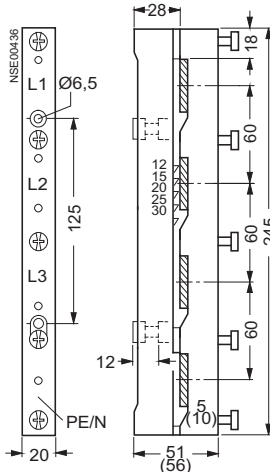

8US19 23-5AA00

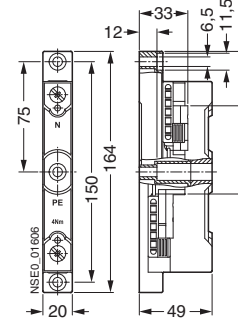

8US Busbar Systems

60 mm Busbar Systems

Base assemblies up to 1600 A

Overview

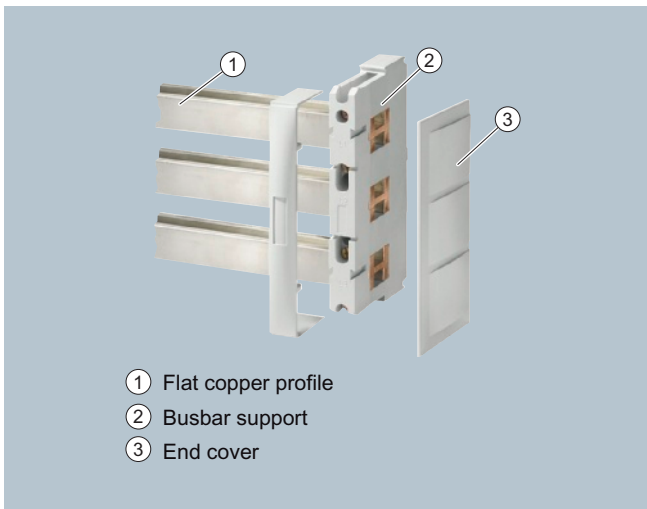

Dimensional drawings

8US19 22-2DA00

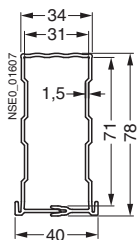

8US19 48-2AA00

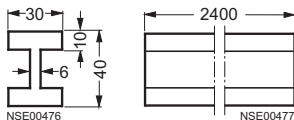

8US19 43-3AA00

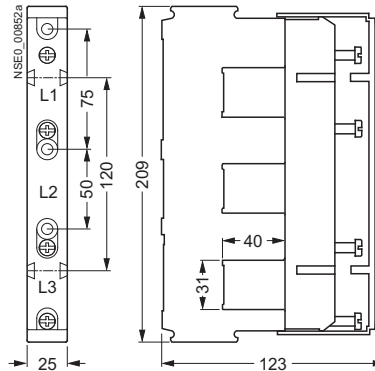

17

8US Busbar Systems 60 mm Busbar Systems

Infeed and connection components

Overview

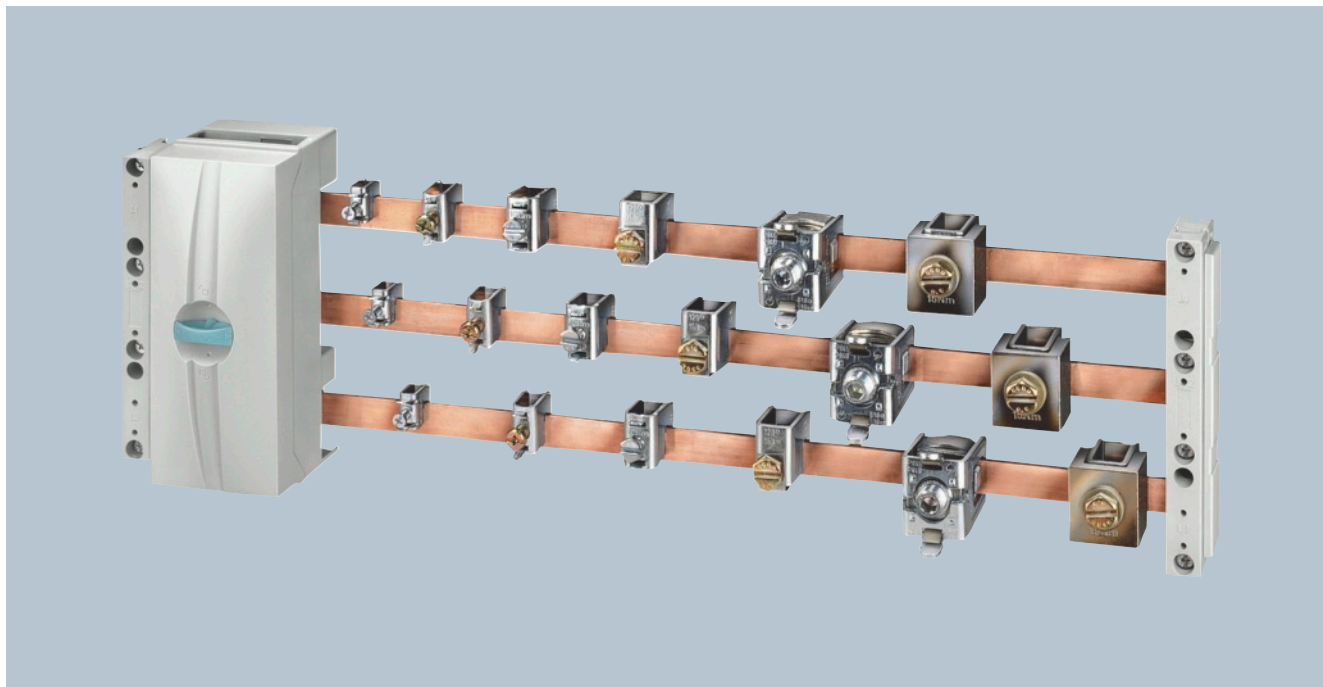

8US Busbar Systems

60 mm Busbar Systems

Infeed and connection components

Dimensional drawings

8US12 00-0AA00

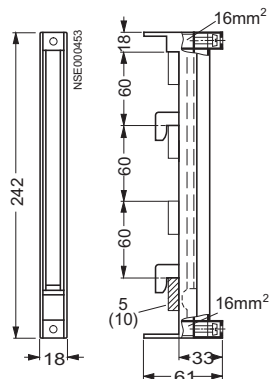

8US19 21-1AA00

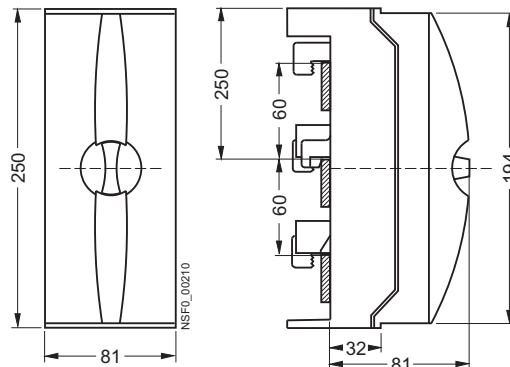

8US19 21-1BA00

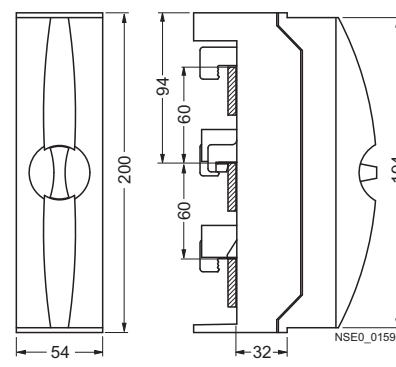

8US19 21-2..0.

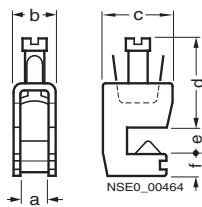

Type	a	b	c	d	e	f	Max. tightening torque
8US19 21-2AA0.	7.5	11.5	22.5	25	5	10	4 Nm
-2AB0.	10.5	15.5	29	35	5	10	6 Nm
-2AC0.	17	23.5	36	55	5	12	15 Nm
-2AD0.	14.5	20.5	32	42	5	12	10 Nm
8US19 21-2BA0.	7.5	11.5	22.5	25	10	10	4 Nm
-2BB0.	10.5	15.5	29	35	10	10	6 Nm
-2BC0.	17	23.5	36	55	10	12	15 Nm
-2BD0.	14.5	20.5	32	42	10	12	10 Nm
8US19 41-2AC00							18 Nm

8US19 41-2AC00

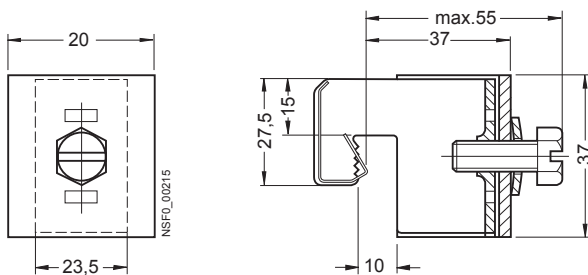

8US19 22-1GA00

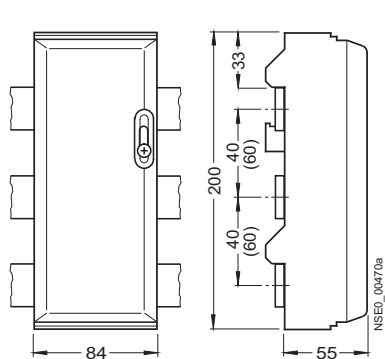

8US19 22-1GA02

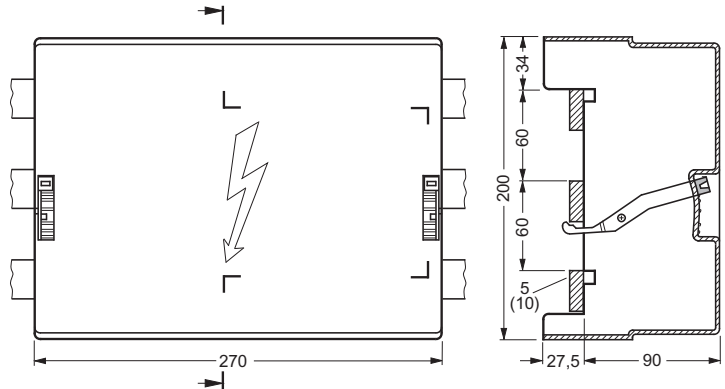

8US19 41-2AA02

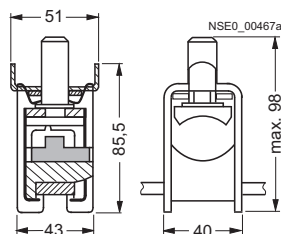

Max. tightening torque 30 Nm

8US19 41-2BA00

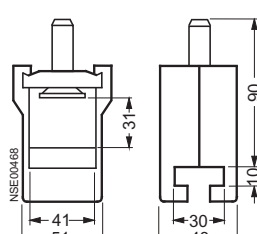

Max. tightening torque 40 Nm

8US19 41-2BB00, 8US19 41-2AA01

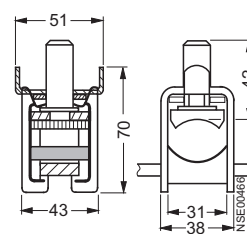

Max. tightening torque 30 Nm

8US Busbar Systems

60 mm Busbar Systems

Busbar adapters and device holders

Overview

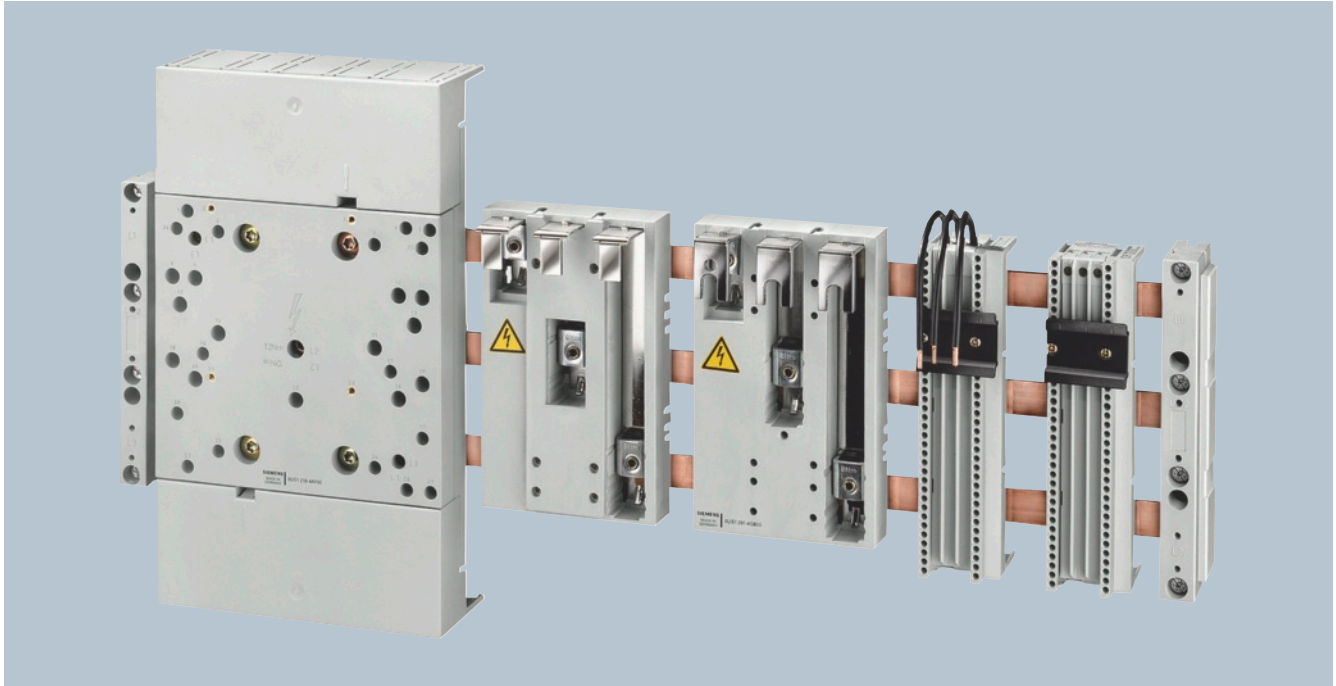

Dimensional drawings

8US11 11-4SM00

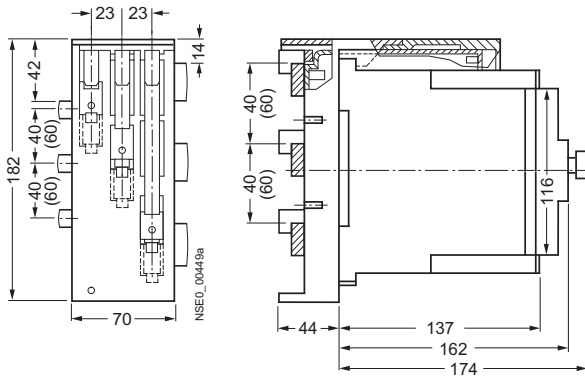

8US12 10-4AA04

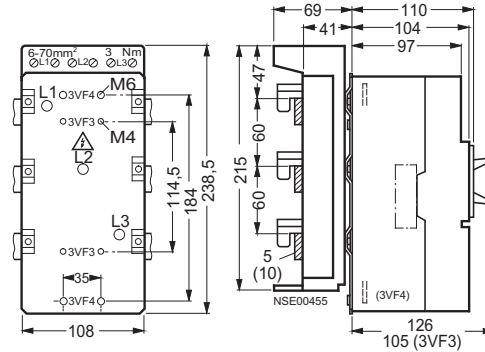

8US12 11-4SL00

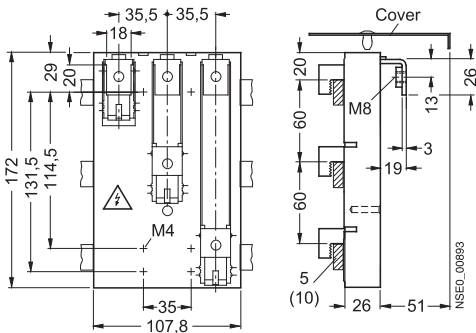

8US12 11-4SL01

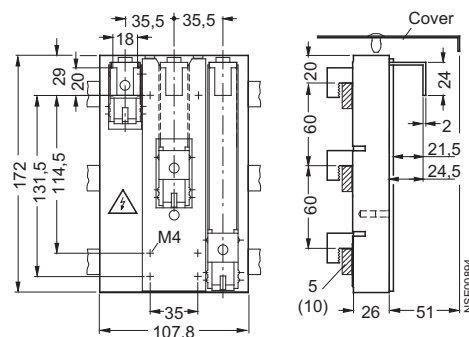

8US Busbar Systems

60 mm Busbar Systems

Busbar adapters and device holders

8US12 10-4AG00

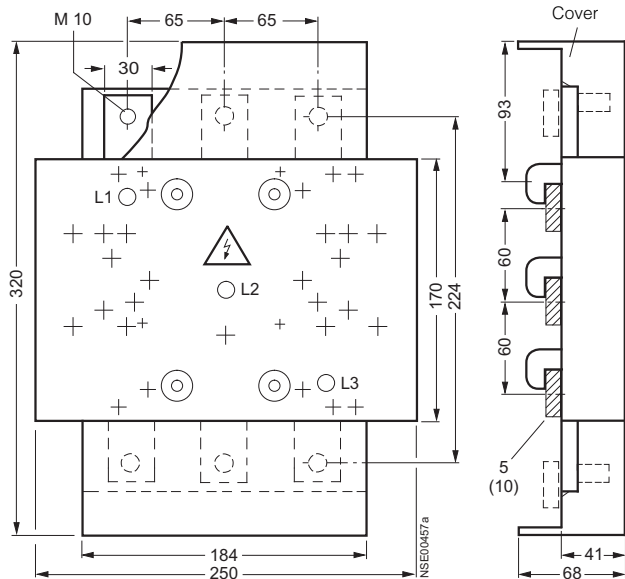

8US12 10-4AF00

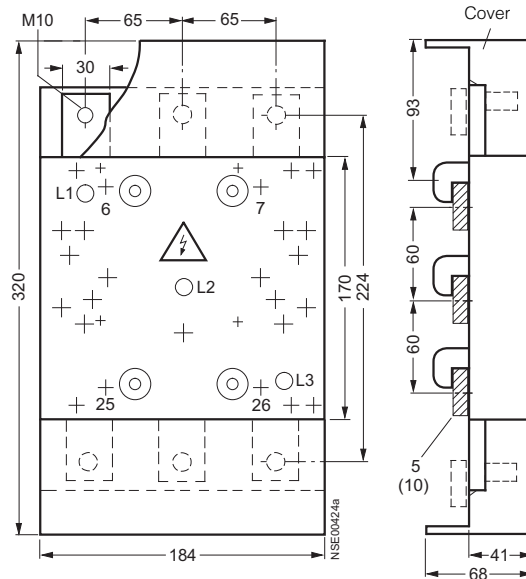

8US12 11-4TM00

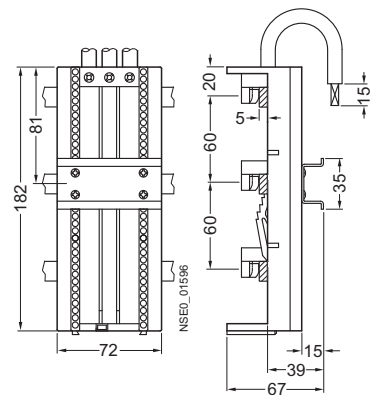

8US12 50-5AM00

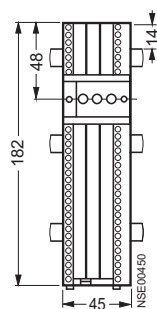

8US12 50-5RM07

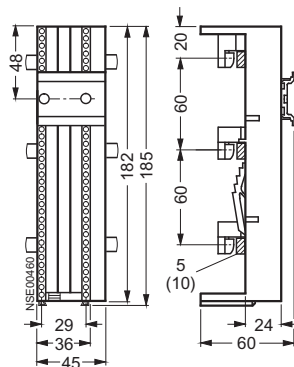

8US Busbar Systems

60 mm Busbar Systems

Busbar adapters and device holders

8US12 51-5CM47

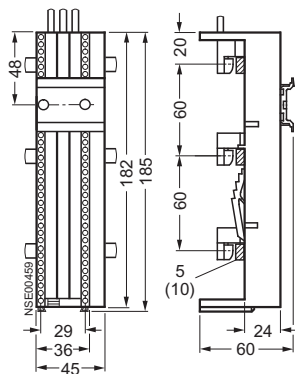

8US12 51-5DM07

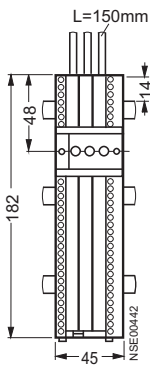

8US12 61-5FM08

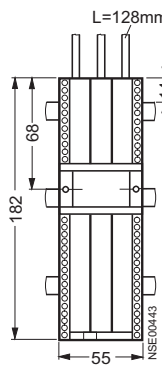

8US12 60-5AM00

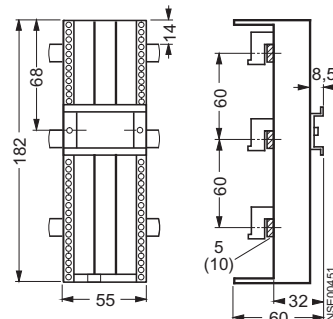

8US12 60-5AP00, 8US12 61-5FP08

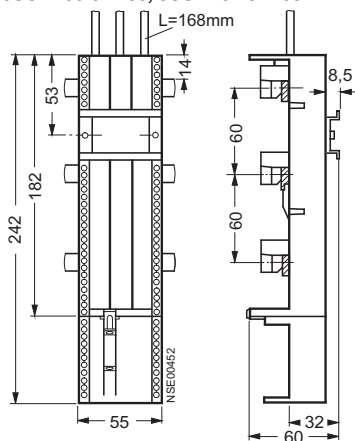

8US19 27-4AF00

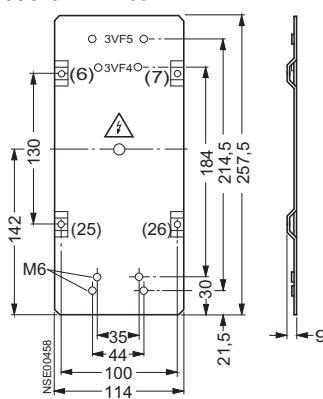

8US19 27-4AF01

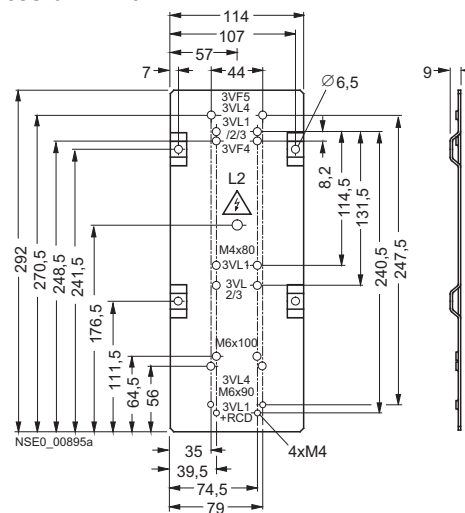

8US12 91-4SB00 with 3NP50

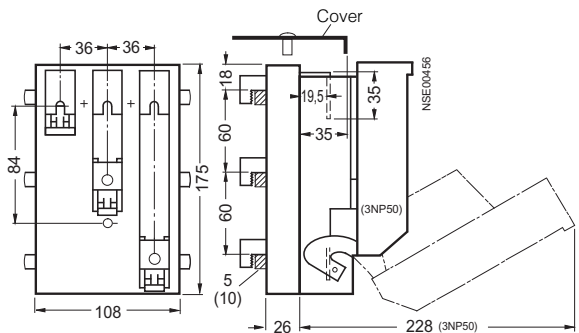

8US19 98-2BM00

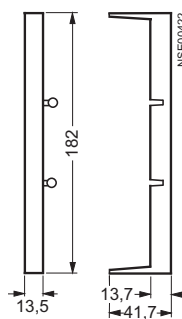

8US Busbar Systems

60 mm Busbar Systems

Bus-mounting fuse bases

Dimensional drawings

5SG6, 5SF6 bus-mounting fuse bases

5SG6 202 (t = 5 mm),
5SG6 203 (t = 10 mm)
 D02/63 A (a = 27 mm)
 (t = bar thickness)

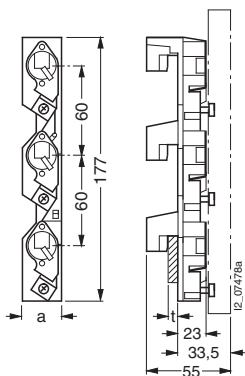

5SG6 204 (t = 5 mm),
5SG6 205 (t = 10 mm)
 D02/63 A (a = 42 mm)

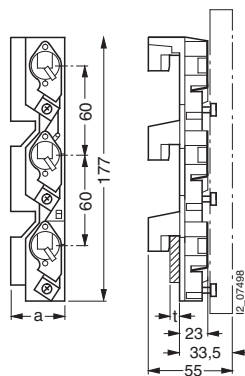

5SF6 014, 5SF6 015 (t = 5 mm),
5SF6 016, 5SF6 017 (t = 10 mm)
 DII/25 A (a = 57 mm)

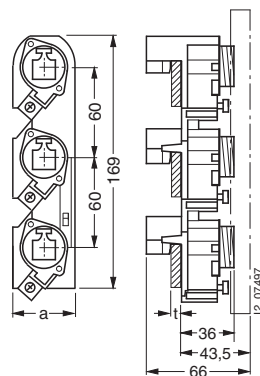

5SF6 214, 5SF6 215 (t = 5 mm),
5SF6 216, 5SF6 217 (t = 10 mm)
 DIII/63 A (a = 42 mm)

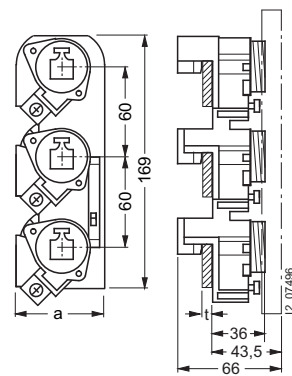

5SH covers for bus-mounting fuse base

5SH5 241
 single
 D02/63 A

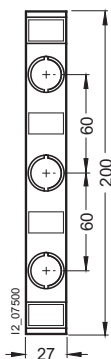

5SH5 242
 1.33-fold

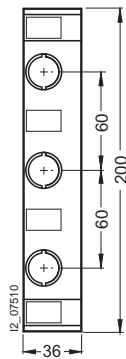

5SH5 243
 double

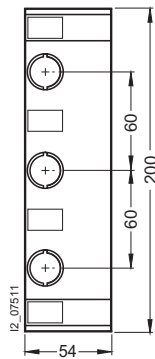

5SH2 042 (single: a = 42 mm)
5SH2 043 (double: b = 84 mm)
 DII/25 A

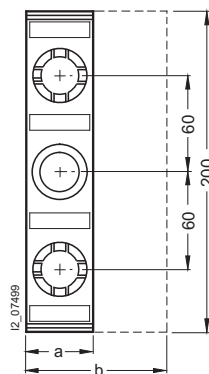

5SH2 242 (single: a = 57 mm)
5SH2 243 (double: b = 114 mm)
 DIII/63 A

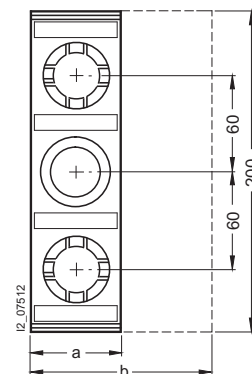

Dimensional drawings

8US19 21-2BE00

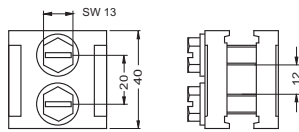

Max. tightening torque 15 Nm

8US19 21-2BF00

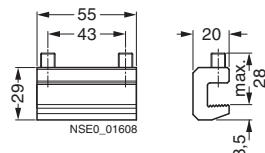

Max. tightening torque 12 Nm

8US19 41-2BF00

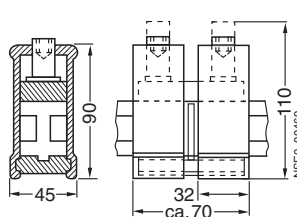

Max. tightening torque 30 Nm

8US19 98-1BA00

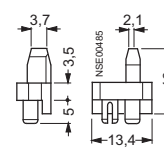

8US19 98-1CA00

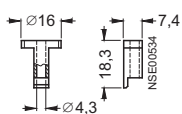

8US19 98-1DA00

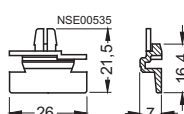

8US19 98-4AA00

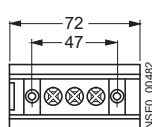

8US19 98-7CA08

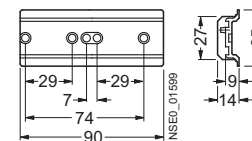

8US19 98-7CA10

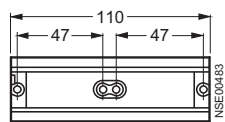

8US19 98-7CA15

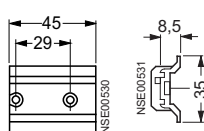

8US19 98-7CA16

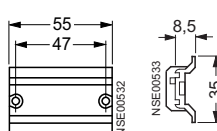

8US19 98-8AM07

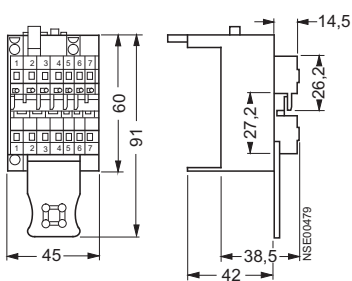

8US19 98-8AA10

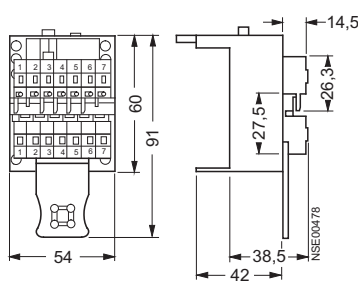

8US Busbar Systems

Notes

17



Software for Power Distribution



18/2

Introduction

Configuring, Visualizing and Controlling with SIMATIC

SIMATIC PCS 7 powerrate

SIMATIC WinCC powerrate

18/3

- Overview

18/3

- Function

18/4

- More information

Configuring, Visualizing and Controlling with SENTRON

Switch ES Power

18/5

- Overview

18/5

- Design

18/5

- Function

18/5

- Integration

Introduction

Overview

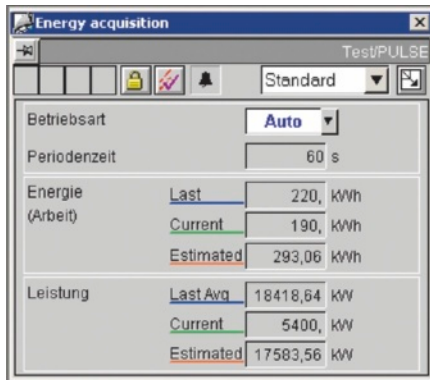

SIMATIC PCS 7 powerrate
SIMATIC WinCC powerrate

SIMATIC PCS 7 powerrate SIMATIC WinCC powerrate

SIMATIC PCS 7 and WinCC powerrate are add-ons to PCS 7 and WinCC respectively and throw light on power consumption from the infeed to the load.

- Identification of power-intensive consumer devices and processes in order to introduce measures for improving power efficiency
- Comparison of consumption profiles for greater efficiency of process design
- Optimizing the company according to energy parameters based on an assessment of consumption and costs
- Complying with the contractually agreed power limit, thus preventing higher power supply costs or penalty payments

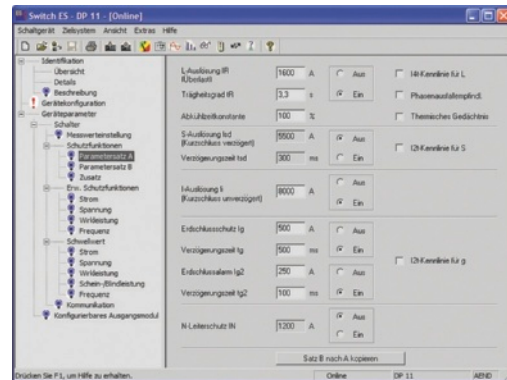

Switch ES Power

Switch ES Power

Shared software platform for communication-capable SENTRON 3WL and SENTRON 3VL circuit breakers:

- Parameterization, documentation, operation and monitoring in one software
- Clear representation of all available parameters
- All the available status information and measured values are displayed in dialog boxes
- Software for SENTRON 3WL and SENTRON 3VL

Planen, Parametrieren und Managen mit SIMARIS

Configuring, Visualizing and Controlling with SIMATIC

SIMATIC PCS 7 powerrate
SIMATIC WinCC powerrate

Overview

SIMATIC PCS 7 powerrate
SIMATIC WinCC powerrate



SIMATIC PCS 7 and WinCC powerrate are add-ons to PCS 7 and WinCC respectively and throw light on power consumption from the infeed to the load. Power data are continuously collected, archived and processed further. With an exact knowledge of the consumption profile it is possible to identify savings potential, optimize your power supply conditions and hence lower your power costs. Monitoring the contractually agreed power limit helps on the one hand to prevent unnecessarily high power prices or penalties and on the other hand to make full use of the fixed power limit.

Full integration in PCS 7 or WinCC enables the easy use of standard interfaces, e. g. to SIMATIC IT, or standard functionalities from PCS 7 or WinCC.

SIMATIC PCS 7 or WinCC powerrate is made up of the following components:

- Modules for the acquisition and processing of power data
- Faceplates for the presentation and processing of power data
- Excel macro for allocating power data to cost centers
- Components for implementing load management (calculating trends, monitoring limits, enabling/disabling loads)
- Faceplates for presenting results and for configuring load management
- Excel macro for determining the duration curve as a basis for load management decisions

Function

Power data acquisition and processing

Using prefabricated modules, power data can be collected from any Profibus-capable devices. The data can exist on the modules in the form of counting pulses, count values or power values. From these data the module calculates the power averages and the work values for a predefined period. Count values can also be entered manually. The results are archived in the PCS 7 Tag Logging Archive or in the WinCC Archive. In addition, a limit forecast is extrapolated for each period.

A sample function (heat calculation), which can be adapted through open interfaces at any time to the needs of the process, has been implemented in order to visualize customized calculations.

The data from manually read counters can be entered directly into the system and be used for further evaluations.

Presentation of the power data

Energy acquisition			
		Test/PULSE	
		Standard	
Betriebsart		Auto	
Periodenzeit		60 s	
Energie (Arbeit)	Last	220,	kWh
	Current	190,	kWh
	Estimated	293,06	kWh
Leistung	Last Avg	18418,64	kW
	Current	5400,	kW
	Estimated	17583,56	kW

The currently collected power data are presented as power averages / work values per time interval. A reserve curve presentation enables the evaluation of archived power data and their presentation in table form.

Planen, Parametrieren und Managen mit SIMARIS

Configuring, Visualizing and Controlling with SIMATIC

SIMATIC PCS 7 powerrate
SIMATIC WinCC powerrate

Further processing of data

The archived data can be exported directly from PCS 7 or WinCC to Excel. Using predefined macros it is possible to create various reports:

Cost center report

Here the consumption can be allocated to different cost centers and the costs calculated on the basis of predefined rates. The results can be output in 2 reports in table form or as a bar graph.

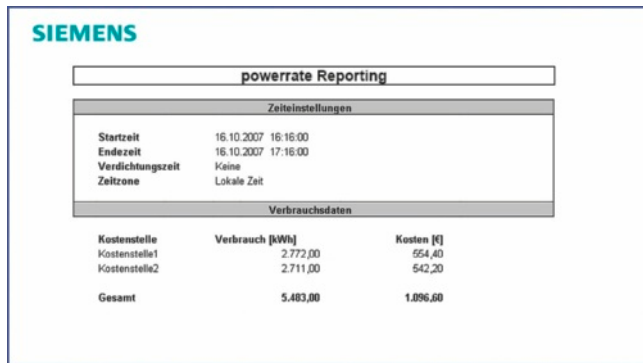

Report in table form

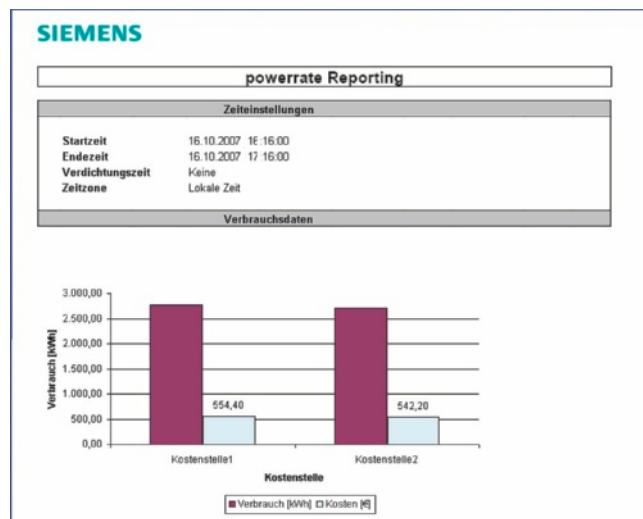

Report as a bar graph

Duration curve

An analysis is carried out on the basis of the archived power averages to establish how often a certain power average has occurred in a given period. From this curve it is quickly evident whether there are any short-time power peaks.

Customized further processing of the exported power data is possible in addition.

If the data are archived in the PCS 7 Tag Logging Archive or in the WinCC Archive, they can also be accessed with PCS 7 or WinCC tools.

Additional functions

To prevent the loss of data in the event of a communication fault, the data are temporarily stored in a cyclic buffer on the SIMATIC S7.

To ensure synchronicity with the power supply company, it is possible to evaluate the synchronization pulse from the power supply company.

Load management

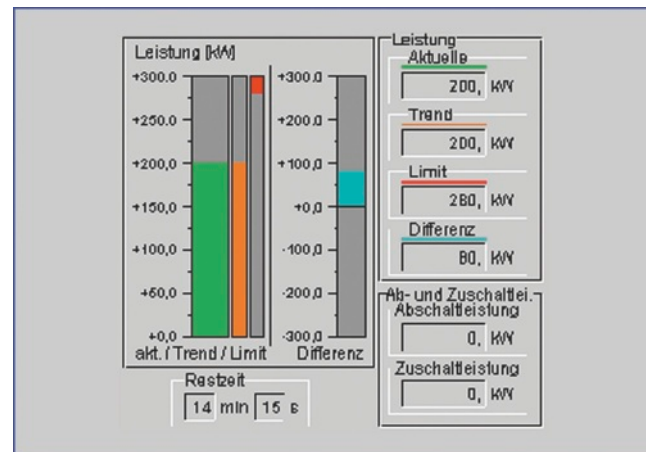

Contractually agreed power limits (for current it is typically the 15-minute power average) must be complied with; if not, there is a threat of far higher purchase prices or even penalty payments. The load management feature of SIMATIC PCS 7 and WinCC powerrate carries out cyclic trend calculations in order to issue warnings/alarm signals if violation of the limit is likely and to switch off loads in accordance with the given configuration should this be required. To prevent unnecessary switching operations there are many different parameters for adapting the load management to the current process conditions. All of which is done in simple and user-friendly manner through the faceplate.

For loads which are spread among different PLCs, SIMATIC PCS 7 and WinCC powerrate have suitable AS-AS communication modules so that they too can be integrated in the load management.

More information

More information is available on the Internet at:
<http://www.siemens.com/powermanagementsystem>

or from

Siemens AG
I IA CD MM1
Technical Assistance
Tel.: +49 (911) 895-59 00
Fax: +49 (911) 895-59 07
E-mail: technical-assistance@siemens.com

Planen, Parametrieren und Managen mit SIMARIS

Configuring, Visualizing and Controlling with SENTRON

Switch ES Power

Overview

Switch ES Power

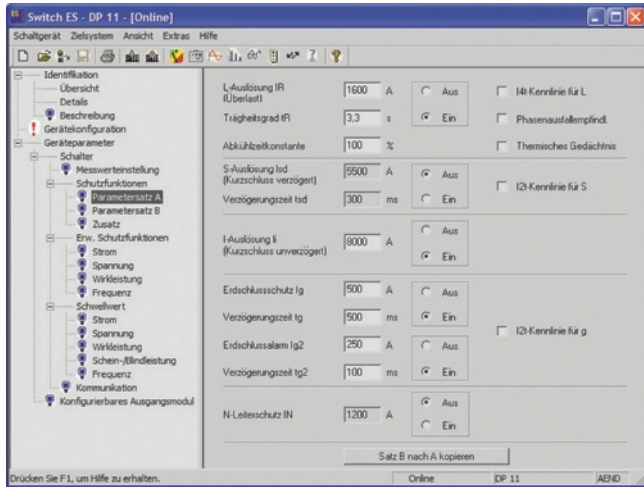

Adjustment of parameter set A with Switch ES Power

Switch ES Power is the shared software platform for communication-capable SENTRON circuit breakers. This has the advantage that all device-specific setting options are identical in terms of appearance and handling.

Switch ES Power can be used to configure, document, operate and monitor the SENTRON 3WL and SENTRON 3VL circuit breakers through PROFIBUS DP.

More information can be found on the Internet at: <http://www.siemens.com/sentron>

Design

The design of both the data tree and the individual data windows has been cross-referenced and harmonized with the structure of the Breaker Data Adapter. As a result, the same functions and information are available. Due to its support of the innovative PROFIBUS DPV1 function, it is particularly easy to link up a computer to the PROFIBUS using Switch ES Power. Simply connect, select the PROFIBUS address and start communication, even if the SENTRON circuit breakers are simultaneously exchanging data with another station (e. g. S7) via the PROFIBUS.

With Switch ES Power, it is also possible to create parameter sets offline without a direct connection to the circuit breaker. These parameter sets can then be transmitted to the SENTRON circuit breakers in the plant at a later stage.

Function

The Switch ES Power is used to load and display the control identification data. Depending on the circuit breaker configuration, the parameters for the protection function (LSING), the extended protection function, the configurable threshold values, the communication, and the configurable output module are displayed. These can be modified accordingly and loaded and stored on the switching device. Various online dialog boxes are available depending on the type of circuit breaker:

- Main view
- Diagnostics window
- Measured values window
- Window for displaying the harmonic analysis
- Window for displaying the curve form memory
- Dialog box for maintenance and statistics

The memory formats of the BDA and Switch ES Power are identical, which means that it is for example possible to generate central parameter files with Switch ES Power and then copy them to a notebook with the BDA for use by service personnel.

Switch ES Power supports all PROFIBUS cards for the Siemens PC/notebook. Some cards require an additional software package (driver); for more details refer to the interactive Catalog CA 01.

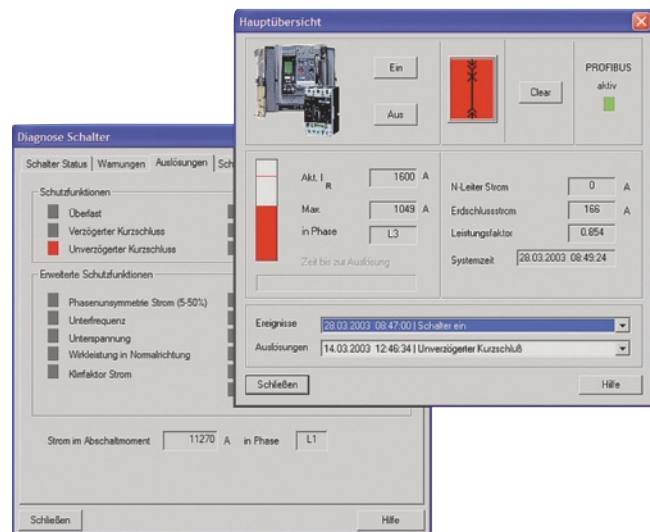

Online functions with Switch ES Power

Integration

Object manager of Switch ES Power

The Object Manager (OM) of Switch ES Power is used to integrate Switch ES Power into the STEP 7 environment, and therefore also into the Totally Integrated Automation (TIA) concept. This allows Switch ES Power to be called from the HWConfig Tool from STEP 7, and the SENTRON 3WL/3VL circuit breakers to be parameterized. This data is then stored in the STEP 7 database and automatically transferred to the circuit breaker via the PROFIBUS DP during every start-up (PLC, slave).



Planen, Parametrieren und Managen mit SIMARIS

Notes



BETA Low-Voltage Circuit Protection



You will find technical information about BETA low-voltage circuit protection in Catalog ET B1 (E86060-K8220-A101-B1-7600) or on the Internet at: <http://www.siemens.com/beta>

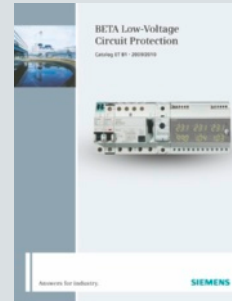

BETA Low-Voltage Circuit Protection

Notes



Appendix



20/2	Glossary
20/7	Training
20/8	Further documentation
20/9	Standards and approvals
20/10	Quality management
20/11	Siemens contacts
20/12	Solution partners
20/13	Online services
20/14	Customer Support
20/15	Software licenses
20/16	Subject index
20/22	Order number index
20/24	Terms and conditions of sale and delivery Export regulations

Glossary

Circuit breakers/motor starter protectors

Requirements to be met by circuit breakers for motor protection/motor starter protectors

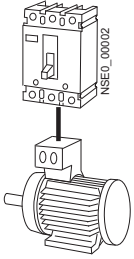

- Insensitivity to inrush current:
 - Response values of the short-circuit releases up to $13 \times I_n$ or
 - Inrush current bridging through tripping delay (approx. 10 ms to 20 ms)
- Temperature compensation
- Phase failure sensitivity

- Adjustable trip class for adapting to the motor start-up characteristic
- Thermal image memory (several start-up attempts raise the temperature of the motor)
- Overload release according to IEC 60947-4-1:
 - **Must not trip** at **1.05 times** load **within two** hours
 - **Must trip** at **1.2 times** load **within two** hours (at 1.15 times load for 2-phase load).

Circuit breakers for motor protection/motor starter protectors

Switching

- Operational currents of motors
- Short-circuit currents which arise in this load feeder

If circuit breakers/motor starter protectors with adjustable time lag class are used, they can be adapted to practically any motor starting current.

Circuit breakers/motor starter protectors for starter combinations

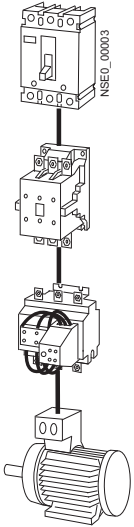

These circuit breakers/motor starter protectors are designed only for short-circuit protection of the downstream devices and loads; they have no overload releases. The short-circuit release is adjustable.

In this case the overload protection must be realized elsewhere. This can be a simple bimetal relay or a user-friendly electronic motor controller (SIMOCODE) between the load contactor and the load. As the result it is very easy in the event of a fault to distinguish between the overload relay (feedback of the bimetal relay) or the short-circuit release (feedback of the circuit breaker).

If a circuit breaker/motor starter protector with overload protection is selected, then a clear-cut assignment of the device feedback is not possible without additional steps.

The correct assignment of contactors, overload relay and circuit breaker/motor starter protector can be found in the publication "Load Feeders in Fuseless Designs", Order No. E20002-A580-P302-V2 or in the corresponding technical tables.

Non-automatic air circuit breakers

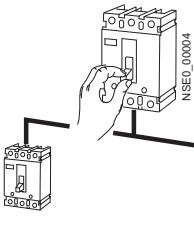

This form of circuit breaker is used wherever different load circuits have to be disconnected from or connected to each other. They are not equipped with overload releases. The short-circuit release is not adjustable.

Current-limiting circuit breakers

NSE0_01270

This symbol indicates the flow of the short-circuit current downstream from the circuit breaker. Because the let-through current of the circuit breaker is smaller than the maximum value of the short-circuit current (dotted line), the term "current-limiting circuit breaker" is used.

The load on the downstream devices, cables and conductors is greatly reduced as the result (in this connection see the current limiting characteristics).

Requirements to be met by circuit breakers for system protection

NSE0_00695

- Compliance with the standards IEC 60947-1 and IEC 60947-2:
 - **Must not trip at 1.05 times** load **within two** hours
 - **Must trip at 1.3 times** load **within two** hours
- Usual setting ranges:
 - Adjustability of the overload release is usually not required
 - Response values of the short-circuit releases 1.25 to 10 x I_n
- Analysis of selectivity required

Circuit breakers for system protection with permanently set values

They have a permanently set overload release and a permanently set short-circuit release.

Current limiting.

Example:

Outgoing feeder to sub-distribution boards/distribution boards.

Circuit breakers for system protection with some permanently set values

NSE0_00015

They have a permanently set overload release and an adjustable short-circuit release.

Current limiting.

Example:

Outgoing feeder to sub-distribution boards/distribution boards with special requirements to be met by the short-circuit release.

Circuit breakers for system protection with adjustable values

NSE0_00704

They have an adjustable overload release and an adjustable short-circuit release.

Current limiting.

Example:

For direct protection of non-motor loads.

Glossary

Circuit breakers/motor starter protectors

Circuit breakers for system protection with adjustable values and a short-time delayed release

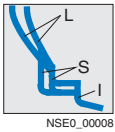

This means that:

- L: Inverse-time delayed overload release or thermal overload release.
 - If the actual current exceeds the value of the set operational current (I_r), then the circuit breaker will trip within a certain time.
 - The time of the tripping depends on the level of current.
 - The higher the level of current, the shorter the time up to tripping.
- S: Short-time delayed short-circuit release.
 - The level of the short-circuit current (I_{sd}) is variably adjustable.
 - The trip system (electromagnetic or solid-state) is excited by the short-circuit current which flows through the circuit breaker.
 - Tripping is delayed for the set time (t_{sd}).
 - Time-selective coordination of circuit breakers is thus possible.
- I: Instantaneous short-circuit release
 - The trip system (electromagnetic or solid-state) is excited by the short-circuit current which flows through the circuit breaker.
 - Tripping is instantaneous.

It makes sense for the value for the I trip unit (I_i) to be greater than the value for the S trip unit. If the time (t_{sd}) is selected as zero for the S trip unit, then the S trip unit responds like the I trip unit, i.e. tripping is likewise instantaneous.

Example: Fully selective circuit breaker in power distributions.

Circuit breakers for motor protection/motor starter protectors with permanently set time lag class



They have an adjustable overload release, a permanently set short-circuit release and a permanently set time lag class.

Current limiting.

Example:

For protecting motors with this start-up class.

Circuit breakers for motor protection/motor starter protectors with adjustable time lag class



They have an adjustable overload release, a permanently set short-circuit release and an adjustable time lag class.

Current limiting.

With phase failure sensitivity.

Example:

Protection of motors with different start-up classes (one standard circuit breaker/motor starter protector for all motors).

Circuit breakers/motor starter protectors for starter combinations

NSE0_00707

They have an adjustable short-circuit release but no overload release.

Current limiting.

Example:

Wherever a bimetal relay is connected downstream and a separate signal for short-circuit (from the starter circuit breaker) and overload (from the bimetal relay) is required.

Non-automatic air circuit breakers, current-limiting

NSE0_00708

MCCB:

They have a permanently set short-circuit release but no overload release (VL160X to VL1600).

Let-through current is limited.

Example:

For disconnecting different load circuits.

Non-automatic air circuit breakers

NSE0_00017

ACB:

They have neither an overcurrent release nor a short-circuit release (3WL).

Not current-limiting:

Example:

For disconnecting different load circuits.

Glossary

Semiconductor protection

Semiconductor safety fuse, semiconductor fuse

A semiconductor fuse is an extremely fast responding fuse for protecting semiconductor devices.

There are two versions of semiconductor fuses:

- **Partial-range fuses** provide optimum protection for the power semiconductor against the effects of short-circuit currents. Additional fuses or circuit breakers are required for protecting the device and the cable and leads in the overload range.
- **All-range fuses** protect the power semiconductor and the connected cables and lines against overload and short-circuit. Here a distinction is drawn between fuses with the smallest possible breaking I^2t value (gR) and fuses with the smallest possible power loss and a characteristic adapted exactly to the line protection (double protection fuses gS).

Function class

The function class defines the breaking characteristic of the fuses:

- **Function class a**

Partial-range fuses:

Fuse links, that carry currents at least up to their rated current and can interrupt currents above a specific multiple of their rated current (minimum breaking current) up to their rated breaking capacity. The range between the rated current of the fuse link and the minimum breaking current is a forbidden range.

- **Function class g**

All-range fuses:

Fuse links that can continuously carry currents up to at least their rated current and can interrupt currents from the smallest melting current through to the rated breaking capacity.

Operational class

The operational class is the designation of the function class of a fuse link in connection with the object to be protected.

- **Operational class gS**
Full range semiconductor protection – preferably for use in safety switching devices
- **Operational class gR**
Full-range semiconductor protection
- **Operational class aR**
Partial-range semiconductor protection

Faster and more applicable know-how: Hands-on training from the manufacturer

SITRAIN® – the Siemens Training for Automation and Industrial Solutions – provides you with comprehensive support in solving your tasks.

Training by the market leader in automation and plant engineering enables you to make independent decisions with confidence. Especially where the optimum and efficient use of products and plants are concerned. You can eliminate deficiencies in existing plants, and exclude expensive faulty planning right from the beginning.



First-class know-how directly pays for itself: In shorter startup times, high-quality end products, faster troubleshooting and reduced downtimes. In other words, increased profits and lower costs.

Achieve more with SITRAIN

- Shorter times for startup, maintenance and servicing
- Optimized production operations
- Reliable configuration and startup
- Minimization of plant downtimes
- Flexible plant adaptation to market requirements
- Compliance with quality standards in production
- Increased employee satisfaction and motivation
- Shorter familiarization times following changes in technology and staff

Contact

Visit our site on the Internet at:

www.siemens.com/sitrain

or let us advise you personally. You can request our latest training catalog from:

SITRAIN Customer Support Germany:

Phone: +49 (0)1805 / 23 56 11

Fax: +49 (0)1805 / 23 56 12

(0.14 €/min. from a German landline network, mobile telephone prices may vary)

E-Mail: info@sitrain.com

SITRAIN highlights

Top trainers

Our trainers are skilled teachers with direct practical experience. Course developers have close contact with product development, and directly pass on their knowledge to the trainers.

Practical experience

The practical experience of our trainers enables them to teach theory effectively. But since theory can be pretty drab, we attach great importance to practical exercises which can comprise up to half of the course time. You can therefore immediately implement your new knowledge in practice. We train you on state-of-the-art methodically/didactically designed training equipment. This training approach will give you all the confidence you need.

Wide variety

With a total of about 300 local attendance courses, we train the complete range of Siemens products as well as interaction of the products in systems. Telecourses, teach-yourself software and seminars with a presenter on the Web supplement our classic range of courses.

Tailor-made training

We are only a short distance away. You can find us at more than 50 locations in Germany, and in 62 countries worldwide. You wish to have individual training instead of one of our 300 courses? Our solution: We will provide a program tailored exactly to your personal requirements. Training can be carried out in our Training Centers or at your company.

The right mixture: Blended learning

"Blended learning" means a combination of various training media and sequences. For example, a local attendance course in a Training Center can be optimally supplemented by a teach-yourself program as preparation or follow-up. Additional effect: Reduced traveling costs and periods of absence.



Appendix

Further documentation

Overview

You will find all the latest information material, such as brochures, catalogs, manuals and operating instructions on low-voltage controls and distribution on the Internet at:

<http://www.siemens.com/lowvoltage/info>

Here you can order your copy of the available documentation or download it in common file formats (PDF, ZIP).

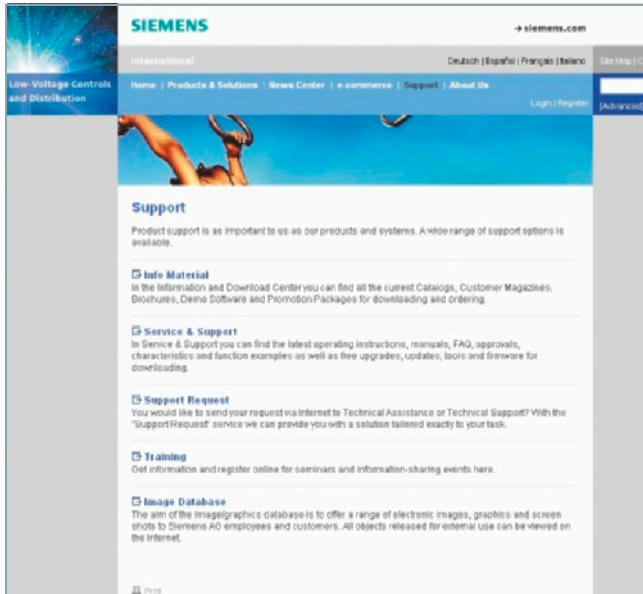

We also provide further support for SIRIUS - SENTRON - SIVACON

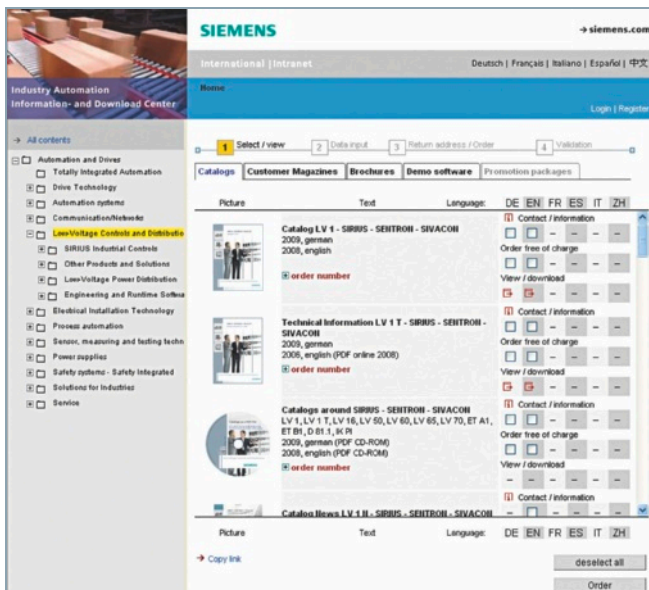

Brochures, catalogs and CDs offer fast and more in-depth information

We regard product support as just as important as the products and systems themselves. Visit our Support site on the Internet for a comprehensive range of material on SIRIUS, SENTRON and SIVACON, such as

- Catalogs available to order free of charge
 - Operating instructions and manuals for direct download
 - Online registration for seminars and events
 - Up-to-date answers to your queries and problems
 - Software upgrades and updates for fast download
 - Telephone assistance in more than 190 countries
 - Photos and graphics for external use
- and much, much more - all conveniently and easily accessible.

For your inventory control and planning systems we can provide commercial, technical and graphic data in electronic form for the range of low-voltage control products:

Technical Product Data for CAx Applications

Edition 07/2008

The DVD provides the product range of low-voltage controls and distribution for further processing in CAE/CAD systems.

- Technical product data in CSV and Excel format
- Graphical product data
 - 2D dimensional graphics and isometric graphics in DXF and DWG format
 - 3D models in STEP format
- Product data sheets as pdf data in
 - English
 - French
 - German
 - Spanish
- Tender texts in GAEB and text formats

Order No.: E86060-D1000-A207-A5-6300

Token fee 10.-- €

Overview

Approvals, test certificates, characteristic curves

An overview of the certificates available for low-voltage controls and distribution products along with more technical documentation can be consulted daily on the Internet at:

<http://www.siemens.com/lowvoltage/support>

The screenshot shows the Siemens website interface for 'Low-Voltage Controls and Distribution'. The left sidebar contains a navigation menu with categories like 'Product Information', 'Drive Technology', 'Automation systems', 'Communication/Networks', 'Low-Voltage Controls and Distribution', 'Components', 'Engineering and Runtime Software', 'Electrical Installation Technology', 'Process automation', 'Sensors, measuring and testing tech', 'Power supplies', 'Safety systems - Safety Integrated', 'Industries', and 'Service'. The main content area is titled 'Low-Voltage Controls and Distribution' and features a search filter section with the following settings:

- Entry type: Certificates
- Certificate Type: all
- Certificate: all
- Approval office: all
- Country: all

The search results are displayed in a table with columns for 'Title' and 'Date':

Title	Date
Certificates General Product Approval, KETI, KETI KETI, South Korea, HM05014-7011A for products: 3RV1321	2008-10-08 ID: 31906867
Certificates General Product Approval, KETI, KETI KETI, South Korea, HM05014-7012A for products: 3RV1321, 3RV1331	2008-10-08 ID: 31907076
Certificates General Product Approval, KETI, KETI KETI, South Korea, HM05014-7013A for products: 3RV1331	2008-10-08 ID: 31906875
Certificates General Product Approval, KETI, KETI KETI, South Korea, HM05014-7014A for products: 3RV1341	2008-10-08 ID: 31907822
Certificates General Product Approval, KETI, KETI KETI, South Korea, HM05014-7015A for products: 3RV1342	2008-10-08 ID: 31906963
Certificates General Product Approval, KETI, KETI KETI, South Korea, HM05014-7017A for products: 3RV1342	2008-10-08 ID: 31907209

Product support: Approvals / Certificates

The screenshot shows the Siemens website interface for 'Low-Voltage Controls and Distribution'. The left sidebar is identical to the previous screenshot. The main content area is titled 'Low-Voltage Controls and Distribution' and features a search filter section with the following settings:

- Entry type: Characteristics

The search results are displayed in a table with columns for 'Title' and 'Date':

Title	Date
Characteristics Tripping Characteristics, NEP560097002000D502 [934 KB], english Overload tripping class 20E 0,1 - 0,4 A for products: 3RA6120-0AE30; 3RA6120-0AE30; 3RA6120-0AP30; more>>	2008-05-06 ID: 29216949
Characteristics Tripping Characteristics, NEP_560096502000D502 [938 KB], english Overload tripping Sirius class 10E 0,1 - 0,4 A for products: 3RA6120-0AE30; 3RA6120-0AE30; 3RA6120-0AP30; more>>	2008-05-06 ID: 29216113
Characteristics Tripping Characteristics, NEP5600971000D501 [933 KB], english Overload tripping class 20E 0,32 - 1,25 A for products: 3RA6120-0BE30; 3RA6120-0BE30; 3RA6120-0BP30; more>>	2008-05-06 ID: 29216900
Characteristics Tripping Characteristics, NEP560096602000D502 [930 KB], english Overload tripping Sirius class 10E 0,32 - 1,25 A for products: 3RA6120-0BE30; 3RA6120-0BE30; 3RA6120-0BP30; more>>	2008-05-06 ID: 29216775
Characteristics Tripping Characteristics, NEP560096702000D502 [931 KB], english Overload tripping Sirius class 10 E 1 - 4 A for products: 3RA6120-0CE30; 3RA6120-0CE30; 3RA6120-0CP30; more>>	2008-05-06 ID: 29216776
Characteristics Tripping Characteristics, NEP5600972000D501 [963 KB],	2008-09-17

Product support: Characteristic curves

Quality management

Quality management

The quality management system of our A&D division complies with the international standard EN ISO 9001.

The products and systems described in this catalog are sold under application of a quality management system certified by DQS and TÜV Management Service GmbH in according to the ISO 9001. The certificates are recognized in all IQ Net countries.

DQS Registered Certificate Nos.:

Siemens AG
Automation and Drives

- Industrial Automation Systems
Reg. No.: 001323 QM
- Sensors and Communication
Industrial Communication
Reg. No.: 000656 QM.

TÜV (German Technical Inspectorate) Registered Certificate No.:

Siemens AG
Automation and Drives

- Low-Voltage Controls
Reg. No.: 12 100 16950 TMS.

BVQI Registered Certificate No.:

Siemens AG
Automation and Drives

- Electrical Installation Technology
Reg. No.: 117779

Certificates

An overview of the certificates available for SIMATIC NET products (CE, UL, CSA, FM, shipping authorizations) can be found on the Internet at:

<http://www.siemens.com/simatic-net>

Other certificates for SIMATIC products can be found on the Internet at:

<http://www.siemens.com/simatic>

These lists are continuously revised and updated. Data for products not yet included in the overview are continuously collected and prepared for subsequent editions.

You can find certificates, approvals, verification test certificates and characteristic curves at:

Support\Certificates

Title	Date
Certificates General Product Approval, UL, UL UL-Approval USA of "Programmable Controllers": Mobile Panels 170, 177 and 277 (English), Certificate NRAG.E118536 for products: 6AV5645-4B... 6AV5645-BA... 6AV5645-6B... 6AV more>>	2008-10-30 ID: 1928923
Certificates General Product Approval, UL, UL UL-Approval Canada of "Programmable Controllers": Mobile Panels 170, 177 and 277 (English), Certificate NRAG.E118536 for products: 6AV5645-4B... 6AV5645-BA... 6AV5645-6B... 6AV more>>	2008-10-30 ID: 2394871
Certificates General Product Approval, UL, UL UL-Approval for USA of "Programmable Controller": S7-300, C7, ET 200, HM, LOGO, SS Components (English), Certificate NRAG.E118536	2008-10-30 ID: 1899640
Certificates General Product Approval, UL, UL UL-Approval for Canada of S7-300, C7, ET 200, HM, LOGO, SS, Net Components (english), Certificate NRAG.E118536	2008-10-30 ID: 1899660

or by going directly to the Link Box:

- All about
- Communication/Networks
- Pre sales info
- Catalog & ordering system online
- Technical Info
- Support
- Product support
- FAQs
- Software downloads
- Manuals / Operating instructions
- Approvals / Certificates
- Updates
- Newsletter
- Forum
- Training
- Contact & Partners

Siemens contacts worldwide

At

<http://www.siemens.com/automation/partner>

you can find details of Siemens contact partners worldwide responsible for particular technologies.

You can obtain in most cases a contact partner for

- Technical Support,
- Spare parts/repairs,
- Service,
- Training,
- Sales or
- Consultation/engineering.

You start by selecting a

- Country,
- Product or
- Sector.

By further specifying the remaining criteria you will find exactly the right contact partner with his/her respective expertise.

Appendix

Siemens Solution Partners Automation, Power Distribution and PLM

Overview

Solution Partner Automation	SIEMENS
Solution Partner Power Distribution	SIEMENS
Solution Partner PLM	SIEMENS

Using the "Siemens Solution Partner" name, selected system integrators act as solution providers, qualified to a uniform global standard, for the Siemens range of products and services in the fields of automation, power distribution and product lifecycle management (PLM).

In the Siemens Solution Partner Program, our strengths merge with the expertise of our Solution Partners. Our product and system know-how works together with the comprehensive application and industry know-how of our partners to create solutions which are always the perfect answer to every requirement.

The number of Solution Partners has increased dynamically to more than 850 certified partners who are involved in implementing future-proof and tailor-made solutions in more than 45 countries.

The Solution Partner Finder is an Internet database in which all our Solution Partners are listed with their performance profiles.

Search criteria include technology, industry, country as well as company and zip code. From here it is a small step to making first contacts.

You can call up the Solution Partner Finder as follows:

- CA 01 on DVD:
On the opening page via "Contact & Partners; Siemens Solution Partner Automation, Power Distribution and PLM"
- CA 01 online:
Direct to the Solution Partner Finder:
<http://www.siemens.com/automation/partnerfinder>

Further information on the Siemens Solution Partner Program is available on the Internet at:

<http://www.siemens.com/automation/solutionpartner>

Siemens Industry Automation and Drive Technologies in the WWW



A detailed knowledge of the range of products and services available is essential when planning and configuring automation systems. It goes without saying that this information must always be fully up-to-date.

Siemens Industry Automation and Drive Technologies has therefore built up a comprehensive range of information in the World Wide Web, which offers quick and easy access to all data required.

Under the address

<http://www.siemens.com/automation>

you will find everything you need to know about products, systems and services.

Product Selection Using the Offline Mall

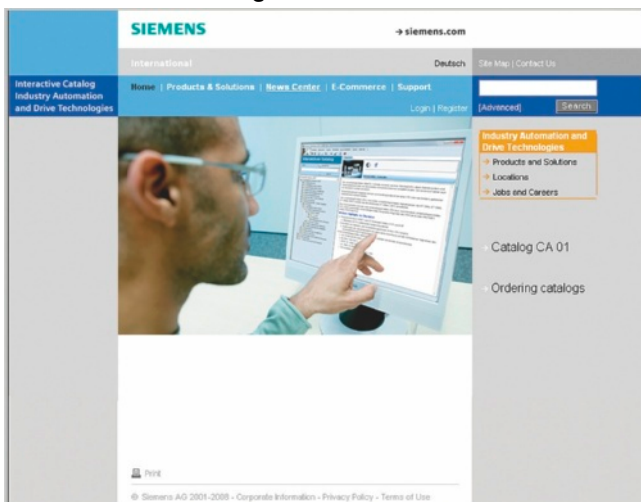

Detailed information together with convenient interactive functions:

The Offline Mall CA 01 covers more than 80,000 products and thus provides a full summary of the Siemens Industry Automation and Drive Technologies product base.

Here you will find everything that you need to solve tasks in the fields of automation, switchgear, installation and drives. All information is linked into a user interface which is easy to work with and intuitive.

After selecting the product of your choice you can order at the press of a button, by fax or by online link.

Information on the Offline Mall CA 01 can be found in the Internet under

<http://www.siemens.com/automation/ca01>

or on DVD.

Easy Shopping with the A&D Mall

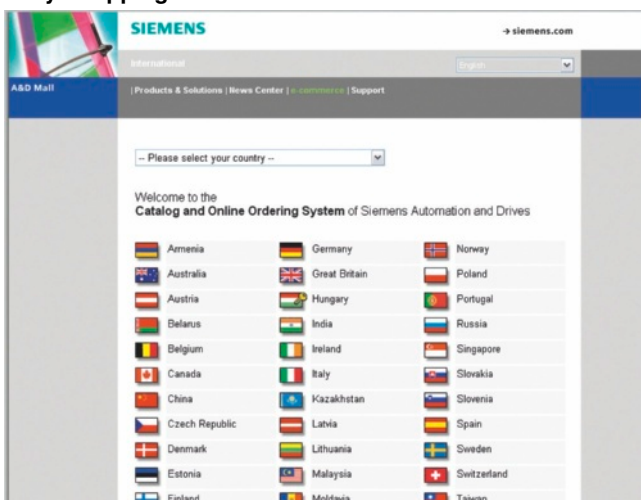

The A&D Mall is the virtual department store of Siemens AG in the Internet. Here you have access to a huge range of products presented in electronic catalogs in an informative and attractive way.

Data transfer via EDIFACT allows the whole procedure from selection through ordering to tracking of the order to be carried out online via the Internet.

Numerous functions are available to support you.

For example, powerful search functions make it easy to find the required products, which can be immediately checked for availability. Customer-specific discounts and preparation of quotes can be carried out online as well as order tracking and tracing.

Please visit the A&D Mall on the Internet under:

<http://www.siemens.com/automation/mall>

Appendix

Customer Support



In the face of harsh competition you need optimum conditions to keep ahead all the time:

A strong starting position. A sophisticated strategy and team for the necessary support - in every phase.

Service & Support from Siemens provides this support with a complete range of different services for automation and drives.

In every phase: from planning and startup to maintenance and upgrading.

Our specialists know when and where to act to keep the productivity and cost-effectiveness of your system running in top form.

Configuration and software engineering

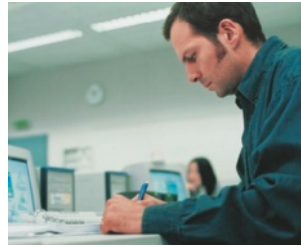

Support in configuring and developing with customer-oriented services from actual configuration to implementation of the automation project.²⁾

Technical Support



Competent consulting in technical questions covering a wide range of customer-oriented services for all our products and systems.

Tel.: +49 (0)180 50 50 222
Fax: +49 (0)180 50 50 223
 (0.14 €/min from the German fixed network)

<http://www.siemens.com/automation/support-request>

Online Support



The comprehensive information system available round the clock via Internet ranging from Product Support and Service & Support services to Support Tools in the Shop.

<http://www.siemens.com/automation/service&support>

Service on Site



With Service On Site we offer services for startup and maintenance, essential for ensuring system availability.

In Germany
0180 50 50 444²⁾
 (0.14 €/min from the German fixed network)

Technical Consulting



Support in the planning and designing of your project from detailed actual-state analysis, target definition and consulting on product and system questions right to the creation of the automation solution.²⁾

Repairs and Spare Parts



In the operating phase of a machine or automation system we provide a comprehensive repair and spare parts service ensuring the highest degree of operating safety and reliability.

In Germany
0180 50 50 446¹⁾
 (0.14 €/min from the German fixed network)

Technical Assistance

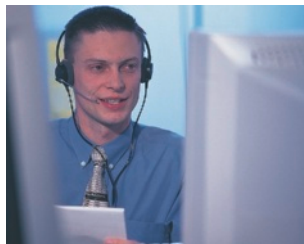

Expert technical assistance¹⁾ for Low-voltage controls and electrical installation.

Tel.: +49 (9 11) 8 95-59 00
Fax: +49 (9 11) 8 95-59 07

E-Mail: technical-assistance@siemens.com

Optimization and Upgrading



To enhance productivity and save costs in your project we offer high-quality services in optimization and upgrading.²⁾

¹⁾ Contact:
[Technical assistance](#) for product selection · Old/new coding · Competitor coding · Special versions · Special requirements · Sales promotion (Infoline).
[Your regional contacts](#) for sales support (prices, discounts, delivery times).
[Technical Support](#) for commissioning support and after-sales services.

²⁾ For country-specific telephone numbers go to our Internet site at:
<http://www.siemens.com/automation/service&support>

Übersicht

Software types

Software requiring a license is categorized into types. The following software types have been defined:

- Engineering software
- Runtime software

Engineering software

This includes all software products for creating (engineering) user software, e.g. for configuring, programming, parameterizing, testing, commissioning or servicing.

Data generated with engineering software and executable programs can be duplicated for your own use or for use by third-parties free-of-charge.

Runtime software

This includes all software products required for plant/machine operation, e.g. operating system, basic system, system expansions, drivers, etc.

The duplication of the runtime software and executable programs created with the runtime software for your own use or for use by third-parties is subject to a charge.

You can find information about license fees according to use in the ordering data (e.g. in the catalog). Examples of categories of use include per CPU, per installation, per channel, per instance, per axis, per control loop, per variable, etc.

Information about extended rights of use for parameterization/configuration tools supplied as integral components of the scope of delivery can be found in the readme file supplied with the relevant product(s).

License types

Siemens Automation & Drives offers various types of software license:

- Floating license
- Single license
- Rental license
- Trial license
- Factory license

Floating license

The software may be installed for internal use on any number of devices by the licensee. Only the concurrent user is licensed. The concurrent user is the person using the program. Use begins when the software is started.

A license is required for each concurrent user.

Single license

Unlike the floating license, a single license permits only one installation of the software.

The type of use licensed is specified in the ordering data and in the Certificate of License (CoL). Types of use include for example per device, per axis, per channel, etc.

One single license is required for each type of use defined.

Rental license

A rental license supports the "sporadic use" of engineering software. Once the license key has been installed, the software can be used for a specific number of hours (the operating hours do not have to be consecutive).

One license is required for each installation of the software.

Trial license

A trial license supports "short-term use" of the software in a non-productive context, e.g. for testing and evaluation purposes. It can be transferred to another license.

Factory license

With the Factory License the user has the right to install and use the software at one permanent establishment only. The permanent establishment is defined by one address only. The number of hardware devices on which the software may be installed results from the order data or the Certificate of License (CoL).

Certificate of license

The Certificate of License (CoL) is the licensee's proof that the use of the software has been licensed by Siemens. A CoL is required for every type of use and must be kept in a safe place.

Downgrading

The licensee is permitted to use the software or an earlier version/release of the software, provided that the licensee owns such a version/release and its use is technically feasible.

Delivery versions

Software is constantly being updated.

The following delivery versions

- PowerPack
- Upgrade

can be used to access updates.

Existing bug fixes are supplied with the ServicePack version.

PowerPack

PowerPacks can be used to upgrade to more powerful software. The licensee receives a new license agreement and CoL (Certificate of License) with the PowerPack. This CoL, together with the CoL for the original product, proves that the new software is licensed.

A separate PowerPack must be purchased for each original license of the software to be replaced.

Upgrade

An upgrade permits the use of a new version of the software on the condition that a license for a previous version of the product is already held.

The licensee receives a new license agreement and CoL with the upgrade. This CoL, together with the CoL for the previous product, proves that the new version is licensed.

A separate upgrade must be purchased for each original license of the software to be upgraded.

ServicePack

ServicePacks are used to debug existing products.

ServicePacks may be duplicated for use as prescribed according to the number of existing original licenses.

License key

Siemens Automation & Drives supplies software products with and without license keys.

The license key serves as an electronic license stamp and is also the "switch" for activating the software (floating license, rental license, etc.).

The complete installation of software products requiring license keys includes the program to be licensed (the software) and the license key (which represents the license).



Detailed explanations concerning license conditions can be found in the "Terms and Conditions of Siemens AG" or under <http://www.siemens.com/automation/mall> (A&D Mall Online-Help System)

A&D/Software licenses/En 03.08.06

Subject index

	Page		Page		Page
Numerics		3RV1 motor starter protectors (cont.)		AS-Interface	
3NJ6 in-line design for S8	14/4	Limiter function	5/13	ASIsafe	2/11 ... 2/21
3RA1 fuseless load feeders	6/63 ... 6/87	Link modules	5/2	Communication overview	2/10
3RA6 compact feeders	6/88 ... 6/109	Main and EMERGENCY-STOP switches	5/9	Compact starters, 400 V AC	6/142 ... 6/147
3RB2 solid-state overload relays	5/70 ... 5/94	Motor protection	5/2, 5/8	Configuration examples	2/9
for High-Feature applications	5/80 ... 5/93	Mounting accessories	5/5, 5/26 ... 5/29, 5/32	Load feeder modules	6/76 ... 6/78
for standard applications	5/70 ... 5/79	Operating mechanisms	5/8	Masters	2/22 ... 2/25
Terminal brackets	5/94	Permissible rated data of approved devices		Motor starters, 24 V DC	6/159 ... 6/162
3RK3 modular safety system	7/147 ... 7/154	- for North America (UL/CSA)	5/16 ... 5/19	Power supply units	2/93 ... 2/95
3RN1 thermistor motor protection		Remote motorized operating mechanisms	5/2, 5/30, 5/31, 5/37	Routers	2/26 ... 2/33
Explosion protection (ATEX)	7/5	Rotary operating mechanisms	5/2, 5/30, 5/36	Signaling columns	9/34
for PTC sensors	7/110 ... 7/115	Schematics	5/25	Slaves	2/34 ... 2/92
3RP15 timing relays in industrial enclosures	7/41 ... 7/51	Short-circuit breaking capacity	5/11, 5/12	System components and accessories	
3RP20 timing relays, 45 mm	7/41 ... 7/43, 7/52 ... 7/54	Short-circuit protection	5/8	- Accessories	2/104 ... 2/105
3RS10, 3RS11 temperature monitoring relays	7/97 ... 7/109	Shunt trip units	5/2, 5/26 ... 5/29	- Addressing units	2/102
3RS17 interface converters	7/155 ... 7/158	Signal switches	5/2, 5/20, 5/26 ... 5/29	- Analyzers	2/103
3RT19 16, 3RT19 26 timing relays for mounting onto contactors	7/44, 7/55 ... 7/58	Solder pin connections	5/32, 5/37	- Extension plugs	2/99 ... 2/101
3RT19 schematic	3/230	Starter combinations	5/2	Transmission Media	
3RU1 thermal overload relays	5/59 ... 5/69	System protection	5/2, 5/9	- Shaped cables	2/96
for standard applications	5/59 ... 5/69	Terminals	5/32, 5/37	ASIsafe	
Terminal brackets	5/69	Transformer protection	5/2, 5/9	Position switches	8/56 ... 8/62
3RV1 molded case motor starter protectors	5/1, 5/3, 5/40 ... 5/54	Trip classes	5/8, 5/42	Safety modules	2/16 ... 2/21
Auxiliary switches	5/3, 5/49	Trip units	5/8	Safety monitors	2/15
Auxiliary trip units	5/49	Undervoltage trip units	5/2, 5/26 ... 5/29	ATEX	
Characteristic curves	5/46	Voltage transformer motor starter protectors	5/2, 5/7, 5/10, 5/20, 5/25	3RN1 thermistor motor protection	7/5
Installation guidelines	5/41	3TK28 safety relays	7/116 ... 7/146	3RV1 motor starter protectors	5/6, 5/14
Motor protection	5/3, 5/43	with contactor relay enabling circuits	7/116, 7/117, 7/138 ... 7/142	Overload relay	5/59, 5/61, 5/72, 5/81, 5/84
Mounting accessories	5/49	with electronic enabling circuits	7/116 ... 7/126	Position switches	8/3
Rotary operating mechanisms	5/3, 5/50, 5/52, 5/54	with relay enabling circuits	7/116, 7/117, 7/127 ... 7/137	SIMOCODE pro 3UF7 motor management and control devices	7/5
Short-circuit protection	5/43	with special functions	7/116, 7/117, 7/143 ... 7/146	Autotransformers	10/2 ... 10/16, 10/22, 10/23, 10/25, 10/31 ... 10/41, 10/44, 10/45
Shunt trip units	5/3, 5/49	3UF18 current transformers for overload protection	7/32 ... 7/36	for matching purposes	10/3, 10/42
Starter combinations	5/3	3UL22 summation current transformer	7/83	Auxiliary switch blocks	
Terminals	5/45, 5/50, 5/51, 5/53	8US busbar systems	17/72 ... 17/91	for contactors and contactor relays	
Trip classes	5/42	40 mm		- Laterally mountable	3/197, 3/223, 3/227, 3/230, 3/239
Trip units	5/42	- Accessories	17/79	- Snap-on	3/176, 3/177, 3/196, 3/197, 3/222, 3/223, 3/228, 3/229
Undervoltage trip units	5/3, 5/49	- Base assemblies	17/74	- Solid-state compatible	3/196, 3/222, 3/228
3RV1 motor starter protectors	5/1, 5/2, 5/5 ... 5/39	- Busbar adapters	17/76 ... 17/78	- Solid-state time-delay	3/170, 3/193, 3/222, 3/223, 3/229, 3/230
Accessories	5/2, 5/5	- Connection methods	17/75	Auxiliary switches	17/46
Auxiliary switches	5/2, 5/20, 5/26 ... 5/28	- Device holders	17/76 ... 17/78	for 3KA/3KE	17/7, 17/9
Auxiliary trip units	5/26 ... 5/29	- Infeeds	17/75	for 3KL	17/25
Busbar adapters	5/2	60 mm		for 3KM	17/30
Busbar systems	5/2, 5/33 ... 5/35	- Accessories	17/91	for 3LD	17/14
Characteristic curves	5/21	- Base assemblies	17/81 ... 17/84	for 3NJ62	17/46
Distance protection	5/2, 5/7, 5/20	- Busbar adapters	17/87 ... 17/89	for 3NP	17/57
Door-coupling rotary operating mechanisms	5/2, 5/30, 5/36	- Bus-mounting fuse bases	17/90	for 3RV1 molded case motor starter protectors	5/3, 5/49
Enclosures	5/2, 5/38, 5/39	- Connection methods	17/85, 17/86	for 3RV1 motor starter protectors	5/2, 5/20, 5/26 ... 5/28
- for flush mounting	5/2, 5/39	- Device holders	17/87 ... 17/89	Auxiliary terminals	3/196
- for surface mounting	5/2, 5/38, 5/39	- Infeeds	17/85, 17/86	Auxiliary trip units	
Explosion protection (ATEX)	5/6, 5/14	A		for 3RV1 molded case motor starter protectors	5/49
Feeder terminals	5/35	Accessories and spare parts		for 3RV1 motor starter protectors	5/26 ... 5/29
Front plates	5/2, 5/39	3RV1 motor starter protectors	5/2, 5/5	for circuit breakers	16/12, 16/21
Fuse monitoring	5/2, 5/9	for contactors and contactor relays		B	
Infeed systems	5/2	3/167 ... 3/177, 3/192 ... 3/199, 3/207, 3/209, 3/211, 3/213 ... 3/215, 3/221 ... 3/230, 3/239 ... 3/241, 3/243, 3/245, 3/246		Base plate for contactor assemblies	3/199
Installation guidelines	5/7, 5/8	Addressing units	2/102	Baud rate for PAC3200	13/9, 13/16, 13/17
Insulated three-phase busbar system	5/2, 5/33 ... 5/35	Air circuit breakers	15/1 ... 15/56	Bi-metal measuring devices	17/48
Isolator modules	5/2, 5/26, 5/33	Ambient conditions for PAC3200	13/11, 13/16, 13/17	Busbar adapter systems	16/72
IT systems	5/9	Analzers	2/103	Busbar adapters for 3RV1 motor starter protectors	5/2
				Busbar systems for 3RV1 motor starter protectors	5/2, 5/33 ... 5/35

	Page		Page		Page
C					
Cable-operated switches	9/3, 9/26 ... 9/29	Contactors		D	
Capacitive switching capacity for 3NJ4/3NJ5	17/68	for special applications	3/93 ... 3/129, 3/181, 3/183, 3/184, 3/186 ... 3/190, 3/208 ... 3/212, 3/214, 3/225, 3/228, 3/230, 3/241 ... 3/245	DC current	
Capacitor contactors	3/118, 3/119, 3/187, 3/225, 3/230	- Capacitor contactors	3/118, 3/119, 3/187, 3/225, 3/230	Non-automatic air circuit breakers	15/19, 15/50 ... 15/56
Capacitor switching capacity for 3NP	17/57	- for switching DC voltage	3/125 ... 3/129, 3/210 ... 3/212, 3/242 ... 3/244	Switching	16/18
Circuit breakers		- for switching resistive loads	3/93 ... 3/108, 3/181, 3/183, 3/184, 3/208, 3/228, 3/241, 3/244	Degree of protection	
Auxiliary trip units	16/12, 16/21	- with extended operating range, for railway applications	3/120 ... 3/125, 3/188 ... 3/190	for 3KA/3KE	17/7, 17/8
Communication-capable	16/17	for switching motors	3/11 ... 3/83, 3/122 ... 3/124, 3/179 ... 3/185, 3/207, 3/239, 3/240, 3/243 ... 3/245	for 3KL	17/24
Electronic trip units	16/7, 16/9, 16/14 ... 16/16, 16/17	- Vacuum contactors	3/55 ... 3/70, 3/185, 3/239, 3/243	for 3KM	17/29
Fixed mounting	16/11	- with DC solenoid system	3/71 ... 3/75, 3/207, 3/240, 3/244	for 3NJ4/3NJ5	17/68
for DC current	16/18	Continuous thermal current		for 3NJ62	17/46
Generator protection	16/9, 16/14 ... 16/15	for 3KA/3KE	17/6	for 3NP	17/57
Molded-case	16/1 ... 16/100	for 3KL	17/24	for PAC3200	13/17
Motor protection	16/9, 16/15 ... 16/16	for 3KM	17/29	for S8	14/7
Operating mechanisms	16/11, 16/22, 16/28, 16/38, 16/46, 16/54, 16/63, 16/100	for 3NJ4/3NJ5	17/68	Degree of protection and safety class	
Plug-in versions	16/11, 16/34 ... 16/35, 16/43 ... 16/45, 16/51, 16/77, 16/82 ... 16/84, 16/89 ... 16/91	Control devices	7/1 ... 7/158	for PAC3200	13/10
RCD modules	16/8, 16/21, 16/73 ... 16/91	Control panel cut-out for PAC3200	13/12	Delay blocks, pneumatic	3/173, 3/174
Shunt trip units	16/12, 16/21	Control transformers	10/2 ... 10/13, 10/22 ... 10/26, 10/31 ... 10/37, 10/44 ... 10/47	Digital inputs for PAC3200	13/9
Starter protection	16/9, 16/14	Converter transformers	10/14 ... 10/16, 10/38 ... 10/41	Digital outputs for PAC3200	13/9
System protection	16/9, 16/14 ... 16/16	Converters	4/44	Dimensional drawings	2/59
Undervoltage trip units	16/12, 16/21	Counter modules	2/87	Dimensions	
Withdrawable version	16/11, 16/36 ... 16/37, 16/52 ... 16/53, 16/55 ... 16/57, 16/64 ... 16/65	Coupling links	3/174, 3/175, 3/192, 3/206, 3/223, 3/239	for PAC3200	13/10, 13/12, 13/16, 13/17
Clearance between phases for 3NJ62	17/47	Coupling relays	3/145 ... 3/147, 3/148 ... 3/158, 3/179, 3/180, 3/182, 3/191, 3/216, 3/217, 3/227, 3/236, 3/248, 3/249	for S8	14/7
Clearances in air and creepage distances	for S8 14/7	Narrow design		Direct current	
Communication for PAC3200	13/9, 13/16, 13/17	- Relay couplers	3/148 ... 3/151, 3/217, 3/248, 3/249	Non-automatic air circuit breakers	15/1 ... 15/2
Communication modules	2/83 ... 2/86	- Relay couplers with plug-in design	3/217, 3/249	Direct-on-line starters	
Communication-capable circuit breakers	15/2, 15/5, 15/12 ... 15/14, 15/20 ... 15/23, 15/30 ... 15/31, 16/17	- Semiconductor couplers	3/153 ... 3/156, 3/217, 3/248, 3/249	3RA11 fuseless load feeders	6/82 ... 6/87
Compact starters		with industrial housing		3RA61 compact feeders	6/90 ... 6/99
400 V AC	6/142 ... 6/147	- Relay couplers	3/157, 3/158, 3/216, 3/249	3RE10 encapsulated starters	6/152 ... 6/158
Configuration		Coupling relays with plug-in relays		F-DS1e-x	6/122 ... 6/123
for 3NJ62	17/43	Plug-in relay couplers	3/159 ... 3/163	Distance protection	5/2, 5/7, 5/20
for PAC3200	13/2	Cover IP20 for 3KL	17/26	Door-coupling rotary operating mechanisms	17/34 ... 17/38
Configuration rules for 3NJ62	17/43	Covers	3/195, 3/198, 3/206, 3/207, 3/209, 16/30, 16/40, 16/47, 16/58, 16/66 ... 16/67, 16/75, 16/80, 16/87	for 3RV1 motor starter protectors	5/2, 5/30, 5/36
Configuring, visualizing and controlling with SIMATIC and SENTRON	18/1 ... 18/5	CP 142-2	2/22	for switch disconnectors	17/36
Connection for LOGO!	2/92	CP 243-2	2/23	Individual parts	17/37
Connection examples for PAC3200	13/13	CP 343-2	2/24	Operating mechanisms for fixed mounting	17/38
Connection modules for contactors	3/197	CP 343-2P	2/25	DP/AS-i F-Link	2/26
Contactorm assemblies	3/84 ... 3/92, 3/200 ... 3/204, 3/207, 3/237, 3/238, 3/240, 3/241	CubicleBUS modules	15/2, 15/4 ... 15/5, 15/12 ... 15/13, 15/16 ... 15/17, 15/20, 15/22, 15/23, 15/30 ... 15/31	DP/AS-i LINK Advanced	2/31
for wye-delta starting	3/86 ... 3/89, 3/91, 3/92, 3/203, 3/204, 3/207, 3/238, 3/241, 5/59, 5/81	Current monitoring	7/69 ... 7/72	DP/AS-Interface Link 20E	2/33
Reversing contactor assemblies	3/84, 3/85, 3/90, 3/200 ... 3/202, 3/207, 3/237, 3/240	Current transformers	16/24 ... 16/25, 16/93, 16/98, 17/48	E	
Contactorm relays	3/120, 3/121, 3/130 ... 3/145, 3/191, 3/192, 3/215, 3/216, 3/226, 3/231 ... 3/235, 3/246			Electrical endurance for 3NJ4/3NJ5	17/68
Latched	3/216, 3/232, 3/235, 3/246			Electromagnetic compatibility for PAC3200	13/11

Subject index

Page	Page	Page
Enclosures for surface mounting		
for 3RV1 motor starter protectors	5/2, 5/38, 5/39	
Endurance for 3NJ62	17/46	
ET 200pro isolator modules	6/139	
ET 200S Safety motor starters	6/121 ... 6/135	
Safety modules local	6/121, 6/124 ... 6/130	
Safety modules PROFIsafe	6/121, 6/131 ... 6/135	
Ethernet for PAC3200	13/9	
ETU electronic trip units	15/2, 15/12 ... 15/17, 15/21, 15/27, 15/30 ... 15/31	
Explosion protection (ATEX)		
3RN1 thermistor motor protection	7/5	
3RV1 motor starter protectors	5/6, 5/14	
Overload relay	5/59, 5/61, 5/72, 5/81, 5/84	
Position switches	8/3	
SIMOCODE pro 3UF7 motor management and control devices	7/5	
Extenders	2/99	
Extension plugs	2/99 ... 2/101	
F		
Fault limits for PAC3200	13/9	
Fixed mounting		
Motor starter protector	15/37, 15/40, 15/41, 15/44, 15/52	
Fixed-mounted circuit breakers	16/11	
Frequency converters	5/59, 5/81	
Front plates for 3RV1 motor starter protectors	5/2, 5/39	
Function modules	4/4, 4/42 ... 4/50	
Converters	4/44	
Heating current monitoring	4/46	
Load monitoring	4/45	
Power controllers	4/47	
Power regulators	4/48	
Fuse monitoring	5/2, 5/9	
Fuse switch disconnectors	17/52 ... 17/70	
1-pole switchable	17/69	
3-pole switchable	17/70	
for extended technical requirements	17/62 ... 17/64	
for power distribution	17/58 ... 17/61	
In-line	17/67 ... 17/70	
Fuseless load feeders		
Infeed systems	6/79 ... 6/81, 6/86	
G		
Generator protection	16/9, 16/14 ... 16/15	
Ground-fault detection modules	2/88, 2/89	
GSM radio elements for signaling columns	9/34	
Guide frames for circuit breakers	15/9 ... 15/11, 15/25 ... 15/26, 15/29, 15/38, 15/42, 15/43, 15/45, 15/46, 15/50, 15/53, 15/54	
H		
Heating current monitoring	4/46	
Hinge switches	8/3, 8/52, 8/54	
Holders for ammeters	17/41	
I		
I/O modules		
for IO-Link	2/107	
for operation in the control cabinet	2/64 ... 2/82, 2/77 ... 2/81	
- F90 modules	2/82	
- Flat modules	2/82	
- SlimLine	2/66 ... 2/76	
for operation in the field	2/34 ... 2/63	
- Analog	2/61 ... 2/63	
- Digital	2/36 ... 2/60	
IE/AS-i LINK PN IO	2/29	
Infeed systems	5/2	
for 3RA6 fuseless compact feeders	6/103 ... 6/109	
for fuseless load feeders	6/79 ... 6/81, 6/86	
Input resistance for PAC3200	13/8	
Installation guidelines		
for 3RV1 molded case motor starter protectors	5/41	
for 3RV1 motor starter protectors	5/7, 5/8	
Insulated three-phase busbar system		
for 3RV1 motor starter protectors	5/2, 5/33 ... 5/35	
Insulation monitoring		
for ungrounded AC networks	7/84, 7/85	
for ungrounded DC networks	7/86, 7/87	
Integrated signal lamps	9/3, 9/38	
Interlocking mechanisms for 3NJ62	17/42	
Interlocks	15/10, 15/19, 16/31, 16/40 ... 16/41, 16/48, 16/58 ... 16/59, 16/68 ... 16/69, 16/71	
Internal circuit diagram for 3KA	17/9	
Internal circuit diagram for 3KE	17/9	
IO-Link	2/106 ... 2/109	
Devices	2/106	
I/O modules	2/107	
Masters	2/106	
Product family	2/106	
Sensors	2/106	
Sensors/actuators	2/106	
System	2/106 ... 2/109	
Technical specifications	2/108	
Isolating features for 3LD	17/14	
Isolating transformers	10/2 ... 10/13, 10/22 ... 10/28, 10/31 ... 10/37, 10/44 ... 10/47	
for supply of medical premises	10/2, 10/19, 10/28	
Resin-enclosed	10/2, 10/18, 10/28	
Isolator modules	5/2, 5/26, 5/33	
L		
Languages for PAC3200	13/9	
Level monitoring		
Level monitoring relays	7/88 ... 7/91	
Level monitoring sensors	7/92	
Line monitoring	7/59 ... 7/64	
Link modules for 3RV1 motor starter protectors	5/2	
Links for paralleling	3/194, 3/198, 3/204, 3/206	
Load feeders	4/5	
3RA1, fuseless	6/63 ... 6/87	
Load monitoring	4/45	
Locking devices	15/10, 15/10, 16/31, 16/41, 16/48, 16/58, 16/69	
Locking devices for contactors	3/209	
LOGO!		
AS-Interface connection	2/92	
Modular basic versions	7/38	
Modular pure versions	7/39	
Software	7/40	
LOGO! logic modules	7/37 ... 7/40	
LOGO!Power	11/2	
M		
Magnetic monitoring systems	8/63, 8/66	
Magnetically operated switches	8/3, 8/63 ... 8/66	
Main and EMERGENCY-STOP switches	17/12 ... 17/22	
Accessories	17/21, 17/22	
Distribution board mounting	17/19	
Floor mounting	17/18	
Molded-plastic enclosures	17/20	
Main conductor connections		
for 3KA/3KE	17/7, 17/9	
for 3KL	17/24	
for 3KM	17/29	
for 3NJ4/3NJ5	17/68	
for 3NJ62	17/46	
for 3NP	17/57	
Main connections	15/7, 15/37 ... 15/46, 16/12	
for circuit breakers	16/29, 16/39, 16/47, 16/57, 16/66, 16/74, 16/79, 16/86	
Mains transformers	10/2 ... 10/16, 10/22 ... 10/26, 10/31 ... 10/37, 10/44 ... 10/47	
Masters		
CP 142-2	2/22	
CP 243-2	2/23	
CP 343-2	2/24	
CP 343-2 P	2/25	
Matching transformers	10/3, 10/14 ... 10/16, 10/38 ... 10/42, 10/46	
with cURus approval	10/3	
with selectable voltages	10/3	
Measurement of variables for PAC3200	13/5	
Measuring category for PAC3200	13/8	
Mechanical dynamic stress for PAC3200	13/11	
Mechanical endurance		
for 3KA/3KE	17/7, 17/8	
for 3KL	17/24	
for 3KM	17/29	
for 3NJ4/3NJ5	17/68	
for 3NP	17/57	
Mechanical interlocks for contactor assemblies	3/199	
Mechanical latching blocks for contactors and contactor relays	3/169, 3/194	
Metal enclosures	8/11 ... 8/19	
Miniature contactors/Power relays	3/164 ... 3/166, 3/204, 3/239, 3/243	
Molded case circuit breakers	16/1 ... 16/100	
Momentary-contact foot switches, foot switches	9/3, 9/30, 9/31	
Monitoring devices	7/1 ... 7/158	

	Page		Page		Page
Monitoring relays for electrical and additional measurements		O		Power consumption for PAC3200	13/8
Current monitoring	7/69 ... 7/72	OFF-delay devices	3/172, 3/192, 3/193, 3/213, 3/215, 3/224	Power controllers	4/47
Insulation monitoring	7/84 ... 7/87	ON-delay devices	3/192	Power distribution board	14/3
Level monitoring	7/88 ... 7/91	Operating mechanisms		Power factor and active current monitoring	7/73 ... 7/77
Level monitoring sensors	7/92	for circuit breakers	15/6, 15/8, 15/27, 16/11, 16/22, 16/28, 16/38, 16/46, 16/54, 16/63, 16/100	Power loss	17/46
Line monitoring	7/59 ... 7/64	Overload relays	5/1, 5/4, 5/55 ... 5/94	for 3KA/3KE	17/9
Power factor and active current monitoring	7/73 ... 7/77	Explosion protection (ATEX)	5/59, 5/61, 5/72, 5/81, 5/84	for 3KL	17/24
Residual current monitoring	7/78 ... 7/82	Overview	17/39	for 3KM	17/29
Speed monitoring	7/93 ... 7/96	Overvoltage category		for 3LD	17/14
Summation current transformers	7/83	for PAC3200	13/8	for 3NJ4/3NJ5	17/68
Voltage monitoring	7/65 ... 7/68	for S8	14/7	for 3NJ62	17/46
Motor protection	16/9, 16/15 ... 16/16	Overvoltage protection modules	2/90, 2/91	for 3NP	17/57
for 3RV1 molded case motor starter protectors	5/3, 5/43			Power modules for ET 200S motor starters	6/117
for 3RV1 motor starter protectors	5/2, 5/8	P		Power regulators	4/48
Motor starter protectors		PAC3200	13/2	Power relays/Miniature contactors	3/164 ... 3/166, 3/204, 3/239, 3/243
Air	15/1 ... 15/56	AC/DC power supply unit with wide voltage range	13/2	Power supplies	11/2 ... 11/15
Communication-capable	15/2, 15/5, 15/12 ... 15/14, 15/20 ... 15/23, 15/30 ... 15/31	DC power supply unit with extra-low voltage	13/2	Filtered	11/2 ... 11/7, 11/10 ... 11/13
Fixed mounting	15/37, 15/40, 15/41, 15/44, 15/52	Ring terminal lug connections	13/10	LOGO!Power	11/2
Guide frames	15/9 ... 15/11, 15/25 ... 15/26, 15/29, 15/38, 15/42, 15/43, 15/45, 15/46, 15/50, 15/53, 15/54	Screw terminals	13/10	Modular	11/2
Operating mechanisms	15/6, 15/8, 15/27	Password protection for PAC3200	13/11	Non-stabilized	11/2 ... 11/15
with electronic trip unit	15/2, 15/12 ... 15/17, 15/21, 15/27, 15/30 ... 15/31	Permanent load capacity for PAC3200	13/8	Single-phase	11/2 ... 11/6, 11/8, 11/10, 11/11, 11/14
Withdrawable bridging units	15/8	Permissible ambient temperature		SITOP	11/2
Withdrawable grounding units	15/8	for 3KA/3KE	17/7, 17/8	Stabilized	11/2
Withdrawable short-circuits	15/8	for 3KL	17/24	Three-phase	11/2 ... 11/5, 11/7, 11/9, 11/12, 11/13, 11/15
Withdrawable version	15/38, 15/42, 15/43, 15/45, 15/46, 15/53, 15/54	for 3KM	17/29	Unfiltered	11/2, 11/8, 11/9, 11/14, 11/15
Motor starters		for 3KN	17/57	Uninterruptible	11/2
24 V DC	6/159 ... 6/162	for 3KA/3KE	17/7, 17/8	Power supply units	
ET 200pro	6/136 ... 6/141	for 3KL	17/24	AS-Interface	2/93 ... 2/95
- Isolator modules	6/139	for 3KM	17/29	with extra-low voltage for PAC3200	13/8
- Safety modules local	6/140, 6/141	for 3LD	17/14	with wide voltage range for PAC3200	13/8
- Standard and High-Feature	6/138	for 3NJ4/3NJ5	17/68	Power transformers	10/2, 10/3, 10/14 ... 10/16, 10/25, 10/38 ... 10/41, 10/46
ET 200S	6/110 ... 6/120	for 3NJ62	17/46	Thermistor transformer protection	10/14, 10/38
- Failsafe	6/122, 6/123	for 3NP	17/57	PROFIBUS	2/110 ... 2/117, 15/2, 15/5, 15/12 ... 15/14, 15/20 ... 15/23, 15/30 ... 15/31
- Power modules	6/117	Permissible let-through current		for 3KA/3KE	17/6, 17/8
- Terminal modules	6/118 ... 6/120	for 3KA/3KE	17/6, 17/8	Permissible load for 3KA/3KE	17/6
Motor starters and load feeders		Permissible mounting positions		for 3KL	17/25
IP65/67	6/159 ... 6/162	for 3KM	17/30	for 3KN	17/30
- Motor starters, 24 V DC	6/159 ... 6/162	for 3NJ62	17/46	for 3NP	17/57
Mounting accessories		Phase failure protection	5/60	for 3KA/3KE	17/7
for 3RV1 molded case motor starter protectors	5/49	Pillar-type variable-ratio transformers	10/2, 10/3	for 3KL	17/25
for 3RV1 motor starter protectors	5/5, 5/26 ... 5/29, 5/32	Plastic enclosures	8/11 ... 8/19	for 3KM	17/30
Mounting clearances for PAC3200	13/12	Plug connectors for PAC3200	13/16, 13/17	Protocols for PAC3200	13/9
Moving-iron measuring devices	17/48	Plug-in bases	3/213, 3/214, 3/215	Protection equipment	5/1 ... 5/94
Multifunction measuring instruments	13/2	Plug-in circuit breakers	16/11	Protective conductor connections	
		Plug-in relays		for 3KA/3KE	17/7
N		Relay couplers	3/218, 3/220, 3/250	for 3KL	17/25
Networks for PAC3200	13/8	Plug-in versions		for 3KM	17/30
Non-automatic air circuit breakers	15/1 ... 15/56	Circuit breakers	16/34 ... 16/35, 16/43 ... 16/45, 16/51, 16/77, 16/82 ... 16/84, 16/89 ... 16/91	Protocols for PAC3200	13/9
Air	15/1 ... 15/56	Pneumatic delay blocks for contactors and contactor relays	3/173, 3/174, 3/193	Pushbutton units and indicator lights	9/2, 9/4 ... 9/24
Direct current	15/1 ... 15/2, 15/19, 15/50 ... 15/56	Position switches	8/2 ... 8/51	Nominal diameter 16 mm	9/4 ... 9/7
Non-stabilized power supplies	11/2 ... 11/15	AS-Interface	8/56 ... 8/62	- Actuators	9/7
Filtered	11/2 ... 11/7, 11/10 ... 11/13	Compact design	8/36, 8/37	- Contact blocks	9/7
Single-phase	11/2 ... 11/6, 11/8, 11/10, 11/11, 11/14	Explosion protection (ATEX)	8/55	Nominal diameter 22 mm	9/8 ... 9/24
Three-phase	11/2 ... 11/5, 11/7, 11/9, 11/12, 11/13, 11/15	Hinge switches	8/52, 8/54	- Actuators	9/8, 9/16 ... 9/20
Unfiltered	11/2, 11/8, 11/9, 11/14, 11/15	Metal enclosures	8/26 ... 8/37	- Contact blocks	9/20 ... 9/23
		Open-type	8/2, 8/38, 8/39	- Enclosures	9/3, 9/13, 9/15, 9/23
		Plastic enclosures	8/20 ... 8/29	- Lamp test	9/24
		with separate actuator	8/2, 8/40 ... 8/46	- Lampholders	9/20 ... 9/23
		with tumbler	8/2, 8/47 ... 8/51	- Protective collars	9/22

Subject index

	Page		Page		Page
R					
Rated breaking capacity	17/46, 17/68	Reactive-power compensation for S8	14/4	SIMATIC WinCC powerrate	18/3, 18/4
for 3NJ4/3NJ5	17/68	Relay couplers 3/148 ... 3/152, 3/157, 3/158, 3/218, 3/220, 3/247, 3/248, 3/250		SIMOCODE pro 3UF7	7/6 ... 7/31
for 3NJ62	17/46	Relays		SIMOCODE pro 3UF7 motor management and control devices	7/6 ... 7/31
Rated conditional short-circuit current		Analogically adjustable, for 1 sensor	7/97 ... 7/103	Explosion protection (ATEX)	7/5
for 3KA/3KE	17/6	Digitally adjustable for up to 3 sensors	7/97 ... 7/99, 7/107 ... 7/109	Single-phase transformers	10/2, 10/4 ... 10/29
for 3KL	17/24	Digitally adjustable, for 1 sensor	7/97 ... 7/99, 7/104 ... 7/106	Auto-	10/2, 10/4 ... 10/16, 10/22, 10/23, 10/25
for 3KM	17/29	Remote motorized operating mechanisms		Control	10/2, 10/4 ... 10/13, 10/22 ... 10/26
for 3NJ4/3NJ5	17/68	for 3RV1 motor starter protectors	5/2, 5/30, 5/31, 5/37	Converter	10/14 ... 10/16
for 3NJ62	17/46	Repeaters	2/98	Enclosed	10/2, 10/17, 10/18
Rated currents		Required operating torque		Enclosures	10/5 10/14, 10/26
for 3NJ62	17/43	for 3KA/3KE	17/7, 17/8, 17/9	Isolating	10/2, 10/4 ... 10/13, 10/22 ... 10/28
for S8	14/7	for 3KM	17/29	- for supply of medical premises	10/2, 10/19, 10/28
Rated diversity factor for 3NJ62	17/43	Residual current monitoring		- Resin-enclosed	10/2, 10/18, 10/28
Rated frequency for 3LD	17/14	Residual current monitoring relays	7/78 ... 7/82	Mains	10/2, 10/4 ... 10/16, 10/22 ... 10/26
Rated impulse voltage		Summation current transformers	7/83	Matching	10/14 ... 10/16
for 3KA/3KE	17/6, 17/8	Reversing contactor assemblies	3/84, 3/85, 3/90, 3/200 ... 3/202, 3/207, 3/237, 3/240	Pillar-type	10/2
for 3KL	17/24	Reversing starters		Power	10/2, 10/14 ... 10/16, 10/25
for 3KM	17/29	3RA12 fuseless load feeders	6/82 ... 6/87	Safety	10/2, 10/4 ... 10/13, 10/22 ... 10/28
for 3NJ62	17/46	3RA62 compact feeders	6/90 ... 6/99	- Resin-enclosed	10/2, 10/17, 10/28
Rated impulse withstand voltage		3RE13 encapsulated starters	6/152 ... 6/158	Thermistor transformer protection	10/14
for 3LD	17/14	F-RS1e-x	6/122 ... 6/123	Toroidal-core	10/2
for S8	14/7	Rotary operating mechanisms		Variable-ratio	10/2
Rated insulation voltage		for 3RV1 motor starter protectors	5/2, 5/30, 5/36	Voltage regulators	
for 3KA/3KE	17/6, 17/8	for 3RV1 molded case motor starter protectors	5/3, 5/50, 5/52, 5/54	- Magnetic-type	10/2, 10/21, 10/30
for 3KL	17/24	Routers		- Transformer-type	10/2, 10/20, 10/29
for 3KM	17/29	DP/AS-i F-Link	2/26	with selectable voltages	10/2, 10/4 ... 10/16, 10/22 ... 10/25
for 3LD	17/14	DP/AS-i LINK Advanced	2/31, 2/32	SIRIUS, modular systems	2/118 ... 2/121
for 3NJ4/3NJ5	17/68	DP/AS-Interface Link 20E	2/33	SITOP	11/2
for 3NJ62	17/46	IE/AS-i LINK PN IO	2/29, 2/30	SIVACON motor control centers	14/3
for S8	14/7	RS485 for PAC3200	13/9	Slaves	
Rated making capacity for 3NJ62	17/46	Safety for PAC3200			
Rated motor power for S8	14/7	Safety modules			
Rated operational current		Safety modules local			
for 3LD	17/14	Safety monitors			
for 3NJ4/3NJ5	17/68	Safety requirements for PAC3200			
for 3NJ62	17/46	Safety transformers			
Rated operational voltage		Resin-enclosed			
for 3KA/3KE	17/6, 17/8	Screw adapters for contactors			
for 3KL	17/24	Semiconductor couplers			
for 3KM	17/29	SENTRON PAC3200			
for 3LD	17/14	SENTRON powerconfig for PAC3200			
for 3NJ62	17/46	Shaped cables			
for S8	14/7	Shock stress for PAC3200			
Rated short-circuit making capacity		Short-circuit protection for 3LD			
for 3KA/3KE	17/6, 17/8	Shunt trip units			
for 3KL	17/24	for 3RV1 molded case motor starter protectors			
for 3KM	17/29	for 3RV1 motor starter protectors			
Rated short-time current		for circuit breakers			
for 3KA/3KE	17/6, 17/8	Signal switches for 3RV1 motor starter protectors			
for 3KL	17/24	for 3RV1 motor starter protectors			
for 3KM	17/29	for 3RV1 motor starter protectors			
for 3LD	17/14	for 3RV1 motor starter protectors			
Rated short-time withstand current		for 3RV1 motor starter protectors			
for 3LD	17/14	for 3RV1 motor starter protectors			
for 3NJ4/3NJ5	17/68	for 3RV1 motor starter protectors			
for S8	14/7	for 3RV1 motor starter protectors			
Rated surge current withstand capability		for 3RV1 motor starter protectors			
for S8	14/7	for 3RV1 motor starter protectors			
Rated uninterrupted current		for 3RV1 motor starter protectors			
for 3KA/3KE	17/6, 17/8	for 3RV1 motor starter protectors			
for 3KL	17/24	for 3RV1 motor starter protectors			
for 3KM	17/29	for 3RV1 motor starter protectors			
for 3LD	17/14	for 3RV1 motor starter protectors			
Rated voltage for PAC3200	13/8	for 3RV1 motor starter protectors			
RCD modules	16/8, 16/21	for 3RV1 motor starter protectors			
for circuit breakers	16/73 ... 16/91	for 3RV1 motor starter protectors			

Subject index

	Page		Page		Page
Stabilized power supplies		Thermistor transformer protection	10/14, 10/38	Trip units	
LOGO!Power	11/2	Three-phase busbar systems for 3RV1 motor starter protectors	5/2, 5/33 ... 5/35	for 3RV1 molded case motor starter protectors	5/42
SITOP	11/2	Three-phase transformers	10/3, 10/31 ... 10/48	for 3RV1 motor starter protectors	5/8
Standards		Auto-	10/3, 10/31 ... 10/41, 10/44, 10/45	Two-hand operation consoles	9/3, 9/25
for 3KA/3KE	17/6	- for matching purposes	10/3, 10/42		
for 3KL	17/24	Control	10/3, 10/31 ... 10/37, 10/44 ... 10/47	U	
for 3KM	17/29	Converter	10/38 ... 10/41	Undervoltage trip units	
for 3LD	17/14	Enclosures	10/32, 10/38, 10/47	for 3RV1 molded case motor starter protectors	5/3, 5/49
for 3NJ4/3NJ5	17/68	Isolating	10/3, 10/31 ... 10/37, 10/44 ... 10/47	for 3RV1 motor starter protectors	5/2, 5/26 ... 5/29
for 3NJ62	17/46	Mains	10/3, 10/31 ... 10/37, 10/44 ... 10/47	for circuit breakers	16/12, 16/21
for 3NP	17/57	Matching	10/3, 10/38 ... 10/42, 10/46	Uninterruptible power supplies	
for S8	14/7	- with cURus approval	10/3	SITOP	11/2
- with selectable voltages	10/3	Pillar-type	10/3	Unit configuration for PAC3200	13/2
Starter combinations		Power	10/3, 10/38 ... 10/41, 10/46	Utilization categories for 3NJ62	17/46
for 3RV1 molded case motor starter protectors	5/3	Safety	10/3, 10/31 ... 10/37, 10/44 ... 10/47		
for 3RV1 motor starter protectors	5/2	Thermistor transformer protection	10/38	V	
Starter protection	16/9, 16/14	Toroidal-core	10/3	Vacuum contactors	3/55 ... 3/70, 3/185, 3/205, 3/239, 3/243
Starters, encapsulated	6/152 ... 6/158	Variable-ratio	10/3	Variable-ratio transformers	
Supply voltage for PAC3200	13/8	Voltage regulators		Pillar-type	10/2, 10/3
Surge overload capability for PAC3200	13/8	- Transformer-type	10/3, 10/43, 10/48	Toroidal-core	10/2, 10/3
Switch disconnectors	17/5 ... 17/71	with selectable voltages	10/3, 10/31 ... 10/41, 10/44 ... 10/46	Vibratory load for PAC3200	13/11
3KA/3KE	17/5 ... 17/11	Tightening torque for 3NP	17/57	Voltage monitoring	7/65 ... 7/68
3KL	17/23 ... 17/27	Time-delay blocks for contactors and contactor relays, solid-state	3/170, 3/225	Voltage regulators	
3KM	17/28 ... 17/33	Toroidal-core variable-ratio transformers	10/2, 10/3	Magnetic-type	10/2, 10/21, 10/30
3LD	17/12 ... 17/22	Touch protection for 3LD	17/14	Transformer-type	10/2, 10/3, 10/20, 10/29, 10/43, 10/48
3NJ4/3NJ5	17/65 ... 17/71	Transformer protection	5/2, 5/9	Voltage transformer motor starter protectors	5/2, 5/7, 5/10, 5/20
3NJ62	17/39 ... 17/51	Transformers	10/2 ... 10/48		
3NP	17/52 ... 17/64	Auto-	10/2 ... 10/16, 10/22, 10/23, 10/25, 10/31 ... 10/41, 10/44, 10/45	W	
- for matching purposes	10/3, 10/42	- for matching purposes	10/3, 10/42	Weight for 3KM	17/30
Fuse switch disconnectors	17/52 ... 17/70	Control	10/2 ... 10/13, 10/22 ... 10/26, 10/31 ... 10/37, 10/44 ... 10/47	Weights for PAC3200	13/10, 13/16
- for extended technical requirements	17/62 ... 17/64	Converter	10/14 ... 10/16, 10/38 ... 10/41	Withdrawable bridging units	15/8
- for power distribution	17/58 ... 17/61	Enclosed	10/2, 10/17, 10/18	Withdrawable grounding units	15/8
- In-line	17/67 ... 17/70	Enclosures	10/5, 10/14, 10/26, 10/32, 10/38, 10/47	Withdrawable short-circuits	15/8
Main and EMERGENCY-STOP switches	17/12 ... 17/22	Isolating	10/2 ... 10/13, 10/22 ... 10/28, 10/31 ... 10/37, 10/44 ... 10/47	Withdrawable versions	
with fuses	17/23 ... 17/33	- for supply of medical premises	10/2, 10/19, 10/28	Circuit breakers	16/11, 16/36 ... 16/37, 16/52 ... 16/53, 16/55 ... 16/57, 16/64 ... 16/65
- Surface mounting and installation	17/26, 17/27	- Resin-enclosed	10/2, 10/18, 10/28	Motor starter protector	15/38, 15/42, 15/43, 15/45, 15/46, 15/53, 15/54
- with isolating plug connector	17/28 ... 17/33	Mains	10/2 ... 10/16, 10/22 ... 10/26, 10/31 ... 10/37, 10/44 ... 10/47		
Switch ES Power	18/5	Matching	10/3, 10/14 ... 10/16, 10/38 ... 10/42, 10/46	Z	
Switch position indicator for 3NJ62	17/42	- with cURus approval	10/3	Zero point suppression for PAC3200	13/8
Switchgear	14/3	- with selectable voltages	10/3		
Switching capacity	17/46	Pillar-type	10/2, 10/3		
for 3KA/3KE	17/8	Power	10/2, 10/3, 10/14 ... 10/16, 10/25, 10/38 ... 10/41, 10/46		
for 3KL	17/24	Safety	10/2 ... 10/13, 10/22 ... 10/28, 10/31 ... 10/37, 10/44 ... 10/47		
for 3KM	17/29	- Resin-enclosed	10/2, 10/17, 10/28		
for 3NJ62	17/46	Single-phase	10/2, 10/4 ... 10/29		
Switching examples for 3NJ62	17/49	Thermistor transformer protection	10/14, 10/38		
Switching frequency for 3LD	17/14	Three-phase	10/3, 10/31 ... 10/48		
System components and accessories		Toroidal-core	10/2, 10/3		
Addressing units	2/102	Variable-ratio	10/2, 10/3		
Analyzers	2/103	Voltage regulators			
Extension plugs	2/99 ... 2/101	- Magnetic-type	10/2, 10/21, 10/30		
- Transformer-type	10/2, 10/3, 10/20, 10/29, 10/43, 10/48				
System protection 5/2, 5/9, 16/9, 16/14 ... 16/16		with selectable voltages	10/2, 10/3, 10/4 ... 10/16, 10/22 ... 10/25, 10/31 ... 10/41, 10/44 ... 10/46		
T		Transmission media, shaped cables	2/96		
Terminal brackets	5/69, 5/94	Transmission rate for PAC3200	13/9, 13/16, 13/17		
Terminal modules for ET 200S motor starters	6/118 ... 6/120				
Terminal screws for 3NP	17/57				
Terminals					
for "Self-Protected Combination Motor Controller" according to UL 508	5/32, 5/37				
for 3RV1 molded case motor starter protectors	5/45, 5/50, 5/51, 5/53				
Position of terminals					
- for 3NJ62	17/51				

Appendix

Order No. index

Order No.	Page	Order No.	Page	Order No.	Page
3K		3RK1 400	2/36 ... 60, 2/66 ... 76, 2/82 ... 86, 2/92, 6/76 ... 78, 6/159 ... 162	3RW40	6/17 ... 31, 6/53, 6/56 ... 58
3KA	17/5, 17/7, 17/10	3RK1 402	2/66 ... 76	3RW44	6/32 ... 51, 6/54 ... 55, 6/59 ... 62
3KE	17/8 ... 9, 17/11	3RK1 405	2/16 ... 21	3RX9 0	2/96
3KL	17/23 ... 27	3RK1 408	2/36 ... 44, 2/88 ... 89	3RX9 5	2/93 ... 95
3KM	17/28 ... 33	3RK1 901	2/43, 2/47, 2/52, 2/59, 2/90 ... 91, 2/99	3S	
3KX	17/10 ... 11	3RK2 100	2/48 ... 52	3SB2	9/2, 9/4 ... 7
3L		3RK2 200	2/36 ... 44, 2/48 ... 60, 2/66 ... 76	3SB3	9/2, 9/8 ... 24
3LD2	17/12 ... 20	3RK2 207	2/61 ... 63	3SB34	9/11 ... 12, 9/20 ... 24
3LD9	17/21 ... 22	3RK2 400	2/36 ... 44, 2/48 ... 60, 2/66 ... 76	3SB38	9/3, 9/12 ... 13, 9/23, 9/25
3N		3RK3	7/147 ... 154	3SB39	9/25
3NJ4	17/67 ... 70	3RK5	2/107	3SE21	8/6 ... 35, 8/40 ... 41
3NJ5	17/67 ... 69, 17/71	3RN10	7/110 ... 115	3SE22	8/6 ... 35, 8/40 ... 46, 8/54
3NJ62	17/39 ... 51	3RP15	3/238, 3/241, 7/41 ... 51	3SE28	8/47, 8/51
3NJ69	17/48	3RP20	7/41 ... 43, 7/52 ... 54	3SE29	9/3, 9/30 ... 31
3NP4	17/53 ... 54, 17/58 ... 60, 17/64	3RS10 00	7/97 ... 103	3SE30	8/39
3NP5	17/55 ... 57, 17/62 ... 64	3RS10 10	7/97 ... 103	3SE31	8/36 ... 37
3NY1	17/58, 17/62	3RS10 10	7/97 ... 103	3SE32	8/40 ... 46
3NY7	17/59, 17/61	3RS10 20	7/97 ... 103	3SE37	8/47 ... 49
3P		3RS10 30	7/97 ... 103	3SE38	8/47
3PB74	3/156	3RS10 40	7/97 ... 99, 7/104 ... 106	3SE39	9/30 ... 31
3PG74	3/156	3RS10 41	7/97 ... 99, 7/107 ... 109	3SE6	8/63 ... 66
3R		3RS10 42	7/97 ... 99, 7/104 ... 106	3SE7	9/3, 9/26 ... 29
3RA1	6/63 ... 87	3RS11 00	7/97 ... 103	3SF2	9/3
3RA13	3/84 ... 85, 3/200 ... 202, 3/237	3RS11 01	7/97 ... 103	3SF58	9/15
3RA14	3/86 ... 89, 3/203 ... 204, 3/238	3RS11 20	7/97 ... 103	3T	
3RA19	3/199 ... 201, 3/237	3RS11 21	7/97 ... 103	3TB5	3/71 ... 75, 3/124, 3/207, 3/212, 3/240, 3/243 ... 244
3RA6	6/88 ... 109	3RS11 40	7/97 ... 99, 7/104 ... 106	3TC	3/125 ... 129, 3/210 ... 212, 3/242, 3/244
3RB19	5/6	3RS11 42	7/97 ... 99, 7/104 ... 106	3TD6	3/90, 3/207, 3/240
3RB20	5/4, 5/55 ... 58, 5/70 ... 79	3RS17	7/155 ... 158	3TE6	3/91 ... 92, 3/207, 3/241
3RB21	5/4, 5/55 ... 58, 5/70 ... 79	3RS18	3/157 ... 158, 3/216, 3/249	3TF2	3/76 ... 83, 3/213, 3/245
3RB22	5/4, 5/55 ... 58, 5/80 ... 93	3RS20 40	7/97 ... 99, 7/104 ... 106	3TF6	3/64 ... 70, 3/205, 3/239, 3/243
3RB23	5/4, 5/55 ... 58, 5/80 ... 93	3RS21 40	7/97 ... 99, 7/104 ... 106	3TG10	3/164 ... 166, 3/204, 3/243
3RB29	5/94	3RT1	3/5 ... 63, 3/228	3TH2	3/141 ... 144, 3/215 ... 216, 3/246
3RE1	6/152 ... 158	3RT10	3/11 ... 54, 3/122 ... 123, 3/146 ... 147, 3/179 ... 184, 3/188 ... 190, 3/221, 3/225, 3/227, 3/231	3TH4	3/121, 3/137 ... 140, 3/192, 3/232, 3/234
3RF20	4/2, 4/6, 4/13 ... 16	3RT12	3/55 ... 63, 3/185	3TK1	3/106 ... 108, 3/208, 3/241, 3/244
3RF21	4/2, 4/6 ... 12	3RT13	3/102 ... 105, 3/186, 3/221, 3/228	3TK20	3/109 ... 115, 3/214
3RF22	4/2, 4/6, 4/17 ... 22	3RT14	3/93 ... 101, 3/181, 3/183 ... 184, 3/227	3TK28 10	7/116 ... 117, 7/143 ... 146
3RF23	4/2, 4/23 ... 32	3RT15	3/116 ... 117, 3/186, 3/221, 3/228	3TK28 21	7/116 ... 117, 7/127 ... 137
3RF24	4/2, 4/6, 4/23, 4/33 ... 41, 4/53 ... 58, 4/59 ... 64	3RT16	3/118 ... 119, 3/187, 3/225, 3/230	3TK28 22	7/116 ... 117, 7/127 ... 137
3RF29	4/2, 4/42 ... 50	3RT19	3/169 ... 175, 3/193 ... 198, 3/204, 3/222 ... 3/225, 3/229 ... 230, 3/238, 5/18, 5/32, 5/37, 7/44, 7/55 ... 58	3TK28 23	7/116 ... 117, 7/127 ... 137
3RG9	2/77 ... 81, 2/83 ... 86	3RU11	5/4, 5/55 ... 68	3TK28 24	7/116 ... 117, 7/127 ... 137
3RH1	3/130 ... 136	3RU19	5/69	3TK28 25	7/116 ... 117, 7/127 ... 137
3RH11	3/120, 3/145, 3/191, 3/225, 3/231 ... 232, 3/235 ... 236	3RV10	5/2 ... 3, 5/5 ... 18, 5/21 ... 23, 5/25, 5/40 ... 49, 5/51 ... 54	3TK28 26	7/116 ... 117, 7/127 ... 137
3RH12	3/232	3RV11	5/2 ... 3, 5/5 ... 12, 5/14 ... 16, 5/21, 5/23 ... 25	3TK28 27	7/116 ... 117, 7/127 ... 137
3RH14	3/136, 3/191, 3/232, 3/235	3RV13	5/2 ... 3, 5/5 ... 16, 5/21 ... 23, 5/25, 5/40 ... 54	3TK28 28	7/116 ... 117, 7/127 ... 137
3RH19	3/196 ... 197, 3/221 ... 223, 3/227 ... 232	3RV14	5/2, 5/5 ... 12, 5/14 ... 15, 5/21 ... 22, 5/25	3TK28 30	7/116 ... 117, 7/127 ... 137
3RK1 100	2/36 ... 44, 2/48 ... 52, 2/66 ... 76	3RV16	5/2, 5/5 ... 12, 5/14 ... 16, 5/20 ... 22, 5/25	3TK28 34	7/116 ... 117, 7/127 ... 137
3RK1 107	2/61 ... 63	3RV17	5/2, 5/5 ... 12, 5/14 ... 15, 5/19, 5/21, 5/24 ... 25	3TK28 35	7/116 ... 117, 7/127 ... 137
3RK1 200	2/36 ... 44, 2/48 ... 52, 2/66 ... 76, 2/83 ... 87	3RV18	5/2, 5/5 ... 12, 5/14 ... 15, 5/19, 5/21, 5/24 ... 5/25	3TK28 40	7/116 ... 125
3RK1 205	2/16 ... 21, 2/53 ... 60	3RV19	5/2 ... 3, 5/5, 5/20, 5/26 ... 39, 5/49 ... 54, 6/79 ... 81, 6/86	3TK28 41	7/116 ... 125
3RK1 207	2/61 ... 63	3RW30	6/4 ... 16, 6/52	3TK28 42	7/116 ... 125
3RK1 301	6/110 ... 135			3TK28 45	7/116 ... 126
3RK1 303	6/148 ... 151			3TK28 5	7/116 ... 117, 7/138 ... 142
3RK1 304	6/136 ... 141			3TX2	3/211
3RK1 322	6/142 ... 147			3TX4	3/176 ... 177, 3/192, 3/213 ... 215, 3/234, 3/245 ... 246
3RK1 323	6/148 ... 151			3TX7	3/148 ... 156, 3/175, 3/206 ... 207, 3/217, 3/239, 3/247 ... 249
				3TY6	3/240
				3TY7	3/239, 3/243

Order No. index

Order No.	Page	Order No.	Page	Order No.	Page
3U		3W		5S	
3UF18	7/32 ... 36	3WL1	15/1 ... 48, 15/50 ... 56	5SF6	17/90
3UF7	7/6 ... 31	3WL9	15/1 ... 36	5SG6	17/90
3UG30 81	7/84 ... 85	3Z		5SH2	17/90
3UG30 82	7/86 ... 87	3ZS2	18/1 ... 5	5SH3	17/81
3UG32 07	7/92	4A		5SH5	17/90
3UG45 01	7/88 ... 91	4AM	10/2, 10/4 ... 13, 10/22 ... 23, 10/25 ... 26	6E	
3UG45 11	7/59 ... 64	4AP	10/3, 10/31 ... 37, 10/42, 10/44 ... 47	6ED1	7/37 ... 40
3UG45 12	7/59 ... 64	4AT	10/2, 10/4 ... 13, 10/19, 10/24 ... 28	6EP1	11/2
3UG45 13	7/59 ... 64	4AU	10/3, 10/31 ... 37, 10/42, 10/45 ... 47	6ES7	2/22 ... 25
3UG46 14	7/59 ... 64	4AV2	11/2 ... 6, 11/10 ... 11	6G	
3UG46 15	7/59 ... 64	4AV3	11/2 ... 5, 11/7, 11/12 ... 13	6GK1	2/22 ... 25, 2/98
3UG46 16	7/59 ... 64	4AV4	11/2 ... 6, 11/11	6GK1 411	2/29 ... 30
3UG46 17	7/59 ... 64	4AV5	11/2 ... 5, 11/7, 11/13	6GK1 415	2/31 ... 33
3UG46 18	7/59 ... 64	4AV96	11/2, 11/9, 11/15	6GK7	2/22 ... 25
3UG46 21	7/69 ... 72	4AV98	11/2, 11/8, 11/14	6ZS2	13/2 ... 17
3UG46 22	7/69 ... 72	4AX22	10/2, 10/17, 10/28	7K	
3UG46 24	7/78 ... 82	4AX23	10/2, 10/17, 10/28	7KM2	13/2 ... 17
3UG46 31	7/65 ... 68	4AX24	10/2, 10/18, 10/28	7KM9	13/2 ... 17
3UG46 32	7/65 ... 68	4B		8U	
3UG46 33	7/65 ... 68	4BT	10/2, 10/14 ... 16, 10/25, 10/27	8UC	16/92
3UG46 41	7/73 ... 77	4BU	10/3, 10/38 ... 41, 10/47	8UC6	17/37
3UG46 51	7/93 ... 96	4C		8UC7	17/34 ... 37
3UL22	7/83	4CH	10/2	8UC9	17/37 ... 38
3V		4CJ	10/3	8US	17/72 ... 91
3VF2	16/99 ... 100	4CP	10/2	8US10	17/76 ... 78
3VF9	16/99 ... 100	4CQ	10/3	8US11	17/87
3VL1	16/1 ... 35, 16/71 ... 77, 16/94 ... 98	4F		8US12	17/85, 17/87 ... 89
3VL2	16/1 ... 37, 16/71 ... 72, 16/78 ... 84, 16/94 ... 98	4FK	10/2, 10/21, 10/30	8US19	17/74 ... 75, 17/78 ... 79, 17/83 ... 86, 17/91
3VL3	16/1 ... 37, 16/71 ... 72, 16/78 ... 84, 16/94 ... 98	4FL	10/2 ... 3, 10/20, 10/29, 10/43, 10/48	8W	
3VL4	16/1 ... 26, 16/38 ... 45, 16/71 ... 72, 16/85 ... 98	4N		8WD42	9/32 ... 36
3VL5	16/1 ... 26, 16/46 ... 53, 16/71, 16/94 ... 98	4NC	16/24 ... 25, 16/93, 16/98	8WD44	9/32 ... 35, 9/37
3VL6	16/1 ... 26, 16/54 ... 61, 16/71, 16/94 ... 98	L		8WD54	9/38
3VL7	16/1 ... 26, 16/62 ... 70, 16/94 ... 98	LZS			
3VL8	16/1 ... 26, 16/62 ... 70, 16/94 ... 98			3/218, 3/250	
3VL9	16/1 ... 17, 16/27 ... 98				

Conditions of sale and delivery Export regulations

Terms and Conditions of Sale and Delivery

By using this catalog you can acquire hardware and software products described therein from Siemens AG subject to the following terms. Please note! The scope, the quality and the conditions for supplies and services, including software products, by any Siemens entity having a registered office outside of Germany, shall be subject exclusively to the General Terms and Conditions of the respective Siemens entity. The following terms apply exclusively for orders placed with Siemens AG.

For customers with a seat or registered office in Germany

The "General Terms of Payment" as well as the "General Conditions for the Supply of Products and Services of the Electrical and Electronics Industry" shall apply.

For software products, the "General License Conditions for Software Products for Automation and Drives for Customers with a Seat or registered Office in Germany" shall apply.

For customers with a seat or registered office outside of Germany

The "General Terms of Payment" as well as the "General Conditions for Supplies of Siemens. Automation and Drives for Customers with a Seat or registered Office outside of Germany" shall apply.

For software products, the "General License Conditions for Software Products for Automation and Drives for Customers with a Seat or registered Office outside of Germany" shall apply.

General

The dimensions are in mm. In Germany, according to the German law on units in measuring technology, data in inches only apply to devices for export.

Illustrations are not binding.

Insofar as there are no remarks on the corresponding pages, - especially with regard to data, dimensions and weights given - these are subject to change without prior notice.

The prices are in € (Euro) ex works, exclusive packaging.

The sales tax (value added tax) is not included in the prices. It shall be debited separately at the respective rate according to the applicable legal regulations.

Prices are subject to change without prior notice. We will debit the prices valid at the time of delivery.

Surcharges will be added to the prices of products that contain silver, copper, aluminum, lead and/or gold if the respective basic official prices for these metals are exceeded. These surcharges will be determined based on the official price and the metal factor of the respective product.

The surcharge will be calculated on the basis of the official price on the day prior to receipt of the order or prior to the release order.

The metal factor determines the official price as of which the metal surcharges are charged and the calculation method used. The metal factor, provided it is relevant, is included with the price information of the respective products.

An exact explanation of the metal factor and the text of the Comprehensive Terms and Conditions of Sale and Delivery are available free of charge from your local Siemens business office under the following Order Nos.:

- 6ZB5310-0KR30-0BA1
(for customers based in Germany)
- 6ZB5310-0KS53-0BA1
(for customers based outside Germany)

or download them from the Internet
<http://www.siemens.com/automation/mail>
(Germany: A&D Mall Online-Help System)

Export regulations

The products listed in this catalog / price list may be subject to European / German and/or US export regulations.

Therefore, any export requiring a license is subject to approval by the competent authorities.

According to current provisions, the following export regulations must be observed with respect to the products featured in this catalog / price list:

AL	Number of the <u>German Export List</u> Products marked other than "N" require an export license. In the case of software products, the export designations of the relevant data medium must also be generally adhered to. Goods labeled with an " <u>AL not equal to N</u> " are subject to a European or German export authorization when being exported out of the EU.
ECCN	<u>Export Control Classification Number</u> Products marked other than "N" are subject to a reexport license to specific countries. In the case of software products, the export designations of the relevant data medium must also be generally adhered to. Goods labeled with an " <u>ECCN not equal to N</u> " are subject to a US re-export authorization.

Even without a label or with an "AL: N" or "ECCN: N", authorization may be required due to the final destination and purpose for which the goods are to be used.

The deciding factors are the AL or ECCN export authorization indicated on order confirmations, delivery notes and invoices.

Errors excepted and subject to change without prior notice.

A&D/VuL_ohne MZ/En 05.09.06

Appendix

Notes

Appendix

Notes



Industry Automation, Drive Technologies and Electrical Installation Technology

Further information can be obtained from our branch offices listed in the appendix or at www.siemens.com/automation/partner

Automation and Drives	<i>Catalog</i>	Low-Voltage	<i>Catalog</i>
Interactive catalog on DVD	CA 01	Controls and Distribution – SIRIUS, SENTRON, SIVACON	LV 1
Drive Systems		Controls and Distribution – Technical Information SIRIUS, SENTRON, SIVACON	LV 1 T
<u>Variable-Speed Drives</u>		SIDAC Reactors and Filters	LV 60
SINAMICS G110/SINAMICS G120	D 11.1	SIVENT Fans	LV 65
Inverter Chassis Units		SIVACON 8PS Busbar Trunking Systems	LV 70
SINAMICS G120D			
Distributed Frequency Inverters			
SINAMICS G130 Drive Converter Chassis Units, SINAMICS G150 Drive Converter Cabinet Units	D 11		
SINAMICS GM150/SINAMICS SM150 Medium-Voltage Converters	D 12		
SINAMICS S150 Drive Converter Cabinet Units	D 21.3	Process Instrumentation and Analytics	
Asynchronous Motors Standardline	D 86.1	Field Instruments for Process Automation	FI 01
Synchronous Motors with Permanent-Magnet Technology, HT-direct	D 86.2	Measuring Instruments for Pressure, Differential Pressure, Flow, Level and Temperature, Positioners and Liquid Meters	
DC Motors	DA 12	<i>PDF: Indicators for panel mounting</i>	MP 12
SIMOREG DC MASTER 6RA70 Digital Chassis Converters	DA 21.1	SIREC Recorders and Accessories	MP 20
SIMOREG K 6RA22 Analog Chassis Converters	DA 21.2	SIPART, Controllers and Software	MP 31
<i>PDF: SIMOREG DC MASTER 6RM70 Digital Converter Cabinet Units</i>	DA 22	SIWAREX Weighing Systems	WT 01
SIMOVERT PM Modular Converter Systems	DA 45	Continuous Weighing and Process Protection	WT 02
SIEMOSYN Motors	DA 48	Process Analytical Instruments	PA 01
MICROMASTER 420/430/440 Inverters	DA 51.2	<i>PDF: Process Analytics, Components for the System Integration</i>	PA 11
MICROMASTER 411/COMBIMASTER 411	DA 51.3		
SIMOVERT MASTERDRIVES Vector Control	DA 65.10	SIMATIC HMI	
SIMOVERT MASTERDRIVES Motion Control	DA 65.11	Human Machine Interface Systems	ST 80
Synchronous and asynchronous servomotors for SIMOVERT MASTERDRIVES	DA 65.3		
SIMODRIVE 611 universal and POSMO	DA 65.4	SIMATIC Industrial Automation Systems	
<u>Low-Voltage Three-Phase-Motors</u>		Products for Totally Integrated Automation and Micro Automation	ST 70
IEC Squirrel-Cage Motors	D 81.1	SIMATIC PCS 7 Process Control System	ST PCS 7
MOTOX Geared Motors	D 87.1	Add-ons for the SIMATIC PCS 7 Process Control System	ST PCS 7.1
<u>Automation Systems for Machine Tools SIMODRIVE</u>	NC 60	Migration solutions with the SIMATIC PCS 7 Process Control System	ST PCS 7.2
• Motors		pc-based Automation	ST PC
• Converter Systems SIMODRIVE 611/POSMO		SIMATIC Control Systems	ST DA
<u>Automation Systems for Machine Tools SINAMICS</u>	NC 61		
• Motors			
• Drive System SINAMICS S120		SIMATIC NET	
SIMOTION, SINAMICS S120 and Motors for Production Machines	PM 21	Industrial Communication	IK PI
<u>Drive and Control Components for Hoisting Equipment</u>	HE 1		
<u>Mechanical Driving Machines</u>		SIMATIC Sensors	
Flender Standard Couplings	MD 10.1	Sensors for Factory Automation	FS 10
Electrical Installation Technology			
<i>PDF: ALPHA Distribution Boards and Terminal Blocks</i>	ETA 1		
<i>PDF: ALPHA 8HP Molded-Plastic Distribution System</i>	ETA 3	Systems Engineering	
<i>PDF: BETA Low-Voltage Circuit Protection</i>	ET B1	Power supplies SITOP power and LOGO! Power	KT 10.1
<i>PDF: DELTA Switches and Socket Outlets</i>	ET D1	System cabling SIMATIC TOP connect	KT 10.2
<i>PDF: GAMMA Building Management Systems</i>	ET G1		
Motion Control		System Solutions	
SINUMERIK & SIMODRIVE Automation Systems for Machine Tools	NC 60	Applications and Products for Industry are part of the interactive catalog CA 01	
SINUMERIK & SINAMICS Automation Systems for Machine Tools	NC 61		
SIMOTION, SINAMICS S120 and Motors for Production Machines	PM 21	TELEPERM M Process Control System	
		<i>PDF: AS 488/TM automation systems</i>	PLT 112

PDF: These catalogs are only available as pdf files.

Get more information

Low-Voltage Controls and Distribution
www.siemens.com/lowvoltage

Siemens AG
Industry Sector
Low-Voltage Controls and Distribution
Postfach 48 48
90026 NÜRNBERG
GERMANY

Subject to change without prior notice
Order No. E86060-T1002-A101-A8-7600
3P.8103.50.23 / Dispo 68201
KG 0209 10. KRD 1344 En
Printed in Germany
© Siemens AG 2009

www.siemens.com/automation

The information provided in this catalog contains descriptions or characteristics of performance which in case of actual use do not always apply as described or which may change as a result of further development of the products. An obligation to provide the respective characteristics shall only exist if expressly agreed in the terms of contract. Availability and technical specifications are subject to change without notice.

All product designations may be trademarks or product names of Siemens AG or supplier companies whose use by third parties for their own purposes could violate the rights of the owners.

Token fee: 15.00 €