

Process Protection



6/2	Product overview
6/3	Acoustic and Motion sensing
6/5	Acoustic sensors for pump monitoring SITRANS DA400
6/10 6/14	Acoustic sensors for material flow monitoring SITRANS AS100 SITRANS CU02
6/17 6/23 6/26	Motion sensors Milltronics MFA 4p Milltronics Millpulse 600 SITRANS WM100

You can download all instructions, catalogs and certificates for Process Protection free of charge at:
www.siemens.com/processprotection

Process Protection

Product overview

Overview

	Application	Device description	Page
Acoustic sensor for pump monitoring			
	Acoustic diagnostics unit for flow valve leakage monitoring in oscillating displacement pumps or for material flow monitoring of bulk solids in pipes, conveyors or raceways.	SITRANS DA400 <ul style="list-style-type: none"> • 4 inputs for structure-born noise sensors • 4 universal inputs • 6 digital outputs • With PROFIBUS DP or PROFIBUS PA • Sensor degree of protection IP66/IP68 	6/5
Acoustic sensors for material flow monitoring			
	Acoustic sensor for solids flow detection	SITRANS AS100 <ul style="list-style-type: none"> • Non-invasive • Screw in, bolt on, weld, or bond in place • Analog output • High and low sensitivity range of operation 	6/10
	Alarm control unit for use with SITRANS AS100 acoustic sensor to provide reliable continuous protection for bulk solid flow It processes signals from the sensor, providing relay and analog outputs for interface into a process.	SITRANS CU02 <ul style="list-style-type: none"> • 3 digit LCD display • 4 ... 20 mA output • Two programmable relays • Adjustable independent time delay for each relay • DIN rail mounting provides easy installation 	6/14
Motion sensors			
	Highly sensitive single set point motion sensor alarm unit, used with MSP and XPP probes	Milltronics MFA 4p <ul style="list-style-type: none"> • Probe/target separation up to 100 mm (4 inch) • Minimum velocity of moving ferrous target: 1 cm/sec. (2 fpm) 	6/17
	Heavy-duty 2-wire motion sensor providing solid state switch output to PLCs between 18 ... 135 V AC or DC	Milltronics Millpulse 600 <ul style="list-style-type: none"> • Provide pulse output to PLC input when monitoring speed of rotating, reciprocating or conveying equipment 	6/23
	Heavy-duty zero speed alarm switch	Milltronics SITRANS WM100 <ul style="list-style-type: none"> • Detects the absence or presence of motion of rotating or reciprocating or conveying equipment 	6/26

Overview

Process protection devices act as early warning systems to avoid costly process interruptions and breakdowns of equipment. Non-contacting motion sensors detect changes in motion and speed of conveying, reciprocating and rotating machinery.

Non-invasive acoustic sensors detect inaudible, high frequency acoustic emissions generated by friction and impact, caused by materials in motion. They can detect conditions of flow/no flow or high/low flow, to warn of blockages, product absence or equipment failure. They are located outside of the process, accurately detecting conditions without wear on the sensor.

Motion sensors can warn in case of equipment malfunction and shut down machinery in case of a slowdown or failure. They are rugged and perform even in harsh industrial conditions. Most of the MFA 4p motion sensing probes as well as the Millpulse 600 and the SITRANS WM100 can be mounted up to 100 mm (4 inch) from the ferrous target, reducing the chance of damage to the probe and the equipment. The probes are not affected by moisture or dust build-up.

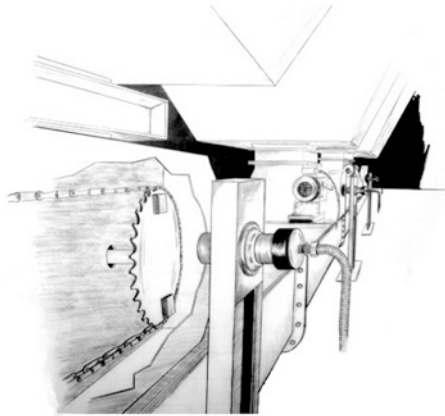

Motion sensing on drive shaft of rotary feeder

Mode of operation

Acoustic Sensing

Acoustic sensors monitor high frequency emissions generated by friction and the impact of flowing material or mechanical parts. The sensors can also sense the turbulence of gases or liquids leaking through valves and flanges. When matter vibrates between 0 Hz and 200 kHz, it creates acoustic energy. Sound energy between 20 Hz and 20 kHz can be detected by humans. Acoustic sensors detect high-frequency acoustic energy between 75 kHz and 175 kHz. Acoustic energy travels quickly through dense materials (metal) and poorly through less dense materials (air). Because the acoustic sensors are mounted directly to the external wall of the chute work, other plant noises are well below 75 kHz and effectively ignored by the sensors.

The acoustic sensors contain a specialized piezocrystal and filter circuit that responds effectively to the high-frequency band between 75 kHz and 175 kHz. As the crystal is excited by the acoustic energy, it produces a continuous electrical signal in direct proportion to the level of acoustic energy received. The SITRANS AS100 sensor output of 0 to 10 V DC can be applied to a PLC or to an optional control unit for a programmable alarm relay or 4 to 20 mA signal output.

Motion sensing

Siemens Milltronics probes work on the principle of Faraday's Laws of Electromagnetic Induction. When a ferromagnetic object enters the probe's permanent magnetic field, it distorts the flux, causing its coil windings to generate a voltage. This voltage is proportional to the strength of the magnet and the number of wire turns in the coil (constant in the probes) and the speed at which the ferrous target passes through the flux. The generated voltage is also inversely proportional to the square of the distance between the target and the probe.

The robust motion sensors provide the contacts to shut down machinery whenever under-speed, over-speed or plant equipment failure occurs. On belt, drag and screw conveyors, or on bucket elevators, fans and pumps, the speed alarm option can warn instantly of equipment malfunction. Some probes may be linked to a programmable logic controller to monitor equipment.

Process Protection

Acoustic and Motion sensing

Technical specifications

Process Protection Selection Guide

Criteria	SITRANS DA400	SITRANS AS100	Milltronics MFA 4p	Milltronics Millpulse 600	SITRANS WM100
Typical industries	Mining, water/waste-water, chemicals/petrochemicals and oil & gas industry	Aggregates, grain, cement, food processing, power generation, steel processing	Aggregates, cement, mining, wastewater, grain	Aggregates, cement, mining	Aggregates, cement, mining
Typical Applications	Oscillating displacement pumps such as diaphragm piston pumps, piston pumps and hose-type diaphragm piston pumps. Monitoring of flowing materials in pipes, conveyors or channels.	Pipes, pneumatic conveyors, aerated gravity flow systems, burst filter bag detection	Tail pulleys, driven pulleys, motor shaft sensing, screw conveyor flights, bucket elevators	Tail pulleys, driven pulleys, motor shaft sensing, screw conveyor flights, bucket elevators	Tail pulleys, driven pulleys, motor shaft sensing, screw conveyor flights, bucket elevators
Operation	Acoustic detection of cavitation, optionally acoustic detection of impact noises of high frequency	Acoustic sensing	Motion sensing	Motion sensing	Motion sensing
Enclosure	Electronics housing, Makrolon IP65, sensor, stainless steel material number W.-Nr. 1.4571 (316Ti SST)	Compact 304 or 303 stainless steel, IP68	Type 4X/NEMA 4X/IP65 polycarbonate	Type 4X/NEMA 4X/IP67 aluminum	Type 4X/NEMA 4X/IP67 aluminum
Sensor mounting	Screw to outside of pump housing. For material flow monitoring on the outside of pipes, channels, chutes or raceways	Sensor non-invasive: glue or weld-on disc, bolt or weld-on tab, drill and tap	Non-contacting probes secured with supplied flange	Non-contacting, secured with supplied flange	Non-contacting, secured with supplied flange
Operating temperature	Electronics -20 °C ... +60 °C (-4 °F ... +140 °F) Sensor -20 °C ... +110 °C (-4 °F ... +230 °F)	-20 ... +80 °C (-4 ... +176 °F) ¹⁾	-20 ... +50 °C (-4 ... +122 °F) ²⁾	-45 ... +60 °C (-49 ... +140 °F)	-40 ... +60 °C (-40 ... +140 °F)
Power requirements	19 V ... 36 V DC, < 100 mA	20 ... 30 V DC, 18 mA	100/115/200/230 V AC ± 10 % 50/60Hz, 15 VA	Switch 18 ... 48 V AC/DC or 60 ... 135 V AC/DC	115 or 230 V AC ± 10 % 50/60 Hz, 7 VA
Approvals	CE, PROFIBUS DP and PROFIBUS PA conform, Ex protection to ATEX 1G or 1D	CE, C-TICK, CSA/FM Class II, Div. 1, Group E, F, G optional, ATEX II 2D, 2G, 3D optional, GOST-R	CSA _{US/C} , CE, C-TICK	CSA _{US/C} , CE, C-TICK	CSA _{US/C} , CE, C-TICK

¹⁾ Extended temperature model -40 ... +125 °C (-40 ... +257 °F) available (CE version)

²⁾ Probes available for -40 ... +260 °C (-40 ... +500 °F)

Process Protection

Acoustic sensors for pump monitoring

SITRANS DA400

Overview



The SITRANS DA400 acoustic diagnostic unit acoustically measures the structure-borne noise

- In the version for pump monitoring; on oscillating displacement pumps
- In the version for material flow monitoring; on pipes, conveying equipment or channels.

It comprises an electric diagnostic unit and up to four acoustic sensors.

Benefits

Benefits when pump monitoring

- Increased availability of the system through:
 - Advanced maintenance planning thanks to early recognition of defective components
 - Reduced downtimes (no fault locating necessary)
 - Increased maintenance intervals
 - Greater pump reliability
- Prevention of expensive consequential damage
- Increased safety of critical applications
- Early recognition of a reduction in power
- Increased productivity

Benefits when material flow monitoring

- Detection of insufficient or excessive inflow of material in a liquid or gas flow
- Detection of blockages or clogging
- Reduction of down times
- Increased product quality
- Increased availability
- Guaranteed operational safety
- Increased productivity

Application

In the version for pump monitoring, the SITRANS DA400 allows continuous, simultaneous and independent monitoring of up to four flow control valves in a pump for leaks. In addition, another four inputs are available for monitoring standard signals (e.g. diaphragm and temperature monitoring). This means that the condition of an oscillating displacement pump is monitored in every phase of its operation.

The SITRANS DA400 is used in all industries where an oscillating displacement pump is used.

The version for material flow monitoring monitors the material flow in liquids or gases that is usually as a result of impact or friction, e.g. against the pipe or channel wall.

If the acoustic diagnostic unit is used in potentially explosive areas, the sensors as well as the acoustic diagnostic unit can be installed in the Ex-zone.

If using the unit in potentially explosive areas, you have two options:

- Operation of the sensors over the safety barriers or
- Operation of the sensors over the SITRANS DA400 with explosion protection

Function

Product features

Continuous and independent status monitoring:

- Of the flow control valves, for leaks
- Of the membranes, for material fatigue
- Of the temperature loading of the hydraulic oil
- Of flowing bulk solids in pipes, conveying equipment or channels

Communication of the status to superordinate control systems:

- Via digital outputs
- Digitally, via PROFIBUS DP or PROFIBUS PA

Simple to operate and parameterize:

- Locally, via digital display and keys
- PROFIBUS DP and PROFIBUS PA

Mode of operation

Principle of measurement

Leaks in the flow control valves of oscillating displacement pumps are flows in which cavitation occurs. This results in sound waves that are transmitted to the valve housing, where they are recorded by the structure-borne sound sensor in the SITRANS DA400 on the outside.

The SITRANS DA400 utilizes the fact that with both an open valve and a closed intact valve, no cavitation occurs and the measured sound level thus corresponds to the operating noise of the pump. By contrast, with a closed defective valve cavitation does occur, which can be identified by a period increase in the sound level (see figures). The measured value from the SITRANS DA400 corresponds exactly to this increase in the sound level.

In the version for material flow monitoring, SITRANS DA400 continuously detects high-frequency acoustic oscillations by means of structure-born noise sensors.

Process Protection

Acoustic sensors for pump monitoring

SITRANS DA400

These oscillations are created by:

- Friction and impact of bulk solids in:
 - pipes, raceways or channels
 - chutes
 - conveyors
- Friction and impact of mechanical parts
- Bursting of bubbles
- Cavitation
- Turbulence in gas and liquid flows

The following shows an example of signal levels at an oscillating displacement pump

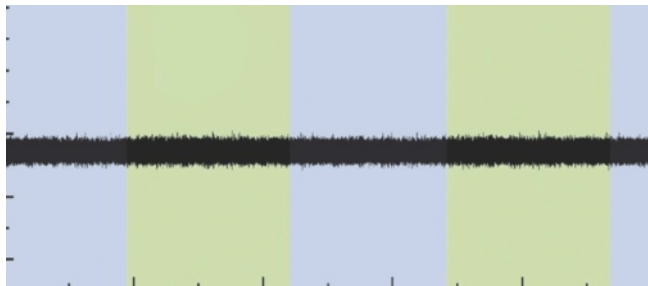

Signal from structure-borne sound sensor with intact valve

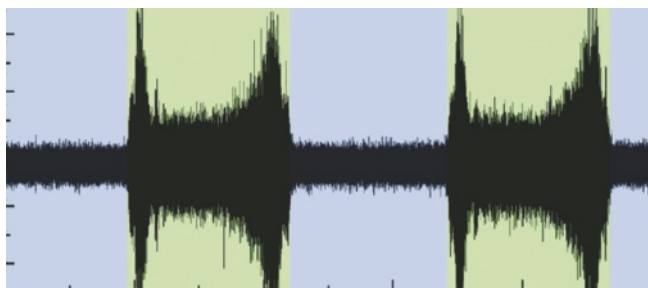

Signal from structure-borne sound sensor with defective valve

Sensor operation

The structure-borne sound sensor works on the piezoelectric principle. The structure-borne sound is injected into the sensor via the sensor base (mounting surface) and inside it is converted into an electrical voltage by a piezo-ceramic element. This is amplified in the sensor and transmitted via the cable.

The sensor frequency range lies in the ultrasonic range (> 20 kHz). The sensor is non-directional, i.e. the angle at which the sound wave impacts on the sensor base is not important.

Mode of operation of the safety barrier

The safety barrier comprises intrinsically-safe circuits. These circuits serve to operate intrinsically-safe components such as sensors and to isolate safety from the non-hazardous area with the SITRANS DA400 diagnostic unit.

Technical specifications

SITRANS DA400	Without Ex protection	With Ex protection
Input		
Acoustic channels		4
• Cycle time		10 ms
Only for connection to intrinsically safe sensors with:		
• Max. voltage U_o	-	≤ 5.5 V
• Max. current I_o	-	≤ 70 mA
• Max. power P_o	-	≤ 100 mW
• Internal capacitance C_i	-	≤ 1.2 μ F
• Internal inductance L_i	-	Negligible
Universal inputs		4
• Cycle time		80 ms
• Low pass filter time		1 s
Universal analog current input		
• Load	< 105 Ω	< 12 Ω
• Resolution		0.1 %
• Accuracy		0.5 %
• Fault signal		> 21 mA or < 3.6 mA (at 4 ... 20 mA)
• Alarm monitoring hysteresis		0.5 %
• Static destruction limit	40 mA, 4 V	-
For connection with approved intrinsically safe circuits with:		
• Max. supply voltage U_i	-	≤ 30 V
• Max. short-circuit current I_i	-	≤ 100 mA
• Max. power P_{oi}	-	≤ 1 W
• Internal capacitance C_i	-	≤ 11 nF
• Internal inductance L_i	-	≤ 70 μ H
Universal input 24 V digital signal		
• Input resistance		> 19 k Ω
• Signal level Low		< 4.5 V or open
• Signal level High		> 7 V
• Hysteresis		> 1 V
• Static destruction limit	± 40 V	-
For connection with approved intrinsically safe circuits with:		
• Max. supply voltage U_i	-	≤ 30 V
• Max. short-circuit current I_i	-	≤ 100 mA
• Max. power P_{oi}	-	≤ 1 W
• Internal capacitance C_i	-	≤ 11 nF
• Internal inductance L_i	-	≤ 70 μ H

Process Protection

Acoustic sensors for pump monitoring

SITRANS DA400

SITRANS DA400	Without Ex protection	With Ex protection
Universal input closing contact		
For connection to closing contact with the maximum values:		
• Max. voltage U_o	-	≤ 10 V
• Max. current I_o	-	≤ 1 mA
• Max. power P_o	-	≤ 5 mW
• Internal capacitance C_i	-	≤ 11 nF
• Internal inductance L_i	-	≤ 70 μH
8.2 V source for NAMUR signal (DIN EN 60947-5-6)		
• Open circuit voltage	8.2 V ± 0.3 V, short-circuit proof	-
• Input resistance	< 950 Ω	-
• Static destruction limit for incorrect wiring	+20 V/-10 V	-
Output		
Digital outputs	6	6 (applicable for NAMUR switch hardener)
• Semiconductor relay	Individually isolated, short circuit-proof	-
• Switching voltage	24 V AC/ 36 V DC, any polarity	-
• Destruction limit	35 V AC, 50 V DC	-
• Max. switching current	100 mA	-
• Signal status Low (no response)	-	≤ 1.2 mA (source to DIN 19234)
• Signal status High (response)	-	≥ 2.1 mA (source to DIN 19234)
For connection with an intrinsically safe switching amplifier to DIN 19234 with:		
• Max. supply voltage U_i	-	≤ 15.5 V
• Max. short-circuit current I_i	-	≤ 25 mA
• Max. power P_{oi}	-	≤ 64 mW
• Internal capacitance C_i	-	≤ 5.2 nF
• Internal inductance L_i	-	Negligible
Conditions of use		
Installation conditions	Vertical wall mounting, cables fed in from below	
Climatic class	Class 4K4 according to EN 60721-3-4	
Mounting location	-	Zone 1 or zone 2
Permissible ambient temperature	-20 ... +60 °C (-4 ... +140 °F)	-
• Temperature class T5 – T1		-20 ... +60 °C (-4 ... +140 °F)
• Temperature class T6		-20 ... +50 °C (-4 ... +122 °F)
Mechanical load	Class 4M3 according to EN 60721-3-4	
Degree of protection to EN 60529	IP65	

SITRANS DA400	Without Ex protection	With Ex protection
Electromagnetic Compatibility		
• Emitted interference and interference immunity	To EN 61326 and NAMUR NE 21	
Usage limits for water		
• Delivery side	≥ 10 bar a	
• Number of strokes	Min. 4 min ⁻¹ , max. 10 ... 500 min ⁻¹	
Design		
Weight (without options)	Approx. 2.5 kg	
Dimensions (W x H x D) in mm (inch)	172 x 320 x 80 (6.8 x 12.6 x 3.2)	
Enclosure material	Macrolon (polycarbonate +20 % glass fiber)	Makrolon (Polycarbonate +20 % glass fibers), surface attenuated with CrNi layer and painted
Electrical connection via screw terminals		<ul style="list-style-type: none"> • Rigid 2.5 mm (0.984 inch) • Flexible 1.5 mm (0.59 inch) • Flexible with connector sleeves 1.5 mm (0.59 inch)
Cable inlet via plastic cable joints		<ul style="list-style-type: none"> • 2 x Pg 13.5 • 5 x Pg 11
Power supply		
Rated voltage	24 V DC	16 V DC
Operating range	19 ... 36 V DC	15 ... 17 V DC
Current consumption	< 100 mA	< 40 mA
For connection with approved intrinsically safe circuits with:		
• Max. supply voltage U_i	-	≤ 17.4 V
• Max. short-circuit current I_i	-	≤ 191 mA
• Max. power P_{oi}	-	≤ 1.35 W
• Internal capacitance C_i	-	≤ 33 nF
• Internal inductance L_i	-	≤ 28 μH
Certificates and approvals		
Explosion protection to EN 50014, EN 50020 and EN 50021		
Intrinsic safety "i"	-	TÜV (German Technical Inspectorate) 06 ATEX 2952
Marking	-	II 2(1) G EEx is [ia] IIC T6
Communication		
PROFIBUS DP	RS 485, switchable terminating resistor	
Protocol	Cyclic with Master C1 and acyclic with Master C2	
Power supply	-	Bus-supplied
Bus voltage	-	9 ... 24 V
Current consumption	-	10.5 mA ± 10 %

Process Protection

Acoustic sensors for pump monitoring

SITRANS DA400

SITRANS DA400	Without Ex protection	With Ex protection
Bus connection with FISCO supply unit, ia/ib group IIC or IIB	-	Yes
Layer 1 and 2 from PROFIBUS PA, transfer technology from IEC 1158-2	-	
• C2 connections	-	4 connections are supported in master class 2
• Device profile	-	PROFIBUS PA Profil V3.0 Rev. 1, Class B
• Device address	-	1 ... 126 (126 factory-set)
PC parameterization software	SIMATIC PDM (not included in the scope of delivery)	

Sensor for SITRANS DA400

Setup	<ul style="list-style-type: none"> • Piezoceramic sensor with pre-amplifier • Encapsulated electronics • 4-wire cable with anti-kink sleeve
Conditions of use	
Permissible Ambient Temperature	-40 ... +110 °C (-40 ... +230 °F)
Degree of protection to EN 60529	IP66/IP68
Mechanical load	Class 4M7 according to EN 60721-3-4
Climatic class	Class 4K4 according to EN 60721-3-4
Design	
Housing material	Stainless steel 1.4571 (316Ti SST)
Cable	Ends with wire protectors and cable shoe for connection to the SITRANS DA400
Weight	125 g (0.276 lb)
Mounting location	Zone 0/1 or zone 20/21/22
Dimensions (W x H x D) in mm (inch)	26 x 29 x 40 (1.02 x 1.14 x 1.57)
Power supply	Power fed from device
Certificates and approvals	
Explosion protection	
Intrinsic safety "i"	TÜV 2005 ATEX 2876 X
Marking	II 1 G EEx ia IIC T6/T5/T4 or II 1 D EEx ia D 20/21/22 T160
Permissible ambient temperature	
• Category 1G	-20 ... +60 °C (-4 ... +140 °F) - Temperature class T4, T5 - Temperature class T6
• Category 2G	-40 ... +110 °C (-40 ... +230 °F) - Temperature class T4 - Temperature class T5 - Temperature class T6
• Category 1D or 2D	-20 ... +65 °C (-4 ... +149 °F) - Temperature class T160

Ex barriers for sensors	
Application area	For the intrinsically safe supply of the acoustic sensors in zone 1; the safety barriers must be installed between the SITRANS DA400 acoustic diagnostic unit and the sensor if only the sensors are being operated in the Ex zone.
Input	A maximum of two sensors can be connected.
Conditions of use	
Degree of protection to EN 60529	IP20
Permissible Ambient Temperature	-20 ... +60 °C (-4 ... +140 °F)
Design	
Weight	115 g (0.254 lb)
Housing material	Plastic, polyamide
Type of installation	Installation on mounting rail NS 32 or NS 35/7.5. The acoustic diagnostic unit SITRANS DA400 and the safety barrier must be operated outside the Ex zone.
Dimensions (W x H x D) in mm (inch)	68 x 77 x 42 (2.68 x 3.03 x 1.65)
Certificates and Approvals	
Explosion protection	
Intrinsic safety "i"	TÜV 05 ATEX 2917 X
Marking	II (2) G [EEx ib] IIC

6

Selection and Ordering data	Order-No.
Acoustic diagnostics unit SITRANS DA400 with local programming and display	7 M J 2 4 0 0 - ■ ■ A 0 ■
Communication	
• PROFIBUS DP	1 A
• PROFIBUS PA	2 B
Explosion protection	
• without	A
• with EEx ia/ib to ATEX ¹⁾	B
Application software	
for continuous condition monitoring of positive displacement pumps	1
for material flow monitoring in pipes, raceways and conveyors	2
Acoustic sensors for diagnostics unit SITRANS DA400	7 M J 2 0 0 0 - 1 ■ ■ 0 0
Explosion protection	
• without	A
• with EEx ia to ATEX	B
Cable	
(incl. pin and allen screw M6)	
20 m	B
40 m	C
100 m	F
Safety barriers for sensors	7MJ2010-1AA
for rail mounting NS 32 and NS35/7.5 in non hazardous areas Explosion-protected output circuit EEx ib	

¹⁾ Not in combination with trigger sensor.

Process Protection

Acoustic sensors for pump monitoring

SITRANS DA400

Dimensional drawings

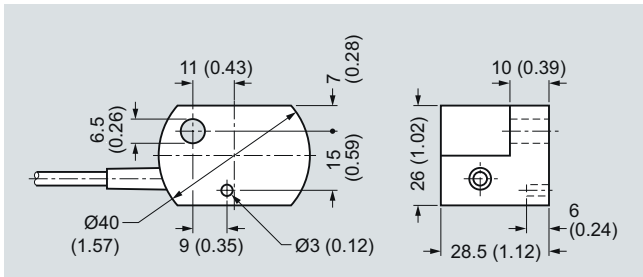

Sensor for SITRANS DA400, dimensions in mm (inch)

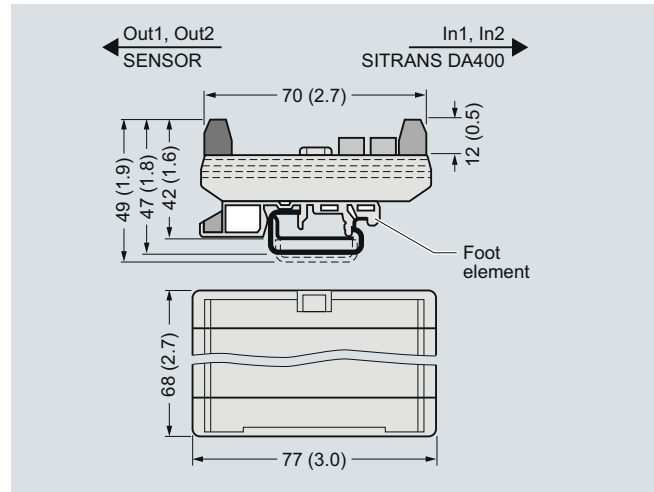

Safety barrier for SITRANS DA400, dimensions in mm (inch)

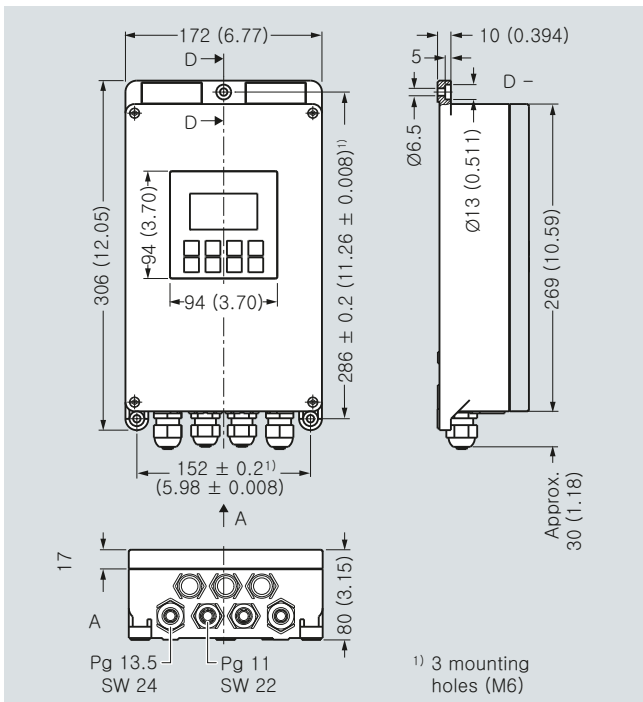

SITRANS DA400, dimensions in mm (inch)

Schematics

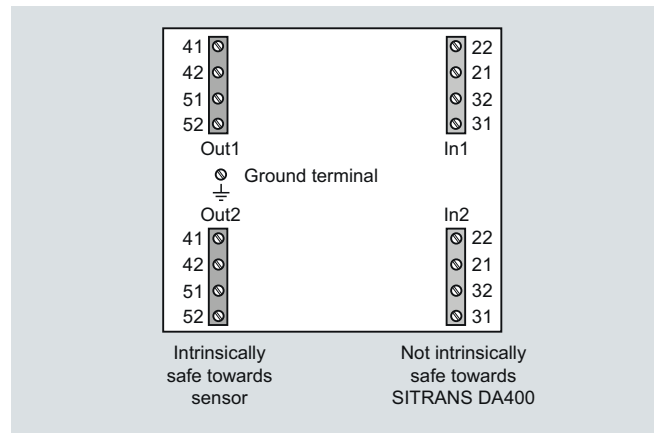

Safety barrier for SITRANS DA400, terminal assignment

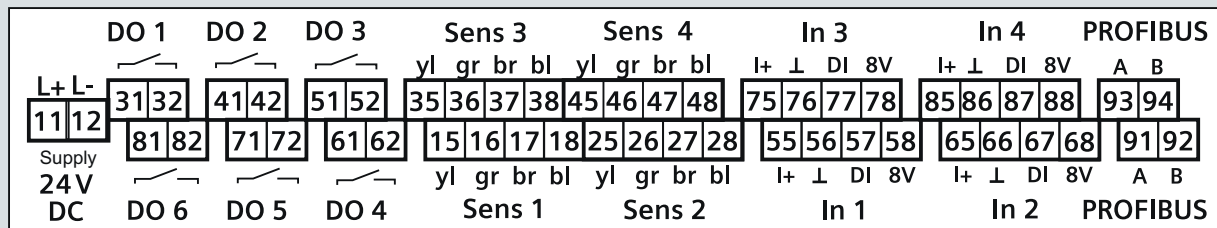

- L+/L- Power supply (Any polarity with PROFIBUS PA)
- DO Digital output
- Sens Sensor
- In Input
- yl yellow
- gr green
- br brown
- bl black
- I+ Analog current input +
- ⊥ Ground
- DI Digital input
- A Signal A (green) with PROFIBUS DP, any with PROFIBUS PA
- B Signal B (red) with PROFIBUS DP, any with PROFIBUS PA

SITRANS DA400, terminal assignment

Process Protection

Acoustic sensors for material flow monitoring

SITRANS AS100

Overview



SITRANS AS100 is an acoustic sensor used for solids flow detection.

Benefits

- Non-invasive
- Screw in, bolt on, weld, or bond in place
- Analog output
- High and low sensitivity range of operation

Design

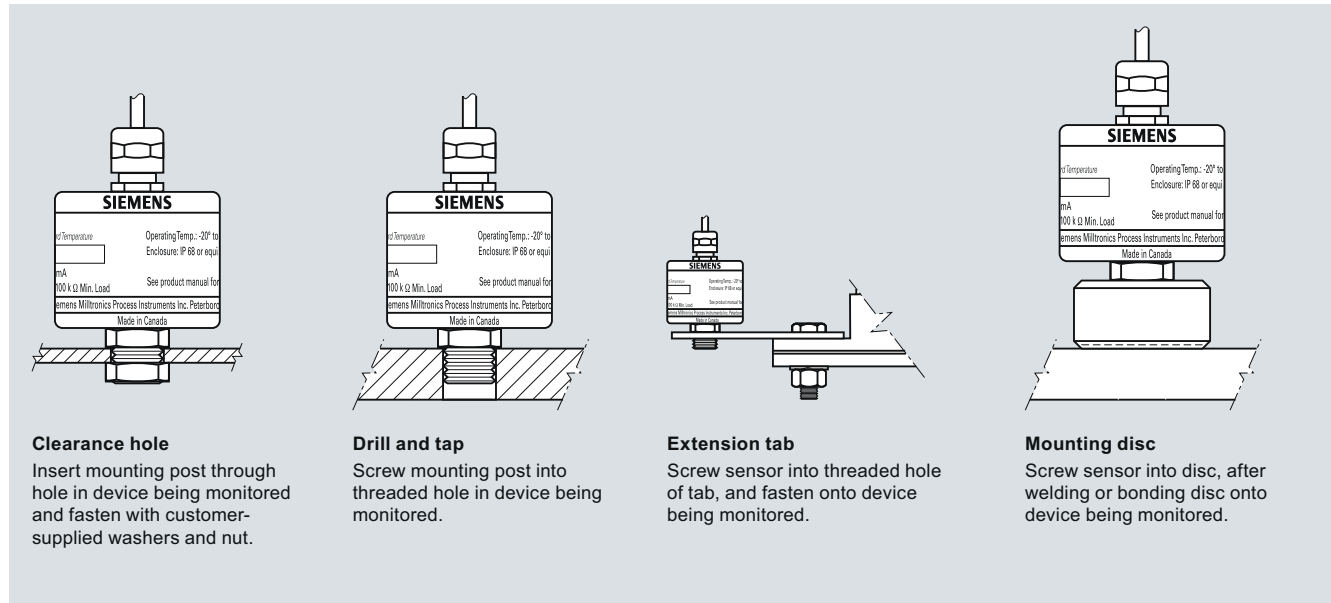

Clearance hole

Insert mounting post through hole in device being monitored and fasten with customer-supplied washers and nut.

Drill and tap

Screw mounting post into threaded hole in device being monitored.

Extension tab

Screw sensor into threaded hole of tab, and fasten onto device being monitored.

Mounting disc

Screw sensor into disc, after welding or bonding disc onto device being monitored.

SITRANS AS100 mounting

Application

SITRANS AS100 detects changes in high frequency sound waves from equipment and materials in motion. It detects and reacts instantly to changes in solids flow to warn of blockages, product absence, or equipment failure such as burst filter bags. This allows an operator to take early preventative action and avoid costly damage.

Common applications include pellets, powders and most bulk solids in pipes, chutes, vibratory feeders, pneumatic conveyors or aerated gravity flow systems.

Operating with a SITRANS CU02 control unit, the system detects conditions of high flow, low flow or no flow. It can be added to a control loop via a 4 to 20 mA output. Two relays are fully programmable and independent of each other and can be used to operate an alarm or control device.

With no moving parts and a type 304 or 303 stainless steel enclosure sealed against dust and moisture, this non-invasive unit requires little or no maintenance. With a dual operating range, the sensor offers an exceptionally wide range of application capabilities.

- Key applications: pipes, chutes, vibratory feeders, aerated gravity flow systems, burst filter bag detection

Process Protection

Acoustic sensors for material flow monitoring

SITRANS AS100

Technical specifications		Selection and Ordering data	Order No.
Mode of Operation		SITRANS AS100 Acoustic Sensor	7MH7560-
Operating principle	Acoustic sensing of high frequency emissions caused by impact or friction	An acoustic sensor used for solids flow detection.	0
Typical application	<ul style="list-style-type: none"> • Detects burst filter bags in dust collection systems • Detects material being conveyed in pneumatic conveyor lines • Route confirmation in chute work 	Sensor	1
		Standard temperature range [-20 ... +80 °C (-4 ... +176 °F)] ¹⁾	3
		Extended temperature range [-40 ... +125 °C (-40 ... +257 °F)] ²⁾	4
		Extended temperature range [-30 ... +120 °C (-22 ... +248 °F)] ³⁾	
		Cable Length	A
		4 meters (13.12 ft)	
		Sensor Mounting	A
		None	B
		Mounting disk	C
		Mounting tab	
Model		Approvals	1
Standard	Standard operating temperature range	CE, C-TICK	3
Extended	Extended operating temperature range	CSA/FM Class II Div.1, Group E, F and G (includes ½" NPT female fitting)	4
		CSA Class II, Div. 1, Group E, F and G (includes ½" NPT female fitting)	5
		CE, C-TICK, FM/CSA Class II, Div. 1, Group E, F and G, ATEX II 3D (includes M20 female fitting)	6
		ATEX II 2G/D, c/w cable gland ⁴⁾	
Operation			
Relative sensitivity	0.5 %/°C of reading, average over the operating range		
Outputs	Analog, 0.08 ... 10 V DC nominal, 100 kΩ minimum load impedance		
Rated operating conditions			
Amb. temperature for enclosure			
• Standard	-20 ... +80 °C (-4 ... +176 °F)		
• Extended	<ul style="list-style-type: none"> • -40 ... +125 °C (-40 ... +257 °F) (CE only) • -30 ... +120 °C (-22 ... +248 °F) option 		
Design			
Weight	0.4 kg (1 lb)		
Enclosure	Enclosure: 304 (1.4301) stainless steel [303 stainless steel (1.4305) on Class II version]		
Degree of protection	IP68 (waterproof)		
Cable			
• Standard	4 m (13 ft) cable, PVC jacketed, 3 twisted pairs, 24 AWG (0.25 mm ²), shielded		
• Extended	4 m (13 ft) cable, thermoplastic elastomer jacketed, 6 conductor, 24 AWG (0.25 mm ²) conductor, shielded		
Power supply	20 ... 30 V DC, 18 mA (typical)		
Certificates and approvals	CE, C-TICK CSA/FM Class II, Div. 1, Group E, F and G (optional), ATEX II 2G/2D (optional), ATEX II 3D (optional), GOST-R		
		Selection and Ordering data	Order code
		Further designs	
		Please add "-Z" to Order No. and specify Order code(s).	
		Manufacturer's test certificate: According to EN 10204-2.2	C11
		Acrylic coated, stainless steel tag [12 x 45 mm (0.5 x 1.75 inch)]: Measuring-point number/identification (max. 16 characters), specify in plain text	Y17
		Operating Instructions	Order No.
		English	7ML1998-5DM02
		German	7ML1998-5DM32
		French	7ML1998-5DM12
		Spanish	7ML1998-5DM21
		Note: The operating instructions should be ordered as a separate item on the order. This device is shipped with the Siemens Milltronics manual CD containing ATEX Quick Starts and operating instructions.	
		Spare Parts	
		Mounting tab	7MH7723-1AA
		Mounting disk	7MH7723-1AB
		½" NPT adapter kit for standard temperature range sensor, not Class II approved	7MH7723-1BW
		M20 adapter kit for standard temperature range sensor, not Class II or ATEX approved	7MH7723-1BV
		½" NPT adapter kit for extended temperature range sensor, not Class II approved Note: Adapter kits are not CSA Class II approved	7MH7723-1BX

Process Protection

Acoustic sensors for material flow monitoring

SITRANS AS100

Dimensional drawings

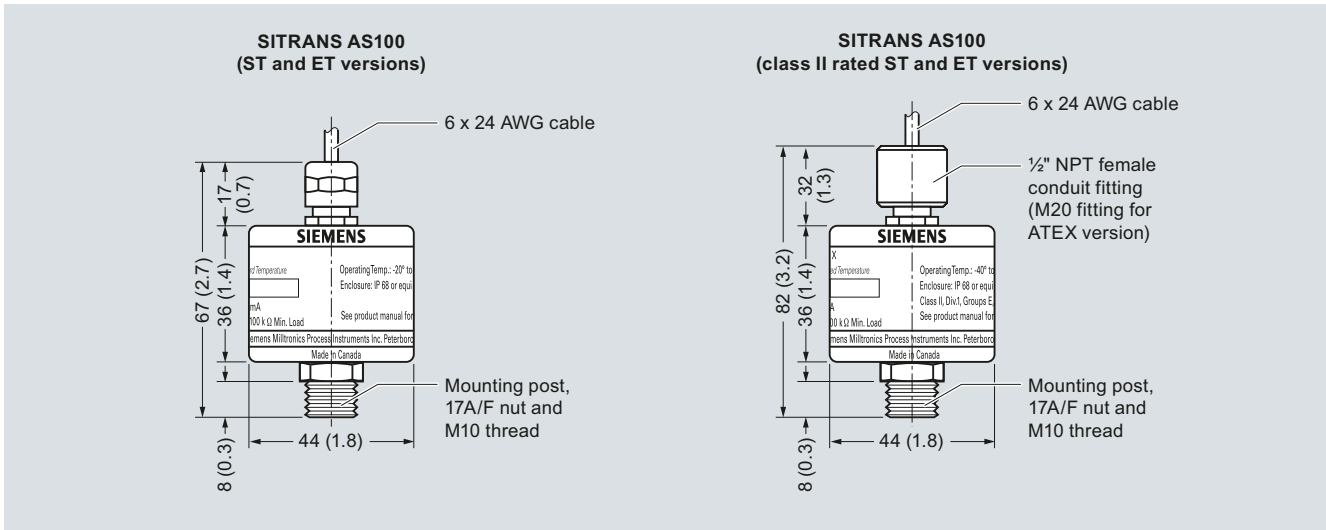

SITRANS AS100, dimensions in mm (inch)

Accessories

Extension Tab - Bolt on (304 stainless steel)

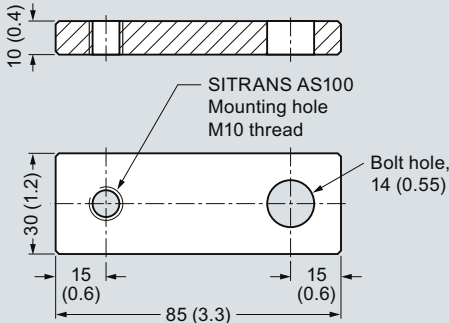

Mounting Disc - Bonded or Welded (304 stainless steel)

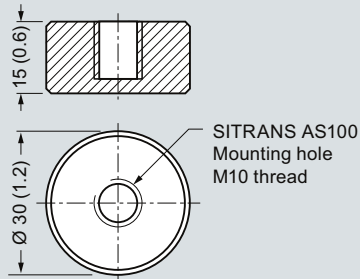

SITRANS AS100 accessories, dimensions in mm (inch)

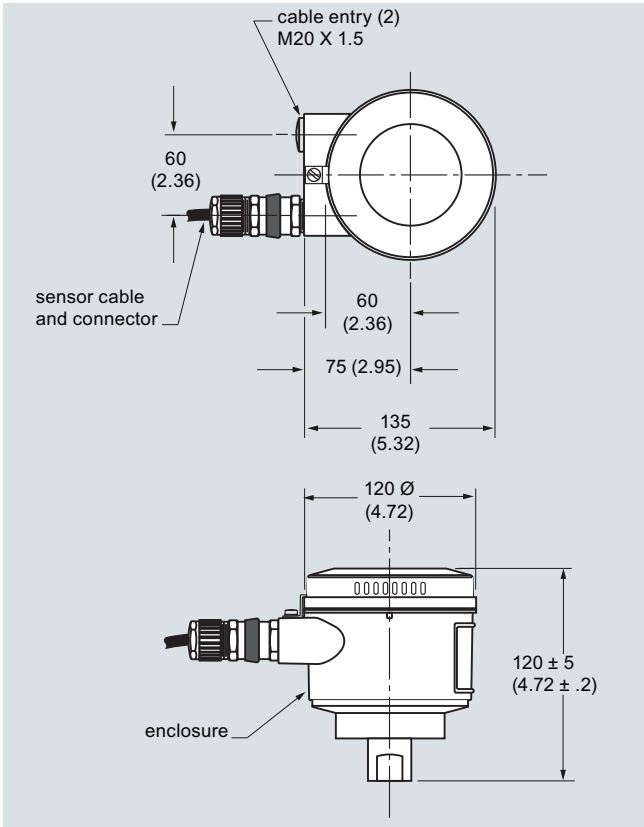

SITRANS AS100 (2D, 2G, XP version), dimensions in mm (inch)

Schematics

Standard temperature range

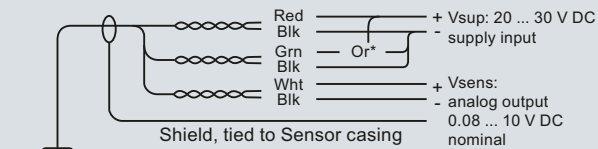

* Sensor range selection
 High sensitivity range = red and green to Vsup+
 Low sensitivity range = red to Vsup+, green to Vsup-

Extended temperature range

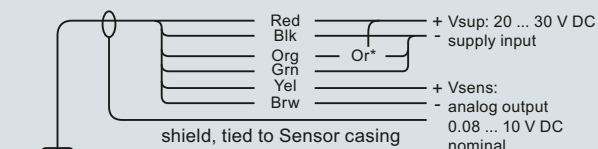

* Sensor range selection
 High sensitivity range = red and orange to Vsup+
 Low sensitivity range = red to Vsup+, orange to Vsup-

Interconnection

The longer the cable, the more susceptible it is to noise and earth loops. It is therefore recommended to use cable with heavy gauge conductors and good RF/electrical shielding (copper braid rather than drain and foil). A proper junction box close to the sensor is an ideal location not only to extend the cable but also to configure the wiring for high or low sensitivity range operation.

The following table provides a guideline for suitable wire gauges where distances are considerable.

Max. distance between sensor and supply
 (24 V or Control Unit).

AWG	Wire size		Distance	
	mm	mm ²	meters	feet
24	7 x 0.20	0.25	500	1 600
22	7 x 0.25	0.35	800	2 600
20	10 x 0.25	0.5	1 200	3 900

SITRANS AS100 connections

Process Protection

Acoustic sensors for material flow monitoring

SITRANS CU02

Overview



SITRANS CU02 is an alarm control unit, for use with SITRANS AS100 acoustic sensor, that provides reliable continuous protection for bulk solids flow.

Benefits

- 4 to 20 mA output
- Two programmable relays
- Adjustable independent time delay for each relay
- Adjustable start-up time delay
- DIN rail mounting provides easy installation
- Built-in password protection to parameters

Application

SITRANS CU02 receives a 0 to 10 V DC input signal from the SITRANS AS100 sensor, providing relay and analog outputs for interface into a process.

- Key applications: with SITRANS AS100 for bulk solids flow

Function

The system can be readily configured for set points indicating such conditions as high flow, low flow or no flow. Alternatively, it can be added to a control loop via a 4 to 20 mA isolated output for trend monitoring proportional to the signal from the sensor.

Two relays are fully programmable and independent of each other and can be used to operate an alarm or control device. Alarming may be provided above or below a setpoint or within a band. Readings are also displayed locally by the SITRANS CU02 on its LCD.

The SITRANS CU02 may be mounted up to 500 m (1 500 ft) from the sensor.

Technical specifications

Mode of operation	
Measuring principle	Controller for acoustic sensing (SITRANS AS100)
Typical application	Connects to SITRANS AS100 to detect burst filter bag
Input	
	0 ... 10 V DC, from sensor
Output	
Output signal	4 ... 20 mA isolated output, 2 Form C relays - latching or non-latching – 5 A at 250 V AC non-inductive
Sensor excitation	26 V DC
Max. load	750 Ω
Rated operating conditions	
Installation conditions	
• Location	Indoor
Ambient conditions	
• Ambient temperature for enclosure	-20 ... +50 °C (-4 ... +122 °F)
• Relative humidity	80 % for temperatures up to 50 °C (122 °F)
• Degree of protection	IP20
• Installation category	II
• Pollution degree	2
Design	
Weight	550 g (18 oz)
Dimensions (W x H x D)	55 x 75 x 110 mm (2.2 x 3 x 4.4 inch)
Material enclosure	Polycarbonate
Mounting	DIN Rail (DIN 46277 or DIN EN 50022), or wall mount, up to 500 m (1 500 ft) from sensor
Cable	2 twisted pair, 24 AWG (22 mm ²), shielded. Mount up to 500 m (1 500 ft) from sensor
Display	
	Liquid crystal, three digits, 9 mm (0.35 inch), high and multi-segment graphic symbols for operation status
Power supply	
Supply voltage	100, 115, 200, 230 V AC ± 15 %, 50/60 Hz, factory set
Power consumption	Max. 10 VA
Approvals	
	CSA _{US/C} , CE, C-TICK, GOST-R

Process Protection

Acoustic sensors for material flow monitoring

SITRANS CU02

Selection and Ordering data	Order No.	Selection and Ordering data	Order code
SITRANS CU02 Control Unit Alarm control unit for use with SITRANS AS100 acoustic sensor to provide reliable continuous protection for bulk solid flow	7MH7562 - 	Further designs Please add "-Z" to Order No. and specify Order code(s). Manufacturer's test certificate: According to EN 10204-2.2 Acrylic coated, stainless steel tag [38 x 51 mm (1.5 x 2 inch)]: Measuring-point number/identification (max. 16 characters), specify in plain text	C11 Y18
Power Supply 100 V AC 115 V AC 200 V AC 230 V AC		Operating Instructions English French German Note: The operating instructions should be ordered as a separate item on the order. This device is shipped with the Siemens Milltronics manual CD containing the complete operating instructions library.	Order No. 7ML1998-5DN01 7ML1998-5DN11 7ML1998-5DN31
Enclosure Standard DIN Rail			
Approvals CSA _{US/IC} , CE, C-TICK			

Dimensional drawings

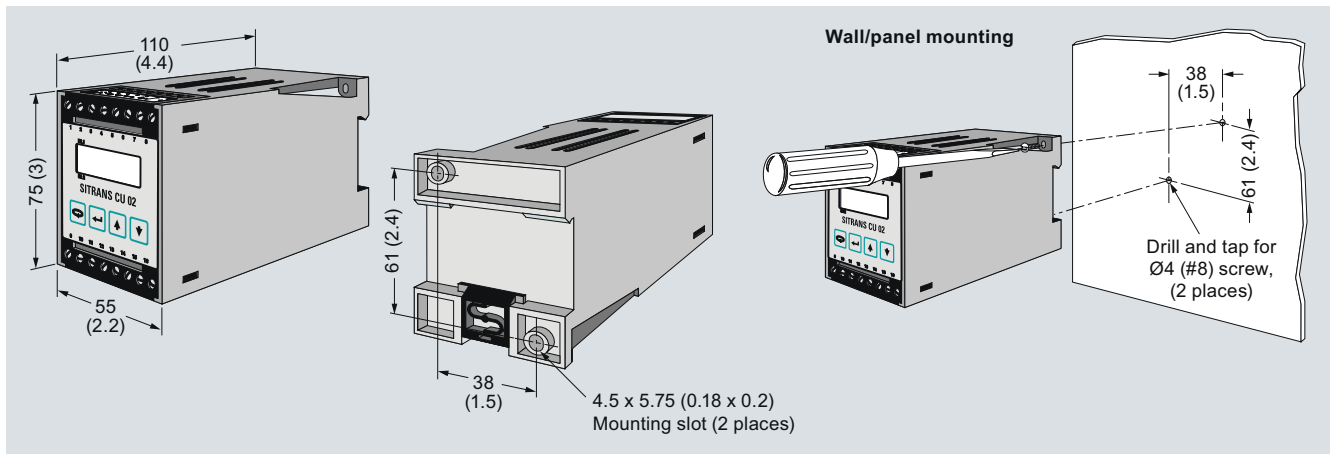

SITRANS CU02, dimensions in mm (inch)

Process Protection

Acoustic sensors for material flow monitoring

SITRANS CU02

Schematics

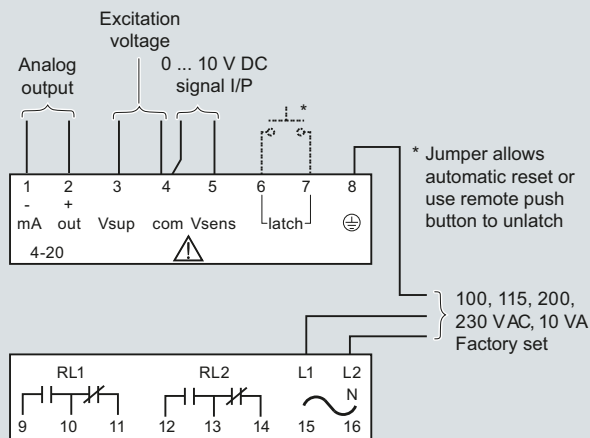

Standard temperature version

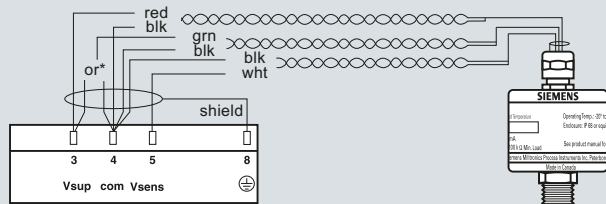

* Sensor range selection

High sensitivity range = green to 'Vsups'
Low sensitivity range = green to 'com'

Extended temperature version

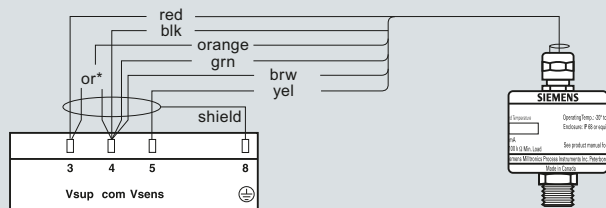

* Sensor range selection

High sensitivity range = orange to 'Vsups'
Low sensitivity range = orange to 'com'

Mounting

Installation shall only be performed by qualified personnel and in accordance with local governing regulations.

This product is susceptible to electrostatic shock. Follow proper grounding procedures.

Interconnection

All field wiring must have insulation suitable for at least 250 V. Relay contact terminals are for use with equipment having no accessible live parts and wiring having insulation suitable for at least 250 V.

The maximum allowable working voltage between adjacent relay contacts shall be 250 V. If sensor case is grounded, do not connect shield of cable to SITRANS CU02 ground terminal.

SITRANS CU02 connections

Overview



MFA 4p motion failure alarm controller is a highly sensitive single setpoint motion sensor system, used with Milltronics MSP and XPP probes.

Application

The MFA 4p detects changes in the motion and speed of rotating, reciprocating or conveying equipment. It warns of equipment malfunction and signals through contacts to shut down machinery in case of a slowdown or failure. Its reliability makes it a cost-effective way to protect valuable process equipment.

The single setpoint system suits most industrial applications. This versatile unit can be used on tail pulley shafts, driven pulleys, motor shaft sensing, belt or drag conveyors, screw conveyor flights, bucket elevators, fans and pumps.

A special feature is the adjustable 0 to 60 second time delay, allowing the monitored device to accelerate to normal running speed before monitoring begins. A wide range of probes are available to suit specific needs, including high temperatures, corrosive, and Class I, II and III installations. The CE approval allows the MFA 4p to consistently meet the needs of the mining aggregate, cement and other primary and secondary industries.

- Key Applications: tail pulleys, motor shaft sensing, screw conveyor flights, bucket elevators

Benefits

- Up to 100 mm (4 inch) gap between target and probe
- Switch selectable overspeed or underspeed detection
- Setpoint adjustment 0.15 to 3 000 PPM (pulses/minute)
- Adjustable start-up time delay
- Visual indication of probe operation and relay status
- General purpose, suitable for majority of industrial applications; rugged probe designs provide unmatched reliability

Design

Mounting

Mounting for Milltronics MSP-12, MSP-3, XPP-5

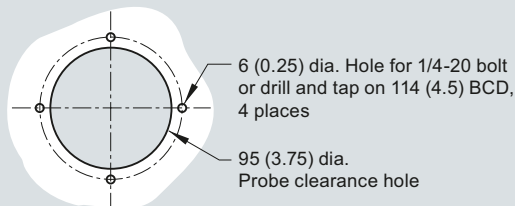

Note: For MSP-1 29 mm (1.125 inch) clearance hole required.

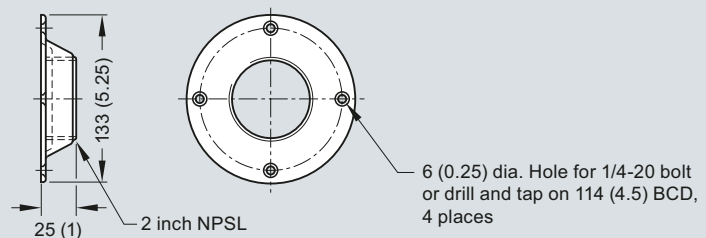

Note: Mounting flange supplied with probe.

Mounting for Milltronics MSP-9

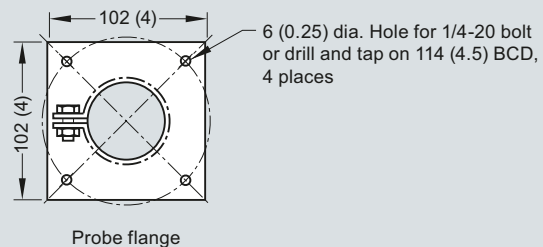
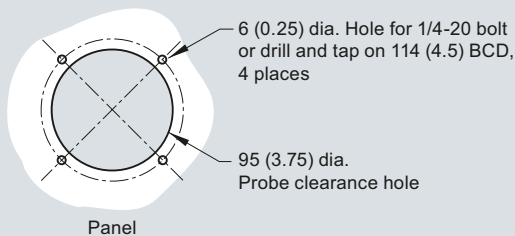

MSP-1, MSP-12, MSP-3, MSP-9, XPP-5 mounting, dimensions in mm (inch)

Process Protection

Motion sensors

Milltronics MFA 4p

Probes

Standard Milltronics MSP-12

- Heavy-duty general purpose motion probe
- Long lasting phenolic body with internal amplifier
- Convenient mounting flange and locknut for fast installation and setup
- Temperature rating: -40 ... +60 °C (-40 ... +140 °F)
- Enclosure rating: Type/NEMA 4X, 6, IP67



High temperature Milltronics MSP-3

- Heavy-duty, high temperature aluminum probe designed to withstand operating temperatures to 260 °C (500 °F)
- Cast aluminum probe with convenient mounting flange and locknut
- 1.5 m (5 ft) of high temperature PTFE cable provided. Up to 30 m (100 ft) may be used.
- Amplifier remote mounted in enclosure 140 x 140 x 100 mm (5.5 x 5.5 x 4 inch), available in cast aluminum (½" NPT conduit entry), painted steel (Type/NEMA 4, IP65 rating), or stainless steel (Type/NEMA 4X, IP65 rating)
- Amplifier temperature rating -40 ... +60 °C (-40 ... +140 °F)
- Enclosure rating: Type/NEMA 4X, 6, IP67



Stainless high temperature Milltronics MSP-9

- Heavy-duty, high temperature 304 stainless steel probe
- Special construction allows operation of probe in environment up to 260 °C (500 °F)
- 1.5 m (5 ft) special high temperature PTFE cable provided. Up to 30 m (100 ft) may be used.
- Amplifier remote mounted in enclosure 140 x 140 x 100 mm (5.5 x 5.5 x 4 inch), available in cast aluminum (½" NPT conduit entry), painted steel (Type/NEMA 4, IP65 rating), or stainless steel (Type/NEMA 4X, IP65 rating)
- Enclosure rating: Type/NEMA 4X, 6, IP67
- Amplifier temperature rating -40 ... +60 °C (-40 ... +140 °F)



Miniature Milltronics MSP-1

- Miniature probe for installations with limited mounting space
- CPVC probe body complete with locknuts
- 1.8 m (6 ft) cable provided. Up to 30 m (100 ft) may be used.
- Amplifier remote mounted in enclosure 140 x 140 x 100 mm (5.5 x 5.5 x 4 inch), available in cast aluminum (½" NPT conduit entry), painted steel (Type/NEMA 4, IP65 rating), or stainless steel (Type/NEMA 4X, IP65 rating)
- Enclosure rating: Type/NEMA 4X, 6, IP67
- Due to smaller size, probe sensitivity is reduced, gap max. 13 mm (0.5 inch)



Milltronics XPP-5

- CSA hazardous approval (Class I, Div. 1, Groups A, B, C & D; Class II, Div. 1, Groups E, F & G; Class III)
- Phenolic / aluminum body that is fully potted
- Convenient mounting flange and locknut
- 3/4 inch NPT male hub connection
- Operating temp. from -40 ... +60 °C (-40 ... +140 °F)
- Enclosure rating: Type/NEMA 4X, 6, IP67



Milltronics RMA (Remote Mounted Amplifier)

- Available for internal mounting within Probe, or in enclosure for remote mounting
- Enclosures available in cast aluminum (½" NPT entry), painted steel (Type/NEMA 4 rating) or stainless steel (Type/NEMA 4X, IP65 rating)
- Operating temp. from -40 ... +60 °C (-40 ... +140 °F)
- Enclosure rating: Type/NEMA 4X, 6, IP67



MFA 4p motion probes

Technical specifications

Mode of operation	
Measuring principle	Motion monitor and alarm
Typical application	Monitoring loss of motion in tail pulley, screw flights, bucket elevators
Features	<ul style="list-style-type: none"> • Switch selectable overspeed or underspeed detection • Setpoint adjustment: 0.15 ... 3 000 PPM • Adjustable start-up time delay: 0 ... 60 seconds • Visual indication of probe operation and relay status
Output	2 relays working in unison, each providing 1 SPDT Form C relay contact, rated 8 A at 250 V AC resistive
Performance	
Repeatability	± 1 %
Dead band	± 0.25 %

Dynamic Range	0 ... 7 200 PPM
Ambient Temperature Range	-20 ... +50 °C (-5 ... +122 °F)
Design	
Enclosure rating	Type 4X/NEMA 4X/IP65 (standard and optional stainless steel) Type 4/NEMA 4/IP65 (optional mild steel)
Enclosure dimensions	160 x 240 x 82 mm (6.3 x 9.5 x 3.2 inch) optional: mild steel or 304 (1.4301) stainless steel 203 x 254 x 102 mm (8 x 10 x 4 inch)
Enclosure material	Polycarbonate optional: mild steel or stainless steel
Power Supply	100/115/200/230 V AC switch selectable, 50/60 Hz, 15 VA ± 10 % of rated voltage
Certificates and approvals	CE, C-TICK, CSA _{US/C} , FM

Selection and Ordering data	Order No.
MFA 4P Motion Failure Alarm Controller A highly sensitive single setpoint motion sensor system, used with MSP and XPP probes.	7MH7144-
Enclosure NEMA 4X, polycarbonate enclosure NEMA 4, painted mild steel enclosure NEMA 4X, 304 (1.4301) stainless steel enclosure	1 2 3
Input Voltage 100/115/200/230 V AC, 50/60 Hz, switch selectable	A
Speed detection version Standard, underspeed (U/S) or overspeed (O/S), switch selectable Slow speed (S/S), U/S or O/S detection, switch selectable (limit of 15 ppm)	A B
Approvals CE, C-TICK, CSA _{USIC} , FM	2

Selection and Ordering data	Order code
Further designs Please add "-Z" to Order No. and specify Order code(s).	
Manufacturer's test certificate: According to EN 10204-2.2	C11
Acrylic coated, stainless steel tag [69 x 50 mm (2.7 x 1.97 inch)]: Measuring-point number/identification (max. 27 characters), specify in plain text	Y15
Painted mild steel, heated enclosure with viewing window for use down to -50 °C (-58 °F) (finished unit is mounted inside enclosure) 483 x 584 x 203 mm (19 x 23 x 8 inch)	A35
Stainless steel, sun/weather shield (finished unit is field mounted inside enclosure) [357 x 305 x 203 mm (14 x 12 x 8 inch)]	S50
Operating Instructions	Order No.
English	7ML1998-5FM01
French	7ML1998-5FM11
Spanish	7ML1998-5FM21
German	7ML1998-5FM31
Note: The operating instructions should be ordered as a separate item on the order.	
Spare Parts	
Relay	7MH7723-1DW
Transformer	7MH7723-1DX
Circuit Card, standard	7MH7723-1DU
Circuit Card, Slow speed	7MH7723-1DV
Lid with overlay for MFA 4p	7MH7723-1GY

Selection and Ordering data	Order No.
Milltronics RMA Remote Mounted Amplifier Remote mounted amplifier for Milltronics MSP-1, MSP-3 and MSP-9 motion sensing probes.	7MH7145-
Enclosure Aluminum enclosure, IP65, Type/NEMA 4X, ½" NPT entry Painted steel, Type/NEMA 4, IP65 rating 304 (1.4301) stainless steel enclosure, Type/NEMA 4X, IP65 rating	0 A C D

Selection and Ordering data	Order code
Further designs Please add "-Z" to Order No. and specify Order code(s).	
Manufacturer's test certificate: According to EN 10204-2.20	C11
Acrylic coated, stainless steel tag [38 x 51 mm (1.5 x 2 inch)]: Measuring-point number/identification (max. 16 characters), specify in plain text	Y18
Operating Instructions	Order No.
English	7ML1998-5FM01
French	7ML1998-5FM11
Spanish	7ML1998-5FM21
German	7ML1998-5FM31
Note: The operating instructions should be ordered as a separate item on the order. This device is shipped with the Siemens Milltronics manual CD containing the complete operating instructions library.	
Spare Parts	
Card, RMA	7MH7723-1DT

Process Protection

Motion sensors

Milltronics MFA 4p

Selection and Ordering data

Order No.

Milltronics Motion Sensing Probes

7MH7146-

A series of motion sensing probes used with the MFA 4p.

Milltronics MSP-1: miniature motion sensing probe

Milltronics MSP-3: heavy-duty, high temperature aluminum

Milltronics MSP-9: heavy-duty, high temperature stainless steel

Milltronics MSP-12: heavy-duty, general purpose

Milltronics XPP-5: hazardous rated

Note: Milltronics MSP-1, MSP-3 and MSP-9 probes require the use of Milltronics RMA (amplifier)

Cable Length

Standard length (as described in Model options)¹⁾

Add order code Y01 and plain text:

"Total cable length ... m"

Extended cable length 2 ... 30 m (6.6 ... 98.4 ft)²⁾

Extended cable length 31 ... 50 m

(101.7 ... 164 ft)³⁾

Extended cable length 51 ... 100 m

(167.3 ... 328.1 ft)

Model [standard cable length/type]

MSP-1 [1.8 m (6 ft)]⁴⁾

MSP-3, ½" NPT cable inlet⁴⁾

[1.5 m (5 ft) high temperature cable]

MSP-9 [1.5 m (5 ft) high temperature cable]⁴⁾

MSP-12, ½" NPT cable inlet

XPP-5 [1.5 m (5 ft) cable, (CSA Class I,

Group A, B, C and D; Class II Group E, F and G)]

XPP-5 [10 m (32.8 ft) cable, (CSA Class I, Group

A, B, C and D; Class II Group E, F and G)]

XPP-5 [15 m (49.2 ft) cable, (CSA Class I, Group

A, B, C and D; Class II Group E, F and G)]

Approvals

CE, C-TICK

1) No Y01 needed in order code for standard length

2) Only available with model options A, B, D, G, H, and J

3) Available with Model option G only

4) MSP-1, MSP-3 and MSP-9 probes required the use of RMA (amplifier)

Selection and Ordering data

Order code

Further designs

Please add "-Z" to Order No. and specify Order code(s).

Total cable length: enter the total cable length in plain text description

Y01

Acrylic coated, stainless steel tag

[13 x 45 mm (0.5 x 1.75 inch)]:

Measuring-point number/identification

(max. 16 characters), specify in plain text

Y17

Cable gland kit

A57

Manufacturer's test certificate: According to EN 10204-2.2

C11

Operating Instructions

Order No.

English

7ML1998-5FM01

French

7ML1998-5FM11

Spanish

7ML1998-5FM21

German

7ML1998-5FM31

Note: The operating instructions should be ordered as a separate item on the order.

This device is shipped with the Siemens Milltronics manual CD containing the complete operating instructions library.

Spare Parts

Locknut, for MSP-1

7MH7723-1CQ

Locknut, for MSP-3, MSP-4, MSP-12, XPP-5

7MH7723-1CR

Mounting flange, for MSP-3, MSP-4, MSP-12, XPP-5

7MH7723-1CS

Mounting bracket for MSP-9

7MH7723-1CT

Lid, 1/2" NPT cable inlet, for MSP-3, MSP-12

7MH7723-1CU

Lid for MSP-9

7MH7723-1CV

Lid gasket, for MSP-3, MSP-9

7MH7723-1CW

Lid gasket, for MSP-12

7MH7723-1CX

Motion cable gland adaptor kit

7MH7723-1JU

Dimensional drawings

Type 4X/NEMA 4X/IP65 Polycarbonate Enclosure

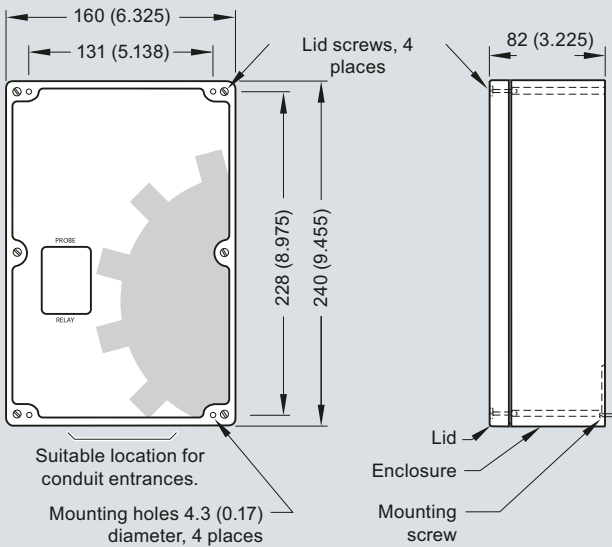

Type 4/NEMA 4/IP65 Painted Steel Enclosure & Type 4X/NEMA 4X/IP65 Stainless Steel Enclosure

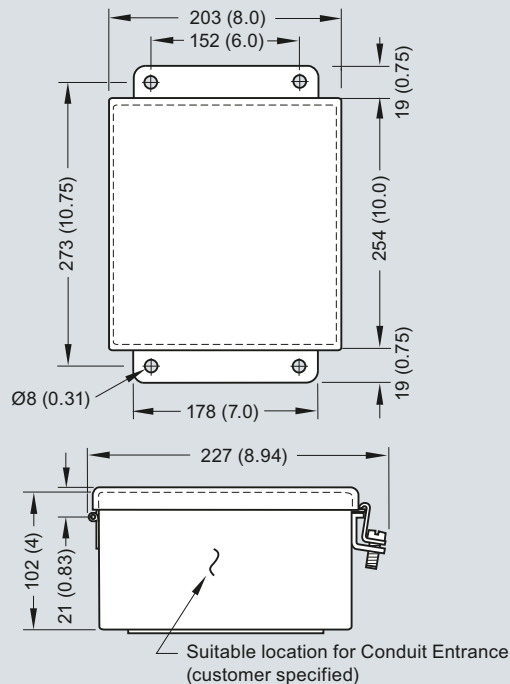

Standard Probe MSP-12

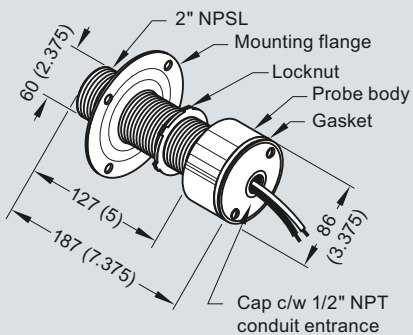

Hazardous Locations XPP-5

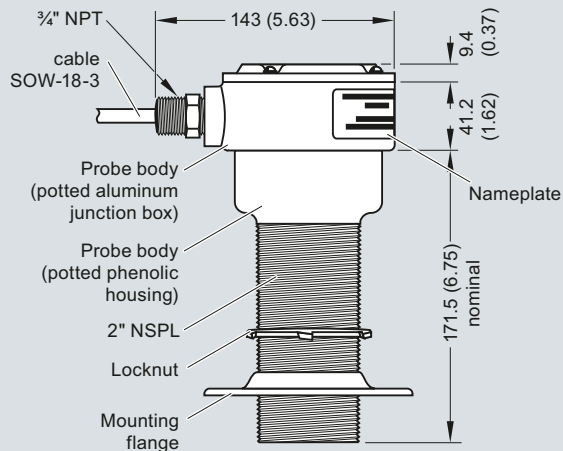

MFA 4p and probe, dimensions in mm (inch)

Process Protection

Motion sensors

Milltronics MFA 4p

Mini sensing probe MSP-1

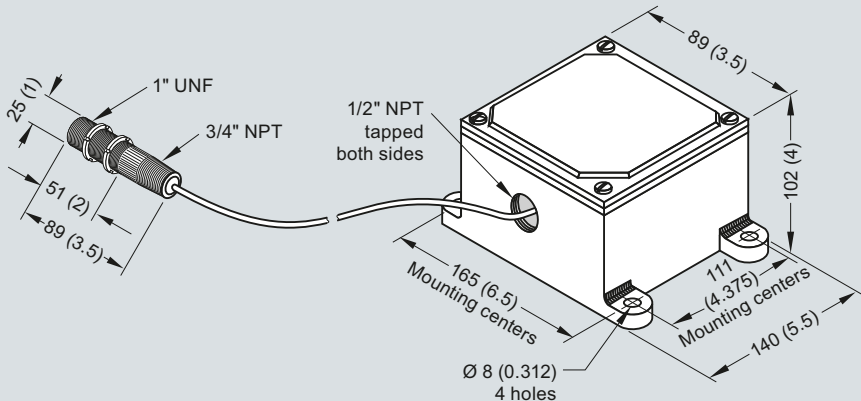

High temperature probe MSP-3

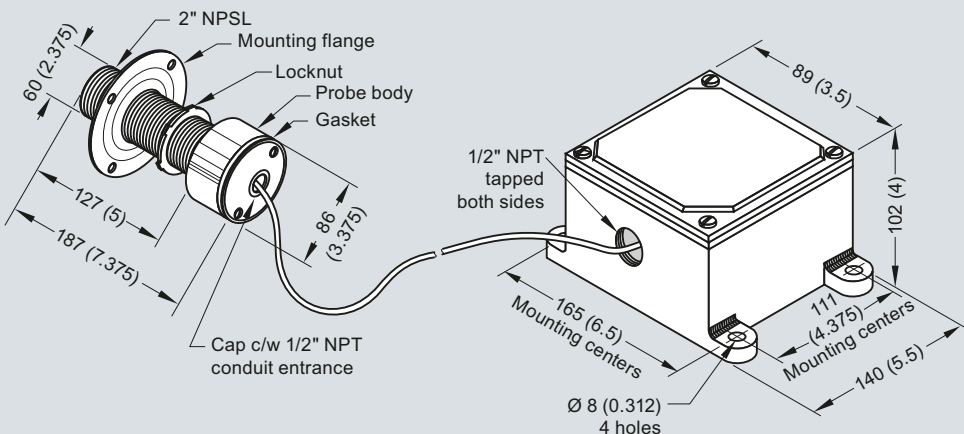

High temperature stainless steel probe MSP-9

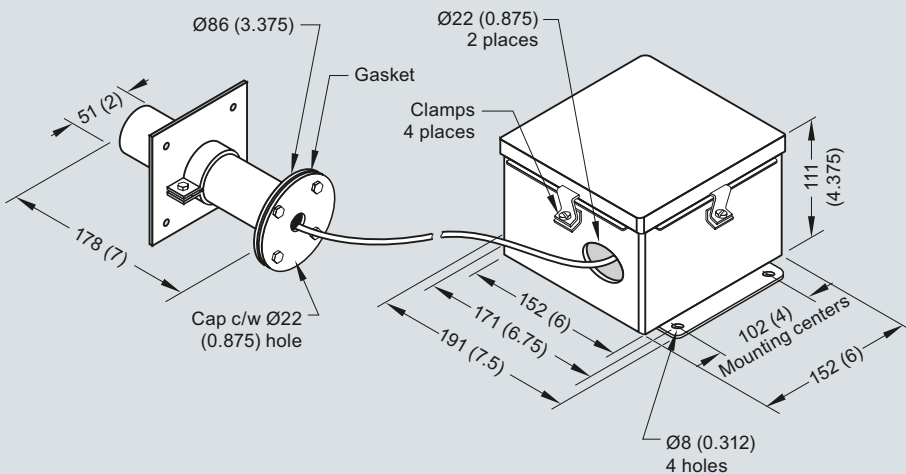

Probe, dimensions in mm (inch)

6

Overview



Milltronics Millpulse 600 is a heavy-duty 2-wire motion sensor that provides solid state switch output to PLCs between 18 to 135 V AC or DC.

Benefits

- Up to 100 mm (4 inch) gap between Millpulse and targets
- Two-wire unit
- PLC compatible
- Rugged, low maintenance suitable for tough environments
- Visual indication of target triggered pulses

Application

Millpulse supplies cost-effective equipment protection even in the harshest conditions.

This rugged unit is impervious to dust, dirt, build-up, and moisture, and is ideal for such primary industries as mining, aggregate, and cement plants. Operating where other systems are prone to failure, the non-contacting design eliminates the need for lubricating, cleaning, and part replacement. It will reduce downtime and clean-up expenses associated with conveying equipment failure. Its pulse output can be used to minimize spillage, prevent damage, detect fire caused by belt slippage at the head pulley, and warn of other conveyor malfunction.

The Millpulse 600 offers underspeed, overspeed, differential speed, and speed indication functions by a PLC. With an all aluminum body, it operates from -45 to +60 °C (-49 to +140 °F).

- Key Applications: tail pulleys, driven pulleys, motor shaft sensing, screw conveyor flights, bucket elevators

Design

Mounting

The Millpulse 600 should be mounted in an area classified as non-hazardous, that is suitable to the enclosure rating and materials and is within the temperature range specified. The cap should be accessible to allow for wiring and viewing of the status display LED.

When mounting the Millpulse onto a vibration-free structure, use the supplied mounting flange to ensure that there is no danger of the target damaging the unit.

Where possible, mount the probe so the cable inlet is pointing downward to avoid accumulation of condensation in the casing. Where wiring must be run in conduit, use a flexible conduit for easier removal or adjustment of the probe. Keep the Millpulse away from high voltage or current runs, contactors and the variable frequency drives.

Do not connect the Millpulse 600 directly to supply.

Technical specifications

Mode of operation	
Measuring principle	Disruption of magnetic field by ferrous target
Typical application	Provides pulse output to PLC when monitoring screw conveyor flight
Rated operating conditions	
Operating temperature	-45 ... +60 °C (-49 ... +140 °F)
Design	
Probe body	Aluminum
Process mounting	2" NPSL
Connection box	Aluminum, ¾" NPT conduit entrance, 4 screw terminals for max. 12 AWG (3.30 mm ²) wire size
Gasketing	Neoprene
Display	Red LED for switch status
Enclosure rating	Type NEMA 4X, 6, IP67
Shipping weight	2 kg (4.4 lb)
Power supply	
Switching capability	Voltage <ul style="list-style-type: none"> • 18 ... 48 V AC/DC • 60 ... 135 V AC/DC Current <ul style="list-style-type: none"> • 5 ... 400 mA continuous, 2 A surge for 20 ms at 1 operation per second
Voltage drop	8 V
Residual current	1.5 mA
Switch duration	On: 50 ms minimum Off: 50 ms minimum
Dynamic range	Minimum 6 pulses per minute Maximum 600 pulses per minute
Certificates and approvals	CSA _{US/C} , CE, C-TICK

Process Protection

Motion sensors

Milltronics Millpulse 600

Selection and Ordering data	Order No.	Selection and Ordering data	Order code
Milltronics Millpulse 600 Heavy-duty 2-wire motion sensor that provides solid state switch output to PLCs between 18 ... 135 V AC or DC.		Further designs Please add "-Z" to Order No. and specify Order code(s).	
Model Millpulse 600, aluminum enclosure, 3/4" NPT, CE, C-TICK, CSA _{US/C} approved (switches 18 ... 135 V AC/DC)	7MH7142-0AA10	Manufacturer's test certificate: According to EN 10204-2.2 Acrylic coated, stainless steel tag [13 x 45 mm (0.5 x 1.75 inch)]: Measuring-point number/identification (max. 16 characters), specify in plain text	C11 Y17
		Operating Instructions Millpulse 600, English Millpulse 600, German Millpulse 600, Spanish Note: The operating instructions should be ordered as a separate item on the order. This device is shipped with the Siemens Milltronics manual CD containing the complete operating instructions library.	Order No. 7ML1998-5DG02 7ML1998-5DG31 7ML1998-5DG22
		Spare Parts Locknut Mounting flange Motion cable gland adaptor kit	7MH7723-1CR 7MH7723-1CS 7MH7723-1JN

Dimensional drawings

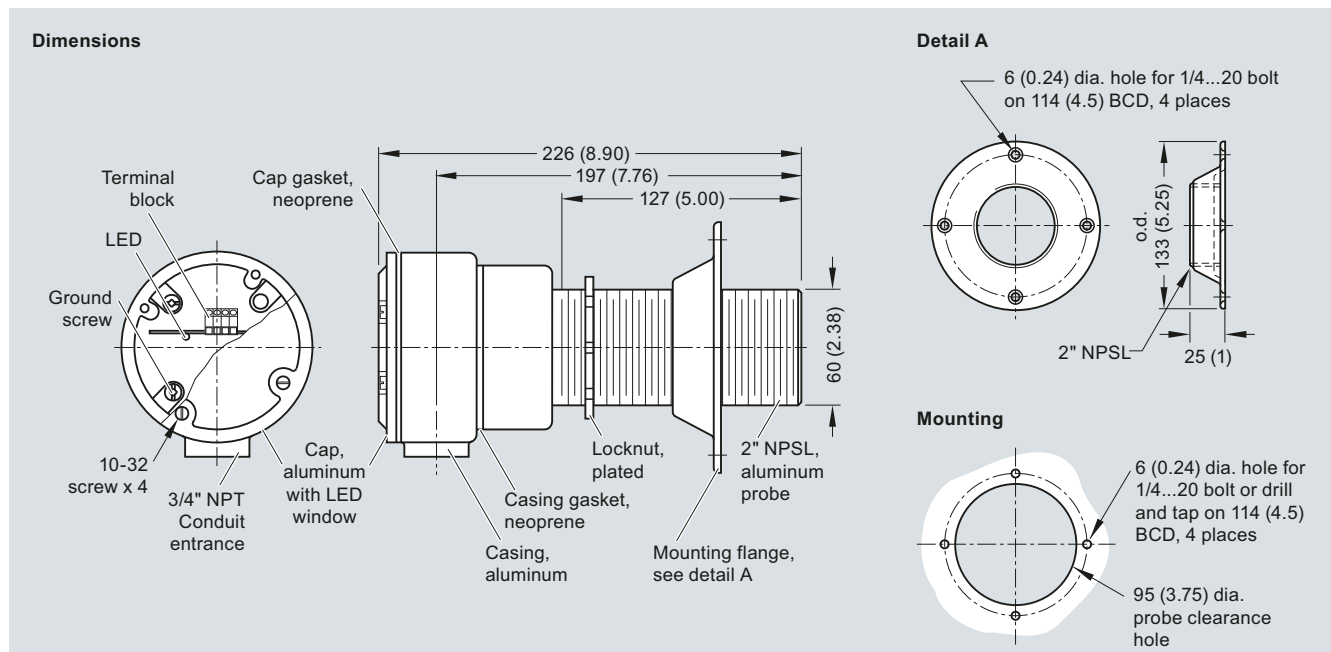

Millpulse 600 mounting, dimensions in mm (inch)

Schematics

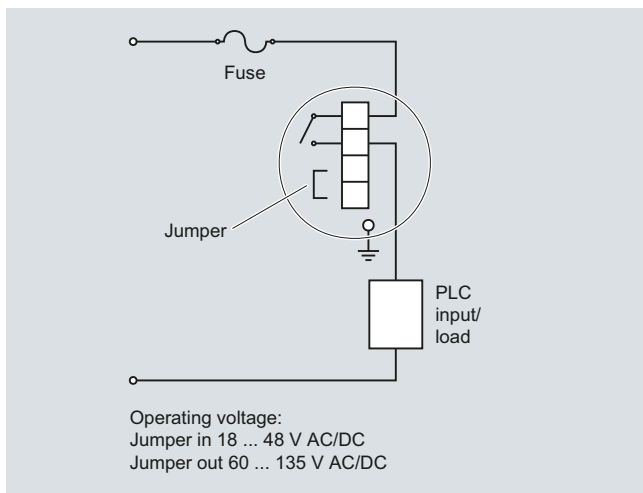

Millpulse 600 mounting, dimensions in mm (inch)

Interconnection

If the manufacturer of your PLC does not state that it is compatible with CENELEC 50040/36/37/38 electrical standards, then ensure that the switching current of the PLC input is above the residual current of the MillPulse. If your PLC does not meet the requirements, a resistor across the PLC inputs can be used to increase the switching current.

Process Protection

Motion sensors

SITRANS WM100

Overview



SITRANS WM100 is a heavy-duty zero-speed alarm switch. This non-contacting unit provides cost-effective equipment protection even in the harshest conditions.

Benefits

- Up to 100 mm (4 inch) gap between SITRANS WM100 and targets
- Rugged, low maintenance suitable for tough environments
- 1 SPDT Form C relay contact
- Provides cost-effective protection
- Visual indication of target triggered pulse

Application

This rugged unit is impervious to dust, dirt, build-up and moisture and is ideal for such primary industries as mining, aggregate, and cement. Operating where other systems are prone to failure, the non-contacting design eliminates the need for lubricating, cleaning and part replacement. Downtime and clean-up expenses associated with conveying equipment failure are reduced by the SITRANS WM100. It alarms to minimize spillage, prevent extensive damage or even fire caused by belt slippage at the head pulley and warn against conveyor malfunction.

The SITRANS WM100 has built-in selectable start delays and 1 Form C relay contact. With an aluminum body, it operates from -40 to +60 °C (-40 to +140 °F).

- Key Applications: tail pulleys, driven pulleys, motor shaft sensing, screw conveyor flights, bucket elevators

Design

Mounting

The WM100 probe should be mounted, using the supplied mounting flange, onto a vibration-free structure. The gap between the probe and the target should be sufficient such that there is no danger of the target damaging the probe. The maximum allowable gap is 100 mm (4 inch) from the face of the target to the face of the probe for 4.5 x 4.5 mm (3/16 x 3/16 inch) keyway. The WM100 is sensitive to lateral disturbances to its magnetic field. If the WM100 is responding to motion from an interfering target, move the WM100 or install a ferrous plate (steel) as a shield between the WM100 and the interfering target. Where possible, the probe should be mounted such that the cable inlet is pointing downward to avoid accumulation of condensation in the casing. Connection of the probe should be made via flexible conduit for easier removal or adjustment of the probe.

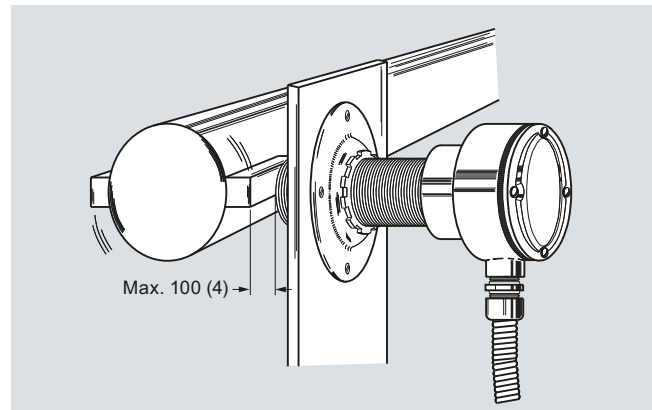

SITRANS WM100 mounting, dimensions in mm (inch)

Technical specifications

Mode of operation	
Measuring principle	Disruption of magnetic field by ferrous target
Typical application	Monitors absence or presence of motion in harsh conditions
Output	
Contact	1 SPDT Form C dry relay contact, rated 5 A at 250 V AC, fail-safe operation
Time delay	Start up: 10 ... 14 seconds (5 ... 7 seconds with 12 ppm jumper installed)
Zero Speed (selected via a common jumper)	<ul style="list-style-type: none"> • 5 seconds ± 1 (minimum speed 10 ... 15 ppm) or • 10 seconds ± 2 (minimum speed 5 ... 7.5 ppm)
Rated operating conditions	
Operating temperature	-40 ... +60 °C (-40 ... +140 °F)
Design	
Probe body	Aluminum
Process mounting	2" NPSL
Connection box	Aluminum, 3/4" NPT conduit entrance, 5 screw terminals plus grounding terminal for electrical connection, max. 12 AWG (3.30 mm ²) wire size
Gasketing	Neoprene
Display	Red LED for verification of pulses
Enclosure rating	Type NEMA 4x, 6, IP67
Dynamic range	Minimum 6 or 12 pulses per minute Maximum 3 000 pulses per minute
Shipping weight	2 kg (4.4 lb)
Power supply	<ul style="list-style-type: none"> • 115 V AC/50 ... 60 Hz, 7 VA • 230 V AC/50 ... 60 Hz, 7 VA • ± 10 % of rated voltage
Certificates and approvals	CSA _{US/C} , CE, C-TICK

Selection and Ordering data	Order No.	Selection and Ordering data	Order code
SITRANS WM100 A heavy-duty zero-speed alarm switch that does not require a controller.	7MH7158 - 0 A 0 0	Further designs Please add "-Z" to Order No. and specify Order code(s).	
Model 115 V AC 230 V AC	A B	Manufacturer's Test Certificate: According to EN 10204-2.2 Acrylic coated, stainless steel tag [13 x 45 mm (0.5 x 1.75 inch)]: Measuring-point number/identification (max. 16 characters), specify in plain text	C11 Y17
		Operating Instructions SITRANS WM100, English SITRANS WM100, German Note: The operating instructions should be ordered as a separate item on the order. This device is shipped with the Siemens Milltronics manual CD containing the complete operating instructions library.	Order No. 7ML1998-5MW01 7ML1998-5MW31
		Locknut, for WM100 and Millpulse 600	7MH7723-1CR
		Mounting flange, for WM100 and Millpulse 600	7MH7723-1CS
		Motion cable gland adaptor kit	7MH7723-1JN

Dimensional drawings

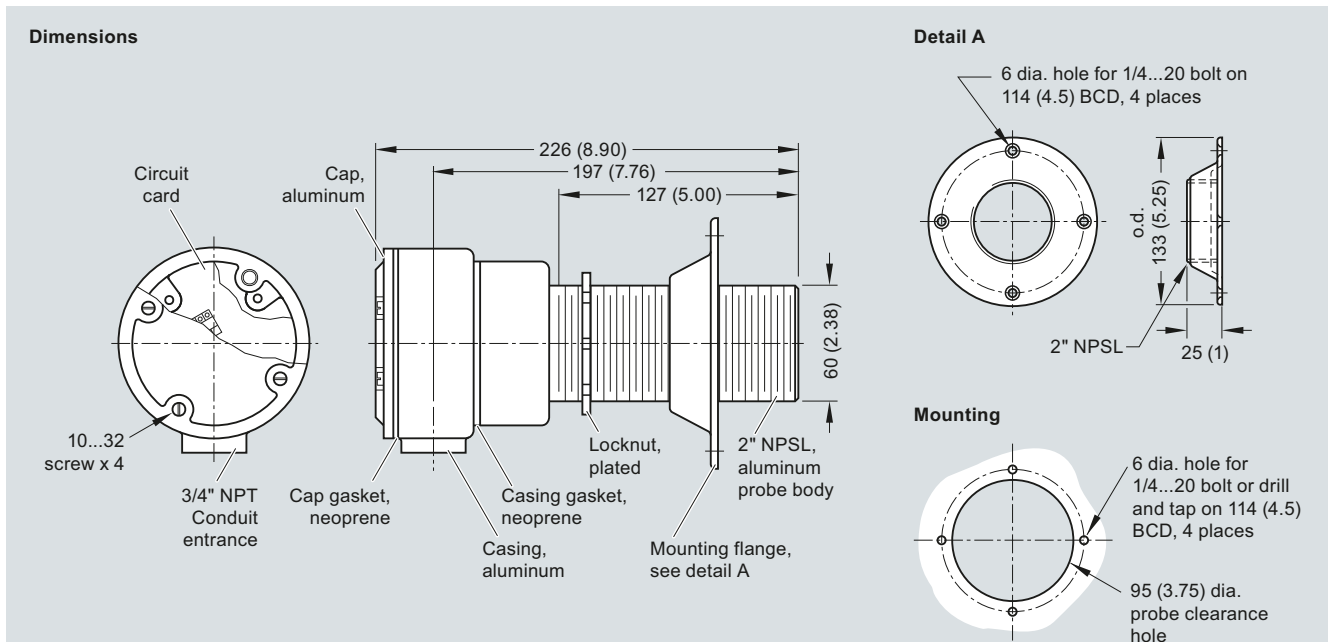

SITRANS WM100 mounting, dimensions in mm (inch)

Process Protection

Motion sensors

SITRANS WM100

Schematics

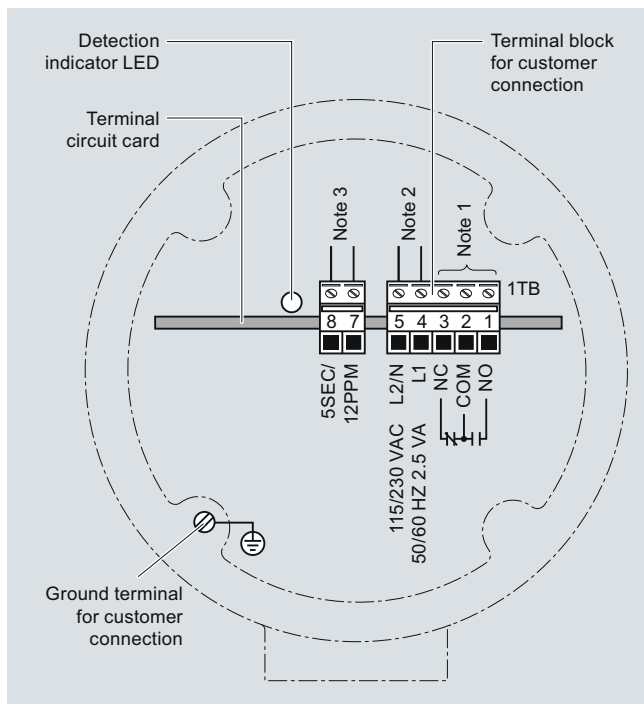

SITRANS WM100 wiring

Notes:

1. Dry contacts shown in de-energized (alarm or shelf) state.
2. SITRANS WM100 is manufactured for either 115 or 230 V AC operation. Check WM100 nameplate for applicable voltage. Correct voltage must be supplied. Voltages lower than specified will result in an inoperative condition. Voltages higher than specified will severely damage unit.
3. For 5 second time delay and a minimum 12 ppm range, connect jumper across terminals 7 and 8. Without a jumper, the default is a 10 second time delay and a minimum 6 ppm range.