

## Load Cells



## 3/2 Introduction

**SIWAREX WL200-  
SIWAREX WL260 SP-S AA**

3/7 Load cell

**SIWAREX WL200-  
SIWAREX WL260 SP-S AB**

3/9 Load cell

**SIWAREX WL200-  
SIWAREX WL260 SP-S SA**

3/10 Load cell

**SIWAREX WL200-  
SIWAREX WL250 ST-S SA**

3/12 Load cell

**SIWAREX WL200-  
SIWAREX WL230 BB-S SA**

3/14 Load cell

3/16 Base plate with overload protection

3/17 Elastomer bearing

3/18 Compact mounting unit

**SIWAREX WL200-  
SIWAREX WL230 SB-S SA**

3/19 Load cell

3/21 Compact mounting unit

**SIWAREX WL200-  
SIWAREX WL270 CP-S SA**

3/22 Load cell

3/24 Pressure pieces and adapter plate

3/25 Compact mounting unit

**SIWAREX WL200-  
SIWAREX WL270 CP-S SB**

3/26 Load cell

3/28 Pressure piece set

3/29 Compact mounting unit

**SIWAREX WL200-  
SIWAREX WL270 CP-S SC**

3/30 Load cell

**SIWAREX WL200-  
SIWAREX WL270 K-S CA**

3/31 Load cell

3/33 Self-aligning bearing

**SIWAREX WL200-  
SIWAREX WL280 RN-S SA**

3/34 Load cell

3/43 Self-aligning bearing

3/45 Elastomer bearing

3/47 Compact mounting unit

3/48 Guide element for  
compact mounting unit**SIWAREX WL200 - Accessories**3/49 SIWAREX JB junction box,  
Aluminum enclosure3/51 SIWAREX JB junction box,  
Stainless steel enclosure3/53 SIWAREX EB  
Extension box

3/54 Grounding cable

**SIWAREX R**

3/55 Overview

Technical specifications, Ordering data

3/56 - Platform and Bending beam load cells

3/58 - Shear beam load cells

3/60 - Bending ring load cells

3/62 - Compression load cells

3/64 - SIWAREX R junction boxes

3/65 - SIWAREX R accessories

**Configuration examples**

3/66 Introduction

3/67 Configuration example 1

3/68 Configuration example 2

3/69 Configuration example 3

# Load cells

## Introduction

### Overview



Siemens offers two load cell series: SIWAREX R and SIWAREX WL200. Both series are equipped with strain gauges. They are used for static and dynamic weight measurements.

The different load cell series cover rated loads from 3 kg (6.61 lb) to 280 t (275.58 tn. L.).

The variety of modules available and their characteristics, including



- Stainless steel version for a high degree of corrosion protection (not with SIWAREX R series K, SIWAREX WL260 SP-S AA and SP-S AB)
- Hermetically sealed housing for use in even harsh and aggressive environments (not with SIWAREX R series K)
- Compact modules for easy installation
- SIWAREX load cells are suitable for virtually all applications in industrial weighing, e.g. container and hopper scales, platform scales, vehicle scales, hybrid scales etc.



All series have been approved for use with Class III legal-for-trade commercial scales in accordance with EN 45501 and conform to OIML R60<sup>1)</sup>.

Load cells can also be supplied for other rated loads, higher accuracy, and/or with EEx (i) approval.

<sup>1)</sup> This does not apply to SIWAREX R series K, SIWAREX WL270 K-S CA or SIWAREX WL270 CP-S SC. Approvals for the types SIWAREX WL230 SB-S SA, 5 t (4.92 tn. L.), SIWAREX WL260 SP-S AB and SIWAREX WL260 SP-S SA will be available soon.

### Overview (continued)

Design	Platform				
Series	WL260 SP-S AA			WL260 SP-S AB	WL260 SP-S SA
Picture					
Rated load $E_{max}$	3, 5, 10 kg (6.61, 11.02, 22.05 lb)	20, 50 kg (44.09, 110.23 lb)	100 kg (220.46 lb)	50 ... 100 kg (110.23 ... 220.46 lb)	5 ... 200 kg (11.02 ... 440.92 lb)
Approval	C3 acc. to OIML R60			C3 acc. to OIML R60	<ul style="list-style-type: none"> <li>• C3 acc. to OIML R60</li> <li>• ATEX</li> </ul>
Min. load cell verification interval ( $V_{min}$ )	$E_{max}/15\ 000$	$E_{max}/7\ 500$	$E_{max}/12\ 000$	$E_{max}/10\ 000$	$E_{max}/7\ 500$
Rated characteristic value	2 mV/V			2 mV/V	2 mV/V
Degree of protection	IP65			IP65	IP67
Material	Aluminum			Aluminum	Stainless steel
Mounting units	-	-	-	-	-

Design	Bending beam	Shear beam	
Series	WL230 BB-S SA	WL230 SB-S SA	
Picture			
Rated load $E_{max}$	<ul style="list-style-type: none"> <li>• 10<sup>1)</sup> ... 100 kg</li> <li>• (22.05<sup>1)</sup> ... 220.46 lb)</li> <li>• 200 kg (440.92 lb)</li> <li>• 350 kg (771.62 lb)</li> <li>• 500 kg (1102.31 lb)</li> </ul>	500 kg (1102.31 lb)	<ul style="list-style-type: none"> <li>• 1 t (0.98 tn. l.)</li> <li>• 2 t (1.97 tn. l.)</li> <li>• 5 t (4.92<sup>2)</sup> tn. L.)</li> </ul>
Approval	<ul style="list-style-type: none"> <li>• C3 acc. to OIML R60</li> <li>• ATEX</li> </ul>		<ul style="list-style-type: none"> <li>• C3 acc. to OIML R60<sup>2)</sup></li> <li>• ATEX</li> </ul>
Min. load cell verification interval ( $V_{min}$ )	$E_{max}/15\ 000$	$E_{max}/10\ 000$	$E_{max}/15\ 000$
Rated characteristic value $C_N$	2 mV/V		2 mV/V
Degree of protection	IP68		IP68
Material	Stainless steel		Stainless steel
Mounting units	<ul style="list-style-type: none"> <li>• Base plate with overload protection</li> <li>• Elastomer bearings</li> <li>• Compact mounting unit</li> </ul>		Compact mounting unit



<sup>1)</sup> OIML R60 type approval for WL260 SP-S AB available soon

<sup>2)</sup> OIML R60 type approval for WL230 SB-S SA, 5 t available soon





# Load cells

## Introduction

### Overview (continued)

Design	S-type			Ring-torsion load cell		
Series	WL250 ST-S SA			WL280 RN-S SA		
Picture						
Rated load $E_{max}$	50 ... 100 kg (110.23 ... 220.46 lb)	0.25 ... 2.5 t (0.25 ... 2.46 tn. L.)	5 ... 10 t (4.92 ... 9.84 tn. L.)	60 ... 280 kg (132.28 ... 1617.29 lb)	0.5 ... 5 t (0.49 ... 4.92 tn. L.)	10 ... 60 t (9.84 ... 59.05 tn. L.)
Approval	<ul style="list-style-type: none"> <li>• C3 acc. to OIML R60</li> <li>• ATEX</li> </ul>			<ul style="list-style-type: none"> <li>• C3 acc. to OIML R60</li> <li>• ATEX<sup>1)</sup></li> </ul>		
Min. load cell verification interval ( $V_{min}$ )	$E_{max}/7\ 000$	$E_{max}/10\ 000$	$E_{max}/12\ 000$	$E_{max}/16\ 000$	$E_{max}/17\ 050$	$E_{max}/17\ 500$
Supply voltage ( $U_{sr}$ )	5 ... 12 V			5 ... 30 V		
Rated characteristic value $C_N$	3 mV/V			1 mV/V	2 mV/V	2 mV/V
Degree of protection	IP67			IP66/IP68		
Mounting units	-			<ul style="list-style-type: none"> <li>• Elastomer bearings</li> <li>• Self-aligning bearings</li> <li>• Compact mounting unit</li> <li>• Guide element for compact mounting unit</li> </ul>		

<sup>1)</sup> ATEX certification available soon

Design	Compression cell			
Series	WL270 CP-S SA	WL270 CP-S SB	WL270 CP-S SC	WL270 K-S CA
Picture				
Rated load $E_{max}$	<ul style="list-style-type: none"> <li>• 10 t (9.84 tn. L.)</li> <li>• 20 t (19.68 tn. L.)</li> <li>• 30 t (33.07 tn. L.)</li> <li>• 60 t (49.21 tn. L.)</li> </ul>	100 t (98.42 tn. L.)	200 t (196.84 tn. L.)	2.8 ... 280 t (2.76 ... 275.58 tn. L.)
Approval	<ul style="list-style-type: none"> <li>• C3 acc. to OIML R60</li> <li>• ATEX</li> </ul>	<ul style="list-style-type: none"> <li>• C3 acc. to OIML R60</li> <li>• ATEX</li> </ul>	ATEX	-
Min. load cell verification interval ( $V_{min}$ ) or accuracy class	$E_{max}/10\ 000$	$E_{max}/9\ 000$	0.1 %	0.1 %
Supply voltage ( $U_{sr}$ )	5 ... 12 V	5 ... 12 V	5 ... 12 V	6 ... 12 V
Rated characteristic value $C_N$	2 mV/V	2 mV/V	2 mV/V	1.5 mV/V
Degree of protection	IP68	IP68	IP68	IP66
Mounting units	<ul style="list-style-type: none"> <li>• Pressure pieces and adapter plates</li> <li>• Compact mounting unit</li> </ul>	Compact mounting unit	-	Self-aligning bearings

**Design**

Load cells are sensors that convert a mechanical variable (i.e. weight) into an electrical signal, usually a voltage.

They work with different measuring principles. Siemens load cells in the SIWAREX WL200 and SIWAREX R series use so-called strain gauges. These are specially formed electrical conductors which are insulated by means of a suitable material. The strain gauges are attached to the basic element, a specially formed spring body, by friction locking.

Under the influence of a weight force  $F$ , the spring body is deformed (see schematic presentation) and as a result the strain gauge deforms elastically. Due to the change in the external shape of the strain gauge, the ohmic resistance of its conductor also changes. The top left and bottom right strain gauges are compressed, their resistance films are shortened and the ohmic resistance is reduced accordingly. The top right and bottom left strain gauges are stretched, their resistance films are extended and the ohmic resistance is increased.

For each load cell, at least 4 strain gauges are connected together to form a complete Wheatstone bridge. The stretched or compressed strain gauges are connected so that the positive or negative resistance changes are added together to form a total imbalance in the bridge.

On one bridge diagonal, the power voltage is applied (with 6-conductor technique, also the sensor voltage, SENSE) and on the other diagonal, the measured voltage is tapped.

With a constant power voltage (EXC), the measured voltage (SIG) changes proportionally to the introduced load.

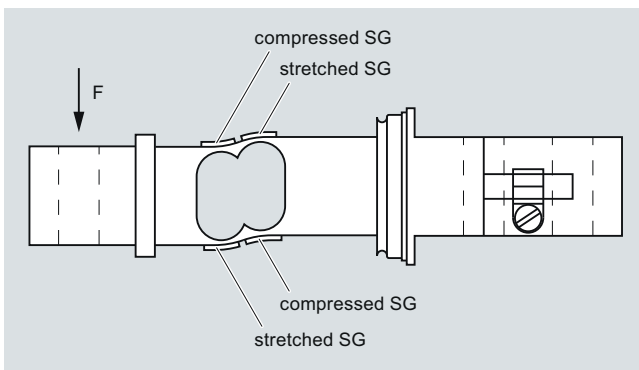
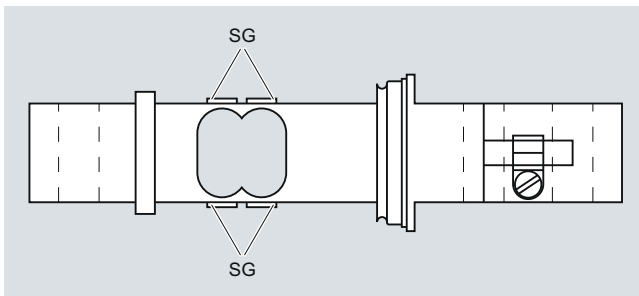

Principle of a bending load cell, unloaded and loaded

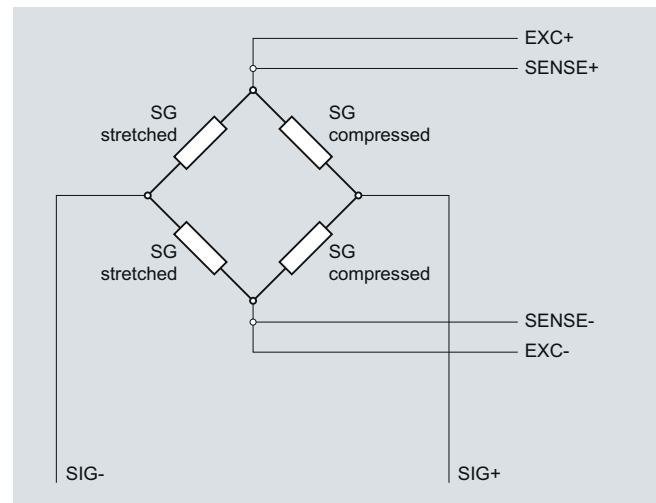

Principle of a Wheatstone bridge

# Load cells

## Introduction

**Design** (continued)

## SIEMENS

### Questionnaire SIWAREX

#### Customer information

Contact: \_\_\_\_\_ E-mail: \_\_\_\_\_  
 Company: \_\_\_\_\_ Prepared by : \_\_\_\_\_  
 Address: \_\_\_\_\_ Date : \_\_\_\_\_  
 City: \_\_\_\_\_ Country: \_\_\_\_\_ Notes on application: \_\_\_\_\_  
 Zip/Postal Code: \_\_\_\_\_ Phone: ( \_\_\_\_\_ ) Fax: ( \_\_\_\_\_ )

### Electronics

#### Application type

- |  |  |  |
|--|--|--|
| <input type="checkbox"/> Non Automatic Weighing Instrument | <input type="checkbox"/> Truck/Wagon scale static        | <input type="checkbox"/> Checkweigher                |
| <input type="checkbox"/> Platform Scale                    | <input type="checkbox"/> Automatic filling/Big Bag scale | <input type="checkbox"/> Solid flow meter            |
| <input type="checkbox"/> Vessel/Silo/level measurement     | <input type="checkbox"/> Dosing scale                    | <input type="checkbox"/> Weighfeeder                 |
| <input type="checkbox"/> Truck scale                       | <input type="checkbox"/> Belt scale                      | <input type="checkbox"/> Loss in weight dosing scale |
| <input type="checkbox"/> Force measurement                 |  |  |

Type of material: \_\_\_\_\_

#### Requested features

- |   |  |   |
|---|--|---|
| <input type="checkbox"/> Basic weighing functions       | <input type="checkbox"/> Error control and logging | <input type="checkbox"/> Fast weight value processing |
| <input type="checkbox"/> Recording of weighing sequence | <input type="checkbox"/> Preventive diagnostics    | <input type="checkbox"/> Legal-for-trade              |
| <input type="checkbox"/> With Ex approval               | Zone type/number: _____                            |   |

#### SIMATIC integration

- |  |  |                                |
|--|--|--------------------------------|
| <input type="checkbox"/> SIMATIC S7-200 directly     | <input type="checkbox"/> SIMATIC PCS7 Version: _____ | <input type="checkbox"/> Other |
| <input type="checkbox"/> SIMATIC S7-300 directly     | <input type="checkbox"/> WINCC flex Version: _____   | Name: _____                    |
| <input type="checkbox"/> SIMATIC S7-300/400 with bus | Type: _____  |                                |

### SIWAREX Mechanic

#### Load cells

Total maximum weight: \_\_\_\_\_ Dead load : \_\_\_\_\_ Required precision: \_\_\_\_\_  
 Load cells quantity: \_\_\_\_\_ Number of support points: \_\_\_\_\_

- |   |   |   |   |
|---|---|---|---|
| <input type="checkbox"/> Vibration (Motor, Mixer, etc.) | <input type="checkbox"/> Guide elements required? | <input type="checkbox"/> Lift up protection | <input type="checkbox"/> Diagnostics                |
| <input type="checkbox"/> High overload protection       | <input type="checkbox"/> High measuring rate      | <input type="checkbox"/> Ex Protection      | <input type="checkbox"/> Stainless steel required ? |

#### Special application requirements

- Pictures available  Drawing available  Retrofit of an old installation

This questionnaire is only a guideline. For special configurations refer to your Siemens contact person.

## SIWAREX WL200-SIWAREX WL260 SP-S AA

Load cell

## Overview



The load cell is suitable for small platform scales with one load cell (max. platform size 400 x 400 mm (15.75 x 15.75 inch)) as well as for use in medium accuracy weighing machines of Class III with a max. verification interval  $n_{\max} = 3\,000d$ .

## Design

The measuring element is hermetically sealed and has a calibrated output current.

## Technical specifications

## SIWAREX WL260 SP-S AA

<b>Possible applications</b>	<ul style="list-style-type: none"> <li>Platform scales</li> <li>Small conveyor scales</li> </ul>
<b>Model</b>	Platform load cell
<b>Loads</b>	
Rated load $E_{\max}$ .	<ul style="list-style-type: none"> <li>3 kg (6.61 lb)</li> <li>5 kg (11.02 lb)</li> <li>10 kg (22.05 lb)</li> <li>20 kg (44.09 lb)</li> <li>50 kg (110.23 lb)</li> <li>100 kg (220.46 lb)</li> </ul>
Minimum initial loading $E_{\min}$	0 % $E_{\max}$
Maximum working load $L_U$	150 % $E_{\max}$
Ultimate load $L_d$	300 % $E_{\max}$
Maximum lateral load $L_{lq}$	100 % $E_{\max}$
<b>Measurement characteristic values</b>	
Rated measuring path $h_n$ at $E_{\max}$	< 0.6 mm
Rated characteristic value $C_N$	$2.0 \pm 0.2$ mV/V
Tolerance $D_0$ of zero signal	$\pm 2$ % $C_N$
Max. load cell verification interval $n_c$	3 000
Min. load cell verification interval $V_{\min}$	
• $E_{\max} = 3, 5, 10$ kg (6.61, 11.02, 22.05 lb)	$E_{\max}/15\,000$
• $E_{\max} = 20, 50$ kg (44.0, 110.23 lb)	$E_{\max}/7\,500$
• $E_{\max} = 100$ kg (220.46 lb)	$E_{\max}/12\,000$
Combined error $F_{\text{comb}}$	$\pm 0,02$ % $C_N$
Repeatability $F_v$	$\pm 0,017$ % $C_N$
Creep error $F_{cr}$	
• 30 min	$\pm 0,02$ % $C_N$

## Electrical characteristic values

Recommended reference voltage $U_{\text{ref}}$	5 ... 12 V DC
Input resistance $R_e$	$409 \Omega \pm 6 \Omega$
Output resistance $R_a$	$350 \Omega \pm 3 \Omega$
Insulation resistance $R_{is}$	5 000 M $\Omega$ at 50 V DC
Temperature effect	
• Zero signal $T_{K0}$	0.017 % $C_N/5$ K
• Characteristic value $T_{Kc}$	0.014 % $C_N/5$ K

## Connection and ambient conditions

Sensor material (DIN)	Aluminum
Maximum tightening torque of the fixing screws	15 ... 20 Nm
<b>Function</b>	<b>Color</b>
• EXC + (supply +)	Red
• EXC - (supply -)	Black
• SIG + (measured signal +)	Green
• SIG - (measured signal -)	White
• Sense + (sensor line +)	Blue
• Sense - (sensor line -)	Brown
• Shield	Transparent
Rated temperature range $B_{tn}$	-10 ... +40 °C (14 ... 104 °F)
Operating temperature range $B_{tu}$	-35 ... +65 °C (-31 ... +149 °F)
Storage temperature range $B_{ts}$	-35 ... +65 °C (-31 ... +149 °F)
Degree of protection according to EN 60529; IEC 60529	IP65

## Certificates and approvals

Accuracy class according to OIML R60	C3
--------------------------------------	----

## Selection and Ordering data

Order No.

<b>Load cell, type WL260 SP-S AA</b>	<b>7MH5102-</b>
Legal-for-trade according to OIML R60 up to 3 000d, connecting cable 3 m (9.84 ft)	<b>D 0 0</b>
<b>Rated load</b>	
• 3 kg (6.61 lb)	<b>1 K</b>
• 5 kg (11.02 lb)	<b>1 P</b>
• 10 kg (22.05 lb)	<b>2 A</b>
• 20 kg (44.09 lb)	<b>2 G</b>
• 50 kg (110.23 lb)	<b>2 P</b>
• 100 kg (220.46 lb)	<b>3 A</b>

# Load cells

## SIWAREX WL200-SIWAREX WL260 SP-S AA

### Load cell

### Dimensional drawings

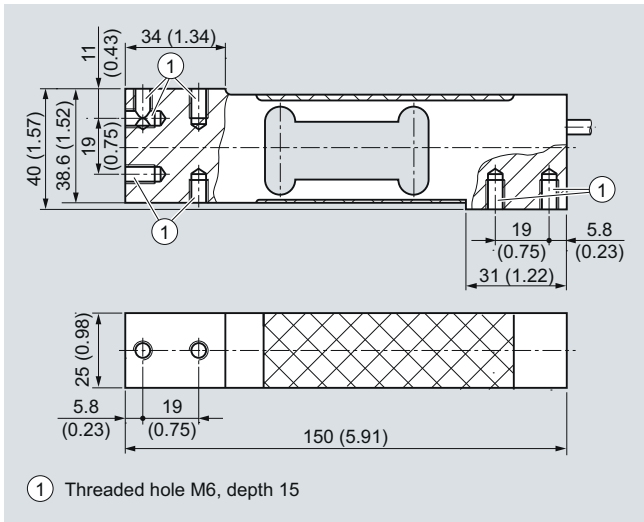

SIWAREX WL260 SP-S AA load cell, dimensions in mm (inch)



# Load cells

## SIWAREX WL200-SIWAREX WL260 SP-S AB

Load cell

### Overview

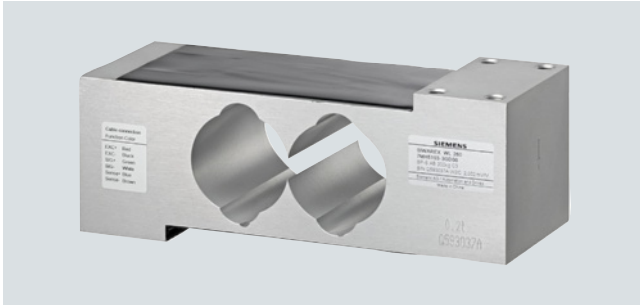

The load cell is suitable for small to medium platform scales with one load cell (max. platform size 600 x 600 mm (23.62 x 23.62 inch)) as well as for use in medium accuracy weighing machines of Class III with a max. verification interval  $n_{\max} = 3\ 000d$ .

### Design

The measuring element is hermetically sealed and has a calibrated output current.

### Technical specifications

#### SIWAREX WL260 SP-S AB

<b>Possible applications</b>	<ul style="list-style-type: none"> <li>Platform scales</li> <li>Conveyor scales</li> </ul>
<b>Model</b>	Platform load cell
<b>Loads</b>	
Rated load $E_{\max}$ .	<ul style="list-style-type: none"> <li>50 kg (110.23 lb)</li> <li>100 kg (220.46 lb)</li> <li>200 kg (440.92 lb)</li> <li>500 kg (1102.31 lb)</li> </ul>
Minimum initial loading $E_{\min}$	0 % $E_{\max}$
Maximum working load $L_U$	150 % $E_{\max}$
Ultimate load $L_d$	300 % $E_{\max}$
Maximum lateral load $AL_{lq}$	100 % $E_{\max}$
<b>Measurement characteristic values</b>	
Rated measuring path $h_n$ at $E_{\max}$	< 1.22 mm (0.05 inch)
Rated characteristic value $C_n$	$2.0 \pm 0.2$ mV/V
Tolerance $D_0$ of zero signal	$\pm 2$ % $C_n$
Max. load cell verification interval $n_C$	3 000
Min. load cell verification interval $V_{\min}$	$E_{\max}/10\ 000$
Combined error $F_{\text{comb}}$	$\pm 0.02$ % $C_n$
Repeatability $F_v$	$\pm 0.017$ % $C_n$
Creep error $F_{cr}$	$\pm 0.02$ % $C_n$
• 30 min	$\pm 0.02$ % $C_n$
Temperature effect	
• Zero signal $T_{K0}$	0.017 % $C_n/5$ K
• Characteristic value $T_{Kc}$	0.014 % $C_n/5$ K
<b>Electrical characteristic values</b>	
Recommended reference volt. $U_{ref}$	5 ... 12 V DC
Input resistance $R_e$	$409 \Omega \pm 6 \Omega$
Output resistance $R_a$	$350 \Omega \pm 3 \Omega$
Insulation resistance $R_{is}$	5 000 M $\Omega$ at 50 V DC

### Connection and ambient conditions

Sensor material (DIN)	Aluminum
Maximum tightening torque of the fixing screws	35 ... 40 Nm
<b>Function</b>	<b>Color</b>
• EXC + (supply +)	Red
• EXC - (supply -)	Black
• SIG + (measured signal +)	Green
• SIG - (measured signal -)	White
• Sense + (sensor line +)	Blue
• Sense - (sensor line -)	Brown
• Shield	Transparent
Rated temperature range $B_{Tn}$	-10 ... +40 °C (14 ... 104 °F)
Operating temperature range $B_{Tu}$	-35 ... +65 °C (-31 ... +149 °F)
Storage temperature range $B_{Ts}$	-35 ... +65 °C (-31 ... +149 °F)
Degree of protection according to EN 60529; IEC 60529	IP65

### Certificates and approvals

Accuracy class according to OIML R60	C3 <sup>1)</sup>
--------------------------------------	------------------

<sup>1)</sup> OIML type approval for SIWAREX WL260 SP-S AB available soon

### Selection and Ordering data

Selection and Ordering data	Order No.
<b>Load cell, type WL260 SP-S AB</b>	<b>7MH5103-</b>
Connecting cable 3 m (9.84 ft)	<b>D 0 0</b>
<b>Rated load</b>	
• 50 kg (110.23 lb)	<b>2 P</b>
• 75 kg (165.35 lb)	<b>2 S</b>
• 100 kg (220.46 lb)	<b>3 A</b>
• 150 kg (330.69 lb)	<b>3 E</b>
• 200 kg (440.92 lb)	<b>3 G</b>
• 500 kg (1102.31 lb)	<b>3 P</b>

### Dimensional drawings

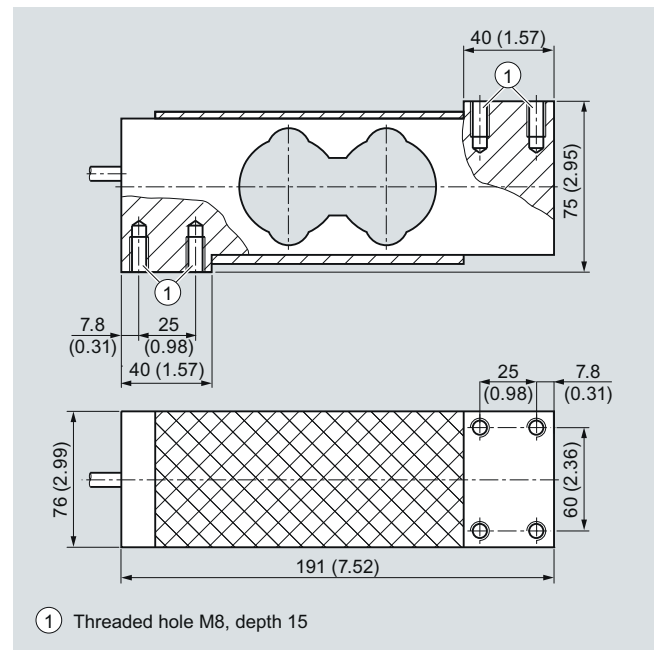

SIWAREX WL260 SP-S AB load cell, dimensions in mm ( inch)

# Load cells

## SIWAREX WL200-SIWAREX WL260 SP-S SA

### Load cell

#### Overview



The load cell is suitable for small to medium platform scales with one load cell (max. platform size 400 x 400 mm (15.75 x 15.75 inch)) as well as for use in medium accuracy weighing machines of Class III with a max. verification interval  $n_{\max} = 3\ 000d$

It is made of stainless steel and therefore also suitable for use in harsh environments.

#### Design

The measuring element is hermetically sealed and has a calibrated output current.

#### Technical specifications

##### SIWAREX WL260 SP-S SA

<b>Possible applications</b>	<ul style="list-style-type: none"> <li>Platform scales</li> <li>Small conveyor scales</li> </ul>
<b>Model</b>	Platform load cell
<b>Loads</b>	
Rated load $E_{\max}$	<ul style="list-style-type: none"> <li>5 kg (11.02 lb)</li> <li>10 kg (22.05 lb)</li> <li>20 kg (44.09 lb)</li> <li>50 kg (110.23 lb)</li> <li>100 kg (220.46 lb)</li> <li>200 kg (440.92 lb)</li> </ul>
Minimum initial loading $E_{\min}$	0 % $E_{\max}$
Maximum working load $L_U$	150 % $E_{\max}$
Ultimate load $L_d$	300 % $E_{\max}$
Maximum lateral load $L_{lq}$	100 % $E_{\max}$
<b>Measurement characteristic values</b>	
Rated measuring path $h_n$ at $E_{\max}$	$0.27 \pm 0.05$ mm ( $0.01 \pm 0.002$ inch)
Rated characteristic value $C_n$	$2.0 \pm 0.2$ mV/V
Tolerance $D_0$ of zero signal	$< \pm 1.0$ % $C_n$
Max. load cell verification interval $n_{lc}$	3 000
Min. load cell verification interval $V_{\min}$	$E_{\max}/7\ 500$
Combined error $F_{\text{comb}}$	$\pm 0.02$ % $C_n$
Repeatability $F_v$	$\pm 0.017$ % $C_n$
Creep error $F_{cr}$	
• 30 min	$\pm 0.02$ % $C_n$
Temperature effect	
• Zero signal $T_{K0}$	0.017 % $C_n/5$ K
• Characteristic value $T_{Kc}$	0.014 % $C_n/5$ K

#### Electrical characteristic values

Recommended reference voltage $U_{\text{ref}}$	5 ... 12 V DC
Input resistance $R_e$	$383 \Omega \pm 6 \Omega$
Output resistance $R_a$	$351 \Omega \pm 3 \Omega$
Insulation resistance $R_{is}$	5 000 M $\Omega$ at 50 V DC

#### Connection and ambient conditions

Sensor material (DIN)	Stainless steel
Maximum tightening torque of the fixing screws	
• $E_{\max} = 3, 5, 10, 20, 50, 100$ kg (6.61, 11.02, 22.05, 44.09, 110.23, 220.46 lb)	14 Nm
• $E_{\max} = 200$ kg (440.92 lb)	16 Nm
<b>Function</b>	<b>Color</b>
• EXC + (supply +)	Green
• EXC - (supply -)	Black
• SIG + (measured signal +)	White
• SIG - (measured signal -)	Red
• Sense + (sensor line +)	Yellow
• Sense - (sensor line -)	Blue
• Shield	Transparent
Rated temperature range $B_{Tn}$	-10 ... +40 °C (14 ... 104°F)
Operating temperature range $B_{Tu}$	-35 ... +65 °C (-31 ... +149 °F)
Storage temperature range $B_{Ts}$	-40 ... +70 °C (-40 ... +158 °F)
Degree of protection according to EN 60529; IEC 60529	IP67

#### Certificates and approvals

Accuracy class according to OIML R60	C3
--------------------------------------	----

#### Selection and Ordering data

	Order No.
<b>Load cell, type WL260 SP-S SA</b>	<b>7MH5104-</b>
Legal-for-trade according to OIML R60 up to 3 000d, connecting cable 3 m (9.84 ft)	<b>D 0</b>
<b>Rated load</b>	
• 5 kg (11.02 lb)	<b>1 P</b>
• 10 kg (22.05 lb)	<b>2 A</b>
• 20 kg (44.09 lb)	<b>2 G</b>
• 50 kg (110.23 lb)	<b>2 P</b>
• 100 kg (220.46 lb)	<b>3 A</b>
• 200 kg (440.92 lb)	<b>3 G</b>
<b>Explosion protection</b>	
Without	<b>0</b>
Explosion protection for zones 0, 1, 2, 20, 21, 22	<b>1</b>

### Dimensional drawings

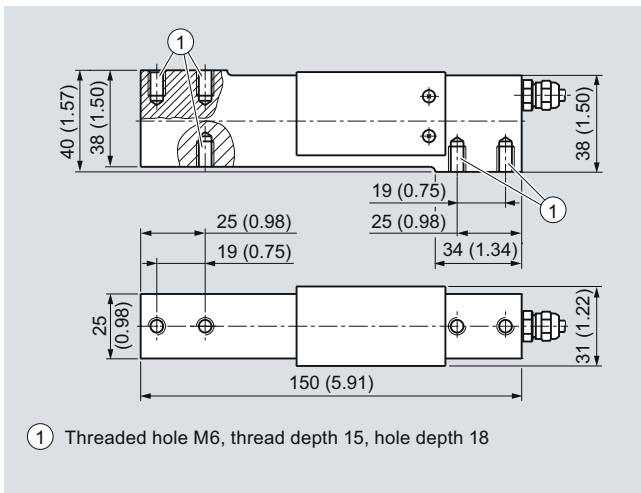

SIWAREX WL 260 SP-S SA load cell, dimensions in mm (inch)

# Load cells

## SIWAREX WL200-SIWAREX WL250 ST-S SA

### Load cell

#### Overview



The load cell is ideal for use in tank weighing, hybrid scales or suspended container weighing. It is made of stainless steel and therefore also suitable for use in harsh environments.

#### Design

The measuring element is hermetically sealed and has a calibrated output current.

#### Technical specifications

##### SIWAREX WL250 ST-S SA

<b>Possible applications</b>	<ul style="list-style-type: none"> <li>• Tension and pressure applications</li> <li>• Suspended scales</li> <li>• Container weighers</li> <li>• Hybrid scales</li> </ul>
<b>Model</b>	S-type
<b>Loads</b>	
Rated load $E_{max}$	<ul style="list-style-type: none"> <li>• 50 kg (110.23 lb)</li> <li>• 100 kg (220.46 lb)</li> <li>• 250 kg (551.16 lb)</li> <li>• 500 kg (1102.31 lb)</li> <li>• 1 t (0.98 tn. L.)</li> <li>• 2.5 t (2.46 tn. L.)</li> <li>• 5 t (4.92 tn. L.)</li> <li>• 10 t (9.84 tn. L.)</li> </ul>
Minimum initial loading $E_{min}$	0 % $E_{max}$
Maximum working load $L_u$	150 % $E_{max}$
Ultimate load $L_d$	300 % $E_{max}$
Maximum lateral load $L_{lq}$	100 % $E_{max}$

#### Measurement characteristic values

Rated measuring path $h_n$ at $E_{max}$	
• $E_{max} = 50, 100$ kg (110.23, 220.46 lb)	0.18 mm (0.01 inch)
• $E_{max} = 250, 500$ kg (551.16, 1102.31 lb)	0.24 mm (0.01 inch)
• $E_{max} = 1$ t (0.98 tn. L.)	0.37 mm (0.01 inch)
• $E_{max} = 2.5, 5$ t (2.46, 4.92 tn. L.)	0.8 mm (0.03 inch)
• $E_{max} = 10$ t (9.84 tn. L.)	0.57 mm (0.02 inch)
Rated characteristic value $C_n$	$3.0 \pm 0.008$ mV/V
Tolerance $D_O$ of zero signal	$< \pm 1.0$ % $C_n$
Max. load cell verification interval $n_{lc}$	3 000
Min. load cell verification interval $V_{min}$	
• $E_{max} = 50, 100$ kg (110.23, 220.46 lb)	$E_{max}/7$ 000
• $E_{max} = 0.25, 0.5, 1, 2.5$ t (0.25, 0.49, 0.98, 2.46 tn. L.)	$E_{max}/10$ 000
• $E_{max} = 5, 10$ t (4.92, 9.84 tn. L.)	$E_{max}/12$ 000
Combined error $F_{comb}$	$\pm 0.02$ % $C_n$
Repeatability $F_V$	$\pm 0.02$ % $C_n$
Creep error $F_{cr}$	
• 30 min	$\pm 0.02$ % $C_n$
Temperature effect	
• Zero signal $T_{K0}$	0.017 % $C_n/5$ K
• Characteristic value $T_{KC}$	0.014 % $C_n/5$ K

#### Electrical characteristic values

Recommended reference voltage $U_{ref}$	5 ... 12 V DC
Input resistance $R_e$	$430 \Omega \pm 4 \Omega$
Output resistance $R_a$	$350 \Omega \pm 3.5 \Omega$
Insulation resistance $R_{is}$	5 000 M $\Omega$ at 50 V DC

#### Connection and ambient conditions

Sensor material (DIN)	Stainless steel
Maximum tightening torque of the fixing screws	
• $E_{max} = 3, 5, 10, 20, 50, 100$ kg (6.61, 11.02, 22.05, 44.09, 110.23, 220.46 lb)	14 Nm
• $E_{max} = 200$ kg (440.92 lb)	16 Nm
<b>Function</b>	<b>Color</b>
• EXC + (supply +)	Red
• EXC - (supply -)	Black
• SIG + (measured signal +)	Green
• SIG - (measured signal -)	White
• Shield	Transparent
Rated temperature range $B_{tn}$	-10 ... +40 °C (14 ... 104 °F)
Operating temperature range $B_{tu}$	-35 ... +65 °C (-31 ... +149 °F)
Storage temperature range $B_{ts}$	-35 ... +65 °C (-31 ... +149 °F)
Degree of protection according to EN 60529; IEC 60529	IP67

#### Certificates and approvals

Accuracy class according to OIML R60	C3
--------------------------------------	----

# Load cells

## SIWAREX WL200-SIWAREX WL250 ST-S SA

Load cell

## Selection and Ordering data

Order No.

## Load cell type WL250 ST-S SA

7MH5105-

Legal-for-trade according to OIML R60 up to 3 000d,  
connecting cable 6 m (19.69 ft)

D 0

## Rated load

- 50 kg (110.23 lb)
- 100 kg (220.46 lb)
- 250 kg (551.16 lb)
- 500 kg (1102.31 lb)
- 1 t (0.98 tn. L.)
- 2.5 t (2.46 tn. L.)
- 5 t (4.92 tn. L.)
- 10 t (9.84 tn. L.)

2 P  
3 A  
3 H  
3 P  
4 A  
4 H  
4 P  
5 A

## Explosion protection

Without

0

Explosion protection for zones 0, 1, 2, 20, 21, 22

1

## Dimensional drawings

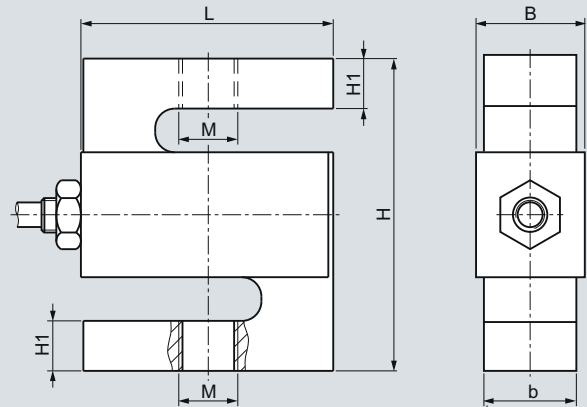

Rated load [kg]	L	H	b	B	M	H1
50 ... 100	50.8 (2.00)	63.5 (2.50)	12.7 (0.49)	16.08 (0.63)	M8	10.16 (0.40)
250 ... 500	50.8 (2.00)	63.5 (2.50)	19.05 (0.75)	22.43 (0.88)	M12	10.16 (0.40)

Rated load [t]	L	H	b	B	M	H1
1	50.8 (2.00)	63.5 (2.50)	25.4 (1.00)	28.78 (1.13)	M12	10.16 (4.00)
2.5	50.8 (2.00)	101.6 (4.00)	25.4 (1.00)	28.78 (1.13)	M20 x 1.5	15.24 (0.60)
5.0	76.2 (3.00)	101.6 (4.00)	25.4 (1.00)	28.78 (1.13)	M20 x 1.5	20 (0.79)
10	127 (5.00)	177.8 (7.00)	50.8 (2.00)	54.18 (2.13)	M30 x 2	39.9 (1.57)

SIWAREX WL250 ST-S SA load cell, dimensions in mm (inch)

3

# Load cells

## SIWAREX WL200-SIWAREX WL230 BB-S SA

### Load cell

#### Overview



The bending beam load cell is particularly suitable for use in small-scale container and platform scales.

#### Design

The measuring element is a double bending beam made of stainless steel to which 4 strain gauges are applied.

The strain gauges are arranged so that two are stretched and two are compressed.

Under the influence of the load acting in the measuring direction, the spring bodies and therefore the friction-locked strain gauges are elastically deformed. This generates a measuring signal voltage that is proportional to the load.

#### Technical specifications

##### SIWAREX WL230 BB-S SA

<b>Possible applications</b>	<ul style="list-style-type: none"> <li>• Container weighers</li> <li>• Conveyor scales</li> <li>• Platform scales</li> </ul>
<b>Model</b>	Bending load cell
<b>Loads</b>	
Rated load $E_{max}$	<ul style="list-style-type: none"> <li>• 10 kg (22.05 lb)</li> <li>• 20 kg (44.09 lb)</li> <li>• 50 kg (110.23 lb)</li> <li>• 100 kg (220.46 lb)</li> <li>• 200 kg (440.92 lb)</li> <li>• 350 kg (771.62 lb)</li> <li>• 500 kg (1102.3 lb)</li> </ul>
Minimum initial loading $E_{min}$	0 % $E_{max}$
Maximum working load $L_u$	150 % $E_{max}$
Ultimate load $L_d$	300 % $E_{max}$
Max. safe side load $L_{Iq}$	100 % $E_{max}$

#### Measurement characteristic values

Rated measuring path $h_n$ at $E_{max}$	0.3 mm (0.01 inch)
Rated characteristic value $C_n$	$2.0 \pm 0.02$ % mV/V
Tolerance $D_O$ of zero signal	$< \pm 1.0$ % $C_n$
Maximum load cell verification interval $n_{LC}$	3 000 <sup>1)</sup>
Minimum load cell verification interval $V_{min}$	$E_{max}/15\ 000$
Minimum application range $R_{min(LC)}$	30 %
Combined error $F_{comb}$	$\leq 0.02$ % $C_n$
Repeatability $F_v$	$\leq 0.017$ % $C_n$
Return of zero signal	Not applicable
Creep error $F_{cr}$	
• 30 min	$\leq \pm 0.02$ % $C_n$
Temperature effect	
• Zero signal $T_{K0}$	$\leq \pm 0.017$ % $C_n/5$ K
• Characteristic value $T_{KC}$	$\leq \pm 0.014$ % $C_n/5$ K

#### Electrical characteristic values

Recommended reference voltage $U_{ref}$	5 ... 10 V DC
Input resistance $R_e$	$460 \Omega \pm 50 \Omega$
Output resistance $R_a$	$350 \Omega \pm 3.5 \Omega$
Insulation resistance $R_{is}$	5 000 M $\Omega$ at 50 V DC
Current calibration	Standard

#### Connection and ambient conditions

Sensor material (DIN)	Stainless steel
Max. tightening torque of the fixing screws	
• $E_{max} = 10, 20, 50, 100, 200$ kg (22.05, 44.09, 110.23, 220.46, 440.92 lb)	23 Nm <sup>2)</sup>
• $E_{max} = 350, 500$ kg (771.62, 1102.31 lb)	70 Nm <sup>2)</sup>
<b>Function</b>	<b>Color</b>
• EXC + (supply +)	Green
• EXC - (supply -)	Black
• SIG + (measured signal +)	White
• SIG - (measured signal -)	Red
• Shield	Transparent
Rated temperature range $B_{tn}$	-10 ... +40 °C (14 ... 104 °F)
Operating temperature range $B_{tu}$	-35 ... +65 °C (-31 ... +149 °F)
Storage temperature range $B_{ts}$	-35 ... +65 °C (-31 ... +149 °F)
Degree of protection according to EN 60529; IEC 60529	IP68

#### Certificates and approvals

Accuracy class according to OIML R60	C3
--------------------------------------	----

<sup>1)</sup> Higher accuracy class available on request

<sup>2)</sup> The tightening torque should be selected in accordance with the strength grade of the screws.

# Load cells

## SIWAREX WL200-SIWAREX WL230 BB-S SA

Load cell

**Selection and Ordering data**

Order No.

**Load cell type WL230 BB-S SA****7MH5106-**

Legal-for-trade according to OIML R60 up to 3 000d,  
connecting cable 3 m (9.84 ft)

■	■	D	0	■
---	---	---	---	---

**Rated load**

- 10 kg (22.05 lb)
- 20 kg (44.09 lb)
- 50 kg (110.23 lb)
- 100 kg (220.46 lb)
- 200 kg (440.92 lb)
- 350 kg (771.62 lb)
- 500 kg (1102.31 lb)

2	A		
2	G		
2	P		
3	A		
3	G		
3	L		
3	P		

**Explosion protection**

Without

0

Explosion protection for zones 0, 1, 2, 20, 21, 22

1

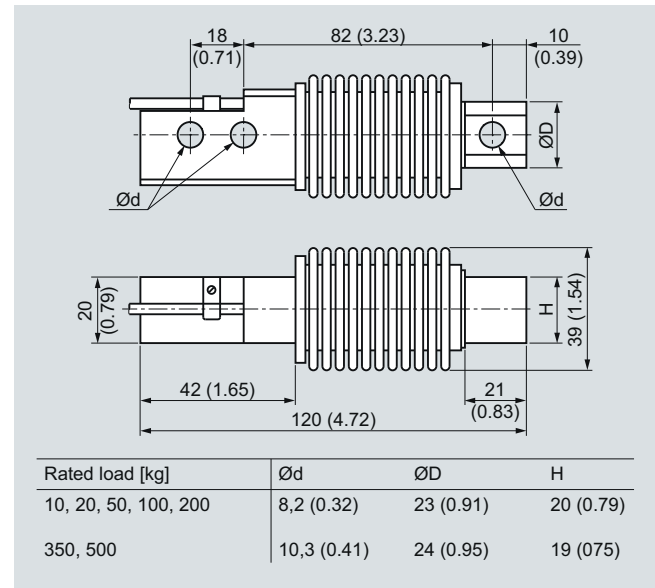
**Dimensional drawings**

SIWAREX WL230 BB-S SA load cell, dimensions in mm (inch)

3

# Load cells

## SIWAREX WL200-SIWAREX WL230 BB-S SA

### Base plate with overload protection

#### Overview



The base plate with integral overload protection for load cells of the SIWAREX WL230 BB-S SA series ensures easy, correct installation of the load cell.

#### Design

The integrated overload protection ensures that the load cell is not damaged by static overloading with vertical forces of up to 5 kN.

The load cells can be installed on the base plate and aligned even before final installation of the scales. This ensures that the permissible spring excursion of the load cell is precisely set, up to contact with the overload protection.

The load cell is not included in the scope of delivery of the base plate with overload protection.

#### Dimensional drawings

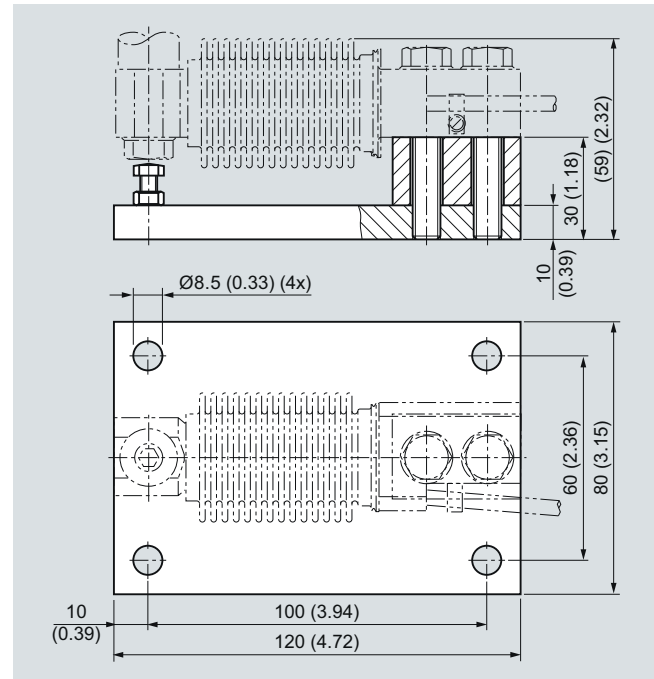

Elastomer bearing and base plate with overload protection for SIWAREX WL230 BB-S SA load cells, 10 ... 200 kg (22.05 ... 440.92 lb), dimensions in mm (inch)

#### Selection and Ordering data

Order No.

##### Base plate with overload protection

For load cells of the SIWAREX WL230 BB-S SA series

Material: Stainless steel

For load cells with a rated load of<sup>1)2)</sup>:

- 10 ... 200 kg (22.05 ... 440.92 lb) D) **7MH4133-3DG11**
- 350 kg (771.62 lb), 500 kg (1102.31 lb) **On request**

<sup>1)</sup> The load cell is not included in the scope of delivery.

<sup>2)</sup> It is highly recommendable to use a grounding cable (7MH3701-1AA1) in order to protect the load cell.

D) Subject to export regulations AL: N, ECCN: EAR99H.



### Overview



The self-centering elastomer bearing for load cells of the SIWAREX WL230 BB-S SA series is the ideal load introduction element for scales without guide elements. It serves to damp vibrations and shocks.

### Design

Elastomer bearings are rubber-metal composites made of neoprene and stainless steel. They ensure large spring excursions (i.e. a high degree of damping) despite small dimensions.

If the load support is displaced by more than 4 mm (0.16 inch) in the horizontal direction, the design of the load support must include measures for restricting sideways play (e. g. limit stops).

In combination with the base plate and integral overload protection, it is ensured that the load cell is not damaged by static overloading with vertical forces of up to 5 kN.

The load cell and the base plate are not included in the scope of delivery of the elastomer bearing.

### Dimensional drawings

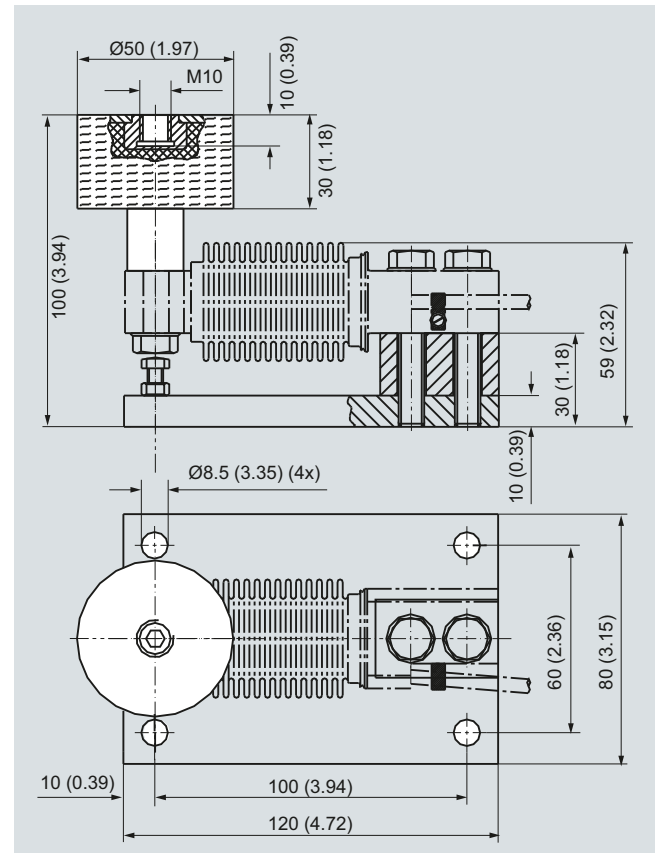

Elastomer bearings for SIWAREX WL230 BB-S SA load cells, 10 kg to 200 kg (22.05 lb bis 440.92 lb), dimensions in mm (inch)

### Selection and Ordering data

Order No.

#### Elastomer bearing

For load cells of the SIWAREX WL230 BB-S SA series

Material: Stainless steel

For load cells with a rated load of<sup>1)2)</sup>:

- 10 ... 50 kg (22.05 ... 110.23 lb) D) **7MH4133-2KE11**
- 10 ... 200 kg (22.05 ... 440.92 lb) D) **7MH4133-3DE11**
- 500 kg (1102.31 lb) **On request**

<sup>1)</sup> The load cell is not included in the scope of delivery.

<sup>2)</sup> It is highly recommendable to use a grounding cable (7MH3701-1AA1) in order to protect the load cell.

D) Subject to export regulations AL: N, ECCN: EAR99H.

# Load cells

## SIWAREX WL200-SIWAREX WL230 BB-S SA

### Compact mounting unit

#### Overview

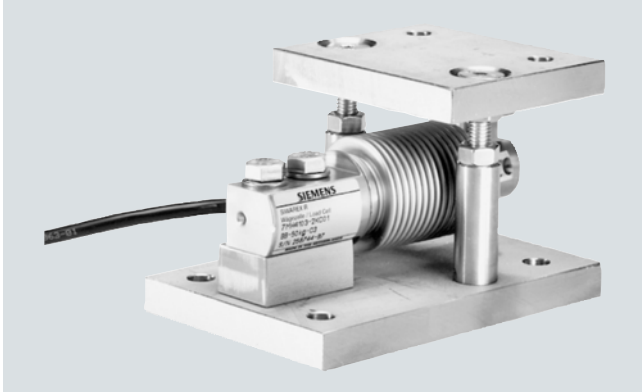

The self-aligning compact mounting unit for SIWAREX WL230 BB-S SA load cells is particularly suitable for implementation in small-scale container, platform and roller table scales.

#### Design

The compact mounting unit comprises a base plate and a top plate, a self-aligning bolt, two countersunk screws and overload protection.

The top plate is aligned and fixed above the base plate with the two countersunk screws. This results in a stable unit. The height of the top plate can be adjusted so that it is two millimeters above the installation height with load cell.

In this state the compact mounting unit serves as an installation aid and can be used as a dummy for light installation jobs.

Prior to installation, the load cell is inserted with the self-aligning bolt into the compact mounting unit. Then the complete unit is installed in the scales. As the result, the load bearing implement and the mounting units are aligned. The load cells are not yet loaded.

Finally the load bearing implement is lowered by undoing two hex nuts under the top plate. The weight now rests on the load cells.

In this state the load cell and the pressure pieces together form a self-centering unit. The compact mounting unit permits sideways displacement of the top plate, and thus of the load support, by up to 1.5 mm (0.06 inch).

The overload protection is set so that the load cell cannot be loaded beyond the limit load.

#### Dimensional drawings

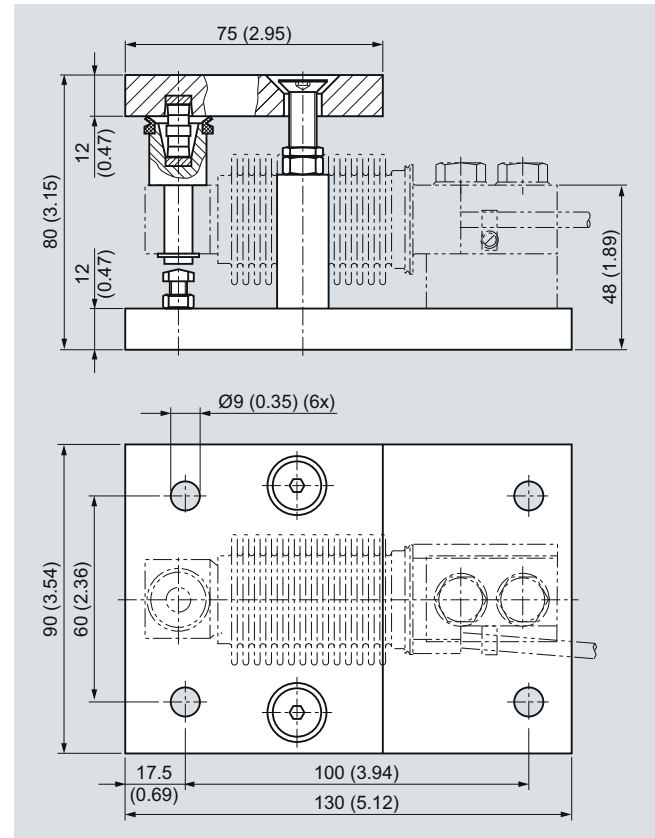

Compact mounting unit for SIWAREX WL230 BB-S SA load cells, dimensions in mm (inch)

#### Selection and Ordering data

Order No.

##### Compact mounting unit

For load cells of the SIWAREX WL230 BB-S SA series

Material: Stainless steel

For load cells with a rated load of<sup>1)2)</sup>:

- 10 ... 200 kg (22.05 ... 440.92 lb) D) **7MH4133-3DC11**

<sup>1)</sup> The load cell is not included in the scope of delivery.

<sup>2)</sup> It is highly recommendable to use a grounding cable (7MH3701-1AA1) in order to protect the load cell.

D) Subject to export regulations AL: N, ECCN: EAR99H.

# Load cells

## SIWAREX WL200-SIWAREX WL230 SB-S SA

Load cell

### Overview



The shear beam load cell is particularly suitable for implementation in container, overhead rail conveyor and platform scales.

### Design

The measuring element is a shear tension spring made of stainless steel to which strain gauges are applied. The strain gauges are arranged at 45° to the longitudinal axis on the side of the spring body and are therefore subject to shear forces. Under the influence of the load acting in the measuring direction, the spring bodies and therefore the friction-locked strain gauges are elastically deformed. This generates a measuring signal voltage that is proportional to the load.

### Technical specifications

#### SIWAREX WL230 SB-S SA

<b>Possible applications</b>	<ul style="list-style-type: none"> <li>• Container weighers</li> <li>• Conveyor scales</li> <li>• Overhead rail scales</li> <li>• Platform scales</li> </ul>
<b>Model</b>	Shear beam
<b>Loads</b>	
Rated load $E_{\max}$	<ul style="list-style-type: none"> <li>• 0.5 t (0.49 tn. L.)</li> <li>• 1 t (0.98 tn. L.)</li> <li>• 2 t (1.97 tn. L.)</li> <li>• 5 t (4.92 tn. L.)</li> </ul>
Minimum initial loading $E_{\min}$	0 % $E_{\max}$
Maximum working load $L_u$	150 % $E_{\max}$
Ultimate load $L_d$	300 % $E_{\max}$
Maximum lateral load $L_{lq}$	100 % $E_{\max}$

### Measurement characteristic values

Rated measuring path $h_n$ at $E_{\max}$	
• $E_{\max} = 0.5$ t (0.49 tn. L.)	0.13 mm (0.005 inch)
• $E_{\max} = 1$ t (0.98 tn. L.)	0.21 mm (0.008 inch)
• $E_{\max} = 2$ t (1.97 tn. L.)	0.29 mm (0.011 inch)
• $E_{\max} = 5$ t (4.92 tn. L.)	0.38 mm (0.014 inch)
Rated characteristic value $C_n$	$2.0 \pm 0.02$ % mV/V
Tolerance $D_O$ of zero signal	$\leq \pm 1.0$ % $C_n$
Maximum load cell verification interval $n_{LC}$	3 000
Min. load cell verification interval $V_{\min}$	
• $E_{\max} = 0.5$ t (0.49 tn. L.)	$E_{\max}/10\,000$
• $E_{\max} = 1, 2, 5$ t (0.98, 1.97, 4.92 tn. L.) <sup>1)</sup>	$E_{\max}/15\,000$
Minimum application range $R_{\min(LC)}$	
• $E_{\max} = 0.5$ t (0.49 tn. L.)	30 %
• $E_{\max} = 1, 2, 5$ t (0.98, 1.97, 4.92 tn. L.)	20 %
Combined error $F_{\text{comb}}$	$\pm 0.02$ % $C_n$
Repeatability $F_V$	$\pm 0.02$ % $C_n$
Creep error $F_{Cr}$	
30 min	$\leq \pm 0.02$ % $C_n$
Temperature effect	
• Zero signal $T_{K0}$	$\leq \pm 0.023$ % $C_n/5$ K
• Characteristic value $T_{Kc}$	$\leq \pm 0.017$ % $C_n/5$ K

### Electrical characteristic values

Recommended reference voltage $U_{\text{ref}}$	5 ... 12 V DC
Input resistance $R_e$	$1\,000 \Omega \pm 10 \Omega$
Output resistance $R_a$	$1\,004 \Omega \pm 5 \Omega$
Insulation resistance $R_{is}$	5 000 M $\Omega$ at 50 V DC

### Connection and ambient conditions

Sensor material (DIN)	Stainless steel
Maximum tightening torque of the fixing screws	
• $E_{\max} = 0.5, 1, 2$ t (0.49, 0.98, 1.97 tn. L.)	150 Nm <sup>2)</sup>
• $E_{\max} = 5$ t (4.92 tn. L.)	550 Nm <sup>2)</sup>
<b>Function</b>	<b>Color</b>
• EXC + (supply +)	Green
• EXC - (supply -)	Black
• SIG + (measured signal +)	White
• SIG - (measured signal -)	Red
• Shield	Transparent
Rated temperature range $B_{Tn}$	-10 ... +40 °C (14 ... 104 °F)
Operating temperature range $B_{Tu}$	-35 ... +65 °C (-31 ... +149 °F)
Storage temperature range $B_{Ts}$	-35 ... +65 °C (-31 ... +149 °F)
Degree of protection according to EN 60529; IEC 60529	IP68

### Certificates and approvals

Accuracy class according to OIML R60	C3 <sup>1)</sup>
--------------------------------------	------------------

<sup>1)</sup> OIML type approval for SIWAREX WL230 SB-S SA 5 t (4.92 tn. L.) available soon

<sup>2)</sup> The tightening torque should be selected in accordance with the strength grade of the screws.

# Load cells

## SIWAREX WL200-SIWAREX WL230 SB-S SA

### Load cell

#### Selection and Ordering data

Order No.

#### Load cell type WL230 SB-S SA

7MH5107-

Legal-for-trade acc. to OIML R60 up to 3 000d, connecting cable 3 m (9.84 ft) at 500 kg (1102.31 lb) up to 1 t (0.98 tn. L.), connecting cable 6 m (19.68 ft) at 2 t (1.97 tn. L.) up to 5 t (4.92 tn. L.)

D 0

#### Rated load

- 500 kg (1102.31 lb)
- 1 t (0.98 tn. L.)
- 2 t (1.97 tn. L.)
- 5 t (4.92 tn. L.)<sup>1)</sup>

3 P  
4 A  
4 G  
4 P

#### Explosion protection

Without

0

Explosion protection for zones 0, 1, 2, 20, 21, 22

1

<sup>1)</sup> OIML type approval for SIWAREX WL230 SB-S SA 5 t available soon

#### Dimensional drawings

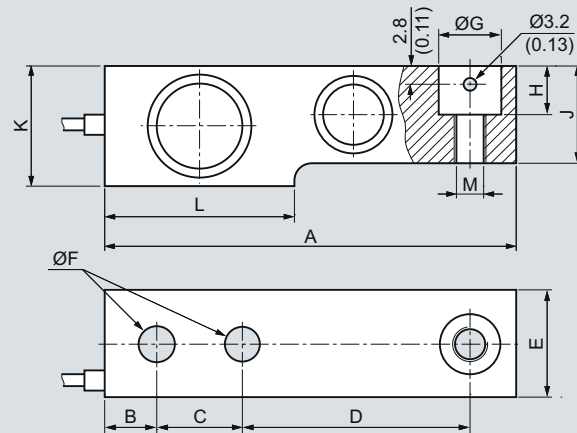

Rated load [t]	A	B	C	D	E	ØF
0.5	130 (5.12)	16 (0.63)	25.4 (1.00)	76 (2.99)	32 (1.26)	13 (0.51)
1	130 (5.12)	16 (0.63)	25.4 (1.00)	76 (2.99)	32 (1.26)	13 (0.51)
2	130 (5.12)	16 (0.63)	25.4 (1.00)	76 (2.99)	32 (1.26)	13 (0.51)
5	172 (6.77)	19 (0.63)	38.1 (1.50)	95 (3.74)	38 (1.50)	20.5 (0.81)
Rated load [t]	ØG	H	J	K	L	M
0.5	20.5 (0.81)	14 (0.55)	26 (1.02)	32 (1.26)	57 (2.24)	M12
1	20.5 (0.81)	14 (0.55)	28 (1.10)	32 (1.26)	57 (2.24)	M12
2	20.5 (0.81)	14 (0.55)	32 (1.26)	36 (1.42)	57 (2.24)	M12
5	30.2 (1.89)	20 (0.79)	40 (1.57)	44 (1.73)	76 (2.99)	M20

SIWAREX WL230 SB-S SA load cell, dimensions in mm (inch)

# Load cells

## SIWAREX WL200-SIWAREX WL230 SB-S SA

### Compact mounting unit

#### Overview

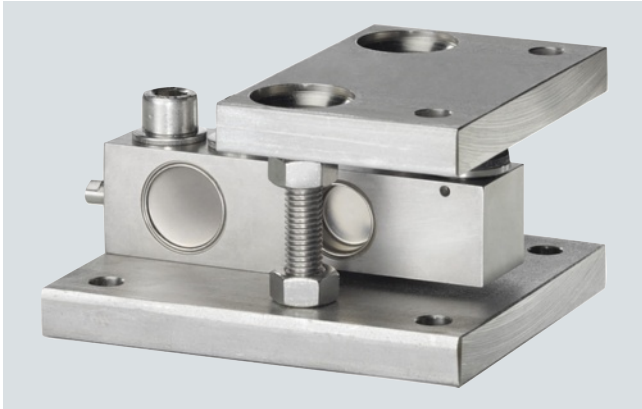

The self-aligning compact mounting unit for SIWAREX WL230 SB-S SA load cells is particularly suitable for implementation in container, platform and roller table scales.

#### Design

The compact mounting unit comprises a base plate and a top plate, a self-aligning bolt and two countersunk screws.

The top plate is aligned and fixed above the base plate with the two countersunk screws. This results in a stable unit. The height of the top plate is adjusted so that it is three millimeters above the installation height with load cell.

In this state the compact mounting unit serves as an installation aid and can be used as a dummy for light installation jobs.

Prior to installation, the load cell is inserted with the self-aligning bolt into the compact mounting unit. Then the complete unit is installed in the scales. As the result, the load bearing implement and the mounting units are aligned. The load cells are not yet loaded.

Finally the load bearing implement is lowered by undoing two hex nuts under the top plate. The weight now rests on the load cells.

In this state the load cell and the pressure pieces together form a self-centering unit. The compact mounting unit permits sideways displacement of the top plate, and hence of the load bearing implement, by up to three mm.

#### Selection and Ordering data

Order No.

##### Compact mounting unit

For load cells of the SIWAREX WL230 SB-S SA series and the rated load

Material: Stainless steel

For load cells with a rated load of<sup>1)2)</sup>:

- 500 kg (1102.31 lb), 1 t (0.98 tn. L.)
- 2 t (1.97 tn. L.)
- 5 t (4.92 tn. L.)

<b>7MH5707-</b>
<b>4</b> ■ <b>A 0 0</b>
<b>A</b>
<b>G</b>
<b>P</b>

<sup>1)</sup> The load cell is not included in the scope of delivery.

<sup>2)</sup> It is highly recommendable to use a grounding cable (7MH3701-1AA1) in order to protect the load cell.

#### Dimensional drawings

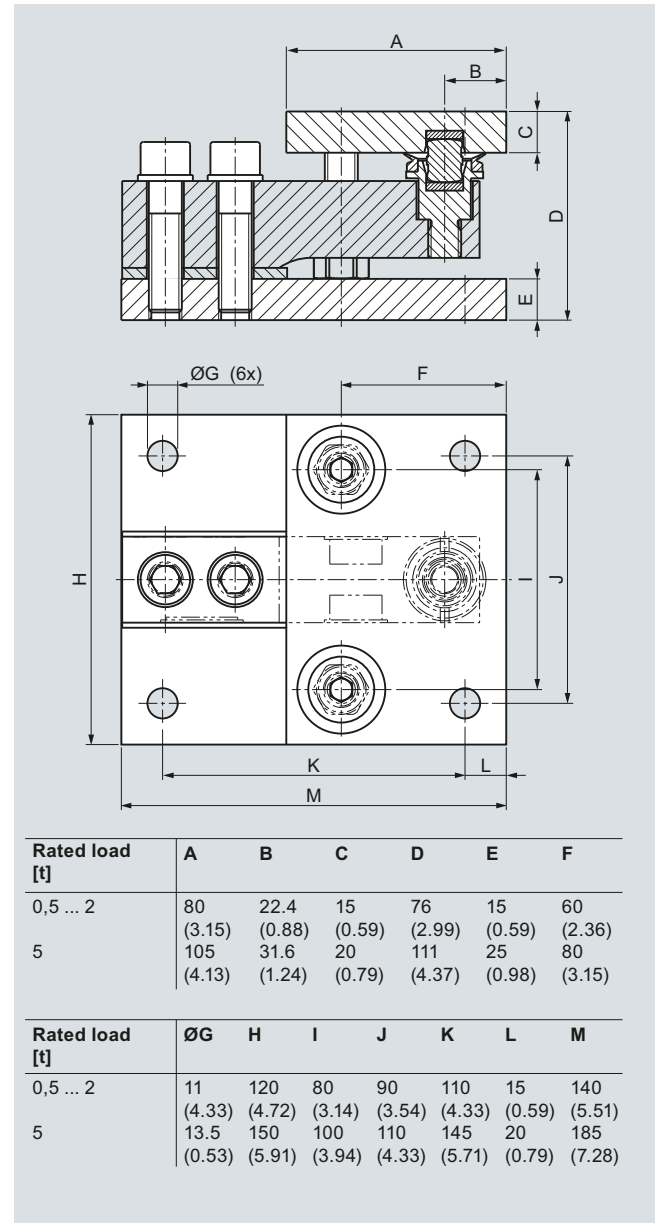

Compact mounting unit for SIWAREX WL230 SB-S SA load cells, dimensions in mm (inch)

# Load cells

## SIWAREX WL200-SIWAREX WL270 CP-S SA

### Load cell

#### Overview



The compression load cell is particularly suitable for implementation in container, hopper and vehicle scales.

#### Design

The measuring element is a solid cylinder made of stainless steel to which 4 strain gauges are applied.

The load which acts centrally in the measuring direction causes the spring bodies and therefore the friction-locked strain gauges to be elastically deformed. This generates a measuring signal voltage that is proportional to the load.

#### Technical specifications

##### SIWAREX WL270 CP-S SA

Possible applications	<ul style="list-style-type: none"> <li>• Container weighers</li> <li>• Overhead rail scales</li> <li>• Vehicle scales</li> </ul>
Model	Compression load cell
Loads	
Rated load $E_{max}$	<ul style="list-style-type: none"> <li>• 10 t (9.84 tn. L.)</li> <li>• 20 t (19.68 tn. L.)</li> <li>• 30 t (29.53 tn. L.)</li> <li>• 50 t (49.21 tn. L.)</li> </ul>
Minimum initial loading $E_{min}$	0 % $E_{max}$
Maximum working load $L_u$	150 % $E_{max}$
Ultimate load $L_d$	300 % $E_{max}$
Maximum lateral load $L_{lq}$	75 % $E_{max}$

#### Measurement characteristic values

Rated measuring path $h_n$ at $E_{max}$	0.5 mm (0.02 inch)
Rated characteristic value $C_n$	$2.0 \pm 0.02$ % mV/V
Tolerance $D_O$ of zero signal	$\leq \pm 1.0$ % $C_n$
Maximum load cell verification interval $n_{LC}$	3 000
Min. load cell verification interval $V_{min}$	
$E_{max} = 10, 20, 50$ t (9.84, 19.68, 49.21 tn. L.)	$E_{max}/10\ 000$
Minimum application range $R_{min(LC)}$	30 %
Combined error $F_{comb}$	$\pm 0.02$ % $C_n$
Creep error $F_{cr}$	
• 30 min	$\leq \pm 0.023$ % $C_n$

#### Electrical characteristic values

Recommended reference voltage $U_{ref}$	5 ... 12 V DC
Input resistance $R_e$	$700 \Omega \pm 7 \Omega$
Output resistance $R_a$	$700 \Omega \pm 7 \Omega$
Insulation resistance $R_{is}$	5 000 M $\Omega$ at 50 V DC
Temperature effect	
• Zero signal $T_{K0}$	$\leq \pm 0.023$ % $C_n/5$ K
• Characteristic value $T_{KC}$	$\leq \pm 0.017$ % $C_n/5$ K

#### Connection and ambient conditions

Sensor material (DIN)	Stainless steel
Function	Color
• EXC + (supply +)	Red
• EXC - (supply -)	Black
• SIG + (measured signal +)	Green
• SIG - (measured signal -)	White
• Shield	Transparent
Rated temperature range $B_{tn}$	-10 ... +40 °C (14 ... 104 °F)
Operating temperature range $B_{tu}$	-35 ... +65 °C (-31 ... +149 °F)
Storage temperature range $B_{ts}$	-35 ... +65 °C (-31 ... +149 °F)
Degree of protection according to EN 60529; IEC 60529	IP68

#### Certificates and approvals

Accuracy class according to OIML R60	C3
--------------------------------------	----

#### Selection and Ordering data

Load cell type WL270 CP-C SA	Order No.
Legal-for-trade according to OIML R60 up to 3 000d, connecting cable 15 m (49.21 ft)	<b>7MH5108-</b>
	<b>D 0</b>
<b>Rated load</b>	
• 10 t (9.84 tn. L.)	<b>5 A</b>
• 20 t (19.68 tn. L.)	<b>5 G</b>
• 30 t (29.63 tn. L.)	<b>5 K</b>
• 50 t (49.21 tn. L.)	<b>5 P</b>
<b>Explosion protection</b>	
Without	<b>0</b>
Explosion protection for zones 0, 1, 2, 20, 21, 22	<b>1</b>

### Dimensional drawings

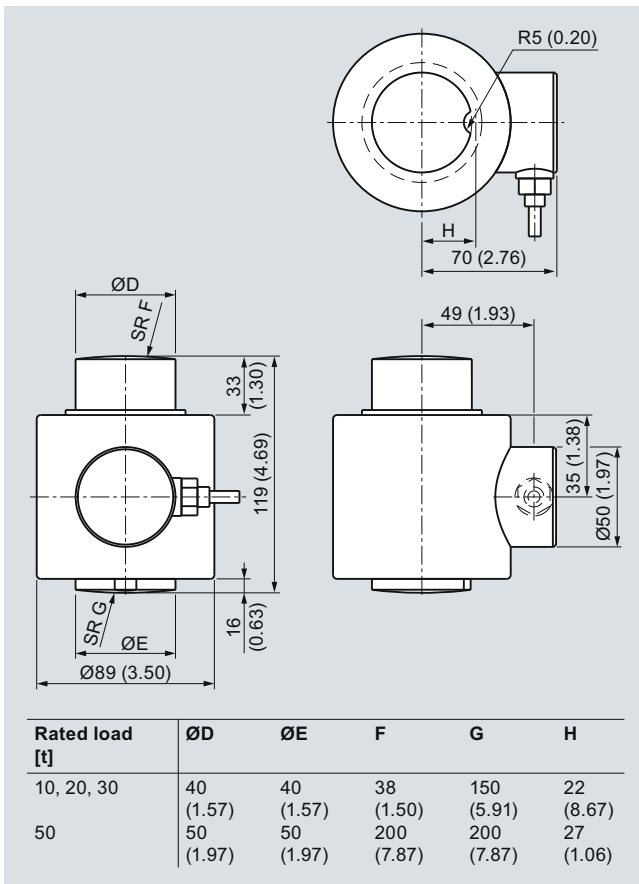

SIWAREX WL270 CP-S SA load cell, dimensions in mm (inch)

# Load cells

## SIWAREX WL200-SIWAREX WL270 CP-S SA

### Pressure pieces and adapter plate

#### Overview



In combination with a pressure piece set and adapter plate the SIWAREX WL270 CP-S SA produces a self-centering self-aligning bearing. This unit is particularly suitable for installation in container, hopper and vehicle scales.

#### Design

The pressure piece set consists of an upper and lower pressure piece. Together with the load cell the pressure piece set forms a self-centering unit with integrated torsion guard. Two adapter plates serve to hold the pressure pieces and round off the unit into a self-aligning bearing. The adapter plates can be bolted by means of the existing holes directly to the load bearing implement.

The self-centering, self-aligning bearing thus formed allows the load bearing implement to follow horizontal displacements (e.g. due to temperature fluctuations). In this case the construction of the self-aligning bearing creates a restoring force which is dependent on the size of the displacement and the applied load.

If the load support is displaced by more than 3 mm (0.12 inch) in the lateral direction, the design of the load support must include measures for restricting sideways play (e.g. stops or guide elements). Lifting of the load support must be prevented by suitable measures provided in the construction of the load bearing implement.

The load cell must be ordered separately.

The adapter plate package item consists of one unit.

#### Selection and Ordering data

Order No.

##### Pressure piece set<sup>1)</sup>

7MH5708-

For the individual installation of load cells from the SIWAREX WL270 CP-S SA series

5 D 0 0

Material: Stainless steel

For load cells with a rated load of<sup>2)3)</sup>

- 10, 20, 30 t (9.84, 19.68, 29.53 tn. L.)
- 50 t (49.21 tn. L.)

K

P

##### Adapter plate

7MH5708-

Adapter for SIWAREX WL270 CP-S SA  
The package item consists of one plate.

5 B 0 0

Material: Stainless steel

For load cells with a rated load of<sup>2)3)</sup>

10 ... 50 t (9.84 ... 49.21 tn. L.)

P

- <sup>1)</sup> The principles of general mechanical engineering and safety must be observed.
- <sup>2)</sup> It is highly recommendable to use a grounding cable (7MH3701-1AA1) in order to protect the load cell.
- <sup>3)</sup> The load cell is not included in the scope of delivery.

#### Dimensional drawings

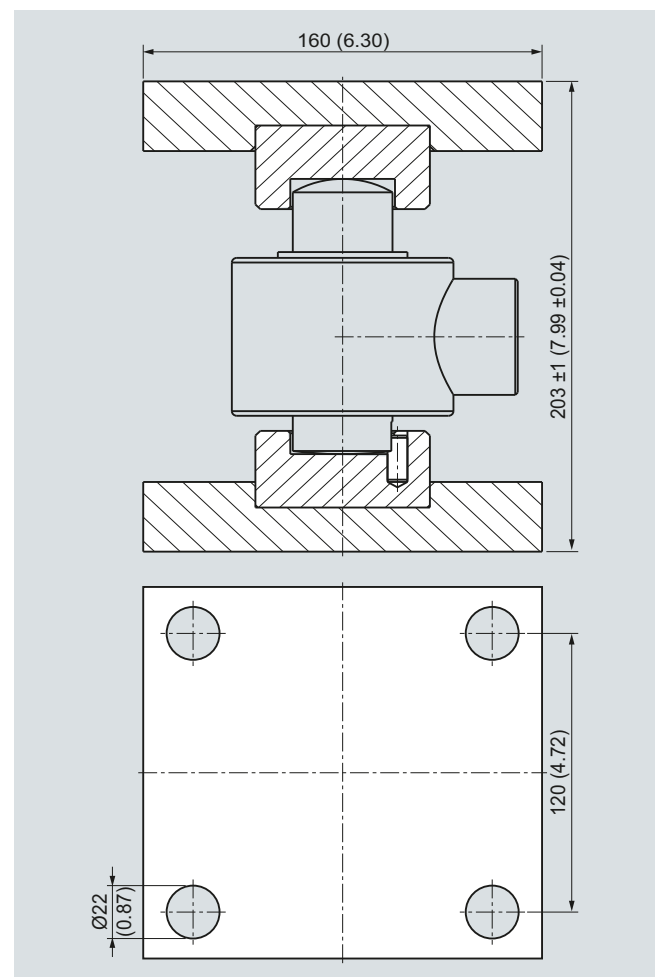

Pressure piece set and Adapter plate for SIWAREX WL270 CP-S SA load cell (mounting condition), dimensions in mm (inch)



# Load cells

## SIWAREX WL200-SIWAREX WL270 CP-S SA

### Compact mounting unit

#### Overview

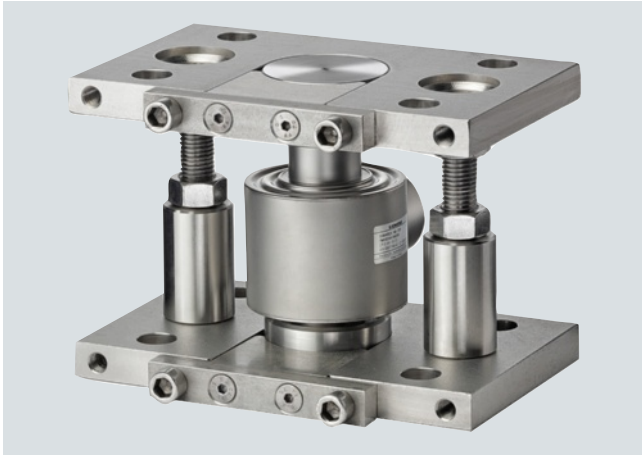

The self-aligning compact mounting unit for SIWAREX WL270 CP-S SA load cells is particularly suitable for implementation in container, platform, vehicle and roller table scales.

#### Design

The compact mounting unit comprises a base plate and a top plate, two pressure pieces, two clamping pieces and two countersunk screws. There are threaded holes in the base plate and top plate for the subsequent flange-fitting of guide elements.

The top plate is aligned and fixed above the base plate with the two countersunk screws. This results in a stable unit. The height of the top plate is adjusted so that it is three millimeters above the installation height with load cell.

Two pressure pieces are used to mount the load cell. They are fastened flush with the head plate and base plate using the clamping pieces.

In this state the compact mounting unit serves as an installation aid and can be used as a dummy for light installation jobs.

Prior to installation, the load cell is inserted into the compact mounting unit. Then the complete unit is installed in the scales. As the result, the load bearing implement and the mounting units are aligned. The load cells are not yet loaded.

Finally the load bearing implement is lowered by undoing two hex nuts under the top plate. The weight now rests on the load cells.

In this state the load cell and the pressure pieces together form a self-centering unit. The compact mounting unit permits sideways displacement of the top plate, and hence of the load bearing implement, by up to three millimeters in all directions. The countersunk screws prevent the load bearing implement from being lifted off or toppling off.

Using the compact mounting unit as an installation aid results in optimum alignment of the load cells. This is essential for the load cells to perform at their best in terms of accuracy.

For maintenance or troubleshooting purposes the load cell can be relieved again by screwing up the hex nuts. Replacement of the load cell is then easy after the clamping pieces are released.

#### Selection and Ordering data

Order No.

##### Compact mounting unit

7MH5708-

For load cells of the SIWAREX WL270 CP-S SA series

5 A 0 0

Material: Stainless steel

For load cells with a rated load of<sup>1)2)</sup>:

- 10, 20, 30 t (9.84, 19.68, 29.53 tn. L.)
- 50 t (49.21 tn. L.)

K

P

<sup>1)</sup> The load cell is not included in the scope of delivery.

<sup>2)</sup> It is highly recommendable to use a grounding cable (7MH3701-1AA1) in order to protect the load cell.

#### Dimensional drawings

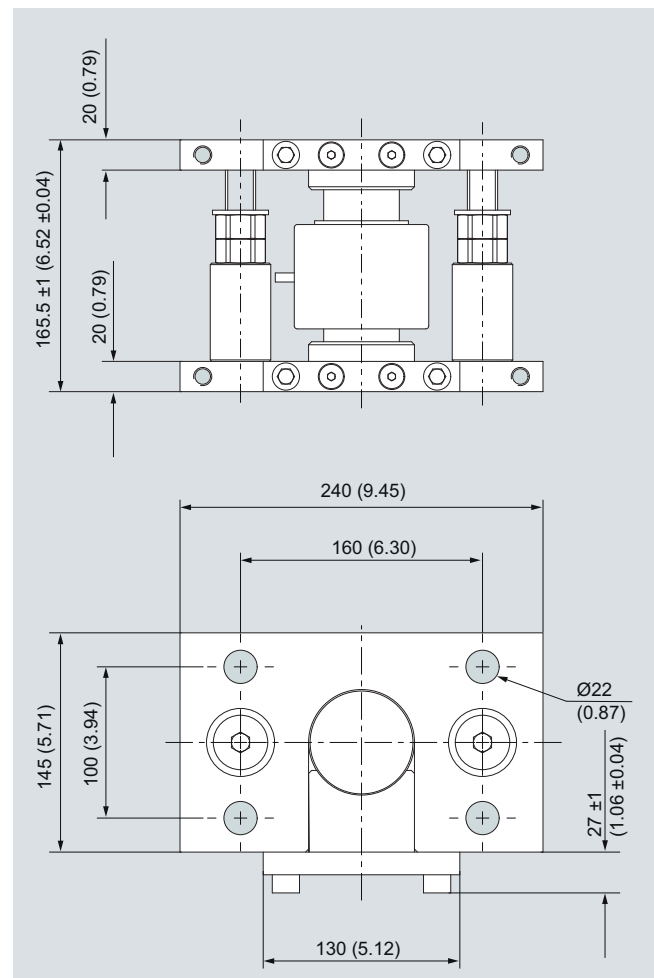

Compact mounting unit for SIWAREX WL270 CP-S SA load cells, dimensions in mm (inch)

# Load cells

## SIWAREX WL200-SIWAREX WL270 CP-S SB

### Load cell

#### Overview



The compression load cell is particularly suitable for implementation in container, hopper and vehicle scales.

#### Design

The measuring element is a solid cylinder made of stainless steel to which 4 strain gauges are applied.

The load which acts centrally in the measuring direction causes the spring bodies and therefore the friction-locked strain gauges to be elastically deformed. This generates a measuring signal voltage that is proportional to the load.

#### Technical specifications

##### SIWAREX WL270 CP-S SB

<b>Possible applications</b>	Container weighers
<b>Model</b>	Compression load cell
<b>Loads</b>	
Rated load $E_{max}$	100 t (98.42 tn. L.)
Minimum initial loading $E_{min}$	0 % $E_{max}$
Maximum working load $L_u$	150 % $E_{max}$
Ultimate load $L_d$	300 % $E_{max}$
Maximum lateral load $L_{lq}$	10 % $E_{max}$
<b>Measurement characteristic values</b>	
Rated measuring path $h_n$ at $E_{max}$	0.36 mm (0.01 inch)
Rated characteristic value $C_n$	2,0 ± 0,02 % mV/V
Tolerance $D_o$ of zero signal	≤ ± 1.0 % $C_n$
Maximum load cell verification interval $n_{LC}$	3 000
Min. load cell verification interval $V_{min}$	
$E_{max} = 100$ t (98.42 tn. L.)	$E_{max}/9\ 000$
Minimum application range $R_{min(LC)}$	33 %
Combined error $F_{comb}$	± 0.02 % $C_n$
Repeatability $F_v$	± 0.02 % $C_n$
Creep error $F_{cr}$	
• 30 min	≤ ± 0.023 % $C_n$
Temperature effect	
• Zero signal $T_{K0}$	≤ ± 0.023 % $C_n/5$ K
• Characteristic value $T_{KC}$	≤ ± 0.017 % $C_n/5$ K

#### Electrical characteristic values

Recommended reference voltage $U_{ref}$	5 ... 12 V DC
Input resistance $R_e$	700 Ω ± 7 Ω
Output resistance $R_a$	700 Ω ± 7 Ω
Insulation resistance $R_{is}$	5 000 MΩ at 50 V DC

#### Connection and ambient conditions

Sensor material (DIN)	Stainless steel
<b>Function</b>	<b>Color</b>
• EXC + (supply +)	Green
• EXC - (supply -)	Black
• SIG + (measured signal +)	White
• SIG - (measured signal -)	Red
• Sense + (sensor line +)	Yellow
• Sense - (sensor line -)	Blue
• Shield	Transparent
Rated temperature range $B_{tn}$	-10 ... +40 °C (14 ... 104 °F)
Operating temperature range $B_{tu}$	-35 ... +65 °C (-31 ... +149 °F)
Storage temperature range $B_{ts}$	-35 ... +65 °C (-31 ... +149 °F)
Degree of protection according to EN 60529; IEC 60529	IP68

#### Certificates and approvals

Accuracy class according to OIML R60	C3
--------------------------------------	----

#### Selection and Ordering data

Order No.

##### Load cell type WL270 CP-S SB

Legal-for-trade according to OIML R60 up to 3 000d, connecting cable 20 m (65.62 ft)

7MH5110-

■	■	D	0	■
---	---	---	---	---

##### Rated load

100 t (98.42 tn. L.)

6 A

##### Explosion protection

Without

0

Explosion protection for zones 0, 1, 2, 20, 21, 22

1

### Dimensional drawings

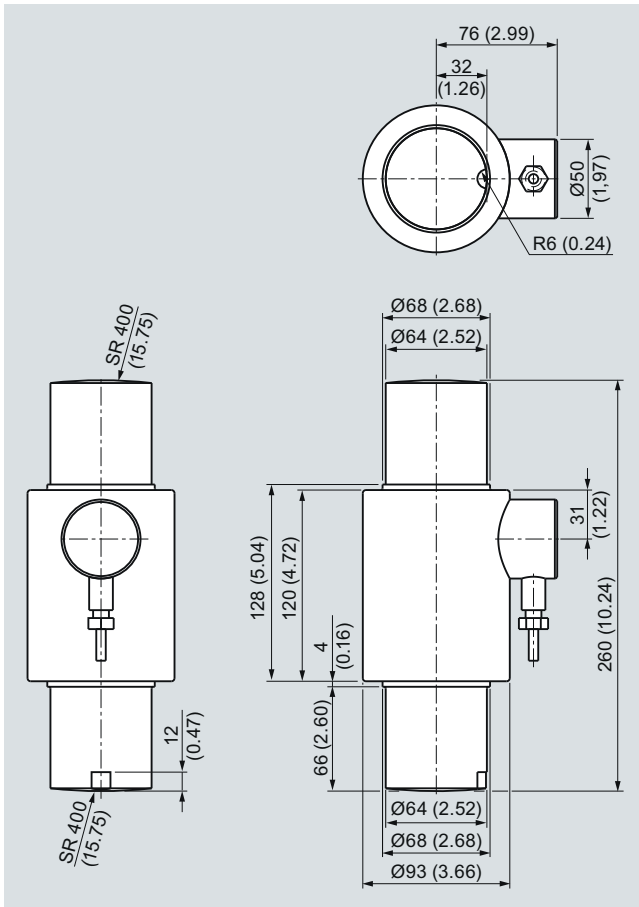

SIWAREX WL270 CP-S SB load cell, dimensions in mm (inch)

# Load cells

## SIWAREX WL200-SIWAREX WL270 CP-S SB

### Pressure piece set

#### Overview



In combination with a pressure piece set, the SIWAREX WL270 CP-S SA load cell produces a self-centering self-aligning bearing. This unit is particularly suitable for installation in container, hopper and vehicle scales.

#### Dimensional drawings

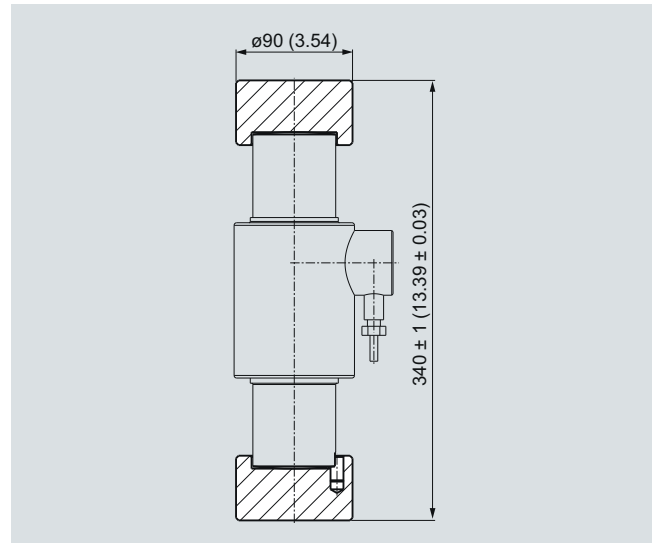

Pressure piece for SIWAREX WL270 CP-S SB load cells, dimensions in mm (inch)

#### Design

The pressure piece set consists of an upper and lower pressure piece. Together with the load cell the pressure piece set forms a self-centering unit with integrated torsion guard.

The self-centering, self-aligning bearing thus formed allows the load bearing implement to follow horizontal displacements (e. g. due to temperature fluctuations). In this case the construction of the self-aligning bearing creates a restoring force which is dependent on the size of the displacement and the applied load.

If the load support is laterally displaced by more than 8 mm (0.32 inch), the design of the load support must include measures for restricting sideways play (e.g. stops or guide elements). Lifting of the load support must be prevented by suitable measures provided in the construction of the load bearing implement.

The load cell must be ordered separately.

#### Selection and Ordering data

Order No.

##### Pressure piece set<sup>1)</sup>

For the individual installation of load cells from the SIWAREX WL270 CP-S SB series

Material: Stainless steel

For load cells with a rated load of<sup>2)3)</sup>

100 t (110.23 tn. L.)

**7MH5710-6AD00**

- 1) The principles of general mechanical engineering and safety must be observed.
- 2) It is highly recommendable to use a grounding cable (7MH3701-1AA1) in order to protect the load cell.
- 3) The load cell is not included in the scope of delivery.

# Load cells

## SIWAREX WL200-SIWAREX WL270 CP-S SB

### Compact mounting unit

#### Overview

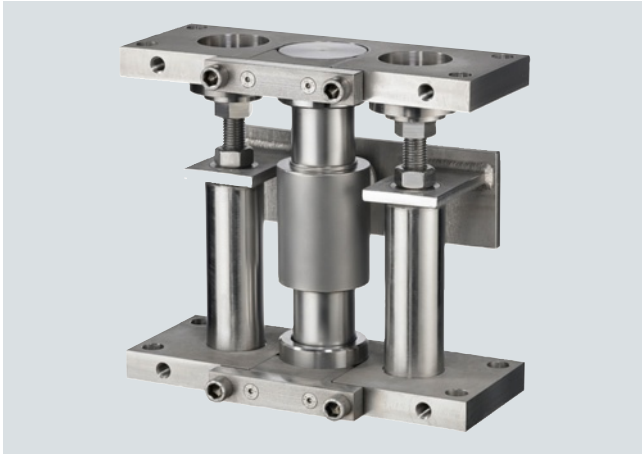

The self-centering compact mounting unit for SIWAREX WL270 CP-S SB load cells is particularly suitable for implementation in container scales.

#### Design

The compact mounting unit comprises a base plate and a top plate, two pressure pieces, two clamping pieces and two centering sleeves. There are threaded holes in the base plate and top plate for the subsequent flange-fitting of guide elements.

The top plate is aligned and fixed above the base plate with the two centering sleeves. This results in a stable unit. The height of the top plate is adjusted so that it is five millimeters above the installation height with load cell.

Two pressure pieces are used to mount the load cell. They are fastened flush with the head plate and base plate using the clamping pieces.

In this state the compact mounting unit serves as an installation aid and can be used as a dummy for light installation jobs.

Prior to installation, the load cell is inserted into the compact mounting unit. Then the complete unit is installed in the scales. As the result, the load bearing implement and the mounting units are aligned. The load cells are not yet loaded.

Finally the load bearing implement is lowered by undoing two hex nuts under the centering sleeves. The weight now rests on the load cells.

In this state the load cell and the pressure pieces together form a self-centering unit. The compact mounting unit permits sideways displacement of the top plate, and hence of the load bearing implement, by up to eight millimeters in all directions. Two countersunk screws prevent the load bearing implement from being lifted off or toppling off.

Using the compact mounting unit as an installation aid results in optimum alignment of the load cells. This is essential for the load cells to perform at their best in terms of accuracy.

For maintenance or troubleshooting purposes the load cell can be relieved again by screwing up the hex nuts. Replacement of the load cell is then easy after the clamping pieces are released.

#### Selection and Ordering data

Order No.

##### Compact mounting unit

For load cells of the SIWAREX WL270 CP-S SB series

Material: Stainless steel

For load cells with a rated load of<sup>1)2)</sup>:

100 t (98.42 tn. L.)

**7MH5710-6AA00**

<sup>1)</sup> The load cell is not included in the scope of delivery.

<sup>2)</sup> It is highly recommendable to use a grounding cable (7MH3701-1AA1) in order to protect the load cell.

#### Dimensional drawings

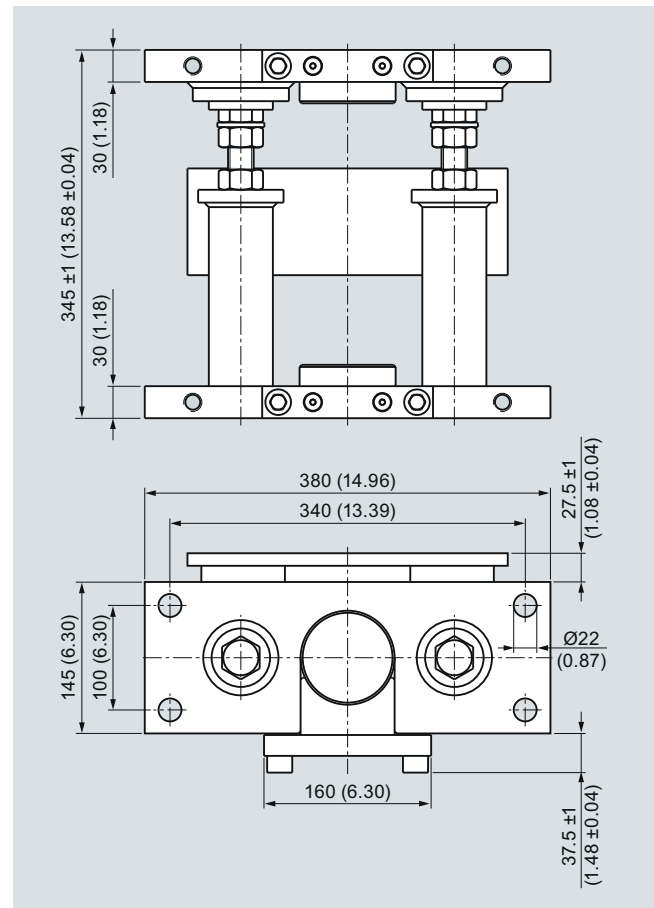

Compact mounting unit for SIWAREX WL270 CP-S SB load cell (mounting condition), dimensions in mm (inch)

# Load cells

## SIWAREX WL200-SIWAREX WL270 CP-S SC

### Load cell

#### Overview



The compression load cell is particularly suitable for implementation in container, hopper and vehicle scales.

#### Design

The measuring element is a solid cylinder made of stainless steel to which 4 strain gauges are applied.

The load which acts centrally in the measuring direction causes the spring bodies and therefore the friction-locked strain gauges to be elastically deformed. This generates a measuring signal voltage that is proportional to the load.

#### Technical specifications

##### SIWAREX WL270 CP-S SC

<b>Possible applications</b>	Container weighers
<b>Model</b>	Compression load cell
<b>Loads</b>	
Rated load $E_{max}$	200 t (196.84 tn. L.)
Minimum initial loading $E_{min}$	0 % $E_{max}$
Maximum working load $L_u$	150 % $E_{max}$
Ultimate load $L_d$	300 % $E_{max}$
Maximum lateral load $L_{lq}$	10 % $E_{max}$
<b>Measurement characteristic values</b>	
Rated measuring path $h_n$ at $E_{max}$	0.36 mm (0.01 inch)
Rated characteristic value $C_n$	$2.0 \pm 0.02$ % mV/V
Tolerance $D_0$ of zero signal	$\leq \pm 1.0$ % $C_n$
Repeatability $F_v$	$\pm 0.017$ % $C_n$
Creep error $F_{cr}$	
• 30 min	$\leq \pm 0.02$ % $C_n$
Temperature effect	
• Zero signal $T_{K0}$	$\leq \pm 0.017$ % $C_n/5$ K
• Characteristic value $T_{Kc}$	$\leq \pm 0.014$ % $C_n/5$ K
<b>Electrical characteristic values</b>	
Recommended reference voltage $U_{ref}$	5 ... 12 V DC
Input resistance $R_e$	$450 \Omega \pm 5 \Omega$
Output resistance $R_a$	$480 \Omega \pm 5 \Omega$
Insulation resistance $R_{is}$	5 000 M $\Omega$ at 50 V DC

#### Connection and ambient conditions

Sensor material (DIN)

Stainless steel

##### Function

- EXC + (supply +)
- EXC - (supply -)
- SIG + (measured signal +)
- SIG - (measured signal -)
- Shield

##### Color

Green  
Black  
White  
Red  
Transparent

Rated temperature range  $B_{Tn}$

-10 ... +40 °C (14 ... 104 °F)

Operating temperature range  $B_{Tu}$

-35 ... +65 °C (-31 ... +149 °F)

Storage temperature range  $B_{Ts}$

-35 ... +65 °C (-31 ... +149 °F)

Degree of protection according to EN 60529; IEC 60529

IP68

#### Certificates and approvals

Accuracy class

0.1 %

#### Selection and Ordering data

Order No.

##### Load cell type WL270 CP-C SC

Error of measurement 0.1 %, connection cable 20 m (65.62 ft)

##### Rated load

200 t (196.84 tn. L.)

**7MH5111-6GA00**

#### Dimensional drawings

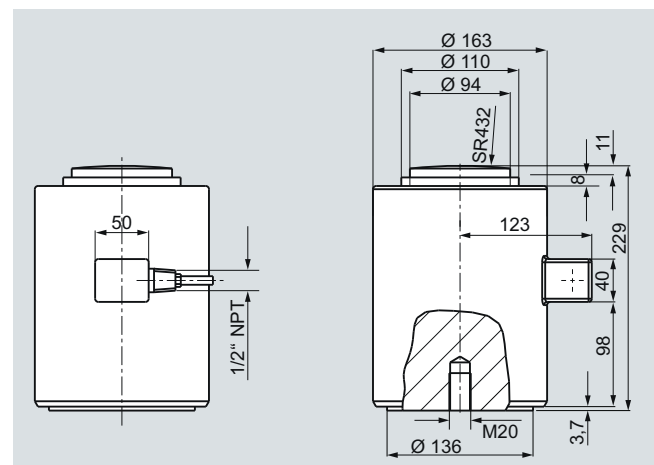

SIWAREX WL270 CP-S SC load cell, dimensions in mm (inch)

# Load cells

## SIWAREX WL200-SIWAREX WL270 K-S CA

Load cell

### Overview



The compression force load cell is particularly suitable for use in container and hopper scales.

### Design

The measuring element is a cylinder made of stainless steel to which 4 strain gauges are applied.

The load which acts centrally in the measuring direction elastically deforms the spring body and thus the force-fitted strain gauges. This generates a measuring signal voltage that is proportional to the load. The load cell's rated measuring path depends on the rated load and is between 0.23 and 2.67 mm (0.01 and 0.11 inch).

An enclosure made from painted steel protects the strain gauge from environmental influences.

### Technical specifications

#### SIWAREX WL270 K-S CA

<b>Possible applications</b>	<ul style="list-style-type: none"> <li>• Container weighers</li> <li>• Hopper scales</li> </ul>
<b>Model</b>	Compression load cell
<b>Loads</b>	
Rated load $E_{max}$	<ul style="list-style-type: none"> <li>• 2.8 t (2.76 tn. L.)</li> <li>• 6 t (5.91 tn. L.)</li> <li>• 13 t (12.79 tn. L.)</li> <li>• 28 t (27.56 tn. L.)</li> <li>• 60 t (59.05 tn. L.)</li> <li>• 130 t (127.95 tn. L.)</li> <li>• 280 t (275.58 tn. L.)</li> </ul>
Minimum initial loading $E_{min}$	0 % $E_{max}$
Maximum working load $L_U$	120 % $E_{max}$
Ultimate load $L_d$	300 % $E_{max}$
Maximum lateral load $L_{lq}$	10 % $E_{max}$

#### Measurement characteristic values

Rated measuring path $h_n$ at $E_{max}$	0.23 ... 2.67 mm (0.01 ... 0.11 inch)
Rated characteristic value $C_n$	1.5 mV/V
Tolerance $D_o$ of zero signal	$\leq \pm 1.5 \% C_n$
Tolerance $D_c$ of characteristic value	$\pm 0.5 \%$
Temperature effect	
• Zero signal $T_{K0}$	$\leq \pm 0.25 \% C_n/5 K$
• Characteristic value $T_{KC}$	$\leq \pm 0.25 \% C_n/5 K$

#### Electrical characteristic values

Recommended reference voltage $U_{ref}$	6 ... 12 V DC
Supply voltage $U_{sr}$ (reference value)	6 V
Input resistance $R_e$	$275 \Omega \pm 50 \Omega$
Output resistance $R_a$	$245 \Omega \pm 0,2 \Omega$
Insulation resistance $R_{is}$	$\geq 20 M\Omega$

#### Connection and ambient conditions

Sensor material (DIN)	Steel, painted
<u>Function</u>	<u>Color</u>
• EXC + (supply +)	Red
• EXC - (supply -)	White
• SIG + (measured signal +)	Black
• SIG - (measured signal -)	Blue
• Shield	Transparent
Rated temperature range $B_{Tn}$	-10 to 60 °C (14 to 140 °F)
Operating temperature range $B_{Tu}$	-20 to 70 °C (-4 to +158 °F)
Storage temperature range $B_{Ts}$	-30 to 80 °C (-22 to +176 °F)
Degree of protection according to EN 60529; IEC 60529	IP66

#### Certificates and approvals

Accuracy class	0.1 %
----------------	-------

### Selection and Ordering data

SIWAREX WL270 K-S CA load cell		Order No.
Accuracy class 0.1 % without explosion protection heat resistant connecting cable <sup>1)</sup>		<b>7MH5114-</b>
		<b>L 0 0</b>
<b>Rated load</b>	<b>Cable length</b>	
• 2.8 t (2.76 tn. L.)	6 m (19.68 ft)	<b>4 J</b>
• 6 t (5.91 tn. L.)	6 m (19.68 ft)	<b>4 Q</b>
• 13 t (12.79 tn. L.)	15 m (49.21 ft)	<b>5 D</b>
• 28 t (27.56 tn. L.)	15 m (49.21 ft)	<b>5 J</b>
• 60 t (59.05 tn. L.)	15 m (49.21 ft)	<b>5 Q</b>
• 130 t (127.95 tn. L.)	20 m (65.62 ft)	<b>6 D</b>
• 280 t (275.58 tn. L.)	20 m (65.62 ft)	<b>6 J</b>

<sup>1)</sup> Heat-resistant cable: -60 ... +180 °C (-76 ... +356 °F)

# Load cells

## SIWAREX WL200-SIWAREX WL270 K-S CA

### Load cell

### Dimensional drawings

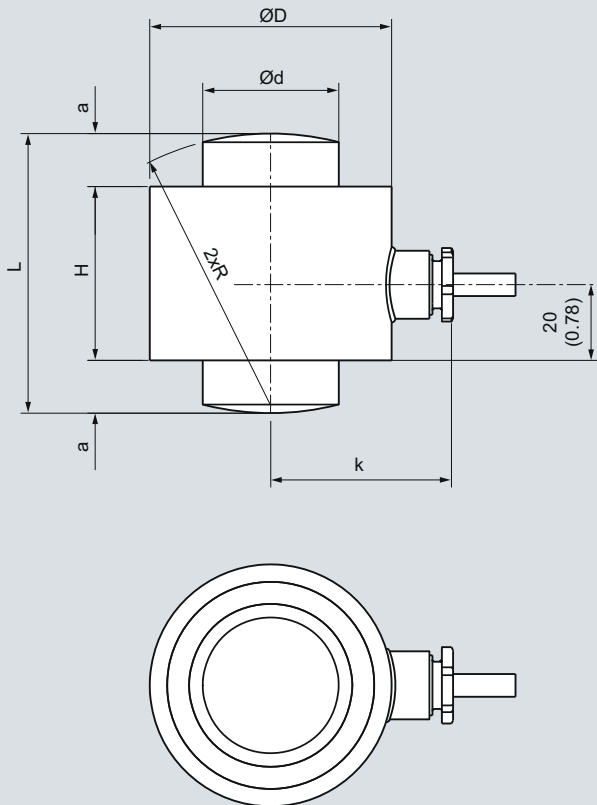

Rated load [t]	a	ød	øD	H	k	L	R
2, 8, 6	8 (0.31)	16.7 (0.65)	45 (1.77)	40 (1.57)	40 (1.57)	56 (2.2)	50 (1.96)
13	12 (0.47)	24.5 (0.96)	55 (2.16)	44 (1.73)	45 (1.77)	68 (2.67)	66 (2.6)
28	14 (0.55)	36 (1.41)	64 (2.51)	46 (1.81)	48 (1.88)	74 (2.91)	72 (2.83)
60	20 (0.78)	52.7 (2.07)	90 (3.54)	50 (1.96)	63 (2.48)	90 (3.54)	100 (3.93)
130	26 (1.02)	77.5 (3.05)	121 (4.76)	64 (2.51)	78 (3.07)	116 (4.56)	125 (4.92)
280	45 (1.77)	114 (4.48)	165 (6.5)	80 (3.14)	100 (3.93)	170 (6.7)	183 (7.2)

SIWAREX WL270 K-S CA load cell, dimensions in mm (inch)



# Load cells

## SIWAREX WL200-SIWAREX WL270 K-S CA

### Self-aligning bearing

#### Overview



The self-aligning bearing for SIWAREX WL270 K-S CA load cells is particularly suitable for installation in container and hopper scales.

#### Design

The self-aligning bearing consists of two pressure plates.

In combination with the load cell, the pressure plates form a self-centering unit. This allows the top plate and thus the load carrier to follow horizontal displacements (e. g. due to temperature fluctuations). The construction of the self-aligning bearing creates a restoring force which is dependent on the size of the displacement and the applied load.

If the load carrier is displaced by more than the value  $s$  (see table in dimensional drawing) in the horizontal direction, measures for restricting sideways play (e. g. stops) must be implemented in the construction of the load carrier. Suitable measures must be provided on the construction of the load carrier to prevent it from raising up.

The load cell is not included in the scope of delivery of the self-aligning bearing.

#### Selection and Ordering data

Order No.

##### Pressure plate<sup>1)2)</sup>

For SIWAREX WL270 K-S CA load cells  
2 pressure plates are required to set up a self-aligning bearing, one each at the top and bottom respectively.

Material: Steel, painted

For load cells with a rated load of

- 2.8, 6 t (2.76, 5.91 tn. L.) **7MH3115-3AA1**
- 13 t (12.79 tn. L.) D) **7MH3115-1BA1**
- 28 t (27.56 tn. L.) D) **7MH3115-2BA1**
- 60 t (59.05 tn. L.) D) **7MH3115-3BA1**
- 130 t (127.95 tn. L.) D) **7MH3115-1CA1**
- 280 t (275.58 tn. L.) D) **7MH3115-2CA1**

<sup>1)</sup> The load cell is not included in the scope of delivery.

<sup>2)</sup> It is highly recommendable to use a grounding cable (7MH3701-1AA1) in order to protect the load cell.

D) Subject to export regulations AL: N, ECCN: EAR99H.

#### Dimensional drawings

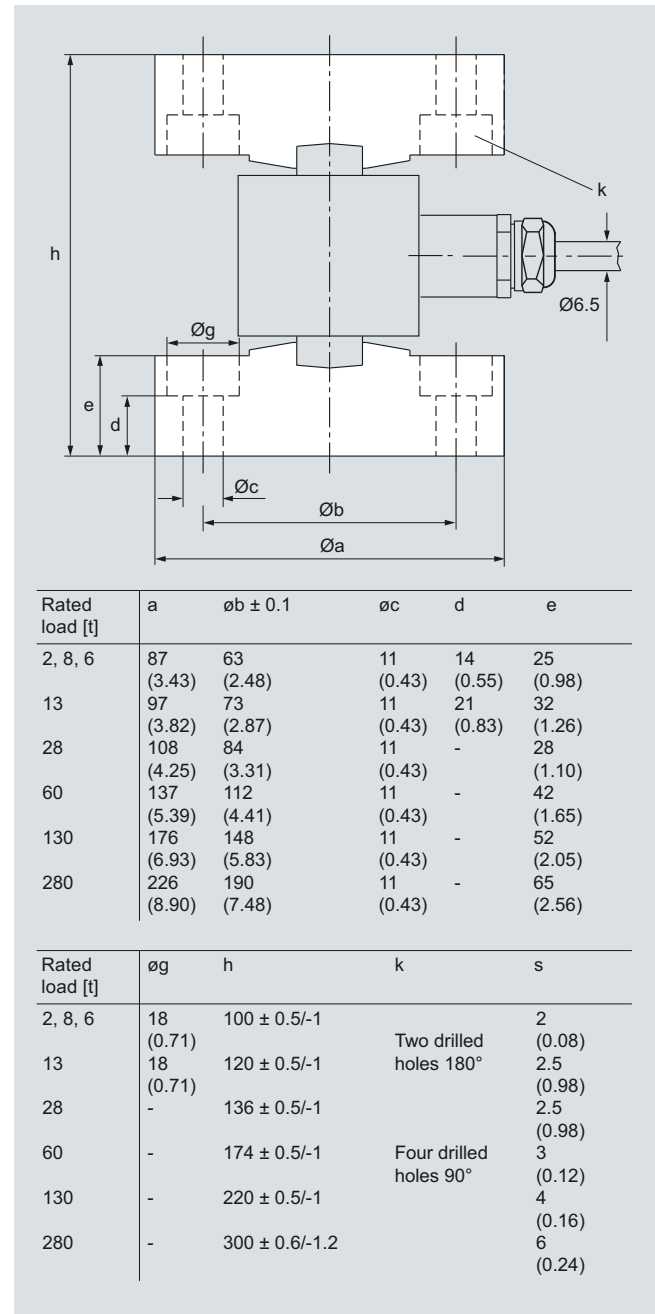

Self-aligning bearing for SIWAREX WL270 K-S CA load cell, dimensions in mm (inch)

# Load cells

## SIWAREX WL200-SIWAREX WL280 RN-S SA

### Load cell

#### Overview



The ring-torsion load cell is particularly suitable for use in container, belt, platform and roller table scales.

#### Design

The measuring element is a stainless steel ring-torsion spring body. Two expansion measuring spirals each are applied to the upper and lower faces of the ring. The spring body is deformed by the load, impacting centrally in the direction of measurement. As a result, the diameter of the upper ring end face decreases and the diameter of the lower ring end face increases. This results in a change in the electrical resistance of the force-fitted strain gauges, which is evaluated using a bridge circuit.

All load cells with a rated load of up to 13 t (12.79 tn. L.) are fitted with an integrated overload protection.

#### Technical specifications

##### SIWAREX WL280 RN-S SA load cell

##### Possible applications

- Container weighers
- Conveyor scales
- Platform scales
- Roller table scales

##### Model

Ring-torsion load cell

##### Loads

Rated load $E_{max}$	<ul style="list-style-type: none"> <li>• 60 kg (132.28 lb)</li> <li>• 130 kg (286.60 lb)</li> <li>• 280 kg (617.29 lb)</li> </ul>	<ul style="list-style-type: none"> <li>• 0.5 t (0.49 tn. L.)</li> <li>• 1 t (0.98 tn. L.)</li> <li>• 2 t (1.97 tn. L.)</li> <li>• 3.5 t (3.45 tn. L.)</li> <li>• 5 t (4.92 tn. L.)</li> <li>• 10 t (9.84 tn. L.)</li> </ul>	<ul style="list-style-type: none"> <li>• 13 t (12.80 tn. L.)</li> <li>• 28 t (27.56 tn. L.)</li> <li>• 60 t (59.05 tn. L.)</li> </ul>
Minimum initial loading $E_{min}$	$\geq 0 \% E_{max}$	$\geq 0 \% E_{max}$	$\geq 0 \% E_{max}$
Maximum working load $L_U$	200 % $E_{max}$	150 % $E_{max}$	150 % $E_{max}$
Ultimate load $L_d$	500 % $E_{max}$	300 % $E_{max}$	300 % $E_{max}$
Maximum lateral load $L_{lq}$	75 % $E_{max}$	100 % $E_{max}$	75 % $E_{max}$

##### Measurement characteristic values

Rated measuring path $h_n$ at $E_{max}$	0.07 mm (0.003 inch)	0.1 ± 0.02 mm (0.04 ± 0.0008 inch)	0.11 ... 0.2 mm (0.004 ... 0.008 inch)
Rated characteristic value $C_n$	1 mV/V	2 mV/V	2 mV/V
Tolerance $D_o$ of zero signal	$\leq \pm 1,0 \% C_n$	$\leq \pm 1,0 \% C_n$	$\leq \pm 1,0 \% C_n$
Maximum load cell verification interval $n_{LC}$	3 000	3 000	3 000
Minimum load cell verification interval $V_{min}$	$E_{max}/16\ 000$	$E_{max}/17\ 500$	$E_{max}/17\ 500$
Minimum application range $R_{min(LC)}$	19 %	17 %	17 %
Combined error $F_{comb}$	$\leq \pm 0,02 \% C_n$	$\leq \pm 0,02 \% C_n$	$\leq \pm 0,02 \% C_n$
Repeatability $F_V$	$\leq \pm 0,01 \% C_n$	$\leq \pm 0,01 \% C_n$	$\leq \pm 0,01 \% C_n$
Return of zero signal	$\leq \pm 0,0167 \% C_n^{(1)}$	$\leq \pm 0,0167 \% C_n^{(1)}$	$\leq \pm 0,0167 \% C_n^{(1)}$
Creep error $F_{cr}$			
• 30 min	$\leq \pm 0,0245 \% C_n^{(1)}$	$\leq \pm 0,0245 \% C_n^{(1)}$	$\leq \pm 0,0245 \% C_n^{(1)}$
• 20 ... 30 min	$\leq \pm 0,0053 \% C_n^{(1)}$	$\leq \pm 0,0053 \% C_n^{(1)}$	$\leq \pm 0,0053 \% C_n^{(1)}$
Temperature effect			
• Zero signal $T_{K0}$	$\leq \pm 0,004 \% C_n/5K$	$\leq \pm 0,004 \% C_n/5K$	$\leq \pm 0,004 \% C_n/5K$
• Characteristic value $T_{Kc}$	$\leq \pm 0,004 \% C_n/5K$	$\leq \pm 0,004 \% C_n/5K$	$\leq \pm 0,004 \% C_n/5K$

### Technical specifications (continued)

#### SIWAREX WL280 RN-S SA load cell

##### Electrical characteristic values

Overload protection	Integrated	Integrated	Integrated at 13 t (12.80 tn. L.)
Recommended reference voltage $U_{ref}$	5 ... 30 V	5 ... 30 V	5 ... 30 V
Supply voltage $U_{sr}$ (reference value)	15 V	10 V	15 V
Tolerance $D_c$ of characteristic value	0.01 mV/V	0.1 mV/V	0.1 mV/V
Input resistance $R_e$	60 kg (132.28 lb), 130 kg (286.60 lb): 1260 $\Omega \pm 100 \Omega$	1100 $\Omega \pm 100 \Omega$	13 t (11.61 tn. L.): 1200 $\Omega \pm 100 \Omega$
	280 kg (617.29 lb): 1260 $\Omega \pm 250 \Omega$		28 t (25.00 tn. L.): 1075 $\Omega \pm 100 \Omega$
Output resistance $R_a$	1020 $\Omega \pm 0.5 \Omega$	1025 $\Omega \pm 25 \Omega$	60 t (53.57 tn. L.): 1350 $\Omega \pm 200 \Omega$
			13 t (11.61 tn. L.): 1000 $\Omega \pm 0.5 \Omega$
			28 t (25.00 tn. L.): 930 $\Omega \pm 0.5 \Omega$
			60 t (53.57 tn. L.): 1175 $\Omega \pm 0.5 \Omega$
Insulation resistance $R_{is}$	$\geq 20 \text{ M}\Omega$	$\geq 5\,000 \text{ M}\Omega$	$\geq 20 \text{ M}\Omega$
Current calibration <sup>2)</sup>	Standard	Standard	Standard

##### Connection and ambient conditions

Sensor material (DIN)	Stainless steel, mat. no. 14542	Stainless steel, mat. no. 14542	Stainless steel, mat. no. 14542
Recommended tightening torque of the fixing screws	8 Nm	10 Nm	-
<u>Function</u>	<u>Color</u>	<u>Color</u>	<u>Color</u>
• EXC + (supply +)	Pink	Pink	Pink
• EXC - (supply -)	Gray	Gray	Gray
• SIG + (measured signal +)	Brown	Brown	Brown
• SIG - (measured signal -)	White	White	White
• Shield	Transparent	Transparent	Transparent
Rated temperature range $B_{rn}$	-10 ... +40 °C (14 ... 158 °F)	-10 ... +40 °C (14 ... 158 °F)	-10 ... +40 °C (14 ... 158 °F)
Operating temperature range $B_{tu}$	-35 ... +70 °C (95 ... 104 °F)	-35 ... +70 °C (95 ... 104 °F)	-35 ... +70 °C (95 ... 104 °F)
Storage temperature range $B_{is}$	-50 ... +90 °C (122 ... 194 °F)	-50 ... +90 °C (122 ... 194 °F)	-50 ... +90 °C (122 ... 194 °F)
Degree of protection according to EN 60529; IEC 60529	IP66/68	IP66/68	IP66/68

##### Certificates and approvals

Accuracy class according to OIML R60	C3	C3	C3
Ex protection to ATEX (optional)	Available soon	Available soon	Available soon

<sup>1)</sup> For rated temperature -10 ... +40 °C (14 ... 104 °F)

<sup>2)</sup> Current calibration: rated characteristic value and output resistance are adjusted so that the output current is calibrated within 0.05 % of a reference value. This makes it easier to connect several load cells in parallel.

# Load cells

## SIWAREX WL200-SIWAREX WL280 RN-S SA

### Load cell

#### Selection and Ordering data

Order No.

#### SIWAREX WL280 RN-S SA load cell

7MH5113-

Stainless steel, low mounting height, IP66/68  
accuracy class C3 acc. to OIML R60<sup>1)</sup>

D 0

#### Rated load

#### Cable length

• 60 kg (132.28 lb)	3 m (9.84 ft)	<b>2 Q</b>
• 130 kg (286.60 lb)	3 m (9.84 ft)	<b>3 D</b>
• 280 kg (617.29 lb)	3 m (9.84 ft)	<b>3 J</b>
• 500 kg (1102.31 lb)	3 m (9.84 ft)	<b>3 P</b>
• 1 t (0.98 tn. L.)	3 m (9.84 ft)	<b>4 A</b>
• 2 t (1.97 tn. L.)	6 m (19.68 ft)	<b>4 G</b>
• 3.5 t (3.44 tn. L.)	6 m (19.68 ft)	<b>4 L</b>
• 5 t (4.92 tn. L.)	6 m (19.68 ft)	<b>4 P</b>
• 10 t (9.84 tn. L.)	15 m (49.21 ft)	<b>5 A</b>
• 13 t (12.79 tn. L.)	15 m (49.21 ft)	<b>5 D</b>
• 28 t (27.56 tn. L.)	15 m (49.21 ft)	<b>5 J</b>
• 60 t (59.05 tn. L.)	15 m (49.21 ft)	<b>5 Q</b>

#### Explosion protection<sup>2)</sup>

Without

0

Explosion protection for  
zones 1, 2, 20, 21, 22

1

<sup>1)</sup> OIML R60 test certificate available soon

<sup>2)</sup> ATEX certification available soon

## Dimensional drawings

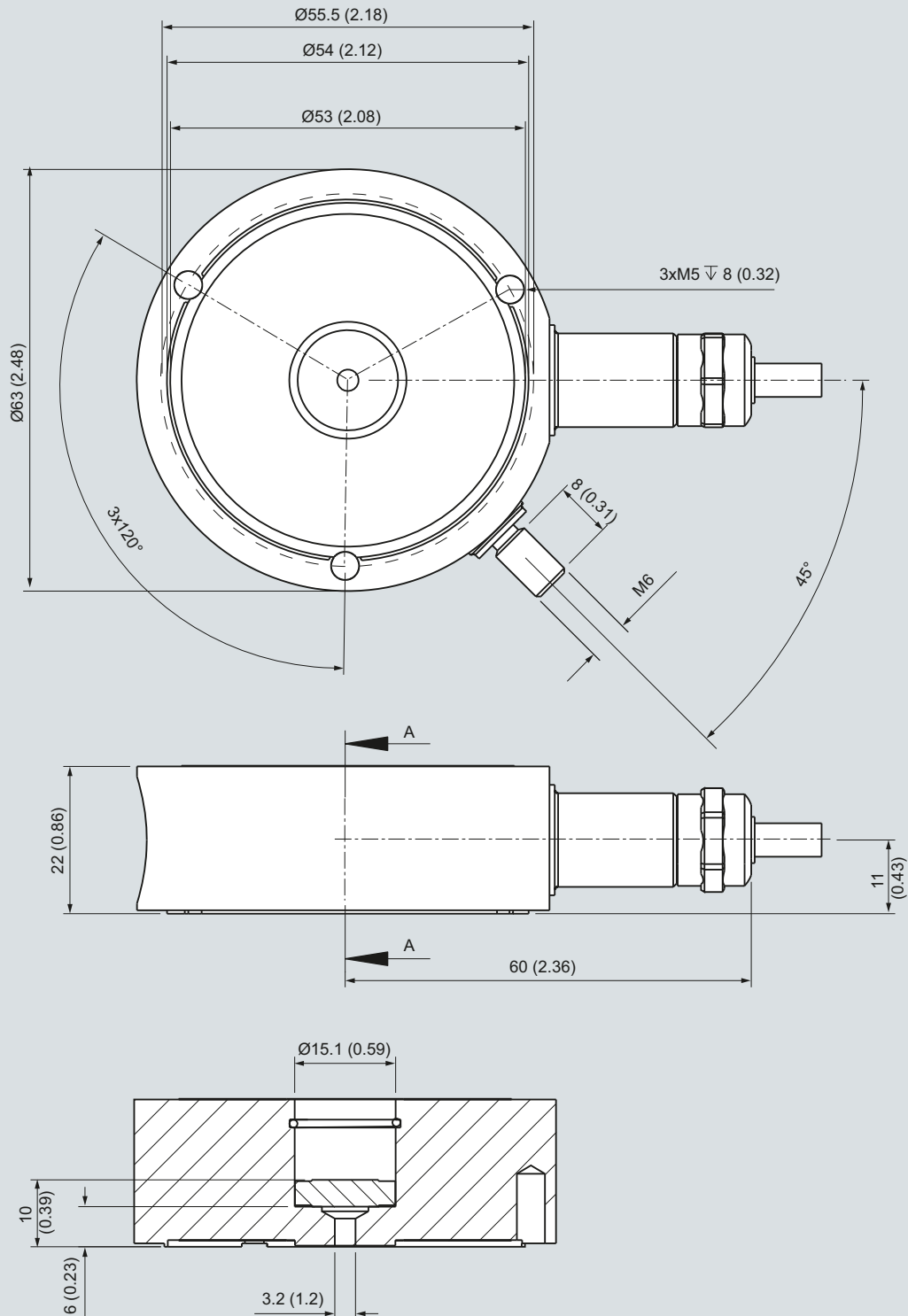

SIWAREX WL280 RN-S SA load cell (60 kg, 130 kg, 280 kg (132.28 lb, 286.60 lb, 617.29 lb)), dimensions in mm (inch)

# Load cells

## SIWAREX WL200-SIWAREX WL280 RN-S SA

### Load cell

#### Dimensional drawings (continued)

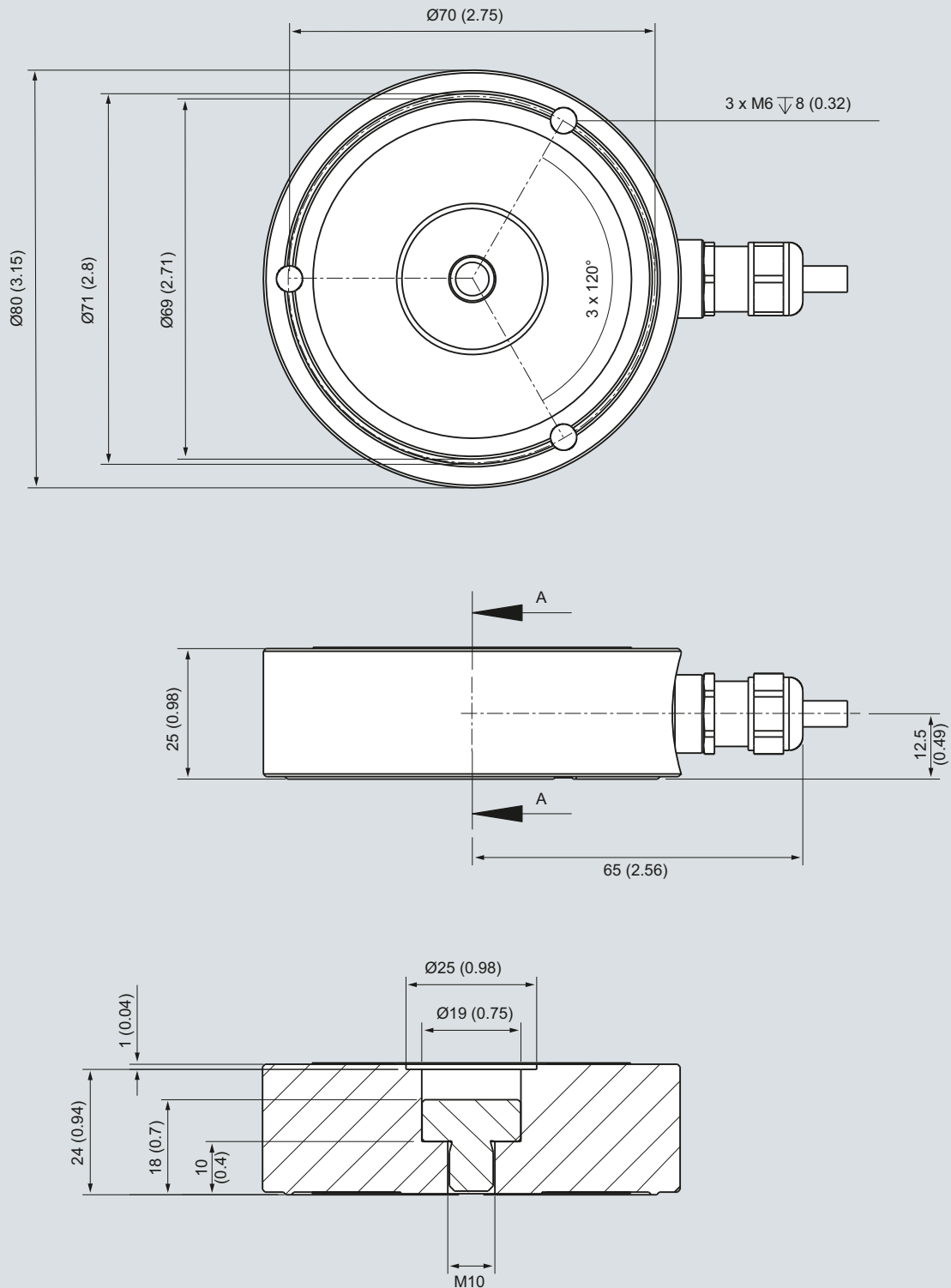

SIWAREX WL280 RN-S SA load cell (0.5, 1 t (0.49., 0.98 tn. L.)), dimensions in mm (inch)

## Dimensional drawings (continued)

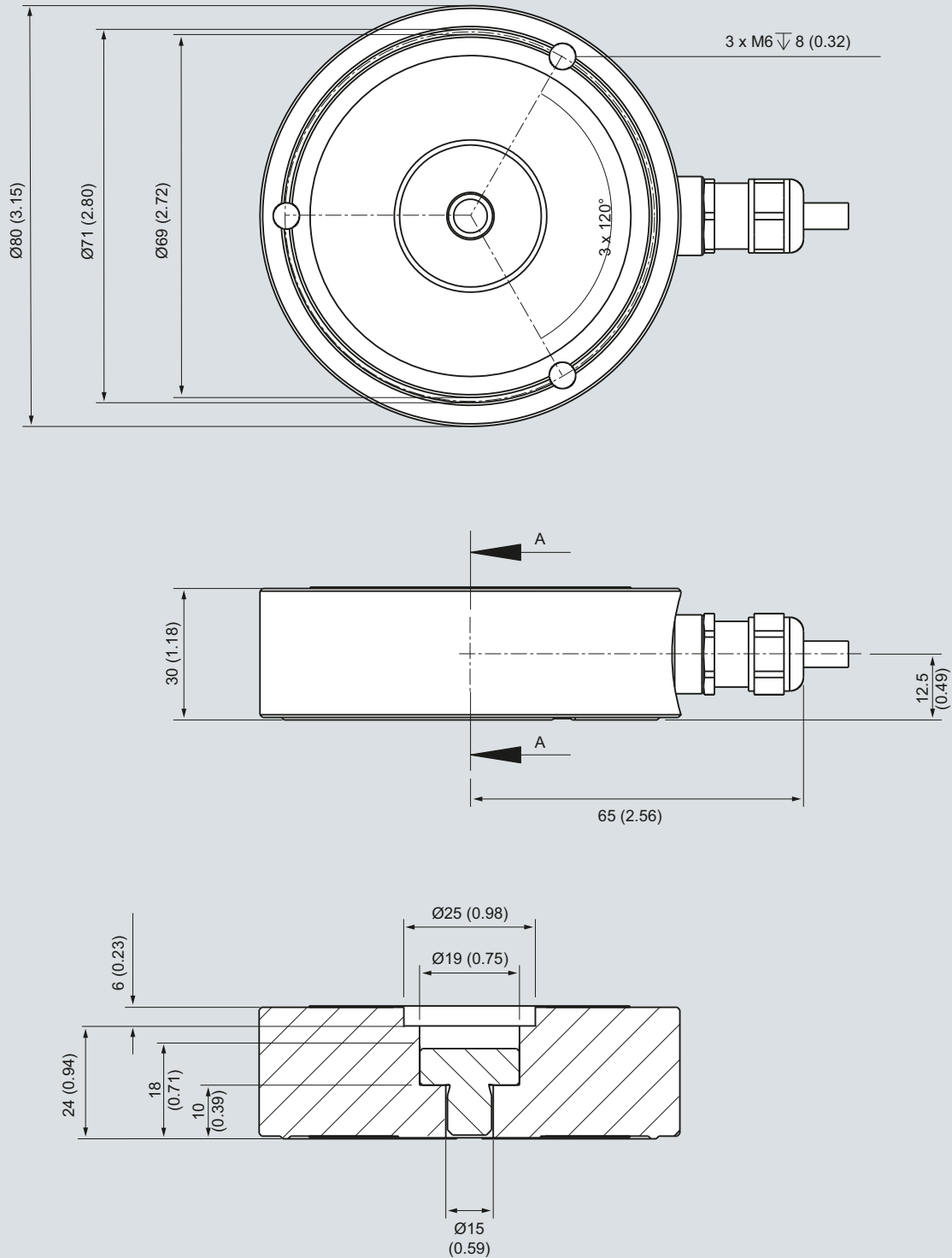

SIWAREX WL280 RN-S SA load cell (2, 3, 5 (1.97, 2.95, 4.92 tn. L.)), dimensions in mm (inch)

# Load cells

## SIWAREX WL200-SIWAREX WL280 RN-S SA

### Load cell

#### Dimensional drawings (continued)

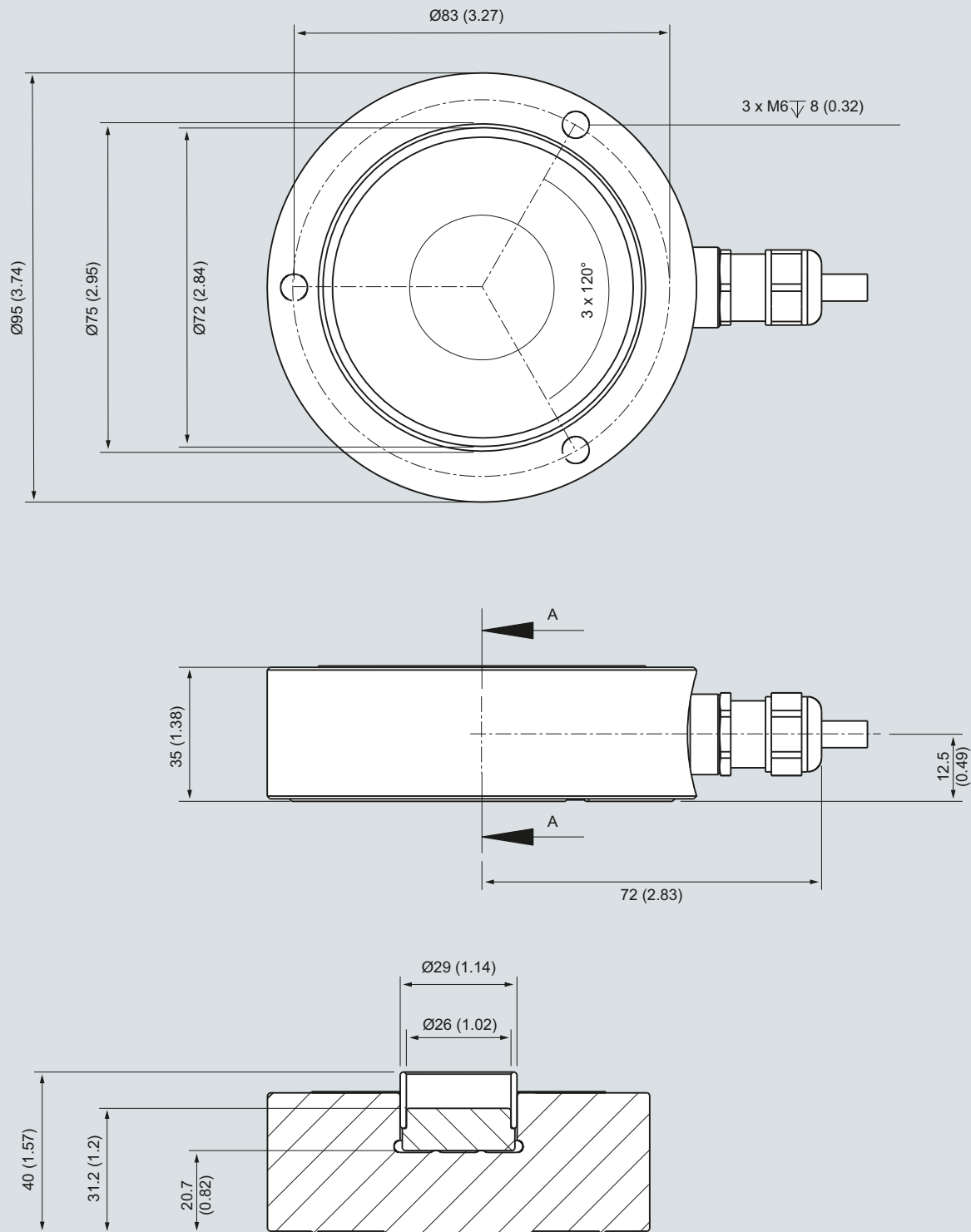

SIWAREX WL280 RN-S SA load cell (10 t (9.84 tn. L.)), dimensions in mm (inch)



## Dimensional drawings (continued)

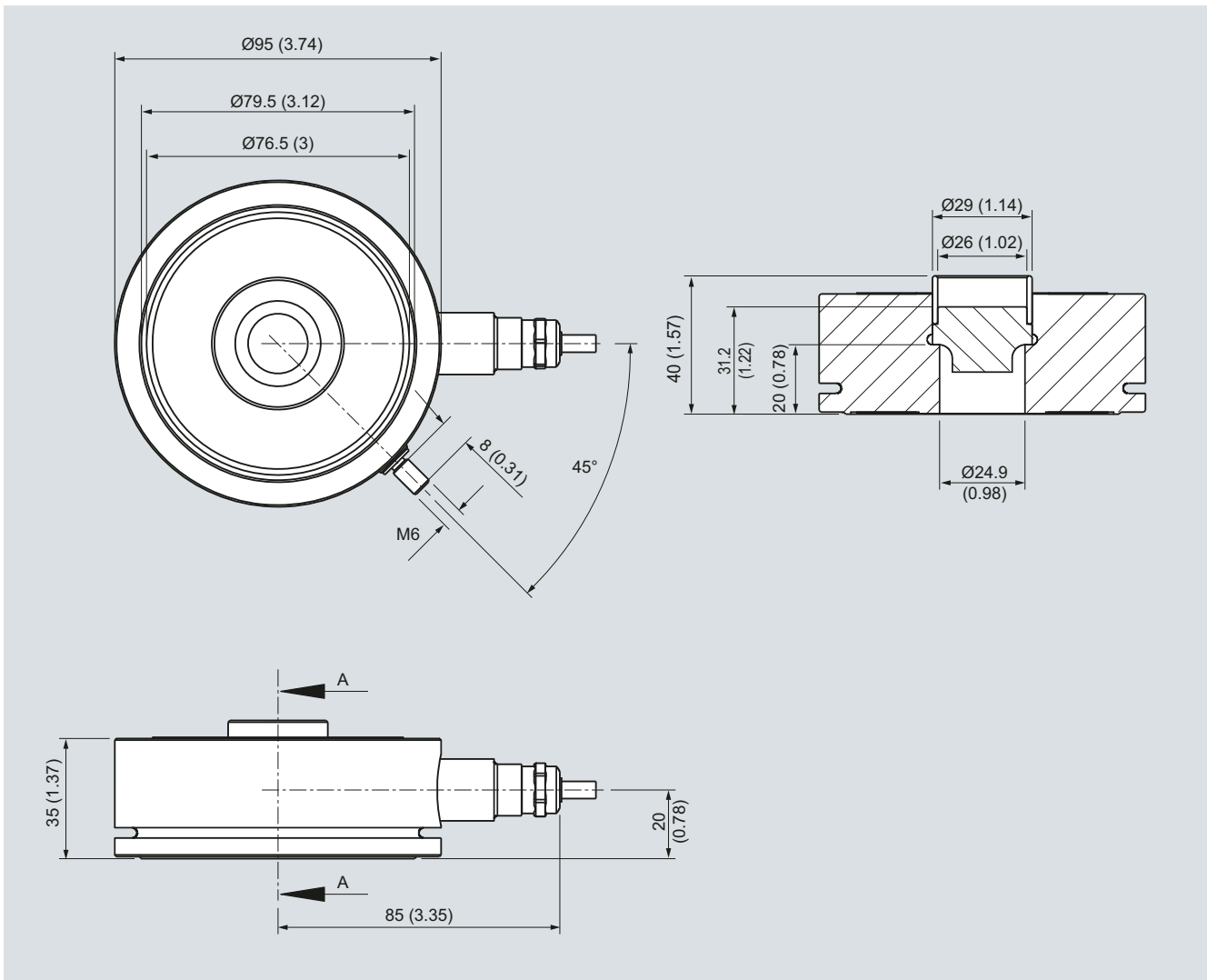

SIWAREX WL280 RN-S SA load cell (13 t (12.79 tn. L.)), dimensions in mm (inch)

# Load cells

## SIWAREX WL200-SIWAREX WL280 RN-S SA

### Load cell

#### Dimensional drawings (continued)

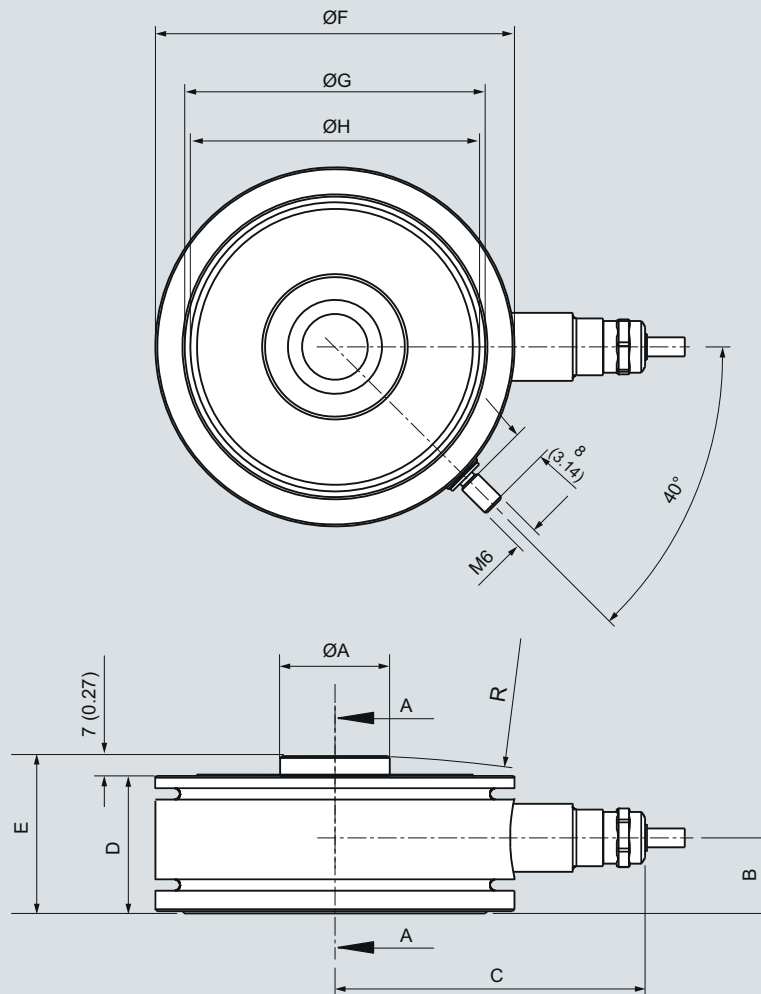

Rated load [t]	$\varnothing A$	B	C	D	E	$\varnothing F$	$\varnothing G$	$\varnothing H$	R
28 t	35.9 (1.41)	25 (0.98)	94 (3.7)	46 (1.8)	53 (2.08)	120 (4.72)	102 (4)	98 (3.85)	R400
60 t	47.9 (1.88)	34 (1.33)	105 (4.13)	62 (2.44)	69 (2.71)	140 (5.5)	124 (4.88)	120 (4.72)	R600

SIWAREX WL280 RN-S SA load cell (28, 60 t (27.56, 59.05 tn. L.)), dimensions in mm (inch)

## Overview

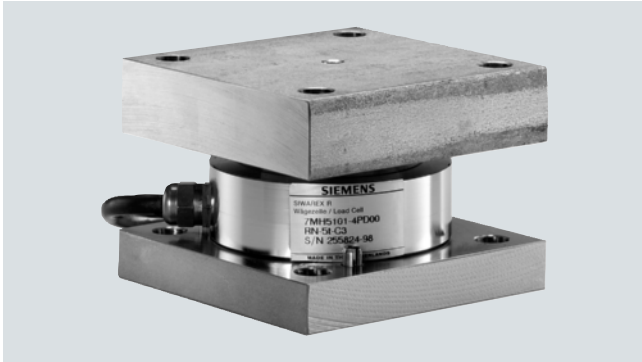

The self-aligning bearing for SIWAREX WL280 RN-S SA load cells is particularly suitable for container and platform scales due to its low mounting height.

## Design

The self-aligning bearing comprises a self-aligning bolt, a top plate (self-aligning bearing, top part) and a base plate (self-aligning bearing, base part).

The self-aligning bolt allows the top plate, and thus the load support, to accommodate horizontal displacements (e.g. due to temperature fluctuations). The design of the self-aligning bolt creates a restoring force, which is dependent on the size of the displacement and the applied load.

The design of the load support must be such as to limit the lateral play (e.g. with limit stops), if the load support is displaced horizontally by the following values:

- > 4 mm (0.16 inch) (up to 5 t (4.92 tn. L.) rated load)
- > 7 mm (0.28 inch) (up to 13 t (12.80 tn. L.) rated load)
- > 10 mm (0.39 inch) (up to 60 t (59.05 tn. L.) rated load)

Lifting of the load support must be prevented by suitable measures provided in the construction of the load bearing implement.

The load cell is not included in the scope of delivery of the self-aligning bearing.

## Selection and Ordering data

Order No.

Self-aligning bearing top part<sup>1)2)</sup>

For SIWAREX WL280 RN-S SA load cells comprising: Top plate with seal holder and sealing ring, top plate pressure piece, self-aligning bolt, cell pressure piece (not for 28 t (27.56 tn. L.) and 60 t (59.05 tn. L.))

Material: Stainless steel

For load cells with a rated load of:

- |  |    |                      |
|--|----|----------------------|
| • 60, 130, 280 kg<br>(132.28, 286.60, 617.29 lb) |    | <b>7MH4115-3DB11</b> |
| • 0.5, 1 t (0.49, 0.98 tn. L.)                   |    | <b>7MH4132-4AK11</b> |
| • 2, 3.5, 5 t (1.97, 3.45, 4.92 tn. L.)          |    | <b>7MH4132-4KK11</b> |
| • 10, 13 t (9.84, 12.80 tn. L.)                  | D) | <b>7MH4115-5BB11</b> |
| • 28 t (27.56 tn. L.)                            | D) | <b>7MH4115-5DB11</b> |
| • 60 t (59.05 tn. L.)                            | D) | <b>7MH4115-5GB11</b> |

Self-aligning bearing base part<sup>1)</sup>

For SIWAREX WL280 RN-S SA load cells comprising: Base plate, 3 tension pins

Material: Stainless steel

For load cells with a rated load of:

- |  |    |                      |
|--|----|----------------------|
| • 60, 130, 280 kg<br>(132.28, 286.60, 617.29 lb) |    | <b>7MH4115-3DC11</b> |
| • 0.5, 1 t (0.49, 0.98 tn. L.)                   |    | <b>7MH4132-4AG11</b> |
| • 10, 13 t (9.84, 12.80 tn. L.)                  | D) | <b>7MH4115-5BC11</b> |
| • 28 t (27.56 tn. L.)                            | D) | <b>7MH4115-5DC11</b> |
| • 60 t (59.05 tn. L.)                            | D) | <b>7MH4115-5GC11</b> |

<sup>1)</sup> The load cell is not included in the scope of delivery.

<sup>2)</sup> The self-aligning bearing base part is not included in delivery.

D) Subject to export regulations AL: N, ECCN: EAR99H.

# Load cells

## SIWAREX WL200-SIWAREX WL280 RN-S SA

### Self-aligning bearing

#### Dimensional drawings

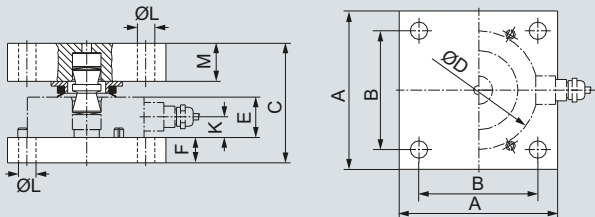

Rated load	A	B	C	ØD	E
60 ... 280 kg	80 (3.15)	60 (2.36)	52 (2.05)	63 (2.48)	22 (0.87)
0.5 t, 1 t	100 (3.94)	75 (2.95)	79 (3.11)	80 (3.15)	25 (0.98)
2 t, 3.5 t, 5 t	100 (3.94)	75 (2.95)	79 (3.11)	80 (3.15)	30 (1.18)
10 t, 13 t	120 (4.72)	90 (3.54)	121.2 (4.77)	95 (3.74)	35 (1.97)

Rated load	F	K	ØL	M
60 ... 280 kg	8 (0.31)	11 (0.43)	9 (0.35)	12 (0.47)
0.5 t, 1 t	15 (0.59)	10 (0.39)	11 (0.43)	25 (0.98)
2 t, 3.5 t, 5 t	15 (0.59)	8.5 (0.33)	11 (0.43)	25 (0.98)
10 t, 13 t	20 (0.79)	20 (0.79)	14 (0.55)	40 (1.57)

Self-aligning bearing for SIWAREX WL280 RN-S SA load cell, 0.06 ... 13 t (0.07 ... 14.33 tn. L.), dimensions in mm (inch)

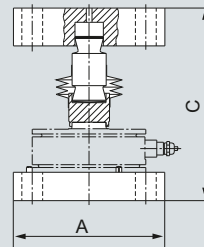

Rated load [t]	A	C
28	160 (6.30)	203 (7.99)
60	200 (7.87)	254 (10.00)

Self-aligning bearing for SIWAREX WL280 RN-S SA load cell, 28 ... 60 t (27.56 ... 59.05 tn. L.), dimensions in mm (inch)

## SIWAREX WL200-SIWAREX WL280 RN-S SA

Elastomer bearing

## Overview

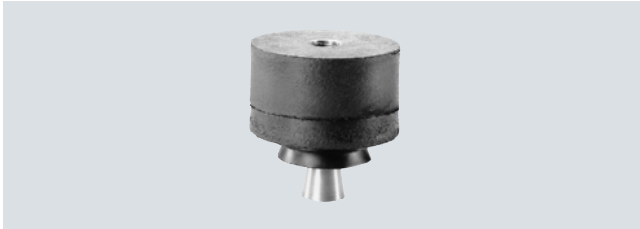

Elastomer bearing for SIWAREX WL280 RN-S SA load cells, 60 ... 280 kg (132.28 ... 617.29 lb)

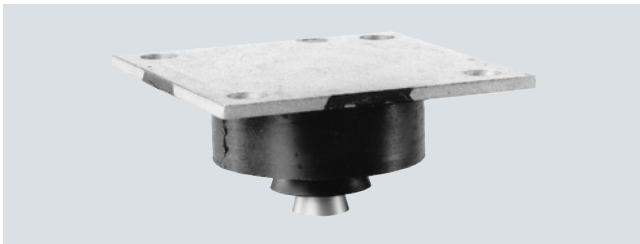

Elastomer bearing for SIWAREX WL280 RN-S SA load cells, 0.5 ... 13 t (0.49 ... 12.80 lb)

Used in combination with the self-aligning bearing base part, the self-centering elastomer bearing for SIWAREX WL280 RN-S SA load cells is the ideal load introduction element for scales without guide elements. It is used in container, platform and roller table scales and dampens vibrations and shocks.

## Design

Elastomer bearings are rubber-metal composites made of neoprene and stainless steel. They ensure large spring excursions (i.e. a high degree of damping) despite small dimensions.

If the load support is horizontally displaced by more than 4 mm (0.16 inch) or 6 mm (0.24 inch) for a rated load of 10 t (9.84 tn. L.) and 13 t (12.80 tn. L.), the design of the load support must include measures to restrict lateral play (e.g. limit stops). Lifting of the load support must be prevented by suitable measures provided in the construction of the load bearing implement.

The load cell and the self-aligning bearing bottom part are not included in the scope of delivery of the elastomer bearing.

## Selection and Ordering data

Order No.

Elastomer bearings<sup>1)</sup>

For SIWAREX WL280 RN-S SA load cells comprising: Elastomer package with fixing plate, force transfer, seal

Material: Stainless steel and neoprene

For load cells with a rated load of:

- |  |    |                      |
|--|----|----------------------|
| • 60, 130, 280 kg<br>(132.28, 286.60, 617.29 lb) |    | <b>7MH4130-3EE11</b> |
| • 0.5, 1 t (0.49, 0.98 tn. L.)                   | D) | <b>7MH4130-4AE11</b> |
| • 2, 3.5, 5 t (1.97, 3.44, 4.92 tn. L.)          | D) | <b>7MH4130-4KE11</b> |
| • 10, 13 t (9.84, 12.80 tn. L.)                  | D) | <b>7MH4130-5CE11</b> |

<sup>1)</sup> The load cell and the self-aligning bearing bottom part are not included in the scope of delivery.

D) Subject to export regulations AL: N, ECCN: EAR99H.

# Load cells

## SIWAREX WL200-SIWAREX WL280 RN-S SA

### Elastomer bearing

#### Dimensional drawings

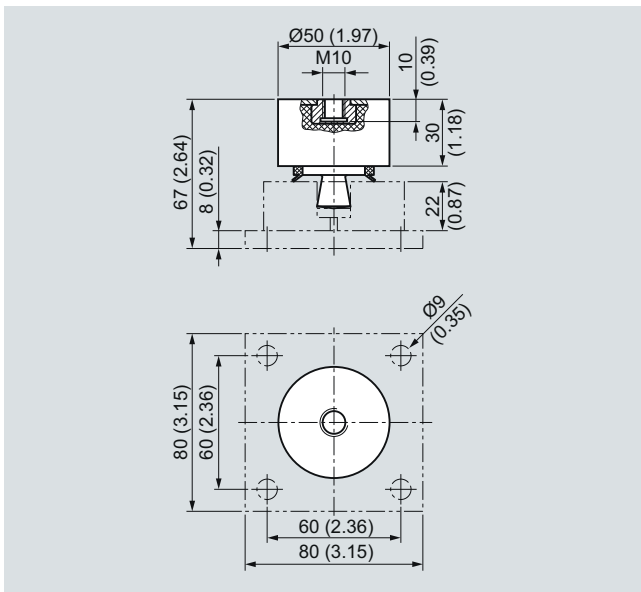

Elastomer bearing for SIWAREX WL280 RN-S SA load cell, 60 ... 280 kg (132.28 ... 617.30 lb), dimensions in mm (inch)

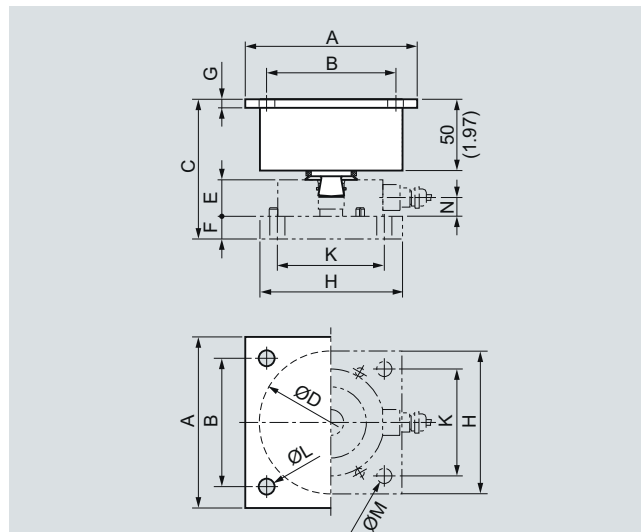

Rated load [t]	A	B	C	ØD	E	F
0, 5, 1	100 (3.94)	75 (2.95)	97 (3.82)	85 (3.35)	25 (0.98)	15 (0.59)
2, 3, 5, 5	120 (4.72)	90 (3.54)	102 (4.02)	100 (3.94)	30 (1.18)	15 (0.59)
10, 13	120 (4.72)	90 (3.54)	120 (4.72)	100 (3.94)	35 (1.38)	20 (0.79)

Rated load [t]	G	H	K	ØL	ØM	N
0, 5, 1	6 (0.24)	100 (3.94)	75 (2.95)	11 (0.43)	11 (0.43)	9.5 (0.37)
2, 3, 5, 5	6 (0.24)	100 (3.94)	75 (2.95)	11 (0.43)	11 (0.43)	8.5 (0.34)
10, 13	6 (0.24)	120 (4.72)	90 (3.54)	11 (0.43)	14 (0.55)	20 (0.79)

Elastomer bearing for SIWAREX WL280 RN-S SA load cell, 0,5 ... 13 t (0.49 ... 12.80 tn. L.), dimensions in mm (inch)

# Load cells

## SIWAREX WL200-SIWAREX WL280 RN-S SA

### Compact mounting unit

#### Overview

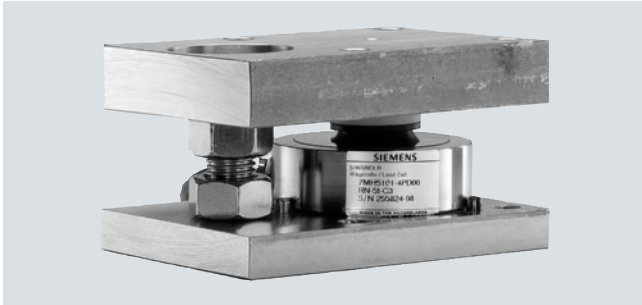

The self-aligning compact mounting unit for SIWAREX WL280 RN-S SA load cells is particularly suitable for implementation in container, platform and roller table scales due to its low constructional height.

#### Design

The compact mounting unit comprises a self-aligning bolt, a top plate and a base plate and one or two countersunk screws that serve as oscillation limitation and a protection against raising up.

The self-centering, self-aligning bolt allows the top plate, and thus the load support, to accommodate horizontal displacements (e.g. due to temperature fluctuations). The design of the self-aligning bolt creates a restoring force, which is dependent on the size of the displacement and the applied load. The oscillation limitation prevents excessive lateral displacement, thus

protecting the load cell against damage. It can accommodate a maximum horizontal force of  $F_h = 10 \text{ kN}$ . The max. lateral displacement is  $\pm 3 \text{ mm}$  (0.12 inch) (60 kg ... 5 t (132.28 lb ... 4.92 tn. L.)) or  $\pm 4.5 \text{ mm}$  (10 t (9.84 tn. L.)), 13 t (12.80 tn. L.)).

The protection against raising up prevents the load support from lifting against a maximum vertical force of  $F_v = 25 \text{ kN}$ .

The load cell is not included in the scope of delivery of the compact mounting unit.

#### Selection and Ordering data

Order No.

##### Compact mounting unit<sup>1)2)</sup>

For SIWAREX WL280 RN-S SA load cells

Material: Stainless steel

For load cells with a rated load of:

- 60, 130, 280 kg (132.28, 286.60, 617.29 lb) D) **7MH4125-3DA11**
- 0.5, 1 t (0.49, 0.98 tn. L.) D) **7MH4132-4AC11**
- 2, 3.5, 5 t (1.97, 3.44, 4.92 tn. L.) **7MH4132-4KC11**
- 10, 13 t (9.84, 12.80 tn. L.) **7MH4125-5BA11**

<sup>1)</sup> The load cell is not included in the scope of delivery.

<sup>2)</sup> It is highly recommendable to use a grounding cable (7MH3701-1AA1) in order to protect the load cell.

D) Subject to export regulations AL: N, ECCN: EAR99H.

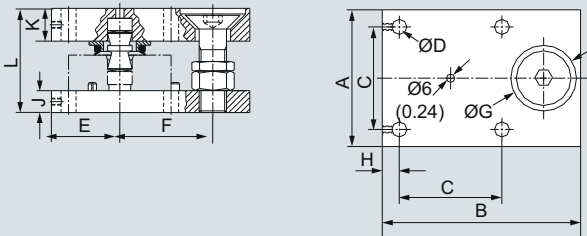

Rated load	A	B	C	ØD	E
60, 130, 280 kg	80 (3.15)	118 (4.65)	60 (2.36)	9 (0.35)	40 (1.57)
0,5, 1 t	100 (3.94)	145 (5.71)	75 (2.95)	11 (0.43)	50 (1.97)

Rated load	F	ØG	H	J	K	L
60, 130, 280 kg	57 (2.24)	39 (1.54)	10 (0.39)	8 (0.31)	12 (0.47)	52 (2.05)
0,5, 1 t	68 (2.68)	48 (1.89)	12.5 (0.49)	15 (0.59)	25 (0.98)	79 (3.11)

Compact mounting unit for SIWAREX WL280 RN-S SA load cell 60 ... 280 kg (132.28 ... 617.29 lb), dimensions in mm (inch)

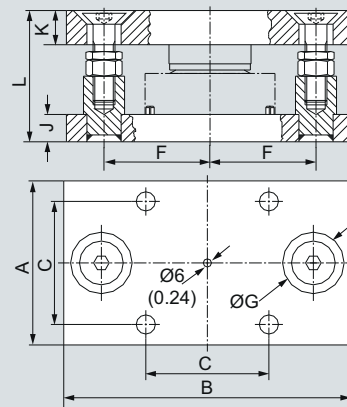

Rated load [t]	A	B	C	ØD	E
2, 3,5, 5	100 (3.94)	145 (5.71)	75 (2.95)	11 (0.43)	50 (1.97)
10, 13	100 (3.94)	190 (7.48)	75 (2.95)	11 (0.43)	-
	120 (4.72)	210 (8.27)	90 (3.54)	14 (0.55)	-

Rated load [t]	F	ØG	H	J	K	L
2, 3,5, 5	68 (2.68)	48 (1.89)	12,5 (0.49)	15 (0.59)	25 (0.98)	79 (3.11)
10, 13	68 (2.68)	48 (1.89)	-	15 (0.59)	25 (0.98)	79 (3.11)
	77,5 (3.05)	45 (1.77)	-	20 (0.79)	40 (1.57)	121,2 (4.77)

Compact mounting unit for SIWAREX WL280 RN-S SA load cell 2 ... 13 t (1.97 ... 12.80 tn. L.) dimensions in mm (inch)

# Load cells

## SIWAREX WL200-SIWAREX WL280 RN-S SA

### Guide element for compact mounting unit

#### Overview

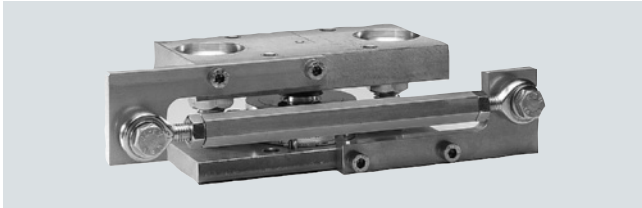

The guide element can be implemented in addition to the compact mounting unit for SIWAREX WL280 RN-S SA load cells. It is used when undesirable horizontal forces occur during the weighing process, e.g. due to mixing operations with container scales or acceleration of the material to be weighed with conveyor scales.

#### Design

The guide element consists of two ball joint heads, a spacer and two flanges for installation on the compact mounting unit.

The additive guide element can also be retrofitted on compact mounting units if unexpected lateral forces occur during operation of the scales and the compact mounting unit was installed in accordance with the requirements.

The guide element diverts horizontal forces up to 1.7 kN to the foundation and therefore minimizes effects on the load cells and the mounting components.

The load cell and compact mounting unit are not included in the scope of delivery of the guide element.

#### Dimensional drawings

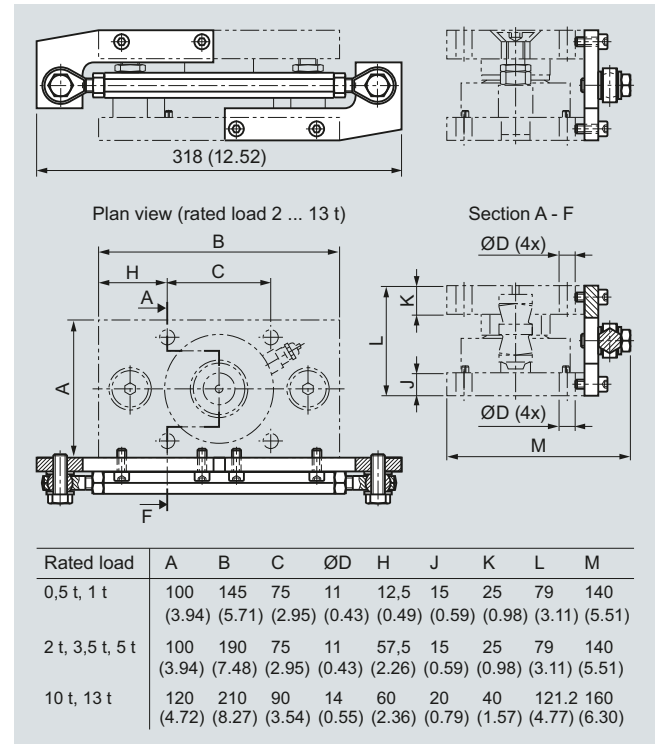

Guide element for compact mounting unit of SIWAREX WL280-S SA load cells, dimensions in mm (inch)

#### Selection and ordering data

Order No.

##### Guide element for compact mounting unit<sup>1)</sup>

for SIWAREX WL280 RN-S SA load cells

Consisting of: 2 flanges, 2 pivots,  
1 adapter, fixing elements

Material: Stainless steel

For load cells with a rated load of

- 0.5 t, 1 t (0.49, 0.98 tn. L.)    D) **7MH4132-4AQ12**
- 2 t, 3.5 t, 5 t (1.97, 3.44, 4.92 tn. L.)    D) **7MH4132-4KQ12**
- 10 t, 13 t (9.84, 12.80 tn. L.)    D) **7MH4134-5BQ12**

<sup>1)</sup> The load cell and compact mounting unit are not included in the scope of delivery.

D) Subject to AL export regulations: N, ECCN: EAR99H.



# Load cells

## SIWAREX WL200-accessories

SIWAREX JB junction box,  
Aluminum enclosure

### Overview



The aluminium JB junction box is required for parallel connection of load cells. A maximum of 4 load cells can be connected in parallel in one junction box.

If more than 4 load cells are to be connected, a second junction box must be connected in parallel via a cross connection. The junction box can be used in potentially explosive areas (grounded, intrinsically-safe circuits).

### Design

The junction box made of die-cast aluminum consists of a base section and a cover. The housing is sealed against penetration of dust and splashed water in accordance with IP 66 degree of protection. The cables enter the casing via metric cable glands. In the housing, there are 28 terminals with spring-mounted contacts. The spring-mounted system results in vibration-resistant, maintenance-free connections.

The internal resistance, characteristic value and nominal load of all load cells connected in parallel must be identical. The values of these variables are not limited by the junction box. Load cells can be connected using a four-wire or six-wire system.

With the four-wire system, two jumpers must be set in addition.

### Connection examples

#### 4 load cells

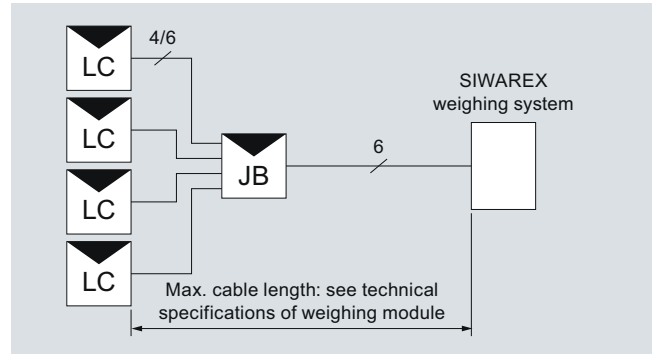

LC: load cell JB: aluminium junction box

#### 8 load cells

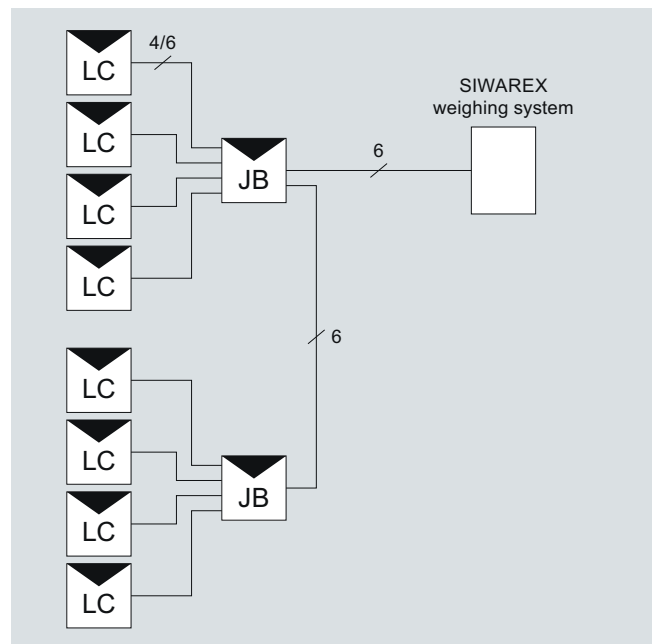

LC: load cell JB: aluminium junction box

### Technical specifications

#### SIWAREX JB junction box, aluminum enclosure

Cable glands	
• of load cells	4 x M16
• of signaling cable	2 x M20
Permissible ambient temperature	
• During operation	-30 ... +85 °C (-22 ... +185 °F)
• During operation for legal-for-trade medium accuracy weighing machines	-10 ... +40 °C (+14 ... +104 °F)
• During transportation and storage	-40 ... +90 °C (-40 ... +194 °F)
Degree of protection	IP66 to EN 60529
Vibration resistance of terminals to DIN VDE 0611 11/77	12 Hz and 50 Hz, amplitude 1 mm (0.04 inch)
Insulation resistance of terminals	$\geq 10^{12} \Omega$

# Load cells

## SIWAREX WL200-accessories

### SIWAREX JB junction box, Aluminum enclosure

#### Selection and Ordering data

Order No.

#### Accessories

#### SIWAREX JB junction box, aluminium housing

7MH4710-1BA

for connecting up to 4 load cells in parallel, and for connecting several junction boxes

#### Cable (optional)

#### Cable Li2Y 1 x 2 x 0,75 ST + 2 x (2 x 0,34 ST) - CY, orange sheath

7MH4702-8AG

to connect SIWAREX U, CS, MS, FTA, FTC and CF to the junction box (JB), extension box (EB) or Ex interface (Ex-I) or between two JBs, for fixed laying, occasional bending permitted, 10.8 mm (0.43 inch) outer diameter, for ambient temperature -40 to +80 °C (-40 ... +176 °F)

#### Cable Li2Y 1 x 2 x 0,75 ST + 2 x (2 x 0,34 ST) - CY, blue sheath

7MH4702-8AF

to connect the junction box (JB) or extension box (EB) in a potentially explosive atmosphere to the Ex interface (Ex-I), for fixed laying, occasional bending permitted, blue PVC insulating sheath, approx. 10.8 mm (0.43 inch) outer diameter, for ambient temperature -40 ... +80 °C (-40 ... +176 °F)

#### Dimensional drawings

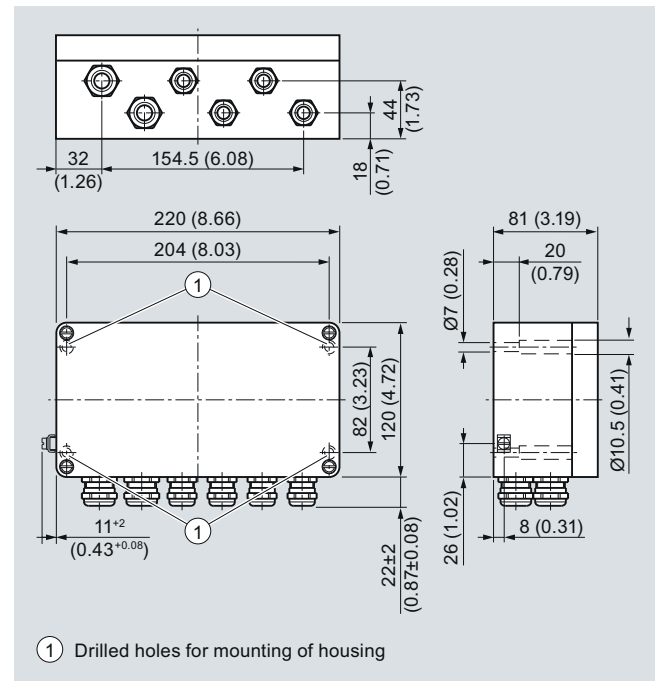

SIWAREX JB junction box in aluminum (7MH4710-1BA),  
dimensions in mm (inch)

# Load cells

## SIWAREX WL200-accessories

### SIWAREX JB junction box, Stainless steel enclosure

#### Overview



The stainless steel JB junction box is required for parallel connection of load cells. A maximum of 4 load cells can be connected in parallel in one junction box.

The junction box can be used in potentially explosive areas (grounded, intrinsically-safe circuits).

#### Design

The stainless steel junction box consists of a base section and a cover. The housing is sealed against penetration of dust and splashed water in accordance with IP 66 degree of protection. The cables enter the casing via metric EMC cable glands (brass, nickel-plated). In the housing, there are 18 terminals with spring-mounted contacts. The spring-mounted system results in vibration-resistant, maintenance-free connections.

The internal resistance, characteristic value and nominal load of all load cells connected in parallel must be identical. The values of these variables are not limited by the junction box. Load cells can be connected using a four-wire or six-wire system.

With the four-wire system, two jumpers must be set in addition.

#### Connection example

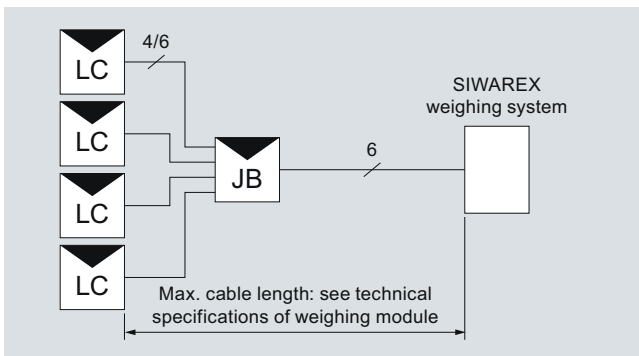

LC: load cell JB: stainless steel junction box

#### Technical specifications

##### SIWAREX JB junction box, stainless steel enclosure

Cable glands	
• of load cells	4 x M16
• of signaling cable	1 x M20
• Permissible ambient temperature	
• During operation	-30 ... +85 °C (-22 ... +185 °F)
• During operation for legal-for-trade medium accuracy weighing machines	-10 ... +40 °C (+14 ... +104 °F)
• During transportation and storage	-40 ... +90 °C (-40 ... +194 °F)
Degree of protection	IP66 to EN 60529
Vibration resistance of terminals to DIN VDE 0611 11/77	12 Hz and 50 Hz, amplitude 1 mm (0.04 inch)
Insulation resistance of terminals	$\geq 10^{12} \Omega \text{ cm}$

#### Selection and Ordering data

Order No.

Accessories	Order No.
<b>SIWAREX JB junction box, stainless steel housing</b> for connecting up to 4 load cells in parallel	<b>7MH4710-1EA</b>
<b>SIWAREX JB junction box, stainless steel housing, ATEX</b> For the parallel switching of up to 4 load cells Explosion protection for zones 1, 2, 20, 21 and 22	<b>7MH4710-1EA01</b>
<b>Cable (optional)</b>	
<b>Cable Li2Y 1 x 2 x 0,75 ST + 2 x (2 x 0,34 ST) - CY, orange sheath</b> to connect SIWAREX U, CS, MS, FTA, FTC and CF to the junction box (JB), extension box (EB) or Ex interface (Ex-I) or between two JB's, for fixed laying, occasional bending permitted, 10.8 mm (0.43 inch) outer diameter, for ambient temperature -40 to +80 °C (-40 ... +176 °F)	<b>7MH4702-8AG</b>
<b>Cable Li2Y 1 x 2 x 0,75 ST + 2 x (2 x 0,34 ST) - CY, blue sheath</b> to connect the junction box (JB) or extension box (EB) in a potentially explosive atmosphere to the Ex interface (Ex-I), for fixed laying, occasional bending permitted, blue PVC insulating sheath, approx. 10.8 mm (0.43 inch) outer diameter, for ambient temperature -40 ... +80 °C (-40 ... +176 °F)	<b>7MH4702-8AF</b>

# Load cells

## SIWAREX WL200-accessories

SIWAREX JB junction box,  
Stainless steel enclosure

### Dimensional drawings

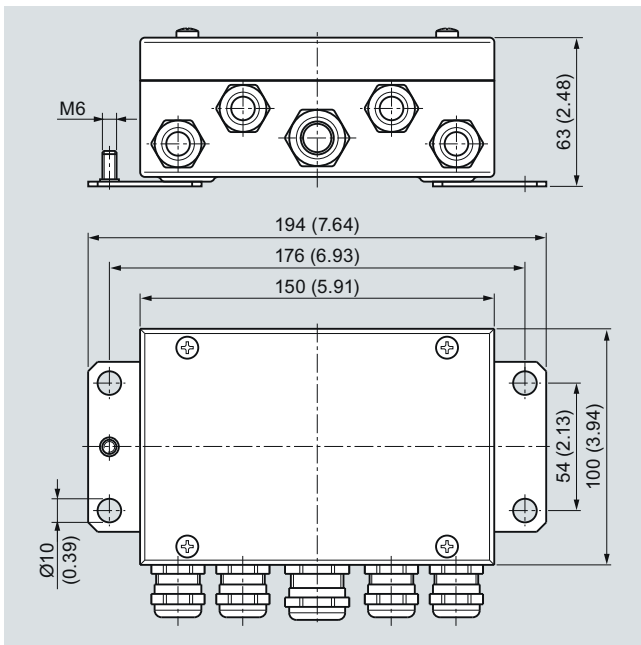

SIWAREX JB junction box in stainless steel (7MH4710-1EA),  
dimensions in mm (inch)

# Load cells

## SIWAREX WL200-accessories

### SIWAREX EB Extension box

#### Overview



The extension box EB serves to extend the connecting cable of the load cells.

It supports connection of 4-wire and 6-wire load cells. The cable connection to the weighing module or to the junction box JB must always be 6-wire. We recommend the 7MH4702-8AG or ...-8AF SIWAREX cable for connection.

If load cell cables to a junction box JB are extended, the JB's M16 x 1.5 cable glands will need replacing. The following is required for each load cell:

- 1 EMC cable gland, M20 x 1.5
- 1 extension M16 x 1.5 outer thread to M20 x 1.5 inner thread.

The extension box can be used in potentially explosive areas (grounded, intrinsically safe circuits).

#### Design

The extension box EB has a housing made of die-cast aluminium. The housing is sealed against penetration of dust and splashed water in accordance with IP66. The cables enter the casing via metric EMC cable glands and are connected to spring-mounted terminals. The spring-mounted system results in vibration-resistant, maintenance-free connections.

When connecting load cells with a 4-wire system, two jumper elements are inserted for feedback of the sense signal.

#### Connection examples

##### Connection of one load cell

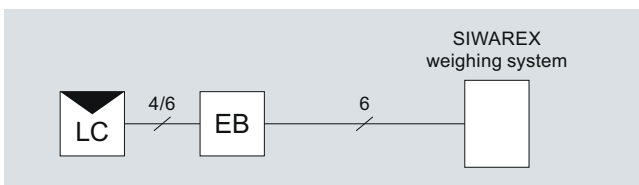

LC: Load cell EB: Extension box

##### Connection of several load cells

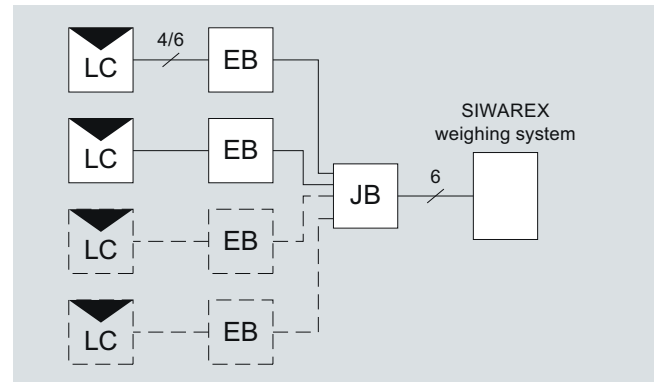

LC: Load cell EB: Extension box JB: Junction box

#### Technical specifications

##### SIWAREX EB, extension box

##### Cable glands

- of load cell cable M16 x 1.5
- of signaling cable M20 x 1.5

##### Permissible ambient temperature

- During operation -30 ... +85 °C (-22 ... +185 °F)
- During operation for legal-for-trade medium accuracy weighing machines -10 ... +40 °C (+14 ... +104 °F)
- During transportation and storage -40 ... +90 °C (-40 ... +194 °F)

##### Degree of protection to EN 60529

IP66

##### Vibration resistance of terminals to DIN VDE 0611 11/77

12 Hz and 50 Hz, amplitude 1 mm (0.04 inch)

##### Insulation resistance of the terminals

≥ 10<sup>12</sup> Ω

##### Dimensions

80 x 75 x 57 mm  
(3.15 x 2.95 x 2.24 inch)

# Load cells

## SIWAREX WL200-accessories

### SIWAREX EB Extension box Grounding cable

#### Selection and Ordering data Order No.

##### Accessories

**SIWAREX EB extension box, aluminum enclosure** **7MH4710-2AA**

for extending the connection cable of load cells

##### Cable (optional)

**Cable Li2Y 1 x 2 x 0.75 ST + 2 x (2 x 0.34 ST) - CY, orange sheath** **7MH4702-8AG**

to connect SIWAREX U, FTA, FTC and CS to the junction box (JB), extension box (EB) or Ex interface (Ex-I) or between two JB's, for fixed laying, occasional bending permitted, 10.8 mm (0.43 inch) outer diameter, for ambient temperature -40 to +80 °C (-40 ... +176 °F)

**Cable Li2Y 1 x 2 x 0.75 ST + 2 x (2 x 0.34 ST) - CY, blue sheath** **7MH4702-8AF**

to connect the junction box (JB) or extension box (EB) in a potentially explosive atmosphere to the Ex interface (Ex-I), for fixed laying, occasional bending permitted, blue PVC insulating sheath, approx. 10.8 mm (0.43 inch) outer diameter, for ambient temperature -40 ... +80 °C (-40 ... +176 °F)

#### Overview



The highly flexible grounding cable is used to discharge parasitic currents.

#### Design

The grounding cable is 400 mm (15.75 inch) long and represents an electrical parallel connection.

It protects the load cell against undesired voltages, such as those caused by welding or lightning strikes

We recommend using one grounding cable per load cell.

The load cell and/or other mounting elements are not included in the scope of delivery of the grounding cable.

#### Selection and Ordering data Order No.

**Grounding cable made of copper** **7MH3701-1AA1**

for discharging parasitic currents, length 400 mm (15.75 inch)

#### Dimensional drawings

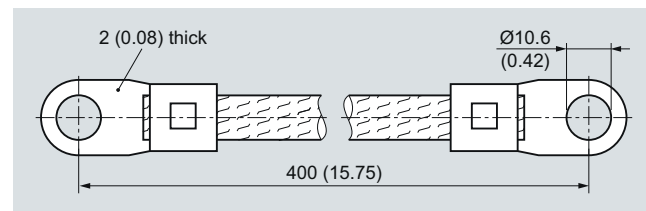

Grounding cable, dimensions in mm (inch)

#### Dimensional drawings

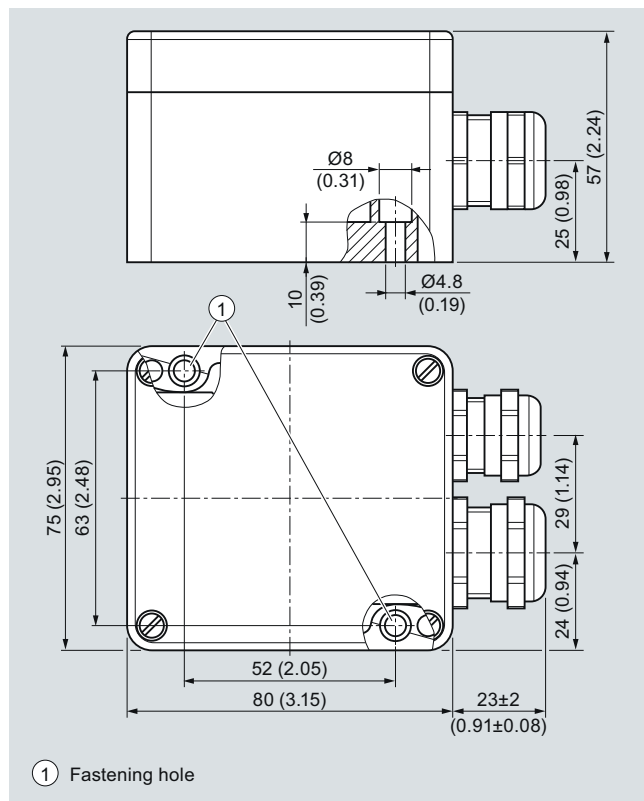

SIWAREX EB extension box (7MH4 710-2AA), dimensions in mm (inch)

### Overview

SIWAREX R load cells are equipped with strain gauges. They are used for static and dynamic weight measurements. The different series cover rated loads from 10 kg (22.05 lb) to 280 t (275.58 tn. L.). For technical specifications and ordering data, please refer to the overview tables.





# Load cells

## SIWAREX R

### Platform and Bending beam load cells

#### Overview

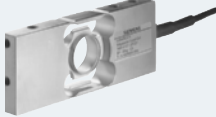
#### Technical specifications SIWAREX R load cells and mounting units

Design	Platform	Bending beam
Possible applications	Small platform scales Small conveyor scales	Container, conveyor and platform scales
Series	SP	BB
Pictures		
Rated load $E_{\max}$	6 ... 12 kg (13.23 ... 26.46 lb)	10 ... 350 kg (22.05 ... 771.62 lb)
Accuracy class	C3	C3
Max. load cell verification interval ( $n_{IC}$ )	3 000	3 000
Min. load cell verification interval ( $V_{\min}$ )	$E_{\max}/12\ 000$	$E_{\max}/15\ 000$
Supply voltage ( $U_{sr}$ )	5 ... 15 V	5 ... 15 V
Rated characteristic value	2 mV/V	2 mV/V
Degree of protection	IP66/IP68	IP66/IP68
Material	Stainless steel	Stainless steel
Ex protection according to ATEX (optional)	II 2 G EEx ib IIC T6/T4 II 3 G EEx nA/nL IIC T6/T4 II 1D/2D/3D T 70 °C (158 °F)	II 2 G EEx ib IIC T6/T4 II 3 G EEx nA/nL IIC T6/T4 II 1D/2D/3D T 70 °C (158 °F)
Mounting units	-	<ul style="list-style-type: none"> <li>• Base plate with overload protection</li> <li>• Elastomer bearings</li> <li>• Combination mounting units</li> </ul>



**Overview** (continued)**Selection and Ordering data SIWAREX R load cells and mounting units**

Platform	Order No.
<b>SP series</b>	<b>7MH4107-</b>
Legal-for-trade according to OIML R60 up to 3 000 d, connecting cable 7 m <sup>1)</sup>	■ ■ C ■ 1
<b>Rated load</b>	
• 6 kg (13.22 lb)	1 L
• 12 kg (26.46 lb)	2 B
<b>Explosion protection</b>	
Without	0
Explosion protection for zones 1, 2, 20, 21, 22	1
<sup>1)</sup> Length tolerance ± 100 mm (3.94 inch)	
Bending beam	Order No.
<b>BB series</b>	<b>7MH4103-</b>
Legal-for-trade according to OIML R60 up to 3 000 d, connecting cable 3 m <sup>1)</sup>	■ ■ C ■ 1
<b>Rated load</b>	
• 10 kg (22.05 lb)	2 A
• 20 kg (44.09 lb)	2 D
• 50 kg (110.23 lb)	2 K
• 100 kg (220.46 lb)	3 A
• 200 kg (440.92 lb)	3 D
• 350 kg (771.72 lb) <sup>2)</sup>	D) 3 G
<b>Explosion protection</b>	
Without	0
Explosion protection for zones 1, 2, 20, 21, 22	1
<b>Base plate with overload protection</b>	
for load cells in the BB series <sup>3)4)</sup>	
Material: Stainless steel	
For load cells with a rated load of:	
10 ... 200 kg (22.05 ... 440.92 lb)	D) 7MH4133-3DG11
<b>Elastomer bearings</b>	
for load cells in the BB series <sup>3)</sup>	
Material: Stainless steel	
For load cells with a rated load of:	
• 10 ... 50 kg (22.05 ... 110.23 lb)	D) 7MH4133-2KE11
• 10 ... 200 kg (22.05 ... 440.92 lb)	D) 7MH4133-3DE11
<b>Combination mounting units</b>	
for load cells in the BB series <sup>3)4)</sup>	
Material: Stainless steel	
For load cells with a rated load of:	
10 ... 200 kg (22.05 ... 440.92 lb)	D) 7MH4133-3DC11

<sup>1)</sup> Length tolerance ± 100 mm (3.94 inch)<sup>2)</sup> Installation accessories on request<sup>3)</sup> The load cell is not included in the scope of delivery.<sup>4)</sup> It is highly recommendable to use a grounding cable (7MH3701-1AA1) in order to protect the load cell.

D) Subject to export regulations AL: N, ECCN: EAR99H.

# Load cells

## SIWAREX R

### Shear beam load cells

#### Overview (continued)

#### Technical specifications SIWAREX R load cells and mounting units

Design	Shear beam
Possible applications	Container, conveyor, overhead rail and platform scales
Series	SB
Pictures	
Rated load $E_{\max}$	0.5 ... 5 t (0.49 ... 4.92 tn. L.)
Accuracy class	C3
Max. load cell verification interval ( $n_{IC}$ )	3 000
Min. load cell verification interval ( $V_{\min}$ )	$E_{\max}/10\ 000$
Supply voltage ( $U_{sr}$ )	5 ... 18 V
Rated characteristic value	2 mV/V
Degree of protection	IP66/IP68
Material	Stainless steel
Ex protection according to ATEX (optional)	II 2 G EEx ib IIC T6/T4 II 3 G EEx nA/nL IIC T6/T4 II 1D/2D/3D T 70 °C (158 °F)
Mounting units	<ul style="list-style-type: none"> <li>• Base plate with overload protection</li> <li>• Elastomer bearings</li> <li>• Combination mounting units</li> <li>• Guide element for combination mounting units</li> </ul>

**Overview** (continued)**Selection and Ordering data SIWAREX R load cells and mounting units**

Shear beam	Order No.
<b>SB series</b> Legal-for-trade according to OIML R60 up to 3 000 d, connecting cable 5 m <sup>1)</sup>	<b>7MH4105-</b> ■ ■ C ■ 1
<b>Rated load</b> • 500 kg (1102.31 lb) • 1 t (0.98 tn. L.) • 2 t (1.97 tn. L.) • 5 t (4.92 tn. L.)	3 K 4 A 4 D 4 K
<b>Explosion protection</b> Without Explosion protection for zones 1, 2, 20, 21, 22	0 1
<b>Base plate with overload protection</b> for load cells in the SB series <sup>2)3)</sup> Material: Stainless steel For load cells with a rated load of: • 0.5, 1, 2 t (0.49, 0.98, 1.97 tn.L.) • 5 t (4.92 tn. L.)	D) 7MH4135-4DG11 7MH4135-4KG11
<b>Elastomer bearings</b> for load cells in the SB series <sup>2)</sup> Material: Stainless steel For load cells with a rated load of: • 500 kg (1102.31 lb), 1 t (0.98 tn. L.) • 2 t (1.97 tn.L.) • 5 t (4.92 tn. L.)	D) 7MH4135-4AE11 D) 7MH4135-4DE11 D) 7MH4135-4KE11
<b>Combination mounting unit</b> for load cells in the SB series <sup>2)3)</sup> Material: Stainless steel For load cells with a rated load of: • 0.5, 1, 2 t (0.49, 0.98, 1.97 tn.L.) • 5 t (4.92 tn. L.)	D) 7MH4135-4DC11 D) 7MH4135-4KC11
<b>Guide element for combination mounting unit</b> for load cells in the SB series <sup>2)</sup> Material: Stainless steel For load cells with a rated load of: • 0.5, 1, 2 t (0.49, 0.98, 1.97 tn.L.) • 5 t (4.92 tn. L.)	D) 7MH4135-4DQ12 D) 7MH4135-4KQ12

1) Length tolerance ± 100 mm (3.94 inch)

2) The load cell is not included in the scope of delivery.

3) It is highly recommendable to use a grounding cable (7MH3701-1AA1) in order to protect the load cell.

D) Subject to export regulations AL: N, ECCN: EAR99H.

# Load cells

## SIWAREX R

### Bending ring load cells

#### Overview (continued)

#### Technical specifications SIWAREX R load cells and mounting units

Bending ring			
<b>Design</b>			
Possible applications	Container, conveyor and platform scales		
Series	RN		
Pictures			
Rated load $E_{max}$	60 ... 280 kg (132.28 ... 617.29 lb)	0,5 ... 10 t (0.49 ... 9.84 tn. L.)	13 ... 60 t (12.79 ... 59.05 tn. L.)
Accuracy class	C3	C3	C3
Max. load cell verification interval ( $n_{IC}$ )	3 000	3 000	3 000
Min. load cell verification interval ( $V_{min}$ )	$E_{max}/17\ 500$	$E_{max}/10\ 000$	$E_{max}/17\ 500$
Supply voltage ( $U_{sr}$ )	5 ... 30 V	5 ... 30 V	5 ... 30 V
Rated characteristic value	1 mV/V	2 mV/V	2 mV/V
Degree of protection	IP66/IP68	IP66/IP68	IP66/IP68
Material	Stainless steel	Stainless steel	Stainless steel
Ex protection according to ATEX (optional)	II 2 G EEx ib IIC T6/T4 II 3 G EEx nA/nL IIC T6/T4 II 1D/2D/ 3D T 70 °C (158 °F)	II 2 G EEx ib IIC T6/T4 II 3 G EEx nA/nL IIC T6/T4 II 1D/2D/ 3D T 70 °C (158 °F)	II 2 G EEx ib IIC T6/T4 II 3 G EEx nA/nL IIC T6/T4 II 1D/2D/ 3D T 70 °C (158 °F)
Mounting units	<ul style="list-style-type: none"> <li>• Elastomer bearing</li> <li>• Combination mounting unit</li> <li>• Guide element for combination mounting units</li> <li>• Self-aligning bearings</li> </ul>		

#### Selection and Ordering data SIWAREX R load cells and mounting units

Bending ring		Order No.				
<b>RN series</b>		<b>7MH5101-</b>				
Legal-for-trade according to OIML R60 up to 3 000 d, connecting cable 10 m <sup>1)</sup>		■	■	<b>D</b>	<b>0</b>	■
<b>Rated load</b>	<b>Cable length</b>					
• 60 kg (132.28 lb)	3 m (9.84 inch)	<b>2</b>	<b>Q</b>			
• 130 kg (286.60 lb)	3 m (9.84 inch)	<b>3</b>	<b>D</b>			
• 280 kg (617.29 lb)	3 m (9.84 inch)	<b>3</b>	<b>J</b>			
• 500 kg (1102.31 lb)	3 m (9.84 inch)	<b>3</b>	<b>P</b>			
• 1 t (0.98 tn. L.)	3 m (9.84 inch)	<b>4</b>	<b>A</b>			
• 2 t (1.97 tn. L.)	5 m (16.40 inch)	<b>4</b>	<b>G</b>			
• 3.5 t (3.45 tn. L.)	5 m (16.40 inch)	<b>4</b>	<b>L</b>			
• 5 t (4.92 tn. L.)	5 m (16.40 inch)	<b>4</b>	<b>P</b>			
• 10 t (9.84 tn. L.)	5 m (16.40 inch)	<b>5</b>	<b>A</b>			
• 13 t (12.80 tn. L.)	10 m (32.81 inch)	<b>5</b>	<b>D</b>			
• 28 t (27.56 tn. L.)	10 m (32.81 inch)	<b>5</b>	<b>J</b>			
• 60 t (59.05 tn. L.)	10 m (32.81 inch)	<b>5</b>	<b>Q</b>			
Without						<b>0</b>
Explosion protection for zones 1, 2, 20, 21, 22						<b>1</b>

## Overview (continued)

Bending ring	Order No.
<b>Self-aligning bearing top part<sup>2)4)</sup></b> for load cells in the RN series Consisting of: Top plate with seal holder and sealing ring, top plate pressure piece, self-aligning bolt, cell pressure piece (not for 28 t (27.56 tn. L.) and 60 t (59.05 tn. L.)) Material: Stainless steel For load cells with a rated load of: <ul style="list-style-type: none"> <li>• 60, 130, 280 kg (132.28, 286.60, 617.29 lb)</li> <li>• 0.5, 1 t (0.49, 0.98 tn. L.)</li> <li>• 2, 3.5, 5 t (1.97, 3.45, 4.92 tn.L.)</li> <li>• 10, 13 t (9.84, 12.80 tn. L.)</li> <li>• 28 t (27.56 tn. L.)</li> <li>• 60 t (59.05 tn. L.)</li> </ul>	D) <b>7MH4115-3DB11</b> D) <b>7MH4132-4AK11</b> D) <b>7MH4132-4KK11</b> D) <b>7MH4115-5BB11</b> D) <b>7MH4115-5DB11</b> D) <b>7MH4115-5GB11</b>
<b>Self-aligning bearing base part</b> for load cells in the RN series Consisting of: Base plate, 3 tension pins Material: Stainless steel For load cells with a rated load of: <ul style="list-style-type: none"> <li>• 60, 130, 280 kg (132.28, 286.60, 617.29 lb)</li> <li>• 0,5, 1; 2, 3.5, 5 t (0.49, 0.98; 1.97, 3.45, 4.92 tn. L.)</li> <li>• 10, 13 t (9.84, 12.80 tn. L.)</li> <li>• 28 t (27.56 tn. L.)</li> <li>• 60 t (59.05 tn. L.)</li> </ul>	D) <b>7MH4115-3DC11</b> D) <b>7MH4132-4AG11</b> D) <b>7MH4115-5BC11</b> D) <b>7MH4115-5DC11</b> D) <b>7MH4115-5GC11</b>
<b>Elastomer bearings</b> for load cells in the RN series <sup>2)4)</sup> Material: Stainless steel For load cells with a rated load of: <ul style="list-style-type: none"> <li>• 60, 130, 280 kg (132.28, 286.60, 617.29 lb)</li> <li>• 0.5, 1 t (0.49, 0.98 tn. L.)</li> <li>• 2, 3.5, 5 t (1.97, 3.45, 4.92 tn.L.)</li> <li>• 10, 13 t (9.84, 12.80 tn. L.)</li> </ul>	<b>7MH4130-3EE11</b> D) <b>7MH4130-4AE11</b> D) <b>7MH4130-4KE11</b> D) <b>7MH4130-4CE11</b>
<b>Combination mounting unit</b> for load cells in the RN series <sup>2)3)</sup> Material: Stainless steel For load cells with a rated load of: <ul style="list-style-type: none"> <li>• 60, 130, 280 kg (132.28, 286.60, 617.29 lb)</li> <li>• 0.5, 1 t (0.49, 0.98 tn. L.)</li> <li>• 2, 3.5, 5 t (1.97, 3.45, 4.92 tn.L.)</li> <li>• 10, 13 t (9.84, 12.80 tn. L.)</li> </ul>	D) <b>7MH4125-3DA11</b> D) <b>7MH4132-4AC11</b> <b>7MH4132-4KC11</b> <b>7MH4125-5BA11</b>
<b>Guide element for combination mounting unit</b> for load cells in the RN series <sup>2)</sup> Material: Stainless steel For load cells with a rated load of: <ul style="list-style-type: none"> <li>• 0.5, 1 t (0.49, 0.98 tn. L.)</li> <li>• 2, 3.5, 5 t (1.97, 3.45, 4.92 tn.L.)</li> <li>• 10, 13 t (9.84, 12.80 tn. L.)</li> </ul>	D) <b>7MH4132-4AQ12</b> D) <b>7MH4132-4KQ12</b> <b>7MH4134-5BQ12</b>

<sup>1)</sup> Length tolerance ± 100 mm (3.94 inch)

<sup>2)</sup> The load cell is not included in the scope of delivery.

<sup>3)</sup> It is highly recommendable to use a grounding cable (7MH3701-1AA1) in order to protect the load cell.

<sup>4)</sup> The self-aligning bearing base part is not included in the scope of delivery.

D) Subject to export regulations AL: N, ECCN: EAR99H.



# Load cells

## SIWAREX R

### Compression load cells

#### Overview (continued)

#### Technical specifications SIWAREX R load cells and mounting units

Design	Compression cell		
Possible applications	Container, hopper and vehicle scales		Container, hopper and vehicle scales
Series	CC		K
Pictures			
Rated load $E_{max}$	10 ... 60 t (9.84 ... 59.05 tn. L.)	100 t (98.42 tn. L.)	2.8 ... 280 t (2.76 ... 275.58 tn. L.)
Accuracy class	C3	C1	0.2 %
Max. load cell verification interval ( $n_{IC}$ )	3 000	1 000	-
Min. load cell verification interval ( $V_{min}$ )	$E_{max}/12\ 500$	$E_{max}/10\ 000$	-
Supply voltage ( $U_{sr}$ )	5 ... 25 V		6 ... 12 V
Rated characteristic value	2 mV/V		1.5 mV/V
Degree of protection	IP66/IP68		IP65
Material	Stainless steel		Steel, painted
Ex protection according to ATEX (optional)	II 2 G EEx ib IIC T6/T4 II 3 G EEx nA/nL IIC T6/T4 II 1D/2D/3D T 70 II 2 G EEx ib IIC T6/T4 II 3 G EEx nA /nL IIC T6/T4, II 1D / 2D / 3D T 70°C (158 °F)		-
Mounting units	<ul style="list-style-type: none"> <li>• Combination mounting units</li> <li>• Self-aligning bearings</li> </ul>	Self-aligning bearings	Self-aligning bearings

**Overview** (continued)**Selection and Ordering data SIWAREX R load cells and mounting units**

Pressure force		Order No.
<b>CC series</b>		<b>7MH4106-</b>
Legal-for-trade according to OIML R60 up to 3 000 d, connecting cable 3 m <sup>1)</sup>		■ ■ ■ ■ 1
<b>Rated load</b>	<b>Cable length</b>	
• 10 t (9.84 tn. L.)	10 m (32.81 inch)	5 A C
• 25 t (1.97 tn. L.)	20 m (65.62 inch)	5 E C
• 40 t (39.37 tn. L.)	20 m (65.62 inch)	5 H C
• 60 t (59.05 tn. L.)	20 m (65.62 inch)	5 L C
• 100 t (98.42 tn. L.)	20 m (65.62 inch)	6 A A
<b>Explosion protection</b>		
Without		0
Explosion protection for zones 1, 2, 20, 21, 22		1
<b>Self-aligning bearings</b>		
for load cells in the CC series <sup>1)2)</sup>		
Comprising a top plate, base plate and 3 pressure pieces		
Material: Stainless steel <sup>3)</sup>		
For load cells with a rated load of:		
• 10, 25 t (9.84, 24.61 tn. L.)		7MH4136-5EA11
• 40, 60 t (39.37, 59.05 tn. L.)		7MH4136-5LA11
• 100 t (98.42 tn. L.)		7MH4136-5AA11
<b>Combination mounting unit</b>		
for load cells in the CC series <sup>1)2)</sup>		
Material: Stainless steel <sup>3)</sup>		
For load cells with a rated load of:		
• 10, 25 t (9.84, 24.61 tn. L.)		D) 7MH4136-5EC11
• 40, 60 t (39.37, 59.05 tn. L.)		D) 7MH4136-5LC11
Pressure force		Order No.
<b>K series</b>		<b>7MH3105-</b>
Accuracy class 0.2 without explosion protection, connecting cable 5m <sup>4)5)</sup>		■ ■ C 0
<b>Rated load</b>	<b>Cable length</b>	
• 2.8 t (2.76 tn. L.)	5 m (16.40 inch)	2 A
• 6 t (5.91 tn. L.)	5 m (16.40 inch)	3 A
• 13 t (12.80 tn. L.)	10 m (32.81 inch)	1 B
• 28 t (27.56 tn. L.)	10 m (32.81 inch)	2 B
• 60 t (59.05 tn. L.)	10 m (32.81 inch)	3 B
• 130 t (127.95 tn. L.)	10 m (32.81 inch)	1 C
• 280 t (275.58 tn. L.)	10 m (32.81 inch)	2 C
<b>Pressure plate</b>		
for load cells in the K series <sup>1)2)</sup>		
To set up a self-aligning bearing, 2 pressure plates are required, one each at the top and bottom respectively Scope of supply: 1 pressure plate		
Material: Steel, painted		
For load cells with a rated load of:		
• 2.8, 6 t (2.76, 5.91 tn.L.)		7MH3115-3AA1
• 13 t (12.80 tn. L.)		D) 7MH3115-1BA1
• 28 t (27.56 tn. L.)		D) 7MH3115-2BA1
• 60 t (59.05 tn. L.)		D) 7MH3115-3BA1
• 130 t (127.95 tn. L.)		D) 7MH3115-1CA1
• 280 t (275.58 tn. L.)		D) 7MH3115-2CA1

1) The load cell is not included in the scope of delivery.

2) It is highly recommendable to use a grounding cable (7MH3701-1AA1) in order to protect the load cell.

3) Pressure pieces made of tool steel

4) Length tolerance ± 100 mm (3.94 inch)

5) Heat-resistant cable: -60 ... +180 °C (-76 ... +356 °C)

D) Subject to export regulations AL: N, ECCN: EAR99H.

# Load cells

## SIWAREX R

### SIWAREX R junction boxes

#### Overview (continued)

#### Technical specifications SIWAREX R accessories

##### SIWAREX JB junction box, aluminum, stainless steel SIWAREX EB, extension box

##### SIWAREX JB junction box, aluminum, stainless steel

Cable glands	
• Load cells	4 x M16
• Signal cable	2 x M20
Permissible ambient temperature	
• During operation	-30 ... +85 °C (-22 ... +185 °F)
• During operation for legal-for-trade medium accuracy weighing machines	-10 ... +40 °C (-14 ... +104 °F)
• During transportation and storage	-40 ... +90 °C (-40 ... +194 °F)
Degree of protection	IP66 to EN 60529
Vibration resistance of terminals to DIN VDE 0611 11/77	12 Hz and 50 Hz, amplitude 1 mm (0.04 inch)
Insulation resistance of terminals	$\geq 10^{12} \Omega$

##### SIWAREX JB junction box, aluminum, stainless steel SIWAREX EB, extension box

##### SIWAREX EB, extension box

Cable glands	
• Load cell cable	M16 x 1.5
• Signal cable	M20 x 1.5
Permissible ambient temperature	
• During operation	-30 ... +85 °C (-22 ... +185 °F)
• During operation for legal-for-trade medium accuracy weighing machines	-10 ... +40 °C (-14 ... +104 °F)
• During transportation and storage	-40 ... +90 °C (-40 ... +194 °F)
Degree of protection	IP66 to EN 60529
Vibration resistance of terminals to DIN VDE 0611 11/77	12 Hz and 50 Hz, amplitude 1 mm (0.04 inch)
Insulation resistance of terminals	$\geq 10^{12} \Omega$
Grounding cable	
Length	400 mm (15.75 inch)



## Overview (continued)

**Selection and Ordering data SIWAREX R accessories**

	Order No.
<b>SIWAREX JB junction box, aluminium housing</b> for connecting up to 4 load cells in parallel, and for connecting several junction boxes	<b>7MH4710-1BA</b>
<b>SIWAREX JB junction box, stainless steel housing</b> for connecting up to 4 load cells in parallel	<b>7MH4710-1EA</b>
<b>SIWAREX EB extension box, aluminum enclosure</b> for extending the connection cable of the load cells	<b>7MH4710-2AA</b>
<i>Cable (optional)</i>	
<b>Cable Li2Y 1 x 2 x 0,75 ST + 2 x (2 x 0,34 ST) - CY, orange sheath</b> to connect SIWAREX U, CS, MS, FTA, FTC, M and CF to the junction box (JB), extension box (EB) or Ex interface (Ex-I) or between two JBs, for fixed laying, occasional bending permitted, 10.8 mm (0.43 inch) outer diameter, for ambient temperature -40 to +80 °C (-40 ... +176 °F)	<b>7MH4702-8AG</b>
<b>Cable Li2Y 1 x 2 x 0.75 ST + 2 x (2 x 0.34 ST) - CY, blue sheath</b> to connect the junction box (JB) or extension box (EB) in a potentially explosive atmosphere to the Ex interface (Ex-I), for fixed laying, occasional bending permitted, blue PVC insulating sheath, approx. 10.8 mm (0.43 inch) outer diameter, for ambient temperature -40 ... +80 °C (-40 ... +176 °F)	<b>7MH4702-8AF</b>
<b>Grounding cable made of copper</b> for discharging parasitic currents 400 mm long (15.75 inch)	<b>7MH3701-1AA1</b>

# Load cells

## Configuration examples

### Introduction

#### Overview

##### **Number of load cells**

The three-point bearing is statically determined and offers a stable setup for any application.

If there are more than three bearing points, the load is likely to be unevenly positioned and, in extreme cases, that two diagonally positioned load cells would have to accommodate the entire load. Three-point bearing should therefore be used wherever possible.

To exclude the possibility of an uneven base, in the case of a bearing with more than three load cells, the prevailing weight distribution on the relevant load cells should be checked and a height adjustment performed if necessary. This can be achieved by using a suitable support to raise the load cells carrying less weight.

##### **Force bypass**

Force bypasses are produced if a partial load is transferred past the load cells into the base. There are various reasons for a force bypass (e.g. third-party supports, frictional forces, stresses, etc.).

Force bypasses must be avoided at all costs as they lead to measuring errors.

##### **Rated load of load cells**

The rated load is selected under maximum load, taking into account centers of gravity and load distribution on the individual load cells. The rated load is generally selected according to the most heavily loaded load cell. A check also needs to be performed to check if any dynamic forces are superimposed on the static load of the load cell. In this case, the rated load of the load cell must be calculated from the sum of the static load and the peak dynamic force.

##### **Example (please also refer to configuration example 1)**

Even load distribution without dynamic influences

Number of load cells	4
Empty weight of container	1.2 t (1.18 tn. L.)
Maximum capacity	1.8 t (1.77 tn. L.)
Total load:	3 t (2.95 tn. L.)

The 4 load cells are each loaded with 0.75 t (0.74 tn. L.) in order to ensure even load distribution. During configuration and selection of load cells, approx. 20 % should be added to the calculated rated load for safety reasons. This produces a required load cell rated load of  $0.75 \text{ t} \times 1.2 = 0.9 \text{ t}$  ( $0.74 \text{ tn. L.} \times 1.2 = 0.89 \text{ tn. L.}$ )

It therefore follows that it is necessary to select the next highest rated load level, with 1 t (0.98 tn. L.).

### More information

#### Example 1: Container weighing

The total center of gravity **S** of the suspended container lies above the level of the load cells.

It is supported on 4 brackets (container manufacturer specification), has an empty weight (i.e. dead load) of 1.2 t (1.18 tn. L.) and a maximum capacity of 1.8 t (1.77 tn. L.). The load is evenly distributed across all 4 load cells.

#### Note

The three-point bearing of the container is statically determined and represents a stable state (see comment in the introduction, page 3/66).

#### Selection of load cells and mounting components

The determination of the rated load, as described in the introduction, leads to a rated load of 1 t (0.98 tn. L.).

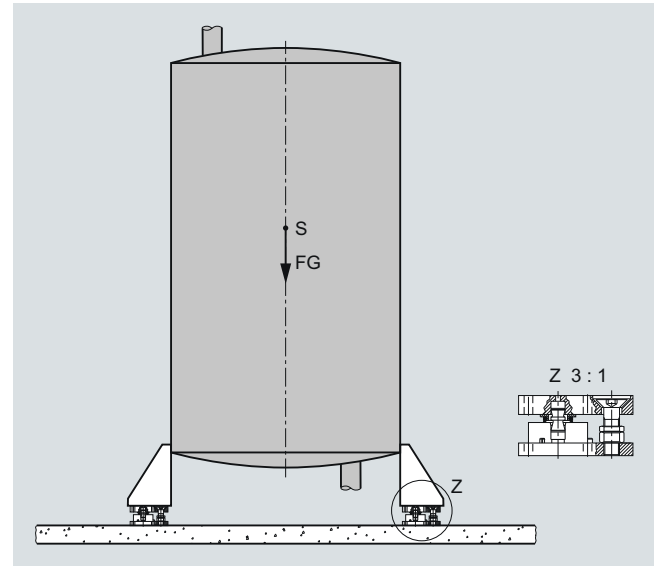

Container on SIWAREX WL280 RN-S SA load cells and compact mounting units

For the above example, 4 SIWAREX WL280 RN-S SA load cells were used with a rated load of 1 t (0.98 tn. L.) because the high-quality precision RN load cells have an extremely low constructional height.

Self-centering compact mounting units are used as mounting components as, in addition to their oscillation function and oscillation limitation, they are also fitted with a protection against raising up. The protection against raising up can handle a maximum vertical force of 10 kN. In the event of greater lifting forces (e.g. due to wind load), the container must be safeguarded with additional catastrophe protection.

#### Configurator for container weighing (basic configuration)

Item	Description	Order number	Selection criterion	Number in example
1	SIWAREX WL280 RN-S SA, rated load 1 t (0.98 tn. L.), C3	<b>7MH5113-4AD00</b>	High-quality ring-torsion load cell with low constructional height, ideal for container weighing	4
2	Compact mounting unit for SIWAREX WL280 RN-S SA load cell, rated load 1 t (0.98 tn. L.), Material: Stainless steel	<b>7MH4132-4AC11</b>	Ensures not only the oscillation function with oscillation limitation, but also the protection against raising up function	4
3	Grounding cable	<b>7MH3701-1AA1</b>	For discharging undesirable currents	4

# Load cells

## Configuration examples

### Configuration example 2

#### More information

##### Example 2: Container weighing

The total center of gravity **S** of the suspended container lies below the level of the load cells.

It is supported on 3 brackets, has an empty weight (i.e. dead load) of 1.2 t and a maximum capacity of 1.8 t. The container has a diameter of 1 m (3.3 ft). Weighing of the individual components produces a chemical reaction that raises the temperature of the container with contents from approx. 18°C to approx. 55° C (131° C).

##### Selection of load cells and mounting components

We recommend using 3 SIWAREX WL280 RN-S SA load cells with a rated load of 2 t (1.97 tn. L.) (for determination of the rated load: please refer to introduction, page 3/66). Due to its low constructional height, the WL280 RN load cell was used.

Self-centering self-aligning bearings are used as mounting components as the container is suspended and cannot lift up from the self-aligning bearing.

The 37 K temperature rise will cause the diameter of the container to increase by 0.4 mm (0.02 inch).

The self-aligning bearing permits a maximum oscillation path of  $\pm 4$  mm (0.16 inch) and is therefore able to accommodate the temperature expansion of the container.

An oscillation limitation is not necessary because there is a small gap of  $b = 3$  mm (0.12 inch) between the container and the platform. In this case, the platform acts as an oscillation limitation.

If the width of the gap is larger in other applications, it may be necessary to install compact mounting units (instead of the self-aligning bearing) or alternatively, external oscillation limiters (see configuration example 4).

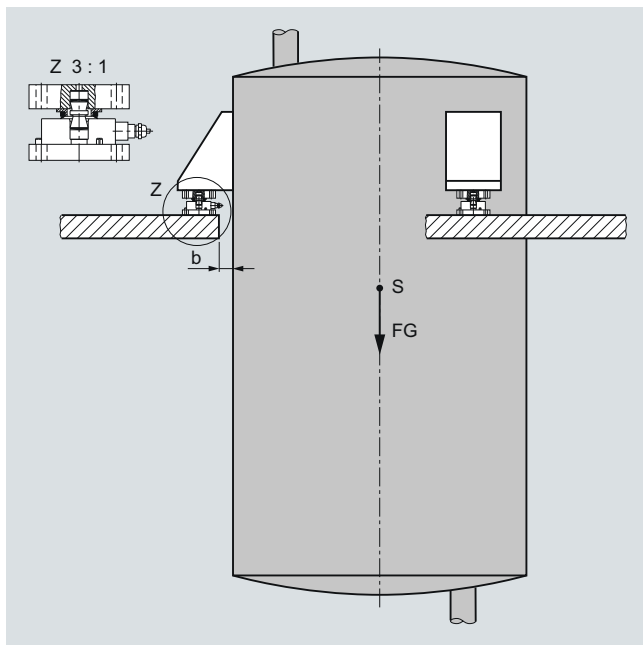

Container weighing with SIWAREX WL280 RN-S SA load cell and self-aligning bearing

##### Configurator for container weighing (basic configuration)

Item	Description	Order number	Selection criterion	Number in example
1	SIWAREX WL280 RN-S SA, rated load 2 t (1.97 tn. L.), C3	<b>7MH5113-4GD00</b>	High-quality ring-torsion load cell with low constructional height, ideal for container weighing	3
2	Self-aligning bearing base part for SIWAREX WL280 RN-S SA load cell, rated load 2 t (1.97 tn. L.) Material: Stainless steel	<b>7MH4132-4AG11</b>	Supports accommodation of temperature expansion, without transferring interfering reaction forces to the load cell	3
3	Self-aligning bearing top part for SIWAREX WL280 RN-S SA load cell, rated load 2 t (1.97 tn. L.) Material: Stainless steel	<b>7MH4132-4KK11</b>		
4	Grounding cable	<b>7MH3701-1AA1</b>	For discharging undesirable currents	3

#### More information

##### Example 3: Mixer weighing

The total center of gravity **S** of the suspended container lies below the level of the load cells.

It is supported on 3 brackets, has an empty weight (i.e. dead load) of 2.8 t (2.76 tn. L.) and a maximum capacity of 4.5 t (4.43 tn. L.).

To improve mixing of the individual components, an agitator is mounted on the container which also operates during the weighing process.

##### Selection of load cells and mounting components

We recommend using 3 SIWAREX WL280 RN-S SA load cells with a rated load of 3.5 t (3.45 tn. L.) because the high-quality precision WL280 RN load cell has an extremely low constructional height (for determination of rated load: please refer to introduction, page Seite 66)

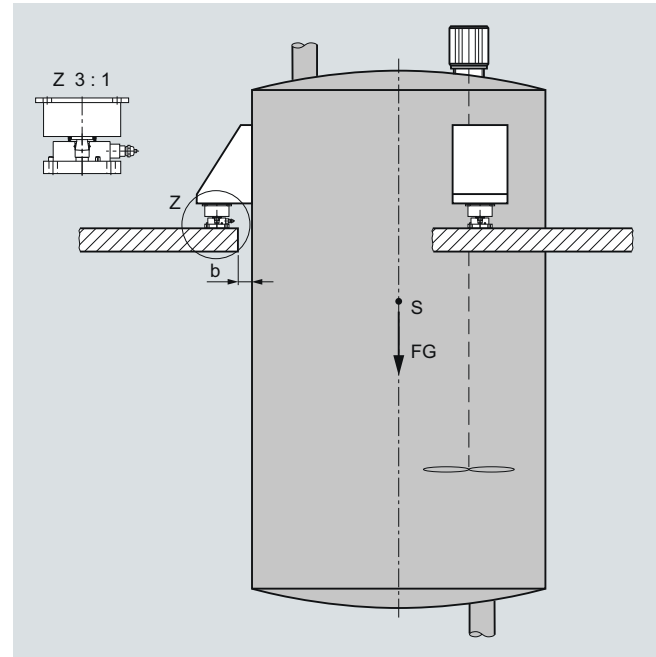

Container with agitator on SIWAREX WL280 RN-S SA load cell and elastomer bearing

Self-centering elastomer bearings are used as the mounting components to minimize the vibrations caused by the mixer.

The elastomer bearing permits a maximum oscillation path of  $\pm 4$  mm (0.16 inch).

An oscillation limitation is not necessary because there is a small gap of  $b = 3$  mm (0.12 inch) between the container and the platform.

If the width of the gap is larger in other applications, limit stops or external oscillation limiters must be provided.

#### Configurator for mixer weighing (basic configuration)

Item	Description	Order number	Selection criterion	Number in example
1	SIWAREX WL280 RN-S SA, rated load 3.5 t, C3, without EEx	7MH5113-4LD00	High-quality ring-torsion load cell with low constructional height, ideal for container weighing	3
2	Self-aligning bearing base part for SIWAREX WL280 RN-S SA load cell, rated load 2 t (1.97 tn. L.) Material: Stainless steel	7MH4132-4AG11		3
3	Elastomer bearing for SIWAREX WL280 RN-S SA load cell, rated load 2 t (1.97 tn. L.) Material: Neoprene and stainless steel	7MH4130-4KE11	For vibration damping to minimize the effects on the load cell	3
4	Grounding cable	7MH3701-1AA1	For discharging undesirable currents	3

# Load cells

Notes

3