

Catalog D 86.1 • 2005



# ac motors LARGE DRIVES



Asynchronous Motors  
Standardline

N-compact 1LA8  
H-compact 1LA4

**SIEMENS**



## Catalogs for „Large Drives“

### SINAMICS G130/G150

D 11

Drive Converter Chassis Units  
Drive Converter Cabinet Units  
Order No.:  
German: E86060-K5511-A101-A2  
English: E86060-K5511-A101-A2-7600

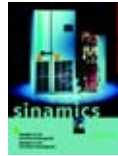

### Low-Voltage Motors Sizes 56 to 450

M 11

Output 0.06 kW to 1000 kW  
Order No.:  
German: E86060-K1711-A101-A3  
English: E86060-K1711-A101-A3-7600

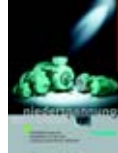

### SIMOVERT MV Medium-Voltage Drives 660 kVA to 9100 kVA

DA 63

Order No.:  
German: E86060-K5363-A101-A2  
English: E86060-K5363-A101-A2-7600



### Components for Automation

CA 01

Order No.:  
German: E86060-D4001-A100-C3  
English: E86060-D4001-A110-C3-7600



### A&D Mail

Internet:  
[www.siemens.com/automation/maill](http://www.siemens.com/automation/maill)



## Energy-saving program SinaSave™

Energy is valuable. Electrical power is the most important resource in industry and ensures that motors run, machines operate and plants manufacture.

Our SinaSave software tool can show you how fast an investment in an EFF1 energy-saving motor or a frequency drive amortizes. Based on your plant characteristics, the program determines how much energy you'll save in the specific application case. The amortization period is calculated based on the overall monthly savings and the purchase price of the motor or frequency drives. The amortization period often lasts for just a few months.

The SinaSave energy-saving program has been developed for applications with motors in direct online operation (fixed speed) and in frequency drive operation (variable speed). With fixed speed, cost savings and payback time of the higher motor price for Siemens EFF1 energy-saving motors can be calculated based on the following three cases. Compared to...

- Siemens EFF2 energy-saving motors - **Case 1**
- Individually selected known motors - **Case 2**
- Known motors within the framework of a complete plant analysis - **Case 3**

With variable speed, SinaSave considers all required system-specific parameters. Values required for the process are considered, such as flow rate and delivery head of pumps, mass flow rate and total pressure drop on fans and the density of the delivered medium, as well as the efficiency of the pumps and compressors, the electrical efficiency and the overall efficiency of the plant. Further basic data used by the program is the number of workdays and work shifts as well as the daily and annual output profile, which is decisive with respect to the energy savings effect.

First of all, the program uses the plant-specific basic data entered, to determine the drive system with the required output, and the price of a suitable frequency drive. In another step, the program determines the energy demand of the variable-speed drive system for the specific application and compares it with the calculated values of all possible alternative concepts for the respective plant, such as throttle valves, bypass, pre-rotation control or pole-changing motors. Energy savings in kilowatt hours are derived from the resulting difference. The program converts this difference into actual cash value based on the currently valid power supply price for the plant.

The program calculates the payback period considering the price of the frequency drives, the decisive energy savings, and other cost-cutting effects of the variable-speed operation, such as improved power factor and machine-friendly operation.

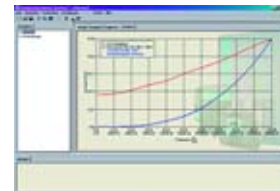

### Further information and download of SinaSave:

[www.siemens.com/energysaving](http://www.siemens.com/energysaving)

## Trademarks

All designations marked in this catalog with ® are registered trademarks of Siemens AG.

Other designations used in this document may be trademarks; the owner's rights may be violated if they are used by third parties for their own purposes.

# Asynchronous Motors Standardline

N-compact 1LA8  
H-compact 1LA4

Catalog D 86.1 · 2005



The products in this catalog (except for High-Voltage Motors) are also included in the electronic catalog CA 01 on CD-ROM Order No.: E86060-D4001-A110-C3-7600

Contact your local Siemens representative for further information

© Siemens AG 2005



*The products and systems described in this catalog are manufactured/distributed under application of a certified quality management system in accordance with DIN EN ISO 9001. The certificate is recognized by all IQNet countries.*



# SIEMENS

## Introduction

Products of A&D  
Overview and preselection of Standardline three-phase AC asynchronous motors

1

## Low-Voltage Motors N-compact

Operation on supply system

### Standardline

2

Operation with converter

3

## High-Voltage Motors H-compact

Operation on supply system

### Standardline

4

## Appendix

Contacts  
A&D Online Services  
Service & Support  
Conditions of sale and delivery

5

## Welcome to Automation and Drives

We would like to welcome you to Automation and Drives and our comprehensive range of products, systems, solutions and services for production and process automation and building technology worldwide.

With Totally Integrated Automation and Totally Integrated Power, we deliver solution platforms based on standards that offer you a considerable savings potential.

Discover the world of our technology now. If you need more detailed information, please contact one of your regional Siemens partners.

They will be glad to assist you.





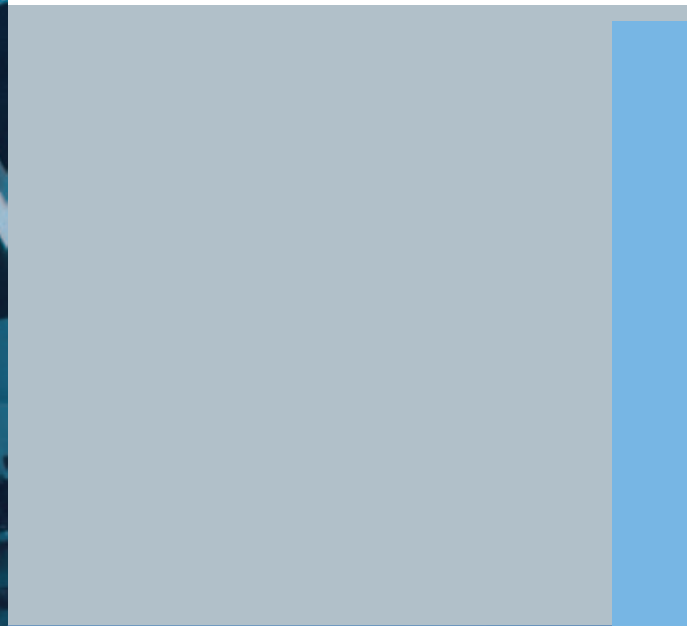

# Totally Integrated Automation – innovations for more productivity

With the launch of Totally Integrated Automation, we were the first ones on the market to consistently implement the trend from equipment to an integrated automation solution, and have continuously improved the system ever since. Whether your industry is process- and production-oriented or a hybrid, Totally Integrated Automation is a unique "common solution" platform that covers all the sectors. Totally Integrated Automation is an integrated platform for the entire production line - from receiving to technical processing

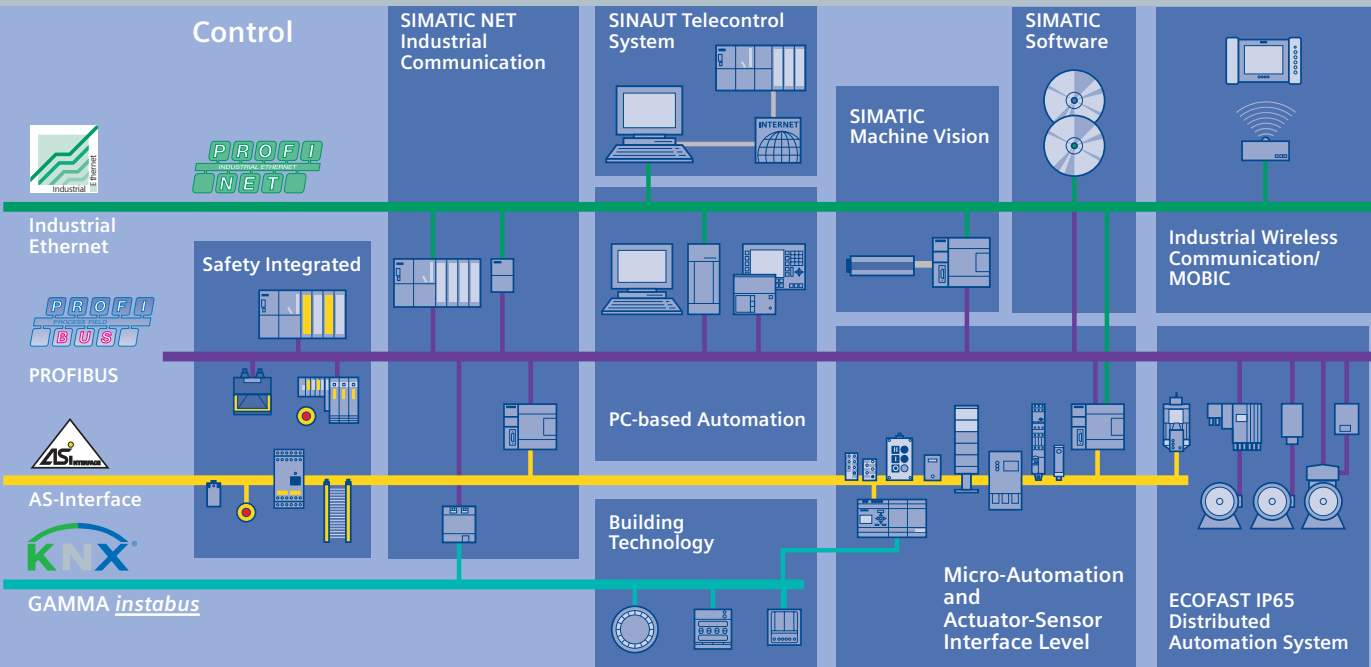
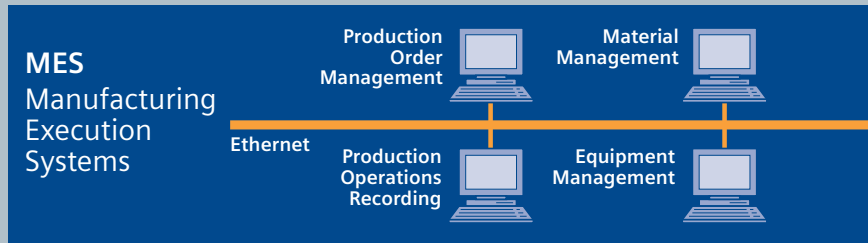

and production areas to shipping. Thanks to the system-oriented engineering environment, integrated, open communications as well as intelligent diagnostics options, your plant now benefits in every phase of the life cycle. In fact, to this day we are the only company worldwide that can offer a control system based on an integrated platform for both the production and process industry.

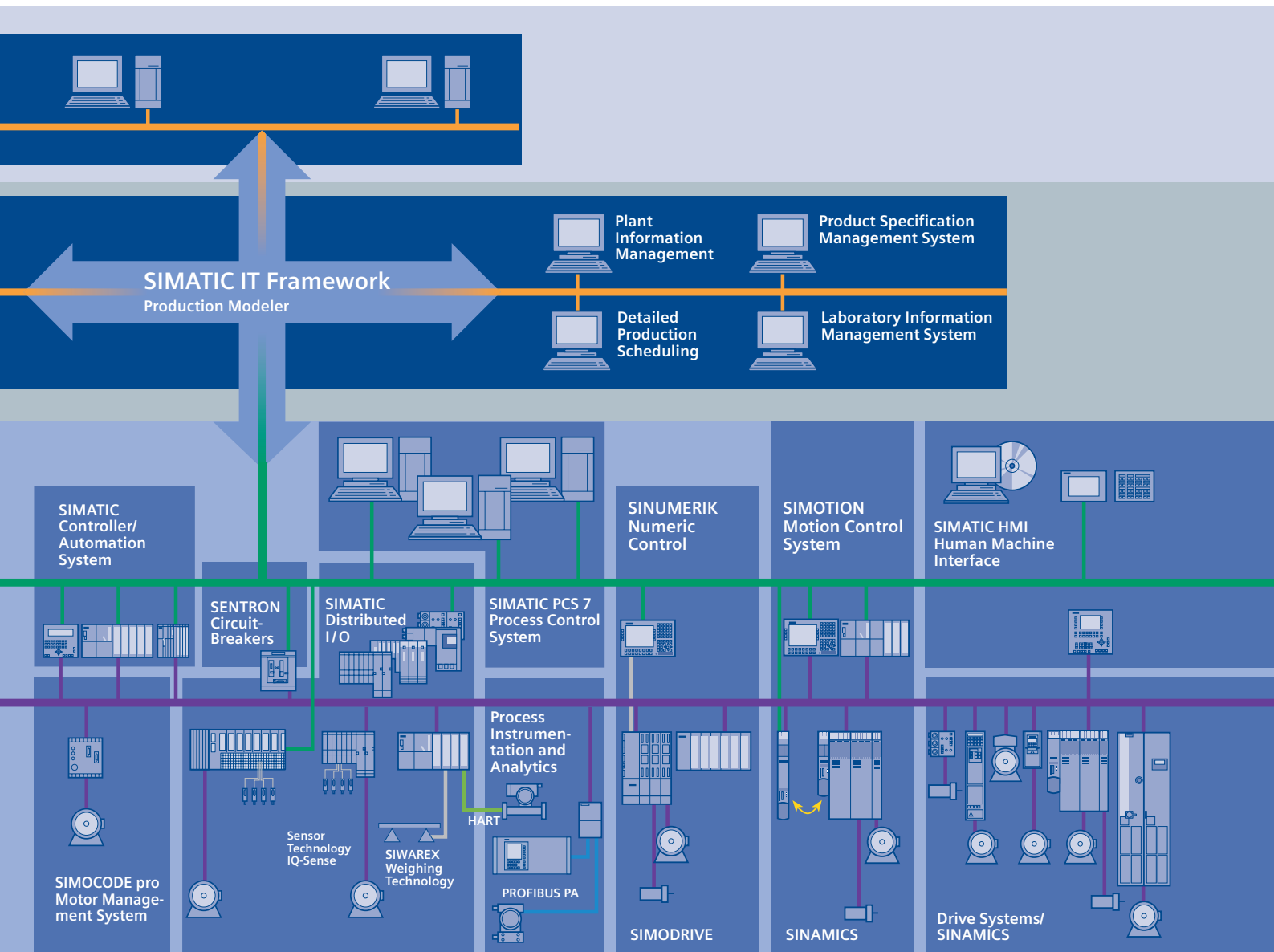

# Totally Integrated Power – energy distribution and management from one source

Totally Integrated Power™ by Siemens offers integrated solutions for energy distribution in functional and industrial buildings covering everything from medium-high voltage to power outlets.

Totally Integrated Power™ is based on integration in planning and configuration as well as coordinated products and systems. In addition, it features communications and software modules for connecting power distribution systems to industrial automation and building automation, thereby offering a substantial savings potential.

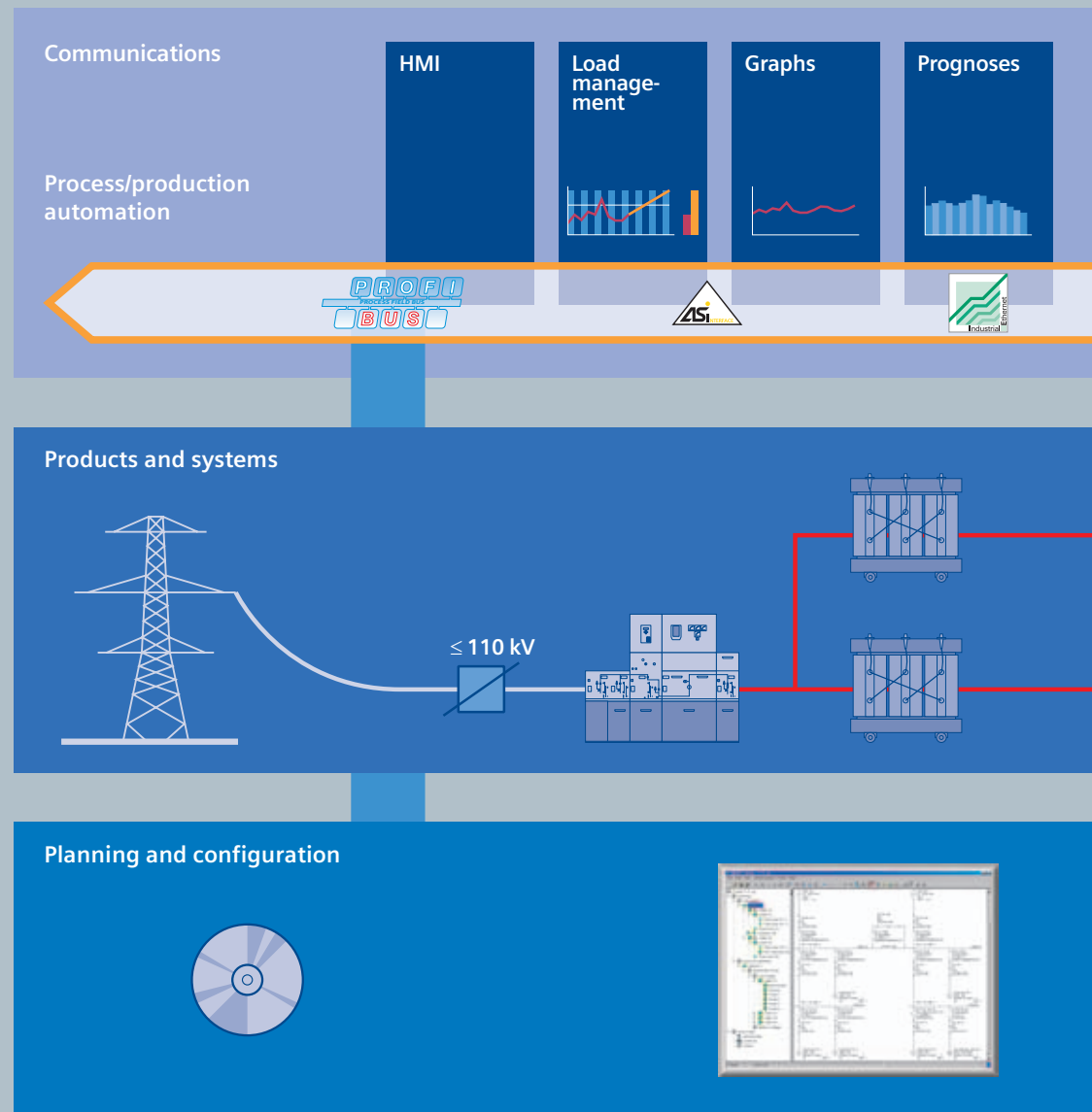



### Maintenance

- Substation
- Distribution
- Maintenance task

Hall 1 Air conditioning system  
checkup  
Distribution 3 Replacing circuit  
breaker contacts  
Infeed II Replacing meters

### Message/ error management



### Selective protection



### Protocols

Protocol	Device	Address	Function
BACnet	1	100	Temperature sensor
	2	101	Temperature sensor
	3	102	Temperature sensor
	4	103	Temperature sensor
KNX	1	100	Light switch
	2	101	Light switch
	3	102	Light switch
	4	103	Light switch
EIB	1	100	Light switch
	2	101	Light switch
	3	102	Light switch
	4	103	Light switch

### Power quality

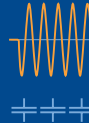

### Cost center



Building  
automation

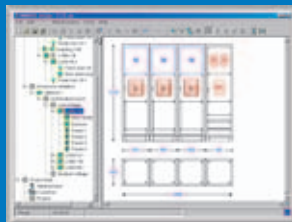
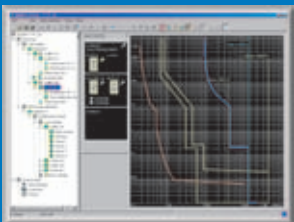
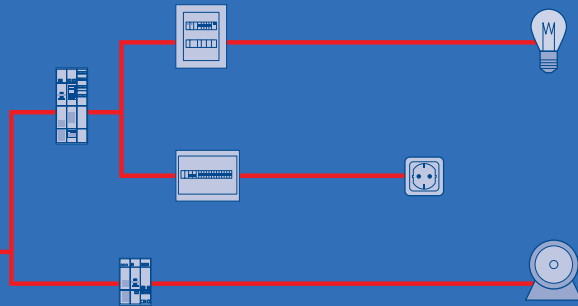
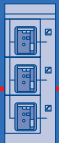
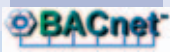

## Asynchronous Motors Standardline

### Overview

Complete drive systems can be selected and configured simply in this catalog.

The following variants of Standardline N-compact and H-compact motors are available:

- Type of construction: IM B3
- Degree of protection: IP55
- Cooling method: IC 411

Motor	Operation	Rated voltage	Power range	Pole number	Catalog section
<b>N-compact 1LA8 low-voltage</b>	<b>on supply system</b>	400 V $\Delta$ /690 V $\Upsilon$ , 50 Hz 500 V $\Delta$ , 50 Hz	250 ... 500 kW	4-pole	<b>2</b>
	<b>with SINAMICS G150 converter</b>	400 V $\Delta$ , 50 Hz 400 V $\Delta$ /690 V $\Upsilon$ , 50 Hz 500 V $\Delta$ , 50 Hz	250 ... 500 kW	4-pole	<b>3</b>
<b>H-compact 1LA4 high-voltage</b>	<b>on supply system</b>	3.0 kV, 50 Hz 3.3 kV, 50 Hz 6.0 kV, 50 Hz 6.6 kV, 50 Hz	200 ... 800 kW	2-pole, 4-pole and 6-pole	<b>4</b>

### Benefits

#### *Standardline – large-drive technology kept simple*

The Standardline range provides a family of high-voltage and low-voltage motors which have been standardized to minimize product complexity.

Benefits to the customer:

- Sophisticated technology - available quickly and at low prices
- Products in the Standardline range can be configured with a variety of options so as to ensure a high degree of flexibility.

### Application

Standardline high-voltage and low-voltage motors are ideally designed for application in pump, fan and compressor drives.

The low-voltage motors are specially constructed for use in complete, coordinated drive systems comprising the motor and a SINAMICS G150 frequency converter.

### More information

#### *H-compact*

- in Sales Brochures:
  - H-compact  
Maximum power, minimum size  
Order No. E20001-A100-P530-X-7600
  - H-compact Standardline  
Outstanding performance, short delivery time  
Order No. E20001-A130-P530-X-7600
- in Catalog DA 63:  
Order No. E86060-K5363-A101-A2-7600
- on the Internet: [www.siemens.com/h-compact](http://www.siemens.com/h-compact)

#### *N-compact*

- in Sales Brochures:
  - N-compact  
Higher performance and cost-effectiveness with outstanding reliability  
Order No. E20001-A80-P530-X-7600
  - N-compact Standardline  
Proven technology at an attractive price  
Order No. E20001-A90-P530-X-7600
- in Catalog M 11:  
Order No. E86060-K1711-A101-A3-7600
- on the Internet: [www.siemens.com/n-compact](http://www.siemens.com/n-compact)
- in Online Catalog CA01: [www.ad.siemens.com/ca01](http://www.ad.siemens.com/ca01)

#### *SINAMICS G150*

- in the System Overview:  
SINAMICS - The New Drive Family  
Order No. 6ZB5471-0AB02-0BA2
- in Catalog D 11:  
Order No. E86060-K5511-A101-A2-7600
- on the Internet: [www.siemens.com/sinamics-g150](http://www.siemens.com/sinamics-g150)

# Low-Voltage Motors N-compact **Standardline** Operation on supply system

# 2



<b>2/2</b>	<b>Overview</b>
<b>2/2</b>	<b>Benefits</b>
<b>2/2</b>	<b>Technical specifications</b>
<b>2/2</b>	<b>Selection and Ordering Data</b>
<b>2/3</b>	<b>Options</b>
<b>2/3</b>	<b>Dimensional drawings</b>
<b>2/4</b>	<b>More information</b>
2/4	Power cables



# Low-Voltage Motors N-compact Standardline

## Operation on supply system

### Overview

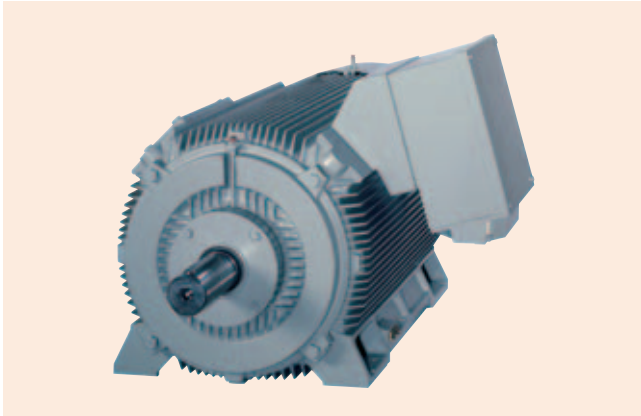

The N-compact series sets the modern worldwide standard for large three-phase low-voltage motors. Many details of the motors' design make them durable and so robust that they are always capable of withstanding extreme stresses.

In terms of technical design, the N-compact Standardline series is identical to the familiar 1LA8 N-compact motors which are described in Catalog M 11 (Order No. E86060-K1711-A101-A3-7600).

Standardline is intentionally designed to focus the N-compact series on meeting the requirements of drives for pumps, fans and compressors:

- Power range 250 to 500 kW
- Supply voltages 400 V, 500 V and 690 V at a frequency of 50 Hz
- 4-pole
- Type of construction IM B3

### Benefits

Standardization has made it possible to further optimize order handling and production processes.

Benefits to the customer:

- Significant reduction in delivery time to only 4 weeks
- Attractive price
- State-of-the-art technology and quality which is already in use worldwide

### Technical specifications

Further information about general technical data and the design and construction of the N-compact motor series can be found in Catalog M 11 (Order No. E86060-K1711-A101-A3-7600) and in the electronic Catalog CA 01 on CD-ROM (Order No. E86060-D4001-A110-C3-7600).

### Selection and Ordering Data

Type IM B3, degree of protection IP55, temperature class F, utilization in accordance with temperature class B

Rated power kW	Order No. + order codes for further options	Operating values at rated output						Starting torque with direct starting torque	Starting current as multiple of rated current	Stalling torque	Torque class CL	Moment of inertia J kgm <sup>2</sup>
		Rated speed rpm	Efficiency $\eta$		Power factor $\cos \varphi$	Rated current at 400 V A	Rated torque Nm					
			4/4 load %	3/4 load %								
<b>3AC 400 V, 50 Hz</b>												
<b>1500 rpm, 4-pole</b>												
250	1LA8315-4AB 0-Z + B20	1488	96.0	96.0	0.88	425	1600	1.9	6.5	2.8	13	3.6
315	1LA8317-4AB 0-Z + B20	1488	96.3	96.3	0.88	540	2020	2.0	6.8	2.8	13	4.4
355	1LA8353-4AB 0-Z + B20	1488	96.3	96.3	0.87	610	2280	2.1	6.5	2.6	13	6.1
400	1LA8355-4AB 0-Z + B20	1488	96.4	96.4	0.87	690	2570	2.1	6.5	2.6	13	6.8
500	1LA8357-4AB 0-Z + B20	1488	96.8	96.8	0.88	850	3210	2.1	6.5	2.4	13	8.5
<b>Voltage distinctive number:</b> 400 V $\Delta$ /690 VY — 6 500 V $\Delta$ — 5												

Ordering example:

Low-voltage motor  
N-compact Standardline basic version  
400 V $\Delta$ , 50 Hz, 1500 rpm, 4-pole, 355 kW  
with option K45: Anti-condensation heating for 230 V

**1LA8353-4AB60-Z  
+B20+K45**

# Low-Voltage Motors N-compact Standardline

## Operation on supply system

### Options

Option description	Order code	Comment
Standardline design	<b>B20</b>	Always state
Motor temperature sensing by KTY 84-130 temperature sensor	<b>A23</b>	
Motor temperature sensing by 6 PT100 resistance thermometers	<b>A61</b>	
2 screw-in PT100 resistance thermometers in basic circuit for rolling-contact bearings	<b>A72</b>	
Terminal box on RHS (view onto DE)	<b>K09</b>	Standard
Terminal box on LHS (view onto DE)	<b>K10</b>	
Anti-condensation heating for 230 V	<b>K45</b>	
Auxiliary terminal box 1XB3 020	<b>L97</b>	
Auxiliary terminal box 1XB9 013	<b>L98</b>	
Next larger terminal box 1XB1 621	<b>M58</b>	The next larger size of terminal box is recommended when cables with cross sections $> 185 \text{ mm}^2$ are installed for motors with shaft height 315.
Standard paint finish in other colors	<b>Y53</b>	Plain text required

### Dimensional drawings

#### Design:

Type IM B3, rolling-contact bearing, degree of protection IP55, cooling method IC 441

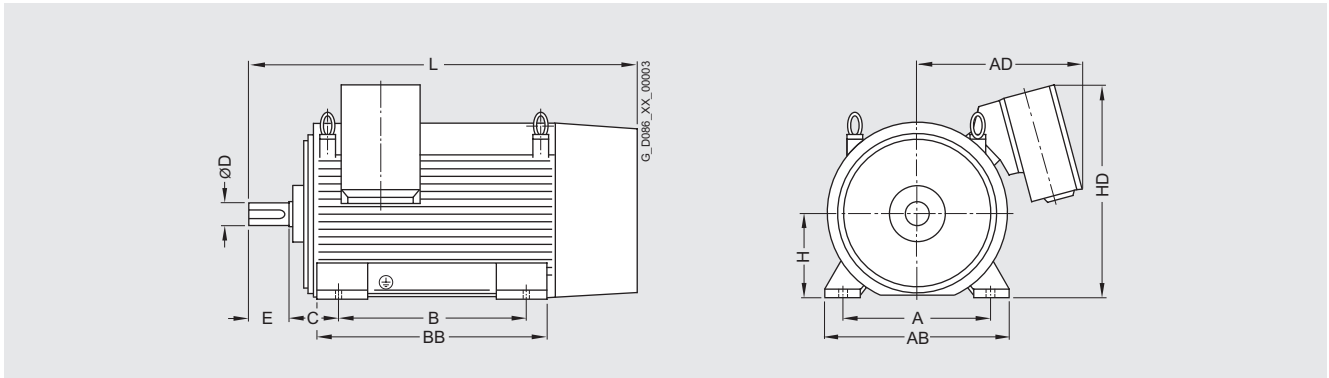

Type	Weight approx. kg	A mm	AB mm	AD mm	B mm	BB mm	C mm	H mm	HD mm	L mm	D mm	E mm
<b>4-pole</b>												
<b>1LA8315-4AB.0</b>	1300	560	680	570	630	780	180	315	825	1410	85	170
<b>1LA8317-4AB.0</b>	1500	560	680	570	630	780	180	315	825	1410	85	170
<b>1LA8353-4AB.0</b>	1900	630	780	710	800	980	200	355	905	1635	95	170
<b>1LA8355-4AB.0</b>	2000	630	780	710	800	980	200	355	905	1635	95	170
<b>1LA8357-4AB.0</b>	2200	630	780	840	800	980	200	355	945	1635	95	170

For further information see Catalog M 11  
(Order No. E86060-K1711-A101-A3-7600).



# Low-Voltage Motors N-compact Standardline

## Operation on supply system

### More information

#### Power cables

As specified in the table below, parallel feeders are required to connect the motors (see also Catalog M 11 "Technical information", "Connection, switching, and terminal boxes"):

Voltage	1LA8 . . .				
	315	317	353	355	357
400 V	•	•	•	•	•
500 V			•	•	

2

# Low-Voltage Motors N-compact **Standardline** Operation with converter

# 3



<b>3/2</b>	<b>Overview</b>
3/2	Variable-speed drive systems for 400 V and 500 V
<b>3/2</b>	<b>Benefits</b>
<b>3/2</b>	<b>Configuration</b>
<b>3/2</b>	<b>Technical specifications</b>
<b>3/3</b>	<b>Selection and Ordering Data</b>
<b>3/3</b>	<b>Options</b>
3/3	N-compact Standardline motor
3/3	Relevant options with SINAMICS G150
3/4	Further converter options
<b>3/5</b>	<b>Dimensional drawings</b>
<b>3/9</b>	<b>More information</b>
3/9	Power cables



# Low-Voltage Motors N-compact Standardline

## Operation with converter

### Overview

Variable-speed drive systems for 400 V and 500 V

**N-compact Standardline motors with SINAMICS G150 frequency converter**



SINAMICS G150 converter cabinet units are designed for use in variable-speed drives in machine construction and plant engineering. They offer a low-cost drive solution which can be flexibly tailored from a wide spectrum of components and options to meet the requirements of individual customers.

A detailed description of the SINAMICS G150 converter series can be found in Catalog D 11 (Order No. E86060-K5511-A101-A2-7600), Part 3.

N-compact Standardline 1LA8 low-voltage motors and SINAMICS G150 frequency converters combine to make an ideally coordinated system for variable-speed drives specially tailored for operating pumps, fans and compressors (square-law characteristic):

- Power range 250 to 500 kW
- Supply voltages 400 V and 500 V, 50 Hz
- 4-pole motor
- Motor type IM B3

### Benefits

Benefits to the customer:

- The complete system can be delivered within 4 weeks.
- Optimally coordinated drive system
- Economical drive solution
- Easy to customize

### Configuration

With the motor - converter combination (selection and ordering data), the drive can be operated under both "low overload" and "high overload" on the basis of the motor drive power (for exceptions, see selection and ordering data, footnotes 4 to 6).

Note about "Low/high overload":

The rated output current of the converter equals the maximum permissible current for continuous operation (without overload).

If the converter must be capable of handling overload conditions such as breakaway torques or shock loads, a base load current determined according to the duty cycle must be applied to calculate the converter rating.

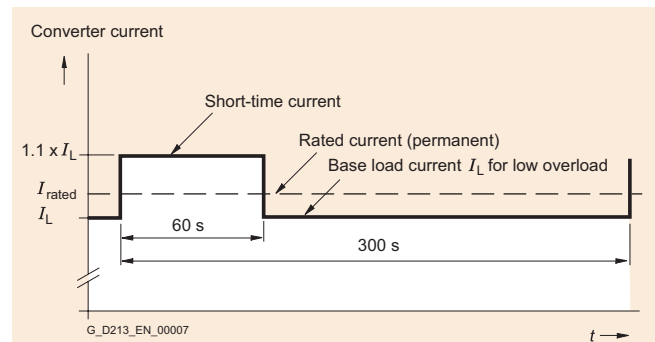

Low overload

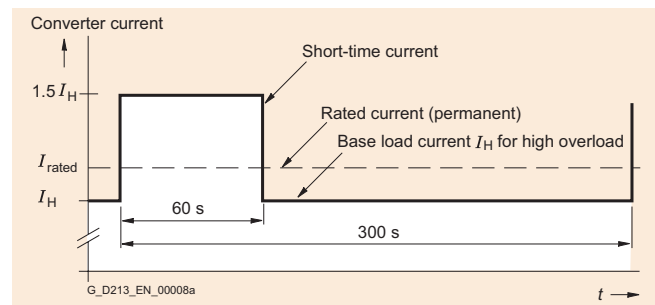

High overload

The diagrams show the duty cycles for two different conditions, i.e. "low overload" and "high overload", with the resulting base load currents  $I_L$  and  $I_H$ .

"Low overload" is defined as a 300 s duty cycle in which the converter may operate at 110% of the base load current  $I_L$  for 60 s, or at 150% for 10 s (not illustrated).

"High overload" is defined as a 300 s duty cycle in which the converter may operate at 150% of the base load current  $I_H$  for 60 s, or at 160% for 10 s (not illustrated).

The converter may be operated under the appropriate overload conditions only if the base load current is not exceeded within the duty cycle either before or after the overload phase.

### Technical specifications

Further information about general technical data and the design of the SINAMICS G150 converter series can be found in Catalog D 11 (Order No. E86060-K5511-A101-A2-7600) and in the electronic Catalog CA 01 on CD-ROM (Order No. E86060-D4001-A110-C3-7600).

### Selection and Ordering Data

The following drive systems (motor + converter) are recommended for applications with square-law load torque.

Drive power <sup>1)</sup> kW	N-compact motor		SINAMICS G150 converter variant A <sup>2)</sup>	
	Order No. + order codes for further options	Rated current A	Order No. for converter options Order No. with -Z + Order codes	Rated output current A
<b>3AC 400 V, 50 Hz</b>				
<b>1500 rpm, 4-pole</b>				
250	1LA8315-4PB80-Z + B20	425	6SL3710-1GE35-0AA0	490
315	1LA8317-4PB80-Z + B20	540	6SL3710-1GE36-1AA0	605
355	1LA8353-4PB80-Z + B20	610	6SL3710-1GE37-5AA0	745
400	1LA8355-4PB80-Z + B20	690	6SL3710-1GE37-5AA0 <sup>3)</sup>	745
500	1LA8357-4PB80-Z + B20	850	6SL3710-1GE41-0AA0	985
<b>3AC 500 V, 50 Hz</b>				
<b>1500 rpm, 4-pole</b>				
250	1LA8315-4PB50-Z + B20	340	6SL3710-1GF34-1AA0	410
315	1LA8317-4PB50-Z + B20	432	6SL3710-1GF34-7AA0 <sup>4)</sup>	465
355	1LA8353-4PB50-Z + B20	488	6SL3710-1GF35-8AA0	575
400	1LA8355-4PB50-Z + B20	552	6SL3710-1GF35-4AA0	735
500	1LA8357-4PB50-Z + B20	680	6SL3710-1GF37-4AA0 <sup>5)</sup>	735

- Temperature class F, utilization in accordance with F. The drive output must be reduced by 10% for motors utilized in accordance with temperature class B.
- For information about SINAMICS G150 design variant A and "overload capability", refer to Catalog D 11, Part 3 and section "Configuration".
- Converter model 6SL3710-1GE38-4AA0 (840 A) must be selected when this drive is operated under high overload conditions!
- Converter model 6SL3710-1GF35-8AA0 (575 A) must be selected when this drive is operated under high overload conditions!
- Converter model 6SL3710-1GF38-1AA0 (810 A) must be selected when this drive is operated under high overload conditions!

#### Ordering example:

Low-voltage motor  
N-compact Standardline basic version  
3AC 400 V, 50 Hz, 1500 rpm, 4-pole, 355 kW  
with motor option K45: Anti-condensation heating for 230 V

Matching converter  
SINAMICS G150 variant A  
with converter option K50: Sensor Module Cabinet-Mounted for motor speed acquisition

**1LA8353-4PB80-Z  
+B20+K45  
6SL3710-1GE37-5AA0-Z  
+K50**

### Options

N-compact Standardline motor		Relevant option with SINAMICS G150	
Option description	Order code	Option description	Order code
Motor temperature sensing using built-in temperature sensor KTY 84-130	A23	Standard	-
Motor temperature sensing by means of 6 built-in PT100 G resistance thermometers	A61	PT100 evaluation unit for 6 sensors, divided into two groups with factory setting, e.g. with motors, 3 PT100 for the stator windings and two for the motor bearings	L86
Installation of 2 screw-in PT100 resistance thermometers in basic circuit for rolling-contact bearings	A72		
Built-on pulse encoder LL861 900 220	H70	Sensor Module Cabinet-Mounted for motor speed acquisition	K50
Built-on pulse encoder HOG 10 D 1024 I	H73		
Terminal box on RHS (view onto DE)	K09		
Terminal box on LHS (view onto DE)	K10		
Anti-condensation heating for 230 V	K45		
Auxiliary terminal box 1XB3 020	L97		
Auxiliary terminal box 1XB9 013	L98		
Next larger terminal box 1XB1 621 (the next larger size of terminal box is recommended when cables with cross sections >185 mm <sup>2</sup> are installed for motors with shaft height 315)	M58		
Standard paint finish in other colors (plain text required)	Y53		

# Low-Voltage Motors N-compact Standardline

## Operation with converter

Further converter options  
(see Catalog D 11 for detailed descriptions):

Option description	Order code
<b>Input side</b>	
Line filter for use in the first environment to EN 61 800-3, category C2 (TN/TT supplies)	L00
Main contactor for currents < 800 A	L13
Without line reactor in power range P < 500 kW	L22
Line reactor 2% may be required for P > 500 kW	L23
EMC shield bus <sup>1)</sup> (cable connection from below)	M70
PE bus <sup>1)</sup> (cable connection from below)	M75
<b>Output side</b>	
EMC shield bus <sup>1)</sup> (cable connection from below)	M70
PE bus <sup>1)</sup> (cable connection from below)	M75
<b>Motor protection and safety functions</b>	
EMERGENCY STOP button in the cabinet door	L45
EMERGENCY STOP category 0, 230 V AC or 24 V DC, uncontrolled stop	L57
EMERGENCY STOP category 1, 230 V AC, controlled stop <sup>2)</sup>	L59
EMERGENCY STOP category 1, 24 V DC, controlled stop <sup>2)</sup>	L60
Thermistor protection unit with PTB approval (alarm)	L83
Thermistor protection unit with PTB approval (switch-off)	L84
Insulation monitoring	L87
Additional shock protection	M60
<b>Increase in degree of protection</b>	
IP21 degree of protection	M21
IP23 degree of protection	M23
IP54 degree of protection	M54
<b>Mechanical options</b>	
Plinth, 100 mm high, RAL 7022	M06
Cable connection area, 200 mm high, RAL 7035	M07
Power supply connection from above	M13
Motor connection from above	M78
Top-mounted crane transport assembly for cabinets	M90
<b>Miscellaneous options</b>	
Customer terminal block extension	G61
Cabinet illumination with service socket	L50
Anti-condensation heating for cabinet	L55
200 kW braking unit	L62
<b>Languages</b>	
Documentation in English/French	D58
Documentation in English/Spanish	D60
Documentation in English/Italian	D80
Rating plate and operator panel in English/French	T58
Rating plate and operator panel in English/Spanish	T60
Rating plate and operator panel in English/Italian	T80
<b>Options specific to chemical industry</b>	
NAMUR terminal block	B00
Protective separation for 24 V supply (PELV)	B02
Separate output for external auxiliaries (uncontrolled)	B03

- 1) These options are listed for the input and output options, but are only required once.
- 2) The drive stop requirements must be taken into account with this option. Additional braking units may be needed.



### Dimensional drawings

#### SINAMICS G150 Converter Cabinet Units - Variant A

#### 6SL3710-1GE35-0AA0

Mains supply and motor terminals at bottom of cabinet (see Catalog D 11 for further connection options)

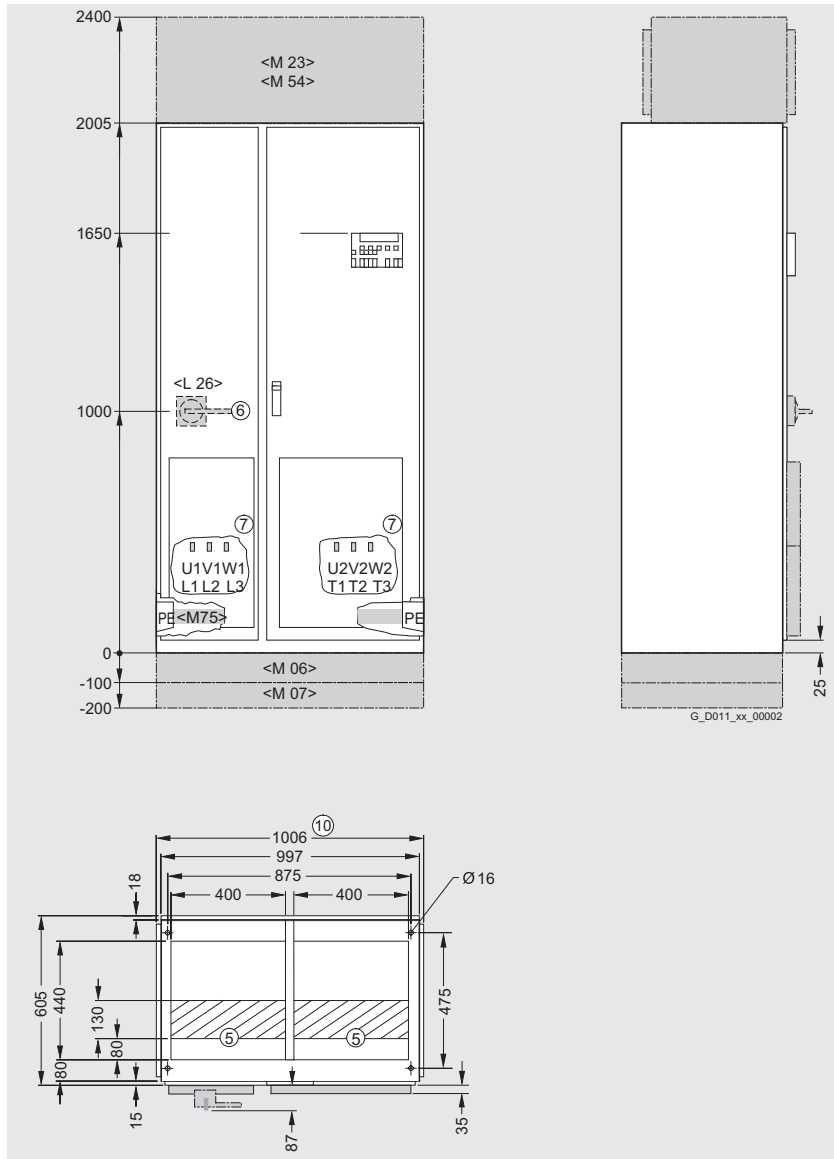

- ① Minimum ceiling height for wall mounting
  - ② Ventilation grille
  - ③ Air outlet zone
  - ④ Air inlet zone
  - ⑤ Cables can enter from below within hatched area
  - ⑥ Main switch, can be secured by padlock
  - ⑦ Power connection
  - ⑧ Degrees of protection option
  - ⑨ Degrees of protection IP20  
IP21 option <M21>  
IP23 option <M23>  
IP54 option <M54>
  - ⑩ Transport unit
- Options are shaded grey

### Degrees of protection

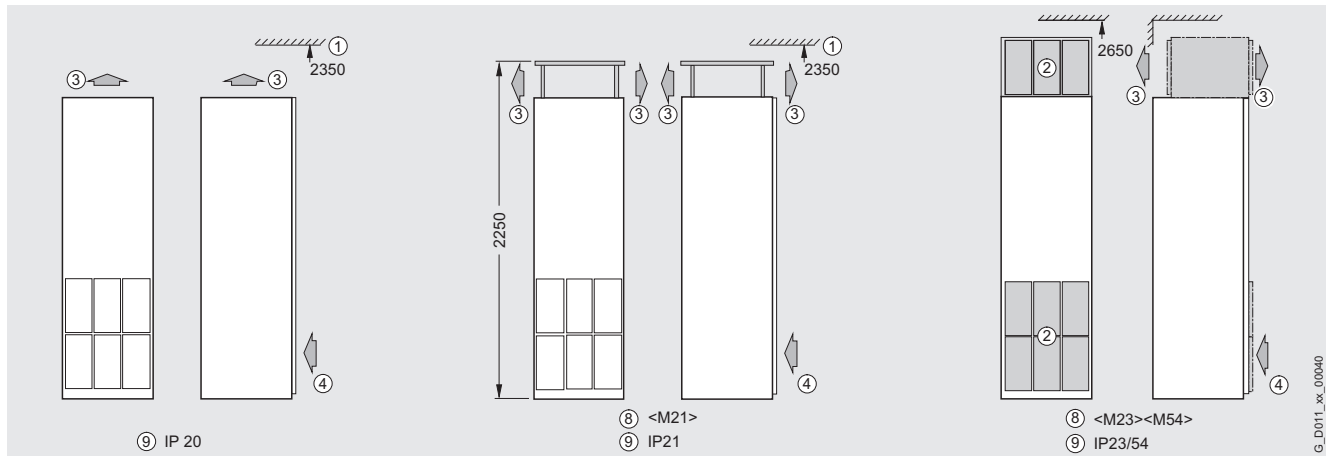

# Low-Voltage Motors N-compact Standardline

## Operation with converter

### Dimensional drawings

6SL3710-1GE36-1AA0, 6SL3710-1GF34-1AA0,  
6SL3710-1GF34-7AA0, 6SL3710-1GF35-8AA0

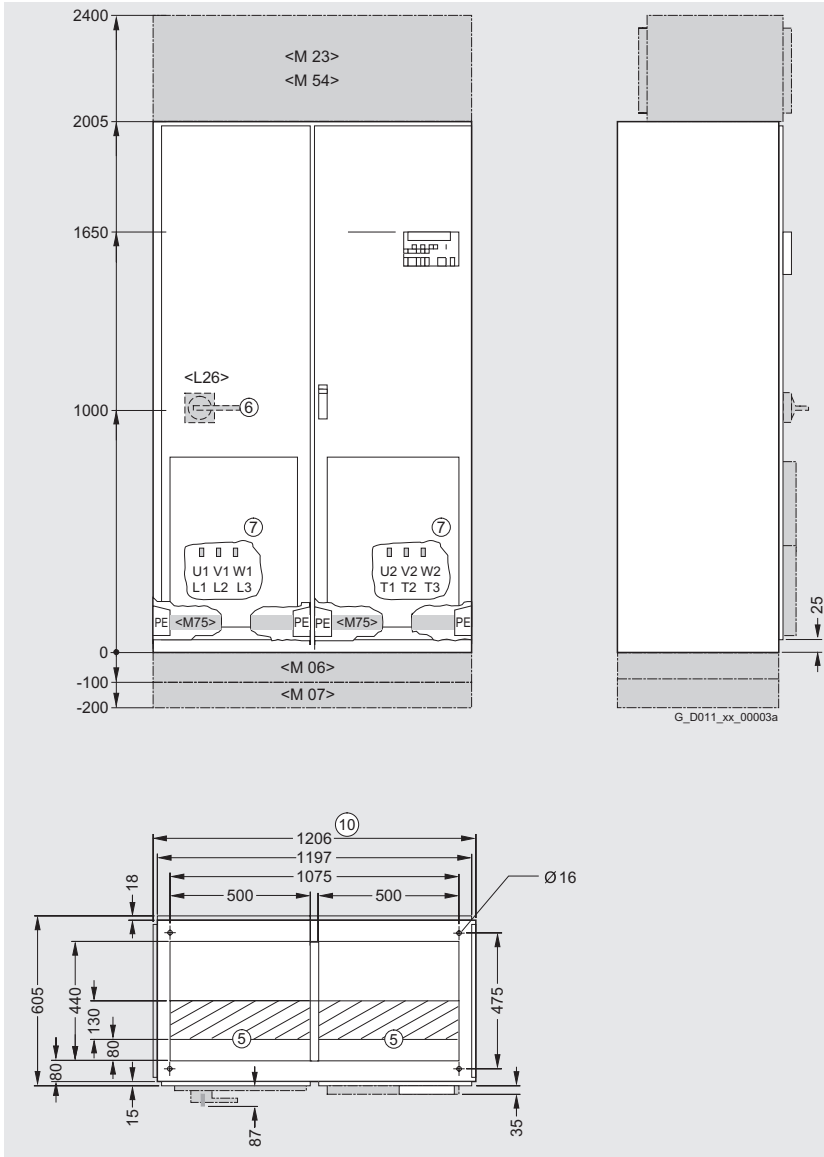

- ① Minimum ceiling height for wall mounting
- ② Ventilation grille
- ③ Air outlet zone
- ④ Air inlet zone
- ⑤ Cables can enter from below within hatched area
- ⑥ Main switch, can be secured by padlock
- ⑦ Power connection
- ⑧ Degrees of protection option  
IP20  
IP21 option <M21>  
IP23 option <M23>  
IP54 option <M54>

⑩ Transport unit  
Options are shaded grey

3

### Degrees of protection

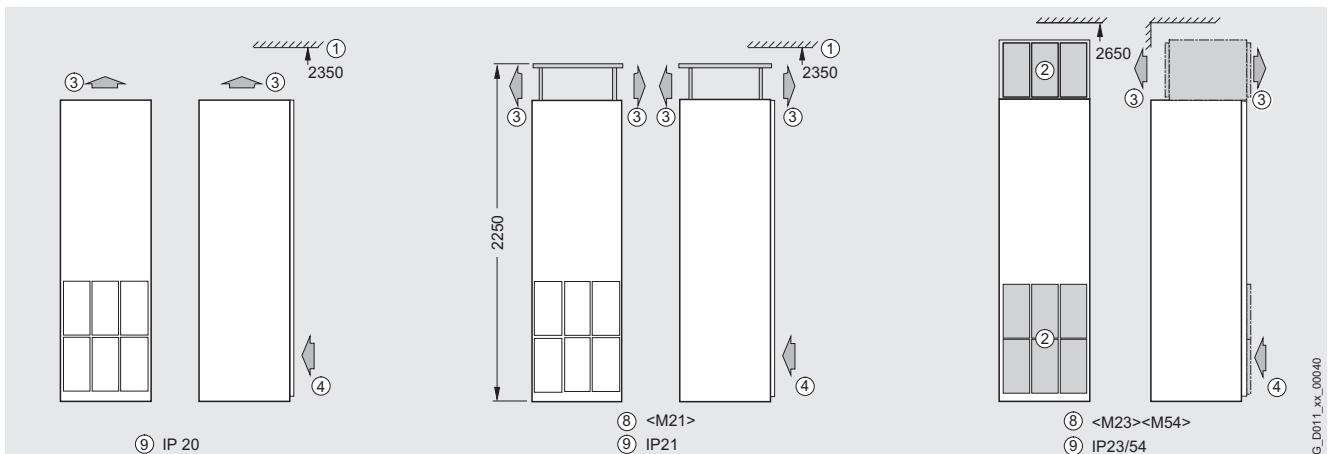

G\_D011\_xx\_00040

### Dimensional drawings

6SL3710-1GE37-5AA0, 6SL3710-1GE38-4AA0

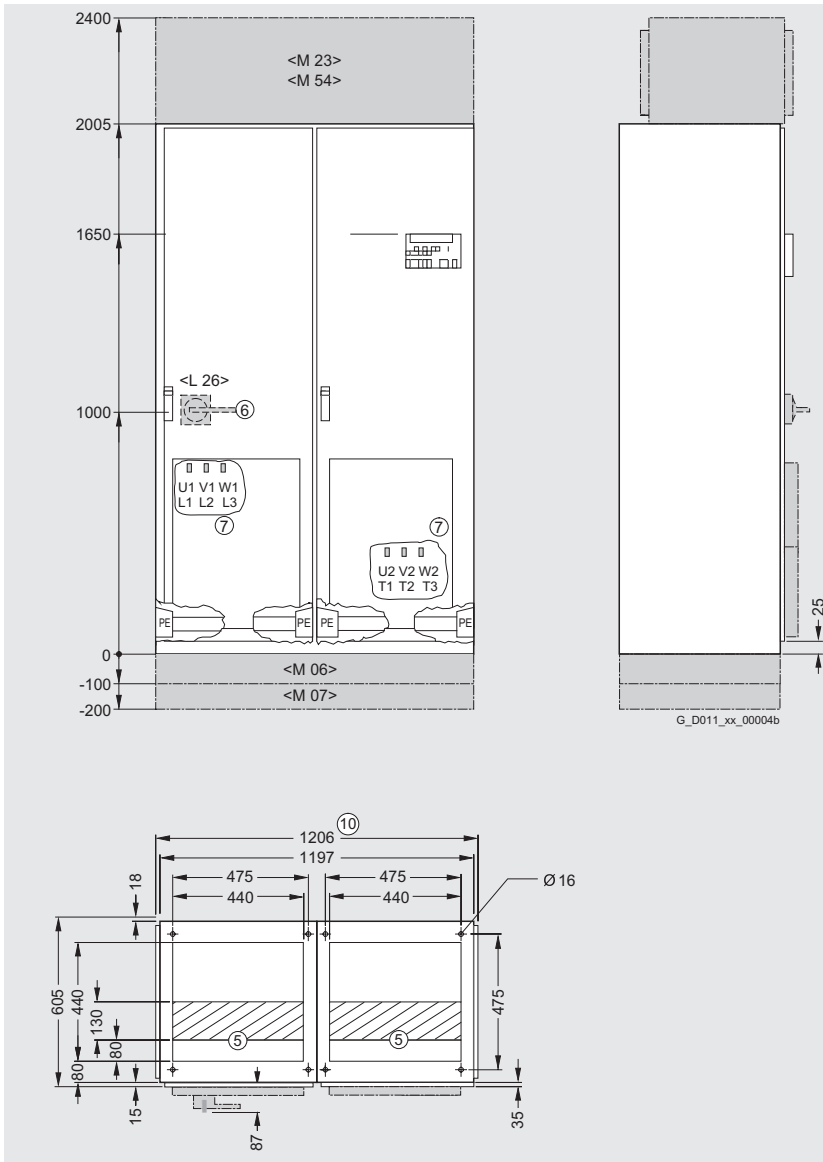

- ① Minimum ceiling height for wall mounting
  - ② Ventilation grille
  - ③ Air outlet zone
  - ④ Air inlet zone
  - ⑤ Cables can enter from below within hatched area
  - ⑥ Main switch, can be secured by padlock
  - ⑦ Power connection
  - ⑧ Degrees of protection option
  - ⑨ Degrees of protection IP20  
IP21 option <M21>  
IP23 option <M23>  
IP54 option <M54>
  - ⑩ Transport unit
- Options are shaded grey

3

### Degrees of protection

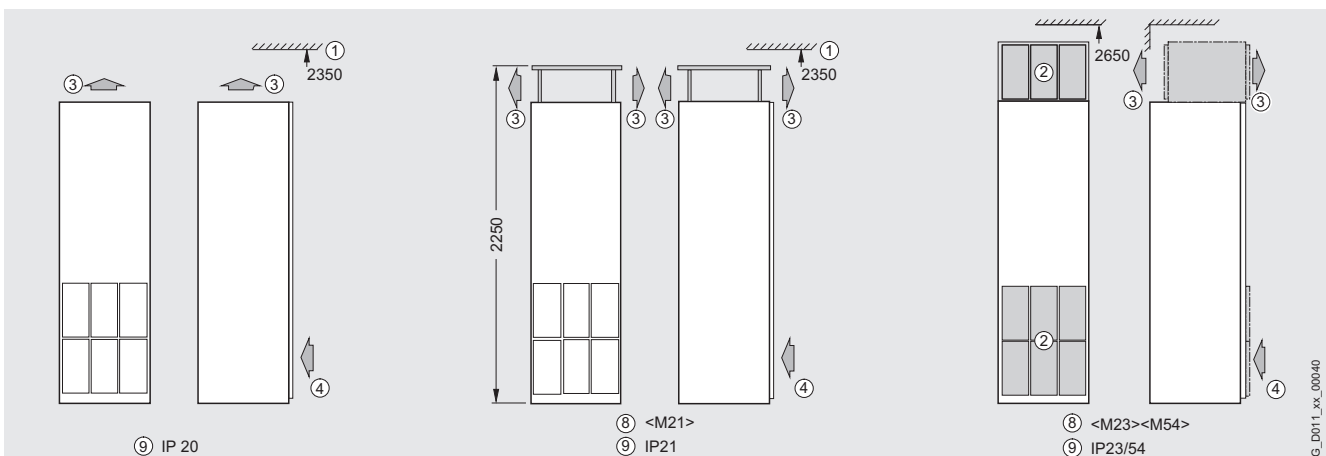

# Low-Voltage Motors N-compact Standardline

## Operation with converter

### Dimensional drawings

6SL3710-1GE41-0AA0, 6SL3710-1GF37-4AA0,  
6SL3710-1GF38-1AA0

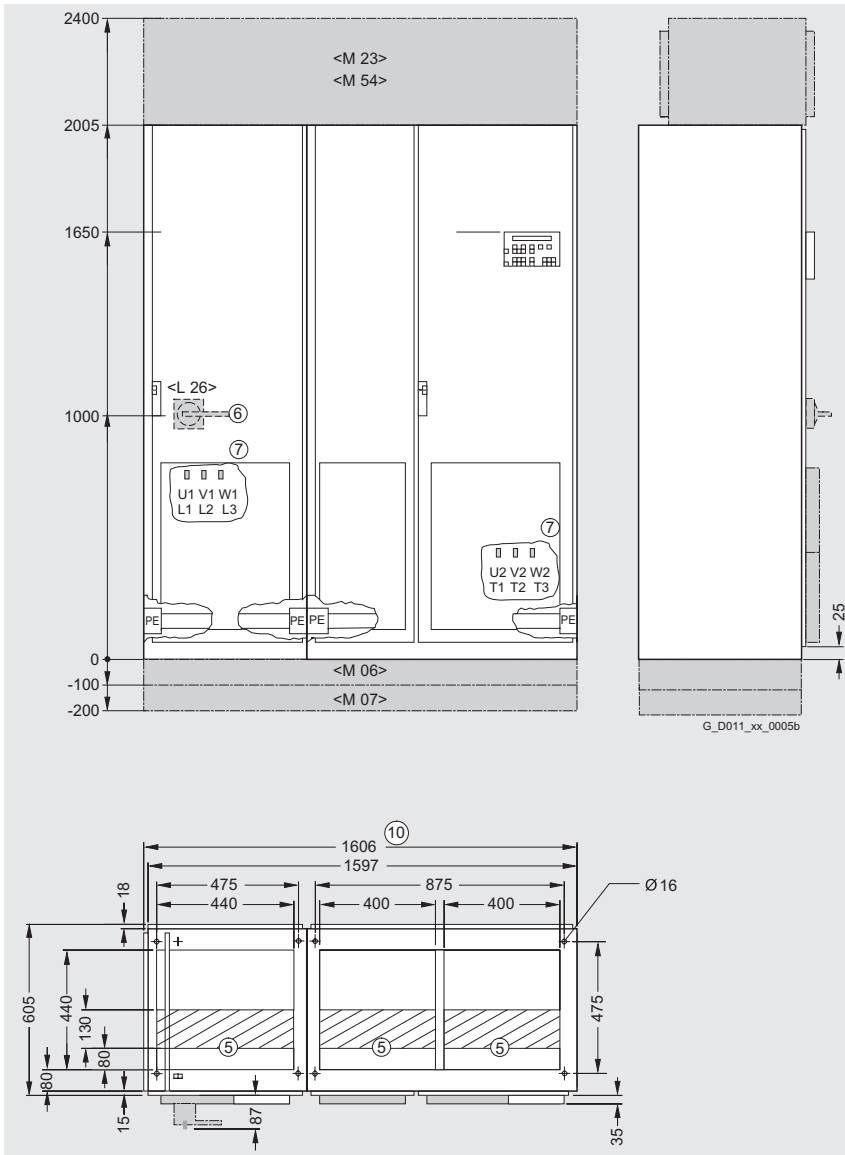

- ① Minimum ceiling height for wall mounting
  - ② Ventilation grille
  - ③ Air outlet zone
  - ④ Air inlet zone
  - ⑤ Cables can enter from below within hatched area
  - ⑥ Main switch, can be secured by padlock
  - ⑦ Power connection
  - ⑧ Degrees of protection option  
IP20  
IP21 option <M21>  
IP23 option <M23>  
IP54 option <M54>
  - ⑩ Transport unit
- Options are shaded grey

3

### Degrees of protection

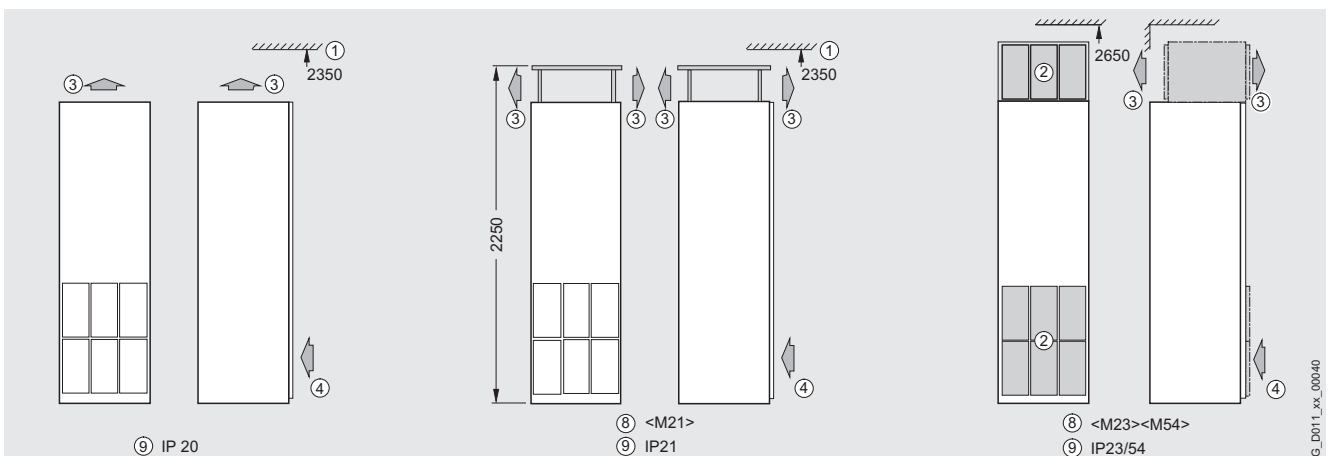

### More information

#### Power cables

The following table shows the recommended or maximum possible cable connections on the power supply and motor sides.

Drive power kW	Power supply connection (converter input)				Motor connection (converter output)				Motor terminal box		
	Cable cross section (to DIN VDE)				Cable cross section (to DIN VDE)				Number of terminals	Contact screw thread	Max. diameter (sealing area terminal box)
	Recommended	Max. cross section	Fixing screw M12 (no. of holes)		Recommended	Max. cross section	Fixing screw M12 (no. of holes)				
	400 V mm <sup>2</sup>	500 V mm <sup>2</sup>	mm <sup>2</sup>		400 V mm <sup>2</sup>	500 V mm <sup>2</sup>	mm <sup>2</sup>				mm
250	2 x 120	2 x 95	4 x 240	(2)	2 x 120	2 x 95	2 x 240	(2)	6	M12	40 ... 48
315	2 x 185	2 x 120	4 x 240	(2)	2 x 185	2 x 120	2 x 240	(2)	6	M12	40 ... 48
355	2 x 240	2 x 150	4 x 240	(2)	2 x 240	2 x 150	4 x 240	(2)	6	M16	41 ... 56
400	2 x 240	2 x 185	4 x 240	(2)	2 x 240	2 x 185	4 x 240	(2)	6	M16	41 ... 56
500	3 x 185	2 x 240	8 x 240	(4)	3 x 185	2 x 240	6 x 240	(3)	12	M16	40 ... 75 <sup>1)</sup>

1) two-section plate.

The cross section recommendations are based on the fuses specified in Part 3 "Accessories" of Catalog D11, and on single routing of 3-core copper cables at 40 °C ambient temperature.

If these conditions do not apply (cable routing, number of cables and ambient temperature), the planning guide for cable installation in Part 4 "Conductor cross sections and terminals" in Catalog D11 must be observed.



# Low-Voltage Motors N-compact Standardline

Notes

3

# High-Voltage Motors H-compact **Standardline** Operation on supply system

# 4



<b>4/2</b>	<b>Overview</b>
<b>4/2</b>	<b>Benefits</b>
<b>4/2</b>	<b>Technical specifications</b>
<b>4/3</b>	<b>Selection and Ordering Data</b>
<b>4/7</b>	<b>Options</b>
<b>4/8</b>	<b>Dimensional drawings</b>
<b>4/9</b>	<b>More information</b>
4/9	Description - construction details
4/9	Housing, cooling system
4/9	Hoisting gear
4/9	Rotor construction
4/9	Shaft
4/9	Direction of rotation, fans and fan shroud
4/9	Vibration response
4/9	Insulation system
4/9	Noise
4/9	Switching frequency
4/10	Terminal box
4/10	Auxiliary terminal box
4/10	Paint finish
4/10	Bearing construction



# High-Voltage Motors H-compact Standardline

## Operation on supply system

### Overview

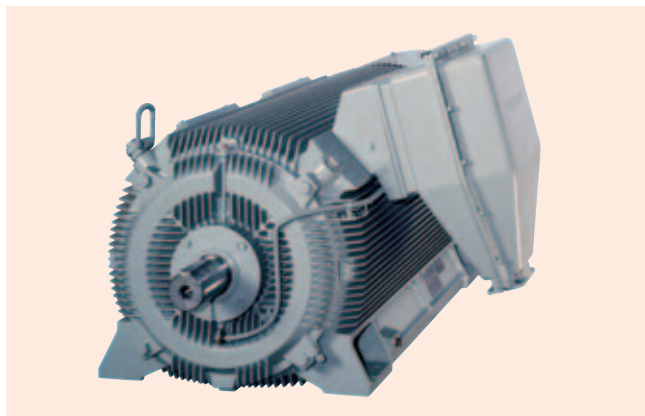

H-compact Standardline is a range of standardized, rib-cooled high-voltage motors incorporating the latest state-of-the-art technology.

Their appeal lies in their excellent reliability, durability and robust design.

The following versions of H-compact Standardline motors are available:

- Power range 200 to 800 kW
- Supply voltages 3 / 3.3 / 6 and 6.6 kV, 50 Hz
- 2-pole, 4-pole and 6-pole
- Type of construction IM B3

### Benefits

The focus on a design which is standardized, but capable of satisfying a wide range of applications, has made it possible to optimize production processes and consequently slash delivery times and the price at which high-voltage motors are supplied.

Benefits to the customer:

- State-of-the-art motor technology which is already in use worldwide
- Attractive price
- Quick delivery time of only 6 weeks
- Maximum power density
- Low operating costs thanks to excellent efficiency
- High output combined with small dimensions makes it possible to build extremely compact units

### Technical specifications

Type of construction	IM B3 (IM 1001)
Shaft heights	315 mm, 355 mm, 400 mm
Type of protection	IP55
Cooling method	IC 411; ribbed cooling, self-ventilated, with additional inner cooling circuit
Ambient conditions	Max. ambient temperature (cooling medium temp.) CT = 40 °C Installation altitude ≤1000 m above sea level. Ambient temperatures up to 55 °C possible with utilization according to temperature class F. Operation and starting permissible at temperatures down to -20 °C.
Insulation system	MICALASTIC® with Vacuum Pressure Impregnation (VPI)
Rotor construction	with aluminum die-cast cage
Bearing construction	Deep-groove ball bearing to DIN 625, with SPM nipple (shock pulse measurement)
Bearing box and shields	Made of grey cast iron, integrally cast motor feet
Temperature monitoring	By 6 PT 100s in stator winding as standard (not included if PTC thermistors are ordered)
Auxiliary terminal box	standard feature
Regulations and standards	in accordance with IEC 60034-1 ff.

### Selection and Ordering Data

Note:

Motors are available only with the specified data for voltage, frequency and output.

The documentation supplied is standardized. It contains starting characteristics for  $V_{rated}$  and 80 %  $V_{rated}$  without load torque. A starting inspection is not included.

Rated output 1)	Order No. + order codes for further options	Operating values at rated output						Starting torque	Starting current	Stalling torque	Moment of inertia J		Sound pressure level 2)
		Rated speed	Efficiency $\eta$ with		Power factor	Rated current	Rated torque				with direct starting as multiple of rated torque		
kW		rpm	4/4 load %	3/4 load %	cos $\varphi$	A	Nm	torque	current	torque	kgm <sup>2</sup>	kgm <sup>2</sup>	dB(A)
<b>3 kV, 50 Hz</b>													
<b>3000 rpm, 2-pole</b>													
200	1LA4310-2AN30-Z + B20	2970	95.2	95.2	0.87	46.0	643	0.90	5.05	2.3	2.2	28	73/74
236	1LA4312-2AN30-Z + B20	2967	95.0	95.2	0.87	55.0	759	0.90	5.00	2.3	2.2	26	73/74
300	1LA4314-2AN30-Z + B20	2972	95.7	95.8	0.88	69.0	964	1.05	5.20	2.4	2.7	30	73/74
355	1LA4316-2AN30-Z + B20	2974	96.2	96.2	0.88	81.0	1140	1.10	5.30	2.5	3.1	35	73/74
400	1LA4350-2AN30-Z + B20	2978	96.1	96.2	0.88	91.0	1283	1.05	5.25	2.3	4.3	38	75/76
450	1LA4352-2AN30-Z + B20	2978	96.4	96.4	0.88	102.0	1443	1.20	5.55	2.5	4.8	43	75/76
500	1LA4354-2AN30-Z + B20	2980	96.6	96.7	0.88	114.0	1602	1.20	5.55	2.5	5.2	46	75/76
560	1LA4400-2AN30-Z + B20	2984	96.5	96.4	0.88	128.0	1792	0.85	5.40	2.5	7.8	26	77/78
650	1LA4402-2AN30-Z + B20	2985	96.8	96.7	0.88	146.0	2079	0.90	5.60	2.6	8.7	27	77/78
750	1LA4404-2AN30-Z + B20	2985	96.7	96.7	0.89	168.5	2398	0.95	5.60	2.6	9.9	30	77/78
<b>1500 rpm, 4-pole</b>													
200	1LA4310-4AN30-Z + B20	1480	94.3	94.4	0.81	50.0	1290	1.15	5.20	2.30	2.8	159	75/77
250	1LA4312-4AN30-Z + B20	1480	95.0	95.2	0.84	60.0	1613	1.15	5.30	2.30	3.5	201	75/77
300	1LA4314-4AN30-Z + B20	1480	95.2	95.4	0.85	72.0	1936	1.25	5.50	2.40	4.0	222	75/77
365	1LA4316-4AN30-Z + B20	1481	95.7	95.9	0.85	87.0	2353	1.25	5.50	2.40	4.8	297	75/77
400	1LA4350-4AN30-Z + B20	1485	95.7	95.8	0.84	96.0	2572	1.25	5.50	2.50	6.0	224	77/79
470	1LA4352-4AN30-Z + B20	1484	95.9	96.0	0.85	110.0	3024	1.20	5.30	2.35	6.9	247	77/79
560	1LA4354-4AN30-Z + B20	1485	96.2	96.3	0.86	130.0	3601	1.30	5.50	2.40	8.1	296	77/79
630	1LA4400-4AN30-Z + B20	1488	96.3	96.3	0.85	148.0	4043	1.20	5.50	2.50	11.6	288	79/81
710	1LA4402-4AN30-Z + B20	1488	96.5	96.5	0.85	166.0	4556	1.20	5.50	2.50	12.9	330	79/81
800	1LA4404-4AN30-Z + B20	1488	96.6	96.6	0.86	186.0	5134	1.20	5.50	2.50	14.5	381	79/81
<b>1000 rpm, 6-pole</b>													
236	1LA4314-6AN30-Z + B20	986	94.6	94.9	0.82	59.0	2286	1.25	5.30	2.50	5.3	375	69/72
270	1LA4316-6AN30-Z + B20	985	94.8	95.2	0.82	66.0	2617	1.25	5.50	2.40	6.4	431	69/72
315	1LA4350-6AN30-Z + B20	989	95.3	95.5	0.82	78.0	3042	1.10	5.30	2.30	10.8	541	71/74
365	1LA4352-6AN30-Z + B20	989	95.6	95.8	0.83	89.0	3523	1.10	5.30	2.20	12.7	667	71/74
425	1LA4354-6AN30-Z + B20	990	95.8	95.9	0.82	104.0	4099	1.25	5.50	2.40	15.0	841	71/74
490	1LA4400-6AN30-Z + B20	991	95.9	96.0	0.81	118.0	4722	1.05	5.50	2.30	21.2	740	73/76
570	1LA4402-6AN30-Z + B20	992	96.2	96.3	0.81	136.0	5487	1.10	5.50	2.30	24.2	1193	73/76
630	1LA4404-6AN30-Z + B20	991	96.3	96.3	0.80	154.0	6071	1.20	5.50	2.40	27.3	1233	73/76

1) Temperature class F, utilization in accordance with B.

2) Measured at distance of 1 m in accordance with DIN 45635 (Part 1), tolerance +3 dB(A).

# High-Voltage Motors H-compact Standardline

## Operation on supply system

Rated output 1)	Order No. + order codes for further options	Operating values at rated output						Starting torque	Starting current	Stalling torque	Moment of inertia J		Sound pressure level 2)			
		Rated speed	Efficiency $\eta$ with		Power factor $\cos \varphi$	Rated current	Rated torque				with direct starting as multiple of rated			Motor	External max. perm.	
			4/4 load	3/4 load							torque	current				torque
kW		rpm	%	%	A	Nm							dB(A)			
<b>3.3 kV, 50 Hz</b>																
<b>3000 rpm, 2-pole</b>																
200	1LA4310-2AN00-Z + B20	2977	95.5	95.2	0.85	43.0	641	1.10	6.00	2.85	2.2	28	73/74			
236	1LA4312-2AN00-Z + B20	2975	95.2	95.2	0.84	52.0	757	1.10	5.90	2.80	2.2	26	73/74			
300	1LA4314-2AN00-Z + B20	2978	95.9	95.7	0.85	65.0	962	1.30	6.15	2.95	2.7	30	73/74			
355	1LA4316-2AN00-Z + B20	2980	96.3	96.1	0.85	76.0	1138	1.35	6.30	3.10	3.1	35	73/74			
400	1LA4350-2AN00-Z + B20	2983	96.3	96.2	0.85	86.0	1280	1.30	6.15	2.85	4.3	38	75/76			
450	1LA4352-2AN00-Z + B20	2983	96.5	96.4	0.85	96.5	1441	1.45	6.50	3.10	4.8	43	75/76			
500	1LA4354-2AN00-Z + B20	2985	96.7	96.7	0.85	107.0	1600	1.45	6.55	3.10	5.2	46	75/76			
560	1LA4400-2AN00-Z + B20	2988	96.6	96.3	0.84	121.5	1790	1.05	6.35	3.05	7.8	26	77/78			
650	1LA4402-2AN00-Z + B20	2988	96.8	96.6	0.85	138.0	2077	1.10	6.60	3.20	8.7	27	77/78			
750	1LA4404-2AN00-Z + B20	2989	96.8	96.6	0.87	157.0	2396	1.15	6.70	3.20	9.9	30	77/78			
<b>1500 rpm, 4-pole</b>																
200	1LA4310-4AN00-Z + B20	1484	94.4	94.2	0.74	50.0	1287	1.40	5.75	2.80	2.8	159	75/77			
250	1LA4312-4AN00-Z + B20	1485	95.2	95.2	0.79	58.0	1608	1.40	6.15	2.85	3.5	201	75/77			
300	1LA4314-4AN00-Z + B20	1484	95.4	95.4	0.80	69.5	1931	1.55	6.35	2.95	4.0	222	75/77			
365	1LA4316-4AN00-Z + B20	1485	95.9	95.9	0.80	83.5	2346	1.55	6.35	2.95	4.8	297	75/77			
400	1LA4350-4AN00-Z + B20	1488	95.8	95.6	0.77	95.0	2566	1.55	6.20	3.05	6.0	224	77/79			
470	1LA4352-4AN00-Z + B20	1488	96.1	96.0	0.80	105.5	3017	1.45	6.15	2.85	6.9	247	77/79			
560	1LA4354-4AN00-Z + B20	1489	96.4	96.3	0.82	124.0	3592	1.60	6.40	2.95	8.1	296	77/79			
630	1LA4400-4AN00-Z + B20	1491	96.4	96.2	0.80	143.0	4036	1.45	6.35	3.05	11.6	288	79/81			
710	1LA4402-4AN00-Z + B20	1491	96.6	96.4	0.81	159.0	4548	1.45	6.40	3.05	12.9	330	79/81			
800	1LA4404-4AN00-Z + B20	1491	96.7	96.5	0.82	177.5	5125	1.45	6.45	3.05	14.5	381	79/81			
<b>1000 rpm, 6-pole</b>																
236	1LA4314-6AN00-Z + B20	989	94.8	94.8	0.77	57.0	2279	1.50	6.10	3.05	5.3	375	69/72			
270	1LA4316-6AN00-Z + B20	988	95.1	95.2	0.78	62.5	2609	1.55	6.45	2.95	6.4	431	69/72			
315	1LA4350-6AN00-Z + B20	991	95.5	95.4	0.78	74.5	3034	1.35	6.20	2.80	10.8	541	71/74			
365	1LA4352-6AN00-Z + B20	991	95.8	95.7	0.79	84.5	3515	1.35	6.20	2.70	12.7	667	71/74			
425	1LA4354-6AN00-Z + B20	992	95.9	95.8	0.78	99.5	4091	1.55	6.40	2.95	15.0	841	71/74			
490	1LA4400-6AN00-Z + B20	993	96.0	95.9	0.81	111.5	4713	1.30	6.50	2.80	21.2	740	73/76			
570	1LA4402-6AN00-Z + B20	994	96.3	96.2	0.81	128.5	5476	1.35	6.45	2.80	24.2	1193	73/76			
630	1LA4404-6AN00-Z + B20	993	96.4	96.2	0.78	146.5	6060	1.45	6.45	2.95	27.3	1233	73/76			

1) Temperature class F, utilization in accordance with B.

2) Measured at distance of 1 m in accordance with DIN 45635 (Part 1), tolerance +3 dB(A).



# High-Voltage Motors H-compact Standardline

## Operation on supply system

Rated output 1)	Order No. + order codes for further options	Operating values at rated output						Starting torque with direct starting as multiple of rated torque	Starting current current	Stalling torque torque	Moment of inertia J		Sound pressure level 2)	
		Rated speed rpm	Efficiency $\eta$ with		Power factor $\cos \varphi$	Rated current A	Rated torque Nm				Motor kgm <sup>2</sup>	External max. perm. kgm <sup>2</sup>		No load/load dB(A)
			4/4 load %	3/4 load %										
<b>6 kV, 50 Hz</b>														
<b>3000 rpm, 2-pole</b>														
200	1LA4310-2AN60-Z + B20	2970	95.2	95.2	0.87	23.0	643	0.90	5.00	2.30	2.2	28	73/74	
236	1LA4312-2AN60-Z + B20	2967	95.0	95.2	0.87	27.5	759	0.90	5.00	2.30	2.2	26	73/74	
300	1LA4314-2AN60-Z + B20	2972	95.7	95.8	0.88	34.5	964	1.05	5.20	2.40	2.7	30	73/74	
355	1LA4316-2AN60-Z + B20	2974	96.2	96.2	0.88	40.5	1140	1.10	5.30	2.50	3.1	35	73/74	
400	1LA4350-2AN60-Z + B20	2978	96.1	96.2	0.88	45.5	1283	1.05	5.20	2.30	4.3	38	75/76	
450	1LA4352-2AN60-Z + B20	2978	96.4	96.4	0.88	51.0	1443	1.20	5.50	2.50	4.8	43	75/76	
500	1LA4354-2AN60-Z + B20	2980	96.6	96.7	0.88	57.0	1602	1.20	5.50	2.50	5.2	46	75/76	
560	1LA4400-2AN60-Z + B20	2984	96.5	96.4	0.88	64.0	1792	0.85	5.40	2.50	7.8	26	77/78	
650	1LA4402-2AN60-Z + B20	2985	96.8	96.7	0.88	73.0	2079	0.90	5.60	2.60	8.7	27	77/78	
750	1LA4404-2AN60-Z + B20	2985	97.0	96.9	0.89	84.0	2399	0.95	5.60	2.60	9.9	30	77/78	
<b>1500 rpm, 4-pole</b>														
200	1LA4310-4AN60-Z + B20	1480	94.3	94.4	0.81	25.0	1290	1.15	5.20	2.30	2.8	159	75/77	
250	1LA4312-4AN60-Z + B20	1480	95.0	95.2	0.84	30.0	1613	1.15	5.30	2.30	3.5	201	75/77	
300	1LA4314-4AN60-Z + B20	1480	95.2	95.4	0.85	36.0	1936	1.25	5.50	2.40	4.0	222	75/77	
365	1LA4316-4AN60-Z + B20	1481	95.7	95.9	0.85	43.5	2353	1.25	5.50	2.40	4.8	297	75/77	
400	1LA4350-4AN60-Z + B20	1485	95.7	95.8	0.84	48.0	2572	1.25	5.50	2.50	6.0	224	77/79	
470	1LA4352-4AN60-Z + B20	1484	95.9	96.0	0.85	55.0	3024	1.20	5.30	2.35	6.9	247	77/79	
560	1LA4354-4AN60-Z + B20	1485	96.2	96.3	0.86	65.0	3601	1.30	5.50	2.40	8.1	296	77/79	
630	1LA4400-4AN60-Z + B20	1488	96.3	96.3	0.85	74.0	4043	1.20	5.50	2.50	11.6	288	79/81	
710	1LA4402-4AN60-Z + B20	1488	96.5	96.5	0.85	83.0	4556	1.20	5.50	2.50	12.9	330	79/81	
800	1LA4404-4AN60-Z + B20	1488	96.6	96.6	0.86	93.0	5134	1.20	5.50	2.50	14.5	381	79/81	
<b>1000 rpm, 6-pole</b>														
236	1LA4314-6AN60-Z + B20	986	94.6	94.9	0.82	29.5	2286	1.25	5.30	2.50	5.3	375	69/72	
270	1LA4316-6AN60-Z + B20	985	94.8	95.2	0.82	33.0	2617	1.25	5.50	2.40	6.4	431	69/72	
315	1LA4350-6AN60-Z + B20	989	95.3	95.5	0.82	39.0	3041	1.10	5.30	2.30	10.8	541	71/74	
365	1LA4352-6AN60-Z + B20	989	95.6	95.8	0.83	44.5	3524	1.10	5.30	2.20	12.7	667	71/74	
425	1LA4354-6AN60-Z + B20	990	95.8	95.9	0.82	52.0	4099	1.25	5.50	2.40	15.0	841	71/74	
490	1LA4400-6AN60-Z + B20	991	95.9	96.0	0.84	59.0	4722	1.05	5.50	2.30	21.2	740	73/76	
570	1LA4402-6AN60-Z + B20	992	96.2	96.3	0.84	68.0	5487	1.10	5.50	2.30	24.2	1193	73/76	
630	1LA4404-6AN60-Z + B20	991	96.3	96.3	0.82	77.0	6071	1.20	5.50	2.40	27.3	1233	73/76	

1) Temperature class F, utilization in accordance with B.

2) Measured at distance of 1 m in accordance with DIN 45635 (Part 1), tolerance +3 dB(A).

# High-Voltage Motors H-compact Standardline

## Operation on supply system

Rated output 1)	Order No. + order codes for further options	Operating values at rated output						Starting torque	Starting current	Stalling torque	Moment of inertia J		Sound pressure level 2)
		Rated speed	Efficiency $\eta$ with		Power factor $\cos \varphi$	Rated current	Rated torque				with direct starting as multiple of rated torque	current	
kW		rpm	%	%		A	Nm				kgm <sup>2</sup>	kgm <sup>2</sup>	dB(A)
<b>6.6 kV, 50 Hz</b>													
<b>3000 rpm, 2-pole</b>													
<b>200</b>	<b>1LA4310-2AN70-Z + B20</b>	2977	95.4	95.2	0.85	21.5	641	1.10	6.00	2.80	2.2	28	73/74
<b>236</b>	<b>1LA4312-2AN70-Z + B20</b>	2975	95.2	95.2	0.84	26.0	757	1.10	5.90	2.80	2.2	26	73/74
<b>300</b>	<b>1LA4314-2AN70-Z + B20</b>	2978	95.9	95.7	0.85	32.5	962	1.30	6.15	2.95	2.7	30	73/74
<b>355</b>	<b>1LA4316-2AN70-Z + B20</b>	2980	96.3	96.1	0.85	38.0	1138	1.35	6.30	3.05	3.1	35	73/74
<b>400</b>	<b>1LA4350-2AN70-Z + B20</b>	2983	96.3	96.2	0.85	43.0	1280	1.30	6.10	2.80	4.3	38	75/76
<b>450</b>	<b>1LA4352-2AN70-Z + B20</b>	2983	96.5	96.3	0.85	48.0	1441	1.45	6.50	3.05	4.8	43	75/76
<b>500</b>	<b>1LA4354-2AN70-Z + B20</b>	2985	96.7	96.7	0.85	53.5	1600	1.45	6.50	3.05	5.2	46	75/76
<b>560</b>	<b>1LA4400-2AN70-Z + B20</b>	2988	96.5	96.3	0.84	60.5	1790	1.00	6.30	3.05	7.8	26	77/78
<b>650</b>	<b>1LA4402-2AN70-Z + B20</b>	2988	96.8	96.6	0.85	69.0	2077	1.10	6.60	3.20	8.7	27	77/78
<b>750</b>	<b>1LA4404-2AN70-Z + B20</b>	2989	97.1	96.8	0.87	78.5	2396	1.15	6.70	3.20	9.9	30	77/78
<b>1500 rpm, 4-pole</b>													
<b>200</b>	<b>1LA4 310-4AN70-Z + B20</b>	1484	94.4	94.2	0.74	25.0	1287	1.40	5.75	2.80	2.8	159	75/77
<b>250</b>	<b>1LA4 312-4AN70-Z + B20</b>	1485	95.2	95.2	0.79	29.0	1609	1.40	6.10	2.80	3.5	201	75/77
<b>300</b>	<b>1LA4 314-4AN70-Z + B20</b>	1484	95.4	95.3	0.80	35.0	1931	1.55	6.30	2.95	4.0	222	75/77
<b>365</b>	<b>1LA4 316-4AN70-Z + B20</b>	1485	95.9	95.9	0.80	42.0	2346	1.55	6.35	2.95	4.8	297	75/77
<b>400</b>	<b>1LA4 350-4AN70-Z + B20</b>	1488	95.8	95.6	0.77	47.5	2567	1.50	6.20	3.05	6.0	224	77/79
<b>470</b>	<b>1LA4 352-4AN70-Z + B20</b>	1488	96.1	96.0	0.80	53.0	3017	1.45	6.15	2.85	6.9	247	77/79
<b>560</b>	<b>1LA4 354-4AN70-Z + B20</b>	1490	96.4	96.3	0.82	62.0	3592	1.55	6.40	2.95	8.1	296	77/79
<b>630</b>	<b>1LA4 400-4AN70-Z + B20</b>	1491	96.4	96.2	0.80	71.5	4036	1.45	6.35	3.05	11.6	288	79/81
<b>710</b>	<b>1LA4 402-4AN70-Z + B20</b>	1491	96.6	96.4	0.81	79.5	4548	1.45	6.40	3.05	12.9	330	79/81
<b>800</b>	<b>1LA4 404-4AN70-Z + B20</b>	1491	96.7	96.5	0.82	88.5	5125	1.45	6.40	3.05	14.5	381	79/81
<b>1000 rpm, 6-pole</b>													
<b>236</b>	<b>1LA4 314-6AN70-Z + B20</b>	989	94.8	94.8	0.77	28.5	2279	1.50	6.10	3.05	5.3	375	69/72
<b>270</b>	<b>1LA4 316-6AN70-Z + B20</b>	988	95.1	95.2	0.78	31.5	2609	1.55	6.45	2.95	6.4	431	69/72
<b>315</b>	<b>1LA4 350-6AN70-Z + B20</b>	991	95.5	95.4	0.78	37.0	3034	1.35	6.15	2.80	10.8	541	71/74
<b>365</b>	<b>1LA4 352-6AN70-Z + B20</b>	991	95.8	95.7	0.79	42.0	3515	1.35	6.20	2.70	12.7	667	71/74
<b>425</b>	<b>1LA4 354-6AN70-Z + B20</b>	992	95.9	95.8	0.78	50.0	4091	1.55	6.40	2.95	15.0	841	71/74
<b>490</b>	<b>1LA4 400-6AN70-Z + B20</b>	993	96.0	95.9	0.81	55.5	4713	1.30	6.45	2.80	21.2	740	73/76
<b>570</b>	<b>1LA4 402-6AN70-Z + B20</b>	994	96.3	96.2	0.81	64.5	5476	1.35	6.45	2.80	24.2	1193	73/76
<b>630</b>	<b>1LA4 404-6AN70-Z + B20</b>	993	96.4	96.2	0.78	73.0	6060	1.45	6.45	2.95	27.3	1233	73/76

1) Temperature class F, utilization in accordance with B.

2) Measured at distance of 1 m in accordance with DIN 45635 (Part 1), tolerance +3 dB(A).

### Ordering example:

High-voltage motor  
H-compact Standardline basic version  
6.6 kV, 50 Hz, 1500 rpm, 4-pole, 300 kW  
with option M13: Anti-condensation heating for 230 V

**1LA4314-4AN70-Z  
+B20+M13**

### Options

Option description	Order code	Comment
Standardline design	<b>B20</b>	Always state
Motor protection through PTC thermistor with 6 built-in temperature sensors for alarm and switch-off	<b>A12</b>	
Motor temperature sensing by means of 6 built-in PT100 G resistance thermometers	<b>A65</b>	Standard
Installation of 2 screw-in PT100 resistance thermometers in basic circuit for rolling-contact bearings	<b>A40</b>	
Nipples for SPM (shock pulse measurement)	<b>G50</b>	Standard
Terminal box on RHS (view onto DE)	<b>K09</b>	
Terminal box on LHS (view onto DE)	<b>K10</b>	
Terminal box at 90° angle, cable from DE	<b>K83</b>	
Terminal box at 90° angle, cable from NDE	<b>K84</b>	
Terminal box at 180° angle, cable from top	<b>K85</b>	
Special finish in standard color RAL 7030	<b>K26</b>	
Anti-condensation heating for 110 V	<b>M12</b>	
Anti-condensation heating for 230 V	<b>M13</b>	
Supplementary (second) auxiliary terminal box in grey cast iron	<b>M50</b>	
Version for clockwise rotation	<b>K97</b>	
Version for counter-clockwise rotation	<b>K98</b>	
Ambient temperature 45 °C	<b>D11</b>	With utilization in accordance with F
Ambient temperature 50 °C	<b>D12</b>	With utilization in accordance with F
Ambient temperature 55 °C	<b>D13</b>	With utilization in accordance with F
<b>Documentation</b>		
Documentation in English	-	Standard
Documentation in German	<b>D00</b>	
Documentation in Russian	<b>D56</b>	
Documentation in Italian	<b>D72</b>	
Documentation in French	<b>D77</b>	
Documentation in Spanish	<b>D78</b>	
Documentation in Portuguese	<b>D79</b>	
Documentation in Swedish	<b>D83</b>	
Documentation on CD-ROM	<b>B21</b>	

# High-Voltage Motors H-compact Standardline

## Operation on supply system

### Dimensional drawings

Design:

Type IM B3, rolling-contact bearing, degree of protection IP55,  
type of cooling IC 441

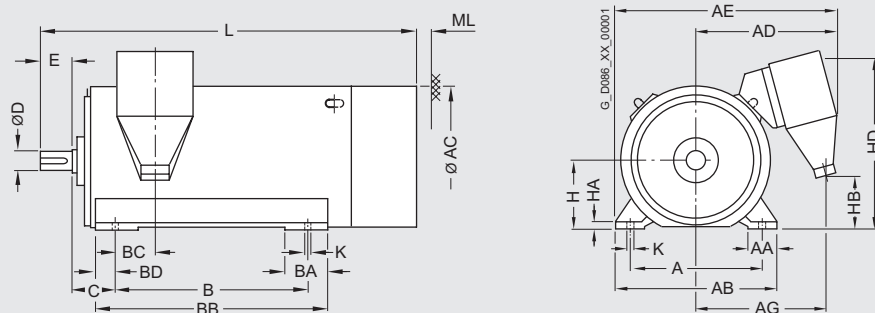

Type	Weight kg	A mm	AD mm	AE mm	B mm	C mm	H mm	HD mm	L mm	D mm	E mm
<b>2-pole</b>											
1LA4310-2	1550	610	710	1075	710	200	315	860	1590	70	105
1LA4312-2	1550	610	710	1075	710	200	315	860	1590	70	105
1LA4314-2	1850	610	710	1075	900	200	315	860	1790	70	105
1LA4316-2	2000	610	710	1075	900	200	315	860	1790	70	105
1LA4350-2	2300	686	740	1155	1000	224	355	930	1930	75	105
1LA4352-2	2400	686	740	1155	1000	224	355	930	1930	75	105
1LA4354-2	2550	686	740	1155	1000	224	355	930	1930	75	105
1LA4400-2	3150	750	775	1120	1120	254	400	1010	2095	85	130
1LA4402-2	3300	750	775	1120	1120	254	400	1010	2095	85	130
1LA4404-2	3550	750	775	1120	1120	254	400	1010	2095	85	130
<b>4-pole</b>											
1LA4310-4	1500	610	710	1075	710	200	315	860	1610	90	130
1LA4312-4	1650	610	710	1075	710	200	315	860	1610	90	130
1LA4314-4	1900	610	710	1075	900	200	315	860	1810	90	130
1LA4316-4	2050	610	710	1075	900	200	315	860	1810	90	130
1LA4350-4	2350	686	740	1155	1000	224	355	930	1985	100	165
1LA4352-4	2550	686	740	1155	1000	224	355	930	1985	100	165
1LA4354-4	2750	686	740	1155	1000	224	355	930	1985	100	165
1LA4400-4	3400	750	775	1125	1120	254	400	1010	2125	120	165
1LA4402-4	3600	750	775	1125	1120	254	400	1010	2125	120	165
1LA4404-4	3800	750	775	1125	1120	254	400	1010	2125	120	165
<b>6-pole</b>											
1LA4314-6	1950	610	710	1075	900	200	315	860	1810	90	130
1LA4316-6	2150	610	710	1075	900	200	315	860	1810	90	130
1LA4350-6	2400	686	740	1155	1000	224	355	930	1985	100	165
1LA4352-6	2600	686	740	1155	1000	224	355	930	1985	100	165
1LA4354-6	2850	686	740	1155	1000	224	355	930	1985	100	165
1LA4400-6	3500	750	775	1225	1120	254	400	1010	2125	120	165
1LA4402-6	3750	750	775	1225	1120	254	400	1010	2125	120	165
1LA4404-6	4000	750	775	1225	1120	254	400	1010	2125	120	165

### More information

#### Description - construction details

##### Housing, cooling system

The stator housing on all motors is made of grey cast iron.

The housing contains 4 axial cooling air ducts equally spaced around the circumference.

The main and auxiliary terminal boxes are bolted onto the two upper ducts, which also contain the winding conductors and monitoring cables.

The two bottom ducts are located in the foot area.

These cooling air ducts are a component of the supplementary inner cooling circuit that is a feature of Siemens H-compact and N-compact motors. This cooling circuit ensures even thermal distribution within the motor and provides for optimum cooling. The resulting bearing and winding overhang temperatures have a positive impact on the service life and availability of the motors.

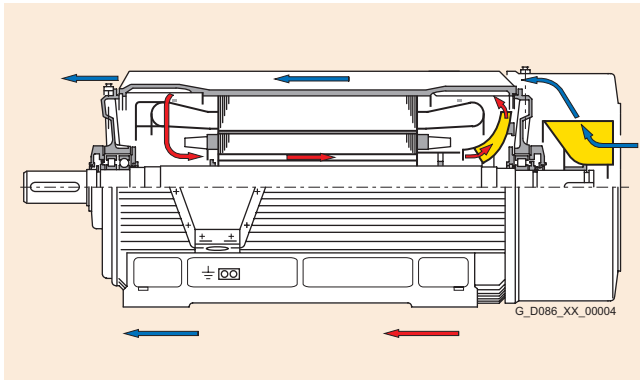

##### Hoisting gear

Two diagonally arranged, reversible hoisting lugs which align automatically with the lifting cable, i.e. according to the applied direction of force.

##### Rotor construction

The rotor winding is made of die-cast aluminum.

The aluminum is poured into the rotor slots under pressure and thus bonded with the rotor laminations in a positive connection. This method of manufacture precludes any risk of cage movement or cage "creepage" in the rotor core.

Another advantage of the die-cast method is the excellent thermal coupling between the cage and laminated rotor core, resulting in high permissible starting and rotor locking times.

##### Shaft

All motors have a shaft extension designed according to DIN 748 "short" with key steel featherkey according to DIN 6880. The rotors are balanced with half-key.

##### Direction of rotation, fans and fan shroud

**The direction of rotation must be stated in every order!**

On 2-pole motors, the external fan is a low-noise, direction-dependent axial fan. 4-pole and 6-pole motors are equipped with a direction-neutral radial fan.

The external fan is covered by a sheet-steel shroud.

##### Vibration response

H-compact Standardline motors comply with vibration severity grade N as stipulated by IEC 60034-14, or grade A according to the revised version of IEC 60034-14 (valid from December 2006). The vibration levels remain well below limit values in most cases.

##### Insulation system

The SIEMENS-MICALASTIC® insulation system, tried and tested on high-power high-voltage motors for many years, has been used on the H-compact Standardline range.

The MICALASTIC insulation system complies with temperature class F, thermally utilized according to B (in normal operation).

An important element is the VPI (Vacuum Pressure Impregnation) process which is specially tailored to this insulation system.

The winding is resistant to system transfers with 100% residual field and switching operations up to 110% with phase opposition.

The surge withstand capability of the insulation satisfies insulation coordination requirements. The insulation properties exceed the values ( $V_p = 4 \times V_{rated} + 5 \text{ kV}$ ) stipulated in DIN EN 60034-15/VDE 0530-15.

##### Noise

H-compact Standardline motors are low-noise machines. This is achieved by:

- Motor construction designed for low noise
- Optimization of external ventilation
- Fans with good air-flow form design
- Noise-optimized construction of steel fan shroud
- Number of stator and rotor slots carefully selected for low magnetic noise excitation

##### Switching frequency

H-compact Standardline motors are designed for continuous operation in accordance with IEC / VDE 0530 Part 1. The permissible switching frequency limit is 5000 starts per year.

## Operation on supply system

### Terminal box 1XA8711

Rated voltage 6.6 kV, up to 315 A, 3 terminals (M16) for mains connection

- Up to 240 mm<sup>2</sup> conductor cross section with cable lug in accordance with DIN 46234,
- Up to 400 mm<sup>2</sup> conductor cross section with cable lug in accordance with DIN 46235,
- Alternatively, connection without cable lug,

Internal ground connection

Mounted on motor on RHS at DE (looking towards the DE shaft end).

As an option, the terminal box can be mounted on LHS at DE, rotated through an angle of 90° or 180°.

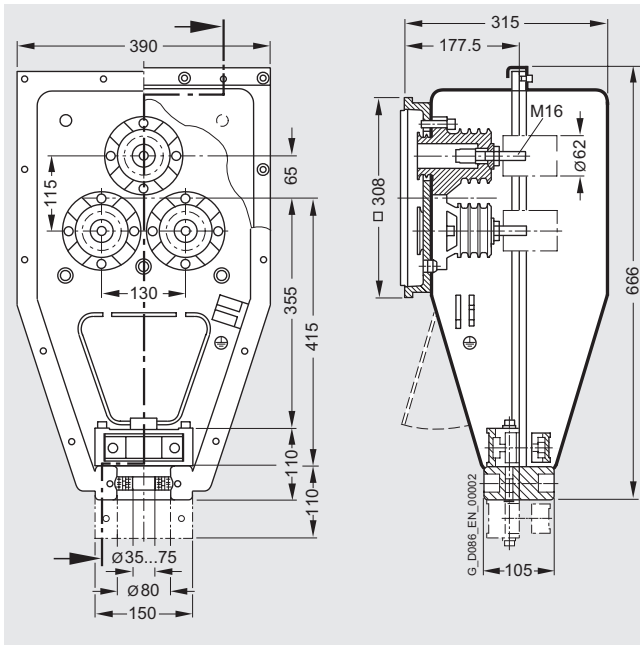

### Auxiliary terminal box 1XB9014

The auxiliary terminal box is designed to hold terminals for connecting monitoring elements, heating, etc. It is made of aluminum and is shipped as standard with a cable entry plate without drill holes. This means that the cable entry parameters do not need to be clarified in advance when the motor is ordered. The plate is secured by 2 or 4 screws and can be removed easily for machining with the required entry holes.

- Dimensions (W x D x H): 360 x 160 x 90 mm
- No. of terminals: 35
- Max. box mounting height: 50 mm

### Paint finish

Two paint systems - standard paint and special paint - are available for protecting motors against corrosion. They satisfy the following requirements relating to environmental conditions:

The **Standard paint** is categorized in the "Moderate" climate group as specified by IEC 721-2-1.

It is suitable for

- installation indoors or outdoors under cover, without direct natural weathering.
- Temperatures up to +120 °C for short periods or +100 °C continuously.
- Rel. air humidity up to 100% at temperatures up to +30 °C for short periods, up to 85% at temperatures up to +25 °C continuously.

Normal paint system:

- Primer approx. 30 µm on parts which can be dipped (casting), approx. 60 µm on parts which can be sprayed (steel)
- Final coat approx. 30 µm

The **Special paint** is categorized in the "Worldwide" climate group as specified by IEC 721-2-1.

It is suitable for

- installation outdoors with direct exposure to solar radiation and weathering over a wide temperature and humidity range (industrial or coastal areas are typical installation sites).
- Temperatures up to +140 °C for short periods or +120 °C continuously.

Special paint system:

- Primer approx. 30 µm on parts which can be dipped (casting), approx. 60 µm on parts which can be sprayed (steel)
- Final coat approx. 60 µm

The primer coat is applied to internal and external surfaces, the final coat to external surfaces.

Increased total film thicknesses, e.g. 120 or 150 µm, are available at an additional cost.

### Bearing construction

The motors are equipped with deep-groove ball bearings in accordance with DIN 625.

The location bearing is positioned at the DE.

All rolling-contact bearings are lubricated with mineral-oil-based lithium soap grease. The bearings have a re-greasing device with flat grease nipple M10 x 1 to DIN 3404 and a collector for used grease which is large enough to cover the calculated bearing life when the re-greasing intervals and quantities are observed (lubrication data can be found on lubrication plate or in order documentation).

The rolling-contact bearings are sealed externally by V-ring seals and internally by gap seals.

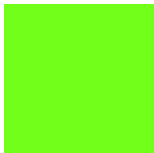

<b>5/2</b>	<b>Siemens contacts worldwide</b>
<b>5/3</b>	<b>A&amp;D Online Services</b>
5/3	Information and Ordering in the Internet and on CD-ROM
<b>5/4</b>	<b>Customer Support</b>
5/4	Our Services for Every Phase of Your Project
5/5	Knowledge Base and Automation Value Card
<b>5/8</b>	<b>Conditions of sale and delivery, Export regulations</b>



# Appendix

## Siemens contacts worldwide



At

<http://www.siemens.com/automation/partner>

you can find details of Siemens contact partners worldwide responsible for particular technologies.

You can obtain in most cases a contact partner for

- Technical Support,
- Spare parts/repairs,
- Service,
- Training,
- Sales or
- Consultation/engineering.

You start by selecting a

- Country,
- Product or
- Sector.

By further specifying the remaining criteria you will find exactly the right contact partner with his/her respective expertise.

### A&D in the WWW



A detailed knowledge of the range of products and services available is essential when planning and configuring automation systems. It goes without saying that this information must always be fully up-to-date.

The Siemens Automation and Drives Group (A&D) has therefore built up a comprehensive range of information in the World Wide Web, which offers quick and easy access to all data required.

Under the address

<http://www.siemens.com/automation>

you will find everything you need to know about products, systems and services.

### Product Selection Using the Interactive Catalog

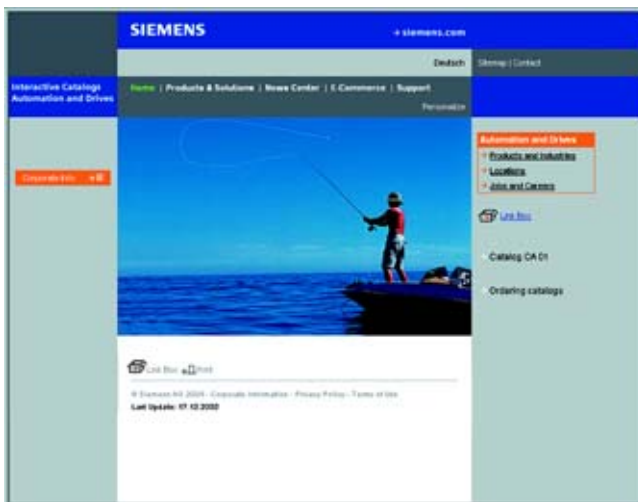

Detailed information together with convenient interactive functions:

The interactive catalog CA 01 covers more than 80,000 products and thus provides a full summary of the Siemens Automation and Drives product base.

Here you will find everything that you need to solve tasks in the fields of automation, switchgear, installation and drives. All information is linked into a user interface which is easy to work with and intuitive.

After selecting the product of your choice you can order at the press of a button, by fax or by online link.

Information on the interactive catalog can be found in the Internet under

<http://www.siemens.com/automation/ca01>

or on CD-ROM.

### Easy Shopping with the A&D Mall



The A&D Mall is the virtual department store of Siemens AG in the Internet. Here you have access to a huge range of products presented in electronic catalogs in an informative and attractive way.

Data transfer via EDIFACT allows the whole procedure from selection through ordering to tracking of the order to be carried out online via the Internet.

Numerous functions are available to support you.

For example, powerful search functions make it easy to find the required products, which can be immediately checked for availability. Customer-specific discounts and preparation of quotes can be carried out online as well as order tracking and tracing.

Please visit the A&D Mall on the Internet under:

<http://www.siemens.com/automation/mall>

# Appendix Customer Support

## Our Services for Every Phase of Your Project



In the face of harsh competition you need optimum conditions to keep ahead all the time:

A strong starting position. A sophisticated strategy and team for the necessary support - in every phase.

Service & Support from Siemens provides this support with a complete range of different services for automation and drives.

In every phase: from planning and startup to maintenance and upgrading.

Our specialists know when and where to act to keep the productivity and cost-effectiveness of your system running in top form.

### Configuration and Software Engineering



Support in configuring and developing with customer-oriented services from actual configuration to implementation of the automation project. <sup>1)</sup>

### Service On Site



With Service On Site we offer services for startup and maintenance, essential for ensuring system availability.

In Germany  
**0180 50 50 444 <sup>1)</sup>**

### Online Support



The comprehensive information system available round the clock via Internet ranging from Product Support and Service & Support services to Support Tools in the Shop.

<http://www.siemens.com/automation/service&support>

### Repairs and Spare Parts



In the operating phase of a machine or automation system we provide a comprehensive repair and spare parts service ensuring the highest degree of operating safety and reliability.

In Germany  
**0180 50 50 446 <sup>1)</sup>**

### Technical Support



Competent consulting in technical questions covering a wide range of customer-oriented services for all our products and systems.

**Tel.: +49 (0)180 50 50 222**  
**Fax: +49 (0)180 50 50 223**  
<http://www.siemens.com/automation/support-request>

### Optimization and Upgrading



To enhance productivity and save costs in your project we offer high-quality services in optimization and upgrading. <sup>1)</sup>

### Technical Consulting



Support in the planning and designing of your project from detailed actual-state analysis, target definition and consulting on product and system questions right to the creation of the automation solution. <sup>1)</sup>

<sup>1)</sup> For country-specific telephone numbers go to our Internet site at: <http://www.siemens.com/automation/service&support>

## Knowledge Base on CD-ROM



For locations without online connections to the Internet there are excerpts of the free part of the information sources available on CD-ROM (Service & Support Knowledge Base). This CD-ROM contains all the latest product information at the time of production (FAQs, Downloads, Tips and Tricks, Updates) as well as general information on Service and Technical Support.

The CD-ROM also includes a full-text search and our Knowl-

edge Manager for targeted searches for solutions. The CD-ROM will be updated every 4 months.

Just the same as our online offer in the Internet, the Service & Support Knowledge Base on CD comes complete in 5 languages (German, English, French, Italian, Spanish).

You can order the **Service & Support Knowledge Base** CD from your Siemens contact.

Order no. **6ZB5310-0EP30-0BA2**

Orders via the Internet (with Automation Value Card or credit card) at:

<http://www.siemens.com/automation/service&support>

in the Shop domain.

## Automation Value Card



### Small card - great support

The Automation Value Card is an integral component of the comprehensive service concept with which Siemens Automation and Drives will accompany you in each phase of your automation project.

It doesn't matter whether you want just specific services from our Technical Support or want to purchase high-quality Support Tools in our Online Shop, you can always pay with your Automation Value Card. No invoicing, transparent and safe. With your personal card number and associated PIN you can view the state of your account and all transactions at any time.

Services on card. This is how it's done.

Card number and PIN are on the back of the Automation Value Card. When delivered, the PIN is covered by a scratch field, guaranteeing that the full credit is on the card.

By entering the card number and PIN you have full access to the Service & Support services being offered. The charge for the services procured is debited from the credits on your Automation Value Card.

All the services offered are marked in currency-neutral credits, so you can use the Automation Value Card worldwide.

### Automation Value Card order numbers

Credits	Order no.
200	<b>6ES7 997-0BA00-0XA0</b>
500	<b>6ES7 997-0BB00-0XA0</b>
1000	<b>6ES7 997-0BC00-0XA0</b>
10000	<b>6ES7 997-0BG00-0XA0</b>

Detailed information on the services offered is available on our Internet site at:

<http://www.siemens.com/automation/service&support>

### Service & Support à la Card: Examples

#### Technical Support

"Priority"	Priority processing for urgent cases
"24 h"	Availability round the clock
"Extended"	Technical consulting for complex questions

#### Support Tools in the Support Shop

"System Utilities"	Tools that can be used directly for configuration, analysis and testing
"Applications"	Complete topic solutions including ready-tested software
"Functions & Samples"	Adaptable blocks for accelerating your developments

# Appendix

Notes

5





## Conditions of sale and delivery

### Terms and Conditions of Sale and Delivery

By using this catalog you can acquire hardware and software products described therein from the Siemens AG subject to the following terms. Please note! The scope, the quality and the conditions for supplies and services, including software products, by any Siemens entity having a registered office outside of Germany, shall be subject exclusively to the General Terms and Conditions of the respective Siemens entity.

#### **For customers with a seat or registered office in the Federal Republic of Germany**

The "General Terms of Payment" as well as the "General Conditions for the Supply of Products and Services of the Electrical and Electronics Industry" shall apply.

For software products, the "General License Conditions for Software Products for Automation and Drives for Customers with a Seat or registered Office in Germany" shall apply.

#### **For customers with a seat or registered office outside of Germany**

The "General Terms of Payment" as well as the "General Conditions for Supplies of Siemens. Automation and Drives for Customers with a Seat or registered Office outside of Germany" shall apply.

For software products, the "General License Conditions for Software Products for Automation and Drives for Customers with a Seat or registered Office outside of Germany" shall apply.

#### **General**

The prices are in € (Euro) ex works, exclusive packaging.

The sales tax (value added tax) is not included in the prices. It shall be debited separately at the respective rate according to the applicable legal regulations.

In addition to the prices of products which include silver, plump, aluminum and/or copper, surcharges may be calculated if the respective limits of the notes are exceeded. The respective note (e.g. source: German newspaper "Handesblatt" in category "deutsche Edelmetalle" and "Metallverarbeiter") for silver ("verarbeitetes Silber"), plump ("Blei in Kabeln"), aluminum ("Aluminium in Kabeln") and copper ("Elektrolytkupfer", "DEL-Notiz") respectively, of the day the order or rather the on call order is received, is decisive for the calculation of the surcharges.

Surcharges of copper shall be calculated for Drives at a note ("DEL-Notiz") above EUR 225,00 / 100 Kg and for chokes / transformers above EUR 150,00 / 100 kg.

Surcharges shall be charged based on the quantities of the materials which are contained in the relevant products.

Prices are subject to change without prior notice. We will debit the prices valid at the time of delivery.

The dimensions are in mm. Illustrations are not binding.

Insofar as there are no remarks on the corresponding pages, - especially with regard to data, dimensions and weights given - these are subject to change without prior notice.

Comprehensive Terms and Conditions of Sale and Delivery are available free of charge from your local Siemens business office under the following Order Nos.:

- 6ZB5310-0KR30-0BA0  
(for customers based in the Federal Republic of Germany)
- 6ZB5310-0KS53-0BA0  
(for customers based outside of the Federal Republic of Germany)

or download them from the Internet:

<http://www.siemens.com/automation/mall>

(Germany: A&D Mall Online-Help System)

### Export regulations

The products listed in this catalog may be subject to European / German and/or US export regulations.

Therefore, any export requiring a license is subject to approval by the competent authorities.

According to current provisions, the following export regulations must be observed with respect to the products featured in this catalog:

AL	Number of the <u>German Export List</u> . Products marked other than "N" require an export license. In the case of software products, the export designations of the relevant data medium must also be generally adhered to. Goods labeled with an " <u>AL not equal to N</u> " are subject to a European or German export authorization when being exported out of the EU.
ECCN	<u>Export Control Classification Number</u> . Products marked other than "N" are subject to a reexport license to specific countries. In the case of software products, the export designations of the relevant data medium must also be generally adhered to. Goods labeled with an " <u>ECCN not equal to N</u> " are subject to a US re-export authorization.

Even without a label or with an "AL: N" or "ECCN: N", authorization may be required due to the final destination and purpose for which the goods are to be used.

The deciding factors are the AL or ECCN export authorization indicated on order confirmations, delivery notes and invoices.

Errors excepted and subject to change without prior notice.

A&D/VuL/En 17.03.05

Responsible for

Technical content:  
Siemens AG, A&D LD M MS

General editing:  
Siemens AG, A&D PT 5, Erlangen

Siemens AG  
Automation and Drives  
[Large Drives](#)

Postfach 47 43  
90025 NÜRNBERG  
GERMANY

Order No.  
**E86060-K5586-A111-A1-7600**  
KG 0705 6.0 E 40 En/ 522445  
Printed in Germany



Further information can be obtained from our branch offices listed in the appendix or at [www.siemens.com/automation/partner](http://www.siemens.com/automation/partner)

<b>Automation and Drives</b>	<i>Catalog</i>	
Interactive catalog on CD-ROM		
• The Offline Mall of Automation and Drives	CA 01	
<b>Automation Systems for Machine Tools</b>		
SINUMERIK & SIMODRIVE	NC 60	
<b>Drive Systems</b>		
<u>Variable-Speed Drives</u>		
SINAMICS G130 Drive Converter Chassis Units,	D 11	
SINAMICS G150 Drive Converter Cabinet Units		
SINAMICS G110 Inverter Chassis Units	D 11.1	
SINAMICS S120 Servo Control Drive System	D 21.2	
SINAMICS S150 Drive Converter Cabinet Units	D 21.3	
DC Motors	DA 12	
SIMOREG DC MASTER 6RA70 Digital Chassis Converters	DA 21.1	
SIMOREG K 6RA22 Analog Chassis Converters	DA 21.2	
SIMOREG DC MASTER 6RM70 Digital Converter Cabinet Units	DA 22	
SIMOVERT PM Modular Converter Systems	DA 45	
SIEMOSYN Motors	DA 48	
MICROMASTER 410/420/430/440 Inverters	DA 51.2	
MICROMASTER 411/COMBIMASTER 411	DA 51.3	
SIMOVERT MV Medium-Voltage Drives	DA 63	
SIMOVERT MASTERDRIVES Vector Control	DA 65.10	
SIMOVERT MASTERDRIVES Motion Control	DA 65.11	
Synchronous and asynchronous servomotors for SIMOVERT MASTERDRIVES	DA 65.3	
SIMODRIVE 611 universal and POSMO	DA 65.4	
<u>Low-Voltage Three-Phase-Motors</u>		
Squirrel-Cage Motors, Totally Enclosed, Fan-Cooled	M 11	
<u>Automation Systems for Machine Tools SIMODRIVE</u>	NC 60	
• Main Spindle Motors		
• Feed Motors		
• Converter Systems SIMODRIVE 611/POSMO		
<u>Drive and Control Components for Hoisting Equipment</u>	HE 1	
<b>Electrical Installation Technology</b>		
ALPHA Small Distribution Boards and Distribution Boards	ET A1	
<i>PDF: ALPHA 8HP Molded-Plastic Distribution System</i>	ET A3	
ALPHA FIX Terminal Blocks	ET A5	
BETA Modular Installation Devices	ET B1	
DELTA Switches and Outlets	ET D1	
GAMMA Building Management Systems	ET G1	
<b>Factory Automation Sensors</b>	FS 10	
<b>Human Machine Interface Systems SIMATIC HMI</b>	ST 80	
<b>Industrial Communication for Automation and Drives</b>	IK PI	
<b>Low-Voltage Controls and Distribution</b>	<i>Catalog</i>	
Low-Voltage Switchgear – Controlgear for Industry	LV 10	
Power Distribution – Products and Systems for Low-Voltage Power Distribution	LV 30	
SIDAC reactors and filters	LV 60	
SIVACON 8PS Busbar trunking systems CD, BD01, BD2 up to 1250 A	LV 70	
Low-Voltage Controlgear, Switchgear and Systems	LV 90	
<b>Motion Control System SIMOTION</b>	PM 10	
<b>Process Instrumentation and Analytics</b>		
Field Instruments for Process Automation	FI 01	
Measuring Instruments for Pressure, Differential Pressure, Flow, Level and Temperature, Positioners and Liquid Meters		
<i>PDF: Indicators for panel mounting</i>	MP 12	
SIREC Recorders and Accessories	MP 20	
SIPART, Controllers and Software	MP 31	
SIWAREX Weighing Systems	WT 01	
Continuous Weighing and Process Protection	WT 02	
Gas Analysis Equipment for the Process Industry	PA 10	
<i>PDF: Process Analytics, Components for the System Integration</i>	PA 11	
SIPAN Liquid Analysis	PA 20	
<b>SIMATIC Industrial Automation Systems</b>		
SIMATIC PCS Process Control System	ST 45	
<i>PDF: SIMATIC S5/505 Automation Systems</i>	ST 50	
Products for Totally Integrated Automation and Micro Automation	ST 70	
SIMATIC PCS 7 Process Control System	ST PCS 7	
<i>PDF: Add-ons for the SIMATIC PCS 7 Process Control System</i>	ST PCS 7.A	
pc-based Automation	ST PC	
SIMATIC Control Systems	ST DA	
<b>SIPOS Electric Actuators</b>		
Electric Rotary, Linear and Part-turn Actuators	MP 35	
Electric Rotary Actuators for Nuclear Plants	MP 35.1/.2	
<b>Systems Engineering</b>		
Power supplies SITOP power	KT 10.1	
System cabling SIMATIC TOP connect	KT 10.2	
<b>System Solutions</b>		
Applications and Products for Industry are part of the interactive catalog CA 01		
<b>TELEPERM M Process Control System</b>		
<i>PDF: AS 488/TM automation systems</i>	PLT 112	



The information provided in this catalog contains descriptions or characteristics of performance which in case of actual use do not always apply as described or which may change as a result of further development of the products. An obligation to provide the respective characteristics shall only exist if expressly agreed in the terms of contract. Availability and technical specifications are subject to change without notice.

**Siemens AG**

Automation and Drives

Large Drives

Postfach 47 43, D-90025 Nürnberg

[www.siemens.com/motors](http://www.siemens.com/motors)

Order No. E86060-K5586-A111-A1-7600